

---

# PeopleSoft HCM 9.2: PeopleSoft Talent Acquisition Manager

---

**September 2024**

This software and related documentation are provided under a license agreement containing restrictions on use and disclosure and are protected by intellectual property laws. Except as expressly permitted in your license agreement or allowed by law, you may not use, copy, reproduce, translate, broadcast, modify, license, transmit, distribute, exhibit, perform, publish, or display any part, in any form, or by any means. Reverse engineering, disassembly, or decompilation of this software, unless required by law for interoperability, is prohibited.

The information contained herein is subject to change without notice and is not warranted to be error-free. If you find any errors, please report them to us in writing.

If this is software, software documentation, data (as defined in the Federal Acquisition Regulation), or related documentation that is delivered to the U.S. Government or anyone licensing it on behalf of the U.S. Government, then the following notice is applicable:

U.S. GOVERNMENT END USERS: Oracle programs (including any operating system, integrated software, any programs embedded, installed, or activated on delivered hardware, and modifications of such programs) and Oracle computer documentation or other Oracle data delivered to or accessed by U.S. Government end users are "commercial computer software," "commercial computer software documentation," or "limited rights data" pursuant to the applicable Federal Acquisition Regulation and agency-specific supplemental regulations. As such, the use, reproduction, duplication, release, display, disclosure, modification, preparation of derivative works, and/or adaptation of i) Oracle programs (including any operating system, integrated software, any programs embedded, installed, or activated on delivered hardware, and modifications of such programs), ii) Oracle computer documentation and/or iii) other Oracle data, is subject to the rights and limitations specified in the license contained in the applicable contract. The terms governing the U.S. Government's use of Oracle cloud services are defined by the applicable contract for such services. No other rights are granted to the U.S. Government.

This software or hardware is developed for general use in a variety of information management applications. It is not developed or intended for use in any inherently dangerous applications, including applications that may create a risk of personal injury. If you use this software or hardware in dangerous applications, then you shall be responsible to take all appropriate fail-safe, backup, redundancy, and other measures to ensure its safe use. Oracle Corporation and its affiliates disclaim any liability for any damages caused by use of this software or hardware in dangerous applications.

Oracle®, Java, MySQL, and NetSuite are registered trademarks of Oracle and/or its affiliates. Other names may be trademarks of their respective owners.

Intel and Intel Inside are trademarks or registered trademarks of Intel Corporation. All SPARC trademarks are used under license and are trademarks or registered trademarks of SPARC International, Inc. AMD, Epyc, and the AMD logo are trademarks or registered trademarks of Advanced Micro Devices. UNIX is a registered trademark of The Open Group.

This software or hardware and documentation may provide access to or information about content, products, and services from third parties. Oracle Corporation and its affiliates are not responsible for and expressly disclaim all warranties of any kind with respect to third-party content, products, and services unless otherwise set forth in an applicable agreement between you and Oracle. Oracle Corporation and its affiliates will not be responsible for any loss, costs, or damages incurred due to your access to or use of third-party content, products, or services, except as set forth in an applicable agreement between you and Oracle.

## **Documentation Accessibility**

For information about Oracle's commitment to accessibility, visit the Oracle Accessibility Program website at <https://docs.oracle.com/pls/topic/lookup?ctx=acc&id=docacc>.

## **Access to Oracle Support**

Oracle customers that have purchased support have access to electronic support through My Oracle Support. For information, visit <https://docs.oracle.com/pls/topic/lookup?ctx=acc&id=info> or visit <https://docs.oracle.com/pls/topic/lookup?ctx=acc&id=trs> if you are hearing impaired.

# Contents

- Preface: Preface..... xxiii**
  - Understanding the PeopleSoft Online Help and PeopleBooks..... xxiii
  - Hosted PeopleSoft Online Help.....xxiii
  - Locally Installed PeopleSoft Online Help.....xxiii
  - Downloadable PeopleBook PDF Files..... xxiii
  - Common Help Documentation..... xxiii
  - Field and Control Definitions..... xxiv
  - Typographical Conventions.....xxiv
  - ISO Country and Currency Codes..... xxv
  - Region and Industry Identifiers.....xxv
  - Translations and Embedded Help..... xxvi
  - Using and Managing the PeopleSoft Online Help.....xxvi
  - PeopleSoft HCM Related Links..... xxvi
  - Contact Us.....xxvi
  - Follow Us.....xxvii
- Chapter 1: Getting Started with Talent Acquisition Manager..... 29**
  - Talent Acquisition Manager Overview.....29
  - Talent Acquisition Manager Integrations..... 31
  - Talent Acquisition Manager Implementation..... 32
- Chapter 2: Defining System-Wide Settings for Recruiting..... 35**
  - Understanding Foundation Data for Recruiting..... 35
    - The HCM Installation Table..... 35
    - HCM Foundation Tables..... 35
    - Human Resources Profile Data..... 36
    - PeopleSoft HCM Common Frameworks..... 36
    - Optional Human Resource Definitions..... 36
  - Setting Up Recruiting Installation Settings..... 37
    - Pages Used to Set Up Talent Acquisition Manager Implementation Defaults..... 38
    - Recruiting Installation - General Page..... 38
    - Recruiting Installation – Jobs Page..... 44
    - Recruiting Installation – Manage Jobs Page..... 48
    - Recruiting Installation – Applicants Page..... 50
    - Online Job Offers – Select Regulatory Regions Page..... 61
    - Recruiting Installation – Last Assigned IDs Page..... 62
- Chapter 3: Setting Up Profile Integration..... 67**
  - Understanding Profile Architecture..... 67
  - Choosing the Primary Person Profile Type for Recruiting..... 68
    - Page Used to Set Up the Primary Person Profile for Recruiting..... 68
    - Understanding the Primary Person Profile Types..... 68
    - Assign Profile Type Defaults Page..... 69
  - Configuring Profiles for Recruiting..... 70
    - Page Used to Configure Profiles for Recruiting Use..... 70
    - Understanding Content Type Configuration for Recruiting..... 70
    - Content Section Configuration – <Content Type> Page..... 70
  - Setting Up Profile Integration for Job Openings..... 74
    - Pages Used to Set Up Profile Integration for Job Openings..... 75

Understanding Setup for Profile Integration for Job Openings.....	75
<b>Chapter 4: Setting Up Recruiting Statuses.....</b>	<b>77</b>
Understanding Recruiting Statuses.....	77
Recruiting Status Areas.....	77
Recruiting Status Setup.....	79
Understanding the Delivered Status Configuration.....	82
Delivered Dispositions By Phase.....	82
Delivered Status Codes for Other Status Areas.....	83
Delivered Status Change Effects.....	85
Non-Configurable Status Processing.....	95
Setting Up Recruiting Statuses.....	98
Pages Used to Set Up Recruiting Statuses.....	98
Recruiting Status and Reason Page.....	98
Recruiting Status Area Page.....	102
Status Successors Page.....	105
Effects of Status Change Page.....	107
<b>Chapter 5: Setting Up Screening Processes.....</b>	<b>111</b>
Understanding Screening Setup.....	111
Screening Criteria.....	111
Processing Rules.....	114
Setting Up the Skills and Employment Questions.....	115
Pages Used to Set Up Questionnaires.....	115
Understanding Skills and Employment Question Setup.....	116
Recruiting Answer Definition Page.....	118
Recruiting Question Definition Page.....	119
Recruiting Question Set Page.....	125
Question Answers Page.....	128
Making Content Types Available for Screening.....	131
Page Used to Configure Content Types for Screening.....	131
Recruiting Content Sections - <Content Type> Page.....	131
Setting Up Screening Level Definitions.....	133
Page Used to Set Up Screening Level Definitions.....	133
Understanding Screening Levels.....	134
Understanding Prescreening and Online Screening.....	136
Screening Definition Page.....	138
(USF) Setting Up Preference Programs.....	143
Pages Used to Set Up U.S. Federal Screening Processes.....	143
Understanding Priority Placement Processing.....	143
Understanding Veterans Preference Codes.....	144
(USF) Priority Placement Page.....	145
(USF) Setup Veterans Preference Page.....	147
<b>Chapter 6: Setting Up Recruiting Roles and Security.....</b>	<b>149</b>
Understanding Recruiting Security.....	149
Recruiting Privileges Granted Through Recruiting Role Types.....	149
Job Opening Security.....	151
Applicant Security.....	151
Understanding Enhanced Applicant Security.....	152
Principals of Enhanced Applicant Security.....	152
Pages Impacted by Enhanced Applicant Security.....	153
Assigning PeopleTools Roles to Recruiting Role Types.....	163
Page Used to Assign PeopleTools Roles to Recruiting Role Types.....	163

Recruiting Roles Page.....	163
<b>Chapter 7: Setting Up Additional Recruiting Definitions.....</b>	<b>167</b>
Setting Up Recruiting Locations.....	167
Page Used to Set Up Recruiting Locations.....	167
Understanding Recruiting Locations.....	167
Recruiting Locations Page.....	168
Setting Up the Job Posting Description Library.....	169
Pages Used to Set Up the Job Posting Description Library.....	169
Understanding the Job Posting Description Library.....	169
Posting Description Type Page.....	170
Posting Description Library Page.....	170
Setting Up Application Attachments.....	171
Page Used to Set Up Application Attachment Types.....	172
Understanding URL Definitions for Application Attachments.....	172
Understanding Attachment Types.....	172
Attachment Type Setup Page.....	174
Setting Up Contact Methods.....	177
Page Used to Set Up Contact Methods.....	177
Contact Methods Page.....	177
Setting Up Interview Definitions.....	178
Pages Used to Set Up Interview Definitions.....	178
Understanding Interview Definitions.....	178
Interview Types Page.....	179
Interview Evaluation Category Page.....	179
Interview Evaluation Ratings Page.....	180
Setting Up Job Offer Components.....	181
Pages Used to Set Up Job Offers.....	181
Understanding Job Offer Setup.....	181
Job Offer Component Type Page.....	182
Job Offer Component Page.....	183
Setting Up Online Job Offer Attachments.....	184
Pages Used to Set Up Online Job Offer Attachments.....	184
Understanding Online Job Offer Attachments.....	185
Job Offer Attachment Setup Page.....	187
Setting Up the Data Transfer to HR.....	188
Page Used to Set Up the Data Transfer to HR.....	188
Manage Hire Setup Page.....	189
<b>Chapter 8: Setting Up Flexible Processes.....</b>	<b>193</b>
Understanding Flexible Processes.....	193
Setting Up Flexible Job Creation Processes.....	195
Pages Used to Set Up Job Creation Processes.....	195
Understanding the Job Creation Process.....	195
Job Creation Process Page.....	197
Configure Field Visibility Page.....	199
Setting Up Flexible Recruiting Processes.....	203
Pages Used to Set Up Recruiting Processes.....	203
Understanding Flexible Recruiting Processes.....	203
Prerequisites.....	208
Recruiting Process Page.....	208
Dispositions and Roles Page.....	212
Actions and Roles Page.....	214

Setting Up Flexible Process Templates and Template Groups.....	216
Pages Used to Set Up Flexible Process Templates and Template Groups.....	217
Understanding Flexible Process Templates and Template Groups.....	217
Flexible Process Template Page.....	218
Flexible Template Group Page.....	220
<b>Chapter 9: Setting Up Recruiting Templates.....</b>	<b>223</b>
Understanding Recruiting Templates.....	223
Setting Up Resume Templates.....	225
Pages Used to Set Up Resume Templates.....	225
Understanding Resume Templates.....	226
Prerequisites.....	233
Template Definition Page.....	233
Template Sections Page.....	234
(NIR) Country Specific Page.....	245
Pre Screening Page.....	245
Answers to Screening Questions Page.....	250
Default Questions Page.....	250
Setting Up Job Opening Templates.....	252
Pages Used to Set Up Job Opening Templates.....	252
Understanding Job Opening Templates.....	252
Prerequisites.....	256
Job Opening Template Page.....	256
Template Structure Page.....	257
Setting Up Job Opening Posting Templates.....	260
Page Used to Set Up Job Opening Posting Templates.....	260
Understanding Job Opening Posting Templates.....	261
Prerequisites.....	261
Posting Template Page.....	261
Setting Up Screening Templates.....	263
Page Used To Set Up Screening Templates.....	263
Understanding Screening Templates.....	263
Prerequisite.....	264
Screening Template Page.....	264
Setting Up Interview Evaluation Templates.....	268
Pages Used to Set Up Interview Evaluation Templates.....	268
Understanding Interview Evaluation Templates.....	268
Prerequisites.....	269
Interview Evaluation Template Page.....	269
Recommendation Reasons Page.....	272
Setting Up Recruitment Templates.....	273
Pages Used to Set Up Recruitment Templates.....	273
Understanding Recruitment Templates.....	273
Prerequisites.....	275
Recruitment Template Page.....	275
Segmentation Values Page.....	278
<b>Chapter 10: Setting Up Third Party Integrations.....</b>	<b>281</b>
Understanding Third Party Integrations.....	281
The Open Integration Framework.....	281
Job Board Setup.....	282
Resume Extractor Setup.....	282
Background Screener Setup.....	284

Setting Up Recruiting Vendors.....	284
Pages Used to Set Up Recruiting Vendors.....	284
Understanding How to Set Up Recruiting Vendors.....	284
Vendor Setup Page.....	285
Pre-Employment Vendor Setup Page.....	288
Integration Test Page.....	289
Setting Up Autoscreening For Data Received from Vendors.....	290
Page Used To Set Up Autoscreening For Data Received from Vendors.....	290
Understanding Autoscreening.....	290
AutoScreen Setup Page.....	290
Setting Up Data Mapping.....	291
Pages Used to Set Up Data Mapping.....	291
Understanding Data Mapping.....	292
Assigned Mapping Setup Page.....	293
Category Setup Page.....	294
Key List Page.....	295
Value List Page.....	297
Unmapped Data Page.....	297
Key Data Mapping Page.....	298
Value Data Mapping Page.....	300
Inbound Map Page.....	301
Outbound Map Page.....	302
Setting Up Resume Email Accounts.....	303
Pages Used to Define Resume Email Accounts.....	303
Understanding Resume Email Accounts.....	303
Email Setup Page.....	304
Email List Page.....	306
View Email Message/Attachments Page.....	307
Reviewing the Integration Transaction Log.....	308
Pages Used to Review the Integration Transaction Log.....	308
Integration Log Page.....	308
Integration Log Outgoing Msg Page.....	309
<b>Chapter 11: Setting Up Recruitment Sources.....</b>	<b>311</b>
Understanding Recruitment Sources.....	311
Purpose of Recruitment Sources.....	311
The Four Types of Recruitment Sources.....	311
Prerequisites.....	313
Setting Up Recruiting Contacts.....	313
Page Used to Set Up Recruiting Contacts.....	314
Understanding Recruiting Contacts.....	314
Contact Setup Page.....	314
Setting Up Recruitment Sources.....	316
Pages Used to Set Up Recruitment Sources.....	316
Recruitment Sources - Source Setup Page.....	316
Recruitment Sources - Company Page.....	318
Recruitment Sources - Marketing Page.....	319
Recruitment Sources - Employee Page.....	320
Recruitment Sources - Vendor Page.....	321
Recruitment Sources - Contacts Page.....	325
<b>Chapter 12: Understanding Approval Delegation in Talent Acquisition Manager.....</b>	<b>327</b>
Talent Acquisition Manager Delegations.....	327

The Delegation Framework.....	328
Delegation Terminology.....	328
Delegation Options.....	328
Delegation Framework Pages.....	329
Delivered Delegation Definitions for Recruiting.....	329
Delivered Workflow Transactions.....	329
Delivered Permission Lists and Roles for Delegation.....	330
Installation Settings.....	331
Delivered Delegation Transactions.....	331
The Delegation Process.....	331
<b>Chapter 13: Setting Up Searching and Using Global Search.....</b>	<b>333</b>
Understanding Recruiting Search Indexes.....	333
Recruiting Search Indexes.....	333
Search Pages and Their Search Objects.....	334
Index Maintenance.....	336
Faceted Searching.....	336
Maximum Number of Search Results.....	337
Defining Search Index Settings for Recruiting.....	337
Page Used to Define Search Index Settings for Recruiting.....	337
Understanding Search Framework Days To Include Vs. Recruiting Date Settings.....	337
Build Search Index Settings Page.....	338
Building Recruiting Search Indexes.....	340
Deploying and Building Recruiting Search Indexes.....	340
Configuring Recruiting Search Facets.....	341
Date Facet Configuration for Candidate Gateway.....	342
Understanding Global Search for Recruiting.....	346
Recruiting and PeopleSoft Global Search.....	346
Search Indexes and Search Categories.....	347
Permission Lists.....	347
Global Search for Applicants.....	347
Global Search for Job Postings.....	349
Advanced Searches.....	351
<b>Chapter 14: Using Recruiting Pagelets, Pivot Grids, and the Recruiting Home.....</b>	<b>353</b>
Understanding the Recruiting Home.....	353
Defining the Content and Layout of the Recruiting Home.....	354
Pages Used to View and Personalize the Recruiting Home.....	354
Recruiting Home Tile.....	355
Recruiting Home Page.....	355
Personalize Content Page.....	357
Personalize Layout Page.....	359
Viewing the Recruiting Home Pagelets.....	360
Recruiting Home Pagelets and Their Personalization Pages.....	360
Quick Links Pagelet.....	361
My Alerts Pagelet.....	363
Personalize My Alerts Page.....	367
My Job Openings Pagelet.....	368
Personalize My Job Openings Page.....	371
My Applicants Pagelet.....	372
Personalize My Applicants Page.....	375
My Applicant Lists Pagelet.....	375
Personalize My Applicant Lists Page.....	376



Today's Interviews Pagelet.....	377
Time to Fill Pagelet.....	377
Personalize Time to Fill Page.....	379
Browse Job Openings Pagelet.....	379
Browse Applicants Pagelet.....	380
Diversity Analytics Pagelet.....	380
Viewing Detail Pages for the My Alerts Pagelet.....	381
Pages Accessed Exclusively from the My Alerts Pagelet.....	381
Questionnaire Requests Page.....	382
Unevaluated Answers Page.....	384
Unconfirmed Interviews Page.....	385
Interview Evaluations Page.....	386
Offers to Prepare Page.....	387
Open Online Job Offers Page.....	388
Viewing the Recruiting Manager Summary Pagelet.....	390
Recruiting Manager Summary Pagelet and its Personalization Page.....	390
Recruiting Manager Summary Pagelet.....	390
Personalize Recruiting Manager Summary Page.....	394
Viewing Classic Recruiting Pagelets.....	394
Classic Recruiting Pagelets and Their Personalization Pages.....	395
My Job Openings (Classic).....	395
Personalize My Job Openings (Classic) Page.....	398
Search Job Openings (Classic) Pagelet.....	399
Search Applications (Classic) Pagelet.....	400
Recent Job Openings (Classic) Pagelet.....	401
Quick Search (Classic) Pagelet.....	401
Quick Search (Classic) Results Page.....	402
Viewing Recruiting Pivot Grids.....	403
Pages Used to View Recruiting Pivot Grids.....	403
Understanding Recruiting Pivot Grids.....	404
Common Elements for Viewing Pivot Grids.....	404
Job Opening Open and Close Trend Pivot Grid.....	405
Job Opening Aging Analysis Pivot Grid.....	407
In Process Applicants Pivot Grid.....	409
Time to Fill Pivot Grid.....	411
Using Diversity Analytics.....	413
Pages Used for Diversity Analytics.....	413
Understanding Diversity Analytics.....	414
Refresh Diversity Analytics Page.....	415
Applicant Diversity Overview Pivot Grid.....	416
Diversity By Applications Pivot Grid.....	420
<b>Chapter 15: Using the PeopleSoft Fluid User Interface to Manage Recruiting.....</b>	<b>425</b>
Using the Recruiting Homepage.....	425
Recruiting Homepage.....	426
Using the PeopleSoft Fluid User Interface to View My Job Openings.....	427
Pages Used to View My Job Openings Using the PeopleSoft Fluid User Interface.....	428
My Job Openings Tile.....	428
My Job Openings Page.....	428
Using the PeopleSoft Fluid User Interface to View My Applicants.....	434
Pages Used to View My Applicants Using the PeopleSoft Fluid User Interface.....	435
My Applicants Tile.....	435

My Applicants Page.....	435
Using the PeopleSoft Fluid User Interface to View Recruiting Activities.....	440
Pages Used to View Recruiting Activities Using the PeopleSoft Fluid User Interface.....	441
Recruiting Activities Tile.....	442
Recruiting Activities Page.....	442
Using the PeopleSoft Fluid User Interface to View My Applicant Lists.....	443
Pages Used to View Applicant Lists Using the PeopleSoft Fluid User Interface.....	443
Applicant Lists Tile.....	444
My Applicant Lists Page.....	444
Using the PeopleSoft Fluid User Interface to View Interview Schedules.....	445
Pages Used to View Interview Schedules Using the PeopleSoft Fluid User Interface.....	446
Today’s Interviews Tile.....	446
My Interviews Page.....	446
Using the PeopleSoft Fluid User Interface to View Recruiting Alerts.....	448
Pages Used to View Recruiting Alerts Using the PeopleSoft Fluid User Interface.....	448
Recruiting Alerts Tile.....	448
Recruiting Alerts Page.....	449
Personalize Recruiting Alerts.....	452
My Preferences Page.....	454
Taking Action on Pending Approvals Related to Recruiting Using Fluid Approvals.....	454
Pages Used to Take Action on Pending Approvals Related to Recruiting Using Fluid Approvals.....	455
Pending Approvals Page – Job Offer Category.....	455
Pending Approvals – Job Offer Page.....	456
Pending Approvals Page – Job Opening Category.....	456
Pending Approvals – Job Opening Page.....	457
Using the PeopleSoft Fluid User Interface to View Recruiting Analytics.....	458
Pages Used to View Recruiting Analytics Using the PeopleSoft Fluid User Interface.....	458
Understanding Recruiting Pivot Grids.....	459
Common Elements for Viewing Pivot Grids.....	460
Recruiting Insight Tile.....	461
Recruiting Insight Home Page.....	461
Application Details Tile.....	462
Recruiter Pipeline Tile.....	462
Recruitment Admin Dashboard Tile.....	463
Time to Fill Jobs Tile.....	463
Time to Fill Jobs Pivot Grid.....	464
Job Opening Aging Tile.....	465
Job Opening Aging Pivot Grid.....	465
In Process Applicants Tile.....	466
In Process Applicants Pivot Grid.....	467
Jobs Opened/Closed Tile.....	467
Jobs Opened/Closed Pivot Grid.....	468
Applicant Diversity Tile.....	469
Applicant Diversity Pivot Grid.....	470
Applications Diversity Tile.....	471
Applications Diversity Pivot Grid.....	471
Viewing Recruiting Insights.....	472
Pages Used to View Recruiting Insights.....	473
Understanding How to Set Up the Insights Dashboard for Recruiting Analytics.....	473
Recruiting Insight Tile.....	475

Recruiting Insight Home Page.....	475
Application Details Tile.....	476
Application Details Insights Dashboard.....	477
Recruiter Pipeline Tile.....	479
Recruiter Pipeline Dashboard.....	479
Recruitment Admin Dashboard Tile.....	486
Recruitment Admin Dashboard.....	487
Using the PeopleSoft Fluid User Interface to View Recruiting Manager Summary.....	491
Pages Used to View Recruiting Manager Summary Using the PeopleSoft Fluid User Interface.....	491
Recruiting Manager Summary Tile.....	492
Recruiting Manager Summary Page.....	492
Using the PeopleSoft Fluid User Interface to View a Manager’s Open Jobs.....	497
Pages Used to View a Manager’s Open Jobs Using the PeopleSoft Fluid User Interface.....	498
Open Jobs Tile.....	498
Open Jobs Page.....	498
Using the PeopleSoft Fluid User Interface to View Recruiting Activities as a Hiring Manager.....	503
Pages Used to View Recruiting Activities as a Hiring Manager.....	503
Recruiting Activities Tile.....	504
Recruiting Activities Page.....	504
<b>Chapter 16: Creating Job Openings.....</b>	<b>509</b>
Understanding Job Openings.....	509
Job Opening Creation Methods.....	509
Recruitment Templates and the Configurable Display of Job Opening Data.....	509
The Create Job Opening Page and the Manage Job Opening Page.....	510
Understanding Profile Integration for Job Openings.....	511
Profile Architecture.....	511
Profile Integration Options.....	512
Data Loaded from Profiles.....	516
Creating Job Openings.....	519
Pages Used to Create Job Openings.....	519
Understanding Primary Job Opening Information.....	520
Primary Job Opening Information Page.....	521
Combined Profile Information Page.....	526
Job Opening Page.....	530
Send Notification Page.....	535
Entering Basic Job Opening Data.....	537
Pages Used to Enter Basic Job Opening Data.....	537
Job Opening Page: Opening Information Section.....	537
(USF) Candidate Name Requests Page.....	548
Working With Multiple Job Codes in a Job Opening.....	548
Understanding Data That Can Vary By Job Code.....	549
Understanding Copying Qualifications To Non-Primary Job Codes.....	549
Adding Additional Job Codes to a Job Opening.....	550
Copying Job Qualifications to Non-Primary Job Codes.....	551
Adding Staffing and Salary Information.....	552
Page Used to Add Salary and Staffing Information.....	552
Job Opening Page: Staffing Information Section.....	552
Job Opening Page: Salary Information Section.....	554
Adding Job Qualifications.....	556
Pages Used to Define Job Qualifications.....	557

Job Opening Page: Work Experience & Education Section.....	557
Job Opening Page: Profile Combination Section.....	559
Job Opening Page: <Profile Content Type> Section.....	559
<Profile Content Type> Page.....	562
Adding Screening Questions to a Job Opening.....	563
Pages Used to Add Screening Questions to a Job Opening.....	563
Job Opening Page: Screening Questions Section.....	563
Answers to Screening Questions Page.....	566
Assign Evaluators Page.....	567
Select Question Sets Page.....	568
Setting Up Screening for a Job Opening.....	569
Pages Used to Set Up Screening for a Job Opening.....	570
Understanding Screening Settings in the Job Opening.....	570
(USF) Understanding U.S. Federal Screening Setup.....	574
Prerequisites.....	576
Job Opening Page: Applicant Screening Section.....	576
Add Screening Levels Page.....	581
Job Opening - Screening Criteria Page.....	582
Define Screening Points Page (Rating Scale Points).....	590
Define Screening Points Page (Points for Questions).....	591
View Text ID Text Message Page.....	593
Creating Job Postings.....	593
Pages Used to Create Job Postings.....	593
Job Opening Page: Job Postings Section.....	594
Posting Information Page.....	595
Job Description Page.....	600
Identifying Recruiting Team Members for a Job Opening.....	602
Pages Used to Identify Recruiting Team Members for a Job Opening.....	602
Understanding Recruiting Teams.....	602
Teams Page.....	602
Job Opening Page: Assignments Sections.....	603
Add Team Page.....	606
Cloning Job Openings.....	607
Page Used to Clone Job Openings.....	607
Understanding Job Opening Cloning.....	607
Clone Job Opening Page.....	609
Creating Job Openings from Open Positions.....	611
Page Used to Create Job Openings from Positions.....	612
Understanding the Create Job from Position Process.....	612
Create Job Openings from Positions Page.....	613
Approving Job Openings.....	614
Pages Used to Approve Job Openings.....	614
Understanding Setup for Job Opening Approvals.....	614
Understanding How to Approve Job Openings.....	615
Understanding the Delivered Approval Process for Job Openings.....	617
Pending Approvals Page.....	619
Job Opening Page: Approvals Tab.....	620
Insert Additional Approver or Reviewer Page.....	622
Job Opening Page for Fluid Approvals.....	623
Additional Details Page.....	625
Posting Destinations Page.....	625

**Chapter 17: Searching for and Managing Job Openings..... 627**

- Searching for Job Openings..... 627
  - Pages Used to Search for Job Openings..... 627
  - Search Job Openings Page..... 627
  - Browse Job Openings Page..... 633
- Managing Job Openings..... 638
  - Pages Used to Manage Job Openings..... 639
  - Understanding the Manage Job Opening Page..... 640
  - Manage Job Opening Page..... 641
  - Manage Job Opening Page: Applicants Tab..... 644
  - Manage Job Opening Page: Applicant Search Tab..... 655
  - Manage Job Opening Page: Applicant Screening Tab..... 656
  - Manage Job Opening Page: Activity & Attachments Tab..... 657
  - Job Opening Notes Page..... 661
  - Add Expenses Page..... 662
  - Manage Job Opening Page: Details Tab..... 664
- Categorizing Job Openings..... 665
  - Pages Used to Categorize Job Openings..... 665
  - My Job Categories Page..... 665
  - Personalize Job Categories Page..... 667
- Printing Job Openings..... 668
  - Page Used to Print Job Openings..... 668
  - Understanding Job Opening Printing..... 668
  - Select Job Opening Sections Page..... 669
- Viewing Related Content Charts for Job Openings..... 671
  - Pages Used to View Related Content Charts for Job Openings..... 671
  - Understanding Related Content for Job Openings..... 672
  - Received/Rejected Chart..... 672
  - Recruiting Phases Chart..... 673

**Chapter 18: Searching for and Managing Job Postings..... 675**

- Searching for Job Postings..... 675
  - Pages Used to Search for Job Postings..... 675
  - Search Job Postings Page..... 675
  - View Job Posting Page..... 678
- Using the Job Search Agent..... 680
  - Page Used to Run the Job Agent Process..... 680
  - Understanding the Job Agent Process..... 680
  - Prerequisites..... 681
  - Run Job Search Agent Page..... 681
- Managing External Job Postings..... 682
  - Pages Used to Manage External Job Postings..... 682
  - Understanding External Job Postings..... 682
  - Manage External Postings Page..... 683
  - External Posting History Page..... 684
- Posting Jobs to PeopleSoft Services Procurement..... 685
  - Understanding Integration With PeopleSoft Services Procurement..... 686
  - Posting Jobs to PeopleSoft Services Procurement..... 689

**Chapter 19: Creating Applicants and Applications..... 691**

- Understanding Applicant Records..... 691
  - Applicant Record Creation..... 691
  - Applicant-Related Data..... 691

Understanding Profile Information in Job Applications.....	696
Entering Applicant Data.....	697
Page Used to Enter Applicant Data.....	698
Create Applicant Page.....	698
Create Applicant Page: Personal Information Tab.....	701
Create Applicant Page: Applications Tab.....	707
Create Applicant Page: References Tab.....	709
Reference Details Page.....	710
Create Applicant page: Eligibility & Identity Tab.....	711
National Identification Page.....	718
Citizenship Page.....	719
Visa Permit Page.....	719
Bank Account Page.....	720
Disability History Page.....	721
Entering Application Details.....	722
Pages Used to Enter Application Details.....	722
Application Details Page.....	723
View Questionnaire Page.....	739
Work Experience Page.....	741
<Content Type> Page for Applicants.....	742
(USF) Priority Placement Page.....	744
<b>Chapter 20: Searching for and Managing Applicants.....</b>	<b>747</b>
Performing Applicant and Profile Searches.....	747
Pages Used to Search for Applicants.....	747
Understanding Applicant Searches.....	747
Search Applicants Page.....	749
Search Applicants Page: Quick Search Tab.....	750
Search Applicants Page: Keyword Search Tab.....	754
Search Applicants Page: Advanced Search Tab.....	758
Search Applicants Page: Profile Match Tab.....	764
Compare Results Page.....	769
Browse Applicants Page.....	771
Working With Saved Searches.....	774
Pages Used to Work With Saved Searches.....	775
Understanding Saved Searches.....	775
Save Search Page.....	777
Search Applicant Page: Editing Saved Search Mode.....	779
Save Compliance Search Page.....	780
Saved Searches Page.....	781
Automatch Results Page.....	783
Compliance Results Page.....	784
Run Automatch Search Page.....	784
Managing Applicants.....	785
Pages Used to Manage Applicants.....	785
Understanding The Manage Applicant Page.....	786
Manage Applicant Page.....	788
Manage Applicant page: Applicant Activity Tab: Current Status Section.....	791
Applicant Resume Page.....	798
Manage Applicant page: Applicant Activity Tab: Interview Schedule/Evaluation Section.....	799
Manage Applicant Page: Applicant Activity Tab: Expenses Section.....	802
Expenses Page.....	803

Manage Applicant Page: Applicant Activity Tab: History Section.....	804
Manage Applicant Page: Notes Tab.....	805
Manage Applicant page: Applicant Data Tab.....	806
Manage Applicant page: Interested Parties Tab.....	808
Working With Applicant Notes.....	808
Pages Used to Work With Applicant Notes.....	808
Understanding Applicant Notes.....	808
Manage Applicant Page: Notes Tab.....	811
Applicant Notes Page.....	814
Deleting Applicants.....	817
Pages Used to Delete Applicants.....	817
Understanding Application Deletion.....	817
Applicant ID Delete Control Page.....	818
Applicant ID Delete Page.....	819
Applicant ID Delete Log Page.....	821
<b>Chapter 21: Searching for and Managing Applications.....</b>	<b>823</b>
Searching for Applications.....	823
Page Used to Search for Applications.....	823
Understanding Application Searches.....	823
Search Applications Page.....	824
Managing Applications.....	835
Pages Used to Manage Applications.....	835
Understanding the Manage Application Page.....	835
Manage Application Page.....	836
Manage Application Page: Application and Resume Tab.....	842
Manage Application Page: Questionnaire Tab.....	843
Manage Application Page: Notes Tab.....	844
Manage Application Page: Route Tab.....	845
Manage Application Page: Interview Tab.....	846
Edit Final Recommendation Page.....	846
Manage Application Page: Offer Tab.....	847
Manage Application Page: Hire Tab.....	848
Manage Application Page: Other Tab.....	848
<b>Chapter 22: Screening Applicants.....</b>	<b>851</b>
Understanding the Screening Process.....	851
Evaluating Answers to Open-Ended Screening Questions.....	853
Pages Used to Evaluate Open-Ended Questions.....	853
Understanding Open-Ended Question Evaluations.....	853
Evaluate Open Ended Questions Page.....	854
Evaluate OE Answers Page.....	855
(USF) Running the Priority Placement Process.....	856
Page Used to Run the Priority Placement Process.....	856
Understanding the Priority Placement Process.....	857
Process Priority Placement Page.....	857
Running Screening Levels and Applying Results.....	858
Pages Used to Run and Apply Screening Levels.....	858
Understanding Screening Level Processing.....	858
Prerequisites.....	861
Manage Job Opening Page: Applicant Screening Tab: Screening Level Section.....	861
Manage Job Opening Page: Applicant Screening Tab: Screening Results Section.....	864
Screening Details Page.....	869

Questionnaire Results Page.....	873
Rate Applicant Page.....	874
(USF) Set Competitive Status Page.....	876
(USF) Ranking Applicants and Generating the Certificate of Eligibles.....	877
Pages Used to Rank Applicants and Generate the Certificate of Eligibles.....	877
Understanding The Federal Ranking Process.....	878
Prerequisite.....	879
Rank Applicants Page.....	879
Rank Applicants (Details) Page.....	883
Certificate of Eligibles (Certificate Data) Page.....	884
Certificate of Eligibles (Print Certificate) Page.....	885
<b>Chapter 23: Routing Applicants.....</b>	<b>887</b>
Routing Applicants.....	887
Pages Used to Route Applicants.....	887
Understanding Applicant Routing.....	888
Route Applicant Page.....	890
Include Attachments Page.....	895
Preview Notification Page.....	896
Manage Routings Page.....	899
Edit Routing Page.....	901
Routing Response Comments Page.....	903
Route Response Reminder Page.....	904
Entering Routing Responses.....	905
Pages Used to Enter Routing Responses.....	906
Routing Response List Page.....	906
Routing Response Details Page.....	907
Resume Text Page.....	909
<b>Chapter 24: Interviewing Applicants.....</b>	<b>911</b>
Maintaining Interview Facilities.....	911
Page Used to Maintain Interview Facilities.....	911
Interview Facilities Page.....	911
Scheduling and Managing Interviews.....	914
Pages Used to Schedule and Manage Applicant Interviews.....	914
Understanding Applicant Interviews.....	914
Understanding Calendar Integration Options.....	917
Understanding Interview Letters and Notifications.....	918
Manage Interviews Page.....	921
Select Job Opening for Interview Page.....	927
Interview Schedule Page.....	927
Interview Schedule Comments Page.....	941
Interview Schedule (Participant Availability) Page.....	942
Interview Notes Page.....	943
Interview Request Page.....	944
Interview List Page.....	946
Completing Interview Evaluations.....	946
Pages Used to Complete Interview Evaluations.....	947
Understanding Interview Evaluations.....	947
Interview Evaluations (List) Page.....	949
Interview Evaluation Page.....	950
Interview Evaluation Page (Read Only).....	955
Evaluation Rating Comments Page.....	956



Finalizing Interviews and Sending Evaluation Reminders.....	957
Page Used to Finalize Interviews and Send Evaluation Reminders.....	957
Understanding Interview Finalization and Evaluation Reminders.....	957
Interview Evaluation and Finalization Page.....	958
Reviewing Interview Schedules.....	959
Pages Used to Review Interview Schedules.....	959
Interview Summary Page.....	960
Interview Calendar Page.....	961
Recruiter Comments Page.....	963
Interview Team Schedule Page.....	964
<b>Chapter 25: Making Job Offers.....</b>	<b>967</b>
Creating Job Offers.....	967
Pages Used to Prepare Job Offers.....	967
Understanding Job Offers.....	967
Prepare Job Offer Page.....	969
Organizational Level Documents Page.....	982
Document Definitions Page.....	983
Post Online Job Offer Page.....	984
Approving Job Offers.....	985
Pages Used to Approve Job Offers.....	986
Understanding Setup for Offer Approvals.....	986
Understanding How to Approve Job Offers.....	987
Understanding the Delivered Approval Process for Job Offers.....	988
Pending Approvals Page.....	989
Prepare Job Offer Page: Approvals Tab.....	991
Insert Additional Approver or Reviewer Page.....	993
Job Offer Page for Fluid Approvals.....	993
Accepting and Rejecting Offers.....	995
Pages Used to Accept and Reject Offers.....	995
Understanding Offer Acceptance and Rejection.....	995
<Accept/Reject> Offer Page.....	995
<b>Chapter 26: Hiring Applicants.....</b>	<b>999</b>
Hiring Applicants.....	999
Pages Used to Hire Applicants.....	999
Understanding Hiring Applicants.....	999
Prerequisites.....	1002
Prepare For Hire Page.....	1003
Search Results Page.....	1006
Withdraw from Hire Page.....	1008
<b>Chapter 27: Using Actions for Managing Applicants.....</b>	<b>1011</b>
Understanding Actions for Managing Applicants.....	1011
Action Basics.....	1011
Action Availability.....	1013
List of Actions.....	1013
Linking Applicants to Job Openings.....	1017
Page Used to Link Applicants to Job Openings.....	1017
Understanding How to Link Applicants to Job Openings.....	1017
Understanding Questionnaires in Linked Jobs.....	1018
Link Applicant to Job Opening Page.....	1019
Editing Dispositions.....	1023
Page Used to Edit Dispositions.....	1024

Understanding Manual Disposition Changes.....	1024
Edit Disposition Page.....	1026
Rejecting Applicants.....	1028
Page Used to Reject Applicants.....	1028
Reject Applicant Page.....	1028
Withdrawing Applications.....	1030
Page Used to Withdraw an Application.....	1030
Understanding the Withdraw Application Action.....	1030
Withdraw Application Page.....	1032
Printing Application Details.....	1034
Page Used to Print Application Details.....	1034
Understanding the Application Details Report.....	1035
Including Attachments in the Application Details Report.....	1035
Application Report Options Page.....	1036
Print Applications Page.....	1040
Sending Correspondence and Recruitment Letters.....	1042
Pages Used to Send Correspondence and Recruitment Letters.....	1042
Understanding the Send Correspondence Action.....	1043
Understanding Context-Specific Recruitment Letters.....	1045
Send Correspondence Page.....	1048
Send Correspondence Preview Page.....	1058
Find Email Address Page.....	1059
Generate Recruitment Letters Page.....	1060
Forwarding Applicants.....	1060
Pages Used to Forward Applicants.....	1061
Understanding Applicant Forwarding.....	1061
Forward Applicant Page.....	1062
Forward Applicant Preview Page.....	1069
Changing Applicant Statuses.....	1070
Page Used to Change Applicant Statuses.....	1070
Understanding Applicant Statuses.....	1071
Change Applicant Status Page.....	1071
Managing Applicant Lists.....	1072
Pages Used to Manage Applicant Lists.....	1072
Understanding Applicant Lists.....	1072
Applicant Lists Page.....	1073
Add to Applicant List Page.....	1074
Create New List Page.....	1075
Manage Applicant List Page.....	1076
Edit Primary List Information Page.....	1080
Creating Applicant Checklists.....	1080
Page Used to Create Applicant Checklists.....	1080
Understanding Checklists.....	1081
Applicant Checklist Page.....	1081
Adding Persons of Interest.....	1082
Pages Used to Add Persons of Interest.....	1083
Understanding Persons of Interest.....	1083
Add Person of Interest Page.....	1083
Search Results Page.....	1084
Completing Pre-Employment Checks.....	1084
Pages Used to Complete Pre-Employment Checks.....	1084

Understanding Pre-Employment Checks.....	1084
Prerequisite.....	1084
Pre-Employment Check Page.....	1085
Creating Applicant Contracts.....	1086
Pages Used to Manage Applicant Contracts.....	1086
Understanding Applicant Contracts.....	1086
Prerequisites.....	1086
Contract Status/Content Page.....	1086
Contract Clause Page.....	1087
Signature Date/Probation Info Page.....	1088
(AUS) Creating Salary Packages.....	1089
(AUS) Copying Salary Packages to Human Resources.....	1090
Processing Duplicate Applicants.....	1090
Pages Used to Process Duplicate Applicants.....	1090
Understanding Duplicate Applicant Processing.....	1091
Process Duplicate Applicants Page.....	1094
Find Duplicate Applicants Page.....	1096
Review Duplicate Applicants Page.....	1098
Merge Applicant Page.....	1101
<b>Chapter 28: Managing Resumes.....</b>	<b>1105</b>
Understanding Resume Management.....	1105
Channels.....	1105
Understanding the Resume Extraction Process.....	1107
Understanding Resume Statuses.....	1108
Loading Resumes.....	1110
Page Used to Load Resumes.....	1110
Understanding the Resume Load Process (HRS_RESLOAD).....	1110
Prerequisites.....	1111
Load Resume - Prepare Load Parameters Page.....	1112
Managing Resumes.....	1116
Pages Used to Manage Resumes.....	1116
Understanding Resume Management.....	1116
Prerequisite.....	1116
Manage Resumes - Select Resume Page.....	1117
Resume Management Details Page.....	1120
<b>Chapter 29: Managing Employee Referral Programs.....</b>	<b>1123</b>
Understanding the Employee Referral Program Process.....	1123
Understanding How Referrals are Submitted.....	1124
Setting Up Employee Referral Programs.....	1125
Pages Used to Set Up Employee Referral Programs.....	1126
Understanding How to Set Up Employee Referral Programs.....	1127
Employee Eligibility Rules Page.....	1128
Referral Eligibility Rules - Rule SQL Page.....	1129
Award Category Rules Page.....	1130
Referral Category Rules - Rule SQL Page.....	1131
Award Schedule Page.....	1132
Employee Referral Programs Page.....	1133
Employee Referral Program - Criteria Page.....	1134
Employee Referral Program - Rules Page.....	1137
Managing Hot Jobs.....	1139
Pages Used to Manage Hot Jobs.....	1139

Understanding Hot Jobs.....	1140
Hot Jobs Page.....	1141
Hot Jobs - Selection Page.....	1142
Hot Jobs - Job Openings Page.....	1143
Hot Jobs - Award Schedule Page.....	1143
Hot Job History Page.....	1144
Processing Employee Referrals.....	1144
Page Used to Process Eligibility and Awards.....	1144
Understanding the Employee Referral Program Process.....	1144
Understanding Payment Statuses.....	1147
Process Referral Programs Page.....	1149
Reviewing and Overriding Referral Awards.....	1150
Pages Used to View and Override Referral Awards.....	1150
Understanding Referral Overrides.....	1150
Referral Administration Page.....	1151
Administer Referrals - Eligibility page.....	1151
Administer Referrals - Awards Page.....	1153
Referral Award Details Page.....	1154
Application Summary Page.....	1157
Track Duplicate Referrals Page.....	1158
Eligibility Overrides Page.....	1159
Award Overrides Page.....	1160
Approving and Paying Referral Awards.....	1161
Pages Used to Approve and Pay Referral Awards.....	1161
Understanding Award Approvals.....	1161
Understanding Paying Awards.....	1162
Approve Employee Awards Page.....	1164
Process Referral Programs Page.....	1165
Rejected Awards Page.....	1165
Referral Award Details Page.....	1166
<b>Chapter 30: Action Availability Reference.....</b>	<b>1167</b>
Action Availability Reference.....	1167
<b>Chapter 31: Delivered Workflows for Talent Acquisition Manager.....</b>	<b>1175</b>
Delivered Workflows for Talent Acquisition Manager.....	1175
Job Offer Approval.....	1175
Job Offer Approved.....	1176
Job Offer Deny.....	1176
Job Offer Error.....	1177
Job Offer Escalation.....	1178
Job Offer Review.....	1179
Job Offer Termination.....	1180
Job Opening Approval.....	1180
Job Opening Approved.....	1181
Job Opening Deny.....	1182
Job Opening Error.....	1183
Job Opening Escalation.....	1183
Job Opening Review.....	1184
Job Opening Termination.....	1185
Delivered Notification Templates.....	1186
<b>Chapter 32: Delivered Permission Lists and Roles for Talent Acquisition Manager.....</b>	<b>1197</b>
Delivered Permission Lists and Roles.....	1197

<b>Chapter 33: PeopleSoft Talent Acquisition Manager Reports.....</b>	<b>1205</b>
Talent Acquisition Manager Reports: A to Z.....	1205



# Preface

---

## Understanding the PeopleSoft Online Help and PeopleBooks

The PeopleSoft Online Help is a website that enables you to view all help content for PeopleSoft applications and PeopleTools. The help provides standard navigation and full-text searching, as well as context-sensitive online help for PeopleSoft users.

### Hosted PeopleSoft Online Help

You can access the hosted PeopleSoft Online Help on the [Oracle Help Center](#). The hosted PeopleSoft Online Help is updated on a regular schedule, ensuring that you have access to the most current documentation. This reduces the need to view separate documentation posts for application maintenance on My Oracle Support. The hosted PeopleSoft Online Help is available in English only.

To configure the context-sensitive help for your PeopleSoft applications to use the Oracle Help Center, see [Configuring Context-Sensitive Help Using the Hosted Online Help Website](#).

### Locally Installed PeopleSoft Online Help

If you're setting up an on-premises PeopleSoft environment, and your organization has firewall restrictions that prevent you from using the hosted PeopleSoft Online Help, you can install the online help locally. Installable PeopleSoft Online Help is made available with selected PeopleSoft Update Images and with PeopleTools releases for on-premises installations, through the [Oracle Software Delivery Cloud](#).

Your installation documentation includes a chapter with instructions for how to install the online help for your business environment, and the documentation zip file may contain a README.txt file with additional installation instructions. See *PeopleSoft 9.2 Application Installation* for your database platform, "Installing PeopleSoft Online Help."

To configure the context-sensitive help for your PeopleSoft applications to use a locally installed online help website, see [Configuring Context-Sensitive Help Using a Locally Installed Online Help Website](#).

### Downloadable PeopleBook PDF Files

You can access downloadable PDF versions of the help content in the traditional PeopleBook format on the [Oracle Help Center](#). The content in the PeopleBook PDFs is the same as the content in the PeopleSoft Online Help, but it has a different structure and it does not include the interactive navigation features that are available in the online help.

### Common Help Documentation

Common help documentation contains information that applies to multiple applications. The two main types of common help are:

- Application Fundamentals

- Using PeopleSoft Applications

Most product families provide a set of application fundamentals help topics that discuss essential information about the setup and design of your system. This information applies to many or all applications in the PeopleSoft product family. Whether you are implementing a single application, some combination of applications within the product family, or the entire product family, you should be familiar with the contents of the appropriate application fundamentals help. They provide the starting points for fundamental implementation tasks.

In addition, the *PeopleTools: Applications User's Guide* introduces you to the various elements of the PeopleSoft Pure Internet Architecture. It also explains how to use the navigational hierarchy, components, and pages to perform basic functions as you navigate through the system. While your application or implementation may differ, the topics in this user's guide provide general information about using PeopleSoft applications.

## Field and Control Definitions

PeopleSoft documentation includes definitions for most fields and controls that appear on application pages. These definitions describe how to use a field or control, where populated values come from, the effects of selecting certain values, and so on. If a field or control is not defined, then it either requires no additional explanation or is documented in a common elements section earlier in the documentation. For example, the Date field rarely requires additional explanation and may not be defined in the documentation for some pages.

## Typographical Conventions

The following table describes the typographical conventions that are used in the online help.

<b><i>Typographical Convention</i></b>	<b><i>Description</i></b>
<b>Key+Key</b>	Indicates a key combination action. For example, a plus sign (+) between keys means that you must hold down the first key while you press the second key. For <b>Alt+W</b> , hold down the <b>Alt</b> key while you press the <b>W</b> key.
... (ellipses)	Indicate that the preceding item or series can be repeated any number of times in PeopleCode syntax.
{ } (curly braces)	Indicate a choice between two options in PeopleCode syntax. Options are separated by a pipe ( ).
[ ] (square brackets)	Indicate optional items in PeopleCode syntax.
& (ampersand)	When placed before a parameter in PeopleCode syntax, an ampersand indicates that the parameter is an already instantiated object.  Ampersands also precede all PeopleCode variables.



<b>Typographical Convention</b>	<b>Description</b>
⇒	This continuation character has been inserted at the end of a line of code that has been wrapped at the page margin. The code should be viewed or entered as a single, continuous line of code without the continuation character.

## ISO Country and Currency Codes

PeopleSoft Online Help topics use International Organization for Standardization (ISO) country and currency codes to identify country-specific information and monetary amounts.

ISO country codes may appear as country identifiers, and ISO currency codes may appear as currency identifiers in your PeopleSoft documentation. Reference to an ISO country code in your documentation does not imply that your application includes every ISO country code. The following example is a country-specific heading: "(FRA) Hiring an Employee."

The PeopleSoft Currency Code table (CURRENCY\_CD\_TBL) contains sample currency code data. The Currency Code table is based on ISO Standard 4217, "Codes for the representation of currencies," and also relies on ISO country codes in the Country table (COUNTRY\_TBL). The navigation to the pages where you maintain currency code and country information depends on which PeopleSoft applications you are using. To access the pages for maintaining the Currency Code and Country tables, consult the online help for your applications for more information.

## Region and Industry Identifiers

Information that applies only to a specific region or industry is preceded by a standard identifier in parentheses. This identifier typically appears at the beginning of a section heading, but it may also appear at the beginning of a note or other text.

Example of a region-specific heading: "(Latin America) Setting Up Depreciation"

### Region Identifiers

Regions are identified by the region name. The following region identifiers may appear in the PeopleSoft Online Help:

- Asia Pacific
- Europe
- Latin America
- North America

### Industry Identifiers

Industries are identified by the industry name or by an abbreviation for that industry. The following industry identifiers may appear in the PeopleSoft Online Help:

- USF (U.S. Federal)

- E&G (Education and Government)

## Translations and Embedded Help

PeopleSoft 9.2 software applications include translated embedded help. With the 9.2 release, PeopleSoft aligns with the other Oracle applications by focusing our translation efforts on embedded help. We are not planning to translate our traditional online help and PeopleBooks documentation. Instead we offer very direct translated help at crucial spots within our application through our embedded help widgets. Additionally, we have a one-to-one mapping of application and help translations, meaning that the software and embedded help translation footprint is identical—something we were never able to accomplish in the past.

---

## Using and Managing the PeopleSoft Online Help

Select About This Help in the left navigation panel on any page in the PeopleSoft Online Help to see information on the following topics:

- Using the PeopleSoft Online Help.
- Managing hosted Online Help.
- Managing locally installed PeopleSoft Online Help.

---

## PeopleSoft HCM Related Links

[Oracle Help Center](#)

[PeopleSoft Online Help Home](#)

[PeopleSoft Information Portal](#)

[My Oracle Support](#)

[PeopleSoft Training from Oracle University](#)

[PeopleSoft Video Feature Overviews on YouTube](#)

[PeopleSoft Business Process Maps \(Microsoft Visio format\)](#)

[HCM Abbreviations](#)

[PeopleSoft Spotlight Series](#)

---

## Contact Us

Send your suggestions to [pssoft-infodev\\_us@oracle.com](mailto:pssoft-infodev_us@oracle.com).

Please include the applications update image or PeopleTools release that you're using.

---

## Follow Us

<i>Icon</i>	<i>Link</i>
	<a href="#"><u>Watch PeopleSoft on YouTube</u></a>
	<a href="#"><u>Follow @PeopleSoft_Info on X.</u></a>
	<a href="#"><u>Read PeopleSoft Blogs</u></a>
	<a href="#"><u>Connect with PeopleSoft on LinkedIn</u></a>



# Getting Started with Talent Acquisition Manager

---

## Talent Acquisition Manager Overview

Talent Acquisition Manager is a complete, integrated system that enables organizations to effectively manage workforce acquisition across all employment categories. Whether you have a few resumes to fill hard-to-find positions or you have plenty of resumes but top candidates are scarce, Talent Acquisition Manager is ideally suited to meet your needs in any type of hiring conditions. Streams of applicants can be screened, interviewed, and hired quickly and efficiently.

### Primary Recruiting Process Flow

With this application, you can:

- Create and manage job openings.
- Enter and manage applicant information.
- Manage job postings.
- Search for job openings and applicants.
- Screen applicants.
- Route applicants.
- Manage applicant interviews.
- Manage offers.
- Prepare applicants for hire.

This diagram outlines the Talent Acquisition Manager recruitment process flow. The flow starts with job openings and applicant data, and continues through screening, routing, interviewing, making offers, and hiring applicants.

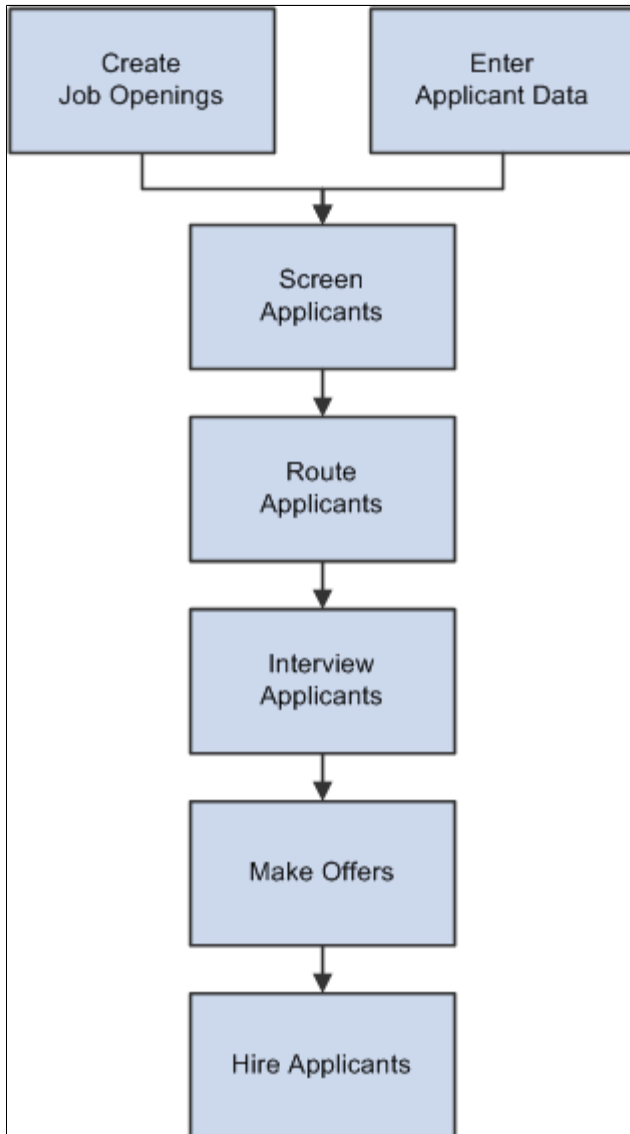

## Recruiting Home

The Recruiting Home page provides a variety of pagelets that provide access to key data from your recruiting system, including

- Quick Links
- My Alerts

This pagelet provides recruiters with summary information for the recruiters own job openings. For example, there are alerts related to new applicants, interviews and interview evaluations, pending approvals, and expiring job offers.

- My Job Openings

- My Applicants
- Browse Job Openings
- Browse Applicants
- Today's Interviews
- Time to Fill

## Additional Recruiting Functionality

In addition to the features that are available to help you manage the recruiting process, you can also:

- Create and manage employee referral programs.
- Use the text catalog to modify much of the text that appears on the applicant facing pages.

The text catalog contains the default text, but you can change the default text as needed. The text catalog enables you to change text for:

- Page titles.
- Page instructions.
- Link titles.
- Group box labels.
- Field labels.

See “Configuring the Text Catalog” (Application Fundamentals).

- Manage recruiting security.

*Recruiting Role Types* enable you to group standard PeopleTools roles to control certain recruiting privileges. The *Recruiter*, *Hiring Manager*, and *Recruitment Administrator* recruiting role types each have specific privileges.

The recruiting system also includes logic to control user access to specific job openings and applicants.

For more information, see [Understanding Recruiting Security](#).

---

## Talent Acquisition Manager Integrations

The following diagram shows Talent Acquisition Manager integrations with PeopleSoft Human Resources, PeopleSoft Candidate Gateway, and various external system that integrate using the open integration framework:

This diagram illustrates Talent Acquisition Manager integrations with PeopleSoft applications and external systems.

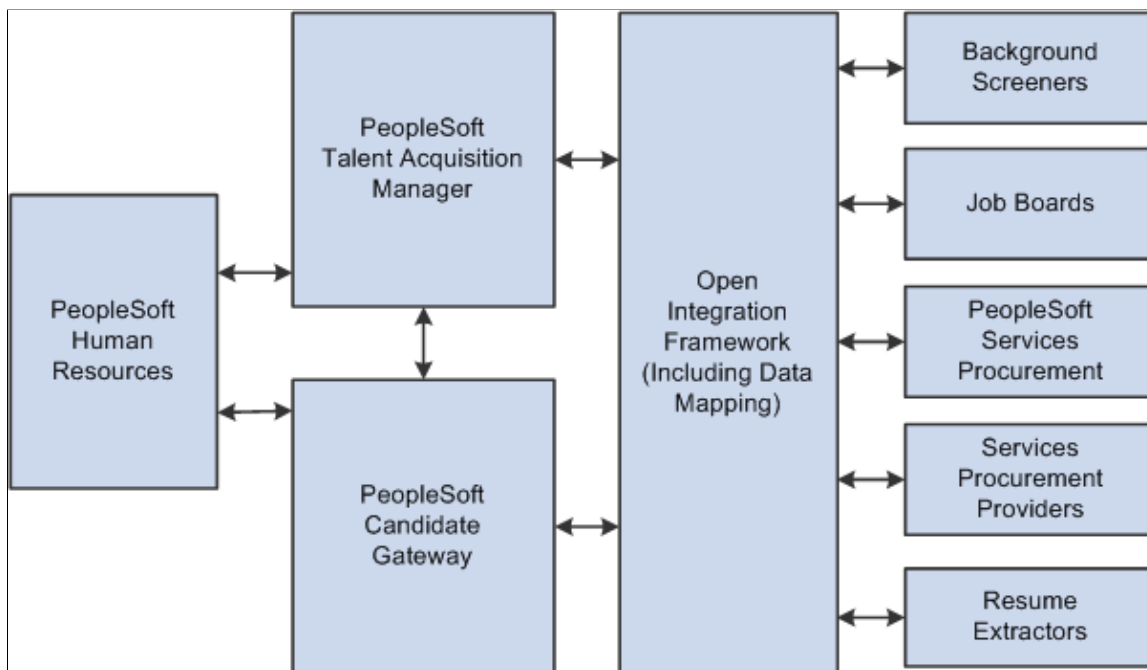

Supplemental information about third-party application integrations is located on the PeopleSoft My Oracle Support website.

## Talent Acquisition Manager Implementation

PeopleSoft Setup Manager enables you to generate a list of setup tasks for your organization based on the features that you are implementing. The setup tasks include the components that you must set up, listed in the order in which you must enter data into the component tables, and links to the corresponding documentation.

PeopleSoft Talent Acquisition Manager also provides component interfaces that help you load data from your existing system into PeopleSoft Talent Acquisition Manager Integrations tables. Use the Excel to Component Interface utility with the component interfaces to populate the tables.

This tables lists components that have component interfaces:

<b>Component</b>	<b>Component Interface</b>	<b>References</b>
HRS_QSTN_SET_DEF	HRS_QSTN_SET_DEF_CI	See <a href="#">Recruiting Question Set Page</a> .
HRS_QSTN_DEF	HRS_QSTN_DEF_CI	See <a href="#">Recruiting Question Definition Page</a> .
HRS_LOCATION	HRS_LOCATION_CI	See <a href="#">Setting Up Recruiting Locations</a> .



Refer to the *PeopleSoft HCM 9.2 - Reorganization of Component Interface Permissions* (Doc ID [2342162.1](#)) MOS posting for a list of system-delivered CIs and their usage, the mapping of CIs and associated permission lists, and the mapping of CI permission lists and user roles.



## Chapter 2

# Defining System-Wide Settings for Recruiting

---

## Understanding Foundation Data for Recruiting

This overview discusses the following types of HCM foundation data and HCM common frameworks that are used in PeopleSoft Recruiting Solutions:

- [The HCM Installation Table](#)
- [HCM Foundation Tables](#)
- [Human Resources Profile Data](#)
- [PeopleSoft HCM Common Frameworks](#)
- [Optional Human Resource Definitions](#)

## The HCM Installation Table

The HCM Installation Table includes a variety of system-wide settings that affect PeopleSoft Recruiting Solutions. For example, use this component to:

- Identify the installed applications for your PeopleSoft implementation.
- Define whether your system uses full, partial, or no position management.
- Choose whether to collect applicant ethnicity information in the older one-question format or the newer two-question format.

See “Setting Up Implementation Defaults” (Application Fundamentals)

## HCM Foundation Tables

PeopleSoft Recruiting Solutions uses the common PeopleSoft HCM tables for foundation data such as:

- Organizational data, including business units, companies, departments, and locations.
- Job attributes, including job codes and job families.
- Currency data, including currency codes.

### Related Links

Application Fundamentals

## Human Resources Profile Data

Profiles are widely used by organizations to describe the attributes of jobs or individuals. Typically, profiles summarize the competencies, qualifications, and skills of a job or a person. The Manage Profiles business process in PeopleSoft Human Resources provides a framework for developing and managing profiles that meet your industry or organizational requirements.

During the recruitment process, PeopleSoft Talent Acquisition Manager uses profiles to capture job requirements and applicant qualifications.

Use PeopleSoft Human Resources Manage Profiles to set up profiles to capture job and applicant attributes (for example, competencies, degrees, or licenses) that matter to the recruiting process.

## PeopleSoft HCM Common Frameworks

Recruiting Solutions uses several common frameworks that are shared by all PeopleSoft HCM applications. The following table lists these frameworks and provides links to additional documentation.

<i>Framework</i>	<i>Reference</i>
Approval Framework	“Understanding Approvals” (Application Fundamentals)
Delegation Framework	“Understanding Delegation” (Enterprise Components)
Text Catalog (used primarily for Candidate Gateway pages)(	“Configuring the Text Catalog” (Application Fundamentals)
Attachments Framework (used only for online job offers)	“Configuring and Working With Attachments” (Application Fundamentals)
Configurable Toolbars	<p>Configuring Toolbars</p> <hr/> <p><b>Note:</b> Many pages in Talent Acquisition Manager use the configurable toolbar. These preconfigured toolbars include a Return button for going back to the previous page. If you are on PeopleTools 8.55 or higher, the generic banner at the top of PeopleSoft pages already includes a Back button, so consider using the toolbar framework to remove the Return button from the toolbars on the application pages.</p> <hr/>

## Optional Human Resource Definitions

PeopleSoft Recruiting Solutions provides optional integration with certain PeopleSoft Human Resources business processes. The functionality that you configure for these business processes automatically extends into the recruiting system without the need for any recruiting-specific setup tasks other than the optional activation of works council approvals.

The following table lists these business processes and provides links to additional documentation.

<b>PeopleSoft Human Resources Business Process</b>	<b>How Used</b>	<b>Reference</b>
Manage Positions	The Manage Positions business process helps you define Human Resources by position rather than job or by employee. PeopleSoft Recruiting Solutions supports all position management options: full, partial, and none. Your position management setting controls whether job codes, position numbers, or both are tracked in job openings.	“Using Positions Versus Jobs to Structure Your HR System” (PeopleSoft Human Resources Manage Positions)
Administer Workforce - Contract Administration	If you use the contract administration functionality in the Administer Workforce business process, you can use the same functionality to set up contracts for applicants in PeopleSoft Recruiting Solutions. If you hire the applicant, the system can copy the applicant's contract into the employee record.	“Tracking Workforce Contracts” (PeopleSoft Human Resources Administer Workforce)
(AUS) Administer Salary Packaging	If you use the Administer Salary Packaging process in PeopleSoft Human Resources, you can use the same functionality to model salary packages for applicants in PeopleSoft Recruiting Solutions. If you hire the applicant, the system can copy the applicant's salary packaging information into the employee record.	“Understanding Salary Package Modelling” (PeopleSoft Human Resources Administer Salary Packaging)
Manage Labor Relations	If your organization does business in countries where workers can belong to works councils, and if you use the Manage Labor Administration process to set up works councils and works council approval processing, then you can optionally set up the recruiting system to require works council approvals for job offers.	“Setting Up Works Councils” (PeopleSoft Human Resources Manage Labor Administration)

---

## Setting Up Recruiting Installation Settings

To set up implementation defaults for both PeopleSoft Talent Acquisition Manager and PeopleSoft Candidate Gateway, use the Recruiting Installation (HRS\_INST) component.

## Pages Used to Set Up Talent Acquisition Manager Implementation Defaults

<b>Page Name</b>	<b>Definition Name</b>	<b>Usage</b>
<u>Recruiting Installation - General Page</u>	HRS_INST	Define system-wide settings for recruiting templates, flexible processes, approval processing, and integrations.
<u>Recruiting Installation – Jobs Page</u>	HRS_INST_JOBOPNING	Define additional system-wide settings, particularly settings related to job openings, job postings, and applicant search autosave.
<u>Recruiting Installation – Manage Jobs Page</u>	HRS_MJ_INST	Define display settings for applicants.
<u>Recruiting Installation – Applicants Page</u>	HRS_INST_APPLICANT	Define system-wide settings for applicants.
<u>Online Job Offers – Select Regulatory Regions Page</u>	HRS_ONL_OFR_RG_SEC	Select the regulatory regions where you allow online job offers.
<u>Recruiting Installation – Last Assigned IDs Page</u>	HRS_INST_CNTRS	Specify starting numbers for system-assigned numbers. These should be set to a number that does not overlap with existing values in the database or you will get duplicate value errors.

### Recruiting Installation - General Page

Use the Recruiting Installation - General page (HRS\_INST) to define system-wide settings for recruiting templates, flexible processes, approval processing, and integrations.

Navigation:

**Set Up HCM > Install > Product Specific > Recruiting Installation > General**

This example illustrates the Recruiting Installation - General page.

**Template Settings** ?

\*Template Segmenting Type

**Default Templates** ?

Standard Requisition	<input type="text" value="Requisition Default"/>
Continuous Job Opening	<input type="text" value="Continuous Default Apprv OFF"/>
Interview Evaluation	<input type="text" value="Default Interview"/>

**Default Flexible Processes** ?

Job Creation Process ID	<input type="text"/>	<input type="text" value=""/>
Recruiting Process ID	<input type="text" value="1000"/>	<input type="text" value="Service Job Opening"/>

**Approvals Required**

<input type="checkbox"/> Standard Requisition	<input checked="" type="checkbox"/> Job Offers
<input type="checkbox"/> Continuous Job Opening	<input type="checkbox"/> Optional Works Council

**Integration Settings** ?

*Allow Profile Utilization	<input type="text" value="Yes"/>
*Person Profile Integration	<input type="text" value="Yes"/>
*Calendar Integration	<input type="text" value="Partial Integration"/>

## Template Settings

<b>Field or Control</b>	<b>Description</b>
<p><b>Template Segmenting Type</b></p>	<p>Select a type of data that the system will use to associate specific recruitment templates with specific job openings.</p> <p>When you set up a recruitment template, you use the <a href="#">Segmentation Values Page</a> to associate the template with specific values for the selected segmenting type. For example, if the segmenting type is <i>Department</i>, then you can associate different recruitment templates with different departments in your organization. This enables you to vary the job opening data and layout by department.</p> <p>A field corresponding to the selected segmenting type always appears on the <a href="#">Primary Job Opening Information Page</a>, and users are required to enter a value in that field. This enables the system to apply the appropriate recruitment template. After continuing past the Primary Job Opening Information page, you cannot modify the value you provide for the segmenting type field. This value is displayed as a read-only field in the job opening header.</p> <p>Available segmenting types are:</p> <ul style="list-style-type: none"> <li>• <i>Business Unit</i></li> <li>• <i>Company</i></li> <li>• <i>Department</i></li> <li>• <i>Job Code</i></li> <li>• <i>Job Family</i></li> <li>• <i>Job Profile</i></li> <li>• <i>Salary Grade</i></li> </ul> <p>When you segment by Job Profile, users can enter a JOB profile on the Primary Job Opening Information page, and the system imports compatible job profile data into the new job opening.</p> <p>For purposes of importing job profile data into a job opening, segmentation by job profile functionality is superseded by profile integration, which you activate by selecting <i>Yes</i> in the Allow Profile Utilization field on this page. Although the system does not prevent you from using both options, Oracle does not recommend that configuration.</p>



## Default Templates

<b><i>Field or Control</i></b>	<b><i>Description</i></b>
<b>Standard Requisition and Continuous Job Opening</b>	<p>Select the default recruitment template for your standard requisitions and your continuous job openings. The system uses these templates for new job openings when there is not another template that is associated with the specific segmenting value you've entered.</p> <p>For example, if your job openings are segmented by department (because you entered <i>Department</i> in the Template Segmenting Type field on this page), then when you create a job opening, you will enter a specific department. If there is a recruitment template associated with that department, then the system uses the department-specific template to control the content and layout of information on the job opening pages.</p> <p>If there isn't a department specific recruitment template, then the system uses the appropriate default recruitment template, depending on whether the job opening is a standard requisition or a continuous job opening.</p>
<b>Interview Evaluation</b>	<p>Select the default interview evaluation template.</p> <p>The system uses this template when an applicant is being evaluated and is not linked to any job opening, or when the job opening's recruitment template does not include an interview evaluation template.</p>

## Default Flexible Processes

<i>Field or Control</i>	<i>Description</i>
<b>Job Creation Process ID and Recruiting Process ID</b>	<p>Use these fields to define system-wide default flexible processes. A flexible job creation process provides role-specific restrictions on which job opening fields are visible during the job opening creation process. A flexible recruiting process provides role-specific and context-specific restrictions on actions that users can perform and dispositions that users can manually assign.</p> <p>The system uses these default flexible processes when a job opening’s recruitment template does not find a flexible process based on the job opening data.</p> <p>Leave these fields blank if you are not implementing flexible processes or if you are implementing flexible process only for job openings with specific recruiting templates.</p> <p>If a job opening does not use a flexible job creation process, it displays all job opening fields to all users during the job creation process.</p> <p>If a job opening does not use a flexible recruiting process, it allows all users to access all actions (subject to any action-specific validations) and it allows all users to manually assign any disposition to any applicant.</p> <p>See <a href="#">Understanding Flexible Processes</a>.</p>

## Approvals Required

This group box is used to activate the two approval processes, JobOpening and JobOffer, used by Talent Acquisition Manager. Approvals are created using the Approval Framework.

See “Understanding Approvals” (Application Fundamentals).

<i>Field or Control</i>	<i>Description</i>
<b>Standard Requisition</b>	Select this check box to activate approvals when creating job openings with a type of standard requisition.
<b>Job Offers</b>	Select this check box to activate approvals when creating a job offer.
<b>Continuous Job Opening</b>	Select this check box to activate approvals when creating job openings with a type of continuous job opening.

<b>Field or Control</b>	<b>Description</b>
<b>Optional Works Council</b>	<p>Select this check box to activate approvals when creating job offers requiring works council approval.</p> <p>When you select this option, the Works Council Information section appears as an option in the Job Opening Template and Job Opening pages.</p> <p>This check box is available for selection only if the <b>Job Offers</b> check box is selected.</p>

## Integration Settings

<b>Field or Control</b>	<b>Description</b>
<b>Allow Profile Utilization</b>	<p>Select <i>Yes</i> to activate profile integration, or select <i>No</i> to disable this integration.</p> <p>If profile integration is active, users who create job openings can select up to three profiles whose characteristics will be imported into the newly created job opening.</p> <p>If your Template Segmenting Type is <i>Job Profile</i>, then job openings are already configured to import characteristics of a profile that you select when you create the job. If you segment by job profile <i>and</i> you allow profile utilization, then users must select one job profile because of the segmenting rule, and can optionally select up to two more person and non-person profiles (for a total of three) because of the profile utilization setting.</p> <p>In this situation, segmenting by job profile serves for recruitment template selection, but it does not offer any additional profile capabilities, it only enforces the selection of at least one profile and limits the number of other profiles that can be selected during job opening creation.</p> <p>Generally, organizations that allow profile utilization will not also segment by profile.</p> <hr/> <p><b>Note:</b> If you select <i>No</i>, the system disregards any profile integration settings on the <a href="#">Recruitment Template Page</a></p> <hr/>

<b>Field or Control</b>	<b>Description</b>
<b>Person Profile Integration</b>	<p>When profile utilization is not allowed at all, this system sets the value to <i>No</i> and makes the field read-only.</p> <p>However, if you allow profile utilization, use this field to determine which types of profiles can be selected when a user creates a job opening. Select <i>Yes</i> to enable users to select both person and non-person profiles, or select <i>No</i> to limit profile selection to non-person profiles.</p> <p>Even if users can select person profiles, they can select only person profiles for people to whom they normally have security access (such as direct reports).</p>
<b>Calendar Integration</b>	<p>Select <i>Partial Integration</i> to send interview schedules to participants as an iCalendar attachment. The participant can import the iCalendar meeting request and act on it. This is a one-way message, and TAM does not get any response back from the participant.</p> <p>Select <i>No Integration</i> if you do not want to use any calendar integration.</p> <p>The <i>Full Integration</i> option is no longer supported.</p>

## Recruiting Installation – Jobs Page

Use the Recruiting Installation – Jobs page (HRS\_INST\_JOBOPNING) to define additional system-wide settings, particularly settings related to job openings, job postings, and applicant search autosave.

Navigation:

**Set Up HCM > Install > Product Specific > Recruiting Installation > Jobs**

This example illustrates the Recruiting Installation - Jobs page.

### Job Opening Settings

\*Allow Multiple Jobs/Positions

Randomize Screening Questions

Randomize Screening Answers

Enable Job Categorization

Maximum Applicants Displayed

Default Funnel Phase

Default Job Status for Browse Job Openings Page

### Job Posting Settings ?

Max Job Posts per Notification

Max Jobs Returned from Search

Configure Multiple Job Posting Descriptions

### My Job Openings Settings

My Job Openings Page Maximum Results

My Association

Job Opening Status

## Job Opening Settings

<i>Field or Control</i>	<i>Description</i>
<b>Allow Multiple Jobs/Positions</b>	Select <i>Yes</i> if you want to allow multiple jobs or positions within one job opening, otherwise select <i>No</i> .  See <a href="#">Working With Multiple Job Codes in a Job Opening</a> .

<b>Field or Control</b>	<b>Description</b>
<p><b>Randomize Screening Questions</b></p>	<p>Select <i>Yes</i> if you want applicant questionnaires to present questions in random order, disregarding the any assigned order numbers. When an applicant applies for multiple jobs openings, questions from all job openings are randomized together.</p> <p>Select <i>No</i> to order questions based on the order numbers specified in the qualifications section of the job opening details (for job-specific screening questions) or in the resume template (for questions when an application is not associated with any job openings).</p> <p>Regardless of the value you select, open-ended questions always appear after multiple-choice questions.</p>
<p><b>Randomize Screening Answers</b></p>	<p>Select <i>Yes</i> if you want applicant questionnaires to present answers to multiple choice questions (including yes/no questions) in random order.</p> <p>Select <i>No</i> to order answers according to the settings in the question definition. If the question definition does not specify an order, the default order is by answer ID.</p>
<p><b>My Job Openings Pagelet Maximum Results</b></p>	<p>Enter the maximum number of job openings to be listed in the <a href="#">My Job Openings Pagelet</a> on the Recruiting Home page. Choose a value that balances your usability needs and your performance requirements. The default value is 300.</p>
<p><b>Enable Job Categorization</b></p>	<p>Select <i>Yes</i> to activate job categorization functionality. Job categories are personal tags that Talent Acquisition Manager users assign to job openings so that they can easily track, organize and group their jobs openings. Categories are associated with specific user IDs, so different users can categorize job openings according to their own needs.</p> <p>Categories are visible on the My Job Openings pagelet, the Browse Job Opening page, the Search Job Opening page, and the Manage Job Opening page.</p> <p>Select <i>No</i> to disable job categorization functionality.</p>
<p><b>Maximum Applicants Displayed</b></p>	<p>Enter the maximum number of applicants to be listed on the <a href="#">Manage Job Opening Page: Applicants Tab</a>. Setting an appropriate maximum improves performance for job openings with very large numbers of applicants.</p>

<b>Field or Control</b>	<b>Description</b>
<b>Default Funnel Phase</b>	<p>Choose a recruiting phase to use as the default selection for the phase filter on the Manage Job Opening page: Applicants tab. The default value is <i>0 - All</i>, representing all phases in the recruiting process.</p> <p>When a job opening does not have any applicants in the default phase, the system uses <i>0 - All</i> for the phase filter rather than using the default phase that you select here.</p>
<b>Default Job Status for Browse Job Openings Page</b>	<p>Select a job opening status to use as a default filter on the <a href="#">Browse Job Openings Page</a>. For example, if users typically use the Browse Job Openings page to work with current job openings, you can set the default status to <i>010 - Open</i>. Users can always clear the filtering criteria to see job openings in other statuses.</p>

### Job Posting Settings

<b>Field or Control</b>	<b>Description</b>
<b>Max Job Posts per Notification</b>	<p>Enter the maximum number of job postings that can be listed in a Job Agent email notification. If the Job Agent search criteria finds more job postings than are allowed, the email lists as many as are allowed and then appends a message directing the recipient to visit Candidate Gateway to view all search results.</p> <p>The maximum value you can enter is <i>99</i>.</p> <p>See <a href="#">Using the Job Search Agent</a>.</p>
<b>Max Jobs Returned from Search</b>	<p>Enter the maximum number of job postings that Candidate Gateway returns when an applicant performs a job search. Choose a value less than 1000 based on your organization's requirements for usability and performance.</p> <hr/> <p><b>Important!</b> Regardless of the value you enter here, the number of search results will not exceed any system-wide search results maximum for PeopleTools Search Framework and its underlying search engine.</p> <hr/>

<b>Field or Control</b>	<b>Description</b>
<b>Configure Multiple Job Posting Descriptions</b>	<p>Select to configure how to update the job posting description in the <a href="#">Posting Information Page</a>.</p> <p>Select <i>Yes</i> if you want to modify the posting information in a modal window with Rich Text Editor. Ideal if you have large number of posting descriptions. Select <i>No</i> if you want to modify the posting information directly on the same page. The default option is No.</p>

### My Job Openings Settings

<b>Field or Control</b>	<b>Description</b>
<b>My Job Openings Page Maximum Results</b>	<p>Enter the maximum number of job openings that Candidate Gateway returns when an applicant performs a job search. Choose a value based on your organization’s requirements for usability and performance.</p>
<b>My Association</b>	<p>Select a value representing your association with the job opening. Options are:</p> <p>Available options are:</p> <ul style="list-style-type: none"> <li>• Created by Me</li> <li>• Hiring Manager</li> <li>• Recruiter</li> <li>• Team Member</li> </ul>
<b>Job Opening Status</b>	Status of job opening.

### Recruiting Installation – Manage Jobs Page

Use the Recruiting Installation – Manage Jobs page (HRS\_MJ\_INST) to define the display setting for Applicants page within the Manage Job Openings Page.

Navigation:

**Set Up HCM > Install > Product Specific > Recruiting Installation > Manage Jobs**



This example illustrates the Recruiting Installation – Manage Jobs page.

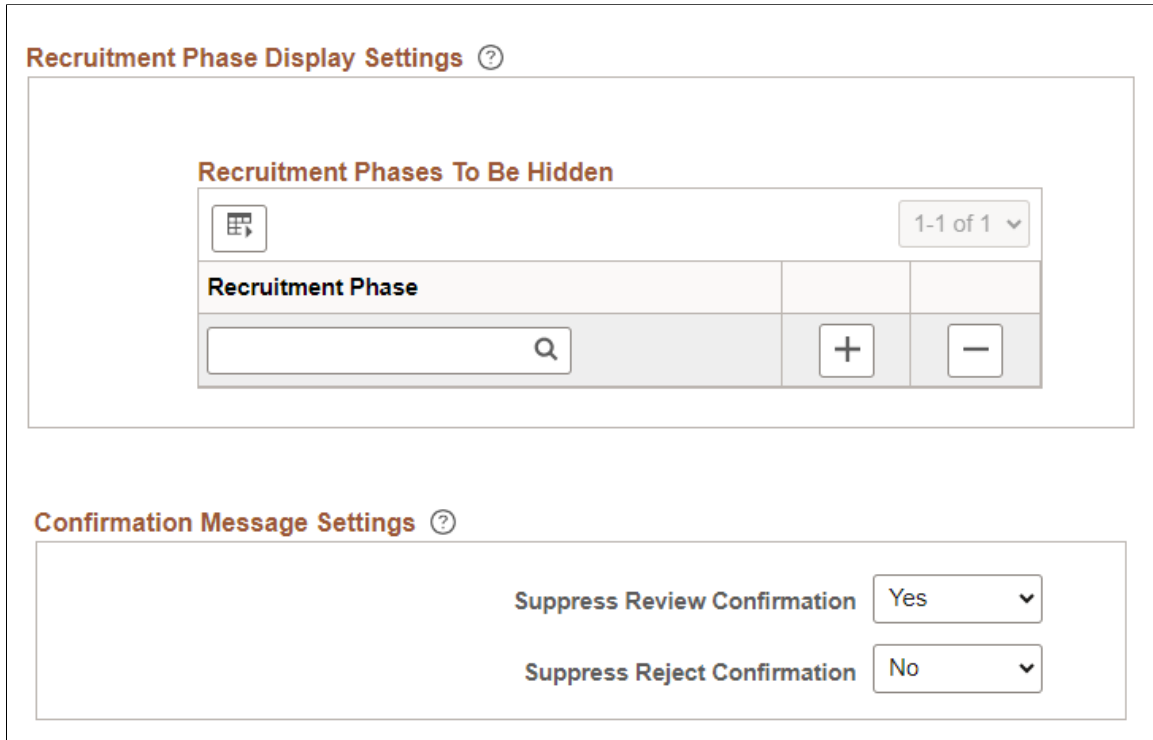

### Recruitment Phase Display Settings

<i>Field or Control</i>	<i>Description</i>
<b>Recruitment Phase</b>	<p>Select to hide the recruitment phase from the phase filter in the Applicants page. For more information, see <a href="#">Manage Job Opening Page: Applicants Tab</a>.</p> <hr/> <p><b>Note:</b> This setting is used to hide the display of the filters alone. This does not hide the actions available in the grid. For example, hiding the <i>Interview</i> phase hides the phase from the filter. However, the <i>Interview</i> action is available in the grid.</p>

### Confirmation Message Settings

<i>Field or Control</i>	<i>Description</i>
<b>Suppress Review Confirmation</b>	Select to enable or disable the display of confirmation message in the Applicants page when an applicant is marked as reviewed.
<b>Suppress Reject Confirmation</b>	Select to enable or disable the display of confirmation message in the Applicants page when an applicant is rejected.

For more information, see [Manage Job Opening Page: Applicants Tab](#).

## Recruiting Installation – Applicants Page

Use the Recruiting Installation – Applicants page (HRS\_INST\_APPLICANT) to define system-wide settings for applicants.

Navigation:

**Set Up HCM > Install > Product Specific > Recruiting Installation > Applicants**

This is the first of three examples illustrating the Recruiting Installation – Applicants page.

**Applicant Settings**

Verify Employee ID	<input type="text" value="Optional"/>	▼	
Verify Person of Interest	<input type="text" value="No"/>	▼	
Inactive State for Duplicates	<input type="text" value="030"/>	🔍	030 Inactive
Status Reason For Duplicates	<input type="text" value="010"/>	🔍	Merged Applicant
Allow Online Job Offers	<input type="text" value="Yes"/>	▼	<a href="#">Regulatory Regions</a>
Days Online Offer Valid	<input type="text" value="10"/>		
Administrator Evaluation Edit	<input type="text" value="Yes"/>	▼	
Require Reason Upon Manual Reject	<input type="text" value="No"/>	▼	
Display Interest Indicator	<input type="text" value="No"/>	▼	
Batch Action Threshold	<input type="text" value="3"/>		
Group Action Limit	<input type="text" value="100"/>		
Maximum Applicants in List	<input type="text" value="0"/>		

This is the second of three examples illustrating the Recruiting Installation – Applicants page.

**Job Opening Search Autosave and Result Control**

Enforce Search Save

Maximum Results When Forcing Save

**Apply Online** ?

Site ID

Email Address Required

Phone Required

Display Address

Address Required

Days Job Search Agent Active

Maximum Job Agents

Registration Agreement

**Application Report Options** ?

Never Print Separator Pages

This is the third of three examples illustrating the Recruiting Installation – Applicants page.

**My Applicants Settings**

My Applicants Page Maximum Results

Applicant Type

Applicant Status

**Gender Configuration ?**

Relabel Gender

\*New Label for Gender

*Note - The label change will not be applicable to Reports, Search index and Analytics.*

Display Pronoun to Recruitment Administrators

Display Pronoun to Recruiters and Managers

### Applicant Settings

<i>Field or Control</i>	<i>Description</i>
<b>Verify Employee ID</b>	<p>Select whether it is <i>Required</i> or <i>Optional</i> for a recruiter to search the HR database during the Prepare for Hire process to determine whether an applicant was a previous employee, contingent worker, or person of interest for the company. Such searches help prevent duplicate records for the applicant</p> <p>See <a href="#">Understanding Hiring Applicants</a>.</p>
<b>Verify Person of Interest</b>	<p>Select <i>Yes</i> if you want the system to search the HR database for an existing record when you add an external applicant to the system as a person of interest using the Add Person of Interest action. Such searches help prevent duplicate records for the applicant.</p> <p>Select <i>No</i> to let external applicants be added as Persons of Interest without first searching for an existing record.</p> <p>See <a href="#">Adding Persons of Interest</a></p>

<b>Field or Control</b>	<b>Description</b>
<b>Inactive State for Duplicates</b>	<p>Select the status that the system will assign to duplicate applicant records that are inactivated during the duplicate merge process. For example, if you merge three records, one record continues to be active, and the other two are assigned the status that you designate in this field.</p> <p>See <a href="#">Processing Duplicate Applicants</a></p>
<b>Status Reason For Duplicates</b>	<p>Select the reason to associate with the inactive state for duplicates during the duplicate merge process. For example, if you merge three records, one record continues to be active, and the other two are assigned the status reason that you designate in this field.</p> <p>To know more on how to define the status reason, see <a href="#">Recruiting Status and Reason Page</a></p>
<b>Allow Online Job Offers</b>	<p>Select <i>Yes</i> to enable online job offer functionality, including the ability to make offer letters and other attachments available in Candidate Gateway and the ability for applicants to accept or reject the offers in the same manner.</p> <p>To disallow online job offer functionality, select <i>No</i>.</p> <p>See <a href="#">Creating Job Offers</a></p>
<b>Regulatory Regions</b>	<p>Click this link, which is only available if the <b>Allow Online Job Offers</b> field value is <i>Yes</i>, to access the Online Job Offers - Select Regulatory Regions page, where you specify which regulatory regions use online job offer functionality.</p>
<b>Days Online Offer Valid</b>	<p>If the <b>Allow Online Job Offers</b> field value is <i>Yes</i>, enter the default number of days that an online job offer remains valid. Users can override this default within specific offers.</p>
<b>Administrator Evaluation Edit</b>	<p>Select <i>Yes</i> or <i>No</i> to indicate whether administrators are allowed to edit, delete, and send back interview evaluations.</p> <p>This setting applies only to interview evaluations, not to open-ended question evaluations.</p> <p>See <a href="#">Completing Interview Evaluations</a></p>

<b>Field or Control</b>	<b>Description</b>
<b>Require Reason Upon Manual Reject</b>	<p>Select <i>Yes</i> to force Talent Acquisition Manager users to supply a reason when rejecting an applicant using the Reject action. This setting does not apply to using the Edit Disposition action to reject an applicant.</p> <hr/> <p><b>Note:</b> If you activate this option, be sure to set up reasons for the <i>110 - Reject</i> disposition.</p> <hr/> <p>Select <i>No</i> to allow users to reject applicants without supplying a reason.</p>
<b>Display Interest Indicator</b>	<p>Select <i>Yes</i> to enable a widget that lets users assign applicants a one-star to three-star level of interest for an applicant in the context of a specific job. The interest indicator appears on the Manage Job Opening page, the Manage Application page, and the search results for the Search Applications page. It is also available as search criteria on the Search Applications page.</p> <p>The interest level for an applicant is specific to the job opening (or application without a job opening), but it is not specific to the user.</p>
<b>My Applicants Page Maximum Results</b>	<p>Enter the maximum number of applicants to be listed in the <a href="#">My Applicants Pagelet</a> on the Recruiting Home page. Choose a value that balances your usability needs and your performance requirements. The default value is 300.</p>
<b>Batch Action Threshold</b>	<p>Enter the number of notifications that will cause the Send Correspondence and Route Applicant actions to send the notifications using a background batch process. If the number of notifications generated by an action does not reach this threshold, the user remains on the action page while the notifications are sent. Setting a batch action threshold frees up users to continue with other tasks while the system processes high volumes of notifications.</p> <p>Enter <i>0</i> (the number zero) to disable batch processing for notifications.</p> <hr/> <p><b>Note:</b> The threshold refers to the number of notifications to be sent, not the number of applicants being processed. For example, if five applicants are selected for routing, and they are routed to five recipients, the transaction involves 25 notifications.</p> <hr/>

<b>Field or Control</b>	<b>Description</b>
<b>Group Action Limit</b>	<p>Enter the maximum number of rows that can be included when a user performs a group action.</p> <p>If a user attempts to perform a group action when too many rows are selected, the system displays a message informing the user of the limit and stating that only the allowed number of rows will be processed.</p> <p>If the user continues, the system processes the allowed number of rows, starting at the beginning of the list and following the grid sort order. Even if the user cancels, the system deselects all rows after the specified limit, and the user can review which rows will be processed before re-initiating the action with an allowable number of selected rows.</p> <p>The default limit is <i>100</i>. The minimum limit is <i>1</i>, and the maximum limit is <i>99999</i>.</p> <p>See <a href="#">Understanding Actions for Managing Applicants</a>.</p>
<b>Maximum Applicants in List</b>	<p>Enter the maximum number of applicants to be displayed when an Applicant List is opened. Use the Find Applicant search functionality to search for other applicants. The Applicant List page displays a message when the number of applicants exceeds the number of maximum applicants set in this field.</p>

## Job Opening Search Autosave and Result Control

<b>Field or Control</b>	<b>Description</b>
<b>Enforce Search Save</b>	<p>Select <i>Yes</i> or <i>No</i> to indicate whether you want the system to force users who are searching for applicants to save their search criteria when a specific job opening is part of the criteria.</p> <p>The system forces the save by displaying the Save Search page after the user initiates the search but before the search results appear. The user cannot continue to the results without saving the criteria. The user can, however, cancel to return to the search page without executing the search.</p> <p>After a user performs a forced save, the search results appear. Above the search results, the system displays information about saving the search results using the Save for Compliance button. Although the message reminds the user to save the results, the user is not forced to do so.</p> <p>Saved searches that are created as a result of this setting retain their association with the job opening. This association means that the searches appear in the Searches grid on the <a href="#">Manage Job Opening Page: Activity &amp; Attachments Tab</a> and in the Saved Searches &amp; Automatches grid on the <a href="#">Manage Job Opening Page: Applicant Search Tab</a>.</p> <p>This functionality supports requirements of the United States Office of Federal Contract Compliance Programs (OFCCP)</p> <p>See <a href="#">Understanding Saved Searches</a>.</p>
<b>Maximum Results When Forcing Save</b>	<p>Enter the maximum number of rows in the search results when a user searches for applicants using a PeopleTools Search Framework-based search. This setting applies only if you select <i>Yes</i> in the <b>Enforce Search Save</b> field.</p> <hr/> <p><b>Important!</b> Regardless of the value you enter here, the number of search results will not exceed any system-wide search results maximum for PeopleTools Search Framework and its underlying search engine.</p> <hr/>

### Apply Online

Use this group box to define implementation defaults for PeopleSoft Candidate Gateway.



<b>Field or Control</b>	<b>Description</b>
<b>Site ID</b>	<p>Choose which site is shown when you use the delivered menu navigation to access Candidate Gateway pages. Changing this setting enables you to access and test different site definitions.</p> <p>A single site definition is associated with the navigation paths for internal applicants (<b>Self Service &gt; Recruiting &gt; Careers</b>) and external applicants (select <b>Careers</b> under the main menu).</p> <p>Because jobs can be posted to different sites based on the recruitment source definition, changing this setting can also change the job postings that are available on the test sites.</p> <p>See “Setting Up Sites” (PeopleSoft Candidate Gateway).</p>
<b>Email Address Required</b>	<p>Select <i>Yes</i> to force applicants to provide an email address when registering for Candidate Gateway. Already-registered applicants who have not already supplied an email address will be forced to provide one the next time they sign in.</p> <p>Although you can select <i>No</i> if you do not want to require email addresses, keep in mind that applicant email addresses are required for user ID and password recovery as well as for sending email notifications.</p> <hr/> <p><b>Important!</b> The only way to be sure that user ID and password recovery functionality is available to all Candidate Gateway users is to set this field to <i>Yes</i> so that an email address is required.</p> <hr/>
<b>Phone Required</b>	<p>Select <i>Yes</i> to force applicants to provide a phone number when registering for Candidate Gateway. Already-registered applicants who have not already supplied a phone number will be forced to provide one the next time they sign in.</p>
<b>Display Address</b>	<p>Select <i>Yes</i> to display address fields on the Candidate Gateway registration page.</p> <p>If the address fields are not shown on the registration page, applicants can still enter an address by updating their account information. However, this option is less obvious to applicant.</p> <p>Already-registered applicants who have not supplied an address will be prompted to provide one the next time they sign in.</p>

<b>Field or Control</b>	<b>Description</b>
<b>Address Required</b>	<p>Select <i>Yes</i> to force applicants to provide an address when registering for Candidate Gateway. Already-registered applicants who have not supplied an address will be forced to provide one the next time they sign in.</p> <p>You can select <i>Yes</i> only if you already selected <i>Yes</i> in the <b>Display Address field</b>.</p> <p>Registration is your only opportunity to require applicants to supply an address, but even if an address is not required, external applicants can always update their address information on the My Account Information page.</p>
<b>Days Job Search Agent Active</b>	<p>Enter the number of days that an applicant's job search agent is kept in the database. If a job search agent is modified, the retention period resets.</p> <p>The maximum number of days that an applicant's job search agent can stay active is 999. This setting is used by the Job Agent process to determine whether applicants' saved job agents are out of date and should be deleted. If you do not enter a value, the system keeps job agents in the database indefinitely.</p> <p>If job agents expire, applicants can see the expiration date on the My Saved Searches page in Candidate Gateway. The expiration date is also given in the email notifications that the job agent process sends to the applicant.</p> <p>See <a href="#">Using the Job Search Agent</a></p>
<b>Maximum Job Agents</b>	<p>Enter the maximum number of job agents that an applicant can have.</p> <p>The default is five.</p>

<b>Field or Control</b>	<b>Description</b>
<p><b>Registration Agreement</b></p>	<p>Select this check box to require external applicants to agree to your registration terms. The text of the registration terms comes from text catalog entry <i>HRAM_CETRMAGRE_03</i>.</p> <p>If this check box is selected, applicants must indicate agreement at these times:</p> <ul style="list-style-type: none"> <li>• When the applicant first registers for Candidate Gateway.</li> <li>• During registration updates.</li> </ul> <p>Registration updates occur when applicants attempt to sign in after you change registration requirements (such as password requirements or required fields). The Registration Update page always requires applicants to agree to registration terms, even if they previously agreed to the same terms during their initial registration or a previous registration update.</p> <p>Activating registration terms or updating the text of your terms is a change to your registration requirements. Therefore, applicants are prompted to update their registration the first time they sign in after these changes are made.</p> <hr/> <p><b>Important!</b> The effective date for text catalog entries does not include a time stamp. Therefore, when you change your terms and conditions, always enter the changes in a future-dated row. This is necessary so that applicants who signed in on the date you made the change will be prompted to agree to the new terms.</p> <hr/> <p>For more information, see “Registering Online and Signing In” (PeopleSoft Candidate Gateway) and “Using Fluid Candidate Gateway to Register and Sign In” (PeopleSoft Candidate Gateway).</p>

### Application Report Options

---

**Note:** This section is visible only if you use PeopleTools 8.55 or higher. With earlier versions of PeopleTools, users cannot print attachments as part of the Application Details report.

---

<b><i>Field or Control</i></b>	<b><i>Description</i></b>
<b>Never Print Separator Pages</b>	Select this check box to prevent users from including separator pages before included attachments in the Application Details report. If this check box is not selected, end users can choose whether to print separator pages.  See <a href="#">Printing Application Details</a> .

## My Applicant Settings

Use this group box to define settings for the My Applicants page.

<b><i>Field or Control</i></b>	<b><i>Description</i></b>
<b>My Applicants Page Maximum Results</b>	Enter the maximum number of applicants to be listed in the My Applicants page on the Recruiting Home page. The default value is 300.
<b>Applicant Type</b>	Select the applicant type. The available options are <b>Employee</b> , <b>External Applicant</b> , and <b>Non-Employee</b> .
<b>Applicant Status</b>	Select the applicant status. The available options are <b>010 Active</b> , <b>020 Hired</b> , <b>030 Inactive</b> , and <b>040 Queued</b> .

## Gender Configuration

Use this group box to configure the gender-related fields in the Talent Acquisition Manager pages.

<b><i>Field or Control</i></b>	<b><i>Description</i></b>
<b>Relabel Gender</b>	Select this check box to change the label of the Gender field in the Talent Acquisition Manager pages, like Create Applicant, Search Applicant, Job Opening, Set Up pages etc.
<b>New Label for Gender</b>	Enter the new label for Gender. The default value is Current Sex.
<b>Display Pronoun to Recruitment Administrators</b>	Use this check box to display the pronoun of the internal applicants to the Recruitment Administrators in the <b>Manage Applicant</b> page ( <b>Applicant Data</b> tab – <b>Eligibility &amp; Identity</b> section).

<b>Field or Control</b>	<b>Description</b>
<b>Display Pronoun to Recruiters and Managers</b>	Use this check box to display the pronoun of the internal applicants to the Recruiters and Managers in the <b>Manage Applicant</b> ( <b>Applicant Data</b> tab – <b>Eligibility &amp; Identity</b> section) and <b>Manage Application</b> page.

**Note:** **Manage Applicant** and **Manage Application** pages display the pronoun of internal applicants, if it is set up in the Gender Details page and they have logged in to Candidate Gateway after the pronoun is enabled in the settings. To know more on how to enter the gender details, see “Setting Up Gender Details” (Application Fundamentals).

PeopleSoft Talent Acquisition Manager uses the same regulatory region security as PeopleSoft Human Resources. Recruitment Administrators, Recruiters, and Managers see the pronoun based on the regulatory region security. For more information, refer “Setting Up Regulatory Regions” (Application Fundamentals), “Setting Up Security for Local Functionality” (Application Fundamentals), and *PeopleTools: Administering User Profiles*, Specifying User Profile Attributes.

## Online Job Offers – Select Regulatory Regions Page

Use the Online Job Offers - Select Regulatory Regions page (HRS\_ONL\_OFR\_RG\_SEC) to select the regulatory regions where you allow online job offers.

Navigation:

Click the **Regulatory Regions** link on the Recruiting Installation - Applicants page.

This example illustrates the Online Job Offers - Select Regulatory Regions page.

### Online Job Offers - Select Regulatory Regions

**Regulatory Regions**

☰

 ⏪ ⏩ 1-48 of 48 ⏴ ⏵

Include	Regulatory Region
<input type="checkbox"/>	Argentina
<input type="checkbox"/>	Australia
<input type="checkbox"/>	Belgium
<input type="checkbox"/>	Brazil
<input type="checkbox"/>	Canada
<input type="checkbox"/>	Canada - Alberta
<input type="checkbox"/>	Canada - British Columbia
<input type="checkbox"/>	Canada - Manitoba

Select All
Deselect All

OK
Cancel

<i>Field or Control</i>	<i>Description</i>
<b>Include</b>	<p>Select this check box for any regulatory regions where you want to allow online job offers.</p> <p>The system compares the regulatory region for the job opening with the settings on this page to determine when to enable online job offers.</p>

## Recruiting Installation – Last Assigned IDs Page

Use the Recruiting Installation - Last Assigned IDs page (HRS\_INST\_CNTRS) to specify starting numbers for system-assigned identifiers.

**Note:** These should be set to a number that does not overlap with existing values in the database or you will get duplicate value errors.

Navigation:

**Set Up HCM > Install > Product Specific > Recruiting Installation > Last Assigned IDs**

This image is the first of three examples illustrating the Recruiting Installation - Last Assigned IDs page.

General	Jobs	Applicants	Last Assigned IDs
<b>Job Opening Counters</b>			
Job Opening ID	<input type="text" value="303666"/>	Recruiting Location	<input type="text" value="1258"/>
JO Screening Summary ID	<input type="text" value="1612"/>	Screening Template ID	<input type="text" value="2005"/>
Screening ID	<input type="text" value="1013"/>	Recruitment Template ID	<input type="text" value="2019"/>
Job Opening Posting ID	<input type="text" value="1002"/>	Job Opening Template ID	<input type="text" value="1013"/>
Team ID	<input type="text" value="1004"/>	Job Creation Process ID	<input type="text" value="1000"/>
Recruiting Process ID	<input type="text" value="1001"/>	Flexible Process Template ID	<input type="text" value="1001"/>
Flexible Template Group ID	<input type="text" value="1001"/>		
<b>Applicant Counters</b>			
Applicant ID	<input type="text" value="500313"/>	Last Resume ID Used	<input type="text" value="1432"/>
Last Page Layout ID	<input type="text" value="102"/>	Correspondence ID	<input type="text" value="1004"/>
Last Resume Number	<input type="text" value="1000"/>	Resume Template ID	<input type="text" value="2023"/>
Duplicate Process ID	<input type="text" value="1"/>		

This image is the second of three examples illustrating the Recruiting Installation - Last Assigned IDs page.

**Recruitment Counters**

Answer ID <input style="width: 80%;" type="text" value="4006"/>	Offer ID <input style="width: 80%;" type="text" value="1170"/>
Works Council Decision ID <input style="width: 80%;" type="text" value="1002"/>	Offer Letter ID <input style="width: 80%;" type="text" value="1000"/>
Checklist ID <input style="width: 80%;" type="text" value="1024"/>	Question ID <input style="width: 80%;" type="text" value="4011"/>
Evaluation ID <input style="width: 80%;" type="text" value="1023"/>	Question Set ID <input style="width: 80%;" type="text" value="1027"/>
Interview Category ID <input style="width: 80%;" type="text" value="1001"/>	Recruitment ID <input style="width: 80%;" type="text" value="3246"/>
Interview Rating <input style="width: 80%;" type="text" value="1000"/>	Recruitment Letter ID <input style="width: 80%;" type="text" value="1019"/>
Interview ID <input style="width: 80%;" type="text" value="1176"/>	Recruitment Interview ID <input style="width: 80%;" type="text" value="1065"/>
Interview Letter ID <input style="width: 80%;" type="text" value="1014"/>	Route ID <input style="width: 80%;" type="text" value="1085"/>
Venue ID <input style="width: 80%;" type="text" value="5"/>	

**Correspondence Counters**

List ID <input style="width: 80%;" type="text" value="1029"/>	Package ID <input style="width: 80%;" type="text" value="1000"/>
Notes ID <input style="width: 80%;" type="text" value="1179"/>	Contact Method <input style="width: 80%;" type="text" value="1000"/>
Correspondence ID <input style="width: 80%;" type="text" value="1009"/>	Token ID <input style="width: 80%;" type="text" value="1017"/>
Parameter ID <input style="width: 80%;" type="text" value="1000"/>	

This image is the third of three examples illustrating the Recruiting Installation - Last Assigned IDs page.

**Vendor Related Counters**

Integration ID <input style="width: 80%;" type="text"/>	Transaction Group ID <input style="width: 80%;" type="text" value="3"/>
Vendor-Transaction ID <input style="width: 80%;" type="text"/>	Vendor ID <input style="width: 80%;" type="text"/>
Source ID <input style="width: 80%;" type="text" value="44"/>	SubSource ID <input style="width: 80%;" type="text" value="12"/>
Log ID <input style="width: 80%;" type="text"/>	Extractor Log ID <input style="width: 80%;" type="text" value="63"/>
Notification Log ID <input style="width: 80%;" type="text"/>	Resolution Log ID <input style="width: 80%;" type="text" value="97"/>
Data mapping ID <input style="width: 80%;" type="text"/>	Assigned Mapping ID <input style="width: 80%;" type="text" value="3"/>
Resume Management ID <input style="width: 80%;" type="text" value="726"/>	Resume ID <input style="width: 80%;" type="text"/>
Resume Load ID <input style="width: 80%;" type="text" value="1"/>	Email Setup ID <input style="width: 80%;" type="text" value="2"/>
Screening ID <input style="width: 80%;" type="text" value="2"/>	Key ID <input style="width: 80%;" type="text" value="1"/>
XSLT ID <input style="width: 80%;" type="text"/>	XML ID <input style="width: 80%;" type="text" value="63"/>
External Posting ID <input style="width: 80%;" type="text" value="5"/>	Category ID <input style="width: 80%;" type="text" value="11"/>
Contact ID <input style="width: 80%;" type="text" value="5"/>	Pre-Employment Person ID <input style="width: 80%;" type="text"/>
Log Sequence <input style="width: 80%;" type="text" value="1089"/>	

**Other Counters**

Letter ID <input style="width: 80%;" type="text" value="1034"/>	Search ID <input style="width: 80%;" type="text" value="1041"/>
Prepare For Hire ID <input style="width: 80%;" type="text" value="1097"/>	



Identification numbers are system-assigned values that you use to track specific records within the database. These values typically do not require manual assignment unless data conversion has occurred. The system uses these numbers to identify the point at which the system will begin assigning identification numbers for various recruitment records. The system automatically increases the number by one when it assigns a new number and updates this page with the new number.

<b><i>Field or Control</i></b>	<b><i>Description</i></b>
<b>Fix Counters</b>	Click to synchronize the counter with the actual values in the recruiting database. The system searches for the maximum value being used and resets the counter to that value. This prevents duplicate ID errors and also sets the counters at values that are appropriate to your own implementation (rather than using the delivered values, which reflect the sample data provided by Oracle).



## Chapter 3

# Setting Up Profile Integration

---

## Understanding Profile Architecture

Profiles are widely used by organizations to describe the attributes of jobs or individuals. Typically, profiles summarize the competencies, qualifications, and skills of a job or a person. The Manage Profiles business process in PeopleSoft Human Resources provides a framework for developing and managing profiles that meet your industry or organizational requirements.

During the recruitment process, PeopleSoft Talent Acquisition Manager uses profiles to capture job requirements and applicant qualifications.

These are some of the architectural elements for profiles that are relevant to Talent Acquisition Manager:

<b>Term</b>	<b>Definition</b>
Profile	An organized collection of data that represents attributes of a person or of a business object such as a job code.
Content Type	A category of information in a profile. Delivered content types that support recruiting processes include competencies, languages, memberships, degrees, licenses & certificates, and so forth.
Content Item	A specific attribute that is associated with a particular content type. For example, for the content type <i>Competencies</i> , content items are specific competencies such as analytical thinking or the ability to prioritize tasks.
Profile Type	<p>Profile types define the structure of your profiles. A profile type includes content types, but not content items. That is, a particular profile type might include content types such as competencies and memberships, but it does not reference particular competencies or particular memberships.</p> <p>The profile type also defines whether the profile is linked to person IDs to create person profiles, or linked to business entities, such as job code or positions, to create non-person profiles.</p> <p>Four profile types are delivered as system data. Use the CLUSTER, ROLE, and JOB profile types to create non-person profiles, and the PERSON profile type to create profiles that describe your employees.</p>

## Related Links

[Understanding Profile Integration for Job Openings](#)

[Understanding Profile Information in Job Applications](#)

---

## Choosing the Primary Person Profile Type for Recruiting

To set up the primary person profile type for recruiting, use the Assign Default Profile Types (JPM\_DFLT\_JP\_TYPES) component.

### Page Used to Set Up the Primary Person Profile for Recruiting

<i>Page Name</i>	<i>Definition Name</i>	<i>Usage</i>
<a href="#">Assign Profile Type Defaults Page</a>	JPM_DFLT_JP_TYPES	Identify the primary person profile type for the system. This person profile type provides the structure for applicant and job opening qualifications in Talent Acquisition Manager.

## Understanding the Primary Person Profile Types

PeopleSoft Talent Acquisition Manager uses profiles to capture job requirements and applicant qualifications. The content types that are available for use in job openings and in applications are those that belong to the system's primary person profile type, as defined on the Assign Profile Defaults page. The delivered primary person profile type is *PERSON*.

Using the primary person profile type ensures that applicant profile data is stored in a format that is compatible with employee profile data and that profile data can follow those applicants who become employees. When your organization analyzes requirements for defining your primary person profile type, be sure that recruiting requirements are considered.

All content types in the primary person profile type are included on the [Application Details Page](#), where you enter applicant qualifications. On this page, the fields and layout for content types and items are determined solely by the profile configuration as defined using the Manage Profiles business process; there is no recruiting-specific formatting or configuration involved.

Additional recruiting-specific configuration enables you to use choose which content items to use in job openings, during screening, and for the online application form in Candidate Gateway:

- The Content Section Configuration page controls which content types are available to use in job openings and for screening.

This page also controls the presentation of profile data in job openings and in Candidate Gateway.

- Job opening templates control which of the content types appear on the Job Opening page.
- Resume templates control which of the content types appear to applicants who apply online using Candidate Gateway.

Resume templates can include any content type from the primary person profile type; selection is not limited based on settings on the Content Section Configuration page.

## Related Links

[Configuring Profiles for Recruiting](#)

[Setting Up Job Opening Templates](#)

[Setting Up Resume Templates](#)

## Assign Profile Type Defaults Page

Use the Assign Profile Type Defaults page (JPM\_DFLT\_JP\_TYPES) to identify the primary person profile type for the system.

This person profile type provides the structure for applicant and job opening qualifications in Talent Acquisition Manager.

Navigation:

**Set Up HCM > Product Related > Profile Management > Profiles > Assign Default Profile Types > Assign Profile Type Defaults**

This example illustrates the Assign Profile Type Defaults page.

<b>Field or Control</b>	<b>Description</b>
<b>Primary Person Profile Type</b>	<p>Enter the primary person profile type. This is a system-wide setting that is used throughout PeopleSoft Human Resources. In Talent Acquisition Manager, the primary person profile type determines the content types that are available for use in job openings and in applications.</p> <p>The delivered primary person profile type is <i>PERSON</i>.</p> <p>See “Assign Profile Type Defaults Page” (PeopleSoft Human Resources Manage Profiles).</p>
<b>Primary NonPerson Profile Type</b>	<p>Talent Acquisition Manager does not use the system's primary nonperson profile type.</p>

## Configuring Profiles for Recruiting

To configure profiles for recruiting, use the Content Section Configuration (HRS\_JPM\_SECT\_CFG) component.

### Page Used to Configure Profiles for Recruiting Use

<i>Page Name</i>	<i>Definition Name</i>	<i>Usage</i>
<u>Content Section Configuration – &lt;Content Type&gt; Page</u>	HRS_JPM_SECT_CFG	Configure profile content types for use in Talent Acquisition Manager.

### Understanding Content Type Configuration for Recruiting

Profiles types that you create using PeopleSoft Human Resources are used by multiple PeopleSoft applications. To cater to all applications, the primary person profile type may contain content types that you do not want to use for recruiting. Also, the content types that you do use often include properties (fields) that are not relevant to the recruiting process.

To select which content types to use, and how to use specific content type properties, use the Content Section Configuration page to enter recruiting-specific configuration options for each content type in the primary person profile type.

#### Data Integrity Considerations

Changes to the content type definition in the Manage Profiles module can cause data integrity issues in Talent Acquisition Manager. Be sure to finalize your profile and content type configuration before performing the additional profile configuration for Talent Acquisition Manager.

#### Preventing Duplicates After Changing the Primary Person Profile Type

If you change the primary person profile type, the Content Section Configuration record will initially store duplicate entries for content types: one entry is associated with the previous primary person profile type, and one is associated with the new primary person profile type.

To correct this situation, access every Content Section Configuration entry and save it. (It is not necessary to make changes before saving.) The save process cleans up the duplicate records.

### Content Section Configuration – <Content Type> Page

Use the Content Section Configuration – <Content Type> page (HRS\_JPM\_SECT\_CFG) to configure profile content types for use in Talent Acquisition Manager.

The search dialog for this page enables you to access content types from the primary person profile type. You cannot add additional content types using this page.

---

**Note:** The page title changes according to the content type that you are configuring.

---

Navigation:

**Set Up HCM > Product Related > Recruiting > Templates > Content Section Configuration > <Content Type>**

This example illustrates the Content Section Configuration – <Content Type> Page .

### Licenses and Certifications

---

Status Date    Applicant may add items

Field Name	Label Text	Required	Summary	Detail	Use in Screening	Default
EFFDT	Issue Date	<input checked="" type="checkbox"/>	<input checked="" type="checkbox"/>	<input checked="" type="checkbox"/>		
JPM_CAT_ITEM_ID	License	<input checked="" type="checkbox"/>	<input checked="" type="checkbox"/>	<input checked="" type="checkbox"/>	<input checked="" type="checkbox"/>	
COUNTRY	Country	<input type="checkbox"/>	<input type="checkbox"/>	<input checked="" type="checkbox"/>		
STATE	State	<input type="checkbox"/>	<input type="checkbox"/>	<input checked="" type="checkbox"/>		
JPM_YN_1	Renewal Required	<input type="checkbox"/>	<input type="checkbox"/>	<input checked="" type="checkbox"/>	<input type="checkbox"/>	
JPM_YN_2	Renewal In Progress	<input type="checkbox"/>	<input type="checkbox"/>	<input checked="" type="checkbox"/>	<input type="checkbox"/>	
JPM_YN_3	License Verified	<input type="checkbox"/>	<input type="checkbox"/>	<input checked="" type="checkbox"/>	<input type="checkbox"/>	
JPM_DATE_3	Expiration Date	<input type="checkbox"/>	<input type="checkbox"/>	<input checked="" type="checkbox"/>		
JPM_TEXT254_2	License/Certification Number	<input type="checkbox"/>	<input type="checkbox"/>	<input checked="" type="checkbox"/>		
JPM_TEXT254_4	Issued By	<input type="checkbox"/>	<input type="checkbox"/>	<input checked="" type="checkbox"/>		

<b>Field or Control</b>	<b>Description</b>
<b>Status Date</b>	The default value is the date on which the content type was added. This field is informational only and does not function as an effective date. Modifying the date (even to a future date) does not affect whether the content type is available for resume templates or job opening templates.

<b>Field or Control</b>	<b>Description</b>
<p><b>Applicant may add items</b></p>	<p>Select this check box to indicate that Candidate Gateway will allow applicants to add content items to their applications. Deselect this check box if applicants can modify the details for the content items that are part of the job opening, but not add new ones.</p> <p>For example, you may want applicants to provide proficiency ratings for specific competencies, but you do not want applicants to add additional competencies that you do not consider relevant to the recruiting process. Because this check box is selected for the Competencies content type, the competencies that you associate with the job opening appear in the Candidate Gateway application form, and applicants can rate themselves for those competencies, but they cannot add any additional competencies.</p> <hr/> <p><b>Note:</b> When the system loads content items from a job opening into the Candidate Gateway application form, it loads only items that are visible to employees. For example, if a Job Opening has four competencies, and the first two have the evaluation type <i>Self</i> and the last two have the evaluation type <i>Official</i>, only the first two items appear in the Candidate Gateway online application form.</p> <hr/> <p>If this check box is deselected, the Summary check box is automatically selected and greyed out for all required fields, and the detail check box column is hidden for all fields. You can select the Summary check box for any additional properties that the applicant needs to supply. Because the applicant cannot add content items, the system does not provide the applicant with access to the corresponding detail page, and the only opportunity for data entry is within the summary grid.</p> <p>If this check box is deselected, this content type is included when you use the Copy Limited Items from Job Opening button on the Application Data page. That button copies content items from job openings into job applications.</p> <p>For example, the delivered content type configuration for competencies prevents applicants from adding competencies to their applications. The assumption is that you want to rate applicants on specific job-related competencies that you have defined in the job opening. To facilitate data entry on the Applicant Data page, and to ensure that you rate applicants on the correct set of competencies, you click the Copy Limited Items from Job Opening button. If there are any competencies that are associated with the job openings listed in the application, the system copies those competencies to the application so that you can enter applicant-specific ratings.</p>

## Properties

This grid lists all the properties (fields) for the content type. Content type properties are defined using the Manage Profiles module in PeopleSoft Human Resources.



<b>Field or Control</b>	<b>Description</b>
<b>Field Name and Label Text</b>	These fields identify a specific field that is part of the content type definition. For example, the content type Competencies, which you use for applicant competency ratings, includes fields such as Rating Model and Proficiency.
<b>Required</b>	<p>If this check box is selected, the property is required. Otherwise, it is optional. For example, in the Degrees content type, the degree itself is a required property, while additional properties such as the school code are optional.</p> <p>This check box is read-only; this setting comes from the content type definition in the Manage Profiles module.</p>
<b>Summary and Details</b>	<p>Select the Summary check box to include the property as a column in the grid that represents this content type.</p> <p>Select the Details check box to include the property on the detail page for this content type. This check box is not available when the <b>Applicant may add items</b> check box is deselected.</p> <p>These settings affects the grids and detail pages on the Job Opening page and on the job application in Candidate Gateway. They do <i>not</i> affect the grids on the Application Data page in Talent Acquisition Manager.</p> <hr/> <p><b>Note:</b> The best practice is to limit the number of fields that are marked as summary fields. Too many summary fields results in excessively wide grids. This is a usability issue for all users, but particularly for Candidate Gateway applicants, who are untrained casual users.</p> <hr/>

<b>Field or Control</b>	<b>Description</b>
<b>Use In Screening</b>	<p>Select this check box to make the field available for screening. Fields where this check box is selected are included in the criteria list on the Job Opening - Screening Criteria page, where you choose which of the available criteria to use in a specific screening level. Each selected item is treated as a separate screening item, and users must set up screening scoring bearing in mind the interrelationships between items.</p> <p>For example, the delivered configuration for the Competencies content type has only one field that is available for screening: the proficiency field. When you add a competency to a job opening, you will enter data such as the competency name, rating type, and the rating. But when you configure the screening criteria for the job opening, the rating is the only competency-related information that is listed in the grid where you select screening criteria. (Because the rating is associated with a particular competency, rating model, and evaluation type, the screening process automatically looks for a rating for the associated competency, rating model, and evaluation type).</p> <p>If you were to change the configuration for competencies so that the competency name was the only field used in screening, then the screening process would simply check that the applicant's application lists the competency, regardless of the applicant's rating.</p> <p>Only certain fields are available for selection, including the content item ID (JPM_CAT_ITEM_ID for regular content types and JPM_ADHOC_DESCR for ad hoc content types), rating-related fields (JPM_RATING1 through JPM_RATING3), and yes/no indicators (JPM_YN_1 through JPM_YN_5).</p>
<b>Default</b>	Displays the default value for the property.

## Setting Up Profile Integration for Job Openings

To set up profile integration for job openings, use the Recruiting Installation (HRS\_INST) and Direct Reports Interface (HR\_DR\_UI\_CFG) components.

## Pages Used to Set Up Profile Integration for Job Openings

<i>Page Name</i>	<i>Definition Name</i>	<i>Usage</i>
<u>Recruiting Installation - General Page</u>	HRS_INST	Activate profile integration for job openings, and set up other system-wide recruiting settings. The option to activate person profile integration is available only after nonperson profile integration is activated.
“Direct Reports Configuration Page” (Application Fundamentals)	HR_DR_UI_CFG_1	Configure direct reports for the HRS_JOB_OPENING component.

## Understanding Setup for Profile Integration for Job Openings

This overview describes certain setup tasks for job opening profile integration.

### Integration Activation

When creating job openings, you can automatically populate the profile-based job qualifications with content items from selected profiles. For example, when replacing a key employee, you can copy attributes such as competencies and languages from the employee's profile into the job opening. Similarly, you can pull requirements from a job profile. You can even combine requirement sources by selecting up to three profiles from which to load requirements.

Use the Recruiting Installation - General page to activate profile integration for job openings and to choose whether to allow the use of person profiles in addition to non-person profiles.

Expanded profile integration enables the system to identify additional job profiles to load based on the job code, position number, job family, or salary grade of the job opening. If you activate this option, you choose which job opening field the system uses when identifying profiles to load. The setting for this option is in the recruitment template and can therefore vary depending on the job opening.

### Person Profile Security for Job Openings

If you use full profile integration, including integration with person profiles, users who are creating job openings can select person profiles whose content types are to be copied into the job opening. This ability is dependent on the user's security settings.

The system applies standard row-level security to ensure that users don't select profiles for employees that they are not authorized to view.

Users with the *Profile Mgmt Manager* role in their User Profile are authorized to view profiles for themselves and for their direct reports. To support this authorization, you must configure direct report access for the job opening component (HRS\_JOB\_OPENING)

---

**Important!** The direct report configuration for the HRS\_JOB\_OPENING component must exactly match the configuration for the JPM\_PERS\_PTSEL\_MGR component, as direct reports processing for profiles within the job opening component must mirror that of the manager self-service for person profiles.

---



## Chapter 4

# Setting Up Recruiting Statuses

---

## Understanding Recruiting Statuses

This topic provides overviews of:

- Recruiting status areas.
- Recruiting status setup

## Recruiting Status Areas

Recruiting statuses help a recruiter identify the circumstances of an applicant and job opening.

### The Six Status Areas

PeopleSoft Talent Acquisition Manager has six areas (known as recruitment areas) in which statuses are tracked:

1. Job Openings: helps identify where to focus efforts regarding a job opening.

For example, the job opening status can indicate whether a job opening is *Pending Approval*, *Open*, or *Filled/Closed*.

2. Applicants: helps identify who to act on, and what actions to take.

For example, the applicant status can indicate whether the applicant is *Active*, *Inactive*, or *Hired*.

3. Recruitment Summary: indicates an applicant's overall status with regards to a particular job opening.

For example, the recruitment summary status, or *disposition*, can indicate that an applicant has *Applied*, been *Reviewed*, been *Screened*, been *Interviewed*, received an *Offer*, or been *Hired* or *Rejected*.

Although the disposition is specific to a single job opening, applicants can also apply without identifying any job openings. The "no job selected" application also has a disposition.

---

**Important!** On recruiting pages, the status in this area is called the applicant's *disposition*.

---

4. Route: indicates the options for further steps to take for an applicant after screening or other preliminary assessment.
5. Interview: identifies the progress of an applicant within the interview stage and the options for further steps to take for the applicant.
6. Offer: identifies the progress of an applicant within the offer stage.

Status codes within the recruiting areas provide a convenient way to assign consistent business rules to your recruiting activities. When you define status codes, you can also define *status change effects* so that a status change in one recruitment area can affect the status in another recruiting area. This cascading effect relieves you of the responsibility for managing some of your recruiting processes.

For example, when you hire an applicant into a job opening, you can set the status of the applicant to *Hired*, the status of the job opening to *Filled/Closed*, the dispositions of all other applicants for that job opening to *Reject - Another Applicant Was Hired*, and the hired applicant's disposition with regards to any other job openings to *Reject - Selected for Other Position*.

---

**Note:** Although the Route, Interview, and Offer status areas might seem to be sub-statuses for the *Route*, *Interview*, and *Offer* dispositions, it is important to understand that these are separate status areas. Any relationship between them and the applicant's disposition is a result of status change effects.

---

## Dispositions and Phases

Dispositions (the statuses in the Recruitment Summary area) track the progress of an applicant through the entire recruiting process. Non-draft dispositions are associated with predefined phases. On the Manage Job Opening page: Applicants tab, you can filter the list of applicants based on these phases.

The predefined phases are, in order:

1. Applied
2. Reviewed
3. Screen
4. Route
5. Interview
6. Offer
7. Hire
8. Hold
9. Reject

## The Route and Interview Status Areas

The Route and Interview status areas serve a slightly different purpose than the other status areas.

For example, consider the delivered statuses for the Interview area: *Interview*, *Make Offer*, *Hold*, *Reject*, *Withdrawn*, and *Withdrawn Application*. These do not suggest the stages of the interview process (which might be more like scheduled, cancelled, and complete). Rather, these statuses indicate the beginning of the process (*Interview*) and then the possible next steps that you might want to take when the interview takes place.

When managing an applicant's interview, the interview statuses are used in two ways. First, the statuses are available in the interview evaluation form, where interviewers select a status to indicate what action they recommend. Recommending a status does not update the status, it simply provides feedback to the recruiter who eventually does update the status. Second, the statuses are available as choices when the recruiter selects a final recommendation after all interviews are complete. When the recruiter selects a

final recommendation, status change effects update the applicant's disposition accordingly. For example, if the final recommendation (and thus the final interview status) for the applicant is *Reject*, and if you use the delivered status change effects, the system updates the applicant's disposition to *Reject*.

The Route status area works the same way. The delivered statuses are *Routed*, *Invite for Interview*, *Hold*, *Reject*, *Withdrawn*, and *Withdrawn Application*. The recruiter sends out a request for routing recommendations, the recipients of that request recommend one of the statuses, the recruiter selects a final routing status, and status change processing in turn updates the applicant's disposition.

## Recruiting Status Setup

To set up recruiting statuses:

1. Use the [Recruiting Status and Reason Page](#) to define status codes and associated reasons for each of the six recruitment areas.
2. Use the [Recruiting Status Area Page](#) and its secondary pages to define:
  - a. The default status that is used for a new (or newly approved) records in each status area.
  - b. Which statuses trigger notifications when they are used.
  - c. When (based on the application disposition) applicants are allowed to withdraw applications using Candidate Gateway self-service.
  - d. The status progression within each recruitment area.
  - e. How applying a particular status in one area can trigger additional status change effects in the same or different areas.

---

**Note:** The system includes a comprehensive set of codes and associated status processing rules. Oracle recommends that you use these delivered statuses and rules rather than setting up your own.

---

### Default Statuses

The system applies different default statuses at different stages:

<b>Processing Stage</b>	<b>Details</b>
Draft	<ul style="list-style-type: none"> <li>• For the Job Opening, Recruitment Summary (disposition), and Job Offer areas, the status definitions on the Statuses and Reasons page include a check box that you use to identify a draft status.  The system uses the draft status as the default status when a new job opening, application, or offer is saved for later without being submitted.</li> <li>• The Applicant and Route status areas do not differentiate between saving for later and submitting, so they do not have a draft status.</li> <li>• The Interview status area does allow users to save for later without submitting, but in this area, records that are saved for later simply do not have a status.</li> </ul>
Pending Approval	For the Job Opening and Job Offer areas, the status definitions on the Statuses and Reasons page include a check box that you use to designate the default approval status. This represents records that have been submitted but are pending approval. If approvals are active, the system applies this status to newly submitted records.
Approval Denied	For the Job Opening and Job Offer areas, the status definitions on the Statuses and Reasons page include a check box that you use to designate the approval denied status, and the system applies this status after an approver denies approval.
Open	For all status areas, the Status Area page includes a check box that you use to designate the default open status. This is applied to records after they are submitted and, if approvals are active, approved.

---

**Note:** Use different status codes to represent Draft, Pending Approval, Approval Denied, and Open statuses.

---

### Status Progression

For each status code, you can define the progression from one status code to another by indicating the statuses that typically occur after the current status.

For example, the next status for a job opening with a status of Open might be Hold, Filled/Closed, or Canceled.

If a user manually updates the status to one that is not configured as a successor, the system displays a warning. The user can choose to ignore the warning and save the new status anyway.



For dispositions (but not for other status areas), flexible recruiting processes can prevent users from manually changing a disposition to an invalid successor.

See [Understanding Flexible Recruiting Processes](#).

## Effect of Status Changes

When the status of an applicant, job opening, or application changes, this can affect the status of other records.

For example, when a recruiter decides to hire an applicant, this affects the Recruitment Summary status of other applicants and affects the job opening status. The following table explains the delivered rules for the Hire status.

<b>Recruitment Area</b>	<b>Records Affected</b>	<b>Impact</b>
Recruitment Summary	Hired applicant	Set status to <i>Hired</i> for the selected job opening.
Recruitment Summary	Hired applicant's other applications	If the hired applicant is linked to other job openings, set the Recruitment Summary status for those applications to <i>Reject</i> and reason code to <i>Selected for Another Position</i> .
Recruitment Summary	Other applicants for the job opening	If all the openings for the job opening are filled, set the Recruitment Summary status to <i>Reject</i> and reason code to <i>Another Applicant was Hired</i> .
Job Opening	Job Opening	If all the openings are filled, set the Job Opening Status to <i>Filled/Closed</i> .

**Note:** This table shows the delivered rules, which we recommend that you use. However, you can adjust the status codes and rules to suit your organization.

There are restrictions on the changes allowed. For example, changing an applicant's status to *Inactive*, doesn't have an impact on the status of a job requisition, but it does have an impact on the status of the applicant's open applications. The following example illustrates how status values in each recruitment area impact statuses in other recruitment areas.

You define the rules for changing status values on the Effects of Status Change page.

For each rule, you define:

- Recruitment area affected.
- The records within the recruitment area that are affected by the status change.

- The new status and reason code that the system applies to those affected records.

This example illustrates the Effects of Status Change page for the *Hired* status.

**Effects of Status Change**

Recruitment Area 3-Recruitment Summary  
Description 090 Hired

Status Changes ? Find | View All First 1 of 4 Last

\*Recruitment Area Job Opening + -  
New Status 110 Filled/Closed  
New Reason  
 Revert to Last Status / Reason

Apply To ? Personalize | Find | View All | 1-2 of 2 First 1-2 of 2 Last

Status	All Reasons	Specific Reason		
010 Open	<input checked="" type="checkbox"/>		+ -	
100 Hold	<input checked="" type="checkbox"/>		+ -	

In this example, when an applicant's application is set to *090 Hired*, the following rule is applied:

- The recruitment area that is affected is *Job Opening*.
- The new status that the system applies is *110 Filled/closed*.

**Note:** This example shows only one of the delivered rules for the Hired status. The Hired status has other rules that you access by clicking the navigation buttons.

## Understanding the Delivered Status Configuration

This topic provides overviews of:

- Delivered dispositions by phase.
- Delivered status codes for other status areas.
- Delivered status change effects.
- Non-configurable status processing.

### Delivered Dispositions By Phase

The following table identifies the dispositions that are delivered for each recruiting phase:

Phase	Dispositions
None	005 Draft

<b>Phase</b>	<b>Dispositions</b>
1 - Applied	<i>010 Applied</i> <i>015 Linked</i> <i>019 Linked Questionnaire</i>
2 - Reviewed	<i>020 Reviewed</i>
3 - Screen	<i>030 Screen</i>
4 - Route	<i>050 Route</i>
5 - Interview	<i>060 Interview</i>
6 - Offer	<i>069 Preliminary Offer Decided</i> <i>070 Offer</i> <i>071 Offer Accepted</i> <i>075 Preliminary Offer Notified</i> <i>076 Preliminary Offer Accepted</i> <i>077 Preliminary Offer Rejected</i>
7 - Hire	<i>078 Hire Decided</i> <i>080 Ready to Hire</i> <i>090 Hired</i>
8 - Hold	<i>100 Hold</i>
9 - Reject	<i>110 Reject</i> <i>112 Failed Prescreening</i> <i>115 Reject Online Screening</i> <i>120 Withdrawn</i> <i>130 Withdrawn Application</i> <i>140 Inactive</i>

## Delivered Status Codes for Other Status Areas

The following table identifies the statuses that are delivered with the system:

<b>Recruitment Area</b>	<b>Status Code</b>
Job Opening	<i>005 Draft</i> <i>006 Pending Approval</i> <i>008 Denied</i> <i>010 Open</i> <i>100 Hold</i> <i>110 Filled/Closed</i> <i>120 Canceled</i>
Applicant	<i>010 Active</i> <i>020 Hired</i> <i>030 Inactive</i> <i>040 Queued</i>
Route	<i>010 Route</i> <i>020 Invite for Interview</i> <i>100 Hold</i> <i>110 Reject</i> <i>120 Withdrawn</i> <i>130 Withdrawn Application</i>
Interview	<i>005 Interview</i> <i>020 Make Offer</i> <i>100 Hold</i> <i>110 Reject</i> <i>120 Withdrawn</i> <i>130 Withdrawn Application</i>

<b>Recruitment Area</b>	<b>Status Code</b>
Offer	<i>005 Draft</i> <i>006 Pending Approval</i> <i>008 Denied</i> <i>010 Extend</i> <i>020 Accept</i> <i>030 Acceptance Withdrawn</i> <i>100 Hold</i> <i>110 Offer Rejected</i> <i>120 Offer Withdrawn</i> <i>130 Withdrawn Application</i>

### Delivered Status Change Effects

The tables in this section summarize the effects of status changes in each recruitment area.

The following general limitations apply to status change effects:

- Changes that affect the route and interview areas affect all routings and all interviews for the application, but changes that affect the offer area affect only the most recent offer.
- Rejecting or withdrawing an application affects only the latest phase of the three phase-specific status areas (route, interview, and offer).

For example, if an application has both routings and interviews, the disposition change that occurs when rejecting or withdrawing the application can cause interview status changes, but routing statuses remain unchanged. If the application also has an offer, then the offer status can change, but the interview and routing statuses remain unchanged.

### Job Opening Status Change Effects

This table lists the delivered effects of status changes in the Job Opening recruitment area.

<b><i>If the Job Opening status is changed to:</i></b>	<b><i>Then look in this recruitment area:</i></b>	<b><i>For statuses equal to:</i></b>	<b><i>And change the status - reason to:</i></b>
<i>Open</i>	Recruitment Summary	<i>Hold</i>	Last Status - Reason

<b><i>If the Job Opening status is changed to:</i></b>	<b><i>Then look in this recruitment area:</i></b>	<b><i>For statuses equal to:</i></b>	<b><i>And change the status - reason to:</i></b>
<i>Hold</i>	Recruitment Summary	<i>Review</i> <i>Linked</i> <i>Applied</i> <i>Screen</i> <i>Route</i> <i>Interview</i> <i>Offer</i>	<i>Hold</i>
<i>Filled/Closed</i>	Recruitment Summary	<i>Review</i> <i>Linked</i> <i>Applied</i> <i>Screen</i> <i>Route</i> <i>Interview</i> <i>Offer</i> <i>Hold</i>	<i>Reject - Another Applicant was Hired</i>
<i>Canceled</i>	Recruitment Summary	<i>Review</i> <i>Linked</i> <i>Applied</i> <i>Screen</i> <i>Route</i> <i>Interview</i> <i>Offer</i> <i>Hold</i>	<i>Reject - Job Opening Cancelled</i>

### **Applicant Status Change Effects**

This table lists the delivered effects of status changes in the Applicant recruitment area.

<b><i>If the Applicant status is changed to:</i></b>	<b><i>Then look in this recruitment area:</i></b>	<b><i>For statuses equal to:</i></b>	<b><i>And change the status - reason to:</i></b>
<i>Inactive</i>	Recruitment Summary for other positions	<i>Review</i> <i>Linked</i> <i>Applied</i> <i>Screen</i> <i>Route</i> <i>Interview</i> <i>Offer</i> <i>Hold</i>	<i>Withdrawn</i>

### Recruitment Summary Status Change Effects

This table lists the delivered effects of status changes in the Recruitment Summary recruitment area.

<b><i>If the Recruitment Summary status is changed to:</i></b>	<b><i>Then look in this recruitment area:</i></b>	<b><i>For statuses equal to:</i></b>	<b><i>And change the status - reason to:</i></b>
<i>Offer</i>	Offer	<i>Hold</i>	Last Status - Reason
<i>Offer Accepted</i>	Offer	<i>Hold</i>	Last Status - Reason
<i>Hired</i>	Job Opening	<i>Open</i> <i>Hold</i>	<i>Filled/Closed</i>
<i>Hired</i>	Applicant	<i>Active</i>	<i>Hired</i>

<b><i>If the Recruitment Summary status is changed to:</i></b>	<b><i>Then look in this recruitment area:</i></b>	<b><i>For statuses equal to:</i></b>	<b><i>And change the status - reason to:</i></b>
<i>Hired</i>	Recruitment Summary for current applicant and other job openings	<i>Review</i> <i>Linked</i> <i>Applied</i> <i>Screen</i> <i>Route</i> <i>Interview</i> <i>Offer</i> <i>Ready to Hire</i> <i>Hold</i>	<i>Reject - Selected for Other Position</i>
<i>Hired</i>	Recruitment Summary for other applicants and current job opening.	<i>Review</i> <i>Linked</i> <i>Applied</i> <i>Screen</i> <i>Route</i> <i>Interview</i> <i>Offer</i> <i>Hold</i>	<i>Reject - Another Applicant was Hired</i>
<i>Hold</i>	Route	<i>Route</i> <i>Invite for Interview</i>	<i>Hold</i>
<i>Reject</i>	Route	<i>Route</i> <i>Hold</i>	<i>Reject</i>
<i>Reject</i>	Interview	<i>Interview</i> <i>Hold</i>	<i>Reject</i>



<b><i>If the Recruitment Summary status is changed to:</i></b>	<b><i>Then look in this recruitment area:</i></b>	<b><i>For statuses equal to:</i></b>	<b><i>And change the status - reason to:</i></b>
<i>Reject</i>	Offer	<i>Extend</i> <i>Hold</i> <hr/> <b>Note:</b> If you require approvals for offers, consider configuring a status change to update offers in <i>Pending Approval</i> status as well. This configuration will cancel the approval process for pending approvals. <hr/>	<i>Offer Rejected</i>
<i>Withdrawn</i>	Route	<i>Route</i>	<i>Withdrawn</i>
<i>Withdrawn</i>	Interview	<i>Interview</i> <i>Hold</i>	<i>Withdrawn</i>
<i>Withdrawn</i>	Offer	<i>Extend</i> <i>Hold</i>	<i>Offer Withdrawn</i>
<i>Withdrawn Application</i>	Route	<i>Route</i>	<i>Withdrawn Application</i>
<i>Withdrawn Application</i>	Interview	<i>Interview</i> <i>Hold</i>	<i>Withdrawn Application</i>
<i>Withdrawn Application</i>	Offer	<i>Extend</i> <i>Hold</i>	<i>Withdrawn Application</i>

### **Route Status Change Effects**

This table lists the delivered effects of status changes in the Route recruitment area.

<b><i>If the Route status is changed to:</i></b>	<b><i>Then look in this recruitment area:</i></b>	<b><i>For statuses equal to:</i></b>	<b><i>And change the status - reason to:</i></b>
<i>Route</i>	Recruitment Summary for current applicant and job opening	<i>Review</i> <i>Linked</i> <i>Applied</i> <i>Screen</i> <i>Hold</i>	<i>Route</i>
<i>Invite for Interview</i>	Recruitment Summary for current applicant and job opening	<i>Review</i> <i>Linked</i> <i>Applied</i> <i>Screen</i> <i>Hold</i>	<i>Route</i>
<i>Hold</i>	Recruitment Summary for current applicant and job opening	<i>Review</i> <i>Linked</i> <i>Applied</i> <i>Screen</i> <i>Route</i>	<i>Hold</i>
<i>Reject</i>	Recruitment Summary for current applicant and job opening	<i>Review</i> <i>Linked</i> <i>Applied</i> <i>Screen</i> <i>Route</i> <i>Hold</i>	<i>Reject</i>

<b><i>If the Route status is changed to:</i></b>	<b><i>Then look in this recruitment area:</i></b>	<b><i>For statuses equal to:</i></b>	<b><i>And change the status - reason to:</i></b>
<i>Withdrawn</i>	Recruitment Summary for current applicant and job opening	<i>Review</i> <i>Linked</i> <i>Applied</i> <i>Screen</i> <i>Hold</i>	<i>Withdrawn</i>

### Interview Status Change Effects

This table lists the delivered effects of status changes in the Interview recruitment area.

<b><i>If the Interview status is changed to:</i></b>	<b><i>Then look in this recruitment area:</i></b>	<b><i>For statuses equal to:</i></b>	<b><i>And change the status - reason to:</i></b>
<i>Interview</i>	Recruitment Summary for current applicant and job opening	<i>Review</i> <i>Linked</i> <i>Applied</i> <i>Screen</i> <i>Route</i> <i>Hold</i>	<i>Interview</i>
<i>Make Offer</i>	Recruitment Summary for current applicant and job opening	<i>Review</i> <i>Linked</i> <i>Applied</i> <i>Screen</i> <i>Route</i> <i>Hold</i>	<i>Interview</i>

<b><i>If the Interview status is changed to:</i></b>	<b><i>Then look in this recruitment area:</i></b>	<b><i>For statuses equal to:</i></b>	<b><i>And change the status - reason to:</i></b>
<i>Hold</i>	Recruitment Summary for current applicant and job opening	<i>Review</i> <i>Linked</i> <i>Applied</i> <i>Screen</i> <i>Route</i> <i>Interview</i>	<i>Hold</i>
<i>Reject</i>	Recruitment Summary for current applicant and job opening	<i>Review</i> <i>Linked</i> <i>Applied</i> <i>Screen</i> <i>Route</i> <i>Interview</i> <i>Hold</i>	<i>Reject</i>
<i>Withdrawn</i>	Recruitment Summary for current applicant and job opening	<i>Review</i> <i>Linked</i> <i>Applied</i> <i>Screen</i> <i>Route</i> <i>Interview</i> <i>Hold</i>	<i>Withdrawn</i>

### **Offer Status Change Effects**

This table lists the delivered effects of status changes in the Offer recruitment area.

<b><i>If the Offer status is changed to:</i></b>	<b><i>Then look in this recruitment area:</i></b>	<b><i>For statuses equal to:</i></b>	<b><i>And change the status - reason to:</i></b>
<i>Extend</i>	Recruitment Summary for current applicant and job opening	<i>Review</i> <i>Linked</i> <i>Applied</i> <i>Screen</i> <i>Route</i> <i>Interview</i> <i>Hold</i> <i>Reject - Offer rejected</i>	<i>Offer</i>
<i>Accept</i>	Recruitment Summary for current applicant and job opening	<i>Review</i> <i>Linked</i> <i>Applied</i> <i>Screen</i> <i>Route</i> <i>Interview</i> <i>Offer</i> <i>Hold</i>	<i>Offer Accepted</i>
<i>Accept</i>	Recruitment Summary for current applicant and other job openings	<i>Review</i> <i>Linked</i> <i>Applied</i> <i>Screen</i> <i>Route</i> <i>Interview</i> <i>Offer</i>	<i>Hold</i>

<b><i>If the Offer status is changed to:</i></b>	<b><i>Then look in this recruitment area:</i></b>	<b><i>For statuses equal to:</i></b>	<b><i>And change the status - reason to:</i></b>
<i>Accept</i>	Recruitment Summary for other applicants for the current job opening	<i>Review</i> <i>Linked</i> <i>Applied</i> <i>Screen</i> <i>Route</i> <i>Interview</i> <i>Offer</i>	<i>Hold</i>
<i>Acceptance Withdrawn</i>	Recruitment Summary for current applicant and job opening	<i>Review</i> <i>Linked</i> <i>Applied</i> <i>Screen</i> <i>Route</i> <i>Interview</i> <i>Ready to Hire</i> <i>Hold</i>	<i>Offer</i>
<i>Acceptance Withdrawn</i>	Recruitment Summary for current applicant and other job openings	<i>Hold</i>	Last Status - Reason
<i>Acceptance Withdrawn</i>	Recruitment Summary for other applicants for the current job opening	<i>Hold</i>	Last Status - Reason

<b><i>If the Offer status is changed to:</i></b>	<b><i>Then look in this recruitment area:</i></b>	<b><i>For statuses equal to:</i></b>	<b><i>And change the status - reason to:</i></b>
<i>Offer Rejected</i>	Recruitment Summary for current applicant and job opening	<i>Review</i> <i>Linked</i> <i>Applied</i> <i>Screen</i> <i>Route</i> <i>Interview</i> <i>Offer</i> <i>Hold</i>	<i>Reject - Offer Rejected</i>
<i>Offer Withdrawn</i>	Recruitment Summary for current applicant and job opening	<i>Review</i> <i>Linked</i> <i>Applied</i> <i>Screen</i> <i>Route</i> <i>Interview</i> <i>Offer</i> <i>Hold</i>	<i>Withdrawn</i>

## Non-Configurable Status Processing

By providing a configurable status framework, Oracle enables you to add additional statuses to meet your organization's need. The system also allows you to change the delivered statuses, but use extreme caution if you do so. The system has non-configurable references to many of the delivered status codes, so be sure to thoroughly test any changes you make.

---

***Warning!*** Oracle recommends that you do not change the delivered status codes because the system contains many non-configurable references to specific codes.

---

For example, in the Recruitment Summary area, the Reject Applicant action always applies status code 110. Therefore, using that code to represent anything other than a rejected status will invalidate the Reject Application action. You can change the description if you prefer a different word rather than *Reject*, but the code itself should always be used to represent a rejected disposition.

The following sections provide examples of non-configurable status code processing for different status areas.

## Recruitment Summary Statuses

The following table lists examples of when the system invokes specific status codes for the recruitment summary (disposition) area.

<b><i>Code and Delivered Description</i></b>	<b><i>Examples of Non-Configurable Processing</i></b>
015 - Linked	The Link Application to Job action uses has a non-configurable default disposition of 015, but users can override the default.
019 - Linked Questionnaire	The Link Applicant to Job Opening action displays a warning if you assign a disposition other than 019 when linking an applicant to a job opening that has a questionnaire, or if you assign disposition 019 to a job opening that does not have questionnaire.
071 - Offer Accepted	The Prepare for Hire action is available if the disposition is 071. (This action is also available if the disposition is 080 -Ready for Hire, 090 - Hired, or 120 - Withdrawn.)
080 - Ready for Hire	The Prepare for Hire action always applies disposition 080.  The Withdraw from Hire action is available only if the applicant's current disposition is 080.
090 - Hired	The post-hire message from the Human Resources system sets the disposition to 090.  The Copy Applicant to Employee action is available only if the disposition is 090.
120 - Withdrawn	Performing the Withdraw from Hire action always applies status 120.
110 - Reject	The Reject Applicant action always applies disposition 110.  The In Process Applicants pivot grid disregards applicants in disposition 110.
112 - Failed Prescreening	The Rejected/Reviewed chart for job openings does not include applicants in disposition 112 in either the applications received or applications rejected data.



<b>Code and Delivered Description</b>	<b>Examples of Non-Configurable Processing</b>
130 - Withdrawn Application	<p>The Withdraw Application action always applies disposition 130.</p> <p>The availability of the Withdraw Application action depends on whether disposition 130 is a successor for the application's current disposition.</p> <p>The option to select the Applicant Withdrawal check box for a disposition (giving an applicant the ability to withdraw an application in Candidate Gateway) depends on whether disposition 130 is a successor for the disposition being configured.</p> <hr/> <p><b>Note:</b> The delivered reason codes for the <i>130 - Withdrawn Application</i> disposition also have non-configurable processing. When an applicant withdraws the application using Candidate Gateway, the system assigns code 010, <i>Candidate Withdrawn</i>. When a recruiting user uses the Withdraw Application action, code 020, <i>Recruiter Withdrawn</i> is the default reason, but the user can change this.</p> <hr/>

## Job Opening Statuses

The following table lists examples of when the system invokes specific status codes for the job opening status area.

<b>Code and Delivered Description</b>	<b>Examples of Non-Configurable Processing</b>
110 - Filled/Closed	The post-hire message from PeopleSoft HCM sets this status if the available openings is zero.
100 - Hold 110 - Filled/Closed 120 - Canceled	The Hold, Close, and Cancel actions on the Search Job Openings page use these status codes when updated the job opening status. If any of these status codes do not exist, the corresponding action does not appear in the Group Action menu.

## Offer Statuses

The following table lists examples of when the system invokes specific status codes for the offer status area.

<b>Code and Delivered Description</b>	<b>Examples of Non-Configurable Processing</b>
020 - Accept	Applied to offers when applicants accept an online job offer in Candidate Gateway or when recruiting users perform the Accept Offer action.

<b>Code and Delivered Description</b>	<b>Examples of Non-Configurable Processing</b>
110 - Reject	Applied to offers when applicants reject an online job offer in Candidate Gateway and when recruiting users perform the Reject Offer action.

## Setting Up Recruiting Statuses

To set up recruiting statuses, use the Status and Reasons (HRS\_STS\_DFN) and Status Area (HRS\_STS\_AREA) components.

**Important!** The delivered system includes complete recruiting statuses definitions, including statuses, recruitment rules, successors, and status change effects. Oracle strongly recommends that you use the delivered statuses and status effects.

## Pages Used to Set Up Recruiting Statuses

<b>Page Name</b>	<b>Definition Name</b>	<b>Usage</b>
<a href="#">Recruiting Status and Reason Page</a>	HRS_STS_DFN	For each of the six recruitment status areas, define status values and associated reasons.
<a href="#">Recruiting Status Area Page</a>	HRS_STS_AREA	Set up status change effects for each of the six status areas.
<a href="#">Status Successors Page</a>	HRS_STS_SUCC_TBL	Define the progression from one status code to another.
<a href="#">Effects of Status Change Page</a>	HRS_STS_EFF_TBL	Define the effects of status changes.

## Recruiting Status and Reason Page

Use the Recruiting Status and Reason page (HRS\_STS\_DFN) to define status values and associated reasons for each of the six recruitment status areas.

Navigation:

**Set Up HCM > Product Related > Recruiting > Recruiting Status and Reason > Recruiting Status and Reason**

This example illustrates the Recruiting Status and Reason page.

**Statuses and Reasons**

Recruitment Area 3-Recruitment Summary

Status ? Find | View All First 6 of 23 Last

\*Status Cd 030

\*Description 030 Screen

Short Description Screen

Recruitment Phase 3-Screen

**Status Attributes ?**

Draft  Open

**Approval Status Attributes ?**

Approval Status  Approval Default  Approval Denied

Only one row for this applicant can have this status

**Associated Reasons**

*Reason Cd	*Description	Short Description		
010	Preliminary Screen	Prelim	+ -	
020	Final Screen	Final	+ -	

<b>Field or Control</b>	<b>Description</b>
<b>Recruitment Area</b>	Displays the recruitment area whose statuses you are defining.
<b>Status Cd (status code) and Description</b>	Enter a unique identifier and a description for each status code.

<b>Field or Control</b>	<b>Description</b>
<b>Recruitment Phase</b>	<p>When defining statuses for the Recruitment Summary area, select a value to identify the overall phase of the recruitment process to which the status (disposition) belongs. Select from these values: <i>1-Applied, 2-Reviewed, 3-Screen 4-Route 5-Interview 6-Offer, 7-Hire, 8-Hold, or 9-Reject.</i></p> <p>When you use the Job Opening page to review the applicants who are associated with the job opening, the number of applicants in each phase of the recruiting process are prominently displayed in a phase progression bar. The phase bar also provides one-click filtering so you can easily restrict the applicant list to include only applicants in a particular phase. Additionally, related content graphs on the Job Opening page and pivot grids on the Recruiting Home page provide analytical tools based on applicant phases.</p> <hr/> <p><b>Important!</b> All non-draft dispositions should be associated with a phase.</p> <hr/> <p>Other areas of the recruiting system also use phases to identify applicants who are at specific points in the recruiting process. For example, the <a href="#">My Alerts Pagelet</a> on the Recruiting Home includes an alert for offers to be prepared. The criteria for identifying offers to prepare includes the following phase-related criteria:</p> <ul style="list-style-type: none"> <li>• The applicant is in the Interview phase with an Interview status that is the designated “complete” status.</li> <li>• The applicant is in the Offer phase, but no offer record exists.</li> </ul> <p>The screening process also looks at the recruitment phase to determine which applicants to process. To prevent applicants in the later phases of the recruiting process from being screened, the system processes only applicants whose dispositions are associated with either the <i>1-Applied</i> phase, the <i>2-Reviewed</i> phase, or no phase at all. (Additionally, the disposition must have the <b>Open</b> check box selected.)</p>

## Status Attributes

<b>Field or Control</b>	<b>Description</b>
<b>Draft</b>	<p>Select to identify the status to be used for records that have been saved but not yet submitted.</p> <p>You must designate exactly one draft status for the status areas for job openings, dispositions (the recruitment summary status area), and offers. In the other status areas (applicant, route, and interview), the Draft check box is disabled.</p> <p>For job openings, the draft status is applied when a user clicks the Save as Draft button on a job opening that has not yet been submitted. Additionally, if job opening approvals are active, the designated draft status is used for new job openings that are created by cloning an existing job opening.</p> <p>For offers, the draft status is applied when a user clicks the Save for Later button on a job offer that has not yet been submitted.</p> <p>For dispositions, the draft status is applied when an applicant who is using Candidate Gateway to apply online saves an in-progress application without submitting it.</p>
<b>Open</b>	<p>Select to indicate that records with this status are active and available for further processing.</p>
<b>Only one row for this applicant can have this status</b>	<p>Select this check box to identify a status that can be used for only one row of data for an applicant. For example, in the Recruitment Summary area, this check box is selected for the delivered <i>Hired</i> status. If an applicant who has already been hired for one job opening is subsequently hired for another job opening, the system display a warning to let the user know that the status should be used for only one record for the applicant. The user can still continue with the action if, for example, the applicant is being hired for multiple job openings or if the applicant was previously hired for a job and subsequently left the job.</p> <p>This field is not visible for the Job Opening recruitment area.</p>

## Approval Status Attributes

There are two recruiting objects that you can configure to require approval: job openings and job offers. The fields in the Approval Status Attributes group box are therefore available only for the job opening and offer recruitment areas.

<b>Field or Control</b>	<b>Description</b>
<b>Approval Status</b>	Select if the status is used during approval processing. When this check box is selected, the <b>Approval Default</b> and <b>Approval Denied</b> check boxes become available for entry so that you can mark the status as the default status when a job opening or offer is either submitted for approval or denied.
<b>Approval Default</b>	Select this check box for the status that the system should apply when a record is submitted for approval.  This check box is available only if the <b>Approval Status</b> check box is selected.
<b>Approval Denied</b>	Select this check box for the status that the system should apply when approval is denied.  This check box is available only if the <b>Approval Status</b> check box is selected.

**Note:** Use the Successors page to indicate an overall default status that is used for approved records and, if approvals are not active, for new records.

### Associated Reasons

<b>Field or Control</b>	<b>Description</b>
<b>Reason Cd</b> (reason code) and Description	Use these fields to optionally create reasons that are associated with the status. Enter a unique identifier and a description for each reason.

## Recruiting Status Area Page

Use the Recruiting Status Area page (HRS\_STS\_AREA) to set up status change effects for each of the six status areas.

Navigation:

**Set Up HCM > Product Related > Recruiting > Recruiting Status Area > Recruiting Status Area**

This example illustrates the Status Area page.

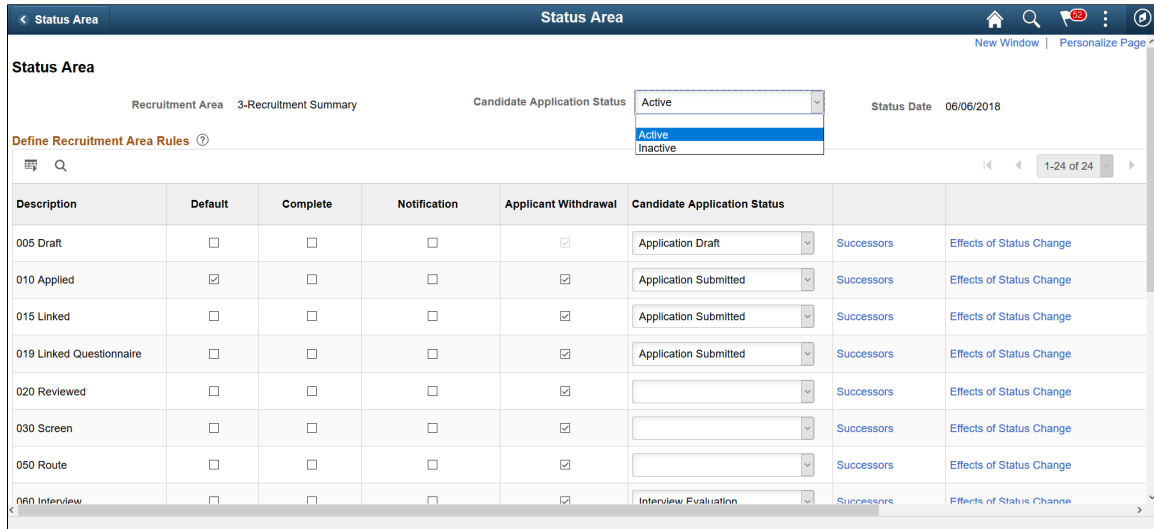

<b>Field or Control</b>	<b>Description</b>
<b>Candidate Application Status</b>	<p>The Candidate Application status will be either <b>Active</b> or <b>Inactive</b>.</p> <p>Inactive will use the application statuses: Submitted, Not Submitted or Withdrawn.</p> <p>By default, the application status is delivered as Inactive.</p> <p>The Candidate Application Statuses is displayed on all existing job application statuses in Candidate Gateway, including all applications started or completed prior to the new status date.</p> <hr/> <p><b>Note:</b> If a status is left unmapped with Candidate Application Status, a warning is displayed during activation. If you choose to ignore this warning, then the old statuses are displayed to applicants for the unmapped items in My Job Information and a no Application Status Information icon will be displayed for them.</p>
<b>Default</b>	<p>Select this check box to indicate the status that the system should apply to new records and, in areas where approvals are active, to newly approved records.</p> <p>For example, when job opening approvals are not active, the default status for the job opening status area is applied when a user clicks the Save and Open button on a new job opening. Additionally, the default status is used for new job openings that are created by cloning an existing job opening.</p> <p>You can select one status only as the default.</p>

<b>Field or Control</b>	<b>Description</b>
<p><b>Complete</b></p>	<p>Select this check box if the status indicates the successful completion of the recruitment process. <i>Successful</i> refers to the most desirable outcome of the process—one that results in a hired applicant. For example, in the Job Opening status area, both <i>Filled/Closed</i> and <i>Canceled</i> are possible final statuses, but only <i>Filled/Closed</i> represents the <i>successful</i> completion of the recruitment process.</p> <p>You can select one status only as the complete status.</p> <p>For the Job Opening, Applicant, and Recruitment Summary status areas, the system displays an error if a user attempts to change a status from the complete status. In the Route, Interview, and Offer status areas, the system displays a warning, but lets the user continue.</p> <p>Examples of how the system uses the Complete status include:</p> <ul style="list-style-type: none"> <li>• On the Recruiting Home Page: Time to Fill pagelet, job openings are considered filled on the date they go into the complete status.</li> <li>• On the Recruiting Home Page: Alerts pagelet, the Job Offers to Prepare alert counts (among other things) applicants who are in the Interview phase and whose status for the Interview status area is the complete status.</li> </ul>
<p><b>Notification</b></p>	<p>Select this check box if you want a notification sent to the recruiters and hiring managers for the job opening when the status is applied.</p> <p>Notifications related to applicant status changes are sent to the recruiters and hiring managers of the applicant's job openings that are in open statuses.</p> <p>For Job Openings, the <i>JobOpeningStsEffect</i> template is used.</p> <p>For Applicants, the <i>ApplicantStsEffect</i> template is used.</p> <p>For all other areas, the <i>OtherStsEffect</i> template is used.</p> <hr/> <p><b>Note:</b> The system sends status change notifications to the email address that is associated with the user's user ID, not the email address that is associated with the user's personal data record.</p> <hr/>



<b>Field or Control</b>	<b>Description</b>
<b>Applicant Withdrawal</b>	<p>This field is available only for the status area <i>3–Recruitment Summary</i> (for dispositions).</p> <p>Select this check box to allow applicants to withdraw applications that are in the indicated disposition. This setting controls the visibility of the Withdraw button on the My Activities page in Candidate Gateway. It does not affect the availability of the Withdraw Application action in Talent Acquisition Manager.</p> <p>To enable an applicant to withdraw an application in a given disposition, you must also use the <a href="#">Status Successors Page</a> to ensure that the disposition <i>130 Withdraw Application</i> is a successor disposition. As delivered, <i>130 Withdrawn Application</i> is a successor for dispositions up to <i>060 Interview</i>.</p> <p>If you select the <b>Applicant Withdrawal</b> check box for a disposition that does not have <i>130 Withdraw Application</i> as a successor, the system displays a message reminding you to set up the proper successor. You will not be able to save until the proper successor is set up every row where the <b>Applicant Withdrawal</b> check box is selected.</p> <p>Applicants are always allowed to withdraw draft applications, so this check box is selected and read-only for the draft disposition.</p>
<b>Successors</b>	Click to display the Status Successors page.
<b>Effects of Status Change</b>	Click to display the Effects of Status Change page.

## Status Successors Page

Use the Status Successors page (HRS\_STS\_SUCC\_TBL) to define the progression from one status code to another.

Navigation:

Click the **Successors** link on the Status Area page.

This example illustrates the Status Successors page.

**Status Successors**

Recruitment Area 3-Recruitment Summary

Description 010 Applied

Status Successor Details ?
Personalize | Find | View 10 | | 
First 1-11 of 11 Last

*Status Successor	Default		
020 Reviewed	<input type="checkbox"/>	+	-
030 Screen	<input type="checkbox"/>	+	-
050 Route	<input type="checkbox"/>	+	-
060 Interview	<input type="checkbox"/>	+	-
070 Offer	<input type="checkbox"/>	+	-
080 Ready to Hire	<input type="checkbox"/>	+	-
090 Hired	<input type="checkbox"/>	+	-
100 Hold	<input type="checkbox"/>	+	-
110 Reject	<input type="checkbox"/>	+	-
120 Withdrawn	<input type="checkbox"/>	+	-
130 Withdrawn Application	<input type="checkbox"/>	+	-

OK
Cancel

<i>Field or Control</i>	<i>Description</i>
<b>Recruitment Area and Description</b>	Identifies the status whose successors you are listing.

## Status Successor Details

<b>Field or Control</b>	<b>Description</b>
<b>Status Successor</b>	<p>Add the status codes that are valid successors to the current status.</p> <p>If a user manually updates the status to one that is not configured as a successor, the system displays a warning. The user can choose to ignore the warning and save the new status anyway.</p> <p>For dispositions, a successor of <i>130 Withdrawn Application</i> enables the Withdraw Application action in Talent Acquisition Manager. This successor is also necessary if you want to select the Applicant Withdrawal check box on the Status Area page so that applicants can withdraw applications using Candidate Gateway.</p> <p>For dispositions (but not for other status areas), flexible recruiting processes can prevent users from manually changing a disposition to an invalid successor. When you create the flexible recruiting process, you define valid transitions for users with different roles, choosing from the successors that you configure here.</p> <p>See <a href="#">Understanding Flexible Recruiting Processes</a>.</p>
<b>Default</b>	Select the check box next to the status that is the most likely successor.

## Effects of Status Change Page

Use the Effects of Status Change page (HRS\_STS\_EFF\_TBL) to define the effects of status changes.

Navigation:

Click the **Effects of Status Change** link on the Status Area page.

This example illustrates the Effects of Status Change page.

The following general limitations apply to status change effects:

- Recruitment areas *1–Job Opening* and *2–Applicant* allow only one status change rule per status. The button for adding an additional status change row to the page is not visible for these recruitment areas.
- Changes that affect the route and interview areas affect all routings and all interviews for the application, but changes that affect the offer area affect only the most recent offer.
- Rejecting or withdrawing an application affects only the latest phase of the three phase-specific status areas (route, interview, and offer).

For example, if an application has both routings and interviews, the disposition change that occurs when rejecting or withdrawing the application can cause interview status changes, but routing statuses remain unchanged. If the application also has an offer, then the offer status can change, but the interview and routing statuses remain unchanged.

<b>Field or Control</b>	<b>Description</b>
<b>Recruitment Area</b> (top of page) and <b>Description</b>	Identifies the status that, when applied, will cause the status effect changes that you configure on this page.

## Status Changes

<b>Field or Control</b>	<b>Description</b>
<b>Recruitment Area</b> (in the Status Changes group box)	<p>Identify the recruitment area that is affected by the status that is shown at the top of the page.</p> <p>If the status that appears at the top of the page is in the Recruitment Summary area, you can select other recruitment areas that are affected by the status change. Otherwise, the only status area that can be changed is <i>Recruitment Summary</i>, and the field is read-only.</p>
<b>Affected Applicant</b>	<p>This field is visible only if the status area to be changed is <i>Recruitment Summary</i>.</p> <p>Select <i>Current Appl / Current Req</i> (current applicant/current requisition) if the new code should be applied to the current applicant that is linked to the current job where the status change is being made.</p> <p>Select <i>Current Appl / Other Job Reqs</i> (current applicant/other job requisitions) if the new status and reason should be applied to the other positions that the current applicant has been linked to.</p> <p>Select <i>Other Appl / Current Job Req</i> (other applicants/current job requisition) if the new status and reason should be applied to other applicants that are linked to the same job and no more openings on the job are available.</p>
<b>New Status and New Reason</b>	<p>Select the status and, optionally, the reason to apply to the affected records.</p>
<b>Revert to Last Status/Reason</b>	<p>Select this check box if the status in the affected recruitment area reverts to the previous status and reason code. Leave the <b>New Status</b> and <b>New Reason</b> fields blank if you select this check box.</p>

## Apply To

<b>Field or Control</b>	<b>Description</b>
<b>Status</b>	<p>Select the statuses that are affected by the status change. You can choose from the status values that are defined for the recruitment area that you selected in the <b>Status Changes</b> group box.</p> <p>For example, if you are defining changes to be made the Recruitment Summary status area (perhaps because of a change to the status in the Interview status area), the drop-down list box includes all Recruitment Summary statuses.</p>
<b>All Reasons</b> and Specific Reason	<p>If the status change should be applied to all reason codes that are associated with the status, select the <b>All Reasons</b> check box. Otherwise, select one reason code in <b>Specific Reason</b>.</p> <p>If the rule applies to some, but not all, of the reasons for a status code, you must list the status code once for each applicable reason.</p>

## Chapter 5

# Setting Up Screening Processes

---

## Understanding Screening Setup

Screening is the process used by recruiters to evaluate a list of potential candidates and narrow the list to a few qualified applicants that can be interviewed or hired. Prescreening is a special use of screening that can filter out applicants even before they submit an application.

In PeopleSoft Talent Acquisition Manager, a job opening can have multiple screening processes, or screening *levels*, and each screening level can evaluate different criteria and use different processing rules.

This overview discusses:

- Screening criteria.
- Processing rules.

## Screening Criteria

Screening criteria refers to the specific attributes that are desirable in an applicant. During screening, the system compares applicant attributes to job opening attributes to determine how well applicants meet the job requirements. Recruiters establish a job opening's criteria from within the Job Opening component, on the Job Opening - Screening Criteria page. This page presents a list of job attributes so that the recruiter can choose which ones to use.

There are four types of job opening attributes that can be used as screening criteria:

- Job Preferences.

Job Preferences from the Job Information section of the job opening page include regular/temporary, full-time/part-time, start date, standard hours, shift, travel percent, minimum and maximum age, sex, citizenship status, and recruiting location.

Job Preferences from the salary information section of the job opening page include minimum salary and minimum grade.

Job Preferences are hard coded and cannot be configured. The Employment questions provides you the flexibility to ask similar questions based on your needs by job opening.

- Education and experience.

Education and experience requirements indicate the number of years of experience required for applicants with various levels of education. To meet education and experience screening criteria, the applicant must have *both* the education level and the minimum amount of experience required for that level.

- Skills questions.

Skills questions enable you to ask job related single-choice, multiple-choice, date related, numeric or open-ended questions to applicants who apply online. If a job opening includes skills questions, the system makes all of the questions available for use during screening.

---

**Note:** Unlike the other types of screening criteria, skills questions are useful only if applicants can submit applications online. Answers to screening questions cannot be entered in the Application Details page.

---

- Employment questions

Employment questions enable you to ask general questions related to employment. These questions can be single-choice, multiple-choice, date related, numeric or open-ended. If a job opening includes employment questions, then the system makes all the employment questions available for use during screening.

- Profile content types.

The Manage Profiles module in PeopleSoft Human Resources provides a flexible architecture for describing the attributes of jobs and individuals. *Content type* is a generic term for an attribute that can be part of a profile. In the context of the recruiting process, content types are attributes that are used to describe job qualifications and the corresponding applicant attributes.

Oracle delivers several content types that are already configured for the recruiting system; you can use Manage Profiles to create more.

Specific types of screening criteria are available only if the job opening template includes the corresponding sections. For example, to screen applicants based on education and experience, the job opening template must include the *Education and Experience* section. To collect applicant information to use when screening on education and experience, the resume template must contain both the *Education History* and *Work History* sections.

The following table summarizes the setup tasks for each type of screening criteria:

<b>Criteria Type</b>	<b>Setup Requirements</b>
Job Preferences	<ul style="list-style-type: none"> <li>• Include the <i>Job Information</i> section and, optionally, the <i>Salary Information</i> section in the job opening template.  The <i>Job Information</i> section is a mandatory part of every job opening template.</li> <li>• Include the <i>Preferences</i> section in the resume template.  This configures the online application pages so that applicants can enter general preferences such as location, work days, regular/temporary, and so forth.</li> </ul> <hr/> <p><b>Note:</b> Job Preferences are hardcoded and can not be configured. The Employment Questions offers the flexibility and configuration for you to ask similar questions based on your needs by job opening.</p> <hr/>



<b>Criteria Type</b>	<b>Setup Requirements</b>
Education and Experience	<ul style="list-style-type: none"> <li>• Include the <i>Education and Experience</i> section in the job opening template.  This configures the Job Opening page to includes a grid where recruiters can enter education and experience requirements.</li> <li>• Include the <i>Education History</i> and <i>Work History</i> sections in the resume template.  This configures the online application pages so that applicants can enter their highest education level and can provide work history details, including start and end dates for each period of employment.</li> </ul>
Employment questions	<ul style="list-style-type: none"> <li>• Include the <i>Employment Questions</i> section in the job opening template.  This configures the Job Opening page to includes a grid where recruiters can add employment questions to the job opening.</li> <li>• Include the <i>Online Questionnaire</i> section in the resume template.  This configures the online application pages so that applicants can see and answer the questions while completing a job application.</li> <li>• Define reusable question definitions that recruiters can associate with job openings.  See <a href="#">Setting Up the Skills and Employment Questions</a>.</li> </ul>
Skills question	<ul style="list-style-type: none"> <li>• Include the <i>Skills Questions</i> section in the job opening template.  This configures the Job Opening page to includes a grid where recruiters can add skills questions to the job opening.</li> <li>• Include the <i>Online Questionnaire</i> section in the resume template.  This configures the online application pages so that applicants can see and answer the questions while completing a job application.</li> <li>• Define reusable question definitions that recruiters can associate with job openings.  See <a href="#">Setting Up the Skills and Employment Questions</a>.</li> </ul>

<b>Criteria Type</b>	<b>Setup Requirements</b>
<p>Profile content types</p>	<ul style="list-style-type: none"> <li>• Include the corresponding section in the job opening template.  This configures the Job Opening page to includes a grid where recruiters can add content items to the job opening.</li> <li>• Include the corresponding section in the resume template.  This configures the online application pages so that applicants can add content items to their applications.</li> <li>• Use the Content Section Configuration page to mark the content type for use in screening, and to choose which of its attributes are used to evaluate the applicant.  See <a href="#">Making Content Types Available for Screening</a>.</li> </ul> <hr/> <p><b>Note:</b> If you use content types other than those that Oracle delivers, you must first set up those content types and, to make them available to the recruiting system, you must add them to the primary person profile that you identified on the Assign Profile Type Defaults page.</p> <hr/> <p>See <a href="#">Choosing the Primary Person Profile Type for Recruiting</a>.</p>

## Processing Rules

This section discusses the different types of screening processing rules and explains where the rules are configured.

### Rules That Apply to a Single Screening Level

To set up screening, you must set up reusable screening level definitions. These include default processing rules that apply to the screening level. When the screening level is used for a specific job opening, recruiters can override most (though not all) of the default settings.

See [Setting Up Screening Level Definitions](#).

Examples of screening level processing rules include:

- Whether the screening level runs automatically during the online application process, and what messages are used to give applicants instructions or results during such screening.

See [Understanding Prescreening and Online Screening](#).

- What percentage of the total possible points the applicant must earn in order to pass the screening level.
- How to determine an applicant's overall score for the screening level, and whether to allow manual determination of pass/fail status in a screening level.

Manual determination of pass/fail status is not applicable to screening levels that run during the online application process (prescreening and online screening).

- What disposition to assign to applicants depending on whether they pass or fail the screening level.

## Rules That Reach Across Multiple Screening Levels

Certain processing rules reach across multiple screening levels.

Screening templates enable you to set up default settings for some such rules; recruiters can override the default settings within individual job openings.

Cross-level settings that you configure in a screening template include:

- Whether applicants must pass the previous level to be included in the subsequent screening level.
- (USF) Various settings that control the classification and ranking of U.S. federal applicants after all screening levels have been processed.

---

**Note:** You cannot use screening templates to set up default settings for *transmutation*, a process used during U.S. federal screening to give candidates an overall score out of 100 based on the results of two separate screening levels. Transmutation settings rules are configured within each job opening.

---

See [Setting Up Screening Templates](#), [\(USF\) Understanding U.S. Federal Screening Setup](#).

## (USF) Federal Preference Items

In the U.S. federal screening process, these preference items entitle applicants to specific advantages during screening:

- Priority placement status.
- Veterans preference.

The system provides setup pages where you define the codes for each of these preference items.

See [\(USF\) Setting Up Preference Programs](#).

---

## Setting Up the Skills and Employment Questions

To set up the Skills questions and Employment questions, use the Answer Definition (HRS\_ANSWER\_DEF), Question Definition (HRS\_QSTN\_DEF), and Question Set Definition (HRS\_QSTN\_SET\_DEF) components.

## Pages Used to Set Up Questionnaires

<i>Page Name</i>	<i>Definition Name</i>	<i>Usage</i>
<a href="#">Recruiting Answer Definition Page</a>	HRS_ANSWER_DEF	Set up answer definitions.
<a href="#">Recruiting Question Definition Page</a>	HRS_QSTN_DEF	Set up question definitions.

<b>Page Name</b>	<b>Definition Name</b>	<b>Usage</b>
<a href="#">Recruiting Question Set Page</a>	HRS_QSTN_SET_DEF	Set up question set definitions.
<a href="#">Question Answers Page</a>	HRS_QSTN_SET_ANS	View answers to questions.

## Understanding Skills and Employment Question Setup

Many organizations include screening questions in their screening process. Talent Acquisition Manager enables you to create questionnaires that are presented to applicants when they use PeopleSoft Candidate Gateway to apply for a job opening. Questions can be general in nature or tailored to a specific job opening.

### Skills and Employment Question Architecture

To set up Skills questions and Employment questions, you create reusable question definitions containing the text of the question. Question definitions can be single choice, multiple choice, date, numeric or open-ended. Multiple-choice questions allow for one or more answers to be selected. Open-ended questions are not associated with answer definitions; applicants enter free-form text answers.

Question sets are groups of questions that can be added to a resume template or job opening all at once. Questions sets exist only to simplify the process of adding the questions; the question set itself does not exist within the template or job opening.

To set up Skills and Employment questions:

1. Create an answer definition for each answer.
2. Create a question definition for each question and, if the question is not open-ended, date type or numeric, then link answers to the question. For Date type or Numeric questions, use the Where Clause section in the Question Definition page to indicate the answer..

During this step, you also assign default points for each of the possible answers to the question.

---

**Note:** The answers and the default points to the answers can be overridden at the Job Opening level.

---

3. (Optional) Create question set definitions and link questions to the question set.

For more details, see [Recruiting Question Definition Page](#)

See the image highlights video on Skills and Employment questionnaire

Video: [Image Highlights, PeopleSoft HCM Update Image 33: New Employment Questionnaire for Candidate Gateway](#)

### Adding Question Sections to Templates

To configure the system to support screening questions, your resume templates and job opening templates must include sections for questions. To create a place for questions in the overall format of the online resume and the job opening:

1. Add the *Skills Questions* and/or *Employment Questions* section to resume templates.

See [Setting Up Resume Templates](#).

2. Add the *Skills Questions* and/or *Employment Questions* section to job opening templates.

See [Setting Up Job Opening Templates](#).

These steps provide the structure for associating questions with applications and with job openings. There are also two ways to associate specific questions directly with template:

- You can add specific questions to the pre-screening tab a resume template; these are used for prescreening when an applicant applies online without selecting a job opening. The skills and/or employment questions added to the Default Questions tab of the resume template is listed for the candidate as Skills Questions and Employment Questions.

When a job opening's recruitment template is associated with a resume template that has Skills and/or Employment questions in the Default Questions tab, the questions are added to the job opening by default.

See [Understanding Prescreening and Online Screening](#).

- You can add a question set to a job opening template; the questions in the set are added to new job openings by default.

## Adding Questions to Job Openings

If the job opening template includes the Skills Questions and/or Employment Questions section, then you can add questions to the job opening. You can add questions individually, or you can load questions from a question set. When you load questions from a question set, you choose which of the questions in the set to add to the job opening; it is not necessary to add the full set.

To expedite data entry, you can associate a default question set with a job opening template. If you do this, the questions in the default question set are automatically brought into any newly created job openings that are based on the template.

When you add questions to a job opening, you indicate the order in which questions appear to applicants. You can therefore intermix the question types. You can override the correct answer at the Job Opening level. You can choose to set a question as required to answer so that candidates do not skip the question. However if the Require Answers to Question option is checked in the site setup page for the site where the job opening is listed, it will supersede the setting set at the job opening level.

If the **Randomize Screening Questions** field on the Recruiting Installation - Jobs page has a *Yes* value, then the system disregards the question order and presents questions to applicants in random order, although open-ended questions still appear last. The Recruiting Installation - Jobs page also has a setting that you can use to randomize answer order for multiple-choice questions.

## Using Questions for Screening

When you use Skills and Employment questions you assign points to the questions.

For single-choice questions, multiple correct answers can be defined with different scoring points even though the candidate can choose only one answer.

For multiple-choice questions, the question definitions include default point values for each answer. Recruiters can override these default point values when they configure screening for a specific job opening.

For open-ended questions, the question definitions include the maximum point value. When you add an open-ended question to a job opening, you assign evaluators who score the applicants' answers and award points accordingly. During screening, the system averages the points awarded by all evaluators (ignoring any who haven't submitted their evaluations) to calculate a single point value for an applicant's answer.

During screening, the system does not award any points for unanswered questions or for open-ended questions that have been answered but not yet evaluated. When reviewing screening results, you can review an applicant's questionnaire to ascertain whether either of these conditions affected the outcome of the screening process.

If you use questions for screening, remember that the only way for applicants to provide answers to screening questions is through Candidate Gateway. Applicants who send their resumes through a job board or email address, or whose applications are entered by a recruiter or administrator using the Create Applicant component, do not see the questionnaire at the time they apply. However, if you use the *Link Applicant to Job* action to associate an applicant to a job opening that includes questions, the system sends the applicant an email asking that the applicant go to Candidate Gateway and answer the question. Applicants who have not previously registered for Candidate Gateway can use a special link in the email to access Candidate Gateway and register; using the link ensures that the system recognizes the newly registered applicant and associates the registration with the existing applicant record. When the applicant signs in to Candidate Gateway, the notification invites the applicant to complete the questionnaire.

See [Linking Applicants to Job Openings](#).

## Changes to Questions

In a question definition, changes that you make to the question text or answer text flow through to job openings that are linked to the question or answer. You can override the correct answer or points to the answers at the Job Opening level. The changes that you make to the questions at the job opening level will not affect the original question definition.

However, any answers that you add to a question or remove from a question do not appear in job openings to which the question is already linked. To update the answer list for a question in a job opening, you need to remove the question from the job opening and then add it back.

Changes that you make to the default points for an answer flow through to questions that have not yet been marked for use during screening. However, once a question is marked for use during screening, the point values for that particular screening process do not change when the default point values change.

## Recruiting Answer Definition Page

Use the Recruiting Answer Definition page (HRS\_ANSWER\_DEF) to set up answer definitions.

Navigation:

**Set Up HCM > Product Related > Recruiting > Screening > Recruiting Answer Definition > Recruiting Answer Definition**

This example illustrates the Recruiting Answer Definition page.



**Answer Definition**

Answer ID 1012

\*Answer Code

\*Description

Short Description

\*Long Description   

58 characters remaining

<i>Field or Control</i>	<i>Description</i>
<b>Answer Code</b>	Enter a code that identifies this answer. This code appears only on search pages and lookup dialog boxes. The system does not require this to be a unique code.
<b>Description</b>	Enter an identifying name for this answer. A descriptive name helps you when you reference the answer definition from within a question definition. Other pages that display answers, however, use the full text of the answer rather than these shorter identifiers.
<b>Long Description</b>	Enter the complete text of this answer.

## Recruiting Question Definition Page

Use the Recruiting Question Definition page (HRS\_QSTN\_DEF) to set up question definitions.

Navigation:

**Set Up HCM > Product Related > Recruiting > Screening > Recruiting Question Definition > Recruiting Question Definition**

This example illustrates the Recruiting Question Definition page for Single Choice question.

### Question Definition

**Question ID** 1004

\*Question Code  \*Question Type

\*Status  Status Date 08/09/2001

\*Description

Short Desc

\*Long Description

**Answers**

*Answer ID	Long Description	Correct Answer	Default Points	Answer Order		
<input type="text" value="1027"/>	No	<input type="checkbox"/>	<input type="text" value="0"/>	<input type="text"/>	+	-
<input type="text" value="1037"/>	Yes	<input checked="" type="checkbox"/>	<input type="text" value="0"/>	<input type="text"/>	+	-



Question Definition page for Multiple Choice question.

< Manager Self Service
Question Definition

[New Window](#) | [Help](#) | [Personalize Page](#)

### Question Definition

**Question ID** 1026  
**\*Question Code**     **\*Question Type**

**\*Status**     **Status Date** 01/08/2009

**\*Description**

**Short Desc**

**\*Long Description**

#### Answers

*Answer ID	Long Description	Correct Answer	Default Points	Answer Order		
<input type="text" value="1060"/>	Square meter	<input checked="" type="checkbox"/>	<input type="text" value="5"/>	<input type="text"/>	+	-
<input type="text" value="1061"/>	Litre	<input type="checkbox"/>	<input type="text" value="0"/>	<input type="text"/>	+	-
<input type="text" value="1063"/>	Pound	<input type="checkbox"/>	<input type="text" value="0"/>	<input type="text"/>	+	-
<input type="text" value="1072"/>	acre	<input checked="" type="checkbox"/>	<input type="text" value="10"/>	<input type="text"/>	+	-

Save
Return to Search
Previous in List
Next in List
Notify
Refresh
Add
Update/Display

Question Definition page for Numeric question.

**Question Definition**

Question ID 4041

\*Question Code 1082 \*Question Type Numeric

\*Status Active Status Date 01/06/2020

\*Description Basic Maths

Short Desc Math

\*Long Description What is twelve times fifteen?

Points 10

**Where Clause**

Condition	Field Name	Operator	Numeric Value		
WHERE	NUMERIC VALUE	=	180.00	+	-

Buttons: Save, Return to Search, Notify, Refresh, Add, Update/Display

Question Definition page for Date type question.

**Question Definition**

Question ID 4020

\*Question Code DATE \*Question Type Date

\*Status Active Status Date 12/20/2019

\*Description Date

Short Desc Date

\*Long Description When did you start your career ?

Points

**Where Clause**

Condition	Field Name	Operator	Date Value		
WHERE	DATE VALUE	>=	01/01/1975	+	-
AND	DATE VALUE	<=	01/01/2019	+	-

Buttons: Save, Return to Search, Previous in List, Next in List, Notify, Refresh, Add, Update/Display

Question Definition page for open ended question.

<b>Field or Control</b>	<b>Description</b>
<b>Question Code</b>	Enter a code that identifies the question. This code appears only on search pages and lookup dialog boxes. The system does not require this to be a unique code.
<b>Question Type</b>	<p>Choose the appropriate question type. The Answers grid changes based on the question type selected. The different question types are:</p> <ul style="list-style-type: none"> <li>• <i>Date</i>. Use this question type if the answer is a date value. Choosing this question type displays a Where Clause answer grid. Users can set the date or the date range using the operators in the Where Clause grid.</li> <li>• <i>Multiple Choice</i>. Use this question type if there are more than one correct answer for a question. The question must have at least two possible answers.</li> <li>• <i>Numeric</i>. Use this question type if the answer is a number. Choosing this question type displays a Where Clause answer grid. Users can set the number or the number range using the operators in the Where Clause grid.</li> <li>• <i>Open Ended</i>. Use this question type if there is no predefined answer for the question. Because open ended questions do not have predefined answer sets, selecting this removes the <b>Answers</b> grid from the page and replaces it with the <b>Maximum Points</b> field.</li> <li>• <i>Single Choice</i>. Use this question type when there is only one correct answer to be selected for the question. The question can have multiple correct answers with points for each of those answers but the user can select only one answer.</li> </ul>

<b>Field or Control</b>	<b>Description</b>
<b>Status</b> and Status Date	Indicate whether the definition is <i>Active</i> or <i>Inactive</i> . Whenever you change the status, the system changes the status date to the current date.
<b>Description</b> and Short Description	Enter an identifying name for this question. A descriptive name helps recruiters identify the question when they manage the list of questions in a job opening or question set.
<b>Long Description</b>	Enter the complete text of this question.
<b>Maximum Points</b>	If this is an open-ended question, enter the maximum number of points (up to 100) that an applicant can receive for answering this question. The actual number of points that the applicant receives is determined by averaging scores that evaluators manually assign. Evaluators who have not yet evaluated the answer are not included in the calculation.

## Answers

This grid does not appear for open-ended, Date and Numeric type questions. Multiple-choice questions must include at least two answers. Single choice questions can have more than one correct answer but the candidate can choose only one answer. The answers appear as check boxes in the online questionnaire. For Date type and Numeric questions, a Where Clause appears where you can specify the condition for the correct answer.

<b>Field or Control</b>	<b>Description</b>
<b>Answer ID</b>	Select an answer to link to the question.
<b>Long Description</b>	After you enter an answer ID, the text of the answer (the long description on the Answer Definition page) appears in this column.
<b>Correct Answer</b>	Select the check box next to any answer that is correct answer for the question. There can be more than one correct answer.  There must be at least one correct answer.

<b>Field or Control</b>	<b>Description</b>
<b>Default Points</b>	<p>Enter the default number of points that an applicant who selects this answer receives during screening. You can assign points to both correct and incorrect answers, depending on your business processes. When applicants can choose more than one answer, the screening process adds the points for all chosen answers to calculate the total points that the applicant is awarded for the question.</p> <p>It is possible to assign negative points to incorrect answers.</p> <p>Recruiters can override the correct answer and default point value of an answer when configuring criteria for a specific screening level in a specific job opening.</p>
<b>Answer Order</b>	<p>Optionally enter numbers to set the order of the answers. This order is used wherever questions and answers appear in Candidate Gateway and Talent Acquisition Manager.</p> <p>If you enter an order for some answers but not others, the answers without orders appear first, followed by the ordered answers.</p> <p>If multiple answers have the same value (or with no value) in this field, the system uses the Answer ID to order those answers.</p> <hr/> <p><b>Note:</b> If the <b>Randomize Screening Answers</b> field on the <u>Recruiting Installation – Jobs Page</u> page has a <i>Yes</i> value, then the system disregards the answer order and presents answers in random order.</p> <hr/>

## Recruiting Question Set Page

Use the Recruiting Question Set page (HRS\_QSTN\_SET\_DEF) to set up question set definitions.

Navigation:

**Set Up HCM > Product Related > Recruiting > Screening > Recruiting Question Set > Recruiting Question Set**

This example illustrates the Recruiting Question Set page.

**Question Set Definition**

**Question Set**

Question Set ID: 1013

\*Question Set Code:

\*Status:  Status Date: 07/31/2001

\*Description:  Competency:

Short Description:

Explanation:

**Questions**

*Question ID	Long Description	Order Number	Action
<input type="text" value="1003"/>	How do you deal with an irate customer on the telephone?	<input type="text"/>	<a href="#">View Answers</a> + -
<input type="text" value="1006"/>	An angry and argumentative customer calls with a question on how to implement software they had purchased from your company, you normally don't handle this type of call nor do you know the answer, What do you do?	<input type="text"/>	<a href="#">View Answers</a> + -

Buttons: Save, Return to Search, Notify, Add, Update/Display

<b>Field or Control</b>	<b>Description</b>
<b>Question Set Code</b>	Enter a code that identifies this question set. This code appears only on search pages and lookup dialog boxes. The system does not require this to be a unique code.
<b>Status and Status Date</b>	Indicate whether the definition is <i>Active</i> or <i>Inactive</i> . Whenever you change the status, the system changes the status date to the current date.
<b>Description</b>	Enter an identifying name for this question set. A descriptive name helps recruiters identify the question set when prompting for a question set to add to a job opening.
<b>Competency</b>	Optionally identify the competency that is assessed through the applicant's answers to the questions in the question set. This is informational only; the competency does not affect the job opening, nor is it added to the job opening when you load the question set.

<b>Field or Control</b>	<b>Description</b>
<b>Explanation</b>	Enter details about the purpose or contents of the question set. This is helpful to anyone who needs to update the question set. It is not visible to users who add the question set to a job opening.

## Questions

<b>Field or Control</b>	<b>Description</b>
<b>Question ID</b>	Enter the ID of each question that you want to add to the question set.
<b>Long Description</b>	After you enter a question ID, the text of the question (the long description on the Question Definition page) appears in this column.
<b>Order Number</b>	<p>Enter numbers to control the default order of the questions in the set. When you load the question set into a job opening, these become the default order numbers in the <b>Screening Questions</b> grid. Users can then modify the order numbers for the individual job opening.</p> <p>The system does not prevent you from assigning the same order number to multiple questions. When you load question set definitions into a job opening, review the default order numbers and update them as necessary to create an unambiguous question order.</p> <p>Because this field accepts only integers, consider using non-consecutive numbers to make it easier to insert additional questions between existing questions.</p> <hr/> <p><b>Note:</b> If the <b>Randomize Screening Questions</b> field on the Recruiting Installation - Jobs page has a <i>Yes</i> value, then the system disregards the question order and presents questions to applicants in random order.</p> <hr/>

<b>Field or Control</b>	<b>Description</b>
<b>Action</b>	<p>Displays a link to the Question Answers page.</p> <p>For open-ended questions, the link text is <i>Open Ended</i>. When you click this link, the Question Answers page displays the text and the maximum point value of the open-ended question.</p> <p>For other questions, the link text is <i>View Answers</i>. When you click this link, the Question Answers page displays the question, its correct and incorrect answers, and the default point value of each answer.</p>

## Question Answers Page

Use the Question Answers page (HRS\_QSTN\_SET\_ANS) to view answers to questions.

Navigation:

Click the link in the **Action** column of the **Questions** grid on the Question Set Definition page.

This example illustrates the Questions Answers page for a multiple-choice question.

The screenshot shows the 'Question Set Definition' page. The 'Question Answers' section displays the following details:

- Question ID:** 1003
- Question Type:** Single Choice
- Description:** Irate Customer
- Long Description:** How do you deal with an irate customer on the telephone?

The 'Answers' section contains a table with the following data:

Answer ID	Description	Correct Answer	Default Points
1026	Hang up on the customer	<input type="checkbox"/>	0
1028	Please the customer	<input checked="" type="checkbox"/>	0

At the bottom of the page, there are 'OK' and 'Cancel' buttons.



Question Answer page: Multiple Choice question

**Question Set Definition**

Question ID 1026  
 Question Type Multiple Choice  
 Description Units for area  
 Long Description What are units are typically used for measuring area?

**Answers**

Answer ID	Description	Correct Answer	Default Points
1060	Square meter	<input checked="" type="checkbox"/>	5
1061	Litre	<input type="checkbox"/>	0
1063	Pound	<input type="checkbox"/>	0
1072	acre	<input checked="" type="checkbox"/>	10

OK Cancel

This example illustrates the Question Answers page for an open-ended question.

**Question Set Definition**

Question ID 1105  
 Question Type Open Ended  
 Description Open Ended - General  
 Long Description What is your opinion of the way in which an organization can leverage efficient administration practices to engage in greater social responsibility? Please answer in paragraph format using no more than 100 words.  
 Maximum Points 10

OK Cancel

Question Answers page: numeric question.

**Question Set Definition**

Question ID 4041  
 Question Type Numeric  
 Description Basic Maths  
 Long Description What is twelve times fifteen?

Points 10

**Where Clause**

Condition	Field Name	Operator	Numeric Value
WHERE	NUMERIC VALUE	=	180.00

OK Cancel

Question Answers page: Date type question

**Question Set Definition**

Question ID 4020  
 Question Type Date  
 Description Date  
 Long Description When did you start your career ?

Points

**Where Clause**

Condition	Field Name	Operator	Date Value
WHERE	DATE VALUE	>=	01/01/1924

OK Cancel

For multiple-choice questions, this page displays the answer choices and their default point values.

For open-ended questions, this page displays the question and its maximum point value.

For Numeric and Date value questions, this page displays the where clause and the default points values.

## Making Content Types Available for Screening

This topic discusses how to configure content types for screening.

### Page Used to Configure Content Types for Screening

<i>Page Name</i>	<i>Definition Name</i>	<i>Usage</i>
<u>Recruiting Content Sections - &lt;Content Type&gt; Page</u>	HRS_JPM_SECT_CFG	Make content types available for use during screening, and select specific properties for the screening process to evaluate.

#### Related Links

[Configuring Profiles for Recruiting](#)

### Recruiting Content Sections - <Content Type> Page

Use the Recruiting Content Sections page (HRS\_JPM\_SECT\_CFG) to make content types available for use during screening and to select specific properties that the screening process can evaluate.

---

**Note:** The page name varies according to which content type you are configuring.

---

Navigation:

**Set Up HCM > Product Related > Recruiting > Templates > Recruiting Content Sections > <Content Type>**

This example illustrates the Recruiting Content Sections - <Content Type> page.

**Competencies**

Status Date    Applicant may add items

Properties						Personalize	Find	First	1-20 of 20	Last
Field Name	Label Text	Required	Summary	Use in Screening	Default					
EFFDT	Effective Date	<input checked="" type="checkbox"/>	<input checked="" type="checkbox"/>							
JPM_CAT_ITEM_ID	Competency	<input checked="" type="checkbox"/>	<input checked="" type="checkbox"/>	<input type="checkbox"/>						
JPM_CAT_ITEM_QUAL	Evaluation Type	<input checked="" type="checkbox"/>	<input checked="" type="checkbox"/>							
JPM_CAT_ITEM_QUAL2	Reviewer ID	<input type="checkbox"/>	<input type="checkbox"/>							
RATING_MODEL	Rating Model	<input checked="" type="checkbox"/>	<input type="checkbox"/>		PSCM					
JPM_RATING1	Proficiency	<input checked="" type="checkbox"/>	<input checked="" type="checkbox"/>	<input checked="" type="checkbox"/>						
JPM_VERIFY_METHOD	Verified By	<input type="checkbox"/>	<input type="checkbox"/>							
JPM_INTEREST_LEVEL	Interest Level	<input type="checkbox"/>	<input type="checkbox"/>							
JPM_PERSON_ID_1	EmplID	<input type="checkbox"/>	<input type="checkbox"/>							
EP_APPRAISAL_ID	Appraisal ID	<input type="checkbox"/>	<input type="checkbox"/>							
JPM_INTEGER_1	Year Last Used	<input type="checkbox"/>	<input type="checkbox"/>							
JPM_YN_1	Reviewer Is Approved	<input type="checkbox"/>	<input type="checkbox"/>	<input type="checkbox"/>						
JPM_INTEGER_2	Year Acquired	<input type="checkbox"/>	<input type="checkbox"/>							
JPM_DECIMAL_2	Years Of Experience	<input type="checkbox"/>	<input type="checkbox"/>							
JPM_YN_2	Review Active	<input type="checkbox"/>	<input type="checkbox"/>	<input type="checkbox"/>						

You can access this page only for content types that belong to the primary person profile that you specify on the Assign Profile Type Defaults page. These are the content types that are available to the recruiting system.

See [Choosing the Primary Person Profile Type for Recruiting](#).

### Properties

This grid lists all properties of the selected content type.

<b>Field or Control</b>	<b>Description</b>
<b>Field Name</b> and Label Text	These fields identify a specific field that is part of the content type definition. For example, the content type <i>Competencies</i> , which you use for applicant competency ratings, includes fields such as Rating Model and Proficiency.

<b>Field or Control</b>	<b>Description</b>
<b>Use in Screening</b>	<p>Select this check box to make the field available for screening. Fields where this check box is selected are included in the criteria list on the Job Opening - Screening Criteria page, where you choose which of the available criteria to use in a specific screening level.</p> <p>For example, the delivered configuration for the Competencies content type has only one field that is available for screening: the Proficiency field. When you add a competency to a job opening, you will enter data such as the competency name, rating type, and the rating. But when you configure the screening criteria for the job opening, the rating is the only competency-related information that is listed in the grid where you select screening criteria. (Because the rating is associated with a particular competency and rating model, the screening process automatically looks for the rating for that particular competency).</p> <p>If you were to change the configuration for competencies so that the competency name was the only field used in screening, then the screening process would simply check that the applicant's application lists the competency, regardless of the applicant's rating.</p> <hr/> <p><b>Note:</b> If the JPM_CAT_ITEM_ID attribute is selected and one or more additional fields are also selected, then only additional fields are used for screening. For example, when configuring competencies, if you select both the JPM_CAT_ITEM_ID (Competency) field and the JPM_RATING1 (Proficiency) field, only the Proficiency field is available for screening.</p>

**Note:** The other elements on this page are not used to set up screening process.

## Setting Up Screening Level Definitions

To set up screening levels, use the Screening Levels (HRS\_SCREEN\_TBL) component.

### Page Used to Set Up Screening Level Definitions

<b>Page Name</b>	<b>Definition Name</b>	<b>Usage</b>
<a href="#">Screening Definition Page</a>	HRS_SCREEN_TBL	Set up screening definitions.

## Understanding Screening Levels

Screening levels enable you to evaluate applicants multiple times, applying different screening criteria or different processing rules during each successive round of screening.

### Screening Level Usage

A job opening can include multiple screening levels, each with its own set of screening criteria and its own processing rules. Within a job opening, screening levels are assigned an order so that recruiters can process each level in its logical sequence.

For example, you might use a preliminary screening level to select candidates who meet basic employment eligibility requirements, then a final screening level to assess the applicant's job qualifications.

Using multiple screening levels is a useful strategy for filtering out unqualified applicants before rating the remaining applicants (for example, entering competency ratings).

### Screening Level Setup

There are two aspects of setting up screening levels for a job:

- When you implement the recruiting system, you create reusable screening level definitions and add them to templates so that they are automatically added to newly created job openings.

These screening level definitions include general processing rules; they do not list the actual qualifications to be assessed.

You add one or more screening level definitions to a screening template, and you add one screening template to a recruitment template. Because every job opening is associated with a recruitment template, creating a job opening causes the system to add the appropriate screening levels to the job opening.

See [Understanding Recruiting Templates](#).

- When you are running the recruiting system, users set up screening for specific job openings by establishing the actual screening criteria for each screening level in the job opening.

Users can also add or remove screening levels for the job opening if the default set of screening levels is not satisfactory.

The following diagram illustrates the steps to be taken during system implementation, when you set up screening levels and add them to templates, and the steps to be taken at runtime, when users establish screening levels for a particular job opening and define the job-specific screening criteria.

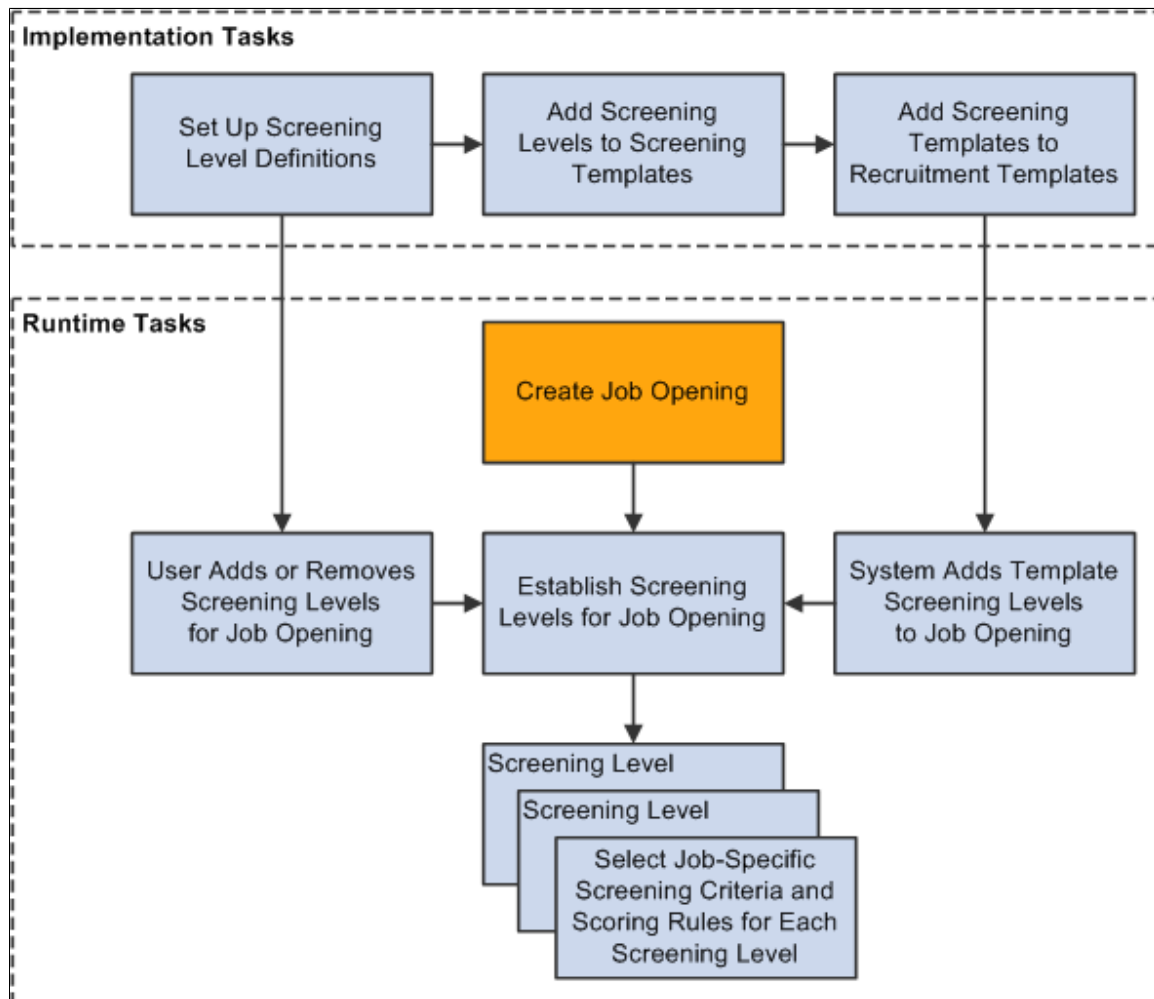

## Process Settings

The screening level definition includes default values for these process settings:

- The threshold for passing the screening level.

When users define the job-specific criteria for a screening level, they establish point values for each item that is evaluated. When the screening process runs, it determines how many of the total available points each applicant has earned. Applicants pass or fail the screening level depending on whether they earn enough points to meet the passing percentage in the screening level definition.

See [Job Opening - Screening Criteria Page](#).

- Dispositions to assign to applicants when applying screening results.

*Dispositions* are statuses in the Recruitment Summary status area, which tracks the applicant's overall status with regards to a particular job opening. When you apply screening results, you assign dispositions based on whether the applicant passed or failed the screening level.

- Rules for assigning applicants an overall score for the screening level.

There are two options for setting the overall score:

- Award *raw points*, the total number of points that the applicant earned by meeting specific screening criteria.

This option enables you to see exactly how well each applicant met the screening criteria.

- Award specific numbers of points for passing and for failing.

For example, during U.S. federal screening for salaried positions, applicants who pass the first screening level all receive 70 points, while applicants who fail that level receive 0 points.

The screening level definition includes additional settings that you use to configure prescreening and online screening.

See [Understanding Prescreening and Online Screening](#).

## (USF) U.S. Federal Screening Setup

The U.S. federal screening process requires very specific processing rules. You set up some of these rules in the job opening rather than in the screening level definition. Certain scoring rules, however, can be defined in screening level templates so that the settings will correctly default into the job opening.

See [\(USF\) Understanding U.S. Federal Screening Setup](#).

## Understanding Prescreening and Online Screening

If applicants use PeopleSoft Candidate Gateway to apply online, you can configure the system to evaluate the applicants during the application process. To do this, you create screening levels for *prescreening* or *online screening*.

### Prescreening

Prescreening occurs at the very beginning of the application process. Typically, you use prescreening to ensure that applicants meet basic requirements such as being able to legally to work in your country.

If prescreening is active, then the guided application process includes a Prequalify step that appears before any other step other than the optional Start step. The Prequalify step displays single choice, multiple-choice, date and numeric type questions that the applicant must answer before continuing. You can mark them as required if you do not want the candidate to skip the questions.

When the applicant continues to the next step, the system evaluates the answers immediately. The system then presents the applicant with a message that depends on whether the applicants passed prescreening. Applicants who pass are permitted to continue with the job application. Applicants who fail are informed that they do not meet your qualifications and that they may not continue with the application.

Regardless of whether the applicant passes prescreening, the system creates an application record. If the applicant failed prescreening, the system assigns the fail disposition that you chose in the screening level definition. Oracle delivers a *Failed Prescreening* disposition to use for this purpose. If the applicant passed prescreening, the application remains in draft status until it is submitted, at which point the passing status is applied unless online screening runs and applies a different status.



To implement prescreening for specific job openings, you create a prescreening screening level and add it to a job opening's list of screening levels.

An applicant who passes prescreening for a job opening and then applies again for the same job opening must still complete the prescreening step when reapplying.

If an applicant applies for more than one job at once, the system merges the prescreening questions from all selected job openings. If questions are duplicate across job openings, only one question is presented. However, if answers to questions are different (overridden), then the same question is displayed multiple times appended with the job opening description.

You can also define prescreening in your resume template.

- The questions that you include in the Pre-Screening tab in the resume template are added as pre screening questions to new job openings that use that template.

You still need to indicate whether the questions should actually be used in any of the job opening's screening levels.

- If an applicant applies without selecting a job opening, the system invokes the questions in the Default Questions tab in the default resume template for the site.

In the Resume Template component, you do not reference a separately-defined screening level. Instead, you use the Pre Screening page and Default Questions page , which includes the Skills and Employment questions along with a list of prescreening questions.

See [Setting Up Resume Templates](#).

A screening level for prescreening has the following characteristics:

- It is always the first screening level in any screening template or job opening where it is included.  
The system always inserts the screening level in this position, and you cannot change the order.
- The definition must include messages text IDs for the pass and fail messages that Candidate Gateway presents to the applicant.
- Single-choice, Multiple-choice, Date and numeric questions are the only allowable screening criteria. Open-ended questions are not permitted.
- A job opening can include only one prescreening level.

The job opening can have both a prescreening level and an online screening level, but only one of each.

## Online Screening

Online screening occurs after an applicant submits an application for a job opening. It is not applicable to applicants who apply without selecting a job.

When the applicant submits the application, the system immediately processes the screening level and optionally presents the applicant with a message related to the results of the online screening process. For example, an applicant who passes the screening level might see a message indicating that the application has been accepted, while an applicant who fails the screening level might see a message indicating that the application has been rejected because the applicant does not have the necessary job qualifications.

When online screening is used, the system assigns the applicant the pass or fail disposition that you indicate in the screening level definition. Oracle delivers a *Reject Online Screening* disposition to use for applicants who fail online screening

A screening level for online screening has the following characteristics:

- In the screening level sequence for a screening level or job opening, online screening always comes before all other screening levels except the prescreening level (if any).

The system always inserts the screening level in this position, and you cannot change the order.

- The definition can include optional messages text IDs for pass and fail messages for Candidate Gateway to present to the applicant.
- Single-choice, Multiple-choice, Date, and numeric questions are the only allowable questions; open-ended questions are not permitted.
- Other than open-ended questions, online screening criteria can include all of the same types of criteria as standard screening levels.
- A job opening can include only one online screening level.

## Screening Definition Page

Use the Screening Definition page (HRS\_SCREEN\_TBL) to set up screening definitions.

Navigation:

**Set Up HCM > Product Related > Recruiting > Screening > Screening Levels > Screening Definition**

This example illustrates the Screening Definition page.

### Screening Level Description

Enter basic information about the screening level.

<b><i>Field or Control</i></b>	<b><i>Description</i></b>
<b>Status</b>	Select whether this screening level is <i>Active</i> or <i>Inactive</i> .

<b>Field or Control</b>	<b>Description</b>
<b>Description</b>	<p>The system uses the full description (rather than the short description) to identify the screening level on the various recruiting pages that includes references to screening levels.</p>
<b>Letter</b>	<p>Select the default letter to send to applicants who fail this screening level. The letter is added to the queue for the Generate Recruitment Letter (HRSLETTR) process after screening results are applied.</p> <p>The drop-down list box includes all of the letters in the HRS_APP_LET report definition, which includes letters for various purposes. Take care to select the appropriate letter. The sample rejection letter that Oracle delivers is HRS_APP_LETTER_IR.</p> <hr/> <p><b>Note:</b> Prescreening and online screening levels do not use this setting.</p> <hr/> <p>See <a href="#">Generate Recruitment Letters Page</a>.</p> <p>Users can override this default selection when they configure job-specific criteria for the screening level on the Job Opening Screening - Criteria page.</p>
<b>Pre Screening and Online Screening</b>	<p>Select one of these check boxes to mark this as a screening level for either prescreening screening or as online screening. You cannot select both check boxes.</p> <p>Leave both check boxes deselected if you are defining a standard screening level.</p> <p>See <a href="#">Understanding Prescreening and Online Screening</a>.</p>

### Status Definition

Your choices in these fields provide default values for the equivalent fields on the Job Opening - Screening Criteria page (the page where recruiters configure the screening level for a specific job opening). Recruiters can override the default statuses, but not the associated messages.

See [Job Opening - Screening Criteria Page](#).

<b>Field or Control</b>	<b>Description</b>
<b>Pass Status and Pass Reason</b>	<p>Optionally select the default disposition (and, if desired, an associated reason) to assign when an application passes this screening level.</p> <p>Typically, you assign the <i>Screen</i> disposition for standard screening levels, and you either leave the fields blank or select the <i>Applied</i> disposition for online screening and prescreening.</p> <p>For prescreening, the Pass Status is not applied until the application is submitted.</p>
<b>Fail Status and Fail Reason</b>	<p>Select the default disposition (and, if desired, an associated reason) to assign applicants who fail this screening level. This setting is optional in the screening definition, but when you set up prescreening for a specific job opening, it is required. (It is never required for standard screening and online screening).</p> <p>Typically, you assign the <i>Reject</i> disposition for standard screening levels, the <i>Failed Prescreening</i> disposition for prescreening, and the <i>Reject Online Screening</i> disposition for online screening.</p>
<b>Pass Message Text ID and Fail Message Text ID</b>	<p>If either the <b>Pre Screening</b> or <b>Online Screening</b> check box is selected, select the IDs for the messages that Candidate Gateway presents to applicants who pass and who fail this screening level. If neither check box is selected, leave these fields blank.</p> <hr/> <p><b>Note:</b> Messages are mandatory for prescreening and optional for online screening. Standard screening levels do not use these settings.</p> <hr/>

## Scoring Definition

Your choices in these fields automatically populate the equivalent fields on the Job Opening - Screening Criteria page. Recruiters can override the default values.

<b>Field or Control</b>	<b>Description</b>
<b>Percent Needed to Pass</b>	<p>Enter the minimum percentage amount of the total possible points for all screening criteria that an applicant must have to pass the screening level.</p> <hr/> <p><b>Note:</b> Unless all questions have the same point value, this percentage is <i>not</i> necessarily the same as the percentage of questions that the applicant must answer correctly.</p> <hr/> <p>For U.S. federal salaried screening, the first screening level typically requires applicants to achieve 100% to pass.</p> <p>For U.S. federal hourly screening, the first screening level typically requires applicants to achieve 50% to pass.</p> <p>For both types of U.S. federal screening, you can typically leave these fields blank for the second screening level, which typically uses transmutation to calculate a score.</p>
<b>Use Raw Points</b>	<p>Select this check box if you want applicant's scores for the screening level to be the total points that the applicant earned by meeting individual screening criteria for this screening level.</p> <p>If you select this check box, do not enter values in the <b>Points Assigned for Pass</b> and <b>Points Assigned for Fail</b> fields.</p>
<b>Maximum Points to Assign</b>	<p>If you select the <b>Use Raw Points</b> check box, use this field to optionally enter a maximum number of points to assign, regardless of the applicant's raw points.</p>
<b>Points Assigned for Pass and Points Assigned for Fail</b>	<p>Enter scores to assign to all applicants who pass or fail this screening level. Do not enter a value if you are using raw points as the applicant's score.</p> <p>To assign zero points when an applicant fails the screening level, enter <i>0</i> rather than leaving the field blank.</p>
<b>Manually Assign Status</b>	<p>Select this check box to allow recruiters to manually set an applicant's the pass/fail status for a screening level. Recruiters can set this status with or without running the screening process, which will still calculate the applicant's score and set an initial pass/fail status if it runs.</p> <p>When this check box is selected, the rest of the scoring-related page elements become read-only.</p>

## (USF) Setting Up Preference Programs

To set up U.S. federal preference programs, use the Veterans Preference (HRS\_G\_VET\_PRF\_TBL) and Priority Placement (HRS\_G\_PR\_PL\_TBL) components.

**Important!** Oracle provides options that you can use to achieve compliance, but you are responsible for configuring the system to comply with applicable regulations.

### Pages Used to Set Up U.S. Federal Screening Processes

<i>Page Name</i>	<i>Definition Name</i>	<i>Usage</i>
<a href="#">(USF) Priority Placement Page</a>	HRS_G_PR_PL_TBL	Review and configure priority placement codes.
<a href="#">(USF) Setup Veterans Preference Page</a>	HRS_G_VET_PRF_TBL	Review and configure veterans preference codes.

### Understanding Priority Placement Processing

Some applicants are entitled to automatic consideration for job openings that meet certain criteria, even if the applicant hasn't specifically applied for the job opening.

Priority placement processing is governed by the internal policies of and the regulations issued by the U.S. Office of Personnel Management (OPM).

#### Priority Placement Processing

Priority placement codes are linked to both applicants and job openings. The configuration for a priority placement code indicates what type of priority processing an applicant with the code receives with regards to job openings that have the same priority placement code, job level, and salary grade.

For each code, there can be different types of priority processing depending on the job opening's type: internal, merit promotion, or open requisition. (The Recruitment Type field on the Job Opening page contains this designation.)

The types of priority processing options are:

- Must Select
- Must Consider
- None

At the beginning of the applicant screening process, you run the RS - Priority Placement (HRS\_PRI\_PLCM) Application Engine process to assess applicants with priority placement and add the ones with *Must Select* or *Must Consider* status as applicants to job openings. You can run this process for all open job openings or for just one job opening.

See [\(USF\) Running the Priority Placement Process](#).

At the end of the applicant screening process, score thresholds are applied to classify the candidates as qualified, well-qualified, or best-qualified. The system then considers these qualification classifications along with the applicants's priority processing status and places applicants in these four categories:

- Category 1: Qualified, well qualified, and best qualified applicants with *Must Select* priority placement.
- Category 2: Well qualified and best qualified applicants with *Must Consider* priority placement.
- Category 3: Best qualified applicants with no priority placement.
- Category 4: Qualified and well qualified applicants with no priority placement.

The screening rules determine which categories of applicants are included in the final ranking.

The rules enable you to include different categories for competitive applicants and noncompetitive applicants.

## Delivered Priority Placement Codes

Oracle delivers the following priority placement code settings:

<b>Priority Placement Code</b>	<b>Weight</b>	<b>Description</b>
CTP	6	Career Transition Assistance Plan
ICT	4	Interagency Career Transition Assistance Plan
PPP	5	Priority Placement Program
RLP	3	Re-employment Priority List
RRS	5	Regional Reduction

## Understanding Veterans Preference Codes

Veterans preference codes represent categories of entitlement to preference in the federal service based on active military service that was terminated honorably. Veterans preference processing is governed by the internal policies of and the regulations issued by OPM.

### Veterans Preference Processing

Veterans preference code definitions include a description, a recruitment code, and the number of points to add to the applicant's screening score.

Screening for a job opening can be configured so that when an application includes a veterans preference code, the associated point value is added to that applicant's final screening score during the ranking process that produces the final Certificate of Eligibles.



---

**Note:** The veterans preference points do not affect the scores for individual screening levels, only the final cumulative score that is used for ranking.

---

Veteran status, which is different from veterans preference codes, can also be used as a tie-breaker during the ranking process.

### Delivered Veterans Preference Codes

Oracle delivers the following veterans preference codes:

<b>Veterans Preference Code</b>	<b>Recruitment Code</b>	<b>Points</b>	<b>Description</b>
1	NV	0	Designates a nonveteran.
2	TP	5	Five-point preference that is granted to a preference-eligible veteran who does not meet the criteria for one of the types of 10-point preferences listed.
3	XP	10	Ten-point (other) preference; granted to recipients of the Purple Heart, persons with a noncompensable service-connected disability (less than 10 percent), widow or widower, or mother of a deceased veteran, or spouse or mother of a disabled veteran.
4	CP	10	Ten-point compensable preference based on a service-connected disability of 10 percent or more, but less than 30 percent.
6	CPS	10	Ten-point compensable preference based on a service-connected disability of 30 percent or more.

### (USF) Priority Placement Page

Use the Priority Placement page (HRS\_G\_PR\_PL\_TBL) to review and configure priority placement codes.

Navigation:

**Set Up HCM > Product Related > Recruiting > Screening > Priority Placement Screening > Priority Placement**

This example illustrates the Priority Placement page.

### Priority Placement Information

<i>Field or Control</i>	<i>Description</i>
<b>Effective Date</b> and Status	Priority placement codes that are currently <i>Active</i> are available for use.
<b>Description</b>	Identifies the priority placement code. This is the description that users see when adding priority placement codes to applications or job openings.
Priority Placement Weight	A value of 1 is the highest weight. During the ranking process, an applicant with a priority placement weight of 1 will be ranked before someone with a priority placement weight of 2.

## Job Opening Types

<i>Field or Control</i>	<i>Description</i>
<b>Recruitment Type</b>	<p>The page lists the three types of job openings so that you can assign different priority placement processing rules for each. The three types of job openings are <i>Internal</i>, <i>Merit Promotion</i>, and <i>Open Requisition</i>.</p> <p>Talent Acquisition Manager identifies each of these types of job openings using the Recruitment Type field on the Job Opening page.</p>
<b>Job Opening Selection Criteria</b>	<p>Select the priority placement processing to give to applicants for each type of job opening. Choose <i>Must Select</i>, <i>Must Consider</i>, or <i>None</i>.</p>

## (USF) Setup Veterans Preference Page

Use the Setup Veterans Preference page (HRS\_G\_VET\_PRF\_TBL) to review and configure veterans preference codes.

Navigation:

**Set Up HCM > Product Related > Recruiting > Screening > Veterans Preference Screening > Setup Veterans Preference**

This example illustrates the Setup Veterans Preference page.

The screenshot shows the 'Setup Veterans Preference' page with the following fields and values:

- Effective Date:** 01/01/1900
- Status:** Active
- Description:** 5 Point
- Short Description:** 5 Point
- Recruitment Code:** TP
- Recruitment Points:** 5

### Veterans Preference Information

Enter the basic information about the veterans preference. Select a recruitment code and assign the points to it.

<b>Field or Control</b>	<b>Description</b>
<b>Effective Date</b> and Status	Veterans preference codes that are currently <i>Active</i> are available for use.
<b>Description</b>	Identifies the veterans preference code. This is the description that users see when adding veterans preference codes to applications.
<b>Recruitment Code</b>	Identifies the recruitment code.  See <a href="#">Understanding Veterans Preference Codes</a> .
<b>Recruitment Points</b>	Enter the number of points that are associated with this veterans preference code.

## Chapter 6

# Setting Up Recruiting Roles and Security

---

## Understanding Recruiting Security

This overview discusses:

- Recruiting privileges granted through recruiting role types.
- Job opening security.
- Applicant security.

## Recruiting Privileges Granted Through Recruiting Role Types

*Recruiting Role Types* enable you to group standard PeopleTools roles to control certain recruiting privileges. The *Recruiter*, *Hiring Manager*, and *Recruitment Administrator* recruiting role types each have specific privileges. Oracle delivers four additional predefined recruiting role types that do not convey any privileges other than the ability to clone job openings—a privilege that is given to users who have any recruiting role type.

See [Assigning PeopleTools Roles to Recruiting Role Types](#).

### Cloning Privileges

Users who are associated with any recruiting role type have access to the clone job opening function on the Job Opening page.

### Hiring Team Association Privileges

The ability to add users to a job opening's hiring team is limited based on whether the users are associated with certain recruiting role types.

The following table lists the five types of hiring team members and describes any associated recruiting role type requirements:

<b><i>Hiring Team Group</i></b>	<b><i>Who Can Be Added to the Group</i></b>
Recruiter	Only users who are associated with the <i>Recruiter</i> recruiting role type.
Hiring Manager	Only users who are associated with the <i>Hiring Manager</i> recruiting role type.

<b>Hiring Team Group</b>	<b>Who Can Be Added to the Group</b>
Interviewer Interested Party Screening Team	Association with a recruiting role type is not required for users to be added to the hiring team in these capacities.  For example, any user can be added as an interviewer, even if that user is not associated with a recruiting role type.

## Administrator Privileges

Users who are associated with the *Recruitment Administrator* recruiting role type are called recruiting administrators.

Recruiting administrators are the only users who can:

- Access eligibility & identity information for applicants.
- Change the status of draft applicants.
- Access a comprehensive list of person profiles when creating a job opening.  
 Other users can only access their own profile or the profiles of their direct reports.
- Change the recruitment template on a job opening.
- Edit job opening details when the job opening status is Hold, Cancelled, or Closed.
- Override the status of a job opening.

Non-administrators can close, cancel, or place job openings on hold by performing certain actions that are available on the Search Job Openings page, but they cannot directly edit the status field in the job opening.

- Approve transactions that are waiting for approval from another user.  
 For example, administrators approve a job opening by directly editing the job opening status or by overriding the job opening’s approval status.
- (AUS) Invoke the Create Salary Package Model and Copy Salary Package actions for applicants.

Recruiting administrators can access all recruiting actions, and they have standard access to other recruiting data. For example, they can:

- Access all recruiting actions even if your flexible processing configuration limits which actions other users can perform.
- Access all applicants.
- Access job openings that they create, where they are on the hiring team, and where they have access to the job opening department by virtue of the department security tree.
- Access all public applicant notes regardless of job opening or applicant security.

They cannot access private notes created by other users.

## Job Opening Security

The following people have access to job openings:

- The job opening creator and hiring team.

The hiring team consists of the people who are individually identified in the job opening as recruiters, hiring managers, interviewers, interested parties, or screening team members.

- Approvers and their proxies, if job opening approvals are active.

An additional type of access to job openings depends on the type of applicant security you use. Standard and enhanced applicant security are described in more detail below, but in short:

- Under standard applicant security, users can also access job openings if they have access to the job opening's department through the department security tree.
- Under enhanced applicant security, users cannot access job openings based on the department security tree. Users must have a direct association with a job opening (as creator, hiring team member, or approver) to access a job opening.

### Setting Up Job Opening Access for Recruiting Team Members

Members of a job opening's hiring team gain access to job openings through a permission list that is explicitly configured to provide this access. To configure this permission list:

1. Create or identify a permission list that you will use for this purpose.
2. Access that permission list in the "Security by Permission List Page" (Application Fundamentals) (**Set Up HCM > Security > Core Row Level Security > Security by Permission List**)
3. In the **Security Set** field, select *RSOPN*.
4. In the **Security Type** grid, add a row for the security access type *031* (Recruiting Team).

The system displays EmplID for the Key 1 field. Leave this field empty. This security access type has fixed key values so you do not need to specify any EmplID values.

5. To associate the permission list with individual users, assign the permission list to one or more roles, and assign the roles to those users who need recruiting team access.

## Applicant Security

Access to applicant data depends on whether the user has standard applicant security or enhanced applicant security.

### Standard Applicant Security

With Standard applicant security, the only restrictions on applicant data are based on which pages the user can access.

For example, users with access to the Search Applicants page can see all applicants. Users can select the "Search My Applicants" check box to filter the search results to include only applicants who are

associated with the user's own job openings. However, this is just an optional filter, as the user can simply deselect the check box to search for other applicants.

A user who does not have access to the Search Applicant page could still have access to the Manage Applicant page. The user can therefore access the applicant data using links on pages such as the Recruiting Home or the Manage Job Opening page. The user can therefore view only applicants who are associated with job openings to which the user has access. However, the Manage Applicant page shows all of the applicant's jobs. The user therefore can see if the applicant has applied for jobs to which the user does not have access.

## Enhanced Applicant Security

Enhanced applicant security is configured for recruiting role types—it is not a system-wide setting.

With enhanced applicant security, users cannot see applications for jobs to which they do not have access. They see only applicants who applied for the user's own job openings and applicants who applied without a job opening.

(Remember that enhanced applicant security also has a narrower definition of the user's own job openings. Department tree security is not applicable, so the user must be the creator or a hiring team member for the job opening. Approver access is not relevant to enhanced applicant security because there are no applicants for job openings that are pending approval.)

Enhanced applicant security ensures that pages throughout the recruiting system show only information related to the user's own job openings. For example, on the Manage Applicant page, users sees only their own jobs. If an applicant applies for five jobs, and the user only has access to two of them, the user sees only those two jobs on the Manage Applicant page.

For a more details description of enhanced applicant security, see [Understanding Enhanced Applicant Security](#).

---

## Understanding Enhanced Applicant Security

This topic provides an overview of enhanced applicant security.

This video also provides an overview of enhanced applicant security:

Video: [PeopleSoft HCM 9.2 Image 24 Highlights: Control Access to Applicant Data](#)

## Principals of Enhanced Applicant Security

This section discusses the basic principals of enhanced applicant security.

### What Does Enhanced Applicant Security Do?

Users subject to enhanced applicant security can see:

- Applicants who are associated with the user's own job openings.
- Applicants who applied without a job opening.

The user's own job openings are those where the user is the creator or a member of the hiring team.



---

**Note:** Under enhanced applicant security, users do not have access to job openings through department tree security.

---

### Who is Subject to Enhanced Applicant Security?

The enhanced applicant security setting is associated with recruiting role types. Recruiting role types are, in turn, associated with PeopleTools roles. Therefore, a user's PeopleTools roles determine which role type(s) they have and whether they are subject to enhanced applicant security. There is no system-wide setting for enhanced applicant security.

Use the [Recruiting Roles Page](#) to activate enhanced applicant security for specific recruiting role types.

A user with multiple recruiting role types is subject to enhanced applicant security only if all of the role types use it. For example, suppose you activate enhanced applicant security for the *Hiring Manager* recruiting role type, but not for the *Recruiter* recruiting role type. A user with both of these recruiting role types is not subject to enhanced applicant security. That is, the least restrictive applicant security setting is used.

---

**Note:** Enhanced applicant security cannot be activated for the *Recruitment administrator* recruiting role type, so recruiting administrators are never subject to this security even if they also have additional recruiting role types.

---

### Does Enhanced Applicant Security Apply to Reports?

Enhanced applicant security does not apply to reports. To restrict access to the data in the reports, use PeopleTools security to restrict access to the reports entirely.

## Pages Impacted by Enhanced Applicant Security

The following tables describe how enhanced applicant security is applied on pages throughout the recruiting system.

---

**Important!** Throughout this section, the user's job openings are those where the user is the creator or is on the hiring team. The user's applicants are those who applied for the user's job openings or who applied without a job opening.

---

### Global Search

<i>Page</i>	<i>Page Differences Under Enhanced Applicant Security</i>
<a href="#">Global Search for Applicants</a>	The search results include only the user's applicants.

<b>Page</b>	<b>Page Differences Under Enhanced Applicant Security</b>
<u>Global Search for Job Postings</u>	<p>The search finds both internal and external postings for the user’s job openings. Clicking a posting displays the <u>View Job Posting Page</u>. The standard related actions for recruiting users are available.</p> <p>If the user has an applicant role, the search finds all internal postings (postings that the user could apply for). Clicking these postings displays the applicant-facing Job Description page. The standard set of related actions for applicants is available.</p>

### Recruiting Home

<b>Pagelet</b>	<b>Page Differences Under Enhanced Applicant Security</b>
<u>My Job Openings Pagelet</u>	<p>The personalization options for this pagelet does not include the <i>All Jobs</i> display option.</p> <p>The available display options are <i>Jobs Assigned to Me</i>, <i>Jobs Associated with Me</i>, and <i>Jobs Created by Me</i>.</p> <p>If a user who was using this personalization option becomes subject to enhanced applicant security, the system changes the personalization option to <i>Jobs Assigned to Me</i>.</p>
<u>My Applicants Pagelet</u>	<ul style="list-style-type: none"> <li>• The job count in the <b>Jobs Applied</b> column does not include job openings to which the user does not have access.</li> <li>• The <b>Last Job Applied To</b> column identifies the most recent job application to which the user has access.</li> <li>• The icons in the Resume, Application, and Print columns all act on the application shown in the <b>Last Job Applied To column</b></li> </ul>
<u>Job Opening Open and Close Trend Pivot Grid</u> <u>Job Opening Aging Analysis Pivot Grid</u> <u>Time to Fill Pivot Grid</u>	<p>These pivot grids show statistical data for the user’s job openings; other job openings are excluded from the data set.</p>

<b>Pagelet</b>	<b>Page Differences Under Enhanced Applicant Security</b>
<u>In Process Applicants Pivot Grid</u>	<p>This pivot grid always shows data for the applicants who are associated with the user’s job openings, but with enhanced applicant security, the user’s job openings are only those where the user is the creator or on the hiring team (and not openings where access would otherwise be given through the department security tree.)</p>

## Job Openings

<b>Pagelet</b>	<b>Page Differences Under Enhanced Applicant Security</b>
<u>Search Job Openings Page</u>	<p>In the Search Criteria section:</p> <ul style="list-style-type: none"> <li>• The <b>Job Opening ID</b> field is restricted to the user’s job openings.</li> <li>• The <b>My Association</b> field does not include the option to search for <i>All Jobs</i>.</li> </ul> <p>Under standard applicant security, this option enables searching for job openings to which the user has access through the department security tree in addition to job openings where the user is the creator or on the hiring team. This is not a valid option under enhanced applicant security.</p> <ul style="list-style-type: none"> <li>• The <b>My Association</b> fields does not include the option to search for <i>Jobs Associated with me</i>.</li> </ul> <p>Under enhanced application security, leaving the <b>My Association</b> field blank searches for all job openings associated with the user, so it would be redundant to offer <i>Jobs Associated with me</i> as a search option.</p> <p>In the Search Results section, the search results display only the user’s own job openings.</p>

## Job Postings

<b>Page</b>	<b>Page Differences Under Enhanced Applicant Security</b>
<a href="#"><u>Search Job Postings Page</u></a>	The search results include only postings for the user’s job openings.
<a href="#"><u>Manage External Postings Page</u></a>	<ul style="list-style-type: none"> <li>• The <b>Job Opening</b> search criteria field is restricted to the user’s job openings.</li> <li>• The search results include only postings for the user’s job openings.</li> </ul>

## Applicants

<b>Page</b>	<b>Page Differences Under Enhanced Applicant Security</b>
<a href="#"><u>Manage Applicant page: Applicant Activity Tab: Current Status Section</u></a>  <a href="#"><u>Manage Applicant Page: Applicant Activity Tab: History Section</u></a>	<p>The <b>Applicant Activity</b> grid lists only applications for the user’s job openings and applications without any job openings.</p> <p>Users do not see anything to make them aware of additional applications for other job openings.</p>
<a href="#"><u>Manage Applicant page: Applicant Activity Tab: Interview Schedule/Evaluation Section</u></a>	Users can see and access interviews and interview evaluations only for the job openings to which they have access and for applications with no job opening.
<a href="#"><u>Manage Applicant Page: Notes Tab</u></a>	<p>A combination of a note’s job opening and audience (public or private) determines which notes are visible in the <b>Notes Summary</b> grid.</p> <ul style="list-style-type: none"> <li>• Public notes with job openings are visible to users who are associated with the job opening.</li> <li>• Public notes that are not associated with any job openings are visible to all users.</li> <li>• Private notes can only be seen by the author, regardless of whether the note is associated with any job openings.</li> </ul>

<b>Page</b>	<b>Page Differences Under Enhanced Applicant Security</b>
<u>Applicant Notes Page</u>	<ul style="list-style-type: none"> <li>• In the grid where users add job openings to the applicant note, the Job Opening ID field is restricted to the user's job openings.</li> <li>• Instructional text explains how the note's job openings and audience control which users can see the note.</li> <li>• If a user saves a public note that is not associated with a job opening, a warning message states that all users will be able to see the note.</li> </ul> <p>As long as enhanced applicant security is enabled for at least one recruiting role, all users see this warning, including users to whom enhanced applicant security does not apply.</p>
<u>Application Details Page</u>	<ul style="list-style-type: none"> <li>• The grid that lists the job openings for the application shows only the user's job openings and rows with no job opening.</li> <li>• When adding job openings to the grid, users can only prompt for or enter their own job openings.</li> </ul>

## Applicant Searches

<b>Page</b>	<b>Page Differences Under Enhanced Applicant Security</b>
<p><a href="#">Search Applicants Page: Quick Search Tab</a></p> <p><a href="#">Search Applicants Page: Keyword Search Tab</a></p> <p><a href="#">Search Applicants Page: Advanced Search Tab</a></p>	<p>The Use Saved Search field on the Keyword Search, Advanced Search, and Profile Match does not list public searches that are associated with job openings to which the user does not have access.</p> <p>The Search Criteria section in the Quick Search and Advanced Search has these differences when a user is subject to enhanced applicant security:</p> <ul style="list-style-type: none"> <li>• Selecting the <b>Search My Applicants</b> check box limits the search results to applicants who applied for the user’s job openings.</li> </ul> <p style="padding-left: 40px;">This check box thus filters out applicants who applied without a job.</p> <ul style="list-style-type: none"> <li>• The Job Opening ID field is restricted to the user’s job openings.</li> </ul> <p>The Search Results section for Quick Search, Keyword Search, and Advanced Search has these differences when a user is subject to enhanced applicant security:</p> <ul style="list-style-type: none"> <li>• The search results include only applicants for job openings to which the user has access and applicants who applied without a job opening.</li> <li>• In the search results grid, the <b>Date Applied</b> and <b>Jobs Applied</b> values are based only on the job openings to which the user has access.</li> </ul>
<p><a href="#">Search Applicants Page: Profile Match Tab</a></p>	<ul style="list-style-type: none"> <li>• In the Search Criteria section, the <b>With Job Opening ID</b> field is restricted to the user’s job openings.</li> <li>• If a user searches for job openings, the Search Results section includes only job openings to which the user has access.</li> <li>• If a user searches for applicants, the results include only applicants to which the user has access.</li> <li>• When the search results grid lists applicants, the <b>Date Applied</b> and <b>Jobs Applied</b> fields are based only on the job openings to which the user has access.</li> </ul>

<b>Page</b>	<b>Page Differences Under Enhanced Applicant Security</b>
<u>Browse Applicants Page</u>	<p>These applicant fields consider only job openings to which the user has access: <b>Jobs Applied</b>, <b>Last Job Applied To</b>, the Application icon, and the Print icon.</p> <p>(The user’s security type does not make a difference in which applicants appear. This page always shows only applicants for the job openings where the user is on the hiring team.)</p>
<u>Saved Searches Page</u>	<ul style="list-style-type: none"> <li>• Saved searches that are based on job opening criteria are visible only if the user has access to the job opening.</li> <li>• Users can see their own compliance searches, but they cannot see public compliance searches saved by other users.</li> </ul> <p>Recruiting administrators and users who are not subject to enhanced applicant security can still see public compliance searches saved by other users.</p>

## Applications

<b>Page</b>	<b>Page Differences Under Enhanced Applicant Security</b>
<u>Search Applications Page</u>	<p>In both the Quick Search and the Advanced Search:</p> <ul style="list-style-type: none"> <li>• The <b>Search My Applicants</b> check box does not appear because searches are always limited to “my applications” under enhanced applicant security.</li> <li>• The <b>Job Opening ID</b> field is restricted to the user’s job openings.</li> </ul>
<u>Manage Application Page: Notes Tab</u>	<p>A combination of a note’s job opening and audience (public or private) determines whether the note is visible in the <b>Notes Summary grid</b>.</p> <ul style="list-style-type: none"> <li>• Public notes with job openings are visible to users who are associated with the job opening.</li> <li>• Public notes that are not associated with any job openings are visible to all users.</li> <li>• Private notes can only be seen by the author, regardless of whether the note is associated with any job openings.</li> </ul>

## Interviews

<b>Page</b>	<b>Page Differences Under Enhanced Applicant Security</b>
<a href="#">Select Job Opening for Interview Page</a>	The job opening list includes only openings to which the user has access.
<a href="#">Interview Calendar Page</a>	<ul style="list-style-type: none"> <li>• If the calendar includes an interview for a job opening to which the user does not have access, the user can still click the interview time to access the <a href="#">Interview Schedule Page</a>, but the interview schedule is read-only.</li> <li>• In each calendar entry, the applicant’s name is a link only if the user has access to the applicant (by virtue of the applicant’s association with a job opening to which the user has access).</li> <li>• In each calendar entry, the job posting title is a link only if the user has access to the job opening.</li> </ul>

## Additional Applicant Actions

<b>Page</b>	<b>Page Differences Under Enhanced Applicant Security</b>
<a href="#">Link Applicant to Job Opening Page</a>	<ul style="list-style-type: none"> <li>• The <b>Applicant</b> field allows only applicants who applied for the user’s job openings or who applied without a job opening.</li> <li>• The <b>Job Opening ID</b> field allows only the job openings to which the user has access.</li> <li>• If an applicant has multiple applications, linking an applicant to a job opening adds that job opening to the most recent application, even if the user does not have access to any of the job openings in the most recent application.</li> </ul> <p>After the additional job opening is added to the most recent application, the user gains access to that application. However, the user still cannot see which other job openings the applicant applied for.</p>



<b>Page</b>	<b>Page Differences Under Enhanced Applicant Security</b>
<u>Send Correspondence Page</u>	<ul style="list-style-type: none"> <li>• If the <b>Job Openings</b> field is editable, the <b>Job Opening ID</b> field allows only the job openings to which the user has access.  The Job Opening ID is editable appears when the user performs the Send Correspondence action without the context of an application—for example, from the Search Applicants page.</li> <li>• Instructional text explains how the job openings and public/private setting control the visibility of the applicant note that gets created.  The applicant note is subject to the same enhanced applicant security as all other applicant notes.</li> <li>• If a user sends public correspondence that is not associated with a job opening, a warning message states that all users will be able to see the applicant note that gets created.  As long as enhanced applicant security is enabled for at least one recruiting role, all users see this warning, including users to whom enhanced applicant security does not apply.</li> </ul>

<b>Page</b>	<b>Page Differences Under Enhanced Applicant Security</b>
<p><u>Forward Applicant Page</u></p>	<ul style="list-style-type: none"> <li> <p>• If the <b>Job Openings</b> field is editable, the <b>Job Opening ID</b> field allows only the job openings to which the user has access.</p> <p>The Job Opening field is editable when the user performs the Forward Applicant action without the context of an application—for example, from the Search Applicants page.</p> </li> <li> <p>• Instructional text explains how the job openings and public/private setting control the visibility of the applicant note that gets created.</p> <p>In general, the applicant note is subject to the same enhanced applicant security as all other applicant notes. The exception is that users (other than the author) with enhanced applicant security are not shown the full message text from the Forward Applicant transaction. Instead, In this scenario, the Manage Applicant page: Notes tab replaces the message details with the text <i>Applicant &lt;name&gt; is forwarded to &lt;recipient email address&gt;</i>.</p> </li> <li> <p>• If a user forwards an applicant when there is no job opening and the transaction is public, a warning message states that all users will be able to see the applicant note that gets created.</p> <p>As long as enhanced applicant security is enabled for at least one recruiting role, all users see this warning, including users to whom enhanced applicant security does not apply.</p> </li> <li> <p>• The default message includes the template text, with the phrase <i>&lt;enter your text here&gt;</i> added at the beginning.</p> <p>Users with standard applicant security do not see the template text in the Message field. Instead, the template text is added when the user sends. These users can preview the message text to see template text before sending.</p> </li> <li> <p>• If at least one recruiting role type is subject to enhanced applicant security, then all users see the <b>Include Resume</b> check box on the Forward Applicant page.</p> <p>This check box lets users choose whether to send the applicant’s resume. If all users have standard applicant security and the check box is therefore not visible, the</p> </li> </ul>

<b>Page</b>	<b>Page Differences Under Enhanced Applicant Security</b>
	applicant’s resume is always attached to the forwarding email.
<u>Manage Applicant List Page</u>	<ul style="list-style-type: none"> <li>• When adding applicants to a list, the user can only add applicants who applied for the user’s job openings or who applied without a job opening.</li> <li>• When viewing lists, the user sees only applicants who are associated with the user’s job openings or applicants who applied without a job opening.</li> <li>• The <b>Most Recent Note</b> and <b>Note Created By</b> fields for an applicant show information about the most recent note to which the user has access.</li> </ul> <p>Users have access to public notes that are not associated with job openings, public notes that are associated with the user’s job openings, and private notes.</p>

## Assigning PeopleTools Roles to Recruiting Role Types

To set up recruiting roles, use the Recruiting Recruiter Roles (HRS\_ROLE\_DEFN) component.

### Page Used to Assign PeopleTools Roles to Recruiting Role Types

<b>Page Name</b>	<b>Definition Name</b>	<b>Usage</b>
<u>Recruiting Roles Page</u>	HRS_ROLE_DEFN	Associate PeopleTools roles with recruiting role types and choose whether to apply enhanced applicant security to the recruiting role type.

### Recruiting Roles Page

Use the Recruiting Roles page (HRS\_ROLE\_DEFN) to associate PeopleTools roles with recruiting role types and to choose whether to apply enhanced applicant security to the recruiting role type.

Navigation:

**Set Up HCM > Recruiting > Recruiting Roles**

This example illustrates the Recruiting Roles page.

### Recruiting Roles

\*Recruiting Role Type

\*Effective Date

Restrict Applicant Access ?

Roles <span style="float: right;">?</span>	Personalize   Find	First <span style="font-size: 0.8em;">◀</span> 1-2 of 2 <span style="font-size: 0.8em;">▶</span> Last
Role Name	Description	
<input type="text" value="Recruiter"/> <span style="float: right;">🔍</span>	Recruiter	<span style="border: 1px solid #ccc; padding: 2px 5px;">+</span> <span style="border: 1px solid #ccc; padding: 2px 5px;">-</span>
<input type="text" value="Recruiting Manager"/> <span style="float: right;">🔍</span>	Recruiting Manager	<span style="border: 1px solid #ccc; padding: 2px 5px;">+</span> <span style="border: 1px solid #ccc; padding: 2px 5px;">-</span>

<b>Field or Control</b>	<b>Description</b>
Recruiting Role Type	<p>The system identifies recruiting users through the use of recruiting role types.</p> <p>The seven delivered recruiting role types are <i>Recruitment Administrator</i>, <i>Federal Recruiter</i>, <i>Hiring Manager</i>, <i>RS Approval Administrator</i> (recruiting solutions approval administrator), <i>RS Technical Administrator</i> (recruiting solutions technical administrator), <i>Recruiter</i>, and <i>Recruiting User</i>.</p> <p>Users with PeopleTools roles that are associated with any of the recruiting role types have cloning privileges</p> <p>Users with PeopleTools roles that are associated with the <i>Hiring Manager</i> recruiting role type can be added to a job opening as a hiring manager.</p> <p>Users with PeopleTools roles that are associated with the <i>Recruiter</i> recruiting role type can be added to a job opening as a recruiter.</p> <p>Users with PeopleTools roles that are associated with the <i>Recruitment Administrator</i> recruiting role type have additional privileges.</p> <p>See <a href="#">Recruiting Privileges Granted Through Recruiting Role Types</a>.</p>

<b>Field or Control</b>	<b>Description</b>
<p><b>Restrict Applicant Access</b></p>	<p>Select this check box to activate enhanced applicant security for the recruiting role type. With this setting:</p> <ul style="list-style-type: none"> <li>The only job openings that a user can view or access are those where the user is the creator or a member of the hiring team.</li> </ul> <p>This differs from standard security in that users do not gain access to job openings through the department security tree.</p> <ul style="list-style-type: none"> <li>The only applicants that a user can view or access are those who applied for job openings to which the user has access and those who applied without a job opening.</li> </ul> <p>This differs from standard security, which does not limit access to applicants.</p> <p>See <a href="#">Understanding Enhanced Applicant Security</a>.</p> <p>This check box is not available for the <i>Recruitment Administrator</i> recruiting role type. Recruiting administrators always have full access to all job openings and applicants.</p> <p>Users are subject to enhanced applicant security only if this check box is selected for <i>all</i> of the user’s recruiting role types. In other words, the system uses the least restrictive applicant security setting.</p>
<p><b>Roles</b></p>	<p>Select the PeopleTools roles to associate with the recruiting role type.</p>

**Related Links**

[Delivered Permission Lists and Roles](#)



## Chapter 7

# Setting Up Additional Recruiting Definitions

## Setting Up Recruiting Locations

To set up recruiting locations, use the Recruiting Locations (HRS\_LOCATION) component.

### Page Used to Set Up Recruiting Locations

<i>Page Name</i>	<i>Definition Name</i>	<i>Usage</i>
<u>Recruiting Locations Page</u>	HRS_LOCATION	Define the geographical categories that will be exposed to applicants, and associate those recruiting-specific locations with physical locations and with other lower-level recruiting locations.

## Understanding Recruiting Locations

Recruiting locations enable you to classify jobs geographically in the way that makes the most sense to your recruiting process. Recruiting locations can be as broad or narrow as you like.

When jobs are posted to Candidate Gateway, the recruiting location is visible to applicants, and applicants can search for jobs based on recruiting location. Applicants can also specify recruiting location preferences in their applications, and recruiters can then use that as search criteria when searching for applicants.

A job opening with multiple target openings can be associated with multiple recruiting locations. You must provide the number of target openings for each recruiting location.

Recruiting locations can contain other recruiting locations. In this situation, the recruiting location facet on the Candidate Gateway job search and on the [Browse Job Openings Page](#) includes hierarchical locations. For example, you could set up a recruiting location for California that contains recruiting locations for Northern California and Southern California. If there are jobs in either the Northern California recruiting location or the Southern California recruiting location, the facets for those two recruiting location become visible only after the applicant clicks the higher-level California recruiting location. And when the applicant clicks the California recruiting location facet, the search results include jobs that are associated with the California recruiting location, the Northern California recruiting location, and the Southern California recruiting location.

Recruiting locations can also be associated with physical locations that you set up in your core Human Resources tables. Through this association, recruiting locations are associated with the country for the physical location. The system uses this information to determine whether to display USA-specific data elements (such as self-identification details for collecting gender and ethnicity information) to applicants

when they apply for jobs using Candidate Gateway. When determining if a job opening is in the USA, the system looks at the physical locations for all of the job's recruiting locations.

## Recruiting Locations Page

Use the Recruiting Locations page (HRS\_LOCATION) to define the geographical categories that will be exposed to applicants, and associate those recruiting-specific locations with physical locations and with other lower-level recruiting locations.

Navigation:

**Set Up HCM > Product Related > Recruiting > Recruiting Locations > Recruiting Locations**

This example illustrates the Recruiting Locations page.

The screenshot shows the 'Recruiting Locations' page. At the top, there is a 'Location Details' section with the following fields: 'Recruiting Location' (1005), '\*Status' (Active), '\*Description' (United States), and 'Short Description' (US). Below this is a table with columns for 'Location' and 'Description'. The table has three rows, each with a search icon and a plus/minus button. The first row shows '1120 West', the second row shows '1125 Midwest', and the third row shows '1130 East'. The table also includes navigation controls like 'Personalize', 'Find', 'First', '1-3 of 3', and 'Last'.

Every recruiting location should be associated with at least one location or recruiting location. Do not leave the Location grid empty.

**Note:** In each row, select either a physical location or another recruiting location, but not both.

<b>Field or Control</b>	<b>Description</b>
<b>Location</b>	Select the physical location that is associated with the recruiting location. Define physical locations on the "Location Address Page" (Application Fundamentals).



<i>Field or Control</i>	<i>Description</i>
<b>Recruiting Location</b>	<p>Select a recruiting location that is a subset of the current recruiting location. Do not associate a recruiting location with itself.</p> <p>Nested recruiting locations appear as hierarchical facets on the Candidate Gateway job search page and on the <a href="#">Browse Job Openings Page</a>. The hierarchical facets for recruiting location are limited to five levels (the top level and up to four levels of nested recruiting locations). Therefore, the best practice is to avoid nesting recruiting locations any deeper than that.</p>

---

**Important!** If you make changes to your recruiting location hierarchy, you must perform a full rebuild of your job posting indexes. Updating the existing index might not capture the change. See [Building Recruiting Search Indexes](#).

---

## Setting Up the Job Posting Description Library

To set up the job posting description library, use the Posting Descriptions (HRS\_JO\_PST\_DSC\_TBL) and Posting Descriptions Library (HRS\_JO\_PST\_LIB\_TBL) components.

### Pages Used to Set Up the Job Posting Description Library

<i>Page Name</i>	<i>Definition Name</i>	<i>Usage</i>
<a href="#">Posting Description Type Page</a>	HRS_JO_PST_DSC_TBL	Define posting description types.
<a href="#">Posting Description Library Page</a>	HRS_JO_PST_LIB_TBL	Create posting descriptions.

### Understanding the Job Posting Description Library

Job postings that are posted to a job board or intranet include a description of the job opening. When you create job postings, you can optionally bring in predefined content from the posting description library. Using content from the library enables you to standardize job posting content.

---

**Note:** You also have the option to enter freeform text and graphics when you create a job posting.

---

Posting description types are categories of boilerplate text. For example, you may want categories for information that:

- Positions your organization within the market.
- Outlines the job responsibilities.
- Lists the qualifications that an applicant must have for this job opening.

- Explains how to apply for the job opening.

When you create a library entry, you associate it with a specific description type.

## Posting Description Type Page

Use the Posting Description Type page (HRS\_JO\_PST\_DSC\_TBL) to define posting description types.

Navigation:

**Set Up HCM > Product Related > Recruiting > Job Posting Description Types > Posting Description Type**

This example illustrates the Posting Description Type page.

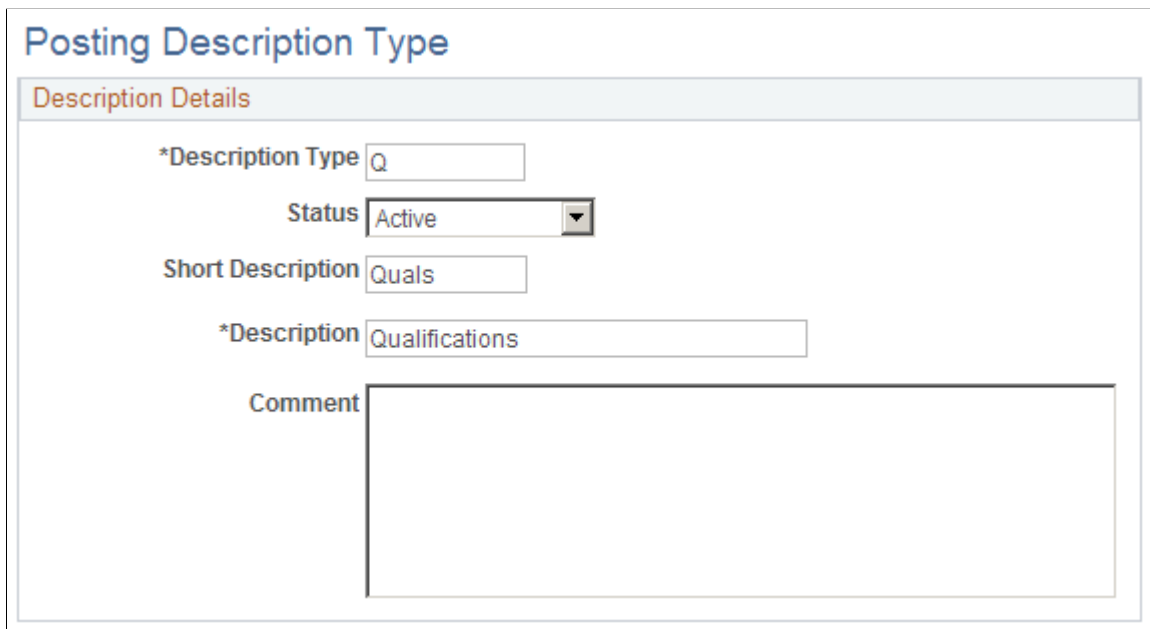

The screenshot displays the 'Posting Description Type' page. The title 'Posting Description Type' is at the top in blue. Below it is a section header 'Description Details' in orange. The form contains the following fields:

- \*Description Type: Text input field containing 'Q'.
- Status: Dropdown menu showing 'Active'.
- Short Description: Text input field containing 'Quals'.
- \*Description: Text input field containing 'Qualifications'.
- Comment: Large empty text area.

## Posting Description Library Page

Use the Posting Description Library page (HRS\_JO\_PST\_LIB\_TBL) to create posting descriptions.

Navigation:

**Set Up HCM > Product Related > Recruiting > Posting Description Library > Posting Description Library**

This example illustrates the Posting Description Library page.

### Posting Description Library

**Description Details**

Description Type Other Information  
 Description ID 002

**\*Description Label**

**Description**

*Identification of promotion potential in this position does not constitute a commitment or an obligation on the part of management to promote the employee selected at some future date.*

*Promotion will depend upon administrative approval and the continuing need for an actual assignment and performance of higher level duties.*

<b>Field or Control</b>	<b>Description</b>
<b>Description Label</b>	Enter the text to be used as a section label in the job posting.
<b>Description</b>	Enter content for this library entry. Content can include text and graphics, and can be formatted to enhance the presentation of your content.

## Setting Up Application Attachments

To set up types of application attachments (for example, resumes and cover letters), use the Attachment Types (HRS\_ATCHTYPE\_TBL) component.

## Page Used to Set Up Application Attachment Types

<i>Page Name</i>	<i>Definition Name</i>	<i>Usage</i>
<u>Attachment Type Setup Page</u>	HRS_ATTACHTYPE_TBL	Define types of attachments for applications.

## Understanding URL Definitions for Application Attachments

PeopleTools manages the physical storage locations of file attachments using the URL Maintenance page (**PeopleTools** > **Utilities** > **Administration** > **URLs**). The recruiting system uses two separate URL identifiers for application attachments:

- *HRS\_APP\_ATCH*: The system uses this URL identifier when uploading application attachments in Talent Acquisition Manager (on the Application Details page).
- *HRS\_APP\_ATCH\_CG*: The system uses this URL identifier when uploading application attachments in Candidate Gateway (on the My Activities page).

---

**Warning!** Both URL identifiers *must* point to the same physical storage location so that the same application attachments are visible in both Candidate Gateway and Talent Acquisition Manager.

---

Having separate URL identifiers based on the page where the application is uploaded enables you to define different file type restrictions for applicants and for recruiting users. For example, you could allow recruiters to upload any type of file while restricting applicants to specific file types such as PDF, HTM, or DOC. File type restrictions are applied only at the time the file is uploaded, so users can always view all attachments, even if they would have been prevented from uploading files of that type.

### Delivered File Type Restrictions

As delivered, the URL identifier for Talent Acquisition Manager (*HRS\_APP\_ATCH*) does not have any file type restrictions.

As delivered, the URL identifier for Candidate Gateway (*HRS\_APP\_ATCH\_CG*) uses the delivered file extension list *CG\_EXTENSION\_LIST*, which allows only files with these extensions: .doc, .docx, .odt, .pdf, .rtf, and .txt.

## Understanding Attachment Types

Attachment Types are classifications for applicant's attachments.

### Attachment Processing Types

Every attachment type is associated with a specific *processing type* that controls how the system works with that type of attachment.

These are the five processing types:

<b><i>Processing Type</i></b>	<b><i>Description</i></b>
<i>Resume</i>	Only one attachment type can be associated with this value. Both Candidate Gateway and the recruiter-facing Application Details page have specific interfaces for uploading resume attachments, and the system auto-assigns the correct attachment type to resume files. Users cannot associate the resume attachment type to files that are uploaded in the general-purpose Attachments grids.
<i>Cover Letter</i>	Only one attachment type can be associated with this value. Candidate Gateway provides a specific interface for uploading cover letters within a job application, and the system auto-assigns the correct attachment type to cover letters that are uploaded there. Users can also choose this attachment type when uploading files to the general-purpose Attachments grids.
<i>References</i>	Only one attachment type can be associated with this value. No special processing exists for reference attachments; this processing type is simply for identification.
<i>Integration Other</i> (open integration framework other)	Only one attachment type can be associated with this value. The system assigns this type to all non-resume attachments that come from third-party vendors via the Open Integration Framework.  On the Application Details page in Talent Acquisition manager, users can manually associate attachments with this attachment type. However, in Candidate Gateway, this attachment type is not shown to applicants when they choose an attachment type for a file.
<i>Other</i>	This is the only processing type that can be associated with more than one attachment type. Therefore, implementers use this value when establishing custom attachment types. Examples might include transcripts or work samples.

---

**Note:** Attachments that are uploaded to Candidate Gateway must be associated with an attachment type. In Talent Acquisition Manager, an attachment type is optional.

---

## Job Applications and Attachments

Resume attachments are always associated with specific job applications. Both Candidate Gateway and the recruiter-facing Application Details page have specific interfaces for uploading resume attachments; users cannot upload resume attachments in the general-purpose Attachments grids.

Other types of attachments can be associated with specific job applications, or they can be associated with the applicant's overall record and thus associated with all of an applicant's applications.

In Candidate Gateway, attachments that are uploaded within the guided application process are associated with the specific application. Attachments that are uploaded on the My Activities page are associated with the overall applicant record.

Talent Acquisition Manager does not provide a page for uploading attachments that are not associated with specific application. Instead, attachments are managed entirely on the [Application Details Page](#). On this page, the Attachments grid includes an **Apply to All** check box for indicating when an attachment

is associated with the overall applicant record (and thus all applications) rather than with the specific application shown on the page.

### Limits on Applicant Uploads

To prevent applicants from uploading excessive numbers of attachments, attachment types settings specify the maximum number of attachments that can be added within a job application and a separate maximum for the number of attachments that can be added outside of applications. When a limit has been reached, Candidate Gateway prevents the applicant from uploading additional files.

The system does not restrict the number of attachments that a recruiter uploads in Talent Acquisition Manager, except that each application is limited to just one resume attachment. However, any applicant-level attachments that are uploaded in Talent Acquisition Manager count towards the limit in Candidate Gateway. (Application-specific attachments that are uploaded in Talent Acquisition Manager are not relevant to the limits because an applicant is not able to modify an application that was saved in Talent Acquisition Manager.)

The Candidate Gateway attachment maximums depend on the processing type, as shown in the following table:

<i><b>Processing Type for the Attachment Type</b></i>	<i><b>Maximum Within a Job Application</b></i>	<i><b>Maximum Outside of Applications</b></i>
<i>Resume</i>	One	None
<i>Cover Letter</i>	One	Configurable
<i>Integration Other</i>	None	Unlimited
<i>Reference or Other</i>	Configurable	Configurable

### Attachment Type Setup Page

Use the Attachment Type Setup page (HRS\_ATTACHTYPE\_TBL) to define types of attachments for applications.

Navigation:

**Set Up HCM > Product Related > Recruiting > Recruiting Attachment Types > Attachment Type Setup**

This example illustrates the Attachment Types page.

### Attachment Types

Attachment Type Code 004

**Attach Details**

\*Status

\*Description

Short Description

Max Occurrences Within a Job Application

Max Occurrences Outside of Applications

\*URL Identifier  [Edit](#)

URLID RECORD://HRS\_ATTACHMENTS

\*Processing Type

<i>Field or Control</i>	<i>Description</i>
<b>Status</b>	<i>Active</i> attachment types are available for selection in both Candidate Gateway and Talent Acquisition Manager. If you want to make an attachment type unavailable in Candidate Gateway while keeping it available in Talent Acquisition Manager, enter 0 in the <b>Max Occurrences</b> fields to disallow the attachment type in Candidate Gateway.
<b>Description</b>	This description is used on the pages where applicants and recruiters upload attachments.
<b>Short Description</b>	This description is used on the <a href="#">Include Attachments Page</a> , where a user selects the types of attachments to include in a routing request.
<b>Maximum Occurrences Within a Job Application</b>	<p>Specify the maximum number of files with this attachment type that an applicant can attach to a specific job application:</p> <ul style="list-style-type: none"> <li>• If the processing type is <i>References</i> or <i>Other</i>, enter a value from 0 to 99.</li> <li>• If the processing type is <i>Resume</i> or <i>Cover Letter</i>, the maximum is 1.</li> <li>• If the processing type is <i>Integration Other</i>, the maximum is 0</li> </ul> <p>When the maximum occurrences value is zero, the applicant does not see the attachment type in the list of available attachment types. Setting the maximum occurrences to zero lets you suppress an attachment type in a specific context.</p> <p>When a recruiter enters applicant data using Talent Acquisition Manager, this limit does not apply.</p>

<b>Field or Control</b>	<b>Description</b>
<b>Maximum Occurrences Outside of Applications</b>	<p>Specify the maximum number of files with this attachment type that an applicant can upload on the My Activities page in Candidate Gateway. These attachments are not associated with individual job application. In Talent Acquisition Manager, these attachments are visible within all of the applicant's applications.</p> <ul style="list-style-type: none"> <li>• If the processing type is <i>Cover Letter</i>, <i>References</i> or <i>Other</i>, enter a value from 0 to 99.</li> <li>• If the processing type is <i>Resume</i>, the maximum is 0.</li> <li>• if the processing type is <i>Integration Other</i>, the maximum is 99, but because this processing type is reserved for attachments that are received through the Open Integration Framework, applicants cannot manually upload attachments with this processing type.</li> </ul> <p>When the maximum occurrences value is zero, the applicant does not see the attachment type in the list of available attachment types. Setting the maximum occurrences to zero lets you suppress an attachment type in a specific context.</p> <p>When a recruiter enters applicant data using Talent Acquisition Manager, this limit does not apply.</p>
<b>URL Identifier</b>	<p>Use the URL Identifier <i>HRS_APP_ATCH</i> for all application attachments.</p>
<b>Edit</b>	<p>Click the link to display the URL Maintenance page. Use the URL Maintenance page to:</p> <ul style="list-style-type: none"> <li>• Define the physical location where the system stores the attachments.</li> <li>• Restrict the files types for attachments.</li> </ul> <p>The <i>HRS_APP_ATCH</i> and <i>HRS_APP_ATCH_CG</i> URL identifiers can have different file type restrictions, but they <i>must</i> have the same physical storage location so that application attachments are visible in both Candidate Gateway and Talent Acquisition Manager.</p>
<b>URL</b>	<p>Displays the URL address (the physical storage location for the attachments) for the selected URL identifier.</p>
<b>Processing Type</b>	<p>Identifies the processing type that controls how the system works with this type of attachment.</p> <p>The only processing type that can be used for more than one attachment type is <i>Other</i>. Use this processing type to set up any new attachment types that you need.</p>



## Setting Up Contact Methods

To set up contact methods use the Contact Method Types (HRS\_CNTCT\_MTHD) component.

### Page Used to Set Up Contact Methods

<i>Page Name</i>	<i>Definition Name</i>	<i>Usage</i>
Contact Methods Page	HRS_CNTCT_MTHD	Define contact method types for reporting and classification purposes.

### Contact Methods Page

Use the Contact Methods page (HRS\_CNTCT\_MTHD) to define contact method types for reporting and classification purposes.

Navigation:

**Set Up HCM > Product Related > Recruiting > Relationship Management > Applicant Contact Method Types > Contact Methods**

This example illustrates the Contact Methods page.

The screenshot shows the 'Contact Methods' page interface. At the top, there is a title 'Contact Methods' and a navigation bar with options like 'Personalize', 'Find', 'View All', and pagination 'First 1-11 of 11 Last'. Below this is a table with two main columns: '\*Contact Method Name' and 'Short Name'. Each row represents a contact method type, such as 'Inbound Chat' with a short name of 'Chat', and 'Outbound Web' with a short name of 'Web'. To the right of each 'Short Name' cell, there are two small buttons: a blue '+' button and a grey '-' button, used for adding or removing items.

*Contact Method Name	Short Name		
Inbound Chat	Chat	+	-
Inbound Letter	Letter	+	-
Inbound Email	Email	+	-
Inbound Phone	Phone	+	-
Inbound Fax	Fax	+	-
Inbound Web	Web	+	-
Outbound Letter	Letter	+	-
Outbound Email	Email	+	-
Outbound Phone	Phone	+	-
Outbound Fax	Fax	+	-
Outbound Web	Web	+	-

<b>Field or Control</b>	<b>Description</b>
<b>Contact Method</b>	Enter a contact method description. Many forms of contact take place outside of the system; users select the contact method when manually entering information about communication with an application.

PeopleSoft delivers these contact methods. You can add as many as you like.

---

## Setting Up Interview Definitions

To set up interview definitions, use Interview Types (HRS\_INT\_LVL\_TBL), Interview Evaluation Category (HRS\_INT\_CTG\_TBL), and Interview Evaluation Ratings (HRS\_INT\_RTG\_TBL) components.

### Pages Used to Set Up Interview Definitions

<b>Page Name</b>	<b>Definition Name</b>	<b>Usage</b>
<a href="#">Interview Types Page</a>	HRS_INT_LVL_TBL	Create interview types.
<a href="#">Interview Evaluation Category Page</a>	HRS_INT_CTG_TBL	Create interview evaluation categories.
<a href="#">Interview Evaluation Ratings Page</a>	HRS_INT_RTG_TBL	Create interview ratings.

## Understanding Interview Definitions

Set up these three types of definitions for interviews:

- Interview types categorize the interview.

Example of interview types might be in house, campus, and phone.

- Interview categories define the areas in which you want to evaluate applicants.

PeopleSoft delivers four categories: Communication Skills, Education/Training, Work Experience, and Technical skills. You can add as many categories as necessary.

- Interview ratings define how you rate the applicant within the category and associate a score to that rating.

PeopleSoft delivers three ratings: Excellent, which has a score of 2; Average, which has a score of 1; and Not Qualified, which has a score of 0. You can add as many ratings as necessary.

After you set up these tables, you can create interview evaluation templates. Interview evaluation templates enable you to group categories and ratings so that you can create interview evaluations that target a specific job opening or group of job openings.

See [Setting Up Interview Evaluation Templates](#).

## Interview Types Page

Use the Interview Types page (HRS\_INT\_LVL\_TBL) to create interview types.

Navigation:

**Set Up HCM > Product Related > Recruiting > Screening > Interview Types > Interview Types**

This example illustrates the Interview Types page.

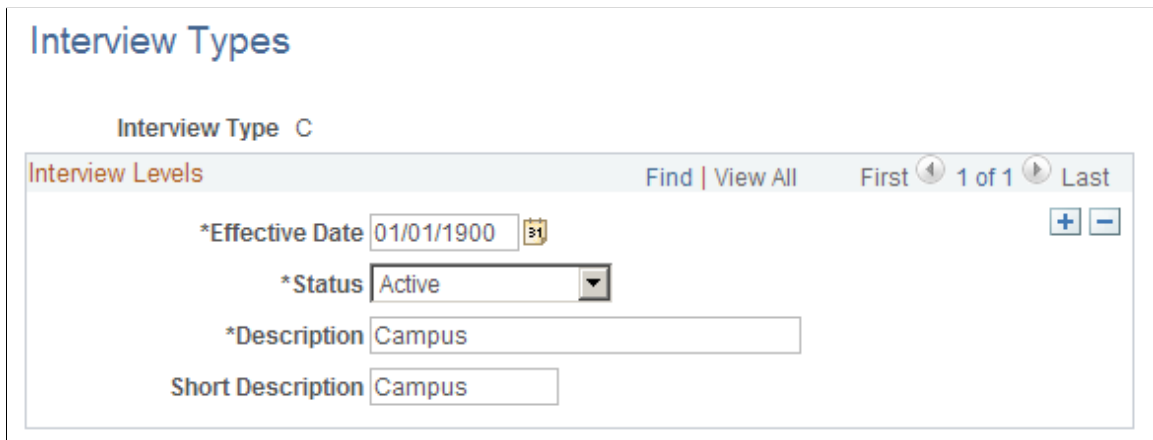

The screenshot shows the 'Interview Types' page with the following details:

- Page Title:** Interview Types
- Section:** Interview Type C
- Table Header:** Interview Levels
- Navigation:** Find | View All, First 1 of 1 Last
- Fields:**
  - \*Effective Date: 01/01/1900 (with a calendar icon)
  - \*Status: Active (dropdown menu)
  - \*Description: Campus
  - Short Description: Campus

Enter a description that describes how an interview may be conducted. This description is used when you schedule an interview.

## Interview Evaluation Category Page

Use the Interview Evaluation Category page (HRS\_INT\_CTG\_TBL) to create interview evaluation categories.

Navigation:

**Set Up HCM > Product Related > Recruiting > Screening > Interview Evaluation Category > Interview Evaluation Category**

This example illustrates the Interview Evaluation Category page.

### Interview Evaluation Category

Evaluation Category 1

Interview Evaluation Category
Find | View All
First ◀ 1 of 1 ▶ Last

\*Effective Date  + -

\*Status

\*Description

Short Description

## Interview Evaluation Ratings Page

Use the Interview Evaluation Ratings page (HRS\_INT\_RTG\_TBL) to create interview ratings.

Navigation:

**Set Up HCM > Product Related > Recruiting > Screening > Interview Evaluation Ratings > Interview Evaluation Ratings**

This example illustrates the Interview Evaluation Ratings page.

### Interview Evaluation Ratings

Evaluation Rating 1

Interview Evaluation Ratings
Find | View All
First ◀ 1 of 1 ▶ Last

Effective Date  + -

\*Status

\*Description

Short Description

Score

<i>Field or Control</i>	<i>Description</i>
<b>Score</b>	Enter a score for this evaluation rating.

## Setting Up Job Offer Components

To set up job offers, use the Offer Component Type (HRS\_OFF\_TYPE\_TBL) and Offer Component (HRS\_OFF\_CMPNT\_TBL) components.

### Pages Used to Set Up Job Offers

<i>Page Name</i>	<i>Definition Name</i>	<i>Usage</i>
<a href="#">Job Offer Component Type Page</a>	HRS_OFF_TYPE_TBL	Create the job offer component types that you use to group offer components.
<a href="#">Job Offer Component Page</a>	HRS_OFF_CMPNT_TBL	Enter job offer component information.

### Understanding Job Offer Setup

This overview discusses job offer setup.

#### Components of Pay

Often, the compensation package in a job offer includes multiple elements, of which the base salary is just one component. You might offer applicants a bonus, stock options, or car allowances in addition to a salary. To track all elements of job offers, you need to set up job offer components and job offer component types for your organization.

Use job offer component types to group similar offer components. For example, you might have a type for the salary job offer components. Hiring managers, recruiters, and recruiting administrators select from the predefined components when entering applicant job offers.

See [Creating Job Offers](#).

#### Attachments for Online Job Offers

When you post a job offer to Candidate Gateway, you can post not only the offer letter, but also additional relevant attachments. These can be applicant-specific, or they can be general-purpose documents such as proof of citizenship forms or information related to your organization's employment policies.

To define the organization-level attachments that recruiting users will be able to add to job offers, you use the attachments framework that is a common component for all PeopleSoft HCM applications.

The attachments framework categorizes attachments as one of three types:

- *Attachment*: an electronic file such as a PDF document.
- *URL*: a link to a file or web sites
- *Document definition*: a placeholder for a file attachment, URL, or note that the person creating the job offer will add on the fly.

To set up job offer attachments using the attachments framework:

1. Access the Define Attachments page (**Set Up HCM > Common Definitions > Attachments > Define Attachments**) and create the attachment.

Use this page to upload a file, enter a URL, or create a document definition, depending on the type of attachment you are defining.

You also use this page to enter an attachment description and define which roles can access the attachment.

2. Access the Maintain Definitions page (**Set Up HCM > Common Definitions > Attachments > Maintain Definitions**) for the object owner HRAM, and associate individual attachments with specific key values such as specific business units or companies.

For example, if you upload country-specific proof of citizenship forms, then you use this page to associate each uploaded file with the correct country. This ensures that a recruiter who is selecting attachments to add to the offer will be able to access only attachments that are appropriate for the specific job opening.

See “Configuring and Working With Attachments” (Application Fundamentals).

## Job Offer Component Type Page

Use the Offer Component Type page (HRS\_OFF\_TYPE\_TBL) to create the job offer component types that you use to group offer components.

Navigation:

**Set Up HCM > Product Related > Recruiting > Job Offer Component Type > Job Offer Component Type**

This example illustrates the Job Offer Component Type page.

The screenshot shows the 'Offer Component Type' page for Offer Type K000001. The page includes a table with one row and several input fields. The table has columns for 'Offer Component Type', 'Find', 'View All', 'First', '1 of 1', and 'Last'. The input fields are: '\*Effective Date' (01/01/1900), '\*Status' (Active), '\*Description' (Base), 'Short Description' (Base), 'Role Name' (empty), and a checked 'Base Salary Indicator' checkbox.

<b>Field or Control</b>	<b>Description</b>
<b>Role Name</b>	<p>Select the role that is responsible for administering the offer component type. For example, if you create a component type for stock options, you would link this to the stock administrator role.</p> <p>If you set up email workflow, the system sends an email to the person with the selected role to notify that person of new hires.</p> <p>See <i>PeopleTools: Security Administration</i></p>
<b>Base Salary Indicator</b>	<p>Select this check box if the component type forms part of the base salary. The system uses this check box to calculate the total base salary. When a job offer is entered, the system checks whether the base salary exceeds the maximum salary grade range for the job. You define the salary grades for a job opening on the Salary Grades page.</p>

## Job Offer Component Page

Use the Job Offer Component page (HRS\_OFF\_CMPNT\_TBL) to enter job offer component information.

Navigation:

**Set Up HCM > Product Related > Recruiting > Job Offer Component > Job Offer Component**

This example illustrates the Job Offer Component page.

### Offer Component

Offer Component K000001

Offer Component
Find | View All
First 1 of 1 Last

\*Effective Date

\*Status

\*Description

Short Description

\*Offer Type

Payment Mode

Frequency

Currency Code  US Dollar

<b>Field or Control</b>	<b>Description</b>
<b>Offer Type</b>	Select the type of offer from the available component types. Define component types on the Offer Component Types page.
<b>Payment Mode</b>	Select <i>Cash, Leaves, Meal Vouchers, Non Cash, or Stock Options</i> to indicate the type of compensation.
<b>Frequency</b>	Enter the frequency at which this component will be paid.
<b>Currency Code</b>	More monetary component of pay, enter the currency that will be used to pay this component.

## Setting Up Online Job Offer Attachments

Use the PeopleSoft HCM attachment framework to create a library of job offer attachments that recruiters can associate with online job offers.

### Pages Used to Set Up Online Job Offer Attachments

**Note:** Refer to the documentation for “Configuring and Working With Attachments” (Application Fundamentals) for complete information on using the common attachment framework to create an attachment library.

<b>Page Name</b>	<b>Definition Name</b>	<b>Usage</b>
“Define Attachments Page” (Application Fundamentals)	HR_ATT_CNFG	<p>Create an organizational attachment and list the roles that have access to the attachment.</p> <p>When you create the attachment, you identify it as a file attachment or a URL, and you either upload the file attachment or enter the URL.</p>
“Maintain Definitions Page” (Application Fundamentals)	HR_ATT_DEFN	<p>Establish the contexts in which attachments are to be available (for example, different business units or departments might use different attachments), and associate specific attachments with each context.</p> <hr/> <p><b>Note:</b> To configure recruiting attachments, access this page for the <i>HRAM</i> owner ID.</p>



<b>Page Name</b>	<b>Definition Name</b>	<b>Usage</b>
<u>Job Offer Attachment Setup Page</u>	HRS_ATCH_SETUP	Identify a custom application class to control which attachment framework attachments are visible to a recruiter who is adding attachments to a job offer.

## Understanding Online Job Offer Attachments

When you enable online job offers (posting job offers to Candidate Gateway), the system provides the ability to post attachments with the job offer.

Any offer letter that a recruiter generates is automatically added to the offer's list of attachments, but the recruiter can also add additional attachments. A standard attachment interface enables the recruiter to attach local files. Additionally, the PeopleSoft HCM attachment framework enables recruiters to select attachments from a predefined library of job offer attachments. On the job offer pages, these are referred to as *organizational attachments*.

See [Creating Job Offers](#).

### Benefits of the Common Attachments Framework

Using the common attachment framework enables you to:

- Ensure that recruiters have access to current versions of standard documents.
- Enable recruiters to pick from a list of appropriate documents rather than having to remember what documents are available.
- Define different lists of attachments for different contexts, such as different business units, regulatory regions, or job codes.

### Types of Documents in the Attachment Framework

Generally, we think of “attachments” as file attachments. However, the attachment framework supports three types of objects. Only two of these are commonly used as job offer attachments:

- File attachments.
- URLs (links).

The third object supported by the attachment framework is known as a document definition. Document definitions are *not* typically used in recruiting. They are empty placeholders that are used to collect specified types of information from self-service users. (For example, the self-service process for applying for a medical leave might include a document definition for a completed medical form, which the employee is responsible for uploading.)

If you were to create a document definition for a job offer, the recruiter (and not the applicant) could put file attachments, URLs, or text notes into the placeholder. But because the recruiter can add files attachments directly to the offer and can incorporate URLs and text notes into the offer letter, using document definitions for this functionality normally adds complexity without providing any benefit.

Note that the applicant who views the offer in Candidate Gateway can see any files, URLs, or notes that a recruiter puts into a document definition, but the applicant cannot use the document definition to add information to the system. Instead, the online job offer page provides a separate mechanism that the applicant uses to upload completed forms or send messages to the recruiter.

## Establishing a Context-Sensitive Attachment Library

Refer to the documentation for “Configuring and Working With Attachments” (Application Fundamentals) for complete information on using the common attachment framework to create an attachment library. The key steps for defining job offer attachments are as follows:

1. Go to the Define Attachments page (**Set Up HCM > Common Definitions > Attachments > Define Attachments**) to create the attachment and to list the roles that have access to the attachment.

When you create the attachment, you identify it as a file attachment or a URL, and you either upload the file attachment or enter the URL.

2. Go to the Maintain Definitions page (**Set Up HCM > Common Definitions > Attachments > Maintain Definitions**) and access the record for the *HRAM* (HR Applicant Manager) owner ID.

The owner ID controls which PeopleSoft HCM business process can access the attachment. The *HRAM* owner ID identifies attachments that are available for job offers.

3. Establish the contexts in which attachments are to be available, and associate specific attachments with each context.

As delivered, the *HRAM* owner ID has context keys for Business Unit, Company, Department SetID, Department, Job Code SetID, Job Code, Job Family, Position Number, Location SetID, Location Code, and Regulatory Region. The attachment framework enables you to modify the context keys to suit your business requirements.

This illustration shows the Maintain Definitions page for the *HRAM* owner ID. In this illustration, the All Values check box is selected for all of the context keys, so the listed attachments will be available for all job openings, regardless of the business unit, company, and so forth.

**Maintain Definitions**

Object Owner ID *HRAM*  
Sub Id *JOFF*

Definition Find | View All First 1 of 1 Last

\*Effective Date 01/01/2000 \*Status Active

Context Find | View All First 1 of 1 Last

\*Sequence Number 1

**Context Keys** Personalize | Find | View All | 1-11 of 11 Last

Key Field	Key Value	Key Date	Key Number	All values
1 Business Unit				<input checked="" type="checkbox"/>
2 Company				<input checked="" type="checkbox"/>
3 Department SetID				<input checked="" type="checkbox"/>
4 Department				<input checked="" type="checkbox"/>
5 Job Code SetID				<input checked="" type="checkbox"/>
6 Job Code				<input checked="" type="checkbox"/>
7 Job Family				<input checked="" type="checkbox"/>
8 Position Number				<input checked="" type="checkbox"/>
9 Location SetID				<input checked="" type="checkbox"/>
10 Location Code				<input checked="" type="checkbox"/>
11 Regulatory Region				<input checked="" type="checkbox"/>

**Attachments** Personalize | Find | View All | 1-4 of 4 Last

*Configuration ID	*Sequence	*Group Box
1 HRS_BENE_LNK	1	None
2 HRS_DRUGTEST_LNK	2	None

To add attachments that are available for just one specific business unit, you would create an additional row in the Context scroll area, deselect the All Values check box for the *Business Unit* key field, and enter the specific business unit for the context. You would then add the business unit-specific attachments to the Attachments grid.

See “Configuring and Working With Attachments” (Application Fundamentals).

## Job Offer Attachment Setup Page

Use the Job Offer Attachment Setup page (*HRS\_ATCH\_SETUP*) to identify a custom application class to control which attachment framework attachments are visible to a recruiter who is adding attachments to a job offer.

Navigation:

**Set Up HCM > Product Related > Recruiting > Job Offer Attachment Setup > Job Offer Attachment Setup**

This example illustrates the Job Offer Attachment Setup page.

### Job Offer Attachment Setup

**Attachment Application Class**

Application Class Path

Application Class ID

Method Name

<i>Field or Control</i>	<i>Description</i>
<p><b>Application Class Path, Method Name, and Method Name</b></p>	<p>The method identified by these three fields here is called from the page activate of the Organizational Attachments page (HRS_OFF_SELATC_SEC) in the Job Offer component. It determines which job offer attachments are displayed on the Organizational Attachments page if a match is found for the context keys passed in.</p> <p>See <a href="#">Organizational Level Documents Page</a>.</p> <p>To invoke custom processing, clone the delivered method, then modify the it according to your needs. Save the customized application class as a new application class within HRS_APPLICANT_TRACKING, then enter the new method name on this page.</p>

## Setting Up the Data Transfer to HR

The Manage Hire Setup page enables you to select the information you want to transfer from the recruiting tables to the HR tables. To define the data to transfer, use the Data Transfer to HR (HRS\_MNG\_HIR\_STP) and Hire Notification (HR\_HIRE\_NOTIF) components. When you hire an applicant, the system uses the information defined here to determine the data to transfer.

### Page Used to Set Up the Data Transfer to HR

<i>Page Name</i>	<i>Definition Name</i>	<i>Usage</i>
<a href="#">Manage Hire Setup Page</a>	HRS_MNG_HIR_STP	Define the recruiting data you want transferred to the HR database when the applicant is hired.

### Related Links

[Hiring Applicants](#)

## Manage Hire Setup Page

Use the Manage Hire Setup page (HRS\_MNG\_HIR\_STP) to define the recruiting data you want transferred to the HR database when the applicant is hired.

Navigation:

**Set Up HCM > Product Related > Recruiting > Data Transfer to HR > Manage Hire Setup**

This example illustrates the Person tab of the Manage Hire Setup page.

### Manage Hire Setup

This setup will determine what information is sent from the applicant's recruitment record to their employee record in Human Resources. Select the checkbox if the information should be sent to Human Resources.

Type of Hire Hire

Person

Profile

Other

Description	Transfer To HR
Person	<input checked="" type="checkbox"/>
National ID	<input checked="" type="checkbox"/>
Addresses	<input checked="" type="checkbox"/>
Diversity	<input checked="" type="checkbox"/>
Person Names	<input checked="" type="checkbox"/>
Offer Letter	<input checked="" type="checkbox"/>
Email Addresses	<input checked="" type="checkbox"/>
Phones	<input checked="" type="checkbox"/>

<b>Field or Control</b>	<b>Description</b>
<b>Type of Hire</b>	Select the type of hire you are performing. Your choices are: <ul style="list-style-type: none"> <li>• <i>Add Concurrent Job</i></li> <li>• <i>Add Contingent Worker</i></li> <li>• <i>Hire</i></li> <li>• <i>Rehire</i></li> <li>• <i>Transfer</i></li> </ul>

<b>Field or Control</b>	<b>Description</b>
<b>Transfer to HR</b> (transfer to human resources)	<p>Select the check box next to the information that you want transferred to the HR database for this type of hire.</p> <p>On the Person tab, available options include personal information such as name, national ID, addresses, email addresses, and phone numbers.</p> <p>There is also a check box to select if you want users to be able to send offer letters along with other applicant information. Specifically, selecting the <b>Offer Letter</b> check box causes the system to display a <b>Send Offer Letter to HR</b> check box on the Prepare for Hire page. Users must explicitly select that check box (which is deselected by default) to include the offer letter in the message to the HR system.</p> <hr/> <p><b>Important!</b> If you select the <b>Offer Letter</b> check box the system does <i>not</i> automatically send the letter. Instead, the system gives users the option of sending the offer letter when preparing specific applicants for hire.</p> <hr/> <p>See <a href="#">Prepare For Hire Page</a>.</p>

## Profile

Select the **Profile** tab.

This example illustrates the Profile tab of the Manage Hire Setup page.

## Manage Hire Setup

This setup will determine what information is sent from the applicant's recruitment record to their employee record in Human Resources. Select the checkbox if the information should be sent to Human Resources.

Type of Hire Hire

Person
**Profile**
Other

Profile Types	
Description	Transfer To HR
Areas of Study	<input checked="" type="checkbox"/>
Competencies	<input checked="" type="checkbox"/>
Degrees	<input checked="" type="checkbox"/>
School Education	<input checked="" type="checkbox"/>
Educ and Govt Special Projects	<input checked="" type="checkbox"/>
Elements	<input checked="" type="checkbox"/>
Geographic Preferences	<input checked="" type="checkbox"/>
Honors and Awards	<input checked="" type="checkbox"/>
International Preferences	<input checked="" type="checkbox"/>
Licenses and Certifications	<input checked="" type="checkbox"/>
Language Skills	<input checked="" type="checkbox"/>
Location	<input checked="" type="checkbox"/>
Location Preferences	<input checked="" type="checkbox"/>
Memberships	<input checked="" type="checkbox"/>
Responsibilities	<input checked="" type="checkbox"/>

The Profile tab lists profile content types that have been set up for applicants. The specific content types depend on your configuration, but examples might include competencies, licenses and certificates, and language skills.

Select the check boxes for the types of profile information that the system is to include when sending the applicant's data to the human resources system.

### Other

Select the **Other** tab.

This example illustrates the Other tab of the Manage Hire Setup page.

## Manage Hire Setup

This setup will determine what information is sent from the applicant's recruitment record to their employee record in Human Resources. Select the checkbox if the information should be sent to Human Resources.

Type of Hire Hire

Person
Profile
Other

Description	Transfer To HR
Eligibility/Identity	<input checked="" type="checkbox"/>
Identification Data	<input checked="" type="checkbox"/>
Prior Work Experience	<input checked="" type="checkbox"/>
Accomodation	<input checked="" type="checkbox"/>
Training	<input checked="" type="checkbox"/>
Contract Data	<input checked="" type="checkbox"/>
Appl/Person Assignment Chklist	<input checked="" type="checkbox"/>
Applicant/Employment Contracts	<input checked="" type="checkbox"/>
Bank Accounts	<input checked="" type="checkbox"/>
Disabilities	<input checked="" type="checkbox"/>

The Other tab lists additional types of applicant information that you can send to the human resources system, including eligibility/identity data, disability and accommodation data, checklists, employment contracts, and bank accounts.

Select the check boxes for the types of information that the system is to include when sending the applicant's data to the human resources system.

---

**Note:** In a federalized database, disability-related fields are not transferred to the HR system.

---



# Setting Up Flexible Processes

---

## Understanding Flexible Processes

Flexible processing refers to configuration options that let you set up role-based access to certain recruiting options. Different flexible process definitions can be applied based on a job opening's business unit, job family, job code, department, and primary recruiting location. Limiting recruiters and hiring managers to context-appropriate and role-appropriate options improves usability and streamlines the recruiting process.

---

**Note:** Flexible processing restrictions do not apply to recruiting administrators.

---

### Flexible Process Types

You can configure flexible processing rules for these two processes:

- Job Creation Process

A flexible job creation process enables you to hide fields for job openings that are not yet open. This includes newly created job openings that have not yet been saved as well as jobs in Draft status. In general, this process is most useful for limiting which fields hiring managers see when they need to supply or review data for a new job opening. Showing the hiring managers only the relevant fields, without the distraction of the full set of job opening fields, reduces confusion and streamlines the hiring manager's tasks.

- Recruiting Process

Flexible recruiting processes include two types of rules:

- Hide specified recruiting actions based on the applicant's disposition. For example, if recruiters are the only users who should prepare job offers, you can hide the Prepare Job Offer action from hiring managers. You can also hide specific actions from both recruiters and hiring managers if those actions are not part of your business process.
- Present a limited set of successor dispositions based on the applicant's current disposition. This limitation applies when a user is manually updating an applicant's disposition using the Edit Disposition action.

When setting up successor dispositions, the settings on the [Status Successors Page](#) affect which dispositions you can configure as valid successors. The flexible process settings (which actually prevent invalid transitions) then take precedence over the general status successor settings (which simply warn users when a transition is invalid).

### Flexible Process Implementation

To implement flexible processing rules:

1. Create job creation process definitions.

Use the [Job Creation Process Page](#) and the [Configure Field Visibility Page](#).

2. Create recruiting process definitions.

Use the [Recruiting Process Page](#), the [Dispositions and Roles Page](#), and the [Actions and Roles Page](#).

3. Create a flexible process template that associates your definitions with specific job criteria.

Use the [Flexible Process Template Page](#).

4. Create a flexible process group that contains all of the flexible process templates that you want to associate with a single recruitment template.

Use the [Flexible Template Group Page](#).

5. Associate the flexible template group with a recruitment template.

Use the [Recruitment Template Page](#).

6. (Optional) Select default flexible processes to use when a job opening's recruitment template does not find a flexible process based on the job opening data.

Use the [Recruiting Installation - General Page](#)

If you do not specify defaults, job openings that do not use flexible processing are unrestricted. Specifically:

- When no job creation process is in effect, the system displays all job opening fields to all users during the job creation process.
- When no recruiting process is in effect, the system does not restrict access to actions or to dispositions.

This diagram shows the architecture for implementing flexible processing. A job creation process and a recruiting process are associated with a flexible template. One or more flexible templates are associated with a single flexible template group. The flexible template group is associated with a recruitment template. When a job opening uses a particular recruitment template, it also uses the associated flexible process rules.

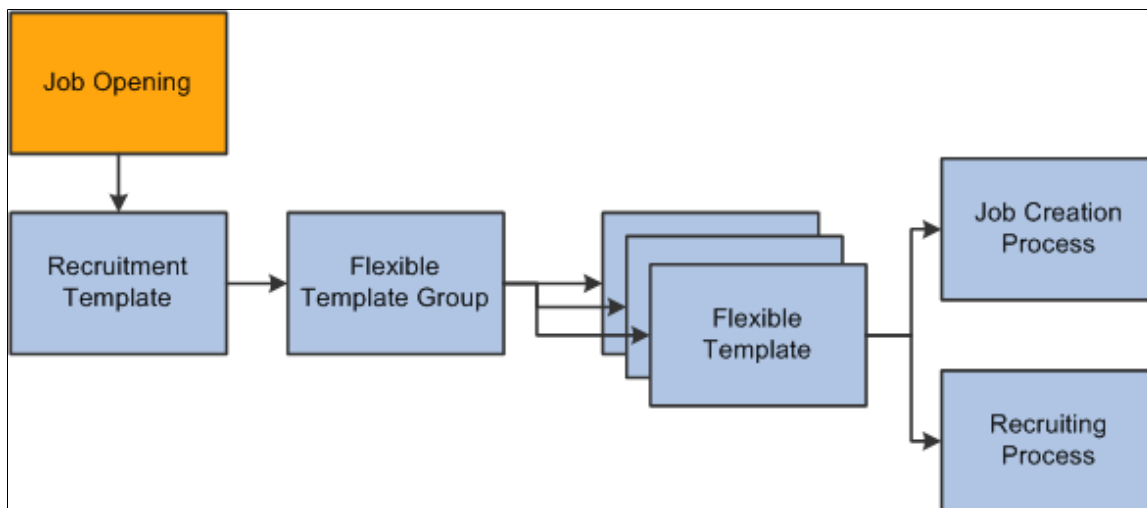

## Setting Up Flexible Job Creation Processes

To set up job creation processes, use the Job Creation Process (HRS\_JCP\_DEFN) component.

### Pages Used to Set Up Job Creation Processes

<i>Page Name</i>	<i>Definition Name</i>	<i>Usage</i>
<u>Job Creation Process Page</u>	HRS_JCP_DEFN	Set up a process that controls which job opening fields are visible to users with different recruiting roles types.
<u>Configure Field Visibility Page</u> (The page name is Modify Field Visibility when you access existing settings.)	HRS_JCP_FLD_CONFIG	Define detailed field visibility settings for a single recruiting role type.

### Understanding the Job Creation Process

A robust set of job opening fields is important for defining job characteristics and qualifications, but users who do not need to interact with all of the available fields can be overwhelmed or confused by seeing a lot of extra fields that are not relevant to them at this point. The job creation process enables you to configure which job opening fields are visible to which recruiting roles during the job creation process. This configuration allows managers to focus on the information that they are responsible for without

being distracted or confused by fields that a recruiter will complete. When the job opening is no longer in draft status, all users including managers can view the complete job opening data.

**Note:** The job creation process should not be considered a security tool. Fields that are hidden from specified users during the job creation process become visible when the job is no longer in draft status. Also, fields are hidden only from users with specified roles, and a user with a role that is not specifically configured can always see all job opening fields.

### Example of the Job Creation Process

The following illustrations show how a job creation can simplify a hiring manager’s experience when the manager must enter a limited amount of data in a draft job opening.

This example shows the first few fields of a draft job opening as a hiring manager would see it without the benefit of a flexible job creation process. Many more fields appear after the ones shown here.

Job Opening

Save and Open Save as Draft Delete | 
 [Job Opening List](#) | [Notification](#) | [Next Job Opening](#)

Job Opening ID 300277	Status 005 Draft
Job Posting Title Clerk-Data Entry	Business Unit GBIBU (Global Business Institute BU)
Job Code 290030 (Clerk-Data Entry)	Job Family KCLERK (Clerical)

Job Details

Qualifications

Screening

Job Postings

Hiring Team

Opening Information ?

Job Opening Type Standard Requisition

Created By  Betty Locherty

Created  BT

---

\*Openings to Fill Limited Number of Openings

Target Openings

Available Openings

---

Establishment ID

Company  Global Business Institute

---

Status Code 005 Draft

Status Reason

Status Date 11/30/2012

---

Desired Start Date

Encumbrance Date

Projected Fill Date

Date Authorized

This example shows a draft job opening as a hiring manager would see it when the flexible job creation process shows hiring managers a small subset of the job opening fields. Note that the flexible recruiting process does not hide tabs even when the user cannot see any fields on a tab.

**Job Opening**

Save and Open | Save as Draft | Delete | Job Opening List | Notification | Next Job Opening

Job Opening ID 300277 | Status 005 Draft  
 Job Posting Title Clerk-Data Entry | Business Unit GBIBU (Global Business Institute BU)  
 Job Code 290030 (Clerk-Data Entry) | Job Family KCLERK (Clerical)

Job Details | Qualifications | Screening | Job Postings | Hiring Team

Opening Information ?

Job Opening Type Standard Requisition

\*Openings to Fill Limited Number of Openings  
 Target Openings 1

Status Code 005 Draft  
 Status Reason  
 Status Date 11/30/2012

Desired Start Date

Locations ?

*Location	Location Description	Primary Location
		<input type="checkbox"/>

Add Location

## Job Creation Process Page

Use the Job Creation Process page (HRS\_JCP\_DEFN) to set up a process that controls which job opening fields are visible to users with different recruiting roles.

Navigation:

**Set Up HCM > Product Related > Flexible Processes > Job Creation Process > Job Creation Process**

This example illustrates the Job Creation Process page.

**Job Creation Process**

Job Creation Process ID 1000

\*Description Job Creation | Short Description Job Create  
 \*Status Inactive | Status Date 01/01/1900

Field Visibility of Recruiting Roles ?

*Priority	*Recruiting Role Type		
1	Hiring Manager	Modify Field Visibility	+ -
2	Recruiter	Modify Field Visibility	+ -

<b>Field or Control</b>	<b>Description</b>
<b>Status and Status Date</b>	Indicate whether the definition is <i>Active</i> or <i>Inactive</i> , and enter the date that the status was assigned. Only active definitions are available for selection in flexible process templates. (However, an inactive job creation process is still used by any flexible process templates that it is already associated with.)

## Field Visibility of Recruiting Roles

<b>Field or Control</b>	<b>Description</b>
<b>Priority</b>	<p>Enter a priority to control which role's settings to use when a person has more than one recruiting role type.</p> <p>Lower numbers have higher priority. For example, if you give the Recruiter role priority 1, and you give the Hiring Manager priority 2, then a user who has both roles will use the settings associated with the Recruiter role.</p>
<b>Recruiting Role Type</b>	<p>Create a row for each recruiting role type that you will associate with field visibility settings.</p> <p>Recruiting role types are functional groups of PeopleTools roles such as Recruiters and Hiring Managers. Use the <a href="#">Recruiting Roles Page</a> to choose which PeopleTools roles belong to each recruiting role type.</p> <p>The drop-down list box shows only recruiting role types that are associated with at least one PeopleTools role. The list does not include the Recruitment Administrator role type because administrators are never subject to flexible process restrictions.</p> <p>Users without any of the roles you specify will not be subject to flexible process restrictions. For example, if you create a row for hiring managers so that they see only a subset of job opening fields, but you do not create a row for recruiters, then recruiters who are not also hiring managers will see all of the job opening fields. If you want recruiters who are also hiring managers to see all fields, you should also create a row for the recruiter role type.</p>
<b>Configure Field Visibility and Modify Field Visibility</b>	<p>Click this link to access the page where you configure field visibility for a recruiting role type.</p> <p>For recruiting role types that do not yet have field visibility settings, the link text and the page name are <b>Configure Field Visibility</b>. After you save field visibility settings, the link text and the page name are <b>Modify Field Visibility</b>.</p>

## Configure Field Visibility Page

Use the Configure Field Visibility page (HRS\_JCP\_FLD\_CONFIG) to define detailed field visibility settings for a single recruiting role type.

Navigation:

On the Job Creation Process page, click the **Configure Field Visibility** link for a role type that has not yet been configured, or click the **Modify Field Visibility** link for a role type that was previously configured.

This is the first of three examples illustrating the Configure Field Visibility page.

When you access this page, you initially see only the first of six group of fields. You can scroll through the groups, or, to expand the page so that all sections are visible (as in these examples), click the View All link.

**Modify Field Visibility** New Window | Help | Personalize Page

Job Creation Process ID 1000 Job Creation  
 Recruiting Role Type Hiring Manager

Visible Fields 1 of 6 | [View All](#)

Job Opening Section 1. Job Opening Information

<input checked="" type="checkbox"/> Add Location	<input type="checkbox"/> Created By	<input type="checkbox"/> Created
<input checked="" type="checkbox"/> Openings to Fill	<input type="checkbox"/> Add Recruiting Location	<input checked="" type="checkbox"/> Target Openings
<input type="checkbox"/> Available Openings	<input type="checkbox"/> Establishment ID	<input type="checkbox"/> Business Unit
<input type="checkbox"/> Job Code	<input type="checkbox"/> Company	<input type="checkbox"/> Department
<input checked="" type="checkbox"/> Desired Start Date	<input type="checkbox"/> Encumbrance Date	<input type="checkbox"/> Projected Fill Date
<input type="checkbox"/> Date Authorized	<input type="checkbox"/> Referral Program ID	<input type="checkbox"/> Recruitment Contact
<input type="checkbox"/> Add Position	<input type="checkbox"/> Add Employee	

[Select All](#) [Deselect All](#)

This is the second of three examples illustrating the Configure Field Visibility page.

**Modify Field Visibility**

Job Creation Process ID 1000 Job Creation  
 Recruiting Role Type Hiring Manager

Visible Fields 2 of 6 | [View All](#)

Job Opening Section 2. Profile Combination

Add a Profile

[Select All](#) [Deselect All](#)

This is the third of three examples illustrating the Configure Field Visibility page.

Visible Fields ? 3 of 6 View All

Job Opening Section 3. Additional Job Details

Add Additional Jobs  Copy Primary Qualifications

**Staffing Information**

Region  Schedule Type  Regular/Temporary  
 Begin Date  End Date  Shift  
 Hours  Work Period  Travel Percentage

**Salary Information**

Salary Admin Plan  Job Grade and Step  Salary Range

**Screening Questions**

Add Employment Question  Add Skills Question

**Applicant Screening**

Max Total Points  Must Pass Previous Levels  Add Screening Option

[Select All](#) [Deselect All](#)

---

**Note:** (USF) Additional fields are available for configuration in a US Federal system.

---

This page includes six sections, each with check boxes that represent fields or grids for a particular area of the Create Job Opening page. Select a check box to make the field or grid available to users with the specified recruiting role type.

---

**Note:** A Job Opening template that controls which sections appear in the job opening. If a section is not included in the job opening, then the fields in that section will not appear, regardless of how the flexible job creation process is defined.

---

## Understanding Field Visibility for Grids

The Configure Field Visibility page uses a single check box to represent grids on the Create Job Opening page. The labels for these check boxes include the word *Add* before the grid name. When you make a grid available, users can add and delete grid rows, and they can access any related detail page to modify the detail data.

For example, the Competencies grid is represented by the **Add Competencies** check box. Selecting that check box enables users with the specified role type to interact fully with the Competencies grid. Users can add competencies to the job opening and remove competencies from the job opening. They can also click the links for a single competency to access the Add Competency page and modify information about the competency.



## Job Opening Sections

<b>Field or Control</b>	<b>Description</b>
<p><b>Section 1: Job Opening Information</b></p>	<p>This section includes fields and grids from the <b>Opening Information</b> group box on the Create Job Opening page.</p> <p>This section does not include check boxes for certain fields, including:</p> <ul style="list-style-type: none"> <li>• The Job Opening ID and Job Opening Type, which are always visible and never editable.</li> <li>• The Template ID field, which is visible only to recruiting administrators.</li> <li>• The Status Code, Status Reason, and Status Date fields.</li> <li>• The Job Family field, which is visible only if your template segmenting type is Job Family, in which case this field is always visible and never editable.</li> </ul> <hr/> <p><b>Note:</b> If you display the Business Unit, Job Code, and Department fields and the Recruiting Locations grid, users can make changes that affect which flexible process template governs the job opening. However, the system does not apply the new template until the next time the Job Opening page is opened.</p> <hr/>
<p><b>Section 2: Profile Combination</b></p>	<p>This section has a single check box that controls access to the Profile Combination grid, which displays the profiles whose content items were copied into the job opening.</p>

<b>Field or Control</b>	<b>Description</b>
<p><b>Section 3: Additional Job Details</b></p>	<p>This section includes check boxes to control the fields and grids from the Staffing Information, Salary Information, Screening Questions, and Applicant Screening group boxes on the job opening page. These check boxes have the following specialized processing:</p> <ul style="list-style-type: none"> <li>• The <b>Job Grade and Step</b> check box controls the following fields: <b>From Grade, From Step, To Grade, and To Step.</b></li> <li>• The <b>Salary Range</b> check box controls the following fields: <b>Salary Range From, Salary Range To, Pay Frequency, and Currency</b> fields. In US Federal implementations, it also controls the <b>PATCOB Code</b> field.</li> <li>• (USF) The <b>Competitive Ranking and Non-Competitive Ranking</b> check boxes control all fields in the <b>Competitive and Non-Competitive</b> group boxes in the <b>Applicant Screening</b> section of the job opening.</li> </ul> <p>If the <b>Allow Multiple Jobs/Positions</b> option is activated in the Recruiting Installation component, this section also includes two additional check boxes:</p> <ul style="list-style-type: none"> <li>• <b>Add Additional Jobs</b> controls whether users can add or delete job codes.</li> <li>• <b>Copy Primary Qualifications</b> controls access to the <b>Copy Qualifications from Primary Job Code</b> button.</li> </ul>
<p><b>Section 4: Additional Profile Details</b></p>	<p>This section includes check boxes for the profile content types that are available for use in job openings. For more information about profile content types, refer to <a href="#">Configuring Profiles for Recruiting</a></p>
<p><b>Section 5: Assignments</b></p>	<p>This section includes check boxes for the hiring team grids in the job opening. For example, the <b>Add Recruiter</b> and <b>Add Hiring Manager</b> check boxes control access to the <b>Recruiters</b> and <b>Hiring Managers</b> grids.</p> <p>There are separate check boxes for controlling access to the buttons that enable users to add entire teams to these grids. For example, the <b>Add Recruiter Team</b> check box controls the availability of the <b>Add Recruiter Team</b> button on the job opening</p>

<i>Field or Control</i>	<i>Description</i>
<b>Section 6: Job Postings</b>	This section has a single check box that controls access to the Job Postings grid in the job opening.

## Setting Up Flexible Recruiting Processes

To set up job creation processes, use the Recruiting Process (HRS\_RP\_DEFN) component.

### Pages Used to Set Up Recruiting Processes

<i>Page Name</i>	<i>Definition Name</i>	<i>Usage</i>
<u>Recruiting Process Page</u>	HRS_RP_DEFN	Specify the dispositions for which you will configure allowable transitions and actions
<u>Dispositions and Roles Page</u>	HRS_RP_SRCDSPN_CFG	Configure context-sensitive disposition assignments that can be made by users with different roles.
<u>Actions and Roles Page</u>	HRS_RP_ACTIONS_CFG	Configure context-sensitive actions that can be performed by users with different roles.

## Understanding Flexible Recruiting Processes

Flexible recruiting processes enable you to establish different recruiting processes for applicants in specific dispositions. Based on the rules you set up, users who are presented with a limited list of appropriate choices when they:

- Use the Edit Disposition action to manually change an applicant's disposition.
- Perform recruiting actions.

Rules are role-specific. User with a role that is not specifically configured are always presented with unfiltered lists of options.

### Disposition Transitions

A flexible recruiting process controls manual disposition changes. Manual disposition changes are disposition changes that are performed using the Edit Disposition action.

When you set up a recruiting process, you define valid disposition transitions for each recruiting role type. For example, you might allow recruiters, but not hiring managers, to manually move an applicant from

the *Applied* disposition to the *Reject* disposition. In this example, *Applied* is called the *source* disposition, and *Reject* is called the *target* disposition.

You can also configure different transition rules for different types of applicants (internal, external, and non-employees).

---

**Note:** When you set up valid transitions for a particular role, you cannot have gaps in the process. For example, if hiring managers cannot manually transition applicants into the Interview disposition, then they also cannot manually transition applicants out of the Interview disposition. Even if you inadvertently configure the process to allow hiring managers to manually transition applicants out of the Interview disposition, the Edit Disposition action will not allow it.

---

If an applicant's current disposition does not have any valid transitions for a particular recruiting role type, then users with that role type do not have access to the Edit Disposition action for that applicant. For example, if hiring managers have no valid target dispositions for the *Offer* source disposition, then hiring managers will not see the Edit Disposition action for applicants in the *Offer* disposition.

This example illustrates a recruiting process that limits hiring managers to two target dispositions when the source disposition is *Applied*. First, you see the configuration page for defining valid targets. Next, you see the read-only grid that summarizes available transitions, first for all users and then filtered to show only hiring manager transitions. Finally, you see the Edit Disposition dialog box limiting the hiring manager to the two specified targets.

Configure the transitions for applicants in *Applied* status:

### Dispositions and Roles

Source Disposition 010 Applied Configure Available Actions

Available Transitions ?

Dispositions	External	Employee	Non-Employee	Recruiter	Hiring Manager	
020 Reviewed	<input checked="" type="checkbox"/>	<input checked="" type="checkbox"/>	<input checked="" type="checkbox"/>	<input checked="" type="checkbox"/>	<input checked="" type="checkbox"/>	+ -
050 Route	<input checked="" type="checkbox"/>	<input checked="" type="checkbox"/>	<input checked="" type="checkbox"/>	<input checked="" type="checkbox"/>	<input checked="" type="checkbox"/>	+ -
060 Interview	<input checked="" type="checkbox"/>	<input checked="" type="checkbox"/>	<input checked="" type="checkbox"/>	<input checked="" type="checkbox"/>	<input type="checkbox"/>	+ -
070 Offer	<input checked="" type="checkbox"/>	<input checked="" type="checkbox"/>	<input checked="" type="checkbox"/>	<input checked="" type="checkbox"/>	<input type="checkbox"/>	+ -
110 Reject	<input checked="" type="checkbox"/>	<input checked="" type="checkbox"/>	<input checked="" type="checkbox"/>	<input checked="" type="checkbox"/>	<input type="checkbox"/>	+ -

↓

Review transitions for *Applied* status, using the Filter By field to view transitions for a single role.

Flexible Recruiting Process Configuration ?

Filter by **\*ALL\***

Disposition Setup ?	Predecessor Dispositions	Source Disposition	Available Transitions	
	020 Reviewed	010 Applied (Default)	020 Reviewed 050 Route 060 Interview 070 Offer 110 Reject	Modify Transitions

Flexible Recruiting Process Configuration ?

Filter by **Hiring Manager**

Disposition Setup ?	Predecessor Dispositions	Source Disposition	Available Transitions	
	020 Reviewed	010 Applied (Default)	020 Reviewed 050 Route	Modify Transitions

↓

Hiring Manager uses the Edit Disposition Action for an applicant in *Applied* status:

### Edit Disposition

Current Disposition 010 Applied

\*New Disposition

Status Reason

Date

020 Reviewed  
050 Route

Save Cancel

The recruiting process does not prevent the system from updating dispositions as part of other processing. In particular, if a user has access to an action that updates a disposition, the user can perform that action even if the resulting disposition change would not have been permitted by the Edit Disposition action. For example, if your recruiting process for the *Applied* disposition gives hiring managers access to the Reject action, then hiring managers can still reject applicants even if *Reject* is not a permitted transition.

The recruiting process also does not affect any disposition changes caused by automated status change effects that are configured on the [Effects of Status Change Page](#).

## Recruiting Actions

A flexible recruiting process controls action availability based on an applicant's disposition. For example, if an applicant is in an *Offer* disposition, a flexible recruiting process could limit recruiters to the Accept Offer and Reject Offer actions, while not allowing hiring managers to perform any actions.

The recruiting process applies to only a subset of actions, including:

- These recruiting actions (actions that have to do with the relationship between an applicant and a job opening):
  - Mark Reviewed
  - Route Applicant
  - Manage Interviews
  - Create Interview Evaluation
  - Prepare Job Offer
  - Accept Offer
  - Reject Offer
  - Prepare for Hire
  - Withdraw from Hire
  - Withdraw Application
  - Reject Applicants
  
- These applicant actions (actions that are not related to a specific job application):
  - Pre-Employment Check
  - Manage Applicant Contracts

---

**Note:** Some actions are available only for applicants in specific dispositions regardless of the flexible processing definition. For example, the Prepare for Hire action is available only for applicants in *Offer Accepted* status even if a flexible recruiting process defines this actions as available for applicants in other dispositions.

---

This example illustrates the use of a flexible recruiting process to limit the actions that can be performed on applicants in the *Applied* disposition. The example shows the configuration page for defining valid actions, then shows the results of the configuration for both recruiters and hiring managers.

In this example, the Application icon and the Edit Application Details menu command are shown to the recruiter but not to the hiring manager. These page elements are not controlled by the flexible recruiting process. Rather, they are shown only to users who have standard PeopleTools security access to the pages that are accessed through these commands.

**Configure the actions that can be performed for applicants in *Applied* status:**

**Actions and Roles**

Source Disposition 010 Applied

**Configure Available Actions** (?)

Actions	Recruiter	Hiring Manager
Select or Deselect Actions	<input type="checkbox"/>	<input type="checkbox"/>
Route Applicant	<input checked="" type="checkbox"/>	<input checked="" type="checkbox"/>
Manage Interviews	<input checked="" type="checkbox"/>	<input checked="" type="checkbox"/>
Create Interview Evaluation	<input type="checkbox"/>	<input type="checkbox"/>
Prepare Job Offer	<input checked="" type="checkbox"/>	<input type="checkbox"/>
Pre-Employment Check	<input type="checkbox"/>	<input type="checkbox"/>
Prepare For Hire	<input type="checkbox"/>	<input type="checkbox"/>
Manage Applicant Contracts	<input type="checkbox"/>	<input type="checkbox"/>
Reject Applicant	<input checked="" type="checkbox"/>	<input type="checkbox"/>
Accept Offer	<input type="checkbox"/>	<input type="checkbox"/>
Withdraw From Hire	<input type="checkbox"/>	<input type="checkbox"/>
Withdraw Application	<input type="checkbox"/>	<input type="checkbox"/>
Mark Reviewed	<input checked="" type="checkbox"/>	<input checked="" type="checkbox"/>
Reject Offer	<input type="checkbox"/>	<input type="checkbox"/>

↓

**Actions allowed for recruiters**

Disposition	Application	Mark Reviewed	Route	Interview	Reject	Other Actions
Applied						<ul style="list-style-type: none"> <li>Prepare Job Offer</li> <li>Edit Application Details</li> <li>Edit Disposition</li> </ul>
Reviewed						<ul style="list-style-type: none"> <li>Recruiting Actions</li> <li>Applicant Actions</li> </ul>

[Create New](#) | [Clone](#) | [Refresh](#) | [Add Note](#) | [No Category](#)
[Top of Page](#)

↓

**Actions allowed for hiring managers**

Disposition	Mark Reviewed	Route	Interview	Reject	Other Actions
Applied					<ul style="list-style-type: none"> <li>Edit Disposition</li> <li>Recruiting Actions</li> <li>Applicant Actions</li> </ul>
Reviewed					<ul style="list-style-type: none"> <li>Recruiting Actions</li> <li>Applicant Actions</li> </ul>

[Clone](#) | [Refresh](#) | [Add Note](#) | [No Category](#)
[Top of Page](#)

Note that if an action (such as Reject) is normally performed by clicking an icon, the icon is hidden rather than disabled when the action is not allowed. If a user cannot perform the action for any of the applicants in the grid, the entire column is hidden.

## Prerequisites

Before setting up flexible recruiting processes, use the [Status Successors Page](#) to define all acceptable successors for each disposition. Only the successors defined on the Status Successors page are available as target dispositions when you define your flexible process.

## Recruiting Process Page

Use the Recruiting Process page (HRS\_RP\_DEFN) to specify applicant dispositions for which you will configure allowable actions and allowable disposition transitions.

Navigation:

**Set Up HCM > Product Related > Flexible Processes > Recruiting Process > Recruiting Process**

This example illustrates the Recruiting Process page.

### Recruiting Process

Recruiting Process ID 1000

\*Description  Short Description

Status  Status Date

Flexible Recruiting Process Configuration ?

Filter by

Disposition Setup <span style="float: right;">?</span>				
Predecessor Dispositions	Source Disposition	Available Transitions		
	010 Applied (Default)	020 Reviewed 060 Interview 110 Reject	Modify Transitions	
010 Applied	020 Reviewed	060 Interview 110 Reject	Modify Transitions	🗑
010 Applied 020 Reviewed	060 Interview	070 Offer 110 Reject	Modify Transitions	🗑
060 Interview	070 Offer	080 Ready to Hire 090 Hired 110 Reject	Modify Transitions	🗑
070 Offer	080 Ready to Hire	090 Hired 110 Reject	Modify Transitions	🗑

Priority of Recruiting Roles ?

*Priority	*Recruiting Role Type	
<input type="text" value="2"/>	<input type="text" value="Recruiter"/>	🗑
<input type="text" value="1"/>	<input type="text" value="Hiring Manager"/>	🗑



<b>Field or Control</b>	<b>Description</b>
<b>Status and Status Date</b>	Indicate whether the definition is <i>Active</i> or <i>Inactive</i> , and enter the date that the status was assigned. Only active definitions are available for selection in flexible process templates. (However, an inactive recruiting process is still used by any flexible process templates that it is already associated with.)

## Flexible Recruiting Process Configuration

<b>Field or Control</b>	<b>Description</b>
<b>Filter By</b>	<p>Use the <b>Filter By</b> drop-down list box to control the information that appears in the Disposition Setup grid, where you can see the dispositions transitions that the recruiting process allows. Because transitions rules can be different for users with different recruiting role types, filtering by role type helps you see the complete set of transitions allowed for particular types of users.</p> <p>Select a recruiting role type to view the transitions associated with that role type, or select <i>*ALL*</i> to remove the filter and see all available transitions without regard for which users can perform the transitions.</p>

## Disposition Setup

When a user manually changes an applicant's disposition, the starting disposition is the *source* disposition, and the newly assigned disposition is the *target* disposition. To define valid transitions, you list the valid targets for each possible source.

---

**Note:** Flexible recruiting processes allow users to move applicants both forward and backward in the recruiting process. This means that the Edit Disposition action lists both predecessor and target dispositions as available options. For example, if *Reviewed* is a target of *Applied*, then the Edit Disposition page for applicants who are currently in the *Reviewed* disposition includes *Applied* as a possible new disposition, along with the dispositions that are configured as targets of *Reviewed*.

---

The Disposition Setup grid displays a row for each source where you have defined valid transitions. The first row is always the disposition that is configured as the system-wide default on the [Recruiting Status Area Page](#). This disposition is assumed to be the usual starting point of your recruiting process, and you cannot delete this row.

<b>Field or Control</b>	<b>Description</b>
<b>Predecessor Dispositions</b>	<p>Displays a list of dispositions that are valid predecessors of the corresponding source disposition. That is, an applicant who is in any of the predecessor dispositions can be manually moved to the disposition shown in the Source Disposition column.</p> <p>The system derives the list of predecessor dispositions based on settings on the Dispositions and Roles page.</p> <p>If the <b>Filter By</b> field is <i>All</i>, the transition might be allowed for some but not all recruiting role types. To verify that a transition is available for a particular recruiting role type, use the <b>Filter By</b> field to show only transitions for a that role type.</p>
<b>Source Disposition</b>	<p>Displays the disposition whose configuration is shown in the row. The system creates a row for the default disposition (as delivered, this is the <i>Applied</i> disposition). To configure an additional disposition, you must first make sure the disposition appears as a valid successor to an existing disposition. Then, click the <b>Add Disposition</b> button to create a new row for the additional disposition.</p> <p>This architecture means that you need to start by configuring successors to the default disposition. After doing that, you can configure successors to those successors, and so on.</p> <hr/> <p><b>Note:</b> A disposition that is a valid successor for any role is available to use as a source disposition. However, you should not use it as a source disposition for a role where it is not a valid successor. For example, if Interview is a valid successor for recruiters but not for hiring managers, then when you use Interview as the source disposition, be sure not to assign any successor dispositions for hiring managers.</p> <hr/>
<b>Available Transitions</b>	<p>Displays the valid targets for the source disposition.</p> <p>If the <b>Filter By</b> field is <i>All</i>, the transition might be allowed for some but not all recruiting role types. To verify that a transition is available for a particular recruiting role type, use the <b>Filter By</b> field to show only transitions for a that role type.</p>
<b>Modify Transitions</b>	<p>Click to access the pages where you configure the flexible recruiting process rules for the source disposition.</p> <p>Initially, you access the Dispositions and Roles page, where you define the valid targets for the source disposition. From that page, you can navigate to the Actions and Roles page so that you can define valid actions for the source disposition.</p>

## Add Disposition

<i>Field or Control</i>	<i>Description</i>
<b>Add Disposition</b>	<p>Click this button add and configure additional source dispositions for the flexible recruiting process.</p> <p>Initially, you access the Dispositions and Roles page, where you choose the source disposition and define its valid targets. From that page, you can navigate to the Actions and Roles page so that you can define valid actions for the source disposition.</p> <hr/> <p><b>Important!</b> The Add Disposition button does not allow you to add a row unless the first target in the last row of the Disposition Setup grid has at least one successor. This restriction makes it important for you to carefully analyze the order in which you set up your transitions. For example, you might need to configure transitions for the Hold and Linked dispositions early in your setup so that you don't end up unable to configure any targets for those dispositions.</p> <hr/>

## Priority of Recruiting Roles

<i>Field or Control</i>	<i>Description</i>
<b>Priority</b>	<p>Enter a priority to control which role's settings to use when a person has more than one recruiting role type.</p> <p>Lower numbers have higher priority. For example, if you give the Recruiter role priority 1, and you give the Hiring Manager priority 2, then a user who has both roles will use the settings associated with the Recruiter role.</p>

<b>Field or Control</b>	<b>Description</b>
<b>Recruiting Role Type</b>	<p>Create a row for each recruiting role type that you will associate with recruiting process settings.</p> <p>Recruiting role types are functional groups of PeopleTools roles such as Recruiters and Hiring Managers. Use the <a href="#">Recruiting Roles Page</a> to choose which PeopleTools roles belong to each recruiting role type.</p> <p>The drop-down list box shows only recruiting role types that are associated with at least one PeopleTools role. The list does not include the Recruitment Administrator role type because administrators are never subject to flexible process restrictions.</p> <p>Users without any of the roles you specify will not be subject to flexible process restrictions. For example, if you create a row for hiring managers so that they see only a subset of job opening fields, but you do not create a row for recruiters, then recruiters who are not also hiring managers will have access to all actions and will be able to manually move applicants from any disposition to any disposition.</p>

## Dispositions and Roles Page

Use the Dispositions and Roles page (HRS\_RP\_SRCDSPN\_CFG) to configure context-sensitive disposition assignments that can be made by users with different roles.

Navigation:

On the [Recruiting Process Page](#), click the **Configure Transitions** link for a disposition that has not yet been configured, or click the **Modify transitions** link for a disposition that was previously configured.

This example illustrates the Dispositions and Roles page.

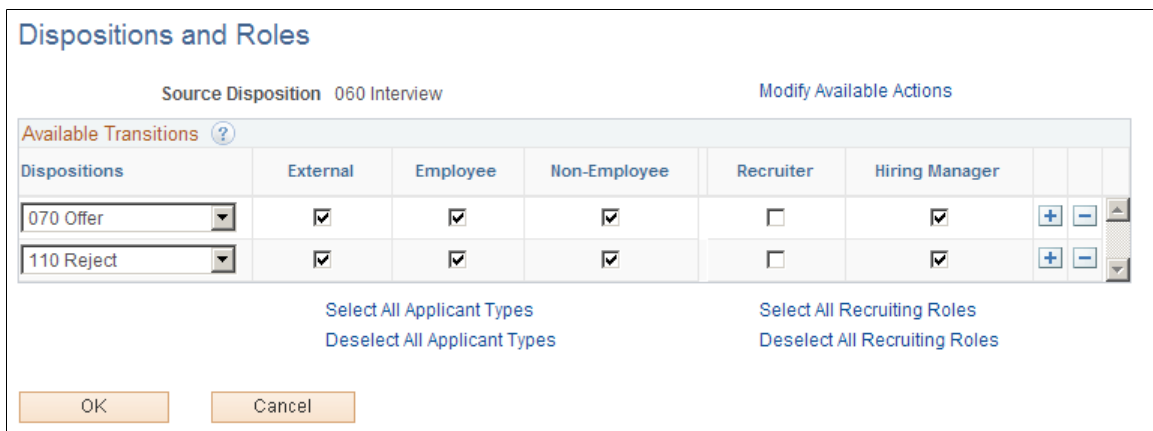

<b>Field or Control</b>	<b>Description</b>
<b>Source Disposition</b>	<p>If you access this page by clicking the <b>Modify Transitions</b> link for an existing source disposition, this field displays the disposition that you are configuring.</p> <p>If you access this page by clicking the <b>Add Disposition</b> button, select the source disposition that you want to configure. The available values are the dispositions that you have already configured as successors for another disposition. For example, if the Interview disposition has been set up as a successor for the Applied disposition, then Interview is available to use as a source disposition.</p>
<b>Modify Available Actions</b>	Click to access the Actions and Roles page, where you configure role-based access to actions for this source disposition.

## Available Transitions

<b>Field or Control</b>	<b>Description</b>
<b>Dispositions</b>	<p>Define the target dispositions for the current source disposition. The available values are:</p> <ul style="list-style-type: none"> <li>The dispositions that are defined as successors on the <a href="#">Status Successors Page</a>.</li> </ul> <p>This page is part of your general-purpose status configuration. It is not specific to flexible processing.</p> <ul style="list-style-type: none"> <li>The source disposition's predecessors within the current flexible recruiting process.</li> </ul>
<b>External, Internal, and Non-Employee</b>	<p>Select the check boxes for types of applicants who can be manually transitioned from the source to the specified target.</p> <p>If different roles can perform the transition for different applicant types, create multiple rows for the transition. For example, if both recruiters and hiring managers can assign the target disposition to external users, but only recruiters can assign the target disposition to internal users, then create one row where you select just the <b>External</b> check box and another row (with the same target) where you select just the <b>Internal</b> check box.</p>

<b>Field or Control</b>	<b>Description</b>
<Recruiting Role Type>	<p>Select the check boxes for the recruiting role types that can perform the specified transition. The system dynamically generates columns and check boxes for recruiting role types that are associated with PeopleTools roles. However, the recruiting administrator role type is not available because administrators are not subject to flexible process restrictions.</p> <p>Typically, there are columns for the <b>Recruiter</b> and <b>Hiring Manager</b> recruiting role types.</p> <hr/> <p><b>Note:</b> Do not select check boxes for a role where the current source disposition is not already a valid successor. For example, if Interview is a valid successor for recruiters but not for hiring managers, then when you use Interview as the source disposition, be sure not to assign any successor dispositions for hiring managers.</p> <hr/>
<b>Select All Applicant Types and Deselect All Applicant Types</b>	Use these links to select or deselect the <b>External, Internal, and Non-Employee</b> check boxes for every transition in the grid.
<b>Select All Recruiting Roles and Deselect All Recruiting Roles</b>	Use these links to select or deselect the recruiting role check boxes for every transition in the grid.

## Actions and Roles Page

Use the Actions and Roles page (HRS\_RP\_ACTIONS\_CFG) to configure context-sensitive actions that can be performed by users with different roles.

Navigation:

On the [Dispositions and Roles Page](#) page, click the **Modify Available Actions** link.

This example illustrates the Actions and Roles page.

Actions and Roles		
Source Disposition 010 Applied		
Configure Available Actions 		
Actions	Recruiter	Hiring Manager
Select or Deselect Actions	<input type="checkbox"/>	<input type="checkbox"/>
Route Applicant	<input checked="" type="checkbox"/>	<input checked="" type="checkbox"/>
Manage Interviews	<input checked="" type="checkbox"/>	<input checked="" type="checkbox"/>
Create Interview Evaluation	<input type="checkbox"/>	<input type="checkbox"/>
Prepare Job Offer	<input checked="" type="checkbox"/>	<input type="checkbox"/>
Pre-Employment Check	<input type="checkbox"/>	<input type="checkbox"/>
Prepare For Hire	<input type="checkbox"/>	<input type="checkbox"/>
Manage Applicant Contracts	<input type="checkbox"/>	<input type="checkbox"/>
Reject Applicant	<input checked="" type="checkbox"/>	<input type="checkbox"/>
Accept Offer	<input type="checkbox"/>	<input type="checkbox"/>
Withdraw From Hire	<input type="checkbox"/>	<input type="checkbox"/>
Withdraw Application	<input type="checkbox"/>	<input type="checkbox"/>
Mark Reviewed	<input checked="" type="checkbox"/>	<input checked="" type="checkbox"/>
Reject Offer	<input type="checkbox"/>	<input type="checkbox"/>

<i>Field or Control</i>	<i>Description</i>
<b>Source Disposition</b>	Displays the source disposition that you are configuring.

## Configure Available Actions

<b>Field or Control</b>	<b>Description</b>
<b>Actions</b>	<p>Lists the actions that you can configure using the flexible recruiting process. This is a subset of the actions that are available on the various recruiting pages.</p> <p>The first row, <i>Select or Deselect Actions</i>, is not an action. Instead, it provides a data entry shortcut. When you select or deselect this check box, the system selects or deselects all of the check boxes in the column.</p> <p>Certain actions are available only for applicants in specific dispositions regardless of the flexible processing definition. In particular:</p> <ul style="list-style-type: none"> <li>• <i>Accept Offer</i> and <i>Reject Offer</i> are available only for applicants in <i>Offer</i> status. (The applicant also must have an open offer).</li> <li>• <i>Prepare for Hire</i> is available only for applicants in <i>Offer Accepted</i> status.</li> <li>• <i>Withdraw from Hire</i> is available only for applicants in <i>Ready to Hire</i> status.</li> <li>• <i>Withdraw Application</i> is available only if the current disposition has the <i>130 Withdrawn Application</i> disposition as a successor.</li> </ul>
<b>Recruiting Role Type</b>	<p>Select the check boxes for the recruiting role types that can perform the specified action. The system dynamically generates columns and check boxes for recruiting role types that are associated with PeopleTools roles. However, the recruiting administrator role type is not available because administrators are not subject to flexible process restrictions.</p> <p>Typically, there are columns for the <b>Recruiter</b> and <b>Hiring Manager</b> recruiting role types.</p>
<b>Select All Recruiting Roles and Deselect All Recruiting Roles</b>	<p>Use these links to select or deselect the recruiting role check boxes for every action in the grid.</p>

## Setting Up Flexible Process Templates and Template Groups

To set up job flexible process templates and template groups, use the Flexible Process Template (HRS\_FLXTMPL\_DEFN) component and the Flexible Template Group (HRS\_FLXTMPLGRP\_DFN) component.



## Pages Used to Set Up Flexible Process Templates and Template Groups

<b>Page Name</b>	<b>Definition Name</b>	<b>Usage</b>
<a href="#">Flexible Process Template Page</a>	HRS_FLXTMPL_DEFN	Associate flexible processes with job opening criteria.
<a href="#">Flexible Template Group Page</a>	HRS_FLXTMPLGRP_DFN	Define a group of related flexible process templates that can be associated with a recruitment template.

## Understanding Flexible Process Templates and Template Groups

Using flexible process templates, you can associate different flexible process definitions with specific sets of job criteria. Templates enable you to assign flexible processing rules based on the job opening's Business Unit, Job Family, Job Code, Department, and Primary Recruiting Location. Collectively, these are known as the flexible processing *driver fields*.

For example, if hiring managers in department A typically enter information in a very limited subset of job opening fields, while hiring managers in department B enter information in a larger subset of job opening fields, then you can create two separate job creation processes, and use a flexible process template to choose the appropriate process definition based on the job opening's department.

Template groups enable you to associate recruitment templates with multiple flexible process templates. This architecture means that a single recruitment template can be associated with multiple flexible process templates, and the system applies the correct flexible processes based on the data in the driver fields.

When the system evaluates data in a job opening's driver fields, it first tries to find an exact match for all of the fields. If no exact match is found, the system reevaluates the templates based on the following priority for the criteria fields:

1. Business Unit
2. Primary Recruiting Location
3. Department
4. Job Code
5. Job Family

So, if there is no template that matches all five of the job opening's criteria fields, the system next looks for a template that matches the just the first four fields, then for a template that matches just the first three fields, and so forth.

If the system does not find a match, it uses the system-wide default template specified on the [Recruiting Installation - General Page](#). If there is no default template, then the system does not use any flexible processes for the job. Keep in mind that flexible processes are a usability feature, not a security feature. So when no flexible process applies, all users have access to all of the options that would otherwise be limited by flexible processing.

## Example of Template Selection

The following table shows sample criteria for four flexible process templates in a template group:

<b>Field</b>	<b>Template 1</b>	<b>Template 2</b>	<b>Template 3</b>	<b>Template 4</b>
Business Unit	<i>GBU</i>	<i>GBU</i>	<i>GBU</i>	<i>GBU</i>
Primary Recruiting Location	<i>Western Region</i>	<i>Headquarters</i>	<i>Headquarters</i>	(blank)
Department	(blank)	<i>Finance</i>	(blank)	(blank)
Job Code	(blank)	(blank)	<i>100200</i>	(blank)
Job Family	(blank)	(blank)	(blank)	(blank)

Based on this criteria:

- Job openings in the *GBU* business unit and the *Western Region* recruiting location use template 1.
- In the *GBU* business unit and the *Headquarters* location:
  - Job openings in the *Finance* department use template 2.
 

This includes job openings for job code *100200* in the *Finance* department. Although job code *100200* is associated with template 3, the department has higher priority than the job code when determining template selection.
  - Job openings for job code *100200* in any department other than *Finance* use template 3.
- Job openings in the *GBU* business unit in any location other than the *Western Region* and *Headquarters* use template 4.
- Job openings in business units other than *GBU* use the default flexible template specified in the Recruiting Installation component, if any.

## Flexible Process Template Page

Use the Flexible Process Template page (HRS\_FLXTMPL\_DEFN) to associate flexible processes with job opening criteria.

Navigation:

**Set Up HCM > Product Related > Recruiting > Templates > Flexible Process Template**

This example illustrates the Flexible Process Template page.

### Flexible Process Template

Flexible Process Template ID 1000

\*Description  Short Description

Status  Status Date

**Job Criteria**

\*Business Unit  Global Business Institute BU

Job Family  Clerical

Job Code  Clerk-Data Entry

Department

Primary Recruiting Location  California Location

**Flexible Processes**

Job Creation Process ID  Job Creation

Recruiting Process ID  Corporate Hire

<b>Field or Control</b>	<b>Description</b>
<b>Flexible Process Template ID</b>	Displays a system-assigned unique identifier for this template.
<b>Description and Short Description</b>	Enter descriptive identifiers for the template. The system displays the full description when you search for templates or when you reference a template from a template group.
<b>Status and Status Date</b>	<p>Indicate whether the definition is <i>Active</i> or <i>Inactive</i>, and enter the date that the status was assigned. Only active templates are available for selection in flexible template groups.</p> <p>If a template is already in use and then you inactivate it or set its active date to the future, the system still enforces the template's flexible processes.</p>

### Job Criteria

Use the fields in this section to define the contexts in which specific flexible processes are used. For example, if you created processes to be used for a specific business unit or department, identify the business unit and department in these fields.

**Note:** Changes to a job opening's Business Unit, Job Code, Department, or Primary Recruiting Locations can affect which flexible process template governs the job opening. However, the system does not apply the new template until the next time the Job Opening component is opened.

<b>Field or Control</b>	<b>Description</b>
<b>Business Unit</b>	Select the business unit for this template. This is a required field.

<b>Field or Control</b>	<b>Description</b>
<b>Job Family</b>	<p>Enter the job family for this template.</p> <p>If the <u>Recruiting Installation - General Page</u> does not have <i>Job Family</i> as the Template Segmenting Type, job openings are not associated with a job family. Therefore, you should leave this field blank.</p> <p>If the segmenting type is <i>Job Family</i>, remember that your recruitment templates can be associated with specific job families. If you specify a job family in a flexible process template, be the recruitment template that references the flexible process template is used for the specified job family.</p>
<b>Job Code</b>	<p>Enter the job code for this template. If the <u>Recruiting Installation – Jobs Page</u> is configured to allow multiple job codes in a job opening, the system uses only the primary job code when determining which flexible template to use.</p>
<b>Department</b>	<p>Enter the department for this template.</p>
<b>Primary Recruiting Location</b>	<p>Enter the primary recruiting location for this template. Job openings can have multiple recruiting locations, but the system uses only the primary recruiting location when determining which flexible template to use.</p>

### Flexible Processes

<b>Field or Control</b>	<b>Description</b>
<b>Job Creation Process ID</b>	<p>Select the flexible job creation process to be just for job openings that match the specified job criteria.</p>
<b>Recruiting Process ID</b>	<p>Select the flexible recruiting process to be just for job openings that match the specified job criteria.</p>

### Flexible Template Group Page

Use the Flexible Template Group page (HRS\_FLXTMPLGRP\_DFN) to define a group of related flexible process templates that can be associated with a recruitment template.

Navigation:

**Set Up HCM > Product Related > Recruiting > Templates > Flexible Template Group**

This example illustrates the Flexible Template Group page.

### Flexible Template Group

Flexible Template Group ID 1000

**Flexible Group Information**

\*Description       Short Description

Effective Date       Status

**Flexible Templates** Personalize | Find | View All | |

First 1 of 1 Last

*Flexible Process Template ID	Description	
<input type="text" value="1000"/>	Service Job Posting	+ -

<b>Field or Control</b>	<b>Description</b>
<b>Flexible Template Group ID</b>	Displays a system-assigned unique identifier for this template group.
<b>Description and Short Description</b>	Enter descriptive identifiers for the template group. The system displays the full description when you search for template groups and when you reference a template group from a recruitment template.
<b>Effective Date and Status</b>	Indicate whether the definition is <i>Active</i> or <i>Inactive</i> , and enter the date that the status was assigned. Only templates that are active as of a recruitment template’s effective date are available for selection in the recruitment template.

### Flexible Templates

<b>Field or Control</b>	<b>Description</b>
<b>Flexible Process Template ID</b>	<p>Select one or more flexible process templates to use for job openings that are associated with this flexible template group.</p> <p>Be sure to thoroughly analyze the interaction of the job criteria fields on the flexible templates that belong to the same group.</p>



# Setting Up Recruiting Templates

---

## Understanding Recruiting Templates

Recruiting Solutions uses various types of templates to control the layout and information on specific pages in PeopleSoft Talent Acquisition Manager and PeopleSoft Candidate Gateway.

### Template Types

There are five types of templates that control specific recruiting processes:

- *Resume templates* control the structure and content of the pages that applicants see when they use PeopleSoft Candidate Gateway to submit an online application.
- *Job opening templates* define the structure and content of the pages you use to create and view job openings.
- *Job posting templates* define the structure and content for job postings in a job opening.
- *Screening templates* provide default screening settings for a job opening.
- *Interview Evaluation templates* define the evaluation categories and rating scale that interviewers use when evaluating applicants.

Job openings are associated with these templates through a sixth type of template, the *recruitment template*. The recruitment template does not control a specific process. Rather, it references the other types of templates so that they, in turn, are associated with the job opening. (Recruitment templates also reference an employee referral program, which is not a template.)

The following diagram illustrates the association of templates with job openings. The job opening is associated with a recruitment template, which is in turn associated with the five types of process-specific templates.

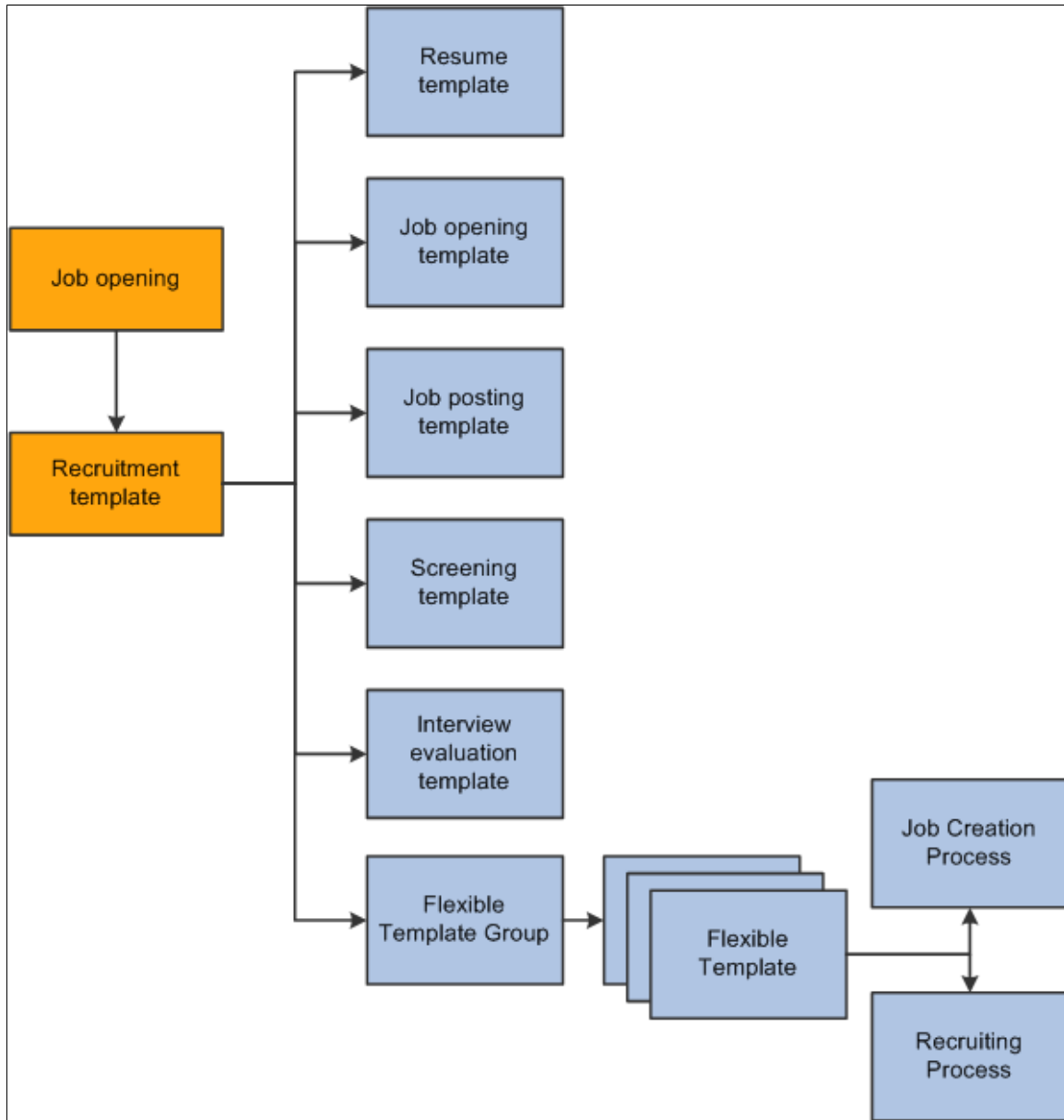

---

**Note:** When applicants use Candidate Gateway to apply, but they do not specify a job opening, there is no recruitment template available. Therefore, you must also identify a default resume template for each site.

---

### Recruitment Templates and Job Openings

When a recruiter creates a job opening, the system associated the job opening with a recruitment template based on a particular attributes of the job. You choose which attribute to use for this purpose by selecting a *template segmenting type* on the Recruiting Installation - General page.

Available segmenting types are:

- *Business Unit.*



- *Company.*
- *Department.*
- *Job Code.*
- *Job Family.*
- *Job Profile.*
- *Salary Grade.*

For example, if the segmenting type is *Department*, then you can associate different recruitment templates with different departments in your organization. You also use the Recruiting Installation - General page to identify the default recruitment template for when a job opening has a department that is not explicitly associated with a recruiting template.

The Primary Job Opening Information page (where recruiters enter basic job opening information before continuing to the main job opening pages) always includes a required field that corresponds to the segmenting type. The value that the recruiter enters enables the system to apply the appropriate recruitment template before displaying the main Job Opening page.

---

**Note:** Although the system sets a job opening's recruitment template based on the segmenting data, users with administrator privileges can change the template manually on the Job Opening page. Changing the template clears certain data.

---

## Template Modifications

Templates other than recruitment templates are not effective dated, so changes that you make to those templates carry through to previously created job openings. For this reason, the best practice is not to modify templates once they have been used. Instead, create new templates.

---

## Setting Up Resume Templates

To set up resume templates, use the Setup Resume Template (HRS\_RES\_TEMPL) component.

### Pages Used to Set Up Resume Templates

<i>Page Name</i>	<i>Definition Name</i>	<i>Usage</i>
<u>Template Definition Page</u>	HRS_RES_TMPL1	Define basic information for resume templates.
<u>Template Sections Page</u>	HRS_RES_TMPL2	Define resume template steps, including substeps and sections.
<u>(NIR) Country Specific Page</u>	HRS_RES_TMPL3	(NIR) Define whether the application process collects community background information for Northern Ireland

<b>Page Name</b>	<b>Definition Name</b>	<b>Usage</b>
<u>Pre Screening Page</u>	HRS_RES_TMPL4	Define prescreening for applicants who apply without a job opening using this resume template.
<u>Answers to Screening Questions Page</u>	HRS_RES_ANSWER_SEC	Review the answers to a prescreening question and assign points to each answer.
<u>Default Questions Page</u>	HRS_RES_TMPL5	Define default Skills and Employment questions for job openings that use this resume template.

## Understanding Resume Templates

Resume templates define and organize the information that Candidate Gateway collects from applicants during the online job application process.

### The Online Application Process

Candidate Gateway provides applicants with a guided application process. In Classic Candidate Gateway, the process is represented by a horizontal bar that displays the steps in the application process. In Fluid Candidate Gateway, the process is represented by an activity guide.

This example illustrates the Classic Candidate Gateway guided application process. Because the process is configurable, the steps shown here are only an example.

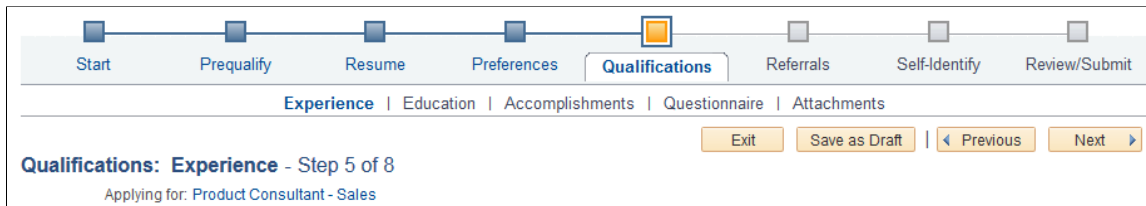

This example illustrates the Fluid Candidate Gateway activity guide. Because the process is configurable, the steps shown here are only an example.

The general flow of the online application process is the same regardless of the settings in the resume template. This flow includes:

1. Start step for notices and terms & agreements, if applicable.
 

Terms and conditions and other start step content are enabled on the “Site Setup Page” (PeopleSoft Candidate Gateway). Prequalification notices also appear on the Start step; these come from the screening level definition.
2. Prequalify step for prescreening, if applicable.
 

Prescreening for job openings is configured within the job opening. The default resume template for a site includes prescreening settings for applicants who apply without a job opening.
3. Resume step, if enabled in the resume template.
 

Use the resume template to choose whether this step includes resume options, cover letter options, or both.
4. A varying number of additional application steps (with optional substeps) that are configured in the resume template.
 

In the example above, the resume template includes three such steps: Preferences, Employment Questionnaire Qualifications, and Referrals. The Qualifications step has multiple substeps.
5. (NIR) Community Background step for Northern Ireland, if activated in the resume template.

This step is not shown in the example above.

6. Self-Identify step (not controlled by the resume template))

This step, which is for external applicants only, includes up to three substeps for voluntary self-identification: Disability, Veteran, and Diversity.

**Note:** If only one self-identification substep is relevant to an application, then that page is promoted from a substep to a main step, taking the place of the Self-Identify step.

The Diversity substep is not configurable; it always appears if the job opening's recruiting location is associated with a company location in the U.S. or, if the applicant applied without a job opening, if the applicant has a U.S. address. The Disability and Veteran substeps are configured on the Site Setup page. Disability, like Diversity, appears only for US job applications.

7. Review/Submit step.

Review and Submit step

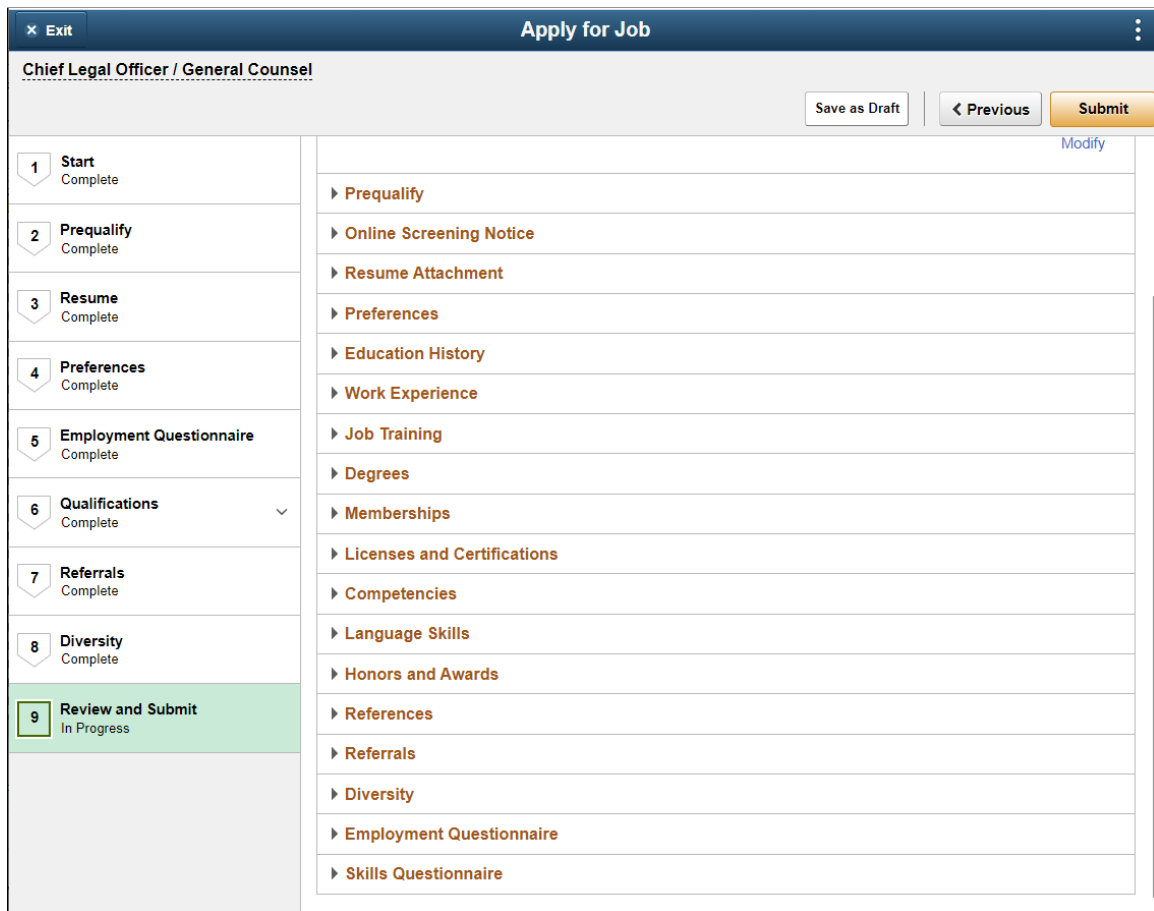

This diagram illustrates the online job application process and identifies the steps that are controlled by the resume template.

**Note:** If the applicant applies without a job opening, prescreening settings in the resume template control whether the Prequalify step appears.

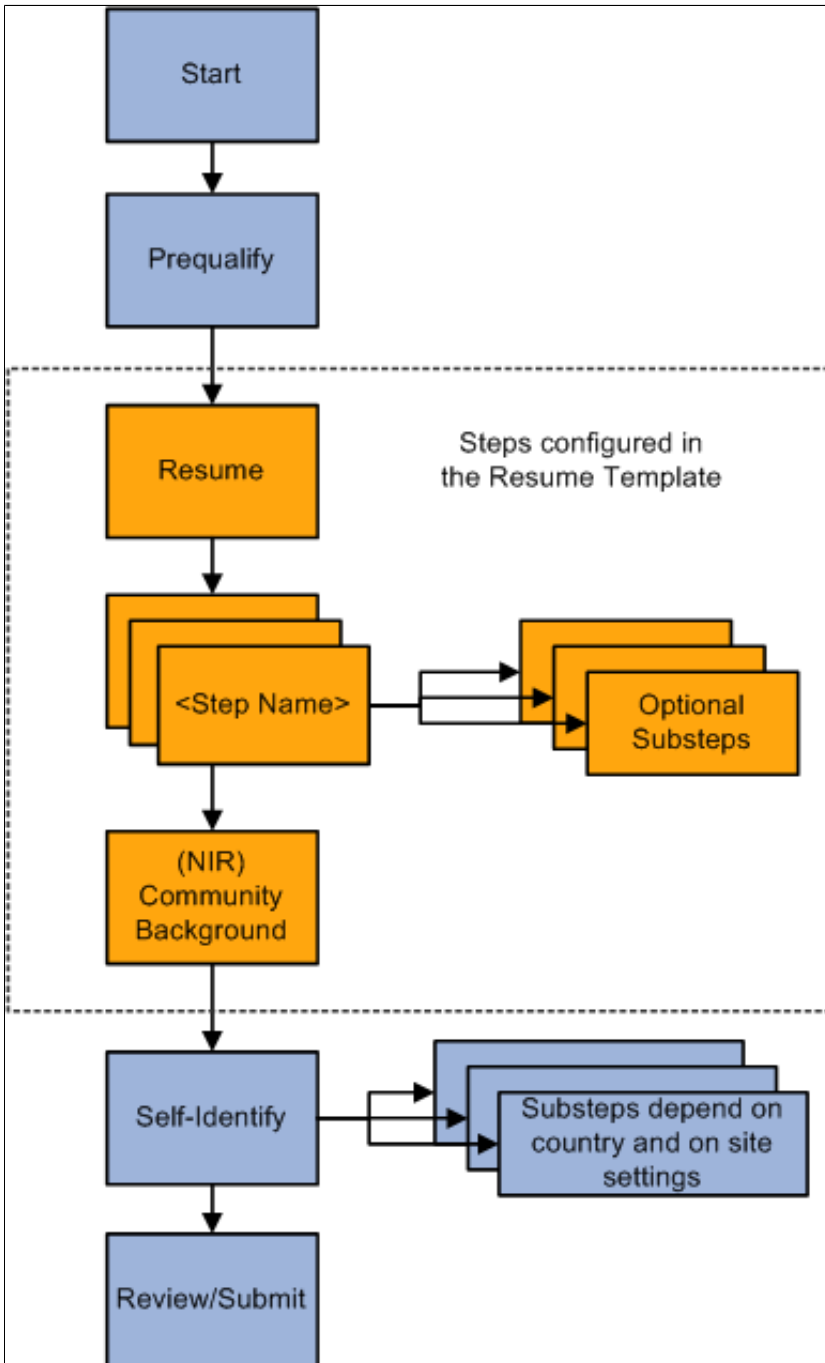

### The Resume Step

Within the resume template, you choose whether to show the Resume step in the online application process. The resume step includes two sections:

- Resume options.
- Cover letter options.

For resume options, choose whether applicants can:

- Upload a file attachment.
- Choose from a list of previously-submitted resumes.

This option is visible only to applicants who have previously submitted resumes.

- Apply without a resume.

For cover letter options, choose whether the applicants can:

- Upload a file attachment..
- Apply without a cover letter.

For both resumes and cover letters, if you don't include any of the available options, the corresponding section does not appear on the Resume step.

The settings that allow applicants to apply without a resume or a cover letter control whether the applicant can continue past the Resume step without completing the corresponding section. If you don't allow applicant to apply without providing a resume or cover letter, the word *Required* appears in the corresponding section title in Candidate Gateway. If you do allow applicants to apply without a resume or cover letter, applicants do not need to explicitly state that they are doing so, they can simply continue past the Resume step without completing the optional section.

## **Additional Steps From the Resume Template**

When you use a resume template to define a step, you:

- Choose a step name from the text catalog.
- Enter a step sequence.
- Optionally define substeps.

Substeps also require a sequence number and a name from the text catalog.

- List the sections to include on the step.

If you create substeps, each section must be associated with a substep.

There are two types of sections that are available to use in the resume template.

- Sections that correspond to the profile content types in the primary person profile type.

Oracle delivers several such sections, including competencies, language skills, degrees, and so forth. You can also configure additional content types. If you do, your custom content types are also available for selection.

---

**Note:** Within the recruiting system, use the [Content Section Configuration – <Content Type> Page](#) to configure content types for use in recruiting. In particular, use the Content Section Configuration component to configure whether applicants can add content items to a job application or whether they are limited to providing ratings for content items (such as competencies) that are already associated with the job opening.

---

See [Choosing the Primary Person Profile Type for Recruiting](#)

- Sections for these predefined types of recruiting data:

- Attachments (for non-resume attachments)

This section is not intended for resumes or cover letters, which are uploaded on the Resume step. Applicants must associate the files that they upload to this section with an attachment type that has a processing type of *References* or *Other*. Attachment types are configured on the [Attachment Type Setup Page](#).

- Education History (the applicant's highest level of education)
- (USF) Federal Preferences
- (USF) Federal Priority Placement
- Skills Questionnaire
- Employment Questionnaire
- Personal Information
- Preferences
- References (people who can provide personal or professional references)
- Referrals (how the applicant learned about the job opening)
- Training
- Work History

When an applicant applies for a job, each step shows its sections in a predefined order. This is the order in which sections appear on a step or substep:

1. Attachments section.
2. Preferences section.
3. (USF) Federal Preferences section.
4. Education History section.
5. Work Experience section.
6. Job Training section.
7. (USF) Priority Placement section.

## 8. Profile-Related sections.

All profile content type sections are grouped together. They appear in the order in which they are listed in the resume template.

## 9. References section.

## 10. Personal Information section.

## 11. Application Questionnaire section. (This can include the Skills and Employment questionnaires)

## 12. Referrals section.

These sections are all discussed in the topics “Applying for Jobs” (PeopleSoft Candidate Gateway) and “Using Fluid Candidate Gateway to Apply for Jobs” (PeopleSoft Candidate Gateway).

---

**Note:** Within a recruitment template, the resume template needs to coordinate with the job opening template. For example, if a job opening template includes a section for screening questions, the resume template must also include the Online Questionnaire section so that applicants can see and answer the questions.

---

## (NIR) Community Background Information for Northern Ireland

The Fair Employment Act 1989 requires companies in Northern Ireland with 11 or more employees to collect community background information from applicants. Applicants must enter community background information before submitting applications for job openings in Northern Ireland because an employer in Northern Ireland cannot consider job applications that do not comply with the legislation.

If you select the **Use Community Background** option on the Country Specific page in the resume template, an application that uses this template will include the Community Background step. Applicants must provide their community background information before they can continue to the next step.

Note that the system does not consider the location of the job opening when determining whether to collect community background information. To prevent the system from collecting community background information for job openings outside of Northern Ireland, be sure that resume templates where the community background option is active are used only for job openings in Northern Ireland.

When you hire an applicant, the system transfers community background information to employee data.

Recruiting administrators can manually enter community background information for applicants in the Create Applicant or Manage Applicant page in Talent Acquisition Manager. Community background information fields are on the Create Applicant page: Eligibility & Identity Tab, under the United Kingdom flag.

## Prescreening Settings

In addition to defining the steps for an online job application, a resume template can also include a prescreening definition.

If an applicant applies without selecting a job opening, the system invokes the Default Questions from the default resume template for the site.

This is a handy data entry shortcut when you have a standard set of prescreening questions for broad categories of job openings.



See [Understanding Prescreening and Online Screening](#).

---

**Note:** When an applicant applies for a job opening, the prescreening definition in the resume template is not used. Instead, the screening settings within the job opening control prescreening

---

## Resume Template Selection During the Application Process

When an applicant applies for a job opening online, the system uses the resume template that is associated with the job opening's recruitment template.

If an applicant applies without a job opening, or if the job opening is not associated with a resume template, the system uses the Default Questions tab in the resume template specified on the "Site Setup Page" (PeopleSoft Candidate Gateway).

If an applicant applies to multiple job openings that have different associated resume templates, the system merges the associated resume templates so that all possible sections are included in the new resume template and no sections are duplicated.

During the merge process, the system:

1. Determines all of the associated resume templates for all job openings to which an applicant applies for a given apply online session.
2. Determines the number of sections in each resume template.
3. Determines the resume template with the highest number of sections, and uses that resume template as the base template for the applicant's session.
4. Determines which sections from the remaining templates are not on steps in the base template.
5. Creates a new application step called *Additional Information* and adds the sections that are not in the base template to that step.

## Prerequisites

Before setting up resume templates, use the [Assign Profile Type Defaults Page](#) to choose a primary person profile type. The primary person profile type controls which profile content types are available for use in resume templates.

## Template Definition Page

Use the Template Definition page (HRS\_RES\_TMPL1) to define basic information for resume templates.

Navigation:

**Set Up HCM > Product Related > Recruiting > Templates > Resume Template > Template Definition**

This example illustrates the Template Definition page.

Template Definition
Template Sections
Country Specific
Pre Screening
>

**Template Definition**

Resume Template ID 1000
\*Effective Status Active

\*Description Default

\*Short Description Default

Status Date 06/17/2004

Save
Return to Search
Notify
Add
Update/Display

Template Definition | 
 [Template Sections](#) | 
 [Country Specific](#) | 
 [Pre Screening](#) | 
 [Default Questions](#)

<b>Field or Control</b>	<b>Description</b>
<b>Resume Template ID</b>	The system assigns the Template IDs when the template is first saved.
<b>Effective Status</b> and Status Date	Indicate whether the definition is <i>Active</i> or <i>Inactive</i> , and specify the date that the status was assigned. Only active templates are available for selection in recruitment templates. The system displays a warning if you attempt to inactivate a template that is used in a recruitment template.
<b>Description</b> and <b>Short Description</b>	Enter an identifying name for this template A descriptive name helps you when you reference the template from within a recruitment template or site definition.

## Template Sections Page

Use the Template Sections page (HRS\_RES\_TMPL2) to define resume template steps, including substeps and sections.

Navigation:

**Set Up HCM > Product Related > Recruiting > Templates > Resume Template > Template Sections**

This is the first of two examples illustrating the Template Sections page.

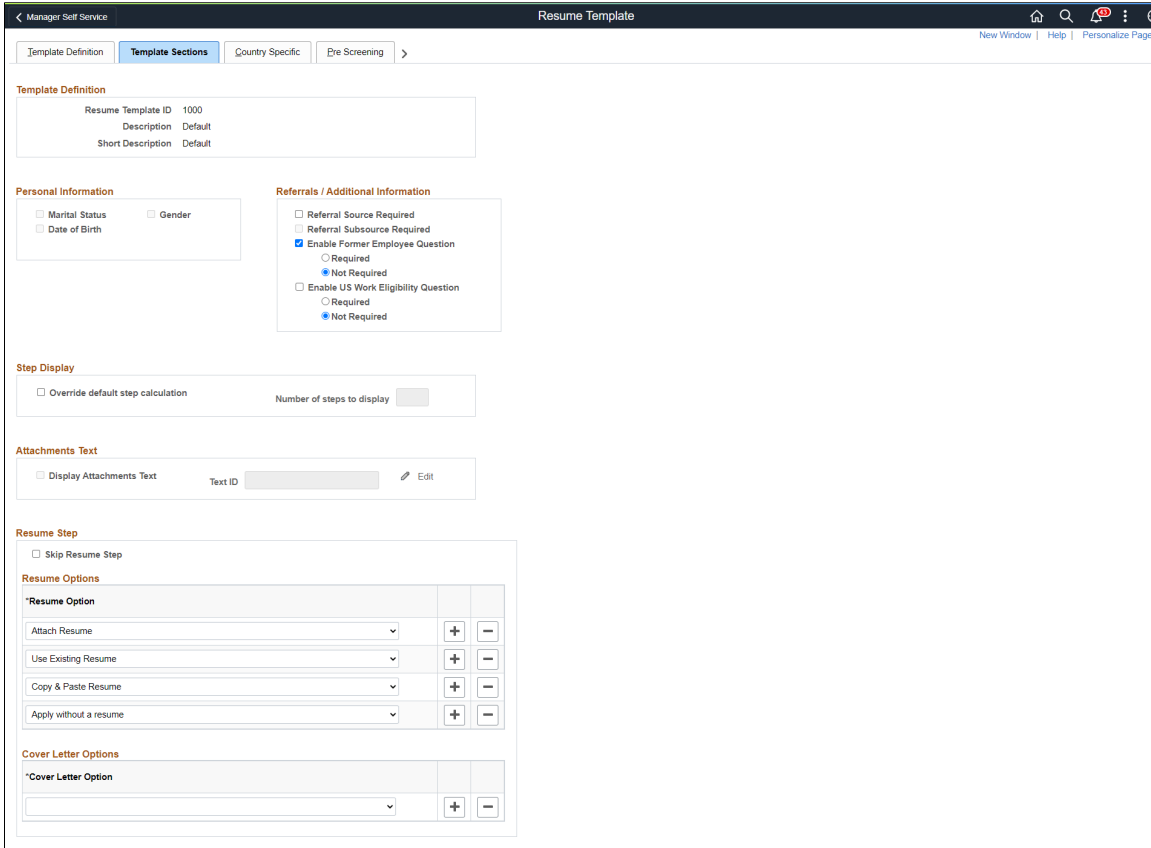

This is the second of two examples illustrating the Template Sections page.

**Steps** Q | << 1 of 4 >> | >>>

\*Step Title   Preferences + -

\*Step Sequence

**Substeps (optional)** Q | << 1-1 of 1 >> | >>>

*Sequence	Substep Name	Description		
<input type="text"/>	<input type="text" value=""/> <input type="button" value="Q"/>		+	-

**Sections** Q | << 1-1 of 1 >> | >>>

*Section Name	Substep		
Preferences <input type="button" value="v"/>	<input type="text" value=""/> <input type="button" value="v"/>	+	-

\*Step Title   Employment Questionnaire + -

\*Step Sequence

**Substeps (optional)** Q | << 1-1 of 1 >> | >>>

*Sequence	Substep Name	Description		
<input type="text"/>	<input type="text" value=""/> <input type="button" value="Q"/>		+	-

**Sections** Q | << 1-1 of 1 >> | >>>

*Section Name	Substep		
Employment Questions <input type="button" value="v"/>	<input type="text" value=""/> <input type="button" value="v"/>	+	-

\*Step Title   Qualifications + -

\*Step Sequence

**Substeps (optional)** Q | << 1-4 of 4 >> | >>>

*Sequence	Substep Name	Description		
<input type="text" value="1"/>	<input type="text" value="HGRAM_CEPROF_PT29"/> <input type="button" value="Q"/>	Experience	+	-
<input type="text" value="2"/>	<input type="text" value="HGRAM_CEPROF_PT27"/> <input type="button" value="Q"/>	Education	+	-
<input type="text" value="3"/>	<input type="text" value="HGRAM_CEPROF_PT30"/> <input type="button" value="Q"/>	Accomplishments	+	-
<input type="text" value="4"/>	<input type="text" value="HGRAM_CEPROF_PT31"/> <input type="button" value="Q"/>	Questionnaire	+	-

## Personal Information

Use this group box to select the types of personal information that you want applicants to enter when they apply for jobs online

<b>Field or Control</b>	<b>Description</b>
<b>Marital Status, Date of Birth, and Gender</b>	<p>If you include the <i>Personal Information</i> section in the template, select one or more of these check boxes to indicate which types of personal information to collect from applicants. Normally, country or regional statutes and regulations determine which options you select.</p> <hr/> <p><b>Note:</b> Do not select the Gender option in templates for jobs in the United States. When applicants apply for United States jobs, the application process includes a Diversity page where applicants can enter gender and ethnicity information.</p> <hr/> <p>These check boxes are available only if the <i>Personal Information</i> section is included in the template. If you remove the section, the system deselects the check boxes, and you will need to re-select at least one if you later add the section back to the template.</p>

**Note:** When these options are selected, the data is collected as part of the application form, not as part of the USA-specific self-identification details (gender and ethnicity) that are collected at the end of the application process for U.S. jobs. However, the field used to collect gender data is the same in both places, so if the field appears in both places during the application process, changes to the value in one step carry over to the other step.

## Referrals

If you include the *Referrals* section in the template, use these check boxes to control the fields in the Referrals section. These check boxes are available only if the *Referrals* section is included in the template. If you remove the section, the system deselects the check boxes. Adding the section back does not restore the check boxes to their previous state.

<b>Field or Control</b>	<b>Description</b>
<b>Referral Source Required</b>	<p>Select this check box to make it mandatory for applicants to specify a referral source when completing an application using this template.</p> <p>If an applicant tries to continue past the step with the Referrals section without entering the required information, the system forces the applicant to either enter the missing information, save the application as a draft, or exit the application.</p>

<b>Field or Control</b>	<b>Description</b>
<b>Referral Subsource Required</b>	<p>Select this check box to make it mandatory for the applicants to specify a referral subsource in addition to the source.</p> <p>This check box is available only when the <b>Referral Source Required</b> check box is selected.</p> <p>The system does not validate the existence of valid subsource data when you select this check box. However, even if this check box is selected, the system will allow an applicant to submit an application without a subsource if there are no subsources for the selected referral source.</p> <p>See <a href="#">Setting Up Recruitment Sources</a>.</p>
<b>Enable Former Employee Question</b>	<p>Select the check box to display the ‘Are You a former Employee?’ field in the Referrals section of the Job Application page.</p> <hr/> <p><b>Note:</b> This field applies only to External Applicants and is not displayed in the Referrals step for Internal Applicants.</p> <hr/>
<b>Required</b>	<p>Select this option to set the ‘Are You a Former Employee’ as a mandatory field. Once selected, the applicant has to answer the question ‘Are You a Former Employee?’ when completing an application using this template.</p> <p>If an applicant tries to continue past the step with the Referrals section without entering the required information, the system forces the applicant to either enter the missing information, save the application as a draft, or exit the application.</p>
<b>Not Required</b>	<p>Select this option to set the ‘Are You a Former Employee’ as a non-mandatory field when an applicant completes an application using this template.</p>
<b>Enable US Work Eligibility Question</b>	<p>Select the check box to display the ‘Eligible to Work in US’ field in the Referrals section of the Job Application page.</p>
<b>Required</b>	<p>Select this option to set the ‘Eligible to Work in US’ as a mandatory field. Once selected, the applicant has to answer the question ‘Eligible to Work in US Work’ when completing an application using this template.</p> <p>If an applicant tries to continue past the step with the Referrals section without entering the required information, the system forces the applicant to either enter the missing information, save the application as a draft, or exit the application.</p>

<b>Field or Control</b>	<b>Description</b>
<b>Not Required</b>	Select this option to set the ‘Eligible to Work in US’ as a non-mandatory field when an applicant completes an application using this template.

**Note:** Any change to ‘Are You a Former Employee’ and ‘Eligible to Work in US’ fields in Resume Template will be reflected only in the new Job Openings created using the updated Resume Template and not the existing/old job openings.

## Step Display

<b>Field or Control</b>	<b>Description</b>
<b>Override Default Step Calculation</b>	<p>During the online application process, the system positions the steps along the horizontal bar using paging algorithms that are based on the length of the step labels. Depending on the number of steps and the length of their labels, the horizontal bar might not be able to display all of the steps at once. In this case, the horizontal bar displays paging controls that enable applicants to scroll to the overflow steps .</p> <p>Select the <b>Override Default Step Calculation</b> check box to make the <b>Number of Steps to Display</b> field editable so that you can choose a fixed number of steps to display rather than using the system’s paging algorithms.</p> <p>This setting affects the main application steps only—it does not impact the display of substeps. Also, the system ignores the override if multiple resume templates are merged when an applicant applies for multiple jobs at once.</p>
<b>Number of Steps to Display</b>	Enter the number of steps that the horizontal bar should display.

**Important!** Oracle recommends that you do not use the override option. If you do use it, be sure to test your settings thoroughly to ensure that your override does not cause overlapping step labels, broken connector lines, or other display issues.

## Attachments

The fields in this group box are disabled if the template does not include the Attachments section. If you remove the Attachments section from the template, these fields are cleared.

<b>Field or Control</b>	<b>Description</b>
<b>Display Attachments Text</b>	Select this check box if you want the Attachments section in the online job application to include instructional text. Note that this setting is for the general-purpose Attachments section. It is not related to resume or cover letter attachments that applicants upload on the Resume step.
<b>Text ID</b>	<p>If you selected the Display Attachments Text check box, specify the text catalog entry that contains the instructional text to be displayed.</p> <p>Keep in mind that the same text catalog entry is used for all job applications that use this resume template. If your attachment requirements vary for different jobs, the best practice is to include the attachment requirements in the job description and use the instructional text to direct the applicant to the job description for these detailed requirements. Oracle delivers text catalog entry HRAM_ATTACH_INSTR for this purpose.</p>
<b>Edit</b>	If you entered a text ID, click the Edit link to view or edit the specified text catalog entry on the Maintain Text Catalog page.

## Resume Step

<b>Field or Control</b>	<b>Description</b>
<b>Skip Resume Step</b>	<p>Select this check box to prevent the Resume step from appearing in the guided application process. Skipping the resume step means that the guided application process will not include either the Resume section or the cover letter section.</p> <p>If you do not select this check box, be sure to configure resume options, cover letter options, or both. Otherwise applicants will see a blank resume step.</p> <hr/> <p><b>Note:</b> This setting does not apply to the Refer a Friend process in Classic Candidate Gateway. It does, however, apply to the Refer a Friend process in Fluid Candidate Gateway.</p> <hr/>



<b>Field or Control</b>	<b>Description</b>
<b>Resume Options</b>	<p>List the resume options that you want to offer to applicants.</p> <p>The options are:</p> <ul style="list-style-type: none"> <li>• <i>Attach Resume</i>: allow applicants to upload file attachments.</li> <li>• <i>Use Existing Resume</i>: allow applicants who have previously submitted resumes to choose from a list of already-submitted resumes.</li> <li>• <i>Copy &amp; Paste Resume</i>: allow applicants to enter resume text in a rich text field.</li> </ul> <p>This option applies to classic Candidate Gateway, but Fluid Candidate Gateway does not allow applicants to copy and paste resume text regardless of the resume template settings.</p> <ul style="list-style-type: none"> <li>• <i>Apply without a resume</i>: allow applicants to continue past the Resume step without supplying a resume.</li> </ul> <p>The options that you choose here are used for applicants' own applications and for applications that are created using the Refer a Friend process. However, the <i>Use Existing Resume</i> option is not valid during the Refer a Friend process.</p> <p>If this grid is empty, the Resume section does not appear on the Resume Step in the guided application process.</p> <p>If this grid does not include the <i>Attach Resume</i> option, the Resume step does not appear during the Fluid Candidate Gateway process for referring a friend. This is because <i>Attach Resume</i> is the only valid option for referrals in Fluid Candidate Gateway.</p> <p>In Classic Candidate Gateway, the Resume step always appears during the Refer a Friend process. Therefore, if you use Classic Candidate Gateway, you should always include a resume option. If you don't want applicants to see the resume step in the guided application process, select the <b>Skip Resume Step</b> check box after you enter the resume options to use for the Refer a Friend process.</p>

<b>Field or Control</b>	<b>Description</b>
<b>Cover Letter Options</b>	<p>List the cover letter options, if any, that you want to offer to applicants.</p> <ul style="list-style-type: none"> <li>• <i>Attach Cover Letter</i>: allow applicants to upload a cover letter file.</li> <li>• <i>Apply without a cover letter</i> : allow applicants to continue past the Resume step without uploading a cover letter.</li> </ul> <p>If you leave this grid empty, the cover letter section does not appear on the Resume Step in the guided application process.</p> <p>The Refer a Friend process does not include a cover letter section, so the options you choose here are only relevant to applicants' own applications.</p>

## Steps

Use this scroll area to define steps and their sequence. Use the grids within this scroll area to define the substeps and sections that make up the step.

<b>Field or Control</b>	<b>Description</b>
<b>Step Title</b>	<p>Select a text catalog entry to use as the title of the step. Only text IDs with HRAM (RS Applicant Manager) as the object owner identifier are available for selection.</p> <hr/> <p><b>Note:</b> The text catalog entered for <b>Step Title</b> and <b>Sections – Substep</b> should have different usage values. For example, the usage of text catalog for Step title and Section – Substep can be Page Title and Page Instructions. To know more on text catalogs, see Text Catalogs“Common Elements Used When Working With the Text Catalog” (Application Fundamentals).</p> <hr/>
<b>Step Sequence</b>	<p>Enter a sequence number to control the order that the steps appear in the Candidate Gateway guided application process.</p>

## Substeps (Optional)

Optionally define substeps to be rendered under the main step. Substeps, like steps, require both a sequence number and a name that comes from the text catalog.

<b><i>Field or Control</i></b>	<b><i>Description</i></b>
<b>Sequence</b>	Enter a sequence number to control the order that the substeps appear on the step.
<b>Substep Name</b>	Select a text catalog entry to use as the title of the substep. Only text IDs with HRAM (RS Applicant Manager) as the object owner identifier are available for selection.
<b>Description</b>	Displays the default text for the selected text catalog entry.

## Sections

<b><i>Field or Control</i></b>	<b><i>Description</i></b>
<b>Section Name</b>	<p>Select the sections to be included on this step. Sections cannot be added to a resume template more than once, even on different steps or substeps.</p> <p>PeopleSoft delivers several predefined sections in addition to the profile-related sections that are based on the primary person profile type.</p> <p>Sections on a step or substep appear in a predefined order, regardless of the order they are listed in the resume template. All profile-related sections are grouped together, but within that grouping, they appear in the order they are listed in the resume template.</p> <p>For information about sections and about the predefined order for sections on a step, see <a href="#">Understanding Resume Templates</a>.</p>

<b>Field or Control</b>	<b>Description</b>
<b>Required</b>	<p>Select this check box if you require applicants to provide at least one row of data for a section. This check box is visible only for sections that correspond to grids, including Attachments, Work History, Training, References, and all profile-related sections.</p> <p>Selecting the Required check box for the Attachments section forces applicants to upload at least one attachment. If you select this check box, be sure to use the Attachments Text fields on this page to set up informational text to help applicants understand what documents to upload.</p> <p>Do not make the Attachments section required unless the <u>Attachment Type Setup Page</u> is configured to allow job applications to include at least one attachment with a processing type of <i>References</i> or <i>Other</i></p> <p>For profile-related sections, consider whether applicant data will be transferred to the HR system during hire processing and whether the content type is marked as required for employees on the “Profile Types - Content Page” (PeopleSoft Human Resources Manage Profiles). If a content type that is transferred during the hire process is required for employees but not for applicants, you can encounter hire processing errors for applicants who do not have at least one row of data for the required content type. Making the content type required for applicants can help you avoid this problem. If you choose not to make the content type required in the resume template, a recruiter can manually enter a row in Talent Acquisition Manager before hiring an applicant.</p> <hr/> <p><b>Note:</b> The system ignores the <b>Required</b> setting for any profile content items where the <b>Applicant May Add Items</b> check box on the <u>Content Section Configuration – &lt;Content Type&gt; Page</u> is deselected. This configuration prevents applicants from adding rows to the grid, so it is not possible to require the applicant to provide data.</p> <hr/>
<b>Substep</b>	<p>If a step has substeps, then associate every section with a substep.</p> <hr/> <p><b>Note:</b> The text catalog entered for <b>Step Title</b> and <b>Substep</b> should have different usage values. For example, the usage of text catalog for Step title and Substep can be Page Title and Page Instructions. To know more on text catalogs, see Text Catalogs“Common Elements Used When Working With the Text Catalog” (Application Fundamentals).</p> <hr/>

## (NIR) Country Specific Page

Use the Country Specific page (HRS\_RES\_TMPL3) to define whether the application process collects community background information for Northern Ireland

Navigation:

**Set Up HCM > Product Related > Recruiting > Templates > Resume Template > Country Specific**

This example illustrates the Country Specific page.

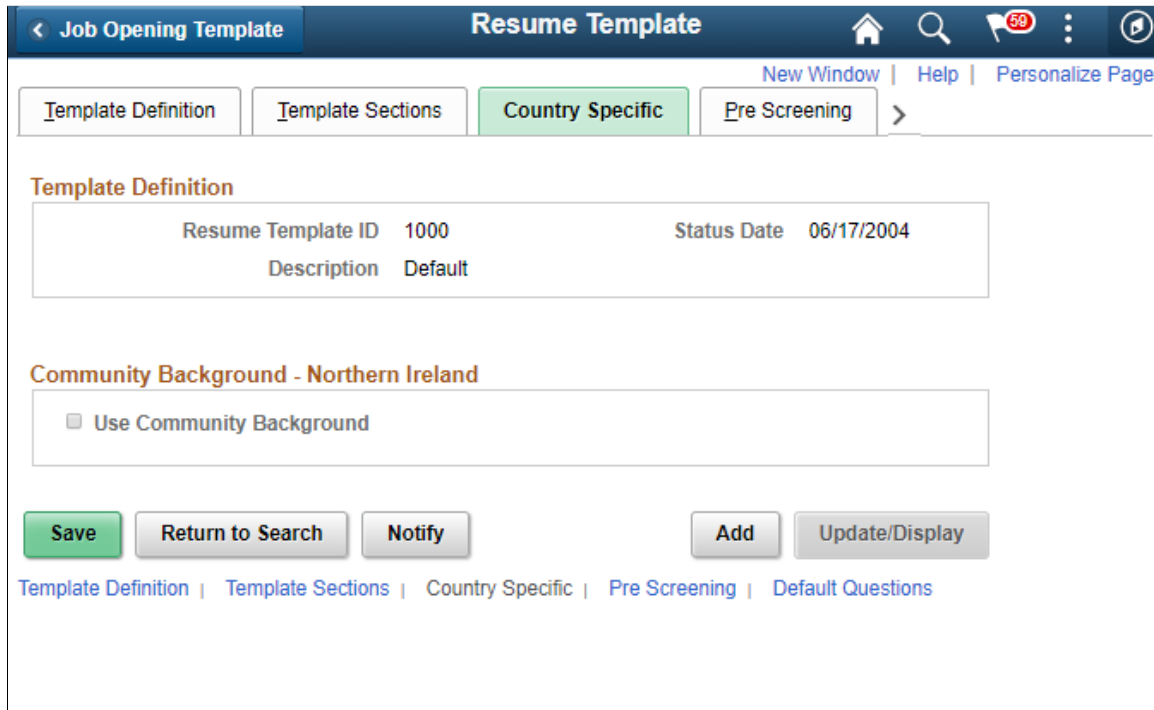

<i>Field or Control</i>	<i>Description</i>
<b>Use Community Background</b>	Select this check box to make the Community Background step appear in the guided application process. The Community Background step appears after the last of the steps that you define on the Template Sections page.

## Pre Screening Page

Use the Pre Screening page (HRS\_RES\_TMPL4) to define prescreening for applicants who apply without a job opening using this resume template.

Navigation:

**Set Up HCM > Product Related > Recruiting > Templates > Resume Template > Pre Screening**

This example illustrates the Pre Screening page.

**Template Definition**

Resume Template ID 1000 Status Date 06/17/2004  
 Description Default

**Screening Definition**

Pass Message Text ID HRAM\_CEONLPASS\_01  Pass Email  
 Fail Message Text ID HRAM\_FLONLFAIL\_01  Fail Email  
 Explain Text ID HRAM\_FLONLEMSG\_02

**Status Definition**

Pass Status 010 Applied  
 Pass Reason  
 Fail Status 112 Failed Prescreening  
 Fail Reason

**Scoring Definition**

**Percent Needed to Pass**

Percent Needed to Pass 80  Use Raw Points  
 Maximum Points to Assign  
 Points Assigned for Pass Points Assigned for Fail

**Screening Questions**

*Question	View Answers	Question Order	Use in Screening	Required to Pass	Points
21 Yrs	<a href="#">View Answers</a>		<input checked="" type="checkbox"/>	<input type="checkbox"/>	10

+ Add Screening Questions Maximum Total Points 10

Save Return to Search Notify Add Update/Display

Template Definition | Template Sections | Country Specific | Pre Screening | Default Questions

## Understanding Resume Template Prescreening Configuration

Prescreening for specific job openings is defined within the job opening. However, if an applicant applies without selecting a job opening, the system uses the questions defined in the Pre Screening tab from the default resume template of the site. The prescreening questions in this situation must be general questions (employment questions), not job-specific questions, intended for all applicants who use the site. For example, for a country-specific site, you might ask applicants if they can legally work in that country.

**Important!** When an applicant applies for a job opening, prescreening settings in the job opening (and not the prescreening settings on the resume template) determine whether prescreening occurs.

## Screening Definition Messages

If you add any prescreening questions to the resume template, the three text ID fields in this section are required.

<b>Field or Control</b>	<b>Description</b>
<b>Pass Message Text ID</b> and Fail Message Text ID	<p>Select the IDs for the messages that Candidate Gateway presents to applicants who pass and who fail this screening level.</p> <p>To create your own message, you can modify the delivered text catalog entries or create your own. If you create your own, use the following conventions to make the text catalog entries available for selection:</p> <ul style="list-style-type: none"> <li>• The object owner ID must be HRAM</li> <li>• The text ID for passing messages must be HRAM_%_PASS% (for example, HRAM_CUST1_PASS_PSCR01)</li> <li>• The text ID for fail messages must be HRAM_%_FAIL% (for example, HRAM_CUST1_FAIL_PSCR01)</li> </ul>
<b>Explain Text ID</b>	<p>Select a message for the system to display in the Prescreening Notices section of the application Start step. This message should explain what the applicant is being asked to do.</p> <p>To create your own message, you can modify the delivered text catalog entries or create your own. If you create your own, use the following conventions to make the text catalog entries available for selection:</p> <ul style="list-style-type: none"> <li>• The object owner ID must be HRAM</li> <li>• The text ID for explain messages must be HRAM_%_EMSG% (for example, HRAM_CUST1_EMSG_PSCR01)</li> </ul>
<b>Pass Email Flag</b> and Fail Email Flag	<p>Select these check boxes to make the system send the pass and fail messages to applicants by email (in addition to showing the message in Candidate Gateway). The system sends the message to the applicant's primary email address.</p>

## Status Definition

If you add any prescreening questions to the resume template, both a pass status and a fail status are required.

<b>Field or Control</b>	<b>Description</b>
<b>Pass Status and Pass Reason</b>	Select the disposition (and, if desired, an associated reason) to assign to applicants who pass this prescreening process. The selected disposition is not applied until the application is submitted, at which point this disposition overrides the default disposition that would otherwise be assigned to new applications. Typically, the pass status is <i>Applied</i> .
<b>Fail Status and Fail Reason</b>	Select the default disposition (and, if desired, an associated reason) to assign to applicants who fail this prescreening process. Typically, the fail status is <i>Failed Prescreening</i> .

### Scoring Definition and Percent Needed to Pass

Use this group box defines the rules for determining whether the applicant passes or fails prescreening.

<b>Field or Control</b>	<b>Description</b>
<b>Percent Needed to Pass</b>	Enter the minimum percentage amount of the total possible points that an applicant needs in order to pass the screening level. If the applicant must correctly answer all prescreening questions, enter 100%.
<b>Use Raw Points, Maximum Points to Assign, Points Assigned for Pass, and Points Assigned for Fail</b>	Use these fields to assign an applicant points for the screening level. These fields are the same as those on the <a href="#">Screening Definition Page</a> .

### Screening Questions

<b>Field or Control</b>	<b>Description</b>
<b>Question</b>	Select the questions to include in the prescreening questionnaire. (Prescreening questions must not be open-ended because the system cannot evaluate answers to open-ended questions.)
<b>View Answers</b>	Click to access the <a href="#">Answers to Screening Questions Page</a> , where you can review the possible answers to the question, see which answers are correct, and update the correct answer / Where Clause and point values for the answers.



<b>Field or Control</b>	<b>Description</b>
<b>Question Order</b>	<p>Enter sequence numbers for each question to establish the order in which they appear in the questionnaire. Because this field accepts only integers, consider using non-consecutive numbers to make it easier to insert additional questions between existing questions.</p> <hr/> <p><b>Note:</b> If the <b>Randomize Screening Questions</b> field on the <u>Recruiting Installation – Jobs Page</u> is set to <i>Yes</i>, then the system disregards the question order and presents questions to applicants in random order.</p> <hr/>
<b>Use in Screening</b>	<p>Select to include the question in the prescreening questionnaire for candidates who apply without a job. This page lists only the questions that you use for prescreening, so you must select this check box for all of the questions in the grid.</p>
<b>Required to Pass</b>	<p>Select to indicate that a correct answer to the question is required in order for the applicant to pass the screening process.</p> <p>An applicant who does not provide the correct answer for a required to pass question fails the screening level regardless of whether the applicant has an otherwise passing score.</p> <hr/> <p><b>Note:</b> This setting does not force applicants to supply an answer. To force applicants to answer all questions, select the <b>Require Answers to Questions</b> check box on the “Site Setup Page” (PeopleSoft Candidate Gateway). or mark the questions as required at job opening level.</p> <hr/>
<b>Points</b>	<p>Displays the point value of the correct answer or, if the question has more than one correct answer, the sum of the point values for all correct answers.</p> <p>To ensure correct processing, make sure that each question has a point value. Use the View Answers link if you need to assign or update point values.</p>
<b>Maximum Total Points</b>	<p>Displays the sum of the point values for all questions in the <b>Screening Questions</b> grid.</p>
<b>Add Screening Questions</b>	<p>Click to add another row to the <b>Screening Questions</b> grid.</p>

## Answers to Screening Questions Page

Use the Answers to Screening Questions page (HRS\_RES\_ANSWER\_SEC) to review answers to a prescreening question, and assign points to each answer.

Navigation:

Click the **View Answers** link on the Pre Screening page.

This example illustrates the Answers to Screening Questions page.

**Answers to Screening Questions**

Question ID: [Blank] Question Type: Single Choice

Are you 21 years of age or older?

**Answers**

Answer	Correct Answer	Points
Yes	<input checked="" type="checkbox"/>	10
No	<input type="checkbox"/>	

OK Cancel

<b>Field or Control</b>	<b>Description</b>
<b>Answer and Correct Answer</b>	The Answers grid lists all possible answers for the question. The Correct Answer check box is selected to indicate the correct answer or answers. Review and update the correct answer if required.
<b>Points</b>	Review and optionally override the point value for each possible answer to the question. Default point values come from the question definition. You can assign points for both correct and incorrect answers.

## Default Questions Page

Use the Default Questions page (HRS\_RES\_TMPL5) to define default skills and employment questions for job openings that use this resume template.

Navigation:

**Set Up HCM > Product Related > Recruiting > Templates > Resume Template > Default Questions**

Default Questions page.

← Default Questions
Resume Template
🏠 🔍 📌 47 ⋮

[New Window](#) | [Help](#) | [Personalize Page](#)

←

Template Sections

Country Specific

Pre Screening

Default Questions

Use this page to add default employment or skills questions for job openings that use this resume template.

Use Employment Questions when Applying Without a Job

Use Skills Questions when Applying Without a Job

**Default Employment Questions** ?

Question	Question Order	Action	Required	
Overtime <input style="width: 80%;" type="text"/>	<input style="width: 40%;" type="text" value="1"/>	<a href="#">View Answers</a>	<input checked="" type="checkbox"/>	
Driver's license? <input style="width: 80%;" type="text"/>	<input style="width: 40%;" type="text" value="2"/>	<a href="#">View Answers</a>	<input checked="" type="checkbox"/>	

Add Employment Question

Load from Question Sets

**Default Skills Questions** ?

Question	Question Order	Action	Required	
Computer Language <input style="width: 80%;" type="text"/>	<input style="width: 40%;" type="text" value="1"/>	<a href="#">View Answers</a>	<input checked="" type="checkbox"/>	
Workload Management <input style="width: 80%;" type="text"/>	<input style="width: 40%;" type="text" value="2"/>	<a href="#">View Answers</a>	<input checked="" type="checkbox"/>	

Add Skills Question

Load from Question Sets

Save

Return to Search

Notify

Add

Update/Display

<i>Field or Control</i>	<i>Description</i>
<b>Use Employment Questions when Applying Without a Job</b>	Select this option if you want to display the employment questions to candidates who apply without a job.
<b>Use Skills Questions when Applying Without a Job</b>	Select this option if you want to display the skills questions to candidates who apply without a job.
<b>Question</b>	Choose the question from the list of saved questions.
<b>Question Order</b>	Choose the order in which the questions should be displayed.

<b>Field or Control</b>	<b>Description</b>
<b>View Answers</b>	Use the View Answers link to view the question and answer and the points assigned to it. You can edit the correct answer and points if the question is not already in use in any of the job openings.
<b>Required</b>	Choose this option to make the question mandatory.
<b>Add Skills Question or Add Employment Question</b>	Use this button to add a new row for the skills or employment questions section. You cannot choose the same question for both Skills Question and Employment Question
<b>Load from Question Sets</b>	Use this button to load questions from a question set. Open ended questions will not be loaded.

## Setting Up Job Opening Templates

To set up job opening templates, use the Job Opening Template (HRS\_JO\_TMPL) component.

### Pages Used to Set Up Job Opening Templates

<b>Page Name</b>	<b>Definition Name</b>	<b>Usage</b>
<a href="#">Job Opening Template Page</a>	HRS_JO_TMPL_DESCR	Identify job opening templates.
<a href="#">Template Structure Page</a>	HRS_JO_TMPL_STRUCT	Configure the availability and organization of job opening data.

## Understanding Job Opening Templates

Job opening templates control the content and organization of sections on the Job Opening page. The template organizes job opening data into *pages* and *sections*. The template definition includes names that you choose for the pages; the sections, however, have fixed names that you cannot change.

### Job Opening Template Pages

In a job opening template, a *page* is the high-level organizational element for job opening data.

At runtime, the system renders template pages differently depending on whether the user is adding a new job opening or accessing an existing job opening:

- If a user is creating a new job opening, the template pages appear as tabs on the Job Opening page.
- If a user accesses an existing job opening, template pages are rendered as section links under the Job Opening Details tab.

After a job opening is created, the Job Opening page has additional tabs for managing applicants and tracking recruiting activities. Therefore, the actual job opening data is consolidated under a Job Opening Details tab, and the template pages are pushed down one level in the display hierarchy.

In the following examples, the job opening template defines five pages: Job Details, Qualifications, Screening, Job Postings, and Hiring Team. The first image shows the Job Opening page during the job opening creation process. The second image shows the Job Opening page after the job opening is created.

This illustration shows the five pages from the job opening template rendered as tabs on the Job Opening page during the job opening creation process.

This illustration shows the five pages from the job opening template rendered as subsections of the Job Opening Details tab on the Job Opening page, after the job opening has been created.

## Job Opening Template Sections

The first section in the first page of every template is the delivered *Job Information* section. This contains basic information about the opening (the job opening type, the date opened and the target fill date, the number of openings to be filled, and so forth) and the actual job (job code, business unit, company, department, location, and so forth)

See [Job Opening Page: Opening Information Section](#).

The rest of the template is user-configured. You can add all sections to the first template page (after the Job Information section), or you can create additional template pages, organized according to your needs. For each template page in the template definition, you list one or more sections that appear on that page.

The choices that appear in the section drop-down list box come from two sources.

- Profile content types.

There are sections for those profile content types that are available for use in Talent Acquisition Manager. These are the content types that are included in the system's primary person profile type (as defined on the Assign Profile Type Defaults page).

For example, the primary person profile includes content types for competencies, languages, and licenses & certifications, those all appear as section choices.

- Predefined recruiting sections.

Talent Acquisition Manager includes several predefined recruiting-specific sections. Some of these predefined sections are job-related, others relate to screening, and still others are used to identify members of the hiring team.

The following table lists the predefined sections:

<b>Section Name in Template Definition</b>	<b>Section Contents</b>	<b>Section on Job Opening Page</b>
Education and Experience.	A matrix showing how much experience is required for candidates with differing levels of education.	<a href="#">Job Opening Page: Work Experience &amp; Education Section</a>
Job Information. <hr/> <b>Note:</b> This is required to be the first section on the first page in the template. <hr/>	Basic information about the job opening.	<a href="#">Job Opening Page: Opening Information Section</a>
Job Postings.	A list of existing job postings and links for creating or modifying job postings.	<a href="#">Job Opening Page: Job Postings Section</a>
Profile Details. <hr/> <b>Note:</b> This option is available only if profile integrations is activated on the Recruiting Installation - General page. <hr/>	A list of profiles that are associated with the job opening.	<a href="#">Job Opening Page: Profile Combination Section</a>
Salary Information.	Salary information such as the salary plan, salary grade and step ranges, salary range, pay frequency, and currency.	<a href="#">Job Opening Page: Salary Information Section</a>
Screening Options.	A list of screening levels, and fields for defining certain screening processing rules.	<a href="#">Job Opening Page: Applicant Screening Section</a>
Skills and Employment Questions.	A list of skills and employment related questions.	<a href="#">Job Opening Page: Screening Questions Section</a>
Staffing Information.	Job information such as the full-time/part-time, regular/temporary, begin and end dates, work period and the hours worked per work period, and travel percentage.	<a href="#">Job Opening Page: Staffing Information Section</a>

<b>Section Name in Template Definition</b>	<b>Section Contents</b>	<b>Section on Job Opening Page</b>
Works Council Information.	<p>A Works Council ID field for identifying the works council for the job opening. This is not an entire section on the Job Opening page, it's a single field in the Opening Information section.</p> <p>The Works Council section is only available for selection if you select the <b>Optional Works Council</b> option on the Recruiting Installation - General page.</p>	<u>Job Opening Page: Opening Information Section</u>
Recruiter Assignments. Hiring Manager Assignments. Interviewer Assignments. Interested Party Assignments. Screening Notification Team.	A list of assignees or team members.	<u>Job Opening Page: Assignments Sections</u>

Within a recruitment template, the resume template needs to coordinate with the job opening template. Otherwise, there can be a mismatch between the information applicants enter when they apply for jobs online. For example, if a job opening template includes a section for screening questions, the resume template must also include the *Online Questionnaire* section so that applicants can answer the questions.

See [Understanding Recruitment Templates](#).

## Order of Job Opening Template Sections

At runtime, the Job Opening page displays sections from the job opening template in a predefined order, not in the order specified in the template. The only way to adjust the order is by putting sections on different pages and then putting the pages in the desired order.

This is the order in which sections appear on a page:

1. *Job Information*
2. *Works Council Information*
3. *Profile Details*
4. A scroll area, *Additional Job Specifications*, containing these sections:
  - a. *Staffing Information*
  - b. *Salary Information*
  - c. *Education and Experience*

- d. All profile content types.  
Content types are alphabetized according to their identifier (which is not visible on the Job Opening page) rather than by their description. For example, the delivered *Current Location* content type has the identifier *LOCATION*, so it is alphabetized under *L* rather than under *C*.
  - e. *Skills Questions* and *Employment Questions*
  - f. *Screening Options*
5. A group box, *Assignments*, containing these sections:
- a. *Recruiter Assignments*
  - b. *Hiring Manager Assignments*
  - c. *Interviewer Assignments*
  - d. *Interested Party Assignments*
  - e. The *Screening Notification Team* section.
6. *Job Postings*

---

**Note:** The *Additional Job Specifications* scroll area can have multiple rows if the system is configured to permit more than one job code or position per job opening. The sections in this scroll area can therefore vary for the different job codes in the job opening. When the system does not permit more than one job code per job opening, the scroll area is still visible, but it never has more than a single row of data.

---

See [Recruiting Installation – Jobs Page](#).

## Prerequisites

For the Works Council Information section to appear as an option in the job opening template, you must select the **Optional Works Council** option on the Recruiting Installation - General page.

See [Recruiting Installation - General Page](#).

## Job Opening Template Page

Use the Job Opening Template page (HRS\_JO\_TMPL\_DESCR) to identify job opening templates.

Navigation:

**Set Up HCM > Product Related > Recruiting > Templates > Job Opening Template > Job Opening Template**



This example illustrates the Job Opening Template page.

[New Window](#) | [Help](#) | [Personalize Page](#)

Job Opening Template

Template Structure

### Job Opening Template

Job Opening Template ID

\*Status

Status Date

\*Description

\*Short Description

Save

Return to Search

Notify

Add

Update/Display

Job Opening Template | [Template Structure](#)

<i>Field or Control</i>	<i>Description</i>
<b>Job Opening Template ID</b>	Template IDs are automatically assigned when you create the template.
<b>Status</b> and Status Date	Indicate whether the definition is <i>Active</i> or <i>Inactive</i> and the date that the status was assigned. Only active templates are available for selection in recruitment templates. The system displays a warning if you attempt to inactivate a template that is used in a recruitment template.
<b>Description</b>	Enter an identifying name for this template. A descriptive name helps you when you reference the template from within a recruitment template.

## Template Structure Page

Use the Template Structure page (HRS\_JO\_TMPL\_STRUCT) to configure the availability and organization of job opening data.

Navigation:

**Set Up HCM > Product Related > Recruiting > Templates > Job Opening Template > Template Structure**

This example illustrates the Template Structure page.

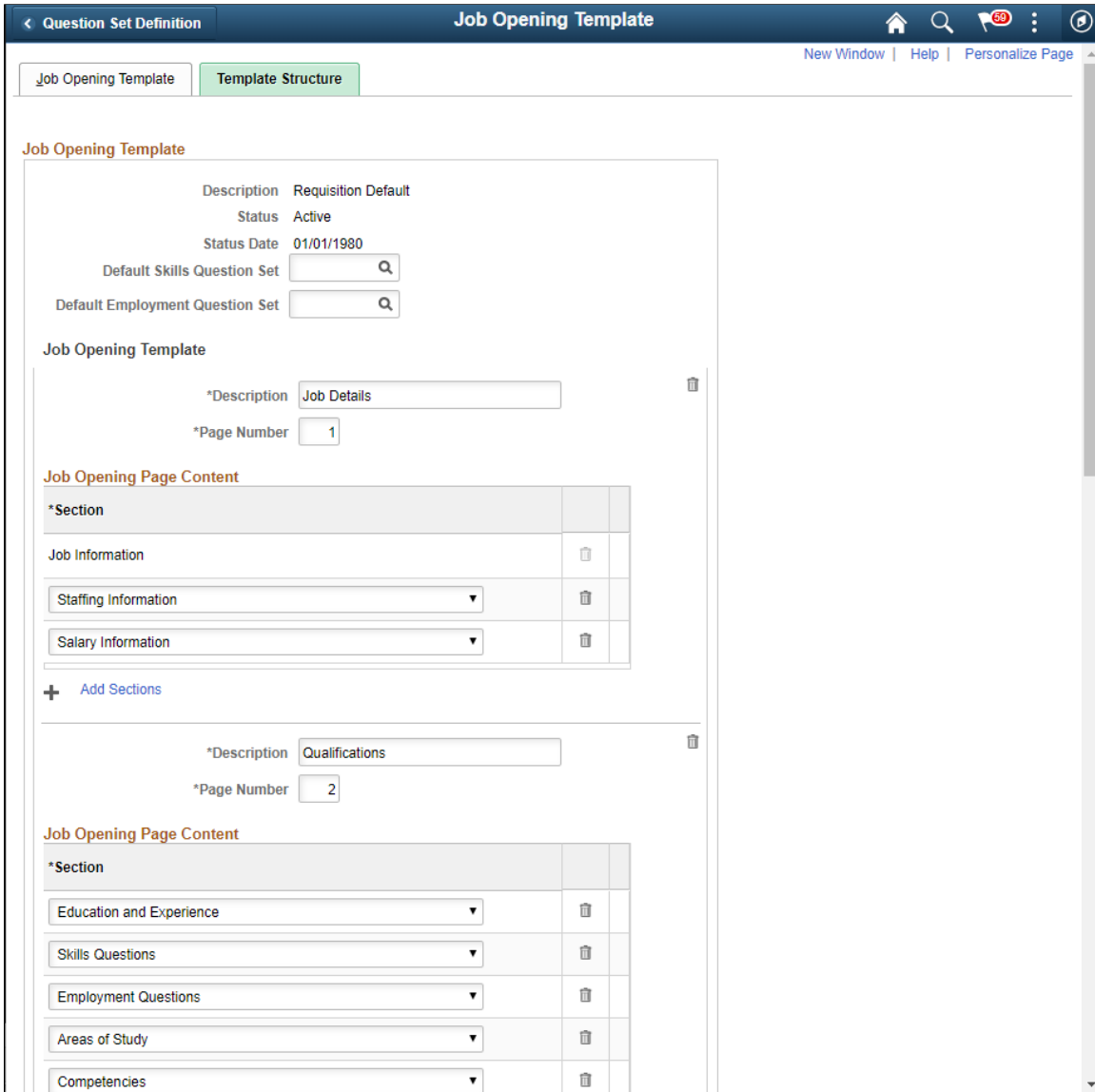

**Note:** This illustration shows only part of the page.

<b>Field or Control</b>	<b>Description</b>
<b>Default Skills Question Set</b>	<p>Optionally, enter a Skills question set whose questions will be automatically loaded into job openings that you create using this template. Users can still add and remove questions from the job opening, this option simply streamlines data entry when you use a standard set of Skills questions for all job openings based on the template.</p> <p>Changes made to the Skills question set, or the association of a different question set ID with the template, will not impact job openings that have already been created. Any changes to the template or the Skills question set will apply to new job openings only.</p> <hr/> <p><b>Note:</b> When a job opening is cloned, the new job opening does not load Skills questions from this default question set. Instead, the system copies the Skills questions from the original job opening.</p> <hr/>
<b>Default Employment Question Set</b>	<p>Optionally, enter an Employment question set whose questions will be automatically loaded into job openings that you create using this template. Users can still add and remove questions from the job opening, this option simply streamlines data entry when you use a standard set of Employment questions for all job openings based on the template.</p> <p>Changes made to the Employment question set, or the association of a different question set ID with the template, will not impact job openings that have already been created. Any changes to the template or the Employment question set will apply to new job openings only.</p> <hr/> <p><b>Note:</b> When a job opening is cloned, the new job opening does not load Employment questions from this default question set. Instead, the system copies the Employment questions from the original job opening. You cannot have a question that exists both in the Skills Question set and Employment Question set</p> <hr/>

## Job Opening Template

<b>Field or Control</b>	<b>Description</b>
<b>Description</b>	Enter a title for the template page. This title appears on the corresponding tab (when creating a job opening) or tab section (when accessing an existing job opening).
<b>Page Number</b>	Enter a sequence number for the template page. This controls the order in which the tabs or tab sections appear on the Job Opening page.

<i>Field or Control</i>	<i>Description</i>
<b>Add Pages</b>	This link appears at the bottom of the Job Opening Template page, after all existing page definitions. Click to add another template page at the bottom of the Template Structure page. (There is no scroll area for the template pages; they appear in one long list.)

### Job Opening Page Content

Use this grid to list the sections to be included in the template page.

<i>Field or Control</i>	<i>Description</i>
<b>Section</b>	<p>Select the section or sections that you want included on this page. Values in the drop-down list box include both predefined recruiting sections and profile content types that have been configured for recruiting use.</p> <hr/> <p><b>Note:</b> The Job Information section is always the first section on the first template page, where it appears in a read-only grid row</p> <hr/>
<b>Add Sections</b>	<p>Click to add another section to the template page. A blank row appears in the Job Opening Page Content grid.</p> <p>On any particular page of the job opening template, the included sections appear in a predefined order, not in the order specified in the template.</p> <p>See <a href="#">Understanding Job Opening Templates</a>.</p>

---

## Setting Up Job Opening Posting Templates

To set up job opening posting templates, use the Job Opening Posting (HRS\_JO\_PST\_TMPL) component.

### Page Used to Set Up Job Opening Posting Templates

<i>Page Name</i>	<i>Definition Name</i>	<i>Usage</i>
<a href="#">Posting Template Page</a>	HRS_JO_PST_TMPL	Create a job opening posting template.

## Understanding Job Opening Posting Templates

Job opening posting templates control which sections, or *posting description types* are available to include in a job posting.

Posting description types are categories of information that you can assemble when constructing a job posting. For example, your organization might have posting description types such as Qualifications, Responsibilities, and How to Apply.

When you define a job opening posting template, you select from the posting description types that you set up on the Posting Description Type page.

### Related Links

[Posting Description Type Page](#)

## Prerequisites

Before you can set up a job posting template, define posting description types.

See [Setting Up the Job Posting Description Library](#).

## Posting Template Page

Use the Posting Template page (HRS\_JO\_PST\_TMPL) to create a job opening posting template.

Navigation:

**Set Up HCM > Product Related > Recruiting > Templates > Job Opening Posting Template > Posting Template**

This example illustrates the Posting Template page.

### Posting Template

**Template Details**

Job Opening Posting ID 1000

Status Active ▼

Status Date 01/01/1980 31

\*Description

Short Description

**Requisition Pages to Include**

Selected	Description	Seq Nbr
<input type="checkbox"/>	Basis of Rating	<input style="width: 50px;" type="text"/>
<input type="checkbox"/>	Closing Statement	<input style="width: 50px;" type="text"/>
<input type="checkbox"/>	Conditions of Employment	<input style="width: 50px;" type="text"/>
<input checked="" type="checkbox"/>	Department Marketing Statement	<input style="width: 50px;" type="text" value="1"/>
<input type="checkbox"/>	Equal Employment Opportunity	<input style="width: 50px;" type="text"/>
<input type="checkbox"/>	How CTAP &/or ICTAP May Apply	<input style="width: 50px;" type="text"/>
<input checked="" type="checkbox"/>	How To Apply	<input style="width: 50px;" type="text" value="5"/>
<input type="checkbox"/>	How to Claim Vet Preference	<input style="width: 50px;" type="text"/>
<input checked="" type="checkbox"/>	Org Marketing Statement	<input style="width: 50px;" type="text" value="4"/>
<input type="checkbox"/>	Other Information	<input style="width: 50px;" type="text"/>
<input type="checkbox"/>	Pay, Benefits & Work Schedule	<input style="width: 50px;" type="text"/>
<input checked="" type="checkbox"/>	Qualifications	<input style="width: 50px;" type="text" value="2"/>
<input checked="" type="checkbox"/>	Responsibilities	<input style="width: 50px;" type="text" value="3"/>
<input type="checkbox"/>	Who May Apply	<input style="width: 50px;" type="text"/>

### Template Details

<i>Field or Control</i>	<i>Description</i>
<b>Job Opening Posting ID</b>	Template IDs are automatically assigned when you create the template.

<b>Field or Control</b>	<b>Description</b>
<b>Status</b> and Status Date	Indicate whether the definition is <i>Active</i> or <i>Inactive</i> and the date that the status was assigned. Only active templates are available for selection in recruitment templates. The system displays a warning if you attempt to inactivate a template that is used in a recruitment template.
<b>Description</b>	Enter an identifying name for this template. A descriptive name helps you when you reference the template from within a recruitment template.

## Requisition Pages to Include

This grid lists all active posting description types.

<b>Field or Control</b>	<b>Description</b>
<b>Selected</b>	Select this check box for each posting description type that you want to include in the job posting.
<b>Seq Nbr</b> (sequence number)	Enter the order in which you want the posting description type to appear in the job posting.

---

## Setting Up Screening Templates

To set up screening templates, use the Screening Template (HRS\_SCREEN\_TMPL) component.

### Page Used To Set Up Screening Templates

<b>Page Name</b>	<b>Definition Name</b>	<b>Usage</b>
<a href="#">Screening Template Page</a>	HRS_SCREEN_TMPL	Create a screening template.

## Understanding Screening Templates

Use screening templates to define default screening options that the system applies to job openings that are associated with the template. The default settings include a list of screening levels, the order in which the screening levels are processed, and whether applicants must pass the previous level in order to be processed by the next screening level.

For U.S. Federal agencies, there are also default settings related to score augmentation, veterans preferences, tie breakers, and candidate ranking. The template does not, however, include transmutation settings, which are configured in individual job openings.

**Note:** Screening templates do *not* include specific screening criteria. The criteria is job-specific and therefore must be configured in the Job Opening component.

## Prerequisite

Before you begin to set up screening templates, define the screening levels that you want to include in the template.

See [Setting Up Screening Level Definitions](#).

## Screening Template Page

Use the Screening Template page (HRS\_SCREEN\_TMPL) to create a screening template.

Navigation:

**Set Up HCM > Product Related > Recruiting > Templates > Screening Template > Screening Template**

This example illustrates the Screening Template page.

**Screening Template**

**Screening Definition**

\*Status: Active | Screening Template ID: 1000

\*Description: Full Screening Commercial

Short Description: Full

Max Total Points: 100

Must Pass Previous Levels

**Screening Levels**

*Sequence number	Screening ID	Description		
1	Pre Screening	Pre Screen	+	-
2	Online Screening	Online Scr	+	-
3	Preliminary		+	-
4	Final		+	-

Buttons: Save, Return to Search, Notify, Add, Update/Display



This example illustrates the Screening Template page in a US Federal system.

### Screening Template

**Screening Definition**

\*Status Active Screening Template ID 1000

\*Description

Short Description

Max Total Points

Must Pass Previous Levels

**Federal**

Raw Augmented Score Limit  Raw Veterans Pref Score Limit

Tie Break Number

**Competitive**

Rank Candidates of Category 1       Rank Candidates of Category 2

Rank Candidates of Category 3       Rank Candidates of Category 4

Veteran Preferred in Tie Break

**Non-competitive**

Rank Candidates of Category 1       Rank Candidates of Category 2

Rank Candidates of Category 3       Rank Candidates of Category 4

Veteran Preferred in Tie Break

**Screening Levels** Personalize | Find | |  First 1-4 of 4 Last

*Sequence number	Screening ID	Description		
1	Pre Screening	Pre Screen	+	-
2	Online Screening	Online Scr	+	-
3	<span>Preliminary</span>		+	-
4	<span>Final</span>		+	-

**Note:** The settings on this page are default settings that the system uses for job openings that are associated with this template. Everything that you configure here can be changed in the Job Opening component.

### Screening Definition

<i>Field or Control</i>	<i>Description</i>
<b>Screening Template ID</b>	Template IDs are automatically assigned when you create the template.

<b>Field or Control</b>	<b>Description</b>
<b>Status</b>	Indicate whether the definition is <i>Active</i> or <i>Inactive</i> . Only active templates are available for selection in recruitment templates. The system displays a warning if you attempt to inactivate a template that is used in a recruitment template.
<b>Description</b>	Enter an identifying name for this template. A descriptive name helps you when you reference the template from within a recruitment template.
<b>Max Total Points</b> (maximum total points)	Enter the maximum points that an applicant can accumulate across all screening levels. During the applicant ranking process in U.S. federal implementations, the Rank Applicants page shows applicants' final scores both as numbers and as a percentage of the value you enter here, which is typically <i>100</i> .
<b>Must Pass Previous Levels</b>	<p>Select this check box if the applicant must pass the previous screening level before being evaluated for the next screening level.</p> <p>This setting does not apply to:</p> <ul style="list-style-type: none"> <li>• The first screening level, as indicated by the lowest sequence number.</li> <li>• Prescreening or online screening levels.</li> </ul> <p>Prescreening is always the first screening level anyway. Online screening can be preceded by prescreening (although the best practice is to use only one or the other in a job opening), but because failing prescreening stops the online application process, applicants cannot even reach the online screening level without passing any preliminary prescreening.</p>

**(USF) Federal**

<b>Field or Control</b>	<b>Description</b>
<b>Raw Augmented Score Limit</b>	Enter the total number of augmentation points that can be awarded. You can configure screening to award augmentation points for certain competencies or accomplishments that are not required for the position but may be given consideration in the selection process.

<b>Field or Control</b>	<b>Description</b>
<b>Raw Veterans Pref Score Limit</b> (raw veterans preference score limit)	Enter the maximum number of points that can be added to an applicant's final screening score for veterans preference. The number that you enter overrides veterans preference score higher than the limit.
<b>Tie Break Number</b>	Enter a random number to use in the tie-breaking algorithm for ranking applicants.

## (USF) Competitive and Non-Competitive

The same fields appear in the Competitive and Non-Competitive group boxes so that you can separately configure ranking options for competitive and noncompetitive applicants.

<b>Field or Control</b>	<b>Description</b>
<b>Rank Candidates of Category 1, Rank Candidates of Category 2, Rank Candidates of Category 3, and Rank Candidates of Category 4</b>	<p>At the end of the applicant screening process, score thresholds are applied to classify the candidates as qualified, well-qualified, or best-qualified. The system then considers these qualification classifications along with the applicants's priority processing status and places applicants in these four categories:</p> <ul style="list-style-type: none"> <li>• Category 1: Qualified, well qualified, and best qualified applicants with <i>Must Select</i> priority placement.</li> <li>• Category 2: Well qualified and best qualified applicants with <i>Must Consider</i> priority placement.</li> <li>• Category 3: Best qualified applicants with no priority placement.</li> <li>• Category 4: Qualified and well qualified applicants with no priority placement.</li> </ul> <p>Select check boxes for each category of applicants that are to be included in the final applicant ranking that produces the Certificate of Eligibles.</p> <p>See <a href="#">Understanding Priority Placement Processing</a>.</p>
<b>Veteran Preferred in Tie Break</b>	Select this check box if you want applicants with veteran status to win tiebreakers during the ranking process.

## Screening Levels

Use this grid to add screening levels to the template.

<b>Field or Control</b>	<b>Description</b>
<b>Sequence number</b>	Assign each screening level an order number. This, in turn, becomes the default order of the screening levels in the job opening.  Screening levels for prescreening and online screening always appear first (prescreening before online screening if both exist). You cannot change the order for these screening levels.
<b>Screening ID</b>	Select the screening level definitions that you want to include in the template

## Setting Up Interview Evaluation Templates

To set up interview evaluation templates, use the Interview Evaluation Templates (HRS\_INT\_EVL\_DFN) component.

### Pages Used to Set Up Interview Evaluation Templates

<b>Page Name</b>	<b>Definition Name</b>	<b>Usage</b>
<a href="#">Interview Evaluation Template Page</a>	HRS_INT_EVL_DFN	Create an interview evaluation template.
<a href="#">Recommendation Reasons Page</a>	HRS_INTEVL_RSN_SEC	Select reasons (for a specific interview status) to make available to interviewers when they complete an interview evaluation.

## Understanding Interview Evaluation Templates

Interview evaluation templates define three aspects of the form that interviewers use to enter interview evaluations:

- Evaluation categories.

These are the different aspects of an applicant that the interviewer evaluates. For example, the interviewer might evaluate the applicant's communication skills, technical skills, and work experience.

On the interview template, you review all available categories and select which ones to include in the evaluation form.

- Ratings.

Interviewers evaluate applicants using a rating scale that you configure especially for this purpose.

On the interview template, you review all available ratings and select which ones to make available in the evaluation form.

- Recommendations.

Interviewers make recommendations using statuses for the interview recruitment areas. On the interview template, you review these statuses and select which ones to make available as recommendation options. For each status, you also choose which associated reasons to make available.

## Related Links

[Completing Interview Evaluations](#)

## Prerequisites

Before you to set up interview evaluation templates, you must set up:

1. Interview evaluation categories.
2. Interview evaluation ratings.

See [Setting Up Interview Definitions](#).

## Interview Evaluation Template Page

Use the Interview Evaluation Template page (HRS\_INT\_EVL\_DFN) to create an interview evaluation template.

Navigation:

**Set Up HCM > Product Related > Recruiting > Templates > Interview Evaluation Template > Interview Evaluation Template**

This example illustrates the Interview Evaluation Template page.

### Interview Evaluation Template

Template ID 1000  
 \*Description  Short Description   
 \*Status  Status Date 08/10/2004

**Evaluation Categories** Personalize | View All | First 1-4 of 4 Last

Evaluation Category		
Communication Skills	<input type="button" value="+"/>	<input type="button" value="-"/>
Education/Training	<input type="button" value="+"/>	<input type="button" value="-"/>
Work Experience	<input type="button" value="+"/>	<input type="button" value="-"/>
Technical Skills	<input type="button" value="+"/>	<input type="button" value="-"/>

**Recommendation** Personalize | View All | First 1-5 of 5 Last

Use	Status Code	Description		Reason Required
<input checked="" type="checkbox"/>	005	005 Interview	Reasons	<input type="checkbox"/>
<input checked="" type="checkbox"/>	020	020 Make Offer	Reasons	<input type="checkbox"/>
<input checked="" type="checkbox"/>	100	100 Hold	Reasons	<input type="checkbox"/>
<input checked="" type="checkbox"/>	110	110 Reject	Reasons	<input checked="" type="checkbox"/>
<input checked="" type="checkbox"/>	120	120 Withdrawn	Reasons	<input type="checkbox"/>

**Rating Scale** Personalize | View All | First 1-3 of 3 Last

Use	Rating	Score
<input checked="" type="checkbox"/>	Excellent	2
<input checked="" type="checkbox"/>	Average	1
<input checked="" type="checkbox"/>	Not Qualified	0

<b>Field or Control</b>	<b>Description</b>
<b>Template ID</b>	Template IDs are automatically assigned when you create the template.
<b>Description</b>	Enter an identifying name for this template A descriptive name helps you when you reference the template from within a recruitment template.

<b>Field or Control</b>	<b>Description</b>
<b>Status</b>	<p>Indicate whether the definition is <i>Active</i> or <i>Inactive</i>.</p> <p>Only active templates are available for selection in recruitment templates. The system displays a warning if you attempt to inactivate a template that is used in a recruitment template.</p>

## Evaluation Categories

<b>Field or Control</b>	<b>Description</b>
<b>Evaluation Category</b>	Select an evaluation category that you want included in the interview evaluation. Evaluation categories are created on the Interview Evaluation Category page.
<b>Create New Category</b>	Click to access the Interview Evaluation Category page in Add New mode so that you can add additional categories to the system.

## Recommendation

<b>Field or Control</b>	<b>Description</b>
<b>Use and Status Code</b>	<p>Select the <b>Use</b> check box for a status code to make that status available as a recommendation on the interview evaluation form.</p> <p>Status codes are defined on the Status Effects page. The system automatically lists the status values that are defined for the interview recruitment area.</p>
<b>Reasons</b>	Click to access the Recommendation Reasons page, where you can choose which status reasons to make available on the evaluation form that interviewers use. The page lists all reasons (if any) that exist for the associated interview status.
<b>Reasons Required</b>	<p>Select this check box if you require interviewers to select an interview reason when they select the interview status value on the evaluation form. If you select this check box, confirm that there are, in fact, reasons associated with the indicated status.</p> <p>Interview reasons are defined on the Statuses and Reasons page.</p>

## Rating Scale

<i>Field or Control</i>	<i>Description</i>
<b>Use and Rating</b>	Select the <b>Use</b> check box for a rating to make that rating available as on the interview evaluation form.  Ratings are defined on the Interview Evaluation Rating page. The system automatically lists all existing ratings.
<b>Score</b>	Displays the number of points that are associated with the rating.
<b>Create New Rating</b>	Click to access the Interview Evaluation Ratings page in Add New mode so that you can add additional ratings to the system.

## Related Links

[Setting Up Recruiting Statuses](#)

[Completing Interview Evaluations](#)

## Recommendation Reasons Page

Use the Recommendation Reasons page (HRS\_INTEVL\_RSN\_SEC) to select reasons (for a specific interview status) to make available to interviewers when they complete an interview evaluation.

Navigation:

Click the **Reasons** link on the Interview Evaluation Template page.

This example illustrates the Recommendation Reasons page.

**Recommendation Reasons**

Status Code 110 Reject

Reasons		
Use	Status Reason	Description
<input checked="" type="checkbox"/>	010	Insufficient Experience
<input checked="" type="checkbox"/>	020	Insufficient Skills



<i>Field or Control</i>	<i>Description</i>
Use and Status Reason	Select the <b>Use</b> check box for a status reason to make that reason available as a recommendation on the interview evaluation form.

## Setting Up Recruitment Templates

To set up recruitment templates, use the Recruitment Template (HRS\_RCRT\_TMPL) component.

### Pages Used to Set Up Recruitment Templates

<i>Page Name</i>	<i>Definition Name</i>	<i>Usage</i>
<u>Recruitment Template Page</u>	HRS_RCRT_TMPL	Link templates to recruitment templates.
<u>Segmentation Values Page</u>	HRS_SEGMENT_SEC	Assign segmentation values to recruitment templates.

## Understanding Recruitment Templates

Recruitment templates link all the recruiting templates together. Newly created job openings are automatically linked to a recruitment template, and all templates that are assigned to that recruitment template are then used by that job opening.

Specific sections on the job opening template need to be coordinated with the sections on the resume template. When you save the recruitment template, the system checks for these sections in the job opening template and verifies that the corresponding sections are included in the resume template.

When a mismatch occurs between the two templates, a warning message appears. You can cancel to correct the problem, or you can save the recruitment template with the mismatched information.

### Cross-Template Validations

The following table identifies the sections that need to be coordinated to avoid a validation error:

<b>Section in Job Opening Template</b>	<b>Corresponding Sections in Resume Template</b>
Education and Experience	<ul style="list-style-type: none"> <li>• Education History,</li> <li>• Work History</li> <li>• Training</li> </ul> <hr/> <p><b>Note:</b> All three of these section should be in the resume template if the Education and Experience section is in the job opening template.</p> <hr/>
Screening Question	Online Questionnaire
<Profile Content Types>	<p>All profile-based sections must match up. The section names are the same in the resume template as they are in the job opening template.</p> <p>The delivered profile configuration includes these 18 profile-based sections: Areas of Study, Competencies, Current Location, Degrees, E&amp;G Special Projects, Elements, Geographic Preferences, Honors and Awards, International Preferences, Language Skills, Licenses &amp; Certifications, Location Preferences, Memberships, Responsibilities, School Education, Special Projects, Tests/Examinations, and Travel Preferences.</p>

## Job Opening Template Sections That Aren't Validated Against the Resume Template

The following sections in the job opening template are *not* validated against the resume template:

- *Job Information, Salary Information, and Staffing Information.*

Some of the fields in these job opening sections have equivalents in the resume template's *Preferences* section, but the system does not perform any validations related to these sections.

- *Profile Details.*

This section shows which person and job profiles provided data for the qualifications sections in the job opening, so it is not related to any data that you would collect from applicants.

- *Screening Options.*

This section is for setting up the screening rules for the job opening, so it is not related to any data that you would collect from applicants.

- *Job Postings.*

This section is for creating and posting job descriptions, so it is not related to any data that you would collect from applicants.

- The assignment-related sections: *Hiring Manager Assignments*, *Interested Party Assignments*, *Interviewer Assignments*, *Recruiter Assignments*, and *Screening Notification Team*

This section is for identifying employees who are on the hiring team for the job opening, so it is not related to any data that you would collect from applicants.

- *Works Council Information*.

This section is for associating a works council with the job opening, so it is not related to any data that you would collect from applicants.

## Resume Template Sections That Aren't Validated Against the Job Opening Template

The following sections in the resume template are *not* validated against the job opening template:

- *Preferences* and *Federal Preferences*, and *Federal Priority Placement*.

Some of the fields in these resume sections have equivalents in the *Job Information* section of the job opening template. The *Job Opening* section is required in all job opening templates, so no validation is necessary.

- *Personal Information*, *References*, and *Referrals*.

These sections contain general applicant data that is not related to any job openings data.

## Prerequisites

Before you define recruitment templates, define the templates that will be referenced from the recruitment template.

Refer to these topics for more information:

- [Setting Up Resume Templates](#)
- [Setting Up Job Opening Templates](#)
- [Setting Up Job Opening Posting Templates](#)
- [Setting Up Screening Templates](#)
- [Setting Up Interview Evaluation Templates](#)
- [Setting Up Flexible Process Templates and Template Groups](#)
- [Setting Up Employee Referral Programs](#)

## Recruitment Template Page

Use the Recruitment Template page (HRS\_RCRT\_TMPL) to link templates to recruitment templates.

Navigation:

**Set Up HCM > Product Related > Recruiting > Templates > Recruitment Template > Recruitment Template**

This example illustrates the Recruitment Template page.

## Templates

<b>Field or Control</b>	<b>Description</b>
<b>Standard Requisition</b>	Select this check box to make the template available for use with job openings that are standard requisitions.
<b>Continuous Job Posting</b>	Select this check box to make the template available for use with job openings that are continuous job postings.
<b>Resume Template ID</b>	Select the resume template that you want to link to this recruitment template.
<b>Job Opening Template ID</b>	Select the job opening template that you want to link to this recruitment template.

<b>Field or Control</b>	<b>Description</b>
<b>Job Opening Posting ID</b>	Select the job opening posting template that you want to link to this recruitment template.
<b>Screening Template ID</b>	Select the screening template that you want to link to this recruitment template.
<b>Employee Referral Program</b>	Select the employee referral program that you want to link to this recruitment template.
<b>Interview Evaluation Template</b>	Select the interview evaluation template that you want to link to this recruitment template.
<b>Flexible Template Group ID</b>	Select the flexible template group that you want to link to this recruitment template.
<b>Load Rqmts from Job Profile</b> (load requirements from job profile)	<p>Select a source from which the system pulls profile content into a new job opening. The options are:</p> <ul style="list-style-type: none"> <li>• <i>Not Used</i></li> <li>• <i>Job Code</i></li> <li>• <i>Job Family</i></li> <li>• <i>Position</i></li> <li>• <i>Salary Grade</i></li> </ul> <p>If you select an option other than <i>Not Used</i>, the system looks for a job profile that is associated with the indicated object. For example, if you select <i>Job Code</i>, then when a user creates a new job opening, the system looks for a job profile that is associated with the job code entered on the Primary Job Opening Information page. If one is found, the content items from that profile are imported into the new Job Opening.</p> <hr/> <p><b>Important!</b> This settings is used only if profile integration is active on the Recruiting Installation component. Data that is automatically imported as a result of this setting is in addition to data imported from profiles that users explicitly identify on the Primary Job Opening Information page.</p> <hr/>
<b>Segmenting Values</b>	Click to display the Segmenting Values page, where you can identify specific subsets of your job openings that use this template.

## Segmentation Values Page

Use the Segmentation Values page (HRS\_SEGMENT\_SEC) to assign segmentation values to recruitment templates.

Navigation:

Click the **Segmenting Values** link on the Recruitment Template page.

This example illustrates the Segmentation Values page.









**Recruitment Template**

---

**Segmentation Values**

Recruitment Template ID Recruitment Template 100

Effective Date 07/05/2001

Segmentation Values		Personalize   Find      	First  1-2 of 2  Last
Job Family	Description		
KADMIN 	Administrative Support		
KCLERK 	Clerical		

[Add Job Family](#)

Save
Cancel

## Segmentation Values

<b>Field or Control</b>	<b>Description</b>
<Segmentation Value>	<p>The contents of this grid, and therefore the label for the first column, depend on the how you've chosen to segment your templates (a choice you make in the Template Segmenting Type field on the <a href="#">Recruiting Installation - General Page</a>).</p> <p>List the segmentation values that use this recruitment template. For example, if you segment templates by job family, then list the job families that use this recruitment template. If you segment templates by department, use the grid to list the departments that use this template.</p> <p>When a user creates a job opening, the primary job data includes a field for the segmenting value. If the system finds a recruitment template with a segmentation value that matches the job opening, it applies that recruitment template to the job opening. For example, if the job opening is for the KADMIN job family, then a recruitment template that lists the KADMIN job family in the Segmentation Values grid is applied. If there are no such recruitment templates, the system applies the default recruitment template indicated on the Recruiting Installation - General page.</p>





# Setting Up Third Party Integrations

---

## Understanding Third Party Integrations

This topic provides overviews of:

- The open integration framework.
- Job board setup.
- Resume extractor setup.
- Background screener setup.

### Related Links

[Posting Jobs to PeopleSoft Services Procurement](#)

## The Open Integration Framework

Sharing job opening and candidate information is essential to the success of the recruitment process. PeopleSoft provides an open integration framework that enables you to integrate with:

- Staffing suppliers.
- Resume extractors.
- Background screening providers.

This generic open integration framework enables customers to integrate with any third party provider that they choose. For incoming data, the process is initiated by an incoming message. Using PeopleSoft PeopleTools Integration Broker, the open integration framework process reads the XML document contained in the message and uses the standard XSLT to transform the XML according to the vendor's specifications. Finally, the open integration framework maps the transformed data to the corresponding recruiting data and processes that information.

For outgoing data, a functional process such as posting a job opening or requesting a background screening check initiates the outgoing message. The process reads from the recruiting tables and uses data mapping to create an XML document. This initial XML document may be changed into to an HR-XML document. Another change is then applied to either the initial XML document or to the subsequent HR-XML document, depending on the supplier's needs, to create a final document. The final document is then sent using PeopleSoft PeopleTools Integration Broker

This diagram illustrates how the Open Integration Framework manages the exchange of information between PeopleSoft Recruiting Solutions and external service providers:

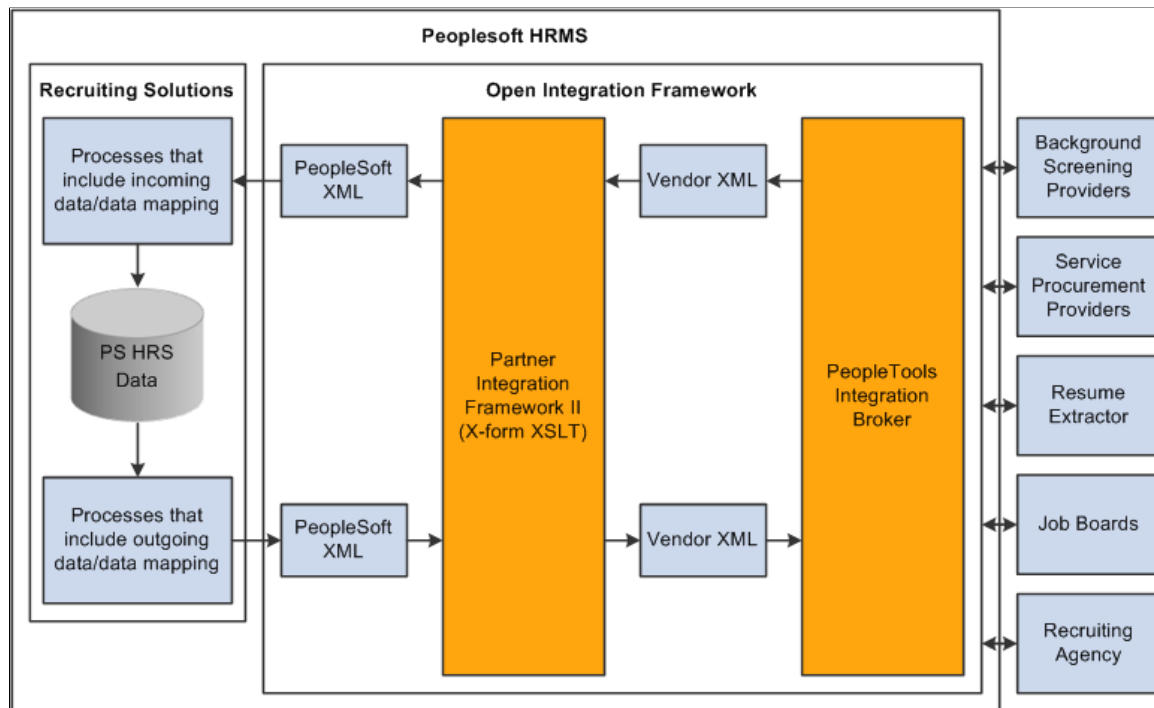

## Job Board Setup

Job board vendors enable you to post job openings to vendors such as job boards, services procurement providers, and recruitment agencies. To set up job board vendors:

1. Set up the job board vendor in the Vendor Setup component.
2. Set up a recruitment source in the Recruitment Sources component, and associate it with the vendor.
3. (Optional) Set up data mapping to support the recruitment source.

## Integration With PeopleSoft Service Procurement

Oracle delivers prebuilt integration points between Talent Acquisition Manager and PeopleSoft Service Procurement. The documentation for PeopleSoft Service Procurement provides detailed information about this integration and how to set it up. The integration requires those recruiting users who post jobs to Services Procurement to also be users of the Services Procurement system, with identical user IDs and passwords in both systems.

See [Posting Jobs to PeopleSoft Services Procurement](#).

## Resume Extractor Setup

Resume extractors enable users to start with a resume in electronic form (such as HTML, PDF, DOC, and so on) and have the information from that resume extracted into more meaningful data. Applicants might embed resumes in email messages as either text or an attachment, and then the resume extractor can process as much information as it can recognize and load data into the PeopleSoft applicant related

tables. Similarly, applicants can use their electronic resume to prepopulate their online job applications in PeopleSoft Candidate Gateway when they apply for jobs online. Recruiters can also use the extraction process to load data from resumes that they receive into the PeopleSoft applicant related tables. Finally, staffing providers can send resumes that require an extraction process.

To set up resume extractors:

1. Set up the resume extractor.  
Follow the vendor-provided instructions.
2. Set up the resume extractor vendor.

### Additional Setup Steps for Different Channels

Applicant resumes can come into the Recruiting Solutions system from one of several channels. The additional setup that you must complete to utilize resume extraction functionality varies slightly depending on the channels that the organization uses to receive resumes. For example, the additional setup that you must complete to receive resumes through email is different from the setup that you must complete to accept resumes from applicants who apply online through Candidate Gateway. However, the setup steps that you use to set up the actual resume extractor vendor are exactly the same for all channels. Therefore, you can set up a single resume extractor to use for all channels, or use a different resume extractor for each.

This table describes the setup steps for each channel:

<b>Step</b>	<b>Apply Online</b>	<b>Email</b>	<b>Open Integration Framework</b>	<b>Resume Load Process</b>
1	Set up a resume extractor (might be optional)	Set up a resume extractor (might be optional)	Set up a resume extractor (might be optional)	Set up a resume extractor (might be optional)
2	Set up a resume extractor vendor	Set up a resume extractor vendor	Set up a resume extractor vendor	Set up a resume extractor vendor
3	Set up a site	Set up an email server and email account to receive resumes	Set up a job board vendor	N/A
4	N/A	Set up an email node definition	N/A	N/A
5	N/A	Set up an email account	N/A	N/A
6	(Optional) Set up Marketing type recruitment sources	Set up a Vendor type recruitment source	Set up a Vendor type recruitment source	(Optional) Set up Marketing type recruitment sources

<b>Step</b>	<b>Apply Online</b>	<b>Email</b>	<b>Open Integration Framework</b>	<b>Resume Load Process</b>
7	(Optional) Create data mapping assignment for site	(Optional) Create data mapping assignment for recruitment source	(Optional) Create data mapping assignment for recruitment source	(Optional) Create data mapping assignment for recruitment source

**Note:** Step one might be optional because although an organization can set up and maintain a resume extractor locally, some resume extractor providers might want to set up and maintain the resume extractor remotely. Whether the step is optional depends on the agreement between the resume extractor provider and the organization.

## Background Screener Setup

Background screeners enable recruiters or managers to request formal background checks on applicants that are nearing completion of the recruitment process and are about to be hired. To set up background screeners:

1. Set up pre-employment vendors.
2. (Optional) Set up data mapping to support the pre-employment vendor.

## Setting Up Recruiting Vendors

To set up recruiting vendors, use the Vendor Setup (HRS\_VENDOR\_SETUP) component.

### Pages Used to Set Up Recruiting Vendors

<b>Page Name</b>	<b>Definition Name</b>	<b>Usage</b>
<u>Vendor Setup Page</u>	HRS_VENDOR_FILE	Load a new vendor configuration file, or view and modify details after loading a vendor configuration file.
<u>Pre-Employment Vendor Setup Page</u>	HRS_PREEMPL_VNDR	Define settings for pre-employment vendors.
<u>Integration Test Page</u>	HRS_VENDOR_TEST	Test vendor integration.

## Understanding How to Set Up Recruiting Vendors

Regardless of the type of recruiting vendor you are going to set up, you must complete some common tasks:

1. Set up your local gateway using PeopleTools Integration Broker.

See *PeopleTools: Integration Broker*

2. Verify security and class setup.

PeopleSoft delivers the permission list HCCPRS1010 and the role RS Technical Administrator for this purpose. To have full access to all integration components, the permission list must be linked to the menu HRS\_HROI.

3. Load the vendor-provided configuration file.

Work with the vendor to obtain this file.

4. (Optional) Map competencies, accomplishments, and postal codes from the vendor to PeopleSoft Recruiting Solutions.

Although data mapping is optional, it makes integration much more effective.

## Vendor Setup Page

Use the Vendor Setup page (HRS\_VENDOR\_FILE) to load a new vendor configuration file, or view and modify details after loading a vendor configuration file.

Navigation:

**Set Up HCM > Product Related > Recruiting > Integration > Recruiting Vendor > Vendor Setup**

This example illustrates the Vendor Setup page in Add a New Value mode.

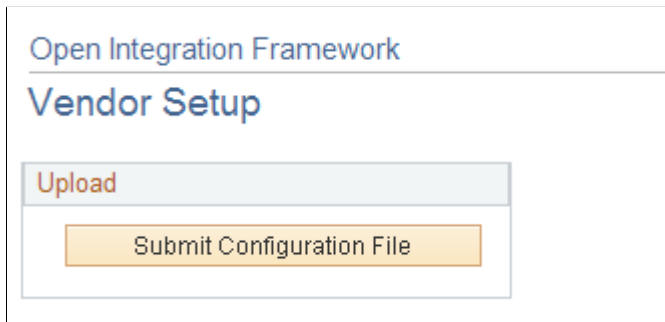

This example illustrates the Vendor Setup page after loading vendor configuration file.

Open Integration Framework

## Vendor Setup

Transaction Group JobBoard                      Version 1

**Vendor Setup**

\*Long Name                       \*Status

\*Short Name

Description

Filename                       [Submit File](#)

Allow Node Updates on Upload

[Vendor Administration](#)

Transactions			
Transaction	*Log Style	Node	Test
JobBoardUnpost	<input type="text" value="Log Everything"/>	HROI_6	<a href="#">Test</a>
JobBoardExpense	<input type="text" value="Log Everything"/>	HROI_7	<a href="#">Test</a>
JobBoardPost	<input type="text" value="Log Everything"/>	HROI_8	<a href="#">Test</a>
JobBoardStatus	<input type="text" value="Log Everything"/>	HROI_9	<a href="#">Test</a>
JobBoardUpdate	<input type="text" value="Log Everything"/>	HROI_10	<a href="#">Test</a>
SendCandidate	<input type="text" value="Log Everything"/>	HROI_11	<a href="#">Test</a>
VendorAdministration	<input type="text" value="Log Everything"/>	HROI_12	<a href="#">Test</a>

Transaction

Values	
Label	Value
Expense URL	<input type="text" value="http://rtdc78252qaemt.us.oracle.com:5000/PSIGW/Ht"/>
Candidate URL	<input type="text" value="http://rtdc78252qaemt.us.oracle.com:5000/PSIGW/Ht"/>
Expense URL	<input type="text" value="http://rtdc78252qaemt.us.oracle.com:5000/PSIGW/Ht"/>
Default Local Node	<input type="text" value="PSFT_HR"/>

## Upload

When you are adding a new vendor, the Vendor Setup page initially displays a single button.

<b>Field or Control</b>	<b>Description</b>
<b>Submit Configuration File</b>	Click to display a File Attachment dialog box, where you identify and upload the vendor's configuration file. After the system uploads the file, this button is hidden and the page instead displays page elements that you use to review and configure the vendor data.

## Vendor Setup Fields

When you access an existing vendor, or after you upload the configuration file for a vendor that you are adding, the page displays vendor setup fields.

The **Vendor Setup** and **Transactions** group boxes are automatically populated with the information that is provided in the configuration file. The transactions that appear in the **Transactions** group box are those that are defined on the Open Integration Framework - Transaction Group Setup page for the transaction group that is associated with the vendor configuration file.

## Vendor Setup

<b>Field or Control</b>	<b>Description</b>
<b>Status</b>	Indicate whether the vendor is <i>Active</i> or <i>Inactive</i> .
<b>Allow Node Updates on Upload</b>	The node definitions are set up by the process of loading the vendor configuration file. If subsequent loads of the file are necessary (perhaps a customer gets an updated configuration file from the vendor), the <b>Allow Node Updates on Upload</b> check box enables the user to update the node definition or keep allowing the nodes to be updated.
<b>Vendor Administration</b>	Click to access the vendor's administration page. Not all vendors will support this option.
<b>Extended Setup</b>	Click to access the Pre-Employment Vendor Setup page, where you can define settings for pre-employment vendors. This link appears only for vendors in the PreEmployment transaction group, based on the setup in the <b>Extension Configuration</b> group box on the Open Integration Framework - Transaction Group Setup page.

## Transactions

<b>Field or Control</b>	<b>Description</b>
<b>Log Style</b>	<p>Defines when to log messages on the Integration Log page. Values are:</p> <p><i>Log All:</i> An entry is entered into the integration log every time a message is received from the vendor.</p> <p><i>Never Log:</i> An entry is never made to the integration log.</p> <p><i>On Error:</i> An entry is made to the integration log only when an error occurs.</p>
<b>Node</b>	<p>Displays the node name that is associated with the vendor's transaction. These node names are dynamically created. Click a node link to access the Connectors page in PeopleTools Integration Broker.</p>
<b>Test</b>	<p>Click to access the Integration Test page, where you can test the integration setup for outgoing messages. The <b>Test</b> links do not apply to incoming transactions.</p>

## Pre-Employment Vendor Setup Page

Use the Pre-Employment Vendor Setup page (HRS\_PREEMPL\_VNDR) to define settings for pre-employment vendors.

Navigation:

Click the **Extended Setup** link on the Vendor Setup page.

This example illustrates the Pre-Employment Vendor Setup page.

The screenshot shows a web interface titled "Open Integration Framework" and "Pre-Employment Vendor Setup". Below the title is a section for "Preemployment Vendor" with the following details:

- Name:** HireRight, Inc
- Status:** Inactive
- Options:**
  - Display Adjudication
  - View Results on External Site

At the bottom of the form are three buttons: "OK", "Cancel", and "Apply".



<b>Field or Control</b>	<b>Description</b>
<b>Display Adjudication</b>	Select this check box to make the adjudication status visible to managers, recruiters, and recruiting administrators on the Manage Applicants - Pre-employment Check and Pre-employment Check - Pre-employment Check Details pages. If you deselect this check box, the system displays <i>Not Displayed</i> in the <b>Adjudication Status</b> fields on these pages.
<b>View Results on External Site</b>	Select this check box to make the <b>View Results</b> link on the Pre-employment Check - Pre-employment Check Details page visible to managers, recruiters, and recruiting administrators. Users click the <b>View Results</b> link to access a detailed page of the pre-employment inquiry on the vendor site.

## Integration Test Page

Use the Integration Test page (HRS\_VENDOR\_TEST) to test vendor integration.

Navigation:

Click the **Test** link for a transaction on the Vendor Setup page.

This example illustrates the Integration Test page.

The screenshot shows the 'Integration Test' page. At the top, there is a title 'Integration Test'. Below it is a table with two columns: 'Label' and 'Value'. The table contains one row with 'External Posting Id' in the 'Label' column and '6' in the 'Value' column. Below the table are two buttons: 'Run Test' and 'Cancel'.

<b>Field or Control</b>	<b>Description</b>
<b>Integration Test</b>	This grid lists the fields that require data in order for the test to be performed. Enter values for each field.
<b>Run Test</b>	Click to test the integration. The system displays the Integration Log page, where you can review the results of the test.

## Setting Up Autoscreening For Data Received from Vendors

To set up autoscreening for data received from vendors, use the AutoScreen Setup (HRS\_AUTOSCREEN) component.

### Page Used To Set Up Autoscreening For Data Received from Vendors

<i>Page Name</i>	<i>Definition Name</i>	<i>Usage</i>
<a href="#">AutoScreen Setup Page</a>	HRS_AUTOSCREEN	Identify an application class to automatically screen incoming applicant data. You reference autoscreening definitions from recruiting source definitions for vendors.

### Understanding Autoscreening

Autoscreening definitions represent one or more application classes for screening applicant data that is received from a third-party vendor.

You associate an autoscreening definition with a vendor when you set up the recruitment source definition for the vendor.

See [Setting Up Recruitment Sources](#).

### AutoScreen Setup Page

Use the AutoScreen Setup page (HRS\_AUTOSCREEN) to identify an application class for automatically screening incoming applicant data.

You reference autoscreening definitions from recruiting source definitions for vendors.

Navigation:

**Set Up HCM > Product Related > Recruiting > Recruitment Sources > AutoScreen > AutoScreen Setup**

This example illustrates the AutoScreen Setup page.

The screenshot shows the 'AutoScreen Setup' page. At the top, there is a header 'AutoScreen' and a sub-header 'AutoScreen Setup'. Below this is a form with three main fields:
 

- \*Name:** A text input field containing 'Email Verification'.
- \*Status:** A dropdown menu currently set to 'Active'.
- \*Description:** A larger text area containing 'Email Verification'.

 Below the form is a table titled 'Application Classes'. The table has a header row with 'Application Class Name' and a search icon. The first row of data contains 'Verify Email'. Navigation controls like 'Personalize', 'Find', 'First', '1 of 1', and 'Last' are visible above the table.

## Setting Up Data Mapping

To set up data mapping, use the Data Mapping Assignments (HRS\_DM\_MAP\_SETUP), Category Setup (HRS\_DM\_CAT\_SETUP), Data Mapping (HRS\_DM\_MAPPING), and Postal Map (HRS\_HRXML\_POSTAL) components.

### Pages Used to Set Up Data Mapping

<b>Page Name</b>	<b>Definition Name</b>	<b>Usage</b>
<u>Assigned Mapping Setup Page</u>	HRS_DM_MAP_SETUP	Create data mapping assignments.
<u>Category Setup Page</u>	HRS_DM_CAT_SETUP	Set up categories.
<u>Key List Page</u>	HRS_DM_CAT_KEYLIST	View key lists.
<u>Value List Page</u>	HRS_DM_CAT_VALLIST	View value lists.
<u>Unmapped Data Page</u>	HRS_DM_UNMAPPED	Map unmapped data.

<b>Page Name</b>	<b>Definition Name</b>	<b>Usage</b>
<u>Key Data Mapping Page</u>	HRS_DM_MAPPING_DICT	Map keys.
<u>Value Data Mapping Page</u>	HRS_DM_VALUE	Map values.
<u>Inbound Map Page</u>	HRS_HRXML_PSTL_IN	Map inbound postal information.
<u>Outbound Map Page</u>	HRS_HRXML_PSTL_OUT	Map outbound postal information.

## Understanding Data Mapping

Data mapping enables you to take information coming into your system, run it through an interpreter, and then have it presented to you in a format that fits your system. Data mapping is also used for outgoing messages in a similar fashion. The types of data mapping are:

- Assignments and categories.
- Postal.
- Predefined mappings.

### Assignments and Categories

Data mapping assignments define how the system translates the words or phrases coming into the system to the words or phrases used by your system. You can set up data mapping definitions based on site, recruitment source, vendor, or the default All mapping. You can also have just one data mapping definition to everything coming into your system.

Data mapping categories are data objects that are used by the assigned maps to define how data is mapped. PeopleSoft delivers 11 data mapping categories:

- Competencies.
- Honors and Awards.
- Language (accomplishment).
- Licenses and Certifications.
- Memberships.
- Degrees.
- Major.
- School.
- Country.
- State/Providence.

- Language (translate values).

These delivered data mapping categories were created to support Manage External Postings, Resume Management, and Background Screening. You can create a new data mapping category; however, some development work is necessary to define an appropriate application class.

For example, suppose a user creates a new entry in the School table for Stanford University with School ID = Stanford. This alone is not enough to map school data to or from the school ID Stanford. To begin mapping to or from this ID, the user must first run the synchronization process after creating the entry for Stanford University. To enable users to more efficiently process the synchronization for data mappings, PeopleSoft delivers a batch process that enables users to synchronize all data mapping categories at the same time. To initiate this process, navigate to **PeopleTools > Process Scheduler > System Process Requests** and create a new run control. Click the **Run** button, select a process server, select the Datamapping Sync (HRS\_DM\_SYNC) process, and click **OK**.

## Postal

When postal information needs to be exchanged between an XML document and a Recruiting Solutions database, decisions of how this exchange occurs must be determined. This determination is at the country level.

## Data Mapping Setup Steps

To set up data mapping:

1. Create data mapping assignments.
2. Synchronize data for each data mapping category.
3. (Optional) Build the search indexes for each category.
4. Establish postal mappings for each country's postal address.
5. Establish the necessary open integration framework vendors.

## Assigned Mapping Setup Page

Use the Assigned Mapping Setup page (HRS\_DM\_MAP\_SETUP) to create data mapping assignments.

Navigation:

**Set Up HCM > Product Related > Recruiting > Integration > Data Mapping Assignments > Assigned Mapping Setup**

This example illustrates the Assigned Mapping Setup page.

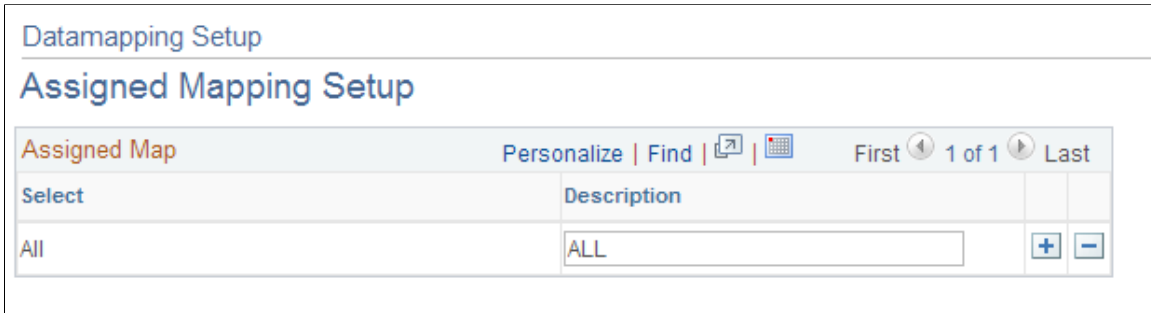

### Assigned Map

Use this group box to specify the vendors, sites, or recruitment sources that will not use the default data map. The description is used on the Unmapped Data, Key Data Mapping, and Value Data Mapping pages.

## Category Setup Page

Use the Category Setup page (HRS\_DM\_CAT\_SETUP) to set up categories.

Navigation:

**Set Up HCM > Product Related > Recruiting > Utilities > Data Mapping Categories > Category Setup**

This example illustrates the Category Setup page.

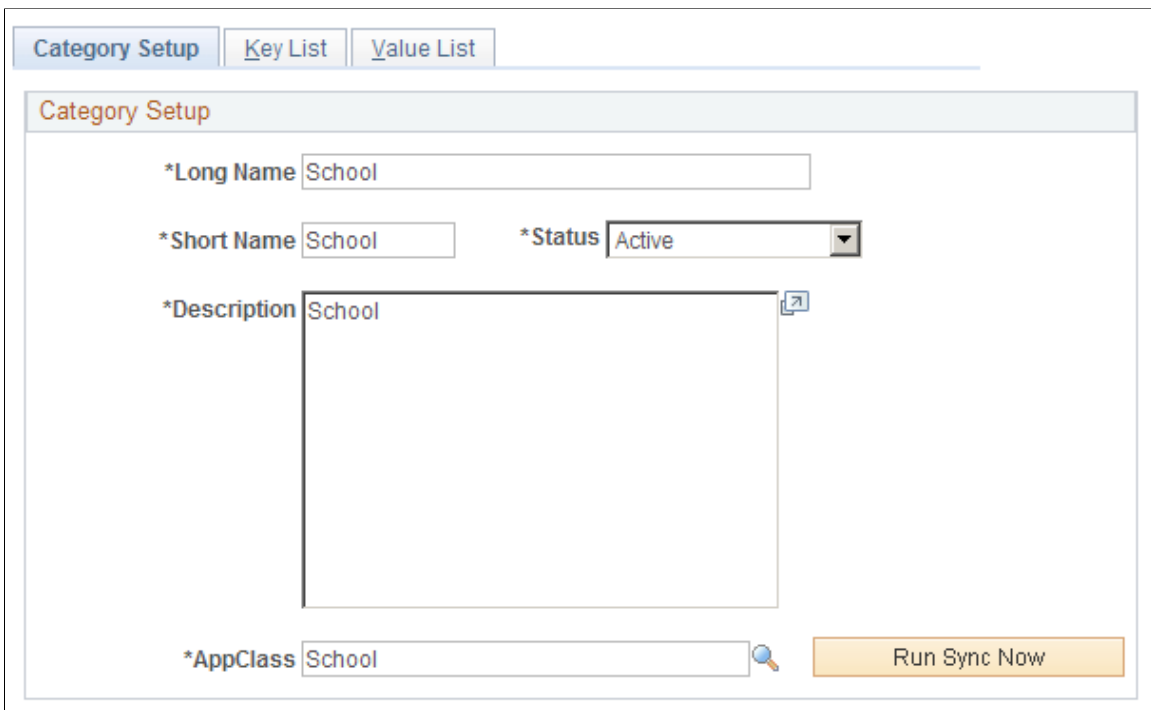

<b><i>Field or Control</i></b>	<b><i>Description</i></b>
<b>AppClass</b> (application class)	Select an application class category. These categories are defined on the Application Class Registry page.
<b>Run Sync Now</b> (run synchronization now)	Click to synchronize the data that is associated with the selected data mapping category with the data actually existing in the corresponding component. This process populates the Key List and Value List pages.

## Key List Page

Use the Key List page (HRS\_DM\_CAT\_KEYLIST) to view key lists.

Navigation:

**Set Up HCM > Product Related > Recruiting > Utilities > Data Mapping Categories > Key List**

This example illustrates the Key List page.

Category Setup
Key List
Value List

Key List

**Category** School

Keys
Personalize | Find | View 100 | | 
First 1-15 of 207 Last

SubCategory	Keys	Description ▲
	KPU13	Agra University
	KPU14	Aligarh Muslim University
	KPI16	All-India Institute of Medical
	KPU01	Andhra University College of E
	KPU15	Andhra University, College of
	KPU02	Anna University
	KPU03	Annamalai University
	KUS014	Arizona State
	F00014	Arizona State
	KPC15	Armed Forces Medical College,
	KPC16	BMS College of Engineering
	KPU16	Banaras Hindu University
	KPU17	Bangalore University
	KPC17	Bengal Engineering College
	KUS001	Berkeley, University of CA

<b>Field or Control</b>	<b>Description</b>
<b>Subcategory</b>	Serves as a secondary key for the data mapping functionality. Not all categories use the subcategory secondary key. Subcategories themselves must also be data mappings.
<b>Keys</b>	Displays the primary key for the category. These keys are determined by the data in the associated data mapping category tables. Click the key link to access the Key Data Mapping page. This page displays all the values that are mapped to the given key.



## Value List Page

Use the Value List page (HRS\_DM\_CAT\_VALLIST) to view value lists.

Navigation:

**Set Up HCM > Product Related > Recruiting > Utilities > Data Mapping Categories > Value List**

This example illustrates the Value List page.

Value List		
Category School		
Values	Personalize   Find   View 100   [Print]   [Calendar]	First 1-15 of 594 Last
SubCategory	Keys	Language
	<a href="#">University of Georgia</a>	English
	<a href="#">KF001</a>	English
	<a href="#">Paris Business School</a>	English
	<a href="#">FRA_KF001</a>	English
	<a href="#">KF002</a>	English
	<a href="#">La Sorbonne University</a>	English
	<a href="#">FRA_KF002</a>	English
	<a href="#">KF003</a>	English
	<a href="#">Ecole Polytechnique</a>	English
	<a href="#">FRA_KF003</a>	English
	<a href="#">KGS001</a>	English
	<a href="#">Oxford University</a>	English
	<a href="#">GBR_KGS001</a>	English
	<a href="#">KGS002</a>	English
	<a href="#">University of Cambridge</a>	English

The Value List page lists all the values that are being mapped to a category key. Click a link in the **Keys** column to access the Value Data Mapping page.

## Unmapped Data Page

Use the Unmapped Data page (HRS\_DM\_UNMAPPED) to map unmapped data.

Navigation:

**Set Up HCM > Product Related > Recruiting > Integration > Data Mapping > Unmapped Data**

This example illustrates the Unmapped Data page.

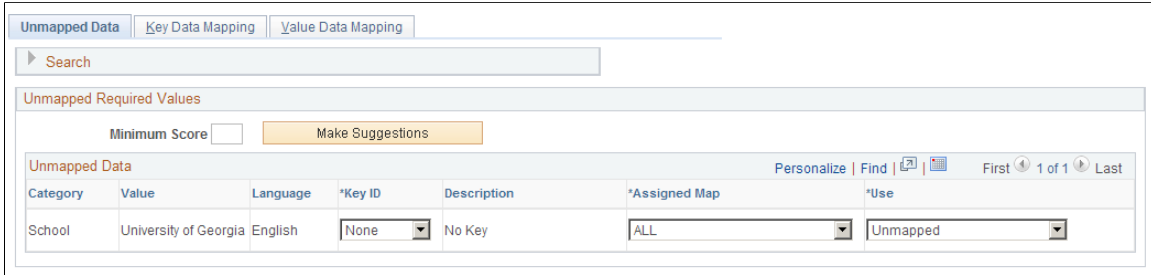

<i><b>Field or Control</b></i>	<i><b>Description</b></i>
<b>Minimum Score</b>	Identifies a threshold for the Make Suggestions search. Only results that are greater than or equal to the minimum score appear in the <b>Key ID</b> field. The score of every suggestion found appears to the right of each key ID item in parentheses.
<b>Make Suggestions</b>	Click to run a search that provides a suggested mapping based on the minimum score that you entered.

## Key Data Mapping Page

Use the Key Data Mapping page (HRS\_DM\_MAPPING\_DICT) to map keys.

Navigation:

**Set Up HCM > Product Related > Recruiting > Integration > Data Mapping > Key Data Mapping**

This example illustrates the Key Data Mapping page.

The screenshot shows the 'Key Data Mapping' tab in a software interface. At the top, there are three tabs: 'Unmapped Data', 'Key Data Mapping', and 'Value Data Mapping'. Below the tabs is a search section with a dropdown arrow and the word 'Search'. This section contains several input fields: 'Key' (text box), 'Value' (text box), 'Assigned Map' (dropdown menu), 'Category' (dropdown menu with 'School' selected), and 'Language' (dropdown menu). A 'Search' button is located below these fields.

Below the search section is the 'Key Results' section. It has a header with 'Key Results' on the left and navigation controls 'Find | View 100 | First 1 of 207 Last' on the right. The main content area shows details for a key: 'Key KF001', 'Description Paris Business School', and 'Category School'. Below this, there is a 'SubCategory' label and a 'Values' table. The 'Values' table has a header with 'Personalize | Find | [Print] [Grid] | First 1-3 of 3 Last'. The table has five columns: 'Value', 'Assigned Map', 'Language Code', '\*Use', and 'Go'. There are three rows of data in the table, each with a 'Go' button to its right. Below the table is an 'Insert' button.

Value	Assigned Map	Language Code	*Use	Go
KF001	ALL	English	In Only	Go
Paris Business School	ALL	English	Both	Go
FRA_KF001	ALL	English	In Only	Go

This page displays a complete list of all the values that are mapped to a given key.

### Values

This group box enables you to add other values to the key. The values must be chosen from the unmapped data values.

<b>Field or Control</b>	<b>Description</b>
<b>Value</b>	Select the values that are associated with the key.
<b>Assigned Map</b>	Select the data mapping assignment that the key is associated with.
<b>Language Code</b>	Select the language that the value is assigned to

<b>Field or Control</b>	<b>Description</b>
<b>Use</b>	Select to use this data mapping for incoming data, outgoing data, or both.
<b>Insert</b>	Click to add a row to the group box.

## Value Data Mapping Page

Use the Value Data Mapping page (HRS\_DM\_VALUE) to map values.

Navigation:

**Set Up HCM > Product Related > Recruiting > Integration > Data Mapping > Value Data Mapping**

This example illustrates the Value Data Mapping page.

The screenshot shows the 'Value Data Mapping' page with the following elements:

- Navigation tabs: **Unmapped Data**, **Key Data Mapping**, and **Value Data Mapping** (selected).
- Search** section:
  - Key:
  - Value:
  - Assigned Map:
  - Category:
  - Language:
  - Search** button
- Value Results** section:
  - Find | View 100 | First 1 of 594 Last
  - Value: University of Georgia
  - Category: School
  - SubCategory:
  - Language: English
  - Insert** button

Displays all the keys that are mapped to the given value.

## Keys

This group box displays all the keys that are mapped to the value and enables you to map more keys to the value. The keys that you add come from the unmapped data values.

<i>Field or Control</i>	<i>Description</i>
<b>Key</b>	Select the key ID of the data mapping.
<b>Assigned Mapping ID</b>	Select the data mapping assignment that the key is associated with.
<b>Use</b>	Select to use this data mapping for incoming data, outgoing data, or both.

## Inbound Map Page

Use the Inbound Map page (HRS\_HRXML\_PSTL\_IN) to map inbound postal information.

Navigation:

**Set Up HCM > Product Related > Recruiting > Integration > Postal Map > Inbound Map**

This example illustrates the Inbound Map page.

The screenshot shows the 'Inbound Map' page for 'Country AUS Australia'. It features a table titled 'Inbound Postal Mapping' with columns: Field Name, Edit Label Override, Include in Display?, Line Number, Position Number, and HR XML Postal. The table contains six rows of mappings. Below the table is a 'Map Default' button.

Field Name	Edit Label Override	Include in Display?	Line Number	Position Number	HR XML Postal
ADDRESS1	<input checked="" type="checkbox"/>	<input checked="" type="checkbox"/>	1	1	AddressLine[1]
ADDRESS2	<input checked="" type="checkbox"/>	<input checked="" type="checkbox"/>	2	1	AddressLine[2]
CITY	<input type="checkbox"/>	<input checked="" type="checkbox"/>	3	1	Municipality
COUNTRY	<input type="checkbox"/>	<input type="checkbox"/>			CountryCode
POSTAL	Postcode	<input checked="" type="checkbox"/>	3	3	Postal Code
STATE		<input checked="" type="checkbox"/>	3	2	Region[1]

This page displays the field names that are associated with the Country table.

<b>Field or Control</b>	<b>Description</b>
<b>HR XML Postal</b>	Select the XML element where you want the corresponding PeopleSoft field to be written for incoming messages.
<b>Map Default</b>	Click to have the system make an initial guess at what the mapping from the XML should be.

## Outbound Map Page

Use the Outbound Map page (HRS\_HRXML\_PSTL\_OUT) to map outbound postal information.

Navigation:

**Set Up HCM > Product Related > Recruiting > Integration > Postal Map > Outbound Map**

This example illustrates the Outbound Map page.

The screenshot shows the 'Outbound Map' page for Australia. At the top, there are tabs for 'Inbound Map' and 'Outbound Map'. Below the tabs, the country is set to 'AUS' (Australia). The main section is titled 'Outbound Postal Mappings' and includes a table with the following data:

Field Name	Edit Label Override	Include in Display?	Line Number	Position Number	HR XML Postal	Sequence
ADDRESS1		<input checked="" type="checkbox"/>	1	1	AddressLine[1]	1
ADDRESS2		<input checked="" type="checkbox"/>	2	1	AddressLine[2]	1
CITY		<input checked="" type="checkbox"/>	3	1	Municipality	
COUNTRY		<input type="checkbox"/>			CountryCode	
POSTAL	Postcode	<input checked="" type="checkbox"/>	3	3	Postal Code	
STATE		<input checked="" type="checkbox"/>	3	2	Region[1]	

Below the table is a 'Map Default' button.

This page displays the address field names that are associated with the Country table.

<b>Field or Control</b>	<b>Description</b>
<b>HR XML Postal</b>	Select the XML element where you want the corresponding PeopleSoft field to be written for outgoing messages.
<b>Map Default</b>	Click to have the system make an initial guess at what the mapping from the XML should be.
<b>Sequence</b>	When multiple data elements from the PeopleSoft address table are mapped to a single element in the XML document, the sequence number determines the order in which the PeopleSoft fields are mapped.

## Setting Up Resume Email Accounts

To set up resume email accounts, use the (HRS\_EMAIL\_SETUP) component.

### Pages Used to Define Resume Email Accounts

<i>Page Name</i>	<i>Definition Name</i>	<i>Usage</i>
<a href="#">Email Setup Page</a>	HRS_EMAIL_SETUP	Set up resume email accounts where organizations or individuals will send resumes.
<a href="#">Email List Page</a>	HRS_EMAIL_LIST	View a list of emails that have been retrieved from the email account.
<a href="#">View Email Message/Attachments Page</a>	HRS_EMAIL_VIEW	View email attachments and select resumes.

### Understanding Resume Email Accounts

If the organization requires applicants or staffing suppliers to submit resumes using email, you must set up one or more email accounts to receive those emails. In most cases, the applicants that send resumes to an email account are external applicants.

The system can process resumes that applicants send using email as attachments and resumes that are included in the body of the email message. If no attachment is found on the email, the system assumes that the resume is in the body of the email message. The system enables recruitment administrators to select which part of the email is the resume that will be passed to the resume extractor on the View Email Message/Attachments page.

The system does not support multiple resumes per email. If the system receives an email with multiple attachments, it processes the email as a single applicant even if it contains resumes from multiple applicants. This enables an applicant to send individual cover letter, resume, and reference attachments.

### Setting Up Resume Email Accounts

To receive incoming resumes by email:

1. Set up an email account, user name, password, and email server to receive resumes.
2. Set up a resume extractor vendor.

See [Setting Up Recruiting Vendors](#).

3. Set up a recruitment source of type Vendor to associate with the incoming emails.

See [Setting Up Recruitment Sources](#).

4. Set up an email node on the Connectors page.

PeopleSoft delivers the following standard email node: MCF\_GETMAIL.

- a. You must select a valid value in the **Value** column for the MCF\_AttRoot property.

This value specifies where email attachments are temporarily stored. The MCF\_AttRoot value is supplied to the **Path** field on the Resume Email page by default when you create a new email account.

- b. Select *True* in the **Value** column for the MCF\_Force\_Download\_Attachments property.

5. Create an email account on the Resume Email page.

Associate the email address, user name, password, email server, resume extractor vendor, recruitment source, and email node with the email account.

6. (Optional) Set up data mappings to support applicants from the recruitment source.

## Processing Emails

To process emails that you receive in the email account:

1. Run the Email Checking Process Application Engine process (HRS\_HROI\_EML).

When you run this process, the system checks the email account for emails, deletes the emails from the email account in box, and writes the emails to the database. Because the system deletes all emails from the email account in box, you should not use a personal email address when you create the email account. The emails that the system writes to the database appear on the Email List page. The system stores all content from the email in the database, including the HTML, text, subject line, email address, and attachments.

2. Run the Process Awaiting Email Application Engine process (HRS\_PRCES\_EML).

This process extracts data from the resumes for all email messages that are written to the database. The system processes all resumes that appear on the Email List page.

The recruitment source that you assign to the email account determines how the system handles incoming resumes. For example, the system uses the resume extractor, country, and language that you associate with the recruitment source to extract data from the resumes, and the system uses the screening setup parameters that you specify for the recruitment source to determine which status to assign to each resume and what notification to send to each applicant, if any, based on the assigned status.

Schedule the Email Checking Process and Process Awaiting Email processes to run by using the Process Scheduler Request page in PeopleTools. You can also manually run the Email Checking Process by clicking the **Check Email** button on the Email List page.

See *PeopleTools: Process Scheduler*

## Email Setup Page

Use the Email Setup page (HRS\_EMAIL\_SETUP) to set up resume email accounts where organizations or individuals will send resumes.



Navigation:

**Set Up HCM > Product Related > Recruiting > Integration > Resume Email > Email Setup**

This example illustrates the Email Setup page.

The screenshot shows the 'Email Setup' page with the following fields and values:

- \*Status:** Active (dropdown menu)
- \*Email:** resume\_890A@rt.peoplesoft.com
- \*User:** resume\_890A
- \*Password:** [masked with dots]
- \*Server:** tl-mail01
- \*Node:** MCF\_GETMAIL (with search icon)
- \*Path:** c:\temp
- \*Source:** Bestway Job Board (dropdown menu)

At the bottom of the form is a 'Test Settings' button.

<b>Field or Control</b>	<b>Description</b>
<b>Status</b>	Select a status: <i>Active</i> or <i>Inactive</i> . If you select <i>Inactive</i> , the system does not run the Email Checking Process. However, the system does run the Process Awaiting Emails process for all resumes in the Awaiting Resolution state.
<b>Email, User, and Password</b>	Enter the email address where you want to receive applicant emails, and the user ID and password for the email address.
<b>Server</b>	Enter the email server where you set up the email address.
<b>Node</b>	Select the node that you set up to receive emails. PeopleSoft delivers the following standard email node: MCF_GETMAIL.
<b>Path</b>	Enter the path where the email node stores email attachments. By default, the value that you specify for the MCF_AttRoot property on the Connectors page appears here.

<b>Field or Control</b>	<b>Description</b>
<b>Source</b>	Select the recruitment source with which you want to associate the incoming emails. Only recruitment sources with a source type of Vendor appear in the prompt. This is not a required field; however, you should populate this field with a source to properly manage incoming resumes. Define recruitment sources by using the Source Setup (HRS_SOURCE_SETUP) component.
<b>Test Setting</b>	Click to test the setup. In this process, the system obtains an email count. If the system can get a count, even if the count is zero, the setup is a success. A success or fail message appears depending on whether the setup is a success or failure.

## Email List Page

Use the Email List page (HRS\_EMAIL\_LIST) to view a list of emails that have been retrieved from the email account.

Navigation:

**Set Up HCM > Product Related > Recruiting > Integration > Resume Email > Email List**

This example illustrates the Email List page.

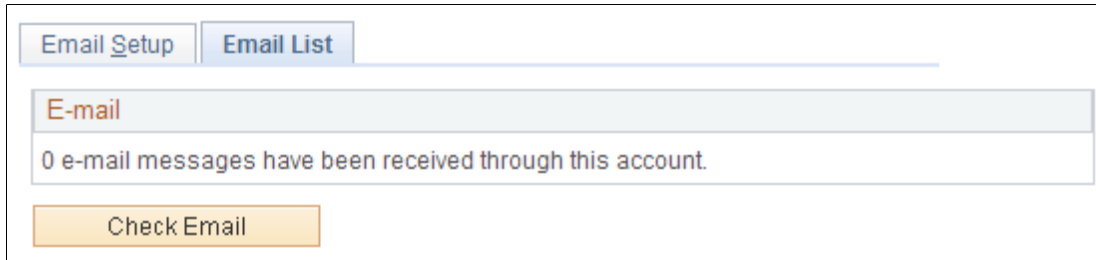

### Email

Use this group box to view a list of emails that have been retrieved from this email address.

<b><i>Field or Control</i></b>	<b><i>Description</i></b>
<b>Resume Attachment</b>	Displays the filename of the attachment that the system has selected to use as the applicant's resume in the resume extraction process. The system always selects the last attachment to use as the applicant's resume. If no attachments are in the email message, the system uses the text in the email message for the applicant's resume. If you determine that the attachment that the system selects is not the applicant's resume, use the View Email Message/Attachments page to select the appropriate attachment. Click an attachment link to view the file.
<b>Email From</b>	Displays the email address of the sender.
<b>Subject</b>	Displays the text that appears as the subject for the email. Click to access the View Email Message/Attachments page, where you can view the email message text and email attachments, and select the attachment that you want the system to use as the applicant's resume in the resume extraction process.
<b>Date From</b>	Displays the date and time that the email was received in the email account.

### **Additional Page Element**

<b><i>Field or Control</i></b>	<b><i>Description</i></b>
<b>Check Email</b>	Click to run the Email Checking Process.

## **View Email Message/Attachments Page**

Use the View Email Message/Attachments page (HRS\_EMAIL\_VIEW) to view email attachments and select resumes.

Navigation:

Click the subject link for an email that is listed on the Email List page.

Use this page to view the email message text and email attachments, and select the attachment that you want the system to use as the applicant's resume in the resume extraction process.

<i>Field or Control</i>	<i>Description</i>
<b>Message</b>	Displays the exact message text from the email message.

## Attachments

<i>Field or Control</i>	<i>Description</i>
<b>Attachments</b>	Displays all of the attachments that the system detects in the email message. Click an attachment link to view the file. The Plain Text attachments contain the actual message text from the email message.
<b>Set Resume</b>	Click to set the associated attachment as the applicant's resume. This button is inactive for the attachment that the system selects as the resume.

---

## Reviewing the Integration Transaction Log

This topic discusses how to review the integration transaction log.

### Pages Used to Review the Integration Transaction Log

<i>Page Name</i>	<i>Definition Name</i>	<i>Usage</i>
<a href="#">Integration Log Page</a>	HRS_HROI_LOG	Review the integration transaction log.
<a href="#">Integration Log Outgoing Msg Page</a> (integration log outgoing message page)	HRS_HROI_LOG_O_XML	Review detailed information about outgoing messages.

### Integration Log Page

Use the Integration Log page (HRS\_HROI\_LOG) to review the integration transaction log.

Navigation:

**Set Up HCM > Product Related > Recruiting > Integration > Recruiting Integration Log > Integration Log**

This example illustrates the Integration Log page.

Open Integration Framework

### Integration Log

Search Integration Log

Status

Vendor

Transaction ID

Last Updated From  To

Search

---

Search Results Personalize | Find | View All | 1-4 of 4 | First 1-4 of 4 Last

Transaction	Transaction Type	Vendor	Last Updated	Status
<a href="#">ResumeExtract</a>	Outbound Synchronous	Resume Mirror Inc	01/30/2013 12:03PM	Succeeded
<a href="#">ResumeExtract</a>	Outbound Synchronous	Resume Mirror Inc	01/31/2013 5:11AM	Succeeded
<a href="#">ResumeExtract</a>	Outbound Synchronous	Resume Mirror Inc	01/31/2013 5:12AM	Succeeded
<a href="#">ResumeExtract</a>	Outbound Synchronous	Resume Mirror Inc	01/31/2013 8:36PM	Succeeded

### Search Results

This group box displays the messages received from vendors that match the search criteria that you enter in the **Search Integration Log** group box.

### Integration Log Outgoing Msg Page

Use the Integration Log Outgoing Msg (integration log outgoing message) page (HRS\_HROI\_LOG\_O\_XML) to review detailed information about outgoing messages.

Navigation:

**Click a transaction link on the Integration Log page.**

This example illustrates the Integration Log Outgoing Msg page .

### Integration Log Outgoing Msg

[Open Integration Framework](#)

## Outgoing Message Details

**Request**

```

<?xml version="1.0"?>
<SOAP-ENV:Envelope xmlns:SOAP-ENC="http://schemas.xmlsoap.org/soap/encoding/" xmlns:SOAP-
ENV="http://schemas.xmlsoap.org/soap/envelope/" xmlns:m="http://peoplesoft.com/HCM/Schema"
xmlns:xsd="http://www.w3.org/2001/XMLSchema" xmlns:xsi="http://www.w3.org/2001/XMLSchema-instance">
  <SOAP-ENV:Body>
    <m:Input>
      <Values>
        <Value>
          <Name>login</Name>
          <Value>peoplesoftdev</Value>
          ...
      </Values>
    </m:Input>
  </SOAP-ENV:Body>
</SOAP-ENV:Envelope>
```

**Vendor Request**

```

<?xml version="1.0"?>
<soap:Envelope xmlns:soap="http://schemas.xmlsoap.org/soap/envelope/" xmlns:xsd="http://www.w3.org/2001/XMLSchema"
xmlns:xsi="http://www.w3.org/2001/XMLSchema-instance">
  <soap:Body>
    <ProcessResumeStream xmlns="http://resumemirror.com">
      <resumestream>DQpNaWxseSBXaWxseQ0KMTMyMTAgR3Jvd2luZyBTdHJIZXQNCkxhcncNvbiBHQSzWgMzAzMjgN
CIRlbgVvaG9uZTogMzM4LTg4OC01NTU1DQpNaWxseVdpcGx5QG1pbGx5LmNvbQ0KDQoNck9i
amVjdGl2ZQ0KVg8gc2VjdXIIEGgbWFuYWdlbWVuudCBwb3NpdGlvb0aGF0IHdpbGwgchJv
dmIkZSBtZSB0aGUg3Bwb3J0dW5pdHkgdG8gDQpjb250cmliidXRlIGFuZCBwYXJ0aWVucGF0
ZSBpb0aGUgZ3Jvd3R0IG9mIHRoZSBjb21wYW55LiBTdXBwb3J0aW5naA0Kc3RyZW5ndGhz
...
    </resumestream>
  </ProcessResumeStream>
</soap:Body>
</soap:Envelope>
```

**Vendor Response**

```

<?xml version="1.0"?>
<soap:Envelope xmlns:soap="http://schemas.xmlsoap.org/soap/envelope/" xmlns:xsd="http://www.w3.org/2001/XMLSchema"
xmlns:xsi="http://www.w3.org/2001/XMLSchema-instance">
  <soap:Body>
    ...
  </soap:Body>
</soap:Envelope>
```

This page includes the following fields that display detailed information about integration messages:

- Request
- Vendor Request
- Vendor Response
- Response
- Error

# Setting Up Recruitment Sources

---

## Understanding Recruitment Sources

This topic provides an overview of recruitment sources and lists the prerequisites for setting up recruitment sources.

### Purpose of Recruitment Sources

Recruitment sources represent avenues for finding applicants for your job openings. The system uses recruitment sources in two ways:

- *Posting Destinations* are places where you publish information about your job openings.

When you create job postings, you specify the destinations for each posting. In the field where you identify your posting destination, the list of available options comes from the recruitment source table.

See [Posting Information Page](#).

- *Referral Sources* are places where applicants learn about job openings.

Applications include a section where applicants provide information about where they learned about the job opening. This section is always visible when a recruiter views the application using Talent Acquisition Manager. You use resume templates to control whether this section appears in the online application form that an applicant uses in Candidate Gateway. In both locations, in the field where you identify your posting destination, the list of available options comes from the recruitment source table.

See [Entering Application Details](#).

### The Four Types of Recruitment Sources

PeopleSoft delivers four types of recruitment sources. All source types can include descriptions and contact information, but each type also has its own type-specific setup. The following table describes the four source types:

<b>Source Type</b>	<b>Usage</b>	<b>Description</b>	<b>Type-Specific Setup</b>
Company	Posting destination	Your organization's own Candidate Gateway job sites, as defined on the Site Definition page.	Specify one or more Candidate Gateway sites where the job opening is posted when the source is used as a posting destination.  See "Setting Up Sites" (PeopleSoft Candidate Gateway).

<b>Source Type</b>	<b>Usage</b>	<b>Description</b>	<b>Type-Specific Setup</b>
Vendor	Posting destination	<p>Third-party vendors with whom you integrate using the open integration framework.</p> <p>Examples might include job boards, recruiting agencies, and service procurement providers.</p>	<p>Specify various integration options, including the vendor definition, autoscreening options, resume extraction settings, and notifications.</p> <p>See <a href="#">Setting Up Recruiting Vendors</a>.</p>
Marketing	<ul style="list-style-type: none"> <li>• Posting destination</li> <li>• Referral source</li> </ul>	<p>Places where you advertise job openings.</p> <p>Examples might include internet or email advertisements, print advertisements, and job fairs.</p> <p>The system enables you to track the use of marketing sources either as posting destinations or as referral sources. This data is informational only. There is no integration with other systems, and there are no delivered reports for this data.</p>	<p>Identify which Candidate Gateway sites permit applicants to select the marketing source in the referrals section of the online job application.</p> <p>Optionally define subsources. For example, if you have a source for magazines, you could list specific publications as subsources.</p>
Employee	Referral source	<p>Employee referrals.</p> <p>On the pages where recruiters and applicants identify referral sources, selecting an employee referral source causes the system to display fields for identifying the employee who made the referral.</p> <p>The system uses this data for processing awards under employee referral programs that you administer within the recruiting system.</p>	<p>Identify which Candidate Gateway sites permit applicants to select the employee source in the referrals section of the online job application.</p>



This diagram illustrates the uses of the four recruitment source types. In the diagram, three source types (Company, Vendor, and Marketing) can be used as posting destinations, while two source types (Marketing and Employee) can be used as referral sources:

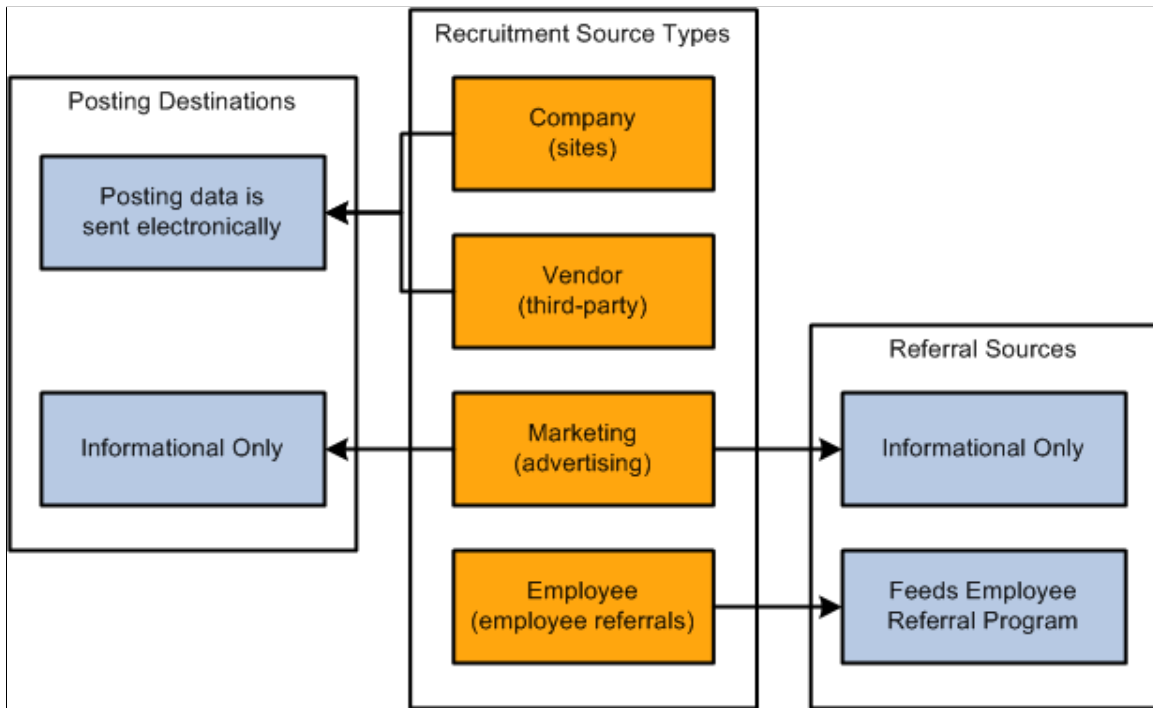

## Prerequisites

Before you set up recruitment sources, set up your Candidate Gateway sites.

See “Setting Up Sites” (PeopleSoft Candidate Gateway).

Additionally, for vendor recruitment sources, also set up:

1. Vendor definitions.

See [Setting Up Recruiting Vendors](#).

2. Autoscreening definitions.

See [Setting Up Autoscreening For Data Received from Vendors](#).

---

## Setting Up Recruiting Contacts

To set up recruitment contacts, use the Recruitment Contacts (HRS\_CONTACT) component.

## Page Used to Set Up Recruiting Contacts

<i>Page Name</i>	<i>Definition Name</i>	<i>Usage</i>
<u>Contact Setup Page</u>	HRS_CONTACT	Define contact information (name, address, phone, and email) for recruiting sources. You reference recruiting contacts from recruiting source definitions.

## Understanding Recruiting Contacts

Recruiting contacts are people who are associated with specific recruiting sources such as a third-party staffing agency. When you set up a recruiting contact, you specify name, address, phone, and email information. You do not prompt against your HR employee records to identify recruiting contacts, as recruiting contacts are typically third party representatives.

Recruiting contacts are not members of the job opening hiring team, but you can associate recruiting contact with jobs using the **Recruitment Contact** field in the Opening Information section of the Job Opening page.

When you associate a recruiting contact with a *Vendor* type recruitment source, you can also specify whether the contact is acting as the proxy for applicants that the vendor supplied. If you activate the proxy option, then pages that show applicant contact information also show the contact information for the proxy. When you send correspondence to an applicant who uses a proxy, the system sends the correspondence to the proxy, not the applicant.

## Contact Setup Page

Use the Contact Setup page (HRS\_CONTACT) to define contact information (name, address, phone, and email) for recruiting sources.

You reference recruiting contacts from recruiting source definitions.

Navigation:

**Set Up HCM > Recruiting > Recruitment Sources > Recruitment Contacts > Contact Setup**

This example illustrates the Contact Setup page.

**Contacts**

**Contact Setup**

**Contact**

Code  \*Contact Type

Description

Short Description

Name

**Address**

Country

Address 1

Address 2

Address 3

City

State

Postal

County

**Telephone**

**Phone Details**

Phone Type	Country Code	Telephone		
<input style="border: none; background-color: #f0f0f0; padding: 2px 5px;" type="text" value="Business"/>	<input type="text"/>	<input type="text" value="213/343-2700"/>	+	-

**Email Address**

Email Addresses

## Contact

<b>Field or Control</b>	<b>Description</b>
<b>Contact Type</b>	Select the type of contact. Values are <i>General</i> , <i>Office</i> , and <i>Source</i> .

## Address

Enter the address for this contact.

Address fields (with lookup) appear as drop-down by default. However, this configuration can be changed from the framework using the Country Format setup. For more information, see “Entry and Validation Page” (Application Fundamentals)

---

**Note:** The system displays warning messages when any address fields are left blank. If it is not a mandatory field, the user can ignore the message and save the data.

---

## Telephone

Enter the telephone numbers for this contact.

## Email Addresses

Enter the email addresses for this contact.

---

# Setting Up Recruitment Sources

To set up recruitment sources, use the AutoScreen Setup (HRS\_AUTOSCREEN) and Recruitment Sources (HRS\_SOURCE\_SETUP) components.

## Pages Used to Set Up Recruitment Sources

<i>Page Name</i>	<i>Definition Name</i>	<i>Usage</i>
<u>Recruitment Sources - Source Setup Page</u>	HRS_SOURCE_BASIC	Select a recruitment source type and define basic information for a source.
<u>Recruitment Sources - Company Page</u>	HRS_SOURCE_CMPNY	Define sites for a company recruitment source.
<u>Recruitment Sources - Marketing Page</u>	HRS_SOURCE_MKT	Define sites and subsources for marketing recruitment sources.
<u>Recruitment Sources - Employee Page</u>	HRS_SOURCE_EMP	Define sites for employee recruitment sources.
<u>Recruitment Sources - Vendor Page</u>	HRS_SOURCE_VNDR	Identify a third-party vendor and enter additional processing rules for vendor recruitment sources.
<u>Recruitment Sources - Contacts Page</u>	HRS_SOURCE_CONTACT	Define contacts for all types of recruitment sources.

## Recruitment Sources - Source Setup Page

Use the Recruitment Sources - Source Setup page (HRS\_SOURCE\_BASIC) to select a recruitment source type and define basic information for a source.

Navigation:

**Set Up HCM > Product Related > Recruiting > Recruitment Sources > Source Setup**

This example illustrates the Recruitment Sources - Source Setup page.

<b>Field or Control</b>	<b>Description</b>
<b>Source Name</b>	Enter a source name. This field is enterable only when you first add the source.
<b>Source Type</b>	<p>Select a source type: <i>Company</i>, <i>Employee</i>, <i>Marketing</i>, or <i>Vendor</i>. This field is enterable only when you first add the source.</p> <p>The source type that you select here controls the pages that appear in this component. When you select a source type, the <i>Company</i>, <i>Marketing</i>, <i>Employee</i>, or <i>Vendor</i> page appears, depending on the source type that you select.</p>
<b>Effective Date</b>	Enter an effective date. The only page in the system where you can select a source prior to the effective date is the <i>Job Opening - Posting Information</i> page. On this page, you can select a future-dated source as long as the effective date of that source is within the posting dates for that posting.
<b>Status</b>	Select <i>Active</i> or <i>Inactive</i> . Inactive sources do not appear in system prompts.

<b>Field or Control</b>	<b>Description</b>
<p><b>Use as Job Posting Destination</b></p>	<p>This check box appears only if the <b>Source Type</b> is <i>Marketing</i>. Select this check box to make a marketing source available as a posting destination.</p> <p>When you use the <u>Posting Information Page</u> to create a job posting, the drop-down list of posting destinations always includes all Company and Vendor recruiting sources, but Marketing sources appear only when they are explicitly configured for use as a posting destination.</p> <p>Unlike Company and Vendor destinations, marketing destinations cannot receive electronic posting information. Therefore, posting jobs to marketing sources is informational only, for tracking where you've published postings. If your organization uses this mechanism to track where you market your postings, select the <b>Use as Job Posting Destination</b> check box for the appropriate Marketing recruiting courses. Otherwise, leave the check box deselected so that users do not see unnecessary options in the drop-down list of posting destinations.</p>
<p><b>Description</b></p>	<p>Enter a description. This field is used only for informational purposes.</p>

## Recruitment Sources - Company Page

Use the Recruitment Sources - Company page (HRS\_SOURCE\_CMPNY) to define sites for a company recruitment source.

---

**Note:** This page appears only for recruitment sources with the source type *Company*.

---

Navigation:

**Set Up HCM > Product Related > Recruiting > Recruitment Sources > Company**

This example illustrates the Recruitment Sources - Company page.

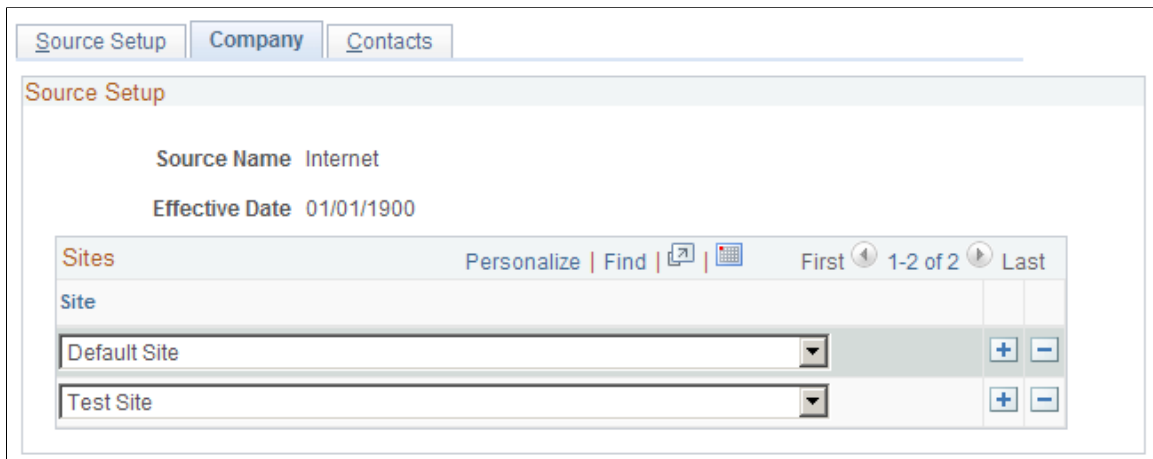

<b>Field or Control</b>	<b>Description</b>
<b>Site</b>	<p>Select one or more sites. When a recruiter or hiring manager creates a job opening and selects to post the job opening to this source, the system posts the job opening to all of the sites that you select here.</p> <p>For example, if your organization has separate careers sites for separate business units, then you can create three Company recruitment sources, each associated with the appropriate site. If your organization additionally has a consolidated careers site, you can add that site to each of the business unit-specific recruitment sources so that jobs posted to a specific business unit's site will always be posted to the consolidated site as well.</p>

## Recruitment Sources - Marketing Page

Use the Recruitment Sources - Marketing page (HRS\_SOURCE\_MKT) to define sites and subsources for marketing recruitment sources.

---

**Note:** This page appears only for recruitment sources with the source type *Marketing*.

---

Navigation:

**Set Up HCM > Product Related > Recruiting > Recruitment Sources > Marketing**

This example illustrates the Recruitment Sources - Marketing page.

The screenshot shows the 'Marketing' tab of the 'Recruitment Sources' page. It is divided into two main sections: 'Source Setup' and 'Subsources'.

**Source Setup:** Shows 'Source Name' as 'Magazines' and 'Effective Date' as '01/01/1900'. Below this is a table titled 'Access by Site Id' with columns for 'Site', '+', and '-'. The table lists four sites: 'GBI Corporate - Internal Site', 'GBI Corporate - External Site', 'GBI Media - Internal Site', and 'GBI Media - External Site'.

**Subsources:** Shows a table with columns for 'Subsource Description' and '\*Status'. The table lists four subsources: 'The New Yorker', 'The Economist', 'The Wall Street Journal', and 'Other', all with a status of 'Active'.

### Access by Site ID

Use this grid to specify which Candidate Gateway sites list this recruitment source as a valid referral source. For example, if you are defining a recruitment source for your internal employee newsletter, you would associate that source with the internal sites used by the employees who receive that newsletter.

Once a source is associated with a site, applicants who apply for jobs on that site can select that source in the **How did you find out about us?** field in the online application form (if the resume template includes the Referrals section).

### Subsources

Use this grid to define subsources for marketing sources. When a user selects a source on the online application pages in Candidate Gateway (or on the Load Resume - Prepare Load Parameters page), the user also can select a subsource from a list of values that you define here. Only active subsources appear as valid options.

## Recruitment Sources - Employee Page

Use the Recruitment Sources - Employee page (HRS\_SOURCE\_EMP) to define sites for employee recruitment sources.



---

**Note:** This page appears only for recruitment sources with the source type *Employee*.

---

Navigation:

**Set Up HCM > Product Related > Recruiting > Recruitment Sources > Employee**

This example illustrates the Recruitment Sources - Employee page.

Site	Personalize	Find	First	1-3 of 3	Last
Default Site					
GBI Corporate - External Site					
GBI Media - External Site					

### Access by Site ID

Use this grid to specify which Candidate Gateway sites list this recruitment source as a valid referral source.

Once a source is associated with a site, applicants who apply for jobs on that site can select that source in the **How did you find out about us?** field in the online application form (if the resume template includes the Referrals section).

## Recruitment Sources - Vendor Page

Use the Recruitment Sources - Vendor page (HRS\_SOURCE\_VNDR) to identify a third-party vendor and enter additional processing rules for vendor recruitment sources.

---

**Note:** This page appears only for recruitment sources with the source type *Vendor*.

---

Navigation:

**Set Up HCM > Product Related > Recruiting > Recruitment Sources > Vendor**

This is the first of two examples illustrating the Vendor page.

Source Setup
Vendor
Contacts

**Source Setup**

Source Name Jobs Express USA

Effective Date 01/01/1900

**Vendor**

Vendor

Site ID

Info URL

**Screening**

Unsolved

Unresolved

Draft

\*On Extraction Failure

Retain Position Association

Notify On Screening

This is the second of two examples illustrating the Vendor page.

**Notifications**

Unresolved

Rejected

Draft

Success

**Extractor**

Default Extractor

Language

Country

## Vendor

<i>Field or Control</i>	<i>Description</i>
<b>Vendor</b>	Select a vendor to which organizations will post job openings or from which they will receive applicants. The only vendors that you can select from are vendors from the JobBoard transaction group.
<b>Site ID</b>	Select the site to which applicants will be redirected when they receive an email notification that requires them to go to an online application site to enter or review information.
<b>Info URL</b> (information uniform resource locator)	Enter the URL that determines where users can go to view the job postings for this source.

## Screening

<i>Field or Control</i>	<i>Description</i>
<b>Unresolved, Reject, and Draft</b>	<p>Select the autoscreen definition that you want to associate with each status. During the autoscreen process, the system processes the statuses in this order:</p> <ol style="list-style-type: none"> <li>1. Reject</li> <li>2. Unresolved</li> <li>3. Draft</li> </ol> <p>The system starts with the first status (Reject) and checks the associated autoscreen definition. If the applicant does not pass the autoscreening criteria, the process stops and the system assigns the Reject status to the resume. If the applicant passes the autoscreening criteria, or if no autoscreening definition is associated with the status, the process moves on to the next status (Unresolved). If the applicant passes all three statuses, the system assigns the status Success to the resume.</p> <p>Before any autoscreening can begin, the extraction process must be successfully complete. Define autoscreening criteria on the AutoScreen Setup page.</p>
<b>On Extraction Failure</b>	Select the status that you want to assign to a resume if resume extraction fails for the resume.

<b>Field or Control</b>	<b>Description</b>
<b>Retain Position Association</b>	Select to have the system retain the job opening with which the resume is associated. This option is valid only for applicants that the system receives through open integration framework. For all other cases, no association with a job opening exists.
<b>Notify On Screening</b>	Select to notify applicants after the screening process is complete. If you select this option, the system uses the values that you specify in the <b>Notifications</b> group box to determine which notification to send.

### Notifications

Use this group box to select the notification that the system sends to each applicant whose based on the autoscreening results. For the system to send these notifications, you must select the **Notify on Screening** option in the **Screening** group box.

PeopleSoft delivers four templates, one for each status. When you create a new source, the system populates each of the fields with the associated notification. If you do not select a notification for a status, the system doesn't send a notification for that status.

These are the default templates:

<b>Field</b>	<b>Notification</b>
<b>Unresolved</b>	HRS_HROI_UNRESOLVED
<b>Rejected</b>	HRS_HROI_REJECTED
<b>Draft</b>	HRS_HROI_DRAFT
<b>Success</b>	HRS_HROI_SUCCESS

### Extractor

<b>Field or Control</b>	<b>Description</b>
<b>Default Extractor</b>	Select the default resume extractor that the system uses for non-XML resumes that come from this source. However, note that you can process resumes through another extractor by using the Manage Resumes (HRS_AL_LOG) component.

<b>Field or Control</b>	<b>Description</b>
<b>Language</b>	Select a language in which the resumes are written. Some resume extractors require a language to begin the extraction process.
<b>Country</b>	Select a country. Some resume extractors require a country to begin the extraction process.

## Recruitment Sources - Contacts Page

Use the Recruitment Sources - Contacts page (HRS\_SOURCE\_CONTACT) to define contacts for all types of recruitment sources.

Navigation:

**Set Up HCM > Product Related > Recruiting > Recruitment Sources > Contacts**

This example illustrates the Recruitment Sources - Contacts page.

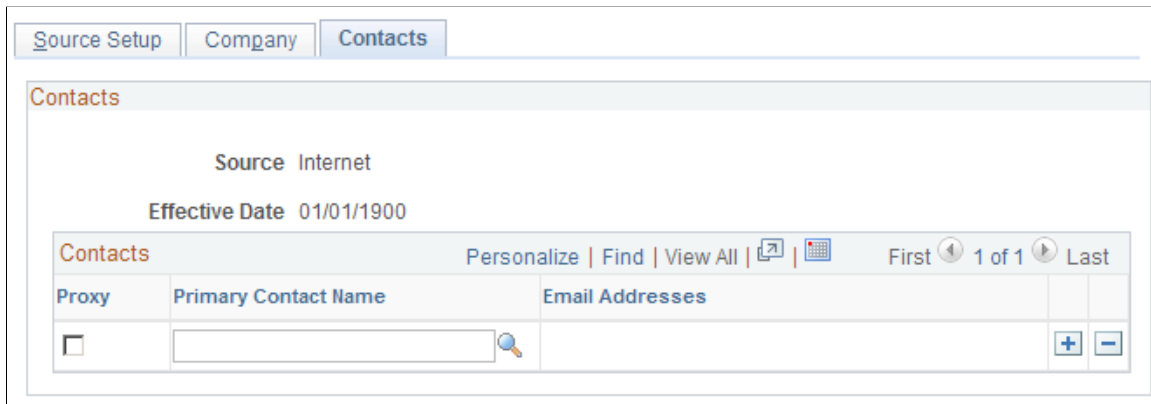

<b>Field or Control</b>	<b>Description</b>
<b>Proxy</b>	<p>Select to have the system create a proxy for incoming applicants from this source. This proxy functionality applies only to Vendor source types.</p> <p>When a staffing supplier submits a resume, it is common not to contact the applicant to whom the resume belongs. Instead, all communication with the applicant, up until the interview with the applicant, is done through the staffing supplier. The person at the staffing supplier organization who handles this duty is referred to as a proxy. The proxy takes on all responsibilities of the applicant and is both responsible and expected to act in the best interest of the applicant. On system pages that show applicant contact information, the contact information for the proxy is also included. When you send correspondence to an applicant who uses a proxy, the system sends the correspondence to the proxy, not the applicant.</p>

<b><i>Field or Control</i></b>	<b><i>Description</i></b>
<b>Primary Contact Name and Email Addresses</b>	Select a contact. You can select from any contact that has a contact type of general. When you select a contact, the system populates the <b>Email Addresses</b> field with the email address of the contact. Define contacts on the Contacts - Contacts Setup page.

# Understanding Approval Delegation in Talent Acquisition Manager

---

## Talent Acquisition Manager Delegations

Talent Acquisition Manager uses delegation to authorize one person to serve as another person's representative when performing the following actions:

- Approving a job opening.
- Approving a Job offer.

There is no special approval processing when the process includes a proxy. The proxy simply replaces the delegator in the chain.

The delegation framework gives the proxy:

- Access to the Pending Approvals page and workflow notifications for pending approvals.

The Maintain Delegated Authority (HCDL\_BATCH) Application Engine process grants the proxy the necessary access. Be sure to run this process regularly.

See “Processing Batch Delegation Requests” (Enterprise Components).

While a delegation is active, the proxy sees the delegated transactions in the Pending Approvals component; when the delegation period ends, any pending approval requests are removed from the proxy's queue and rerouted back to the delegator.

The Maintain Delegated Authority process does not grant access to the Recruiter Alerts pagelet, but if the proxy has access to the pagelet, the delegated approval transactions are also included in the proxy's alerts during the delegation period.

- Access to the Job Opening page through links on the Pending Approvals page and in workflow notifications.

Proxies are given access to the job opening through the Pending Approvals page, but proxies who do not otherwise have direct access to the Job Opening component (for example, using the Search Job Opening page) do not get direct access by virtue of being a proxy.

- Authority to approve, deny, or push back the transaction.

When a proxy takes action, the proxy's name appears in the job opening details as the approver of the job opening or job offer.

- Authority to modify job opening or job offer details, even if not part of the hiring team.

## The Delegation Framework

PeopleSoft HCM applications use a common approval and delegation framework. This overview discusses:

- Delegation terminology.
- Delegation options.
- Delegation framework pages.

**Note:** This overview provides only basic information about the delegation framework. For more complete documentation, see “Understanding Delegation” (Enterprise Components) and its related topics.

## Delegation Terminology

The following terms are important to understanding the delegation feature:

<b>Term</b>	<b>Definition</b>
Delegation	The act of giving one's authority to another user.
Delegator	A person that delegates authority to another user.
Proxy	A person granted authority to act on behalf of another user.
Delegated Authority	The rights and privileges that are given from the delegator to the proxy.
Delegation Request	A request from the delegator to the proxy to take on delegated authority.
Delegation Period	The time range in which the delegated authority is in effect.
Delegation Administrator	The system administrator who is responsible for configuring, managing, and maintaining delegated authorities.
Revoke	When a delegator withdraws delegated authority.

## Delegation Options

The delegation framework supports the following types of delegation:

- Downward delegation of authority to a direct report or another person lower down in the reporting hierarchy.
- Upward delegation of authority to a manager or another person higher up in the reporting hierarchy.



- Lateral delegation of authority to a peer either within the same division or in a different division within the reporting hierarchy.

---

**Note:** To prevent situations of cascading or circular delegation chains, once the delegation framework passes delegated authority over a transaction to a proxy, the proxy cannot delegate authority over that transaction to another user. The delegation framework only passes authority over transactions from initial delegator to initial proxy.

---

## Delegation Framework Pages

Use these pages to review and manage delegation data:

1. Review delegation transactions for workflow on the Register Workflow Transaction page.  
See “Registering Workflow Transactions” (Enterprise Components).
2. Review delegation permission lists and roles through PeopleTools Security components.  
See “Setting Up Permission Lists and Roles for Delegation” (Enterprise Components).
3. Define installation settings for delegation on the Delegation Installation Settings page.  
See “Defining Delegation Installation Settings” (Enterprise Components).
4. Review transactions for delegation on the Configure Delegation Transaction page.  
See “Configuring Delegation Transactions” (Enterprise Components).

---

## Delivered Delegation Definitions for Recruiting

This overview discusses:

- Delivered workflow transactions.
- Delivered permission lists and roles for delegation.
- Installation Settings
- Delivered delegation transactions.

## Delivered Workflow Transactions

Talent Acquisition Manager delivers these two approval transactions that are preconfigured for delegation:

<i>Transaction Name</i>	<i>Transaction Type</i>	<i>Description</i>
JobOpening	Approve	Job opening approval.

<i>Transaction Name</i>	<i>Transaction Type</i>	<i>Description</i>
JobOffer	Approve	Job offer approval.

### Related Links

“Registering Workflow Transactions” (Enterprise Components)

“Linking Workflow Transactions” (Application Fundamentals)

“Setting Up Approval Process Definitions” (Application Fundamentals)

## Delivered Permission Lists and Roles for Delegation

Talent Acquisition Manager delivers permission lists that are required for use of the Delegation framework. This table describes the delivered recruiting roles for the delegation framework:

<i>Role Name</i>	<i>Attached Permission Lists</i>	<i>Description</i>
Delegate_JobOpening_Approve	HCCPDL2021 (Approve Job Opening)	Provides access to the Pending Approvals component and to the pages needed to view job opening details.
Delegate_JobOffer_Approve	HCCPDL2029 (Approve Job Offer)	Provides access to the Pending Approvals component and to the pages needed to view job offer details.

**Note:** Generally, users who can access an existing job opening can create a new job opening using either the Create New or Clone icons at the top of the Job Opening page. However, these icons are hidden from proxies who are not recruiting users. The system determines if a proxy is a recruiting user by comparing the proxy's roles to the roles that you include on the Recruiting Roles page.

See [Recruiting Roles Page](#).

The delegation framework provides additional permission lists for users and administrators of the delegation framework.

- The delegation administrator permission list, HCCPDL1000, is associated with the delivered HCM Delegation Admin role.
- The delegation user permission list, HCCPDL1100, enables delegation users (both delegators and proxies) access to the Manage Delegation home page.

When implementing delegations, make sure that all of your delegation users are associated with this permission list. As delivered, the permission list is associated with the Manager and Employee roles, but you must analyze delegation security requirements based on your organization's security configuration.

### Related Links

“Setting Up Permission Lists and Roles for Delegation” (Enterprise Components)

## Installation Settings

Delegation installation settings control which users can be chosen as proxies. The settings are global (that is, they apply to all applications in your HCM system).

See “Defining Delegation Installation Settings” (Enterprise Components).

## Delivered Delegation Transactions

This table lists the delegation transactions delivered for Talent Acquisition Manager:

<i>Transaction Name</i>	<i>Transaction Type</i>	<i>Role</i>
Job Openings	Approve	Delegate_JobOpening_Approve
Job Offers	Approve	Delegate_JobOffer_Approve

**Note:** All transactions are delivered inactive.

### Related Links

“Configuring Delegation Transactions” (Enterprise Components)

---

## The Delegation Process

This topic provides an overview of delegation through self service.

**Note:** This overview provides only basic information about the delegation framework. For more complete documentation, see “Working with Self-Service Delegation” (Enterprise Components) and its related topics.

### Delegator Delegates Approval Authority

A delegator follows these steps to delegate approval authority:

1. Navigate to the Manage Delegation component (**Self Service > Manage Delegation**).
2. Click the **Create Delegation Request** link.

Delegators who have multiple jobs will have to indicate the job for which they are delegating approvals.

3. Enter **From Date** and **To Date** for the delegation request, then click the **Next** button.
4. Select the transactions to be delegated (job opening approval, job offer approval, or both), then click the **Next** button.
5. Select a proxy.

6. Select the **Notify Delegator** check box, then click **Submit**.
7. Click **OK**.

The system generates a notification to the selected proxy.

### **Proxy Accepts Delegation Request**

A proxy follows these steps to accept approval authority:

1. Navigate to the Manage Delegation component (**Self Service > Manage Delegation**).
2. Click the Review My Delegated Authorities link to access the My Delegated Authorities page.
3. Click the Accept button.

Alternatively, the proxy can click the Reject button to reject the delegation.

### **The Delegation Authority Ends**

The delegator can manually revoke the delegation, or the delegation can end because it has reached its end date. In both cases, any pending approvals are removed from the proxy's queue and added back to the delegator's queue.

## Chapter 13

# Setting Up Searching and Using Global Search

---

## Understanding Recruiting Search Indexes

PeopleSoft Recruiting Solutions uses the PeopleTools Search Framework for several applicant-related and job-related searches.

The *PeopleTools: Search Technology* documentation provides information about configuring the framework itself, while this topic provides information specific to recruiting solutions.

## Recruiting Search Indexes

PeopleSoft Recruiting Solutions uses the PeopleTools Search Framework (which accesses its underlying search engine by way of Integration Broker) to generate search results for various applicant and job searches. To perform searches, the system uses a set of indexes that contain the relevant data, it does not search the database tables directly. The index must be routinely updated to reflect the latest database changes.

Indexes are based on PeopleTools Search Framework *search definitions*, which in turn belong to *search categories*.

Oracle delivers the following search definitions to support recruiting searches:

- HC\_HRS\_APPLICANT
- HC\_HRS\_APP\_INDEX
- HC\_HRS\_JOB\_OPENING
- HC\_HRS\_JOB\_POSTING
- HC\_HRS\_APPLICATION\_CONTENT
- HC\_HRS\_JOB\_CONTENT
- HC\_JPM\_PERSON\_PROFILE (also supports profile searching in PeopleSoft Human Resources)
- HC\_JPM\_NONPERSON\_PROFILE (also supports profile searching in PeopleSoft Human Resources)
- HC\_HRS\_DATA\_MAP

### Related Links

“Understanding Real Time Indexing in HCM” (Application Fundamentals)

## Search Pages and Their Search Objects

The following table lists the recruiting search pages that use the PeopleTools Search Framework and identifies the search definitions and search categories that support each page. The table also identifies which categories are auto-deployed when the search definition is deployed and which categories must be manually deployed.

**Note:** Not all recruiting search pages use the PeopleTools Search Framework. The [Search Applicants Page: Quick Search Tab](#), the [Search Applications Page](#), and the [Search Job Openings Page](#) perform standard database searches rather than PeopleTools Search Framework searches.

<b>Page</b>	<b>Description</b>	<b>Search Definitions</b>	<b>Search Category</b>
<a href="#">Browse Applicants Page</a>	Keyword searching and faceted searches for applicants.	HC_HRS_APPLICANT	HC_HRS_APPLICANT (auto-deployed when index is deployed)
<a href="#">Search Applicants Page: Keyword Search Tab</a>	Keyword searching for applicants.	HC_HRS_APP_INDEX	HC_HRS_APP_INDEX (auto-deployed when index is deployed)
<a href="#">Search Applicants Page: Advanced Search Tab</a>	Advanced searching for applicants.	HC_HRS_APP_INDEX	HC_HRS_APP_INDEX (auto-deployed when index is deployed)
<a href="#">Run Automatch Search Page</a>	Runs an Application Engine process to run saved applicant searches, including keyword searches and advanced searches.	HC_HRS_APP_INDEX	HC_HRS_APP_INDEX (auto-deployed when index is deployed)
<a href="#">Global Search for Applicants</a>	Global search for applicants.	HC_HRS_APP_INDEX	HC_HRS_APP_INDEX_GS (must be manually deployed)  <b>Note:</b> This search definition belongs to two different search categories. The search category for the applicant global search , HC_HRS_APP_INDEX_GS, must be manually deployed. The search category used in for the other applicant searches are auto-deployed.
<a href="#">Browse Job Openings Page</a>	Keyword searching and faceted searches for job openings.	HC_HRS_JOB_OPENING	HC_HRS_JOB_OPENING (auto-deployed when index is deployed)

<b>Page</b>	<b>Description</b>	<b>Search Definitions</b>	<b>Search Category</b>
<p>“Job Search Page” (PeopleSoft Candidate Gateway) (Classic Candidate Gateway)</p> <p>and “Search Jobs Page” (PeopleSoft Candidate Gateway) (Fluid Candidate Gateway)</p>	Applicant-facing job posting search (in Candidate Gateway).	HC_HRS_JOB_POSTING	<p>HC_HRS_CG_JOB_POSTING (must be manually deployed)</p> <hr/> <p><b>Note:</b> This search definition belongs to two different search categories so that different search facets can be used in Candidate Gateway and in Talent Acquisition Manager. The Candidate Gateway search category, HC_HRS_CG_JOB_POSTING, must be manually deployed. The search category used in Talent Acquisition Manager is auto-deployed. See “Understanding Setup for Candidate Gateway Searching” (PeopleSoft Candidate Gateway)</p> <hr/>
<u>Search Job Postings Page</u>	Job posting search in Talent Acquisition Manager	HC_HRS_JOB_POSTING	HC_HRS_JOB_POSTING (auto-deployed when index is deployed)
<u>Global Search for Job Postings</u>	Global search for job postings.	HC_HRS_JOB_POSTING	HC_HRS_JOB_POSTING (auto-deployed when index is deployed)
<u>Search Applicants Page: Profile Match Tab</u>	Search for job openings, applicants, or employees with profiles similar to another job opening, applicant, or employee.	<ul style="list-style-type: none"> <li>• HC_HRS_APPLICATION_CONTENT (applicant profile data)</li> <li>• HC_HRS_JOB_CONTENT (job opening profile data)</li> <li>• HC_JPM_PERSON_PROFILE (employee profile data)</li> <li>• HC_JPM_NONPERSON_PROFILE (nonperson profile data)</li> </ul>	<ul style="list-style-type: none"> <li>• HC_HRS_APPLICATION_CONTENT and HC_HRS_JOB_CONTENT have identically-named search categories that are auto-deployed when index is deployed.</li> <li>• HC_JPM_PERSON_PROFILE and HC_JPM_NONPERSON_PROFILE use the HC_JPM_PROFILES search category, which must be manually deployed.</li> </ul>

<b>Page</b>	<b>Description</b>	<b>Search Definitions</b>	<b>Search Category</b>
“Search My Profile Page” (PeopleSoft Candidate Gateway) (Candidate Gateway)	Internal applicants (employees) use this Candidate Gateway page to search for job openings that match their own profiles.	<ul style="list-style-type: none"> <li>• HC_HRS_JOB_CONTENT (job opening profile data)</li> <li>• HC_JPM_PERSON_PROFILE (employee profile data)</li> <li>• HC_JPM_NONPERSON_PROFILE (nonperson profile data)</li> </ul>	<ul style="list-style-type: none"> <li>• HC_HRS_JOB_CONTENT has an identically-named search categories that is auto-deployed when index is deployed.</li> <li>• HC_JPM_PERSON_PROFILE and HC_JPM_NONPERSON_PROFILE use the HC_JPM_PROFILES search category, which must be manually deployed.</li> </ul>
<u>Unmapped Data Page</u>	Search for data mapping suggestions to facilitate the process of mapping unmapped incoming data to values defined in Data Mapping Categories.	HC_HRS_DATA_MAP	HC_HRS_DATA_MAP (auto-deployed when index is deployed)

## Index Maintenance

PeopleSoft Search Technology provides a search administration interface that you use to deploy search definitions and categories and to schedule index builds. You can build indexes in two modes: full mode or incremental mode. Use the full mode to build an index for the first time or to rebuild it from scratch. After an index has been built, use incremental builds to update it.

PeopleSoft Recruiting Solutions tracks the last updated date and time for all indexed objects. The PeopleSoft Search Framework uses this information to recognize data changes that need to be incorporated into the search index during incremental index builds. The time lag before an index reflects data changes depends on the indexing schedule that the search administrator configures.

See [Deploying and Building Recruiting Search Indexes](#) for instructions on building the recruiting search indexes. For more detailed information about search tools, refer to *PeopleTools: Search Technology*

## Faceted Searching

Several search pages provide faceted searching, where specific fields, or facets, can be used as filters to categorize and narrow down a list of objects. For example, on the Browse Job Openings page, one of the delivered facets is the Hiring Manager field. The Hiring Manager facet displays a list of the primary hiring managers for the job openings listed on the page. Clicking a hiring manager narrows down the list of job openings to include only openings with the selected primary hiring manager.

Search definitions control which fields are available as facets. Before changing the delivered facets, consider that the number of available facets affects performance as well as usability.

Search categories enable you to choose a subset of the available facets to activate. For example, the HC\_HRS\_JOB\_POSTING search definition is used to index job posting data, and several fields are marked as facets. However, this search definition is used in two different pages that offer faceted searching: the Candidate Gateway job posting search, and the recruiter-facing job posting search.



Some facets that are useful to a recruiter, such as the posting type (internal or external), would not be appropriate for an applicant. So the search definition belongs to two search categories, each of which activates a different subset of the available facets.

See [Configuring Recruiting Search Facets](#) for information on modifying facets for recruiting pages.

## Maximum Number of Search Results

The PeopleTools Search Framework and its underlying search engine can have a system-wide setting for the maximum number of search results.

Certain recruiting searches have an additional limit on the number of search results. The system always uses the lower of the system-wide maximum or the search-specific maximum.

The Browse Applicants page and the Browse Job Openings page both have a (non-configurable) maximum of 300 results.

The Candidate Gateway job search has a configurable maximum. To restrict search results to fewer than the system-wide maximum, enter the lower maximum in the Max Jobs Returned from Search field on the [Recruiting Installation – Jobs Page](#).

---

## Defining Search Index Settings for Recruiting

To define which job postings and applicants to include in recruiting search indexes, use the Build Search Index Settings (HRS\_SCHIDX\_SETTING) component.

### Page Used to Define Search Index Settings for Recruiting

<i>Page Name</i>	<i>Definition Name</i>	<i>Usage</i>
<a href="#">Build Search Index Settings Page</a>	HRS_SCHIDX_SETTING	Configure which job postings and which applicants to include in search indexes.

## Understanding Search Framework Days To Include Vs. Recruiting Date Settings

There are two separate ways to specify how recent data must be in order to be included in the job posting or applicant search indexes:

- In the recruiting system, the Build Search Index Settings page includes fields where you enter a “From Post Date” for postings and a “From Application Date” for applicants.
- In the PeopleTools Search Framework, the search definitions for each index include an “Index Only Last *n* Days” field.

To access this field, select **PeopleTools > Search Framework > Designer > Search Definition**. Access the Advanced page, and look in the Full Indexing Criteria group box.

The system reconciles the two settings differently for different types of indexes:

- For job postings, the system ignores the search definition setting and uses only the recruiting setting.  
 Job postings remain searchable as long as they are posted. When a job is no longer posted, it is automatically excluded from the index. Therefore, posting dates are sufficient to ensure that the index does not include any expired postings, and the search definition setting is unnecessary.
- For applicants, the system uses the search definition setting if there is one. The recruiting setting is used only if the search definition setting is blank.

## Build Search Index Settings Page

Use the Build Search Index Settings page (HRS\_SCHIDX\_SETTING) to configure which job postings and which applicants to include in search indexes.

Navigation:

**Recruiting > Administration > Build Search Index Settings**

This example illustrates the Build Search Index Settings page.

### Build Search Index Settings

**Job Search Index**

From Post Date

**Applicant Search Index**

From Application Date

Applicant Status	
Select	Description
<input checked="" type="checkbox"/>	010 Active
<input checked="" type="checkbox"/>	020 Hired
<input checked="" type="checkbox"/>	030 Inactive
<input checked="" type="checkbox"/>	040 Queued

### Job Search Index

These settings apply to the two job posting indexes: HC\_HRS\_JOB\_POSTING and HC\_HRS\_JOB\_CONTENT.

<b>Field or Control</b>	<b>Description</b>
<b>From Post Date</b>	<p>When the system builds or updates the job posting indexes, it includes job postings that were posted on or after the date you enter in this field.</p> <p>If you leave this field blank, the index includes all job postings for job openings that:</p> <ul style="list-style-type: none"> <li>• Have an open status.</li> <li>• Have been posted internally or externally to a destination that is a Company recruitment source type.</li> </ul> <hr/> <p><b>Note:</b> For job posting indexes, the system does not look at the setting within the PeopleTools Search Framework search definition that specifies the number of days of data to include in the index.</p>

### Applicant Search Index

These settings apply to the three applicant indexes: HC\_HRS\_APP\_INDEX, HC\_HRS\_APPLICANT, and HC\_HRS\_APPLICATION\_CONTENT.

<b>Field or Control</b>	<b>Description</b>
<b>From Application Date</b>	<hr/> <p><b>Important!</b> For applicant indexes, the setting within the PeopleTools Search Framework search definition that specifies the number of days of data to include in the index supersedes any date that you enter here.</p> <hr/> <p>If the search definition for an applicant index does not already specify the number of days of data to include in the index, the index includes only applications that were submitted on or since the date you enter in this field.</p> <p>If you leave this field blank and the search definition doesn't specify how many days to include, then all applications are included in the indexes.</p>

<b>Field or Control</b>	<b>Description</b>
<b>Applicant Status</b>	<p>Select which applicant statuses to include in the applicant-related search indexes. You must select at least one status. By default, all check boxes are selected.</p> <p>The selection grid shows all statuses that have been defined for the Applicant recruitment area. The four statuses that PeopleSoft delivers are <b>Active</b>, <b>Hired</b>, <b>Inactive</b>, and <b>Queued</b>.</p> <p>Applicant who are not included in the indexes are still searchable using the Search Applicants page: Quick Search tab (the database search for applicants). If you want consistency among all types of searches, you can include all available statuses in the index. However, when there are large numbers of applicants in the system, you can improve the search performance by including fewer applicants (for example, only active applicants).</p> <hr/> <p><b>Note:</b> On the Search Applicants page, the advanced search gives users the option to exclude selected statuses from search results. The list of statuses that appears on the Advanced Keyword Search page include all statuses, regardless of whether which statuses are included in the applicant indexes.</p> <hr/>

---

## Building Recruiting Search Indexes

Use the PeopleTools Search Framework to manage recruiting search indexes. This topic discusses how to:

- Deploy and build search indexes.
- Configure search facets.

---

**Note:** The *PeopleTools: Search Technology* documentation provides information about configuring the framework itself, while this topic provides information specific to recruiting solutions.

---

## Deploying and Building Recruiting Search Indexes

To create search indexes for recruiting:

1. Deploy the recruiting search definitions.

Navigate to **PeopleTools > Search Framework > Administration > Deploy/Delete Object** to access the Deploy Search Definition page. Then select the recruiting search definitions and click the Deploy button.

2. Deploy any search categories that were not auto-deployed.

Access the Deploy Search Category page (in the same component as the Deploy Search Definition page). Then select the desired search categories and click the Deploy button.

As delivered, the system auto-deploys most recruiting search categories when the corresponding search index is deployed. But these search categories are must be manually deployed:

- The HC\_HRS\_CG\_JOB\_POSTING category for Candidate Gateway job searches.
- The HC\_JPM\_PROFILES category for profile searches.
- The HC\_HRS\_APP\_INDEX\_GS category for the global search for applicants.

### 3. Build the Search Index.

Navigate to **PeopleTools > Search Framework > Administration > Schedule Search Index** to access the Build Search Index page. Use this page to schedule the index build process and to indicate whether to run a full indexing process or an incremental indexing process.

You must run a full indexing process to create an index when none exists. After the index is created, you can schedule periodic incremental builds to keep the index current.

## Configuring Recruiting Search Facets

To modify the facets on a search page, update the facet settings on the search definition and the search category. The following table identifies the search definitions and search categories for the faceted searches in the recruiting system:

<b>Search Page</b>	<b>Search Definition</b>	<b>Search Category</b>
<a href="#">Browse Applicants Page</a>	HC_HRS_APPLICANT	HC_HRS_APPLICANT
<a href="#">Global Search for Applicants</a>	HC_HRS_APP_INDEX	HC_HRS_APP_INDEX_GS
<a href="#">Browse Job Openings Page</a>	HC_HRS_JOB_OPENING	HC_HRS_JOB_OPENING
<a href="#">Global Search for Job Postings</a>	HC_HRS_JOB_POSTING	HC_HRS_JOB_POSTING
“Job Search Page” (PeopleSoft Candidate Gateway) (Classic Candidate Gateway) and “Search Jobs Page” (PeopleSoft Candidate Gateway) (Fluid Candidate Gateway)	HC_HRS_JOB_POSTING	HC_HRS_CG_JOB_POSTING

To modify the facets for a search definition:

1. Navigate to the Deploy Search Definitions component (**PeopleTools > Search Framework > Administration > Deploy/Delete Object**) and undeploy the search definition and search category.

2. Navigate to the Search Definition component (**PeopleTools > Search Framework > Designer > Search Definition**) and access the search definition to be modified.
3. Access the Map Search Attributes page.
4. In the **Fields Included in the Index** grid, select or deselect check boxes in the **Is Faceted** column to add or remove facets.
5. Save your changes.
6. Navigate to the Search Category definition (**PeopleTools > Search Framework > Designer > Search Category**) and access relevant the search category

---

**Note:** The HC\_HRS\_JOB\_POSTING search definition is associated with two search categories. Be sure to select the correct one depending on whether you are configuring the Candidate Gateway job search or the global search for job postings.

---

7. Access the Facets page.
8. Add or remove facets from the facet list.

To automatically add all facets from the related search definition(s), deselect the **Auto detect facets** check box, save, then re-select the **Auto detect facets** check box and save again. This removes disabled facets from the grid and add newly enabled facets to the grid.

---

**Important!** Do not use this method with the HC\_HRS\_CG\_JOB\_POSTING category because the related search definition (which is associated with multiple job categories) includes facets that should not be used for the Candidate Gateway job search. Instead, manually add a single row to the Facets grid, then manually select the facet name.

---

9. For a date range facet such as the “Jobs Posted Within” or “Job Closing In” facet for Candidate Gateway (in the HC\_HRS\_CG\_JOB\_POSTING category), click the Advanced Settings link to define relative date options such as *Last Week*

Date range facets require PeopleTools 8.54 or later. For detailed information about the appropriate advanced facet settings for the Jobs Posted Within and Job Closing In facets, refer to the next section in this topic.

---

**Note:** The required PeopleTools version for Fluid Candidate Gateway ensures that Fluid Candidate Gateway implementations always support the settings described here. However, Classic Candidate Gateway also runs on earlier versions of PeopleTools that do not support advanced settings for facets.

---

10. Redeploy the search definition and search category, then rebuild the search index.

## Date Facet Configuration for Candidate Gateway

If you are using PeopleTools 8.54 or later, advanced settings for date facets enable you to set up filters consisting of relative date ranges such as *Within the Last Week* or *In less than 7 days*. Oracle suggests using these settings to configure the following Candidate Gateway facets for greater usability:

- Configure the Jobs Posted Within facet to use filter values such as *Last Week*, *Last Month*, and so forth.

- Configure the Job Closing In facet to use filter values such as *Less than 7 days*, *Less than 30 days*, and so forth.

This configuration is recommended for Fluid Candidate Gateway when the system is configured to display the Close Date field on the Search Jobs page.

The previous section in this topic lists the overall steps for configuring facets. This section shows the recommended advanced settings for the two Candidate Gateway date facets.

## Jobs Posted Within Facet

The delivered facet for the posting date in Candidate Gateway is the *Jobs Posted In* facet, which filters postings by year and then by month.

This example illustrates the delivered Jobs Posted In facet in Classic Candidate Gateway. Initially, this facet lists years. When a user filters using a specific year, the facet lists months.

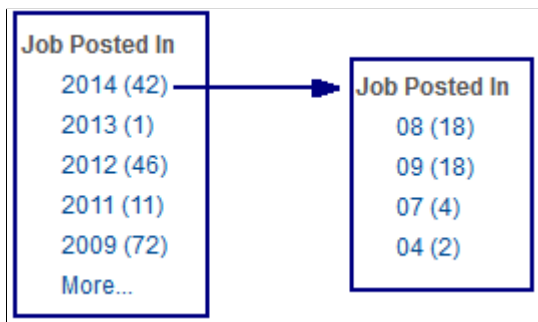

The facet is delivered this way to support Classic Candidate Gateway implementations that use older versions of PeopleTools.

If you are using Fluid Candidate Gateway, or if you use Classic Candidate Gateway on PeopleTools 8.54 or later, Oracle suggests removing the delivered facet and replacing it with the *Jobs Posted Within* facet, which you can configure to for relative dates such as *Last Week*.

This example illustrates the Jobs Posted Within facet in Classic Candidate Gateway.



To set up the *Jobs Posted Within* facet, use the Advanced Facet Settings page to define the relative date ranges to use.

This example illustrates the Advanced Facet Settings page with the appropriate data for the Jobs Posted Within facet.

Enter *Predefined* as the sort order, then enter the following information in the Date Range grid. Note that you do not enter anything in the Node Name field because the node name comes from the Message Number.

Seq.	Range Type	Begin Operator	Begin No	Begin Range	End Operator	End No	End Range	Message Set Number	Message Number
1	Relative	Greater Than or Equals	7	Days Before	Less Than	1	Days From Now	18178	1230 (Last Week)
2	Relative	Greater Than or Equals	1	Months Before	Less Than	1	Days From Now	18178	1231 (Last Month)
3	Relative	Greater Than or Equals	3	Months Before	Less Than	1	Days From Now	18178	1232 (Last Three Months)
4	Relative	Greater Than or Equals	1	Years Before	Less Than	1	Days From Now	18178	1233 (Last Year)



<b>Seq.</b>	<b>Range Type</b>	<b>Begin Operator</b>	<b>Begin No</b>	<b>Begin Range</b>	<b>End Operator</b>	<b>End No</b>	<b>End Range</b>	<b>Message Set Number</b>	<b>Message Number</b>
5	Relative	Not Applicable	Blank	Blank	Less Than	1	Days From Now	18178	1234 (Anytime)

### Job Closing In Facet

If you configure Fluid Candidate Gateway to display the close date for each posting, consider setting up the Job Closing In facet so that applicants can filter jobs based on the close date.

**Note:** Fluid and Classic Candidate Gateway use the same search category and the same facet settings. However, Classic Candidate Gateway cannot be configured to show the posting close date. Although organizations that use Classic Candidate Gateway can still configure the closing date facet to appear, doing so could confuse applicants because they cannot see the close dates for individual job postings.

When you set up the *Job Closing In* facet using the instructions in this topic, you use the Advanced Facet Settings page to define the relative date ranges to use.

This example illustrates the Advanced Facet Settings page with the appropriate data for the Job Closing In facet. The Date Range data is also described in the following table.

The screenshot shows the 'Advanced Facet Settings' interface. At the top, it displays 'Facet Name: HRS\_JO\_PST\_CLS\_DT\_FCT\_PST\_CLS\_DT' and 'Data Type: Date'. Below this, there are options for 'Override default settings', 'Minimum Document Count' (set to 0), and 'Disable Facet Count'. A 'Sort Order' section shows 'Sort as' set to 'Predefined' and 'Sort order' set to '1'. A 'System' section contains various time-based filters like 'Today', 'Yesterday', 'This Week', etc. The 'Date Range' section is a table with the following data:

Sequence	Node Name	Range Type	Begin Operator	Begin Date	Begin No	Begin Range	End Operator	End Date	End No	End Range	Message Set Number	Message Number
1	Less than 7 days	Relative	Not Applicable				Less Than Equals		7	Days from now	18178	1359
2	Less than 30 days	Relative	Not Applicable				Less Than Equals		30	Days from now	18178	1360
3	More than 30 days	Relative	Greater Than		30	Days from now	Not Applicable				18178	1361

Enter *Predefined* as the sort order, then enter the following information in the Date Range grid. Note that you do not enter anything in the Node Name field because the node name comes from the Message Number.

<b>Seq.</b>	<b>Range Type</b>	<b>Begin Operator</b>	<b>Begin No</b>	<b>Begin Range</b>	<b>End Operator</b>	<b>End No</b>	<b>End Range</b>	<b>Message Set Number</b>	<b>Message Number</b>
1	Relative	Not Applicable	<blank>	<blank>	Less Than Equals	7	Days From Now	18178	1359 (Less than 7 days)
2	Relative	Not Applicable	<blank>	<blank>	Less Than Equals	30	Days From Now	18178	1360 (Less than 30 days)
3	Relative	Greater Than	30	Days from now	Not Applicable	<blank>	<blank>	18178	1361 (More than 30 days)

---

## Understanding Global Search for Recruiting

This topic provides an overview of using PeopleSoft Global Search to search for applicants and job postings.

For more information about PeopleSoft Global Search, including a list of search definitions that support Global Search, see “Understanding PeopleSoft Search Framework Implementation for HCM” (Application Fundamentals) and “Using Global Search Definitions for HCM” (Application Fundamentals).

## Recruiting and PeopleSoft Global Search

PeopleSoft Global Search, initiated from a global search bar, provides an alternate navigation mechanism that bypasses PeopleSoft menu navigation. As delivered, Global Search supports two recruiting searches: an applicant search and a job posting search.

The search results page for a global search includes:

- Links for accessing the data in the appropriate component
- A related actions menu that provides quick access to additional pages.
- Facets for narrowing search results.

---

**Note:** Many recruiting pages include a **Return** toolbar button for navigating to the previous page. This button does not recognize the global search results page as the previous page. To return to global search results, click the **Last Search Results** link in the global search bar.

---

## Search Indexes and Search Categories

PeopleSoft Global Search uses the PeopleTools Search Framework and its underlying search engine. Deploy and build the following search indexes to support Global Searches for recruiting:

- The Global Search for applicants uses the HC\_HRS\_APP\_INDEX search definition and the HC\_HRS\_APP\_INDEX\_GS search category. The search category must be manually deployed after you deploy the search definition.
- The Global Search for job postings uses the HC\_HRS\_JOB\_POSTING search definition and the same-named search category. The search category is auto-deployed when the search definition is deployed.

## Permission Lists

Access to the recruiting global searches is available based on these roles and permission lists:

<b>Search Type</b>	<b>Permission List</b>	<b>Delivered Roles With This Permission List</b>
Applicant	HCCPRS1321	<ul style="list-style-type: none"> <li>• Recruiter</li> <li>• Recruiting Manager</li> <li>• Recruitment Administrator</li> </ul>
Job Posting	HCCPRS1320	<ul style="list-style-type: none"> <li>• Recruiter</li> <li>• Recruiting Manager</li> <li>• Recruitment Administrator</li> <li>• Hiring Manager</li> <li>• Applicant</li> </ul>

## Global Search for Applicants

This section describes the search results when you use Global Search to search for applicants.

This example shows search results from a Global Search for applicants. In this example, the related actions menu is expanded so that you can see the available actions.

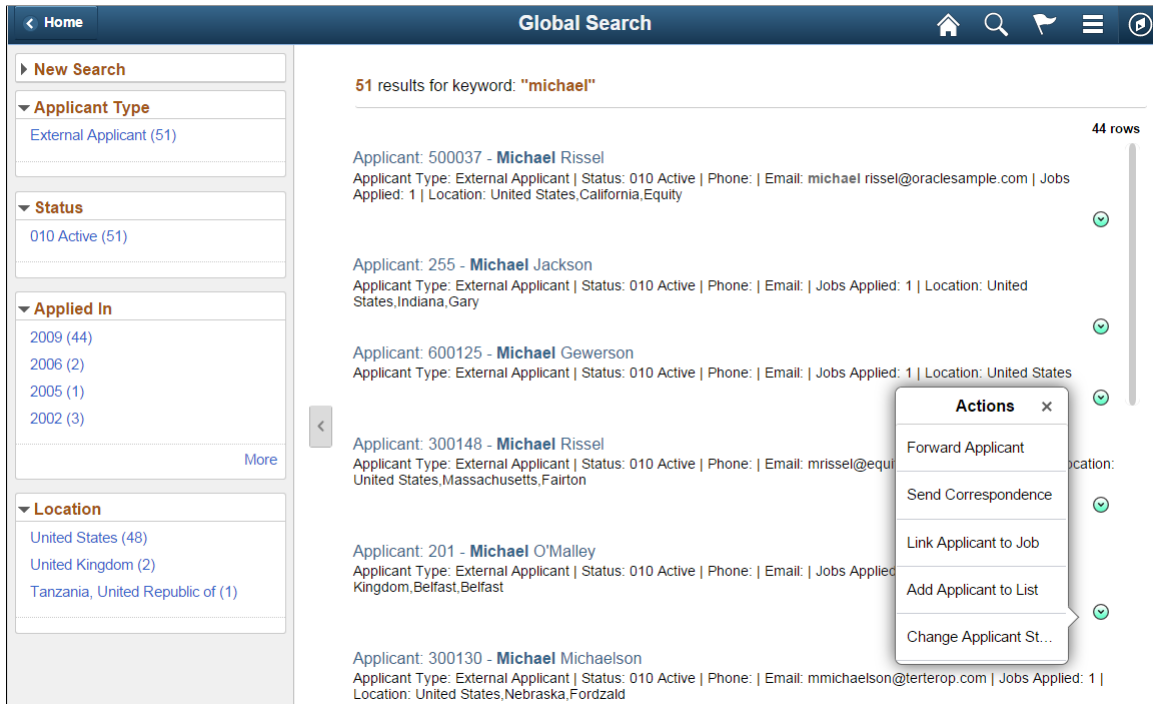

The following table describes the results of a Global Search for applicants.

<b>Applicant Search Results Area</b>	<b>Description</b>
Page accessed when you click the link for a search result.	<a href="#">Manage Applicant Page.</a>
Related actions	<ul style="list-style-type: none"> <li>• Forward Applicant</li> <li>• Send Correspondence</li> <li>• Link Applicant to Job</li> <li>• Add Applicant to List</li> <li>• Change Applicant Status</li> </ul> See <a href="#">Understanding Actions for Managing Applicants.</a>

<b><i>Applicant Search Results Area</i></b>	<b><i>Description</i></b>
Facets	<ul style="list-style-type: none"> <li>• Applicant Type</li> <li>• Status  This is the overall applicant status, not the disposition.</li> <li>• Applied In  This field offers hierarchical filtering based first on the year that the application was created and then, after you select a year, based on the month that the application was created.</li> <li>• Location  This field offers hierarchical filtering based first on the applicant's country, then state or province, then city.</li> </ul>

## Global Search for Job Postings

This section describes the search results when you use Global Search to search for job postings.

This example shows search results from a Global Search for job postings. In this example, the user is a recruiter who can see both internal and external postings. The related actions menu for an internal posting is expanded so that you can see the available actions. The presence of the Manage Job Opening action indicates that the user has access to the Manage Job Opening page (and to the specific job opening). The presence of the other related actions indicates that the user has access to Candidate Gateway pages.

This example shows the PeopleSoft Fluid User Interface version of the search results page.

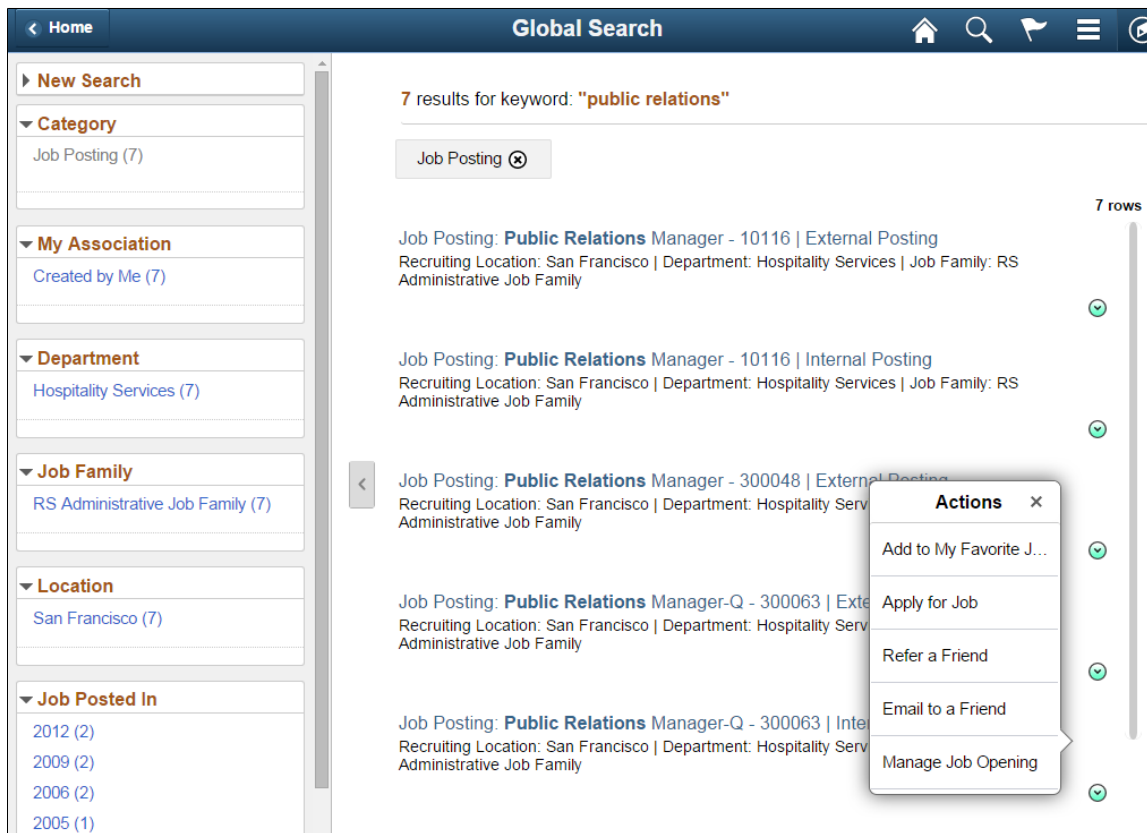

Note that a job opening can have multiple postings. For example, the search results can show both an internal posting and an external posting for the same job opening. However, non-recruiters do not see external postings in their search results.

The following table describes the results of a Global Search for job postings.

<b>Job Posting Search Results Area</b>	<b>Description</b>
Page accessed when you click the link for a search result.	The link goes to different pages depending on the user: <ul style="list-style-type: none"> <li>• If the user has access to Talent Acquisition Manager pages (for example, through the delivered <i>Recruiter</i> role), then the link goes to the recruiter-facing <a href="#">View Job Posting Page</a>.</li> <li>• If the user has access to Candidate Gateway pages (for example, through the delivered <i>Applicant</i> role), but the user does not have access to the Talent Acquisition Manager pages, then the link goes to the applicant-facing Job Description page..</li> </ul>

<b>Job Posting Search Results Area</b>	<b>Description</b>
Related actions	<p>If the user has access to Candidate Gateway pages and the posting is internal, these actions are available:</p> <ul style="list-style-type: none"> <li>• Add to My Favorite Jobs</li> <li>• Apply for Job</li> <li>• Refer a Friend</li> <li>• Email to a Friend</li> </ul> <p>These are the same actions that applicants can perform on the Job Description page in Candidate Gateway.</p> <p>If the user has access to the Manage Job Opening page and the user has security access the job opening, then the <b>Manage Job Opening</b> action is also available. This action provides direct access to the <a href="#">Manage Job Opening Page</a>.</p>
Facets	<ul style="list-style-type: none"> <li>• My Association <ul style="list-style-type: none"> <li>Options include <i>Created by Me, Recruiter, Team Member, Hiring Manager, Primary Hiring Manager, Primary Recruiter, and Applied Jobs</i> (jobs I applied for).</li> </ul> </li> <li>• Recruiting Location <ul style="list-style-type: none"> <li>This is the job opening's primary recruiting location.</li> </ul> </li> <li>• Jobs Posted In <ul style="list-style-type: none"> <li>This field offers hierarchical filtering based first on the year that the job posting was posted and then, after you select a year, based on the month that it was posted.</li> </ul> </li> <li>• Full/Part Time Status</li> <li>• Regular/Temporary Position</li> <li>• Desired Shift</li> </ul>

## Advanced Searches

The Global Search includes an advanced search mode that you access by clicking the **More** link in the **New Search** area of the Search Results page. A generic advanced search is used when the search type is *All*, but if you select *Applicant* or *Job Posting* as the search type, the system uses other recruiting pages for the advanced search:

For the *Applicant* search type, the system displays the [Search Applicants Page: Quick Search Tab](#).

For the *Job Posting* search type, the system displays different pages to different users:

- Users with access to Talent Acquisition Manager pages see the Advanced Search tab on the recruiter-facing [Search Job Postings Page](#).

- Users with access to classic Candidate Gateway pages (who do not also have access to Talent Acquisition Manager pages) see the Advanced Search tab on the Candidate Gateway “Job Search Page” (PeopleSoft Candidate Gateway).



# Using Recruiting Pagelets, Pivot Grids, and the Recruiting Home

---

## Understanding the Recruiting Home

The Recruiting Home displays various pagelets that together provide a dashboard view of recruiting activities. The pagelets that are delivered for the Recruiting Home provide:

- Summary information about your job openings and (for recruiters) your applicants.
- Alerts that summarize additional recruiting information.
- A quick view of today's interview schedule.
- Links to the most frequently used recruiting pages.
- Quick keyword searches for job openings and applicants.
- A chart showing monthly average time to fill rates.
- Access to actionable operational analytics in the form of pivot grids.

This Talent Acquisition Manager overview video includes a demonstration of the Recruiting Home page:

Video: [Talent Acquisition Manager Overview](#)

Personalization links on the Recruiting Home page enable you to choose the content and layout of the pagelets on the page. Many of the individual pagelets also provide personalization options to control the pagelet content.

You can access the Recruiting Home from the Recruiting menu and from the **Recruiting Home** link that appears in the toolbars at the top of many recruiting pages.

This example illustrates the Recruiting Home page.

The screenshot displays the Recruiting Home dashboard. On the left, there is a 'Quick Links' sidebar with options like 'Browse Applicants', 'Browse Job Openings', 'Search Applicants', 'Create Applicant', 'Create Job Opening', 'Applicant Lists', 'Interview Calendar', 'Pending Approvals', and 'Saved Searches'. Below this is a 'Time to Fill' chart showing average days. The main area is divided into three sections: 'My Job Openings' (a table with columns for Job Opening, Recruiting Location, Category, Hiring Manager, Days Open, No Action Taken, and Total Applicants), 'My Applicants' (a table with columns for Applicant ID, Name, Phone, Jobs Applied, Last Job Applied To, Resume, Application, and Print), and 'My Alerts' (a list of alerts such as '2 New Applicants', '5 Unevaluated Answers', '19 Interview Evaluations', etc.). There are also sections for 'Today's Interviews' and 'My Applicant Lists'.

## Defining the Content and Layout of the Recruiting Home

This topic discusses how end users can personalize the content and layout of the Recruiting Home by adding and removing specific recruiting pagelets. It also briefly discusses how to use PeopleTools to change the pagelet options for the Recruiting Home.

### Related Links

[Viewing the Recruiting Home Pagelets](#)

[Viewing the Recruiting Manager Summary Pagelet](#)

[Viewing Classic Recruiting Pagelets](#)

## Pages Used to View and Personalize the Recruiting Home

<b>Page Name</b>	<b>Definition Name</b>	<b>Usage</b>
<a href="#">Recruiting Home Tile</a>	HC_HRS_RECRUITING_HOME_TILE (cref of the tile)	Access the Recruiting Home page.
<a href="#">Recruiting Home Page</a>	HC_HRS_RECRUITING_HOMEPAGE_TAB	View frequently-accessed recruiting information such as important alerts, applicant and job opening lists, and interview schedules. This information appears on various pagelets that are gathered together in a dashboard format.

<b>Page Name</b>	<b>Definition Name</b>	<b>Usage</b>
<u>Personalize Content Page</u>	PORTAL_HPCOMP	Choose which pagelets to include on the Recruiting Home page.
<u>Personalize Layout Page</u>	PORTAL_HPLAYOUT	Choose where to position the pagelets on the Recruiting Home page.

## Recruiting Home Tile

Administrators use the Recruiting Home tile to access the Recruiting Home page.

Navigation:

The Recruiting Home tile is delivered as part of the Talent Administrator home page, but the location can change if you change the delivered home pages or if administrators personalize their home pages.

This example illustrates the Recruiting Home tile.

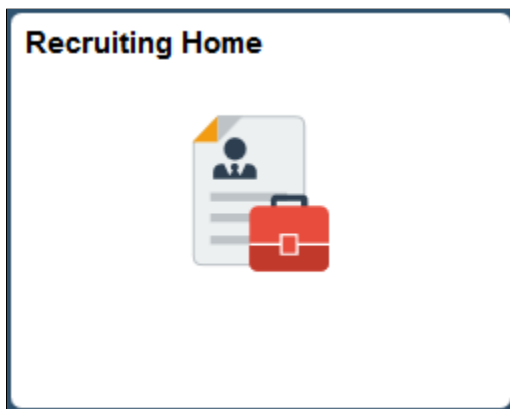

Click the Recruiting Home tile to access the Recruiting Home page.

## Recruiting Home Page

Use the Recruiting Home page (HC\_HRS\_RECRUITING\_HOMEPAGE\_TAB) to view frequently-accessed recruiting information such as important alerts, applicant and job opening lists, and interview schedules. This information appears on various pagelets that are gathered together in a dashboard format.

Navigation:

- **Recruiting > Recruiting Home**
- Click the Recruiting Home tile on the Talent Administrator home page.

This example illustrates the Recruiting Home page.

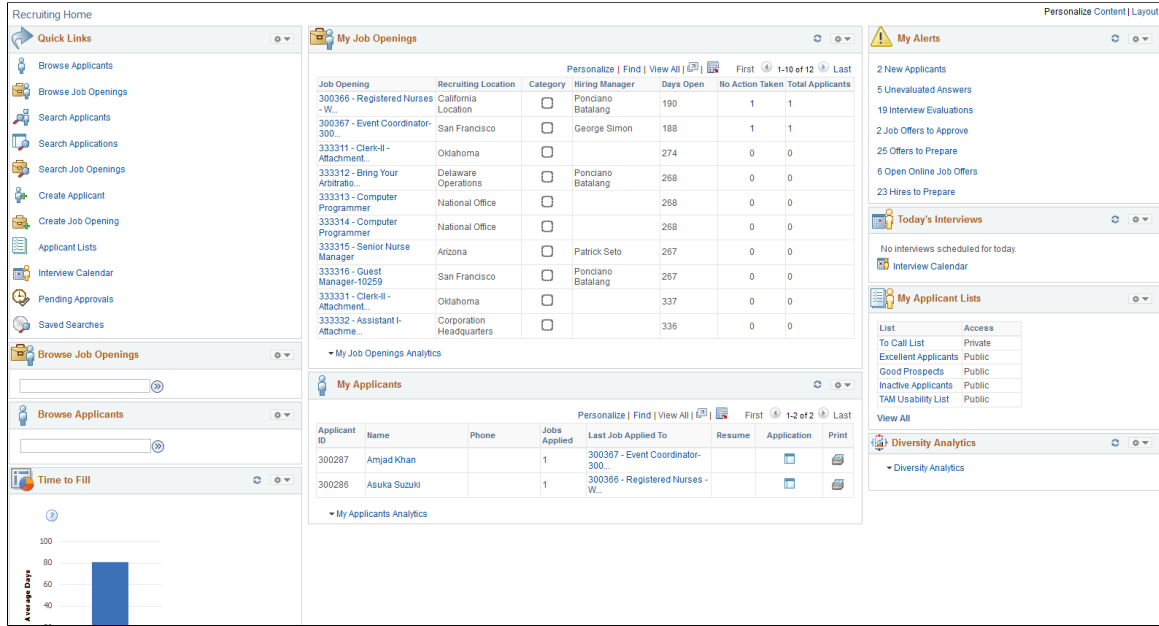

### Personalization Controls

Field or Control	Description
<b>Personalize Content</b>	Click to access the <a href="#">Personalize Content Page</a> , where you can choose which pagelets to include on the Recruiting Home page. As delivered, all Recruiting Home pagelets can be removed through personalization.
<b>Personalize Layout</b>	Click to access the <a href="#">Personalize Layout Page</a> , where you can choose where to position the pagelets on the Recruiting Home page.

### Pagelet Controls

These controls appear in pagelet title bars.

Field or Control	Description
	Click the <b>Refresh</b> icon to refresh data in pagelets that show real-time information. The Quick Links, Browse Job Openings, and Browse Applicants pagelets do not have this icon.

<b>Field or Control</b>	<b>Description</b>
	<p>Click the Pagelet Settings icon to display a menu of possible actions.</p> <ul style="list-style-type: none"> <li>• <b>Personalize:</b> Select this option to access options for configuring the pagelet content.</li> </ul> <p>Not all pagelets have personalization options.</p> <ul style="list-style-type: none"> <li>• <b>Minimize or Expand</b></li> <li>• <b>Remove</b></li> </ul>

## Pagelets

For information about specific pagelets, see [Viewing the Recruiting Home Pagelets](#) and [Viewing Classic Recruiting Pagelets](#)

## Personalize Content Page

Use the Personalize Content page: Recruiting Home (PORTAL\_HPCOMP) to choose the pagelets to include on the Recruiting Home page.

Navigation:

- Click the Personalize Content link at the top of the Recruiting Home page.
- Click the Personalize Content link on the Personalize Layout page.

This example illustrates the Personalize Content page for the Recruiting Home.

Personalize Home Page
✕

New Window

---

**Personalize Content:**

---

Tab Name

Welcome Message

Choose Pagelets: Simply check the items that you want to appear on your homepage.  
Remember to click "Save" when done.

Arrange Pagelets: [Go to](#)      [Personalize Layout](#)

**Recruiting Solutions**

- Quick Links
- My Alerts
- My Job Openings
- My Applicants
- My Applicant Lists
- Today's Interviews
- Time to Fill
- Recruiting Manager Summary
- Browse Job Openings
- Browse Applicants
- Diversity Analytics

**Recruiting Solutions (Classic)**

- My Job Openings (Classic)
- Search Job Openings (Classic)
- Search Applications (Classic)
- Recent Job Openings (Classic)
- Quick Search (Classic)

---

Save
Cancel

<b>Field or Control</b>	<b>Description</b>
<b>Recruiting Solutions</b>	<p>The pagelets listed in the Recruiting Solutions group make up the standard Recruiting Home dashboard. As delivered, the Recruiting Home does not display the Recruiting Manager Summary pagelet. The option to display the <b>Recruiting Manager Summary</b> pagelet is visible only to users with the Recruiting Manager role.</p> <p>These pagelets are described in the topics <a href="#">Viewing the Recruiting Home Pagelets</a> and <a href="#">Viewing the Recruiting Manager Summary Pagelet</a>.</p>
<b>Recruiting Solutions (Classic)</b>	<p><b>Note:</b> The five pagelets listed in the Recruiting Solutions (Classic) group are older pagelets. These are available to add to the Recruiting Home dashboard if users of previous releases prefer to work with pagelets that are they are more familiar with.</p> <p>These pagelets are described in the topic <a href="#">Viewing Classic Recruiting Pagelets</a></p>

## Changing Recruiting Home Pagelet Options

Use the portal structure and content pages in PeopleTools to change which pagelets are available on the Recruiting Home, which pagelets are optional or required, and which pagelets are shown by default.

To change the Recruiting Home pagelet options:

1. Select **PeopleTools > Portal > Structure and Content**
2. From the structure and content root, navigate the folder hierarchy by clicking **Portal Objects > Homepage > Tabs.**
3. In the Content References grid, click the Edit link for the Recruiting Home.
4. Access the Tab Content page, where you can change which pagelets are available on the Recruiting Home, which pagelets are optional or required, and which pagelets are shown by default.

## Personalize Layout Page

Use the Personalize Layout page: Recruiting Home (PORTAL\_HPLAYOUT) to modify the positions of pagelets on the Recruiting Home page.

Navigation:

- Click the Personalize Layout link at the top of the Recruiting Home page.
- Click the Personalize Layout link on the Personalize Content page.

This example illustrates the Personalize Layout page for the Recruiting Home.

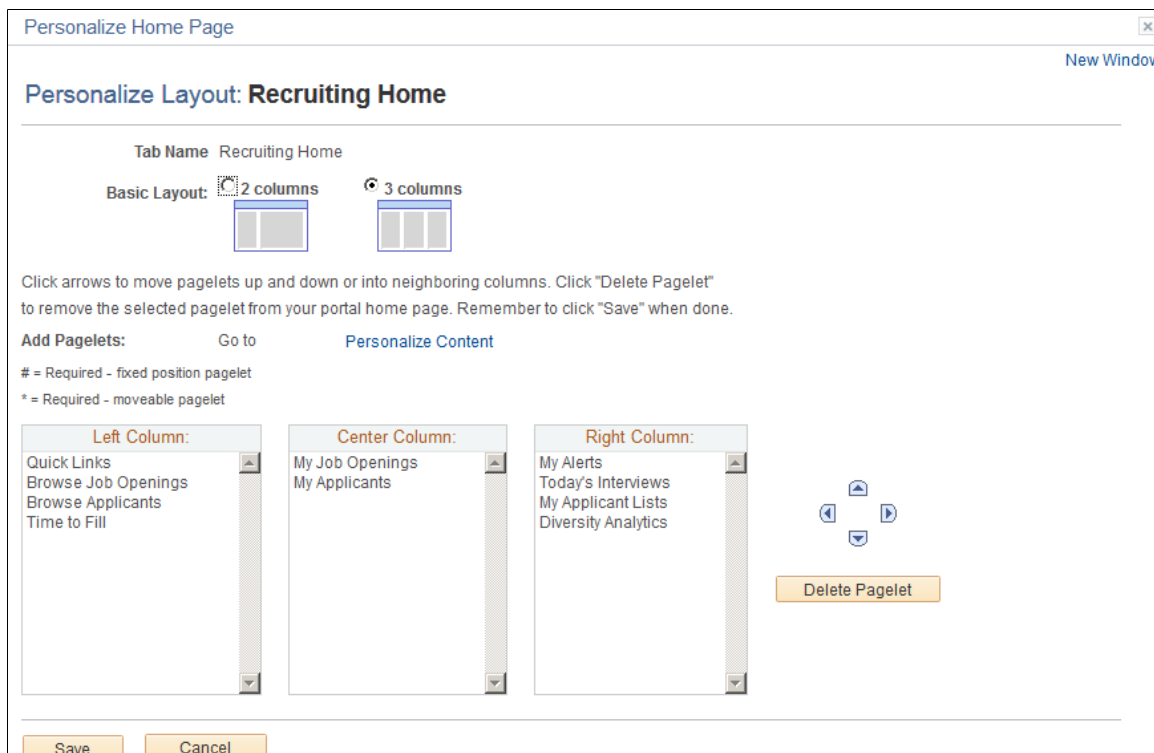

Because a column of pagelets is as wide as the widest pagelet, you can prevent the Recruiting Home page from growing too wide by placing all wide pagelets in the same column. The three wide pagelets are:

- My Job Openings
- My Applicants
- Recruiting Manager Summary

---

**Note:** The Recruiting Manager Summary pagelet is available only to recruiting managers. Recruiting Managers may prefer to place this pagelet on their PeopleSoft home page rather than using the Recruiting Home.

---

## Viewing the Recruiting Home Pagelets

This topic provides an overview of the Recruiting Home pagelets, then provides detailed information about each pagelet and its personalization options.

### Recruiting Home Pagelets and Their Personalization Pages

This table provides summary information about the pagelets that appear on the Recruiting Home in its delivered default state.

---

**Note:** Recruiting pagelets have been replaced by tiles on the Recruiting home page in Fluid. For more information, see [Using the Recruiting Homepage](#).

---

<b>Pagelet Name</b>	<b>Description</b>	<b>Personalization Page</b>
<a href="#">Quick Links Pagelet</a> (HRS_QUICK_LINKS)	Provides links to the most commonly used recruiting components	None
<a href="#">My Alerts Pagelet</a> (HRS_PE_ALHRSTS)	Provides recruiters with summary information for the recruiters own job openings, and provides links to more detailed information.	Use the <a href="#">Personalize My Alerts Page</a> (HRS_PE_OPR_ALERT) to choose the types of alerts to include on the My Alerts pagelet, and provide additional filtering criteria for certain alerts.
<a href="#">My Job Openings Pagelet</a> (HRS_PE_MY_JOBS)	Lists jobs openings to which the user has access and provides key information about each job opening.	Use the <a href="#">Personalize My Job Openings Page</a> (HRS_PE_OPR_MYJOBS) to set filter options to control which job openings appear on the My Job Openings pagelet.
<a href="#">My Applicants Pagelet</a> (HRS_PE_MY_APPS)	Lists applicants who are associated with the user's job openings and provides key information about each applicant.	Use the <a href="#">Personalize My Applicants Page</a> (HRS_PE_OPR_MYAPPS) to set filter options to control which applicants appear on the My Applicants pagelet.



<b>Pagelet Name</b>	<b>Description</b>	<b>Personalization Page</b>
<u>My Applicant Lists Pagelet</u> (HRS_PE_APPL_LISTS)	Lists active public applicant lists and active private applicant lists where the user is the list owner.	Use the <u>Personalize My Applicant Lists Page</u> (HRS_PE_OPR_APPLST) to choose whether to include public lists, private lists, or both on the My Applicant Lists pagelet.
<u>Today's Interviews Pagelet</u> (HRS_PE_INTVW_SCHED)	Lists the user's interviews for the current day.	None
<u>Time to Fill Pagelet</u> (HRS_PE_FILL_CHART)	Provides a bar graph showing the user's average number of days to fill a job opening for a specified time period.	Use the <u>Personalize Time to Fill Page</u> (HRS_PE_OPR_FLCT) to choose the time period to include in the chart
<u>Browse Job Openings Pagelet</u> (HRS_PE_BROWSE_JO)	Provides a keyword search for job openings. Performing the search transfers the user to the Browse Job Openings page.	None
<u>Browse Applicants Pagelet</u> (HRS_PE_BROWSE_APPL)	Provides a keyword search for applicants. Performing the search transfers the user to the Browse Applicants page.	None
<u>Diversity Analytics Pagelet</u> (HRS_PE_DIV_ANA)	Access charts with recruiting diversity analytics.	None

**Note:** The Recruiting Manager Summary Pagelet is also available on the Recruiting Home. It is not shown by default, but users with the Recruiting Manager role can personalize the Recruiting Home to include this pagelet.

## Quick Links Pagelet

Use the Quick Links pagelet (HRS\_QUICK\_LINKS) to easily access the most commonly used recruiting components

This example illustrates the Quick Links pagelet.

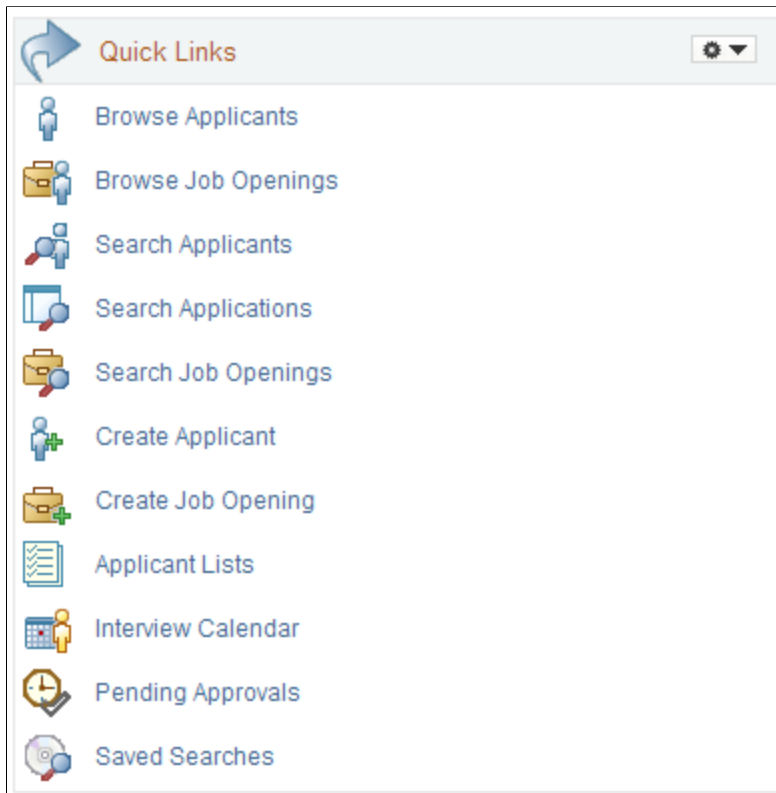

<b>Field or Control</b>	<b>Description</b>
<b>Browse Applicants</b>	Click to access the <a href="#">Browse Applicants Page</a> .
<b>Browse Job Openings</b>	Click to access the <a href="#">Browse Job Openings Page</a> .
<b>Search Applicants</b>	Click to access the Search Applicants page. This page offers four searching option: <ul style="list-style-type: none"> <li>• <a href="#">Search Applicants Page: Quick Search Tab</a></li> <li>• <a href="#">Search Applicants Page: Keyword Search Tab</a></li> <li>• <a href="#">Search Applicants Page: Advanced Search Tab</a></li> <li>• <a href="#">Search Applicants Page: Profile Match Tab</a></li> </ul>
<b>Search Applications</b>	Click to access the <a href="#">Search Applications Page</a> .
<b>Search Job Openings</b>	Click to access the <a href="#">Search Job Openings Page</a> .
<b>Create Applicant</b>	Click to access the <a href="#">Create Applicant Page</a> .
<b>Create Job Opening</b>	Click to access the <a href="#">Primary Job Opening Information Page</a> , where you begin the process of creating a job opening.

<b>Field or Control</b>	<b>Description</b>
<b>Applicant Lists</b>	Click to access the <a href="#">Applicant Lists Page</a> .
<b>Interview Calendar</b>	Click to access the <a href="#">Interview Calendar Page</a> , where you can review your personal interview calendar.
<b>Pending Approvals</b>	Click to access the <a href="#">Pending Approvals Page</a> .
<b>Saved Searches</b>	Click to access the <a href="#">Saved Searches Page</a> .

## My Alerts Pagelet

Use the My Alerts pagelet (HRS\_PE\_ALHRSTS) to view summary information for your own job openings and to access pages with more detailed information.

This example illustrates the My Alerts pagelet.

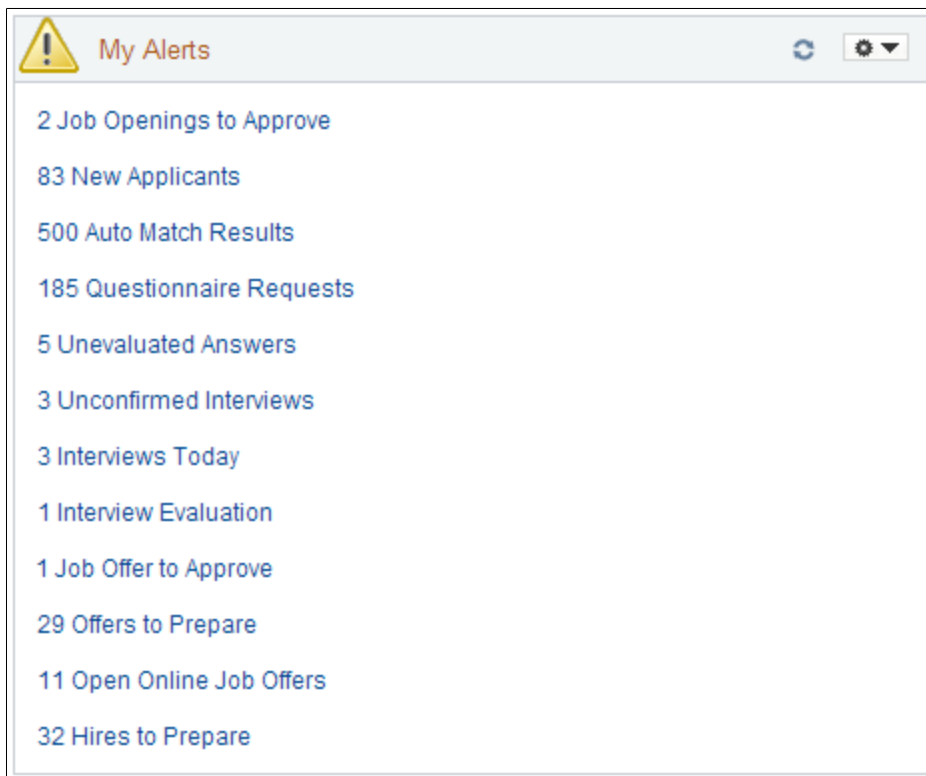



---

**Note:** The alerts displayed on the My Alerts pagelet relate only to the user's own job openings. These are job openings where the user is on the hiring team.

---

## Personalization

<i>Field or Control</i>	<i>Description</i>
	Click the Pagelet Settings icon, then select the <i>Personalize</i> option to access the Personalize My Alerts page, where you can choose which alerts to display and other personalizations.

## Alerts

Each alert label includes both the number and type of alerts. Clicking the alert label opens a page that lists the individual instances.

---

**Note:** Even if the pagelet personalization settings are configured to show a particular alert, the alert does not appear if there are zero instances of the alert.

---

The following table lists the alerts that appear on this pagelet and explains what the number represents. The last column in the table identifies the detail page that appears if you click the alert. Many of the alerts show commonly used recruiting pages (for example, the Search Applicants page), but some detail are used only to support the My Alerts pagelet.

See [Viewing Detail Pages for the My Alerts Pagelet](#).

<i>Alert Label</i>	<i>Description</i>	<i>Page Accessed</i>
<number of> Job Openings to Approve	<p>Displays the number of job openings waiting for the user's approval.</p> <p>If approval authority is delegated to a proxy who has access to the My Alerts pagelet, the delegated transactions are included in the proxy's count (and not the delegator's count) during the delegation period.</p>	<p><a href="#">Pending Approvals Page</a></p> <p>Use this page to review and act on the job openings that require your approval.</p>

<b>Alert Label</b>	<b>Description</b>	<b>Page Accessed</b>
<b>&lt;number of&gt; Job Postings</b>	<p>If you use the Open Integration Framework to post jobs to third-party job boards, this alert displays the number of third-party job postings with these posting statuses: <i>Unconfirmed Post</i>, <i>Unconfirmed Unpost</i>, <i>Awaiting Post</i>, or <i>Posted Error</i>.</p> <p>(This is all postings other than those with the <i>New</i> or <i>Unposted</i> statuses).</p> <hr/> <p><b>Note:</b> This alert is available only for non-US Federal installations with at least one active job board vendor.</p> <hr/>	<p><a href="#">Manage External Postings Page</a></p> <p>Use this page to post, update, and unpost external job postings.</p>
<b>&lt;number of&gt; New Applicants</b>	<p>Displays the number of new applicants that have applied to your job openings within the number of days specified on the Personalize My Alerts page.</p>	<p><a href="#">Search Applicants Page: Quick Search Tab</a></p> <p>When you access the Search Applicants page from this link, it displays the applicants who have applied within the selected time frame.</p>
<b>&lt;number of&gt; Auto Match Results</b>	<p>Displays the number of applicants in the search results for the user’s saved Automatch searches. Search results exist only after the Run Automatch Search (HRS_AM) process has processed the automatch search.</p> <p>See <a href="#">Working With Saved Searches</a></p>	<p><a href="#">Saved Searches Page</a></p> <p>Use this page to view saved automatch searches and to access the associated search results.</p>
<b>&lt;number of&gt; Questionnaire Requests</b>	<p>Displays the number of applicants who have not yet submitted updated applications for job openings with questionnaires after being invited to do so.</p> <p>Only applicants who are linked to currently open job openings are included.</p> <p>See <a href="#">Linking Applicants to Job Openings</a></p>	<p><a href="#">Questionnaire Requests Page</a></p> <p>Use this page to review open questionnaire requests and to send email reminders to selected applicants.</p>

<b><i>Alert Label</i></b>	<b><i>Description</i></b>	<b><i>Page Accessed</i></b>
<b>&lt;number of&gt; Unevaluated Answers</b>	Displays the number of open-ended screening question evaluations that have not been completed for the user's job openings.	<a href="#"><u>Unevaluated Answers Page</u></a> Use this page to see the applicants, job openings, and evaluators for the incomplete evaluations.
<b>&lt;number of&gt; Unconfirmed Interviews</b>	Displays the number of unconfirmed interviews where the user is an interviewer.	<a href="#"><u>Unconfirmed Interviews Page</u></a> Use this page to see the list of unconfirmed interviews.
<b>&lt;number of&gt; Interviews Today</b>	Displays the number of interviews scheduled for the user on that specific day.	<a href="#"><u>Interview Calendar Page</u></a> Use this page to review your weekly interview schedule.
<b>&lt;number of&gt; Interview Evaluations</b>	Displays the number of incomplete interview evaluations where the user is the evaluator. Two types of evaluations are included in the count: <ul style="list-style-type: none"> <li>• Evaluations that were saved as draft but not submitted.</li> <li>• Evaluations that have not been started for an interview that has already occurred (based on the interview date).</li> </ul>	<a href="#"><u>Interview Evaluations Page</u></a> Use this page to review and act on the incomplete evaluations.
<b>&lt;number of&gt; Job Offers to Approve</b>	Displays the number of job offers waiting for the user's approval.  If approval authority is delegated to a proxy who has access to the My Alerts pagelet, the delegated transactions are included in the proxy's count (and not the delegator's count) during the delegation period.	<a href="#"><u>Pending Approvals Page</u></a> Use this page to review and act on the job offers that require your approval.

<b><i>Alert Label</i></b>	<b><i>Description</i></b>	<b><i>Page Accessed</i></b>
<b>&lt;number of&gt; Offers to Prepare</b>	<p>Displays the number of applications that:</p> <ul style="list-style-type: none"> <li>• Have a draft (unsubmitted) offer.</li> <li>• Are in the Interview phase with an Interview status that is the designated “complete” status. As delivered, the complete status for interviews is <i>020 Make Offer</i>.</li> <li>• Are in the Offer phase, but no offer record exists. This occurs only when a user manually changes an applicant’s disposition using the Edit Disposition action.</li> </ul>	<p><a href="#">Offers to Prepare Page</a></p> <p>Use this page to review applicants who are waiting for offers and to access the applicant or job opening so that you can begin preparing the offer.</p>
<b>&lt;number of&gt; Open Online Job Offers</b>	<p>Displays the number of expired or soon-to-expire open online job offers for your job openings. The number includes offers that will expire within the number of days that you specify on the Personalize My Alerts page.</p> <p>Open online job offers are offers that you posted to Candidate Gateway that have not been accepted or rejected. The offer status must be <i>Extend</i>.</p>	<p><a href="#">Open Online Job Offers Page</a></p> <p>Use this page to review the applicants and job openings associated with the open online job offers</p>
<b>&lt;number of&gt; Hires to Prepare</b>	<p>Displays the number of applicants with an <i>Offer Accepted</i> disposition for the user’s job openings.</p>	<p><a href="#">Search Applications Page</a></p> <p>When you access the Search Applications page from this link, it displays applications with the disposition <i>Offer Accepted</i>.</p>

## Personalize My Alerts Page

Use the Personalize My Alerts page (HRS\_PE\_OPR\_ALERT) to choose which alerts to include on the My Alerts pagelet and to provide additional filtering criteria for certain alerts.

This example illustrates the Personalize My Alerts page.

### Personalize My Alerts

Specify the type of alerts you would like to see on your pagelet.

**Display Preferences**

- Job Openings to Approve
- New Applicants \*Applied Within
- Auto Match Results
- Questionnaire Requests
- Unevaluated Answers
- Unconfirmed Interviews
- Interviews Today
- Interview Evaluations
- Job Offers to Approve
- Job Offers in Progress
- Open Online Job Offers Days Until Offer Expires
- Hires to Prepare

**Note:** An additional check box for the Job Postings alert appears in non-US Federal implementations that have at least one active job board vendor.

<b>Field or Control</b>	<b>Description</b>
<b>&lt;Alert Name&gt;</b>	Select the check boxes for the alerts that you want to display on the My Alerts pagelet.
<b>Applied Within</b>	The New Applicants alert displays the number of applications that were submitted within the time period you select here. Options include <i>Today, Yesterday, Last 3 Days, Last Week, Last 2 Weeks, Last Month, Last Year, and View All.</i>
<b>Days Until Offer Expires</b>	The Open Online Job Offers alert displays the number of open online job offers that will expire within the number of days that you enter here.

## My Job Openings Pagelet

Use the My Job Openings pagelet (HRS\_PE\_MY\_JOBS) to view jobs openings to which you have access. You can review key information about each job opening and access job opening analytics.



This example illustrates the My Job Openings pagelet.

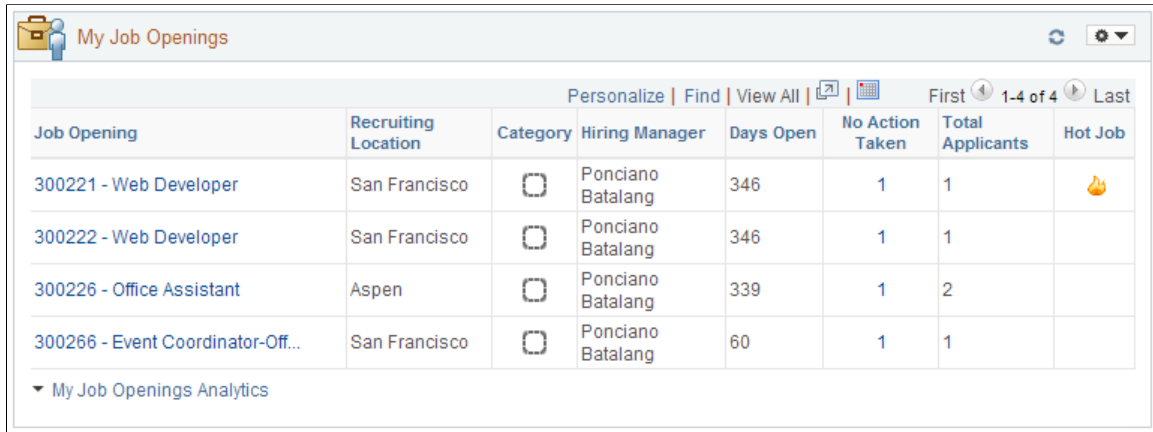

### Personalization

Field or Control	Description
	Click the Pagelet Settings icon, then select the <i>Personalize</i> option to access the Personalize My Job Openings page, where you can choose which job openings to display.

### Job Openings Grid

**Note:** The number of rows in the My Job Openings grid is limited based on the value entered in the **My Job Openings Pagelet Maximum Results** field on the **Recruiting Installation – Jobs Page**.

Field or Control	Description
<b>Job Opening</b>	Displays the Job Opening ID and the job opening’s primary posting title. Click this link to access the Manage Job Opening page.
<b>Recruiting Location</b>	Displays the primary recruiting location for the job opening.
<b>Category</b>	<p>If job categorization is enabled on the <b>Recruiting Installation – Jobs Page</b>, this column enables you to view and change the category for the job opening. Categories are a personal organizational tool, and your categorization is not visible to other users.</p> <p>To change a job’s category, click the Category icon to open the <b>My Job Categories Page</b>, where you can select either a new category or no category.</p>

<b>Field or Control</b>	<b>Description</b>
<b>Hiring Manager or Recruiter</b>	<p>This column displays either the job opening's primary hiring manager or the job opening's primary recruiter, depending on the roles assigned to the current user:</p> <ul style="list-style-type: none"> <li>• If the user has a <i>Recruiter</i>, <i>Recruiting Manager</i>, or <i>Recruitment Administrator</i> role, the Hiring Manager column appears.</li> <li>• If the user has a <i>Hiring Manager</i> role (and not any of the other roles listed), the Recruiter column appears.</li> </ul>
<b>Days Open</b>	<p>For job openings in an open status, this column displays the number of days since the job opening's earliest posting date. If the job has never been posted, this field displays the number of days since the job opening was created. If the earliest job posting date (or, if none, the job creation date) is in the future, the system displays 0.</p>
<b>Days to Fill Date</b>	<p>Displays the number of days remaining until the projected fill date. This column is hidden entirely if none of the job openings have a projected fill date or are in an open status.</p>
<b>No Action Taken</b>	<p>Displays the number of applicants in the Applied phase. Click this number to access the Manage Job Opening page pre-filtered to show only applicants in this phase.</p>
<b>Total Applicants</b>	<p>Displays the total number of applicants that have applied for the job. Applicants with multiple applications are counted only once, and draft applications are not considered.</p>
 <b>Hot Job</b>	<p>Displays the hot job icon for any jobs that are hot jobs. This column is hidden entirely if none of the job openings are hot jobs.</p>

## Additional Job Opening Data

The Job Openings grid includes additional columns that are delivered hidden. To display these additional columns, use PeopleTools Application Designer to modify the grid definition.

The additional hidden columns are:

- Job Opening Type
- Target Openings
- Department

- Status
- Desired Start Date
- Earliest Post Date
- Unpost Date
- Latest Post Date
- Projected Fill Date

**Note:** If all job openings shown in the My Job Openings pagelet are continuous job openings, the Desired Start Date and Projected Fill Date columns are hidden even if you have modified the grid definition to show these columns.

### My Job Opening Analytics

<i>Field or Control</i>	<i>Description</i>
<b>My Job Opening Analytics</b>	Click to display a menu listing relevant pivot grids, then select one of the following pivot grids to display: <ul style="list-style-type: none"> <li>• Job Opening Aging Analysis See <a href="#">Job Opening Aging Analysis Pivot Grid</a></li> <li>• Job Opening Open and Close Trend See <a href="#">Job Opening Open and Close Trend Pivot Grid</a></li> </ul>

### Personalize My Job Openings Page

Use the Personalize My Job Openings page (HRS\_PE\_OPR\_MYJOBS) to set filter options to control which job openings appear on the My Job Openings pagelet.

This example illustrates the Personalize My Job Openings pagelet.

#### Personalize My Job Openings

Select the filter options that determine which Job Openings display on the pagelet.

**Filter Options**

\*Display

\*Status

\*Created Within

<b>Field or Control</b>	<b>Description</b>
<b>Display</b>	<p>Select a value to filter pagelet data according to your relationship with the job opening.</p> <p><i>Jobs Associated with me</i> are job openings that you created or where you are part of the hiring team. <i>Jobs Assigned to me</i> (the default value) is a subset of the jobs associated with you; it includes only job openings where you are either the primary recruiter or the primary hiring manager. The other filtering options are <i>Jobs Created by me</i> and <i>All Jobs</i>.</p> <p>When users are subject to enhanced applicant security, the <i>All Jobs</i> option would show the same jobs as the <i>Jobs Associated with me</i> option. Therefore, users who are subject to enhanced applicant security do not see the <i>All Jobs</i> option.</p> <p>See <a href="#">Understanding Enhanced Applicant Security</a>.</p>
<b>Status</b>	Select a value to filter pagelet data based on the job openings status. The default value is <i>Open</i> .
<b>Created Within</b>	Select a value to filter pagelet data based on how recently the job opening was created. Options include <i>Today Yesterday</i> , <i>Last 3 Days</i> , <i>Last Week</i> , <i>Last 2 Weeks</i> , <i>Last Month</i> , <i>Last Year</i> (the default value) and <i>View All</i> .

## My Applicants Pagelet

Use the My Applicants pagelet (HRS\_PE\_MY\_APPS) to view applicants who are associated with your job openings, to review key information about each applicant, and to access applicant analytics.

This example illustrates the My Applicants pagelet.

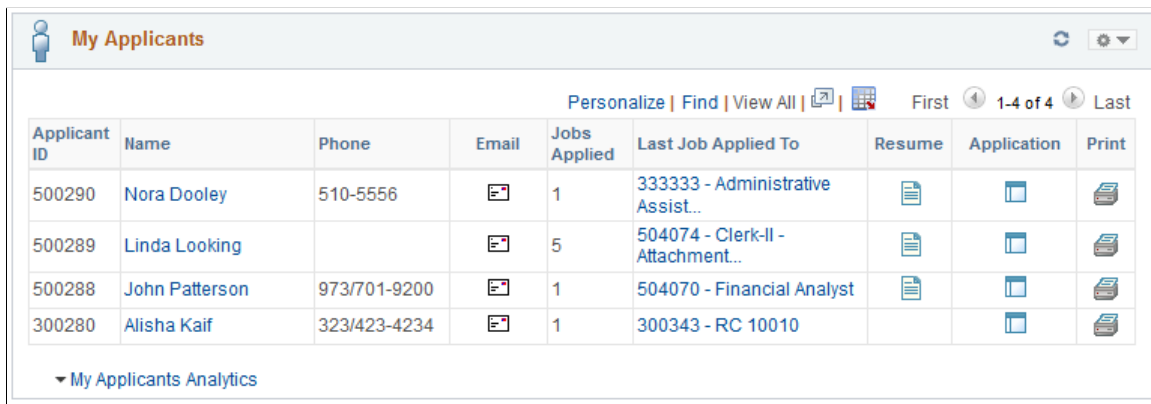

My Applicants								
Applicant ID	Name	Phone	Email	Jobs Applied	Last Job Applied To	Resume	Application	Print
500290	Nora Dooley	510-5556		1	333333 - Administrative Assist...			
500289	Linda Looking			5	504074 - Clerk-II - Attachment...			
500288	John Patterson	973/701-9200		1	504070 - Financial Analyst			
300280	Alisha Kaif	323/423-4234		1	300343 - RC 10010			

▼ My Applicants Analytics

## Included Applicants

The My Applicants pagelet lists applicants who:

- Are associated with the user's job openings (openings to which the user has security access).

- Are not in a Draft disposition (the disposition marked as Draft in your status configuration).
- Are not in a Reject disposition (any disposition associated with the Reject phase).

A pagelet personalization option provides the additional ability to filter based on how recently the application was received.

---

**Note:** The number of rows in the Applicants grid is limited based on the value entered in the **My Applicants Pagelet Maximum Results** field on the [Recruiting Installation – Applicants Page](#).



---

## Personalization

<i>Field or Control</i>	<i>Description</i>
	Click the Pagelet Settings icon, then select the <i>Personalize</i> option to access the Personalize My Applicants page, where you can choose to filter applicants based on how recently the application was received.

## Applicants Grid

<i>Field or Control</i>	<i>Description</i>
<b>Applicant ID and Name</b>	These fields display identifying information about the applicant. Click the applicant's name to access the Manage Applicant page.
<b>Phone</b>	Displays the applicant's primary phone number, if one exists.
 <b>Email</b>	<p>The Email icon appears if the applicant record includes a primary email address. The system displays the actual email address as mouseover text for the icon.</p> <p>Click the icon to access the <a href="#">Send Correspondence Page</a> to send email (or a letter) to the applicant. If a user does not have authorization for the Send Correspondence component, the user's default email client is opened instead.</p>

<b>Field or Control</b>	<b>Description</b>
<b>Jobs Applied</b>	<p>Displays the number of jobs for which the applicant has applications.</p> <p>All job openings are included, even if they are closed or if the user does not have security access to the opening. If the applicant applied more than once to the same job opening, that opening is counted only once.</p> <p>Applications not linked to a job opening are not included in the count, nor are unsubmitted (draft) applications</p>
<b>Last Job Applied To</b>	<p>Displays the job opening ID and title for the applicant's most recent application. Click the link to access the Manage Job Opening page.</p>
 <b>Resume</b>	<p>The Resume icon appears if the most recent application includes a resume. Click the icon to open the resume in a new window. If the resume is an attachment, the file opens in the new window. If the resume was entered as text in the application, the new window displays the Applicant Resume page in read-only mode.</p> <p>If none of the listed applicants have resumes, this column is hidden.</p>
 <b>Application</b>	<p>Displays the Manage Application icon. Click the icon to access the Manage Application page, which provides a central location for performing all recruiting activities for a single job application.</p>
 <b>Print</b>	<p>Click to access the <a href="#">Application Report Options Page</a>, where you can choose report parameters and then generate an application details report.</p>

## Additional Applicant Data

The Applicants grid includes additional columns that are delivered hidden. To display these additional columns, use PeopleTools Application Designer to modify the grid definition.

The additional hidden columns are:

- Applicant Type
- Preferred Contact Method

## My Applicants Analytics

<i>Field or Control</i>	<i>Description</i>
<b>My Applicants Analytics</b>	<p>Click to display a menu listing related pivot grids. The menu includes a single item: In Process Applicants. Click this menu item to open the pivot grid.</p> <p>See <a href="#">In Process Applicants Pivot Grid</a>.</p>

## Personalize My Applicants Page

Use the Personalize My Applicants page (HRS\_PE\_OPR\_MYAPPS) to set filter options to control which applicants appear on the My Applicants pagelet.

This example illustrates the Personalize My Applicants page.

<i>Field or Control</i>	<i>Description</i>
<b>Applied Within</b>	<p>Select a value to filter pagelet data based on how recently the most recent application was received. Options include <i>Today</i>, <i>Yesterday</i>, <i>Last 3 Days</i>, <i>Last Week</i>, <i>Last 2 Weeks</i>, <i>Last Month</i> (the default setting), <i>Last Year</i>, and <i>View All</i>.</p>

## My Applicant Lists Pagelet

Use the My Applicant Lists pagelet (HRS\_PE\_APPL\_LISTS) to view your active applicant lists.

This example illustrates the My Applicant Lists pagelet.

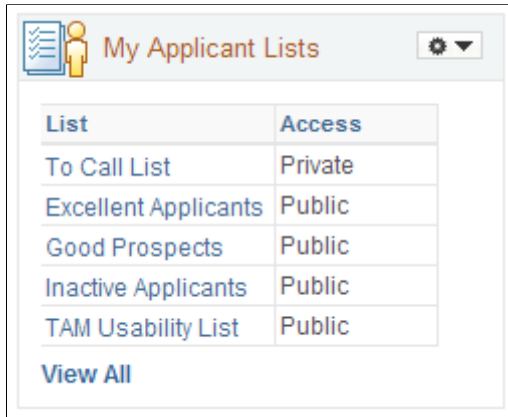

This pagelet displays a list of active applicant lists that are either public or, if private, that are owned by the current user. The list shows a maximum of five lists: first the user's private lists appear alphabetically, then the public lists appear alphabetically.

<b>Field or Control</b>	<b>Description</b>
<b>List</b>	Displays the list name. Click the name to access the <a href="#">Manage Applicant List Page</a> .
<b>Access</b>	Indicates whether the list is <i>Private</i> or <i>Public</i> .
<b>View All</b>	Click to access the <a href="#">Applicant Lists Page</a> , which displays all of the user's lists (along with other user's public lists).

## Personalize My Applicant Lists Page

Use the Personalize My Applicant Lists page (HRS\_PE\_OPR\_MYAPPS) to choose whether to include public lists, private lists, or both on the My Applicant Lists pagelet.

This example illustrates the Personalize My Applicant Lists page.

**Personalize My Applicant Lists**

Specify the types of applicant lists to display on your pagelet.

**Filter Options**

Include Public Lists

Include Private Lists

---

**Note:** At least one of the check boxes on this page must be selected.

---



<b>Field or Control</b>	<b>Description</b>
<b>Include Public Lists</b>	Select this check box to include public lists on the My Applicant Lists pagelet.
<b>Include Private Lists</b>	Select this check box to include private lists on the My Applicant Lists pagelet.

## Today’s Interviews Pagelet

Use the Today’s Interviews pagelet (HRS\_PE\_INTVW\_SCHED) to view your interviews for the current day.

This example illustrates the Today’s Interviews pagelet.

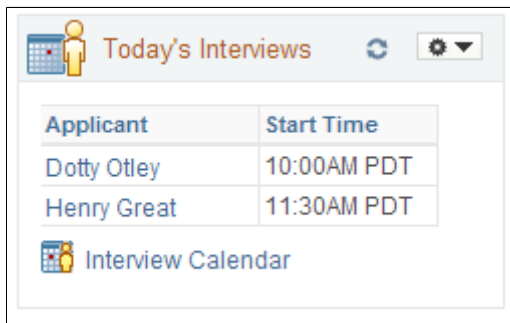

The Today’s Interviews pagelet displays interviews that the user is scheduled to participate in today. Cancelled interviews are not listed.

<b>Field or Control</b>	<b>Description</b>
<b>Applicant</b>	Displays the name of the applicant to be interviewed. Click the name to access the Manage Applicant page.
<b>Start Time</b>	Displays the interview start time in the user’s preferred time zone and display format as identified on the My Personalizations page.
<b>Interview Calendar</b>	Click to access the <a href="#">Interview Calendar Page</a> , which displays the user’s complete interview calendar.

## Time to Fill Pagelet

Use the Time to Fill pagelet (HRS\_PE\_FILL\_CHART) to see data related to how long it takes you to fill job openings after the job is posted.

This example illustrates the Time to Fill pagelet.

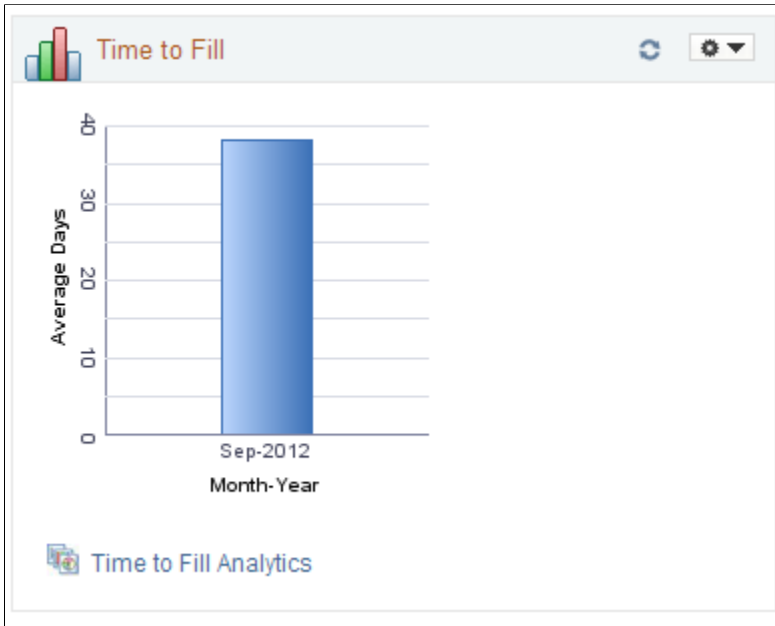

<b>Field or Control</b>	<b>Description</b>
<p>&lt;Bar Graph&gt;</p>	<p>Displays monthly average Time to Fill data for job openings where the user is either a recruiter or a hiring manager. Each bar represents the average Time to Fill for all job openings that were filled in the specified month. The pagelet’s personalization options control the time period covered by the graph. The initial default time period is the three months ending today.</p> <p>A job opening’s Time to Fill is the number of days between the earliest post date for the opening and the date when the job opening status changes to <i>110 - Filled/Closed</i>. If the job opening was never posted, then Time to Fill is measured from the job opening creation date.</p> <p>Continuous job openings and job openings where the <b>Openings to Fill</b> value is <i>Unlimited Number of Openings</i> are never filled and therefore are not included in the Time to Fill calculation.</p> <p>Clicking the bar for a particular month opens the Pivot Grid Drilldown page, which lists the job openings that were filled that month and shows the Time to Fill for each opening.</p> <hr/> <p><b>Note:</b> Users who view this page in screen reader mode are presented with a grid rather than a bar graph. The grid includes a column for the month and a column for the corresponding average Time to Fill.</p> <hr/>

<i>Field or Control</i>	<i>Description</i>
<b>Time to Fill Analytics</b>	Click to display a menu listing related pivot grids. The menu includes a single item: Time to Fill. Click this menu item to open the pivot grid.  See <a href="#">Time to Fill Pivot Grid</a> .

## Personalize Time to Fill Page

Use the Personalize Time to Fill page (HRS\_PE\_OPR\_FLCT) to choose the time period to include in the chart on the Time to Fill pagelet.

This example illustrates the Personalize Time to Fill page.

<i>Field or Control</i>	<i>Description</i>
<b>Date Filled/Closed From and Date Filled/Closed To</b>	Specify the time period to include in the Time to Fill chart. Job openings that were closed within the specified time period are included in the data.  Note that the bars on the chart still show calendar months, even if you do not include the full month in the time period. For example, if the <b>Date Filled/Closed From</b> field is May 15, then the first bar on the Time to Fill chart is for May, even though the data represents only job openings that were filled or closed after May 15.

## Browse Job Openings Pagelet

Use the Browse Job Openings pagelet (HRS\_PE\_BROWSE\_JO) to perform a keyword search for job openings. Performing the search transfers you to the Browse Job Openings page.

This example illustrates the Browse Job Openings pagelet.

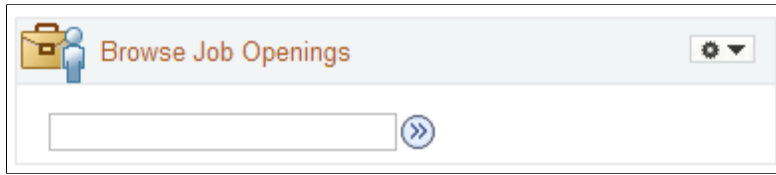



<b>Field or Control</b>	<b>Description</b>
 Search	After entering your search keyword in the adjacent field, click the Search icon to perform the search and display the results on the Browse Job Openings page.

## Browse Applicants Pagelet

Use the Browse Applicants pagelet (HRS\_PE\_BROWSE\_APPL) to perform a keyword search for applicants. Performing the search transfers you to the Browse Applicants page.

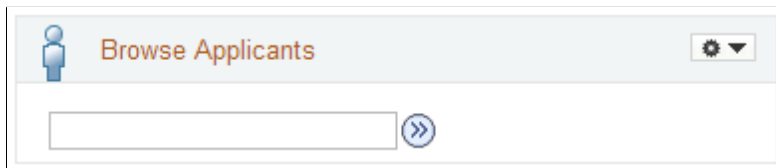
This example illustrates the Browse Applicants pagelet.



<b>Field or Control</b>	<b>Description</b>
 Search	After entering your search keyword in the adjacent field, click the Search icon to perform the search and display the results on the Browse Applicants page.

## Diversity Analytics Pagelet

Use the Diversity Analytics pagelet (HRS\_PE\_DIV\_ANA) to access charts with recruiting diversity analytics.

This example illustrates the Diversity Analytics pagelet.

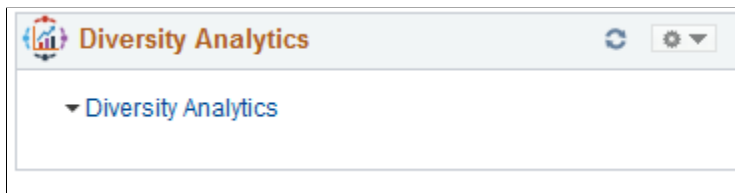

<i>Field or Control</i>	<i>Description</i>
<b>Diversity Analytics</b>	<p>Click this link to access a related actions menu, which includes two menu items:</p> <p>Click the <b>Applicant Diversity Overview</b> menu item to access the <a href="#">Applicant Diversity Overview Pivot Grid</a>.</p> <p>Click the <b>Diversity by Applications</b> menu item to access the <a href="#">Diversity By Applications Pivot Grid</a>.</p>

## Viewing Detail Pages for the My Alerts Pagelet

The My Alerts pagelet on the Recruiting Home page consolidates a variety of important information for recruiters. From the pagelet, you can access detail pages with additional information.

The documentation for the [My Alerts Pagelet](#) lists the target pages for all of the alert links and provides links to the related documentation. Many of these target pages are commonly used recruiting page such as the Search Applicants page or the Pending Approvals page, while others are accessible only from the My Alerts pagelet.

This topic describes the pages that are accessible only from the My Alerts pagelet.

## Pages Accessed Exclusively from the My Alerts Pagelet

<i>Page Name</i>	<i>Definition Name</i>	<i>Usage</i>
<a href="#">Questionnaire Requests Page</a>	HRS_PSNAPFOR_LST	<p>View details for the <b>Questionnaire Requests</b> alert.</p> <p>Review applicants who have not completed an online questionnaire after being linked to one of the user's currently open job openings.</p>
<a href="#">Unevaluated Answers Page</a>	HRS_UNEVAL_ANS	<p>View details for the <b>Unevaluated Answers</b> alert.</p> <p>Review applicants whose answers to open-ended questions have not yet been evaluated; send reminders to the evaluators.</p>
<a href="#">Unconfirmed Interviews Page</a>	HRS_UNC_INT_SUM	<p>View details for the <b>Unconfirmed Interviews</b> alert.</p> <p>Review applicants where you are an interviewer for an unconfirmed interview.</p>

<b>Page Name</b>	<b>Definition Name</b>	<b>Usage</b>
<u>Interview Evaluations Page</u>	HRS_EVAL_SUMM	View details for the <b>Interview Evaluations</b> alert.  Review applicants whose interview evaluations you need to complete.
<u>Offers to Prepare Page</u>	HRS_PSNAPPFOR_LIST	View details for the <b>Offers to Prepare</b> alert.  Review applicants who need to have an offer prepared.
<u>Open Online Job Offers Page</u>	HRS_OFFER_OJO_LIST	View details for the <b>Open Online Job Offers</b> alert.  Review applicants with soon-to-expire online job offers.

## Questionnaire Requests Page

Use the Questionnaire Request page (HRS\_PSNAPPFOR\_LST) to review a list of applicants who have not completed an online questionnaire after being linked to one of the user's currently open job openings and after being sent a request to complete the questionnaire.

Navigation:

Click the **Questionnaire Requests** link on the My Alerts Pagelet

This example illustrates the Questionnaire Request page.

### Questionnaire Requests

🏠 [Recruiting Home](#)

Listed below are the applicants who have not completed the questionnaires for your job openings. Choose **Send Reminder** to send email to selected applicants to remind them to complete answers to the questionnaires.

Applicants	Personalize	View 100	First	1-10 of 185	Last
Select	Applicant	Applicant ID	Job Opening	Posting Title	
<input type="checkbox"/>	ABELIE CLIVE	300084	300090	Guest Services Manager	
<input type="checkbox"/>	Aba Azikiwe	300197	300259	Store Manager	
<input type="checkbox"/>	Aba Azikiwe	300197	300264	Store Manager	
<input type="checkbox"/>	Aba Azikiwe	300197	300256	Store Manager	
<input type="checkbox"/>	Aba Azikiwe	300197	300257	Store Manager	
<input type="checkbox"/>	Aba Azikiwe	300197	300258	Store Manager	
<input type="checkbox"/>	Aba Azikiwe	300197	300260	Store Manager	
<input type="checkbox"/>	Aba Azikiwe	300197	300255	Store Manager	
<input type="checkbox"/>	Aba Azikiwe	300197	300261	Store Manager	
<input type="checkbox"/>	Aba Azikiwe	300197	300262	Store Manager	

Select All Deselect All

Send Reminder

<b>Field or Control</b>	<b>Description</b>
<b>Select</b>	Use the <b>Select</b> check box to choose which applicants to include when you click the <b>Send Reminder</b> button.
<b>Applicant and Applicant ID</b>	These fields display identifying information about the applicant. Click the applicant name to access the Manage Applicant page.
<b>Job Opening and Posting Title</b>	<p>These fields display identifying information about the job opening that the applicant was asked to reapply for. Click the job opening ID to access the Manage Job Opening page.</p> <hr/> <p><b>Note:</b> Only job openings with a current status of <i>Open</i> are included in this alert. When the job opening is closed, there is no longer any reason to remind the applicant to submit an application, so the alert disappears from the list.</p>
<b>Send Reminder</b>	Click the <b>Send Reminder</b> button to send the selected applicants a new invitation to apply for the selected job opening.

## Unevaluated Answers Page

Use the Unevaluated Answers page (HRS\_UNEVAL\_ANS) to review a list of applicants whose answers to open-ended questions have not yet been evaluated and to send reminders to the evaluators.

Navigation:

Click the **Unevaluated Answers** link on the [My Alerts Pagelet](#)

This example illustrates the Unevaluated Answers page.

### Unevaluated Answers

[Home](#) Recruiting Home

Select rows to send reminder email to the evaluator or to remove the evaluator from the job opening, then choose the appropriate action button.

Applicants with Unevaluated Answers						Personalize   Find
Select	Applicant	Job Opening	Question ID	Date Applied	Evaluator	First  1-5 of 5  Last
<input type="checkbox"/>	<a href="#">Deepak Patel</a>	300089	1029	02/06/2009 7:14AM	Jacob Taylor	
<input type="checkbox"/>	<a href="#">Francis Quinn</a>	503705	1034	08/06/2009 6:00PM	Betty Locherty	
<input type="checkbox"/>	<a href="#">Renfrew Dhelson</a>	503709	1105	08/04/2009 9:49PM	Betty Locherty	
<input type="checkbox"/>	<a href="#">Orclear Peasel</a>	503709	1105	08/04/2009 9:57PM	Betty Locherty	
<input type="checkbox"/>	<a href="#">Dotty Otley</a>	504022	1034	09/04/2012 4:43PM	Betty Locherty	

[Select All](#)   [Deselect All](#)

Send Reminder
Delete Request

<b>Field or Control</b>	<b>Description</b>
<b>Select</b>	Use the <b>Select</b> check box to choose which applicants to include when you click the <b>Send Reminder</b> or <b>Delete Request</b> button.
<b>Applicant</b>	Displays the name of the applicant whose answer has not yet been evaluated. Click this link to access the Manage Applicant page.
<b>Job Opening</b>	Displays the job opening with the question whose answer has not yet been evaluated. Click this link to access the Manage Job Opening page.
<b>Question ID</b>	Displays the unique identifier for the question whose answer has not yet been evaluated.
<b>Date Applied</b>	Displays the date that the applicant applied for the job opening.



<i>Field or Control</i>	<i>Description</i>
<b>Evaluator</b>	Displays the name of the evaluator who has not yet evaluated the applicant’s answer.

### Buttons for Managing Unevaluated Answers

<i>Field or Control</i>	<i>Description</i>
<b>Send Reminder</b>	Select the check box next to one or more of the applicants in the grid, then click the <b>Send Reminder</b> button to send a reminder to the evaluators who are assigned to evaluate answers for the selected applicants.
<b>Delete Request</b>	Select the check box next to one or more of the applicants in the grid, then click the <b>Delete Request</b> button to remove the selected rows from this grid. Removing rows from this grid does <i>not</i> change anything about the screening process; unevaluated answers are still included in screening. If there are no evaluations for the answer, then the applicant receives no points for the answer.

## Unconfirmed Interviews Page

Use the Unconfirmed Interviews page (HRS\_UNC\_INT\_SUM) to review applicants where you are an interviewer for an unconfirmed interview.

Navigation:

Click the **Unconfirmed Interviews** link on the [My Alerts Pagelet](#)

This example illustrates the Unconfirmed Interviews page.

Unconfirmed Interviews				
<a href="#">Recruiting Home</a>				
Unconfirmed Interviews		<a href="#">Personalize</a>   <a href="#">Find</a>   <a href="#">View All</a>		
		First  1-3 of 3  Last		
Applicant	Applicant ID	Job Opening	Posting Title	Action
Allan Kirschbaum	500263	504001	General Office Clerk	<a href="#">View Interview Schedule</a>
Esmeralda Guerriero	500267	504001	General Office Clerk	<a href="#">View Interview Schedule</a>
Benita Zingaro	500272	504001	General Office Clerk	<a href="#">View Interview Schedule</a>

<b>Field or Control</b>	<b>Description</b>
<b>Applicant and Applicant ID</b>	These fields display identifying information about the applicant to be interviewed.
<b>Job Opening and Posting Title</b>	These fields display identifying information about the job opening for which the applicant is being interviewed.
<b>View Interview Schedule</b>	Click this link to access the Interview Schedule page, where you manage interview schedules.

## Interview Evaluations Page

Use the Interview Evaluations page (HRS\_EVAL\_SUMM) to review applicants whose interview evaluations you need to complete.

Navigation:

Click the **Interview Evaluations** link on the [My Alerts Pagelet](#)

This example illustrates the Interview Evaluations page.

Interview Evaluations				
<a href="#">Recruiting Home</a>				
Interview Evaluations			Personalize   Find   View All	First  1-10 of 18  Last
Applicant	Applicant ID	Job Opening	Posting Title	Action
Juan Cervantes	500006	503708	Bring Your Arbitration Experience to Labor Relations	<a href="#">Complete Evaluation</a>
Sonia Nayar	500041	503708	Bring Your Arbitration Experience to Labor Relations	<a href="#">Complete Evaluation</a>
Darcy Leinen	500269	504004	Executive Services Administrator	<a href="#">Evaluate Applicant</a>
Ramilio Estavias	500007	503708	Bring Your Arbitration Experience to Labor Relations	<a href="#">Evaluate Applicant</a>
Henrietta Bourallee	500008	503708	Bring Your Arbitration Experience to Labor Relations	<a href="#">Evaluate Applicant</a>
Paulo Coelho	500010	503708	Bring Your Arbitration Experience to Labor Relations	<a href="#">Evaluate Applicant</a>
Paulo Coelho	500011	503708	Bring Your Arbitration Experience to Labor Relations	<a href="#">Evaluate Applicant</a>
James Cordeira	500014	503708	Bring Your Arbitration Experience to Labor Relations	<a href="#">Evaluate Applicant</a>
Krishnan Pallash	500038	503708	Bring Your Arbitration Experience to Labor Relations	<a href="#">Evaluate Applicant</a>
Bonita Van Zyl	500044			<a href="#">Evaluate Applicant</a>

Two types of evaluations appear on this page

- Evaluations that were saved as draft but not submitted.
- Evaluations that have not been started for an interview that has already occurred (based on the interview date).

<b>Field or Control</b>	<b>Description</b>
<b>Applicant and Applicant ID</b>	These fields display identifying information about the applicant whose interview evaluation is not yet submitted.
<b>Job Opening and Posting Title</b>	These fields display identifying information about the job opening for which the applicant was interviewed.
<b>Action</b>	<p>Click this link to open the Interview Evaluation page and enter evaluation information.</p> <p>The link text is <i>Complete Evaluation</i> if you previously saved the evaluation as a draft.</p> <p>The link text is <i>Evaluate Applicant</i> if you have not yet started the evaluation.</p>

## Offers to Prepare Page

Use the Offers to Prepare page (HRS\_PSNAPFOR\_LIST) to review a list of applicants who need to have an offer prepared.

Navigation:

Click the **Offers to Prepare** link on the [My Alerts Pagelet](#)

This example illustrates the Offers to Prepare page.

### Offers to Prepare

[Recruiting Home](#)

Listed below are the applicants for your job openings who need to have an offer prepared (includes offers in draft). Select the applicant's name to create or update the existing job offer details.

Applicants		Personalize   View All	First	1-10 of 29	Last
Applicant	Applicant ID	Disposition	Job Opening	Posting Title	
<a href="#">Al Brah</a>	330	Offer	290013	Financial Analyst	
<a href="#">Alex James</a>	300076	Applied	300087	Guest Services Manager AD C	
<a href="#">Angel Lodge</a>	300101	Applied	300110	Event Coordinator AD F	
<a href="#">Bena Orrtha</a>	300120	Applied	300135	Event Coordinator AD C	
<a href="#">Bryan Noah</a>	300075	Applied	300085	Guest Services Manager AD C	
<a href="#">Catherine Philip</a>	300015	Applied	300073	Web Developer AD C	
<a href="#">Christine Flow</a>	300182	Accepted	300175	RC2-Personnel/Administrative Chief	
<a href="#">Clive Seed</a>	300179	Accepted	300175	RC2-Personnel/Administrative Chief	
<a href="#">Dominic Alejandro</a>	300103	Applied	300118	Event Coordinator AD F	
<a href="#">Edmond Miller</a>	300183	Accepted	300175	RC2-Personnel/Administrative Chief	

<b>Field or Control</b>	<b>Description</b>
<b>Applicant and Applicant ID</b>	These fields display identifying information about the applicant who needs to have an offer prepared. Click the applicant name to access the Manage Applicant page where you can initiate the offer process.
<b>Disposition</b>	Displays the applicant's current disposition for the job opening for which the offer is needed.
<b>Job Opening and Posting Title</b>	These fields display identifying information about the job opening for which the applicant was interviewed. Click the job opening ID to access the Manage Job Opening page where you can initiate the offer process.

## Open Online Job Offers Page

Use the Open Online Job Offers page (HRS\_OFFER\_OJO\_LIST) to review a list of applicants with soon-to-expire online job offers.

Navigation:

Click the **Open Online Job Offers** link on the [My Alerts Pagelet](#)

This example illustrates the Open Online Job Offers page.

### Open Online Job Offers

[Recruiting Home](#)

Listed below are the applicants who have received an online job offer for your job openings. Select the applicant's name to view the job offer details.

Applicants <span style="float: right;">Personalize   View All </span>						
Applicant	Applicant ID	Job Opening	Posting Title	Offer Date	Expiration Date	Status
<a href="#">Karla Benerfer</a>	300129	503705	Radiologist - Burns Unit	08/04/2009	08/14/2009	Viewed
<a href="#">Jacqueline Bertholt</a>	300132	503705	Radiologist - Burns Unit	08/04/2009	08/14/2009	Original
<a href="#">David Davies</a>	300137	503705	Radiologist - Burns Unit	08/04/2009	08/14/2009	Viewed
<a href="#">Glen Devere</a>	300141	503705	Radiologist - Burns Unit	08/04/2009	08/14/2009	Original
<a href="#">Eugene Eugeneson</a>	300136	503705	Radiologist - Burns Unit	08/04/2009	08/14/2009	Original
<a href="#">Brian Parkersohn</a>	300131	503705	Radiologist - Burns Unit	08/06/2009	08/16/2009	Original
<a href="#">Francis Quinn</a>	300138	503705	Radiologist - Burns Unit	08/06/2009	08/16/2009	Original
<a href="#">Sharmayne Greerson</a>	300139	503705	Radiologist - Burns Unit	08/06/2009	08/16/2009	Original
<a href="#">Graeme Wood</a>	100286	300002	Web Developer Staff	11/05/2008	11/15/2011	Original
<a href="#">Graeme Wood</a>	100286	300003	Web Developer Specialist	11/05/2008	11/15/2011	Original

<b>Field or Control</b>	<b>Description</b>
<b>Applicant Name and Applicant ID</b>	These fields display identifying information about the applicant with the open online job offer. Click the applicant name to access the offer on the Prepare Job Offer page.
<b>Job Opening and Posting Title</b>	These fields display identifying information about the job opening that is associated with the open offer. Click the job opening ID to access the Manage Job Opening page.
<b>Offer Date</b>	Displays the date that the offer was extended.
<b>Expiration Date</b>	Displays the date that the online offer will expire.
<b>Status</b>	Displays <i>Viewed</i> if the applicant has viewed the online job offer, or displays <i>Original</i> if the applicant has not yet viewed it.

## Viewing the Recruiting Manager Summary Pagelet

This topic discusses the Recruiting Manager summary pagelet. This pagelet lists summary information about the workload and effectiveness of recruiters who report to the current user. It also provides access to recruiting pivot grids that provide actionable operational analytics.

See [Viewing Recruiting Pivot Grids](#).

**Note:** The option to display the **Recruiting Manager Summary** pagelet is visible only to users with the Recruiting Manager role. These users can add the pagelet to the PeopleSoft home page or to the Recruiting Home page.

## Recruiting Manager Summary Pagelet and its Personalization Page

This table provides summary information about the Recruiting Manager Summary pagelet.

<i>Pagelet Name</i>	<i>Description</i>	<i>Personalization Page</i>
<a href="#">Recruiting Manager Summary Pagelet</a> (HRS_PE_MGR_SUMM)	View summary information about the workload and effectiveness of recruiters who report to you. This pagelet shows information for direct reports only, not for the user's entire organization.	Use the <a href="#">Personalize Recruiting Manager Summary Page</a> to choose the time period to include in the recruiting manager metrics and to set filter options to control which types of applicants and job openings are included.

## Recruiting Manager Summary Pagelet

Use the Recruiting Manager Summary pagelet (HRS\_PE\_MGR\_SUMM) to view summary information about the workload and effectiveness of recruiters who report to you. This pagelet shows information for direct reports only, not for the user's entire organization.

**Note:** This pagelet supports up to 300 direct reports. If a user with more than 300 direct reports attempts to use this pagelet, the grid will stop after loading data for 300 direct reports, and the system will display a message to the user.

This example illustrates the Recruiting Manager Summary pagelet.

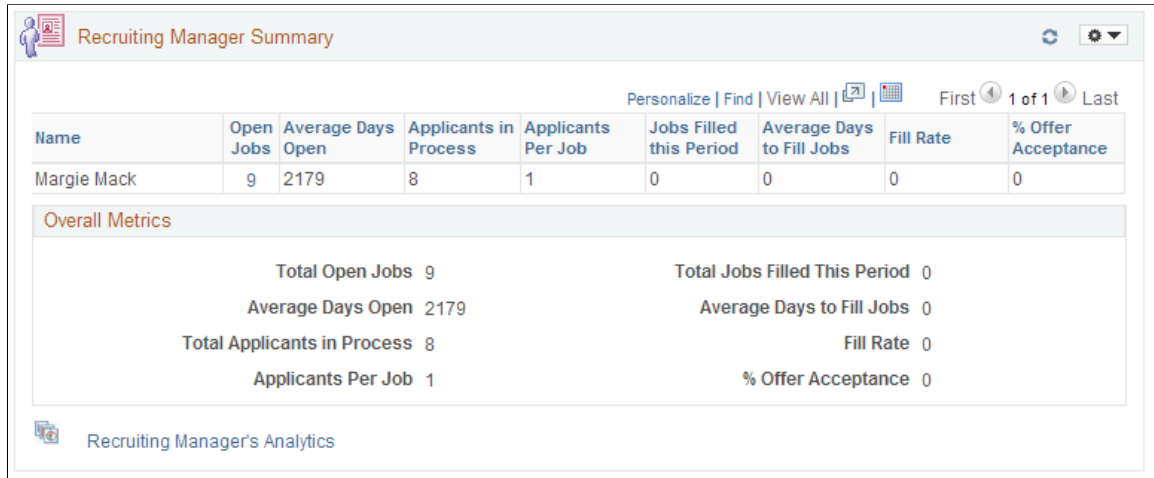

The Recruiting Manager Summary pagelet shows a variety of metrics to gauge the workload and effectiveness of a recruiting manager’s direct reports. All metrics are based on job openings where the direct report is the primary recruiter.

### Job Opening Security

Metrics for direct reports include data from all job openings where the direct report is the primary recruiter, regardless of whether the recruiting manager who is viewing the metrics is authorized to access those job openings.

However, when a recruiting manager drills into metrics to view details, job opening security hides any job openings that the manager is not authorized to access. For this reason, the number of openings in the detailed list may differ from the total count of open job openings shown on the pagelet.

### Determination of Direct Reports

The system determines the user’s direct reports based on the access type specified on the “Target Information Page” (Application Fundamentals). As delivered, the Recruiting Manager Summary pagelet uses the access type *By Part Posn Mgmt Supervisor*.

See “Setting Up Access to Direct Reports Data” (Application Fundamentals)

### Metrics for Direct Reports

<b>Field or Control</b>	<b>Description</b>
<b>Name</b>	Displays the name of the direct report.
<b>Open Jobs</b>	Displays the number of open job openings where the direct report is the primary recruiter. Click the link to access the Browse Job Openings page pre-filtered to show the direct report’s open job openings.

<b>Field or Control</b>	<b>Description</b>
<b>Average Days Open</b>	<p>Displays the average number of days that the jobs included in the <b>Open Jobs</b> count have been open. The average is rounded to the nearest whole number.</p> <p>The days open for a job opening is the number of days since the job opening's earliest posting date. If the job has never been posted, the days open is the number of days since the job opening was created. If the earliest job posting date (or, if none, the job creation date) is in the future, the days open is 0.</p>
<b>Applicants in Process</b>	<p>Displays the number of active applicants for the jobs included in the <b>Open Jobs</b> count.</p> <p>Applicants are considered active if they have non-Draft dispositions in any phase other than Reject or Hold.</p>
<b>Applicants per Job</b>	<p>Displays the average number of applicants per job opening based on the values in the <b>Open Jobs</b> field and the <b>Applicants in Process</b> field. The average is rounded to the nearest whole number.</p>
<b>Jobs Filled this Period</b>	<p>Displays how many of the direct report's job openings were filled during the period specified on the pagelet's personalization page. This includes only job openings where the direct report is the Primary Recruiter.</p> <p>Job openings are considered filled when the status changes to the status configured as the "Complete" job opening status. Under the delivered status configuration, this is the <i>110 Filled/Closed</i> status.</p>
<b>Average Days to Fill Jobs</b>	<p>Displays the average number of Days to Fill for the jobs filled this period. The average is rounded to the nearest whole number.</p> <p>A job opening's Time to Fill is the number of days between the earliest post date for the opening and the date when the job opening is filled. If the job opening was never posted, then Time to Fill is measured from the job opening creation date. If the job was filled before the earliest posting date (or, if the job wasn't posted, before the job creation date), the Days to Fill is zero.</p>



<i>Field or Control</i>	<i>Description</i>
<b>Fill Rate</b>	<p>Displays the direct report's fill rate, which is the Jobs Filled This Period value as a percentage of the number of open jobs during the same period. The fill rate is rounded to the nearest whole number.</p> <p>The number of jobs open during the period includes openings that were open at beginning of period and openings that were opened during the period. Cancelled jobs are removed from the equation.</p>
<b>% Offer Acceptance</b>	<p>Displays the direct report's offer acceptance rate, which is the number of offers accepted as a percentage of the number of offers extended during the same period. The offer acceptance rate is rounded to the nearest whole number.</p>

## Overall Metrics

The Overall Metrics group box displays summary data for all of the recruiting manager's direct reports. The fields are the same as those in the Direct Reports grid, but the values in the grid are aggregated to produce the overall metrics.

## Recruiting Manager Analytics

<i>Field or Control</i>	<i>Description</i>
<b>Recruiting Manager's Analytics</b>	<p>Click to display a menu listing the pivot grids, then select one of the following pivot grids to display:</p> <ul style="list-style-type: none"> <li>• Job Opening Aging Analysis</li> <li>• Job Opening Open and Close Trend</li> <li>• Time to Fill</li> </ul> <p>See <a href="#">Viewing Recruiting Pivot Grids</a>.</p> <hr/> <p><b>Note:</b> These pivot grids are also available from other pagelets on the Recruiting Home page. However, when accessed from the Recruiting Manager Summary pagelet, the pivot grids display data for all of the user's direct reports rather than just displaying the user's own data.</p> <hr/>

## Personalize Recruiting Manager Summary Page

Use the Personalize Recruiting Manager Summary page (HRS\_PE\_OPR\_MGR) to choose the time period to include in the recruiting manager metrics and to set filter options to control which types of applicants and job openings are included.

This example illustrates the Personalize Recruiting Manager Summary page.

### Personalize Recruiting Manager Summary

Specify the time period, types of applicants and whether to include hot jobs only for metric calculation and display.

**Time Period for Metrics**

Time Period (Last n Days)

**Filter Options**

Include External Applicants

Include Internal Applicants

Hot Jobs Only

Save
Cancel

### Time Period for Metrics

<i>Field or Control</i>	<i>Description</i>
<b>Time Period (Last n Days)</b>	Enter the number of days before today that the time period for recruiting manager metrics starts. The default value is 90.

### Filter Options

<i>Field or Control</i>	<i>Description</i>
<b>Include External Applicants and 'Include External Applicants</b>	Select one or both of these check boxes to indicate which types of applicants to include in recruiting manager metrics. The default setting is for both check boxes to be selected.
<b>Hot Jobs Only</b>	Select this check box to exclude job openings that are not hot jobs from the recruiting manager metrics. This check box is deselected by default.

---

## Viewing Classic Recruiting Pagelets

This topic describes the five recruiting pagelets that are grouped under the heading “Recruiting Solutions (Classic)” on the [Personalize Content Page](#) page (and on the page where you personalize your PeopleSoft

home page). These are older pagelets that remain available if users of previous releases prefer to work with pagelets that are they are more familiar with.

## Classic Recruiting Pagelets and Their Personalization Pages

This table provides summary information about the classic Recruiting pagelets:

<b>Pagelet Name</b>	<b>Description</b>	<b>Personalization Options</b>
<u>My Job Openings (Classic)</u> (HRS_PE_MY_JO)	Lists job openings that you created or where you are on the hiring team. Personalize the pagelet to control which of your job openings appear.	Use the <u>Personalize My Job Openings (Classic) Page</u> (HRS_PE_OPR_JOS) to specify the status and creation time frame of the openings to display on the My Job Openings (Classic) pagelet, and to specify data to display in the pagelet.
<u>Search Job Openings (Classic) Pagelet</u> (HRS_PE_JO_SRCH)	Perform a quick job opening search based on the job opening status and when it was created.	None
<u>Search Applications (Classic) Pagelet</u> (HRS_PE_APP_SRCH)	Perform a quick application search based on a limited set of criteria fields.	None
<u>Recent Job Openings (Classic) Pagelet</u> (HRS_PE_JO_APP_ALL)	Displays your five most recent open job openings.	None
<u>Quick Search (Classic) Pagelet</u> (HRS_PE_SRCH)	Provides several search options for applicants and job openings.  Depending on the search type, search results appear on the Search Applicants page, the Search Job Openings page, or, if you search for job openings with a particular hiring manager, on the <u>Quick Search (Classic) Results Page</u> .	None

### My Job Openings (Classic)

Use the My Job Openings (Classic) pagelet (HRS\_PE\_MY\_JO) to display job openings that you created or where you are on the hiring team. Personalize the pagelet to control which of your job openings appear. Personalizations include the job opening status and how long ago the job opening was created.

This example illustrates the My Job Openings (Classic) pagelet.

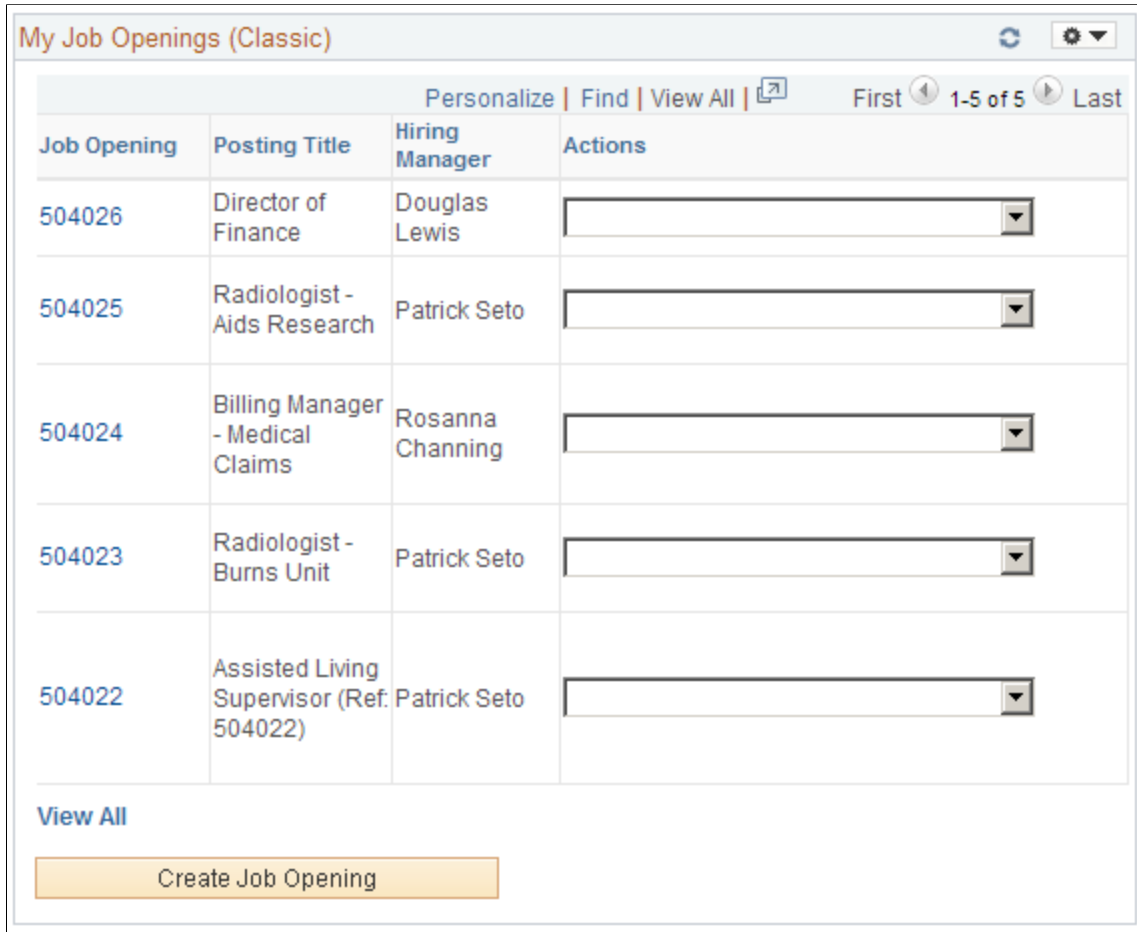

### List of Job Openings

**Note:** The personalization options for the pagelet offer 11 possible columns to include in the job openings grid, but the grid can only display a maximum of five columns.

<b>Field or Control</b>	<b>Description</b>
<b>Job Opening</b>	Displays the job opening ID. Click the link to access the Manage Job Opening page, where you can review detailed information about the job opening.
<b>Posting Title</b>	Displays the primary posting title for the job opening. Select the <b>Job Opening Title</b> check box on the Personalize My Job Openings page to display this value.
<b>Location</b>	Displays the primary location (not the recruiting location) for the job opening.

<b>Field or Control</b>	<b>Description</b>
<b>Hiring Manager</b>	Displays the primary hiring manager for the job opening.
<b>Status</b>	Displays the current status of the job opening.
<b>Days Open</b>	Displays the number of days since the job opening was approved and opened.
<b>Target Openings</b>	Displays the number of target openings for this job opening.
<b>Number Filled Openings</b>	Displays the number of openings that have been filled for this job opening.
<b>Total Applicants</b>	Displays the number of applicants attached to this job opening.
 <b>Activity</b>	Displays an <b>Activity</b> icon that you click to access the Manage Job Opening page: Activity & Attachments tab.
<b>Actions</b>	<p>Select an action to perform. The system launches the appropriate page for the action. Select from the following options:</p> <ul style="list-style-type: none"> <li>• <i>Search for Applicants</i>: Select to access the Manage Job Opening page: Applicant Search tab, where you can search for applicants for the job opening.</li> <li>• <i>Post Job Openings</i>: Select to access the Manage External Postings page, where you can post the job opening to an external job board or vendor.</li> <li>• <i>View Job Postings</i>: Select to access the Search Job Postings page, where you can search for job postings.</li> <li>• <i>Clone Job Openings</i>: Select to access the Clone Job Opening page, where you can copy the job opening to create a new opening.</li> <li>• <i>View Status History</i>: Select to access the Manage Job Opening page: Activity &amp; Attachments tab, where you can view the job history.</li> <li>• <i>Manage Applicants</i>: Select to access the Manage Job Opening page: Applicants tab, where you can manage recruiting processes for the job opening.</li> </ul>

## Additional Page Elements

<b>Field or Control</b>	<b>Description</b>
<b>View All</b>	Click this link to access the Browse Job Openings page. The personalization options for the pagelet do not persist when you transfer to the Browse Job Openings page.
<b>Create Job Opening</b>	Click to access the Primary Job Opening Information page where you can begin the process of creating a job opening.

## Personalize My Job Openings (Classic) Page

Use the Personalize My Job Openings (Classic) page (HRS\_PE\_OPR\_JOS) to define the content and layout of the My Job Openings (Classic) pagelet.

This example illustrates the Personalize My Job Openings (Classic) page.

### Personalize My Job Openings (Classic)

Select the information that should display on the pagelet. The values selected for Status Code and Created Within are the criteria that determine which Openings display on the pagelet. The selected values in the Additional Columns list determine which columns are displayed on the pagelet. The Job Opening column is preselected and will always display.

**My Job Openings**

With Status of 010 Open ▼

Created Within 070 - Last Year ▼

Maximum displayed rows 5

**Additional Columns (max. = 5)**

- Job Opening
- Posting Title
- Location
- Hiring Manager
- Status
- Days Open (Since Approval)
- Target Openings
- Number Filled Openings
- Total Applicants
- Job Opening Activity Hyperlink
- Actions

Save
[Return to Previous Page](#)

Use this page to define what information displays on the My Job Openings (Classic) pagelet.

### Row Selection Criteria

<i>Field or Control</i>	<i>Description</i>
<b>With Status of</b>	Select a status to filter the pagelet so it displays only job openings in the selected status. If you leave this field blank, the pagelet displays job openings regardless of status.
<b>Created Within</b>	Select a point in time from which you want to view job openings. For example, select <i>Last Month</i> to display your job openings for the last 30 days or <i>Last Week</i> to see your openings for the last seven days. If you leave this field blank, the pagelet does not display any job openings.
<b>Maximum displayed rows</b>	Enter the maximum number of job openings to display on the pagelet. The maximum value is 99.

### Additional Columns

The personalization page displays 11 check boxes representing columns that you can include in the job openings grid on the pagelet. Select the check boxes for the columns that you want to display.

The **Job Opening** check box must be selected. You can select up to four additional check boxes as well.

### Search Job Openings (Classic) Pagelet

Use the Search Job Openings (Classic) pagelet (HRS\_PE\_JO\_SRCH) to perform quick job opening searches based on the job opening status and when it was created.

This example illustrates the Search Job Openings (Classic) pagelet.

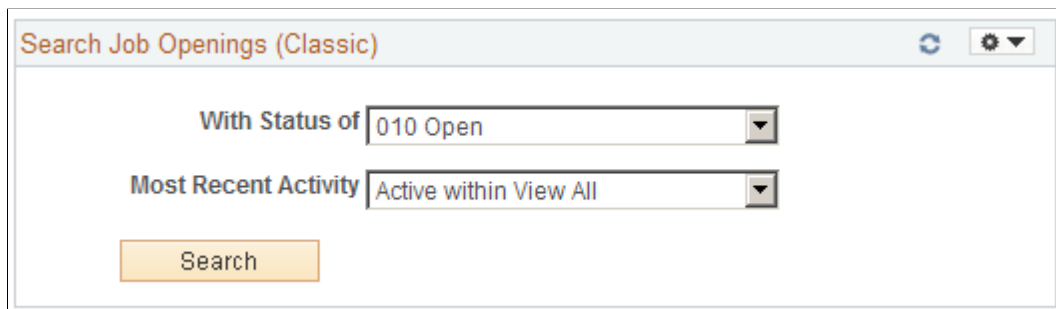

<i>Field or Control</i>	<i>Description</i>
<b>With Status of and Most Recent Activity</b>	Enter job opening search criteria. You can search based on the job opening status and on when the job opening status last changed.

<b>Field or Control</b>	<b>Description</b>
<b>Search</b>	Click to perform the search. The the search results appear on the Search Job Openings page.

## Search Applications (Classic) Pagelet

Use the Search Applications (Classic) pagelet (HRS\_PE\_APP\_SRCH) to perform quick application searches based on a limited set of criteria fields.

This example illustrates the Search Applications (Classic) pagelet.

<b>Field or Control</b>	<b>Description</b>
<b>Last Name and With Applicant Type</b>	Use these search criteria fields to search applications based on applicant-specific criteria, including the applicant’s last name and applicant type. Because an applicant can have multiple applications, searches based only on applicant data can show multiple results rows for a single applicant.
<b>With Disposition and Applied Within</b>	Use these search criteria fields to search applications based on application-specific criteria, including the applicant’s disposition and how recently the application was submitted.
<b>Job Opening</b>	Use this search criteria field to search applications based on the job opening. The drop-down list box shows the user’s 100 oldest open job openings (based on the job creation date). To search for a job opening that is not in the list, use the Search Applications page.
<b>Search</b>	Click to perform the search. The search results appear on the Search Applications page.



## Recent Job Openings (Classic) Pagelet

Use the Recent Job Openings (Classic) pagelet (HRS\_PE\_JO\_APP\_ALL) to view your five most recent open job openings.

This example illustrates the Recent Job Openings (Classic) pagelet.

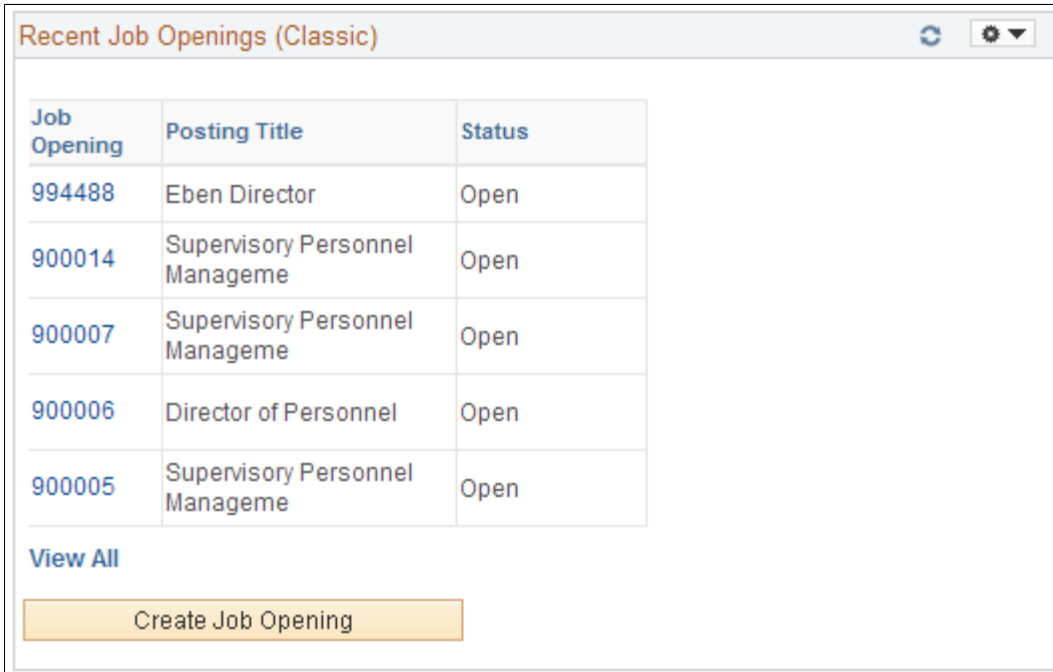

This pagelet displays basic information about your five most recent job openings.

<b>Field or Control</b>	<b>Description</b>
<b>Job Opening and Posting Title</b>	These fields display identifying information about the job opening. Click the job opening ID to access the Manage Job Opening page.
<b>Status</b>	Displays the status of the job opening.
<b>View All</b>	Click to access the <a href="#">Browse Job Openings Page</a> , where you can access all of your job openings using keyword searches and filter facets.
<b>Create Job Opening</b>	Click to access the <a href="#">Primary Job Opening Information Page</a> , where you start the process of creating a new job opening.

## Quick Search (Classic) Pagelet

Use the Quick Search (Classic) pagelet (HRS\_PE\_SRCH) to perform quick applicant and job opening searches.

This example illustrates the Quick Search (Classic) pagelet.

Use this pagelet to initiate a search for either applicants and job openings. Select a search option in the top field, then enter a corresponding value in the lower field and click **Search** to view search results on the appropriate Talent Acquisition Manager page.

Search options include:

- *Applicant (Last, First Name)*: Enter the applicant's last name and then first name, then search to view the search results on the Search Applicants page: Quick Search tab.
- *Hiring Manager (Name)*: Enter the hiring manager's first and last name, then search to view a list of job openings that are associated with the hiring manager. Results appear on the Quick Search (Classic) Results page.
- *Job Opening ID*: Enter the job opening number, then search to view the search results on the Search Job Openings page.
- *Keywords*: Enter text that you want to search for in a resume, then search to view the search results on the Search Applicants page: Keyword Search tab.

## Quick Search (Classic) Results Page

Use the Quick Search (Classic) Results page (HRS\_PE\_JO\_SRCHRES) to view results of a hiring manager search performed on the Quick Search (Classic) pagelet.

Navigation:

**Recruiting > Recruiting Home**

Perform a Hiring Manager search on the Quick Search (Classic) pagelet.

This example illustrates the Quick Search (Classic) Results page.

Quick Search (Classic) Results									
Search Results					Personalize	View All	First	1-25 of 37	Last
Job Opening	Posting Title	Hiring Manager	Status	Location	Days Open	Target Openings	Filled Openings	Total Applicants	
100121	System Administrator	Jake Oglevy	Open	San Francisco	4162	1	0	0	
100120	Web Designer	Jake Oglevy	Open	San Francisco	4162	1	0	0	
100109	Guest Services Manager	Jake Oglevy	Open	Aspen	4186	1	0	1	

<b>Field or Control</b>	<b>Description</b>
<b>Search Results</b>	<p>This grid lists job openings that meet your hiring manager search criteria. It is not necessary for the person to be the primary hiring manager.</p> <p>The fields in this grid are the same as those on the <a href="#">My Job Openings Pagelet</a>.</p>

## Viewing Recruiting Pivot Grids

This topic discusses recruiting pivot grids.

### Pages Used to View Recruiting Pivot Grids

**Note:** Pivot grids are accessed from pagelets. Pagelets can be added to a user's PeopleSoft home page or to the [Recruiting Home Page](#).

<b>Pivot Grid Name</b>	<b>Definition Name</b>	<b>Usage</b>
<a href="#">Job Opening Open and Close Trend Pivot Grid</a>	<ul style="list-style-type: none"> <li>HRS_PG_JO_OC (pivot grid accessed from the My Job Openings pagelet)</li> <li>HRS_PG_JO_OC_M (pivot grid accessed from the Recruiting Manager Summary pagelet)</li> </ul>	View the number of openings that were opened and closed each month.
<a href="#">Job Opening Aging Analysis Pivot Grid</a>	<ul style="list-style-type: none"> <li>HRS_PG_JO_AGE (pivot grid accessed from the My Job Openings pagelet)</li> <li>HRS_PG_JO_AGE_M (pivot grid accessed from the Recruiting Manager Summary pagelet)</li> </ul>	View the number of open job openings of various ages.
<a href="#">In Process Applicants Pivot Grid</a>	HRS_PG_INPRC_APPL	View the distribution of dispositions for your active applicants.
<a href="#">Time to Fill Pivot Grid</a>	<ul style="list-style-type: none"> <li>HRS_PG_TTF_DB (simplified pivot grid shown on the Time to Fill pagelet)</li> <li>HRS_PG_TTF (pivot grid accessed through the related action on the Time to Fill pagelet)</li> <li>HRS_PG_TTF_M (pivot grid accessed from the Recruiting Manager Summary pagelet)</li> </ul>	View the average number of days to fill job openings by month.

## Understanding Recruiting Pivot Grids

PeopleSoft Pivot Grid is a PeopleTools technology that provides actionable operational analytics using charts and grids. Pivot grids enable users to visually display real-time data and organize it on the fly by pivoting and filtering. The self-service, multi-dimensional analytics provided by PeopleSoft Pivot Grid provides users with the business intelligence needed to make informed decisions.

Recruiting Solutions delivers four pivot grids that provide graphic views of important performance measures:

- The Job Opening Open and Close Trend chart shows data related to the number of openings that are opened and closed on a monthly basis, giving users a picture of hiring activity across time, departments and locations.
- The Job Opening Aging Analysis chart shows the number of open job openings in various pre-defined age bands, providing vital information about an organization's recruiting backlog.
- The In Process Applicants chart shows the distribution of dispositions for applicants who are being considered for job openings, offering a view of the applicant pipeline.
- The Time to Fill chart shows monthly average Time to Fill data, helping users to see trends in their ability to fill job openings.

---

**Note:** This data is available to recruiters, recruiting managers, recruitment administrators, and hiring managers based on their security access, or if they are part of the hiring team. They can access the pivot data through various pagelets.

---

For more information on the setup and capabilities of PeopleSoft Pivot Grid, see *PeopleTools: Pivot Grid*.

## Common Elements for Viewing Pivot Grids

These page controls appear on all Recruiting pivot grids:

<b>Field or Control</b>	<b>Description</b>
	<p>Click to open the Options Menu, then select from these menu items:</p> <ul style="list-style-type: none"> <li>• <i>Prompts</i>: Displays a dialog box where you can change the parameters used to define the chart's data set.</li> <li>• <i>View Grid</i>: Opens an additional dialog box that displays the data in a grid format rather than a chart format.</li> <li>• <i>Export Data</i>: Exports the underlying PSQuery data to a spreadsheet.</li> <li>• <i>Chart Options</i>: Opens the User Charting Options dialog box, where you can change the chart labels, layout, axes, and filters.</li> <li>• <i>Save</i>: Saves the current grid and chart layout as the default view</li> </ul>

<b>Field or Control</b>	<b>Description</b>
<b>Filters</b>	Displays drop-down list boxes that you use to filter the data to be displayed in the chart.
<b>&lt;Drilldown Menu&gt;</b>	<p>When you click a data element (for example, a bar on a bar chart), a menu provides these options:</p> <ul style="list-style-type: none"> <li>• <i>Detailed View</i>: Displays a grid with the detailed data. For example, if a bar on a bar chart represents the number of job openings that were filled in a particular month, clicking Detailed View displays a grid with information about each of the included job openings.</li> <li>• <i>Drilldown To</i>: Displays the drilldown options defined for the chart. Clicking a drilldown option redraws the chart based on the selected type of data.</li> </ul>

## Job Opening Open and Close Trend Pivot Grid

Use the Job Opening Open and Close Trend pivot grid to view the number of openings that were opened and closed each month.

Navigation:

This pivot grid is accessed from pagelets that you can add to your PeopleSoft home page or to the [Recruiting Home Page](#).

- On the My Job Openings pagelet, click the **My Job Openings Analytics** link, then click the **Job Opening Open and Close Trend** option.
- On the Recruiting Manager Summary pagelet, click the **Recruiting Manager's Analytics** link, then click the **Job Opening Open and Close Trend** option.

This example illustrates the Job Opening Open and Close Trend pivot grid.



The Job Opening Open and Close Trend pivot grid displays monthly job opening data. By default, the data appears as a bar chart. For each month, one bar represents the number of job openings that were opened, and a second bar represent the number of job openings that were filled.

The opening date for a job opening is considered to be the earliest posting date or, if there are no postings defined, the actual job opening date. The closing date is the date that the job opening status changed to *Filled/Closed*.

### Chart Content and Layout

The following table describes options for manipulating the chart:

Option	Details
 Prompts	Enter the <b>From Date</b> and <b>To Date</b> to define the date range for the pivot grid.  Initially, the chart displays data for the past year.

<b>Option</b>	<b>Details</b>
Filters	<ul style="list-style-type: none"> <li>• Recruiter</li> <li>• Business Unit</li> <li>• Job Family</li> <li>• Country</li> </ul>
Drill-down options	<ul style="list-style-type: none"> <li>• Department</li> <li>• Job Code</li> <li>• Location</li> </ul>
Chart type options	<ul style="list-style-type: none"> <li>• Bar chart</li> <li>• Line chart</li> <li>• Horizontal bar chart</li> </ul>

## Job Opening Aging Analysis Pivot Grid

Use the Job Opening Aging Analysis pivot grid to view the number of open job openings of various ages.

---

**Note:** Continuous job openings, which remain open indefinitely, are not included in the data for this chart.

---

Navigation:

This pivot grid is accessed from pagelets that you can add to your PeopleSoft home page or to the [Recruiting Home Page](#).

- On the My Job Openings pagelet, click the **My Job Openings Analytics** link, then click the **Job Opening Aging Analysis** option.
- On the Recruiting Manager Summary pagelet, click the **Recruiting Manager's Analytics** link, then click the **Job Opening Aging Analysis** option.

This example illustrates the Job Opening Aging Analysis pivot grid.

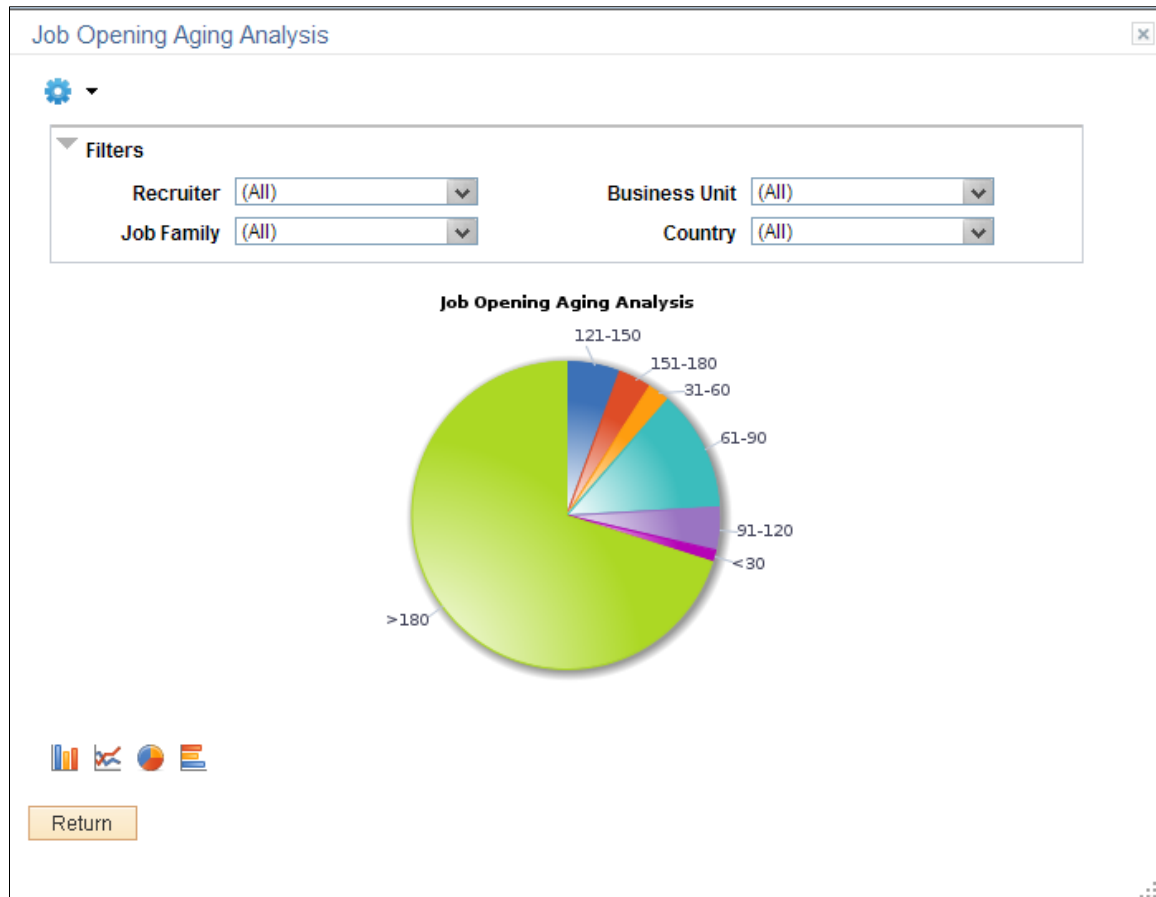

The Job Opening Aging Analysis pivot grid displays counts of open job openings in predetermined age bands. The age bands are <30 days, 31–60 days, 61–90 days, 91–120 days, 121–150 days, 151–180 days, and > 180 days.

A job's age is the number of days since the earliest posting date or, if no postings exist, the number of days since the date the job was opened.

By default, the data appears as a pie chart.

### Chart Content and Layout

The following table describes options for manipulating the chart:



<b>Option</b>	<b>Details</b>
 <p>Prompts</p>	<p>Enter the <b>From Date</b> to define the date range for the pivot grid. Only jobs opened on or after the specified date are included in the chart.</p> <p>Initially, the chart includes data for jobs that were opened within the past year.</p> <hr/> <p><b>Note:</b> Because the My Job Openings pagelet shows jobs based on the creation date, not the posting date, the number of job openings represented in the chart does not necessarily match the number in the pagelet even when both are looking at data from the same period of time.</p> <hr/>
Filters	<ul style="list-style-type: none"> <li>• Recruiter</li> <li>• Business Unit</li> <li>• Job Family</li> <li>• Country</li> </ul>
Drill-down options	<ul style="list-style-type: none"> <li>• Company</li> <li>• Department</li> <li>• Job Opening</li> <li>• Job Code</li> <li>• Location</li> </ul>
Chart type options	<ul style="list-style-type: none"> <li>• Bar chart</li> <li>• Line chart</li> <li>• Pie chart</li> <li>• Horizontal bar chart</li> </ul>

## In Process Applicants Pivot Grid

Use the In Process Applicants pivot grid to view the distribution of dispositions for applicants who are being considered for job openings.

Navigation:

This pivot grid is accessed from the My Applicants pagelet. You can add this pagelet to your PeopleSoft home page or to the [Recruiting Home Page](#).

On the My Applicants pagelet, click the **My Applicants Analytics** link, then click the **In Process Applicants** option.

This example illustrates the In Process Applicants pivot grid.

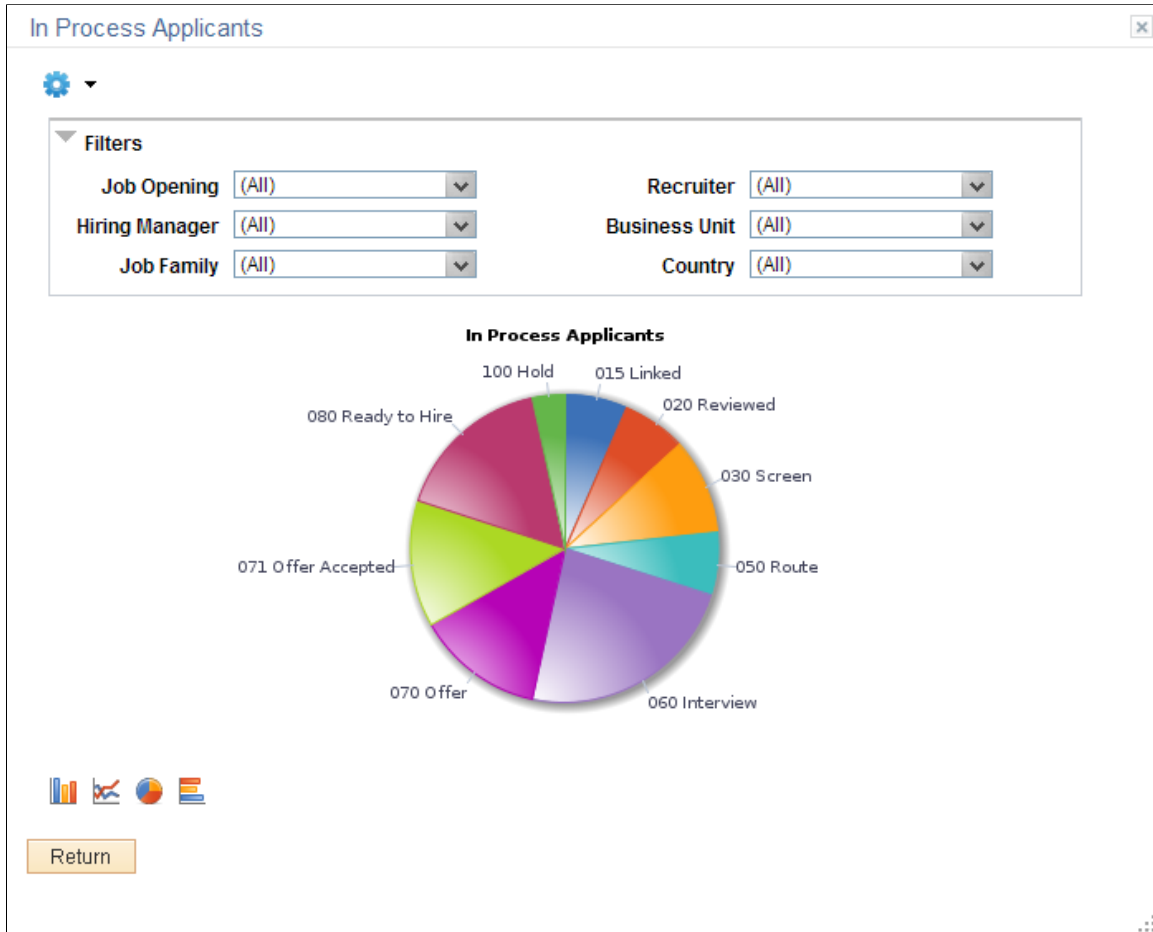

The In Process Applicants pivot grid displays counts of applicants in various dispositions. The chart shows all in-use dispositions except *Draft* and *Reject*.

By default, the data appears as a pie chart.

### Chart Content and Layout

The following table describes options for manipulating the chart:

Option	Details
 <p>Prompts</p>	<p>Enter the <b>From Date</b> and <b>To Date</b> to define the date range for the pivot grid. Only applications that were created within the specified date range are included in the chart.</p> <p>Enter <i>Y</i> (yes) or <i>N</i> (no) in the <b>Include Applied Status</b> field to determine whether the chart includes applications in the default disposition that is assigned when the application is first submitted. The delivered default disposition is <i>Applied</i>.</p> <p>Initially, the chart includes data for jobs that were opened within the past year, and it does not include applications in the default (<i>Applied</i>) disposition.</p>

<b>Option</b>	<b>Details</b>
Filters	<ul style="list-style-type: none"> <li>• Job Opening</li> <li>• Recruiter</li> <li>• Job Family</li> <li>• Country</li> <li>• Hiring Manager</li> <li>• Business Unit</li> </ul>
Drill-down options	<ul style="list-style-type: none"> <li>• Department</li> <li>• Location</li> </ul>
Chart type options	<ul style="list-style-type: none"> <li>• Bar chart</li> <li>• Line chart</li> <li>• Pie chart</li> <li>• Horizontal bar chart</li> </ul>

## Time to Fill Pivot Grid

Use the Time to Fill pivot grid to view the average number of days to fill job openings by month.

Navigation:

This pivot grid is accessed from pagelets that you can add to your PeopleSoft home page or to the [Recruiting Home Page](#).

- A simplified version of this pivot grid appears directly on the Time to Fill pagelet.
- On the Time to Fill pagelet, click the **Time to Fill Analytics** link, then click the **Time to Fill** option.
- On the Recruiting Manager Summary pagelet, click the **Recruiting Manager's Analytics** link, then click the **Time to Fill** option.

This example illustrates the Time to Fill pivot grid.

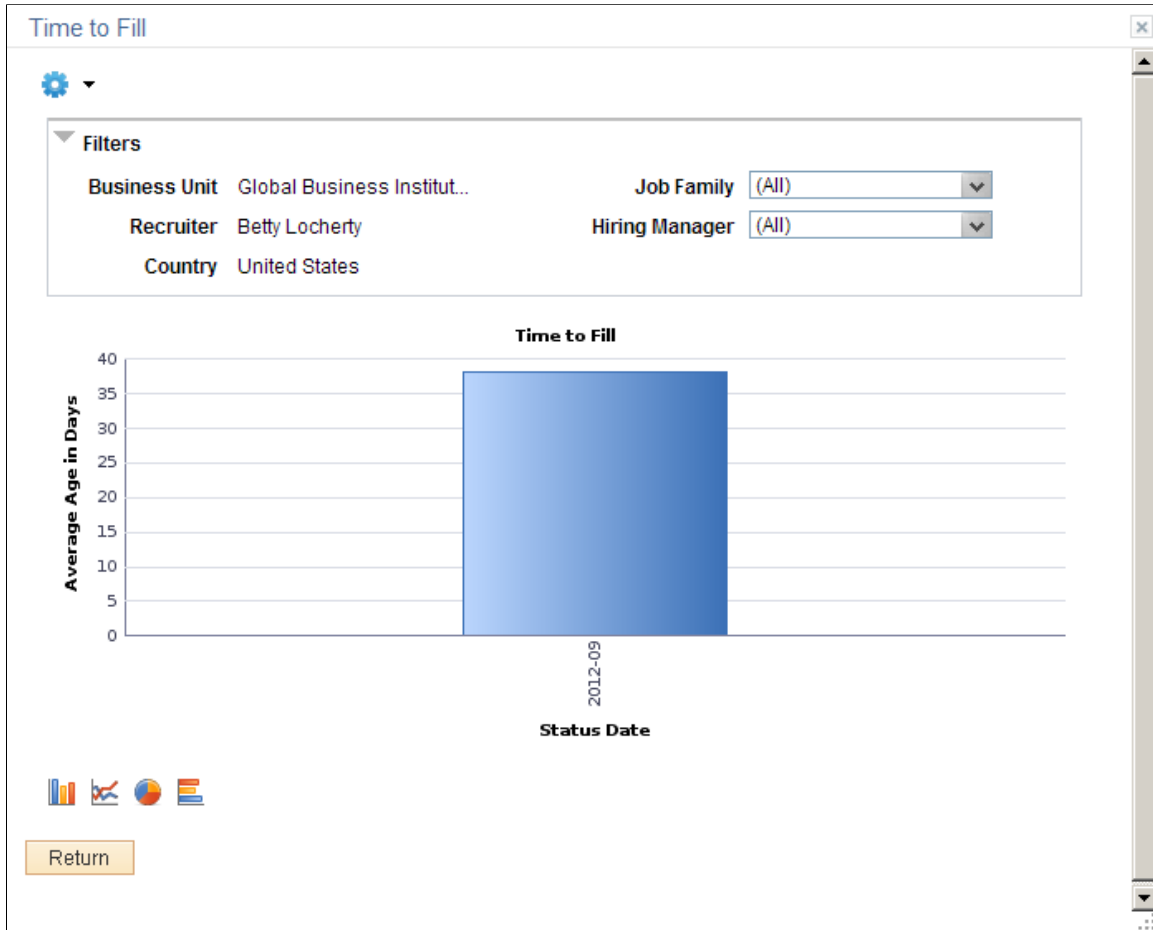

The Time to Fill pivot grid displays the average days taken to fill the job openings that are closed in a particular month.

### Chart Content and Layout

The following table describes options for manipulating the chart:

<b>Option</b>	<b>Details</b>
 Prompts	<ul style="list-style-type: none"> <li>When launched from the Recruiting Manager Summary pagelet, <b>From Date</b> and <b>To Date</b> prompts define the date range for the chart. The chart displays monthly Time to Fill data for the specified period.  Initially, the chart includes data for the past year.</li> <li>When launched from the Time to Fill pagelet, there are no prompts. The date range for the chart is determined by the personalization options on the pagelet.</li> </ul>

<b>Option</b>	<b>Details</b>
Filters	<ul style="list-style-type: none"> <li>• Business Unit</li> <li>• Job Family</li> <li>• Country</li> <li>• Recruiter</li> <li>• Hiring Manager</li> </ul>
Drill-down options	<ul style="list-style-type: none"> <li>• Department</li> <li>• Job Code</li> <li>• Location</li> </ul>
Chart type options	<ul style="list-style-type: none"> <li>• Bar chart</li> <li>• Line chart</li> <li>• Pie chart</li> <li>• Horizontal bar chart</li> </ul>

---

## Using Diversity Analytics

This topic discusses diversity analytics for recruiting.

These videos demonstrate the diversity analytics:

Video: [PeopleSoft HCM 9.2 Image 19 Highlights: Diversity Analytics \(Diversity Overview Pivot Grid\)](#)

Video: [PeopleSoft HCM 9.2 Image 20 Highlights: Diversity Analytics \(Diversity By Applications Pivot Grid\)](#)

## Pages Used for Diversity Analytics

<b>Page Name</b>	<b>Definition Name</b>	<b>Usage</b>
<a href="#">Refresh Diversity Analytics Page</a>	HRS_RUN_DIVERSITY	Run the two application engine processes that load diversity data into the diversity analytics tables.
<a href="#">Applicant Diversity Overview Pivot Grid</a>	HRS_PG_DIV_OV1	View diversity data by applicant.

<b>Page Name</b>	<b>Definition Name</b>	<b>Usage</b>
<a href="#">Diversity By Applications Pivot Grid</a>	HRS_PG_DA_APPLN	View diversity data by application.

## Understanding Diversity Analytics

Diversity analytics provide a mechanism to review your recruitment practices and your compliance with affirmative action and equal employment opportunity programs. The Diversity analytics are pivot grids that chart information about four important types of diversity: disability, ethnicity, gender, and veteran status. The charts offer a variety of filter criteria for viewing specific slices of data.

### Diversity Charts

The system provides two pivot grids with different ways of looking at diversity information:

- *Applicant Diversity Overview*: This pivot grid counts each included applicant just once, regardless of how many times the applicant has applied. You can see applicant data for all four diversity types at once, or you can drill down for a closer look at a specific diversity type.
- *Diversity by Application*: This pivot grid counts each application separately, so an applicant who applies for multiple jobs is counted once for each application. (However, if an applicant has more than one application for a single job opening, only the most recent application is counted.) This pivot grid shows one diversity type at a time and provides prompts so you can change which diversity type is displayed.

Access both charts from the [Diversity Analytics Pagelet](#) on the Recruiting Home page.

### Effective Dated Diversity Data

Disability and veteran statuses are both effective dated. Gender and ethnicity data is not effective-dated.

The two pivot grids handle the effective-dated data differently:

- The *Applicant Diversity Overview* pivot grid always shows current applicant data. This is appropriate for an analysis of applicants (rather than applications).
- The *Diversity by Application* pivot grid uses the disability and veteran information from the time of the most recent disposition change. This architecture supports the ability to analyze the diversity of your applicant pool at different stages of the recruiting process. For example, you can compare the diversity of all applicants who apply versus the diversity of applicants who reach the interview phase, the offer phase, and the hiring phase. This analysis involved drilling down to view the data by disposition.

See [Diversity By Applications Pivot Grid](#)

### Notes on Specific Diversity Values

This list provides important information about certain diversity values that appear in the charts:

- *Multiple Ethnicities*: An applicant with more than one ethnic group is classified as *Multiple* in the diversity analytics charts.

- *Disability Data:* An applicant who does not have data in the USA-specific Section 503 Disability Status section of the [Create Applicant page: Eligibility & Identity Tab](#) is still considered disabled if the non-country specific Disability check box is selected on that same page.
- *Not Indicated or Unknown Diversity Data:* The labels *Not Indicated* (for disability, ethnicity, and veteran status) and *Unknown* (for gender) are actual database values that are delivered by PeopleSoft.

### Loading Diversity Data

The pivot grids for diversity analytics do not read data directly from the main recruiting tables. Instead, two Application Engine processes load diversity data into dedicated analytics tables:

- The Refresh Diversity Analytics process (HRS\_PG\_DA) loads data for the Applicant Diversity Overview pivot grid.
- The Refresh Application Diversity process (HRS\_DA\_APPLICATION) loads data for the Diversity by Application pivot grid.

When you run this process, you can specify the date range for the data to be loaded. Applicants are loaded if they submitted applications with or without a job opening in the specified date range. However, the process does not load applicant data for:

- Applications in *Draft* status.
- Applications in *Withdrawn* status with a reason of *Candidate Withdrawn*.
- Applications in *Inactive* status.
- Applicants in *Inactive* or *Queued* status.

### Refresh Diversity Analytics Page

Use the Refresh Diversity Analytics page (HRS\_RUN\_DIVERSITY) to run the two application engine processes that load diversity data into the diversity analytics tables.

Navigation:

**Recruiting > Administration > Refresh Diversity Analytics**

This example illustrates the Refresh Diversity Analytics page.

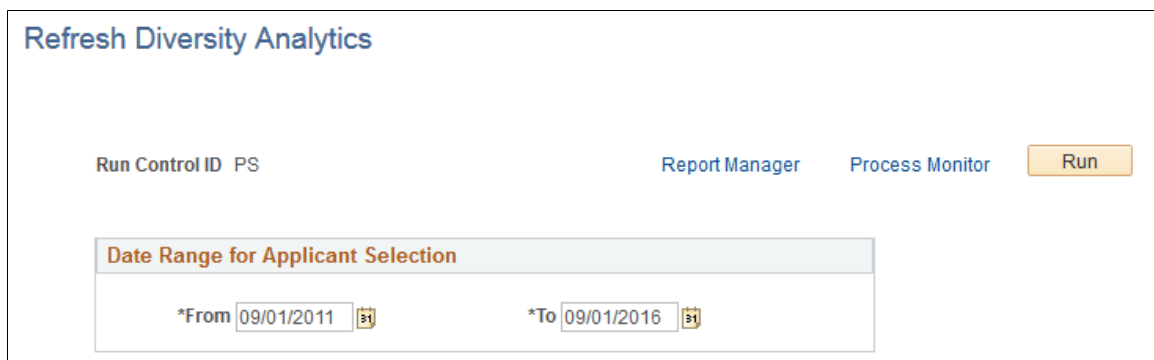

<b>Field or Control</b>	<b>Description</b>
<b>Run</b>	Click this button to access the PeopleSoft Process Scheduler Request page, where you schedule the Refresh Diversity Analytics process, the Refresh Application Diversity process, or both.

### Date Range for Applicant Selection

<b>Field or Control</b>	<b>Description</b>
<b>From and To</b>	Specify a date range for the process. The system loads diversity data for applicants who submitted applications (with or without a job opening) within the specified date range.  The default date range extends back five years from the current date.

## Applicant Diversity Overview Pivot Grid

Use the Applicant Diversity Overview pivot grid (HRS\_PG\_DIV\_OV1) to view diversity data by applicant.

**Note:** This chart counts each applicant once, regardless of how many applications have been submitted.

Navigation:

Access the Diversity Analytics pagelet on the Recruiting Home page. Click the Diversity Analytics menu, then select the Applicant Diversity Overview menu item.

This example illustrates the Applicant Diversity Overview pivot grid.

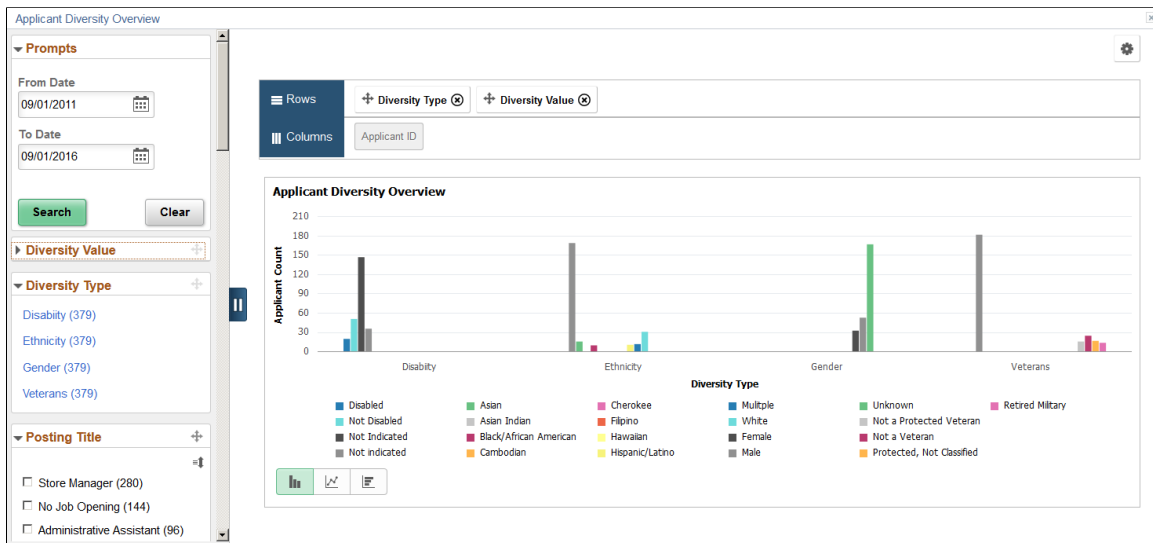



The Diversity Overview pivot grid includes a left frame with prompts and filters and a right frame with a chart.

## General Pivot Grid Functionality

Pivot grids are a feature of PeopleTools. For general information on setting up and using pivot grids, see *PeopleTools: Pivot Grid*. This topic does not discuss the generic pivot grid page controls such as the Rows and Columns controls or the Options icon in the top right corner.

## Chart

When the page first opens, it displays a bar chart with four types of diversity data: *Disability*, *Ethnicity*, *Gender*, and *Veterans* (veteran status). The bars for each diversity type are clustered together, creating the effect of four bar charts side-by-side.

When all four diversity types are displayed, mouseover text can help you match data bars to the labels in the legend. Hover over a bar to see the label, or hover over a label to highlight the associated bar.

Use standard pivot grid controls to change the chart to a line chart or a horizontal bar chart.

## Prompts

<i>Field or Control</i>	<i>Description</i>
<b>From Date and To Date</b>	<p>Enter the date range that you want to analyze. The pivot grid displays data for applicants with applications that were submitted within the specified date range.</p> <p>The default date range extends back one month from the current date.</p> <p>The selected date range determines which applicants are included in the chart, but it is not used to look up effective-dated diversity data. Rather, the chart always displays the current data for an applicant.</p>
<b>Search</b>	<p>Click to refresh the chart based on the date range that you specify.</p>

## Filters

For the first two filters, **Diversity Value** and **Diversity Type**, you apply the filter by clicking the link for a single value. For all other filters, there are check boxes next to the values, and you can select multiple values to include in your data set.

An explanation of the counts that appear next to each filter value appears after this list of filters.

<b>Field or Control</b>	<b>Description</b>
<b>Diversity Value</b>	This filter includes specific values for all of the different types of diversity shown in the chart. Because this filter initially includes a mix of values that apply to gender, ethnicity, disability status, and veteran status, it is usually easiest to filter by diversity type before filtering by diversity value.
<b>Diversity Type</b>	These filter values represent the four types of data included in the chart: <i>Disability</i> , <i>Ethnicity</i> , <i>Gender</i> , and <i>Veterans</i> . Click a value to update the chart so that it shows only data related to the selected diversity type.
<b>Posting Title</b>	Filtering by posting title is useful when you want to eventually drill down to a single job opening. Filtering by posting title reduces the number of values in the Job Opening ID filter to a more manageable list.  Applications that do not include a job opening have a posting title of <i>No Job Opening</i> .
<b>Job Opening ID</b>	Use this filter to review the diversity data for specific job openings.  Applications that do not include a job opening have a job opening ID of <i>0</i> (zero).
<b>Applicant Status</b>	These filter values represent the applicant's overall status, not the disposition of specific applications. Applicants that are included in this analytic always have a status of <i>Active</i> or <i>Hired</i> .
<b>Recruiter</b>	Enables you to filter based on the primary recruiter for the job opening.
<b>Hiring Manager</b>	Enables you to filter based on the primary hiring manager for the job opening.
<b>Jobcode</b>	Enables you to filter based on the primary job code for the job opening.
<b>Job Family</b>	Enables you to filter based on the job family for the job opening.

<b>Field or Control</b>	<b>Description</b>
<b>Recruiting Location</b>	Enables you to filter based on the primary recruiting location for the job opening.
<b>Business Unit</b>	Enables you to filter based on the business unit of the job opening.
<b>Department</b>	Enables you to filter based on the department of the job opening.

### Understanding the Counts That Appear Next To Filter Options

In the Applicant Diversity Overview chart, the counts that appear next to the filter options do not necessarily correspond to the number of applicants who have a particular attribute. This peculiarity is related to the fact that the underlying table stores data by job application rather than applicant. This architecture enables you to review diversity data based on job-related criteria—for example, you can look at applicant diversity for specific departments or recruiting locations.

To understand how the filter counts work, consider the example of Maya Hill, who submitted three applications. The analytics table therefore has three rows of data for Maya. Maya’s diversity information is included in the chart as long as any of her three applications meet your filtering criteria.

In the bar chart on the right frame of the page, each diversity type counts Maya just once, regardless of how many applications she submitted. That is, Maya is counted as one female, not three, even though she has three applications, as shown in the following illustration.

This example illustrates the Applicant Diversity Overview pivot grid for a data set that includes one applicant with three applications. The chart shows one applicant for each diversity type.

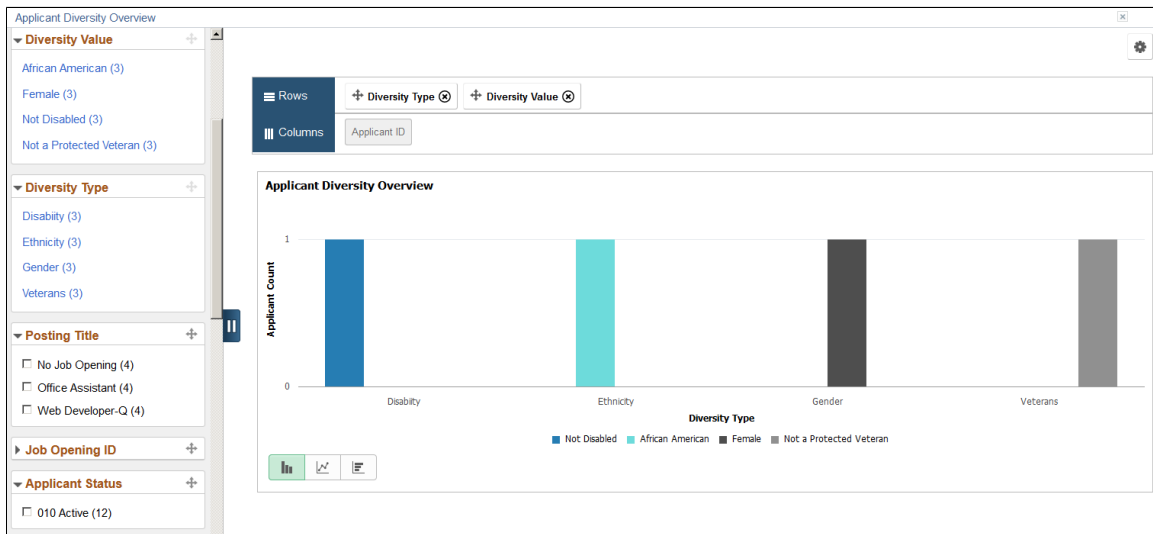

Although the chart counts Maya once per diversity type, the counts that appear in parentheses next to filter values count each of Maya’s applications *and* each of Maya’s diversity types. The following table

summarizes how this works. The Example column refers to Maya's three applications as shown in the previous illustration.

<b>Filter</b>	<b>Associated Count</b>	<b>Example</b>
Diversity Value	Counts applications.	Maya submitted three applications, so even though the bar chart shows that there is one female, the Female filter shows a count of 3.
Diversity Type	Counts applications.  All diversity types have the same count because every application is considered for each diversity type.	All four diversity types show a count of 3 because Maya submitted three applications.
All other filters	When all four diversity types appear in the chart, the count for these filters is four times the number of applications that meet the criteria. This is because each application is counted once for each diversity type.  If you filter the chart to show only one diversity type, then the counts for these other filters match the number of applications.	Each of Maya's three job applications are represented four times in the chart: once for disability, once for ethnicity, once for gender, and once for veteran status. So a filter value that includes one of Maya's application applications shows a count of 4.  The Applicant Status filter, however, has a higher count. Maya's application status, <i>Active</i> , does not vary by application, so the Active filter includes all three applications. Because each application is counted four times (for the four diversity types), Maya's count for this filter is 12.

## Reviewing Detailed Data

If you drill down into the chart, you can access a grid that displays the source data. The grid lists job applications, so individual applicants can appear more than once.

The grid that appears on-screen when you drill down into the chart shows a maximum of 100 rows. To view the complete data set, use the standard pivot grid export option by clicking the Options icon in the top right corner of the chart. The export is limited to data that falls within the date range you specify in the **Prompt** fields, but all other filter criteria is ignored.

## Diversity By Applications Pivot Grid

Use the Diversity by Applications pivot grid (HRS\_PG\_DA\_APPLN) to view diversity data by application.

**Note:** If an applicant applies for multiple jobs within the specified date range, this chart counts each application separately. If an applicant has more than one application for a single job opening, only the most recent application is counted.

Navigation:

Access the Diversity Analytics pagelet on the Recruiting Home page. Click the Diversity Analytics menu, then select the Diversity by Applications menu item.

This example illustrates the Diversity by Applications pivot grid.

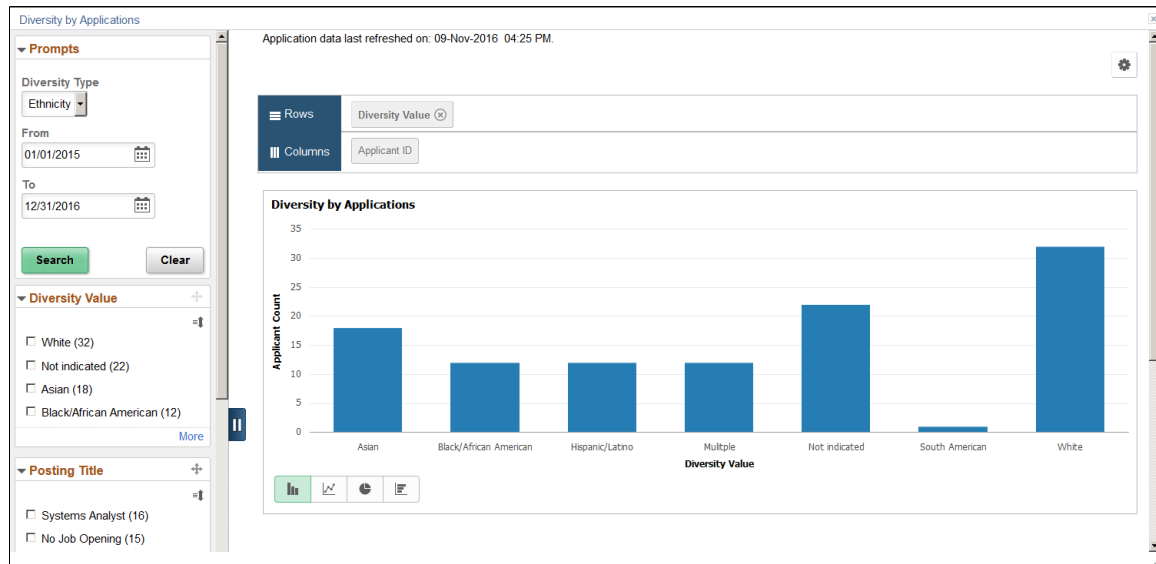

## General Pivot Grid Functionality

Pivot grids are a feature of PeopleTools. For general information on setting up and using pivot grids, see *PeopleTools: Pivot Grid*. This topic does not discuss the generic pivot grid page controls such as the Rows and Columns controls or the Options icon in the top right corner.

## Chart

When the page first opens, it displays a bar chart showing gender information for applications that were submitted in the last month. Use standard pivot grid controls to change the chart type, to drill down into the chart, or to view the underlying data in grid form.

## Effective-Dated Diversity Information

Gender data and ethnicity data are not effective dated. The applications that are included in the chart are always associated with the applicant's current gender and ethnicity data.

Disability and veteran information are effective dated. Each application is associated with the disability and veteran information that was effective as of the most recent disposition change.

For example, Marcus was not disabled on January 15 when he applied for two jobs, Job A and Job B. He passed screening for both jobs, resulting in a disposition change to *Screen*.

On January 30, while still in the *Screen* disposition for both jobs, Marcus became disabled, and his new disability information was entered into the system. In spite of this change, the Diversity by Applications

chart still shows a *Not Disabled* value for both applications because Marcus was not disabled at the time of the most recent disposition change. This presentation reflects the fact that Marcus's disability status is unrelated to his screening results.

In February, Marcus was asked to interview for Job A, and his disposition for that job changed to *Interview*. At this point, the chart shows a *Disabled* value for Job A because Marcus was disabled at the time of the most recent disposition change. However, the chart still shows a *Not Disabled* value for Job B because the *Screen* disposition has not changed.

In March, Marcus was hired for Job A, so his Job A disposition changed to *Hired* and his job B disposition changed to *Rejected*. He was still disabled at the time of these disposition changes, so at this point the chart shows that his disability value for both applications is now *Disabled*.

## Prompts

<b>Field or Control</b>	<b>Description</b>
<b>Diversity Type</b>	The default diversity type for the chart is <i>Gender</i> . Select <i>Disability</i> , <i>Ethnicity</i> , or <i>Veterans</i> to change the diversity type on the chart.
<b>From Date and To Date</b>	<p>Enter the date range that you want to analyze. The pivot grid displays data for applications that were submitted within the specified date range.</p> <p>The default date range extends back one month from the current date.</p> <p>The date range you specify here controls which applications are included in the chart, but once an application is included, these dates are not used when looking up the disability or veteran status for the application. For example, if an application's disposition changes after the specified To Date, the disposition date (and not the To Date) is used to look up the associated disability and veteran status.</p>
<b>Search</b>	Click to refresh the chart based on the date range that you specify.

## Filters

To filter the diversity data, select the check boxes next to the values that you want to include. You can select multiple filters to define your data set.

The number next to each filter value is the count of how many applications have that value.

<b>Field or Control</b>	<b>Description</b>
<b>Diversity Value</b>	This filter includes values that are specific to the diversity type shown in the chart. For example, if the chart displays gender data, filter values can include Female, Male, and Unknown.
<b>Posting Title</b>	Filtering by posting title is useful when you want to eventually drill down to a single job opening. Filtering by posting title reduces the number of values in the Job Opening ID filter to a more manageable list.  Applications that do not include a job opening have a posting title of <i>No Job Opening</i> .
<b>Job Opening ID</b>	Use this filter to review the diversity data for specific job openings.  Applications that do not include a job opening have a job opening ID of 0 (zero).
<b>Recruiter</b>	Enables you to filter based on the primary recruiter for the job opening.
<b>Hiring Manager</b>	Enables you to filter based on the primary hiring manager for the job opening.
<b>Jobcode</b>	Enables you to filter based on the primary job code for the job opening.
<b>Application Month</b>	Enables you to filter based on the month that the application was submitted.

## Reviewing Detailed Data

If you drill down into the chart, you can access a grid that displays the source data. The grid lists job applications, so individual applicants can appear more than once.

The grid that appears on-screen when you drill down into the chart shows a maximum of 100 rows. To view the complete data set, use the standard pivot grid export option by clicking the Options icon in the top right corner of the chart. The export is limited to data that meetings the criteria you specify in the **Prompt** fields, but all other filter criteria is ignored.





# Using the PeopleSoft Fluid User Interface to Manage Recruiting

---

## Using the Recruiting Homepage

PeopleSoft delivers the Fluid Recruiting Homepage with various tiles which enable Recruiters, Recruiting Managers and Recruiting Administrators to access commonly used recruiting activities.

Video: [The PeopleSoft Fluid Recruiter Home and Hiring Manager Navigation Collection](#)

---

**Note:** Only users with the following roles will have access to the Fluid Recruiting Homepage: Recruiter Fluid, Recruiting Manager Fluid, and Recruitment Administrator Fluid.

These roles do not replace the classic Recruiter, Recruiting Manager and Recruitment Administrator Roles. The fluid roles should be added in addition to the existing recruiting roles for access to the Fluid Recruiting Homepage.

---

For general information about fluid pages in PeopleSoft HCM, see “Understanding PeopleSoft Fluid User Interface Homepages” (Application Fundamentals).

The Fluid Recruiting Homepage is automatically delivered to recruiting users with the fluid recruiting roles. The default homepage title appears at the top of the homepage when you first sign in. If the Recruiting homepage is not your default homepage, tap the title of the default homepage and select Recruiting from the list that appears.

# Recruiting Homepage

This example illustrates the Fluid Recruiting Homepage.

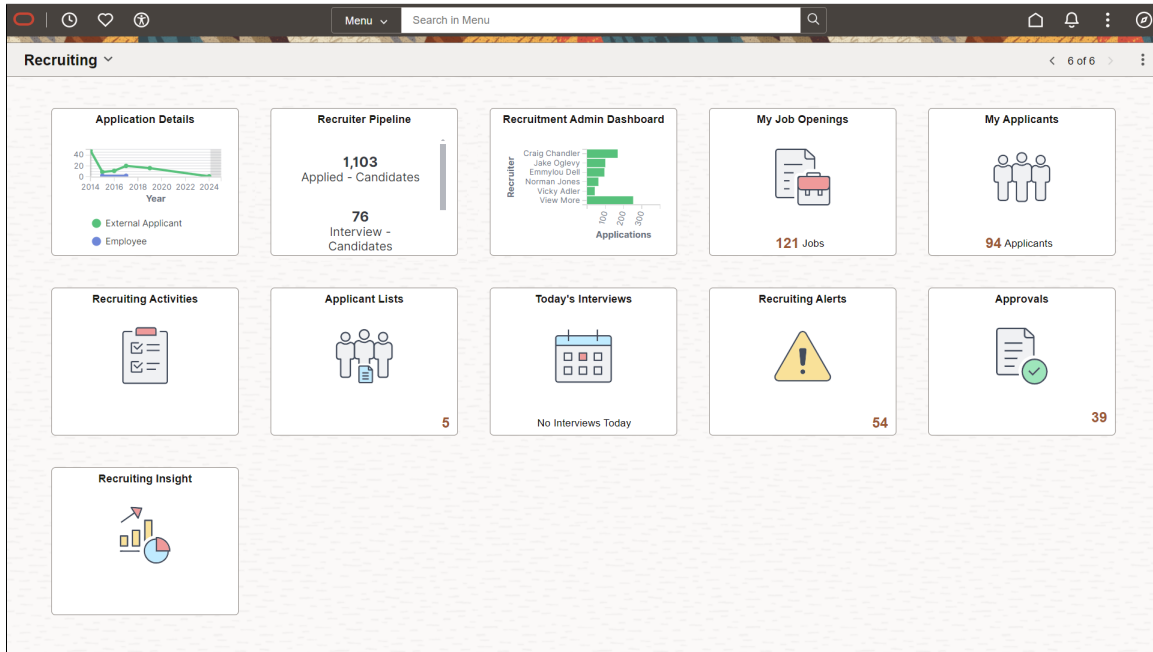

<b><i>Title Name</i></b>	<b><i>Description</i></b>
<u>Application Details Tile</u>	View visual charts of different aspects of application details.
“Insights Catalog Tile (and Navigation Collection)” (Application Fundamentals)	Access a collection of HCM Insights dashboards.
<u>My Job Openings Tile</u>	View the count of open jobs associated with the recruiting user, and access information about the job openings using the <u>My Job Openings Page</u> .
<u>My Applicants Tile</u>	View the count of applicants the recruiting user has and access information about the applicants on the <u>My Applicants Page</u> .
<u>Recruiting Activities Tile</u>	Access the <u>Recruiting Activities Page</u> to view a navigation collection of commonly used recruiting activities.
<u>Applicant Lists Tile</u>	View the count of private lists owned by the recruiting user, as well as the active public lists, and access the <u>My Applicant Lists Page</u> .

<b><i>Tile Name</i></b>	<b><i>Description</i></b>
<u>Today's Interviews Tile</u>	View the number of interviews the recruiting user has scheduled for the current day and access the <a href="#">My Interviews Page</a> .
Approvals Tile	Access the Approvals pages: <a href="#">Pending Approvals – Job Offer Page</a> and <a href="#">Pending Approvals – Job Opening Page</a> , and take action on pending approvals related to recruiting activities, like job offer, job openings, using Fluid Approvals.
<u>Recruiting Alerts Tile</u>	View the total count of alerts associated with the recruiting user's job openings and access the <a href="#">Recruiting Alerts Page</a> .
<u>Recruiting Insight Tile</u>	Access the Recruiting Insight dashboard and various pivot grids that provide graphic views of important performance measures.
<u>Recruiting Manager Summary Tile</u>	<p><b>Note:</b> This tile is available only for users with the Recruiting Manager Fluid role.</p> <hr/> <p>Access the <a href="#">Recruiting Manager Summary Page</a> to view summary information about the workload and effectiveness of recruiters who report to the current user.</p>

---

## Using the PeopleSoft Fluid User Interface to View My Job Openings

This topic discusses how Recruiters, Recruiting Managers and Recruiting Administrators use the fluid My Job Openings page to view information about job openings.

For general information about fluid pages in PeopleSoft HCM, see “Understanding PeopleSoft Fluid User Interface Homepages” (Application Fundamentals).

## Pages Used to View My Job Openings Using the PeopleSoft Fluid User Interface

<b>Page Name</b>	<b>Definition Name</b>	<b>Usage</b>
<u><a href="#">My Job Openings Tile</a></u>	HC_PE_MY_JOBS_FLU (cref for the tile) HRS_MYJOB_TILE_FLU (page for dynamic data)	View the count of open jobs for the recruiting user. Click this tile to access the My Job Openings page.
<u><a href="#">My Job Openings Page</a></u>	HRS_PE_MY_JOBS_FLU	View a list of job openings for the recruiting user.

### My Job Openings Tile

Use the My Job Openings tile (cref for the tile: HC\_PE\_MY\_JOBS\_FLU) to view the count of open jobs for the recruiting user.

Navigation:

The My Job Openings tile is on the delivered Fluid Recruiting Homepage.

This example illustrates the My Job Openings tile.



The count on the tile indicates the number of jobs for the recruiting user.

Click the tile to access a list of the job openings.

### My Job Openings Page

Use the My Job Openings page (HRS\_PE\_MY\_JOBS\_FLU) to view a list of job openings for the recruiting user.

Navigation:

Click the My Job Openings tile on the delivered Fluid Recruiting Homepage.

This example illustrates the My Job Openings page.

The screenshot displays the 'My Job Openings' page. On the left, there is a navigation pane with filters for 'Aspen (106)', 'Delaware Operations (63)', 'Swish Foundation National Ofc (43)', 'New York (37)', 'National Office (30)', 'Swish Fnd. North Cal Fed Rec (27)', 'California Location (26)', and 'New Orleans (23)'. Below this are filters for 'Status' (010 Open (859), 005 Draft (8855), 120 Canceled (130), 008 Pending Approval (116), 110 Filled/Closed (66), 100 Hold (39)) and 'Created In' (2004 (461), 2009 (111), 2006 (70), 2014 (69), 2012 (61), 2017 (42), 2015 (36), 2011 (32)).

The main area features a 'Quick Search' bar with the text 'Search My Job Openings' and a search input field. Below the search bar, it indicates '959 matching jobs found. Only the first 300 results can be displayed.' A table lists job openings with columns: Job Title/Job ID, Recruiting Location, Department, Category, Hiring Manager, Days Open, No Action Taken, Applicants, and Hot Job. The table contains several rows, including 'Director of Personnel', 'Supervisory Personnel Manageme', 'Director of Finance', 'Administrative Assistant-Hot Job', 'Management - Staff Assistant- Hot Job', 'Eben Director', and 'Supervisory Personnel Manageme'.

On the right, there is a 'Related Information' panel with sections: 'In Process Applications' (New 13.36%, Applied 152), 'Job Opening Aging' (Bar chart showing openings by age band), 'Jobs Opened/Closed' (Line chart showing status over time), and 'Time to Fill Jobs'.

## Left Panel

The left panel lists different facet filters to refine the job openings associated with the Recruitment/Hiring team. Available filters are:

- **My Association:** The available filters based on for your association with the job opening are: Created By Me, Hiring Manager, Primary Hiring Manager, Recruiter, Primary Recruiter, and Team Member. Team members include approvers as well as the members of the job opening hiring team. The Hiring Manager filter shows job openings where you are the primary or non-primary hiring manager. Similarly, the Recruiter filter shows job openings where you are the primary or non-primary hiring manager.
- **Department:** Use this facet to filter based on the job opening's department.
- **Hiring Manager:** Use this facet to filter based on the job opening's primary hiring manager. Non-primary hiring managers are not considered.
- **Recruiter:** Use this facet to filter based on the job opening's primary recruiter. Non-primary recruiters are not considered.
- **Job Family:** This facet offers hierarchical filtering based first on job family and then, after you select a job family, based on the job codes that are associated with the selected job family.
- **Location:** Use this facet to filter based on the job opening's location.
- **Status:** Use this facet to filter based on the job opening status.
- **Created In:** This facet offers hierarchical filtering based first on the year that the job opening was created and then, after you select a year, based on the month that the job opening was created.

Select the required filter criteria and search for the job opening.

## Quick Search

<i>Field or Control</i>	<i>Description</i>
<b>Search My Job Openings</b>	Enter a job title, location or any specific keyword and click the Search button to perform searches.
<b>Clear Search</b>	Click to clear the previous search results.
<b>Save Search</b>	Click this button to save the search criteria.
<b>My Saved Searches</b>	Click this button to view, delete, or run saved searches.

**Note:** If no personalizations are defined, then the job openings are listed based on the My Job Openings settings in Recruiting Installation - Jobs page. For details, see [Setting Up Recruiting Installation Settings](#).

## My Saved Searches

Use the My Saved Searches modal window to view, delete or run the saved searches. This modal window lists the existing saved searches. Saving enables users to rerun the searches without having to re-enter keywords and reselect filters.

This example illustrates My Saved Searches modal.

Cancel
**My Saved Searches**
Save

The Search button performs the search and shows your results on the My Job Openings page.

**My Saved Searches**

Preferred	Search Name		
<input checked="" type="checkbox"/>	DEFAULT	<span>Run Search</span>	
<input type="checkbox"/>	EVENT	<span>Run Search</span>	

Default search is the personalized search criteria definitions carried forward from previous versions of My Job Openings page saved by the user. By default, the system displays the list of job openings based on this default search definition for customers migrating to the latest release from a previous version.

<b>Field or Control</b>	<b>Description</b>
<b>Preferred</b>	Select this checkbox for the most frequently used search. If this checkbox is selected, the system executes the preferred saved search every time a user logs in. This overrides the default search definition carried forward from previous versions.
<b>Search Name</b>	Displays the unique search name entered by the user.
<b>Run Search</b>	Click this button to run the search and view results on the My Job Openings page.

## Actions

The Actions button displays a set of related actions that the user can choose to perform on all the job openings that are selected using the check box under Job Title/Job ID. These are the available options:

<b>Field or Control</b>	<b>Description</b>
<b>Add Job Note</b>	This is available for jobs of all statuses. Use the Add Job Note option to add a comment or note to all the selected job openings.
<b>Delete</b>	This is available only for job openings with status as Draft. Use the Delete option to delete the selected draft job openings.
<b>Cancel</b>	This is available only for job openings with status as Open. Use the Cancel option to cancel the selected job openings.
<b>Close</b>	This is available only for job openings with status as Open. Use the Cancel option to close the selected job openings.
<b>Hold</b>	This is available only for job openings with status as Open. Use the Hold option to put the selected job openings on hold.
<b>Approve</b>	This is available only for job openings with status as Pending or Denied. Use the Approve option to approve the selected job openings.
<b>Deny</b>	This is available only for job openings with status as Pending or Denied. Use the Deny option to reject the approval of the selected job openings.

<b>Field or Control</b>	<b>Description</b>
<b>Pushback</b>	This is available only for job openings with status as Pending or Denied. Use the Approve option to push back the approval of the selected job openings.

## My Job Openings

This grid displays all job openings for the recruiting user that meet the filter criteria. By default, the My Job Openings list displays the recent Job IDs at the top of the list, except for hot jobs. When there are hot jobs in the list, they are always displayed at the top.

<b>Field or Control</b>	<b>Description</b>
 <b>Sort button</b>	Use this button to sort job openings based on <i>Job Title</i> , <i>Job ID</i> (the default value), <i>Recruiting Location</i> , <i>Category</i> , <i>Hiring Manager</i> , <i>Days Open</i> , <i>No Action Taken</i> and <i>Applicants</i> .
<b>Job Title/Job ID</b>	Displays the job opening's primary posting title and the Job Opening ID.
<b>Recruiting Location</b>	The location represents the job opening's recruiting location rather than its physical location. If a job opening has multiple recruiting locations, the primary location appears.
<b>Department</b>	This displays the department for the job opening.
<b>Category</b>	<p>If job categorization is enabled on the <a href="#">Recruiting Installation – Jobs Page</a>, this column displays the category for the job opening. Categories are a personal organizational tool, and your categorization is not visible to other users.</p> <p>You can click the Category icon to access the Job Categories modal window and select your categories from there. You can also personalize your job category sort order, status and description by clicking the Personalize Job Categories link in this modal window.</p>
<b>Hiring Manager or Recruiter</b>	This column displays either the job opening's primary hiring manager or the job opening's primary recruiter, depending on the roles assigned to the current user.



<b>Field or Control</b>	<b>Description</b>
<b>Days Open</b>	For job openings in an open status, this column displays the number of days since the job opening’s earliest posting date. If the job has never been posted, this field displays the number of days since the job opening was created. If the earliest job posting date (or, if none, the job creation date) is in the future, the system displays 0.
<b>No Action Taken</b>	Displays the number of applicants in the Applied phase. Click this number to access the Manage Job Opening page pre-filtered to show only applicants in this phase.
<b>Applicants</b>	Displays the number of applicants in the Applied phase. To view these applicants, click the job opening to access the Manage Job Opening page, then click the <b>Applied</b> phase on the phase filter to show only applicants in the Applied phase.
 <b>Hot Job</b>	Displays the hot job icon for any jobs that are hot jobs. This column is hidden entirely if none of the job openings are hot jobs.



<b>Field or Control</b>	<b>Description</b>
	Click the chevron icon to access the <a href="#">Manage Job Opening Page</a> .

### Related Content and Decision Support

If you use PeopleTools 8.55 or later, the My Job Openings page includes a supplementary panel that provides access to related information and Simplified Analytics.

For more information about Simplified Analytics, refer to the Simplified Analytics topics in the *PeopleTools: Pivot Grid* documentation.

<b>Field or Control</b>	<b>Description</b>
<b>Related Information</b>	The <b>Related Information</b> panel provides the user the ability to quickly view insights analytics and simplified analytics. The simplified analytical charts are discussed in detail in the topic: <a href="#">Viewing Recruiting Pivot Grids</a> and insights analytics are detailed in <a href="#">Viewing Recruiting Insights</a> .

<b>Field or Control</b>	<b>Description</b>
 (Personalize Related Content icon)	<p>This icon appears at the top of the Related Information tab. Click to open the Personalize Related Content page. This page lists the available related content so you can choose whether the Related Information tab shows or hides each item.</p>
	<p>This icon appears at the top of each individual item in the Related Information tab. Click to expand the item to open a modal dialog with a larger interactive version of the chart.</p>

## Additional Data on My Job Openings Page

The My Job Openings page includes additional columns that are delivered hidden. To display these additional columns, use PeopleTools Application Designer to modify the grid definition.

The additional hidden columns are:

- Job Opening Type
- Target Openings
- Department
- Status
- Desired Start Date
- Earliest Post Date
- Unpost Date
- Latest Post Date
- Projected Fill Date

---

**Note:** If all job openings shown in the My Job Openings page are continuous job openings, the Desired Start Date and Projected Fill Date columns are hidden even if you have modified the grid definition to show these columns.

---

## Related Links

[Image Highlights, PeopleSoft HCM Update Image 41: Recruiter Search Enhancements](#)

---

# Using the PeopleSoft Fluid User Interface to View My Applicants

This topic discusses how Recruiters, Recruiting Managers and Recruiting Administrators use the fluid My Applicants page to view information about applicants who are associated with their job openings. It also provides access to recruiting pivot grids that provide actionable operational analytics.

For general information about fluid pages in PeopleSoft HCM, see “Understanding PeopleSoft Fluid User Interface Homepages” (Application Fundamentals).

## Pages Used to View My Applicants Using the PeopleSoft Fluid User Interface

<i>Page Name</i>	<i>Definition Name</i>	<i>Usage</i>
<u>My Applicants Tile</u>	HC_HRS_PE_MY_APPS_FL (cref for the tile)  HRS_MYAPP_TILE_FLU (page for dynamic data)	View the number of applicants for the recruiting user.  Click this tile to access the My Applicants page.
<u>My Applicants Page</u>	HRS_PE_MY_APPS_FL	View applicants associated with the recruiting user’s job openings and to review key information about each applicant.

### My Applicants Tile

Use the My Applicants tile (cref for the tile: HC\_HRS\_PE\_MY\_APPS\_FL) to view the number of applicants for the recruiting user.

Navigation:

The My Applicants tile is on the delivered Fluid Recruiting Homepage.

This example illustrates the My Applicants tile.



The count on the tile indicates the number of applicants for the recruiting user.

Click the tile to access a list of the applicants.

### My Applicants Page

Use the My Applicants page (HRS\_PE\_MY\_APPS\_FL) to view applicants associated with the recruiting user’s job openings and to review key information about each applicant.

It enables the recruiting user to search, view applications and resumes, and email applicants from a single page. This page also allows the recruiting users to access applicant analytics.

Navigation:

Click the My Applicants tile on the delivered Fluid Recruiting Homepage.

This example illustrates the My Applicants page.

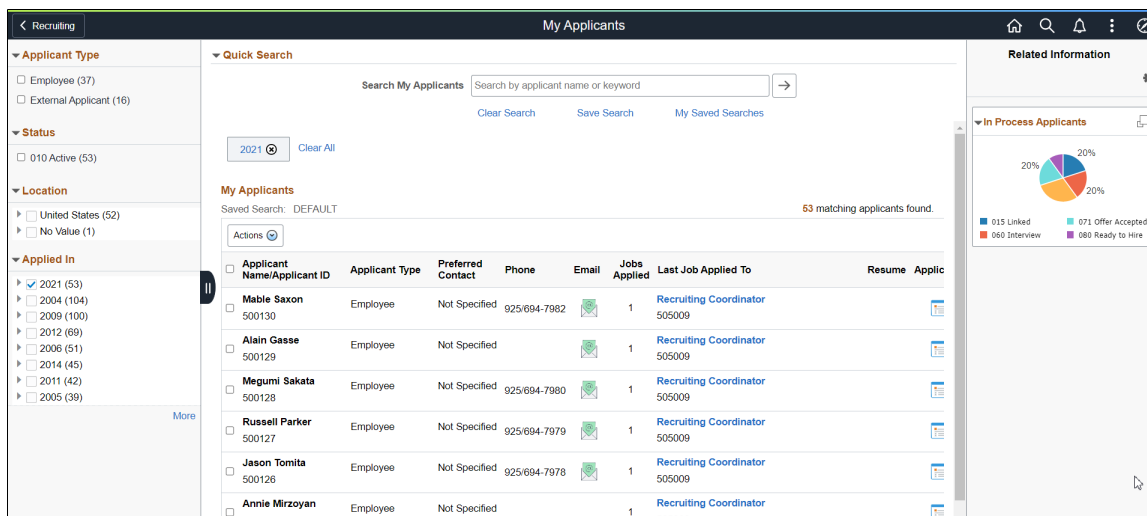

### Left Panel

The left panel lists different facet filters to refine the applicants associated with the Recruitment/Hiring team. Available filters are:

- Applicant Type: Use this facet to filter based on the applicant type: External Applicant, Employee, or Non-Employee.
- Status: Use this facet to filter based on the applicant status.
- Location: This facet offers hierarchical filtering based first on the applicant’s country, then state or province, then city.
- Applied in: This facet offers hierarchical filtering based first on the year that the application was created and then, after you select a year, based on the month that the application was created.

Select the required filter criteria and search for the applicant.

### Quick Search

<i>Field or Control</i>	<i>Description</i>
Search My Applicants	Use this field to search for applicants using name or other keywords, such as phone number, email id.

<b>Field or Control</b>	<b>Description</b>
<b>Clear Search</b>	Click this link to clear the search criteria and associated search results.
<b>Save Search</b>	Click this button to save the search criteria.
<b>My Saved Searches</b>	Click this button to view, delete, or run saved searches.

### My Saved Searches Modal

Use the My Saved Searches modal window to view, delete or run the saved searches.

My Saved Searches modal

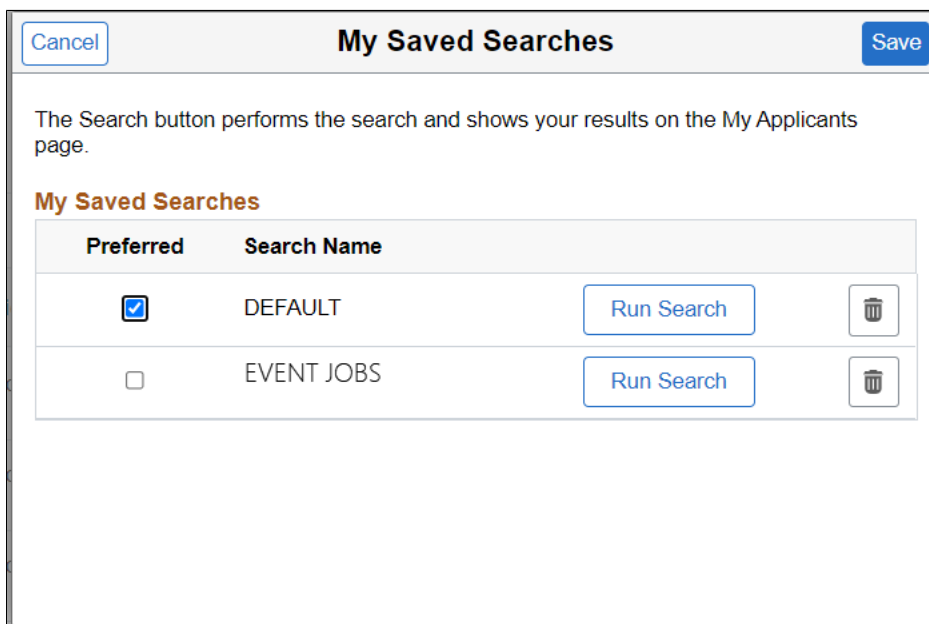

Default search is the personalized search criteria definition carried forward from the previous versions of My Applicants page saved by the user. By default, the system displays the list of applicants based on this default search definition for customers migrating to the latest release from a previous version.

<b>Field or Control</b>	<b>Description</b>
<b>Preferred</b>	Select this checkbox for most frequently used search. If this checkbox is selected, the system executes the preferred saved search every time a user logs in. This overrides the default search definition carried forward from previous version.
<b>Search Name</b>	Displays the unique search name entered by the applicant.

<b>Field or Control</b>	<b>Description</b>
<b>Run Search</b>	Click this button to run the search index and view results on the My Applicants page.

## Actions

The Actions button displays a set of related actions that the user can choose to perform on all the applicants that are selected using the check box under Applicant Name/Applicant ID. These are the available options:

<b>Field or Control</b>	<b>Description</b>
<b>Add Applicant to List</b>	Access the Add to Applicant List page where user can choose the List Name to add the applicants to.
<b>Change Applicant Status</b>	Change the overall status of the selected applicants.
<b>Forward Applicant</b>	Forward the information of the selected applicants to another person.
<b>Link Applicant to Job</b>	Link the selected applicants to one or more job openings.
<b>Send Correspondence</b>	E-mail letters related to job application status to the selected applicants.

## My Applicants

This grid displays all the applicants associated with the recruiting user's job openings, with the most recent applicants at the top of the list.

<b>Field or Control</b>	<b>Description</b>
 <b>Sort My Applicants</b> button.	Use this button to sort the applicants based on <i>Applicant Name</i> , <i>Applicant ID</i> (the default value), <i>Phone</i> , <i>Job Applied</i> and <i>Last Job Applied To</i> .
<b>Applicant Name/Applicant ID</b>	This field displays identifying information about the applicant.
<b>Applicant Type</b>	This field displays the type of applicant.

<b>Field or Control</b>	<b>Description</b>
<b>Preferred Contact</b>	Displays the contact preference to receive communication whether it is through email or phone.
<b>Phone</b>	Displays the applicant's primary phone number, if one exists.
<b>Email</b>	<p>The Email icon appears if the applicant record includes a primary email address. The system displays the actual email address as mouseover text for the icon.</p> <p>Click the icon to access the Send Correspondence Page to send email (or a letter) to the applicant. If a user does not have authorization for the Send Correspondence component, the user's default email client is opened instead.</p>
<b>Jobs Applied</b>	Displays the number of jobs for which the applicant has applications. All job openings are included, even if they are closed or if the user does not have security access to the opening. If the applicant applied more than once to the same job opening, that opening is counted only once. Applications not linked to a job opening are not included in the count, nor are unsubmitted (draft) applications.
<b>Last Job Applied To</b>	Displays the job opening ID and title for the applicant's most recent application. Click the link to access the Manage Job Opening page.
<b>Resume</b>	The Resume icon appears if the most recent application includes a resume. Click the icon to open the resume in a new window. If the resume is an attachment, the file opens in the new window. If the resume was entered as text in the application, the new window displays the Applicant Resume page in read-only mode. If none of the listed applicants have resumes, this column is hidden.
<b>Application</b>	Displays the Manage Application icon. Click the icon to access the Manage Application page, which provides a central location for performing all recruiting activities for a single job application.
<b>Print</b>	Click to access the Application Report Options Page, where you can choose report parameters and then generate an application details report.

## Included Applicants



The My Applicants page lists applicants who:

- Are associated with the user’s job openings (openings to which the user has security access).
- Are not in a Draft disposition (the disposition marked as Draft in your status configuration).
- Are not in a Reject disposition (any disposition associated with the Reject phase).

## Related Content and Decision Support

If you use PeopleTools 8.55 or later, the My Applicants page includes a supplementary panel that provides access to related information, Simplified Analytics and Insights visualizations.

For more information about Simplified Analytics, refer to the Simplified Analytics topics in the *PeopleTools: Pivot Grid* documentation.

<b>Field or Control</b>	<b>Description</b>
<b>Related Information</b>	The <b>Related Information</b> tab displays the In Process Applicants analytics.
 (Personalize Related Content icon)	This icon appears at the top of the Related Information tab. Click to open the Personalize Related Content page. This page lists the available related content so you can choose whether the Related Information tab shows or hides each item.
	This icon appears at the top of each individual item in the Related Information tab. Click to expand the item to open a modal dialog with a larger interactive version of the chart.

---

## Using the PeopleSoft Fluid User Interface to View Recruiting Activities

This topic discusses how Recruiters, Recruiting Managers and Recruiting Administrators use the Recruiting Activities tile on their Fluid Recruiting Homepage to access a navigation collection of commonly used recruiting activities.

Hiring Managers also have access to a Recruiting Activities tile on the Fluid Manager Self Service Homepage to access a navigation collection of recruiting activities, specific to their role.

Video: [The PeopleSoft Fluid Recruiter Home and Hiring Manager Navigation Collection](#)

For general information about fluid pages in PeopleSoft HCM, see “Understanding PeopleSoft Fluid User Interface Homepages” (Application Fundamentals).



## Pages Used to View Recruiting Activities Using the PeopleSoft Fluid User Interface

<b><i>Page Name</i></b>	<b><i>Definition Name</i></b>	<b><i>Usage</i></b>
<a href="#"><u>Recruiting Activities Tile</u></a>	HC_HRS_REC_ACTV_FL (cref for the tile)	Click this tile to access the Recruiting Activities page.
<a href="#"><u>Recruiting Activities Page</u></a>		View a navigation collection of commonly used recruiting pages.
<a href="#"><u>Search Applicants Page</u></a>	HRS_REC_SCHAPP	Search for applicants and perform applicant-related actions.
<a href="#"><u>Search Applications Page</u></a>	HRS_REC_SCHAPPL	Search recruiting records based on a combination of applicant and job opening criteria. Within the search results, you can perform recruiting actions or applicant actions.
<a href="#"><u>Search Job Openings Page</u></a>	HRS_JO_FIND_JOB	Search for job openings using a simple database search.
<a href="#"><u>Create Applicant Page</u></a>	HRS_ADD_APPLICANT	Create a new applicant record.
<a href="#"><u>Create Job Opening: Primary Job Opening Information Page</u></a>	HRS_JO_LAUNCH	Enter primary job opening information.
<a href="#"><u>Applicant Lists Page</u></a>	HRS_APPL_LIST	View existing applicant lists.
<a href="#"><u>Interview Calendar Page</u></a>	HRS_INT_CLNDR	See a weekly schedule of your own interviews.
<a href="#"><u>Saved Searches Page</u></a>	HRS_REC_SEARCHES	Review saved searches, and either run them or review the results, depending whether the criteria or results were saved.
<a href="#"><u>Recruiting Question Definition Page</u></a>	HRS_QSTN_DEF	Set up question definitions.
<a href="#"><u>Recruiting Answer Definition Page</u></a>	HRS_ANSWER_DEF	Set up answer definitions.
<a href="#"><u>Recruiting Question Set Page</u></a>	HRS_QSTN_SET_DEF	Set up question set definitions.

## Recruiting Activities Tile

Use the Recruiting Activities tile (cref for the tile: HC\_HRS\_REC\_ACTV\_FL) to access the Recruiting Activities page.

Navigation:

The Recruiting Activities tile is on the delivered Fluid Recruiting Homepage.

This example illustrates the Recruiting Activities tile.



## Recruiting Activities Page

Recruiters, Recruiting Managers and Recruiting Administrators use the Recruiting Activities page to view a navigation collection of commonly used recruiting pages, such as, Search, Create, Applicant Lists, Interview Calendar, and Saved Searches.

Navigation:

Click the Recruiting Activities tile on the delivered Fluid Recruiting Homepage.

This example illustrates the Recruiting Activities page.

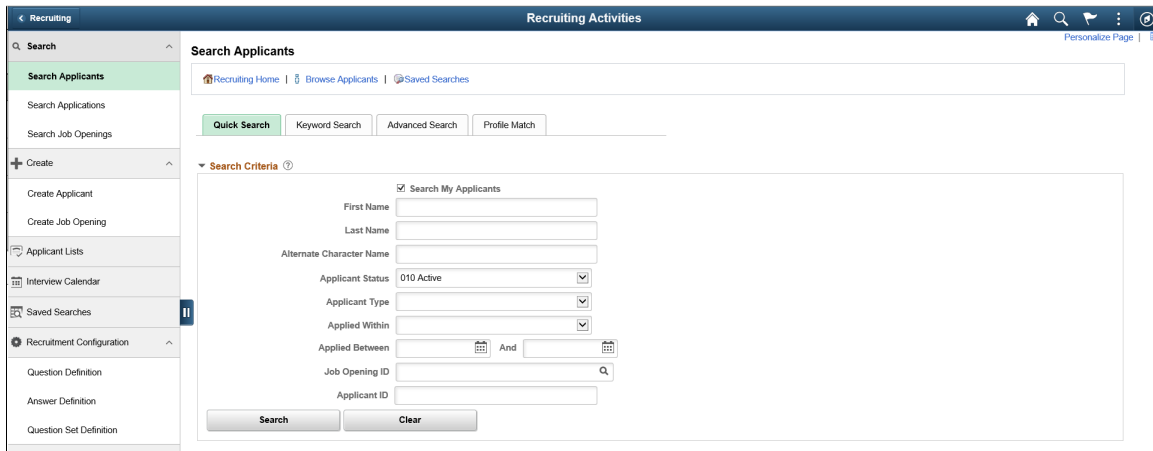

The navigation collection in the Recruiting Activities page, enables recruiting users to access frequently used Recruiting components from one location. The left panel of this page lists the components collected under six categories:

- Search category, with specific pages to search for applicants, applications and job openings.
- Create category, with specific pages to create applicants and job openings.
- Applicant Lists
- Interview Calendar
- Saved Searches
- Recruitment Configuration category, with specific pages to create definitions for questions, answers and question sets.

The right panel displays the component selected in the left panel.

### Recruiting Activities Navigation Collection for Hiring Managers

Hiring Managers also use the Recruiting Activities Navigation Collection to view the commonly used recruiting pages, specific to their role. For more details see [Using the PeopleSoft Fluid User Interface to View Recruiting Activities as a Hiring Manager](#).

---

## Using the PeopleSoft Fluid User Interface to View My Applicant Lists

This topic discusses how Recruiters, Recruiting Managers and Recruiting Administrators use the fluid My Applicant Lists page to view active applicant lists where the user is the list owner.

For general information about fluid pages in PeopleSoft HCM, see “Understanding PeopleSoft Fluid User Interface Homepages” (Application Fundamentals).

### Pages Used to View Applicant Lists Using the PeopleSoft Fluid User Interface

<i>Page Name</i>	<i>Definition Name</i>	<i>Usage</i>
<a href="#">Applicant Lists Tile</a>	HC_HRS_APPL_LIST_TILE_GBL (cref for the tile)  HRS_APPL_LIST (page for dynamic data)	The tile count indicates the number of private lists owned by the recruiting user, as well as the number of active public lists.  Click this tile to access the My Applicant Lists page.
<a href="#">My Applicant Lists Page</a>	HRS_APPL_LIST	Lists the private lists owned by the recruiting user, as well as the active public lists.

## Applicant Lists Tile

Use the Applicant Lists tile (HC\_HRS\_APPL\_LIST\_TILE\_GBL: cref for the tile) to view the count of private lists owned by the recruiting user, as well as the active public lists. The data on this tile comes from the HRS\_MAPLS\_TILE\_FLU page definition.

Navigation:

The Applicant Lists tile is on the delivered Fluid Recruiting Homepage.

This example illustrates the Applicant Lists tile.

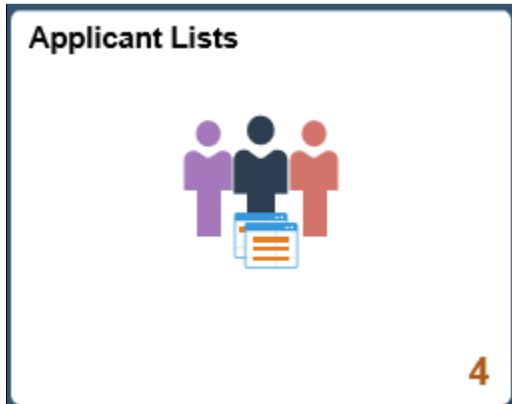

The count on the tile indicates the number of private lists owned by the recruiting user, as well as the number of active public lists.

Click the tile to access the applicant lists.

## My Applicant Lists Page

Use the My Applicant Lists page (HRS\_APPL\_LIST) to view all private lists owned by the recruiting user, as well as the active public lists.

Navigation:

Click the Applicant Lists tile on the delivered Fluid Recruiting Homepage.

This example illustrates the My Applicant Lists page.

 A screenshot of the "My Applicant Lists" page in a web browser. The page has a dark blue header with the title "My Applicant Lists" and navigation icons. Below the header, there is a search bar with "Find List" and a dropdown menu set to "Only My Lists", along with a green "Refresh" button. The main content area displays a table with the following data:
 

List	Description	Access	Date Created	Owner	
<a href="#">Excellent Applicants</a>	Sample Data Applicants	Public	2004-09-12	Betty Locherty	
<a href="#">Good Prospects</a>	Good Prospects Applicants List	Public	2004-07-26	Betty Locherty	
<a href="#">Inactive Applicants</a>	Inactive Applicants	Public	2005-11-28	Betty Locherty	
<a href="#">To Call List</a>	To Call List	Private	2004-07-26	Betty Locherty	

## Actions

From the My Applicant Lists page, the recruiting toolbar includes these page-specific actions.

<b>Field or Control</b>	<b>Description</b>
<b>Recruiting Home</b>	Click to go back to the Recruiting homepage.
<b>Search Applicants</b>	Click to access the Search Applicants page.
<b>Create New List</b>	Click to begin the process of creating a new applicant list.

## List Details

Click the list name in an applicant list row to access the [Managing Applicant Lists](#) page.

<b>Field or Control</b>	<b>Description</b>
<b>List</b>	Displays the list name. Click the list name to access the <a href="#">Managing Applicant Lists</a> page.
<b>Description</b>	Provides a description of the list.
<b>Access</b>	Indicates whether the list is <i>Private</i> or <i>Public</i> .
<b>Date Created</b>	Indicates the date on which the list was first created.
<b>Owner</b>	Displays the name of the list owner.
<b>View All</b>	Click to access the <a href="#">Applicant Lists Page</a> which displays all of the user's lists (along with other user's public lists).

---

## Using the PeopleSoft Fluid User Interface to View Interview Schedules

This topic discusses how Recruiters, Recruiting Managers and Recruiting Administrators use the fluid My Interviews page to view information about interview schedules.

For general information about fluid pages in PeopleSoft HCM, see “Understanding PeopleSoft Fluid User Interface Homepages” (Application Fundamentals).

## Pages Used to View Interview Schedules Using the PeopleSoft Fluid User Interface

<i>Page/Tile Name</i>	<i>Definition Name</i>	<i>Usage</i>
<u>Today's Interviews Tile</u>	HC_HRS_PE_MY_INTVW_FL_GBL (cref for the tile)  HRS_PE_MY_INTVW_FL (page for dynamic data)	View the number of interviews the recruiting user has scheduled for the current day.  Click this tile to access the My Interviews page.
<u>My Interviews Page</u>	HRS_MYINT_TILE_FL	View a list of all the interviews the recruiting user has scheduled for the current day.

### Today's Interviews Tile

Use the Today's Interviews tile (cref for the tile: HC\_HRS\_PE\_MY\_INTVW\_FL\_GBL) to view the number of interviews the recruiting user has scheduled for the current day. The data on this tile comes from the HRS\_PE\_MY\_INTVW\_FL page definition.

Navigation:

The Today's Interviews tile is on the delivered Fluid Recruiting Homepage.

This example illustrates the Today's Interviews tile.

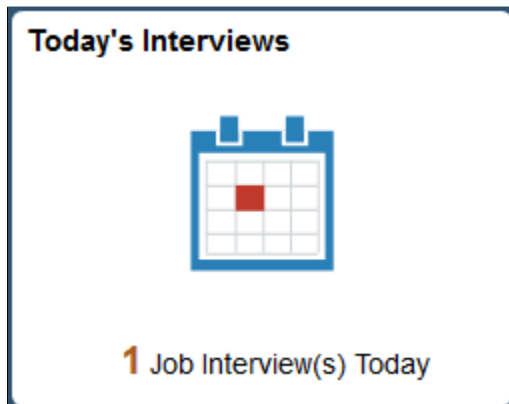

The count on the tile indicates the number of interviews the recruiting user has scheduled for the current day.

Click the tile to access a list of all the interviews the recruiting user has scheduled for the current day.

### My Interviews Page



Use the My Interviews page (HRS\_MYINT\_TILE\_FL) to view a list of interviews the recruiting user scheduled for the current day.

Navigation:

Click the Today’s Interviews tile on the delivered Fluid Recruiting Homepage.

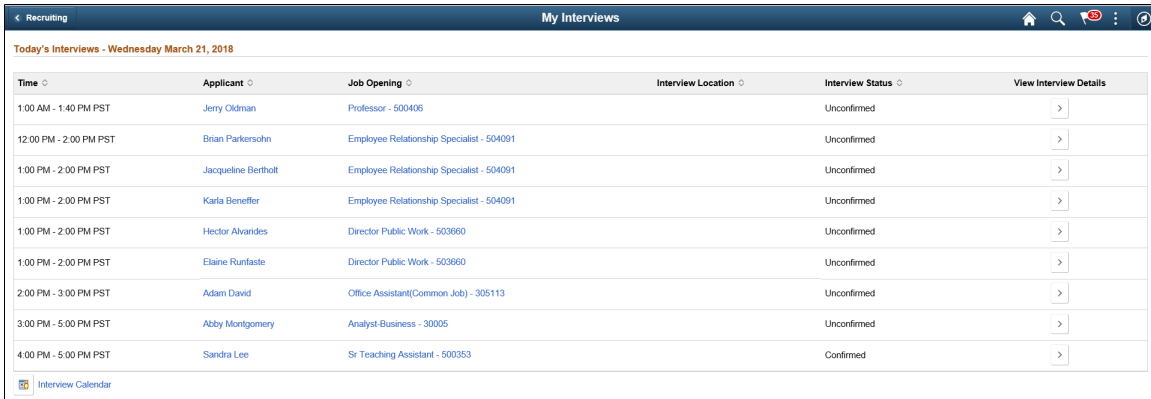
This example illustrates the My Interviews page.



<b>Field or Control</b>	<b>Description</b>
<b>Time</b>	Displays the start and end time of the interview in the recruiting user’s preferred time zone.
<b>Applicant</b>	Displays the name of the applicant to be interviewed. Click the name to access the <a href="#">Manage Applicant Page</a> .
<b>Job Opening</b>	Displays the Posting Title with the Job Opening ID of the Job Opening as a link. Click this link to access the <a href="#">Manage Job Opening Page</a> .
<b>Interview Location</b>	Displays the venue for the interview.  When the interview location displays a dotted underline, hover over the location, to view a pop up with details from the <a href="#">Interview Schedule Page</a> .
<b>Interview Status</b>	Displays the current status of the interview from the <a href="#">Interview Schedule Page</a> .
 <b>Chevron</b> button	Click the Chevron button to access the <a href="#">Interview Schedule Page</a> , to get additional details of the interview.
 <b>Interview Calendar</b> icon	Click to access the <a href="#">Interview Calendar Page</a> , which displays the recruiting user’s complete interview calendar.

If there are no interviews scheduled for the recruiting user, the following message is displayed: **'You have no interviews scheduled for today.'** An Interview Calendar icon is displayed, which directs the recruiting user to the [Interview Calendar Page](#).

## Using the PeopleSoft Fluid User Interface to View Recruiting Alerts

This topic discusses how Recruiters, Recruiting Managers and Recruiting Administrators use the fluid Recruiting Alerts page to view various types of alerts for the user's own job openings and to access pages with detailed information.

For general information about fluid pages in PeopleSoft HCM, see "Understanding PeopleSoft Fluid User Interface Homepages" (Application Fundamentals).

### Pages Used to View Recruiting Alerts Using the PeopleSoft Fluid User Interface

<b>Page Name</b>	<b>Definition Name</b>	<b>Usage</b>
<u>Recruiting Alerts Tile</u>	HC_HRS_PE_ALERTS_FL_GBL (cref for the tile)  HRS_PE_ALERTS_FL (page for dynamic data)	View the total count of alerts associated with the user's own job openings.  Click this tile to access the Recruiting Alerts page.
<u>Recruiting Alerts Page</u>	HRS_PE_ALERTS_FL	View summary information for the user's own job openings and to access pages with detailed information.
<u>Personalize Recruiting Alerts</u>	HRS_ALRT_PER_SCF	Select the alerts that you want to display on the Recruiting Alerts page and add filters for them.
<u>My Preferences Page</u>	HRS_USER_PREF_FL	Personalize recruiting alerts for hiring managers.

### Recruiting Alerts Tile

Use the Recruiting Alerts tile (cref for the tile: HC\_HRS\_PE\_ALERTS\_FL\_GBL) to view the total count of alerts associated with the user's own job openings. The data on this tile comes from the HRS\_PE\_ALERTS\_FL page definition.

Navigation:

The Recruiting Alerts tile is on the delivered Fluid Recruiting Homepage.



This example illustrates the Recruiting Alerts tile.



The number on the tile indicates the total count of the type of alerts enabled using the Personalize option.

Click the tile to access a list of the alerts set.

## Recruiting Alerts Page

Use the Recruiting Alerts page (HRS\_PE\_ALERTS\_FL) to view summary information for the user’s own job openings and to access pages with more detailed information.

**Note:** The alerts displayed on the My Alerts page relate only to the user’s own job openings. These are job openings where the user is on the hiring team.

Navigation:

Click the Recruiting Alerts tile on the delivered Fluid Recruiting Homepage.

This example illustrates the fields and controls for the Recruiting Alerts page.

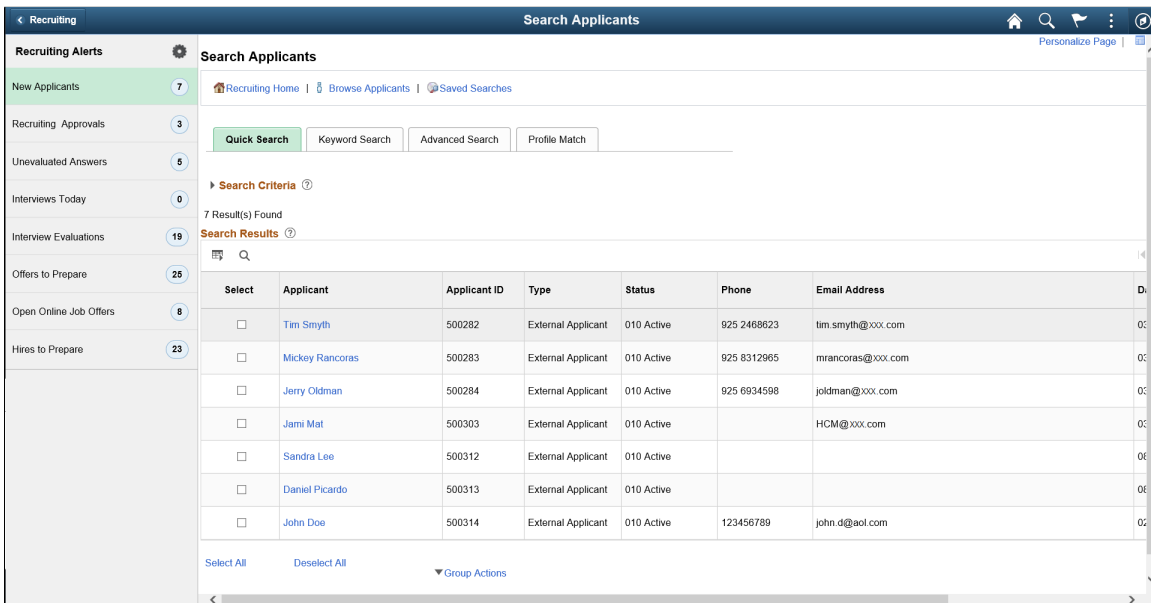

The left panel displays the alert type and the number of alerts. Click any alert type, to access the corresponding page for more details.

<b>Field or Control</b>	<b>Description</b>
The Personalize icon 	<p>Click to access the Personalize Recruiting Alerts page, and enable the type of alerts to display on the left panel of the Recruiting Alerts page.</p> <p>For more information, see the <i>Personalizing Recruiting Alerts</i> section below.</p>

<b>Alert Label</b>	<b>Description</b>	<b>Page Accessed</b>
<b>New Applicants &lt;count&gt;</b>	<p>Displays the number of new applicants that have applied to the recruiting user's job openings within the number of days specified on the Personalize Recruiting Alerts page.</p>	<p><a href="#">Search Applicants Page: Quick Search Tab</a></p> <p>When the recruiting user accesses the Search Applicants page from this link, it displays the applicants who have applied within the selected time frame.</p>
<b>Recruiting Approvals</b>	<p>Displays the combined number of job offers and job openings waiting for the recruiting user's approval.</p> <p>If approval authority is delegated to a proxy who has access to the Recruiting Alerts page, the delegated transactions are included in the proxy's count (and not the delegator's count) during the delegation period.</p>	<p><a href="#">Pending Approvals Page</a></p> <p>Use this page to review and act on the job offers and openings that require the recruiting user's approval.</p>
<b>Auto Match Results &lt;count&gt;</b>	<p>Displays the number of applicants in the search results for the user's saved Automatch searches. Search results exist only after the Run Automatch Search (HRS_AM) process has processed the automatch search.</p> <p>See <a href="#">Working With Saved Searches</a>.</p>	<p><a href="#">Saved Searches Page</a></p> <p>Use this page to view saved automatch searches and to access the associated search results.</p>
<b>Questionnaire Requests &lt;count&gt;</b>	<p>Displays the number of applicants who have not yet submitted updated applications for job openings with questionnaires after being invited to do so.</p> <p>Only applicants who are linked to currently open job openings are included.</p> <p>See <a href="#">Linking Applicants to Job Openings</a></p>	<p><a href="#">Questionnaire Requests Page</a></p> <p>Use this page to review open questionnaire requests and to send email reminders to selected applicants.</p>

<b>Alert Label</b>	<b>Description</b>	<b>Page Accessed</b>
<b>Unevaluated Answers &lt;count&gt;</b>	Displays the number of open-ended screening question evaluations that have not been completed for the user's job openings.	<a href="#">Unevaluated Answers Page</a> Use this page to see the applicants, job openings, and evaluators for the incomplete evaluations.
<b>Unconfirmed Interviews &lt;count&gt;</b>	Displays the number of unconfirmed interviews where the user is an interviewer.	<a href="#">Unconfirmed Interviews Page</a> Use this page to see the list of unconfirmed interviews.
<b>Interviews Today &lt;count&gt;</b>	Displays the number of interviews scheduled for the user on that specific day.	<a href="#">Interview Calendar Page</a> Use this page to review the recruiting user's weekly interview schedule.
<b>Interview Evaluations &lt;count&gt;</b>	Displays the number of incomplete interview evaluations where the user is the evaluator. Two types of evaluations are included in the count: <ul style="list-style-type: none"> <li>Evaluations that were saved as draft but not submitted.</li> <li>Evaluations that have not been started for an interview that has already occurred (based on the interview date).</li> </ul>	<a href="#">Interview Evaluations Page</a> Use this page to review and act on the incomplete evaluations.
<b>Job Offers to Approve &lt;count&gt;</b>	Displays the number of job offers waiting for the user's approval.  If approval authority is delegated to a proxy who has access to the Recruiting Alerts page, the delegated transactions are included in the proxy's count (and not the delegator's count) during the delegation period.	<a href="#">Pending Approvals Page</a> Use this page to review and act on the job offers that require the recruiting user's approval.
<b>Offers to Prepare &lt;count&gt;</b>	Displays the number of applications that: <ul style="list-style-type: none"> <li>Have a draft (unsubmitted) offer.</li> <li>Are in the Interview phase with an Interview status that is the designated "Complete" status. As delivered, the complete status for interviews is 020 Make Offer.</li> <li>Are in the Offer phase, but no offer record exists. This occurs only when a user manually changes an applicant's disposition using the Edit Disposition action.</li> </ul>	<a href="#">Offers to Prepare Page</a> Use this page to review applicants who are waiting for offers and to access the applicant or job opening so that the recruiting user can begin to prepare the offer.

<b><i>Alert Label</i></b>	<b><i>Description</i></b>	<b><i>Page Accessed</i></b>
<b>Open Online Job Offers &lt;count&gt;</b>	<p>Displays the number of expired or soon-to-expire open online job offers for your job openings. The number includes offers that will expire within the number of days that you specify on the Personalize Recruiting Alerts page.</p> <p>Open online job offers are offers that you posted to Candidate Gateway that have not been accepted or rejected. The offer status must be Extend.</p>	<p><a href="#">Open Online Job Offers Page</a></p> <p>Use this page to review the applicants and job openings associated with the open online job offers.</p>
<b>Hires to Prepare &lt;count&gt;</b>	<p>Displays the number of applicants with an Offer Accepted disposition for the user's job openings.</p> <hr/> <p><b>Note:</b> Keep the number of open items on this page to a minimum to improve the page performance.</p> <hr/>	<p><a href="#">Search Applications Page</a></p> <p>When the recruiting user accesses the Search Applications page from this link, it displays applications with the disposition Offer Accepted.</p>

## Personalize Recruiting Alerts

Click the Recruiting Alerts Personalize icon, on the left panel, to access the Personalize Recruiting Alerts page, where you can choose which alerts to display and to provide additional filtering criteria for certain alerts.

---

**Note:** An alert is shown in the left panel only if that alert type is enabled in the Personalize option.

---

This example illustrates the Personalize Recruiting Alerts page.

Cancel
**Personalize Recruiting Alerts**
Done

Specify the type of alerts you would like to be displayed.

New Applicants <input checked="" type="checkbox"/> Yes	*Applied Within <input type="text" value="070 - Last Year"/>
Recruiting Approvals <input checked="" type="checkbox"/> Yes	
Auto Match Results <input type="checkbox"/> No	*Created Within <input type="text" value="020 - Yesterday"/>
Questionnaire Requests <input type="checkbox"/> No	*Submitted Within <input type="text" value="020 - Yesterday"/>
Unevaluated Answers <input checked="" type="checkbox"/> Yes	*Created Within <input type="text" value="020 - Tomorrow"/>
Unconfirmed Interviews <input type="checkbox"/> No	*Submitted Within <input type="text" value="020 - Yesterday"/>
Interview Evaluations <input checked="" type="checkbox"/> Yes	
Interviews Today <input checked="" type="checkbox"/> Yes	Days Until Offer Expires <input type="text" value="0"/>
Offers to Prepare <input checked="" type="checkbox"/> Yes	
Open Online Job Offers <input checked="" type="checkbox"/> Yes	
Hires to Prepare <input checked="" type="checkbox"/> Yes	

<b>Field or Control</b>	<b>Description</b>
<Alert Name>	Select the alerts that you want to display on the Recruiting Alerts page.
<b>Applied Within</b> drop down	The New Applicants alert displays the number of applications that were submitted within the time period you select here. Options include <i>Today, Yesterday, Last 3 Days, Last Week, Last 2 Weeks, Last Month, Last Year, and View All.</i>
<b>Created Within</b> drop down	The Questionnaire Request alert and the Unconfirmed Interviews alert displays the number of questionnaire requests and unconfirmed interviews created within the time period you select here. Options include <i>Today, Yesterday, Last 3 Days, Last Week, Last 2 Weeks, Last Month, Last Year, and View All.</i>
<b>Submitted Within</b> drop down	The Unevaluated Answers alert and the Interview Evaluations alert displays the number of unevaluated answers and the interview evaluations submitted within the time period you select here. Options include <i>Today, Yesterday, Last 3 Days, Last Week, Last 2 Weeks, Last Month, Last Year, and View All.</i>
<b>Days Until Offer Expires</b> field	The Open Online Job Offers alert displays the number of open online job offers that will expire within the number of days that you enter here.

For more details, see the image highlights video on Recruiting Alerts

Video: [Image Highlights, PeopleSoft HCM Update Image 33: Recruiting Alerts Improvement](#)

## My Preferences Page

Use My Preferences for Recruiting (HRS\_USER\_PREF\_FL) to personalize recruiting alerts for hiring managers.

Navigation:

On the Manager Self-Service page, select Actions list on the header bar.

Select Recruiting from the left pane.

Personalize Recruiting Alerts for Hiring Managers

The options and the filters for the options are the same as for the Personalize Recruiting Alerts page. For more details, see [Personalize Recruiting Alerts](#)

---

## Taking Action on Pending Approvals Related to Recruiting Using Fluid Approvals

This topic describes how Recruiters, Recruiting Managers and Recruiting Administrators access and take actions on pending approvals related to recruiting activities, such as job offers and job openings, using Fluid Approvals.

---

**Note:** All recruiting users with the role “Approvals Fluid” can access the Approvals tile from the Fluid Recruiting Homepage.

---

See also “Using PeopleSoft Fluid User Interface Self-Service Approval Transactions” (Application Fundamentals).

## Pages Used to Take Action on Pending Approvals Related to Recruiting Using Fluid Approvals

<i>Page Name</i>	<i>Definition Name</i>	<i>Usage</i>
Approvals Tile	EOAWMA_USER_FL	Access and take action on pending approvals related to recruiting activities, like job offer, job openings, using Fluid Approvals.
<u>Pending Approvals Page – Job Offer Category</u>	EOAWMA_MAIN_FL	View and access the pending items for approval associated with the Job Offer category.
<u>Pending Approvals – Job Offer Page</u>	EOAWMA_TXNHDTL_FL	Take action on a pending job offer. You can either approve or deny the job offer, or push the item back to the requester.
<u>Pending Approvals Page – Job Opening Category</u>	EOAWMA_MAIN_FL	View and access the pending items for approval associated with the Job Opening category.
<u>Pending Approvals – Job Opening Page</u>	EOAWMA_TXNHDTL_FL	Take action on a pending job opening. You can either approve or deny creating a new job opening, or push the item back to the requester.

### Pending Approvals Page – Job Offer Category

Use the Pending Approvals page (EOAWMA\_MAIN\_FL) – Job Offer category to view and access the pending items for approval associated with the Job Offer Category.

Navigation:

Click the Approvals tile on the Fluid Recruiting Homepage, to access the Pending Approvals page. From the left panel, click the Job Offer category.

This example illustrates the fields and controls on the Pending Approvals Page – Job Offer Category. You can find definitions for the fields and controls later on this page.



<i>Field or Control</i>	<i>Description</i>
<b>Job Offer (count)</b>	The left panel, Job Offer category, displays a count of job offers, which are awaiting approval.

## Pending Approvals – Job Offer Page

Use the Pending Approvals (EOAWMA\_TXNHDTL\_FL) – Job Offer page to take action on a pending job offer. You can either approve or deny the job offer, or push the item back to the requester.

Navigation:

Click the Approvals tile on the Fluid Recruiting Homepage, to access the Pending Approvals page. From the left panel, click the Job Offer category and then click any row to navigate to the Job Offer page for that particular item.

This example illustrates the fields and controls on the Pending Approvals – Job Offer page. You can find definitions for the fields and controls later on this page.

The screenshot shows the 'Job Offer' page with the following details:

- Job Offer Information:**
  - Applicant: William Lucas
  - Job Posting Title: Event Coordinator (Core)-10249
  - Offer Date: 05/13/2009
  - Offer Expiration Date: 05/23/2009
  - Recruiter: Liz Zacharia
  - Applicant ID: 100224
  - Job Opening ID: 500389
  - Start Date:
  - Hiring Manager: George Simon
- Additional Information:**
  - Job Type: Standard Requisition
  - Job Family: RS Administrative Job Family - N30000
  - Company: Swiss Hotels - NSW
  - Job Code: Event Coordinator - N00011
  - Position Number:
  - Business Unit: Swiss Hotels - NSWBU
- Job Offer Component Table:**

Component	Frequency	Offer Amount	Payment Mode
Base Salary	Monthly	342,342.00 USD	Cash
- Controls:**
  - Buttons: Approve, Deny, Pushback
  - View Job Offer hyperlink
  - Approver Comments (text area)
  - Approval Chain (dropdown)

The approval options on this page are common to all fluid approval transactions, as described in the documentation for the “Using PeopleSoft Fluid User Interface Self-Service Approval Transactions” (Application Fundamentals).

<b>Field or Control</b>	<b>Description</b>
<b>Approve, Deny and Pushback buttons</b>	Use these buttons to take action on the requested approval.
<b>View Job Offer hyperlink</b>	Click this link to open the <b>Prepare Job Offer</b> page, where the details of the offer are displayed.
<b>Approver Comments</b>	Enter any comments related to the approval action you take.
<b>Approver Chain</b>	Click this item to open the <b>Approval Chain</b> page, where you can review information about all the approvers for the transaction.

## Pending Approvals Page – Job Opening Category

Use the Pending Approvals page (EOAWMA\_MAIN\_FL) – Job Opening category to view and access the pending items for approval associated with the Job Opening Category.



Navigation:

Click the Approvals tile on the Fluid Recruiting Homepage, to access the Pending Approvals page. From the left panel, click the Job Opening category.

This example illustrates the fields and controls on the Pending Approvals Page – Job Opening Category.



<b>Field or Control</b>	<b>Description</b>
<b>Job Opening (count)</b>	The left panel, Job Opening category, displays a count of job openings, which are awaiting approval.

## Pending Approvals – Job Opening Page

Use the Pending Approvals (EOAWMA\_TXNHDTL\_FL) – Job Opening page to take action on a pending job opening. You can either approve or deny creating a new job opening, or push the item back to the requester.

Navigation:

Click the Approvals tile on the Fluid Recruiting Homepage, to access the Pending Approvals page. From the left panel, click the Job Opening category and then click any row to navigate to the Job Opening page for that particular item.

This example illustrates the fields and controls on the Pending Approvals – Job Opening page.

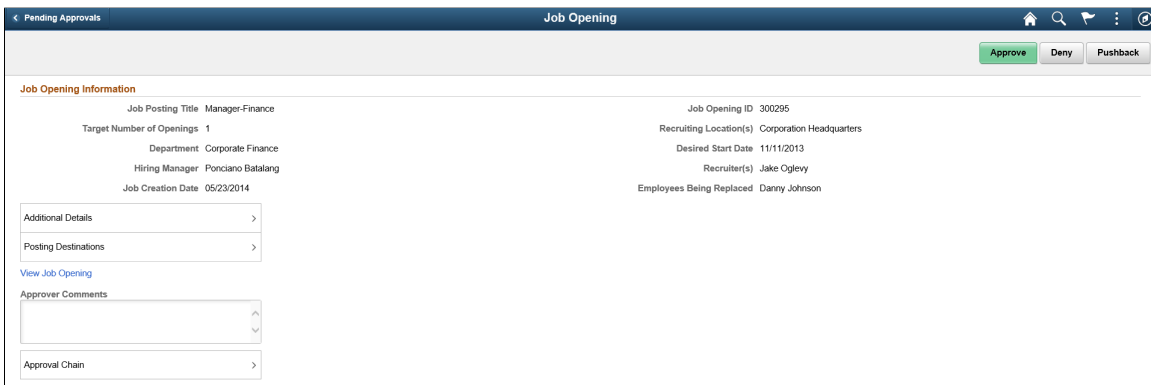

The approval options on this page are common to all fluid approval transactions, as described in the documentation for the “Using PeopleSoft Fluid User Interface Self-Service Approval Transactions” (Application Fundamentals).

<b>Field or Control</b>	<b>Description</b>
<b>Approve</b> , <b>Deny</b> and <b>Pushback</b> buttons	Use these buttons to take action on the requested approval.
<b>View Job Opening</b> hyperlink	Use this link to access the Manage Job Opening page.
<b>Additional Details</b>	Click this item to view additional details of the job opening.
<b>Posting Destinations</b>	Click this item to view details about the posting information for the job opening.
<b>Approver Comments</b>	Enter any comments related to the approval action you take.
<b>Approver Chain</b>	Click this item to open the <b>Approval Chain</b> page, where you can review information about all the approvers for the transaction.

## Using the PeopleSoft Fluid User Interface to View Recruiting Analytics

This topic discusses how recruiters, recruiting managers and recruiting administrators use the Recruiting Insight tile to access the Recruiting Insight home page to view the detailed recruiting analytics, such as pivot grids for Time to Fill Jobs, Job Opening Aging, In Process Applicants and Jobs Opened/Closed, and various Recruiting Insights Dashboards.

Users with the Recruitment Administrator role have access to two additional analytic tiles: Applicant Diversity tile and Applications Diversity tile.

For general information about fluid pages in PeopleSoft HCM, see “Understanding PeopleSoft Fluid User Interface Homepages” (Application Fundamentals).

For more information about Recruiting Pivot grids, see [Understanding Recruiting Pivot Grids](#) and [Understanding Diversity Analytics](#).

## Pages Used to View Recruiting Analytics Using the PeopleSoft Fluid User Interface

<b>Page Name</b>	<b>Definition Name</b>	<b>Usage</b>
<a href="#">Recruiting Insight Tile</a>	HC_HRS_MY_ANALYTICS_FL_LINK (cref for the tile)	Access the Recruiting Insight home page, with various dynamic tiles showing different analytic charts.
<a href="#">Application Details Tile</a>	HC_HRS_APPLICATION_DBRD_FL (cref for the tile)	Access the Application Details Insights dashboard.

<b>Page Name</b>	<b>Definition Name</b>	<b>Usage</b>
<u>Recruiter Pipeline Tile</u>	HC_HRS_RECRUITER_DBRD_FL (cref for the tile)	Access the Recruiter Pipeline Insights dashboard.
<u>Recruitment Admin Dashboard Tile</u>	HC_HRS_RECRUITMENT_ADM_DBRD_FL (cref for the tile)	Access the Recruitment Admin Dashboard.
<u>Time to Fill Jobs Tile</u> <u>Time to Fill Jobs Pivot Grid</u>	HC_HRS_PG_TTF_MY_ANALYTICS_FL (cref for the tile)	View a bar graph showing the user's average number of days to fill a job opening for a specified time period.
<u>Job Opening Aging Tile</u> <u>Job Opening Aging Pivot Grid</u>	HC_HRS_PG_J_AG_MY_ANALYTICS_FL (cref for the tile)	View a chart showing data for job openings based on the user's security access.
<u>In Process Applicants Tile</u> <u>In Process Applicants Pivot Grid</u>	HC_HRS_PG_APP_MY_ANALYTICS_FL (cref for the tile)	View the distribution of dispositions for applicants who are being considered for job openings, based on the user's security access.
<u>Jobs Opened/Closed Tile</u> <u>Jobs Opened/Closed Pivot Grid</u>	HC_HRS_PG_JO_OC_FL (cref for the tile)	View the number of job openings that were opened and closed each month, based on the user's security access.
<u>Applicant Diversity Tile</u> <u>Applicant Diversity Pivot Grid</u>	HC_HRS_PG_DIV_OV_FL	View diversity data by applicant.
<u>Applications Diversity Tile</u> <u>Applications Diversity Pivot Grid</u>	HC_HRS_PG_DA_APPLN_FL	View diversity data by application.

## Understanding Recruiting Pivot Grids

PeopleSoft Pivot Grid is a PeopleTools technology that provides operational analytics using charts and grids. Pivot grids enable users to visually display real-time data and organize it on the fly by pivoting and filtering. The self-service, multi-dimensional analytics provided by PeopleSoft Pivot Grid provides users with the business intelligence needed to make informed decisions.

Recruiting Solutions delivers four pivot grids that provide graphic views of important performance measures:

- **Job Opened/Closed** chart shows data related to the number of openings that are opened and closed on a monthly basis, giving users a picture of hiring activity across time, departments and locations.
- The **Job Opening Aging Analysis** chart shows the number of open job openings in various pre-defined age bands, providing vital information about an organization's recruiting backlog.

- The **In Process Applicants** chart shows the distribution of dispositions for applicants who are being considered for job openings, offering a view of the applicant pipeline.
- The **Time to Fill Jobs** chart shows the monthly average Time to Fill data, helping users to see trends in their ability to fill job openings.

This data is available to Recruiters, Recruiting Managers and Recruiting Administrators also through various other recruiting tiles. Hiring Managers can access some of these analytics through the Recruiting Activities tile on the Manager Self Service.

For more information on the setup and capabilities of PeopleSoft Pivot Grid, see *PeopleTools: Pivot Grid*.

## Common Elements for Viewing Pivot Grids

These page controls appear on all Recruiting pivot grids:

<b>Field or Control</b>	<b>Description</b>
	<p>Click to open the Options Menu, then select from these menu items:</p> <ul style="list-style-type: none"> <li>• <b>View Grid:</b> Opens an modal window that displays the data in a grid format rather than a chart format.</li> <li>• <b>Update Filters:</b> Opens the Update Filters modal window, from where you can add or remove filters. When a filter is added, it is displayed as a facet in the left panel. The available facets include: Recruiter, Business Unit, Job Family, Department, etc.</li> <li>• <b>Chart Options:</b> Opens the Chart Options modal window, where you can change the chart labels, layout, axes, and filters.</li> <li>• <b>Export Data:</b> Exports the underlying PSQuery data to a spreadsheet.</li> <li>• <b>Reset:</b> Deletes all saved personalizations and resets to a default layout.</li> <li>• <b>Save:</b> Saves the current grid and chart layout as the default view.</li> <li>• <b>Save As:</b> Saves the current grid and chart layout with the name and title that you specify.</li> <li>• <b>Sort Option:</b> Enables you to sort data with some available parameters.</li> </ul>

<b>Field or Control</b>	<b>Description</b>
<Drilldown Menu>	<p>When you click a data element (for example, a bar on a bar chart), the <b>Actions</b> menu provides these options:</p> <ul style="list-style-type: none"> <li>• <b>Detailed View:</b> Displays a grid with the detailed data. For example, if a bar on a bar chart represents the number of job openings that were filled in a particular month, clicking Detailed View displays a grid with information about each of the included job openings.</li> <li>• <b>Drilldown To:</b> Displays the drilldown options defined for the chart. Clicking a drilldown option redraws the chart based on the selected type of data.</li> </ul>

## Recruiting Insight Tile

Use the Recruiting Insight tile (cref for the tile is HC\_HRS\_MY\_ANALYTICS\_FL\_LINK) to access the [Recruiting Insight Tile](#).

Navigation:

Access the Recruiting Insight tile from the Fluid Recruiting home page.

This example illustrates the Recruiting Insight tile.



## Recruiting Insight Home Page

Use the Recruiting Insight Home page to access the recruiting insights dashboards and pivot grids.

Navigation

**Recruiting > Recruiting Insight**

This example illustrates the fields and controls on the Recruiting Insight home page.

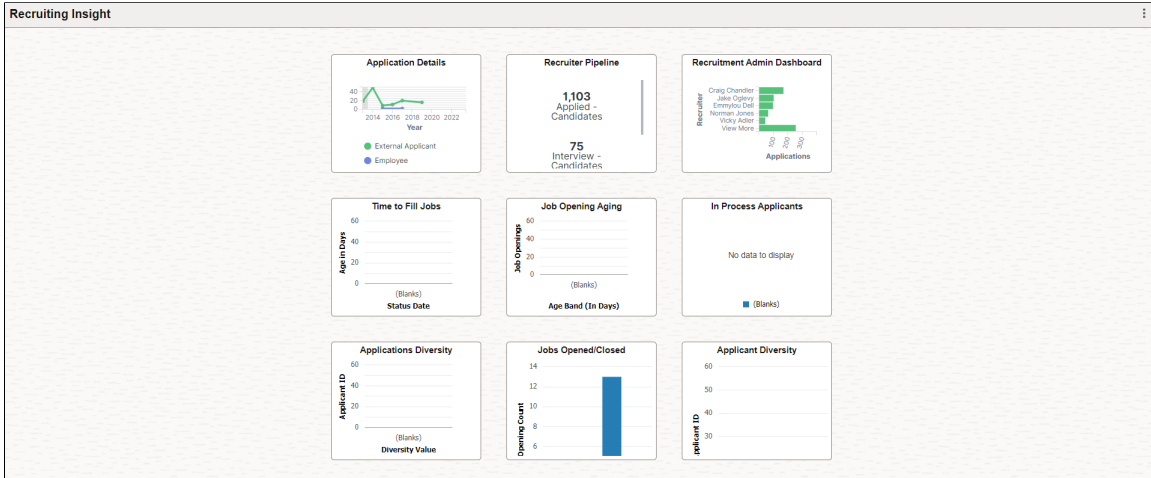

To know more on recruiting insight dashboards, see [Viewing Recruiting Insights](#).

## Application Details Tile

Use the Application Details tile (HC\_HRS\_APPLICATION\_DBRD\_FL) to access the Application Details dashboard and view different visualization on applicant details.

Navigation:

**Recruiting > Recruiting Insight > Application Details**

This example illustrates the fields and controls on the Application Details tile.



Click the tile to access the [Application Details Insights Dashboard](#).

## Recruiter Pipeline Tile

Use the Recruiter Pipeline tile to access the Recruiter Pipeline dashboard and gain insights into the job openings based on the logged in recruiter.

Navigation

**Recruiting > Recruiting Insight > Recruiter Pipeline**

This example illustrates the fields and controls on the Recruiter Pipeline tile.

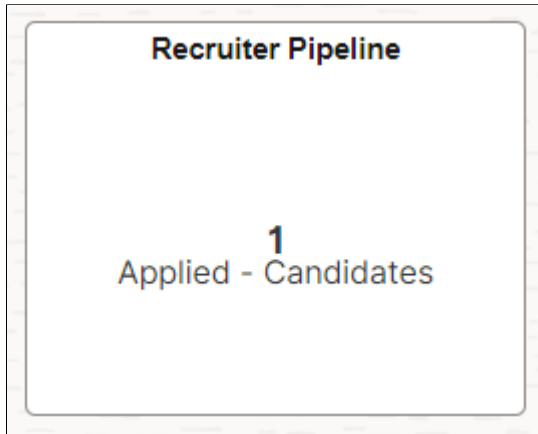

Click the tile to access the [Recruiter Pipeline Dashboard](#).

## Recruitment Admin Dashboard Tile

Use the Recruitment Admin Dashboard Tile to access the Recruitment Admin Dashboard and gain insights into the recruiter data.

Navigation

**Recruiting > Recruiting Insight > Recruitment Admin Dashboard**

This example illustrates the fields and controls on the Recruitment Admin Dashboard tile.

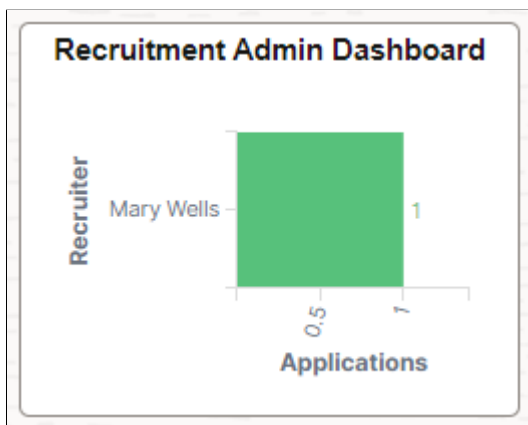

Click the tile to access the [Recruitment Admin Dashboard](#).

## Time to Fill Jobs Tile

Use the Time to Fill Jobs tile (cref for the tile is HC\_HRS\_PG\_TTF\_MY\_ANALYTICS\_FL) to view a bar graph showing the user's average number of days to fill a job opening for a specified time period.

Navigation:

Click the Recruiting Insight tile on Fluid Recruiting Homepage. The Time to Fill Jobs tile is on the Recruiting Insight home page.

This example illustrates the Time to Fill Jobs tile.

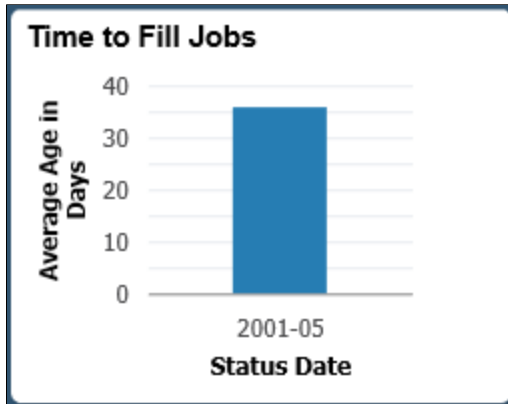

Click anywhere on the tile to access the Time to Fill Jobs pivot grid.

## Time to Fill Jobs Pivot Grid

Use the Time to Fill Jobs pivot grid to view the average number of days to fill job openings by month.

Navigation:

Click the Time to Fill Jobs tile on the Recruiting Insight home page.

This example illustrates the fields and controls on the Time to Fill Jobs pivot grid.

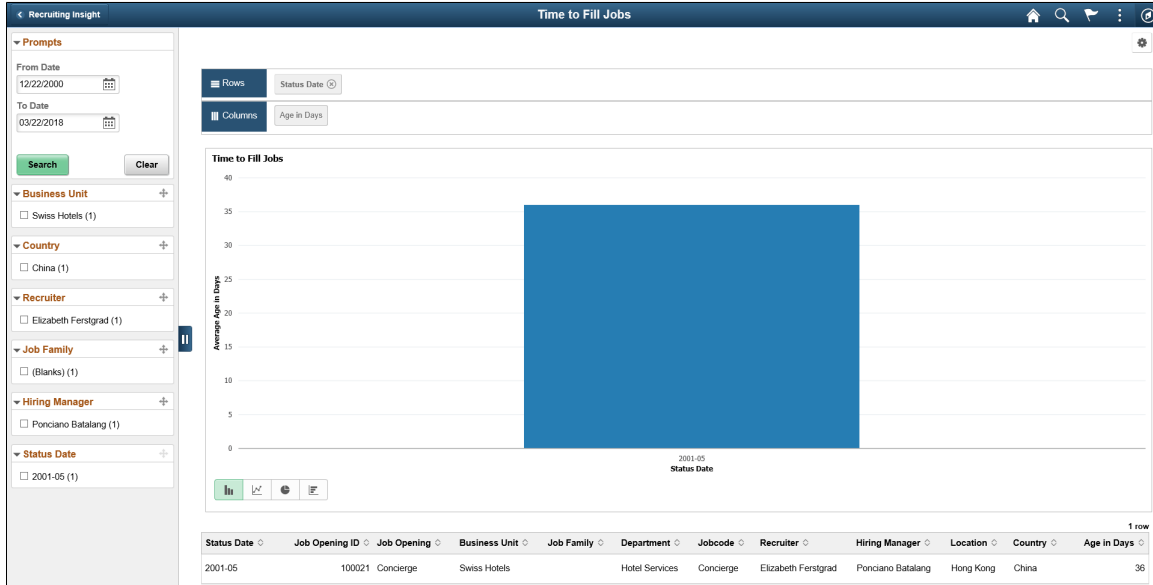

The Time to Fill pivot grid displays the average days taken to fill the job openings that are closed in a particular month.

The chart represents data for job openings to which the user has security access.



## Job Opening Aging Tile

Use the Job Opening Aging tile (cref for the tile is HC\_HRS\_PG\_J\_AG\_MY\_ANALYTICS\_FL) to view the number of open job openings of various ages.

Navigation:

Click the Recruiting Insight tile on Fluid Recruiting Homepage. The Job Opening Aging tile is on the Recruiting Insight home page.

This example illustrates the Job Opening Aging tile.

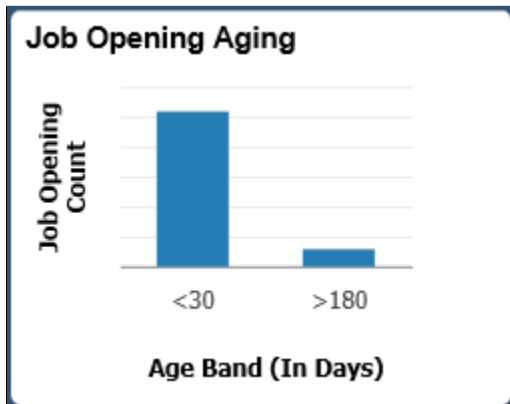

Click anywhere on the tile to access the Job Opening Aging pivot grid.

## Job Opening Aging Pivot Grid

Use the Job Opening Aging pivot grid to view the number of open job openings of various ages.

Navigation:

Click the Job Opening Aging tile on the Recruiting Insight home page.

This example illustrates the Job Opening Aging pivot grid.

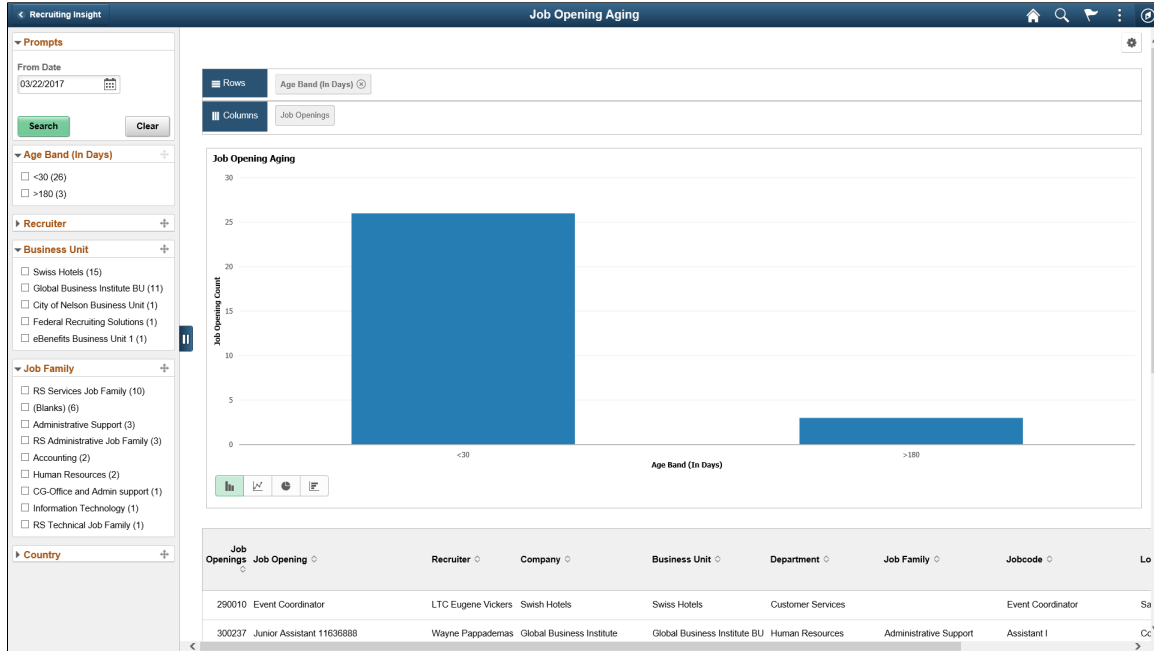

## In Process Applicants Tile

Use the In Process Applicants tile (cref for the tile is HC\_HRS\_PG\_APP\_MY\_ANALYTICS\_FL) to view the distribution of dispositions for applicants who are being considered for job openings.

Navigation:

Click the Recruiting Insight tile on Fluid Recruiting Homepage. The In Process Applicants tile is on the Recruiting Insight home page.

This example illustrates the In Process Applicants tile.

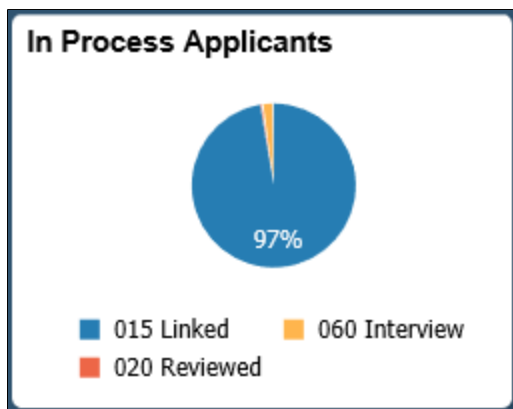

Click anywhere on the tile to access the In Process Applicants pivot grid.

## In Process Applicants Pivot Grid

Use the In Process Applicants pivot grid to view a bar graph showing the user’s average number of days to fill a job opening for a specified time period.

Navigation:

Click the In Process Applicants tile on the Recruiting Insight home page.

This example illustrates the In Process Applicants pivot grid.

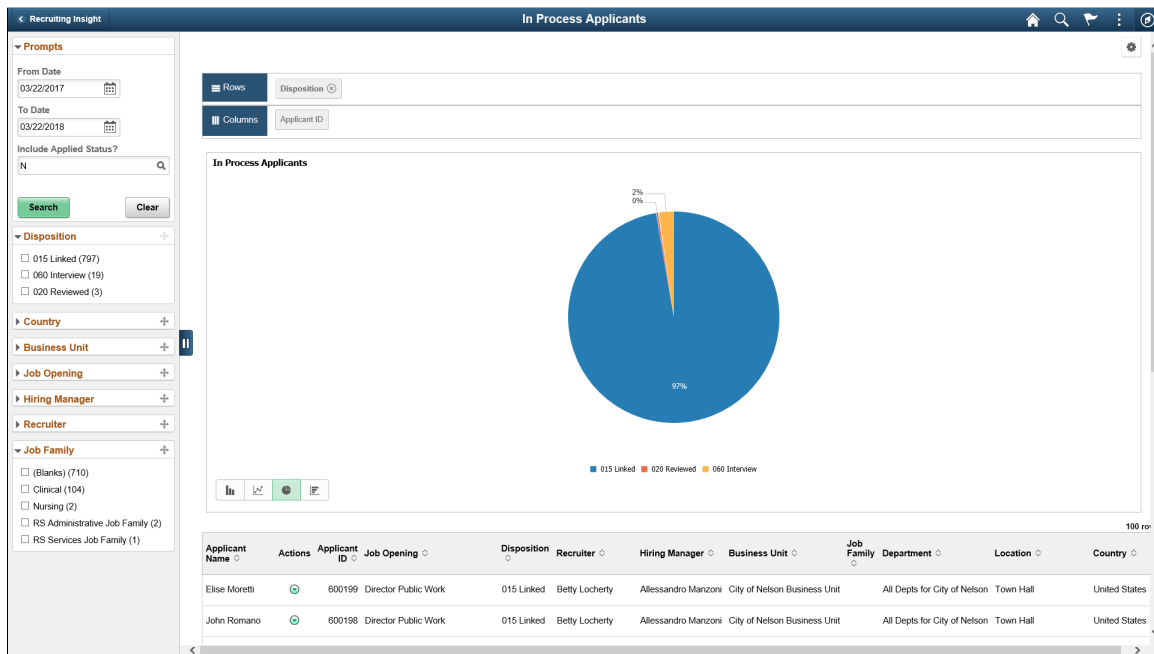

## Jobs Opened/Closed Tile

Use the Jobs Opened/Closed tile (cref for the tile is HC\_HRS\_PG\_JO\_OC\_FL) to view a bar graph showing the user’s average number of days to fill a job opening for a specified time period.

Navigation:

Click the Recruiting Insight tile on Fluid Recruiting Homepage. The Jobs Opened/Closed tile is on the Recruiting Insight home page.

This example illustrates the Jobs Opened/Closed tile.

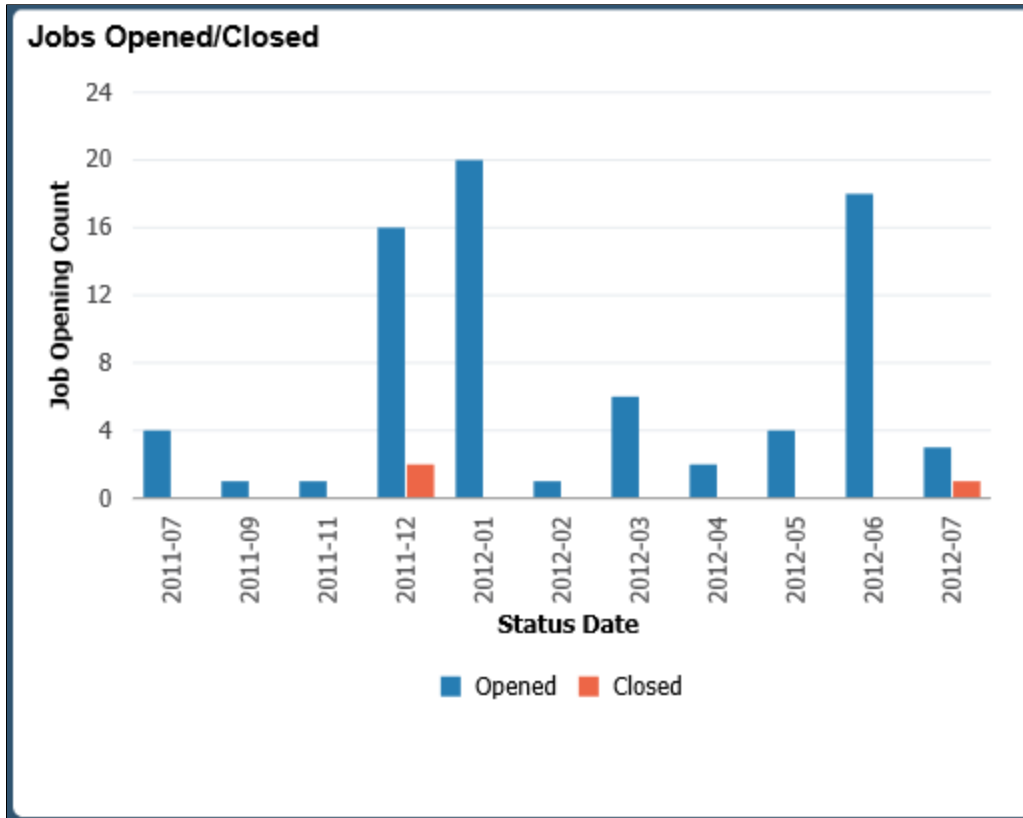

Click anywhere on the tile to access the Jobs Opened/Closed pivot grid.

## Jobs Opened/Closed Pivot Grid

Use the Jobs Opened/Closed pivot grid to view a bar graph showing the user's average number of days to fill a job opening for a specified time period.

Navigation:

Click the Jobs Opened/Closed tile on the Recruiting Insight home page.

This example illustrates the Jobs Opened/Closed pivot grid.

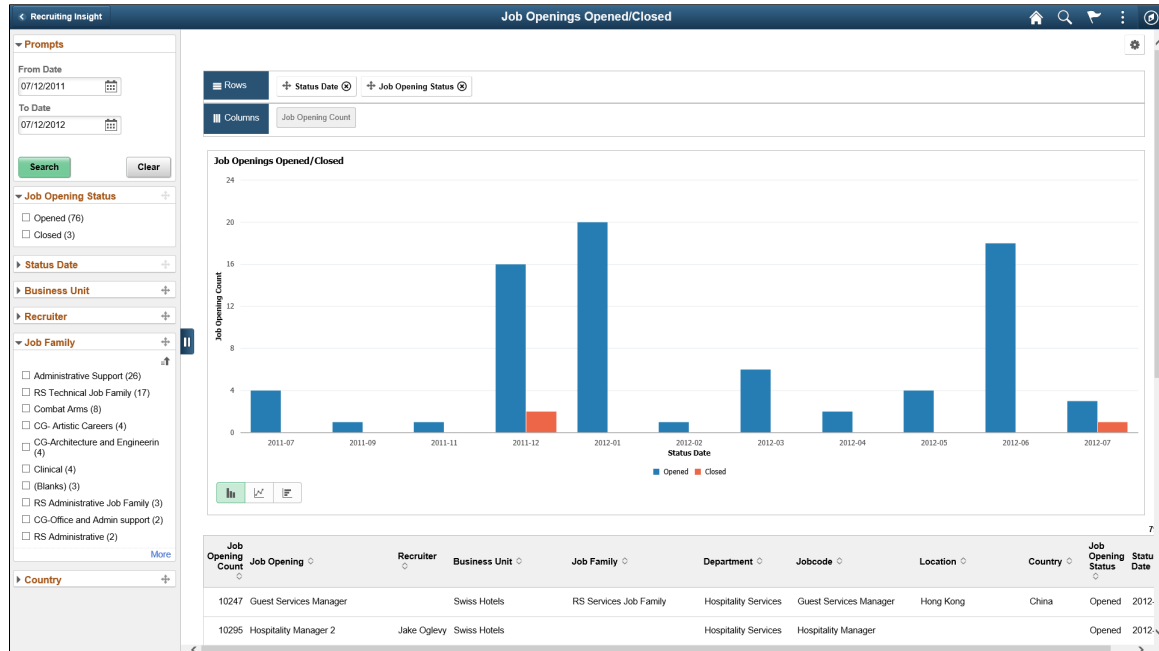

The Job Opened/Closed pivot grid displays monthly job opening data. By default, the data appears as a bar chart. For each month, one bar represents the number of job openings that were opened, and a second bar represent the number of job openings that were filled.

The opening date for a job opening is considered to be the earliest posting date or, if there are no postings defined, the actual job opening date. The closing date is the date that the job opening status changed to *Filled/Closed*.

The chart represents data for job openings to which the user has security access.

## Applicant Diversity Tile

Use the Applicant Diversity tile (cref for the tile is HC\_HRS\_PG\_DIV\_OV\_FL) to view diversity data by applicant.

Navigation:

Click the Recruiting Insight tile on Fluid Recruiting Homepage. The Applicant Diversity tile is on the Recruiting Insight dashboard.

This example illustrates the Applicant Diversity tile.

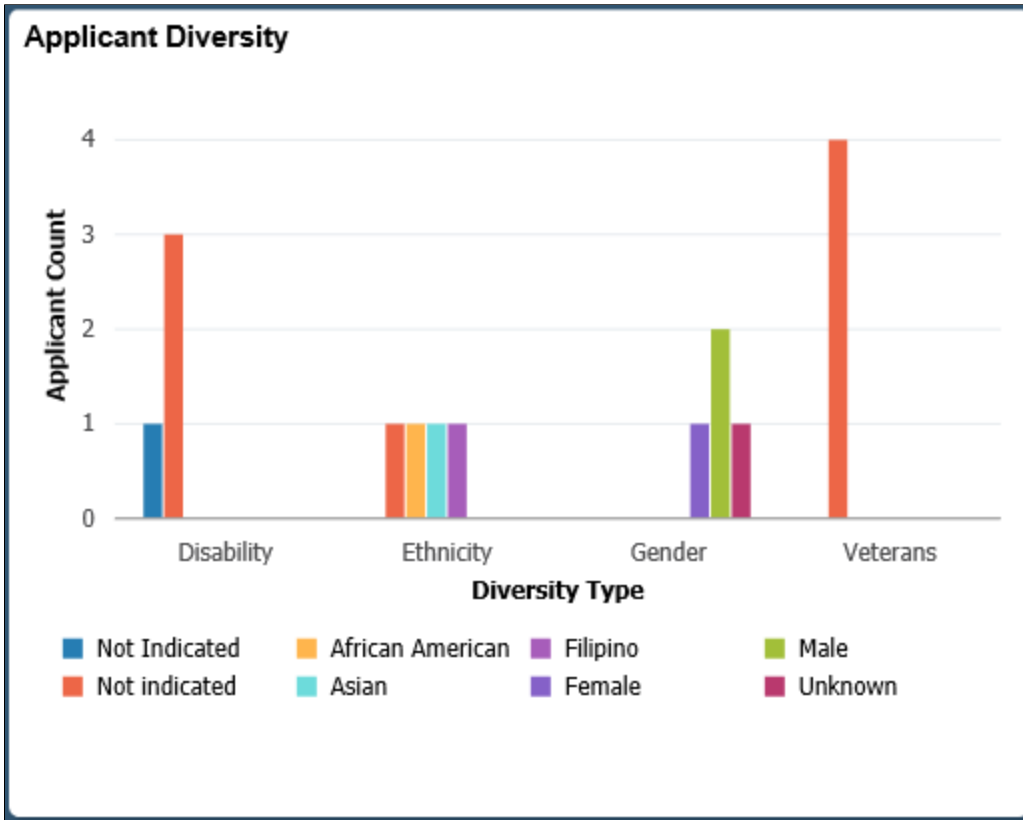

Click anywhere on the tile to access the Applicant Diversity pivot grid.

### Applicant Diversity Pivot Grid

Use the Applicant Diversity Pivot grid to view diversity data by application.

Navigation:

Click the Applicant Diversity tile on the Recruiting Insight dashboard.

This example illustrates the Applicant Diversity Pivot grid.

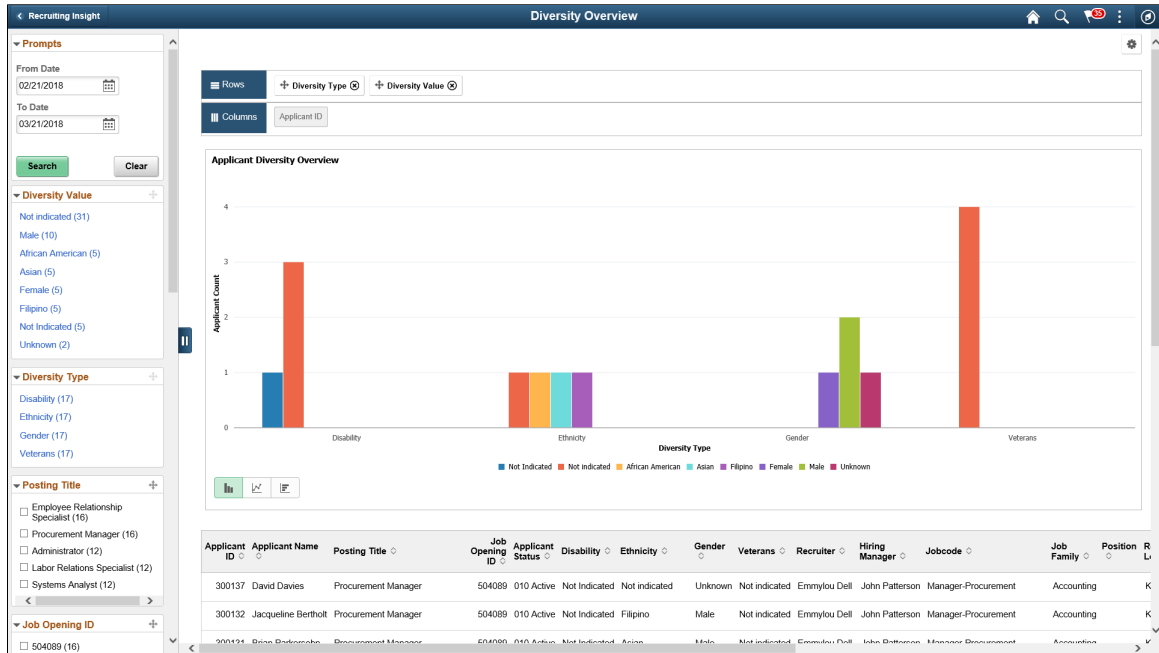

## Applications Diversity Tile

Use the Applications Diversity tile (cref for the tile is HC\_HRS\_PG\_DA\_APPLN\_FL) to view diversity data by application.

Navigation:

Click the Recruiting Insight tile on Fluid Recruiting Homepage. The Applications Diversity tile is on the Recruiting Insight dashboard.

This example illustrates the Applications Diversity tile.

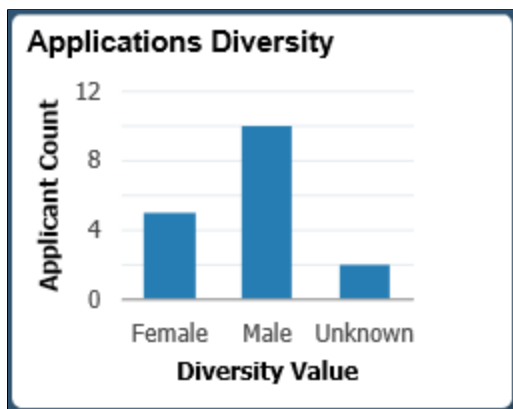

Click anywhere on the tile to access the Applications Diversity pivot grid.

## Applications Diversity Pivot Grid

Use the Applications Diversity pivot grid to view diversity data by application.

## Navigation:

Click the Applications Diversity tile on the Recruiting Insight dashboard.

This example illustrates the fields and controls on the Applications Diversity pivot grid.

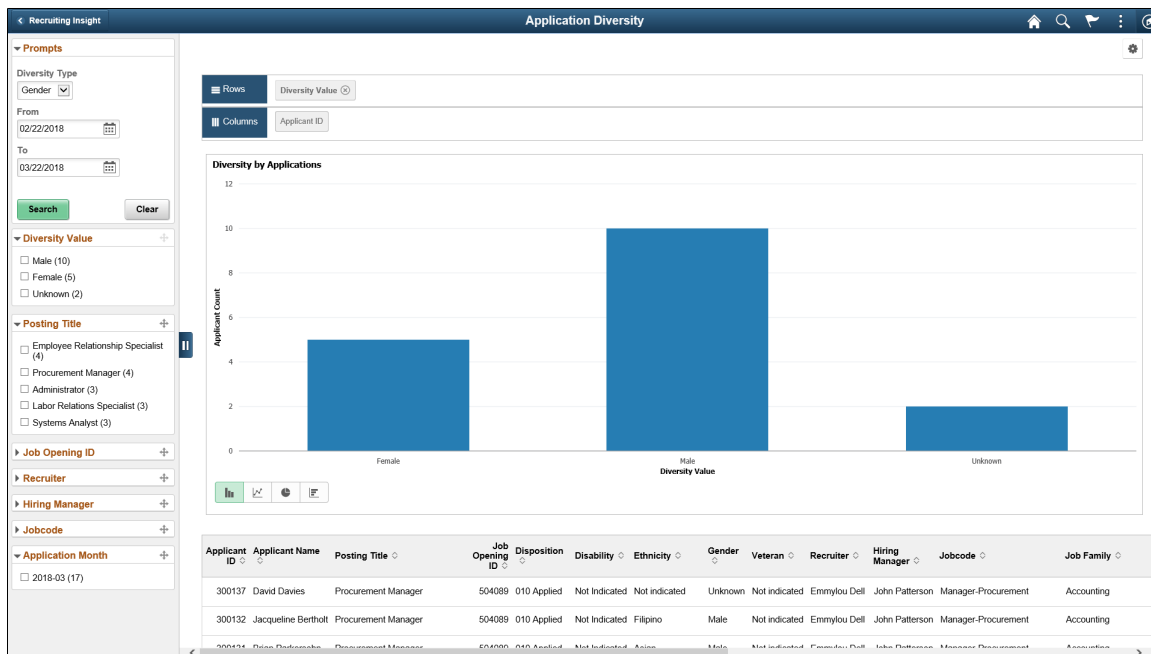

## Viewing Recruiting Insights

Recruiters and recruiting managers can use the Recruiting Insights dashboards to view and analyze the job openings and job applications. Based on the user privileges and criteria, the recruiting administrators can gain insights into the recruiter data.

The Recruiting Insights dashboards are built on the PeopleSoft Insights platform, which relies on an underlying analytics engine and search engine. Recruiting data that is visible on the dashboard comes from the recruiting search indexes.

These videos provide an overview of the PeopleSoft Insights feature:

Video: [Insights with PeopleSoft](#)

Video: [PeopleSoft HCM Insights](#)

Video: [Image Highlights, PeopleSoft HCM Update Image 34: HCM Insights](#)

This topic provides an overview of how to set up the Insights Dashboard for Recruiting analytics and discusses the PeopleSoft Insights Dashboards for Recruiting.

For more information on Insights dashboards, see PeopleTools Search Technology, “Monitoring PeopleSoft Search Framework and OpenSearch” and “Working with Insights Dashboards for PeopleSoft Application Data” documentation.



## Understanding PeopleSoft Insights

PeopleSoft Insights is an analytical engine that provides visual reports (visualizations) in the form of charts, tables, graphs and so on. The visualizations are based on queries that retrieve data from the PeopleSoft Search Framework.

For information on Insights dashboards, see:

- “Understanding PeopleSoft Insights” (Application Fundamentals)
- *PeopleTools Search Technology*: “Monitoring PeopleSoft Search Framework and OpenSearch” and “Working with Insights Dashboards for PeopleSoft Application Data” documentation

## Pages Used to View Recruiting Insights

<b>Page Name</b>	<b>Definition Name</b>	<b>Usage</b>
<a href="#">Recruiting Insight Tile</a>	HC_HRS_MY_ANALYTICS_FL_LINK (this is the cref for the tile)	Access the Recruiting Insights home page for recruiting analytics.
<a href="#">Recruiting Insight Home Page</a>	HC_HRS_MY_ANALYTICS_FL_LINK	Access the collection of recruiting insights tiles.
<a href="#">Application Details Tile</a>	HC_HRS_APPLICATION_DBRD_FL (cref for the tile)	Access the Application Details Insights dashboard.
<a href="#">Application Details Insights Dashboard</a>	HC_HRS_APPLICATION_DBRD_FL	Review Insights visualizations related to the job applications based on your row level security.
<a href="#">Recruiter Pipeline Tile</a>	HC_HRS_RECRUITER_DBRD_FL (cref for the tile)	Access the Recruiter Pipeline dashboard.
<a href="#">Recruiter Pipeline Dashboard</a>	HC_HRS_RECRUITER_DBRD_FL	Review Insights visualizations related to the job openings based on your row level security.
<a href="#">Recruitment Admin Dashboard Tile</a>	HC_HRS_RECRUITMENT_ADM_DBRD_FL (cref for the tile)	Access the Recruitment Admin dashboard.
<a href="#">Recruitment Admin Dashboard</a>	HC_HRS_RECRUITMENT_ADM_DBRD_FL	Review Insights visualizations related to the recruiter data based on your row level security.

## Understanding How to Set Up the Insights Dashboard for Recruiting Analytics

Before users can access the recruiting insights dashboards, the following steps should be performed:

## 1. Deploy and run the below search indexes.

(PeopleTools &gt; Search Framework &gt; Administration &gt; Deploy Search Objects)

- HC\_HRS\_APP\_INDEX
- HC\_HRS\_JOB\_OPENING
- HC\_HRS\_RCMNT\_ALL
- HC\_HRS\_RECRUITER\_RCMNT\_ALL

## 2. Deploy the below dashboards:

- Application Details Insights
- Application Details
- Recruitment Admin Tile Dashboard
- Recruitment Admin Dashboard
- Recruiter Pipeline
- Recruiter Pipeline Tile Dashboard
- Application - External vs Internal

(PeopleTools &gt; Search Framework &gt; Administration &gt; Deploy Insights Dashboards)

## 3. Assign the following user roles to users to access and view the recruiting dashboards:

<b>Dashboard</b>	<b>Roles</b>
Application Details Insights	Recruiter Fluid Recruiter Manager Fluid Recruitment Admin Fluid
Recruiter Pipeline	Recruiter Fluid Recruiter Manager Fluid Recruitment Admin Fluid
Recruitment Admin	Recruitment Admin Fluid

For more information about the Deploy Insights Dashboards page, see *PeopleTools Search Technology: “Working with Insights Dashboards for PeopleSoft Application Data”*, Managing a Delivered Dashboard.

The field **From Application Date** in Build Search Index Settings page is used to configure defaults for Recruitment Indexes used in Recruiter and Recruiter Admin Dashboards.

For example, if you select the value **Last 6 months**, all applications updated in last six months are indexed.

Selecting **ALL** for **From Application Date** will index all applications. However, selecting this option may cause performance issues in the Recruitment Indexes. It is recommended not to use **ALL** for **From Application Date** if the volume of total applications is high (more than a million). But, if total number of applications in customer environment is less then **ALL** option can be used.

By default, this field is set as **Last 6 months**.

### Related Links

“Understanding Real Time Indexing in HCM” (Application Fundamentals)

## Recruiting Insight Tile

Use the Recruiting Insight tile to access the [Recruiting Insight Home Page](#).

Navigation

The Recruiting Insight tile is available in the Fluid Recruiting home page.

This example illustrates the fields and controls on the Recruiting Insight tile.

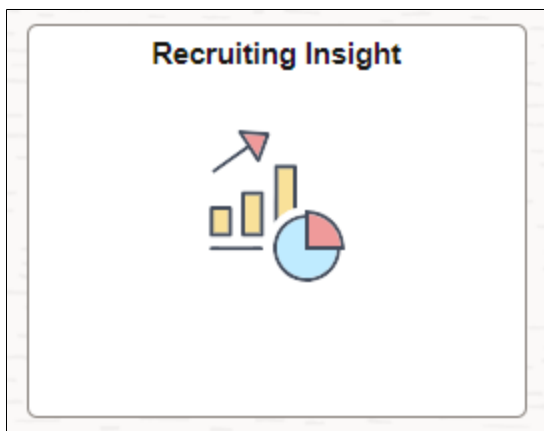

## Recruiting Insight Home Page

Use the Recruiting Insight Home page (HC\_HRS\_MY\_ANALYTICS\_FL\_LINK) to access the Recruiting Insights Dashboards.

Navigation

**Recruiting > Recruiting Insight**

This example illustrates the fields and controls on the Recruiting Insight home page.

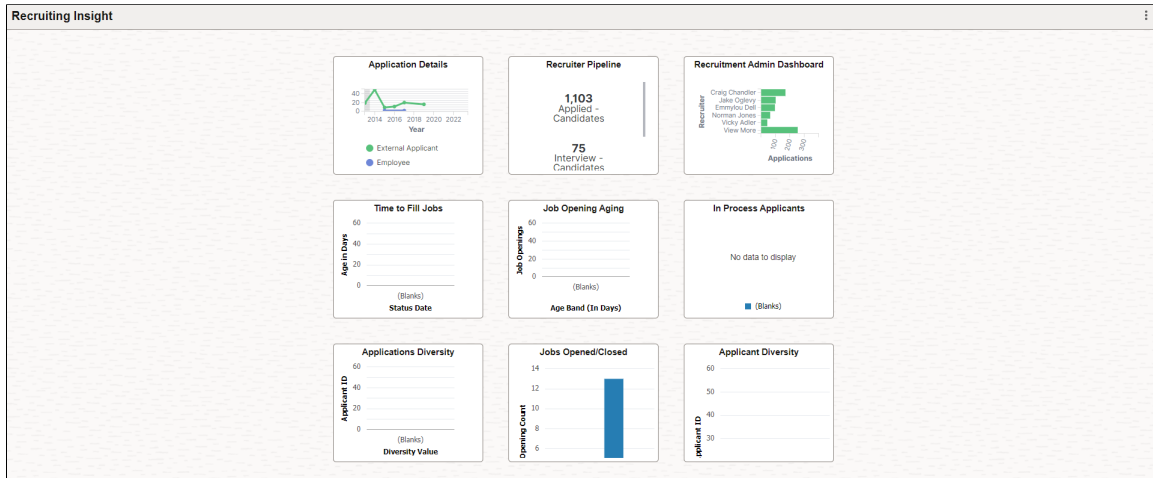

The Recruiting Insight Home Page delivers the following insights tiles through which you can access the Insights Dashboards:

- Application Details tile
- Recruiter Pipeline tile
- Recruitment Admin Dashboard tile

These tiles are also available in the Fluid Recruiting home page.

## Application Details Tile

Use the Application Details tile to access the Insights visualizations related to job applications based on your row level security.

Navigation

**Recruiting > Recruiting Insight > Application Details**

This example illustrates the fields and controls on the Application Details tile.



Select the Application Details tile to access the [Application Details Insights Dashboard](#).

## Application Details Insights Dashboard

Use the Application Details Insights dashboard (HC\_HRS\_APPLICATION\_DBRD\_FL) to review the Insights visualizations related to job applications based on your row level security.

Select the [Application Details Tile](#).

This example illustrates the Application Details Insights dashboard.

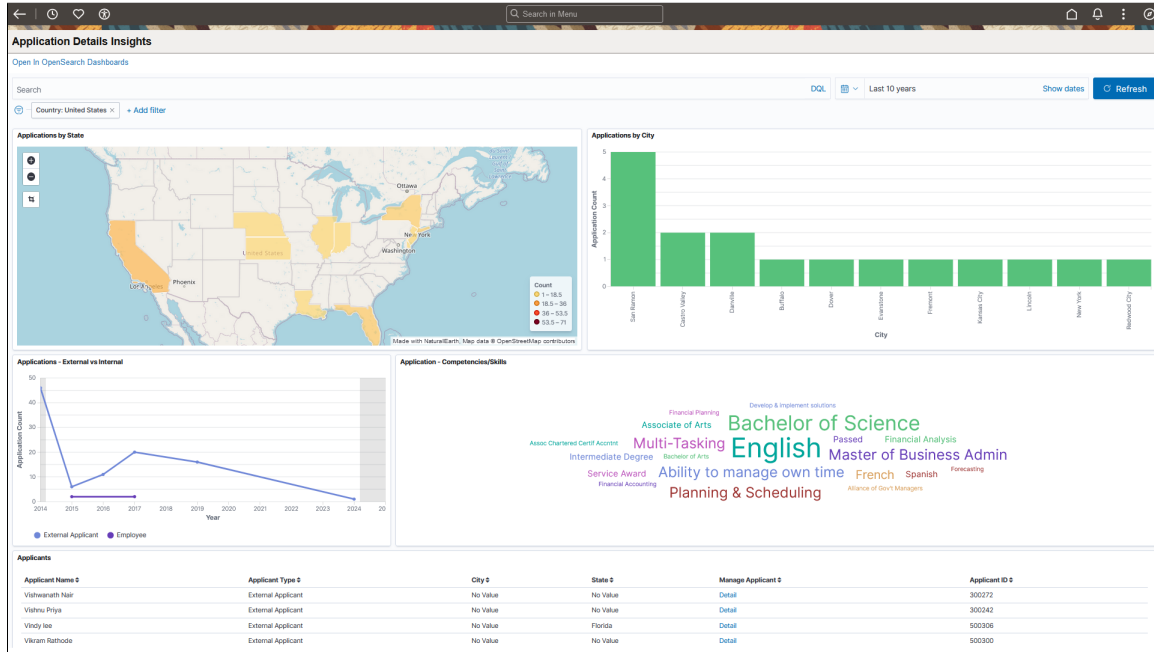

**Warning!** PeopleSoft Insights dashboards may not render properly if you access them using unsupported platforms.

The Application Details Insights dashboard provides you with different visualizations to analyze the job applications data. When you select filters or chart items, Insights dynamically updates all visualizations using the sources from the index.

Each visualization enables you to inspect the chart, table or map to view the details of that visualization. Pause over a visualization to have the have additional page elements appear, view numbers, or click items to add filters to your visualizations.

For more information on working with PeopleSoft Insights and filters, see *PeopleTools: Search Technology*, “Working with Insights Dashboards for PeopleSoft Application Data” documentation.

### Delivered Application Details Insights Visualizations

The Application Details Insights dashboard provides this collection of visualizations:

<b>Visualization</b>	<b>Description</b>
<b>Applications by State</b>	<p>The Applications by State visualization shows the region map or the geographical distribution of applications on an interactive map. This shows the states where the applicants reside.</p> <p>You can use the Applications by State view to filter the data based on a state. For example if you click on California State, then the visualization in the other charts show the data only from applicants residing in California State.</p> <p>By default, the country filter is set to USA for Application by State visualization. To change the default view to a different country, the visualization needs to be modified and the corresponding filter needs to be added.</p>
<b>Applications by City</b>	<p>The Applications by City visualization shows a vertical bar graph of the number of applicants from each city.</p> <p>You can click on a city to filter the visualization for that city only. For example if we click on San Ramon, the rest of the charts show the data only from applications residing in San Ramon.</p>
<b>Applications – External vs Internal</b>	<p>The Applications – External vs internal line graph shows a trend comparison between the number of applications received from external candidates compared to internal candidates over a period of time.</p> <p>Click on either of the line to filter the applications based on external applications or Internal applications. For example, if we click on the External graph, then the rest of the visualizations show the corresponding visualization of only external applicants</p>
<b>Application – Competencies/Skills</b>	<p>The Application – Competencies/Skills shows an interactive tag cloud visualization of the competencies and skills mentioned by the applicants. This tag cloud helps users to understand the more common or frequently mentioned competencies and skills across applications.</p> <p>Click on a word in the tag cloud visualization to filter only those applications that has a mention of that competency or skill. The other visualizations automatically show details of applications that contain the filtered competency or skill. For example, if you click on <i>English</i>, the visualization shows details of applicants that have this skill mentioned in their application.</p>

<b>Visualization</b>	<b>Description</b>
<b>Applicants</b>	<p>The Applicants section lists out all the applicants and their details in tabular form. You can find the detail of a particular applicant under the manage Applicant column.</p> <p>Click the Detail link against an Applicant in the Manage applicant column to open the Applicant details in the Manage Applicant page.</p>

## Recruiter Pipeline Tile

Use the Recruiter Pipeline tile to access the Insights visualizations related to job openings based on your row level security.

Navigation

**Recruiting > Recruiting Insight > Recruiter Pipeline**

This example illustrates the fields and controls on the Recruiter Pipeline tile.

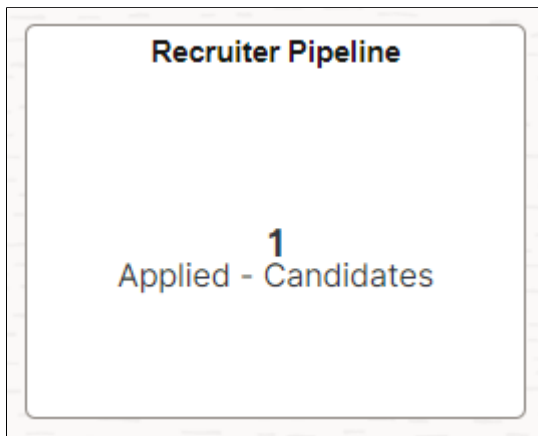

Select the Recruiter Pipeline tile to access the [Recruiter Pipeline Dashboard](#).

## Recruiter Pipeline Dashboard

Use the Recruiter Pipeline Dashboard (HC\_HRS\_RECRUITER\_DBRD\_FL) to access the insights visualizations related to job openings based on the logged in recruiter.

Select the [Recruiter Pipeline Tile](#).

This example illustrates the Recruiter Pipeline Dashboard.

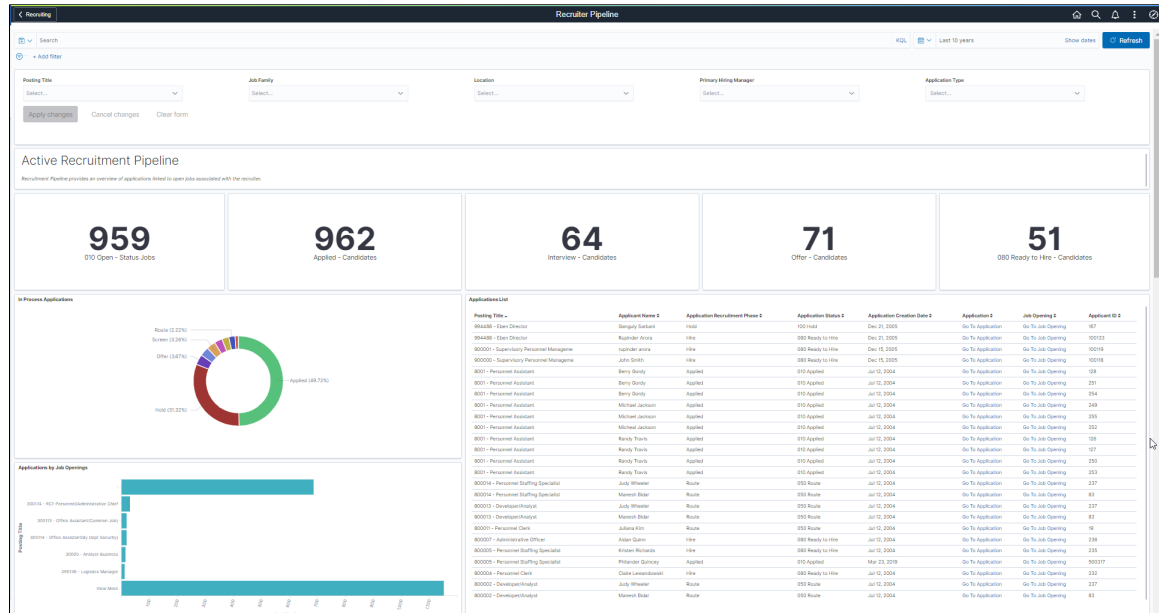

You can filter the visualizations based on **Posting Title**, **Job Family**, **Location**, **Primary Hiring Manager**, and **Application Type**. Visualizations on Dashboard react to the changes made in these filters. For more information, see PeopleTools Search Technology, “*Working with Insights Dashboards for PeopleSoft Application Data*”.

## Active Recruitment Pipeline

This group of visualizations helps the Recruiter to view and manage their open backlog. These visualizations are independent of the selected date range.

It includes:

- Metrics Visualizations
- In Process Applications Visualization
- Applications by Job Openings Visualization
- Applications List

**Note:** The visualizations grouped under Active Recruitment Pipeline are not dependent on the selected date range. This allows all jobs that are open to be available for review.

## Metrics Visualizations

Metric visualization displays the count of:

- Open Jobs: Count of open jobs (posted as well as non-posted) associated with the Recruiter.
- Applied Jobs: Count of applicants in the applied phase associated with the Recruiter.
- Interview: Count of applicants in the interview phase associated with the Recruiter.
- Offer: Count of applicants in the offer phase associated with the Recruiter.



- Ready to Hire: Count of applicants in the ready to hire status associated with the Recruiter.

By default, these metrics display both applications tied to a job opening and applied without a job. Use the **Application Type** filter to filter as needed.

Click on each metric value to add corresponding filters to the dashboard.

This example illustrates the Metric Visualizations.

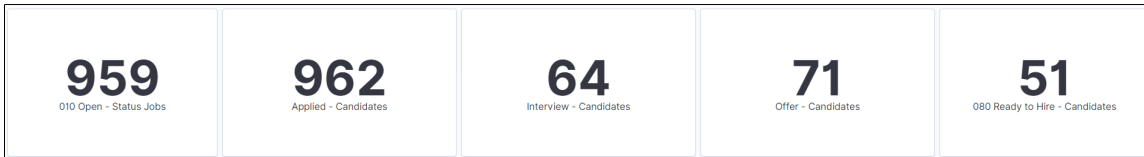

### In Process Applications Visualization

In Process Applications visualization shows the applications that are under processing based on all recruitment phases.

This example illustrates the In Process Applications Visualization.

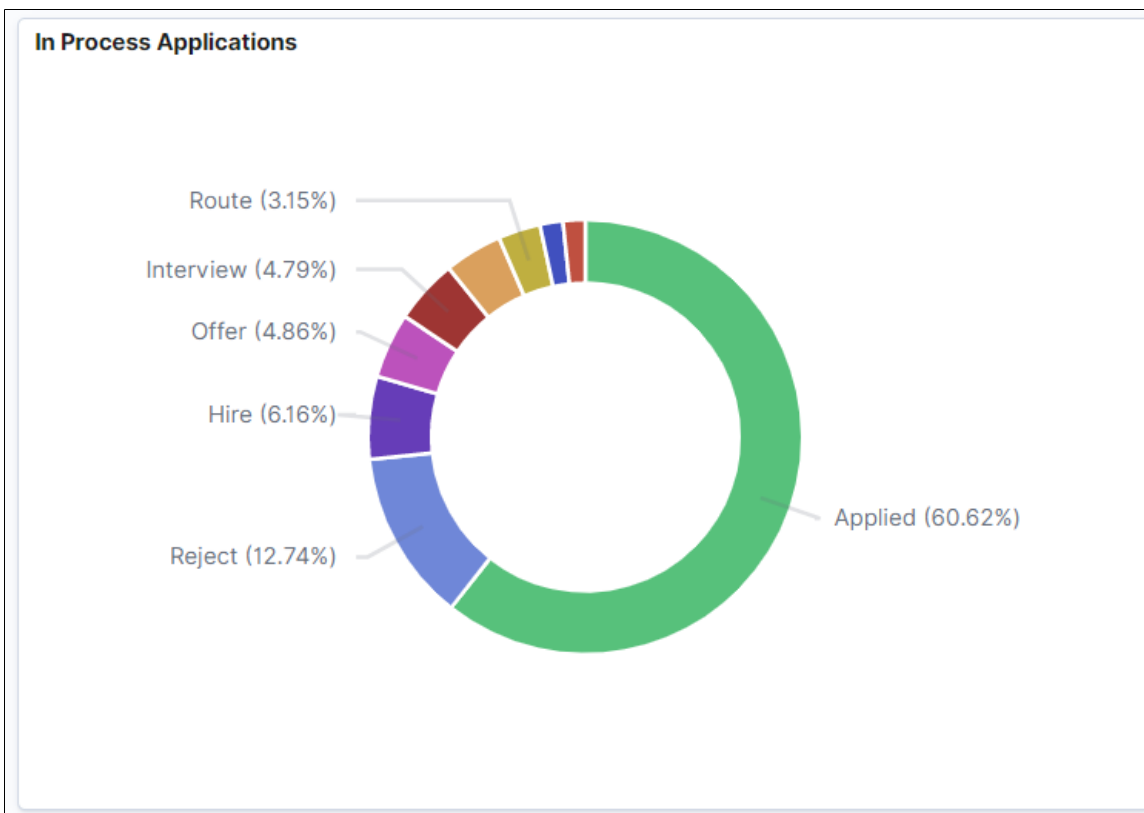

### Applications by Job Openings Visualization

Applications by Job Openings visualization shows the number of applications received for each job title/ job opening.

By default, six job openings with the greatest number of applications are displayed in the chart. You can view the rest of job openings by clicking *View More*.

This example illustrates the Applications by Job Openings Visualization.

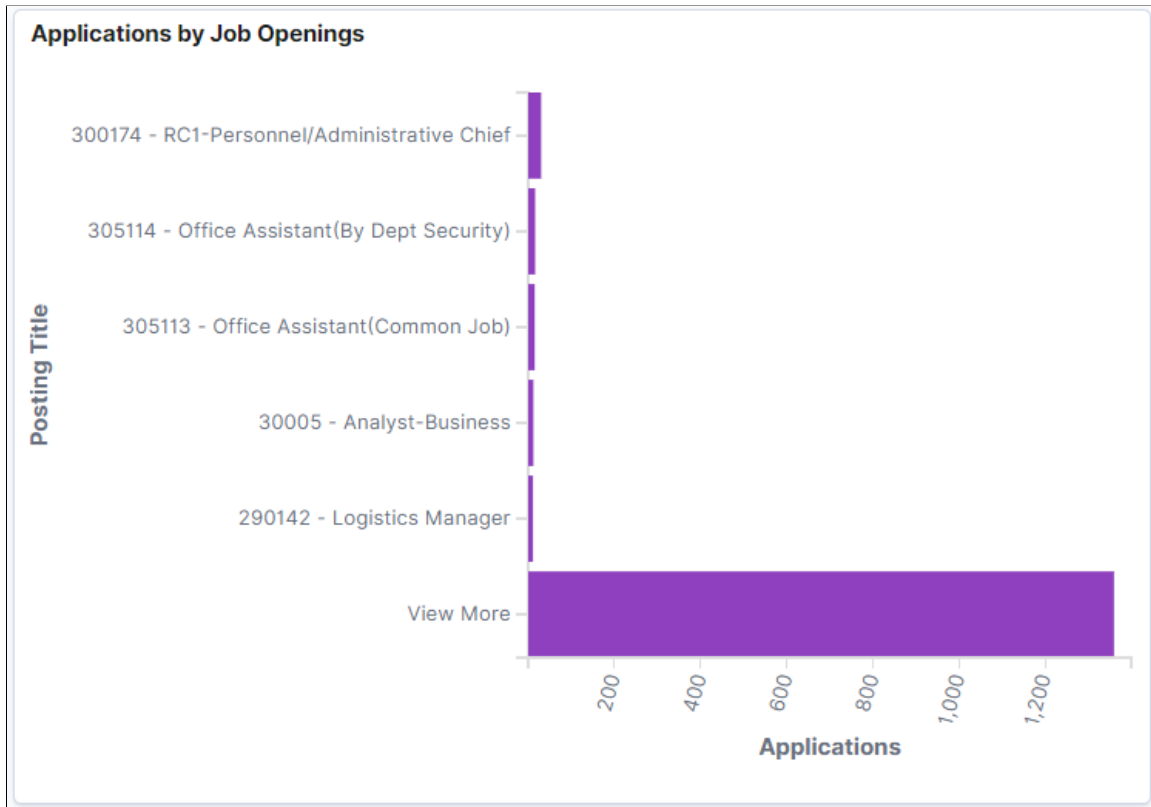

### Applications List Grid

Application List displays all the job openings, applications received, and their details in tabular form, based on the applied filter. The recruiter can transfer directly to the Application page or the Job Opening page.

This example illustrates the Applications List Visualization.

Posting Title	Applicant Name	Recruiting Phase/Disposition	Application Status	Application Creation Date	Application	Job Opening	Applicant ID
	Hanumanth Rao	Reject	110 Reject	Dec 11, 2011	<a href="#">Go To Application</a>	<a href="#">Go To Job Opening</a>	500198
994488 - Eben Director	Ganguly Sarbani	Hold	100 Hold	Dec 21, 2005	<a href="#">Go To Application</a>	<a href="#">Go To Job Opening</a>	167
994488 - Eben Director	Rupinder Arora	Hire	080 Ready to Hire	Dec 21, 2005	<a href="#">Go To Application</a>	<a href="#">Go To Job Opening</a>	100133
900001 - Supervisory Personnel Manageme	rupinder arora	Hire	080 Ready to Hire	Dec 15, 2005	<a href="#">Go To Application</a>	<a href="#">Go To Job Opening</a>	100119
900000 - Supervisory Personnel Manageme	John Smith	Hire	080 Ready to Hire	Dec 15, 2005	<a href="#">Go To Application</a>	<a href="#">Go To Job Opening</a>	100118
8001 - Personnel Assistant	Berry Gordy	Applied	010 Applied	Jul 12, 2004	<a href="#">Go To Application</a>	<a href="#">Go To Job Opening</a>	128
8001 - Personnel Assistant	Berry Gordy	Applied	010 Applied	Jul 12, 2004	<a href="#">Go To Application</a>	<a href="#">Go To Job Opening</a>	251
8001 - Personnel Assistant	Berry Gordy	Applied	010 Applied	Jul 12, 2004	<a href="#">Go To Application</a>	<a href="#">Go To Job Opening</a>	254
8001 - Personnel Assistant	Michael Jackson	Applied	010 Applied	Jul 12, 2004	<a href="#">Go To Application</a>	<a href="#">Go To Job Opening</a>	249
8001 - Personnel Assistant	Michael Jackson	Applied	010 Applied	Jul 12, 2004	<a href="#">Go To Application</a>	<a href="#">Go To Job Opening</a>	255
8001 - Personnel Assistant	Micheal Jackson	Applied	010 Applied	Jul 12, 2004	<a href="#">Go To Application</a>	<a href="#">Go To Job Opening</a>	252
8001 - Personnel Assistant	Randy Travis	Applied	010 Applied	Jul 12, 2004	<a href="#">Go To Application</a>	<a href="#">Go To Job Opening</a>	126
8001 - Personnel Assistant	Randy Travis	Applied	010 Applied	Jul 12, 2004	<a href="#">Go To Application</a>	<a href="#">Go To Job Opening</a>	127
8001 - Personnel Assistant	Randy Travis	Applied	010 Applied	Jul 12, 2004	<a href="#">Go To Application</a>	<a href="#">Go To Job Opening</a>	250
8001 - Personnel Assistant	Randy Travis	Applied	010 Applied	Jul 12, 2004	<a href="#">Go To Application</a>	<a href="#">Go To Job Opening</a>	253
800014 - Personnel Staffing Specialist	Judy Wheeler	Route	050 Route	Jul 12, 2004	<a href="#">Go To Application</a>	<a href="#">Go To Job Opening</a>	237
800014 - Personnel Staffing Specialist	Manesh Bidar	Route	050 Route	Jul 12, 2004	<a href="#">Go To Application</a>	<a href="#">Go To Job Opening</a>	83

### Total Applications by Job Postings Visualization

This visualization helps the recruiter to view and analyze the applications based on total applications and days since the job was first posted. This is helpful in reviewing jobs that do not have any applications.

This example illustrates the Total Applications by Job Postings Visualization.

**Total Applications by Job Postings**

Use the slider to select the range of applications associated with job openings

**Total Applications**

0 ————— 16

**Days Since Job Posted**

1 ————— 244

[Apply changes](#) [Cancel changes](#)

**Posted Jobs List**

Posting Date	Posting Title	Primary Recruiting Location	Days Since Job Posted	Total Applications	Days Left to Close	Job Opening	Job Opening ID
Jan 1, 2021	AUS Salary Packaging Ssr Mgr Human Resources	Sydney	244	1	60	<a href="#">Go to Job Opening</a>	10144
Jan 1, 2021	Accountant	Delaware Operations	244	3	60	<a href="#">Go to Job Opening</a>	290104
Jan 1, 2021	Accountant (ERP)	Aspen	244	3	60	<a href="#">Go to Job Opening</a>	10228
Jan 1, 2021	Accounts Director		244	5	60	<a href="#">Go to Job Opening</a>	100049
Jan 1, 2021	Accounts Executive I	New York	244	6	60	<a href="#">Go to Job Opening</a>	10202
Jan 1, 2021	Accounts Executive II	New York	244	0	60	<a href="#">Go to Job Opening</a>	10206

You can use the slider to filter the data based on the number of **Total Applications** received and **Days Since Job Posted**. The range of the slider is set according to minimum and maximum applications associated with job postings. The extreme values in the sliders for **Total Applications** and **Days Since Job Posted** are determined by the data present in applications. For example, if minimum value for Total Applications associated with a job is 0 and maximum value is 16 then 0 and 16 will be set as the extreme values for slider.

Once applied, the Posted Jobs List grid displays the associated job openings, and other details, based on the selected range of job applications. If the job opening has a close date, the grid will show the number of days left until it is closed.

## Recruitment Metrics

This group of visualizations helps the Recruiter visualize historical data based on the selected date range for both open and closed jobs to understand recruitment trends.

**Note:** Please review your organization’s policy on Recruiters having access to Veteran Data. Each organization may be different.

### Veteran Applications Visualizations

Veteran’s data on the Recruiter Pipeline is represented by three visualizations:

- **Veteran Applications Metrics:** Displays the count of veteran applications received for job openings associated with the Recruiter.
- **Veteran Application Phases:** Displays how all veteran applications received for job openings associated with the Recruiter have progressed through various Recruiting Phases.
- **Veteran Applications List:** Displays all the veteran applications received for the job openings associated with the Recruiter in a tabular form.

**Note:** Please review your organization’s policy on Recruiters having access to Veteran Data. Each organization may be different.

This example illustrates the Veteran Applications Visualization.

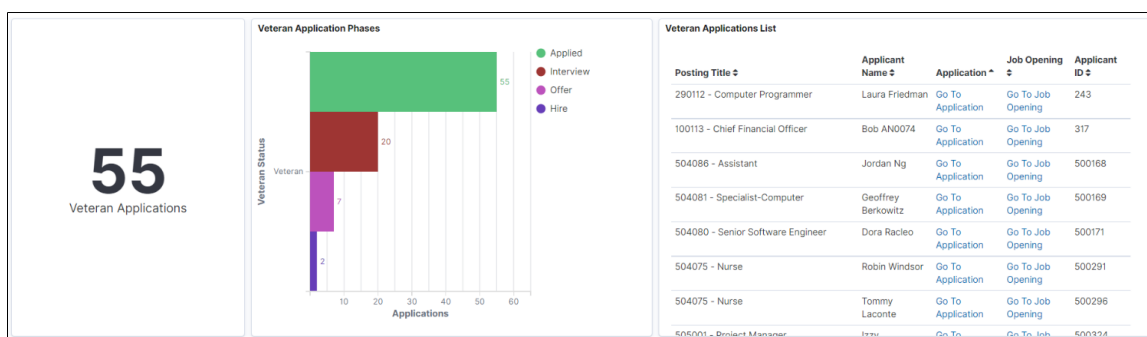

### Offer Declined Reasons Visualizations

Offers Declined data on Recruiter Pipeline is represented by three visualizations.

- **Offers Declined Metrics:** Displays the count of job offers declined for the applications on job openings associated with Recruiter.

- Offers Declined Reasons: Displays the reasons given by the applicants for declining the offers.
- Offers Declined List: Displays the offers declined in a tabular form.

This example illustrates the Offer Declined Reasons Visualization.

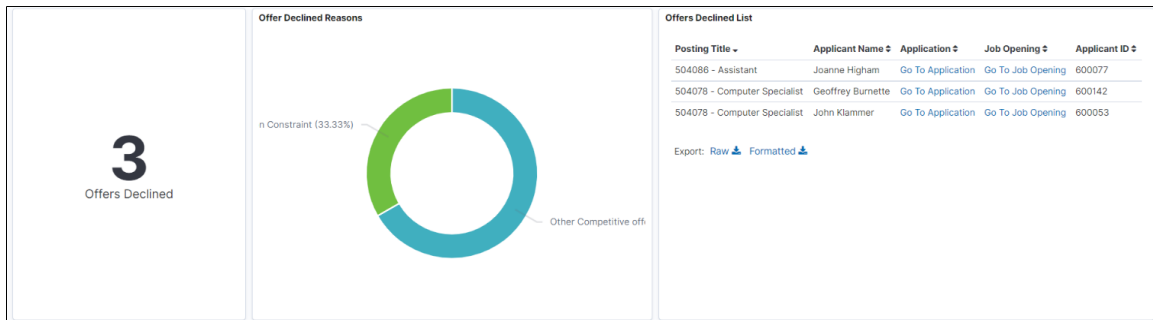

### Days to Hire by Postings Visualization

Days to Hire by Postings visualization shows the average number of days to move a job application from the Applied to the Hire phase. Also, a bar chart visualizes the same data based on individual job openings associated with the recruiter.

Days to Hire by Postings may not show all Closed Jobs but instead shows a subset of closed jobs. Yet the red line is based across all closed Jobs to provide an accurate average.

This example illustrates the Days to Hire by Postings Visualization.



### Applications by Sources Visualization

Application Sources visualization shows the Recruitment sources from which the recruiters receive the job applications (distributed across Applied, Interview, and Hire Recruitment Phases of Application).

This example illustrates the Applications by Source Visualization.

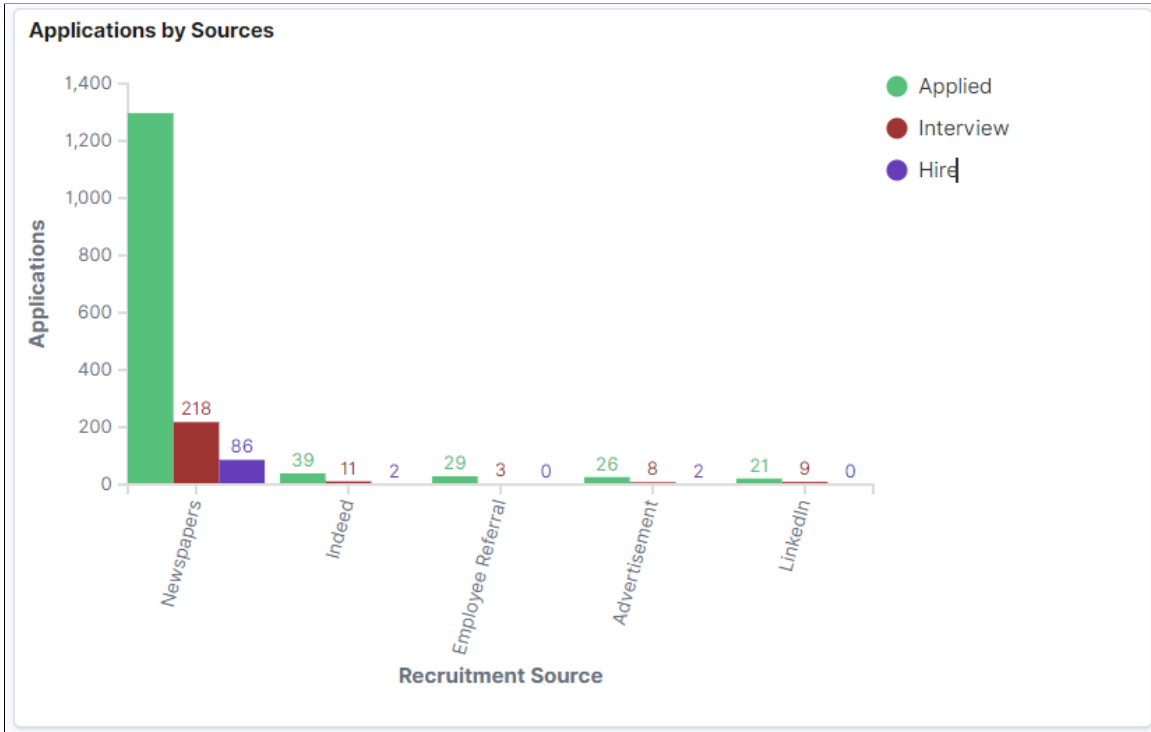

### Applications by Region (Postal Codes) Visualization

Applications by Region visualization shows the job applications based on the regions (postal codes). The system uses the postal codes associated with the applicant's address to map the region. This visualization can also be created using Country, State, or County.

**Note:** This visualization is currently not available with the OpenSearch implementation.

This example illustrates the Applications by Region (Postal Codes) Visualization.

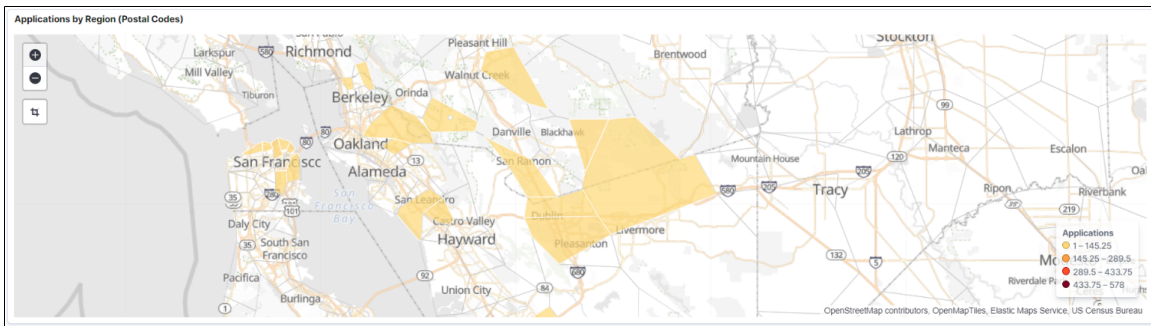

## Recruitment Admin Dashboard Tile

Use the Recruitment Admin Dashboard Tile to the Insights visualizations related to recruiter data based on your row level security.

Navigation

**Recruiting > Recruiting Insight > Recruitment Admin Dashboard**

This example illustrates the fields and controls on the Recruitment Admin Dashboard tile.

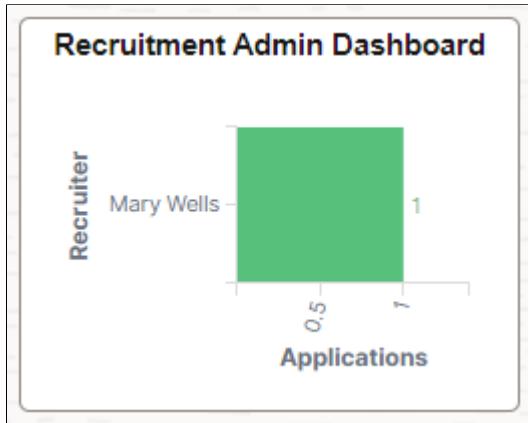

Select the Recruitment Admin Dashboard tile to access the [Recruitment Admin Dashboard](#).

## Recruitment Admin Dashboard

Use the Recruiter Admin Dashboard (HC\_HRS\_RECRUITMENT\_ADM\_DBRD\_FL) to access the insights visualizations related to the recruiter data based on your row level security.

Navigation

Select the [Recruitment Admin Dashboard Tile](#).

This example illustrates the Recruitment Admin Dashboard.

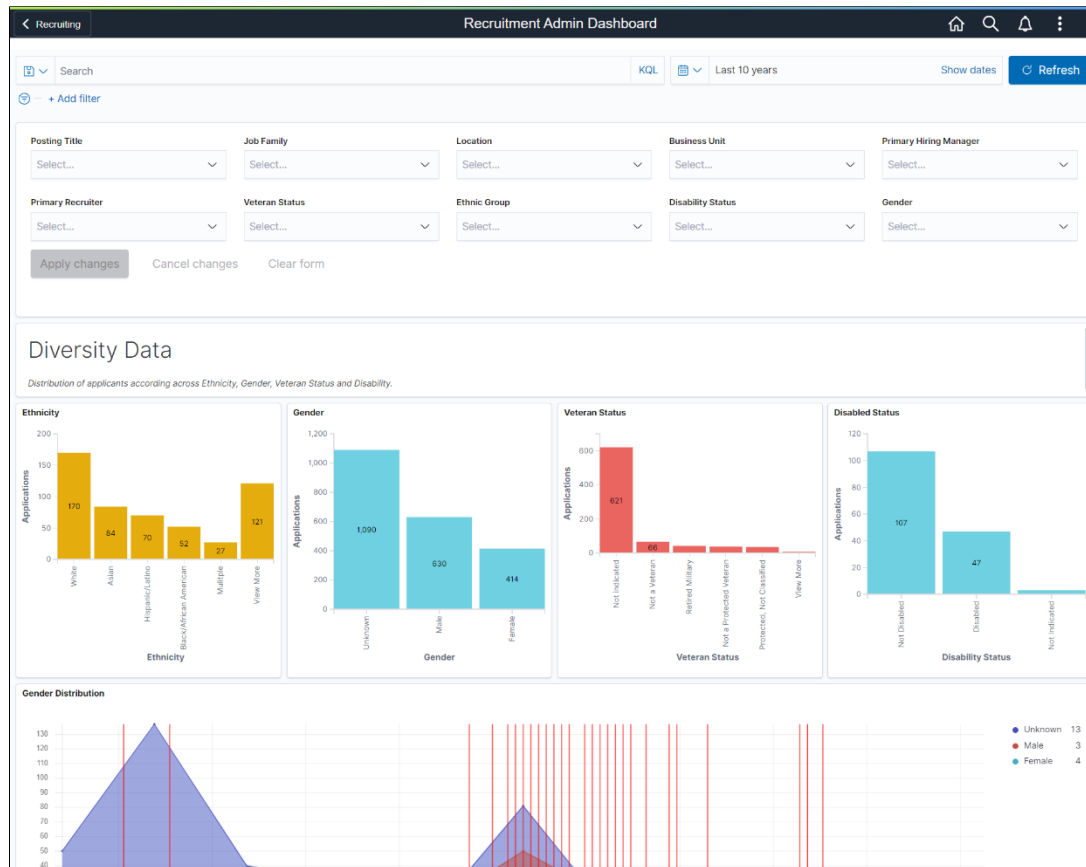

As a Recruitment Administrator, you can filter the data based on **Posting Title**, **Job Family**, **Location**, **Business Unit**, **Primary Hiring Manager**, **Primary Recruiter**, **Veteran Status**, **Ethnic Group**, **Disability Status**, and **Gender**. Visualizations can change based on the applied filter.

The visualizations on this Dashboard are grouped as:

- **Diversity Data Visualizations:** This group of visualizations helps to analyze the job applications based on diversity data.
- **Recruiter Workload Visualizations:** This group of visualizations helps to analyze the workload of each Recruiter.
- **Recruiter Data Visualizations:** This group of visualizations helps to visualize the Applications progression and days to hire associated with each Recruiter.

## Diversity Data Visualizations

This group of visualization helps the administrator to understand the diversity of the people who applied for each job postings. It includes:

- **Ethnicity:** The Ethnicity visualization shows a vertical bar graph of the number of applicants from each ethnic group.
- **Gender:** The Gender visualization shows a vertical bar graph of the number of applicants from each gender.



- **Veteran Status:** The Veteran Status visualization shows a vertical bar graph of the number of applicants for each veteran status.
- **Disabled Status:** The Disabled visualization shows a vertical bar graph of the number of applicants for each disabled status.
- **Gender Distribution:** The Gender Distribution visualization is a time series representation of applications by gender. This visualization also annotates the Veteran applications.

**Note:** Veteran Applications which are received on the same day or closer in time (within few days) are displayed in a single annotation. You can modify the annotation to display a rare event based on requirements. This can be done by editing the visualization and changing the **Annotation** tab.

This example illustrates the Diversity Data Visualizations.



## Recruiter Workload Visualizations

The Recruiter Workload visualizations help the administrator to understand the workload of each recruiter. It includes:

- **Days Since Job Posted:** Use the slider to select the days (days since the job is posted). The other two visualizations are displayed based on this selection. The range of slider is set according to minimum and maximum applications associated with job postings. The extreme values in the sliders are determined by the data present in applications. For example, if minimum value for **Total Applications** associated with a job is 0 and the maximum value is 16 then 0 and 16 will be set as the extreme values for slider.
- **Open Jobs by Recruiters:** Open Jobs by Recruiter shows the distribution of open job openings across Recruiters.

- **Recruiter Backlog (Applications in Applied Status):** The Recruiter Backlog shows the distribution of applied applications across Recruiters. The visualizations displayed are independent of the time filter to show all open jobs.

This example illustrates the Recruiter Workload Visualizations.

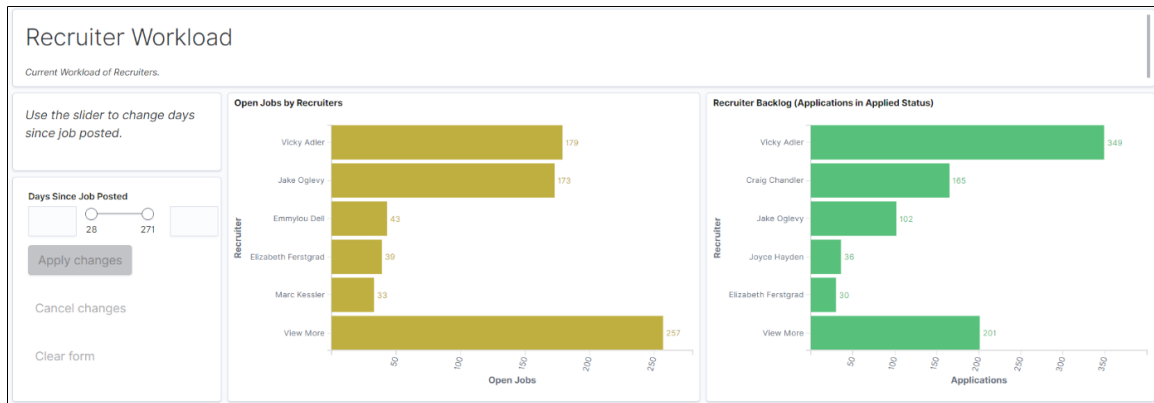

## Recruiter Data Visualizations

Recruiter Data Visualizations help the administrator to analyze applications progression and days to hire for each recruiter. It includes:

- **Recruitment Funnel:** Recruitment Funnel visualization shows the progress of applications across various recruitment phases.
- **Recruitment Funnel by Recruiters:** Recruitment Funnel by Recruiter visualization shows the progress of job applications across various recruitment phases for each recruiter.
- **Average Days to Hire By Recruiters:** Average Days to Hire visualization shows the average days to move job applications from the applied to hire phase. The bar chart represents the same data by each recruiter.

This example illustrates the Recruiter Data Visualizations.

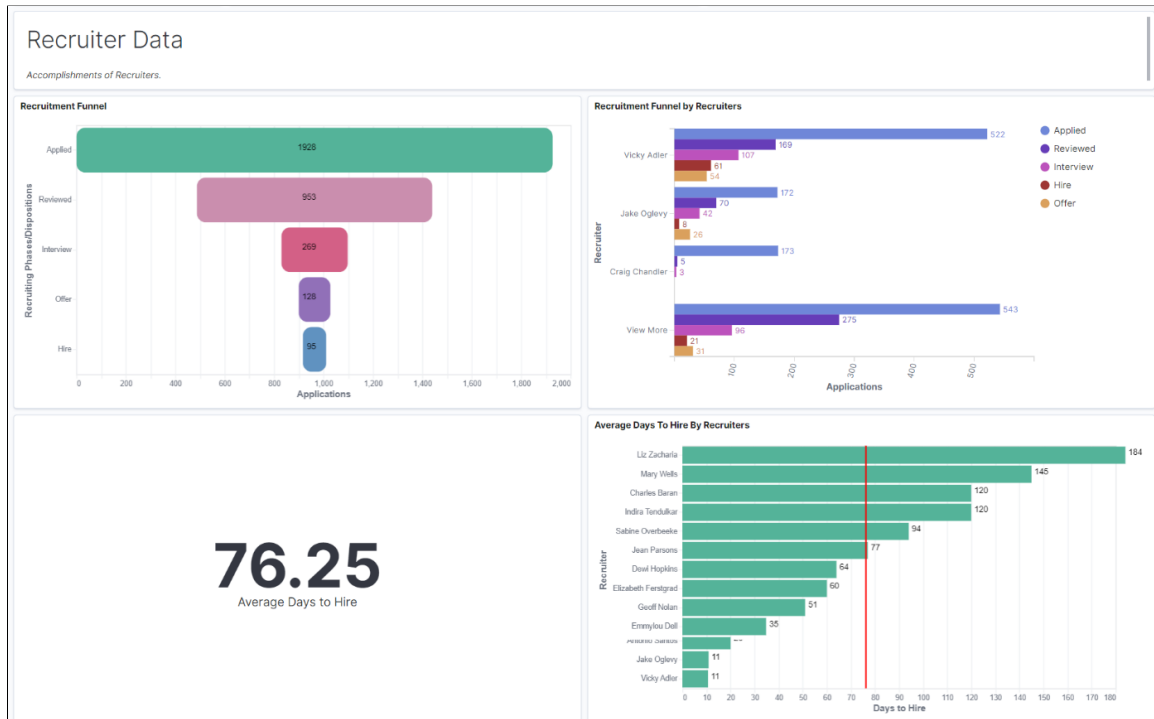

## Using the PeopleSoft Fluid User Interface to View Recruiting Manager Summary

This topic discusses how Recruiting Managers use the fluid Recruiting Manager Summary page to view summary information about the workload and effectiveness of recruiters who report to the current user. It also provides access to recruiting pivot grids that provide actionable operational analytics.

**Note:** Only users with the Recruiting Manager Fluid role can access this tile on the Fluid Recruiting Homepage.

For general information about fluid pages in PeopleSoft HCM, see “Understanding PeopleSoft Fluid User Interface Homepages” (Application Fundamentals).

## Pages Used to View Recruiting Manager Summary Using the PeopleSoft Fluid User Interface

Page Name	Definition Name	Usage
<a href="#">Recruiting Manager Summary Tile</a>	HC_HRS_MGR_SUMM_FLU_GBL (cref for the tile)	To access the Recruiting Manager Summary page.

<b>Page Name</b>	<b>Definition Name</b>	<b>Usage</b>
<u>Recruiting Manager Summary Page</u>	HRS_MGR_SUMM_FLU	View summary information about the workload and effectiveness of recruiters who report to you. This page shows information for direct reports only, not for the user's entire organization.

## Recruiting Manager Summary Tile

Recruiting Managers use the Recruiting Manager Summary tile (cref for the tile: HC\_HRS\_MGR\_SUMM\_FLU\_GBL) to access the Recruiting Manager Summary page.

Navigation:

The Recruiting Manager Summary tile is an optional tile on the delivered Fluid Recruiting Homepage.

This example illustrates the Recruiting Manager Summary tile.



## Recruiting Manager Summary Page

Recruiting Managers use the Recruiting Manager Summary page (HRS\_MGR\_SUMM\_FLU) to view summary information about the workload and effectiveness of recruiters who report to them. This page shows information for direct reports only, not for the user's entire organization.

---

**Note:** This page supports up to 300 direct reports. If a user with more than 300 direct reports attempts to use this page, the grid will stop after loading data for 300 direct reports, and the system will display a message to the user.

---

Navigation:

Click the Recruiting Manager Summary tile on the delivered Fluid Recruiting Homepage.

This example illustrates the fields and controls on the Recruiting Manager Summary page.

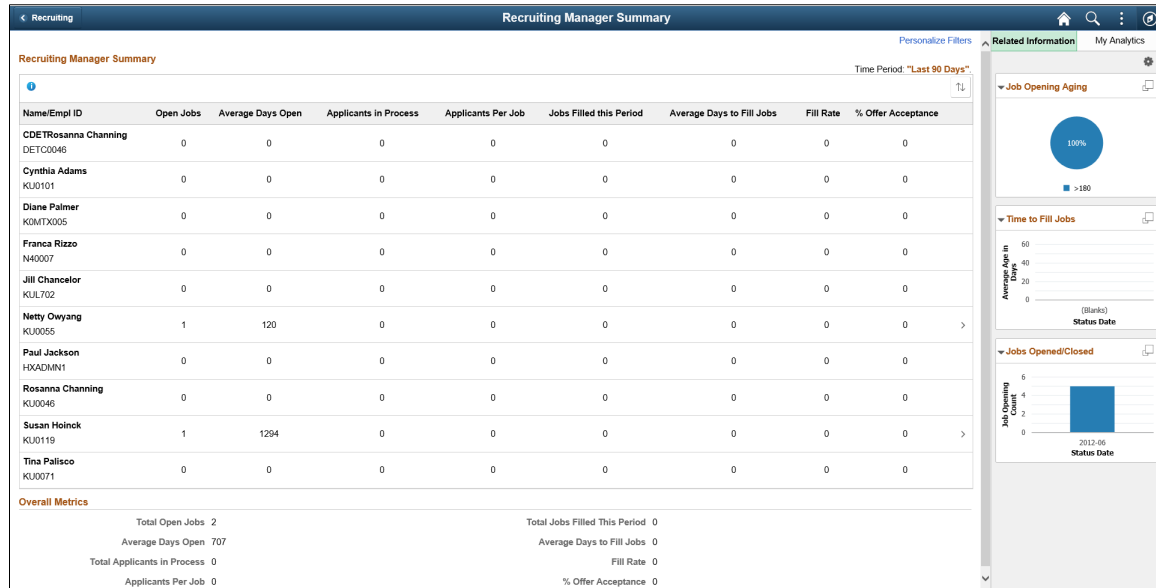

The Recruiting Manager Summary page shows a variety of metrics to gauge the workload and effectiveness of a recruiting manager's direct reports. All metrics are based on job openings where the direct report is the primary recruiter.

Click on any direct report's row to access the [Browse Job Openings Page](#) pre-filtered to show that direct report's open job openings.

## Personalizing Filters

Click the **Personalize Filters** link to choose the time period to include in the recruiting manager metrics and to set filter options to control which types of applicants and job openings are included.

This example illustrates the Personalize Filters modal window.

Cancel
Personalize Filters
Save

Specify the time period, types of applicants and whether to include hot jobs only for metric calculation and display.

**Time Period for Metrics**

Time Period (Last n Days)

**Filter Options**

Include External Applicants

Include Internal Applicants

Hot Jobs Only

## Time Period for Metrics

<i>Field or Control</i>	<i>Description</i>
<b>Time Period (Last n Days)</b>	Enter the number of days before today that the time period for recruiting manager metrics starts. The default value is 90.

## Filter Options

<i>Field or Control</i>	<i>Description</i>
<b>Include External Applicants and Include External Applicants</b>	Select one or both of these check boxes to indicate which types of applicants to include in the recruiting manager metrics. By default, both check boxes are selected.
<b>Hot Jobs Only</b>	Select this check box to exclude job openings that are not hot jobs from the recruiting manager metrics. By default, this check box is deselected.

## Determination of Direct Reports

The system determines the user's direct reports based on the access type specified on the "Target Information Page" (Application Fundamentals). As delivered, the Recruiting Manager Summary page uses the access type By Part Posn Mgmt Supervisor (By Partial Position Management Supervisor).

See "Setting Up Access to Direct Reports Data" (Application Fundamentals).

## Metrics for Direct Reports

<i>Field or Control</i>	<i>Description</i>
<b>Name</b>	Displays the name of the direct report.
<b>Open Jobs</b>	Displays the number of open job openings where the direct report is the primary recruiter. Click the link to access the Browse Job Openings page pre-filtered to show the direct report's open job openings.

<b>Field or Control</b>	<b>Description</b>
<b>Average Days Open</b>	<p>Displays the average number of days that the jobs included in the Open Jobs count have been open. The average is rounded to the nearest whole number.</p> <p>The days open for a job opening is the number of days since the job opening's earliest posting date. If the job has never been posted, the days open is the number of days since the job opening was created. If the earliest job posting date (or, if none, the job creation date) is in the future, the days open is 0.</p>
<b>Applicants in Process</b>	<p>Displays the number of active applicants for the jobs included in the Open Jobs count.</p> <p>Applicants are considered active if they have non-Draft dispositions in any phase other than Reject or Hold.</p>
<b>Applicants per Job</b>	<p>Displays the average number of applicants per job opening based on the values in the Open Jobs field and the Applicants in Process field. The average is rounded to the nearest whole number.</p>
<b>Jobs Filled this Period</b>	<p>Displays how many of the direct report's job openings were filled during the period specified on the page's personalization page. This includes only job openings where the direct report is the Primary Recruiter.</p> <p>Job openings are considered filled when the status changes to the status configured as the "Complete" job opening status. Under the delivered status configuration, this is the 110 Filled/Closed status.</p>
<b>Average Days to Fill Jobs</b>	<p>Displays the average number of Days to Fill for the jobs filled this period. The average is rounded to the nearest whole number.</p> <p>A job opening's Time to Fill is the number of days between the earliest post date for the opening and the date when the job opening is filled. If the job opening was never posted, then Time to Fill is measured from the job opening creation date. If the job was filled before the earliest posting date (or, if the job wasn't posted, before the job creation date), the Days to Fill is zero.</p>

<b>Field or Control</b>	<b>Description</b>
<b>Fill Rate</b>	<p>Displays the direct report's fill rate, which is the Jobs Filled This Period value as a percentage of the number of open jobs during the same period. The fill rate is rounded to the nearest whole number.</p> <p>The number of jobs open during the period includes openings that were open at beginning of period and openings that were opened during the period. Cancelled jobs are removed from the equation.</p>
<b>% Offer Acceptance</b>	<p>Displays the direct report's offer acceptance rate, which is the number of offers accepted as a percentage of the number of offers extended during the same period. The offer acceptance rate is rounded to the nearest whole number.</p>

## Overall Metrics

The Overall Metrics group box displays summary data for all of the recruiting manager's direct reports. The fields are the same as those in the Direct Reports grid, but the values in the grid are aggregated to produce the overall metrics.



## Related Content and Decision Support

If you use PeopleTools 8.55 or later, the Recruiting Manager Summary page includes a supplementary panel that provides access to related information and Simplified Analytics.

For more information about Simplified Analytics, refer to the Simplified Analytics topics in the *PeopleTools: Pivot Grid* documentation.

<b>Field or Control</b>	<b>Description</b>
 (Supplementary Panel button)	<p>Click this icon to open the supplementary panel. The panel displays tabs for <b>Related Information</b> and <b>My Analytics</b>.</p>



<b>Field or Control</b>	<b>Description</b>
<b>Related Information</b>	<p>Click to display a menu listing the pivot grids, then select one of the following pivot grids to display:</p> <ul style="list-style-type: none"> <li>• Job Opening Aging Analysis</li> <li>• Time to Fill Jobs</li> <li>• Jobs Opened/Closed</li> </ul> <p>For more information, see <a href="#">Viewing Recruiting Pivot Grids</a></p> <hr/> <p><b>Note:</b> The pivot grids when accessed from the Recruiting Manager Summary page display data for all of the user’s direct reports rather than just displaying the user’s own data.</p>
 (Personalize Related Content icon)	<p>This icon appears at the top of the Related Information tab. Click to open the Personalize Related Content page. This page lists the available related content so you can choose whether the Related Information tab shows or hides each item.</p>
	<p>This icon appears at the top of each individual item in the Related Information tab. Click to expand the item to open a modal dialog with a larger interactive version of the chart.</p>
<b>My Analytics</b>	<p>The <b>My Analytics</b> tab provides access to the Simplified Analytics capabilities provided by PeopleTools 8.55 and later. Click the plus button to create a new chart, or Click an existing chart to view details.</p> <p>The delivered role <i>PivotGridSuperUser</i> gives users the ability to create and publish reports.</p> <p>This video provides additional information about Simplified Analytics:</p> <p>Video: <a href="#">PeopleSoft HCM 9.2 Image 18 Highlights: Simplified Analytics</a></p>

## Using the PeopleSoft Fluid User Interface to View a Manager’s Open Jobs

This topic discusses how managers use the Open Jobs fluid page to view information about job openings.

For general information about fluid pages in PeopleSoft HCM, see “Understanding PeopleSoft Fluid User Interface Homepages” (Application Fundamentals).

## Pages Used to View a Manager's Open Jobs Using the PeopleSoft Fluid User Interface

<b>Page Name</b>	<b>Definition Name</b>	<b>Usage</b>
<u>Open Jobs Tile</u>	HC_HRS_OPEN_JO_FLU_GBL (cref for the tile)  HRS_OPNJO_TILE_FLU (page for dynamic data)	View the number of open jobs where the current user is the hiring manager..  Tap this tile to access the Open Jobs page.
<u>Open Jobs Page</u>	HRS_OPEN_JO_FLU	View a list of job openings where the current user is the hiring manager.

### Open Jobs Tile

Managers use the Open Jobs tile to view the number of open jobs where the current user is the hiring manager, and to access information about the job openings. This data on the tile comes from the HRS\_OPNJO\_TILE\_FLU page definition.

This example illustrates the Open Jobs tile.

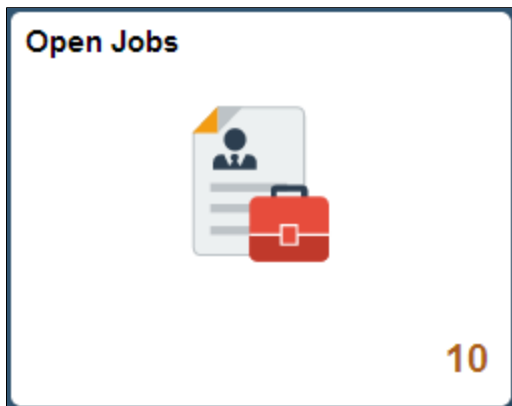

The number on the tile indicates the number of open jobs where the current user is the hiring manager.

Tap the tile to access a list of the job openings.

### Open Jobs Page

Use the Open Jobs page (HRS\_OPEN\_JO\_FLU) to view a list of job openings where the current user is the hiring manager.

Navigation:

Tap the Open Jobs tile on a PeopleSoft Fluid User Interface home page.

The Open Jobs tile is on the delivered Manager Self-Service home page.

This example illustrates the Open Jobs page for the tablet.

Open Jobs				
Job / Location	Category	Days Open	Total Applicants	New Applicants
<b>Eben Director (994488)</b> Ebenefits Texas Loctn	<input type="checkbox"/>	4799	2	0
<b>Clerk-Payroll (300202)</b> Sydney	<input checked="" type="checkbox"/>	1637	1	1
<b>Admin Assistant-290096 (300124)</b> Corporation Headquarters	<input type="checkbox"/>	2669	0	0
<b>Manager-Employee Relations (300123)</b> Delaware Operations	<input checked="" type="checkbox"/>	2669	0	0
<b>Administrative Assistant-10139 (300012)</b> Corporation Headquarters	<input checked="" type="checkbox"/>	5998	0	0
<b>Specialist-Training (290110)</b> Canadian Headquarters	<input type="checkbox"/>	4708	0	0
<b>Janitor (290109)</b> Corporation Headquarters	<input type="checkbox"/>	4708	0	0
<b>Nurse-Head (290108)</b> New Jersey Operations	<input type="checkbox"/>	4708	0	0
<b>Specialist-Customer Services (290107)</b> Oklahoma	<input checked="" type="checkbox"/>	4708	0	0
<b>Consultant-Junior (290106)</b> Oklahoma	<input type="checkbox"/>	4708	2	0
<b>Analyst-Financial Sr (290105)</b> Delaware Operations	<input type="checkbox"/>	4708	4	1
<b>Accountant (290104)</b> Delaware Operations	<input type="checkbox"/>	4708	0	0

This example illustrates the Open Jobs page for the smartphone.

Job / Location	New Applicants
Manager-Accounts Payable (504034) Corporation Headquarters	0 >
Billing Manager - Medical Claims (504024) Corporation Headquarters	1 >
Administrative Assistant (504018) Corporation Headquarters	0 >
Administrative Assistant (Medical Operations) (504005) Corporation Headquarters	1 >
Executive Services Administrator (504004) Corporation Headquarters	0 >
Administrative Support Supervisor (504003) Corporation Headquarters	0 >

Tap anywhere on a job opening to access the [Manage Job Opening Page](#).

### Job Openings

The main grid on this page shows a subset of the information on the [My Job Openings Pagelet](#) on the Recruiting Home dashboard.

<i>Field or Control</i>	<i>Description</i>
<b>Job/Location</b>	The location listed below the job title represent the job opening’s recruiting location rather than its physical location. If a job opening has multiple recruiting locations, the primary location appears.

<b>Field or Control</b>	<b>Description</b>
<b>Category</b>	<p>If job categorization is enabled on the <a href="#">Recruiting Installation – Jobs Page</a>, this column displays category for the job opening. Categories are a personal organizational tool, and your categorization is not visible to other users.</p> <p>You cannot change a job opening’s category from this page. Instead, tap the job opening to access the Manager Job Opening page, and change the category there.</p>
<b>New Applicants</b>	<p>Displays the number of applicants in the Applied phase. To view these applicants, tap the job opening to access the Manage Job Opening page, then tap the <b>Applied</b> phase on the phase filter to show only applicants in the Applied phase.</p>

## Actions

From the Open Jobs page, the main Action menu on the PeopleSoft Fluid User Interface banner includes these page-specific actions

<b>Field or Control</b>	<b>Description</b>
<b>Browse Job Openings</b>	Tap to access the <a href="#">Browse Job Openings Page</a> .
<b>Create Job Opening</b>	Tap to begin the process of creating a job opening.



## Related Content and Decision Support

If you use PeopleTools 8.55 or later, the Open Jobs page includes a supplementary panel that provides access to related information and Simplified Analytics.

For more information about Simplified Analytics, refer to the Simplified Analytics topics in the *PeopleTools: Pivot Grid* documentation.

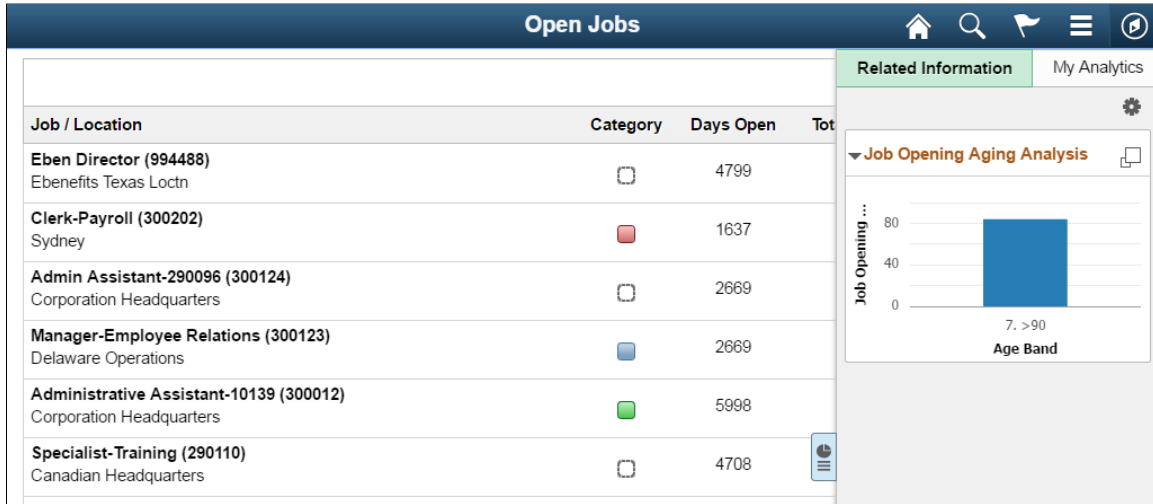
This example illustrates the supplementary panel for the Open Jobs page



<b>Field or Control</b>	<b>Description</b>
 (Supplementary Panel button)	Tap this icon to open the supplementary panel. The panel displays tabs for <b>Related Information</b> and <b>My Analytics</b> .
<b>Related Information</b>	The <b>Related Information</b> tab displays the Job Opening Aging Analysis chart. This chart is a version of the <a href="#">Job Opening Aging Analysis Pivot Grid</a> .
 (Personalize Related Content icon)	This icon appears at the top of the Related Information tab. Click to open the Personalize Related Content page. This page lists the available related content so you can choose whether the Related Information tab shows or hides each item.
	This icon appears at the top of each individual item in the Related Information tab. Click to expand the item to open a modal dialog with a larger interactive version of the chart.

<b>Field or Control</b>	<b>Description</b>
<b>My Analytics</b>	<p>The <b>My Analytics</b> tab provides access to the Simplified Analytics capabilities provided by PeopleTools 8.55 and later. Tap the plus button to create a new chart, or tap an existing chart to view details.</p> <p>The delivered role <i>PivotGridSuperUser</i> gives users the ability to create and publish reports.</p> <p>This video provides additional information about Simplified Analytics:</p> <p>Video: <a href="#">PeopleSoft HCM 9.2 Image 18 Highlights: Simplified Analytics</a></p>

## Using the PeopleSoft Fluid User Interface to View Recruiting Activities as a Hiring Manager

Hiring Managers use the Recruiting Activities tile on the Manager Self Service Homepage to view the navigation collection of the commonly used recruiting pages, specific to their role.

### Pages Used to View Recruiting Activities as a Hiring Manager

<b>Page Name</b>	<b>Definition Name</b>	<b>Usage</b>
<a href="#">Recruiting Activities Tile</a>	HC_HRS_REC_ACTV_FL	Access the Recruiting Activities navigation collection.
<a href="#">Recruiting Activities Page</a>		View a navigation collection of commonly used recruiting pages.
<a href="#">My Job Openings Page</a>	HRS_PE_MY_JOBS_FLU	View a list of job openings for the Hiring Manager.
<a href="#">Search Job Openings Page</a>	HRS_JO_FIND_JOB	Search for job openings using a simple database search.
Create Job Opening: <a href="#">Primary Job Opening Information Page</a>	HRS_JO_LAUNCH	Enter primary job opening information.
<a href="#">Applicant Lists Page</a>	HRS_APPL_LIST	View existing applicant lists.
<a href="#">Interview Calendar Page</a>	HRS_INT_CLNDR	See a weekly schedule of your own interviews.

<b>Page Name</b>	<b>Definition Name</b>	<b>Usage</b>
Recruiting Alerts		View the alert types available for Hiring Managers. Click any alert type, to access the corresponding page for details.

## Recruiting Activities Tile

Hiring Managers use the Recruiting Activities tile (cref for the tile: HC\_HRS\_REC\_ACTV\_FL) to access the Recruiting Activities navigation collection.

Navigation:

The Recruiting Activities tile is on the delivered Fluid Manager Self Service Homepage.

This example illustrates the Recruiting Activities tile.



## Recruiting Activities Page

Hiring Managers use the Recruiting Activities page to view a navigation collection of commonly used recruiting pages, such as, My Job Openings, Search Job Openings, Create Job Opening, Applicant Lists, Interview Calender and Recruiting Alerts.

Navigation:

Click the Recruiting Activities tile on the Fluid Manager Self Service Homepage.



This example illustrates the Recruiting Activities Navigation Collection page for Hiring Managers.

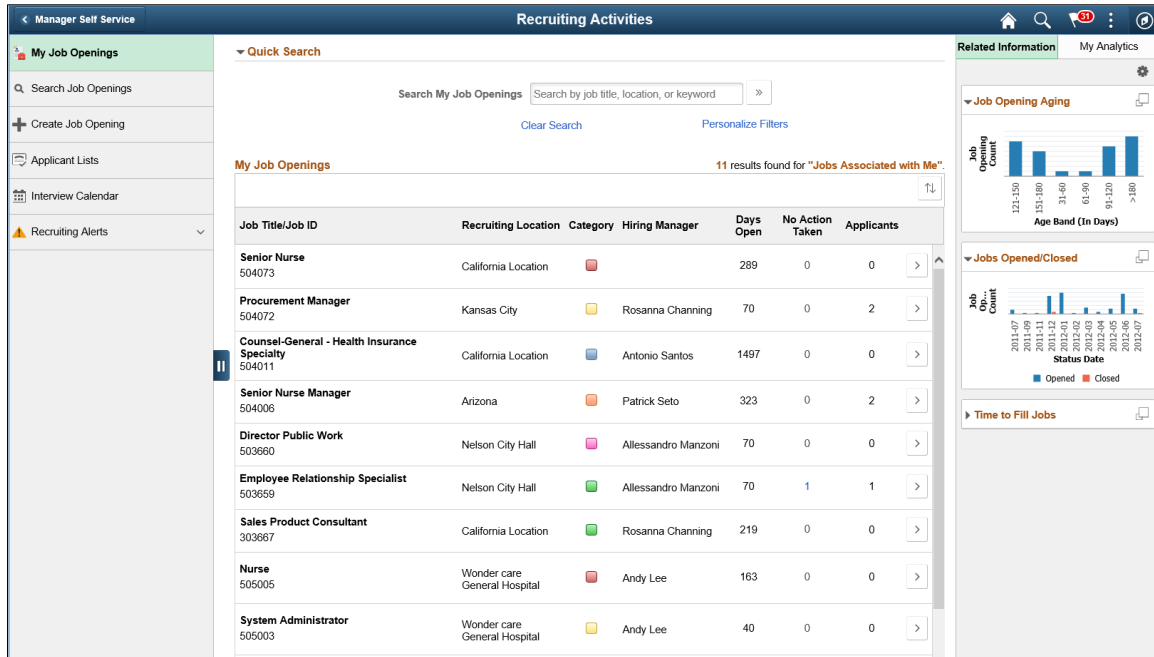



Here the navigation collection provides access to the following components:

- My Job Openings
- Search Job Openings
- Create Job Opening
- Applicant Lists
- Interview Calendar
- Recruiting Alerts

If you use PeopleTools 8.55 or later, this page also includes a supplementary panel that provides Hiring Managers access to related information and Simplified Analytics.

<b>Field or Control</b>	<b>Description</b>
 <p>(Supplementary Panel button)</p>	<p>Click this icon to open the supplementary panel. The panel displays tabs for <b>Related Information</b> and <b>My Analytics</b>.</p>
<p><b>Related Information</b></p>	<p>The <b>Related Information</b> tab displays charts for Job Openings Aging, Jobs Opened/Closed and Time to Fill Jobs. These charts are versions of the <u>Job Opening Aging Analysis Pivot Grid</u>, <u>Job Opening Open and Close Trend Pivot Grid</u> and <u>Time to Fill Pivot Grid</u>.</p>

<b>Field or Control</b>	<b>Description</b>
 (Personalize Related Content icon)	This icon appears at the top of the Related Information tab. Click to open the Personalize Related Content page. This page lists the available related content so you can choose whether the Related Information tab shows or hides each item.
	This icon appears at the top of each individual item in the Related Information tab. Click to expand the item to open a modal dialog with a larger interactive version of the chart.
<b>My Analytics</b>	<p>The <b>My Analytics</b> tab provides access to the Simplified Analytics capabilities provided by PeopleTools 8.55 and later. Click the plus button to create a new chart, or click an existing chart to view details.</p> <p>The delivered role <i>PivotGridSuperUser</i> gives users the ability to create and publish reports.</p> <p>This video provides additional information about Simplified Analytics:</p> <p>Video: <a href="#">PeopleSoft HCM 9.2 Image 18 Highlights: Simplified Analytics</a></p>

## Recruiting Alerts for Hiring Managers

The **Recruiting Alerts** collapsible section on the left panel displays the alert types available for Hiring Managers. Click any alert type, to access the corresponding page for details.

This example illustrates the fields and controls on the Recruiting Alerts collapsible section for Hiring Managers. You can find definitions for the fields and controls later on this page.

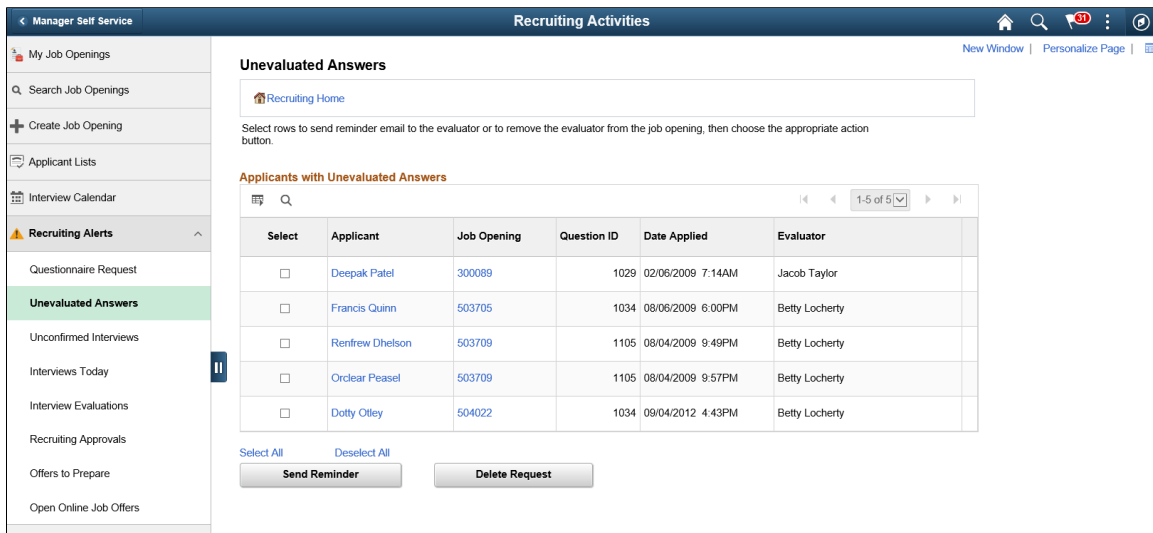

**Unevaluated Answers**

Select rows to send reminder email to the evaluator or to remove the evaluator from the job opening, then choose the appropriate action button.

**Applicants with Unevaluated Answers**

Select	Applicant	Job Opening	Question ID	Date Applied	Evaluator
<input type="checkbox"/>	Deepak Patel	300089	1029	02/06/2009 7:14AM	Jacob Taylor
<input type="checkbox"/>	Francis Quinn	503705	1034	08/06/2009 6:00PM	Betty Locherty
<input type="checkbox"/>	Renfrew Dhelson	503709	1105	08/04/2009 9:49PM	Betty Locherty
<input type="checkbox"/>	Orclear Peasel	503709	1105	08/04/2009 9:57PM	Betty Locherty
<input type="checkbox"/>	Dotly Otley	504022	1034	09/04/2012 4:43PM	Betty Locherty

Select All    Deselect All

<b><i>Alert Label</i></b>	<b><i>Description</i></b>	<b><i>Page Accessed</i></b>
<b>Questionnaire Request</b>	<p>Displays the applicants who have not yet submitted updated applications for job openings with questionnaires after being invited to do so.</p> <p>Only applicants who are linked to currently open job openings are included.</p> <p>See <a href="#">Linking Applicants to Job Openings</a>.</p>	<p><a href="#">Questionnaire Requests Page</a></p> <p>Use this page to review open questionnaire requests and to send email reminders to selected applicants.</p>
<b>Unevaluated Answers</b>	<p>Displays the open-ended screening question evaluations that have not been completed for the user's job openings.</p>	<p><a href="#">Unevaluated Answers Page</a></p> <p>Use this page to see the applicants, job openings, and evaluators for the incomplete evaluations.</p>
<b>Unconfirmed Interviews</b>	<p>Displays the unconfirmed interviews where the user is an interviewer.</p>	<p><a href="#">Unconfirmed Interviews Page</a></p> <p>Use this page to see the list of unconfirmed interviews.</p>
<b>Interviews Today</b>	<p>Displays the interviews scheduled for the user on that specific day.</p>	<p><a href="#">Interview Calendar Page</a></p> <p>Use this page to review the Hiring Manager's weekly interview schedule.</p>
<b>Interview Evaluations</b>	<p>Displays the incomplete interview evaluations where the user is the evaluator. Two types of evaluations are included:</p> <ul style="list-style-type: none"> <li>• Evaluations that were saved as draft but not submitted.</li> <li>• Evaluations that have not been started for an interview that has already occurred (based on the interview date).</li> </ul>	<p><a href="#">Interview Evaluations Page</a></p> <p>Use this page to review and act on the incomplete evaluations.</p>

<b><i>Alert Label</i></b>	<b><i>Description</i></b>	<b><i>Page Accessed</i></b>
<b>Recruiting Approvals</b>	<p>Displays the job offers and job openings waiting for the Hiring Manager's approval.</p> <p>If approval authority is delegated to a proxy who has access to the Recruiting Alerts page, the delegated transactions are included in the proxy's count (and not the delegator's count) during the delegation period.</p>	<p><u><a href="#">Pending Approvals Page</a></u></p> <p>Use this page to review and act on the job offers and openings that require the Hiring Manager's approval.</p>
<b>Offers to Prepare</b>	<p>Displays the applications that:</p> <ul style="list-style-type: none"> <li>• Have a draft (unsubmitted) offer.</li> <li>• Are in the Interview phase with an Interview status that is the designated "Complete" status. As delivered, the complete status for interviews is 020 Make Offer.</li> <li>• Are in the Offer phase, but no offer record exists. This occurs only when a user manually changes an applicant's disposition using the Edit Disposition action.</li> </ul>	<p><u><a href="#">Offers to Prepare Page</a></u></p> <p>Use this page to review applicants who are waiting for offers and to access the applicant or job opening so that the Hiring Manager can begin to prepare the offer.</p>
<b>Open Online Job Offers</b>	<p>Displays the expired or soon-to-expire open online job offers for your job openings. This includes offers that will expire within the number of days that you specify on the Personalize Recruiting Alerts page.</p> <p>Open online job offers are offers that you posted to Candidate Gateway that have not been accepted or rejected. The offer status must be Extend.</p>	<p><u><a href="#">Open Online Job Offers Page</a></u></p> <p>Use this page to review the applicants and job openings associated with the open online job offers.</p>

## **Related Links**

[Using the PeopleSoft Fluid User Interface to View Recruiting Alerts](#)  
[Viewing Detail Pages for the My Alerts Pagelet](#)

## Chapter 16

# Creating Job Openings

---

## Understanding Job Openings

This topic discusses:

- Job opening creation methods.
- Configurable display of job opening data.
- The Create Job Opening page and the Manage Job Opening page

## Job Opening Creation Methods

There are three methods of creating job openings:

- Manually enter job opening data in the Create Job Opening component, starting on the [Primary Job Opening Information Page](#) and continuing to the [Job Opening Page](#).

Entering certain required information on the Primary Job Opening Information page enables the system to assign a recruitment template and, if applicable, a flexible job creation process for the job opening. When you continue to the main Job Opening page, the recruitment template and the flexible job creation process control the page layout.

- Clone an existing job opening using the [Clone Job Opening Page](#).
- Use the [Create Job Openings from Positions Page](#) to run the Create Job from Position Application Engine process (HRS\_CRJOB).

---

**Note:** Generally, users who can access an existing job opening can create a new job opening using either the Create New or Clone toolbar buttons on the Manage Job Opening page. However, if the authority to approve job openings is delegated to a proxy, a proxy who does not belong to a recruiting role is able to access the job opening but cannot see either the Create New or Clone buttons.

---

## Recruitment Templates and the Configurable Display of Job Opening Data

Every job opening is associated with a recruitment template that brings together various other templates to control the content and layout of job opening-related pages. The [Recruiting Installation - General Page](#) specifies system-wide default templates as well as a segmenting type field that can be used to assign different recruitment templates to job openings with specific data. For example, if the segmenting type field is *Department*, then specific departments can be associated with specific recruitment templates, and job openings with those departments are assigned the department-specific recruitment template.

Data for the segmenting type field is always entered before you access the main Job Opening page, enabling the system to assign the recruitment template before you access the Job Opening page. Only recruitment administrators can override this assignment.

The recruitment template is associated with a job opening template that identifies sections to include on the Job Opening page. The job opening template also organizes the sections under tabs that you define.

For a complete list of possible sections, refer to the documentation for the [Job Opening Page](#).

During the job creation process, specific fields within a section can optionally be hidden from users with certain roles. Use a flexible job creation process to configure this behavior.

Typically, you use the flexible job creation process to limit which fields are visible to hiring managers. This configuration allows managers to focus on a subset of information without being distracted or confused by fields that a recruiter will complete. The fields remain hidden while the job opening is unsaved or in Draft status. When the job is opened or submitted for approval, all users including hiring managers can view the complete job opening data.

### Related Links

[Setting Up Recruitment Templates](#)

[Setting Up Job Opening Templates](#)

[Setting Up Flexible Job Creation Processes](#)

## The Create Job Opening Page and the Manage Job Opening Page

The Job Opening page (HRS\_JOB\_OPENING) is the main data entry page for job opening details. This page appears when you create a new job opening or when you access an existing job opening that is in either Draft, Pending Approval, or Denied status.

However, when you access an existing job that is (or was) in Open status, it appears on the Manage Job Opening page (HRS\_JO\_360). On this page, additional tabbed sections and toolbar buttons enable you to manage the recruiting process. The job opening data that you entered on the Job Opening page is consolidated under a Details tab.

This illustration shows that the tabs on the Job Opening page are rendered on the Manage Job Opening page as subsection links under the Details tab.

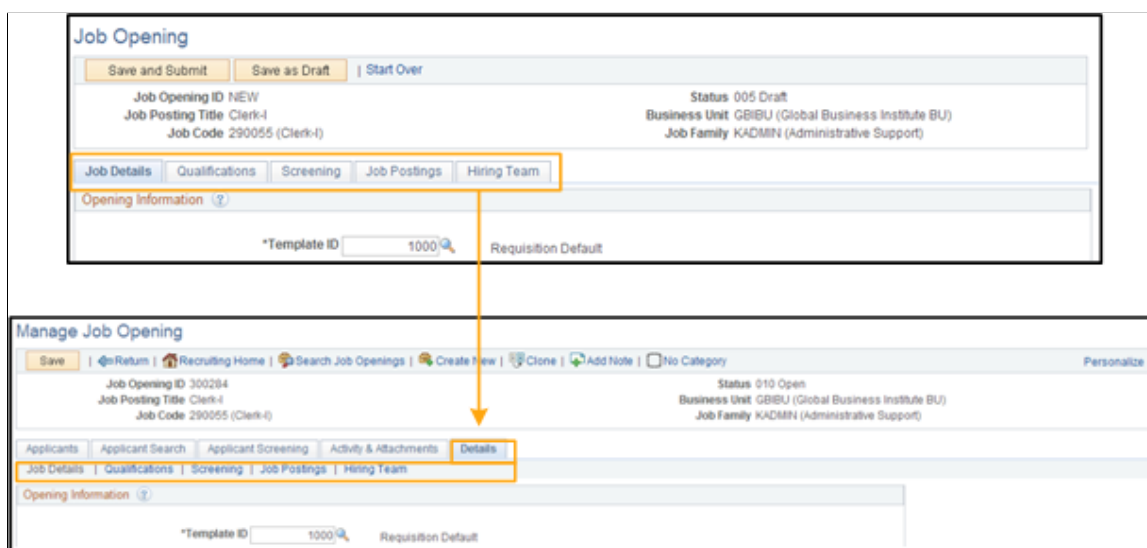

When you click the Details tab on the Manage Job Opening page, the system is actually displaying the Job Opening page rendered to match the look and feel of the Manage Job Opening page.

## Understanding Profile Integration for Job Openings

This overview discusses:

- Profile architecture.
- Profile integration options.
- Data loaded from profiles

### Profile Architecture

You create and manage profiles using the Manage Profiles business process in PeopleSoft Human Resources. To understand profile integration for job openings, you must be familiar with profile architecture, including these terms:

<b>Term</b>	<b>Definition</b>
Profile	An organized collection of data that represents attributes of a person or of a business object such as a job. Typically, profiles summarize the competencies, qualifications, and skills of a job or a person.
Content Type	A category of information in a profile. Delivered content types that support recruiting processes include competencies, languages, memberships, degrees, licenses & certificates, and so forth.
Content Item	A specific attribute that is associated with a particular content type. For example, for the content type <i>Competencies</i> , content items are specific competencies such as analytical thinking or the ability to prioritize tasks.
Instance Qualifier	A value that is used to organize and filter content items. For example, competency ratings are organized according to the evaluation type (self-evaluation, manager evaluation, and so forth). This is possible because the evaluation type is being used as an instance qualifier.
Profile Type	<p>Profile types define the structure of your profiles. A profile type includes content types, but not content items. That is, a particular profile type might include content types such as competencies and memberships, but it does not reference particular competencies or particular memberships.</p> <p>The profile type also defines whether the profile is linked to person IDs to create person profiles, or linked to business entities, such as job code or positions, to create non-person profiles.</p>

<b>Term</b>	<b>Definition</b>
<p>Primary Person Profile Type</p>	<p>A specific person profile type that you select on the Assign Profile Defaults page. The system uses this profile type to identify the content types that are available for use in Talent Acquisition Manager.</p> <p>Although all content types in the primary person profile type are available for use, you can configure the system to use a subset of the content types on specific pages:</p> <ul style="list-style-type: none"> <li>• The <u>Content Section Configuration – &lt;Content Type&gt; Page</u> controls which content types are available to use in resume templates and job opening templates.</li> </ul> <p>It also controls the content type properties that are available for use in screening.</p> <ul style="list-style-type: none"> <li>• Resume templates control which the content types appear to applicants who apply online using Candidate Gateway.</li> <li>• Job opening templates control which content types appear on the Job Opening page.</li> <li>• All of the content types appear on the <u>Application Details Page</u>, where you enter profile information that might be applied to any job opening.</li> </ul>

## Profile Integration Options

When creating job openings, you can automatically populate the profile-based job qualifications with content items from selected profiles.

For example, when replacing a key employee, you can copy attributes such as competencies and languages from the employee's profile into the job opening. Similarly, you can pull requirements from a job profile. You can even combine requirement sources by selecting multiple profiles from which to load requirements.

The recruiting system provides two layers of profile integration:

- *Standard profile integration* enables users to explicitly select person and non-person profiles to load.
 

The option to explicitly select non-person profiles is always available if profile integration is active, but a separate configuration setting enables you to choose whether to also allow users to explicitly select person profiles.
- *Expanded profile integration* enables the system to identify job profiles to load based on the job code, position number, job family, or salary grade of the job opening.

If you activate this option, you choose which job opening field the system uses when identifying profiles to load. The setting for this option is in the recruitment template and can therefore vary depending on the job opening.



## Profile Integration Configuration

Activate standard profile integration on the [Recruiting Installation - General Page](#).

The **Allow Profile Utilization** field on this page is the control switch for profile integration. Set the value to *Yes* to activate profile integration. When this option is turned on, users are able to explicitly choose non-person profiles to import into the job opening.

If profile integration is active, the **Allow Person Profile Integration** field on the same page becomes editable. Set this value to *Yes* to allow users to explicitly identify person profiles as well as non-person profiles

Activate expanded profile integration on the [Recruitment Template Page](#). Use the **Load Rqmts from Job Profile** (Load Requirements from Job Profile) drop-down list box to choose the specific job opening field from which profile data is pulled (job code, position number, job family, or salary grade). If you do not want to activate expanded profile integration, select *Not Used*.

---

**Important!** Expanded profile integration is available only if standard profile integration is active. When standard profile integration is off, the **Load Rqmts from Job Profile** field remains editable, but the settings are ignored.

---

## Process Flow for Standard Profile Integration

A user who creates a job opening starts on the Primary Job Opening Information page. Under standard profile integration, this page displays the fields where users can explicitly identify profiles to load.

If the user selects any profiles, then before the system displays the job opening, the Combined Profile Information page displays a preview of the data to be imported. After reviewing the data, users can decide whether to continue to the job opening or return to the previous page to change the profile selection.

This diagram illustrates the process of explicitly selecting profiles, previewing their content, and adding the content to the job opening:

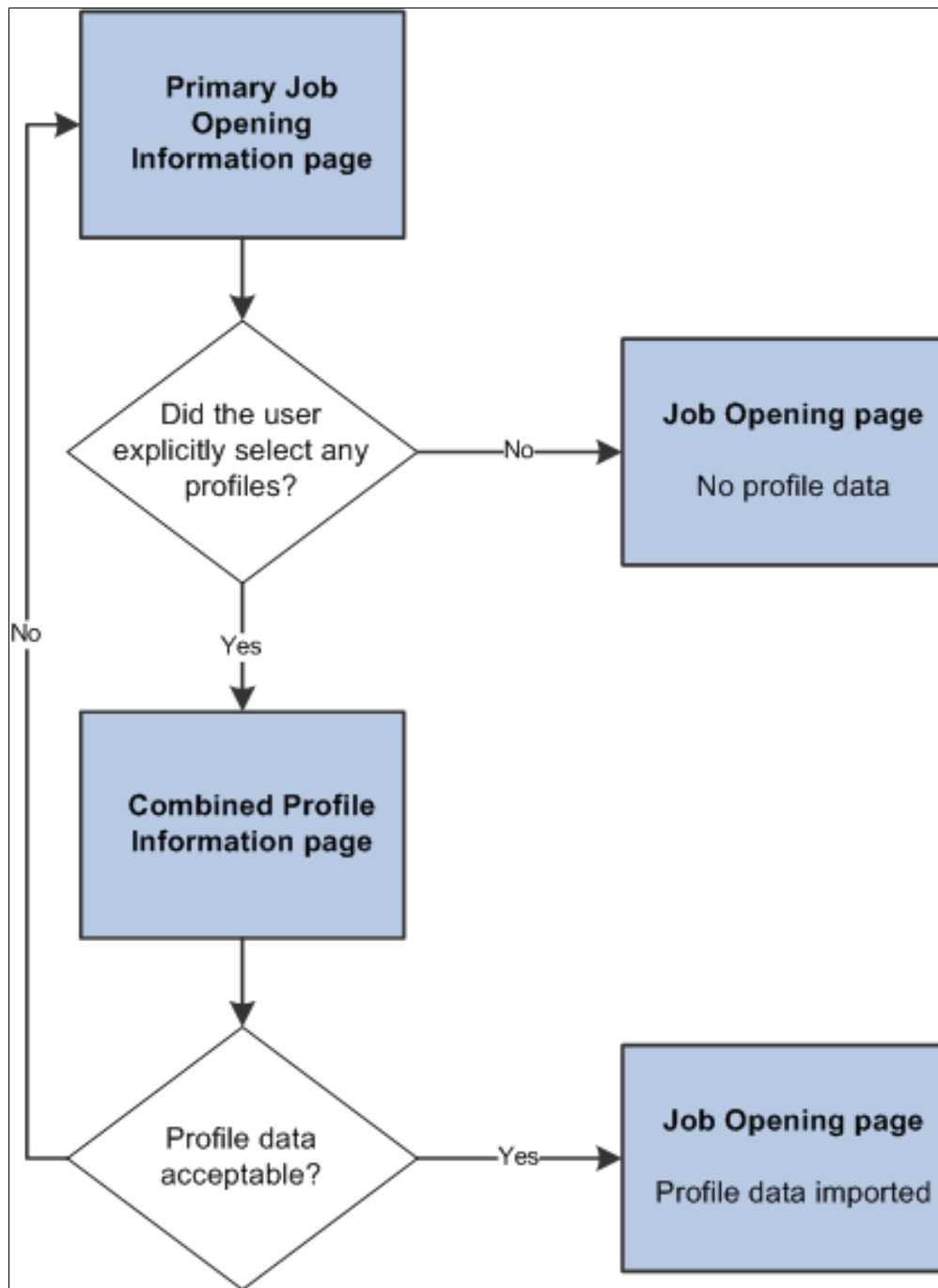

---

**Note:** If you segment your job openings by job profile, there is an additional Job Profile field on the page, separate from the grids where you otherwise identify profiles to use. If you segment by job profile, this is a required field, and the profile you enter is also imported into the job opening.

---

### Process Flow for Expanded Profile Integration

Under expanded profile integration:

- The system imports data from explicitly identified profiles, just as it does under standard profile integration.
- The system also identifies profiles that are associated with the job code, job family, position, or salary grade for the job opening, and it gives the user an option to import these profiles as well.

The type of job opening data that is used for the expanded profile integration is based on the setting in the **Load Rqmts from Job Profile** field on the recruitment template. To import data based on job family or salary grade data, you must use job family or salary grade as the segmenting type. Otherwise, users are not able to enter the specified data on the Primary Job Opening Information page.

Under expanded profile integration, the system always asks users to verify that they want to load the profile data that is associated with the job opening data. (Explicitly identified profiles are always loaded, regardless of whether the user chooses to also load the associated profiles.)

This diagram illustrates the expanded profile integration process flow. In this flow, users must verify that they want to load the profiles that are associated with the job opening data. The Combined Profile Information page appears if either explicitly identified profiles or associated profiles are loaded.

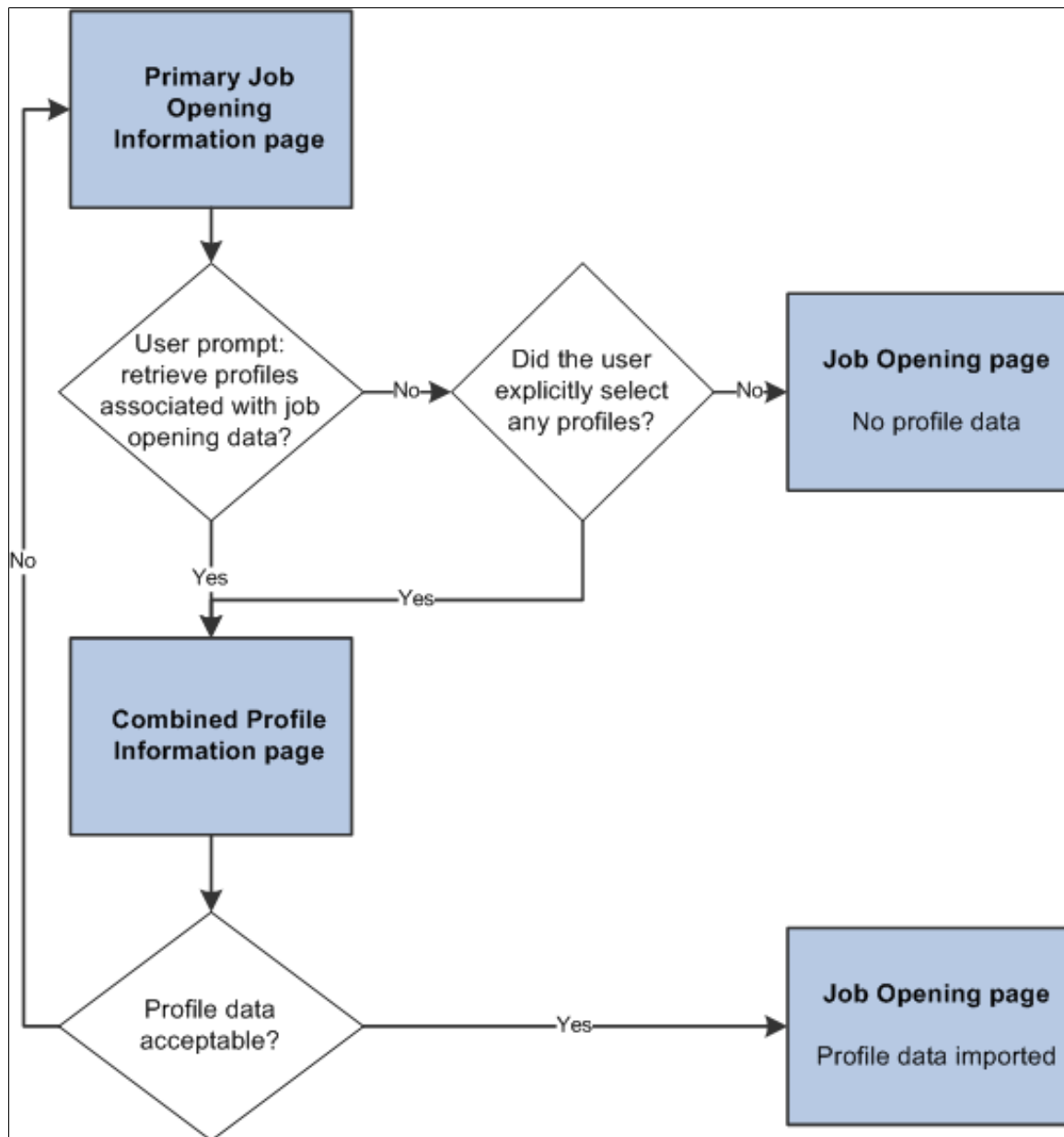

## Data Loaded from Profiles

This topic discusses the data that is brought into job openings from profiles.

### Content Item Selection

When the system imports profile data, it copies only the content items for the content types that are included in the job opening template. For example, if the job opening has sections for competencies and degrees, but not for language skills, then any language skills in the source profile are not copied to the job.

The system copies content items only if the content type structure is the same in the source profile and in the primary person profile type. Additionally, only content items with the same instance qualifier setup as the primary person profile type are copied. For example, if you select a nonperson JOB profile to copy, but its instance qualifiers for competencies are different from those in the primary person profile type, then any competencies associated with the JOB profile are not copied into the job opening.

---

**Note:** When copying content items with instance qualifiers, the system copies only items with instance qualifiers that are viewable by employees. The ability for employees to view specific instance qualifiers is part of the instance qualifier setup in the Manage Profiles business process.

---

This diagram illustrates the consolidation of content items from the source profiles into the job opening. In the diagram, the system copies data from two profiles into the job opening. Competencies from both profiles are added to the job opening, and each competency in the job opening retains information about the profile from which it came.

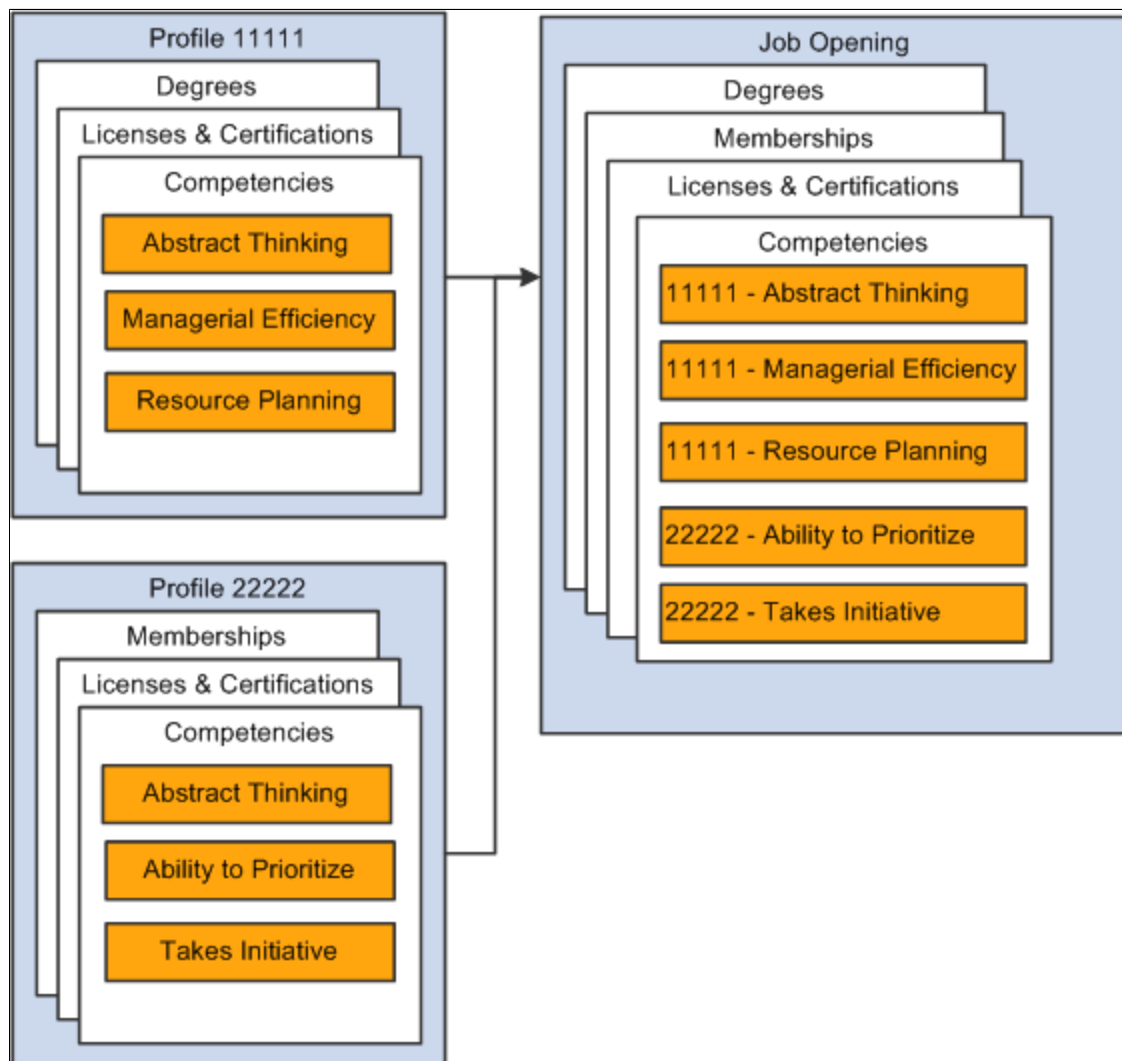

---

**Note:** Content items that exist in multiple source profiles are added to the job opening only once. If one profile has a version with a later effective date, then the system brings that later version and its Profile ID into the job opening.

---

## Limiting Content Items Based on Instance Qualifiers

Profile architecture uses the concept of an *Instance Qualifier* to organize content types according to specified data.

For example, in the case of competencies, the evaluation type (self-evaluation, manager evaluation, and so forth) is the instance qualifier. The instance qualifier setup for competencies not only lists the evaluation types, it indicates which ones employees can view (for example, employees can view manager evaluations, but not peer evaluations), and which one is the default value for employees (for competencies, *Self* is the employee default).

Talent Acquisition Manager processes job opening content items with instance qualifiers according to these rules:

- Content items are copied only if the instance qualifier configuration for the source profile's profile type matches the instance qualifier configuration for the primary person profile type.

For example, if the primary person profile type uses the evaluation type as an instance qualifier for competencies, then the system copies competency content items only from profiles that also use the evaluation type as an instance qualifier.

---

**Note:** Be sure that the Primary Person Profile Type and any non-person profile types that you use in Recruiting have the exact same instance qualifier setup, including marking the same instance qualifiers as required. If an instance qualifier is required in the Primary Person Profile Type but not in the imported profile type (for example, JOB), then the imported content item might be lacking a qualifier that is required in the job opening, and you will not be able to save the job opening.

---

- When the system copies content items into a new job opening, it copies only items that are visible to employees.

For example, competency ratings with the evaluation type *Peer* are not copied to the job opening.

- When the system copies content items into a new job opening, it copies only the latest effective-dated content items in the profile are copied.

For example, if an employee enters annual self-evaluations for competencies, the content item representing the most recent self-evaluation is copied into the job opening.

- When a content type is used in screening, the description of the content items shows the instance qualifier.

For example, if the Competencies grid in a job opening includes two rows for analytical thinking, one row for a self-evaluation and one row for a supervisor/manager evaluation, then when you set up screening for the job opening, the list of available screening requirements includes two rows for the analytical thinking competency, one row where the description shows that this is for a Supervisor/Manager proficiency rating, and one where the description shows that it is for a Self proficiency rating.

- When the system loads content items from a job opening into the Candidate Gateway application form (because the Content Section Configuration page is configured to prevent applicants from adding items themselves), it loads only items that are visible to employees.

For example, if a Job Opening has four competencies, and the first two have the evaluation type *Self* and the last two have the evaluation type *Official*, only the first two items appear in the Candidate Gateway online application form.

---

**Note:** Under the delivered configuration, competency evaluation types and ratings are included when you add a competency to a job opening, but the rating is informational only. That is, the screening process does not check if the applicant has the rating that appears in the job opening. Instead, the screening process awards applicants points based on the applicant's rating and the points scale that you establish in the screening criteria. You can, however, configure the system to screen for a specific rating (for example, to check whether the applicant has a self-evaluation proficiency of *Excellent* for a particular competency).

---

## The Primary Profile and Profile Updates

Job openings retain an association with the profiles whose data is imported. One of the profiles must be designated as the primary profile. The grid where you designate the primary profile is always visible on the Combined Profile Information page. It is visible in the job opening only if the job opening template includes the Profile Details section.

Any content items that you manually add to the job opening are associated with the primary profile, unless there is a profile type configuration incompatibility, in which case the profile ID for the new content item is 0. (The system also assigns a profile ID of 0 when there are no profiles associated with the job opening.)

For example, when you create a job opening, the hiring manager might provide updated requirements that you can then transfer back to the job profile, maintaining consistency and eliminating redundant work efforts.

If the primary profile is a non-person profile, you can optionally update the profile based on changes you make to the job opening data. Activate this option by selecting the **Updates Allowed** check box in the same grid where you designate the primary profile.

---

## Creating Job Openings

This topic provides an overview of primary job opening information and discusses the pages that you use to create a job opening.

### Pages Used to Create Job Openings

<i>Page Name</i>	<i>Definition Name</i>	<i>Usage</i>
<a href="#">Primary Job Opening Information Page</a>	HRS_JO_LAUNCH	Enter primary job opening information.
<a href="#">Combined Profile Information Page</a>	HRS_JO_PRFL_PRVW	Review the profile characteristics that are being brought into the job opening.
<a href="#">Job Opening Page</a>	HRS_JOB_OPENING	Enter job opening details.

<b>Page Name</b>	<b>Definition Name</b>	<b>Usage</b>
<u>Send Notification Page</u>	HRS_JO_SEND_EMAIL	Send notifications from the context of a draft job opening.

## Understanding Primary Job Opening Information

When you create a job opening, you start by entering certain high-level information on the Primary Job Opening Information page. The data that you enter here determines which templates govern the job opening and which profiles supply default qualifications for the job opening.

### Template Selection

Data on the primary Primary Job Opening page drives the selection of a recruitment template for the job opening. Selection of a recruitment template is governed by the segmenting type and template defaults specified on the [Recruiting Installation - General Page](#). A field corresponding to the selected segmenting type always appears on the Primary Job Opening Information page, and you are required to enter a value in that field. This enables the system to apply the appropriate recruitment template.

For example, if your job openings are segmented by department, then the Primary Job Opening Information page displays a required **Department** field. If there is a recruitment template associated with the department you enter, then the system uses that template. Otherwise, the job opening uses the system's default template. You identify separate default templates for standard requisitions and for continuous job openings.

A job opening's recruitment template controls the content and layout of various job opening pages. These recruitment template-controlled items are of particular interest when you are creating a job opening:

- The job opening template.

This controls which sections appear on the main Job Opening page and how those sections are organized under configurable tabs.

- The flexible process template group and, by extension, the flexible job creation process.

The recruitment template, in conjunction with predefined “driver fields” that also appear on the Primary Job Opening Information page, controls which flexible job creation process governs the job opening. The flexible job creation process hides selected fields from users with specified recruiting roles.

### Profile Selection

If profile integration is active, Primary Job Opening Information page displays grids where users can explicitly identify profiles whose data is to be imported into the job opening.

Additionally, if the recruitment template is configured to load profile data, the system gives users the option to import the profile data that is associated with one of the other fields on the page. The recruitment template can be configured to load data from the job code, position, salary grade, or job family.

If the user indicates that profile data should be imported (by explicitly entering profiles, by answering yes when asked whether to import associated profiles, or both), continuing on from the Primary Job Opening



Information page brings the user to the Combined Profile Information page. After reviewing the profile items to be brought into the job opening, users can continue to the main Job Opening page.

## Primary Job Opening Information Page

Use the Primary Job Opening Information page (HRS\_JO\_LAUNCH) to enter primary job opening information.

Navigation:

**Recruiting > Create Job Opening**

This example illustrates the Primary Job Opening Information page.

**Primary Job Opening Information**

[🏠 Recruiting Home](#)

**Job Details** ?

Job Opening Type

\*Business Unit  Q Global Business Institute BU

\*Job Family  Q Finance

Department  Q Human Resources

Position Number

Job Code  Q Accountant

\*Recruiting Location  Q United States

\*Job Posting Title

**Profile Details** ?

**Person Profile** ?

Employee ID	View Profile	
<input type="text" value="K0G001"/> <span style="font-size: 0.8em;">Q</span>	<a href="#">Rebekah Jones</a>	

[Add Person Profile](#)

**Job Profile** ?

Profile ID	View Profile	
<input type="text" value="100665"/> <span style="font-size: 0.8em;">Q</span>	<a href="#">Human Service Professionals</a>	

[Add Job Profile](#)

Continue

### Job Details

**Note:** The driver fields for flexible templates are Business Unit, Job Family, Job Code, Department, and Recruiting Location (which represents the primary recruiting location). The Job Family field appears only if it is the segmenting type specified on the Recruiting Installation - General page.

<b>Field or Control</b>	<b>Description</b>
<b>Job Opening Type</b>	<p>Select whether this is a <i>Standard Requisition</i> or a <i>Continuous Job Opening</i>. You cannot change the type after you move on to the Job Opening page.</p> <p>A standard requisition is for a specific job or position that you want to fill. You must provide specific data regarding the job or position code. Standard requisitions can represent multiple job codes if you've configured the Recruiting Installation - Jobs page to allow this.</p> <p>A continuous job opening represents a job for which your organization is always hiring. This type of job opening can be used as a placeholder for possible candidates and can potentially remain open for an indefinite amount of time. Continuous job openings are not used in Time to Fill reporting.</p> <p>Continuous job openings require only a job posting title. They do not require a job code or position number.</p>
<b>Business Unit</b>	<p>Select the business unit associated with the job opening.</p> <p>A user's default business unit is based on the primary permission list assigned to the user ID. The default business unit for that permission list is specified on the "Org Defaults by Permission Lst - Defaults Page" (Application Fundamentals).</p> <p>The business unit controls the available values for various business unit-controlled or setID-controlled job opening fields such as position number, job code, location, and recruiting location.</p> <p>The business unit does not control values for the profiles that you enter in Person Profile grid and the Job Profile grid, but it does filter the profile identities (job codes, positions, and so forth) that the system brings from the profiles into the job opening.</p>
<b>Department</b>	Select the department associated with this job opening.

<b>Field or Control</b>	<b>Description</b>
<b>Position Number</b>	<p>Optionally select the position number for the job opening. This field appears when <b>Position Management Option</b> on the “HCM Options Page” (Application Fundamentals) is set to <i>Full</i> or <i>Partial</i>.</p> <p>When job openings are segmented by business unit, department, job family, or job profile, you must enter a segmenting value before entering a position, as the segmenting value (along with the business unit) controls which positions are available for selection.</p> <p>When job openings are segmented by company, job code, or salary grade, you can select a position without first entering a segmenting value.</p>
<b>Job Code</b>	<p>Select the job code associated with this job opening.</p> <p>For continuous job openings, this field is optional, even if job openings are segmented by job code.</p> <p>For standard requisition job openings, this field is required if the <b>Position</b> field is blank. If the <b>Position</b> field contains a value, the system derives the job code from the position number.</p>
<b>Recruiting Location</b>	<p>Select the primary recruiting location associated with this job opening. You can enter additional recruiting locations on the main Job Opening page.</p>
<b>Posting Title</b>	<p>Enter an initial primary posting title. The system uses the primary posting title to identify the job opening on various pages throughout the system. The primary posting title is also the default title when you create job postings. After you have created one or more job postings for the job opening, you can change the primary posting title by selecting a posting to use for that purpose.</p>

### Additional Job Details Based On Segmenting Type

The Primary Job Opening Information page always displays a required field for the template segmenting type. This page already includes fields for many of the segmenting type options, but the following fields appear only when they are used as the segmenting value:

<b>Field or Control</b>	<b>Description</b>
<b>Company</b>	<p>This field appears when the <b>Template Segmenting Type</b> field on the Recruiting Installation - General page is set to <i>Company</i>.</p> <p>Select the company associated with the job opening.</p>
<b>Job Family</b>	<p>This field appears when the <b>Template Segmenting Type</b> field on the Recruiting Installation - General page is set to <i>Job Family</i>.</p> <p>Select the job family associated with this job opening.</p>
<b>Job Profile</b>	<p>This field appears when the <b>Template Segmenting Type</b> field on the Recruiting Installation - General page is set to <i>Job Profile</i>.</p> <p>Select the job profile that is associated with this job opening. Available profiles include non-person JOB profiles.</p>
<b>Salary Admin Plan</b> (salary administration plan) and <b>Salary Grade</b>	<p>These fields appear when the <b>Template Segmenting Type</b> field on the Recruiting Installation - General page is set to <i>Salary Grade</i>.</p> <p>Select the salary administration plan and salary grade that are associated with this job opening.</p>

## Profile Details

If the **Allow Profile Utilization** field on the Recruiting Installation - General page is set to *Yes*, the Profile Details group box appears on the Primary Job Opening Information page. Use the grids in this group box to select profiles to import into the job opening.

---

**Note:** You can enter a maximum of three profile IDs on this page using any combination of the Person Profile grid, the Job Profile grid, and any profile that is loaded based on recruitment template settings. For example, if the recruitment template is configured to load the profile for the job code, and you enter a job code that has a profile, then that profile counts toward the limit of three profiles per job opening.

---

<b>Field or Control</b>	<b>Description</b>
<b>Person Profile</b>	<p>This grid appears only if the <b>Person Profile Integration</b> field on the Recruiting Installation - General page is set to <i>Yes</i>.</p> <p>Enter the employee IDs for the people whose profile data you want to bring into the job opening. Profile security applies: administrators can select any profile, other users can select only their own profile and the profiles of their direct reports.</p> <p>The <b>View Profile</b> link displays the name of the person whose employee ID you entered. Click the link to access the “Person Profile Page” (PeopleSoft Human Resources Manage Profiles) so that you can preview the characteristics of the selected profile.</p>
<b>Job Profile</b>	<p>Enter the profile IDs for the job profiles whose data you want to bring into the job opening.</p> <p>You can select non-person profiles with any profile type.</p> <p>The <b>View Profile</b> link displays the name of the profile you entered. Click the link to access the “Non-person Profile Page” (PeopleSoft Human Resources Manage Profiles) so that you can review (though not update) the characteristics of the selected profile.</p>

### Continue Button

<b>Field or Control</b>	<b>Description</b>
<b>Continue</b>	<p>Click this button to continue creating the job opening.</p> <p>If the recruitment template is configured to load profile data from one of the job opening fields, a message appears asking if you want to load profile data. If you answer yes, or if the Primary Job Opening Information page explicitly identified profiles to load, the system displays the Combined Profile Information page after you click the Continue button. Otherwise, the system takes you directly to the Job Opening page.</p>

### Combined Profile Information Page

Use the Combined Profile Information page (HRS\_JO\_PRFL\_PRVW) to review the profile characteristics that are being brought into the job opening.

Navigation:

Click the **Continue** button on the [Primary Job Opening Information Page](#).

This page appears only if profile integration is active and the system has identified at least one profile to be imported into the job opening.

This example illustrates the Combined Profile Information page

**Combined Profile Information**

Job Posting Title   Accountant

**Profile Combination** ?

Profile ID	Description	Primary Profile	Update Primary Profile
100665	Cluster - Human Service Profes	<input type="checkbox"/>	<input type="checkbox"/>
K0G001	Person - Rebekah Jones	<input type="checkbox"/>	<input type="checkbox"/>

**Competencies** ?

Profile ID	Competencies
K0G001	Ability to prioritize tasks
K0G001	Organize people and goal tasks
K0G001	Resource Planning

**Memberships** ?

Profile ID	Memberships
100665	Registered Nurses Association

**Items Not Loaded** ?

Description
Competencies ( 12 )

[Return to Previous Page](#)
Continue

## Profile Combination

This grid lists the profiles whose attributes you are bringing into the job opening. It lists both person and non-person profiles.

---

**Note:** You cannot change your profile selection on this page. To change your profile selection, return to the Primary Job Opening Information page.

---

<b>Field or Control</b>	<b>Description</b>
<b>Profile ID</b>	Displays the profile ID. When you review specific content items that system copied into the job opening, the profile ID for the content item indicates which profile supplied the data.
<b>Description</b>	Displays the type of profile and the profile name. For example, a person profile description follows the format <i>Person - &lt;Person Name&gt;</i> .
<b>Primary Profile</b>	You must select one of the profiles as the primary profile for the job opening. Any content items that you later add to the job opening are associated with the primary profile, unless there is a profile type configuration incompatibility, in which case the profile ID for the new content item is <i>0</i> .
<b>Update Primary Profile</b>	<p>If the primary profile is a non-person profile, select this check box if you want to update the profile based on the job opening profile. For example, when you are creating a job opening, the hiring manager might provide updated requirements that you can then transfer back to the job opening's primary non-person profile, maintaining consistency and eliminating redundant work efforts. Copying occurs only when the job opening is in an open status.</p> <p>The system updates the profile when you save the job opening after adding new content items or after modifying or removing content items that came from the primary profile.</p> <hr/> <p><b>Note:</b> You cannot update person profiles from the job opening.</p> <hr/>

### Profile Associations

This grid lists the job codes and positions that are associated with the profiles that you are using. If any of the profiles were derived from job code or position data that you entered on the Primary Job Opening Information page, then that job code or position necessarily appears in the grid.



<b>Field or Control</b>	<b>Description</b>
<b>Primary Job Code</b>	<p>Select the primary job code and position for the job opening. The job code and position that you entered on the Primary Job Opening information page are selected by default. If you change this default, the job opening is created using the job code and position that you select here instead of the original job code and position from the Primary Job Opening information page.</p> <hr/> <p><b>Note:</b> Position information appears only under full or partial position management.</p> <hr/>

## Content Types and Content Items

Grids appear for every profile content type that has data to be imported. Each grid lists the specific content items that are to be loaded into the job opening. For example, the Competencies grid lists specific competencies.

---

**Note:** The system imports data only for profile content types that are included in the job opening template.

---

<b>Field or Control</b>	<b>Description</b>
<b>Profile ID</b>	<p>Identifies the profile that provided the content type. For example, if you load Betty Locherty's person profile and the Director of Finance job profile, the Competencies grid lists both Betty's competencies and the job competencies, and this field lets you know which profile a specific competency came from.</p> <p>If multiple profiles have the same item (for example, an identical competency), and one profile has a version with a later effective date, then the system brings that later version and its Profile ID in the grid for that content type.</p>
<b>&lt;content item&gt;</b>	<p>The second column in each grid displays the name of the specific content item that is to be loaded to the job opening. For example, in the Competencies grid, this column shows the name of the competency.</p>

## Items Not Loaded

<b>Field or Control</b>	<b>Description</b>
<b>Description</b>	<p>Displays information about the number and type of profile attributes that cannot be imported into the job opening. For example, <i>Competencies (3)</i> indicates that three competencies were not loaded.</p> <p>Items are not loaded when your organization has configured a particular type of attribute differently for job openings than for the type of profile that you are importing. The message appears so that you understand why attributes that you might have been expecting to see do not appear on this page. You cannot force the system to import the incompatible attributes.</p>

## Job Opening Page

Use the Job Opening page (HRS\_JOB\_OPENING) to create a job opening and to manage job opening details.

Navigation:

- **Recruiting > Create Job Opening**

Click the **Continue** button on the Primary Job Opening page (and, if applicable, on the Combined Profile Information page).

- **Recruiting > Search Job Openings**

Click a job opening to access the Job Opening page, then access the Details tab.

This example illustrates the toolbar, header, and tabs on the Job Opening page.

**Job Opening**

Save and Open Save as Draft | [Recruiting Home](#) | [Notification](#) | [Start Over](#)

<b>Job Opening ID</b> NEW <b>Job Posting Title</b> Management - Staff Assistant <b>Job Code</b> 170030 (Assistant-Management Staff) <b>Position Number</b> 19000005 (Management - Staff Assistant) <b>Primary Recruiting Location</b> 35 (Delaware Operations) <b>Remove Date</b> 31/03/2024	<b>Status</b> 005 Draft <b>Business Unit</b> GBIBU (Global Business Institute BU) <b>Department</b> 13000 (Finance and Administration) <b>Job Family</b> KADMIN (Administrative Support) <b>Post Date</b> 06/03/2024 <b>Next Review Date</b> 20/03/2024
---	--

Job Details
Qualifications
Screening
Job Postings
Hiring Team

**Job Postings** ⓘ







Postings	Primary Posting Title	
Management - Staff Assistant	☑	🗑

Add Job Posting

## Toolbar

**Note:** The toolbar is different when you view the job on the [Manage Job Opening Page](#).

<b>Field or Control</b>	<b>Description</b>
<b>Save and Open</b>	<p>Click this button to save the job opening and set the job opening status to <i>Open</i> (or, if you changed the delivered status configuration, to the default job opening status you defined.)</p> <p>This button appears on unsaved and Draft job openings if no approval is required.</p>
<b>Save and Submit</b>	<p>Click this button to save the job opening and set the job opening status to <i>Pending Approval</i> (or, if you changed the delivered status configuration, to the pending approval status that you defined.) This action also sends a notification to the approver.</p> <p>This button appears on unsaved and Draft job openings if approvals are required.</p>
<b>Save as Draft</b>	<p>Click to save the job opening and set the job opening status to <i>Draft</i>.</p> <p>This button appears on unsaved and Draft job openings regardless of whether approval is required.</p>
<b>Save</b>	<p>Click to save changes to a job opening without changing its status.</p> <p>This button appears replaces the Save as Draft button after job opening is opened or submitted.</p>
<b>Delete</b>	<p>Click to delete the job opening and return to the <a href="#">Primary Job Opening Information Page</a>.</p> <p>This button appears only on Draft job openings.</p>
 <b>Notification</b>	<p>Click to access the <a href="#">Send Notification Page</a>. Notifications that you send this way are simple text messages, without a link to the job opening.</p> <p>This button is visible only in unsaved and draft job openings.</p>

<b>Field or Control</b>	<b>Description</b>
<b>Start Over</b>	<p>Click to return to the <a href="#">Primary Job Opening Information Page</a> to start the job creation process over.</p> <p>This button appears only if you have not yet saved the job opening.</p>
 <b>Print Job Opening</b>	<p>Click to open the <a href="#">Select Job Opening Sections Page</a>, where you generate the Job Opening report after selecting which data to include in the report.</p> <p>This button appears only after you initially save the job opening, either by saving as draft, opening, or submitting.</p>
 <b>Clone</b>	<p>Click to open the <a href="#">Clone Job Opening Page</a> where you can clone the current job opening.</p> <p>This button becomes visible after a job opening is opened or submitted.</p>
 <b>Create New</b>	<p>Click to access the <a href="#">Primary Job Opening Information Page</a>, where you begin the process of creating a new job opening.</p> <p>This button becomes visible after a job opening is opened or submitted.</p>
 <b>Job Opening List</b>	<p>If you access a draft job opening from a list of job openings (such as the search results on the Search Job Openings page), use this toolbar button to return to the job opening list.</p>
 <b>Previous Job Opening</b> ,  <b>Next Job Opening</b>	<p>If you access a job opening from a list of job openings (such as the search results on the Search Job Openings page), use these toolbar buttons to return to the job opening list or to navigate directly to other job openings in the list.</p>

## Header

The read-only fields below the toolbar provide basic information about the job opening.

<b>Field or Control</b>	<b>Description</b>
<b>Job Opening ID</b>	Displays the unique identifier for the job opening.
<b>Status</b>	Displays the current status of the job opening.

<b>Field or Control</b>	<b>Description</b>
<b>Job Posting Title</b>	Displays the primary posting title for the job opening. This is initially entered on the Primary Job Opening Information page. You update the posting title by creating job postings and designating one to be used for the primary posting title. Manage postings and the primary posting title on the <a href="#">Job Opening Page: Job Postings Section</a> .
<b>Business Unit</b>	Displays the business unit of the job opening.
<b>Job Code</b>	Displays the job code of the job opening. If a job opening has multiple job codes, this is the primary job code.  Under full position management, the Job Code field is not shown. The Job Code field is also hidden if the job opening does not specify a job code, This occurs only in Continuous job openings.
<b>Department</b>	Displays the department for the job opening. If the job opening does not specify a department, this field is not visible.
<b>Position</b>	Displays the position for the job opening. If a job opening has multiple positions, this is the primary position. If the job opening does not specify a primary position, this field is not visible.  Job openings include position data only if the PeopleSoft HCM system is configured for full or partial position management.
<b>Job Family, Job Profile ID, Company, or Salary Plan/Grade</b>	If your template segmenting value (the data that controls selection of a job opening's recruitment template) is job family, job profile ID, company, or salary grade, then the corresponding field appears in the job opening header.  The segmenting value is configured on the <a href="#">Recruiting Installation - General Page</a> .
<b>Post Date, Remove Date, and Next Review Date</b>	Displays the posting destination details for the job. These fields appear if the job has a job posting that is made primary. Also, the posting should have a primary posting destination enabled, and the post date, remove date and next review dates should be available for the posting destination. See <a href="#">Posting Information Page</a> .

## Tabs

Job opening details are organized so that they appear under tabs that you define in the job opening template. Therefore, the number and names of tabs can vary across job openings.

If job opening approvals are active, then the [Job Opening Page: Approvals Tab](#) appears after the job is submitted for approval. If only one tab is defined (and there is no Approvals tab), the system hides the single tab.

After the job opening moves into an open status, the tabs from the Job Opening page are rendered as subsection links on the Details tab of the Manage Job Opening page.

## Sections

Job opening data is organized into *sections*. Job opening templates control which sections appear on which job openings.

The following table lists all sections that can appear on the Job Opening page:

<b>Section Name on the Job Opening Page</b>	<b>Section Name in the Job Opening Template</b>	<b>Description</b>
<a href="#">Job Opening Page: Opening Information Section</a>	Job Information	This section includes basic information such as how many openings are to be filled, where the job is located, and where the job fits in your organizational structure.  This section appears in all job openings.
<a href="#">Job Opening Page: Staffing Information Section</a>	Staffing Information	Staffing information includes data about the work schedule, travel percentage, full-time or part-time status, and regular or temporary status.
<a href="#">Job Opening Page: Salary Information Section</a>	Salary Information	Salary information includes data such as the salary plan, salary grade and step ranges, salary range, and pay frequency.
<a href="#">Job Opening Page: Work Experience &amp; Education Section</a>	Education and Experience	Work Experience & Education is a matrix that determines the minimum amount of work experience that is required for applicants with various levels of education
<a href="#">Job Opening Page: &lt;Profile Content Type&gt; Section</a>	<Profile Content Type>	Profile content types enable you to capture attributes such as competencies or degrees that you require for the job. The specific attributes that are available to include in the job opening depend on your system configuration.  See <a href="#">Understanding Profile Integration for Job Openings</a> .
<a href="#">Job Opening Page: Profile Combination Section</a>	Profile Details	The Profile Combination section lists person and non-person profiles whose attributes you imported into the job opening.

<b>Section Name on the Job Opening Page</b>	<b>Section Name in the Job Opening Template</b>	<b>Description</b>
<a href="#">Job Opening Page: Screening Questions Section</a>	Screening Questions	<p>Screening questions are incorporated into the online application seen by applicants who use PeopleSoft Candidate Gateway to apply for the job. All of a job opening's screening questions appear in the online application, regardless of whether you use the questions as screening criteria.</p> <hr/> <p><b>Note:</b> The only way to provide answers to questions is through Candidate Gateway. Recruiters cannot enter answers on behalf of applicants.</p> <hr/>
<a href="#">Job Opening Page: Applicant Screening Section</a>	Screening Options	The Applicant Screening section lists the screening levels for the job opening and enables you to drill into each screening level to define its screening criteria and scoring system.
<a href="#">Job Opening Page: Job Postings Section</a>	Job Postings	Job postings make job opening information available to applicants. Postings include an applicant-facing job posting description that can vary for internal and external postings. Postings are associated with one or more posting destinations.
<p><a href="#">Job Opening Page: Assignments Sections</a>, consisting of the following sections:</p> <ul style="list-style-type: none"> <li>• Recruiters</li> <li>• Hiring Managers</li> <li>• Interviewers</li> <li>• Interested Parties</li> <li>• Screening Team</li> </ul>	<ul style="list-style-type: none"> <li>• Recruiter Assignments</li> <li>• Hiring Manager Assignments</li> <li>• Interviewer Assignments</li> <li>• Interested Party Assignments</li> <li>• Screening Notification Team</li> </ul>	<p>These sections, which all appear in an <b>Assignments</b> group box on the Job Opening page, list the members of the job opening's hiring team.</p> <p>All hiring team members can access both the job opening and the data for any applicant who is associated with the job opening.</p>

If the system is configured to allow multiple job codes in a job opening, then sections with data that can vary by job code appear in an Additional Job Specifications scroll area.

See [Working With Multiple Job Codes in a Job Opening](#) .

## Send Notification Page

Use the Send Notification page (HRS\_JO\_SEND\_EMAIL) to send notifications from the context of a draft job opening.

Navigation:



Click the **Notification** toolbar button on the Job Opening page. This button appears only when the job opening is in Draft status.

This example illustrates the Send Notification page.

### Send Notification

#### Recipient Information

*To	<input type="text"/>	 Find
Cc	<input type="text"/>	 Find
Bcc	<input type="text"/>	 Find

  

#### Sender Information

From HCMGENUser1@mailtest.com

#### Message

*Subject	<input type="text"/>
Message	<div> <input type="text"/></div>



## Entering Basic Job Opening Data

This topic discusses the Opening Information section of the Job Opening page. This section is the only section that must appear in all job openings.

### Pages Used to Enter Basic Job Opening Data

<i>Page Name</i>	<i>Definition Name</i>	<i>Usage</i>
<u>Job Opening Page: Opening Information Section</u>	HRS_JOB_OPENING	Enter basic organizational information about the job opening.
<u>(USF) Candidate Name Requests Page</u>	HRS_JO_NM_SEC	(USF) Enter candidate name requests.

### Job Opening Page: Opening Information Section

Use the Opening Information section on the Job Opening page (HRS\_JOB\_OPENING) to enter basic organizational information about the job opening. This section is required for all job openings.

Navigation:

- **Recruiting > Create Job Opening**

Click the **Continue** button on the Primary Job Opening page (and, if applicable, on the Combined Profile Information page).

- **Recruiting > Search Job Openings**

Click a job opening to access the Job Opening page, then access the Details tab.

This is the first of three examples that illustrate the Job Opening page: Opening Information section.

### Job Opening

Save and Submit
Save as Draft
Notification
Start Over

**Job Opening ID** NEW

**Job Posting Title** Senior Manager-Finance

**Department** 13000 (Finance and Administration)

**Status** 005 Draft

**Business Unit** GBIBU (Global Business Institute BU)

**Job Family** KFIN (Finance)

Job Details
Qualifications
Screening
Job Postings
Hiring Team

**Opening Information** ?

**\*Template ID**  Requisition Default

**Job Opening Type** Standard Requisition

**Created By** KU0007 Betty Locherty

**Created**  BT

**\*Openings to Fill**

**Target Openings**

**Available Openings**

**Establishment ID**

**Business Unit**  Global Business Institute BU

**Company**  Global Business Institute

**Department**  Finance and Administration

**Status Code** 005 Draft

**Status Reason**

**\*Status Date**  BT

This is the second of three examples that illustrate the Job Opening page: Opening Information section.

**Desired Start Date**

**Encumbrance Date**

**Projected Fill Date**

**Date Authorized**

**Referral Program ID**

**\*Recruitment Type**

**\*Area of Consideration**

**Recruitment Contact**

**Draft Status**

**Country**  United States

**Citizenship Status**

**Minimum Age**

**Maximum Age**

**Gender**

Candidate Name Requests

**Locations** ?

*Location	Location Description	Primary Location	
<input type="text"/>		<input type="checkbox"/>	

Add Location

**Recruiting Locations** ?

*Recruiting Area	Recruitment Area Description	Primary Recruiting Area	Target Openings	
<input type="text" value="37"/>	Corporation Headquarters	<input checked="" type="checkbox"/>	<input type="text" value="1"/>	

Add Recruiting Location

This is the third of three examples that illustrate the Job Opening page: Opening Information section.

The screenshot shows the 'Opening Information' section of a job opening page. It consists of four main sections, each with a search field and an 'Add' button:

- Priority Placement Considerations:** Features a search field for '\*Program' and an 'Add Priority Placement Program' button.
- Positions:** Features a search field for '\*Position', a 'Position Number' field, and a 'Primary Position' checkbox. It includes an 'Add Position' button.
- Employees Being Replaced:** Features a search field for '\*Employee ID' and a 'Name' field. It includes an 'Add Employee' button.
- Works Council Information:** Features a search field for 'Works Council ID'.

## Understanding Field Visibility

Certain fields in these sections appear only in U.S. federal installations.

Other fields may be hidden from users with specific roles based on the applicable flexible job creation process. The system identifies the applicable flexible job creation process based on the recruitment template and based on data in certain “driver fields”: business unit, job family, job code, department, and primary recruiting location. Modifying the recruitment template or any of the driver fields does not immediately change the flexible job creation process. Instead, the system applies any new flexible job creation process the next time you access the job opening.

It is possible for users to enter data in fields that are later hidden because of a change in the flexible job creation process. However, as soon as the job goes into Pending or Open status, all users can see all fields.

## Opening Information

<b>Field or Control</b>	<b>Description</b>
<b>Template ID</b>	<p>Select a recruitment template to associate with the job opening.</p> <p>The system determines the default value for this field based on the <b>Template Segmenting Type</b> entered on the <a href="#">Recruiting Installation - General Page</a>, the <b>Segmentation Values</b> entered on the <a href="#">Segmentation Values Page</a>, and the job opening data that you enter.</p> <p>This field is visible only to users with administrator privileges.</p>
<b>Job Opening Type</b>	<p>Displays the type of job opening selected on the Primary Job Opening Information page: <i>Standard Requisition</i> or <i>Continuous Job Opening</i>.</p>

<b>Field or Control</b>	<b>Description</b>
<b>Created By</b>	The default creator is the person who originally created the job opening, but you can modify this if necessary.
<b>Created</b>	The default date is the date that the job opening was actually created, but you can modify this if necessary.
<b>Openings to Fill</b>	<p>Specify whether the openings are:</p> <ul style="list-style-type: none"> <li>• <i>Limited</i>: Enables the <b>Target Openings</b> and <b>Available Openings</b> fields to appear. The system closes the job opening when all openings are filled.</li> <li>• <i>Unlimited</i>: Hides the <b>Target Openings</b> and <b>Available Openings</b> fields. The job opening stays open until it is manually closed.</li> </ul>
<b>Target Openings</b>	<p>Enter the number of positions that are to be filled. This field appears only if you select <i>Limited</i> in the <b>Openings to Fill</b> field.</p> <p>Farther down the page, in the Recruiting Locations grid, you will specify the number of target openings associated with specific recruiting locations. The overall number of target openings must be equal to or greater than the total target openings for all recruiting locations.</p>
<b>Available Openings</b>	<p>This field displays the number of available openings only if <i>Limited</i> was selected in the <b>Openings to Fill</b> field. The initial number of openings is the value entered in the <b>Target Openings</b> field. When you hire an applicant in this job opening, the system decreases this number by one. When all available positions are filled, the status of the job opening is set to <i>Closed</i>.</p> <p>The total <i>Available Openings</i> is always less than or equal to the <i>Target Openings</i>.</p>
<b>Establishment ID</b>	<p>Select the Establishment ID for this job opening.</p> <p>The value defaults to the establishment ID assigned to the job code or position ID.</p>

<b>Field or Control</b>	<b>Description</b>
<b>Business Unit</b>	<p>Select a business unit. The default value is the value that you entered on the Primary Job Opening Information page.</p> <p>Changing the business unit can result in a new flexible job creation process being used the next time the job opening is accessed.</p>
<b>Position Number</b>	<p>If the system is configured to allow multiple jobs or positions in a job opening, this field does not appear. Instead, a Positions grid appears further down on the page.</p> <p>If the system allows only one position in the job opening, use this field to identify a position number. This field defaults to the value, if any, entered on the Primary Job Opening Information page.</p> <p>When you enter a position, the system brings position data (such as job code, company, department, location, and regulatory region) into the job opening. You can override this data within the job opening, but any overrides that you enter are not brought into the job data record that is created during the hire process. This is because the job data record gets its default data from the position rather than from the job opening.</p> <p>Changing the position can result in a new flexible job creation process being used the next time the job opening is accessed.</p>
<b>Company</b>	<p>Select a company. The default value is the value, if any, that you entered on the Primary Job Opening Information page.</p>
<b>Job Code</b>	<p>If the system is configured to allow multiple jobs or positions in a job opening, this field does not appear. Instead, a job code scroll area appears for those job opening sections where each job code has its own settings.</p> <p>If the system allows only one job code in the job opening, use this field to identify the job code. The default value is the value, if any, that you entered on the Primary Job Opening Information page.</p> <p>Changing the job code can result in a new flexible job creation process being used the next time the job opening is accessed.</p>

<b>Field or Control</b>	<b>Description</b>
<b>Department</b>	<p>Select a department. The default value is the value, if any, that you entered on the Primary Job Opening Information page. Changing the department can result in a new flexible job creation process being used the next time the job opening is accessed.</p> <p>Users who have access to the job opening's department through the HCM department security tree also have access to the job opening, even if they are not part of the hiring team.</p>
<b>Status Code</b>	<p>Displays the current job opening status. In general, the system sets the value of this field as the job opening moves through the recruiting process and, if approvals are active, through the approval process.</p> <p>Recruiting administrators are the only users who can make direct edits to the job opening status. For all other users, the field is read-only. If approvals are required, this field is also read-only for recruiting administrators until the job is approved.</p> <p>Non-administrators can update the status indirectly from the Search Job Openings page, where the Group Action menu provides actions that let users close a job opening, cancel it, or put it on hold.</p>
<b>Status Reason</b>	<p>Select a status reason that is associated with the current status.</p> <p>When the Status Code for a job opening changes, the system clears the Status Reason.</p>
<b>Status Date</b>	<p>Enter the date on which the status went into effect. When the system makes status changes, it also updates the status date.</p>
<b>Desired Start Date</b>	<p>Enter the date that you would like a successful applicant to start work.</p> <p>This field can be used as a parameter for screening applicants.</p>

<b>Field or Control</b>	<b>Description</b>
<b>Encumbrance Date</b>	<p>If your organization uses the Commitment Accounting business process in PeopleSoft Human Resources, indicate how the system budgets for the unfilled position. Select one of these options:</p> <ul style="list-style-type: none"> <li>• <i>Authorization Date</i>: Start budgeting for the position from the date that it is authorized, as indicated in the <b>Date Authorized</b> field.</li> <li>• <i>Project Fill Date</i>: Start budgeting for the position from the date that you expect to fill the position as indicated in <b>Projected Fill Date</b> field.</li> </ul> <p>If you're not using commitment accounting, leave this field blank.</p>
<b>Projected Fill Date</b>	<p>If you selected <i>Project Fill Date</i> in the <b>Encumbrance Date Indicator</b> field, enter the date that you expect to fill the job opening.</p>
<b>Date Authorized</b>	<p>The date that the job opening changed to an Open status. If approvals are being used, this date is the date the job opening reaches final approval.</p> <p>When you create a job posting, you can set the posting date relative to this date.</p>
<b>Referral Program ID</b>	<p>Select an employee referral program. The default value is the employee referral program associated with the recruitment template, if any.</p>
<b>(USF) Recruitment Type</b>	<p>Select from the following values:</p> <ul style="list-style-type: none"> <li>• <i>Internal</i> - only current federal employees.</li> <li>• <i>Merit Promotion</i> - current and previous federal employees.</li> <li>• <i>Open Competition</i> - internal and external applicants.</li> </ul> <p>The system uses the recruitment type to determine what type of priority to give to applicants with priority placement codes.</p> <p>See <a href="#">Understanding Priority Placement Processing</a>.</p>

<b>Field or Control</b>	<b>Description</b>
<b>(USF) Area of Consideration</b>	<p>Select from the following values:</p> <ul style="list-style-type: none"> <li>• <i>Agency</i></li> <li>• <i>External Government</i></li> <li>• <i>Federal Government</i></li> <li>• <i>Nationwide</i></li> <li>• <i>Subagency</i></li> <li>• <i>Worldwide</i></li> </ul>
<b>Recruitment Contact</b>	<p>Select a recruitment contact. Recruitment contacts are defined on the Recruitment Contacts page and must have a recruitment type of <i>Office</i>.</p>

**(USF) Additional U.S. Federal Page Elements**

<b>Field or Control</b>	<b>Description</b>
<b>(USF) Draft Status</b>	<p>Select the applicant's draft status:</p> <ul style="list-style-type: none"> <li>• <i>Not Applicable</i></li> <li>• <i>Not Yet Registered</i></li> <li>• <i>Registered</i></li> </ul>
<b>(USF) Country</b>	<p>Select the country in which the job opening is to be filled.</p>
<b>(USF) Citizenship Status</b>	<p>Select the applicant citizenship status.</p> <p>This field can be used as a parameter for screening applicants.</p>
<b>(USF) Minimum Age</b>	<p>Enter the minimum age for this job opening.</p> <p>This field can be used as a parameter for screening applicants.</p>
<b>(USF) Maximum Age</b>	<p>Enter the maximum age for this job opening.</p> <p>This field can be used as a parameter for screening applicants.</p>



<b>Field or Control</b>	<b>Description</b>
<b>(USF) Gender</b>	Enter any gender restriction for this job opening.  This field can be used as a parameter for screening applicants.
<b>(USF) Candidate Name Requests</b>	Click to access the Candidate Name Requests page, where you can enter candidates that you are requesting for the job opening. This information can be used in resolving ties when screening applicants.

## Locations

Locations represent your organization’s physical locations. These are system-wide values, not specific to recruiting.

See “Establishing Locations” (Application Fundamentals).

<b>Field or Control</b>	<b>Description</b>
<b>Location</b>	Select a location code for the physical location of this job opening.  If the location you select is associated with any recruiting locations (on the <a href="#">Recruiting Locations Page</a> ), those recruiting locations are added to the Recruiting Locations grid. Deleting a location does not, however, remove associated recruiting locations from the job opening.
<b>Primary Location</b>	If there is more than one location associated with the job opening, indicate which location is primary.
<b>Add Location</b>	Click to add another row to the Locations grid.

## Recruiting Locations

Recruiting Locations are the locations that are visible to applicants in Candidate Gateway. For example, the physical location might be a specific city, while the recruiting location shown to applicants and used for Candidate Gateway job searches might be a broader area or region.

See [Setting Up Recruiting Locations](#).

<b>Field or Control</b>	<b>Description</b>
<b>Recruiting Area</b>	<p>Select a recruiting location for the job opening.</p> <p>When you set up recruiting locations, you associate them with physical locations. However, adding a recruiting location to a job opening does not cause the related recruiting locations to be added to the job opening.</p> <hr/> <p><b>Note:</b> In Candidate Gateway, the recruiting location and its associated physical location control whether an applicant is asked to provide USA-specific self-identification details (gender and ethnicity) during the application process. The physical locations that are explicitly listed on the job opening are <i>not</i> used for this purpose.</p> <hr/>
<b>Primary Recruiting Area</b>	<p>If there is more than one recruiting location associated with the job opening, indicate which recruiting location is primary.</p> <p>Changing the primary recruiting location can result in a new flexible job creation process being used the next time the job opening is accessed.</p>
<b>Target Openings</b>	<p>Enter the number of target openings for each recruiting location. The total number of target openings for all recruiting locations cannot exceed the overall number of target openings for the job opening.</p>
<b>Add Recruiting Location</b>	<p>Click to add another row to the Recruiting Locations grid.</p>

### (USF) Priority Placement Considerations

<b>Field or Control</b>	<b>Description</b>
<b>Program</b>	<p>Select a priority placement program to associate with this job opening.</p> <p>The Priority Placement process uses this information, along with salary grade and level for the job opening, to identify any applicants that have an entitlement to priority placement consideration.</p>
<b>Add Priority Placement Programs</b>	<p>Click to add another row to the <b>Priority Placement Considerations</b> grid.</p>

## Positions

This grid appears only if the [Recruiting Installation – Jobs Page](#) is configured to allow multiple jobs or positions in a job opening. If this grid appears, there is no Position Number field in the Opening Information group box.

<i>Field or Control</i>	<i>Description</i>
<b>Position</b>	Select a position that is associated with this job opening.
<b>Primary Position</b>	<p>Select this check box to identify the primary position when there are multiple job positions associated with a job opening.</p> <p>On the <a href="#">Search Job Openings Page</a>, if users search by position number, only the primary position is searchable.</p> <p>The system brings data from the primary position into the job opening, including job code, company, department, location, and regulatory region. You can override this data within the job opening, but any overrides that you enter are not brought into the job data record that is created during the hire process. This is because the job data record gets its default data from the position rather than from the job opening.</p> <p>Changing the primary position can result in a new flexible job creation process being used the next time the job opening is accessed.</p>

## Employees Being Replaced

<i>Field or Control</i>	<i>Description</i>
<b>Employee ID</b>	If specific employees are being replaced, enter the employee IDs here.
<b>Add Employee</b>	Click to add another row to the <b>Employees Being Replaced</b> grid.

## Works Council Information

Use this group box to select a works council ID. This group box appears only if the Works Council Information section is included on the associated job opening template.

<i>Field or Control</i>	<i>Description</i>
<b>Works Council ID</b>	Select a works council ID. Only works council IDs with the same setID as the user appear as values.  See “Setting Up Works Councils” (PeopleSoft Human Resources Manage Labor Administration).

## (USF) Candidate Name Requests Page

Use the Candidate Name Requests page (HRS\_JO\_NM\_SEC) to enter candidate name requests in US Federal implementations.

Navigation:

Click the **Candidate Name Request** link in the Opening Information section of the Job Opening page.

This example illustrates the Candidate Name Requests page.

<i>Field or Control</i>	<i>Description</i>
<b>Name</b>	Enter the name of a person who you would like to target for this position. This field can be used as a tie breaker in screening.

---

## Working With Multiple Job Codes in a Job Opening

Job openings can have multiple job codes if you use the [Recruiting Installation – Jobs Page](#) to enable this capability.

This topic provides an overview of copying qualifications to non-primary job codes and discusses how to:

- Add additional job codes to a job opening.
- Copy job qualifications to non-primary job codes.

## Understanding Data That Can Vary By Job Code

If a job opening has multiple job codes, an **Additional Job Specifications** scroll area contains the sections where the data can vary by job code, including:

- [Job Opening Page: Staffing Information Section](#)
- [Job Opening Page: Salary Information Section](#)
- [Job Opening Page: Work Experience & Education Section](#)
- [Job Opening Page: <Profile Content Type> Section](#)
- [Job Opening Page: Screening Questions Section](#)
- [Job Opening Page: Applicant Screening Section](#)

Data in the following sections does not vary by job code:

- [Job Opening Page: Opening Information Section](#)
- [Job Opening Page: Profile Combination Section](#)
- [Job Opening Page: Job Postings Section](#)
- [Job Opening Page: Assignments Sections](#) (recruiters, hiring managers, interviewers, interested parties, and screening team)

## Understanding Copying Qualifications To Non-Primary Job Codes

To expedite data entry in job openings with multiple job codes, the system enables you to copy job qualifications from the primary job code to all other job codes.

### The Copy Process

Copy functionality is available for both standard requisitions and continuous job openings.

The copy process copies data to existing non-primary job codes. Any data that already exists for the non-primary job codes is not affected.

For example, if the primary job code includes competencies A, B, and C, and a non-primary job code includes competency X, then after the copy process, the non-primary job code will have four competencies: A, B, C, and X.

If you add additional job codes after copying, the system automatically copies the primary job code qualifications to the newly added job code. In this situation, the system copies the primary job code qualifications as they are at the time the new job code is created, which may be different than the qualifications that were copied at the time of the original copying process.

### Copyable Data

The data that is copied includes:

- Work Experience and Education.

- Screening Questions.

The copy process copies the evaluators for open-ended questions along with the questions themselves.

- Content items from profile-based qualifications.

Examples of profile-based qualifications include competencies, degrees, and languages.

---

**Note:** There are other data sections (staffing information, salary information, and screening information) that have separate rows for each job code in the job opening, but the copy process does *not* copy data in these sections. The Copy Qualifications from Primary Job Code button does not appear unless the page shows copyable sections.

---

## Adding Additional Job Codes to a Job Opening

Access the [Job Opening Page](#).

If **Allow Multiple Jobs/Positions** is selected on the [Recruiting Installation – Jobs Page](#), the **Additional Job Specifications** scroll area appears around sections where the job data can vary by job code.

This example illustrates the Additional Job Specifications scroll area for managing multiple job codes.

These additional page elements appear when multiple job or positions are enabled.

<b>Field or Control</b>	<b>Description</b>
<b>Job Code</b>	<p>When you first create a job opening, the job code (if any) that you entered on the Primary Job Opening Information page appears in this field by default. As you create additional rows for additional job codes, use this field to enter the job codes.</p> <p>Candidate Gateway job postings show only the primary job code; applicants cannot tell that there are additional job codes in the job opening.</p>

<b>Field or Control</b>	<b>Description</b>
<b>Primary Job Code</b>	<p>Select this check box to identify the primary job code when there are multiple job codes associated with a job opening.</p> <p>Changing the primary job code can result in a new flexible job creation process being used the next time the job opening is accessed.</p> <p>If profile integration is active, change the value of the primary job code displays a dialog that gives you a choice whether to retain profile data that is associated with the original job code replace the original profile data with content from the new job code. The system does not, however, import profile data for non-primary job codes.</p>
<b>Add Job Codes</b>	<p>Click to add another job code to the job opening.</p> <p>This button appears at the bottom of every page where the Additional Job Specifications scroll area appears.</p>
<b>Delete Job Code</b>	<p>Click to delete a job code from the job opening.</p> <p>This button appears at the bottom of every page where the Additional Job Specifications scroll area appears.</p>

## Copying Job Qualifications to Non-Primary Job Codes

Access the [Job Opening Page](#).

Access a section that includes copyable qualifications.

This example illustrates that the Copy Qualifications from Primary Job Code button appears on pages where there are copyable sections.

The screenshot displays a user interface for configuring job opening qualifications. It features three main sections:

- Tests or Examinations:** A table with columns for Profile ID, Tests or Examinations, and an Action column with a trash icon. It lists two entries: 'Accounting Aptitude Test' (Profile ID 100886) and 'Business Mathematics' (Profile ID KU0007). Below the table is an 'Add Tests or Examinations' button.
- Screening Questions:** A table with columns for \*Question, Question Order, and Action. It shows one entry: 'Overtime' with a 'View Answers' button and a trash icon. Below the table are 'Add Screening Question' and 'Load from Question Set' buttons.
- Buttons:** At the bottom of the configuration area, there are four buttons: 'Add Job Code', 'Delete Job Code', and 'Copy Qualifications from Primary Job Code'.

<i>Field or Control</i>	<i>Description</i>
<b>Copy Qualifications from Primary Job Code</b>	<p>Click this button to copy job opening qualifications from the primary job code to all other job codes. Copied information includes work experience and education, screening questions, and any profile-based qualifications.</p> <p>The copied information is added to any existing data in the other job codes; it does not overwrite or delete anything.</p> <p>This button appears only on page sections that include copyable data. If there is only one job code in the job opening, the button is visible but not active.</p>

## Adding Staffing and Salary Information

This topic discusses the Staffing Information and Salary Information sections on the Job Opening page.

### Page Used to Add Salary and Staffing Information

<i>Page Name</i>	<i>Definition Name</i>	<i>Usage</i>
<u>Job Opening Page: Staffing Information Section</u>	HRS_JOB_OPENING	Enter staffing information for a job opening, including data about the work schedule, travel percentage, full-time or part-time status, and regular or temporary status.
<u>Job Opening Page: Salary Information Section</u>	HRS_JOB_OPENING	Enter salary information for a job opening, including data such as the salary plan, salary grade and step ranges, salary range, and pay frequency.

### Job Opening Page: Staffing Information Section

Use the Staffing Information section on the Job Opening page (HRS\_JOB\_OPENING) to enter work schedules and other staffing information for the job opening.

**Note:** The template for the job opening controls whether this section appears and, if so, where it appears.

Navigation:

- **Recruiting > Create Job Opening**

Click the **Continue** button on the Primary Job Opening page and, if necessary, on the Combined Profile Information page.

- **Recruiting > Search Job Openings**



Click the link for a job opening in the search results, then click the Job Details tab, then click the link for the type of job opening data you want to access.

This example illustrates the Job Opening page: Staffing Information section.

The screenshot shows a 'Staffing Information' section with the following fields and values:

- Region: USA
- Schedule Type: [Dropdown]
- Regular/Temporary: [Dropdown]
- Not To Exceed Date: [Text]
- Not-to-Exceed Days: [Text]
- Summer Appointment: [Dropdown]
- Shift: [Dropdown]
- Hours: 40.00
- Work Period: Weekly
- Travel Percentage: Never or rarely
- Supervisor Level: [Dropdown]
- FLSA Status: [Dropdown]
- LEO/Fire Position: [Dropdown]
- Sensitivity Code: [Dropdown]
- Type of Appointment: [Dropdown]

### Staffing Information

<b>Field or Control</b>	<b>Description</b>
<b>Region</b>	Select the region in which the job opening is located. Regions are defined on the “Regulatory Region Page” (Application Fundamentals).
<b>Schedule Type</b>	Select whether this a <i>Full-time</i> or <i>Part-Time</i> position.  This field can be used as a parameter for screening applicants.
<b>Regular/Temporary</b>	Select whether this is a <i>Regular</i> or <i>Temporary</i> position.  This field can be used as a parameter for screening applicants.
<b>Begin Date</b>	Enter the date on which the job is to begin.
<b>End Date</b>	Enter the date on which the job is scheduled to end. This field is for temporary job openings.
<b>(USF) Not To Exceed Date</b>	If this is a temporary position, enter the date on which it will end.
<b>(USF) Not To Exceed Days</b>	If this is a temporary position, enter the maximum number of days after the <b>Not To Exceed Date</b> by which the job can extend.

<b>Field or Control</b>	<b>Description</b>
<b>(USF) Summer Appointment</b>	Select this check box if this position is a summer appointment. This information is sent as part of the vacancy information for the USA Jobs program. When there are multiple job codes, the primary job code value for summer appointment is used.
<b>Shift</b>	Select the shift for this job opening.  This field can be used as a parameter for screening applicants.
<b>Hours</b>	Enter the default number of hours in a normal workweek for this job. The field defaults to the number associated with the job code.  This field can be used as a parameter for screening applicants.
<b>Work Period</b>	Select the time period in which employees must complete the standard hours. These values are created by using the Frequency table.
<b>Travel Percentage</b>	Enter the percent of travel required by this job.  This field can be used as a parameter for screening applicants. Applicants meet the screening requirement if they indicate a willingness to travel at least as much as required.
<b>(USF) Supervisor Level</b>	Enter the supervisor level. The default value is the level assigned on the job code.
<b>(USF) FLSA Status</b> (fair labor standards act status)	Select the FLSA status for the job code.
<b>(USF) LEO/Fire Position</b> (law enforcement officer/fire position)	Select the LEO/Fire position code associated with the job code.
<b>(USF) Sensitivity Code</b>	Select a sensitivity code. The default value is the value assigned to the job code.
<b>(USF) Type of Appointment</b>	Select the type of administrative post.

## Job Opening Page: Salary Information Section

Use the Salary Information section on the Job Opening page (HRS\_JOB\_OPENING) to enter salary-related information for the job opening.

**Note:** The template for the job opening controls whether this section appears and, if so, where it appears.

Navigation:

- **Recruiting > Create Job Opening**

Click the **Continue** button on the Primary Job Opening page and, if necessary, on the Combined Profile Information page.

- **Recruiting > Search Job Openings**

Click the link for a job opening in the search results, then click the Job Details tab, then click the link for the type of job opening data you want to access.

This example illustrates the Job Opening page: Salary Information section.

## Salary Information

<b>Field or Control</b>	<b>Description</b>
<b>Salary Admin Plan</b>	Displays the salary plan associated with the position. You can change the salary plan by selecting another from the list of available options.
<b>(USF) Pay Plan</b>	Displays the pay plan associated with the position. You can change the pay plan by selecting another from the list of available options.
<b>From Grade</b>	The pay grade for the job opening, or, if there is a range of pay grades, the low end of the range. The default value is the pay grade that is associated with the position.
<b>From Step</b>	The step for the job opening, or, if there is a range of steps, the low end of the range. The default value is the step that is associated with the position.

<b>Field or Control</b>	<b>Description</b>
<b>To Grade</b>	If the job opening has a range of pay grades, enter the high grade.
<b>To Step</b>	If the job opening has a range of steps, enter the high step.
<b>Salary Range From</b>	The system supplies the salary range from the Job Code table. You can override these values.
<b>Salary Range To</b>	The system supplies the salary range from the Job Code table. You can override these values.
<b>Pay Frequency</b>	Select the pay frequency in which this job is paid.
<b>Currency</b>	Select the currency in which this job is paid.
<b>(USF) Occupational Series</b>	Displays the occupational series that is associated with this occupational series for this position.
<b>(USF) PATCOB Code</b> (Professional, Administrative, Technical, Clerical, Other, Blue Collar code)	<p>Displays the PATCOB code that is associated with occupational series for this position. These codes are occupational categories established by the U.S. Equal Employment Opportunity Commission.</p> <p>PATCOB Code is not a search field for job openings. If you want applicants to be able to search for job openings based on the PATCOB code, you can set up your job families (which are searchable in PeopleSoft Candidate Gateway) to match the PATCOB codes.</p>

## Adding Job Qualifications

This topic discusses the qualification-related sections on the Job Opening page. This includes the Work Experience & Education section as well as all profile-related sections.

## Pages Used to Define Job Qualifications

<i>Page Name</i>	<i>Definition Name</i>	<i>Usage</i>
<u>Job Opening Page: Work Experience &amp; Education Section</u>	HRS_JOB_OPENING	Enter the minimum amount of work experience that is required for applicants with various levels of education  Enter job opening data, including job qualifications such as education and experience, screening questions, and qualifications that have been configured as profile content types.
<u>Job Opening Page: Profile Combination Section</u>	HRS_JOB_OPENING	Review person and non-person profiles whose attributes you imported into the job opening.
<u>Job Opening Page: &lt;Profile Content Type&gt; Section</u>	HRS_JOB_OPENING	Define attributes such as competencies or degrees that you require for the job. The specific types of attributes that are available to include in the job opening depend on your system configuration.
<u>&lt;Profile Content Type&gt; Page</u>	HRS_PROF_DETAIL	Enter detailed information about a specific attribute that is being used as a job qualification.

### Job Opening Page: Work Experience & Education Section

Use the Work Experience & Education section on the Job Opening page (HRS\_JOB\_OPENING) to specify the work requirements for applicants with varying levels of education.

---

**Note:** The template for the job opening controls whether this section appears and, if so, where it appears.

---

Navigation:

- **Recruiting > Create Job Opening**

Click the **Continue** button on the Primary Job Opening page and, if necessary, on the Combined Profile Information page.

- **Recruiting > Search Job Openings**

Click the link for a job opening in the search results, then click the Job Details tab, then click the link for the type of job opening data you want to access.

This example illustrates the Job Opening page: Work Experience & Education section.

*Highest Education Level	Years of Work Experience	
G-Bachelor's Level Degree	7.0	🗑️
I-Master's Level Degree	5.0	🗑️

Add Work Experience and Education

## Work Experience & Education

Use this grid to set up a matrix showing how many years of experience are required for applicants with different education levels.

<b>Field or Control</b>	<b>Description</b>
<b>Highest Education Level</b>	<p>Select an education level so that you can then enter the amount of experience required by applicants who have selected the same value as their highest level of education.</p> <p>Education levels are defined on the Education Level Achieved Table page.</p> <hr/> <p><b>Note:</b> When you use Education &amp; Experience requirements as screening criteria, applicants with a higher education level than the one you selected are <i>not</i> considered to have met the requirement. To prevent the system from penalizing applicants with more education than you require, create additional rows for every degree above the minimum requirement.</p>
<b>Years of Work Experience</b>	<p>Enter the years of work experience required for applicants with the specified level of education. Leave this field blank to indicate that there are no experience requirements for applicants who have attained the given education level.</p> <hr/> <p><b>Note:</b> When the screening process evaluates whether an applicant meets particular education &amp; experience requirements, it fails applications where there are no work experience entries with start dates, even if there are zero years of work experience required.</p>
<b>Add Work Experience and Education</b>	<p>Click to add another row to the <b>Work Experience &amp; Education</b> grid.</p>

## Job Opening Page: Profile Combination Section

Use the Profile Combination section on the Job Opening page (HRS\_JOB\_OPENING) to review the profiles from which job qualifications were imported.

**Note:** The template for the job opening controls whether this section appears and, if so, where it appears. This section is only available for inclusion in the job opening template if the system is configured for profile integration.

Navigation:

- **Recruiting > Create Job Opening**

Click the **Continue** button on the Primary Job Opening page and, if necessary, on the Combined Profile Information page.

- **Recruiting > Search Job Openings**

Click the link for a job opening in the search results, then click the Job Details tab, then click the link for the type of job opening data you want to access.

This example illustrates the Job Opening page: Profile Combination Section.

*Profile Type	Profile ID	Description	Primary Profile	Update Primary Profile
Person Profiles	KU0007	Betty Locherty	<input type="checkbox"/>	<input type="checkbox"/>
Job Profiles	100886	Analyst - Financial	<input checked="" type="checkbox"/>	<input type="checkbox"/>

Add a Profile

This section displays the same Profile Combination grid that appears on the [Combined Profile Information Page](#). The grid lists the profiles whose content items were copied into the job opening. However, here on the Job Opening page, you can add and remove profiles from the grid. If you remove a profile, the system removes all items related to that Profile ID from the job opening. If you add an additional profile, the system copies the additional items from that profile into the job opening.

**Note:** Approvers cannot modify the data in the Profile Combination grid. They can, however, change, add, or delete the individual content items that appear in profile-related grids.

The Description column includes a link that you click to access the profile details; the link is disabled for person profiles when you do not have security access to view that person's profile.

## Job Opening Page: <Profile Content Type> Section

Use the profile-related sections on the Job Opening page (HRS\_JOB\_OPENING) to specify job requirements based on profile content types (for example, competencies, degrees, languages, and so forth).

**Note:** The template for the job opening controls which profile-based section appear on the Job Opening page and where they appear.

Navigation:

- **Recruiting > Create Job Opening**

Click the **Continue** button on the Primary Job Opening page and, if necessary, on the Combined Profile Information page.

- **Recruiting > Search Job Openings**

Click the link for a job opening in the search results, then click the Job Details tab, then click the link for the type of job opening data you want to access.

This example illustrates two profile-related sections of a job opening.

▼ Competencies ?					
Profile ID	Competencies	*Effective Date	Evaluation Type	Proficiency	
KU0007	Takes initiative & follows up	02/02/2009	Self	4-Very Good	
KU0007	Resource Planning	02/02/2009	Self	4-Very Good	
KU0007	Provides Direction	02/07/2000	Self	3-Good	
KU0007	Managerial Efficiency	02/07/2000	Self	4-Very Good	
KU0007	Develop & implement solutions	02/07/2000	Self	3-Good	
100886	PS General Ledger	01/31/2008		3-Good	
100886	PS nVision Reporting	01/31/2008		3-Good	
100886	PS Query	01/31/2009		3-Good	
KU0007	Financial Analysis	02/07/2000	Self	4-Very Good	
KU0007	Financial Planning	02/07/2000	Self	3-Good	
KU0007	Forecasting	02/07/2000	Self	2-Fair	
100886	Budgeting	01/31/2009		3-Good	

Add Competencies

▼ Degrees ?		
Profile ID	Degrees	
100886	Bachelor of Science	
KU0007	Master of Business Admin	

Add Degrees

### <Profile Content Type>

The Job Opening page includes a separate grid for each profile content type in the associated job opening template.

The columns in each grid depend on the settings on the Content Section Configuration – <Content Type> Page.



<b>Field or Control</b>	<b>Description</b>
<b>Profile ID</b>	<p>Identifies the profile from which the content type was imported. For person profiles, this field is blank if you do not have security access to see the person's profile data.</p> <p>If multiple imported profiles have the same item (for example, an identical competency), and one profile has a version with a later effective date, then the system brings that later version and its Profile ID in the grid for that content type. If multiple profiles use the version with the latest effective date, the system populates the Profile ID field with the ID of one of the profiles, though not necessarily the primary profile for the job opening.</p> <p>Any content items that you manually add to the job opening are associated with the primary profile, unless there is a profile type configuration incompatibility, in which case the profile ID for the new content item is 0.</p>
<Content Item Name>	<p>Displays the name of the specific content item. For example, in the Competencies grid, this column (labeled <i>Competencies</i>) displays names of specific competencies such as <i>Forecasting</i> or <i>Budgeting</i>.</p> <p>To modify information about a content item that you have already added to the grid, click the content item name to access the corresponding detail page.</p>
<Additional Column Names>	<p>The columns that appear in each grid depend on the settings in the Content Section Configuration page for the content type. Specifically, fields for which you select the <b>Summary</b> check box on the Content Section Configuration page appear as grid columns.</p>
<b>Add &lt;Content Item&gt;</b>	<p>Click this link to access the content item detail page, where you enter specific content items (such as <i>Analytical Thinking</i>). The fields on the detail page depend on the content type definition within the Manage Profiles business process.</p> <p>Save the data on the detail page to add the content item to the grid.</p>

## Proficiency Ratings

When content types such as competencies are associated with ratings scales, the content type grid displays a proficiency rating. This data is informational only.

When you screen applicants based on competency ratings, the system does not evaluate whether the employee has received the specified rating. Instead, the screening process awards points based on the rating scale that you set up when you define your screening criteria.

## <Profile Content Type> Page

Use the Add <Profile Content Type> page or Update <Profile Content Type> page (HRS\_PROF\_DETAIL) to enter detailed information about a profile content item that is being used as a job qualification.

Navigation:

- Click the Add <profile content type> link that is associated with a profile-related grid in a job opening.
- Click an existing profile content item in a profile-related grid.

This example illustrates the Add <Profile Content Type> page. In this example, the page is used to add competency data, so the page title is Add Competencies. The same fields appear when you access an existing competency, but the page title changes to Update Competencies.

The screenshot shows a web form titled "Add Competencies". It contains several input fields:
 

- \*Effective Date: 12/09/2012
- \*Competency: (empty text box with a search icon)
- \*Evaluation Type: (dropdown menu)
- \*Rating Model: PSCM (with a search icon and the text "Competency Management Scale" next to it)
- \*Proficiency: (dropdown menu)

 At the bottom of the form, there are three buttons: "Save", "Save and Add Another", and "Cancel".

**Note:** The page name and the fields on the page vary depending on the content type.

<b>Field or Control</b>	<b>Description</b>
<b>Save</b>	Click to save changes and return to the Job Opening page.
<b>Save and Add Another</b>	<p>This button appears only when you are adding a new content item. Click the button to save changes and display the page in a fresh state so you can add an additional content item.</p> <p>Although the job opening page is visible behind the Add &lt;Profile Content Type&gt; page, it does not refresh until you close the Add &lt;Content Type&gt; page. Therefore, content items that you save using this button do not immediately appear in the job opening.</p>
<b>Cancel</b>	Click to return to the Job Opening page without saving any changes to the current row. If you previously used the <b>Save and Add Another</b> button, the data that was already saved is not canceled.

## Adding Screening Questions to a Job Opening

This topic discusses the Screening Questions section on the Job Opening page.

### Pages Used to Add Screening Questions to a Job Opening

<i>Page Name</i>	<i>Definition Name</i>	<i>Usage</i>
<a href="#">Job Opening Page: Screening Questions Section</a>	HRS_JOB_OPENING	Enter screening questions for a job opening.
<a href="#">Answers to Screening Questions Page</a>	HRS_JO_ANSWER_SEC	Review the correct and incorrect answers to a multiple-choice screening question, and review the points that are awarded for each answer.
<a href="#">Assign Evaluators Page</a>	HRS_OE_EVAL_SEC	Review the full text of an open-ended question, and assign evaluators who will give scores to applicants' answers to that question.
<a href="#">Select Question Sets Page</a>	HRS_QSET_ADD_SEC	Choose a question set so that the system can add all included questions to the job.

### Job Opening Page: Screening Questions Section

Use the Screening Questions section on the Job Opening page (HRS\_JOB\_OPENING) to configure screening questions for the job opening.

---

**Note:** The template for the job opening controls whether this section appears and, if so, where it appears.

---

Navigation:

- **Recruiting > Create Job Opening**

Click the **Continue** button on the Primary Job Opening page and, if necessary, on the Combined Profile Information page.

- **Recruiting > Search Job Openings**

Click the link for a job opening in the search results, then click the Job Details tab, then click the link for the type of job opening data you want to access.

This example illustrates the Job Opening page: Screening Questions section.

**Employment Questions** ?

*Question	Question Order	Required	Action		
<input type="text" value=""/>	<input type="text" value=""/>	<input type="checkbox"/>	<a href="#">View Answers</a>		

---

**Skills Questions** ?

*Question	Question Order	Required	Action		
<input type="text" value="21 Yrs"/>	<input type="text" value="3"/>	<input type="checkbox"/>	<a href="#">View Answers</a>		
<input type="text" value="Ever had a felony conviction?"/>	<input type="text" value="4"/>	<input type="checkbox"/>	<a href="#">View Answers</a>		
<input type="text" value="Can you work in this country?"/>	<input type="text" value="5"/>	<input type="checkbox"/>	<a href="#">View Answers</a>		
<input type="text" value="Clinical Experience"/>	<input type="text" value="1"/>	<input type="checkbox"/>	<a href="#">View Answers</a>		
<input type="text" value="Nursing School"/>	<input type="text" value="2"/>	<input type="checkbox"/>	<a href="#">View Answers</a>		
<input type="text" value="Can you lift a 25 lb. object?"/>	<input type="text" value="6"/>	<input type="checkbox"/>	<a href="#">View Answers</a>		

### Default Screening Questions from the Job Opening Template

If there is a default question set in the job opening template, the system adds those questions to the Screening Questions grid when you first create the job opening. If you change the template association, the questions are not removed, though additional questions may be added.

The system continues to reload questions from the job opening template until the job opening is in Open status. This means that any manually deleted questions are added back while the job opening is in Draft or Pending status. Also, if new questions are associated with the job opening template, the system adds those to the job opening too. (Other template changes, however, do not carry over to existing job openings.)

After the job opening goes into Open status, the system no longer refreshes the question list.

### Default Screening Questions from the Resume Template

If there are prescreening questions in the resume template for the job opening, the system adds those questions to the Screening Questions grid when you first create the job opening. These questions, unlike the questions from the job opening template, do not normally get reloaded after the initial job creation, regardless of the job opening status. However, if you change the template association, additional questions may be added.

## Screening Questions

<b>Field or Control</b>	<b>Description</b>
<b>Question</b>	<p>Select a screening question. Screening questions are defined on the Question Definition page.</p> <p>Questions that you enter here are available to be used by any of the screening levels that you run for this job opening (except that you can't use open-ended questions for prescreening or online screening). Applicant's answers are collected during the online application process in Candidate Gateway.</p>
<b>Question Order</b>	<p>Enter numbers to control the order that the questions appear in the online application. If you load questions from a question set that specified order numbers, then those order numbers are the default values in the job opening.</p> <p>Review any default values carefully. Default values might not be unique, depending on the order numbers that were assigned in the question set definitions, and it is up to you to specify an unambiguous question order.</p> <p>Because this field accepts only integers, consider using non-consecutive numbers to make it easier to insert additional questions between existing questions.</p> <hr/> <p><b>Note:</b> If the <b>Randomize Screening Questions</b> field on the Recruiting Installation - Jobs page has a <i>Yes</i> value, then the system disregards the question order and presents questions to applicants in random order.</p> <hr/>

<b>Field or Control</b>	<b>Description</b>
<b>Action</b>	<p>For multiple-choice questions, a <b>View Answers</b> link appears. Click this link to access the Answers to Screening Questions page, where you can review the answer choices and their default point values. When you set up screening criteria for the job opening, you can override the default values.</p> <p>For open-ended questions, an <b>Enter Evaluators</b> link appears. Click this link to access the Assign Evaluators page, where you identify the users who will evaluate and award points to applicants' answers. An evaluator can be any person in the PeopleSoft Human Resources system who has appropriate security access. It is possible to assign yourself as an evaluator.</p> <p>When evaluating open-ended questions, evaluators see only the question and the answer; no applicant information is visible.</p> <hr/> <p><b>Note:</b> Always assign evaluators to open-ended questions. Only the assigned evaluators can award an applicant points for the question, so questions without evaluators are never awarded any points during screening</p> <hr/> <p>See <a href="#">Evaluating Answers to Open-Ended Screening Questions</a>.</p>
<b>Add Screening Questions</b>	Click to add another row to the <b>Screening Questions</b> grid.
<b>Load from Question Sets</b>	Click to access the Select Question Sets page, where you can select one or more question sets whose questions will all be added to the list of screening questions.

**Related Links**

[Setting Up the Skills and Employment Questions](#)

**Answers to Screening Questions Page**

Use the Answers to Screening Questions page (HRS\_JO\_ANSWER\_SEC) to review the answers to a multiple-choice screening question and to review the default points associated with each answer.

Navigation:

Click the **View Answers** link for a multiple-choice screening question on the [Job Opening Page: Screening Questions Section](#)

This example illustrates the Answers to Screening Questions page.

**Answers to Screening Questions**

**Question**  
Are you willing to work overtime periodically ?

Answers		
Answer	Default Points	Correct Answer
No	0	<input type="checkbox"/>
Yes	0	<input checked="" type="checkbox"/>

Return

Use this page to review answer information, including default point values for each answer.

To change the list of answers, the default points for an answer, or whether an answer is considered correct, use the Question Definition page.

To change the point values for answers for a particular job opening, use the [Define Screening Points Page \(Rating Scale Points\)](#) in the job opening.

## Assign Evaluators Page

Use the Assign Evaluators page (HRS\_OE\_EVAL\_SEC) to review the full text of an open-ended question and to assign evaluators who will give scores to applicants' answers.

Navigation:

Click the **Enter Evaluators** link for an open-ended screening question on the [Job Opening Page: Screening Questions Section](#).

This example illustrates the Assign Evaluators page.

**Assign Evaluators**

**Question**  
Describe the process for making a cup of coffee. Your answer should not exceed 500 words.

**Evaluators for Open Ended Questions**

Empl ID	Name			
<input style="width: 90%;" type="text" value="KU0001"/> <input style="width: 5%; border: none; border-radius: 50%; background-color: #ccc; text-align: center; font-size: 1em; cursor: pointer;" type="button" value="Q"/>	Douglas Lewis	<input style="border: none; border-radius: 50%; background-color: #ccc; width: 20px; height: 20px;" type="button" value="+"/>	<input style="border: none; border-radius: 50%; background-color: #ccc; width: 20px; height: 20px;" type="button" value="🗑️"/>	

<b>Field or Control</b>	<b>Description</b>
<b>Empl ID</b>	Enter the Employee ID of the users who are assigned to evaluate applicants' responses to this open-ended question.  If you remove an evaluator from this page, the evaluator's completed evaluations are <i>not</i> affected. Only pending evaluations (which appear in the Recruiter Alerts pagelet) are removed.

## Select Question Sets Page

Use the Select Question Sets page (HRS\_QSET\_ADD\_SEC) to choose a question set so that the system can add all included questions to the job opening.

Navigation:

Click the **Load from Question Sets** link on the [Job Opening Page: Screening Questions Section](#).



This example illustrates the Select Question Sets page.

### Select Question Sets

**Question Set**

☰ 🔍
1-21 of 21

Select	Question Set ID	Description
<input checked="" type="checkbox"/>	1008	Variety of questions
<input type="checkbox"/>	1009	3 General Knowledge Questions
<input type="checkbox"/>	1011	Seasons
<input type="checkbox"/>	1012	Basic Eligibility - 0025
<input type="checkbox"/>	1013	Customer Focus
<input type="checkbox"/>	1014	Overtime
<input type="checkbox"/>	1015	Bedding
<input type="checkbox"/>	1016	Cooking techniques
<input type="checkbox"/>	1017	Customer Response
<input type="checkbox"/>	1018	Food Question Set
<input type="checkbox"/>	1019	Fed eRecruit Personnel Questns
<input type="checkbox"/>	1020	General SCR with Open Ended Q
<input type="checkbox"/>	1021	Ethics And Integrity
<input type="checkbox"/>	1022	Quick Personality Review
<input type="checkbox"/>	1023	Health Self Certification

The Question Set grid lists all questions sets in the system. Select one or more whose questions you want to add to the job opening, then click the **OK** button.

## Setting Up Screening for a Job Opening

This topic provides overviews of screening settings in the job opening and of U.S. federal screening setup. It then discusses the Applicant Screening section on the Job Opening page and provides detailed information for setting up screening criteria and scoring.

## Pages Used to Set Up Screening for a Job Opening

<b>Page Name</b>	<b>Definition Name</b>	<b>Usage</b>
<a href="#">Job Opening Page: Applicant Screening Section</a>	HRS_JOB_OPENING	Enter screening options for a job opening.
<a href="#">Add Screening Levels Page</a>	HRS_SCR_ADD_SEC	Add screening levels to the job opening.
<a href="#">Job Opening - Screening Criteria Page</a>	HRS_JO_SCR_DTL	Add screening criteria to screening levels.
<a href="#">Define Screening Points Page (Rating Scale Points)</a>	HRS_JO_SCR_RTG_SEC	Review and override points for ratings on a rating scale.
<a href="#">Define Screening Points Page (Points for Questions)</a>	HRS_JO_SCR_QSN_SEC	Review and override points for answers to a multiple-choice question. Review and override the maximum point value of open-ended questions.
<a href="#">View Text ID Text Message Page</a>	HRS_JO_SCR_VW_SEC	View the complete text of the explanatory message, pass message, or fail message that you selected for prescreening or online screening.

## Understanding Screening Settings in the Job Opening

Screening is the process used by recruiters to evaluate a list of potential candidates and narrow the list to a few qualified applicants that can be interviewed or hired. A job opening can have multiple screening processes, or screening *levels*, and each screening level can evaluate different criteria and use different processing rules.

### Screening Level Selection

The Screening Options section on the Job Opening page includes a grid containing an ordered list of screening levels for the job. This section also includes a check box that you use to indicate whether applicants must pass the previous screening level before being included in subsequent screening levels.

If you include a screening level for prescreening, it is always the first screening level. If you include a screening level for online screening, it always goes before any other screening levels except the prescreening screening level.

See [Understanding Prescreening and Online Screening](#).

### Screening Criteria Selection

The screening level definitions that you reference from the job opening include default processing rules, but they do not include any actual screening criteria. Use the Job Opening - Screening Criteria page to select job opening-specific criteria for each level.

When you access the Job Opening - Screening Criteria page for a screening level, the grid where you select screening criteria is automatically populated with certain attributes of the job opening. You then select which of the available items to use in the screening level that you are configuring.

The job opening attributes that are available for use as screening criteria fall into four groups:

- *Job Preferences* come from fields that you populate in the Job Information and Salary Information sections of the Job Opening page.

Fields where you do not enter data do not appear in the list of available screening criteria.

General requirements come from these job opening attributes: regular/temporary, full-time/part-time, start date, standard hours, shift, travel percent, minimum and maximum age, sex, citizenship status, recruiting location, minimum salary, and minimum grade.

- *Education and experience* requirements come from the Education and Experience section of the Job Opening page.

These requirements indicate the number of years of experience required for applicants with various levels of education. Each set of values—a degree and the years of experience required of applicants with that degree—is processed separately. To prevent the system from penalizing someone with the correct amount of experience but a higher degree, the job opening should include rows for every degree above the minimum requirement. To indicate that any amount of experience is acceptable for applicants with a given degree, enter 0 as the experience requirement for that degree.

---

**Note:** When the screening process evaluates whether an applicant meets particular education & experience requirements, it fails applications where there are no work experience entries with start dates, even if there are zero years of work experience required.

---

- *Skills Questions* and *Employment Question* are created outside of the job opening and then added to the Screening section of the Job Opening page.

Skills questions and Employment questions enable you to ask multiple-choice, single choice, date type, numeric or open-ended questions to applicants who apply online. Open-ended questions must be associated with one or more evaluators who can judge the applicant's answer and award points.

---

**Note:** Unlike the other types of screening criteria, screening questions are useful only if applicants can submit applications online. It is not possible to enter answers to screening questions in the Application Details page.

---

- *Profile content types* are job opening attributes whose properties are configured in the Manage Profiles module in PeopleSoft Human Resources and then configured for use in Talent Acquisition Manager.

For example, Oracle delivers content types for competencies and language skills. If a job opening includes sections for these content types (which depends on the job opening template that is associated with the job opening), then any values that a recruiter enters in these sections (specific competencies and specific language skills) are included in the criteria list on the Job Opening - Screening Criteria page.

Profile content types must be explicitly configured for use in screening.

See [Configuring Profiles for Recruiting](#).

The following table lists general requirements that can be used for screening and shows the corresponding applicant data fields:

<b>Job Opening Field</b>	<b>Applicant Field</b>
Regular/Temporary	I am looking for the following kind of work: Regular, Temporary, or Either
Full/Part Time	I want to work: Full Time, Part Time, or Either
Start Date	I can start my new job on or after <date>
Standard Hours/Week	I want to work <number> hours per week
Shift	I want to work the following shift(s)
Travel Percentage	I am willing to travel <specified percentage of time>
Minimum Salary	I require a minimum pay of
Recruiting Location	I would prefer a work location in or around <location>  (Screening looks at both the first and second choice entered by the applicant.)

The following table lists additional fields that can be used for screening in US Federal Implementations:

<b>Federal Job Opening Field</b>	<b>Applicant Field</b>
(USF) Citizenship Status	Are you a U.S. Citizen?
(USF) Gender	Gender
(USF) Maximum Age	Date of Birth
(USF) Minimum Age	Date of Birth
(USF) From Grade	(USF) Minimum Acceptable Pay Grade

### Screening Criteria Point Values

When you define the job-specific criteria for a screening level, you must also provide a point value for each item that you select. The criteria grid includes a points field that displays the maximum point value for each item. Points can be positive or negative.

You assign point values differently depending on the type of criteria:

- For criteria that is either met or not met, the points field is editable so you can directly enter a point value.

Use this method of assigning point values for all general requirements, all education and experience requirements, and certain content types such as licenses that an applicant either has or does not have.

For example, if there is a general requirement that the applicant be at least 18 years old, the applicant either does or doesn't meet the requirement. Therefore, you can enter the point value for this requirement directly on the Job Opening - Screening Criteria page.

- For content types that are associated with rating scales (such as competencies), click a link to access a page that lists the possible ratings, and enter the point value for each rating.

Default point values come from the content type definition, but you can override these defaults.

Applicants receive the points that correspond to their rating (as long as the rating type for the applicant's rating matches the required rating type). Unrated applicants receive no points, so it is important that applicants be rated before you run a screening level that evaluates a competency or other qualification with a rating scale.

- For single choice, multiple-choice, Date type and Numeric questions, click a link to access a page that lists the possible answers, and enter the point value for each answer.

Default point values come from the question definition. You can assign point values to both correct and incorrect questions. If there multiple correct answers, the total value of the question is the sum of the point values of all correct answers.

Applicants receive the points that correspond to the answer or answers that they provided. They receive no points for unanswered questions.

- For open-ended questions, click a link to access a page where you enter the maximum point value.

The default maximum point value comes from the question definition.

Applicants receive the average score from all evaluators. If some, but not all, evaluators have entered points for the answer, only the completed evaluations are considered. Applicants receive no points for unevaluated questions.

## Screening Level Processing Rules

The Job Opening - Screening Criteria page also includes fields that you use to:

- Indicate the percent of the total available points that an applicant needs to earn to pass the screening level.
- Assign dispositions to screened applicants.
- Assign overall screening level scores to screened applicants.
- Send letters to rejected applicants.

Letters can either be sent through email when the rejected disposition is applied, or letters can be generated and printed in batch.

These settings are all identical to the corresponding fields in the screening level definition, and, in fact, are populated based on the default values in the screening level definition. You can override these defaults as needed.

See [Understanding Screening Levels](#).

## (USF) Understanding U.S. Federal Screening Setup

This overview discusses the U.S. federal screening process and the screening configuration options that Talent Acquisition Manager provides to support this process.

---

**Important!** Oracle provides options that you can use to achieve compliance, but you are responsible for configuring the system to comply with applicable regulations.

---

### Federal Screening and Ranking

U.S. government agencies follow a defined screening and ranking process to produce a ranked list of eligible candidates for a job opening. Applicants are ranked according to the manual classification of screening scores as qualified, well qualified, or best qualified along with factors such as a veteran's preference and the use of tie breaker functionality.

Applicants typically earn points in three stages:

1. An initial screening level that you configure to be worth a fixed amount of points to applicants who pass.
2. A second screening level that you set up to use a process known as *transmutation*, which converts the raw score based on a transmutation portion that you define.

For example, if you configure the first screening level to be worth 70 points, and you need the total for both screening levels to be on a scale that goes to 100, then you would use 30 as your transmutation portion. The system would then convert the applicant's raw points for the transmuted screening level to a scale that goes up to 30.

There is a configuration option that you use to determine whether to use an hourly or salaried transmutation process for a particular screening level in a job opening.

3. Veterans preference points that are added to the final screening score.

See [\(USF\) Setup Veterans Preference Page](#).

### Salaried Transmutation Calculation

The salaried transmutation process calculates the percentage of the total possible raw points that the applicant received for the screening level and then applies that percentage to the total possible points (the transmutation segment that you specify) to calculate the applicant's score for the screening level.

For example, Brian Waters is being screened using salaried transmutation and a transmutation segment of 30. His raw score is 15 out of a possible 20 points, or 75% of the possible points for the screening level. He therefore receives 75% of 30, or 22.5 as his score for this screening level. Because scores are always whole numbers, Brian's total is rounded up to 23 points.

## Hourly Transmutation Calculation

The hourly transmutation process calculates the score somewhat differently because of a requirement that the applicant receive at least half of the available points. It is typically used when the criteria in the first and second screening levels are identical, and the first screening level is configured to award points if the applicant achieves half of the total possible points. That is, if an applicant achieved 18 points out of a possible 20 points to pass the first screening level, then there are 18 - 10, or 8 points left to be transmuted in the second level.

The hourly transmutation calculation determines what percent of the transmutation segment to award using the ratio of (the applicants points above the 50% threshold) to (the total available points above the 50% threshold).

For example, Mary Stone is being screened using hourly transmutation and a transmutation segment of 30. Her raw score is 15 out of a possible 20 points.

Rather than determining the ratio of 15 (earned) to 20 (possible) points, the system first subtracts half of the available points, or 10, from both numbers — those ten points should have been accounted for in the preceding screening level. The result is that the system performs the transmutation based on these adjusted numbers: 5 earned points and 10 possible points.

Because Mary's adjusted earned points are half of the adjusted available points, her final score for the screening level is half of 30, or 15.

## Rules for Ranking Applicants

At the end of the applicant screening process, applicants' cumulative screening scores are adjusted for veterans preference to produce a final score. Next, you qualify the applications by manually entering score thresholds and applying those thresholds to classify applicants as qualified, well-qualified, or best-qualified based on their scores.

---

**Note:** Applicants cannot be ranked unless the manual process of qualifying them has been completed.

---

The system then considers these qualification classifications along with the applicants' priority processing status and places applicants in these four categories:

- Category 1: Qualified, well qualified, and best qualified applicants with *Must Select* priority placement.
- Category 2: Well qualified and best qualified applicants with *Must Consider* priority placement.
- Category 3: Best qualified applicants with no priority placement.
- Category 4: Qualified and well qualified applicants with no priority placement.

Rules that you configure for each job opening control which categories of applicants are included in the final ranking. The rules enable you to include different categories for competitive applicants and noncompetitive applicants.

You can also choose whether veterans receive preference in tie-breakers.

## Prerequisites

Before you configure screening for a job opening, you must set up the screening level definitions that you will use, and you must enter data in all of the job opening fields that you intend to use as screening criteria.

If you want the system to place a default set of screening levels in newly created job openings, you can associate screening levels to screening template and screening templates to recruitment templates. However, this task is optional.

## Job Opening Page: Applicant Screening Section

Use the Applicant Screening section on the Job Opening page (HRS\_JOB\_OPENING) to enter screening options for a job opening.

---

**Note:** The template for the job opening controls whether this section appears and, if so, where it appears.

---

Navigation:

- **Recruiting > Create Job Opening**

Click the **Continue** button on the Primary Job Opening page and, if necessary, on the Combined Profile Information page.

- **Recruiting > Search Job Openings**

Click the link for a job opening in the search results, then click the Job Details tab, then click the link for the type of job opening data you want to access.

This example illustrates the Job Opening page: Applicant Screening section.

Applicant Screening ?

Max Total Points   Must Pass Previous Levels

Applicant Screening ?

Sequence	Screening Levels	
1	Pre Screening	
2	Online Screening	
3	Preliminary	
4	Final	

The following illustration shows how the screening section looks in a federal implementation:



This example illustrates the Applicant Screening section in a U.S. federal implementation.

**Note:** In the screening section on the Job Opening page, all fields except for the **Transmutation USF** check box (visible only in U.S. federal implementations) have default values that come from the screening template.

<b>Field or Control</b>	<b>Description</b>
<b>Max Total Points</b>	Enter the maximum points that an applicant can accumulate across all screening levels. During the applicant ranking process in U.S. federal implementations, the Rank Applicants page shows applicants' final scores both as numbers and as a percentage of the value you enter here, which is typically 100.
<b>Must Pass Previous Levels</b>	<p>Select this check box if the applicant must pass the previous screening level before being evaluated for the next screening level. This does not apply to:</p> <ul style="list-style-type: none"> <li>The first screening level, as indicated by the lowest sequence number.</li> <li>Prescreening or online screening levels.</li> </ul> <p>Prescreening is always the first screening level anyway. Online screening can be preceded by prescreening, but because failing prescreening stops the online application process, applicants cannot even reach the online screening phase without passing any preliminary prescreening.</p>

**(USF) Federal**

These fields are identical to the corresponding fields in the screening template.

<b>Field or Control</b>	<b>Description</b>
<b>Augmented Score Limit</b>	Enter the total number of augmentation points that can be awarded. You can configure screening to award augmentation points for certain competencies or accomplishments that are not required for the position but may be given consideration in the selection process.
<b>Tie Break Number</b>	Enter a random number to use in the tie-breaking algorithm for ranking applicants.
<b>Raw Veterans Pref Score Limit</b> (raw veterans preference score limit)	Enter the maximum number of points that can be added to an applicant's final screening score for veterans preference. The number that you enter overrides veterans preference score higher than the limit.

### **(USF) Competitive and Non-Competitive**

These fields are identical to the corresponding fields in the screening template.

The same fields appear in the Competitive and Non-Competitive group boxes so that you can separately configure ranking options for competitive and noncompetitive applicants.

<b>Field or Control</b>	<b>Description</b>
<b>Rank Candidates of Category 1, Rank Candidates of Category 2, Rank Candidates of Category 3, and Rank Candidates of Category 4</b>	<p>At the end of the applicant screening process, score thresholds are applied to classify the candidates as qualified, well-qualified, or best-qualified. The system then considers these qualification classifications along with the applicants's priority processing status and places applicants in these four categories:</p> <ul style="list-style-type: none"> <li>• Category 1: Qualified, well qualified, and best qualified applicants with <i>Must Select</i> priority placement.</li> <li>• Category 2: Well qualified and best qualified applicants with <i>Must Consider</i> priority placement.</li> <li>• Category 3: Best qualified applicants with no priority placement.</li> <li>• Category 4: Qualified and well qualified applicants with no priority placement.</li> </ul> <p>Select check boxes for each category of applicants that are to be included in the final applicant ranking that produces the Certificate of Eligibles.</p> <p>See <a href="#">Understanding Priority Placement Processing</a>.</p>
<b>Veteran Preferred in Tie Break</b>	<p>Select this check box if you want applicants with veteran status to win tiebreakers during the ranking process.</p>

## Applicant Screening

This grid lists the screening levels for the job opening.

<b>Field or Control</b>	<b>Description</b>
<b>Sequence</b>	<p>The sequence determines the order in which you run the listed screening levels. The screening template that provides the default list of screening levels also sets their default sequence.</p> <p>You cannot change the sequence directly. However, screening levels that you add to the list are automatically put at the end of the sequence. So to change the order of the default screening levels, you can remove screening levels from the list and re-add them in the desired order.</p> <p>Regardless of how screening levels are added to the list, the sequences starts with the prescreening level (if any), followed by the online screening level (if any), followed by all other screening levels.</p>
<b>Screening Levels</b>	<p>Displays the name of the screening level.</p> <p>Standard screening levels can appear in the list multiple times. However, the list can include a maximum of one prescreening level and one online screening level.</p> <p>Click the link to access the Job Opening - Screening Criteria page so that you can choose screening criteria and, if necessary, override default processing rules.</p> <hr/> <p><b>Note:</b> After you click a screening level, the system saves the job opening before displaying the Job Opening - Screening Criteria page.</p> <hr/>
<b>Transmutation USF</b>	<p>Select this check box for the screening level where transmutation is applied during U.S. federal screening. This is the second of the two levels whose scores are combined to produce a cumulative score of up to 100 points.</p> <p>When you select this check box, the system validates that the preceding screening level does not use transmutation, but you must verify that all screening levels are set up correctly.</p> <hr/> <p><b>Note:</b> A transmutation screening level is always preceded by a non-transmutation screening level.</p> <hr/> <p>When you select this check box, you must enter additional transmutation information in the Job Opening - Screening Criteria page.</p> <p>See <a href="#">(USF) Understanding U.S. Federal Screening Setup</a>.</p>

## Add Screening Levels Page

Use the Add Screening Levels page (HRS\_SCR\_ADD\_SEC) to add screening levels to the job opening.

Navigation:

Click the **Add Screening Options** link on the Job Opening Page: Applicant Screening Section.

This example illustrates the Add Screening Levels page.

×
Help

Add Screening Levels

Add Screening Options

Select	Screening ID	Description
<input type="checkbox"/>	3	Basic
<input type="checkbox"/>	4	Min Quals
<input type="checkbox"/>	6	Ranking
<input type="checkbox"/>	1000	Basic Screening
<input type="checkbox"/>	1001	Basic Eligibility
<input type="checkbox"/>	1002	Minimum Qualifications
<input type="checkbox"/>	1003	Quality Ranking
<input type="checkbox"/>	1004	Preliminary
<input type="checkbox"/>	1005	Final
<input type="checkbox"/>	1012	Pre Screening
<input type="checkbox"/>	1013	Online Screening

OK

Cancel

The page lists the screening levels that your organization has defined. Select the check box next to the screening levels that you want to add, then click the **OK** button.

---

**Note:** A job opening can have only one prescreening level and only one online screening level.

---

## Job Opening - Screening Criteria Page

Use the Job Opening - Screening Criteria page (HRS\_JO\_SCR\_DTL) to add screening criteria to screening levels.

Navigation:

Click a screening level link in the **Applicant Screening** grid on the Job Opening Page: Applicant Screening Section.

This is the first of two examples that illustrate the Job Opening - Screening Criteria page.

**Screening Criteria**

**Job Opening ID** 290037      **Status** 010 Open  
**Job Posting Title** Manager-Employee Relations      **Business Unit** GBIBU (Global Business Institute BU)  
**Job Code** 6000060 (Manager-Employee Relations)      **Department** 13000 (Finance and Administration)  
**Position Number** 19000025 (Manager-Employee Relations)

**Screening Option Description** Screening ID 1013

Name Online Screening

Pass Status

Pass Reason

Fail Status

Fail Reason

Explain Text ID  [View Explanatory Message](#)

Pass Text ID  [View Pass Message](#)

Fail Text ID  [View Fail Message](#)

Pass Email     Fail Email

**Scoring Definition**

**Assign Points**

Percent Needed to Pass

Maximum Points to Assign

Points Assigned for Pass

Use Raw Points

Points Assigned for Fail

Manually Assign Status

This is the second of two examples that illustrate the Job Opening - Screening Criteria page.

**Screening Requirements** 1-35 of 35

Screening Type	Item	Description	Edit Details	Use in Screening	Required to Pass	Points
Job Preferences	Minimum Grade : 004			<input type="checkbox"/>	<input type="checkbox"/>	0
Job Preferences	RS Location : 37			<input type="checkbox"/>	<input type="checkbox"/>	0
Employment Question	Question: Date		<a href="#">Edit Details</a>	<input type="checkbox"/>	<input type="checkbox"/>	0
Employment Question	Question: Value to Org		<a href="#">Open Ended</a>	<input type="checkbox"/>	<input type="checkbox"/>	0
Employment Question	Question: Sensitive Info		<a href="#">Edit Details</a>	<input type="checkbox"/>	<input type="checkbox"/>	0
Employment Question	Question: Rumors at Office		<a href="#">Edit Details</a>	<input type="checkbox"/>	<input type="checkbox"/>	0
Employment Question	Question: Multitasking		<a href="#">Edit Details</a>	<input type="checkbox"/>	<input type="checkbox"/>	0
Employment Question	Question: Mistake Handling		<a href="#">Open Ended</a>	<input type="checkbox"/>	<input type="checkbox"/>	0
Employment Question	Question: Experience		<a href="#">Edit Details</a>	<input type="checkbox"/>	<input type="checkbox"/>	0
Employment Question	Question: Computer Literacy		<a href="#">Edit Details</a>	<input type="checkbox"/>	<input type="checkbox"/>	0
Employment Question	Question: Vision		<a href="#">Open Ended</a>	<input type="checkbox"/>	<input type="checkbox"/>	0
Skills Question	Question: Overtime		<a href="#">Edit Details</a>	<input type="checkbox"/>	<input type="checkbox"/>	0
Skills Question	Question: Confidential Mail		<a href="#">Edit Details</a>	<input type="checkbox"/>	<input type="checkbox"/>	0
Skills Question	Question: Employee Input and Development		<a href="#">Edit Details</a>	<input type="checkbox"/>	<input type="checkbox"/>	0
Skills Question	Question: Issue Resolution		<a href="#">Edit Details</a>	<input type="checkbox"/>	<input type="checkbox"/>	0
Skills Question	Question: Workload Management		<a href="#">Edit Details</a>	<input type="checkbox"/>	<input type="checkbox"/>	0

Total Screening Points

## Screening Option Description: Page Elements for All Screening Levels

Use this group box to define the rules for assigning applicant statuses after screening results are determined. The default values come from the screening level definition.

**Note:** For standard screening levels, the disposition is assigned only when screening results are explicitly applied. For prescreening, the fail status is applied as soon as the applicant fails, but the pass status is not applied until the applicant submits the application. For online screening, the system applies the results immediately after processing the applicant.

<b>Field or Control</b>	<b>Description</b>
<b>Pass Status and Pass Reason</b>	<p>Optionally select the disposition (and, if desired, an associated reason) to assign when an application passes this screening level.</p> <p>Typically, you assign the <i>Screen</i> disposition for standard screening levels, and you either leave the fields blank or select the <i>Applied</i> disposition for online screening and prescreening.</p> <p>For prescreening, the Pass Status is not applied until the application is submitted.</p>
<b>Fail Status and Fail Reason</b>	<p>Select the disposition (and, if desired, an associated reason) to assign applicants who fail this screening level. This setting is required for prescreening and optional for standard screening and online screening.</p> <p>Typically, you assign the <i>Reject</i> disposition for standard screening levels, the <i>Failed Prescreening</i> disposition for prescreening, and the <i>Reject Online Screening</i> disposition for online screening.</p>

## Screening Option Description: Page Elements for Standard Screening Levels

These page elements appear only for standard screening levels (levels that are not for prescreening or online screening).

<b>Field or Control</b>	<b>Description</b>
<b>Letter</b>	<p>Select a letter to send to applicants who fail this screening level. The letter is added to the queue for the Generate Recruitment Letter (HRSLETTR) process after screening results are applied.</p> <p>The drop-down list box includes all of the letters in the HRS_APP_LET report definition, which includes letters for various purposes. Take care to select the appropriate letter. The sample rejection letter that Oracle delivers is HRS_APP_LETTER_IR.</p> <p>See <a href="#">Generate Recruitment Letters Page</a>.</p>
<b>Send Letter as Email When Results are Applied</b>	<p>Select this check box to have the system send failed applicants an email with the text of the selected rejection letter. The system sends the email (and creates a contact note) after the results for the screening level are applied. If you choose to send the letter as email, the letter is not added to (or is removed from) the queue for the Generate Recruitment Letter process.</p> <p>Only applicants who have provided an email address can receive their rejection letter through email.</p>
<b>(USF) Hourly Transmutation</b>	<p>If the screening level uses transmutation to calculate applicants' scores (that is, if you selected the <b>Transmutation USF</b> check box in the grid that lists all screening levels for the job opening), select this check box to use hourly transmutation rules. Leave the check box deselected to use salaried transmutation rules.</p> <p>See <a href="#">(USF) Understanding U.S. Federal Screening Setup</a>.</p>

### Screening Option Description: Page Elements for Prescreening and Online Screening

These page elements appear only for screening levels for prescreening and online screening.

This example illustrates the Screening Option Description section for online screening and prescreening.

The screenshot shows a form titled "Screening Option Description" with the following elements:

- Name:** Online Screening
- Screening ID:** 1013
- Pass Status:** A dropdown menu.
- Explain Text ID:** A search field with a magnifying glass icon and a link to "View Explanatory Message".
- Pass Reason:** A dropdown menu.
- Pass Text ID:** A search field with a magnifying glass icon and a link to "View Pass Message".
- Fail Status:** A dropdown menu.
- Fail Text ID:** A search field with a magnifying glass icon and a link to "View Fail Message".
- Fail Reason:** A dropdown menu.
- Pass Email:** A checkbox.
- Fail Email:** A checkbox.



<b>Field or Control</b>	<b>Description</b>
<b>Explain Text ID</b>	<p>Select the ID for the message that Candidate Gateway presents to applicants when they reach the point where this screening level is to be processed. Use this message to give the applicant instructions or other relevant information.</p> <p>For prescreening, explanatory text is required. The text appears under the Prequalification Terms heading on the application process Start step. Applicants must agree to these terms before continuing.</p> <p>For online screening, explanatory text is optional. The texts appears on the application process Review and Submit step so that applicants can be informed that screening will occur when the application is submitted.</p> <p>The screening level definition does not include a field for a default explanatory message, so you must enter this information on each job opening that requires an explanatory message.</p>
<b>Pass Text ID</b> and Fail Text ID	<p>Select the IDs for the messages that Candidate Gateway presents to applicants who pass and who fail this screening level.</p> <p>Messages are required for prescreening and optional for online screening. Default values come from the screening level definition.</p> <hr/> <p><b>Important!</b> In Fluid Candidate Gateway, applicants who pass prescreening for all jobs in an application do not see any prescreening messages. Therefore, organizations that use Fluid Candidate Gateway should not use the pass message for any critical information.</p> <p>Applicants do see the pass message if the prescreening results are a mix of pass and fail, and the message is still sent to the applicant if you select the <b>Pass Email</b> check box.</p> <hr/>
<b>View Explanatory Message, View Pass Message,</b> and View Fail Message	Click these links to access the View Text ID Text Message page, where you can review the complete test of the selected message.
Pass Email and Fail Email	Select these check boxes to make the system send screened applicants an email containing the pass message or fail message, depending on the screening results. The system sends the email in addition to displaying the message online.

## Scoring Definition and Assign Points

Use the fields in this group box to define the rules for how screening levels will be scored. The default values come from the screening level definition.

See [Screening Definition Page](#).

<b>Field or Control</b>	<b>Description</b>
<p><b>Percent Needed to Pass</b></p>	<p>Enter the minimum percentage amount of the total possible points that an applicant must have to pass the screening level. If you leave this field blank, the pass threshold is 0%, and all applicants will pass.</p> <hr/> <p><b>Note:</b> Because an applicant can have only one highest level of education, applicants can receive points for only one of the Education &amp; Experience rows. If you screen based on more than one row of Education &amp; Experience criteria, applicants will never be able to earn 100% of the points that can be awarded for the screening level.</p> <hr/> <p>For U.S. Federal salaried screening, the first screening level typically requires applicants to achieve 100% to pass.</p> <p>For U.S. Federal hourly screening, the first screening level typically requires applicants to achieve 50% to pass.</p> <p>For both types of U.S. Federal screening, you can leave these fields blank for the second screening level, which uses transmutation to calculate a score.</p>
<p><b>Use Raw Points</b></p>	<p>Select this check box if you want scores for the screening level to be the sum of the actual points that the applicant earned for the screening level. When this check box is selected, transmutation is not available.</p> <p>If you select this check box, do not enter values in the <b>Maximum Points to Assign, Points Assigned for Pass, or Points Assigned for Fail</b> fields.</p>
<p><b>Maximum Points to Assign</b></p>	<p>Use this field to optionally enter a maximum number of points to assign.</p>

<b>Field or Control</b>	<b>Description</b>
<b>(USF) Transmutation Segment</b>	<p>For a screening level whose points are calculated using transmutation, enter the number of points that this segment is worth.</p> <p>For example, if you configure the first screening level to be worth 70 points, and you need the total for both screening levels to be on a scale that goes to 100, then you would use <i>30</i> as your transmutation portion. The system would then convert the applicant's raw points for the transmuted screening level to a scale that goes up to 30. The specific calculation depends on whether you selected the <b>Hourly Transmutation</b> check box.</p>
<b>Points Assigned for Pass and Points Assigned for Fail</b>	<p>Enter scores to assign to all applicants who pass or fail this screening level. If you leave this field blank, the system enters <i>0</i>. You can enter negative points.</p>
<b>Manually Assign Status</b>	<p>Select this check box to allow recruiters to manually override an applicant's pass/fail status for a screening level.</p> <p>When this check box is selected, the rest of the scoring-related page elements become read-only. To modify the read-only fields, first deselect the <b>Manually Assign Status</b> check box, then make the changes before selecting the check box again.</p>

## Screening Requirements

This grid displays all available screening criteria so that you can select which items to use in the screening level.

See [Understanding Screening Settings in the Job Opening](#) [Making Content Types Available for Screening](#).

<b>Field or Control</b>	<b>Description</b>
<b>Description</b> (first column)	<p>Displays the type of screening criteria. <i>General Requirements</i> items appear first, then <i>Education &amp; Experience</i> items, then <i>Screening Question</i> items.</p> <p>The remaining items in the grid are job opening attributes based on profile content types. This includes job qualifications such as <i>Competencies</i>, <i>Degrees</i>, and <i>Language Skills</i>. The content type definition provides the descriptive text that appears in this column.</p>

<b>Field or Control</b>	<b>Description</b>
<b>Item and Description</b>	<p>Displays the specific job requirement that is available for screening.</p> <p>For general requirements, screening questions, and education &amp; experience requirements, text in the <b>Item</b> column concatenates the name of the requirement (for example, Full/Part Time) and the value to be matched (for example, Full-Time). The adjacent <b>Description</b> column is blank.</p> <p>For content type items, the text in the <b>Item</b> column is simply the name of the content item as defined in the Manage Profiles content catalog. For example, if the content type is <i>Memberships</i>, the <b>Item</b> column identifies the membership. The next column displays the specific property, such as <i>Membership</i>, that is evaluated during screening.</p> <hr/> <p><b>Note:</b> Settings on the Content Section Configuration page control the profile data that is available for screening.</p> <hr/> <p>See <a href="#">Making Content Types Available for Screening</a>.</p> <p>If the content types uses instance qualifiers to organize content items, the instance qualifier also appears in the Description column. In particular, competencies use the evaluation type (Self, Supervisor/Manager, Peer, and so forth) as instance qualifiers, and therefore the evaluation type appears next to the property name (Proficiency) in the Description column.</p> <p>When setting up screening criteria, you might need rows for more than one evaluation type. For example, external applicants can be screened based on their self-determined proficiency ratings, while internal applicants might be screened based on official competency ratings.</p> <p>See <a href="#">Data Loaded from Profiles</a>.</p>

<b>Field or Control</b>	<b>Description</b>
<b>Edit Details</b>	<p>Displays a link that varies depending on context:</p> <p>The link text is <i>Edit Details</i> for multiple choice questions and for content types such as competencies that provide a rating scale. Click the link to access the Define Screening Points page, where you can assign different scores to different ratings or question answers.</p> <p>The link text is <i>Open Ended</i> for open-ended questions. Clicking this link also opens the Define Screening Points page, but in this mode, the page displays the text of the open-ended question and enables you to override the default maximum point value for the question.</p> <p>This column is blank for other types of qualifications.</p>
<b>Use in Screening</b>	<p>Select this check box if you want the screening process to evaluate whether applicants meet the criteria for this item.</p>
<b>Required</b>	<p>Select this check box if the applicant must have this criteria to pass the screening level. If the system determines that the applicant does not have this criteria (or incorrectly answers this question), the applicant fails the screening level even if the overall point total meets the passing threshold.</p> <p>Online screening, including prescreening, applies this requirement instantly; there is no opportunity for a human to review screening results before applying them. For these screening levels, then, selecting this check box for a question makes it into an immediate disqualification question.</p>
<b>(USF) Augment</b>	<p>Select this check box if the points for this criteria are considered augmentation points. The points associated with the screening requirement are shown in the Augmentation Points category on the Screening Details page</p> <p>For example, if you award 10 points for full time, 10 points for regular, and you mark the Augment check box for the full time, an applicant who meets both the full time and regular criteria is awarded 10 points for regular, no points for full time, and 10 augmentation points.</p>
<b>(USF) Selective</b>	<p>Select this check box if the points for this criteria are considered selective factors. The points associated with the screening requirement are shown in the Selective Factor Points category on the Screening Details page.</p>

<b>Field or Control</b>	<b>Description</b>
<b>Points</b>	<p>Enter the number of points the applicant receives if they meet the requirement.</p> <p>For certain types of qualifications, this column is read-only and displays the maximum possible point value as shown on the Define Screening Points page. These qualifications include:</p> <ul style="list-style-type: none"> <li>• Multiple-choice questions: each answer can be associated with a different number of points, and those points can be added together when there is more than one correct answer.</li> <li>• Open-ended questions: the question is associated with a maximum value, but evaluators rate the applicants' answers using any number of points up to the maximum.</li> <li>• Content types such as competencies that provide a rating scale: each rating can be associated with a different number of points, and the applicant is awarded the points for the rating that applies.</li> </ul> <hr/> <p><b>Note:</b> All qualifications that you use during screening should be associated with points. The system ignores any selected items which do not have points, and if you leave the page and come back, you will see that the Use in Screening check box has been deselected for any criteria that does not have points.</p>
<b>Total Screening Points</b>	<p>Displays the maximum possible points for the screening level based on the entered scores, including points for all correct answers to questions, and the highest possible score for rated qualifications.</p>

## Define Screening Points Page (Rating Scale Points)

Use the Define Screening Points page for a rating scale (HRS\_JO\_SCR\_RTG\_SEC) to review and override point values for each ratings on the scale.

Navigation:

In the **Screening Requirements** group box in the Job Opening - Screening Criteria page, click the **Edit Details** link for an item that is associated with a rating scale.

This example illustrates the Define Screening Points page for a rating scale.

### Define Screening Points

**Competencies**

Competency    Rehabilitation  
 Description    Self - Proficiency

**Define Points**

Description	Points
0-None	<input type="text" value="0"/>
1-Little	<input type="text" value="1"/>
2-Fair	<input type="text" value="2"/>
3-Good	<input type="text" value="3"/>
4-Very Good	<input type="text" value="4"/>
5-Expert	<input type="text" value="5"/>

For content types that use rating scales, review and optionally override the default points that are awarded for specific ratings.

## Define Screening Points Page (Points for Questions)

Use the Define Screening Points page for questions (HRS\_JO\_SCR\_QSN\_SEC) to review and override point values for multiple-choice and open-ended questions.

Navigation:

In the **Screening Requirements** group box in the Job Opening - Screening Criteria page, click the **Edit Details** link for a multiple choice question or the **Open Ended** link for an open-ended question.

This example illustrates the Define Screening Points page for a single-choice question.

### Define Screening Points

**Question Details**

**Question** Do you have over 2 years of Clinical evaluation experience?  
**Question Type** Single Choice

**Question Points**

Long Description	Points	Correct Answer
Yes	<input type="text" value="10"/>	Y
No	<input type="text" value="0"/>	N

This example illustrates the Define Screening Points page for an open-ended question.

### Define Screening Points

**Question Details**

**Question** Describe the process for making a cup of coffee. Your answer should not exceed 500 words.  
**Question Type** Open Ended

**Question Points**

Points
<input type="text" value="100"/>

For open-ended questions, review and optionally override the maximum point value for the question.



For other questions, review and optionally override the default point value for both correct and incorrect answers.

## View Text ID Text Message Page

Use the View Text ID Text Message page (HRS\_JO\_SCR\_VW\_SEC) to view the complete text of the explanatory message, pass message, or fail message that you selected for prescreening or online screening.

Navigation:

Click the **View Explanatory Message**, **View Pass Message**, or **View Fail Message** link on the Job Opening - Screening Criteria page.

This example illustrates the View Text ID Text Message Page.

### View Text ID Text Message

HRAM\_CEONLEMSG\_01

**Links**

We will assess your application to determine whether your application meets our minimum requirements for acceptance before we review it further. We will advise you of this outcome after you submit your application.

Please note that this assessment establishes your basic eligibility to apply for this position and any false information or misstatement will render your application ineligible.



**Return**

The Text Catalog ID appears above a group box with the full text of the text catalog entry.

---

## Creating Job Postings

This topic discusses how to define job posting and post it to selected posting destinations.

### Pages Used to Create Job Postings

<i>Page Name</i>	<i>Definition Name</i>	<i>Usage</i>
<u>Job Opening Page: Job Postings Section</u>	HRS_JOB_OPENING	Enter job opening data, including job postings.
<u>Posting Information Page</u>	HRS_JO_PST_DTL_SEC	Add job posting details.

<b>Page Name</b>	<b>Definition Name</b>	<b>Usage</b>
<a href="#">Job Description Page</a>	HRS_JOB_DTL_PRVW	Preview a formatted job posting in its entirety.

### Related Links

[Setting Up the Job Posting Description Library](#)

[Managing External Job Postings](#)

## Job Opening Page: Job Postings Section

Use the Job Postings section on the Job Opening page (HRS\_JOB\_OPENING) to review, add, and delete job postings.

---

**Note:** The job opening template controls the display of this section.

---

Navigation:

- **Recruiting > Create Job Opening**

Select **Continue** on the Primary Job Opening page.

- **Recruiting > Search Job Openings**

Select a job opening link in the search results. Under the Job Details tab, select the link for the type of job opening data you want to access.

This example illustrates the Job Opening page: Job Postings section.

**Job Opening**

Save and Open Save as Draft | [Recruiting Home](#) | [Notification](#) | [Start Over](#)

<b>Job Opening ID</b> NEW <b>Job Posting Title</b> Management - Staff Assistant <b>Job Code</b> 170030 (Assistant-Management Staff) <b>Position Number</b> 19000005 (Management - Staff Assistant) <b>Primary Recruiting Location</b> 35 (Delaware Operations) <b>Remove Date</b> 31/03/2024	<b>Status</b> 005 Draft <b>Business Unit</b> GBIBU (Global Business Institute BU) <b>Department</b> 13000 (Finance and Administration) <b>Job Family</b> KADMIN (Administrative Support) <b>Post Date</b> 06/03/2024 <b>Next Review Date</b> 20/03/2024
---	--

Job Details
Qualifications
Screening
Job Postings
Hiring Team

**Job Postings** ⓘ

Postings	Primary Posting Title	
Management - Staff Assistant	<input checked="" type="checkbox"/>	

Add Job Posting

<b>Field or Control</b>	<b>Description</b>
<b>Postings</b>	Displays the posting title for the job posting. Select to open the Posting Information page, where you define posting information.
<b>(USF) Vacancy Announcement Number</b>	Displays the posting identifier used in US Federal implementations. Enter the vacancy announcement number in the <b>VA Number</b> field on the Posting Information page.
<b>Primary Posting Title</b>	Select to use the selected posting title as the primary posting title for the job opening. The system uses the primary posting title to identify the job opening on various pages throughout the system.
	Select to remove a job posting.
<b>Add Job Posting</b>	Select to open the <u>Posting Information Page</u> and add job postings.

## Posting Information Page

Use the Posting Information page (HRS\_JO\_PST\_DTL\_SEC) to add job posting details.

Navigation:

Select an existing job posting or select **Add Job Posting** on the Job Opening Page: Job Postings Section.

The following example illustrates the Posting Information page when configured to modify the posting description directly on the page.

**Posting Information** Help

---

Job Postings ⌵

\*Posting Title:

---

Job Descriptions ⌵ 1 of 1

\*Description Type: Responsibilities ▾      Template: ▾

\*Visibility: Internal and External ▾

The responsibilities of Management Staff Assistant includes:

- Administrative Support:** Management staff assistants often provide administrative support to higher-level management. This can include tasks such as scheduling meetings, managing calendars, handling correspondence, and maintaining files and records.
- Communications Liaison:** They serve as a liaison between management and other employees or external parties. This involves relaying messages, coordinating communication, and ensuring that information flows smoothly within the organization.
- Project Coordination:** Management staff assistants may assist in coordinating various projects or initiatives within the organization. This can involve tasks such as organizing meetings, tracking progress, and ensuring that deadlines are met.
- Research and Analysis:** They may conduct research and analysis on behalf of management, gathering information, compiling reports, and providing insights to support decision-making processes.
- Event Planning:** Management staff assistants may be responsible for planning and coordinating events such as conferences, workshops, or corporate functions. This can involve arranging logistics, coordinating with vendors, and managing attendee registration.

---

Job Posting Destinations ⌵

Primary Posting Destination	Destination	Posting Type	Relative Open Date	Post Date	Remove Date	Posting Duration (Days)	Next Review Date	Days Till Next Review
<input checked="" type="checkbox"/>	Internet	Internal Posting	0 - On Approva	26/03/2024	30/04/2024	<input type="text" value="35"/>	15/04/2024 <span style="font-size: x-small;">⌵</span>	<input type="text" value="20"/>
<input type="checkbox"/>	Internet	External Posting	0 - On Approva	26/03/2024	20/04/2024	<input type="text" value="25"/>	10/04/2024 <span style="font-size: x-small;">⌵</span>	<input type="text" value="15"/>

The following example illustrates the Posting Information page when configured to modify the posting description in a modal window.

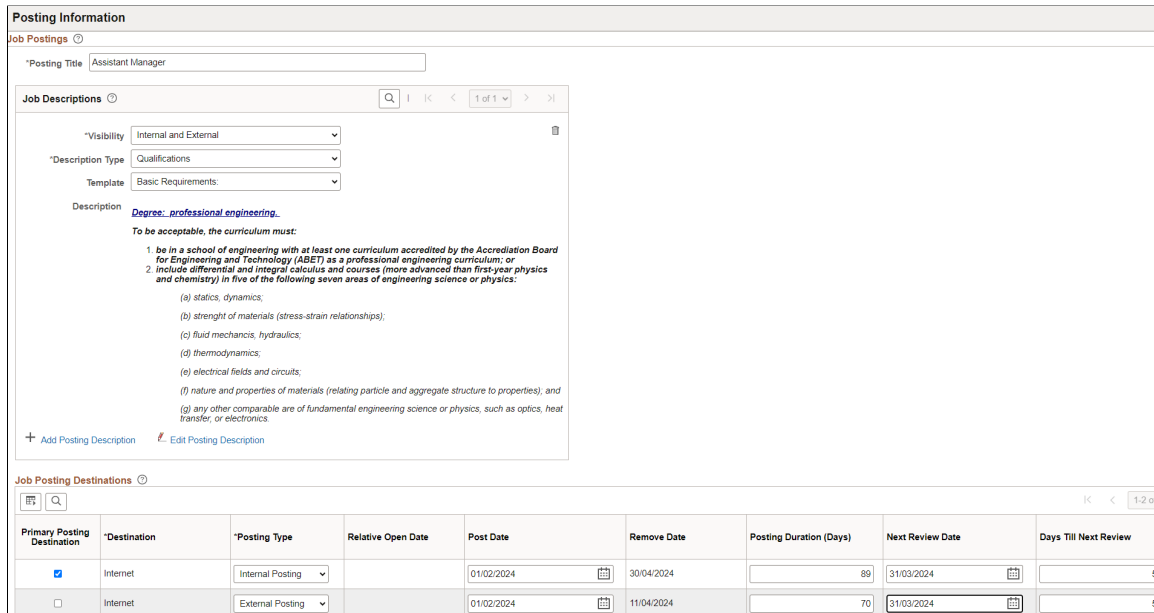

## Job Postings

Field or Control	Description
Posting Title	Enter the title for the posting. The default value is the primary posting title for the job opening.

## (USF) Federal Information

Use the fields in this group box to meet the posting requirements for U.S. federal job openings if third-party integration has been set up.

## Job Descriptions

Use the Job Descriptions fields to create the applicant-facing job description for the job posting. The posting description includes one or more sections with formatted text and images. Each section is marked as visible to internal applicants, external applicants, or both. When the system posts the description electronically, the appropriate sections are concatenated based on whether the posting is for internal or external applicants. To configure how you enter the posting description, see [Recruiting Installation – Jobs Page](#).

Field or Control	Description
Visibility	Specify whether to include this section of the posting description in <i>Internal</i> postings, <i>External</i> postings, or both <i>Internal and External</i> postings.

<i>Field or Control</i>	<i>Description</i>
<b>Description Type</b>	Select a job posting description type. These are predefined categories of information to include in posting descriptions. The available choices come from the job posting template that is linked to the recruitment template.  See <a href="#">Setting Up the Job Posting Description Library</a> .
<b>Description ID</b>	Select a job posting description ID. These are predefined categories of information to include in posting descriptions.
<b>Template</b>	Optionally select a template to provide boilerplate for the specified description type.
<b>&lt;Posting Content&gt;</b>	Enter content for this section of the posting description. If you selected a template, the boilerplate appears here, but you can modify it as needed.  Use the associated formatting, image, and spell-check tools to enhance the design of your posting description.
<b>Add Posting Description and Delete Posting Description</b>	Click to add sections to the posting description or remove sections from the posting description.
<b>Edit Posting Description</b>	Select to modify the posting description in a modal window with Rich Text Editor. Ideal if you have large number of posting descriptions. This option is available based on the setup in the <a href="#">Recruiting Installation – Jobs Page</a> .
	Click to remove the posting description. This option is available based on the setup in the <a href="#">Recruiting Installation – Jobs Page</a> .

### Job Posting Destinations

<i>Field or Control</i>	<i>Description</i>
<b>Primary Posting Destination</b>	Select to display the <b>Post Date</b> , <b>Remove Date</b> , and <b>Next Review Date</b> in the header of the job opening page. See <a href="#">Job Opening Page</a> .  <b>Note:</b> The posting destination details are displayed in the job opening header only if it has a job posting marked as primary, and the job posting has a primary job posting destination.

<b>Field or Control</b>	<b>Description</b>
<b>Destination</b>	<p>Select the recruitment source where you are sending this posting. Three types of recruitment sources are available for selection:</p> <ul style="list-style-type: none"> <li>• <i>Company</i> recruitment sources represent your organization's own job sites. The job posting appears on the sites that are associated with the recruitment source.</li> <li>• <i>Vendor</i> recruitment sources represent third-parties such as job boards or service procurement providers. A posting that includes a vendor recruitment source is available to be sent to the vendor using the Open Integration Framework. The system does not send the posting automatically, however. Instead, the posting appears on the <a href="#">Manage External Postings Page</a>, where users can post, unpost, and update specific job postings.</li> <li>• <i>Marketing</i> recruitment sources are places where you advertise job openings. Examples might include internet or email advertisements, print advertisements, and job fairs. There is no integration with marketing sources, so including a marketing source as a posting destination is informational only. Marketing recruitment sources include a setting to control whether they appear in the list of posting destinations.</li> </ul> <p>See <a href="#">Setting Up Recruitment Sources</a>.</p>

<b>Field or Control</b>	<b>Description</b>
<b>Posting Type</b>	<p>Select the type of posting.</p> <p>To make postings available on Candidate Gateway sites, you must select one of these values:</p> <ul style="list-style-type: none"> <li>• <i>External</i></li> </ul> <p>In PeopleSoft Candidate Gateway, these are the only job postings that external applicants can see. The posting description does not include any sections marked as internal.</p> <ul style="list-style-type: none"> <li>• <i>Internal</i></li> </ul> <p>In PeopleSoft Candidate Gateway, these are the only job postings that internal applicants can see. The posting description does not include any sections marked as external.</p> <p>Postings to third-party job boards are identified by the destination (a vendor) without regard for the posting type, but you still use the <i>External</i> and <i>Internal</i> posting types to determine which sections of the posting description apply to the posting.</p> <p>The remaining values are informational only. Use them for postings to non-electronic posting destinations. These values are:</p> <ul style="list-style-type: none"> <li>• <i>Contingent</i></li> <li>• <i>Office</i></li> <li>• <i>Recruitment</i></li> </ul>
<b>Relative Open Date</b>	<p>Choose how far in the future you want the job posting posted to this destination. If you select a value in this field, the system calculates the posting date and displays it in the <b>Post Date</b> field, which becomes unavailable for entry.</p> <p>For example, if the date the job opening reaches the status of <i>Open</i> is September 5, 2009 and you select <i>Ten Days</i> as the relative open date, the <b>Post Date</b> will be September 15, 2009.</p>
<b>Post Date</b>	<p>Enter the date on which you want the job posting posted to this destination.</p>

<b>Field or Control</b>	<b>Description</b>
<b>Remove Date and Posting Duration (Days)</b>	Either enter a specific date on which you want to remove the posting from this destination, or enter the number of days that the posting is to remain active. If you enter a posting duration, the system calculates the removal date and displays it in the <b>Remove Date</b> field, which becomes unavailable for entry.
<b>Next Review Date and Days Till Next Review</b>	Enter a date when the application for the selected job posting destination is reviewed. The system automatically populates the value for <b>Days Till Next Review</b> . If you enter a duration for <i>Days Till Next Review</i> , then the system calculates and displays it in the <i>Next Review Date</i> field.  <b>Note:</b> The next review date must be between the post date and remove date for the selected job posting destination.
	Select to remove the job posting destination.

**Preview**

<b>Field or Control</b>	<b>Description</b>
<b>Preview</b>	Click this button to access the Job Description page, where you can review the complete formatted job posting.

See [Setting Up the Job Posting Description Library](#).

**Related Links**

[Setting Up the Job Posting Description Library](#)

[Managing External Job Postings](#)

**Job Description Page**

Use the Job Description page (HRS\_JOB\_DTL\_PRVW) to preview a formatted job posting in its entirety.

Navigation:

Click the **Preview** button on the Posting Information page.



This example illustrates the Job Description Page.

## Job Description

**Job Title** Bring Your Arbitration Experience to Labor Relations

**Job ID** 503708

**Location** Delaware Operations

**Full/Part Time** Full-Time

**Regular/Temporary** Regular

---

[Return to Previous Page](#)                      [Switch to Internal View](#)

---

**Qualifications**

### Global Business Institute (GBI)

---

#### *Senior Legal Adviser*

*GBI has agreed on voluntary arbitration procedures with its Labor stakeholders.*

*This has been done in the interests of disruption free work environments by ensuring that all referred cases are fairly and expeditiously resolved by independent third parties.*

*This role requires someone with extensive arbitration experience. The incumbent would report to the Divisional Manager Human Resources and be responsible for running the newly established Arbitration Section. All new agreements must be implemented and all Company policies reviewed and updated to include the current situation,*

*All arbitration briefs, costs and proceedings will be managed with provision of meaningful statistical indicators to drive down unnecessary use of third party services.*

*GBIBU is an employer of choice and we have a wide variety of benefits which can be efficiently structured to suit your individual requirements. GBI has an unequalled reputation for providing challenging work situations and merit bonuses for top performers.*

---

*If this is a role that would suit your profile why not apply on-line now?*

---

[Return to Previous Page](#)                      [Switch to Internal View](#)

---

<b>Field or Control</b>	<b>Description</b>
<b>Switch to Internal View</b> and <b>Switch to External View</b>	Use these links to switch the preview between internal applicant mode and external applicant mode. In each mode, individual sections of the posting are included based on whether they have been marked as internal, external, or both.

## Identifying Recruiting Team Members for a Job Opening

This topic provides an overview of recruiting teams and discusses how to identify recruiting team members.

### Pages Used to Identify Recruiting Team Members for a Job Opening

<i>Page Name</i>	<i>Definition Name</i>	<i>Usage</i>
<a href="#">Teams Page</a>	HRS_TEAM	Create and maintain teams that can be added to job openings.
<a href="#">Job Opening Page: Assignments Sections</a>	HRS_JOB_OPENING	Enter job opening data, including members of the hiring team.
<a href="#">Add Team Page</a>	HRS_TEAM_ADD_SEC	Identify a team whose members are to be added to the job opening hiring team.

## Understanding Recruiting Teams

When you create a job opening, you identify the recruiters, hiring managers, interviewers, interested parties, and screening team members for the job opening.

You can set up predefined teams whose members can be added to the job opening all at once. If groups of people typically work together on the same job openings, creating and adding teams can be faster than adding each team member individually to each job opening.

When a team is added to the job opening, the system does not add the actual team ID to the job opening. Instead, users who currently belong to the team are added individually to the job opening.

Only active teams can be added to a job opening.

There is no limit to the number of teams you create, nor to the number of teams to which an employee can belong.

## Teams Page

Use the Teams page (HRS\_TEAM) to create and maintain teams that can be added to job openings.

Navigation:

**Recruiting > Administration > Hiring Teams**

This example illustrates the Teams page.

### Teams

**Teams**

Team ID

\*Status

\*Description

Short Description

**Members**

*Empl ID	*Name		
<input type="text" value="KU0105"/>	<input type="text" value="Vicky Adler"/>	<input type="button" value="+"/>	<input type="button" value="-"/>
<input type="text" value="KU0106"/>	<input type="text" value="Kevin Chae"/>	<input type="button" value="+"/>	<input type="button" value="-"/>
<input type="text" value="KU0108"/>	<input type="text" value="Joyce Hayden"/>	<input type="button" value="+"/>	<input type="button" value="-"/>

<i>Field or Control</i>	<i>Description</i>
<b>Team ID</b>	Displays the team’s unique identifier.
<b>Status</b>	Specify whether this team is <i>Active</i> or <i>Inactive</i> .
<b>Empl ID</b>	Select the employee IDs for the members of this team.

## Job Opening Page: Assignments Sections

Use the sections in the Assignments group box on the Job Opening page (HRS\_JOB\_OPENING) to select recruiters, hiring managers, and other members of the hiring team.

---

**Note:** The template for the job opening controls whether this section appears and, if so, where it appears.

---

Navigation:

- **Recruiting > Create Job Opening**

Click the **Continue** button on the Primary Job Opening page and, if necessary, on the Combined Profile Information page.

- **Recruiting > Search Job Openings**

Click the link for a job opening in the search results, then click the Job Details tab, then click the link for the type of job opening data you want to access.

This example illustrates the five assignment-related sections on the Job Opening page.

**Assignments** ?

**Recruiters** ?

Name	Recruiter ID	Primary	
Jake Oglevy	N00004	<input checked="" type="checkbox"/>	
Vicky Adler	KU0105	<input type="checkbox"/>	

Add Recruiter
Add Recruiter Team

**Hiring Managers** ?

Name	Manager ID	Primary	
Ponciano Batalang	N00002	<input checked="" type="checkbox"/>	

Add Hiring Manager
Add Hiring Manager Team

**Interviewers** ?

Name	Interviewer ID		
Betty Locherty	KU0007		

Add Interviewer
Add Interviewer Team

**Interested Parties** ?

Name	Empl ID		
Douglas Lewis	KU0001		

Add Interested Party
Add Interested Parties Team

**Screening Team** ?

No Screening Team has been added to this Job Opening

Add Screening Team Member
Add Screening Team

### Common Elements for Hiring Team Members

<b>Field or Control</b>	<b>Description</b>
<b>Name</b>	<p>Enter the name of the person that you want to add to one of the hiring team groups. The system displays the person's employee ID in the adjacent field.</p> <p>All members of the hiring team have access to the job opening, regardless of the person's specific role on the hiring team.</p>
<b>&lt;Team Member Type&gt; ID</b>	Displays the employee ID of the team member. The label changes depending on the grid (for example, Recruiter ID or Manager ID), but the field always displays the employee ID.
<b>Add &lt;grid name&gt;</b>	Click to add another row to the grid.

<b>Field or Control</b>	<b>Description</b>
<b>Add &lt;grid name&gt; Team</b>	<p>Click to access the Add Team page, where you select a team whose members are added to the grid.</p> <p>When you add a team to the Recruiters grid, only team members who are associated with a the <i>Recruiter</i> recruiting role type are added.</p> <p>When you add a team to the Hiring Managers grid, only team members who are associated with the <i>Hiring Manager</i> recruiting role type are added.</p> <p>When you add a team to any other grid, all team members are added.</p>

## Recruiters

Use this group box to identify recruiters for this job opening. Only users who are associated with the *Recruiter* recruiting role type can be added to the hiring team as recruiters.

See [Understanding Recruiting Security](#).

If job opening approvals are active, the delivered approval process allows any recruiter assigned to the job opening to provide final approval.

<b>Field or Control</b>	<b>Description</b>
<b>Primary</b>	<p>Select this check box to identify the primary recruiter for this job opening.</p> <p>When searching for job openings based on your association with the job, you are considered to be "assigned to" the job opening if you are the primary recruiter; non-primary recruiters are considered to be "associated with" the job opening.</p> <p>The primary recruiter receives any offer-related notifications that an applicant submits through Candidate Gateway.</p>

## Hiring Managers

Use this group box to identify hiring managers for this job opening. Only users who are associated with the *Hiring Manager* recruiting role type can be added to the hiring team as hiring managers.

<b>Field or Control</b>	<b>Description</b>
<b>Primary</b>	<p>Select this check box to identify the primary hiring manager for this job opening.</p> <p>When searching for job openings based on your association with the job, you are considered to be "assigned to" the job opening if you are the primary hiring manager; non-primary hiring managers are considered to be "associated with" the job opening.</p> <p>If job opening approvals are active, the primary hiring manager is treated as the approval requester, and the delivered approval process uses the primary hiring manager's supervisor as the first approver.</p>

### **Interviewers**

Use this group box to identify interviewers for this job opening.

The system uses this list of interviewers to provide default interviewers when you set up an interview schedule for this job opening. Additionally, the interviewers listed in this grid have security access to the job opening. You can add additional interviewers to the interview schedule, but doing so does not enable those interviewers to access the job opening using the Search Job Openings page.

### **Interested Party**

Use this group box to identify interested parties for this job opening. Other than having access to the job opening, interested parties have no specific privileges, nor do they receive any notifications.

### **Screening Team**

Use this group box to identify members of the screening team for this job opening. Other than having access to the job opening, screening team members have no specific privileges, nor do they receive any notifications.

## **Add Team Page**

Use the Add Team page (HRS\_TEAM\_ADD\_SEC) to identify a team whose members are to be added to the job opening hiring team.

Navigation:

Click the **Add <team type> Team** link for any of the [Job Opening Page: Assignments Sections](#)

This example illustrates the Add Team page.

**Add Team**

Team	Team ID	Description
<input type="checkbox"/>	101	BAT Recruiters Team
<input type="checkbox"/>	1000	Recruiters
<input type="checkbox"/>	1001	Hiring Managers
<input type="checkbox"/>	1002	Management
<input type="checkbox"/>	1004	Approver / Interviewer Team

<i>Field or Control</i>	<i>Description</i>
<b>Select</b>	Select this check box for one or more teams whose members are to be added to the job opening hiring team.
<b>OK</b>	Click to add the selected teams to the job opening.

## Cloning Job Openings

This topic provides an overview job opening cloning and discusses how to clone a job opening.

### Page Used to Clone Job Openings

<i>Page Name</i>	<i>Definition Name</i>	<i>Usage</i>
<u>Clone Job Opening Page</u>	HRS_JO_CLONE_SEC	Clone a job opening.

### Understanding Job Opening Cloning

When creating a job opening that is similar to an existing one, you can avoid tedious data entry by cloning the existing job. You can clone existing job openings that have any status except *Draft*.

To clone a job opening, access the job opening that you want to clone and click the Clone toolbar button. Before you complete the clone action, verify the number of new clones to be created (the default is 1) and the job posting description to be used for the new clones (the default is the same description as the original job opening).

## StatUSES of New Clones

If approvals are required, the system puts the new job openings in *Draft* status. This is the same status that is applied if you created a new job opening manually and click the Save as Draft button. The specific status is based on your configurable status settings, where you mark one job opening status as your draft status.

If approvals are not required (as configured on the [Recruiting Installation - General Page](#)), users can choose whether to put the new job openings in Draft status or in Open status. The open status is the one designated as the default job opening status in your configurable status settings. This is the same status that is applied when a job opening is approved or, if approvals are not active, when the job opening is opened.

In general, if the user intends to review and modify the new job opening, the best practice is to put it in draft status. However, even if the new job opening is in the Open status, posting information (**Relative Open Date, Post Date, and Remove Date**) are not copied, so the job is not posted to Candidate Gateway or other job posting sites.

## Data That Is Not Copied During Cloning

When you clone a job opening most of the data is copied from the existing job opening to the new one, including profile-related qualifications and screening criteria. However, some data will be left blank or adjusted, as detailed in this table:

<b>Original Job Opening</b>	<b>Adjusted Data in the New Job Opening</b>
Created By	The person who created the new job opening using the cloning process.
Created (the created date)	The date that the new job opening is created.
Status Code	<i>Draft</i> if approvals are required. Otherwise, the user who creates the new job opening chooses whether to put it in <i>Draft</i> status or <i>Open</i> status.
Status Reason	The first reason associated with the new status code.
Status Date	The date that the new job opening is created.
Desired Start Date	Blank
Projected Fill Date	Blank
Date Authorized	Blank if the new job opening is created in <i>Draft</i> status.  The current date if the job opening is created in <i>Open</i> status.



<b>Original Job Opening</b>	<b>Adjusted Data in the New Job Opening</b>
Begin Date and End Date	Blank
Posting dates	Not copied.
Hiring team	Active team members copied.  If the primary recruiter or hiring manager is no longer active, but other recruiters or hiring managers are, the new job opening will have only non-primary recruiters or hiring managers. When you access the new job opening and attempt to save it, the system will display a message that one recruiter or hiring manager must be designated primary.
Approval process, if one exists	Not copied.
Notes and attachments	The notes and attachments are copied, but the dates for both are the date that the new job opening is created.
Applicants and all applicant-related data	Not copied.
Category	Not copied (new job opening has no category).

**Note:** When you clone a job opening, the salary range data is *not* adjusted. It is copied from the original job opening into the newly created clone. The system does not fetch current salary ranges from the job code table.

## Access to Cloning Functionality

Users with PeopleTools roles that are associated with a recruiting role type have access to cloning functionality. A proxy approver who does not have a recruiting role type cannot clone the job opening. The proxy approver receives access to the job opening through the delegation process, but the Clone button is hidden.

See [Understanding Recruiting Security](#).

## Clone Job Opening Page

Use the Clone Job Opening page (HRS\_JO\_CLONE\_SEC) to clone a job opening.

Navigation:

Click the **Clone** toolbar button on the Manage Job Opening page.

This example illustrates the Clone Job Opening page before you complete the cloning process.

The screenshot shows a window titled "Clone Job Opening" with a close button in the top right corner. The content includes:

- Job Opening ID: 300269
- Posting Title: Senior Manager-Finance
- \*New Posting Title: Senior Manager-Finance (text input field)
- \*Number of New Job Openings: 3 (text input field)
- New Job Opening Status:  Draft  Open
- Buttons: Clone, Cancel

**Note:** If there are inactive questions in Screening Questions section under Manage Job Opening, Qualification tab, then the user is prompted whether to cloning the inactive questions as well.

<b>Field or Control</b>	<b>Description</b>
<b>Job Opening ID and Posting Title</b>	These fields display identifying information about the job opening that you are cloning.
<b>New Posting Title</b>	Enter a posting title for the new job openings that the clone process creates. The default value is the posting title of the original job opening.
<b>Number of New Job Openings</b>	Enter the number of job openings that you want to create. The default value is 1.
<b>New Job Opening Status</b>	Choose the initial status for the newly created clones. Select <b>Draft</b> to assign the status that is designated as the draft status for job openings. Select <b>Open</b> to assign the status that is designated as the default status for job openings.  <b>Note:</b> If job opening approvals are active, this field does not appear, and all new clones are created in a draft status.
<b>Clone</b>	Click to clone the job opening. The system creates the new job openings and updates the page with a confirmation message and a list of newly created job openings.

This example illustrates the Clone Job Opening page after you complete the cloning process. Fields that were editable before you clicked the **Clone** button are now read-only.

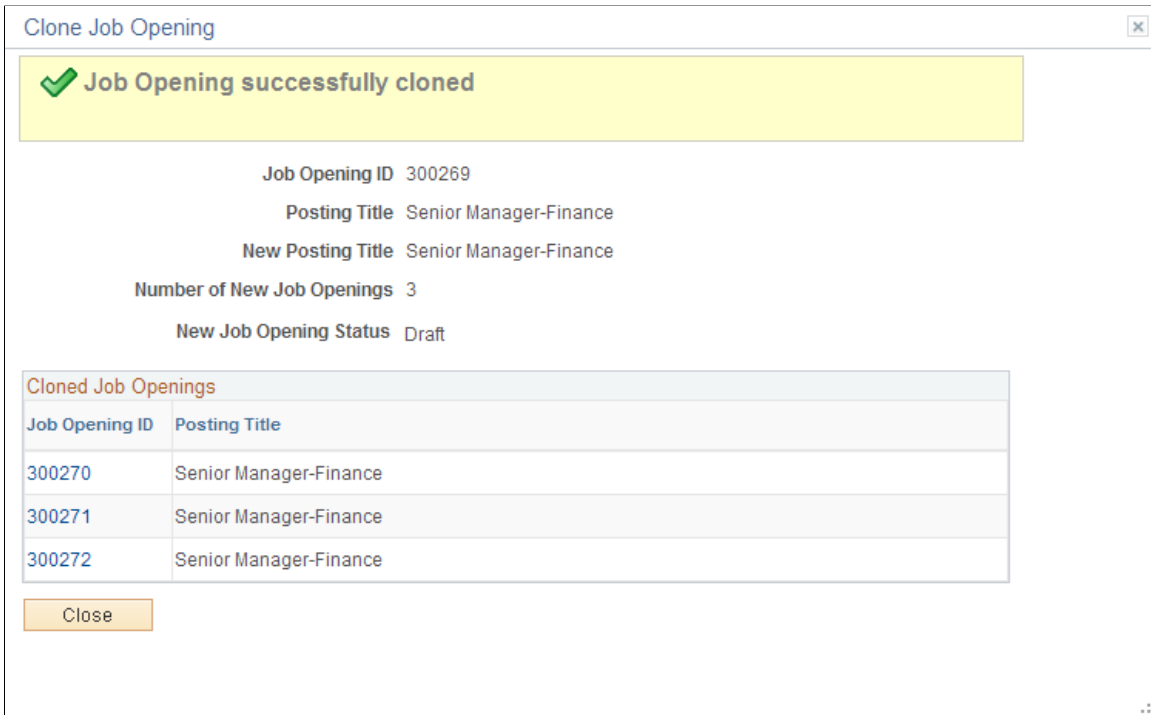

<b>Field or Control</b>	<b>Description</b>
<b>Cloned Job Openings</b>	<p>This grid lists the newly created job openings. Each job opening has a unique Job Opening ID, but the posting title is the same for all of them.</p> <p>Click a Job Opening ID to access a newly created job opening. If you created one clone, the job opening opens in the current window, and the confirmation message disappears permanently.</p> <p>If you created multiple clones, the job opening opens in a new window so that you can easily return to the confirmation message and access another newly created clone.</p>

## Creating Job Openings from Open Positions

This topic provides an overview of the create Job from Position process and discusses how to create job openings from open positions.

## Page Used to Create Job Openings from Positions

<i>Page Name</i>	<i>Definition Name</i>	<i>Usage</i>
<u>Create Job Openings from Positions Page</u>	HRS_RUN_CR_JOB	Create job openings from open positions.

## Understanding the Create Job from Position Process

To create job openings from open positions, run the Create Job from Position Application Engine process (HRS\_CRJOB).

---

**Note:** This feature is available only to organizations that use partial or full position management.

---

During the Create Job from Position process, the system:

1. Determines all current open positions in the company.

To determine whether a position is open, the system uses the PS\_POSN\_VACANT view on the Position Data table (PS\_POSITION\_DATA).

2. Identifies the maximum head count allowed for each open position.
3. Determines the current head count for each open position (how many incumbents, or current employees, fill any or all of the head count).
4. Creates one standard requisition job opening for each position number that has openings and sets the status of each new job opening to Draft.

When the system creates a new job opening, it populates the job opening data with data from the position or the derived job code—for example, the business unit, job code, company, department, location, and staffing and salary information. The system also populates the **Target Openings** field on the Job Opening page with the number of openings (maximum head count minus current head count) for that position number.

If you select the **Allow Duplicates** check box on the Create Job Openings from Positions page, the system creates a job opening for all open positions, regardless of whether a job opening for a position already exists.

If you deselect the **Allow Duplicates** check box on the Create Job Openings from Positions page, the system checks to see if a job opening already exists for each position number. If a job opening already exists for a position number, the system creates a new job opening only if the number of open positions (maximum head count minus current head count) is greater than the number of target openings on the Job Opening page for the existing job opening. For example, if a position has five openings and a job opening already exists for that position with a target opening value of two, the system creates one new job opening with three as the target opening value.

The system uses the position data along with the segmenting type that is specified in the **Template Segmenting Type** field on the Recruiting Installation - General page to select a recruitment template for each job opening. Because position data can be different for each position, the system could potentially use a different recruitment template for each job opening that it creates.

When you run the process, you must specify an originator. The originator appears in the **Created By** field on the Job Opening page, and will have access to the job openings after the system creates them. After the process completes, the originator will be able to access the new job openings through existing recruiting components, complete the necessary data entry—for example, screening, posting, and approval information—and submit the job opening for approval or save as normal, depending on whether the system requires approval for standard requisitions job openings.

---

**Note:** The user must also have the HCCPRS0000 permission list to access the page where you run the Create Job from Position process.

---

See [Delivered Permission Lists and Roles](#).

## Create Job Openings from Positions Page

Use the Create Job Openings from Positions page (HRS\_RUN\_CR\_JOB) to create job openings from open positions.

Navigation:

**Recruiting > Administration > Create Openings from Positions**

This example illustrates the Create Job Openings from Positions page.

<b>Field or Control</b>	<b>Description</b>
<b>Allow Duplicates</b>	Select to have the system create job openings for all position openings, regardless of whether a job opening already exists for a position. Deselect this option if you do not want the system to create duplicate job openings. By default, this option is deselected.
<b>Originator</b>	Select the ID of the person that you want to be the originator of the new job openings. The originator appears in the <b>Created By</b> field on the Job Opening page, and will have access to the job openings after the system creates them. By default, the system populates this field with the current user's ID.
<b>Run</b>	Click to access the Process Scheduler Request page, where you initiate the process.

## Approving Job Openings

This topic provides overviews of setup for job opening approvals, how to approve job openings, and the delivered approval process for job openings.

This topic then discusses how to approve job openings using classic approval pages or Fluid Approvals.

### Pages Used to Approve Job Openings

<i>Page Name</i>	<i>Definition Name</i>	<i>Usage</i>
<u>Pending Approvals Page</u>	HRS_RECRUIT_CONSOL	View pending approvals and approve job openings.
<u>Job Opening Page: Approvals Tab</u>	HRS_JOB_OPENING	Approve a job opening or add approvers or reviewers to the approval process.
<u>Insert Additional Approver or Reviewer Page</u>	NA	Add approvers or reviewers to the approval process.
<u>Job Opening Page for Fluid Approvals</u>	EOAWMA_TXNHDTL_FL	Approve a job opening.
<u>Additional Details Page</u>	HRS_JOB_DTLS_SCF	Review additional job opening details.
<u>Posting Destinations Page</u>	HRS_JOPSTDST_SCF	Review posting information for a job opening.

### Understanding Setup for Job Opening Approvals

Job opening approval processes are configured using the common Approval Framework and then activated using a setting on the Recruiting Installation page.

#### Approval Framework

Approval processes are defined using the common Approval Framework. Recruiting Solutions uses the *JobOpening* approval process definition, created in the Approval component (PTAF\_TXN), to manage approval processing for job openings.

For more information, see “Understanding Approvals” (Application Fundamentals) and “Setting Up Approval Process Definitions” (Application Fundamentals).

#### Approval Process Activation

To activate approval processing for job openings, use the check boxes in the **Approvals Required** group box on the Recruiting Installation - General Page. There are separate check boxes for standard requisitions and continuous job openings; select the check boxes for the types of job openings that require approval.

## Understanding How to Approve Job Openings

This overview discusses how to act on a job opening approval request.

### Approval Pages

The following pages are available for approving job openings:

- The [Pending Approvals Page](#) under the Recruiting menu lists the job openings that require your approvals. You can act on one or more approval request directly on this page.

---

**Note:** The Pending Approvals page under the Recruiting menu is a classic page. Fluid Approvals also has a Pending Approvals page that lists pending approvals for all transactions, not just recruiting transactions.

---

- The [Job Opening Page: Approvals Tab](#) enables you to take action on the specific job opening you are viewing.

The notification that the system sends to approvers includes a direct link to the Job Opening page.

- The [Job Opening Page for Fluid Approvals](#) enables you to approve job openings within the common Fluid Approvals component.

For more information about Fluid Approvals, see “Using PeopleSoft Fluid User Interface Self-Service Approval Transactions” (Application Fundamentals).

- Additionally, when a user searches for Pending Approval job openings on the [Search Job Openings Page](#), approvers or recruiting administrators can select one or more pending job openings from the search results and act on the approval request using the Group Action menu.

---

**Important!** If a user other than the assigned approver, that approver's proxy, or a recruiting administrator initiates an approval-related action on the Search Job Openings page, the action will *not* update the job opening.

---

### Approver Actions

Approvers have these options:

- Approving the job opening.

The system records the approval and notifies the next approver, if any. When the final approver approves the job opening, the system sets the job opening status to *Open*.

- Pushing back the job opening.

The system notifies the previous approver that the job opening has been pushed back and needs his or her attention.

Pushing back a job opening takes a currently pending step out of pending status and requeues the previous step to its approvers. The purpose of push back is to question the prior step's approval and request clarification. Because push back only makes sense if there is a previous approver, the first approver cannot push back.

- Denying the job opening.

The system sets the job opening status to *Denied*, stops the approval process, and notifies the requester (the primary hiring manager or, if no hiring managers exist, the creator). The requester can then resubmit the job opening.

- Resubmitting the job opening.

The Resubmit action is available only to the requestor, and it is available only if the job opening is in *Denied* status. When the requestor resubmits the job opening, the system sets the job opening status to *Pending* and the approval process starts over.

---

**Note:** The job opening approval process does not support self-approval. The system treats the primary hiring manager as the requester, regardless of who actually creates the job opening, so even if a job opening is submitted by an approver (for example, the primary hiring manager's supervisor), the system does not recognize that the approver is acting as the requester, and no self-approval processing occurs.

---

## Changes to Job Opening Data During Approval Processing

While the job opening is in the approval process, information on the job opening can be changed. However, changing the data in specific fields before the job opening has reached final approval causes the system to start the approval process over. A notification is sent to the first approver and the approval process begins again.

---

**Note:** Changes to an approved and posted job opening do not have to be approved again.

---

The fields that can cause a trigger to occur are:

- **Target Openings**
- **Job Code**
- **Position Number**
- **Salary Administration Plan**
- **From Salary Grade**
- **To Salary Grade**
- **Full-time/Part-time**
- **Regular/Temporary**
- **Standard Hours**
- **(USF) Recruitment Type**
- **(USF) Area of Consideration**
- **(USF) Salary Range From**
- **(USF) Salary Range To**
- **(USF) Pay Frequency**



- (USF) **Citizenship Status**

## Approval Delegation

If you enable delegation for job opening approval, approvers can delegate approval authority to proxies for specified amounts of time. The system gives the proxy access to the Pending Approvals component, which displays the job openings for which approval has been delegated.

For more information, see [Talent Acquisition Manager Delegations](#).

## Understanding the Delivered Approval Process for Job Openings

If a job opening requires approval, clicking the Save and Submit button initiates the approval process.

### Identifying the Requester

The delivered approval process treats the primary hiring manager as the requester, regardless of who created the job opening and who submitted it for approval. If the job opening does not have any hiring managers on the hiring team, the user who created the job opening is treated as the requester.

The requester receives approval-related notifications and, if the job opening is denied, the requester can resubmit it.

### The Delivered Two-Step Job Opening Approval Process

The delivered approval process for job openings requires two approvers:

1. The first approver is the supervisor of the person or persons entered as the primary hiring manager on the Job Opening page.

To identify the supervisor, the system uses the Target Information page.

2. The second approver is the recruiter or recruiters entered as the recruiter for the job opening.

This is how the delivered two-step job opening approval process works:

1. A user creates a job opening and submits it.

The system sets the job opening status to *Pending Approval*. The system also identifies the first and second approvers and displays the Job Opening - Approval page that summarizes who is in the two-step approval process.

2. The system notifies the first approver.

The first approver is the supervisor of the person entered as the primary hiring manager on the Job Opening page. If there are no hiring managers, then the first approval step is skipped. To identify the supervisor of the hiring manager, the system uses the “Target Information Page” (Application Fundamentals).

---

**Note:** If the supervisor of the primary hiring manager is inactive, the system checks the level up to find the supervisor of the inactive employee.

---

See “Setting Up Access to Direct Reports Data” (Application Fundamentals).

- If the first approver approves the job opening, the system notifies the second approver.

The second approver is any recruiter assigned to the job opening.

If there are no recruiters, the system routes the approval request to the Recruiting Solutions Approval Administrator.

- If the second approver approves the job opening, the system updates the status of the job opening to Open and ends the approval process.

This diagram shows the delivered two-step approval process during which two approvers sequentially approve or deny a job opening.

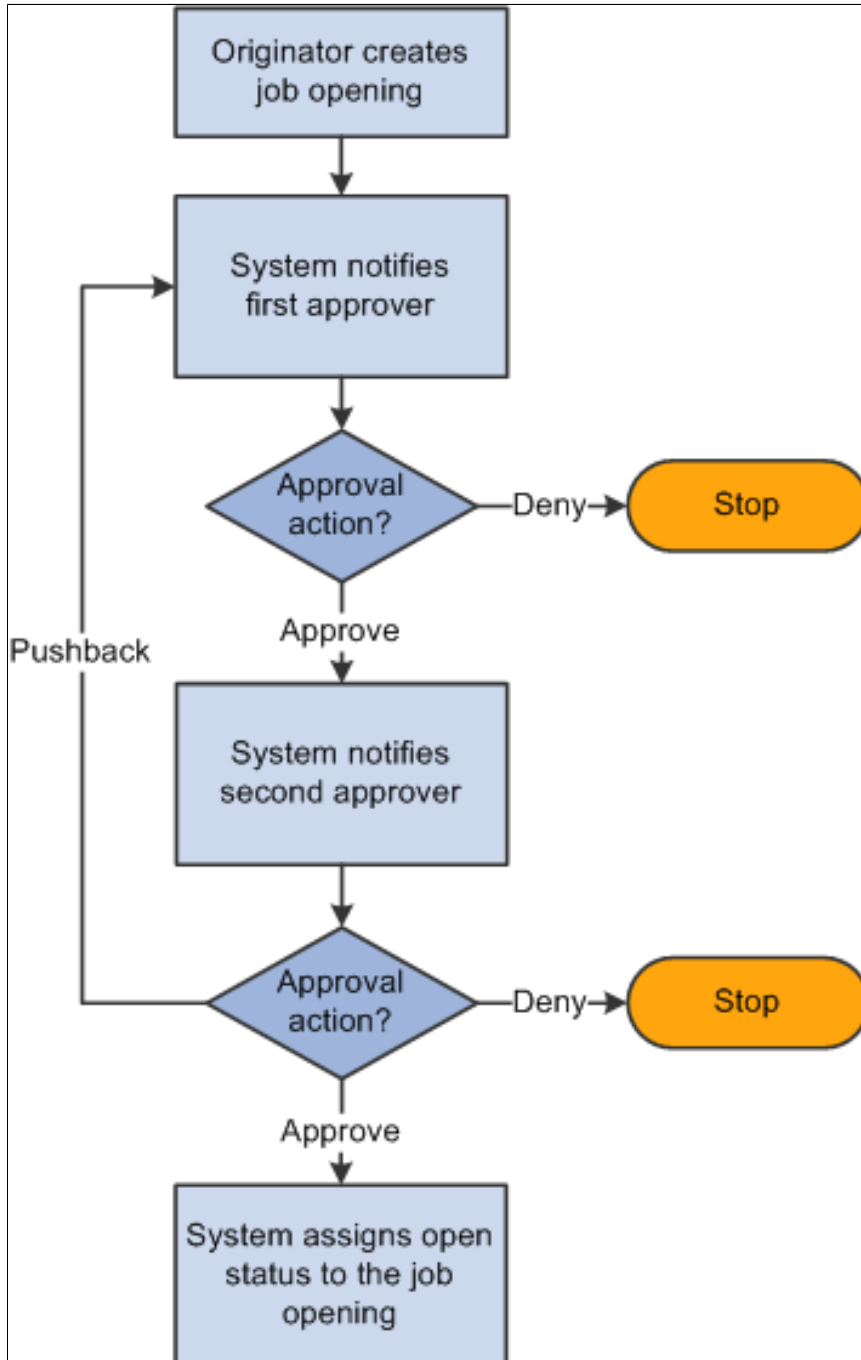

## Pending Approvals Page

Use the Pending Approvals page (HRS\_RECRUIT\_CONSOL) to view and act on pending approval requests.

Navigation:

**Recruiting > Pending Approvals**

This example illustrates the Pending Approvals page.

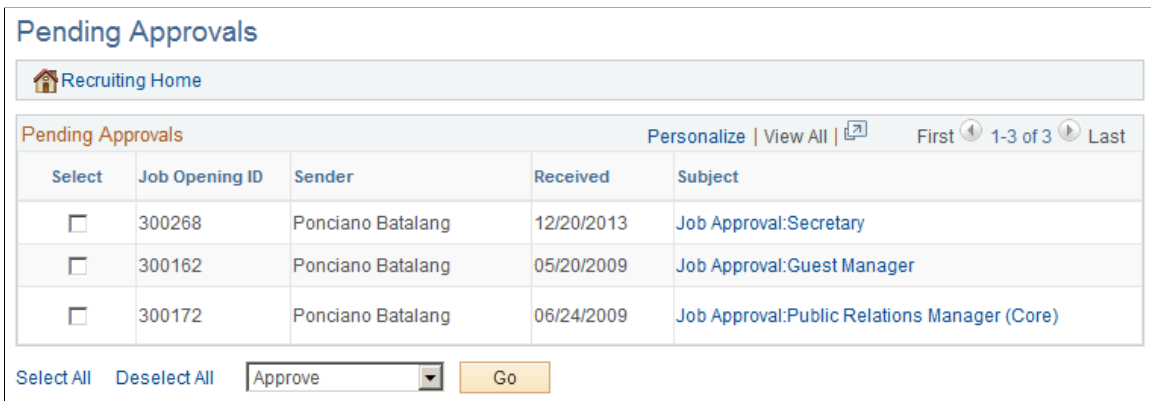

<i>Field or Control</i>	<i>Description</i>
<b>Recruiting Home</b>	Click to access the <a href="#">Recruiting Home Page</a> .

## Pending Approvals

<i>Field or Control</i>	<i>Description</i>
<b>Select</b>	To approve or deny multiple pending approvals, select the check boxes for the transactions that you want to approve or deny,  If a job opening’s approval processing has been turned off in the Recruiting Installation component, the check box for the transaction is disabled and the user cannot act on the pending approval.
<b>Job Opening ID</b>	Displays the job opening ID for the transaction to be approved.
<b>Sender</b>	Displays the primary hiring manager for the job opening. The primary hiring manager is considered the requester even if another user created or submitted the job opening.

<b>Field or Control</b>	<b>Description</b>
<b>Received</b>	Displays the date that you received the request to approve this job opening.
<b>Subject</b>	<p>Job opening approvals start with the text <i>Job Approval</i>. Click a job approval link to access the Job Opening page, where you can view details and approve or deny the job opening.</p> <p>If a job opening’s approval processing has been turned off in the Recruiting Installation component, the link is disabled and the user cannot access the transaction from this page.</p>
<b>&lt;Action&gt;</b>	<p>To approve or deny transactions from the Pending Approvals page, select <i>Approve</i> or <i>Deny</i> from the drop-down list box below the Pending Approvals grid, then click <b>Go</b>.</p> <p>The system approves or denies the selected transactions and removes them from the page.</p>

## Job Opening Page: Approvals Tab

Use the Job Opening page: Approvals tab (HRS\_JOB\_OPENING) to approve a job opening or add approvers or reviewers to the approval process.

This tab is visible after a job has been submitted for approval. However, if approval processing is subsequently turned off in the Recruiting Installation component, this tab is no longer visible.

Navigation:

Click the subject link for a job opening transaction on the [Pending Approvals Page](#).

This example illustrates the Approvals tab on the Job Opening page.

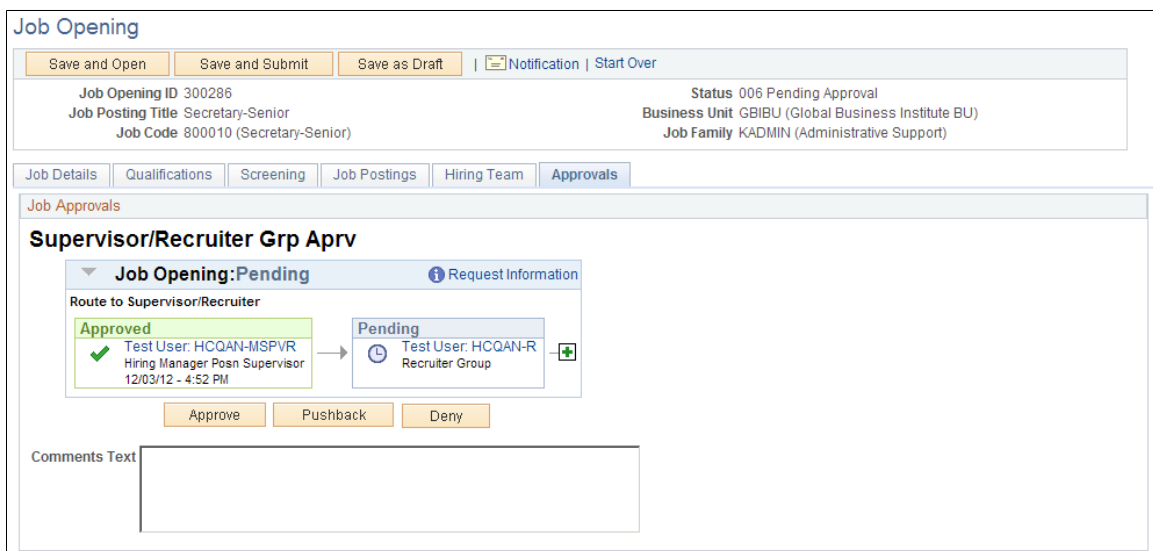

This example illustrates the fields and controls that a recruitment administrator sees on the Job Opening page: Approvals tab.

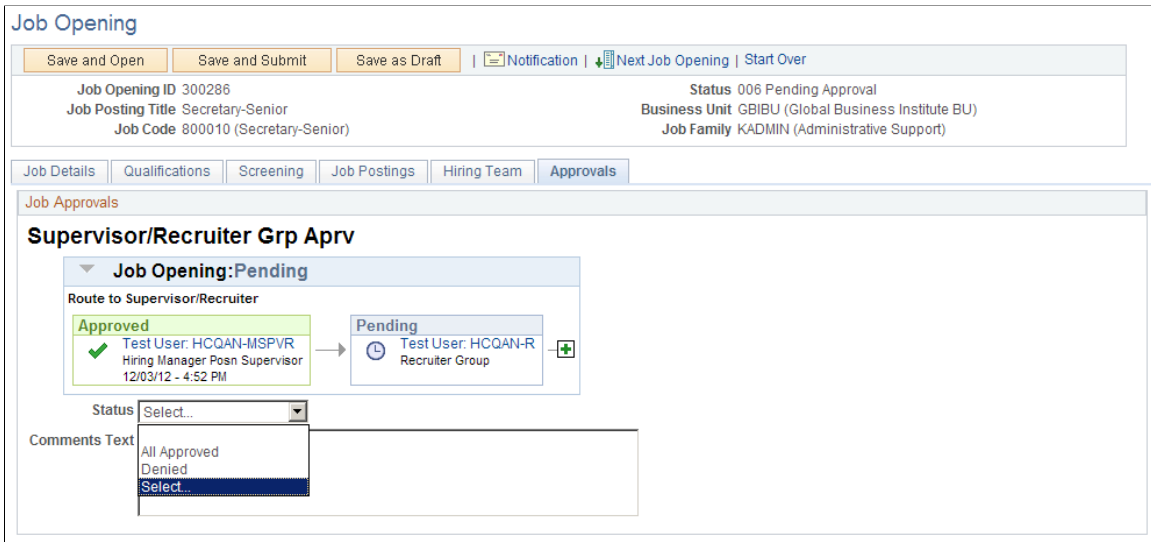

**Note:** The Approvals tab appears on the Job Opening page only after the job is submitted for approval.

### Job Opening: <Approval Status>

This group box displays a graphical representation of the approval process. There is a box for each approver. The box title shows the approver's status, while the box contents include the approver's name, the approver's role in the approval process (for example, the hiring manager's supervisor), and the date, if any, when the approver took action on the approval request.

Additional graphical elements in this group box include color-coding the approver boxes according to the approver's status, and status icons next to the approver's user ID.

Field or Control	Description
<approver User ID>	Click the approver's user ID to display additional information about the approver.
	Click to add another approver or reviewer. A secondary page appears, where you select a user ID and indicate whether you are adding an <i>Approver</i> or <i>Reviewer</i> .

### Approval Controls for Assigned Approvers

The following buttons are visible only to the current approver.

<b>Field or Control</b>	<b>Description</b>
<b>Approve</b>	Click to approve the job opening. When final approval is reached the system changes the job opening status from <i>Pending Approval</i> to <i>Open</i> .
<b>Pushback</b>	This is available only to approvers other than the first approver.  Click to send a notification to the previous approver telling them the job opening needs to be changed.
<b>Deny</b>	Click to reject the job opening and set the job opening status to <i>Denied</i> .

### Approval Control for Administrators

<b>Field or Control</b>	<b>Description</b>
<b>Status</b>	When an administrator views the approval chain, the buttons that the assigned approvers use are not visible. Instead, there is a <b>Status</b> drop-down list box that the approver can use to override the approval process. The administrator can select either <i>All Approved</i> or <i>Denied</i> . The override takes effect when the administrator saves the job opening.  After an administrator overrides the approval process, the approval process status is <i>Terminated</i> , regardless of whether the administrator approved or denied the job opening.

### Approval Control for Requesters

<b>Field or Control</b>	<b>Description</b>
<b>Resubmit</b>	When a job opening has been denied, this button is visible to the requester (the primary hiring manager or, if no hiring managers exist, the creator). Clicking this button sets the job opening status to <i>Pending</i> and starts the approval process over.

## Insert Additional Approver or Reviewer Page

Use the Insert additional approver or reviewer page to add approvers or reviewers to the approval process.

Navigation:

Click the **Insert Approver** icon on the graphical image of the approval process on the Job Opening Page: Approvals Tab.

This example illustrates the Insert additional approver or reviewer page.

Insert additional approver or reviewer

Choose an approver or reviewer to insert

User ID:

Insert as:  Approver  
 Reviewer

<i>Field or Control</i>	<i>Description</i>
<b>User ID</b>	Select the user ID of the person that you want to add.
<b>Insert as</b>	Specify whether this user is added as an approver or reviewer.

## Job Opening Page for Fluid Approvals

Use the fluid Job Opening approval page (EOAWMA\_TXNHDTL\_FL) to approve a job opening.

Navigation:

On the Manager Self-Service home page, click the Approvals tile to access the Pending Approvals page. Then click a job opening entry on the Pending Approvals page.

This example illustrates the fluid Job Opening approval page.

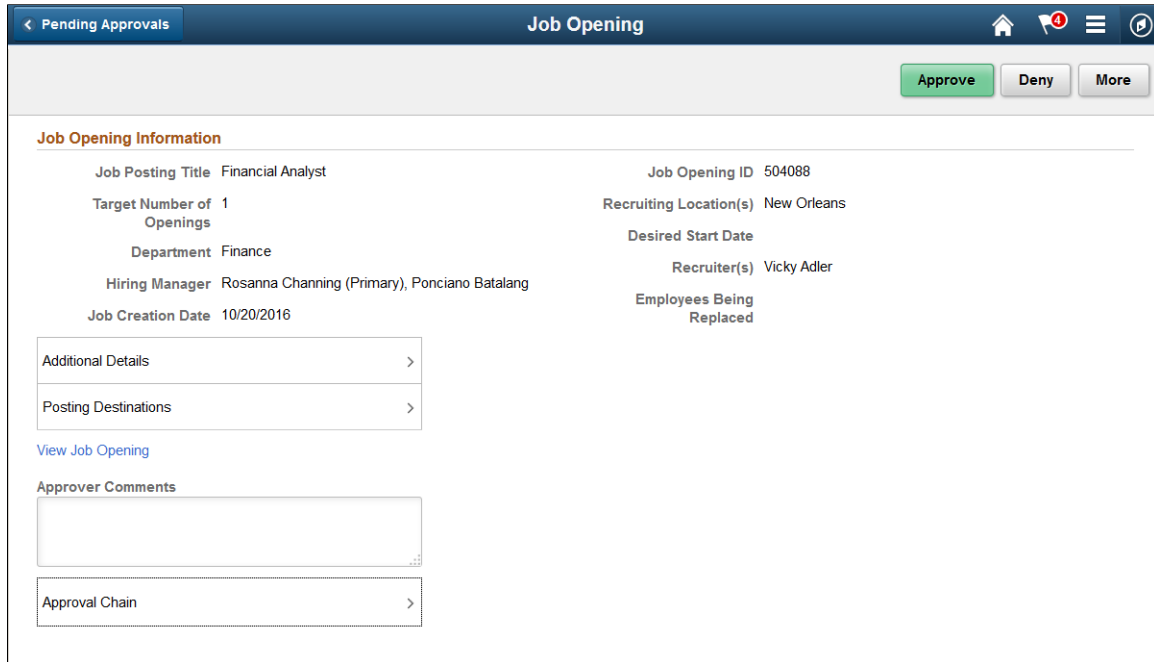

### Approval Options

The approval options on this page are common to all fluid approval transactions, as described in the documentation for the “Pending Approvals - <Transaction Details> Page” (Application Fundamentals).

<b>Field or Control</b>	<b>Description</b>
<b>Approve, Deny, and Pushback</b>	Use these buttons to take action on the requested approval.
<b>Approver Comments</b>	Enter any comments related to the approval action you take.
<b>Approval Chain</b>	Click this item to open the Approval Chain page, where you can review information about all approvers for the transaction.

### Job Opening Information

The job opening fields on this page provides information about the transaction you are being asked to approve. Fields correspond to the same-named fields on the Details tab of the [Manage Job Opening Page](#).

<b>Field or Control</b>	<b>Description</b>
<b>Additional Details</b>	Click this link to access the <a href="#">Additional Details Page</a> , where you can review job specifications such as the job code and the salary range.



<b>Field or Control</b>	<b>Description</b>
<b>Posting Destinations</b>	Click this link to access the <a href="#">Posting Destinations Page</a> , where you can review the posting information for the job opening.
<b>View Job Opening</b>	Click this link to access the Manage Job Opening page where you can review complete job opening information.

## Additional Details Page

Use the Additional Details page (HRS\_JOB\_DTLS\_SCF) to review additional job opening details.

Navigation:

Click the **Additional Details** item on the Pending Approvals - Job Opening page.

This example illustrates the Additional Details page.

<b>Additional Details</b>			
Job Type	Standard Requisition	Job Family	
Company	Swish Hotels - NSW	Business Unit	Swiss Hotels - NSWBU
<b>Job Specifications</b>			
Position Number	Job Code	Salary Range	Pay Frequency
	Financial Analyst - N00026	50,000.00 to 100,000.00 USD	Year

The fields on this page correspond to the same-named fields on the Details tab of the [Manage Job Opening Page](#).

## Posting Destinations Page

Use the Posting Destinations page (HRS\_JOPSTDST\_SCF) to review posting information for a job opening.

Navigation:

Click the **Posting Destinations** item on the Pending Approvals - Job Opening page.

This example illustrates the Posting Destinations page.

<b>Posting Destinations</b>			
Destination / Posting Type	Relative Open Date	Post Date / Remove Date	Posting Duration
Internet / External Posting		/	

The fields on this page correspond to the same-named fields on the Details tab of the [Manage Job Opening Page](#).



## Chapter 17

# Searching for and Managing Job Openings

---

## Searching for Job Openings

This topic discusses how to search and browse for job openings.

### Pages Used to Search for Job Openings

<i>Page Name</i>	<i>Definition Name</i>	<i>Usage</i>
<a href="#">Search Job Openings Page</a>	HRS_JO_FIND_JOB	Search for job openings using a simple database search.
<a href="#">Browse Job Openings Page</a>	HRS_JOB_OPNG_SRCH	Search for job openings using a combination of keyword searching and faceted filtering.

### Search Job Openings Page

Use the Search Job Openings page (HRS\_JO\_FIND\_JOB) to search for job openings using a simple database search.

Navigation:

**Recruiting > Search Job Openings**

This example illustrates the Search Job Openings page as it initially appears, before you perform a search.

The screenshot shows the 'Search Job Openings' page with the following search criteria fields:

- Job Posting Title
- Job Opening ID
- Status: Open
- Category
- Most Recent Activity
- Job Opening Type
- Hot Job
- My Association
- Hiring Manager
- Recruiter
- Created By
- Business Unit
- Department
- Position Number
- Recruitment Contact

Buttons for 'Search' and 'Clear' are located at the bottom of the search criteria section.

This example illustrates the Search Job Openings page after you perform a search. The search criteria section is now collapsed, and the page now shows the search results.

The screenshot shows the search results section with 4 results found. The search criteria section is collapsed. The results are displayed in a table:

Select	Job Opening	Job ID	Status	Type	Category	Recruiting Location	Target Openings	Available Openings	Hot Job	Created
<input type="checkbox"/>	HRMS Analyst-35000	300008	Open	Standard Requisition		California	1	1		01/07/2009
<input type="checkbox"/>	Analyst-HRMS	290036	Open	Standard Requisition		Corporation Headquarters	1	1		06/10/2002
<input type="checkbox"/>	HRMS Analyst	35000	Open	Standard Requisition		California	1	1		09/13/2004
<input type="checkbox"/>	Administrator-HRMS	10239	Open	Standard Requisition		Corporation Headquarters	1	1		03/27/2006

Below the table are controls for 'Select All', 'Deselect All', and 'Group Actions'.

### Toolbar

<b>Field or Control</b>	<b>Description</b>
<b>Recruiting Home</b>	Click to access the <a href="#">Recruiting Home Page</a> .

<b>Field or Control</b>	<b>Description</b>
<b>Browse Job Openings</b>	Click to access the <a href="#">Browse Job Openings Page</a> .
<b>Create Job Opening</b>	Click to access the <a href="#">Primary Job Opening Information Page</a> , where you start the process of creating a new job opening.
<b>Search Job Postings</b>	Click to access the <a href="#">Search Job Postings Page</a> , where you can search for job postings.

## Search Criteria

Initially, the **Search Criteria** section is expanded and displays all available search fields. After you perform a search, this section is collapsed.

<b>Field or Control</b>	<b>Description</b>
<b>Job Posting Title</b>	Enter text to look for in the job posting title. The system searches for job openings that contain the text you enter; an exact match is not necessary.
<b>Job Opening ID</b>	<p>Enter a single job opening ID. Searching by ID is the most efficient way to access the record for a specific job opening whose ID you know.</p> <p>When prompting for the job opening ID, users see only the job openings to which they have security access.</p>
<b>Status</b>	<p>Select a job opening status. The default value is the default job opening status specified on the <a href="#">Recruiting Status Area Page</a>. As delivered, the default is <i>Open</i>.</p> <p>The value in this field affects which group actions you can perform on your search results. For example, approval-related group actions are available only if you use this field to limit search results to job openings in either <i>Pending</i> or <i>Denied</i> status.</p>
<b>Category</b>	<p>Select one of your personal job opening categories. The drop-down list displays an alphabetical list of category descriptions.</p> <p>This field is visible only if job categorization is enabled on the <a href="#">Recruiting Installation – Jobs Page</a>.</p>

<b>Field or Control</b>	<b>Description</b>
<b>Most Recent Activity</b>	<p>To search based on how recently the job opening has had a status change, select the time period to check for status-related activity: <i>Active within Today, Active within Yesterday, Active within Last 3 Days, Active within Last Week, Active within Last 2 Weeks, Active within Last Month, Active within Last Year, or Active within View All.</i></p> <p>Changes other than status changes are not considered activity for purposes of searching based on when the most recent activity occurred.</p>
<b>Job Opening Type</b>	Select <i>Continuous Job Opening</i> or <i>Standard Requisition</i> .
<b>Hot Job</b>	Select <i>Yes</i> or <i>No</i> to filter results according to whether the job opening is a hot job.
<b>My Association</b>	<p>Select a value representing your association with the job opening. Options are:</p> <ul style="list-style-type: none"> <li>• <i>All Jobs</i></li> <li>• <i>Jobs Assigned to me</i></li> </ul> <p>A job is assigned to you if you are the primary hiring manager or primary recruiter</p> <ul style="list-style-type: none"> <li>• <i>Jobs Associated to me</i></li> </ul> <p>A job is associated with you if you created it, if you are on the hiring team in any capacity, or if you are part of the approval chain.</p> <ul style="list-style-type: none"> <li>• <i>Jobs Created by me</i></li> </ul>
<b>Hiring Manager, Recruiter and Created By</b>	To search for job openings that are associated with a particular hiring manager, recruiter, or creator, enter that person's employee ID in the appropriate field.
<b>Business Unit</b>	Use this field to search based on the job opening's business unit.
<b>Department</b>	Use this field to search based on the job opening's department. This field is available only after you enter a business unit.
<b>Position Number</b>	Use this field to search based on the primary position number for the job opening.

<b>Field or Control</b>	<b>Description</b>
<b>Recruitment Contact</b>	Select an external recruitment contact. The drop-down list shows the names of contacts that have been defined on the <a href="#">Contact Setup Page</a> with a contact type of <i>Office</i> .
<b>Search</b>	Click this button to perform the search using the criteria you've entered.
<b>Clear</b>	Click this button to restore the search criteria fields to their default state. In this state, all of the fields are blank except the <b>Status</b> field, where the default value is <i>Open</i> .

## Search Results

The Search Results grid displays the job openings that meet your search criteria. Job opening security prevents the system from showing any job openings to which you do not have access.

<b>Field or Control</b>	<b>Description</b>
<b>Select</b>	Before performing a group action, use this check box to select the job openings to which the group action applies.
<b>Job Opening and Job ID</b>	These fields display identifying information about the job opening. If the job opening is in a draft, pending, or denied status, clicking the job opening title opens the <a href="#">Job Opening Page</a> . If the job opening has ever been opened, clicking the job opening title opens the <a href="#">Manage Job Opening Page</a> .
<b>Status</b>	Displays the job opening's current status.
<b>Type</b>	Displays the job opening type, either <i>Standard Requisition</i> or <i>Continuous Job Opening</i> .
<b>Category</b>	<p>If job categorization is enabled on the <a href="#">Recruiting Installation – Jobs Page</a>, this column enables you to view and change the category for the job opening. Categories are a personal organizational tool, and your categorization is not visible to other users.</p> <p>To change a job's category, click the Category icon to access the <a href="#">My Job Categories Page</a>, where a single click assigns a category and returns you to the Search Job Openings page.</p>

<b>Field or Control</b>	<b>Description</b>
<b>Recruiting Location</b>	Displays the primary recruiting location for the job opening.
<b>Target Openings</b> and Available Openings	Displays information about the total number of positions to be filled and the number that have not yet been filled.
 <b>Hot Job</b>	Displays the hot job icon for any jobs that are hot jobs.
<b>Created</b>	Displays the date that the job opening was created.

### Page Elements for Performing Actions

<b>Field or Control</b>	<b>Description</b>
<b>Select All</b> and <b>Deselect All</b>	Use these links to select or deselect grid rows so that you can perform group actions on the selected rows.
<b>Group Actions</b>	Click to display a menu of actions that you can perform for the selected job openings, then select an action to perform.

The following table lists group actions and describes when each action is available and what it does.

<b>Action</b>	<b>Availability</b>	<b>Usage</b>
Add Note	Always available.	Select this action to create a note that will be added to all of the selected job openings.
Delete	Available only when you search for job openings where the status is <i>Draft</i> .	Performing this action deletes the selected draft job openings.
Approve, Deny, and Pushback	Available only when you search for job openings where the status is <i>Pending</i> or <i>Denied</i> .	<p>Use these actions to perform approval-related actions.</p> <p>If a user other than the assigned approver (or that approver's proxy) initiates an approval-related action, the action will not update the job opening.</p> <hr/> <p><b>Note:</b> Although administrators can override approvals, they must perform approval actions on the Job Opening page. This ensures that the administrator reviews the job opening data before taking action.</p> <hr/>



<b>Action</b>	<b>Availability</b>	<b>Usage</b>
Cancel, Close, and Hold	Available only when you search for job openings where the status is <i>Open</i> .	<p>Performing these actions makes a corresponding status change to all selected job openings.</p> <hr/> <p><b>Note:</b> For security reasons, recruiting administrators are the only users who can make direct edits to the Status Code field on the Job Opening page. Therefore, non-administrators who want to close a job opening, cancel it, or put it on hold must do so using the actions on the Search Job Openings page.</p>

## Browse Job Openings Page

Use the Browse Job Openings page (HRS\_JOB\_OPNG\_SRCH) to search for job openings using a combination of keyword searching and faceted filtering.

**Important!** You must deploy the HC\_HRS\_JOB\_OPENING search definition and build the index before you can use the Browse Job Openings page.

Navigation:

**Recruiting > Browse Job Openings**

This example illustrates the Browse Job Openings page.

The screenshot shows the 'Browse Job Openings' interface. At the top, there is a search bar with the text 'Search job openings' and a search icon. Below the search bar, there are filter tags: '010 Open', 'Created by Me', and 'Douglas Lewis', along with a 'Clear All Filters' link. On the left side, there is a 'Filter by' section with several categories and their counts: 'My Association' (Created by Me: 4), 'Recruiting Location' (Corporation Headquarters: 3, California Location: 1), 'Department' (Human Resources: 2, Finance and Administration: 1, Public Affairs: 1), 'Hiring Manager' (Douglas Lewis: 4), 'Recruiter' (Betty Locherty: 4), 'Job Family' (Administrative Support: 2, Executive: 1, Legal: 1), and 'Status' (010 Open: 4). Below the filters, there is a table titled 'Job Openings' with 4 matches found. The table has columns for Job ID, Posting Title, Category, Recruiting Location, Department, Business Unit, Hiring Manager, Days Open, Status, No Action Taken, and Total Applicants. The data rows are as follows:

Job ID	Posting Title	Category	Recruiting Location	Department	Business Unit	Hiring Manager	Days Open	Status	No Action Taken	Total Applicants
504026	Director of Finance	Finance	Corporation Headquarters	Finance and Administration	Global Business Institute BU	Douglas Lewis	122	010 Open	0	0
504004	Executive Services Administrat...	Human Resources	Corporation Headquarters	Human Resources	Global Business Institute BU	Douglas Lewis	211	010 Open	0	12
504002	Administrative Coordinator	Human Resources	Corporation Headquarters	Human Resources	Global Business Institute BU	Douglas Lewis	209	010 Open	3	3
500404	Junior Counsel Position - Refe...	Public Affairs	California Location	Public Affairs	Global Business Institute BU	Douglas Lewis	1332	010 Open	3	3

## Understanding the Browse Job Openings Page

The Browse Job Openings page displays a grid listing the job openings that meet your criteria. You can specify criteria two ways:

- Perform a keyword search using the search field that appears above the grid.
- Use the **Filter By** area to the left of the grid to choose filtering criteria.

The Filter By fields provides faceted filtering capability based on data such as the recruiting location, department, hiring manager, and so forth. Each field displays a set of links listing available values. The number next to each value indicates how many jobs in the current list have that value. Clicking a link activates the filter, updates the job openings grid, and updates the Filter By area to show only values that exist in the current set of job openings.

For example, suppose the job opening grid initially lists 100 openings. In the Filter By area, the Department filter includes multiple links, including one labeled *Human Resources (30)*. This indicates that 30 of the 100 openings are in the Human Resources department. After you click the Human Resources link, the job openings grid lists only those 30 openings, and the other values for the Department field disappear because the other departments are no longer represented in the current set of openings. At the same time, the values for other filter fields change. Perhaps the original 100 openings included openings from seven different recruiting locations, but after you click the Human Resources link, the remaining 30 jobs represent only three recruiting locations. In this situation, applying the department filter shortens the list of filtering values for the Recruiting Location field.

As you click the filtering links, each filter criteria appears directly above the Job Openings grid. To remove a filter, click the adjacent *x* (the Remove Filter icon).

---

**Note:** The search and filtering capabilities of the Browse Job Openings page are powered by the PeopleTools Search Framework. Therefore, the job openings grid on this page observes any system-wide setting that sets the maximum number of search results. This page has an additional restriction limiting the grid to 300 applicants, even if the system-wide maximum is higher.

---

## Toolbar

<b>Field or Control</b>	<b>Description</b>
<b>Return</b>	Click to return the page from which you accessed this page.
<b>Recruiting Home</b>	Click to access the <a href="#">Recruiting Home Page</a> .
<b>Browse Applicants</b>	Click to access the <a href="#">Browse Applicants Page</a> , where you can search for applicants using a combination of keyword searching and faceted filtering.
<b>Search Job Openings</b>	Click to display the <a href="#">Search Job Openings Page</a> , where you can search for job openings using a simple database search.
<b>Create Job Opening</b>	Click to access the <a href="#">Primary Job Opening Information Page</a> , where you start the process of creating a new job opening.
<b>Personalize</b>	Click to change the content and layout of the toolbar.

## Keyword Search

<i>Field or Control</i>	<i>Description</i>
 Search	<p>Use the text field under the toolbar to enter search terms, then click the Search icon to perform the search.</p> <p>Keyword search criteria is not listed with the currently active filters (in the area just below the keyword search field), so there is no corresponding Remove Filter icon. Instead, you clear the search directly in the text field.</p>

## Active Filters

<i>Field or Control</i>	<i>Description</i>
 Remove Filter	<p>Above the Job Openings grid, the page displays your currently active filters. Click the Remove Filter icon next to an active filter to remove the filter.</p>
<b>Clear All Filters</b>	<p>Click to remove all field-based filters. Clicking this link does not clear the keyword search filtering.</p>

## Filter By

---

**Note:** Filtering facets can be added and removed in the HC\_HRS\_JOB\_OPENING search definition. For example, because Business Unit is already part of the search index, you can easily add a Business Unit facet. However, be aware that adding facets can degrade performance. For more information, see [Configuring Recruiting Search Facets](#).

---

<i>Field or Control</i>	<i>Description</i>
<b>My Association</b>	<p>The available filters based on for your association with the job opening are: <b>Created By Me, Hiring Manager, Primary Hiring Manager, Recruiter, Primary Recruiter, and Team Member</b> Team members include approvers as well as the members of the job opening hiring team.</p> <p>The Hiring Manager filter shows job openings where you are the primary or non-primary hiring manager. Similarly, the Recruiter filter shows job openings where you are the primary or non-primary hiring manager.</p>

<b>Field or Control</b>	<b>Description</b>
<b>Recruiting Location</b>	<p>Use this field to filter based on the job opening’s recruiting location(s). If a job has multiple recruiting locations, all of the recruiting locations are represented in the list of facets.</p> <p>This facet offers hierarchical filtering based on the recruiting location hierarchy that you set up on the <a href="#">Recruiting Locations Page</a>. The initial list of values in the recruiting location facet includes only top-level recruiting locations (including recruiting locations that are not part of any hierarchy). For example, if the top level of your hierarchy is for countries, then the recruiting location facet lists the countries where you have job postings. Clicking a country name drills into the hierarchy, and facet now lists the next level of the hierarchy.</p> <p>Recruiting location hierarchies are limited to five levels (the top level and up to four levels of nested recruiting locations).</p>
<b>Department</b>	<p>Use this field to filter based on the job opening’s department.</p>
<b>Hiring Manager</b>	<p>Use this field to filter based on the job opening’s primary hiring manager. Non-primary hiring managers are not considered.</p>
<b>Recruiter</b>	<p>Use this field to filter based on the job opening’s primary recruiter. Non-primary recruiters are not considered.</p>
<b>Job Family and Job Code</b>	<p>This field offers hierarchical filtering based first on job family and then, after you select a job family, based on the job codes that are associated with the selected job family.</p> <p>The job families that are listed for this field are the families that are associated with the primary job codes of the job openings. Non-primary job codes are not considered.</p> <p>If job family is not relevant to users, modify the HC_HRS_JOB_OPENING search definition to remove the job family facet. If you disable the job family facet, you can still keep job code as a non-hierarchical facet.</p>
<b>Status</b>	<p>Use this field to filter based on the job opening status.</p> <p>When you access the Browse Job Openings page, the system automatically applies the status filter (if any) that is selected as the <b>Default Job Status for Browse Job Openings Page</b> on the <a href="#">Recruiting Installation – Jobs Page</a> page. As delivered, the default filter is the <i>Open</i> status.</p>

<b>Field or Control</b>	<b>Description</b>
<b>Created In</b>	This field offers hierarchical filtering based first on the year that the job opening was created and then, after you select a year, based on the month that the job opening was created.

## Job Openings

This grid displays a list of job openings that meet your current browsing criteria. Job opening security prevents the system from showing any job openings to which you do not have access.

<b>Field or Control</b>	<b>Description</b>
<b>Job ID and Posting Title</b>	These fields display identifying information about the job opening. If the job opening is in a draft, pending, or denied status, clicking the job opening title opens the <a href="#">Job Opening Page</a> . If the job opening has ever been opened, clicking the job opening title opens the <a href="#">Manage Job Opening Page</a> .
<b>Category</b>	<p>If job categorization is enabled on the <a href="#">Recruiting Installation – Jobs Page</a>, this column enables you to view and change the category for the job opening. Categories are a personal organizational tool, and your categorization is not visible to other users.</p> <p>To change a job’s category, click the Category icon to access the <a href="#">My Job Categories Page</a>, where a single click assigns a category and returns you to the Search Job Openings page.</p>
<b>Recruiting Location</b>	Displays the primary recruiting location for the job opening.
<b>Department and Business Unit</b>	These fields display the department and business unit of the job opening.
<b>Hiring Manager or Recruiter</b>	<p>This column displays either the job opening’s primary hiring manager or the job opening’s primary recruiter, depending on the roles assigned to the current user:</p> <ul style="list-style-type: none"> <li>• If the user has a <i>Recruiter</i>, <i>Recruiting Manager</i>, or <i>Recruitment Administrator</i> role, the Hiring Manager column appears.</li> <li>• If the user has a <i>Hiring Manager</i> role (and not any of the other roles listed), the Recruiter column appears.</li> </ul>

<b>Field or Control</b>	<b>Description</b>
<b>Days Open</b>	For job openings in an open status, this column displays the number of days since the job opening's earliest posting date. If the job has never been posted, this field displays the number of days since the job opening was created. If the earliest job posting date (or, if none, the job creation date) is in the future, the system displays 0.
<b>Days to Fill Date</b>	Displays the number of days remaining until the projected fill date.  This data appears only for job openings in open statuses that have projected fill dates. If none of the job openings in the grid meet this criteria (for example, if you use the <b>Status</b> filter to show only jobs in <b>Pending</b> status), this column is hidden.
<b>Status</b>	Displays the current status of the job opening.
<b>No Action Taken</b>	Displays the number of applicants in the Applied phase. Click this number to access the Manage Job Opening page pre-filtered to show only applicants in this phase.
<b>Total Applicants</b>	Displays the total number of applicants that have applied for the job. Applicants with multiple applications are counted only once, and draft applications are not considered.
 <b>Hot Job</b>	Displays the hot job icon for any jobs that are hot jobs. This column is hidden entirely if none of the job openings are hot jobs.

---

## Managing Job Openings

This topic provides an overview of the Manage Job opening pages and discusses how to perform job opening-related and applicant-related activities for the job opening.

This Talent Acquisition Manager overview video includes a demonstration of the Manage Job Opening page:

Video: [Talent Acquisition Manager Overview](#)

## Pages Used to Manage Job Openings

<b>Page Name</b>	<b>Definition Name</b>	<b>Usage</b>
<a href="#">Manage Job Opening Page</a>	HRS_JO_360	Manage all aspects of a job opening, including managing applicants, searching for applicants, reviewing activity, creating notes, attachments, and expenses, and viewing or updating the job opening details.
<a href="#">Manage Job Opening Page: Applicants Tab</a>	HRS_JO_360	Review applicants and perform applicant-specific recruiting activities.
<a href="#">Manage Job Opening Page: Applicant Search Tab</a>	HRS_REC_SCHAPP	Search for qualified applicants. Also, review saved automatch searches and saved compliance searches for the job opening.  This tab embeds the <a href="#">Search Applicants Page</a> into the job opening, and is only visible to users who have security access to the Search Applicants page.
<a href="#">Manage Job Opening Page: Applicant Screening Tab</a>	HRS_JO_SCR_LVL	Review screening levels, run screening processes, and review screening results.  This tab is visible only if the user has security access to the page. Also, it is visible only if the job opening has at least one standard screening level (a screening level that is not for prescreening or online screening).
<a href="#">Manage Job Opening Page: Activity &amp; Attachments Tab</a>	HRS_JO_360	Use this tab to review the job's status history and to manage job-related notes, attachments, and expenses. This tab also displays the same saved searches that appear on the Applicant Search tab.
<a href="#">Job Opening Notes Page</a>	HRS_JO_NOTE_SEC	Enter details for a job opening note.
<a href="#">Add Expenses Page</a>	HRS_JO_EXPENSE_SEC	Enter details for a job opening expense.
<a href="#">Manage Job Opening Page: Details Tab</a>	HRS_JOB_OPENING	Manage job opening data, including general job information, job qualifications, screening settings, postings, and hiring team members.  This tab corresponds to the <a href="#">Job Opening Page</a> where you originally created the job opening. The job opening template controls the content and layout of this tab's subsections.

## Understanding the Manage Job Opening Page

The Manage Job Opening page provides a single point from which you can complete many recruiting tasks for a job opening and its applicants. The page includes:

- Five tabs where manage applicant and job opening information.
- A toolbar that provides access to additional features for organizing and reviewing job opening data.
- An additional link that provides access to related content charts.

See [Viewing Related Content Charts for Job Openings](#).

This diagram illustrates structure of the Manage Job Opening page. Note that the Applicants tab and the Activity & Attachments tab do not have subsections.

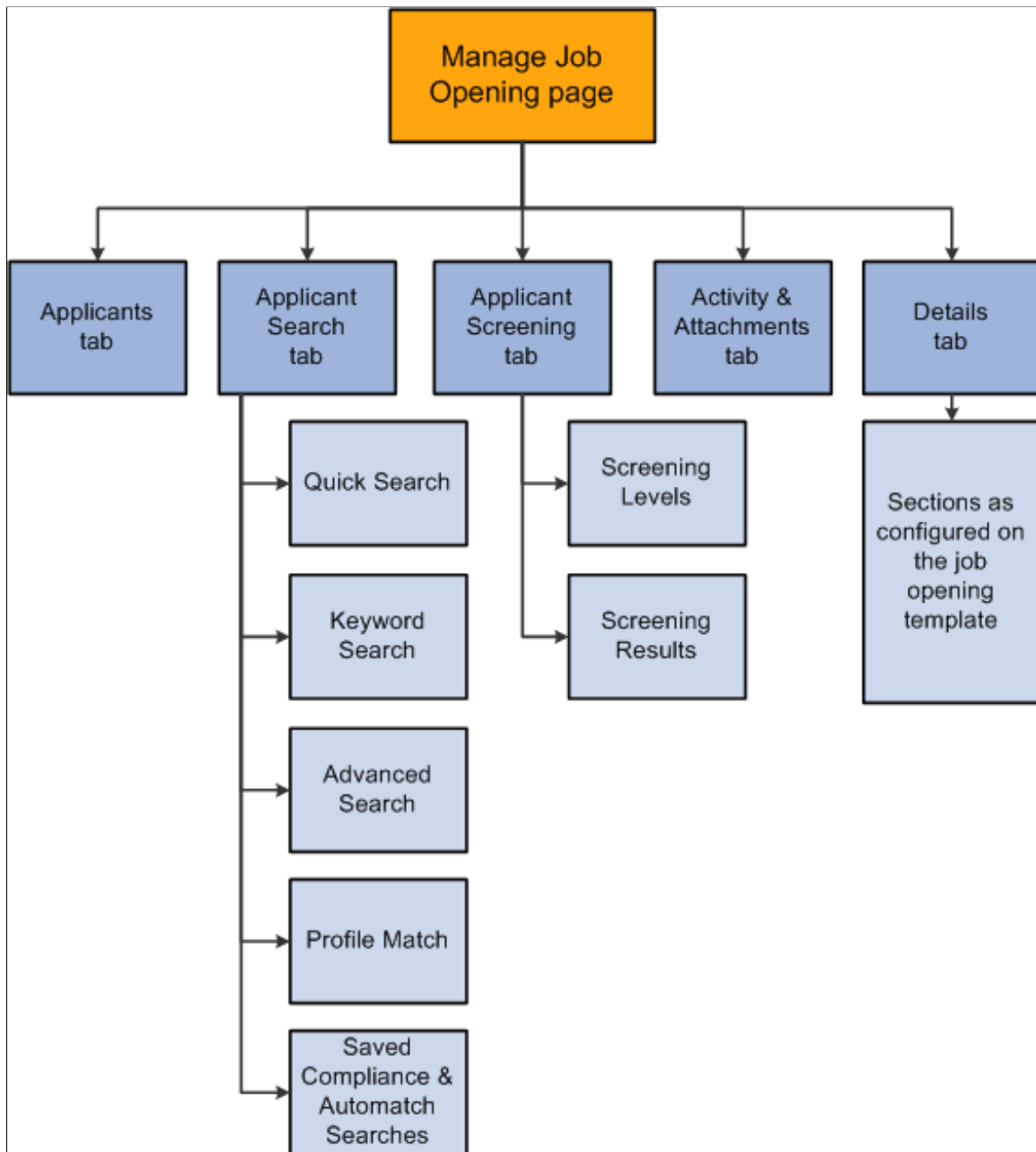



## Manage Job Opening Page

Use the Manage Job Opening Page (HRS\_JO\_360) to manage all aspects of a job opening, including managing applicants, finding applicants, reviewing activity, tracking notes and attachments, tracking expenses, and viewing or updating the job opening details.

Navigation:

### Recruiting > Search Job Openings

Click the job opening link in Search Results group box on the Search Job Openings page.

**Note:** You can also access this page by clicking a job opening on the Recruiting Home page, the Browse Job Openings page, the Manage Applicant page, the Manage Application page, Search Applications page, and many other pages that include job opening information.

This example illustrates the Manage Job Opening page.

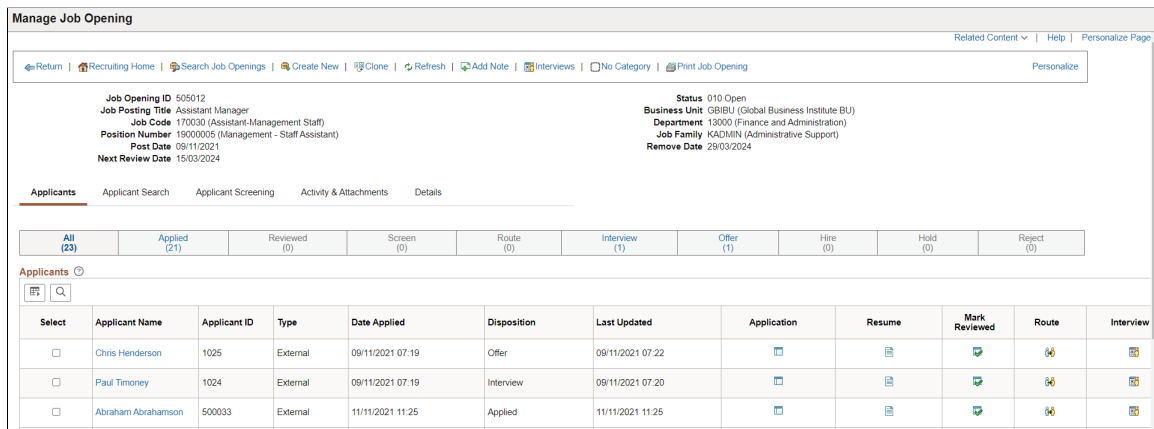

## Toolbar

Field or Control	Description
<b>Save</b>	This button is visible only when you are on the Activity & Attachments tab or the Details tab. Click to save any changes you make to the data on these tabs.
<b>Return</b>	<p>If you accessed the job opening by clicking a link on another recruiting page, click the <b>Return</b> toolbar button to return to the previous page.</p> <p>If you accessed this page using the global search and you want to return to your search results, use the Last Search Results link (next to the global search field) instead of the <b>Return</b> toolbar button.</p>
<b>Recruiting Home</b>	Click to access the <a href="#">Recruiting Home Page</a> .

<b>Field or Control</b>	<b>Description</b>
<b>Search Job Openings</b>	Click to access the <a href="#">Search Job Openings Page</a> .
<b>Previous and Next</b>	These buttons appear if you accessed the Manage Job Opening page from a grid that listed multiple job openings. Use the buttons to navigate between openings.
<b>Create New</b>	Click to access the <a href="#">Primary Job Opening Information Page</a> , where you begin the process of creating a job opening.
<b>Clone</b>	Click to access the <a href="#">Clone Job Opening Page</a> , where you can create new job openings based on the current job opening.
<b>Refresh</b>	This button is visible only when you are on the Applicants tab. Click to refresh the data on the page.
<b>Add Note</b>	Click to create a new job opening note on the <a href="#">Job Opening Notes Page</a> .
<b>Interviews</b>	Click to access the <a href="#">Interview Summary Page</a> , which provides a read-only summary of all interviews that have been scheduled for the job opening.
<b>Category</b>	<p>Displays the icon for the personal category that you have assigned to the job (or the No Category icon if appropriate). Categories are a personal organizational tool, and your categorization is not visible to other users.</p> <p>Click the icon to access the <a href="#">My Job Categories Page</a>, where you can change the category.</p>
<b>Print Job Opening</b>	Click to access the <a href="#">Select Job Opening Sections Page</a> , where you generate the Job Opening report after selecting which data to include in the report.
<b>Personalize</b>	Click to change the content and layout of the toolbar.

## Header Data

**Note:** If a header field does not have a value for a particular job opening, the field is hidden in the header. System-wide configuration options such as the template segmenting type and the position management option can cause related header fields to be hidden for all job openings.

<b>Field or Control</b>	<b>Description</b>
<b>Job Opening ID</b>	Displays the job opening's unique identifier.
<b>Status</b>	Displays the job opening's current status.
<b>Job Posting Title</b>	Displays the job opening's descriptive title.
<b>Business Unit</b>	Displays the job opening's business unit. All job openings are associated with business units.
<b>Job Code</b>	Displays the primary job code for the opening. If a job opening does not have a job code (which is not required for continuous job openings), this field is hidden.
<b>Department</b>	Displays the job opening's department. If the job opening is not associated with a <b>Department</b> , this header field is hidden.
<b>Position Number</b>	Displays the primary position for the opening. If you do not use position management, or if you use partial position management and the job opening does not specify a position, then this header field is hidden.
<b>Job Family, Job Profile ID, Company, or Salary Grade</b>	<p>If one of these fields is used as the template segmenting type, the field appears in the header. Because there can be only one template segmenting type, the header never displays more than one of these fields.</p> <p>When the template segmenting type is Salary Grade, the Salary Grade field displays both the salary plan and the salary grade.</p>
 <b>Hot Job</b>	<p>The Hot Job field and icon appear when the job is a hot job.</p> <p>See <a href="#">Managing Hot Jobs</a>.</p>
<b>Post Date, Remove Date, and Next Review Date</b>	These fields appear in the header if the job has a primary posting with primary posting destination enabled, and the post date, remove date and next review date is available for the posting destination. See <a href="#">Posting Information Page</a> .

## Tabs

<b>Field or Control</b>	<b>Description</b>
<b>Applicants</b>	Use the <a href="#">Manage Job Opening Page: Applicants Tab</a> to review applicants and perform applicant-specific recruiting activities.
<b>Applicant Search</b>	Use the <a href="#">Manage Job Opening Page: Applicant Search Tab</a> to search for applicants to link to the job opening.
<b>Applicant Screening</b>	Use the <a href="#">Manage Job Opening Page: Applicant Screening Tab</a> to run screening processes.  See <a href="#">Running Screening Levels and Applying Results</a> .
<b>Activity &amp; Attachments</b>	Use the <a href="#">Manage Job Opening Page: Activity &amp; Attachments Tab</a> to review the job’s status history along with job-related notes, attachments, expenses, and saved applicant searches.
<b>Details</b>	Use the <a href="#">Manage Job Opening Page: Details Tab</a> to manage job opening data, including general job information, job qualifications, screening settings, postings, and hiring team members.

## Manage Job Opening Page: Applicants Tab

Use the Manage Job Opening page: Applicants tab (HRS\_JO\_360) to review applicants for a job opening and perform various applicant-related activities.

Navigation:

**Recruiting > Search Job Opening**

The [Manage Job Opening Page](#) appears, and the Applicants tab is the first tab on the page.

This example illustrates the Applicants page under Manage Job Opening page.

Manage Job Opening													
<a href="#">Return</a>   <a href="#">Recruiting Home</a>   <a href="#">Search Job Openings</a>   <a href="#">Create New</a>   <a href="#">Clone</a>   <a href="#">Refresh</a>   <a href="#">Add Note</a>   <a href="#">Interviews</a>   <a href="#">No Category</a>   <a href="#">Print Job Opening</a>										Personalize			
Job Opening ID 505012 Job Posting Title Assistant Manager Job Code 170030 (Assistant Management Staff) Position Number 19000005 (Management - Staff Assistant)						Status 010 Open Business Unit GIBIU (Global Business Institute BU) Department 13000 (Finance and Administration) Job Family KACMWN (Administrative Support)							
<a href="#">Applicants</a>   <a href="#">Applicant Search</a>   <a href="#">Applicant Screening</a>   <a href="#">Activity &amp; Attachments</a>   <a href="#">Details</a>													
All (27)		Applied (25)		Reviewed (1)		Screen (0)		Hire (0)		Hold (0)		Reject (0)	
Applicants													
<input type="text"/>													
Select	Applicant Name	Applicant ID	Type	Date Applied	Disposition	Last Updated	Employee Referral	Former Employee	Veteran	Military Status	Application		
<input type="checkbox"/>	Chris Henderson	1025	External	09/11/2021 07:19	Offer	09/11/2021 07:22							
<input type="checkbox"/>	Paul Timoney	1024	External	09/11/2021 07:19	Reviewed	22/10/2023 21:52							
<input type="checkbox"/>	Abraham Abrahamson	500033	External	11/11/2021 11:25	Applied	11/11/2021 11:25							
<input type="checkbox"/>	Antonette Gisella	500022	External	11/11/2021 11:25	Applied	11/11/2021 11:25							
<input type="checkbox"/>	Bradleigh Tayelor	500030	External	11/11/2021 11:25	Applied	11/11/2021 11:25							
<input type="checkbox"/>	Brian Novalessa	500023	External	11/11/2021 11:25	Applied	11/11/2021 11:25							
<input type="checkbox"/>	Brian Parkersohn	300131	External	22/10/2023 22:10	Applied	22/10/2023 22:10			Yes	Protected, Not Classified			

## Flexible Processing and Applicant Actions

A job opening's flexible recruiting process (if any) defines appropriate actions based on a user's role and an applicant's current disposition. If the flexible recruiting process disallows a particular action, the Manage Job Opening page does not display the icons or menu commands that would be used to perform the action. Hiding the irrelevant actions helps users to focus on the appropriate next steps in the recruiting process.

These actions can be made unavailable: Reject Applicant, Route Applicant, Manage Interviews, Created Interview Evaluation, Prepare Job Offer, Accept Offer, Reject Offer, Pre-Employment Check, Prepare for Hire, Withdraw from Hire, and Manage Applicant Contracts. (Although flexible processing can make the Manage Interviews action unavailable, it does not affect whether the Interviews toolbar button appears.)

Additionally, the Edit Disposition action is hidden if the flexible recruiting process does not provide the user with any valid disposition transitions.

When a flexible recruiting process makes actions unavailable:

- The Applicants grid hides icons for unavailable actions, and the column where the icon appears is hidden entirely if an action is not valid for any applicants.
- The Other Actions menu (for performing actions on individual applicants) hides any actions that are not available for the applicant.
- The Group Actions menu does not hide actions, but the system performs the action for only those job openings where the action is permitted.

## Disposition Phase Filter





Across the top of the Applicants tab, a horizontal bar provides a graphical representation of the phases of the recruiting process, with labels indicating both the phase name and the number of applicants currently in dispositions that belong to that phase. Dispositions are associated with phases on the [Recruiting Status and Reason Page](#). To hide any recruitment phase from the filter, see [Recruiting Installation – Manage Jobs Page](#).





<b>Field or Control</b>	<b>Description</b>
<Phase name> and <number of applicants in phase>	<p>The bar includes a section for every phase that has at least one associated disposition, even if the current job opening does not have any applicants in that phase. <i>All</i>, which appears before the first phase, represents all phases.</p> <p>Phase bar sections with at least one applicant are clickable. Clicking a section updates the Applicants grid so that it shows only applicants in the specified phase.</p> <p>Normally, the page initially shows <i>All</i> phases. However, if you access the page by clicking the number in the <b>No Action Taken</b> column on the My Job Openings pagelet, the system automatically uses the <i>Applied</i> phase as the filter. (The term “No Action Taken” refers to applicant who are still in the first phase of the application process.)</p> <hr/> <p><b>Note:</b> Be sure that all non-draft dispositions are associated with recruiting phases. The number shown for the <i>All</i> phase does not include applicants in dispositions that are not associated with phases. (However, those applicants are still shown in the Applicants grid when you click the <i>All</i> phases link.)</p>

## Applicants

This grid displays applicants who are linked to the current job opening with a non-draft disposition.

<b>Field or Control</b>	<b>Description</b>
<b>Select</b>	Before performing a group action, use this check box to select the applicants to which the group action applies.
<b>Applicant Name and Applicant ID</b>	These fields display identifying information about the applicant. Click the <b>Applicant Name</b> link to display the <a href="#">Manage Applicant Page</a> .
<b>Type</b>	Possible applicant types are <i>Employee</i> , <i>External</i> , and <i>Non-Employee</i> . Non-employees are applicants such as contingent workers who have non-employee HR records.
<b>Date Applied</b>	Displays the date when the application was submitted.
<b>Disposition</b>	Displays the applicant's current disposition for this job opening.

<b>Field or Control</b>	<b>Description</b>
<b>Last Updated</b>	Displays the date when the application status was updated.
 <b>Employee Referral</b>	<p>The Employee Referral icon appears if the referral source on the application indicates that the applicant was referred by an employee (that is, the referral source is a recruitment source with type <i>Employee</i>).</p> <p>If none of the applicants in the grid were referred by employees, this column is hidden entirely.</p>
 <b>Former Employee</b>	<p>The Former Employee icon appears if the applicant identifies himself as a former employee when applying for the job.</p> <p>If none of the applicants in the grid are former employees, then this column is hidden.</p>
<b>Veteran</b>	<p>Displays <i>Yes</i> if the applicant identifies himself as a veteran when applying for the job.</p> <p>If none of the applicants in the grid are veterans, then this column is hidden.</p>
<b>Military Status</b>	<p>Displays the military status if the applicant is a veteran.</p> <p>If none of the applicants in the grid are veterans, then this column is hidden.</p>
 <b>Application</b>	Click to access the <a href="#">Manage Application Page</a> , where you can review and manage activity related to a single applicant for a single job opening.
 <b>Resume</b>	<p>Click to open a new window that displays the applicant's resume.</p> <ul style="list-style-type: none"> <li>• If the resume is an attachment, the file opens in the new window.</li> <li>• If the resume was entered into the <b>Resume Text</b> field in the application, the new window displays the <a href="#">Applicant Resume Page</a>.</li> <li>• If no resume exists for a particular applicant, then this column is blank.</li> </ul> <p>If none of the applicants in the grid have resumes, the entire Resume column is hidden.</p>

<b>Field or Control</b>	<b>Description</b>
<p><b>References</b></p>	<p>Displays <i>Yes</i> if the applicant provided references while applying for the job. Click <i>Yes</i> to go the <a href="#">Manage Applicant page: Applicant Data Tab</a> and view the reference details.</p>
<p> <b>Interest</b></p>	<p>This column appears only if the <b>Display Interest Indicator</b> field on the <a href="#">Recruiting Installation – Applicants Page</a> is set to <i>Yes</i>.</p> <p>Click the first, second, or third star on the interest widget to indicate the level of interest in this applicant for the current job opening. The stars up to and including the one you click change to solid yellow to provide a visual indication of your interest level.</p> <p>Click the <i>x</i> to clear the rating. All three stars turn gray.</p> <p>The interest level for an applicant is specific to the job opening. It is not, however, user-specific, so your selection is global and can be seen and changed by other users.</p> <p>Interest level is available as a search field on the <a href="#">Search Applications Page</a>, where it also appears in the search results grid.</p>
<p> <b>Mark Reviewed</b></p>	<p>Click to update the applicant’s disposition to <i>020 - Reviewed</i>. Because this action always uses the disposition with status code 020, you should not modify this delivered disposition.</p> <p>This action is not controlled by flexible processing and is therefore always available.</p>
<p> <b>Route</b></p>	<p>Click to perform the Route Applicant action.</p> <p>If the applicant has at least one existing routing for this job opening, this action displays the <a href="#">Manage Routings Page</a>. If the applicant does not yet have any routings, this action displays the <a href="#">Route Applicant Page</a>.</p>
<p> <b>Interview</b></p>	<p>Click to perform the Manage Interviews action.</p> <p>If the applicant has at least one existing interview for this job opening, , this action displays the <a href="#">Manage Interviews Page</a>. If the applicant does not yet have any interviews, this action displays the <a href="#">Interview Schedule Page</a>.</p>
<p> <b>Reject</b></p>	<p>Click to perform the Reject Applicant action, which displays the <a href="#">Reject Applicant Page</a>.</p>



<b><i>Field or Control</i></b>	<b><i>Description</i></b>
 <b>Print Application Details</b>	Click to access the <a href="#">Application Report Options Page</a> , where you can choose report parameters and then generate an application details report.

<b>Field or Control</b>	<b>Description</b>
<p><b>Other Actions</b></p>	<p>Click to display a menu of additional actions that you can perform for the applicant shown in the row. The actions appear under two sub-menus.</p> <p>Under the Recruiting Actions sub-menu, you can choose these actions:</p> <ul style="list-style-type: none"> <li>• Create Interview Evaluation</li> <li>• Create Salary Package Model</li> </ul> <p>This action is available only to recruiting administrators, and only if PeopleSoft Global Payroll for Australia is installed.</p> <ul style="list-style-type: none"> <li>• Prepare Job Offer</li> <li>• Accept Offer</li> </ul> <p>This action is available only if there is an offer in the default open status.</p> <ul style="list-style-type: none"> <li>• Reject Offer</li> </ul> <p>This action is available only if there is an offer in the default open status.</p> <ul style="list-style-type: none"> <li>• Withdraw Application</li> </ul> <p>This action is available only if disposition <i>130 Withdrawn Application</i> is configured as a successor of the current disposition.</p> <ul style="list-style-type: none"> <li>• Prepare for Hire</li> </ul> <p>This action is available only if the current disposition is <i>071 - Offer Accepted</i>, <i>080 - Ready to Hire</i>, or <i>090 - Hired 120 - Withdrawn</i>.</p> <ul style="list-style-type: none"> <li>• Withdraw from Hire</li> </ul> <p>This action is available only if the current disposition is <i>080 - Ready to Hire</i>.</p> <ul style="list-style-type: none"> <li>• Edit Application Details</li> <li>• Edit Disposition</li> </ul> <p>If a flexible recruiting process governs the job opening, this is available only if the process provides the user with valid transitions from the current disposition.</p>

<b>Field or Control</b>	<b>Description</b>
	<p>Under the Applicant Actions sub-menu, you can choose these actions:</p> <ul style="list-style-type: none"> <li>• Add Applicant Note</li> <li>• Add Applicant to List</li> <li>• Change Applicant Status</li> <li>• Copy Salary Package</li> </ul> <p>This action is available only to recruiting administrators, and only if PeopleSoft Global Payroll for Australia is installed and the applicant's disposition is <i>Hired</i>.</p> <ul style="list-style-type: none"> <li>• Forward Applicant</li> <li>• Link Applicant to Job</li> <li>• Manage Applicant Checklists</li> <li>• Manage Applicant Contracts</li> <li>• Pre-Employment Check</li> <li>• Send Correspondence</li> </ul> <p>See <a href="#">Understanding Actions for Managing Applicants</a>.</p>

## Configuring the Columns in the Applicants Grid

Follow these steps to hide or relabel the columns in the applicants grid:

1. Navigate to **Enterprise Components > Page and Field Configuration > Page and Field Configurator** and add a new value with component name *HRS\_JO\_360*, Market *Global*, and Configuration Type *Standard*. Enter description as *Manage Job Openings*.
2. Select **Select Fields** and choose the fields that you wish to hide or relabel. Select the check box under **Hide Field** column for the fields you want to hide from the Applicants grid. You can also relabel the fields by selecting the check box under **Modify Label** column and entering the required label. Save the configuration.
3. Under the **Map to Portal Registry** tab, select the row for *EMPLOYEE* and select **Apply Configuration**. You can see that the **Review/Edit Mapping** link is enabled after you apply the configuration.
4. Select **Review/Edit Mapping** to open the Event Mapping Configuration page. Uncheck the **Enabled** field for component with Event Name *PostBuild*.
5. Add a new row under Event Mapping Configuration with the below details and save the page:
  - Event Level: Page

- Page or Record or Record Field: HRS\_JO\_360
- Event Name: Activate
- Service ID/Application Package: Copy the Service ID from the row for component with Event Name *PostBuild*
- Processing Sequence: Post
- Enabled: select the check box

6. Add a new row under Event Mapping Configuration with the below details and save the page:

- Event Level: Rec Field
- Unrestricted Prompt: select the check box
- Record Name: HRS\_JO\_360\_WRK, Field Name: HRS\_FUNNEL\_PHASE
- Event Name: FieldChange
- Service ID/Application Package: Copy the Service ID from the row for component with Event Name *PostBuild*
- Processing Sequence: Post
- Enabled: select the check box

This example illustrates the Event Mapping Configuration for Manage Job Opening page.

Event Mapping Configuration										
Event Mapping Configuration										
Content Reference: Manage Job Opening										
Event Level	Unrestricted Prompt	Page or Record or Record Field	Event Name	Service ID/Application Package	Processing Sequence	Event Map Parameter	Sequence Number	Enabled		
1	Record	<input type="checkbox"/>	HRS_JO_APP_A_YW	RowInsert	E0CC_ROWINSERT1 E0CC_COMP_CONFIG Services CompRecord_RowInsert	Post		<input type="checkbox"/>	<input checked="" type="checkbox"/>	+ -
2	Record	<input type="checkbox"/>	HRS_JO_APP_A_YW	RowInit	E0CC_ROWINIT1 E0CC_COMP_CONFIG Services CompRecord_RowInit	Post		<input type="checkbox"/>	<input checked="" type="checkbox"/>	+ -
3	Component	<input type="checkbox"/>		SavePreChange	E0CC_SAVEPRECHANGE E0CC_COMP_CONFIG Services Component_SavePreChange	Post		<input type="checkbox"/>	<input checked="" type="checkbox"/>	+ -
4	Component	<input type="checkbox"/>		PostBuild	E0CC_POSTBUILD E0CC_COMP_CONFIG Services Component_PostBuild	Post		<input type="checkbox"/>	<input type="checkbox"/>	+ -
5	Page	<input type="checkbox"/>	HRS_JO_360	Activate	E0CC_POSTBUILD E0CC_COMP_CONFIG Services Component_PostBuild	Post		<input type="checkbox"/>	<input checked="" type="checkbox"/>	+ -
6	Rec Field	<input checked="" type="checkbox"/>	HRS_JO_360_WRK HRS_FUNNEL_PHASE	FieldChange	E0CC_POSTBUILD E0CC_COMP_CONFIG Services Component_PostBuild	Post		<input type="checkbox"/>	<input checked="" type="checkbox"/>	+ -

## Group Action

**Note:** The number of rows that can be included in a group action can be limited using the Group Action Limit field on the Recruiting Installation – Applicants Page. If a user attempts to perform a group action when too many rows are selected, the system displays a message informing the user of the limit.

<b><i>Field or Control</i></b>	<b><i>Description</i></b>
<b>Select All and Deselect All</b>	Use these links to select or deselect grid rows so that you can perform group actions on the selected rows.

<b>Field or Control</b>	<b>Description</b>
<p><b>Group Action</b></p>	<p>Click to display a menu of group actions that you can perform for the selected applicants. The actions appear under two sub-menus.</p> <p>Under the Recruiting Actions sub-menu, you can choose these actions:</p> <ul style="list-style-type: none"> <li>• Mark Reviewed</li> <li>• Manage Interviews</li> <li>• Create Interview Evaluations</li> <li>• Reject Applicant</li> <li>• Route Applicant</li> <li>• Withdraw Application</li> <li>• Edit Application Details</li> <li>• Print Applications</li> </ul> <p>Under the Applicant Actions sub-menu, you can choose these actions:</p> <ul style="list-style-type: none"> <li>• Add Applicant to List</li> <li>• Change Applicant Status</li> <li>• Forward Applicant</li> <li>• Link Applicant to Job</li> <li>• Merge Applicant (multiple applicants must be selected)</li> <li>• Send Correspondence</li> </ul> <p>See <a href="#">Understanding Actions for Managing Applicants</a>.</p> <hr/> <p><b>Note:</b> The number of rows that can be included in a group action can be limited using the Group Action Limit field on the <a href="#">Recruiting Installation – Applicants Page</a>. If a user attempts to perform a group action when too many rows are selected, the system displays a message informing the user of the limit and stating that only the allowed number of rows will be processed. If the user continues, the system processes the allowed number of rows, starting at the beginning of the list and following the grid sort order. Even if the user cancels, the system deselects all rows after the specified limit, and the user can review which rows will be processed before re-initiating the action with an allowable number of selected rows.</p> <hr/>

## Manage Job Opening Page: Applicant Search Tab

Use the Manage Job Opening page: Applicant Search tab (HRS\_REC\_SCHAPP) to search for applicants for the job opening.

**Note:** The Applicant Search tab on the Manage Job Opening page is actually the Search Applicants Page rendered in the context of the Manage Job Opening page. This tab is visible only to users who have security access to the Search Applicants page.

Navigation:

Access the Manage Job Opening Page, then click the Applicant Search tab.

This example illustrates the Manage Job Opening page: Search Job Openings tab. In this example, the Saved Compliance & Automatch Searches section is displayed. The other sections (Quick Search, Keyword Search, Advanced Search, and Profile Match) are identical to their counterparts on the Search Applicants page.

**Manage Job Opening**

Return | Recruiting Home | Search Job Openings | Create New | Clone | Add Note | Interviews | No Category | Print Job Opening Personalize

**Job Opening ID** 505012 **Status** 010 Open  
**Job Posting Title** Assistant Manager **Business Unit** GBIBU (Global Business Institute BU)  
**Job Code** 170030 (Assistant-Management Staff) **Department** 13000 (Finance and Administration)  
**Position Number** 19000005 (Management - Staff Assistant) **Job Family** KADMIN (Administrative Support)  
**Post Date** 09/11/2021 **Remove Date** 29/03/2024  
**Next Review Date** 15/03/2024

Applicants **Applicant Search** Applicant Screening Activity & Attachments Details

Quick Search | Keyword Search | Advanced Search | Profile Match | Saved Compliance & Automatch Searches

\*Use Saved Search

**Search Criteria**

Search

Search My Applicants

Find Applicants Matching

Application Date Range  to

Job Family  Administrative Support

Recruiting Location

Country

State

City

Referral Source

Referral SubSource

Keywords  [Search Tips](#)

**Applicant Type**

External Applicant  
 Employee  
 Non-Employee

**Exclude Applicant Status from Search**

010 Active  
 020 Hired  
 030 Inactive  
 040 Queued

## Search Sections

<i>Field or Control</i>	<i>Description</i>
<p><b>Quick Search, Keyword Search, Advanced Search, and Profile Match</b></p>	<p>These sections are identical to the search options on the <a href="#">Search Applicants Page</a>.</p> <p>The search results in these sections provide access to the same actions (and group actions) that are available when you search applicants outside the context of a job opening.</p> <p>Note that if you perform the Link Applicant to Job action from the context of a job opening, the current job opening ID is the default job opening for the link action.</p>

## Saved Compliance and Automatch Searches

The Saved Searches & Automatches section renders the [Saved Searches Page](#) within the context of the job opening. In this context, the grid shows only the saved searches that are associated with the current job opening (and therefore doesn't include the column that normally identifies the associated job opening).

Searches are associated with a job opening only if the job opening ID is part of the search criteria. It is not relevant whether the search is saved from the stand-alone Search Applicants page or from the context of the job opening.

The same grid also appears on the [Manage Job Opening Page: Activity & Attachments Tab](#)

## Manage Job Opening Page: Applicant Screening Tab

Use the Manage Job Opening page: Applicant Screening tab (HRS\_JO\_SCR\_LVL) to run screening processes.

---

**Note:** This tab is visible only if the user has security access to screening pages and if the job opening has at least one standard screening level (a screening level that is not for prescreening or online screening).

---

Navigation:

Access the [Manage Job Opening Page](#), then click the Applicant Screening tab.



This example illustrates the Manage Job Opening page: Applicant Screening tab.

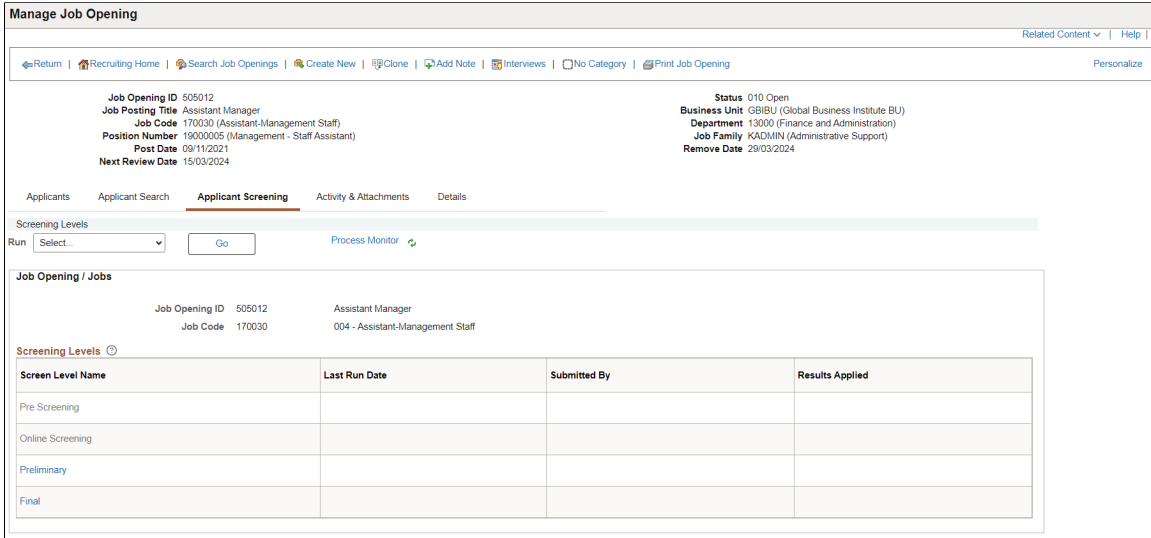

**Note:** For detailed information about screening applicants, see [Running Screening Levels and Applying Results](#)

<b>Field or Control</b>	<b>Description</b>
<b>Screening Level</b>	<p>This section displays summary information about the job opening’s screening levels. If the job opening has multiple job codes, you can scroll to see the screening levels for each job code.</p> <p>For detailed information, see <a href="#">Manage Job Opening Page: Applicant Screening Tab: Screening Level Section</a></p>
<b>Screening Results</b>	<p>This section is available only if screening results exist, either because applicants have undergone prescreening or online screening, or because a recruiting user has run a standard screening level.</p> <p>The Screening Results section lists all screening levels that have results and provides summary statistics about the applicants who were processed. You can select any screening level to see a complete list of applicants who were processed, along with results for each applicant.</p> <p>For detailed information, see <a href="#">Manage Job Opening Page: Applicant Screening Tab: Screening Results Section</a></p>

## Manage Job Opening Page: Activity & Attachments Tab

Use the Manage Job Opening page: Activity & Attachments tab page (HRS\_JO\_360) to review job status history, notes, attachments, expenses, and saved results from applicant searches.

Navigation:

Access the [Manage Job Opening Page](#), then click the Activity & Attachments tab.

This example illustrates the Manage Job Opening page: Activity & Attachments tab.

Related Content ▾
Save | [Return](#) | [Recruiting Home](#) | [Search Job Openings](#) | [Create New](#) | [Clone](#) | [Add Note](#) | [Interviews](#) | [No Category](#) | [Print Job Opening](#)

<b>Job Opening ID</b> 505012 <b>Job Posting Title</b> Assistant Manager <b>Job Code</b> 170030 (Assistant-Management Staff) <b>Position Number</b> 19000005 (Management - Staff Assistant) <b>Post Date</b> 09/11/2021 <b>Next Review Date</b> 15/03/2024	<b>Status</b> 010 Open <b>Business Unit</b> GBIBU (Global Business Institute BU) <b>Department</b> 13000 (Finance and Administration) <b>Job Family</b> KADMIN (Administrative Support) <b>Remove Date</b> 29/03/2024
--	---

Applicants
Applicant Search
Applicant Screening
Activity & Attachments
Details

**Job History** ⓘ

Date	Subject	Reason	Action Taken By
09/11/2021	010 Open		Betty Locherty

**Searches** ⓘ

No searches are related to this Job Opening.

**Notes**

No notes have been added to this Job Opening.

[Add Note](#)

**Attachments**

No Attachments have been added to this Job Opening.

[Add Attachment](#)

**Expenses**

No Expenses have been added to this Job Opening.

## Job History

This grid provides a status history of the job opening.

<b>Field or Control</b>	<b>Description</b>
<b>Date</b>	Displays the date the status was assigned.
<b>Subject</b>	Displays the status description.
<b>Reason</b>	Displays the status reason, if one was supplied when the status was assigned.
<b>Action Taken By</b>	Displays the name of the person whose action updated the status.

## Saved Compliance & Automatch Searches

This grid renders the [Saved Searches Page](#) within the context of the job opening. In this context, the grid shows only the saved searches that are associated with the current job opening (and therefore doesn't include the column that normally identifies the associated job opening).



Searches are associated with a job opening only if the job opening ID is part of the search criteria. It is not relevant whether the search is saved from the stand-alone Search Applicants page or from the context of the job opening.

The same grid also appears on the [Manage Job Opening Page: Applicant Search Tab](#).

## Notes

This grid displays a list of notes related to the job opening.

**Note:** The audience for the note determines which users can access note details. The audience is set on the Job Opening Notes detail page and is not visible in this grid.

<b>Field or Control</b>	<b>Description</b>
<b>Subject</b>	Displays the subject of the note.
<b>Note Date</b>	Displays the date that the note was created.
<b>Author</b>	Displays the name of the person who created the note. If the note is private, only the author can access the note details.
 <b>Edit</b>	<p>Click to access the note details on the <a href="#">Job Opening Notes Page</a>. The note audience determines which users can access or edit note details:</p> <ul style="list-style-type: none"> <li>• If the note audience is <i>Public</i>, all users can access and edit the note details, but only the author or administrator can change the audience.</li> <li>• If the note audience is <i>Interview</i>, all users can access the details, but only the note author or an administrator can edit the details.</li> <li>• If the note audience is <i>Private</i>, only the note author and administrators can access the note details, and this icon is hidden for all other users.</li> </ul>
 <b>Delete</b>	Regardless of the note audience, the only users who can delete a note are the author or an administrator.
<b>Add Note</b>	Click to display the Job Opening Notes page and enter a new note.

## Attachments

This grid displays a list of attachments related to the job opening.

<b>Field or Control</b>	<b>Description</b>
<b>File Name</b>	<p>Displays the file name of the attachment:</p> <ul style="list-style-type: none"> <li>• If the attachment audience is <i>Public</i> or <i>Interview</i>, any user can click the file name to open the attachment.</li> <li>• If the attachment audience is <i>Private</i>, the link is active only for the person who uploaded the attachment and for administrators.</li> </ul>
<b>Description</b>	<p>Enter a description for the attachment:</p> <ul style="list-style-type: none"> <li>• If the attachment audience is <i>Public</i>, any user can enter or modify a description for the attachment.</li> <li>• If the attachment audience is <i>Interview</i> or <i>Private</i>, then only the person who uploaded the attachment and administrators can enter or modify the description.</li> </ul>
<b>Audience</b>	<p>The audience controls access to the attachment:</p> <ul style="list-style-type: none"> <li>• If the audience is <i>Public</i>, then anyone with access to the job opening can view the attached file or modify the description.</li> <li>• If the audience is <i>Interview</i>, then anyone with access to the job opening can view the attached file, but only the person who uploaded the attachment and administrators can modify the description.</li> <li>• If the audience is <i>Private</i> these privileges are limited to the person who uploaded the attachment and to administrators.</li> </ul> <p>Regardless of the audience, the person who uploaded the attachment and administrators are the only users who can delete attachments and modify the attachment audience.</p> <p>Interview attachments don't automatically appear on the Interview Schedule page, but the Interview Schedule page provides links that enable you to copy Interview attachments from the job opening to the interview.</p>
<b>Updated</b>	<p>Displays the date and time that the attachment information was last updated.</p>
<b>Uploaded By</b>	<p>Displays the name of the user who uploaded the attachment.</p>

<i>Field or Control</i>	<i>Description</i>
<b>Add Attachment</b>	Click to display the File Attachment dialog box and upload a new attachment.

## Expenses

This grid displays a list of expenses associated with the job opening.

<i>Field or Control</i>	<i>Description</i>
<b>Expense</b>	Displays the value from the Expense Code field on the Add Expenses page.
<b>Amount, Currency, and Date</b>	These fields show the amount and date of the expense.
<b>Display Name</b>	If the expense is associated with an applicant, this field displays the applicant's name.
<b>Expense Details</b>	Click to display the Add Expenses page and view the detailed information of the expense.
<b>Add Expense</b>	Click to display the Add Expenses page, where you can add a new job opening related expense.

## Job Opening Notes Page

Use the Job Opening Notes page (HRS\_JO\_NOTE\_SEC) to add or edit a job opening note.

Navigation:

- On the Manage Job Opening page: Activity & Attachments tab, click the **Add Note** button or click the Edit icon for an existing note.
- Click the **Add Note** toolbar button on the Manage Job Opening page.

This example illustrates the Job Opening Notes page.

×
Job Opening Notes

**Note Date**

**\*Subject**

**Details**

**\*Audience**

[Help](#)

Add Note

Cancel

<i><b>Field or Control</b></i>	<i><b>Description</b></i>
<b>Note Date</b>	Enter a date for the note.
<b>Audience</b>	<p>Select the audience for this note. Valid options are:</p> <ul style="list-style-type: none"> <li>• <i>Public</i>: Public notes can be viewed and edited by anyone who has access to the job opening.</li> <li>• <i>Interview</i>: Interview notes can be viewed by anyone who has access to the job opening, but only the note author or an administrator can modify the note. Interview notes don't automatically appear in on the Interview Schedule page, but the Interview Schedule page provides links that enable you to copy Interview notes from the job opening to the interview.</li> <li>• <i>Private</i>: The subject of a private note can be viewed by anyone who has access to the job opening, but only the note author or an administrator can view or modify the note details.</li> </ul> <hr/> <p><b>Note:</b> Only the note author or an administrator can modify the audience for an existing note.</p>
<b>Subject</b>	Enter the note subject. The subject is visible to everyone with access to the job opening.
<b>Details</b>	Enter the note details. Details for private notes are visible only to the creator of the note.

## Add Expenses Page

Use the Add Expenses page (HRS\_JO\_EXPENSE\_SEC) to add an expense to a job opening.

Navigation:

Click the **Add Expense** link on the Manage Job Opening page: Activity & Attachments tab, or click the Expense Details link for an existing expense.

This example illustrates the Add Expenses page.

Add Expenses ✕

[Help](#)

Job Opening ID 505012

**Add new Expense**

\*Expense Code

USD

\*Expense Amount

USD

\*Charge Date

Business Unit

Global Business Institute BU

Department

Finance and Administration

Applicant Name

Description

OK

Cancel

<b>Field or Control</b>	<b>Description</b>
<b>Expense Code</b>	Select the expense code. The available values are the same as those for recording employee expenses on the “Employee business expenses Page” (PeopleSoft Human Resources Administer Workforce). These values come from the translate table. To modify the list of expense codes, update the translate table values for the field EXPENSE_CD.
<b>Expense Amount</b>	Enter the amount of the expense.
<b>Charge Date</b>	Enter the date the expense was incurred.
<b>Business Unit</b>	Select the business unit. The default is the business unit that is associated with the job opening.
<b>Department</b>	Select the department. The default is the department that is associated with the job opening.

<b>Field or Control</b>	<b>Description</b>
<b>Applicant Name</b>	Enter the applicant name if the expense is associated with a specific applicant.
<b>Description</b>	Enter a description of this expense.

## Manage Job Opening Page: Details Tab

Use the Manage Job Opening page: Details tab (HRS\_JOB\_OPENING) to review or edit job opening data, including job information, job qualifications, screening settings, postings, and hiring team members.

**Note:** The Details tab on the Manage Job Opening page is actually the Job Opening Page rendered in the context of the Manage Job Opening page.

Navigation:

Access the Manage Job Opening Page, then click the Details tab.

This example illustrates the Manage Job Opening page: Details tab.

**Manage Job Opening**

---

[Return](#) | [Recruiting Home](#) | [Search Job Openings](#) | [Create New](#) | [Clone](#) | [Add Note](#) | [Interviews](#) | [No Category](#) | [Print Job Opening](#)

---

**Job Opening ID** 505012

**Job Posting Title** Assistant Manager

**Job Code** 170030 (Assistant-Management Staff)

**Position Number** 19000005 (Management - Staff Assistant)

**Post Date** 09/11/2021

**Next Review Date** 15/03/2024

**Status** 010 Open

**Business Unit** GBIBU (Global Business Institute BU)

**Department** 13000 (Finance and Administration)

**Job Family** KADMIN (Administrative Support)

**Remove Date** 29/03/2024

---

Applicants
Applicant Search
Applicant Screening
Activity & Attachments
Details

---

Job Details
Qualifications
Screening
Job Postings
Hiring Team

---

**Opening Information** ⌵

---

\*Template ID   Requisition Default

Job Opening Type Standard Requisition

Created By   Betty Locherty

Created

---

\*Openings to Fill

Target Openings

Available Openings

---

Establishment ID   Global Business Institute HQ

Business Unit   Global Business Institute BU

Company   Global Business Institute

This tab provides access to the same job opening data that was shown on the Job Opening Page when the opening was initially created. In both cases, the layout and content of the page come from the job opening template.



## Categorizing Job Openings

This topic discusses how to categorize job openings using personalized categories.

**Note:** Categories are a personal organizational tool. Users choose their own category names, and users do not see how other users have categorized job openings.

### Pages Used to Categorize Job Openings

<i>Page Name</i>	<i>Definition Name</i>	<i>Usage</i>
<a href="#">My Job Categories Page</a>	HRS_JOB CAT_PICKER	Choose a personal category for a job opening.
<a href="#">Personalize Job Categories Page</a>	HRS_JO_CATG_OPR	Personalize job category labels and category sort order.

### My Job Categories Page

Use the My Job Categories page (HRS\_JOB CAT\_PICKER) to assign a personal category to a job opening.

Navigation:

Click the **Category** icon for a job opening. This icon appears on the following pages:

- [Manage Job Opening Page](#) (on the toolbar)
- [Search Job Openings Page](#)
- [Browse Job Openings Page](#)
- [My Job Openings Pagelet](#)

This example illustrates the My Job Categories page.

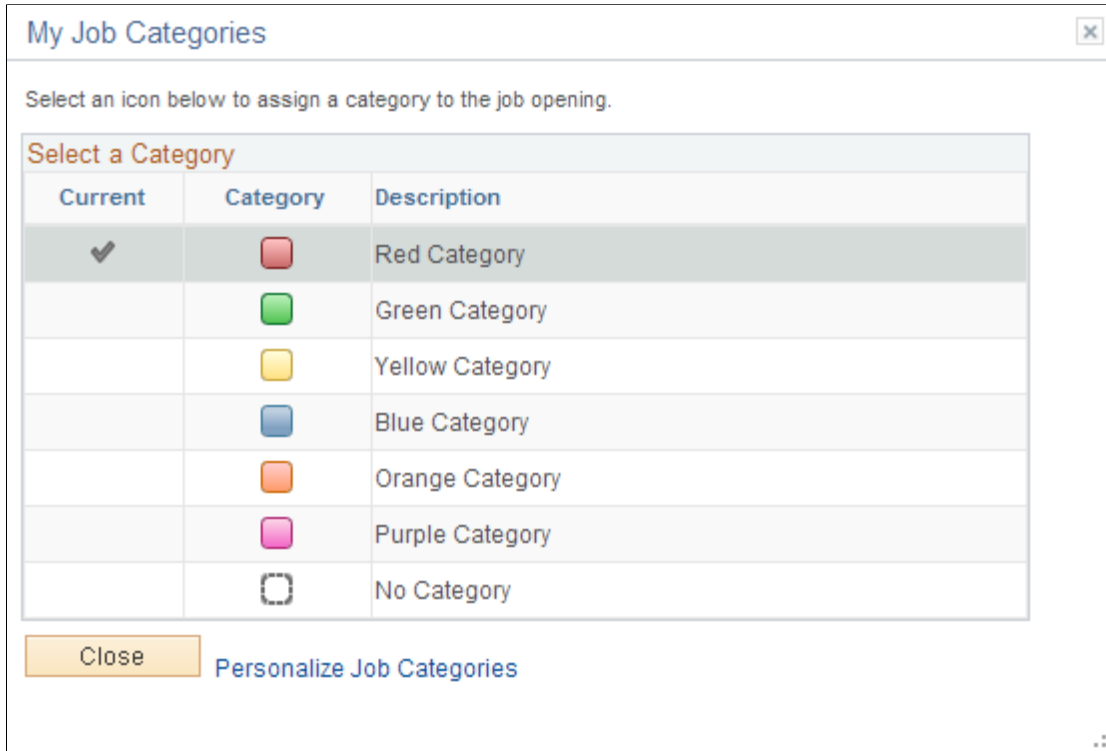

<b>Field or Control</b>	<b>Description</b>
<b>Current</b>	Displays a check mark next to the job opening’s current category. If the current category is inactive (based on settings on the Personalize Job Categories page), the <b>Current</b> column is hidden, and the page displays a message that the current category is inactive.
<b>Category</b>	Click the icon for the category that you want to assign to the current job opening. The system immediately assigns the category and closes this page.  The six categories are represented square icons with different colors. The icon for no category is a transparent square with a dotted line border.
<b>Description</b>	Displays the name of each category.
<b>Close</b>	Click to close the page without changing the category of the current job opening.
<b>Personalize Job Categories</b>	Click to access the Personalize Job Categories page, where you can modify category names (but not icons) and you can set the category sort order.

## Personalize Job Categories Page

Use the Personalize Job Categories page (HRS\_JO\_CATG\_OPR) to personalize job category labels and category sort order.

Navigation:

Click the **Personalize Job Categories** link on the My Job Categories Page.

This example illustrates the Personalize Job Categories page.

Category	*Priority	Status	*Description
	1	Active	Red Category
	2	Active	Green Category
	3	Active	Yellow Category
	4	Active	Blue Category
	5	Active	Orange Category
	6	Active	Purple Category
			No Category

OK Cancel Apply

<b>Field or Control</b>	<b>Description</b>
<b>Category</b>	Displays the category icon.
<b>Priority</b>	Enter sequence numbers to set the category order. This controls the category order on the My Job Categories page. Also, the grids on the Search Job Openings page and on the My Job Openings pagelet include a sortable column for the job opening category, and the sort order reflects the priority assigned here.
<b>Status</b>	Select <i>Active</i> to make the category available on the My Job Categories page so that you can assign the category to job openings. Select <i>Inactive</i> to remove the category from the My Job Categories page.  Inactivating a category does not affect job openings that already have that category, and the category remains available as search criteria on the Search Job Openings page.

<i>Field or Control</i>	<i>Description</i>
<b>Description</b>	Enter a personalized descriptive name for each category. The delivered category names simply identify the color of the associated icon (for example, <i>Red Category</i> ).

## Printing Job Openings

This topic provides an overview of job opening printing and discusses how to print the a report with job opening details.

### Page Used to Print Job Openings

<i>Page Name</i>	<i>Definition Name</i>	<i>Usage</i>
Select Job Opening Sections Page	HRS_JO_PRNT_SECT	Generate the Job Opening report (HRS_BIP_JOBP), which includes detailed information for a single job opening.

## Understanding Job Opening Printing

The Select Job Opening Sections page enables you to choose which job opening data to print before you generate the Job Opening report.

The sections that are available for selection include:

1. *<PAGE> <Section>*, representing the job opening sections that are defined in the job opening template.

Job opening templates are made up of *pages* and *sections*. Sections are specific data elements such as salary information or competencies. Sections are organized under pages that are rendered as links under the Details tab on the Manage Job Opening page (or as tabs when you are creating a job opening).

When you choose sections for the Job Opening report, the list of available sections uses the format *<PAGE> <Section>*. For example, if the Competencies section for a job opening appears under a Qualifications page, that section appears in the list as *QUALIFICATIONS Competencies*.

**Note:** All sections from the job opening template are always included in the list, regardless of whether there is data to print. However, sections that do not contain any data do not appear in the final report. For example, if the template includes a section for competencies, then competencies appears in the list of available sections. But if a specific job opening doesn't list any competencies, then the report will not have a competencies section at all (rather than having a blank section for competencies).

2. *OTHER Notes*: When this is selected, the report shows public job opening notes as well as any private notes to which the current user has access.

3. *OTHER Applicants*: When this is selected, the report shows the following applicant-related information:
  - a. The [Recruiting Phases Chart](#) for the job opening.
  - b. A list of applicants that shows current dispositions (and when the disposition was assigned).
  - c. The [Received/Rejected Chart](#) for the job opening.
4. *OTHER Expenses*: When this is selected, the report shows the expenses for the job opening.
5. *OTHER Job History*: When this is selected, the report shows the status change history for the job opening.

---

**Note:** The Notes, Applicants, and Expenses sections do not appear in the section list unless there is data to print. For example, the Notes section appears only if you have access to at least one note, as determined by the normal security for public and private notes.

---

## Select Job Opening Sections Page

Use the Select Job Opening Sections page (HRS\_JO\_PRNT\_SECT) to generate the Job Opening report (HRS\_BIP\_JOBP), which includes detailed information for a single job opening.

Navigation:

Click the **Print Job Opening** toolbar button on the [Manage Job Opening Page](#) or the [Job Opening Page](#).

This example illustrates the Select Job Opening Sections page.

< Manage Job Opening
Select Job Opening Sections

Job Opening 900006 Director of Personnel

[Create Report](#)

**Job Opening Print Selection**

1-24 of 24

Select	Section to Print [PAGE.Section]
<input checked="" type="checkbox"/>	JOB DETAILS Job Information
<input checked="" type="checkbox"/>	JOB DETAILS Salary Information
<input checked="" type="checkbox"/>	JOB DETAILS Staffing Information
<input checked="" type="checkbox"/>	QUALIFICATIONS Areas of Study
<input checked="" type="checkbox"/>	QUALIFICATIONS Competencies
<input checked="" type="checkbox"/>	QUALIFICATIONS Degrees
<input checked="" type="checkbox"/>	QUALIFICATIONS Educ and Govt Special Projects
<input checked="" type="checkbox"/>	QUALIFICATIONS Education and Experience
<input checked="" type="checkbox"/>	QUALIFICATIONS Employment Questions
<input checked="" type="checkbox"/>	QUALIFICATIONS Honors and Awards
<input checked="" type="checkbox"/>	QUALIFICATIONS Language Skills
<input checked="" type="checkbox"/>	QUALIFICATIONS Licenses and Certifications
<input checked="" type="checkbox"/>	QUALIFICATIONS Memberships
<input checked="" type="checkbox"/>	QUALIFICATIONS School Education
<input checked="" type="checkbox"/>	QUALIFICATIONS Skills Questions
<input checked="" type="checkbox"/>	QUALIFICATIONS Tests or Examinations
<input checked="" type="checkbox"/>	SCREENING Screening Options
<input checked="" type="checkbox"/>	JOB POSTINGS Job Postings
<input checked="" type="checkbox"/>	HIRING TEAM Hiring Manager Assignments
<input checked="" type="checkbox"/>	HIRING TEAM Interested Party Assignments
<input checked="" type="checkbox"/>	HIRING TEAM Interviewer Assignments
<input checked="" type="checkbox"/>	HIRING TEAM Recruiter Assignments
<input checked="" type="checkbox"/>	HIRING TEAM Screening Notification Team
<input checked="" type="checkbox"/>	OTHER Job History

[Select All](#)     [Deselect All](#)     [Return to Previous Page](#)

[Create Report](#)

## Job Opening Print Selection

<i>Field or Control</i>	<i>Description</i>
Select	Select the check box for the sections that you want to include in your job opening report. The Job Information section is always selected, even if you click the <b>Deselect All</b> link. This ensures that identifying information about the job opening always appears in your report.
Section to Print	Displays a list of sections that are available for printing. The specific sections in the list depend on the job opening.

## Generating the Report

<i>Field or Control</i>	<i>Description</i>
Preview Printable Details	Click this link to create the Job Opening report, which opens in a new browser window. To print the report, use your browser's print command.

---

## Viewing Related Content Charts for Job Openings

This topic discusses the two charts that are delivered as related content for job openings.

### Pages Used to View Related Content Charts for Job Openings

<i>Page Name</i>	<i>Definition Name</i>	<i>Usage</i>
<a href="#">Received/Rejected Chart</a>	HRS_JO_CHART1	View a line chart showing job opening applications received and rejected over time.  In accessible mode, the data appears in a grid rather than a line chart.
<a href="#">Recruiting Phases Chart</a>	HRS_JO_CHART2	View a pie chart showing the number of job opening applicants in each recruiting phase.  In accessible mode, the data appears in a grid rather than a pie chart.

## Understanding Related Content for Job Openings

Charts to help you understand the recruiting activity for a job opening are available as related content from the [Manage Job Opening Page](#).

Access the charts using the Related Content link that appears at the top of the Manage Job Opening page.

This example illustrates the Related Content menu on the Manage Job Opening page.

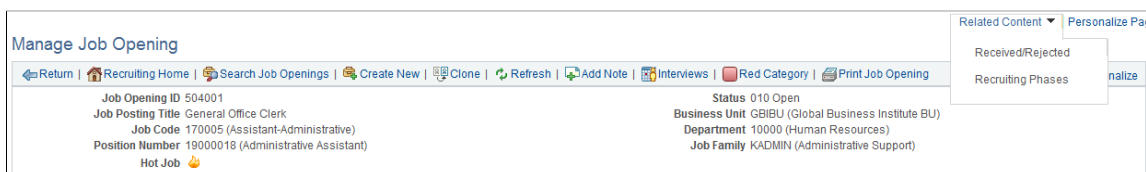

When you select a specific chart from the Related Content menu, the chart appears in the bottom half of a split screen, while top half of the split screen continues to display the job opening.

The related content portion of the split screen displays tabs for each chart so that you can switch charts without returning to the Related Content menu.

## Received/Rejected Chart

Use the Received/Rejected page (HRS\_JO\_CHART1) to view a line chart showing job opening applications received and rejected over time.

Navigation:

On the Manage Job Openings page, select the **Related Content** link, then select **Received/Rejected** from the related content menu.

This example illustrates the Received/Rejected chart.

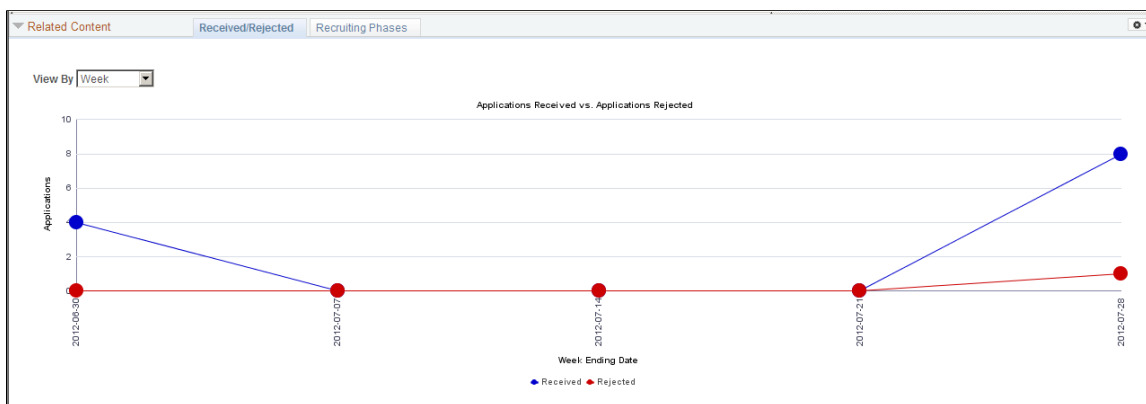

The chart displays dates ranging from the date that the job opening was first linked to an application through the date of the most recent disposition change.

To see the exact number of applicants associated with a data point, place the cursor over the data point to show the mouseover text.



<b>Field or Control</b>	<b>Description</b>
<b>View By</b>	Choose whether to totals by <i>Week</i> or by <i>Month</i> . The chart uses the last day of each time period as the label for the time period. Users can personalize the first day of the week by selecting My Personalizations from the main PeopleSoft menu.
<b>Received</b>	The <b>Received</b> data points show the number of applications that were initially linked to the job opening during the time period. The chart ignores draft application and applications that were linked with status <i>112 - Failed Prescreening</i> , as failing prescreening prevents an applicant from applying for the job opening.
<b>Rejected</b>	The <b>Rejected</b> data points show the number of applications that were moved to the rejected phase during the time period. The chart ignores draft applications and applications that were assigned status <i>112 - Failed Prescreening</i> , as applicants who fail prescreening are not considered to have applied.

## Recruiting Phases Chart

Use the Recruiting Phases page (HRS\_JO\_CHART2) to view a pie chart showing the number of job opening applicants in each recruiting phase.

Navigation:

On the Manage Job Openings page, select the **Related Content** link, then select **Recruiting Phases** from the related content menu.

This example illustrates the Recruiting Phases chart.

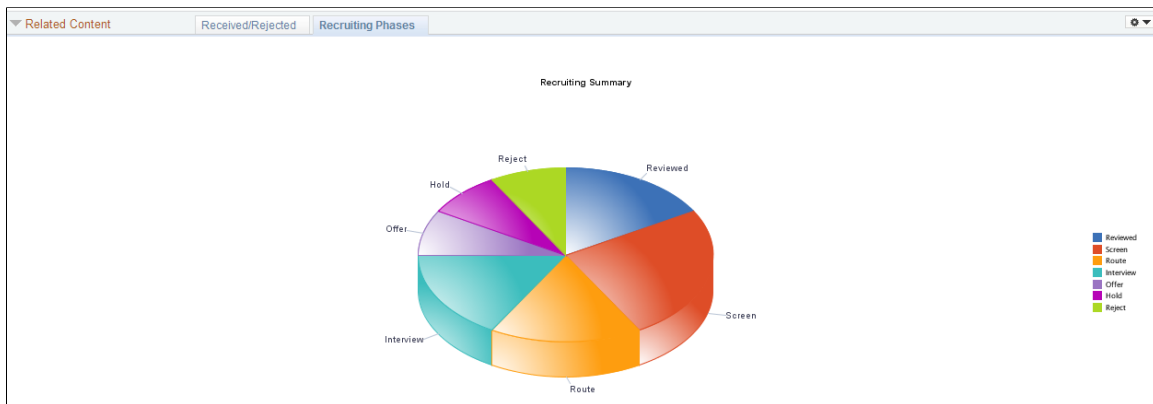

This is a standard pie chart showing the distribution of applicants across recruiting phases. To see the exact number of applicants in a particular phase, place the cursor over the pie segment to show the mouseover text.



## Chapter 18

# Searching for and Managing Job Postings

## Searching for Job Postings

This topic discusses how recruiters can search for job postings. (For information about applicant-facing posting searches, refer to the documentation for PeopleSoft Candidate Gateway.)

**Note:** You must deploy and build the HC\_HRS\_JOB\_POSTING search index before you can use the Search Job Postings page. For information about working with search indexes, see [Understanding Recruiting Search Indexes](#).

## Pages Used to Search for Job Postings

<i>Page Name</i>	<i>Definition Name</i>	<i>Usage</i>
<a href="#">Search Job Postings Page</a>	HRS_REC_SCHJOB	Search for job postings.
<a href="#">View Job Posting Page</a>	HRS_REC_JBPST	View job posting details.

## Search Job Postings Page

Use the Search Job Postings page (HRS\_REC\_SCHJOB) to search for job postings.

Navigation:

**Recruiting > Postings > Search Postings**

This example illustrates the Quick Search tab on the Search Postings page.

The screenshot shows the 'Search Job Postings' interface. At the top, there are navigation links for 'Recruiting Home' and 'Manage Job Postings'. Below this, there are two tabs: 'Quick Search' (selected) and 'Advanced Search'. The 'Search Criteria' section includes a 'Search For' field with the text 'billing', a 'Search Tips' link, and a 'Posted Within' dropdown menu set to 'Anytime'. There are 'Search' and 'Clear' buttons. Below the search criteria, it indicates '2 Results Found'. The 'Search Results' section shows a table with columns for 'Job Posting Title', 'Job ID', 'Posting Type', 'Recruiting Location', and 'Hiring Manager'. The results are as follows:

Job Posting Title	Job ID	Posting Type	Recruiting Location	Hiring Manager
<a href="#">Billing Manager - Medical Claims</a>	504024	Internal Posting	Corporation Headquarters	Rosanna Channing
<a href="#">Billing Manager - Medical Claims</a>	504024	External Posting	Corporation Headquarters	Rosanna Channing

This example illustrates the Advanced Search tab on the Search Postings page.

**Search Job Postings**

[Recruiting Home](#) | [Manage Job Postings](#)

[Quick Search](#) | **[Advanced Search](#)**

**Search Criteria**

Keywords  [Search Tips](#)  
 Posting Type   
 Job Family   
 Posted Within   
 Recruiting Location  [Delaware Operations](#)  
 Country   
 Full/Part Time   
 Regular/Temporary   
 Desired Annual Pay

1 Results Found

**Search Results** [Personalize](#) | [Find](#) | [View All](#) | [Print](#) | [First](#) 1 of 1 [Last](#)

Job Posting Title	Job ID	Posting Type	Recruiting Location	Hiring Manager
Sr Payroll Clerk(Interview)	10279	External Posting	Delaware Operations	

### Toolbar

<i>Field or Control</i>	<i>Description</i>
<b>Recruiting Home</b>	Click to access the <a href="#">Recruiting Home Page</a> .
<b>Manage Job Postings</b>	Click to access the <a href="#">Manage External Postings Page</a> .

### Quick Search Tab: Search Criteria

<i>Field or Control</i>	<i>Description</i>
<b>Search For</b>	Enter search keywords. The system looks for the keywords in the job posting title and the job posting description.

<b>Field or Control</b>	<b>Description</b>
<b>Posted Within</b>	<p>Select a value to restrict the search to jobs that were posted within the specified time period. Values include:</p> <ul style="list-style-type: none"> <li>• <i>Anytime</i></li> <li>• <i>Last Week</i></li> <li>• <i>Last Month</i></li> <li>• <i>Last Three Months</i></li> <li>• <i>Last Year</i></li> </ul>

### Advanced Search Tab: Search Criteria

<b>Field or Control</b>	<b>Description</b>
<b>Keywords</b>	Enter search keywords. The system looks for the keywords across all indexed field, including the posting title, posting description, location, company, business unit, and so forth.
<b>Posting Type</b>	<p>Select a posting type: <i>Contingent Workforce</i>, <i>External Posting</i>, <i>Internal Posting</i>, <i>Labor Office</i>, or <i>Recruitment</i>.</p> <p>When jobs are posted, each posting destination is associated with one of these posting types.</p>
<b>Job Family</b>	Select a job family.
<b>Posted Within</b>	<p>Select a value to restrict the search to jobs that were posted within the specified time period. Values include:</p> <ul style="list-style-type: none"> <li>• <i>Anytime</i></li> <li>• <i>Last Week</i></li> <li>• <i>Last Month</i></li> <li>• <i>Last Three Months</i></li> <li>• <i>Last Year</i></li> </ul>
<b>Recruiting Location</b>	Select a recruiting location to use as search criteria.
<b>Country</b>	Select a country to use as search criteria.

<b><i>Field or Control</i></b>	<b><i>Description</i></b>
<b>Full/Part Time</b>	Select either full-time or part-time as search criteria.
<b>Regular/Temporary</b>	Select either regular or temporary as search criteria.
<b>Desired Annual Pay</b>	Enter the desired annual salary by entering an amount and a currency code. The search returns job postings where the desired amount is within the range specified for the job opening.

## Search Results

**Note:** The search results can include multiple postings for a single job opening. For example, if a job opening is posted both internally and externally, and you do not restrict the search to one posting type, the search results can include both the internal and external posting.

<b><i>Field or Control</i></b>	<b><i>Description</i></b>
<b>Posting Title</b>	Click link to access the View Job Posting Details page.
<b>Job Opening ID</b>	Click link to access the Job Opening page.
<b>Posting Type</b>	Displays the posting type.
<b>Recruiting Location</b>	Displays the primary recruiting location for the job opening.
<b>Hiring Manager</b>	Displays the primary hiring manager for the job opening.

## View Job Posting Page

Use the View Job Posting page (HRS\_REC\_JBPST) to view job posting details.

Navigation:

Click the job posting title link in the search results on the Search Postings page.

This example illustrates the View Job Posting page.

## View Job Posting: Clerk-Payroll(AUS1)

Title Clerk-Payroll(AUS1)

Job Opening ID 300200

Description

Close Date

Location Sydney

Position Nbr 19100019

Full/Part Time

Regular/Temporary

Salary 0 to 0 per

**How To Apply**

*All positions filled through merit promotion procedures by the West Civilian Personnel Operations Center are filled under RESUMIX, an automated ranking and referral system.*

*Only one resume and supplemental data sheet is required for ALL occupational series and locations (up to a combination of 20) for which you indicate interest.*

*West CPOC Resumix application procedures must be followed to receive consideration. Application procedures can be obtained on the West Region Web site at: <http://www.cpoc.army.mil>, then click on Employment Opportunities.*

*You will be instructed to:*

- 1. Prepare a maximum 2 page resume using the Resumix format.*
- 2. Complete the Supplemental Data Sheet.*
- 3. Submit the resume by email or regular mail.*

[Manage Job Postings](#)
[Previous Job Posting](#)
[Next Job Posting](#)
[Job Posting List](#)

The following links appear at the bottom of the page:

### Posting Information

<i>Field or Control</i>	<i>Description</i>
<b>Job Opening ID</b>	Click to access the job opening on the <a href="#">Manage Job Opening Page</a>

## Navigation Links

<i>Field or Control</i>	<i>Description</i>
<b>Manage Job Postings</b>	Click to access the Manage External Postings page.
<b>Previous Job Posting and Next Job Posting</b>	Use these links to navigate to additional posting descriptions from your search results.
<b>Job Posting List</b>	Click to return to your search results on the Search Job Postings page.

## Using the Job Search Agent

This topic provides an overview of the Job Agent (HRS\_JOB\_AGNT) Application Engine process and discusses how to run the Job Agent process.

### Page Used to Run the Job Agent Process

<i>Page Name</i>	<i>Definition Name</i>	<i>Usage</i>
<u>Run Job Search Agent Page</u>	HRS_RUN_JOBAGNT	Run the Job Agent process.

## Understanding the Job Agent Process

Job Agent functionality enables the system to notify applicants of job postings that meet the applicants' saved criteria.

Applicants establish their criteria in Candidate Gateway by saving searches with the criteria for the types of jobs in which they are interested in applying. When the applicant selects the **Notify Me When New Jobs Meet My Criteria** check box, the saved search is processed whenever an administrator runs the Job Agent (HRS\_JOB\_AGNT) process.

During the Job Agent process, the system:

1. Deleted expired job search agents in HRS\_AGNT\_PROF.

The system determines whether the job search agent has expired by taking the date that the job agent was last updated and adding the number of days that you enter in the **Days Job Search Agent Active** field on the Recruiting Installation – Applicants Page. The process compares the resulting date to the system date. If the resulting date is less than the system date, the system deletes the job search agent.

2. Searches for job postings that match the job agent search criteria, and writes the results to a file called HRS\_AGNT\_RSLT.



In addition to meeting the applicant's search criteria, job postings must meet certain general requirements:

- The job opening status is *Open*.
- The posting destination is a *Company* type recruitment source.
- The posting type, *External* or *Internal*, is correct for the applicant who created the job agent.
- There is at least one section of the posting that is visible to the applicant who created the job agent.

Each section of a job posting has a visibility of *Internal Only*, *External Only*, or *Internal and External*.

3. Posts a notification to Candidate Gateway.

Applicants can click on the subject link for the notification to perform the search and see the postings that meet the search criteria.

If the applicant has multiple job search agents, the system posts a separate notification for one.

4. Sends the applicant an email notification using the JobAgentNotification template.

This occurs only if the applicant's contact information includes an email address. The email includes links to the job openings that match the applicant's criteria, up to the maximum number of job openings specified in the **Max Job Posts Per Notification** field on the [Recruiting Installation – Jobs Page](#). If the number of matches exceeds the maximum, the notification email also directs the applicant to visit Candidate Gateway to access complete search results.

## Prerequisites

Enter values for these fields in the Recruiting Installation component:

- Max Job Posts per Notification ([Recruiting Installation – Jobs Page](#)).
- Days Job Search Agent Active and Maximum Job Agents ([Recruiting Installation – Applicants Page](#)).

## Run Job Search Agent Page

Use the Job Search Agent page (HRS\_RUN\_JOBAGNT) to run the Job Agent process.

Navigation:

**Recruiting > Administration > Run Job Search Agent**

This example illustrates the Run Job Search Agent page.

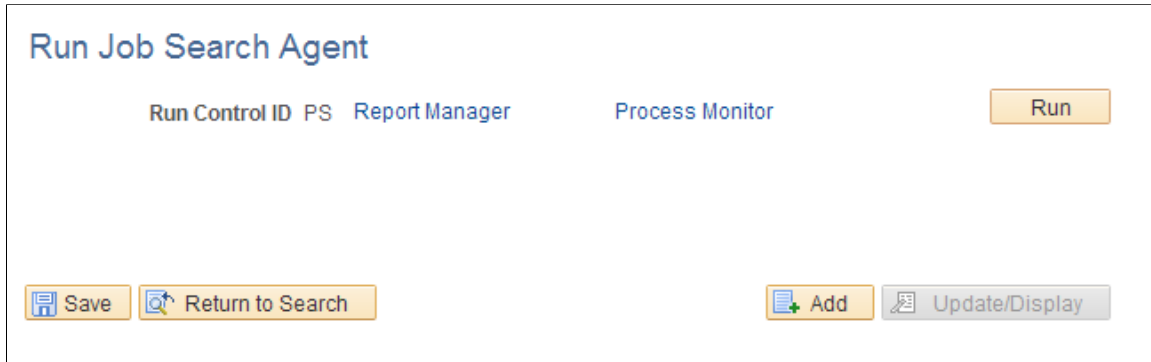

This run control page does not have any parameters.

Click **Run** to access the PeopleSoft Process Scheduler Request page, where you schedule the Job Agent process.

---

**Note:** The best practice is to set up the request so that the Job Agent process runs at regular intervals.

---

## Managing External Job Postings

This topic provides an overview of external job postings and discusses how to manage external job postings.

### Pages Used to Manage External Job Postings

<i>Page Name</i>	<i>Definition Name</i>	<i>Usage</i>
<a href="#">Manage External Postings Page</a>	HRS_EP_STATUS	Post, update, and unpost external job postings.
<a href="#">External Posting History Page</a>	HRS_EP_HISTORY	Review external job posting transactions history.

### Understanding External Job Postings

The Manage External Postings (HRS\_EXTPOST) component enables you to post, update, or unpost job postings from job boards, recruitment agencies, or service procurement providers.

The Manage External Postings component shows only job openings with active postings to third-party job boards. To make a third-party job board available as a posting destination:

1. Use the [Vendor Setup Page](#) to set up the vendor definition for the third-party job board.
2. Use the [Recruitment Sources - Vendor Page](#) to associate a vendor recruitment source with the vendor definition.

Any time you exchange posting data with a vendor, you can review transaction information on the [Integration Log Page](#) .

## Manage External Postings Page

Use the Manage External Postings page (HRS\_EP\_STATUS) to post, update, and unpost external job postings.

Navigation:

**Recruiting > Postings > Manage External Postings > Manage External Postings**

This example illustrates the Manage External Postings page.

### Manage External Postings

[Recruiting Home](#) | 
 [Search Job Postings](#)

**Search Criteria**

Job Opening

Status

Source

Date Type

Start Date  BT

End Date  BT

Data changed since last update

1 Results Found

Select	Job Opening	Source	Status	Post Date	Remove Date	Changed	Action
<input type="checkbox"/>	Assistant-Management Staff-300276	New Job Board	Unconfirmed Post	02/13/2013		No	<input type="text" value=""/> <input type="button" value="Go"/>

Select All Deselect All Group Action

## Search Results

<b>Field or Control</b>	<b>Description</b>
<b>Posting Title</b>	Click the posting title link to access the Job Opening page.

<b>Field or Control</b>	<b>Description</b>
<b>Action</b>	<p>Select the action that you want to send to the destination source and then click <b>Go</b>. Options are:</p> <ul style="list-style-type: none"> <li>• <i>History</i>: Select to access the External Posting History page, where you can review the transactions history for the external job posting.</li> <li>• <i>Post</i>: Sends the post request message. The status of the corresponding job is updated to Unconfirmed Post until the destination responds.</li> <li>• <i>Update</i>: As time goes by, the information associated to posted job openings may change. For example, perhaps the number of openings has increased or decreased. The job board where these jobs are posted are not automatically updated. The update action sends the update request message that will update the job board with the latest posting information. The status of the corresponding posting is not changed.</li> <li>• <i>Unpost</i>: Sends the unpost request message. The status of the corresponding posting is changed to <i>Unconfirmed Unpost</i> until the job board responds.</li> </ul>

## External Posting History Page

Use the External Posting History page (HRS\_EP\_HISTORY) to review external job posting transactions history.

Navigation:

Select *History* from the **Action** column in the **Search Results** group box on the Manage External Postings page.

This example illustrates the External Posting History page.

### External Posting History

Job Opening ID 300276

Posting Title Assistant-Management Staff

Source New Job Board

Status Unconfirmed Post

Post Date 02/13/2013

Remove Date

Transactions <span style="float: right;">Personalize   Find      </span>				
Transaction Name	Result	Description	Last Updated	Integration Log
JobBoardPost	Error	This position has already been posted, please update	02/13/2013 3:05AM	<a href="#">Integration Log</a>
JobBoardUnpost	Success		02/13/2013 3:05AM	<a href="#">Integration Log</a>
JobBoardPost	Success		02/13/2013 3:06AM	<a href="#">Integration Log</a>

Action

## Transactions

<i>Field or Control</i>	<i>Description</i>
<b>Transaction Name</b>	Displays the incoming or outgoing message.
<b>Action</b>	Displays the results of the message.
<b>Description</b>	Displays a description of the action.
<b>Last Updated</b>	Displays the date and time when the outgoing and incoming messages were sent and received.
<b>Integration Log</b>	Click this link to access the Open Integration Framework - Integration Log page, where you can view detailed information about the transaction

---

## Posting Jobs to PeopleSoft Services Procurement

This topic provides an overview of integration with PeopleSoft Services Procurement and discusses how to post jobs to PeopleSoft Services Procurement.

The PeopleSoft Services Procurement documentation provides the technical details of the integration between Talent Acquisition Manager and PeopleSoft Services Procurement. This topic focuses on the business process flow for using PeopleSoft Services Procurement to fill job openings.

## Understanding Integration With PeopleSoft Services Procurement

Oracle delivers prebuilt integration points that enable you to:

- Use PeopleSoft Services Procurement to search for contingent workers to fill job openings in Talent Acquisition Manager.
- Use PeopleSoft Human Resources as your system of record for contingent workers who are brought in to fill PeopleSoft Services Procurement requisitions.

The use of PeopleSoft Human Resources as your system of record for PeopleSoft Services Procurement contingent workers is available regardless of whether you use PeopleSoft Services Procurement to fill Talent Acquisition Manager job openings. This topic, however, discusses the integration that occurs when you use all three systems.

### Integration Process Flow

When you integrate with PeopleSoft Services Procurement, you set up Services Procurement as a posting destination for job openings. Posting a job to Services Procurement initiates this sequence:

1. Talent Acquisition Manager sends the posting data to Services Procurement.
2. Services Procurement uses this data to create a corresponding requisition.
3. When Services Procurement identifies a candidate for the requisition, the candidate information is sent to Talent Acquisition Manager.
4. Talent Acquisition Manager creates an applicant record.

If PeopleSoft Services Procurement previously sent the same candidate to Talent Acquisition Manager, then Talent Acquisition Manager is able to match the candidate information to the existing applicant record. Talent Acquisition Manager does not, however, attempt to match new candidate data to existing applicant records.

5. Talent Acquisition Manager links the candidate's applicant record to the job opening.

The initial disposition for the newly linked applicant is *Offer Accepted*, however, there is no actual offer associated with the applicant. This default disposition ensures that the applicant is ready for hire processing.

When the applicant is linked to a job opening, Talent Acquisition Manager also notifies the recruiter of the newly linked applicant. This notification is in addition to any status change notifications that are active in the system.

6. If the Services Procurement candidate is selected, the recruiter initiates the prepare for hire process in Talent Acquisition Manager.

If a different applicant is hired, the Services Procurement candidate's disposition changes according to the status change rules (for example, to *Reject - Another Applicant Was Hired*), and the system sends a message to Services Procurement canceling the work order.

7. PeopleSoft Human Resources receives a hire request from Talent Acquisition Manager, and the HR user completes the hiring process.

If the applicant is withdrawn from hire (using the *Withdraw from Hire* action in Talent Acquisition Manager), Talent Acquisition Manager sends a Services Procurement indicating that the candidate has been withdrawn and that Services Procurement can cancel the work order.

8. When the hire process is complete, PeopleSoft Human Resources sends employee data (such as the employee ID and record number) back to Talent Acquisition Manger.
9. Talent Acquisition Manager, in turn, sends the employee data to Services Procurement.

When Services Procurement receives the employee data, it sends a request to Human Resources to create a user profile for the new candidate, and Human Resources processes the request and creates the user profile. This occurs because the Human Resources system is considered the core in this integration, and all user profiles must be created in Human Resources and synched to Services Procurement, which requires applicants to have a user profile so that they can sign into Services Procurement to enter time sheets.

10. Services Procurement uses this information to update the work order and to associate the HR employee data with the Service Procurement candidate record.

Having the HR employee data enables Services Procurement to communicate directly with Human Resources when it's time to terminate the employee.

11. When the service provider has completed the project and the work order is closed, terminated, or cancelled, Services Procurement sends a terminate message directly to PeopleSoft Human Resources

This diagram illustrates the process flow for integration between PeopleSoft Talent Acquisition Manager and PeopleSoft Services Procurement

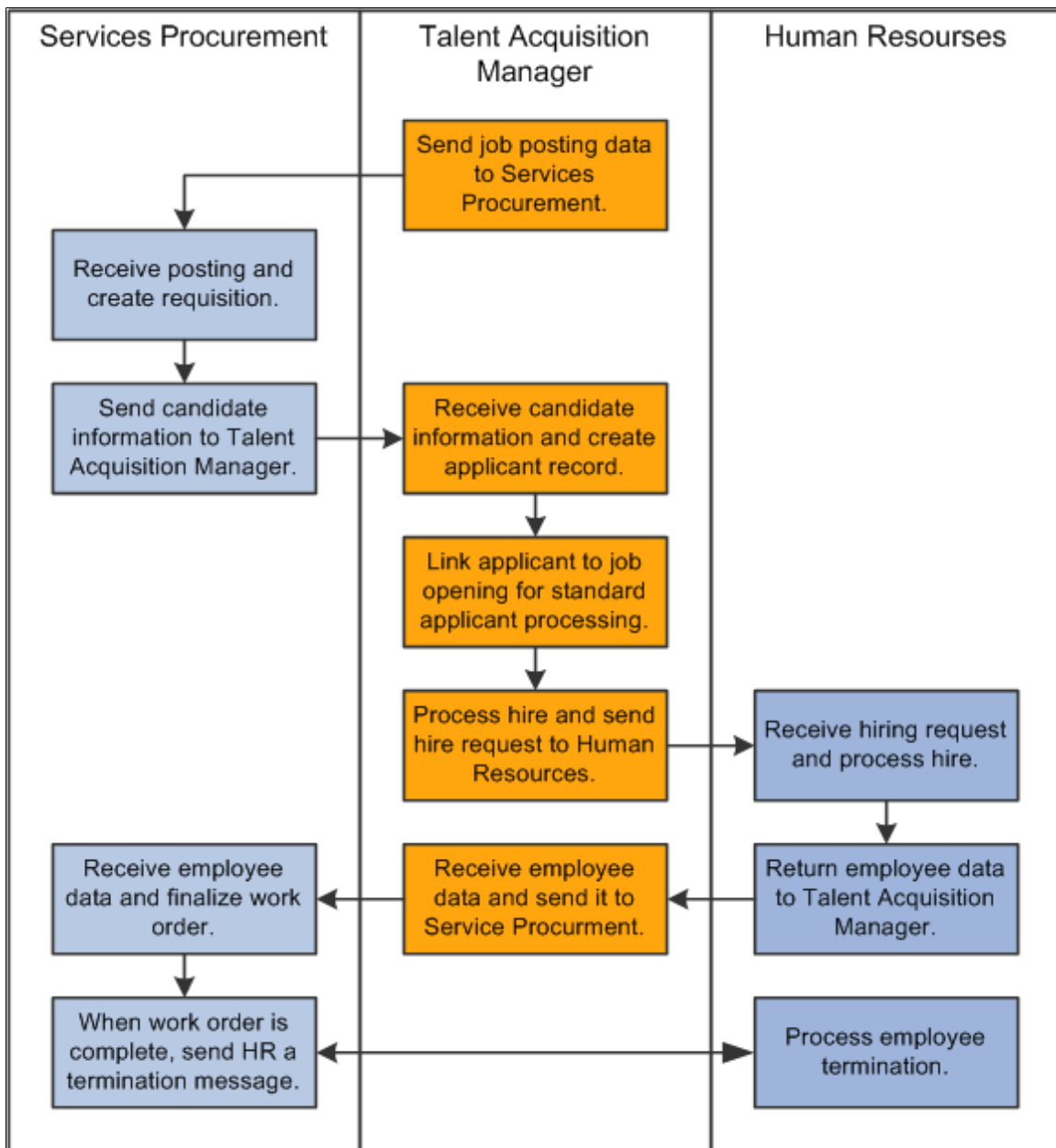

### Data Sent to Services Procurement

When you post a job to PeopleSoft Services Procurement, the message that Talent Acquisition Manager sends to Services Procurement includes (but is not limited to) these data elements:

- A job posting ID that is used as the unique identifier.  
In the Services Procurement system, this ID goes into a field whose name suggests that this is the job opening ID, but it is not the job opening ID.
- The beginning date and ending date of the posting.
- The job family, which is equivalent to the *service type* in PeopleSoft Services Procurement.



- The job code, which is equivalent to the *service* in PeopleSoft Services Procurement.
- The pay frequency for the job openings, which is equivalent to the *unit of measure* in PeopleSoft Services Procurement.

Although this is not a required field in Talent Acquisition Manager, it is required for jobs that are posted to PeopleSoft Services Procurement. If the pay frequency is missing when a user attempts to post the job, the system displays an error.

- The subset of job qualifications (such as competencies and experience) for which there are data mappings to the Services Procurement system.
- The user ID of the person who posted the job.

This user ID *must* also exist in PeopleSoft Services Procurement. This user ID is used to create and immediately display the Services Procurement work order when a job is posted.

## Posting Jobs to PeopleSoft Services Procurement.

To post a job to PeopleSoft Services Procurement:

1. Create a job posting and select *Services Procurement* as the posting destination.

See [Posting Information Page](#).

2. On the Manage External Job Postings page, select the *Post* action for the posting, then click the **Go** button to send the posting message.

The system processes the message and immediately opens the Create Requisition page in PeopleSoft Services Procurement.

See [Managing External Job Postings](#).

3. Review and, if necessary, modify the requisition then submit it.

The recruiting user is responsible for submitting the Services Procurement requisition and therefore must be a user of both systems.

Once the requisition is submitted, the PeopleSoft Services Procurement fulfillment process begins.



# Creating Applicants and Applications

---

## Understanding Applicant Records

This overview discusses:

- Applicant record creation.
- Applicant-related data.

### Applicant Record Creation

There are four ways that applicant records are created in the system:

- Recruiting users manually enter applicant data on the [Create Applicant Page](#).
- Applicants use Candidate Gateway to submit an application.

See “Applying for Jobs” (PeopleSoft Candidate Gateway) and “Using Fluid Candidate Gateway to Apply for Jobs” (PeopleSoft Candidate Gateway).

- Applicants send their resumes to an email address, and a third-party resume reader reads the resume text, converts the text to data, and creates the applicant record.

See [Loading Resumes](#).

- Resumes that are received from third-party staffing suppliers (such as job boards and recruitment agencies) are processed through the Open Integration Framework.

See [Managing Resumes](#).

---

**Note:** Use the [Manage Applicant page: Applicant Data Tab](#) to view and update existing applicant data, regardless of how that data entered the system.

---

### Applicant-Related Data

Applicants are associated with three types of data.

<b>Type of Data</b>	<b>Description</b>
Applicant Data	<p>Applicant data refers to data that remains constant across all of an applicant’s job applications. This includes data such as the applicant’s name, contact information, gender and ethnicity, citizenship, and so forth. The system also treats references as applicant data, which means that applicants are not able to supply different references for different job applications.</p> <p>Applicants use Candidate Gateway to supply this information. In Talent Acquisition Manager, users enter data for a new applicant on the <a href="#">Create Applicant Page</a>. After the record has been saved, users view or update data on the <a href="#">Manage Applicant page: Applicant Data Tab</a>.</p>
Application Data	<p>Application data refers to information that an applicant provides when applying for a job. A single application can be associated with one job opening, many job openings, or no job openings.</p> <p>Application data includes information such as job preferences, work experience, and qualifications.</p> <p>Applicants use Candidate Gateway to supply this information. In Talent Acquisition Manager, users enter application data on the <a href="#">Application Details Page</a>.</p> <p>By default, new applications for applicants include data from previous applications (and, for internal applicants, from the employee’s human resources records). Changes to one application do not affect existing applications.</p> <hr/> <p><b>Note:</b> Two types of data that are shown on the Application Details page are actually stored at the applicant level rather than the application level: personal information and non-resume attachments. This means that if you add or update these types of data in one application, the changes carry over to all of the applicant’s applications.</p>
Recruiting Data	<p>Recruiting data has to do with the relationship between an application and a job opening. Recruiting data includes data related to dispositioning, screening, routing, interviewing, making offers, and preparing applicants for hire.</p> <p>Talent Acquisition Manager users can manage the recruiting process from many different pages. The <a href="#">Manage Application Page</a> provides a central place for managing activity related to a single applicant for a single job opening (or for an application without a job opening).</p>

**Note:** Several recruiting pages include an **Other Actions** menu with submenus for **Application Actions** and **Recruiting Actions**. Applicant Actions refer to actions that affect applicant data, including changing the applicant status or sending correspondence. Recruiting actions can relate to either application data (for example, the Edit Application Details action) or to recruiting data (for example, the Edit Disposition and Prepare Job Offer actions.) On the Manage Applicant page, recruiting actions and some application actions are available from the Applicant Activity Grid. Other applicant actions are available as toolbar buttons.

## Applicant Data

On the Create Applicant page, applicant data is organized into four sections:

<b>Section</b>	<b>Description</b>
<u>Create Applicant Page:</u> <u>Personal Information Tab</u>	<p>This section includes basic identifying information about the applicant, including contact information. You must supply a First Name and Last Name before you can save the applicant record.</p> <p>If you enter an employee ID in the personal information section before you save the record, the system automatically copies certain employee data into the applicant record and also sets the applicant type to <i>Employee</i>.</p>
<u>Create Applicant Page:</u> <u>Applications Tab</u>	<p>The Create Applicant page displays the Applications section only after you save the applicant record. The Applications section lists applications, which contain information about the applicant's qualifications and job preferences. Click an application to access the <u>Application Details Page</u>.</p> <p>The system always creates an initial application on first save, but you can create additional applications from the Applications section. Each application can be linked to one or more job openings, or to no job opening.</p> <hr/> <p><b>Note:</b> The Applications section appears only on the Create Applicant page. After you create the applicant, the other sections listed in this table appear as subsections on the Manage Applicant page: Applicant Data tab. But the Application section does not appear there. Instead, you access application data from Manage Applicant page: Applicant Activity tab, where you manage the recruiting process.</p> <hr/>
<u>Create Applicant Page:</u> <u>References Tab</u>	<p>This section lists the applicant's references and supplies a mechanism for sending a reference request. Applicants are instructed to enter the reference information using Candidate Gateway. Applicants who are not registered Candidate Gateway users are supplied with logon credentials so that they can create an account that will associated with the correct applicant record.</p>
<u>Create Applicant page:</u> <u>Eligibility &amp; Identity Tab</u>	<p>This section lists eligibility and identity information that may be required to comply with local or country regulatory requirements. Eligibility and identity information includes, but is not limited to, data such as national IDs, citizenship, visa and work permits, bank accounts, disabilities, and accommodation requests.</p> <p>This section is visible only to recruiting administrators.</p>

## Application Data

An applicant can have an unlimited number of job applications. Each application can be linked to one or more specific job openings, or to no job opening.

Use the Application Details page in Talent Acquisition Manager to enter or view application data. The Application Details page is a single page that includes all possible application data sections.

When applicants apply using Candidate Gateway, the organization and presentation of the application data fields is different, and a resume template controls which sections are shown during the application process.

The Application Details page includes these types of data:

<b>Section</b>	<b>Description</b>
Resumes	An application can include a resume attachment or resume text that is entered directly in the system (either on this page or in Candidate Gateway). Rich text editing is available for formatting resume text.
Attachments	<p>An application can include cover letters, transcripts, references, or any other attachments that are relevant to the job application.</p> <hr/> <p><b>Note:</b> Non-resume attachments are stored as applicant data, so changes made to one application carry through to all applications.</p> <hr/>
Job Openings	An application can be associated with one or many job openings, or none. The application can also be associated with job families.
Personal information	<p>Personal information includes a disability code, eligibility to work in the U.S., and information about previous employment with your organization. The system does not verify any of this data.</p> <hr/> <p><b>Note:</b> Personal information is stored as applicant data, so changes made to one application carry through to all applications.</p> <hr/>
Preferences	Preferences include information such as the employee's preferred start date and schedule, willingness to relocate or travel, geographic preferences, salary requirements, and shift preferences.
Referral source	The referral source tracks how the applicant learned of the job opening and, in the case of employee referrals, identifies the referring employee.
Work experience	Work experience entries include the employer name, the employment start and stop date, the ending job title, salary information, the employer's contact information, and any freeform comments.
Education level	<p>This is a single entry for the applicant's highest education level. The applicant screening process looks at this data in conjunction with the work experience data to see if the applicant has the amount of experience that is required for applicants with the specified level of education.</p> <p>For details about the applicant's degrees, areas of study, or other education background, use the appropriate profile content type.</p>

<b>Section</b>	<b>Description</b>
Qualifications (profile content types)	<p>The Application Details page includes a grid for every content type in the system's primary person profile. Use these grids to add specific content items to the application.</p> <p>Examples of delivered content types include competencies, degrees, licenses and certifications, and language skills.</p> <p>On the <a href="#">Content Section Configuration – &lt;Content Type&gt; Page</a>, content types can be configured to prevent applicants from adding content items. For example, when an applicant applies using Candidate Gateway, you might want them to rate themselves on the job opening's competencies rather than choosing for themselves which competencies to add to the application.</p> <p>The restriction against adding content items does not apply when a Talent Acquisition Manager user enters application data, but to help the user add the appropriate content items, the Application Details page includes an <b>Import Rateable Profile Items</b> button for bringing in the content items that are associated with the any job openings included in the application.</p>
(USF) Priority placement	Priority placement data can give applicants preferential consideration during the screening process.
(USF) Federal preferences	Use this section to record additional federal preference information

## Recruiting Data, Dispositions, and Draft Applications

Recruiting data tracks the recruiting process for an application for a particular job opening (or for an application without a job opening). It includes detailed data for recruiting processes including screening, routing, interviewing, making offers, and preparing applicants for hire.

The overall status of an application is represented by the disposition. Dispositions are statuses that you configure for the *Recruitment Summary* status area using the [Recruiting Status and Reason Page](#). Dispositions are associated with phases. When you review the applicants for a job opening, the [Manage Job Opening Page: Applicants Tab](#) summarizes the number of applicants in each phase of the recruiting process.

The delivered *Draft* disposition (or whichever disposition you configure as the draft disposition) indicates that an application has not yet been submitted. Draft applications are typically from Candidate Gateway. They can be applications that are still in process, saved for later, or abandoned.

In job opening-related contexts, draft applications are ignored. For example, draft applications:

- Are not visible on the Manage Job Opening page.
- Are not included in the applicant count on the My Job Openings pagelet.
- Are not included in the applicant's job count shown on pages such as the Search Applicant page and the My Applicants pagelet.

Users with access to the Search Applicants page, the Search Applications page, and the Manage Applicant page can see that draft applications exist. They can also perform general applicant tasks that

are not related to a specific application. For example, recruiters can create applicant notes and send correspondence even if the applicant's only application is in draft status.

However, only recruiting administrators can access the application details and the resume, access the Manage Application page, and perform recruiting actions on the application.

---

## Understanding Profile Information in Job Applications

This topic discusses the use of profile information in job applications.

### Profile Architecture

Profiles describe the attributes of jobs or individuals. In PeopleSoft Human Resources, you use the Manage Profiles business process to set up *content types* for a profile. Content types are categories of person or job attributes. For example, Oracle delivers content types for competencies, degrees, licenses & certifications, and many other attributes that are relevant to recruiting.

*Content items* are the specific attributes that the person or job has—that is, the specific competencies, degrees, and so forth.

Optional *Instance Qualifiers* provide logical groupings for content items. For example, competency ratings use the evaluation type as an instance qualifier. This enables the system to differentiate between self-evaluations, manager evaluations, peer evaluations, and so forth. Profile settings determine which types of evaluations are visible to employees and which types can be updated by employees.

The content types that are available for use in PeopleSoft Talent Acquisition Manager are those that belong to the primary person profile type as defined on the [Assign Profile Type Defaults Page](#). Only unsecured content types (those that everyone is allowed to see) are used for recruiting.

### Profile Data for Internal Applicants

Talent Acquisition Manager uses applicant profile information to capture the applicant's qualifications and skills and to match those to job openings, which also include profile information. The applicant's profile information is contained in the job application.

Because your employees already have profiles, the system copies employee profile data into the job applications that an internal applicant creates. The internal applicant can optionally modify the profile data in the application before submitting it.

An employee can have multiple person profiles, but only data from the primary person profile type is copied into applications.

When copying employee profile data into an application:

- The system imports only content items that are visible to employees.
- For content items that have instance qualifiers (such as the rating type for a competency rating), the system imports only those content items that have an instance qualifier that is visible to employees (for example, self-evaluations, but not peer evaluations).
- Only content items that have the employee default instance qualifier (for example, self-evaluation) are available for editing.



If the employee subsequently creates an additional application, the system pulls the employee data into the new application, and also adds any data from the most recently submitted application. This ensures that any new profile content that gets added to a job application gets carried through to the subsequent job applications. Note, however, that profile content that is manually removed from an application continues to appear in each new application as long as it is part of the employee's profile.

Changes to applications never get copied to the employee profile data. And after the system initially populates the profile data in a job application, changes to profile data in one application (or in the employee profile) do not affect any other applications.

---

**Note:** The system also imports two types of non-profile data into employee applications: prior work experience and training.

---

## Instance Qualifiers for Profile Data

Profile architecture uses the concept of an *Instance Qualifier* to organize content types according to specified data. In the case of competencies, the evaluation type (self-evaluation, manager evaluation, and so forth) is the instance qualifier. The instance qualifier setup for competencies not only lists the evaluation types, it indicates which ones employees can view (for example, employees can view manager evaluations, but not peer evaluations), and which one is the default value for employees (for competencies, *Self* is the employee default).

Job applications handle content items with instance qualifiers according to these rules:

- When an internal applicant applies, only content items that are visible to employees are copied from the employee's primary person profile into the job application, and only content items with the employee default instance qualifier are editable.

For example, an employee creates an application, and the system copies the employee's manager evaluations and self evaluations into the application. It does not copy peer evaluations. The employee can see both the manager evaluations and self-evaluations, but can only edit or add self-evaluations.

---

**Note:** If the applicant later submits an additional application, the content items are again copied from the primary person profile, and any additional content items that were added in the previous application are also carried over to the next application. The applicant's ability to add additional content items depends on the settings on the Content Section Configuration page.

---

- When an external applicant applies, instance qualifiers are not shown, but the employee default instance qualifier is assigned to any content items that the employee adds.

For example, an external applicant who adds a competency and rating to the application does not see that the rating is associated with the *Self* evaluation type.

Recruiting users can add content items with other instance qualifiers (for example, a competency rating with an *Executive Committee* evaluation type), but these content items are not visible to the applicant.

---

## Entering Applicant Data

This topic discusses how to enter applicant data.

## Page Used to Enter Applicant Data

<b>Page Name</b>	<b>Definition Name</b>	<b>Usage</b>
<u>Create Applicant Page</u>	HRS_ADD_APPLICANT	Create a new applicant record.
<u>Create Applicant Page: Personal Information Tab</u>	HRS_ADD_APPLICANT	Manage basic identifying information about the applicant, including name and contact information.
<u>Create Applicant Page: Applications Tab</u>	HRS_ADD_APPLICANT	View a list of applications for the applicant. This tab appears after you first save a new applicant record on the Create Applicant page.
<u>Create Applicant Page: References Tab</u>	HRS_ADD_APPLICANT	Manage an applicant's references and send a request for references.
<u>Reference Details Page</u>	HRS_APP_REF_SEC	Add or edit detailed reference information.
<u>Create Applicant page: Eligibility &amp; Identity Tab</u>	HRS_ADD_APPLICANT	Manage eligibility and identity information that may be required to comply with local or country regulatory requirements
<u>National Identification Page</u>	HRS_APP_NID	Enter national ID information for an applicant.
<u>Citizenship Page</u>	HRS_APP_CIT_PSP1	Enter citizenship information for an applicant.
<u>Visa Permit Page</u>	HRS_APP_VSA_PMT1	Enter visa permit information for an applicant.
<u>Bank Account Page</u>	HRS_APP_BANKACCT	Enter bank account information for an applicant.
<u>Disability History Page</u>	HRS_DISUSA_AUD_SEC	View an applicant's disability status history.

### Create Applicant Page

Use the Create Applicant page (HRS\_ADD\_APPLICANT) to create a new applicant record.

---

**Note:** To view data for an existing applicant, use the Manage Applicant page: Applicant Data Tab.

---

Navigation:

## Recruiting > Create Applicant

Initially, the Create Applicant page includes three tabs: Personal Information, References, and Eligibility and Identity. When you save the applicant, the Applications tab appears, and identifying information about the applicant appears in the header area between the toolbar and the tabs.

This example illustrates the Create Applicant page before saving, when there are three tabs.

This example illustrates the Create Applicant page after saving. Now there are four tabs, and the applicant's name and ID are displayed at the top of the page. Also, the toolbar now includes the Manage Applicant button for accessing the Manage Applicant page.

## Processing That Occurs When the Record is First Saved

You must supply the applicant’s name before you can save the record. When the record is first saved, the system assigns an applicant ID, adds header information and an Applications tab to the Create Applicant page, and creates an application for the applicant. The new application is not associated with any job openings.

If you supply an employee ID for the applicant before the first save, the system copies employee profile data into the new application. Otherwise, the new application is blank except for default preference data.

## Toolbar and Header Area

<i>Field or Control</i>	<i>Description</i>
<b>Save</b>	Click to save the applicant data.
<b>Save and Create Another</b>	Click to save the applicant data and immediately open a new blank applicant record.
<b>Recruiting Home</b>	Click to navigate to the <a href="#">Recruiting Home Page</a> .
<b>Manage Applicant</b>	This button appears after you save the record. Click to access the <a href="#">Manage Applicant Page</a> for the newly created applicant. The Manage Applicant page enables you to manage the recruiting process for the applicant, add contact notes, and view and update applicant data.
<b>Name and Applicant ID</b>	These fields display identifying information about the applicant. They appear only after you save the record, which is when the system assigns an applicant ID.

## Tabs

<i>Field or Control</i>	<i>Description</i>
<b>Personal Information</b>	Use the <a href="#">Create Applicant Page: Personal Information Tab</a> to manage name and contact data along with general information such as the applicant type and applicant status.
<b>Applications</b>	Use the <a href="#">Create Applicant Page: Applications Tab</a> to access the application that the system creates when you first save the applicant record. You can also create additional applications from this tab.

<b>Field or Control</b>	<b>Description</b>
<b>References</b>	Use the <a href="#">Create Applicant Page: References Tab</a> to manage and request applicant references.
<b>Eligibility &amp; Identity</b>	Use the <a href="#">Create Applicant page: Eligibility &amp; Identity Tab</a> to manage various information that may be required to comply with local or country regulatory requirements. Because much of this information is sensitive, this tab is visible only to recruiting administrators.

## Create Applicant Page: Personal Information Tab

Use the Create Applicant page: Personal Information tab (HRS\_ADD\_APPLICANT) to enter personal information and contact information for an applicant. You can also manage this data on the Manage Applicant page: Applicant Data tab: Personal Information subsection.

Navigation:

- **Recruiting > Create Applicant**

Access the Personal Information tab.

- **Recruiting > Search Applicants**

Click an applicant name to access the Manage Applicant page, then access the Applicant Data tab: Personal Information subsection.

This example illustrates the Create Applicant page: Personal Information tab

The screenshot displays the 'Create Applicant' page with the 'Personal Information' tab selected. At the top, the applicant's name is 'Nora Dooley' and the ID is '500330'. Below this, there are tabs for 'Personal Information', 'Applications', 'References', and 'Eligibility and Identity'. The 'Applicant' section includes fields for 'Applicant Type' (set to 'External Applicant'), 'Employee ID', 'Preferred Contact' (set to 'Not Specified'), and 'Applicant Status' (set to 'Active'). The 'Name' section has a 'Name Format' dropdown set to 'English', and fields for 'Name Prefix', 'First Name' (Nora), 'Middle Name', 'Last Name' (Dooley), and 'Name Suffix'. The 'Email Addresses' and 'Phone Numbers' sections are empty tables with 'Add' buttons. The 'Address' section includes a 'Country' dropdown set to 'Japan', and fields for 'Postal', 'Prefecture', 'City', and four 'Address' lines. There is also an 'Alternate Character Address' section with 'City' and three 'Address' lines. The page footer contains 'Save', 'Save and Create Another', and 'Top of Page' buttons.

**Applicant**

<b>Field or Control</b>	<b>Description</b>
<b>Applicant Type</b>	<p>Select the type of applicant: <i>External</i>, <i>Employee</i>, or <i>Non-Employee</i>.</p> <p><i>Non-employee</i> indicates that the applicant is a person of interest (rather than an employee) in your Human Resources system.</p> <p>When Candidate Gateway creates an applicant record, it assigns the applicant types based on the navigation or link that the applicant used to access the site.</p>
<b>Preferred Contact</b>	<p>Select the preferred method of contact for the applicant. Values are: <i>Email</i>, <i>Mail</i>, <i>Phone</i>, and <i>Not Specified</i>.</p>

<b>Field or Control</b>	<b>Description</b>
<b>Employee ID</b>	<p>If this is an employee or a person of interest in the system, select the employee ID.</p> <p>If you have not yet saved the applicant record, entering an employee ID sets the applicant type to <i>Employee</i> or <i>Non-Employee</i> based on the information in PeopleSoft Human Resources. When you enter an employee ID, the system imports the employee’s personal information and eligibility &amp; identity data into the applicant record, replacing any existing data. Clearing the field reverses these changes.</p> <p>When you first save a record where an employee ID has been entered, the system brings employee profile data into the new application that is created.</p> <p>After you save the record, changes to the employee ID do not affect any other fields. Additionally, when you view applicant data on the Manage Applicant page, the Employee ID field is hidden when the applicant type is <i>External</i>.</p> <p>See <a href="#">Understanding Profile Information in Job Applications</a>.</p>

## Name

Use this group box to enter the name information for the applicant. Select the name format to determine the type of name fields displayed under this section such as the first name, last name, and preferred first name. To know more on the name fields for the selected name format, see “Name Format Type Page” (Application Fundamentals).

---

**Note:** Talent Acquisition Manager displays only the standard field labels for the names. The customized field labels do not appear in the Create Applicant page.

---

PeopleSoft HCM supports alternate character data entry to enable users to use two character sets for one language. This architecture is described in the topic “Working with Alternate Character Sets” (Application Fundamentals).

The Alternate Character Name field appears if alternate character setting on the “Org Defaults by Permission Lst - Defaults Page” (Application Fundamentals) is enabled for the user’s primary permission list and if the **Format Using** field is *Chinese*, *Hong Kong*, or *Japanese*.

If the recruiting administrator or the recruiter does not provide any value for the Preferred First Name, the First Name value is set as default value for the Preferred First Name.

## Address

Use this group box to enter a single address for the applicant. The fields that appear change depending on the country that you select in the **Country** field. Define address formats on the “Display and Print Page” (Application Fundamentals) in the Country Table (COUNTRY\_TABLE) component.

The Alternate Character fields within the Address group box appears if alternate character functionality is enabled for the user's primary permission list and if the **Country** in the Address group box is *China*, *Hong Kong*, or *Japan*.

Address fields (with lookup) appear as drop-down by default. However, this configuration can be changed from the framework using the Country Format setup. For more information, see "Entry and Validation Page" (Application Fundamentals)

---

**Note:** The system displays warning messages when any address fields are left blank. If it is not a mandatory field, the user can ignore the message and save the data.

---



## Applicant Status

<b>Field or Control</b>	<b>Description</b>
<b>Status Code</b>	<p>Select a status code. This is the overall applicant status, not the applicant's disposition with regards to any particular job opening.</p> <p>You can use the statuses that are provided with the PeopleSoft system, or you can define your own statuses on the <a href="#">Recruiting Status and Reason Page</a>. As delivered, the statuses are:</p> <ul style="list-style-type: none"> <li> <p><i>Active</i>: This is the default status for new applicants.</p> <p>The system also assigns this status when an applicant's resume is in a Success status as part of the resume extraction process.</p> </li> <li> <p><i>Hired</i>: The delivered status change effect rules ensure that the applicant's overall status is set to <i>Hired</i> when the applicant's disposition for a particular job opening changes to <i>Hired</i>.</p> </li> <li> <p><i>Inactive</i>: Under the delivered installation settings, the system uses this status to inactivate duplicate records during the applicant merge process.</p> <p>The system also assigns this status when an applicant's resume is in a Rejected status as part of the batch resume extraction process, which you run from the <a href="#">Load Resume - Prepare Load Parameters Page</a>.</p> <p>Under the delivered status change effects, when you change an applicant's status to <i>Inactive</i>, the applicant's disposition for any job openings that they have applied for is set to <i>Withdrawn</i>. The system excludes inactive applicants from job opening screening.</p> </li> <li> <p><i>Queued</i>: The system assigns this status when an applicant's resume is in a Draft or Unresolved status as part of the resume extraction process.</p> <p>A recruiter could also set this status to indicate that additional information needs to be collected or some other action is needed before the applicant becomes active.</p> </li> </ul>
<b>Status Reason</b>	<p>Select a status reason. Define status reasons for status codes on the <a href="#">Recruiting Status and Reason Page</a>.</p>

<b>Field or Control</b>	<b>Description</b>
<b>Status Date</b>	<p>Enter a status date.</p> <p>The date defaults to the system date. You can use this date for equal employment opportunity (EEO) reporting and other auditing functions.</p>
<b>Registered Online</b>	<p>This field is not visible in add mode (on the Create Applicant page), but it appears when you view personal information on the Manage Applicant page: Applicant Data page.</p> <p>This read-only field displays <i>Yes</i> or <i>No</i> to indicate whether the applicant is a registered user of Candidate Gateway. The value remains <i>Yes</i> even if the Candidate Gateway account is deactivated.</p>
<b>Inactivate Online Account</b>	<p>This field is visible only if the <b>Registered Online</b> field is <i>Yes</i>. Like the <b>Registered Online</b> field, is it not visible in add mode (on the Create Applicant page). Instead, it appears when you view personal information on the Manage Applicant page: Applicant Data page.</p> <p>Select this check box to make the applicant’s Candidate Gateway account inactive. Deselect the checkbox to reactivate the account.</p> <p>You cannot reactivate accounts that deactivated by the applicant merge process. The system recognizes such accounts by their status, which indicates that the account was a duplicate.</p>

### Email Addresses

Use this group box to enter email address information for the applicant. The **Email Address Required** field on the Recruiting Installation – Applicants Page controls whether applicants who register in Candidate Gateway are required to supply an address, but it does not effect whether an email address is required in this grid.

<b>Field or Control</b>	<b>Description</b>
<b>Primary</b>	<p>If any email addresses are listed, one must be marked as primary. The system uses this email address when sending correspondence and notifications. The preferred email address also appears on the My Applicants pagelet on the Recruiting Home page.</p>

<b>Field or Control</b>	<b>Description</b>
<b>Email Type and Email Address</b>	Enter the applicant's email address and identify it as <i>Business</i> , <i>Campus</i> , <i>Dormitory</i> , <i>Home</i> , or <i>Other</i> . You cannot have more than one email address for each email type.

## Phone Numbers

Use this group box to enter phone information for the applicant.

<b>Field or Control</b>	<b>Description</b>
<b>Primary</b>	If any phone numbers are listed, one must be marked as primary. The preferred phone number also appears on the My Applicants pagelet on the Recruiting Home page.
<b>Phone Type</b>	Identify each phone number as <i>Business</i> , <i>Campus</i> , <i>Cellular</i> , <i>Dormitory</i> , <i>Fax</i> , <i>Home</i> , <i>Main</i> , <i>Other</i> , <i>Pager 1</i> , <i>Pager 2</i> , or <i>Telex</i> . You cannot have more than phone number for each phone type.
<b>Telephone, Extension, and Country Code</b>	Enter the phone number.

## Create Applicant Page: Applications Tab

Use the Create Applicant page: Applications tab (HRS\_ADD\_APPLICANT) to review a list of the applicant's job applications.

---

**Note:** This tab appears on the Create Applicant page after you have saved the record. There is no equivalent section header on the Manage Applicant page: Applicant Data tab. Instead, the Manage Applicant page provides access to applications from the Applicant Activity tab.

---

Navigation:

**Recruiting > Create Applicant**

Access the Applications tab.

This example illustrates the Create Applicant page: Applications tab.

**Note:** You can create multiple applications for an applicant.

## Applications

This grid lists the applicant’s applications. There is always at least one application because the system creates an application when you first save the applicant record.

<b>Field or Control</b>	<b>Description</b>
<b>Resume Title</b>	Displays the title of the resume that is associated with the application. If the application does not include a resume, or if the resume has no title, this field displays <i>No Resume Title Entered</i> .
<b>Last Updated and Last Updated By</b>	These fields display information about the last update to the application data.
 <b>Edit Application Details</b>	<p>Click this link to access the Application Details page, where you can view and modify the application data.</p> <p>Remember that the system creates a blank application when you first save the applicant record. The best practice is to use this existing application for the applicant’s first job application. Until you enter a job opening ID for the application, the application is considered to be an application without a job opening.</p> <p>If you exit the Create Applicant component, use the Edit Application Details action to access and update the existing application.</p> <p>See <a href="#">Understanding Actions for Managing Applicants</a>.</p>
<b>Add Application</b>	Click this link to access the Application Details page for a new application.

## Create Applicant Page: References Tab

Use the Create Applicant page: References tab (HRS\_ADD\_APPLICANT) to review references for an applicant, and add and edit references. You can also manage this data on the Manage Applicant page: Applicant Data tab: References subsection.

Navigation:

- **Recruiting > Create Applicant**

Access the References tab.

- **Recruiting > Search Applicants**

Click an applicant name to access the Manage Applicant page, then access the Applicant Data tab: References subsection.

This example illustrates the Create Applicant page: References tab.

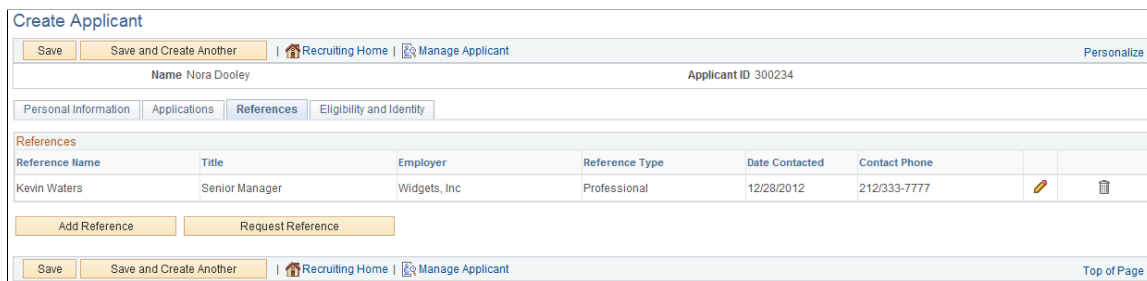

## References

Use this group box to view summary information about each reference. This data comes from the [Reference Details Page](#).

<i>Field or Control</i>	<i>Description</i>
<b>Edit References</b>	Click to access the Reference Details page. Use the Reference Details page to view and edit detailed information about the reference.

## Additional Buttons

<i>Field or Control</i>	<i>Description</i>
<b>Add Reference</b>	Click to access the Reference Details page, where you can enter new reference information for the applicant.

<b>Field or Control</b>	<b>Description</b>
<b>Request Reference</b>	<p>Click to send a request for references email notification (HRS_UPDATE_REFERENCES) to the applicant. The applicant must have a primary email address so that the system can send this request.</p> <p>The notification instructs the applicant to use Candidate Gateway to enter reference information. If the applicant is not yet a registered user of Candidate Gateway, the system generates a Candidate Gateway user ID and password for the applicant and includes them in the email notification. By using these system-generated logon credentials, the applicant ensures that the Candidate Gateway account is properly associated with the existing applicant record. The auto-generated password is valid for a single use, and the applicant is prompted to change the password immediately after signing in.</p> <p>In Candidate Gateway, the Notifications page displays the request for references. The applicant must click the notification link to access the page where reference information is entered.</p>

## Reference Details Page

Use the Reference Details page (HRS\_APP\_REF\_SEC) to add or edit reference information.

Navigation:

On the Create Applicant page or the Manage Applicant page, first access the References section. Next, click the **Add Reference** button or, to modify an existing record, click the **Edit** icon.

This example illustrates the Reference Details page.

**Reference Details**

Reference Number 1

\*Date Contacted   \*Reference Type

\*Reference Name

Title

Employer

Email Address

Country

Address

Country Code  Contact Phone

Comment

Enter information about the person who provided the reference, then use the **Comments** field to record your notes.

## Create Applicant page: Eligibility & Identity Tab

Use the Create Applicant page: Eligibility & Identity tab (HRS\_ADD\_APPLICANT) to enter eligibility and identity information for an applicant. You can also manage this data on the Manage Applicant page: Applicant Data tab: Eligibility & Identity subsection.

---

**Important!** This tab contains sensitive information and is therefore visible only to recruiting administrators.

---

Navigation:

- **Recruiting > Create Applicant**

Access the Eligibility & Identity tab.

- **Recruiting > Search Applicants**

Click an applicant name to access the Manage Applicant page, then access the Applicant Data tab: Eligibility & Identity subsection.

This is the first of four examples that illustrate the Create Applicant page: Eligibility & Identity tab.

Create Applicant
Recruiting Home | Manage Applicant
Personalize

Name Nora Dooley
Applicant ID 300228

Personal Information
Applications
References
Eligibility and Identity

Personal Information

Date of Birth <input style="width: 80%;" type="text"/>	*Marital Status <input style="width: 90%;" type="text" value="Unknown"/>
*Gender <input style="width: 80%;" type="text" value="Unknown"/>	Ethnic Group <input style="width: 90%;" type="text" value="Not Specified"/>

- ▶ Canada
- ▶ Switzerland
- ▶ Germany
- ▶ Spain
- ▶ France
- ▶ United Kingdom
- ▶ Italy
- ▶ Japan
- ▶ USA
- ▶ Australia
- ▶ Malaysia
- ▶ New Zealand
- ▶ Singapore

This is the second of four examples that illustrate the Create Applicant page: Eligibility & Identity tab.

National Identification

No National Identification has been added for this applicant.

Add National Identification

Citizenship

No Citizenship has been added for this applicant.

Add Citizenship

Visa Permit

No Visa Permit has been added for this applicant.

Add Visa Permit

Bank Account

No Bank Account has been added for this applicant.

Add Bank Account





This is the third of four examples that illustrate the Create Applicant page: Eligibility & Identity tab.

**Applicant Disability**

Disabled

 Switzerland

 Germany

 Spain

 France

 Italy

 Japan

 Netherlands

 United Kingdom

 USA

**Section 503 Disability**

Disability Status  [View History](#)

Disclosure Date  

**Veteran**

Disabled Veteran

 New Zealand

 Brazil

This is the fourth of four examples that illustrate the Create Applicant page: Eligibility & Identity tab.

The screenshot displays two stacked form panels. The top panel, titled 'Accommodation Request', contains an 'Applicant Information' section with fields for '\*Accommodation ID' (value: 1), '\*Date of Request', a 'Comment' text area, '\*Responsible ID', '\*Request Status' (dropdown: Pending), and '\*Status Date'. Below this is a 'Diagnosis' section with fields for '\*Regulatory Region' and 'Diagnosis Code'. The bottom panel, titled 'Accommodation Option', contains an 'Applicant Information' section with 'Accommodation ID' (1) and 'Date of Request'. The 'Option Details' section includes '\*Option ID' (1), '\*Currency Code' (USD), an 'Employer Suggested Option' checkbox, '\*Type', 'Cost' (0.00), 'Description' text area, '\*Status' (dropdown: Consider), and '\*Status Date'. At the bottom of the page are buttons for 'Save' and 'Save and Create Another', along with navigation links for 'Recruiting Home' and 'Manage Applicant'.

## Personal Information

Use this group box to enter date of birth, gender, and marital status and, in U.S. Federal implementations, to enter an ethnic group.

Date of birth and gender can be used to screen applicants. Date of birth is used to calculate the applicant's age and is compared to the **Maximum** and **Minimum Age** fields on the Job Opening page.

## Country-Specific Information

Enter additional country-specific information for applicants. Entering citizenship information for an applicant is similar to entering citizenship information for an employee.

See “Add a Person or Modify a Person - Regional Page” (PeopleSoft Human Resources Administer Workforce).

## (USA) Ethnicity and Veteran Information for the United States

If applicants supply ethnicity and veteran information through Candidate Gateway, that information appears in the USA section of the Eligibility & Identity page.

**Note:** The U.S. Department of Labor’s Office of Federal Contract Compliance Programs (OFCCP) issues regulations related to collecting Veteran information from applicants. In Candidate Gateway, settings on the “Site Setup Page” (PeopleSoft Candidate Gateway) control whether applicants are invited to self-identify as veterans while applying for jobs.

This example illustrates the fields in the USA section of the Eligibility & Identity tab.

**Note:** The Ethnic Group scroll area does not appear here in a U.S. Federal system. Instead, Ethnic Group information appears in the Personal Information group box.

<b>Field or Control</b>	<b>Description</b>
<b>Ethnic Group</b>	Ethnic group information appears in a scroll area regardless of whether you use the two-question format for collecting the information. If you use the two-question format and an applicant answers <i>Yes</i> to the question <i>Are you Hispanic or Latino</i> , then the system inserts a row for the ethnic group <i>Hispanic/Latino</i> in addition to one or more rows for the applicant’s answer to the question <i>What is your race?</i>
<b>Effective Date</b>	For veteran data that is collected in Candidate Gateway, the effective date is the date that the application was submitted.
<b>Military Status</b>	For veteran data that is collected in Candidate Gateway, this field displays the military status that corresponds to information that the applicant provided on the Veteran page.  For information about how the self-identification options map to Military Status values, refer to the documentation for the Veteran page in the topics “Applying for Jobs” (PeopleSoft Candidate Gateway) and “Using Fluid Candidate Gateway to Apply for Jobs” (PeopleSoft Candidate Gateway).

<i>Field or Control</i>	<i>Description</i>
<b>Military Discharge Date</b>	For veteran data that is collected in Candidate Gateway, this field displays the date, if any, that the applicant entered in the <b>Military Discharge Date</b> field on the Veteran page.

### National Identification

<i>Field or Control</i>	<i>Description</i>
<b>Add National Identification and Edit National ID</b>	Click to access the National ID page, where you can enter new or edit existing national ID information for the applicant. Entering national ID information for an applicant is similar to entering national ID information for an employee.  See “Biographical Details Page” (PeopleSoft Human Resources Administer Workforce).

### Citizenship

<i>Field or Control</i>	<i>Description</i>
<b>Add Citizenship and Edit Citizenship Details</b>	Click to access the Citizenship page, where you can enter new or edit existing citizenship information for the applicant. Entering citizenship information for an applicant is similar to entering citizenship information for an employee.  See “Citizenship/Passport Page” (PeopleSoft Human Resources Administer Workforce).

### Visa Permit

<i>Field or Control</i>	<i>Description</i>
<b>Add Visa Permit and Edit Visa Permit Details</b>	Click to access the Visa Permit Details page, where you can enter new or edit existing visa permit details. Entering visa information for an applicant is similar to entering visa information for an employee.  See “Visa/Permit Data Page” (PeopleSoft Human Resources Administer Workforce).

## Bank Accounts

<b>Field or Control</b>	<b>Description</b>
<b>Add Bank Account</b> and <b>Edit Bank Account</b>	<p>Click to access the Bank Account page, where you can enter new or edit existing bank account information for the applicant. Entering bank account information for an applicant is similar to entering bank account information for an employee.</p> <p>See “Maintain Bank Accounts Page” (PeopleSoft Human Resources Administer Workforce).</p>

## Applicant Disability

Use this group box to mark an applicant as having a disability and to enter country-specific disability information. Entering disability information for an applicant is similar to entering disability information for an employee.

See “Disability Page” (PeopleSoft Human Resources Administer Workforce).

---

**Note:** The U.S. Department of Labor’s Office of Federal Contract Compliance Programs (OFCCP) issues regulations related to collecting disability information from applicants. In Candidate Gateway, settings on the “Site Setup Page” (PeopleSoft Candidate Gateway) control whether applicants are invited to self-identify their disability status while applying for jobs.

---

<b>Field or Control</b>	<b>Description</b>
<b>Disability</b> (not country-specific)	<p>Changes to the USA disability status (in the Section 503 Disability Status group box in the USA section) flow through to this non-country-specific check box:</p> <ul style="list-style-type: none"> <li>• A Section 503 Disability Status of <i>Disabled</i> selects this check box.</li> <li>• A Section 503 Disability Status of <i>Not Disabled</i> deselects this check box.</li> <li>• A Section 503 Disability Status of <i>Not Indicated</i> has no effect on this check box.</li> </ul> <p>Changes to the non-country-specific check box do <i>not</i> change the value of the Section 505 disability status.</p> <p>This check box does is not affected by (and does not affect) the Disabled Veteran check box.</p>

<b>Field or Control</b>	<b>Description</b>
<b>(USA) Disability Status</b>	<p>For disability data that is collected in Candidate Gateway, this field displays a status that corresponds to the applicant’s self-identified disability information.</p> <ul style="list-style-type: none"> <li>• <i>Disabled</i> corresponds to the self-identified YES, I HAVE A DISABILITY (or previously had a disability) option.</li> <li>• <i>Not Disabled</i> corresponds to the self-identified NO, I DON’T HAVE A DISABILITY option.</li> <li>• <i>Not Indicated</i> corresponds to the self-identified I DON’T WISH TO ANSWER option. This value is also used when an applicant is invited to provide disability information but does not provide any.</li> </ul>
<b>View History</b>	<p>Click to access the Disability History page, where you can view the applicant’s disability status over time.</p>
<b>(USA) Disclosure Date</b>	<p>For data that is collected in Candidate Gateway, the disclosure date is the date that the application was submitted.</p>
<b>(USA) Disabled Veteran</b>	<p>If the applicant selected the Disabled Veteran check box on the Veteran page in Candidate Gateway, this check box is selected.</p>

### Accommodation Request

Use this group box to enter accommodation requests for an applicant with a disability. Entering accommodation requests for an applicant is similar to entering accommodation requests for an employee.

See “Accommodation Request Page” (PeopleSoft Human Resources Meet Regulatory Requirements).

### Accommodation Options

Use this group box to enter accommodation options for an applicant with a disability. Entering accommodation options for an applicant is similar to entering accommodation options for an employee.

See “Accommodation Option Page” (PeopleSoft Human Resources Meet Regulatory Requirements).

## National Identification Page

Use the National ID page (HRS\_APP\_NID) to enter national ID information for an applicant.

Navigation:

On the Create Applicant page or the Manage Applicant page, first access the Eligibility & Identity section. Next, click the **Add National Identification** button or, to modify an existing record, click the **Edit** icon.

This example illustrates the National Identification page.

The screenshot shows a window titled "National Identification". It contains the following fields and controls:

- \*Country: A text input field with a magnifying glass icon.
- \*National ID Type: A text input field with a magnifying glass icon.
- National ID: A long text input field.
- National ID Expiry Date: A date input field with a calendar icon.
- Primary ID: A checkbox that is checked.
- OK and Cancel: Two buttons at the bottom left.

## Citizenship Page

Use the Citizenship page (HRS\_APP\_CIT\_PSP1) to enter citizenship information for an applicant.

Navigation:

On the Create Applicant page or the Manage Applicant page, first access the Eligibility & Identity section. Next, click the **Add Citizenship** button or, to modify an existing record, click the **Edit** icon.

This example illustrates the Citizenship page.

The screenshot shows a window titled "Citizenship". It contains the following fields and controls:

- \*Country: A text input field with a magnifying glass icon.
- Citizenship Status: A text input field with a magnifying glass icon.
- Passport Details: A section with a "Find" button and "First 1 of 1 Last" navigation. It includes:
  - \*Passport Number: A text input field with "+" and "-" buttons.
  - Issue Date: A date input field with a calendar icon.
  - Expiration Date: A date input field with a calendar icon.
  - Country: A text input field with a magnifying glass icon.
  - State: A text input field with a magnifying glass icon.
  - City: A text input field.
  - Comment: A large text area with a magnifying glass icon.
- Singapore: A dropdown menu with a flag icon.
- Worker Type: A dropdown menu.
- Permanent Status Date: A date input field with a calendar icon.
- OK and Cancel: Two buttons at the bottom left.

## Visa Permit Page

Use the Visa Permit page (HRS\_APP\_VSA\_PMT1) to enter visa permit information for an applicant.

Navigation:

On the Create Applicant page or the Manage Applicant page, first access the Eligibility & Identity section. Next, click the **Add Visa Permit** button or, to modify an existing record, click the **Edit** icon.

This example illustrates the Visa Permit page.

The screenshot shows a 'Visa Permit' form with the following fields and values:

- \*Country: [Text Field]
- \*Visa/Permit Type: [Text Field]
- Visa/Permit Class: [Text Field]
- \*Status: Applied For (Dropdown)
- Number: [Text Field]
- \*Status Date: 12/20/2013 (Calendar)
- Duration: [Text Field]
- Months: (Dropdown)
- Start Date: [Text Field]
- Expiration Date: [Text Field]
- Issue Date: [Text Field]
- Issue Place: [Text Field]
- Issuing Authority: [Text Field]

Supporting Documents Table:

Supporting Document ID	Description	Request Date	Date Received
[Text Field]	[Text Field]	[Text Field]	[Text Field]

## Bank Account Page

Use the Bank Account page (HRS\_APP\_BANKACCT) to enter bank account information for an applicant.

Navigation:

On the Create Applicant page or the Manage Applicant page, first access the Eligibility & Identity section. Next, click the **Add Bank Account** button or, to modify an existing record, click the **Edit** icon.



This example illustrates the Bank Account page.

## Disability History Page

Use the Disability History page (HRS\_DISUSA\_AUD\_SEC) to view an applicant’s disability status history.

Navigation:

On the Create Applicant page or the Manage Applicant page, first access the Eligibility & Identity section. Next, click the **View History** link in the USA section of the Applicant Disability section.

This example illustrates the Disability History page.

Disability History					
Find   View All					
First 1-3 of 3 Last					
Audit Date/Time	Audit User ID	Disability Status	Applicant Signature	Disclosure Date	Presented Disability Form
03/10/2015 9:21:14.000000PM	PS	Disabled		03/10/2015	Y
03/03/2015 9:20:00.000000PM	PS	Not Indicated	Karla Benefer	03/03/2015	Y
03/03/2015 9:19:02.000000PM	PS				Y

Candidate Gateway adds rows to the disability history when an applicant submits an application that included the Disability page (regardless of whether the applicant entered any disability information).

Talent Acquisition Manager adds rows to the disability history when a user saves a change to the Disability Status field in the applicant’s Eligibility & Identity information.

<b>Field or Control</b>	<b>Description</b>
<b>Audit Date/Time</b>	Displays the date and time that the data was saved.
<b>Audit User ID</b>	Displays the user ID of the person who saved the data. For external applicants, the user ID is the guest user ID that provides access to the Candidate Gateway site.

<b>Field or Control</b>	<b>Description</b>
<b>Disability Status</b>	Displays the disability status that was saved on the specified date and time. This field is blank if an applicant who saw the Disability page in Candidate Gateway did not select any value.
<b>Applicant Signature</b>	<p>If an applicant provided disability information in Candidate Gateway, the applicant’s name appears here.</p> <p>This field is blank if the applicant saw the Disability page but did not provide any information. The field is also blank if the disability status was entered in Talent Acquisition Manager.</p>
<b>Disclosure Date</b>	<p>If an applicant provided the information in a Candidate Gateway job application, the disclosure date is the date that the application was submitted.</p> <p>If a Talent Acquisition Manager user entered the information, the user manually specifies the disclosure date.</p>
<b>Presented Disability Form</b>	<p>Displays <i>N</i> (No) if the information was entered in Talent Acquisition Manager and the applicant has not previously been presented with the Disability page in Candidate Gateway.</p> <p>Displays <i>Y</i> (Yes) starting with the first row that represents a Candidate Gateway job application that included the Disability page. After the applicant has seen the disability form once, all subsequent history rows have a <i>Y</i> in this field.</p>

## Entering Application Details

This topic discusses how to enter application details.

### Pages Used to Enter Application Details

<b>Page Name</b>	<b>Definition Name</b>	<b>Usage</b>
<u>Application Details Page</u>	HRS_APP_PROFILE	Add or edit job application details.
<u>View Questionnaire Page</u>	HRS_APP_QSTN_RSLT	Review an applicant's answers to a completed questionnaire.
<u>Work Experience Page</u>	HRS_APP_WRK_SEC	Add or edit work experience details.
<u>&lt;Content Type&gt; Page for Applicants</u>	HRS_APP_DETAIL	Add or edit applicant profile information such as competencies, degrees, licenses & certificates, language skills, and so forth.

<b>Page Name</b>	<b>Definition Name</b>	<b>Usage</b>
<u>(USF) Priority Placement Page</u>	HRS_CE_ADM_PP	(USF) Add or edit priority placement information for U.S. federal implementations.

## Application Details Page

Use the Application Details page (HRS\_APP\_PROFILE) to enter or review the applicant's complete job application details. The page title is either Add Application Details or Edit Application Details, depending on context.

The Application Details page corresponds to an application form. It is the only page where you can enter or edit application data.

To take actions related to an application, use the Manage Application Page instead. The Manage Applications page includes a read-only view of the data from the Application Details page so that you can review the information as you evaluate the application and take action.

Navigation:

- Click the **Add Application** button on the Create Applicant page: Applications tab.
- Click the **Add Application** toolbar button on the Manage Applicant page.
- Select **Other Actions > Recruiting Actions > Edit Application Details** on various pages, including Search Applications, Search Applicants (keyword search and advanced search), Manage Applicant, Manage Application, and Manage Job Opening.

This is the first of four examples that illustrate the Application Details page.

The screenshot displays the 'Edit Application Details' interface for an applicant named Nora Dooley. The page is divided into several sections:

- Applicant Information:** Name: Nora Dooley, Applicant ID: 500290, Applicant Type: External Applicant, Status: 010 Active. Preferred Contact: Not Specified, Phone: 212/510-5556, Email: nora.dooley@email.com, Address: 2514 Holly Lane Anytown, NY 11111.
- Job Openings:** A table with columns for Job Opening ID and Posting Title. One entry is visible: Job Opening ID 504032, Posting Title Labor Relations Specialist.
- Job Families:** A table with columns for Job Family and Description. No entries are currently listed.
- Personal Information:** Eligible to Work in U.S.: No, Are you a former employee: No, Previous Termination Date: (empty).
- Resume Section:** Includes fields for Resume Title (Nora Dooley Resume) and Language Code (English). A 'Resume Attachment' section shows an attached file 'Nora\_Dooley\_Resume.pdf'. Below this is a rich text editor for 'No Resume Text' with a standard toolbar.

This is the second of four examples that illustrate the Application Details page.

**Preferences**

Desired Start Date:

Regular/Temporary:

Full/Part-Time:

Willing to Relocate:

Willing to Travel:

Travel Percentage:

**Geographic Preference**

First Choice:

Second Choice:

Comments:

Desired Work Days:  Monday  Tuesday  Wednesday  Thursday  Friday  Saturday  Sunday

Minimum Pay:

Currency Code:

Pay Frequency:

Desired Shift:  Not Applicable  Day  Evening  Night  Compressed  Rotating  Any

Desired Hours Per Week:

Letter:

Date Printed:

**Attachments**

Attachment	Attachment Title	Attachment Type	Apply to All	Last Updated	Uploaded By	
JKB_References.pdf	JKB_References	References	<input type="checkbox"/>	09/14/2015 4:35PM	Betty Locherty	<input type="button" value="Delete"/>
JKB_Writing_Sample.pdf	Jessica Butler W		<input checked="" type="checkbox"/>	09/14/2015 3:33PM	Betty Locherty	<input type="button" value="Delete"/>
JKB_Transcript.pdf	J Butler Transcri	Transcripts	<input checked="" type="checkbox"/>	09/14/2015 3:31PM	Jessica Butler	<input type="button" value="Delete"/>
JKB_Cover_Letter.pdf	J Butler Consulti	Cover Letters	<input type="checkbox"/>	09/14/2015 3:25PM	Jessica Butler	<input type="button" value="Delete"/>

**Work Experience**

No work experience has been added for this applicant.

**Education Level**

Highest Education Level:

**Training**

No Training has been added for this applicant.

**Competencies**

Competencies	Competency	Effective Date	Evaluation Type	Proficiency	
Abstract thinking	0100	09/14/2015	Self	S-Expert	<input type="button" value="Delete"/>

This is the third of four examples that illustrate the Application Details page.

**Referral Source**

How did you learn of the job?

Additional Information:

Specific Referral Source:

**US Federal**

**Priority Placement**

No Placement has been added for this applicant.

**School Education**

No School Education have been added to this applicant's profile.

**Educ and Govt Special Projects**

No Educ and Govt Special Projects have been added to this applicant's profile.

**Elements**

No Elements have been added to this applicant's profile.

This is the fourth of four example that illustrate the Application Details page.

<p><b>Federal Preferences</b></p> <p>Federal civilian employee? <input type="checkbox"/> Previous Federal Employee  <input type="checkbox"/> Previous Agency Employee  <input type="checkbox"/> Current Federal Employee  <input type="checkbox"/> Current Agency Employee</p> <p>Highest Pay Plan <input type="text"/></p> <p>Highest Grade <input type="text"/></p> <p>Minimum Acceptable Pay Plan <input type="text"/></p> <p>Minimum Acceptable Grade <input type="text"/></p> <p>Highest Career Tenure <input type="text"/></p> <p>Veterans Preference <input type="text" value="None"/></p> <p>Reserve Category <input type="text"/></p> <p>Uniformed Service <input type="text"/></p> <p>Military Grade <input type="text"/></p> <p>Military Separation Status <input type="text"/></p> <p>Military Service Start Date <input type="text" value="12/29/2012"/></p> <p>End Date <input type="text"/></p> <p>Creditable Military Service <input type="text"/></p> <p><input type="checkbox"/> Military Service Verified  <input type="checkbox"/> Veterans Preference RIF</p> <p>Effective Date <input type="text" value="12/29/2012"/></p> <p>Military Status <input type="text" value="Not indicated"/></p>	<p><b>Geographic Preferences</b></p> <p>No Geographic Preferences have been added to this applicant's profile.</p> <p><a href="#">Add Geographic Preferences</a></p> <p><b>Honors and Awards</b></p> <p>No Honors and Awards have been added to this applicant's profile.</p> <p><a href="#">Add Honors and Awards</a></p> <p><b>International Preferences</b></p> <p>No International Preferences have been added to this applicant's profile.</p> <p><a href="#">Add International Preferences</a></p> <p><b>Licenses and Certifications</b></p> <p>No Licenses and Certifications have been added to this applicant's profile.</p> <p><a href="#">Add Licenses and Certifications</a></p> <p><b>Language Skills</b> <span style="float: right;">Find   <input type="text"/>   <input type="text"/> First 1-2 of 2 Last</span></p> <table border="1"> <thead> <tr> <th>Language Skills</th> <th>Language</th> <th></th> </tr> </thead> <tbody> <tr> <td>English</td> <td>EN</td> <td><input type="text"/></td> </tr> <tr> <td>Spanish</td> <td>SP</td> <td><input type="text"/></td> </tr> </tbody> </table> <p><a href="#">Add Language Skills</a></p> <p><b>Location</b></p> <p>No Location have been added to this applicant's profile.</p> <p><a href="#">Add Location</a></p> <p><b>Location Preferences</b></p> <p>No Location Preferences have been added to this applicant's profile.</p> <p><a href="#">Add Location Preferences</a></p> <p><b>Memberships</b></p> <p>No Memberships have been added to this applicant's profile.</p> <p><a href="#">Add Memberships</a></p> <p><b>Responsibilities</b></p> <p>No Responsibilities have been added to this applicant's profile.</p> <p><a href="#">Add Responsibilities</a></p>	Language Skills	Language		English	EN	<input type="text"/>	Spanish	SP	<input type="text"/>
Language Skills	Language									
English	EN	<input type="text"/>								
Spanish	SP	<input type="text"/>								

**Toolbar**

<b>Field or Control</b>	<b>Description</b>
<b>Save</b>	Click to save the application.
<b>Return</b>	Click to return the page from which you accessed the Application Details page. If you have unsaved changes, the system displays a message and you can choose whether to cancel the changes or go back to the Application Details page and save them.
<b>Recruiting Home</b>	Click to access the <a href="#">Recruiting Home Page</a> . If you have unsaved changes, the system displays a message and you can choose whether to cancel the changes or go back to the Application Details page and save them.
<b>Previous and Next</b>	These buttons appear if you accessed the Application Details page by selecting multiple applications on a page and then using the Group Actions menu to invoke the <b>Edit Application Details</b> action. Use the buttons to navigate between applications.

## Header

<b>Field or Control</b>	<b>Description</b>
<b>Name and Applicant ID</b>	These fields display identifying information about the applicant.
<b>Applicant Type</b>	Displays whether the applicant is an <i>External Applicant</i> , <i>Employee</i> , or a <i>Non-Employee</i> (a person of interest).
<b>Status</b>	Displays the overall applicant status. This is not the disposition with regards to any particular job opening, it is a more general status such as <i>Active</i> or <i>Inactive</i> .
<b>Preferred Contact</b>	Displays the applicant's preferred contact method.
<b>Phone, Email, and Address</b>	These fields display the applicant's contact information.

## Job Openings

Use this grid to view the job openings that are linked to this application and to link additional job openings to the application.

<b>Field or Control</b>	<b>Description</b>
<b>Job Opening ID</b> and Posting Title	<p>These fields identify the job opening that is linked to the application.</p> <p>When you add a job opening to the grid, the linkage is assigned the default disposition according to your configurable status settings. As delivered, the default disposition is <i>Applied</i>.</p> <p>When you add a job to this grid, Candidate Gateway lists the jobs separately in the applicant’s list of applications (rather than showing one multi-job application).</p> <p>If you add a job opening that includes a questionnaire, and if the job is posted to Candidate Gateway, the system invites the applicant to submit an additional application. Submitting an additional application gives the applicant a way to answer the questionnaire.</p> <p>To invite the applicant to submit a new application, the system sends an email with directions for signing on to Candidate Gateway and applying for the job. The system also creates a contact note with a record of the outgoing email and creates a Candidate Gateway notification (one that the applicant sees after signing in to Candidate Gateway).</p> <p>For more information about linking applicants to job openings with questionnaires, see <a href="#">Understanding Questionnaires in Linked Jobs</a>.</p> <hr/> <p><b>Note:</b> Although you can clear the data in the Job Opening ID field, you cannot delete rows from this grid.</p> <hr/>
<b>View Questionnaire</b>	<p>Click this link to view the completed online questionnaire for this job opening. The online questionnaire consists of any screening questions that are associated with the job opening.</p> <p>The link appears only for job openings where the applicant has answered the questionnaire. Applicants complete questionnaires in Candidate Gateway, either when initially applying or after receiving a request to submit an application for a job opening with a questionnaire.</p>
<b>Add Job Opening</b>	<p>Click this link to add a blank row to the Job Openings grid so that you can select another job opening to associate with this application.</p>

<b>Field or Control</b>	<b>Description</b>
<p><b>Import Ratable Profile Items</b></p>	<p>Click this button to add certain content items from the job openings that are associated with the application. The imported items are from content types that are configured such that applicants supply ratings for predefined content items rather than choosing which content items to add.</p> <p>(Specifically, these are the content types where the <b>Applicant May Add Items</b> check box is not selected on the <u><a href="#">Content Section Configuration – &lt;Content Type&gt; Page</a></u>.</p> <p>For example, the delivered content type configuration for competencies prevents applicants from adding competencies to their applications. The assumption is that you want to rate applicants on specific job-related competencies that you have defined in the job opening. To facilitate data entry, and to ensure that you rate applicants on the correct set of competencies, you click the <b>Import Ratable Profile Items</b> button. If there are any competencies that are associated with the job openings listed in the application, the system copies those competencies to the application so that you can enter applicant-specific ratings.</p>

### Job Families

Use this grid to identify one or more job families that the applicant is interested in. This information can be used as a means of searching for applicants that are interested in jobs within a specific job family.

### Personal Information

<b>Field or Control</b>	<b>Description</b>
<p><b>(USF) Disability Code</b></p>	<p>If the applicant is disabled, select the code that identifies the type of disability. Otherwise, select <i>No Handicap</i>. Define disability codes on the Handicap Table page.</p>



<b>Field or Control</b>	<b>Description</b>
<b>Eligible to Work in U.S.</b>	<p>Select <i>Yes</i> or <i>No</i> to indicate whether or not the applicant is eligible to work in the United States.</p> <p>This field is the same as the identically-named field that appears in the USA group box of the applicant data Eligibility &amp; Identity section. Changes made to this field carry over to all of the applicant's applications and to the Eligibility &amp; Identity section of the applicant data.</p> <p>In Candidate Gateway, job applications include this field only if the resume template includes the Federal Preferences section.</p>
<b>Are you a former employee</b>	<p>Select <i>Yes</i> or <i>No</i> to indicate whether the applicant is a former employee. This setting is independent of the applicant type and employee ID shown in the Personal Information section of the applicant data.</p> <p>On the Search Applicants page, a Former Employee icon appears in the search results grid when this field has a <i>Yes</i> value.</p> <p>The value in this field also affects the available hire types on the <a href="#">Prepare For Hire Page</a>. If the value is <i>Yes</i>, the <i>Rehire</i> option replaces the <i>Hire</i> option.</p>
<b>Previous Termination Date</b>	<p>If the applicant is a former employee, enter the applicant's last day worked, if known.</p>

## Preferences

<b>Field or Control</b>	<b>Description</b>
<b>Desired Start Date</b>	<p>Enter the earliest date that the applicant is available to start.</p> <p>This field can be used to screen applicants. It is compared to the <b>Start Date</b> field on the job opening.</p>
<b>Regular/Temporary</b>	<p>Select <i>Regular</i> if the applicant is seeking a permanent job, <i>Temporary</i> if the applicant wants a temporary contract, or <i>Either</i> if the applicant is willing to consider both.</p> <p>This field can be used to screen applicants. It is compared to the <b>Regular/Temporary</b> field on the job opening.</p>

<b>Field or Control</b>	<b>Description</b>
<b>Full/Part-Time</b>	<p>Select either <i>Full-Time</i> or <i>Part-Time</i> if the applicant is seeking a particular type of job, or <i>Either</i> if the applicant is willing to consider both full-time and part-time jobs.</p> <p>This field can be used to screen applicants. It is compared to the <b>Full/Part-Time</b> field on the job opening.</p>
<b>Willing to Relocate</b>	<p>Select <i>Yes</i> or <i>No</i> to indicate whether the applicant is willing to move to a new location.</p>
<b>Willing to Travel</b>	<p>Select <i>Yes</i> or <i>No</i> to indicate whether the applicant is willing to travel for work, .</p>
<b>Travel Percentage</b>	<p>Select a value that indicates the maximum amount of time that the applicant is willing to travel for work: <i>Never or Rarely</i>, <i>Up to 25% of the time</i>, <i>Up to 50% of the time</i>, <i>Up to 75% of the time</i>, or <i>Up to 100% of the time</i>,</p> <p>This field can be used to screen applicants. It is compared to the <b>Travel Percentage</b> field on the job opening.</p>

### Geographic Preference

<b>Field or Control</b>	<b>Description</b>
<b>First Choice and Second Choice</b>	<p>Enter the applicant's first and second location choices. The recruiting locations that appear in these prompts are those that are associated with the set ID for the business unit to which the user belongs. Recruiting locations are defined on the Recruiting Location page.</p> <p>This field can be used to screen applicants. It is compared to the values in the recruiting locations grid on the job opening.</p> <p>See <a href="#">Recruiting Locations Page</a>.</p>
<b>Comments</b>	<p>Enter comments about an applicant's geographic preference. The screening process does not evaluate these comments.</p>

## Additional Preference Fields

<i>Field or Control</i>	<i>Description</i>
<b>Desired Work Days</b>	Select the check boxes next to the days that the applicant is willing to work.
<b>Minimum Pay, Currency Code, and Pay Frequency</b>	<p>Use these fields to specify the applicant's minimum salary requirements.</p> <p>For example, if the minimum acceptable pay is 70,000 CAD per year, enter <i>70,000</i> in the <b>Minimum Pay</b> field, select <i>CAD</i> in the <b>Currency Code</b> field, and select <i>Year</i> in the <b>Pay Frequency</b> field.</p> <p>Minimum pay can be used to screen applicants. It is compared to the <b>Maximum Salary</b> field on the job opening.</p>
<b>Desired Shift</b>	<p>If the applicant wants shift work, select the appropriate shift from the available options. Selecting the <b>Not Applicable</b> check box causes the system to deselect all other shift check boxes. Likewise, selecting anything other than <b>Not Applicable</b> causes the system to deselect the <b>Not Applicable</b> check box.</p> <p>This field can be used to screen applicants. It is compared to the <b>Shift</b> field on the job opening.</p>
<b>Desired Hours Per Week</b>	<p>Enter the number of hours per week that the applicant prefers to work.</p> <p>This field can be used to screen applicants. It is compared to the <b>Standard Hours/Week</b> field on the job opening.</p>

## Application Acknowledgement Letter

<i>Field or Control</i>	<i>Description</i>
<b>Letter</b>	<p>Select a letter template for generating a form letter to send to the applicant. The system generates letters using Oracle Business Intelligence Publisher (BI Publisher) for PeopleSoft. The letters that are available for selection are those with the report definition HRS_APP_LET.</p> <p>Unless you manually generate the letter, saving a letter template for an application adds the letter to the queue of the Print Recruitment Letters batch process.</p> <p>See <a href="#">Sending Correspondence and Recruitment Letters</a>.</p>

<b>Field or Control</b>	<b>Description</b>
<b>Generate Letter</b>	<p>This link is available only if a letter template is selected. Click the link to generate the letter. The system opens the letter in a new window, where you can review it, save it locally, and optionally modify it. Once you generate a letter, you are responsible for printing and sending it; generating the letter removes it from the queue of the Print Recruitment Letters batch process.</p> <p>When you generate a letter, the system populates the <b>Date Letter Printed</b> field with the system date and adds the letter to the <b>Contact History</b> grid on the <a href="#">Manage Applicant Page: Notes Tab</a>.</p>
<b>Date Printed</b>	<p>Displays the date that the letter was printed. The system automatically populates this field after you manually generate the letter or when the Print Recruitment Letters batch process prints the letter.</p>

### Referral Source

Use this group box to enter referral information for the applicant.

<b>Field or Control</b>	<b>Description</b>
<b>How did you learn of the job</b>	<p>Select a value that indicates how the employee learned about the job opening. Employee and Marketing type recruitment sources are available for selection.</p>
<b>Additional Information</b>	<p>If the referral source is a Marketing recruitment source for which subsources are defined, you can select a subsource to provide additional information about how the employee learned about the job opening.</p>
<b>Specific Referral Source</b>	<p>Enter freeform text with any additional information about how the employee learned about the job opening.</p>
<b>Empl ID, Referral Name, and Applicant is a Family Member</b>	<p>If the referral source is an Employee recruitment source, these fields appear. Use these fields to enter additional information about the employee that referred the applicant.</p> <p>The Referral Name is a freeform text field.</p>

See [Setting Up Recruitment Sources](#).

## Resume

<i>Field or Control</i>	<i>Description</i>
<b>Resume Title</b>	Enter a title for the resume. Applicants who use Candidate Gateway to apply can reuse existing resumes, and the resume title helps identify individual resumes.
<b>Language Code</b>	Select the language in which the resume is written. This field is informational only.

## Resume Attachment

<i>Field or Control</i>	<i>Description</i>
<b>File Name</b>	Applications can include a single resume attachment. If one exists, you can click the filename link to view the resume. The system opens the resume in a separate window.
<b>Add Resume Attachment</b>	Click to browse for and upload a resume. If a resume is already attached, this button is disabled. It becomes available again if you subsequently delete the resume attachment.

## Resume Text

If no resume text exists, the group box title is **No Resume Text**, and the group box is initially collapsed.

<i>Field or Control</i>	<i>Description</i>
<b>Resume Text</b>	<p>Enter or paste the text of the applicant's resume. Pasted text retains its original formatting. You can optionally format and spell-check resume text using the tools adjacent to the text field.</p> <p>It is possible to have both resume text and a resume attachment.</p>

## Attachments

This grid displays the applicant's non-resume attachments, including attachments that are specifically associated with this application and attachments that are associated with all applications.

<b>Field or Control</b>	<b>Description</b>
<b>Attachment</b>	Displays the file name of the attachment. Clicking this link opens the file.
<b>Attachment Title</b>	Enter a descriptive title for the attachment.
<b>Attachment Type</b>	<p>Select an attachment type. Attachment types are defined on the <a href="#">Attachment Type Setup Page</a>.</p> <p>Although Candidate Gateway requires applicants to select an attachment type for every file, this field is not required in Talent Acquisition Manager.</p> <p>The maximum number of attachments specified on the attachment type definition is not applicable when you enter attachments in Talent Acquisition Manager. (The maximum applies only to applicants who upload attachments using Candidate Gateway.)</p>
<b>Apply to All</b>	<p>Select this check box to indicate that the attachment is associated with the applicant rather than with this one job application. When this check box is selected, the attachment is visible in all of the applicant’s applications.</p> <hr/> <p><b>Important!</b> This check box is editable when you first upload a new attachment, but it becomes read-only after you save the page. If you forget to select the check box before saving, you can delete the attachment and start over.</p> <hr/>
<b>Last Updated</b>	Displays the date and time that the attachment information was last updated.
<b>Uploaded By</b>	<p>For attachments that were uploaded in Talent Acquisition Manager, this column displays the name of the user who uploaded the file.</p> <p>For attachments that were uploaded in Candidate Gateway, this column displays the applicant name. (However, in some older applications, attachments that were uploaded in Candidate Gateway show the name from the user ID that was used to access Candidate Gateway. For internal applicants, this is the applicant’s name. For external applicants, this is the name, if any, that is associated with the Candidate Gateway guest user ID. If there is no name associated with the guest user ID, this field is blank.)</p>

<b>Field or Control</b>	<b>Description</b>
<b>Add Attachment</b>	Click this button to open the File Attachment dialog box and upload a new attachment. The system adds a row to the Attachments dialog. In this new row, the <b>Apply to All</b> check box is editable at first, but it becomes read-only after you save the page.

## Work Experience

Use this grid to display and define the applicant's work experience.

For internal applicants, the system brings in prior work experience from employee’s Human Resources records (as seen on the “Prior Work Experience Page” (PeopleSoft Human Resources Administer Workforce)). You can add or remove work experience in the application without affecting the Human Resources data.

Unlike other types of application data, work experience that you add for internal applicant is not carried forward to subsequently created applications, which will show only the data from the Human Resources system.

<b>Field or Control</b>	<b>Description</b>
<b>Start Date</b> and End Date	<p>These fields show how long the applicant worked at a job.</p> <p>The system uses the start date and end date to calculate the applicant's years of work experience. When there is no end date, the system calculates the years of work experience through the current date.</p> <p>This information can be used to screen applicants. The calculated value is compared to the <b>Years of Work Experience</b> requirement entered in the <b>Work Experience &amp; Education</b> matrix on the job opening.</p> <hr/> <p><b>Note:</b> When the screening process evaluates whether an applicant meets particular education &amp; experience requirements, it fails applications where there are no work experience entries with start dates, even if there are zero years of work experience required.</p> <hr/>
<b>Employer</b> and <b>Ending Job Title</b>	These fields describe the applicant’s work experience.
 <b>Edit</b>	Click to open the Work Experience page where you can view and modify additional work experience details.

<b>Field or Control</b>	<b>Description</b>
<b>Add Work Experience</b>	Click to access the Work Experience page and enter additional work experience information.

### Education Level

<b>Field or Control</b>	<b>Description</b>
<b>Highest Education Level</b>	Select the highest level of education attained by the applicant.  The screening processes uses this field when determining whether an applicant has the minimum number of years of experience required of applicants with a particular level of education.

### Training

Use this grid to list relevant training courses that the applicant has taken. For each course, enter the course title, the school name, and the course date. Click the **Add Training** link to add a blank row to the grid so that you can enter another training course.

New applications for employees bring in default training data from the “Professional Training Page or Global Assignments Training Page” (PeopleSoft Human Resources Manage Profiles) in PeopleSoft Human Resources.

### <Profile Content Type>

Job applications include a separate grid for each profile content type in the system's primary person type profile. Grids appear alphabetically by content type code (which is different from the content type name that appears as the grid label).

<b>Field or Control</b>	<b>Description</b>
<b>&lt;Content Item Name&gt;</b>	In each content type grid, the first column displays the name of the specific content item that you added.  For example, in the Competencies grid, the first column (labeled <i>Competencies</i> ) displays a specific competency such as <i>Analytical Thinking</i> , while in the Degrees grid, the first column (labeled <i>Degrees</i> ) displays a specific degree name such as <i>Bachelor of Arts</i> .  To modify information about a content item that you have already added to the grid, click the value in this first column to access the corresponding detail page.



<b>Field or Control</b>	<b>Description</b>
<Additional Column Names>	The columns that appear in each grid depend on the settings in the <a href="#">Content Section Configuration – &lt;Content Type&gt; Page</a> . Specifically, fields for which you select the <b>Summary</b> check box on the Content Section Configuration page appear as grid columns.
Add <Content Item>	<p>Click this button to access the content item detail page, where you enter specific content items (such as <i>Analytical Thinking</i> and <i>Bachelor of Arts</i>). The fields on the detail page depend on the content type definition within the Manage Profiles business process.</p> <p>Save the data on the detail page to add the content item to the grid.</p> <hr/> <p><b>Note:</b> You can also import content items from associated job openings using the Import Ratable Profile Items button in the Job Openings grid on this page. That button loads content items for content types such as competencies that are configured so that applicants rate themselves on predefined content items.</p> <hr/>

### (USF) Priority Placement

This grid displays priority placement codes for the applicant.

This information, along with the salary grade and level, is used by the Priority Placement process to identify applicants who should be considered as a candidate for a specific job opening. This information is compared to the priority placement codes and salary information entered on the job opening.

<b>Field or Control</b>	<b>Description</b>
 <b>Edit</b>	Click to open the Priority Placement page where you can view and modify additional work experience details.
<b>Add Priority Placement</b>	Click to access the Priority Placement page and enter additional work experience information.

### (USF) Federal Preferences

Use this group box to enter federal preferences.

<b>Field or Control</b>	<b>Description</b>
<b>Federal Civilian Employee?</b>	<p>Select the appropriate check box to indicate whether the applicant is a current or previous employee of the federal government or an agency.</p> <p>This information can be used to screen applicants. The check boxes that are selected here are compared to the <b>Recruiting Type</b> field on the job opening.</p>
<b>Highest Pay Plan and Highest Grade</b>	Enter the applicant's highest pay plan or grade.
<b>Minimum Acceptable Pay Plan and Minimum Acceptable Grade</b>	<p>Select the minimum pay plan and grade that the applicant will accept.</p> <p>Minimum Acceptable Grade can be used to screen applicants. This field is compared to the <b>Minimum Pay Grade</b> field on the job opening.</p>
<b>Highest Career Tenure</b>	Select the applicant's highest career tenure. Values are <i>Conditional, Indefinite, None, and Permanent</i> .
<b>Veterans Preference</b>	Select the veterans hiring preference that applies. Veterans preference values are defined on the <a href="#">(USF) Setup Veterans Preference Page</a> .
<b>Reserve Category</b>	Select the employee's reserve category, or select <i>Not Applicable</i> .
<b>Uniformed Service</b>	Select the type of uniformed service in which this veteran served. Values are: <i>Air Force, Army, Coast Guard, Marines, and Navy</i> .
<b>Military Grade</b>	Select the veterans military grade.
<b>Military Separation Status</b>	Select the veterans military separation status.
<b>Military Service Start Date and End Date</b>	Enter the applicant's military service dates.
<b>Creditable Military Service</b>	Enter the amount of military service for which the applicant receives credit.
<b>Military Service Verified</b>	Select this check box if you have verified the applicant's military service.

<b>Field or Control</b>	<b>Description</b>
<b>Veterans Preference RIF</b> (Veterans Preference in Reduction in Force)	Select this check box if the applicant is eligible for veterans preference in RIF.
<b>Effective Date</b>	Enter the effective date for the applicant's military status.
<b>Military Status</b>	Select the applicant's military status.

## View Questionnaire Page

Use the View Questionnaire page (HRS\_APP\_QSTN\_RSLT) to review an applicant's answers to a completed questionnaire.

Navigation:

Click the **View Questionnaire** link in the Job Openings grid on the Application Details page.

The link appears only for job openings that are associated with screening questions. The link is active only if the applicant has completed the questionnaire (which means it is never available when a user is adding a new applicant on the Create Applicant page).

This example illustrates the View Questionnaire Page.

### View Questionnaire

Nora Dooley

**Applicant ID** 300235

**Job Opening** 300269      Customer Service Representative

**Question** 1004      Are you willing to work overtime periodically ?

Answers		
1027	No	<input type="checkbox"/>
1037	Yes	<input checked="" type="checkbox"/>

**Question** 1036      Are you 21 years of age or older?

Answers		
1009	Yes	<input checked="" type="checkbox"/>
1025	No	<input type="checkbox"/>

**Question** 3008      What qualities or skills do you possess that have helped you deal with unsatisfied customers in the past?

Answers	
	Patience and empathy are qualities that help me to work effectively with a customer who is initially dissatisfied. Superior troubleshooting skills and a strong focus on results help me to resolve issues and make unsatisfied customers into satisfied customers.

**Evaluators for the Open Ended Question**

**Average Review Points** 3

Evaluator Response			
Empl ID	Name		Points for Answer
KU0003	Jean Parsons		<input type="text"/>
KU0007	Betty Locherty		3 <input type="text"/>

Apply

Save and Return

Close

This page shows the questions that are associated with the job opening along with any answers that the applicant provided while applying (including questions that were answered during prescreening).

### Questions and Answers

For each multiple-choice question, the page displays the possible answers; a selected check box indicates the applicant's answer.

## Evaluators for the Open Ended Question

Following each open-ended questions, the page displays a list of assigned evaluators, and the score assigned by each evaluator. Evaluators can use this grid to award points to the answer. The **Average Review Points** field shows the average of all submitted evaluations.

### Buttons

<i>Field or Control</i>	<i>Description</i>
<b>Apply and Save and Return</b>	If the page includes an editable field for entering points for an open-ended question, use the <b>Apply</b> button to save the change without leaving the page, or use the <b>Save and Return</b> button to save the change and return to the Edit Application Details page. Neither button appears if there are no open-ended questions with evaluators.
<b>Close</b>	Click to return to the Edit Application Details page. Changes to the points for open-ended questions are not saved.

## Work Experience Page

Use the Work Experience page (HRS\_APP\_WRK\_SEC) to enter work experience information.

The page title is either Add Work Experience or Edit Work Experience, depending on context.

Navigation:

On the Application Details page, click the **Add Work Experience** button or click the **Edit Employment History** icon for an existing record.

This example illustrates the Work Experience Page.

<b>Field or Control</b>	<b>Description</b>
<b>Start Date and End Date</b>	These dates determine the number of years of experience represented by this entry. When the end date is blank, work experience is calculated through the current date.
<b>Relevant Work Experience</b>	<p>Select this check box if the screening process should consider this work experience when evaluating whether the applicant has the required years of experience for a particular level of education. The screening process ignores entries where this check box is not selected.</p> <p>When this check box is selected, the <b>Years of Relevant Work Experience</b> field appears and displays a system-calculated value.</p>

Address fields (with lookup) appear as drop-down by default. However, this configuration can be changed from the framework using the Country Format setup. For more information, see “Entry and Validation Page” (Application Fundamentals)

## <Content Type> Page for Applicants

Use the <Content Type> page for applicants (HRS\_APP\_DETAIL) to add or update applicant profile information such as competencies, degrees, licenses & certificates, language skills, and so forth. The page title depends on the type of profile content you are entering and whether you are adding or editing data.

Navigation:

- Click the **Add <Content Type>** button under a content type grid on the Application Details page.
- Click the **Edit** icon for an existing entry in any content type grid on the Application Details page

This example illustrates the Add Competencies page.

**Add Competencies**

\*Effective Date 12/29/2012

\*Competency

\*Evaluation Type

Reviewer ID

\*Rating Model PSCM Competency Management Scale

\*Proficiency

Verified By

Interest Level

EmplID

Year Last Used

Reviewer Is Approved

Year Acquired

Years Of Experience

Review Active

Review Date

Description

Reviewer

Long Description

Save Save and Add Another Cancel

This example illustrates the Add Language Skills page.

The screenshot shows a dialog box titled "Add Language Skills". At the top, there is a field for "\*Evaluation Date" with the value "12/29/2012" and a calendar icon. Below it is a field for "\*Language" with a search icon. The "Rating Model" is set to "LANG". Under the heading "Language Ratings", there are three dropdown menus for "Reading Proficiency", "Speaking Proficiency", and "Writing Proficiency". At the bottom, there are three checkboxes: "Native Language", "Able To Translate", and "Able To Teach". At the very bottom, there are three buttons: "Save", "Save and Add Another", and "Cancel".

The fields on the content type detail pages depend on the content type configuration in the Manage Profiles business process and on the Content Section Configuration – <Content Type> Page.

<b>Field or Control</b>	<b>Description</b>
<b>Save</b>	Click to save the current content item and return to the Application Details page.
<b>Save and Add Another</b>	Click to save the current content item and clear the page so that you can enter information about a new content item. The saved content item will become visible on the Application Details page after you close the dialog box.
<b>Cancel</b>	Click to close the dialog box and return to the Application Details page without saving the current content item. Any content items that you previously saved using the <b>Save and Add Another</b> button are not canceled.

## (USF) Priority Placement Page

Use the Priority Placement page (HRS\_CE\_ADM\_PP) to add or edit an applicant’s priority placement information for U.S. federal implementations.

Navigation:

Click the **Add Priority Placement** button or the **Edit** icon on the Application Details page.



This example illustrates the Priority Placement Page.

The screenshot shows a web form titled "Add Priority Placement" with a close button in the top right corner. The form contains the following fields and controls:

- Priority Placement End Date:** A text input field followed by a calendar icon.
- Priority Placement Code:** A dropdown menu.
- Pay Plan:** A text input field followed by a search icon.
- Occupational Series:** A text input field followed by a search icon.
- Salary Grade:** A text input field followed by a search icon.
- Comment:** A large text area with a help icon and a save icon in the top right corner.

At the bottom of the form are two buttons: "Save" and "Cancel".

The Priority Placement process uses priority placement information to identify applicants who should be considered as a candidate for a specific job opening. The applicant's priority placement information is compared to the priority placement codes and salary information entered on the job opening.



## Chapter 20

# Searching for and Managing Applicants

## Performing Applicant and Profile Searches

This topic provides an overview of applicant searches and discusses how to search or browse for applicants.

### Pages Used to Search for Applicants

<i>Page Name</i>	<i>Definition Name</i>	<i>Usage</i>
<a href="#">Search Applicants Page</a>	HRS_REC_SCHAPP	Use any of the following to search for applicants and perform applicant-related actions: <ul style="list-style-type: none"><li>• <a href="#">Search Applicants Page: Quick Search Tab</a></li><li>• <a href="#">Search Applicants Page: Keyword Search Tab</a></li><li>• <a href="#">Search Applicants Page: Advanced Search Tab</a></li><li>• <a href="#">Search Applicants Page: Profile Match Tab</a></li></ul>
<a href="#">Compare Results Page</a>	HRS_COMPARE_RES	Review a detailed profile comparison based on the results of a profile search. The page always displays the profile that you were trying to match; you select rows from the search results to compare to that profile.
<a href="#">Browse Applicants Page</a>	HRS_APPLICANT_SRCH	Search for applicants using a combination of keyword searching and faceted filtering.

### Understanding Applicant Searches

The following table describes the pages you can use to search for applicants and identifies the PeopleTools Search Framework search definition that you must deploy and build for each search.

<b>Search Page</b>	<b>Description</b>	<b>PeopleTools Search Framework Search Definition</b>
Search Applicants: Quick Search	<p>This is a basic database search that looks for selected values in specific applicant data fields. It does not search any job application fields (other than the date on which the application was received). Rather, it searches non-application data such as the applicant status, type, disposition, and so forth.</p> <p>This search is not suitable for finding applicants with specific qualifications. It is most useful for quickly accessing a known applicant.</p>	None
Search Applicants: Keyword Search	<p>This search uses the PeopleTools Search Framework to look for keywords that appear in an applicant’s resume or in the actual job application (as shown on the <a href="#">Application Details Page</a>).</p> <p>An applicant who submitted multiple applications or resumes can appear in the search results multiple times. However, the results include only one row per application, regardless of how many job openings the application is associated with.</p>	HC_HRS_APP_INDEX
Search Applicants: Advanced Search	<p>The advanced applicant search expands the keyword search by offering additional search criteria fields, including general applicant data (such as the applicant type or status) and data in the job application.</p> <p>If you enable profile integration on the <a href="#">Recruiting Installation - General Page</a>, the advanced search also enables you to prepopulate data into profile-related search criteria by importing the information from an existing employee profile, a job opening, or a non-person profile.</p>	HC_HRS_APP_INDEX
Search Applicants: Profile Match	<p>The profile match search uses the PeopleTools Search Framework to search for applicants, employees, job openings, and non-person profiles with profile data that matches a specified applicant, employee, job opening, or non-person profile.</p> <p>For example, to find candidates for a job opening, you could search for applicants and employees with profiles that match the job opening profile. You can similarly search for suitable job openings for a particular applicant, or for applicants who are similar to a particular employee.</p> <p>When you perform a profile match, you do not choose which profile content to search for. Instead, the system considers all content that is associated with the profile.</p> <p>Profile Match searching is available only if you activate profile integration on the <a href="#">Recruiting Installation - General Page</a>. Employee profile searching is available only if person profile integration is activated.</p> <hr/> <p><b>Note:</b> When you use a profile match search to search for employees who match a job opening, the system provides an option to generate email suggesting to selected employees that they apply for the job opening. Until the employee applies, there is no applicant record for the employee, and you cannot perform any recruiting actions related to the employee.</p>	HC_HRS_APPLICATION_CONTENT HC_HRS_JOB_CONTENT HC_JPM_PERSON_PROFILE HC_JPM_NONPERSON_PROFILE

<b>Search Page</b>	<b>Description</b>	<b>PeopleTools Search Framework Search Definition</b>
Browse Applicants	The Browse Applicants page uses the PeopleTools Search Framework to enable users to search for applicants using a combination of keyword searching and faceted filtering.	HC_HRS_APPLICANT

## Search Applicants Page

Use the Search Applicants page (HRS\_REC\_SCHAPP) to search for applicants using any of four search options.

Navigation:

**Recruiting > Search Applicants**

This example illustrates the Search Applicants page.

## Toolbar

<b>Field or Control</b>	<b>Description</b>
<b>Recruiting Home</b>	Click to access the <a href="#">Recruiting Home Page</a> .
<b>Browse Applicants</b>	Click to access the <a href="#">Browse Applicants Page</a> .
<b>Saved Searches</b>	Click to access the <a href="#">Saved Searches Page</a> .

## Search Tabs

<i>Field or Control</i>	<i>Description</i>
<b>Quick Search</b>	Use the <a href="#">Search Applicants Page: Quick Search Tab</a> to perform a basic database search that looks for selected values in specific applicant data fields. It does not search any job application fields.
<b>Keyword Search</b>	Use the <a href="#">Search Applicants Page: Keyword Search Tab</a> to search for applicants based on keywords that appear in the applicant's resume or job application
<b>Advanced Search</b>	Use the <a href="#">Search Applicants Page: Advanced Search Tab</a> to search for applicants using a broad set of search criteria fields, including general applicant data (such as the applicant type or status) and data in the job application.
<b>Profile Match</b>	Use the <a href="#">Search Applicants Page: Profile Match Tab</a> to search for applicants, employees, job openings, and non-person profiles with profile data that matches a specified applicant, employee, job opening, or non-person profile.  This tab is visible only if the <b>Allow Profile Utilization</b> field on the <a href="#">Recruiting Installation - General Page</a> is set to <i>Yes</i> .

### Search Applicants Page: Quick Search Tab

Use the Search Applicants page: Quick Search tab (HRS\_REC\_SCHAPP) to perform a basic database search that looks for selected values in specific applicant data fields.

Navigation:

**Recruiting > Search Applicants**

This example illustrates the Quick Search tab on the Search Applicants page.

The screenshot shows the 'Search Applicants' interface. At the top, there are navigation links: 'Recruiting Home', 'Browse Applicants', and 'Saved Searches'. Below these are four tabs: 'Quick Search' (selected), 'Keyword Search', 'Advanced Search', and 'Profile Match'. The 'Search Criteria' section is expanded, showing a 'Search My Applicants' checkbox which is checked. Below this are several input fields: 'First Name' (containing 'BEN'), 'Last Name', 'Display Name', 'Alternate Character Name', 'Applicant Status' (set to '010 Active'), 'Applicant Type', 'Applied Within', 'Applied Between' (with calendar icons), 'Job Opening ID' (with a search icon), and 'Applicant ID'. 'Search' and 'Clear' buttons are at the bottom of the criteria section. Below the criteria, it says '2 Result(s) Found' and 'Search Results'. A table displays the results with columns for Select, Applicant, Applicant ID, Type, Status, Phone, Email Address, Date Applied, Jobs Applied, and Actions. Two results are shown: Bena Orrtha and Benita Zingaro.

Select	Applicant	Applicant ID	Type	Status	Phone	Email Address	Date Applied	Jobs Applied	Actions
<input type="checkbox"/>	Bena Orrtha	300120	External Applicant	010 Active			03/03/2009	1	▼ Actions
<input type="checkbox"/>	Benita Zingaro	500272	External Applicant	010 Active	589/300-6959	benita.zingaro@oraclesample.com	15/06/2012	3	▼ Actions

### Search Criteria

Use this group box to enter criteria. After you perform a search, this section is collapsed. You can expand the section to modify your search criteria and perform another search.

<b>Field or Control</b>	<b>Description</b>
<b>Search My Applicants</b>	<p>Select this check box if you want to see only the applicants that are attached to job openings where you are either the originator or part of the hiring team. Applicants that you enter into the system are not considered your applicants unless they are associated with one of your job openings.</p> <p>If the check box is not selected:</p> <ul style="list-style-type: none"> <li>• Under standard applicant security, all applicants in the system are potential search results.</li> <li>• Under enhanced applicant security, the only additional applicants that the user has access to are applicants who applied without a job opening.</li> </ul> <p>See <a href="#">Understanding Enhanced Applicant Security</a>.</p> <p>On the Quick Search tab, which is most useful for finding known applicants, this check box is initially deselected.</p>

<b>Field or Control</b>	<b>Description</b>
<b>First Name, Last Name, and Display Name</b>	To search by name, enter a full or partial first name, last name, or display name.
<b>Applicant Status</b>	Choose an applicant status to use as search criteria. The default value is the status identified as the default applicant status on the <a href="#">Recruiting Status Area Page</a> . As delivered, the default status is <i>Active</i>
<b>Applicant Type</b>	Select <i>Employee</i> , <i>External Applicant</i> , or <i>Non-Employee</i> .  Non-employees are applicants who, although not current employees, already have data in the PeopleSoft HCM system.
<b>Applied Within</b>	To limit the search to applications that were received within a specific time frame, select one of these time frames: <i>010 - Today</i> , <i>020 - Yesterday</i> , <i>030 - Last 3 Days</i> , <i>040 - Last Week</i> , <i>050 - Last 2 Weeks</i> , <i>060 - Last Month</i> , <i>070 - Last Year</i> , or <i>080 - View All</i>
<b>Applied Between</b>	Enter a date range for searching based on when an application was received.
<b>Job Opening ID</b>	When you enter a job opening ID, the search results include only applicants who are associated with that job opening.
<b>Applicant ID</b>	For security reasons, the system does not allow users to prompt for applicant IDs. To search for an applicant using the applicant ID, type the ID into this field.
<b>Search</b>	Click to run the search.
<b>Clear</b>	Click to restore the default search criteria. The system selects the <b>Search My Applicants</b> check box, restores the default value to the <b>Applicant Status</b> field, and clears all other fields.

## Search Results

<b>Field or Control</b>	<b>Description</b>
<b>Select</b>	Before performing a group action, use this check box to select the applicants to which the group action applies.



<b>Field or Control</b>	<b>Description</b>
<b>Applicant</b>	Displays the applicant's name. Click the link to access the <a href="#">Manage Applicant Page</a> .
<b>Applicant ID</b>	Displays the applicant's unique identifier.
<b>Type</b>	Displays <i>External Applicant</i> , <i>Employee</i> , or <i>Non-Employee</i> .
<b>Status</b>	Displays the applicant's overall status (not the applicant's disposition for any particular job opening).
<b>Phone</b>	Displays the applicant's primary phone number, if one exists.
<b>Email Address</b>	Displays the applicant's primary email address, if one exists.
<b>Date Applied</b>	Displays the date of the applicant's most recent application.
<b>Jobs Applied</b>	Displays the number of jobs that the applicant has applied for. The count does not include any applications in draft status such as unsubmitted applications that the applicant started in Candidate Gateway.
<b>Actions</b>	<p>Click to display a menu of actions that you can perform for the applicant shown in the row. The following actions are available in this context:</p> <ul style="list-style-type: none"> <li>• Add Applicant to List</li> <li>• Change Applicant Status</li> <li>• Forward Applicant</li> <li>• Link Applicant to Job</li> <li>• Send Correspondence</li> </ul> <p>See <a href="#">Understanding Actions for Managing Applicants</a>.</p>

## Group Actions

<b>Field or Control</b>	<b>Description</b>
<b>Select All and Deselect All</b>	Use these links to select or deselect grid rows so that you can perform group actions on the selected rows.

<b>Field or Control</b>	<b>Description</b>
<b>Group Actions</b>	<p>Click to display a menu of group actions that you can perform for the selected applicants. The list of available group actions is the same as the list of actions that are available from the <b>Actions</b> menu for a single row.</p> <hr/> <p><b>Note:</b> The number of rows that can be included in a group action can be limited using the Group Action Limit field on the <u>Recruiting Installation – Applicants Page</u>. If a user attempts to perform a group action when too many rows are selected, the system displays a message informing the user of the limit and stating that only the allowed number of rows will be processed. If the user continues, the system processes the allowed number of rows, starting at the beginning of the list and following the grid sort order. Even if the user cancels, the system deselects all rows after the specified limit, and the user can review which rows will be processed before re-initiating the action with an allowable number of selected rows.</p>

## Search Applicants Page: Keyword Search Tab

Use the Search Applicants page: Keyword Search tab (HRS\_REC\_SCHAPP) to search for applicants based on keywords that appear in the applicant’s resume or job application.

Navigation:

**Recruiting > Search Applicants**

Click the Keyword Search tab.

This example illustrates the Keyword Search tab on the Search Applicants page.

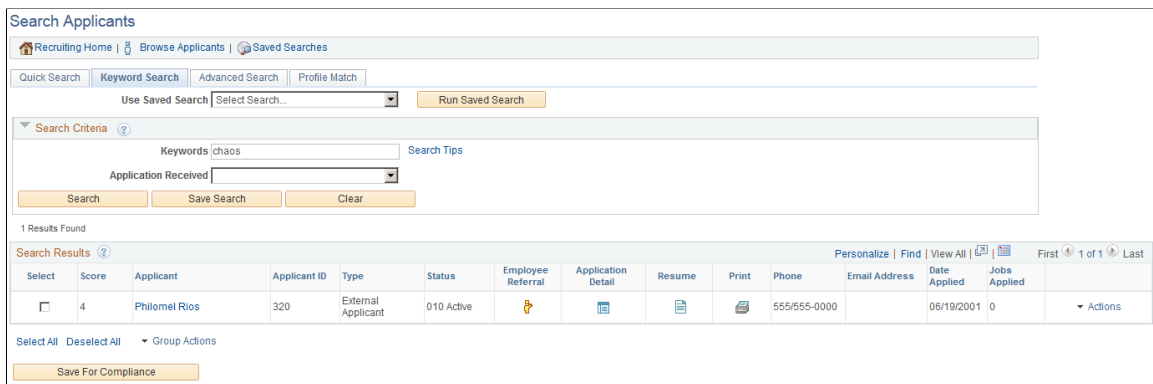

**Note:** Additional fields and buttons for editing a saved search appear if you access this page by clicking a saved search name on the Saved Searches Page. For information about these additional elements, see Search Applicant Page: Editing Saved Search Mode

## Running Saved Searches



<i>Field or Control</i>	<i>Description</i>
<b>Use Saved Search</b>	To run a saved search, first select the search from this drop-down list box.  The list of available saved searches includes only keyword searches. The list includes public searches as well as private advanced searches that you created.
<b>Run Saved Search</b>	Click to run the saved search that you selected.

## Search Criteria

<i>Field or Control</i>	<i>Description</i>
<b>Keywords</b>	Enter any words or phrases that you want the system to look for in applicant's resumes. The system searches for the keywords in the application data and in any attached resume file.
<b>Search Tips</b>	Click to view tips for constructing keyword searches. For example, the tips explain how to search for phrases and how to indicate whether you want to search for applications with all keywords or any keyword.
<b>Application Received</b>	To limit the search to applications that were received within a specific time frame, select one of these time frames: <i>Within Last Day</i> , <i>Within Last Week</i> , <i>Within Last Month</i> , <i>Within Last Year</i> , and <i>Anytime</i> .
<b>Search</b>	Click to perform the search.
<b>Save Search</b>	Click to save your search criteria.
<b>Clear</b>	Click to restore the default search criteria. The system clears the <b>Keywords</b> field and sets the <b>Application Received</b> field to <i>Anytime</i> .

## Search Results

The search results grid for a keyword search contains the same information as the results of a Quick Search along with these additional fields:

<b>Field or Control</b>	<b>Description</b>
<b>Score</b>	Displays a score that represents how closely the application matches your search criteria.
 <b>Employee Referral</b>	Displays the Employee Referral icon if the applicant was referred by an employee.
 <b>Application Detail</b>	Click to open a new window that displays the <a href="#">Application Details Page</a> , where you can review the applicant's complete job application.
<b>Resume</b>	<p>Click to open a new window that displays the applicant's resume.</p> <ul style="list-style-type: none"> <li>• If the resume is an attachment, the file opens in the new window.</li> <li>• If the resume was entered into the <b>Resume Text</b> field in the application, the new window displays the <a href="#">Applicant Resume Page</a>.</li> <li>• If no resume exists for a particular applicant, then this column is blank.</li> </ul> <p>If none of the applicants in the grid have resumes, the entire Resume column is hidden.</p>
 <b>Print</b>	Click to access the <a href="#">Application Report Options Page</a> , where you can choose report parameters and then generate an application details report.
<b>Actions</b>	<p>Click to display a menu of actions that you can perform for the applicant shown in the row. The following actions are available in this context:</p> <ul style="list-style-type: none"> <li>• Add Applicant to List</li> <li>• Change Applicant Status</li> <li>• Forward Applicant</li> <li>• Link Applicant to Job</li> <li>• Send Correspondence</li> </ul> <p>See <a href="#">Understanding Actions for Managing Applicants</a>.</p>

The search results grid includes an additional hidden column that displays a Former Employee icon for applicants who indicate that they are former employees. To display this additional column, use PeopleTools Application Designer to modify the grid definition.

## Group Actions

<i>Field or Control</i>	<i>Description</i>
<b>Select All</b> and <b>Deselect All</b>	Use these links to select or deselect grid rows so that you can perform group actions on the selected rows.
<b>Group Actions</b>	<p>Click to display a menu of group actions that you can perform for the selected applicants. The list of available group actions is the same as the list of actions that are available from the <b>Actions</b> menu for a single row.</p> <hr/> <p><b>Note:</b> The number of rows that can be included in a group action can be limited using the Group Action Limit field on the <a href="#">Recruiting Installation – Applicants Page</a>. If a user attempts to perform a group action when too many rows are selected, the system displays a message informing the user of the limit and stating that only the allowed number of rows will be processed. If the user continues, the system processes the allowed number of rows, starting at the beginning of the list and following the grid sort order. Even if the user cancels, the system deselects all rows after the specified limit, and the user can review which rows will be processed before re-initiating the action with an allowable number of selected rows.</p> <hr/>

## Save for Compliance

<i>Field or Control</i>	<i>Description</i>
<b>Save for Compliance</b>	<p>Click this button, which appears below the search results after you perform a search, to save the search results (not the search criteria) for auditing and statutory reporting purposes. When you save results for compliance, the results set cannot be deleted.</p> <p>There is a setting on the <a href="#">Recruiting Installation – Jobs Page</a> page that can force saving when the search criteria includes a job opening.</p>

## Search Applicants Page: Advanced Search Tab

Use the Search Applicants page: Advanced Search tab (HRS\_REC\_SCHAPP) to search for applicants using a broad set of search criteria fields, including general applicant data (such as the applicant type or status) and data in the job application.

Navigation:

**Recruiting > Search Applicants**

Click the Advanced Search tab.

This is the first of two examples illustrating the Advanced Search tab on the Search Applicants page.

This is the second of two examples illustrating the Advanced Search tab on the Search Applicants page.

**Note:** Additional fields and buttons for editing a saved search appear if you access this page by clicking a saved search name on the [Saved Searches Page](#). For information about these additional elements, see [Search Applicant Page: Editing Saved Search Mode](#)

## Running Saved Searches

<i>Field or Control</i>	<i>Description</i>
<b>Use Saved Search</b>	<p>To run a saved search, first select the search from this drop-down list box.</p> <p>The list of available saved searches includes only advanced searches. The list includes public searches as well as private advanced searches that you created.</p>
<b>Run Saved Search</b>	Click to run the saved search that you selected.

## Buttons

<i>Field or Control</i>	<i>Description</i>
<b>Search</b>	Click to perform the search.
<b>Save Search</b>	Click to save your search criteria.
<b>Clear</b>	Click to restore the default search criteria. For advanced searches, clicking this button sets the <b>Find Applicants Matching</b> field to <i>All Search Criteria</i> , selects all of the check boxes in the Applicant Type group box, and clears all other fields and check boxes.

## Search Criteria

<i>Field or Control</i>	<i>Description</i>
<b>Search My Applicants</b>	<p>Select this check box if you want to see only the applicants that are attached to job openings where you are either the originator or part of the hiring team. Applicants that you enter into the system are not considered your applicants unless they are associated with one of your job openings.</p> <p>If the check box is not selected, the system looks at all applicants that match your search criteria, including applicants who applied without a job opening.</p> <p>On the Advanced Search tab, which is most useful for finding applicants based on their qualifications, this check box is initially deselected.</p>

<b>Field or Control</b>	<b>Description</b>
<b>Find Applicants Matching</b>	Choose whether applicants must match <i>All Search Criteria</i> or <i>Any Search Criteria</i> . The default value is <i>All Search Criteria</i> .
<b>Application Date Range</b>	Enter a date range for searching based on when an application was received.
<b>Job Family</b>	<p>Select a job family; the system searches for applications that list this job family.</p> <p>Applicants who apply using Candidate Gateway cannot include job families in their applications. The only page where you can associate applications with job families is the <a href="#">Application Details Page</a>.</p>
<b>Recruiting Location</b>	Select a recruiting location; the system searches for applications that specify this location as either a first or second choice location.
<b>Country, State, and City</b>	Enter geographical search criteria; the system searches for applicants with addresses in the country, state, and city that you specify.
<b>Referral Source</b>	Select a referral source. The system limits the search results to applications that are associated with the specified source.
<b>Referral SubSource</b>	Select a referral subsourse. The options in this field depend on the referral source that you selected.
<b>Keywords</b>	Enter any words or phrases that you want the system to look for in applicant's resumes. The system searches for the keywords in the application data and in any attached resume file.
<b>Search Tips</b>	Click to view tips for constructing keyword searches. For example, the tips explain how to search for phrases and how to indicate whether you want to search for applications with all keywords or any keyword.



<b>Field or Control</b>	<b>Description</b>
<b>Applicant Type</b>	<p>Select the check boxes next to the types of applicants to include in the search. Options are:</p> <ul style="list-style-type: none"> <li>• External Applicant</li> <li>• Employee</li> <li>• Non-Employee</li> </ul> <p>By default, all three check boxes are selected.</p>
<b>Exclude Applicant Status from Search</b>	<p>Select the check boxes for any applicant statuses to be excluded from your search results.</p> <p>Regardless of which check boxes you select, the search results include only applicants with the statuses that were included in the index based on settings on the <a href="#">Build Search Index Settings Page</a>. For example, if the index includes only active applicants, but you attempt to search for inactive applicants by excluding all statuses other than <i>Inactive</i>, then the search results will be empty.</p>

### Profile Criteria

<b>Field or Control</b>	<b>Description</b>
<b>Profile Criteria From</b>	<p>When you enter search criteria, you can optionally import profile-related search criteria from a profile that you choose. To do this, use the <b>Profile Criteria From</b> field to select the type of profile to use. The available options depend on the profile integration settings on the <a href="#">Recruiting Installation - General Page</a>:</p> <ul style="list-style-type: none"> <li>• <i>Job Opening</i> is always available.</li> <li>• <i>Profile</i> (non-person profile) is available only if <b>Allow Profile Utilization</b> is set to <i>Yes</i>.</li> <li>• <i>Employee</i> is available only if <b>Person Profile Integration</b> is set to <i>Yes</i>.</li> </ul> <p>Depending on your selection, either the <b>Job Opening ID</b>, <b>Employee ID</b>, or <b>Profile ID</b> field appears so that you can identify a the specific profile to use.</p>

<b>Field or Control</b>	<b>Description</b>
<b>Employee ID</b>	<p>This field appears only if you select <i>Employee ID</i> in the <b>Profile Criteria From</b> page.</p> <p>Select an employee ID, and the system enters items from the employee's primary person profile into the profile-specific search criteria fields on this page.</p> <p>Standard profile security applies, preventing users from selecting profiles unless they have security access to the profile.</p>
<b>Job Opening ID</b>	<p>This field appears only if you select <i>Job Opening</i> in the <b>Profile Criteria From</b> page.</p> <p>Select a job opening ID, and the system enters items from the job opening's profile into the profile-specific search criteria fields on this page. This occurs regardless of whether profile utilization is activated on the Recruiting Installation - General page.</p> <p>If the Enforce Search Save field on the <a href="#">Recruiting Installation – Jobs Page</a> is set to <i>Yes</i>, then users are forced to save their search criteria any time they perform a search where a job opening ID is specified. Additionally, after saving the criteria and performing the search, the system displays a message reminding the user to save the search results using the Save for Compliance button at the bottom of the page.</p> <p>Entering a job opening ID causes three additional check boxes appear immediately below the Job Opening ID field. Advanced Search tab. Use these check boxes to indicate how to use the job opening in the search.</p>
Profile ID	<p>This field appears only if you select <i>Profile</i> in the <b>Profile Criteria From</b> page.</p> <p>Select a non-person profile, and the system enters items from the profile into the corresponding search criteria fields.</p>

### Additional Job Opening Search Settings

These check boxes are visible if the **Profile Criteria From** field is *Job Opening* and there is a value in the Job Opening ID field.

<b><i>Field or Control</i></b>	<b><i>Description</i></b>
<b>Display applicants associated to the Job Opening</b>	Select this check box to limit search results to applicants who are associated with the job opening.
<b>Expressed interest in the same Job Family as the Job Opening is in</b>	Select this check box to search for employees whose applications list the job family to which the selected job belongs.  Applicants who apply using Candidate Gateway cannot include job families in their applications. The only page where you can associate applications with job families is the <a href="#">Application Details Page</a> .
<b>Keywords that match the job description</b>	Select this check box to search applicant resumes for words that are in the primary job posting title.

### **Qualification-Related Search Criteria**

The Advanced Search offers several search criteria fields for searching for applicants with specific qualifications. Because Talent Acquisition Manager uses profiles to store applicant qualifications, the specific search fields that appear vary depending on how profiles have been configured for the recruiting process.

<b><i>Field or Control</i></b>	<b><i>Description</i></b>
<b>Work Experience</b>	Use this field to search for specific text in the Job Title and Employer Name fields of applicants' work experience records.

<b>Field or Control</b>	<b>Description</b>
<Profile Content Types>	<p>All fields after the Work Experience field correspond to profile content types that are used in Talent Acquisition Manger. If you selected a profile to use to prepopulate these fields (using the Job Opening ID field, the Employee ID field, or the Profile ID field), the system copies data from the source profile into the corresponding search criteria fields.</p> <p>The profile content fields that appear are the ones that:</p> <ul style="list-style-type: none"> <li>• Belong to the primary person profile type that you define on the <a href="#">Assign Profile Type Defaults Page</a> in PeopleSoft Human Resources Manage Profiles.</li> <li>• Are configured for use in recruiting on the <a href="#">Content Section Configuration – &lt;Content Type&gt; Page</a>.</li> <li>• Are configured for searching on the “Content Section Page” (PeopleSoft Human Resources Manage Profiles) in the Profile Types component.</li> </ul>

### Search Results

The search results grid for an advanced search is the same as the search results grid for a keyword search.

### Search Applicants Page: Profile Match Tab

Use the Search Applicants page: Profile Match tab (HRS\_REC\_SCHAPP) to search for applicant, employee, job opening, or non-person profiles that match a specific applicant, employee, job opening, or non-person profile.

---

**Note:** This tab is visible only if the Allow Profile Utilization field on the [Recruiting Installation - General Page](#) is *Yes*.

---

Navigation:

**Recruiting > Search Applicants**

Click the **Profile Match** tab.

This example illustrates the Profile Match tab on the Search Applicants page. This example shows applicants in the search results, but this page can also be used to search for employees, job openings, and non-person profiles.

The screenshot shows the 'Search Applicants' interface. At the top, there are navigation links: 'Recruiting Home', 'Browse Applicants', and 'Saved Searches'. Below this, there are search tabs: 'Quick Search', 'Keyword Search', 'Advanced Search', and 'Profile Match'. The 'Profile Match' tab is selected. A dropdown menu shows 'Use Saved Search' with a 'Select Search...' option and a 'Run Saved Search' button. The 'Search Criteria' section includes a dropdown for 'Search Based On The' set to 'Job Opening', a text input for 'With Job Opening ID' containing '300269', and a dropdown for 'And Find Similar' set to 'Applicants'. There are 'Search', 'Save Search', and 'Clear' buttons. Below the criteria, it says '5 Results Found'. The 'Search Results' table has columns: Select, Score, Applicant ID, Type, Applicant, Status, Application Detail, Print, Phone, Email Address, Date Applied, and Jobs Applied. The results are as follows:

Select	Score	Applicant ID	Type	Applicant	Status	Application Detail	Print	Phone	Email Address	Date Applied	Jobs Applied
<input type="checkbox"/>	100	500064	Employee	Allan Martin	010 Active			925/694-7912		06/14/2009	0 ▾ Actions
<input type="checkbox"/>	100	500117	Employee	Angela McKay	010 Active			925/694-7969		06/15/2009	0 ▾ Actions
<input type="checkbox"/>	100	500148	Employee	Cynthia Adams	010 Active			925/694-7901		06/15/2009	0 ▾ Actions
<input type="checkbox"/>	100	300024	External Applicant	Guy Francon	010 Active					01/13/2009	0 ▾ Actions
<input type="checkbox"/>	100	500102	Employee	Stanley Lowe	010 Active			925/694-7954		06/15/2009	0 ▾ Actions

At the bottom of the results, there are buttons for 'Select All', 'Deselect All', 'Compare', and 'Group Actions'. A 'Save For Compliance' button is also present.

This example shows the results of a search for employees with profiles similar to a specified job opening. Notice that the Actions related action menu is not visible. Instead, there is an Invite Application icon, because inviting an application is the only action that is relevant to employees who have been matched to job openings.

The screenshot shows a 'Search Results' table with 3 results found. The table has columns: Select, Score, Employee ID, Name, and Invite Application. The results are as follows:

Select	Score	Employee ID	Name	Invite Application
<input type="checkbox"/>	100	N9003	Dominique Francon	
<input type="checkbox"/>	100	N9004	William Hearst	
<input type="checkbox"/>	100	KU0119	Susan Hoinck	

At the bottom of the results, there are buttons for 'Select All', 'Deselect All', 'Compare', and 'Save For Compliance'.

**Note:** Additional fields and buttons for editing a saved search appear if you access this page by clicking a saved search name on the [Saved Searches Page](#). For information about these additional elements, see [Search Applicant Page: Editing Saved Search Mode](#).

## Running Saved Searches

<b>Field or Control</b>	<b>Description</b>
<b>Use Saved Search</b>	<p>To run a saved search, first select the search from this drop-down list box.</p> <p>The list of available saved searches includes only profile match searches. The list includes public searches as well as private advanced searches that you created.</p>

<b>Field or Control</b>	<b>Description</b>
<b>Run Saved Search</b>	Click to run the saved search that you selected.

### Search Criteria

<b>Field or Control</b>	<b>Description</b>
<b>Search Based On The</b>	<p>Select the type of profile that you want to match: <i>Applicant</i>, <i>Employee Job Opening</i>, or <i>Non Person</i>. Non person profiles are the profiles associated with job codes and position numbers.</p> <p><i>Employee</i> is available only if the Person Profile Integration field on the <a href="#">Recruiting Installation - General Page</a></p>
<b>With &lt;object type&gt; ID</b>	<p>Enter the unique ID for the object that you want to match.</p> <p>The label for this field depends on the type of object. For example, if you search based on a job opening, the label is With Job Opening ID.</p> <p>For security reasons, you cannot prompt for applicant IDs; instead, you must manually enter the ID.</p> <p>When selecting an employee ID, recruiting administrators can select any employee. Other users can select only their own employee ID and the employee IDs of their direct reports, if any.</p> <p>If the Enforce Search Save field on the <a href="#">Recruiting Installation – Jobs Page</a> is set to <i>Yes</i>, then users are forced to save their search criteria any time they perform a search where a job opening ID is specified. Additionally, after saving the criteria and performing the search, the system displays a message reminding the user to save the search results using the Save for Compliance button at the bottom of the page.</p>

<b>Field or Control</b>	<b>Description</b>
<b>And Find Similar</b>	<p>Select the type of profile that you are searching for: <i>Applicants, Employees, Job Openings, or Non Persons</i></p> <p>For example, if you are searching for employees that match a particular job opening, then select <i>Employee</i></p> <p>If you are matching a non-person profile, the only available options are <i>Job Opening</i> and <i>Non Person</i>.</p> <hr/> <p><b>Important!</b> When you search for job openings, only job openings with open postings are included in the search results.</p> <hr/>
<b>Search</b>	Click to perform the search.
<b>Save Search</b>	Click to save your search criteria.
<b>Clear</b>	Click to restore the default search criteria.

### Search Results: General

These fields appear in the search results grid regardless of the types of profiles that have been compared.

<b>Field or Control</b>	<b>Description</b>
<b>Select</b>	<p>Before clicking the Compare button, use this check box to select the rows to include in the comparison.</p> <p>If you searched for applicants, you also use this check box to select which applicants to include in a group action.</p>
<b>Score</b>	<p>Displays a score that represents how closely the application matches your search criteria.</p> <hr/> <p><b>Note:</b> Scores for a particular pair of profiles can vary depending on the search direction. A simplified example of this is if a job opening lists five competencies and the applicant has four of them. The job opening has 100% of the applicant's competencies, but the applicant has only 80% of the job opening's competencies, and the scores will reflect this.</p> <hr/>

### Search Results: Applicants

When you search for applicants, the search results grid shows the same information and supports the same actions as the search results grid for a keyword search or advanced search.

## Search Results: Employees and Job Openings

When you search for anything other than applicants, the search results provide basic identifying information about each object. For example, if you searched for jobs, the grid shows the job opening ID and posting title, and if you searched for employees, the grid shows the employee’s name and employee ID.

<i>Field or Control</i>	<i>Description</i>
 <b>Invite Application</b>	<p>If you searched for employees with profiles similar to a specific job opening, or for job openings that are similar to a specific employee ID, the search results grid includes the <b>Invite Application</b> column. Click the icon in this column to send the employee an email invitation to apply for the job opening. The text of the email comes from the <i>HRS_INVITE_APPLICATION</i> generic template. Only employees for whom you have email addresses can be invited to apply.</p> <p>Until the employee applies, there is no applicant record for the employee, and you cannot perform any recruiting actions related to the employee.</p>

## Group Actions and Compare Profiles

<i>Field or Control</i>	<i>Description</i>
<b>Select All</b> and <b>Deselect All</b>	Use these links to select or deselect grid rows to include when you perform a group action or compare profiles.
<b>Group Action</b>	<p>The Group Actions related action menu appears only if you searched for applicants. Click to display a menu of group actions that you can perform for the selected applicants. The list of available group actions is the same as the list of actions that are available from the <b>Actions</b> menu for a single row.</p> <hr/> <p><b>Note:</b> The number of rows that can be included in a group action can be limited using the Group Action Limit field on the <a href="#">Recruiting Installation – Applicants Page</a>. If a user attempts to perform a group action when too many rows are selected, the system displays a message informing the user of the limit and stating that only the allowed number of rows will be processed. If the user continues, the system processes the allowed number of rows, starting at the beginning of the list and following the grid sort order. Even if the user cancels, the system deselects all rows after the specified limit, and the user can review which rows will be processed before re-initiating the action with an allowable number of selected rows.</p> <hr/>



<i>Field or Control</i>	<i>Description</i>
<b>Compare</b>	Click to access the Compare Results page, where you can see detailed information about each content item in the source profile and you can see how well each selected profile matches each content item.

## Compare Results Page

Use the Compare Results page (HRS\_COMPARE\_RES) to review a detailed profile comparison.

The page always displays the profile that you were trying to match; you select rows from the search results to compare to that profile.

Navigation:

Click the **Compare** button on the Search Applicants page: Profile Match tab.

---

**Note:** When you access this page after selecting only one row from the search results, the page title is Match Result.

---

This example illustrates the Compare Results page.

### Find Applicants - Profile Match

## Compare Results

Select One or 'View All Sections' to compare the content item details between the profile you selected and the matching applicant, job opening, employee or non-person profile results that were marked previously .

\*View Content Section View All Sections ▼

■ No Match ▼ Partial Match ● Complete Match

Compare Results		
Search Criteria: - Administrative Assistant	John Pak: 77%	Stanley Lowe: 62%
<b>Competencies</b> <i>Ability to prioritize tasks :</i> Interest Level: 2-No Preference Proficiency: 3-Good	<b>Competencies</b> ● 100% 2-No Preference 3-Good	<b>Competencies</b> ● 100% 2-No Preference 3-Good
<i>Organize people and goal tasks :</i> Interest Level: 2-No Preference Proficiency: 3-Good	● 100% 2-No Preference 3-Good	● 100% 2-No Preference 3-Good
<i>Resource Planning :</i> Interest Level: 2-No Preference Proficiency: 3-Good	● 100% 2-No Preference 3-Good	● 100% 2-No Preference 3-Good
<i>Persuasive :</i> Proficiency: 3-Good	● 100% 3-Good	● 100% 3-Good
<i>Business Planning :</i> Proficiency: 3-Good	● 100% 3-Good	■ 0% --
<i>Achievement Orientation :</i> Proficiency: 3-Good	● 100% 3-Good	■ 0% --
<i>Practices ethical behavior :</i> Proficiency: 3-Good	● 100% 3-Good	■ 0% --
<b>Language Skills</b> <i>English :</i> Native Language: No Able To Translate: No Able To Teach: No	<b>Language Skills</b> ■ 0% -- -- --	<b>Language Skills</b> ▼ 66% Yes No No
<i>Spanish :</i> Native Language: No Able To Translate: No Able To Teach: No	■ 0% -- -- --	▼ 99% No No No

[Return to Previous page](#)

The first column (or, in accessible mode, the first grid) displays the content sections and content items in the source profile (the one that the search results were compared to).

The remaining columns (or, in accessible mode, the second grid) show the corresponding data in the profiles that you selected for comparison. For each profile, an overall score indicates how closely the data matches the source profile. Additional scores represent the degree to which individual content items match the corresponding item in the source profile.. For information on how scores are calculated, see “(Classic) Searching and Comparing Profiles” (PeopleSoft Human Resources Manage Profiles). Note that the Profile Match search disregards settings marking any particular content item as required and sets the importance of every content item to *Average*.

<b>Field or Control</b>	<b>Description</b>
View Content Section	Select <i>View All Sections</i> to list all the sections in the profiles, or select a section to view the information for one content section. The default is View All Sections.

## Browse Applicants Page

Use the Browse Applicants page (HRS\_APPLICANT\_SRCH) to use faceted searches to set filtering criteria as you browse your applicants.

**Note:** This page shows only applicants who have applied for job openings (in any status) that are associated with the current user. The user can be associated with the job opening either as the creator or as a member of the hiring team. Job openings that the user can access due to department tree security are not included.

Navigation:

### Recruiting > Browse Applicants

This example illustrates the Browse Applicants page.

The screenshot shows the 'Browse Applicants' interface. At the top, there are navigation links: Return, Recruiting Home, Browse Job Openings, Search Applicants, and Create Applicant. A search bar is present with the text 'Search applicants'. Below the search bar, filter criteria are shown: '010 Active', 'Employee', and 'United States', with a 'Clear All Filters' link. A 'Filter by' section on the left lists categories like Applicant Type (Employee: 22), Status (010 Active: 22), Location (No Value: 8, California: 6, District of Columbia: 2, Kansas: 2, New York: 2), and Applied In (2004: 12, 2005: 5, 2008: 1, 2009: 1, 2011: 1). The main area displays a table of 22 matches found, with columns for Applicant ID, Name, Applicant Type, Status, Preferred Contact, Phone, Email, Jobs Applied, Last Job Applied To, Application, and Print. The table lists several applicants, including John Patterson, Gowri Shankar, CaiLee Calvert, Geoff Piper, Gabe Kaminsky, John Johnson, Craig Carson, and Adrienne Turner.

## Understanding the Browse Applicants Page

The Browse Applicants page displays a grid listing the applicants that meet your criteria. You can specify criteria two ways

- Perform a keyword search using the search field that appears above the grid.
- Use the **Filter By** area to the left of the grid to choose filtering criteria.

The Filter By fields provides filtering capability based on data such as the applicant type or status. Each field displays a set of links listing available values. The number next to each value indicates how many applicants in the current list have that value. Clicking a link activates the filter, updates the applicants grid, and updates the Filter By area to show only values that exist in the current set of applicants.

For example, suppose the applicants grid initially lists 100 applicants. In the Filter By area, the Applicant Type filter shows that there are 80 external applicants and 20 employees. If you click the Employee link, the applicants grid lists only those 20 internal applicants, and the External Applicant link under the Applicant Type filter disappears because it is no longer represented in the current set applicants. At the same time, the values for other filter fields change. Perhaps the original 100 applicants included applicants from seven different locations, but after you click the Employees link, the remaining 20 applicants represent only three locations. In this situation, applying the department filter shortens the list of filtering values for the Location filter.

As you click the filtering links, each filter criteria appears directly above the Applicants grid. To remove a filter, click the adjacent x (the Remove Filter icon).

### Toolbar

<i>Field or Control</i>	<i>Description</i>
<b>Return</b>	Click to return the page from which you accessed this page.
<b>Recruiting Home</b>	Click to access the <a href="#">Recruiting Home Page</a> .
<b>Browse Job Openings</b>	Click to access the <a href="#">Browse Job Openings Page</a> where you can search for job openings using a combination of keyword searching and faceted filtering.
<b>Search Applicants</b>	Click to display the <a href="#">Search Applicants Page</a> , which offers additional applicant search options.
<b>Create Applicant</b>	Click to access the <a href="#">Create Applicant Page</a> , where you start the process of creating a new applicant record.
<b>Personalize</b>	Click to change the content and layout of the toolbar.

### Keyword Search

<i>Field or Control</i>	<i>Description</i>
 <b>Search</b>	<p>Use the text field under the toolbar to enter search terms, then click the Search icon to perform the search. The system looks for the keyword in the applicant record and in the application details, including the applicant’s resume.</p> <p>Keyword search criteria is not listed with the currently active filters (in the area just below the keyword search field), so there is no corresponding Remove Filter icon. Instead, you clear the search directly in the text field.</p>

## Active Filters

<i>Field or Control</i>	<i>Description</i>
 <b>Remove Filter</b>	Above the Applicants grid, the page displays your currently active filters. Click the Remove Filter icon next to an active filter to remove the filter.
<b>Clear All Filters</b>	Click to remove all field-based filters. Clicking this link does not clear the keyword search filtering.



## Filter By

<i>Field or Control</i>	<i>Description</i>
<b>Applicant Type</b>	Use this field to filter based on the applicant type: External Applicant, Employee, or Non-Employee.
<b>Status</b>	Use this field to filter based on the applicant status.
<b>Location</b>	This field offers hierarchical filtering based first on the applicant's country, then state or province, then city.
<b>Applied In</b>	This field offers hierarchical filtering based first on the year that the application was created and then, after you select a year, based on the month that the application was created.

## Applicants

This grid displays a list of applicants that meet your current browsing criteria.

<i>Field or Control</i>	<i>Description</i>
<b>&lt;X&gt; matches found. Only the first 300 results can be displayed.</b>	<p>The search and filtering capabilities of the Browse Applicants page are powered by the PeopleTools Search Framework and its underlying search engine. Therefore, the Applicants grid on this page observes any system-wide setting that sets the maximum number of search results. This page has an additional restriction limiting the grid to 300 applicants, even if the system-wide maximum is higher.</p> <p>If more than 300 applicants meet the current search criteria, this message alerts the user to the fact that there are additional applicants who are not displayed.</p>

<b>Field or Control</b>	<b>Description</b>
<b>Name</b>	Click the applicant name to access the <a href="#">Manage Applicant Page</a> .
 <b>Email</b>	<p>The Email icon appears if the applicant record includes a primary email address. The system displays the actual email address as mouseover text for the icon.</p> <p>Click the icon to access the <a href="#">Send Correspondence Page</a> to send email (or a letter) to the applicant. If a user does not have authorization for the Send Correspondence component, the user's default email client is opened instead.</p>
<b>Jobs Applied</b>	<p>Displays the number of jobs for which the applicant has applications.</p> <p>All job openings are included, even if they are closed or if the user does not have security access to the opening. If the applicant applied more than once to the same job opening, that opening is counted only once.</p> <p>Applications not linked to a job opening are not included in the count, nor are unsubmitted (draft) applications</p>
<b>Last Job Applied To</b>	Displays the job opening ID and title for the applicant's most recent application. Click the link to access the <a href="#">Manage Job Opening Page</a> .
 <b>Application</b>	Click to access the <a href="#">Manage Application Page</a> , where you can review and manage activity related to a single applicant for a single job opening.
 <b>Print</b>	Click to access the <a href="#">Application Report Options Page</a> , where you can choose report parameters and then generate an application details report.

---

## Working With Saved Searches

This topic provides an overview of saved searches and discusses how to work with saved searches.

## Pages Used to Work With Saved Searches

<i>Page Name</i>	<i>Definition Name</i>	<i>Usage</i>
<a href="#">Save Search Page</a>	HRS_REC_SAV_SCH	Save applicant search criteria.
<a href="#">Search Applicant Page: Editing Saved Search Mode</a>	HRS_REC_SCHAPP	Edit a saved search.
<a href="#">Save Compliance Search Page</a>	HRS_REC_SAV_RSL	Save search results for auditing and statutory reporting purposes.
<a href="#">Saved Searches Page</a>	HRS_REC_SEARCHES	Review saved searches, and either run them or review the results, depending whether the criteria or results were saved.
<a href="#">Automatch Results Page</a> <a href="#">Compliance Results Page</a>	HRS_REC_SCHRSLTS	View saved search results.
<a href="#">Run Automatch Search Page</a>	HRS_RUN_AMH	Run the Run Automatch Search (HRS_AM) process to search for applicants that meet the criteria in automatch searches.

## Understanding Saved Searches

This overview describes options for saving searches and search results.

### Searches Where Saving is Enabled

These three search options enable you to save searches:

- [Search Applicants Page: Keyword Search Tab](#)
- [Search Applicants Page: Advanced Search Tab](#)
- [Search Applicants Page: Profile Match Tab](#)

### Types of Saved Searches

The following table summarizes the three types of saved searches:

<b>Saved Search Type</b>	<b>Description</b>	<b>Supported Searches</b>
Criteria	Save criteria so that you can re-run the search on demand.	<ul style="list-style-type: none"> <li>• Keyword search</li> <li>• Advanced search</li> <li>• Profile Match search</li> </ul>
Automatch	Save criteria so that an automated process can perform the search on a regular schedule and send you any new search results each time it runs.	<ul style="list-style-type: none"> <li>• Keyword search</li> <li>• Advanced search</li> </ul>
Compliance	Save search results as a static list.	<ul style="list-style-type: none"> <li>• Keyword search</li> <li>• Advanced search</li> <li>• Profile Match search</li> </ul>

### Criteria Searches

To save search criteria, use the Save Search button that appears in the same group box as the search criteria. The system saves the criteria under a name that you assign. You can select and run a saved search from the page where you would normally run the search or from the Saved Searches page.

The saved search appears on the Saved Searches page with the results type *Criteria*

On the Recruiting Installation – Jobs Page, you can make it mandatory to save search criteria when a specific job opening is part of the criteria. This option applies to the Advanced search and the Profile Match search (the two searches where users can enter a job opening ID in the search criteria). When this option is active, the system forces the save by displaying the Save Search page after the user initiates the search but before the search results appear. The user cannot continue to the results without saving the criteria, even if there are no search results. The user can, however, cancel to return to the search page without executing the search.

### Automatch Searches

When you save search criteria, you can mark the saved search as an automatch search to be run in batch at regularly scheduled times. The Run Automatch Search (HRS\_AM) process performs the searches and, if the search criteria includes a specific job opening, the process sends the search results to the recruiter who is associated with the job opening. The system keeps track of which applicants have already been sent to the recruiter, so each time the automatch search runs, it sends only the applicants that have not been previously sent.

If the automatch search is not associated with a job opening, no notifications are sent. However, users can go to the Saved Searches page to access the search results.

When you save an automatch search, you can specify a specific end date after which the search becomes inactive. Or, if the search criteria includes a specific job opening, you can specify that the search becomes inactive either when the job opening is closed or on the last posting close date.



The saved search appears on the Saved Searches page with the results type *Automatch*.

---

**Note:** This option is not available for profile match searches.

---

## Results Saved for Compliance

For auditing and statutory reporting purposes, you can save the results of specific searches. To save search results, use the Save for Compliance button. This button appears below the search results grid for the three PeopleTools Search Framework searches (Keyword searches, Advanced searches, and Profile Match searches). If the Recruiting Installation option to enforce saved searches is active, then after a forced save, the search page displays a message reminding the user to consider saving the results.

The saved search appears on the Saved Searches page with the results type *Compliance*.

Once you save a set of search results, you cannot delete it.

---

**Note:** Although the original search results grid can include separate rows for each application that meets the search criteria, the saved results show only one row per applicant per application date. That is, if an applicant submits multiple applications on the same date, the original search results show a row for each application, but the saved results show one row for the date.

---

## Public and Private Searches

Saved searches can be designated as either public or private. Although anyone can run a public search, only administrators and the creator of the search can update or delete the search criteria.

## Persistent Association With A Job Opening

The following saved searches are associated with specific job openings:

- Automatch searches where the search criteria includes a specific job opening.
- Compliance searches where the search criteria includes a specific job opening.
- Criteria searches that are created when the [Recruiting Installation – Jobs Page](#) is configured to force users to save search criteria that includes a specific job opening.

The Saved Searches page shows which job opening, if any, are associated with each saved search

The Job Opening page also lists the saved automatch and compliance searches that are associated with the job opening. The list appears in two locations:

- In the Saved Compliance & Automatch Searches grid on the [Manage Job Opening Page: Activity & Attachments Tab](#)
- In the Saved Compliance & Automatches Searches grid on the [Manage Job Opening Page: Applicant Search Tab](#)

## Save Search Page

Use the Save Search page (HRS\_REC\_SAV\_SCH) to save applicant search criteria.

Navigation:

**Recruiting > Search Applicants**

On the Search Applicants page, enter criteria on any tab other than the Quick Search tab, then click the **Save Search** button.

This example illustrates the Save Search page.

<b>Field or Control</b>	<b>Description</b>
<b>Search Name</b>	Enter a name for the saved search. This name identifies this saved search on the Saved Searches page.
<b>Job Opening ID</b>	If the search criteria that you are saving included a job opening; the field displays the job opening ID. You cannot change this value. If a job opening ID appears, the saved search will retain an association with that job opening. The association ensures that the search is listed on the Job Opening page under both the Activity & Attachments tab and the Applicant Search tab.
<b>Access</b>	Select the access type for this search. Options are: <ul style="list-style-type: none"> <li>• <i>Private</i>: Only the creator of the search can access, modify, or delete this search.</li> <li>• <i>Public</i>: Anyone can access this search, but only the creator or an administrator can modify it or delete it.</li> </ul>
<b>Setup as Auto match</b>	Select this check box to create an automatch search that will be processed by the Run Automatch Search process.

**Automatch Options**

This group box is visible if the **Setup as Automatch** check box is selected. Use the fields in this group box to control how long the automatch search remains active.

<b>Field or Control</b>	<b>Description</b>
<b>End Search Agent On and End Date</b>	<p>If the automatch search includes a job opening, select from these options: <i>End on Max Posting Close Date</i>, <i>End on Job Opening Close Date</i>, or <i>End on Specified Date</i>.</p> <p>If the automatch search does not include a job opening, the system selects <i>End on Specified Date</i> and the field becomes read-only.</p> <p>If the <b>End Search Agent On</b> field is <i>End on Specified Date</i>, then enter the date on which the automatch search expires.</p>

## Search Applicant Page: Editing Saved Search Mode

Use the Search Applicant page to edit a saved search.

Navigation:

Fields for editing a saved search appear when you access the Search Applicant page any of the following ways:

- Click a search name on the [Saved Searches Page](#)
- Save a search on the [Search Applicants Page](#).
- Perform a saved search from either the Search Applicants page or the Saved Searches page..

This example illustrates the additional elements that appear on the Search Applicants page: Keyword tab when you edit a saved keyword search. The same additional elements appear on the Advanced Search tab when you edit an advanced search.

### Saved Search

This group box shows the same fields that appear on the [Save Search Page](#) . You can edit any of this information.

## Buttons

<i>Field or Control</i>	<i>Description</i>
<b>Run Search</b>	Click to run the saved search. This button replaces the <b>Search</b> button that normally appears on the page.
<b>Save Changes</b>	Click to save changes to your saved search. Changes that are saved include: <ul style="list-style-type: none"> <li>• Changes that you made to the saved search data (the name, status, access, and automatch settings)</li> <li>• Changes that you made to the search criteria.</li> </ul>
<b>Delete Search</b>	Click to delete the saved search.  You can also delete saved searches on the <a href="#">Saved Searches Page</a> .

## Save Compliance Search Page

Use the Save Compliance Search page (HRS\_REC\_SAV\_RSL) to save search results for auditing and statutory reporting purposes.

Navigation:

**Recruiting > Search Applicants**

On the Search Applicants page, perform a search on any tab except Quick Search , then click the **Save for Compliance** button that appears with the search results.

This example illustrates the Save Compliance Search page.

The screenshot shows a dialog box titled "Save Compliance Search". It contains the following elements:

- A text input field labeled "\*Results Set Name".
- A label "Job Opening ID" followed by the value "503708".
- A dropdown menu labeled "Access" with "Public" selected.
- Three buttons at the bottom: "OK", "Cancel", and "Refresh".

<b>Field or Control</b>	<b>Description</b>
<b>Results Set Name</b>	Enter a name for the saved search results. This name identifies this saved search on the Saved Searches page.
<b>&lt;Profile ID&gt;</b>	<p>If the search criteria identified a job opening, employee ID, or non-person profile, this read-only field displays the selected value. The field label changed depending on the type of profile shown.</p> <p>If the search criteria did not identify a job opening, employee ID, or non-person profile, this field is hidden.</p> <p>If you save a search that is associated with a job opening, the saved search will retain an association with that job opening. The association ensures that the search is listed on the Job Opening page under both the Activity &amp; Attachments tab and the Applicant Search tab.</p>
<b>Access</b>	<p>Select the access type for this search. Options are:</p> <ul style="list-style-type: none"> <li><i>Private</i>: Only the creator of the search can access this search.</li> <li><i>Public</i>: Anyone can access this search.</li> </ul>

## Saved Searches Page

Use the Saved Searches page (HRS\_REC\_SEARCHES) to review saved searches, and either run them or review the results, depending whether the criteria or results were saved.

Navigation:

**Recruiting > Saved Searches**

This example illustrates the Saved Searches page.

Search Name	Results Type	Search Type	Last Updated	Job Opening	Access	Status	Run Search
503708 - ARBITRATION	Compliance	Advanced	2013-01-29	Bring Your Arbitration Experience to Labor Relations	Public	Active	View Results
ADMIN OPPORTUNITY	Criteria	Advanced	2009-08-09	None	Public	Active	Search
EXAMP 2-EMPS NOT APP	Criteria	Profile Match	2009-08-09	None	Public	Active	Search
EXAMPLE SEARCHMATCH	Criteria	Profile Match	2009-08-09	None	Public	Active	Search
HRIS IN OAKLAND	Criteria	Advanced	2004-09-29	None	Public	Active	Search
LABOR RELATIONS	Automatch	Advanced	2013-01-29	Bring Your Arbitration Experience to Labor Relations	Private	Active	View Results
NURSES	Criteria	Keyword	2013-01-29	None	Public	Active	Search
PHYSICISTS	Automatch	Keyword	2013-01-29	None	Public	Active	View Results
SEARCH J.O. 500002	Criteria	Advanced	2009-08-09	None	Public	Active	Search
TECH SF	Criteria	Advanced	2004-09-29	None	Public	Active	Search
CALIFORNIA SEARCH	Criteria	Advanced	2012-09-07	None	Public	Active	Search
COLORADO SEARCH	Criteria	Advanced	2012-06-21	None	Public	Active	Search

## Toolbar

<i>Field or Control</i>	<i>Description</i>
<b>Recruiting Home</b>	Click to access the <a href="#">Recruiting Home Page</a> .
<b>Search Applicants</b>	Click to access the <a href="#">Search Applicants Page</a> .

## Saved Searches and Automatches

This grid lists public saved searches as well as private saved searches that you created. You cannot see other users' private saved searches.

<i>Field or Control</i>	<i>Description</i>
<b>Search Name</b>	<p>Displays the name of the saved search. If you are the owner or administrator of a saved criteria search or automatch search (other than a Profile Match search), the name is a link that you click to access the Search Applicant page in a mode where you can edit the search criteria and save your changes.</p> <hr/> <p><b>Note:</b> When you access the Search Applicants page from the Saved Searches page, the fields for defining the saved search appear on the Search Applicants page. Use these fields, and the additional Save Changes and Delete Search buttons, to modify or delete your saved search.</p> <hr/>
<b>Results Type</b>	Displays <i>Criteria</i> , <i>Automatch</i> , or <i>Compliance</i> to indicate the type of saved search.
<b>Search Type</b>	Displays <i>Keyword Advanced</i> , or <i>Profile Match</i> to indicate which mode the Search Applicants page was in when you entered the search criteria or performed the search.
<b>Last Updated</b>	Displays the date that the search was most recently saved.
<b>Job Opening</b>	<p>For searches that are associated with a specific job opening, this field identifies the job opening and provides a link to the Job Opening page.</p> <p>For other searches, this field displays <i>None</i>.</p>
<b>Access</b>	Displays <i>Public</i> or <i>Private</i> to indicate who has access to the search. The only private searches that appear in the grid are the ones that the current user created.

<b>Field or Control</b>	<b>Description</b>
<b>Status</b>	Displays <i>Active</i> or <i>Inactive</i> . To change a search’s status, click the search name to edit it.
<b>Run Search</b>	<p>For criteria searches, a Search button appears. Click this button to run the search and view results on the Search Applicants page.</p> <p>For automatch searches, a View Results button appears. Click this button to view the results from the last time the search was processed. If the search has not yet been processed, no results exist.</p> <p>For compliance searches, a View Results button appears. Click this button to view the saved results.</p>

## Automatch Results Page

Use the Automatch Results page (HRS\_REC\_SCHRSULTS) to view the results of an automatch saved search.

Navigation:

Click the **View Results** button for an automatch search on the Saved Search page.

This example illustrates the Automatch Results page.

Select	Score	Applicant	Applicant ID	Type	Status	Employee Referral	Application Detail	Resume	Phone	Email Address	Date Applied	Jobs Applied	Actions
<input type="checkbox"/>		Jan Bradley	2	External Applicant	010 Active				510/562-2333	HCMGENUser1@ap6023fems.us.oracle.com	08/30/2001	4	Actions
<input type="checkbox"/>		Tracy Maguire	14	External Applicant	010 Active						08/25/2003	1	Actions
<input type="checkbox"/>		Juana Gonzalez	21	External Applicant	010 Active						03/10/2001	1	Actions
<input type="checkbox"/>		Jody McGinniss	26	External Applicant	010 Active						08/24/2001	1	Actions
<input type="checkbox"/>		Ernesto Villareal	47	Employee	010 Active						04/20/2001	2	Actions
<input type="checkbox"/>		Carmichael Espinosa	66	External Applicant	010 Active						10/02/1980	1	Actions
<input type="checkbox"/>		Sarah Burkitt	70	External Applicant	010 Active						04/17/2001	2	Actions

<b>Field or Control</b>	<b>Description</b>
<b>Search Criteria</b>	Expand this section to view the criteria for the search.
<b>Save for Compliance</b>	Click this button to save the results for auditing and statutory reporting purposes.

<b>Field or Control</b>	<b>Description</b>
<b>Search Results</b>	Displays the results from the last time that the Run Automatch Search (HRS_AM) Application Engine process ran this search. Each time this process runs, the new search results replace any previous search results.

## Compliance Results Page

Use the Compliant Results page (HRS\_REC\_SCHRSULTS) to view search results that were saved for Compliance.

Navigation:

Click the **View Results** button for a compliance search on the Saved Search page.

This example illustrates the Compliance Results page.

Compliance Results											
<a href="#">Return</a>   <a href="#">Recruiting Home</a>											
<a href="#">Search Criteria</a>											
300 Results Found <span style="float: right;"> <a href="#">First</a> <a href="#">Previous</a> <a href="#">Next</a> <a href="#">Last in List</a> </span>											
Created 02/19/2013 7:40AM PS											
Score	Applicant	Applicant ID	Type	Status	Application Detail	Resume	Former Employee	Phone	Email Address	Date Applied	Jobs Applied
2	Jan Bradley	External Applicant 010	Active					510/562-2333	HCMGENUser1@ap6023fems.us.oracle.com	08/30/2001	4
14	Tracy Maguire	External Applicant 010	Active							08/25/2003	1
21	Juana Gonzalez	External Applicant 010	Active							03/10/2001	1
26	Jody McGinniss	External Applicant 010	Active							08/24/2001	1
47	Ernesto Villareal	Employee	010 Active							04/20/2001	2
66	Carmichael Espinosa	External Applicant 010	Active							10/02/1980	1
70	Sarah Burkitt	External Applicant 010	Active							04/17/2001	2
82	Faith Fazio	Employee	010 Active							08/29/2003	4
88	Jen Ramsay	Employee	010 Active							08/26/2003	1
101	Jhon Davis	Employee	010 Active							01/01/2000	1

<b>Field or Control</b>	<b>Description</b>
<b>Search Criteria</b>	Expand this section to view the criteria for the search.
<b>Created</b>	Displays the date and time that the results were saved, and the user ID of the person who saved the results.
<b>Search Results</b>	Displays the saved search results.

## Run Automatch Search Page

Use the Run Automatch Search page (HRS\_RUN\_AMH) to run the Run Automatch Search (HRS\_AM) Application Engine process. This process searches for applicants that meet the criteria in automatch searches.



Navigation:

**Recruiting > Administration > Run Automatch Search**

This example illustrates the Run Automatch Search page.

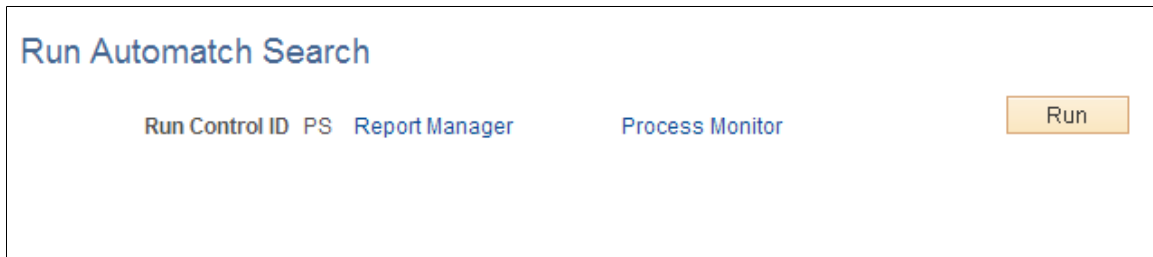

The Run Automatch Search (HRS\_AM) process searches the applicant database for applicants that match the criteria in all saved automatch searches.

When the system finds an applicant that matches the criteria, a workflow sends emails to the recruiters responsible for the requisitions. Recruiters can view the results of the Automatch search and then link the applicants to the job opening.

See [Understanding Saved Searches](#).

---

## Managing Applicants

This topic provides an overview of the Manage Applicant page and discusses how to use this page as a central hub for applicant tracking.

### Pages Used to Manage Applicants

<i>Page Name</i>	<i>Definition Name</i>	<i>Usage</i>
<a href="#">Manage Applicant Page</a>	HRS_MANAGE_APP	Review applicant recruitment data and perform various applicant-related tasks.

<b>Page Name</b>	<b>Definition Name</b>	<b>Usage</b>
Manage Applicant Page: Applicant Activity Tab	HRS_MANAGE_APP	<p>Manage applicant activity and perform actions on an applicant's current job applications. This tab includes four subsections:</p> <ul style="list-style-type: none"> <li>• <a href="#">Manage Applicant page: Applicant Activity Tab: Current Status Section</a></li> <li>• <a href="#">Manage Applicant page: Applicant Activity Tab: Interview Schedule/Evaluation Section</a></li> <li>• <a href="#">Manage Applicant Page: Applicant Activity Tab: Expenses Section</a></li> <li>• <a href="#">Manage Applicant Page: Applicant Activity Tab: History Section</a></li> </ul>
<a href="#">Applicant Resume Page</a>	HRS_APP_RESUME	View a resume that was copied into the resume text field (rather than being uploaded as an attachment).
<a href="#">Expenses Page</a>	HRS_APP_EXP_SP	Enter details about an applicant-related expense.
<a href="#">Manage Applicant Page: Notes Tab</a>	HRS_MANAGE_APP	Review and create notes for applicants.
<a href="#">Manage Applicant page: Applicant Data Tab</a>	HRS_MANAGE_APP	View or modify an applicant's personal information, references, and eligibility & Identity information.
<a href="#">Manage Applicant page: Interested Parties Tab</a>	HRS_MANAGE_APP	Identify interested parties so that they can be easily copied on email correspondence.
Proxy Details Page	HRS_APP_PROXY_SBP	<p>View the name, phone number, and email address of the contact for the recruitment service that is acting as the applicant's proxy.</p> <p>The toolbar button for accessing this page is visible only if at least one of the applicant's applications has a vendor recruitment source that has a proxy.</p>

## Understanding The Manage Applicant Page

The Manage Applicant page provides a central location for reviewing applicant data and performing applicant-related tasks. It is divided into four tabs, as described in the following table:

<b>Tab</b>	<b>Description</b>
Applicant Activity	<p>Use this tab to manage recruiting activities for the applicant. It is divided into four subsections:</p> <ul style="list-style-type: none"> <li>• <i>Current Status</i> shows summary information about the applicant's dispositions for all open job openings (or applications without job openings). It also provides access to detailed application data and to the various actions that you use to manage the recruiting process.</li> <li>• <i>Interview Evaluation/Summary</i> shows summary information about interviews and interview evaluations. It also provides access to the pages you use to manage the interviews and evaluations.</li> <li>• <i>Expenses</i> enables you to manage expense data.</li> <li>• <i>History</i> shows the applicant's disposition history for all associated job openings.</li> </ul>
Notes	<p>This tab displays notes related to the applicant. Notes can be system-generated or manually created. Buttons on this tab enable you to add notes and view note details.</p>
Applicant Data	<p>This tab provides access to the same applicant data that you enter on the Create Applicant page: personal information, references, and eligibility &amp; identity information.</p>
Interested Parties	<p>This tab enables you to enter email addresses for interested parties (including interested parties outside of the system) so that they can be easily copied on email correspondence.</p>

This diagram illustrates the hierarchical structure of the tabs and sections on the Manage Applicant page.

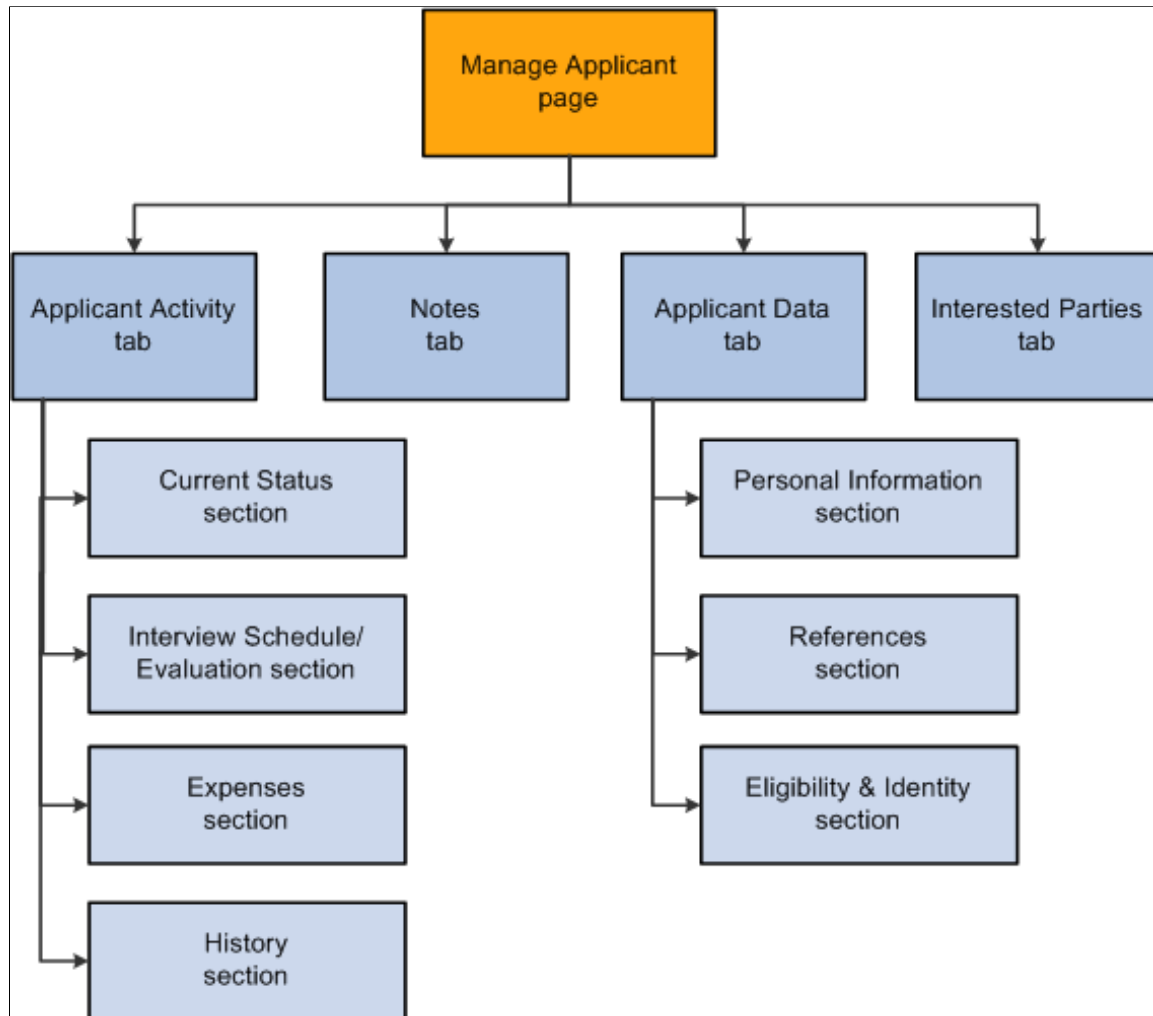

## Manage Applicant Page

Use the Manage Applicant page (HRS\_MANAGE\_APP) to review applicant recruitment data and perform various applicant related tasks.

Navigation:

- **Recruiting > Search Applicants**

Click an applicant name link in the **Search Results** grid on the Search Applicants page.

- Click an applicant name on any page or pagelet where the applicant name is a link, including the My Applicants pagelet, the Search Applications page, the Manage Application page, and the Manage Job Openings page.

This example illustrates the Manage Applicant page.

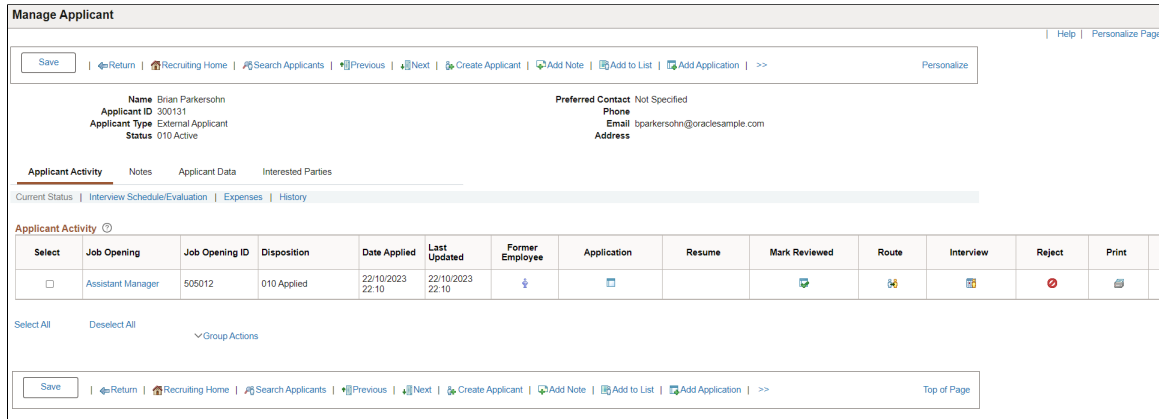

### Toolbar

<b>Field or Control</b>	<b>Description</b>
<b>Save</b>	Click this button to save any changes you make on the Applicant Data tab or the Interested Parties tab.
<b>Return</b>	Click this button to return the page from which you accessed the Manage Applicant page.
<b>Recruiting Home</b>	Click this button to access the <a href="#">Recruiting Home Page</a> .
<b>Search Applicants</b>	Click this button this button to access the <a href="#">Search Applicants Page</a> .
<b>Previous and Next</b>	These buttons appear if you accessed the Manage Applicant page from a grid that listed multiple applicants. Use the buttons to navigate between applicants.
<b>Create Applicant</b>	Click this button to create a new applicant on the <a href="#">Create Applicant Page</a> .
<b>Add Note</b>	Click this button to create a new applicant note on the <a href="#">Applicant Notes Page</a> .
<b>Add to List</b>	Click this button to access the <a href="#">Add to Applicant List Page</a> where you choose an applicant list to which the applicant is added.

<b>Field or Control</b>	<b>Description</b>
<b>Add Application</b>	Click to open a new application on the <a href="#">Application Details Page</a>
<b>Change Status</b>	Click to open the <a href="#">Change Applicant Status Page</a> where you can change the overall status of the applicant (not the applicant's disposition for any particular job opening).
<b>Forward Applicant</b>	Click this button to access the <a href="#">Forward Applicant Page</a> where you can send an email with applicant information.
<b>Link to Job</b>	Click this button to open the <a href="#">Link Applicant to Job Opening Page</a> where you can choose additional job opening for the applicant.
<b>Merge Applicants</b>	Click this button to open the <a href="#">Merge Applicant Page</a> where you can identify and merge duplicate applicant records.
<b>Personalize</b>	Click this button to change the content and layout of the toolbar.
<b>Proxy Details</b>	Click this button to display the Proxy Details page. This button appears only if at least one of the applicant's applications has a vendor recruitment source that has a proxy.

## Header Data

<b>Field or Control</b>	<b>Description</b>
<b>Name and Applicant ID</b>	These fields display identifying information about the applicant.
<b>Applicant Type</b>	Displays whether the applicant is an <i>External Applicant</i> , <i>Employee</i> , or a <i>Non-Employee</i> (a person of interest).
<b>Status</b>	Displays the overall applicant status. This is not the disposition with regards to any particular job opening, it is a more general status such as <i>Active</i> or <i>Inactive</i> .
<b>Preferred Contact</b>	Displays the applicant's preferred contact method.

<i>Field or Control</i>	<i>Description</i>
<b>Phone, Email, and Address</b>	These fields display the applicant's contact information.

## Tabs

<i>Field or Control</i>	<i>Description</i>
<b>Applicant Activity</b>	Use the <a href="#">Manage Applicant page: Applicant Activity Tab: Current Status Section</a> to review applicant dispositions and to perform recruiting actions.  Use the other sections on this tab to manage interviews and expenses and to review disposition history.
<b>Notes</b>	Use the <a href="#">Manage Applicant Page: Notes Tab</a> to manage applicant-related notes.
<b>Applicant Data</b>	Use the <a href="#">Manage Applicant page: Applicant Data Tab</a> to manage the applicant's personal information, references, and eligibility & identity information.
<b>Interested Parties</b>	Use the <a href="#">Manage Applicant page: Interested Parties Tab</a> to manage the list of interested parties who can be copied on applicant correspondence.

## Manage Applicant page: Applicant Activity Tab: Current Status Section

Use the Manage Applicant page: Applicant Activity tab: Current Status section (HRS\_MANAGE\_APP) to review applicant recruitment data and perform various applicant related tasks.

Navigation:

- **Recruiting > Search Applicants**

Click an applicant name link in the **Search Results** grid on the Search Applicants page.

- Click an applicant name on any page or pagelet where the applicant name is a link, including the My Applicants pagelet, the Search Applications page, the Manage Application page, and the Manage Job Openings page.

This example illustrates the Manage Applicant page: Applicant Activity tab: Current Status section.

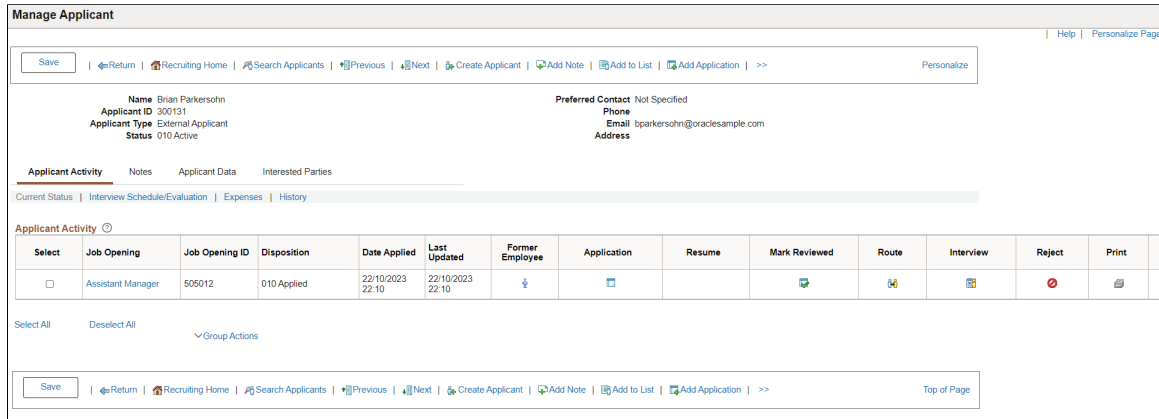

### Flexible Processing and Applicant Actions

A job opening’s flexible recruiting process (if any) can prevent users from performing certain recruiting actions that would otherwise be available from this page. The availability of the action depends on the user’s role and on the applicant’s current disposition.

These actions can be made unavailable: Reject Applicant, Route Applicant, Manage Interviews, Created Interview Evaluation, Prepare Job Offer, Accept Offer, Reject Offer, Pre-Employment Check, Prepare for Hire, Withdraw from Hire, and Manage Applicant Contracts.

Additionally, the Edit Disposition action is hidden if the flexible recruiting process does not provide the user with any valid disposition transitions.

The system hides the route, interview, and reject icons for job openings where those actions are not available. If the actions are not available for any job openings, the entire column is hidden.

The Other Actions menu also hides any unavailable actions.



The Group Actions menu does not hide actions, but the system only performs the action for job openings where the action is permitted.





### Applicant Activity

This grid lists an applicant’s open job openings. To view information about closed job opening, click the History link.

<b>Field or Control</b>	<b>Description</b>
<b>Select</b>	Before performing a group action, use this check box to select the job opening to which the group action applies.



<b>Field or Control</b>	<b>Description</b>
<b>Job Opening and Job Opening ID</b>	<p>These fields identify a job opening (or an application without a job opening) to which the applicant is linked. Click the job opening title to access the Manage Job Opening page for that job opening.</p> <p>If the user does not have security access to the job opening, the job opening link is disabled, as are any recruiting actions for that job. However, the Other Actions menu still provides access to applicant-related actions that do not rely on the context of the job opening.</p>
<b>Disposition</b>	<p>An applicant's disposition is the applicant's status with regards to a particular job opening. The values are the statuses that have been defined for the Recruitment Summary status area. These statuses track the progress of an applicant through the recruiting process.</p>
<b>Date Applied</b>	Displays the date when the application was submitted.
<b>Last Updated</b>	Displays the date when the application status was updated.
 <b>Former Employee</b>	<p>The Former Employee icon appears if the applicant identifies himself as a former employee when applying for the job.</p> <p>If none of the applicants in the grid are former employees, then this column is hidden.</p>
 <b>Application</b>	Click to access the <a href="#">Manage Application Page</a> , where you can review and manage activity related to a single applicant for a single job opening.
 <b>Resume</b>	<p>Click to open a new window that displays the applicant's resume. The window contents depend on the resume format:</p> <ul style="list-style-type: none"> <li>• If the resume is in an attached file, the file opens in the new window.</li> <li>• If the resume was entered into the <b>Resume Text</b> field in the application, the new window displays the Applicant Resume page.</li> </ul> <p>If the application that is linked to this job opening doesn't include a resume, then this column is blank.</p>

<b>Field or Control</b>	<b>Description</b>
 <b>Mark Reviewed</b>	<p>Click to update the applicant's disposition to <i>020 - Reviewed</i>. Because this action always uses the disposition with status code 020, you should not modify this delivered disposition.</p>
 <b>Route</b>	<p>Click to perform the Route Applicant action.</p> <p>If the applicant has at least one existing routing for this job opening, this action displays the <a href="#">Manage Routings Page</a>. If the applicant does not yet have any routings, this action displays the <a href="#">Route Applicant Page</a>.</p>
 <b>Interview</b>	<p>Click to perform the Manage Interviews action.</p> <p>If the applicant has at least one existing interview for this job opening, , this action displays the <a href="#">Manage Interviews Page</a>. If the applicant does not yet have any interviews, this action displays the <a href="#">Interview Schedule Page</a>.</p>
 <b>Reject</b>	<p>Click to perform the Reject Applicant action, which displays the <a href="#">Reject Applicant Page</a>.</p>
 <b>Print</b>	<p>Click to access the <a href="#">Application Report Options Page</a>, where you can choose report parameters and then generate an application details report.</p>

<b>Field or Control</b>	<b>Description</b>
<b>Other Actions</b>	<p>Click to display a menu of actions that you can perform for the job opening shown in the row. The actions appear under two sub-menus.</p> <p>Under the Recruiting Actions sub-menu, you can choose these actions:</p> <ul style="list-style-type: none"> <li>• Create Interview Evaluation</li> <li>• Create Salary Package Model</li> </ul> <p>This action is available only to recruiting administrators, and only if PeopleSoft Global Payroll for Australia is installed.</p> <ul style="list-style-type: none"> <li>• Prepare Job Offer</li> <li>• Accept Offer</li> </ul> <p>This action is available only if there is an offer in the default open status.</p> <ul style="list-style-type: none"> <li>• Reject Offer</li> </ul> <p>This action is available only if there is an offer in the default open status.</p> <ul style="list-style-type: none"> <li>• Withdraw Application</li> </ul> <p>This action is available only if disposition <i>130 Withdrawn Application</i> is configured as a successor of the current disposition.</p> <ul style="list-style-type: none"> <li>• Prepare for Hire</li> </ul> <p>This action is available only if the current disposition is <i>071 - Offer Accepted</i>, <i>080 - Ready to Hire</i>, or <i>090 - Hired 120 - Withdrawn</i>.</p> <ul style="list-style-type: none"> <li>• Withdraw from Hire</li> </ul> <p>This action is available only if the current disposition is <i>080 - Ready to Hire</i>.</p> <ul style="list-style-type: none"> <li>• Edit Application Details</li> <li>• Edit Disposition</li> </ul> <p>If a flexible recruiting process governs the job opening, this is available only if the process provides the user with valid transitions from the current disposition.</p>

<b>Field or Control</b>	<b>Description</b>
	<p>Under the Application Actions sub-menu, you can choose these actions:</p> <ul style="list-style-type: none"> <li>• Send Correspondence</li> <li>• Add POI</li> </ul> <p>This action is available only for external applicants.</p> <ul style="list-style-type: none"> <li>• Copy Salary Package</li> </ul> <p>This action is available only to recruiting administrators, and only if PeopleSoft Global Payroll for Australia is installed and the applicant's disposition is <i>Hired</i>.</p> <ul style="list-style-type: none"> <li>• Manage Applicant Checklists</li> <li>• Manage Applicant Contracts</li> <li>• Pre-Employment Check</li> </ul> <p>See <a href="#">Understanding Actions for Managing Applicants</a>.</p>
<b>Select All and Deselect All</b>	<p>Use these links to select or deselect grid rows so that you can perform group actions on the selected rows.</p>

<b>Field or Control</b>	<b>Description</b>
<b>Group Actions</b>	<p>Click to display a menu of actions that you can perform for the selected job openings. The actions appear under two sub-menus.</p> <p>Under the Recruiting Actions sub-menu, you can choose these actions:</p> <ul style="list-style-type: none"> <li>• Mark Reviewed</li> <li>• Reject Applicant</li> <li>• Route Applicant</li> <li>• Withdraw Application</li> <li>• Edit Application Details</li> <li>• Print Applications</li> </ul> <p>Under the Applicant Actions sub-menu, you can choose the Send Correspondence action.</p> <hr/> <p><b>Note:</b> The number of rows that can be included in a group action can be limited using the Group Action Limit field on the <a href="#">Recruiting Installation – Applicants Page</a>. If a user attempts to perform a group action when too many rows are selected, the system displays a message informing the user of the limit and stating that only the allowed number of rows will be processed. If the user continues, the system processes the allowed number of rows, starting at the beginning of the list and following the grid sort order. Even if the user cancels, the system deselects all rows after the specified limit, and the user can review which rows will be processed before re-initiating the action with an allowable number of selected rows.</p> <hr/>

## Configuring the Columns in the Applicant Activity Grid

Follow these steps to hide or relabel the columns in the applicant activity grid:

1. Navigate to **Enterprise Components** > **Page and Field Configurator** and add a new value with component name *HRS\_MANAGE\_APP*, Market *Global*, and Configuration Type *Standard*. Enter description as *Manage Applicants*.
2. Select **Select Fields** and choose the fields that you wish to hide or relabel. Select the check box under **Hide Field** column for the fields you want to hide from the Applicant Activity grid. You can also relabel the fields by selecting the check box under **Modify Label** column and entering the required label. Save the configuration.

3. Under the **Map to Portal Registry** tab, select the row for *EMPLOYEE* and select **Apply Configuration**. You can see that the **Review/Edit Mapping** link is enabled after you apply the configuration.
4. Select **Review/Edit Mapping** to open the Event Mapping Configuration page. Uncheck the **Enabled** field for component with Event Name *PostBuild*.
5. Add a new row under Event Mapping Configuration with the below details and save the page:
  - Event Level: Page
  - Page or Record or Record Field: HRS\_MANAGE\_APP
  - Event Name: Activate
  - Service ID/Application Package: Copy the Service ID from the row for component with Event Name *PostBuild*
  - Processing Sequence: Post
  - Enabled: select the check box

This example illustrates the Event Mapping Configuration for Manage Applicant page.

Event Mapping Configuration									
Event Mapping Configuration									
Content Reference: Manage Applicant									
Event Level	Unrestricted Prompt	Page or Record or Record Field	Event Name	Service ID/Application Package	Processing Sequence	Event Map Parameter	Sequence Number	Enabled	
1	Record	<input type="checkbox"/>	HRS_RCMINT	Rowinsert	E00C_ROWINSERT1 E00C_COMP_CONFIG Services CompRecord_Rowinsert	Post		<input checked="" type="checkbox"/>	+ -
2	Record	<input type="checkbox"/>	HRS_RCMINT	Rowinit	E00C_ROWINIT1 E00C_COMP_CONFIG Services CompRecord_Rowinit	Post		<input checked="" type="checkbox"/>	+ -
3	Component	<input type="checkbox"/>		SavePreChange	E00C_SAVEPRECHANGE E00C_COMP_CONFIG Services Component_SavePreChange	Post		<input checked="" type="checkbox"/>	+ -
4	Component	<input type="checkbox"/>		PostBuild	E00C_POSTBUILD E00C_COMP_CONFIG Services Component_PostBuild	Post		<input type="checkbox"/>	+ -
5	Page	<input type="checkbox"/>	HRS_MANAGE_APP	Activate	E00C_POSTBUILD E00C_COMP_CONFIG Services Component_PostBuild	Post		<input checked="" type="checkbox"/>	+ -

## Applicant Resume Page

Use the Applicant Resume page (HRS\_APP\_RESUME) to view a resume that was copied into the resume text field.

Navigation:

Click the **Resume** icon on the Manage Applicant page: Applicant Activity tab: Current Status section.

This example illustrates the Applicant Resume page.

### Applicant Resume

**Applicant Name** George Kelly  
**Resume Title** George Kelly Resume

# George Kelly

1123 Lincoln Avenue  
Sequoia Heights, Nevada  
111-222-3333  
george.kelly@email.com

#### Professional Summary

- XXX	- XXX
- XXX	- XXX
- XXX	- XXX

#### Experience

- XXX
- XXX

#### Education

- XXX
- XXX

## Manage Applicant page: Applicant Activity Tab: Interview Schedule/Evaluation Section

Use the Manage Applicant page: Applicant Activity tab: Interview Schedule/Evaluation section (HRS\_MANAGE\_APP) to review and manage the applicant’s interviews and interview evaluations.

Navigation:

Access the [Manage Applicant Page](#), then click the Interview Schedule/Evaluation link on the Applicant Activity tab.

This example illustrates the Manage Applicant page: Applicant Activity tab: Interview Schedule/Evaluation section.

**Manage Applicant**

Save | Return | Recruiting Home | Search Applicants | Previous | Next | Create Applicant | Add Note | Add to List | Add Application | >> Personalize

Name Roslyn Patty  
 Applicant ID 500262  
 Applicant Type External Applicant  
 Status 010 Active

Preferred Contact Email  
 Phone 578/479-2367  
 Email roslyn.patty@oraclesample.com  
 Address

Applicant Activity | Notes | Applicant Data | Interested Parties

Current Status | Interview Schedule/Evaluation | Expenses | History

**Interviews**

Date	Start Time	End Time	Time Zone	Name	Location	Job	Comments
07/27/2012	9:00AM	10:00AM	PST	Douglas Lewis	548 Sydweigh Boulevard San Francisco	General Office Clerk	

Create Interview

**Interview Evaluations**

Name	Job	Interview Rating	Interview Type	Recommendation	Score	Action
Douglas Lewis	General Office Clerk		Campus		0.000	Evaluate Applicant
Jean Parsons	General Office Clerk		Campus		0.000	Evaluate Applicant
Betty Locherty	General Office Clerk	Excellent	Campus	020 Make Offer	8.000	Complete Evaluation

Create New Evaluation

**Note:** This page is not affected flexible recruiting processes. That is, even if a flexible recruiting process restricts access to the Manage Interviews action or the Create Interview Evaluation action for some job openings, it does not impact the availability of any of the buttons or links on this page.

## Interviews

This grid lists the applicant’s interviews.

<b>Field or Control</b>	<b>Description</b>
<b>Date, Start Time, End Time, and Time Zone</b>	These fields indicate when the interview is scheduled.  The date is also a link that you can click to access the <a href="#">Interview Schedule Page</a> .
<b>Name</b>	Displays the name of the first interviewer.
<b>Location</b>	Displays the interview location.
<b>Job</b>	Displays the posting title of the job opening for which the applicant is interviewing. Click this link to access the Manage Job Opening page.
<b>Comments</b>	Click to display a read-only dialog box with any applicant-related comments that were entered in the interview schedule.



<b>Field or Control</b>	<b>Description</b>
<b>Create Interview</b>	Click this link to access the Interview Schedule page to schedule a new interview. If the applicant is linked to more than one job opening, the <a href="#">Select Job Opening for Interview Page</a> appears first so that the user can identify the opening for which the applicant is interviewing.

## Interview Evaluations

After an interview's date and time have passed, the system automatically adds all scheduled interviewers to this grid. This grid lists all scheduled interviewers along with summary information about each interviewer's evaluation.

<b>Field or Control</b>	<b>Description</b>
<b>Name</b>	Displays the name of the interviewer. An interviewer who participates in multiple interviews has multiple rows in this grid.
<b>Job</b>	Displays the posting title for the job opening for which the applicant interviewed. If the interview is for an application without a job opening, this field displays <i>No Job Opening Selected</i> .
<b>Interview Rating</b>	Displays the interview rating entered by the evaluator.
<b>Interview Type</b>	Displays the interview type. The default interview type for an evaluation is the interview type specified on the Interview Schedule page. However, an evaluator can override that default for a specific evaluation.
<b>Recommendation</b>	Displays the recommendation entered by the evaluator.
<b>Score</b>	Displays the total score for the evaluation. This score is the sum of the scores for the individual evaluation categories in the evaluation. If the evaluator hasn't yet entered a rating for a category, the score for that category is zero.

<b>Field or Control</b>	<b>Description</b>
<b>Action</b>	<p>Displays text that indicates the status of the evaluation. When appropriate, the Action column text is a link that the user clicks to access the Interview Evaluation page. Values in this column include:</p> <ul style="list-style-type: none"> <li> <p><i>Evaluate Applicant:</i> This appears when the evaluation has not yet been started.</p> <p>This is an active link only for an evaluator's own evaluation. Clicking the link displays the Interview Evaluation page, where the evaluator can begin the evaluation.</p> </li> <li> <p><i>Complete Evaluation:</i> This appears when the evaluation has been saved, but not yet submitted.</p> <p>This is an active link only for an evaluator's own evaluation. Clicking the link displays the Interview Evaluation page, where the evaluator can continue to work on the evaluation.</p> </li> <li> <p><i>View Evaluation:</i> This appears when the evaluation has been submitted.</p> <p>This link is active regardless of who created the evaluation. Clicking the link displays the Interview Evaluation page in read-only mode.</p> </li> <li> <p><i>Edit Evaluation:</i> Administrators see this instead of <i>View Evaluation</i> if you enabled administrator evaluation edits by selecting <i>Yes</i> in the Administrator Evaluation Edit field on the <a href="#">Recruiting Installation – Applicants Page</a>.</p> <p>Clicking this link displays the Interview Evaluation page, but in this mode, the Save and Submit Evaluation buttons are replaced by buttons that the administrator can use to edit, delete, or send back the completed evaluation.</p> </li> </ul>
<b>Create New Evaluation</b>	<p>Click this link to access the Interview Evaluation page to create a new evaluation. If the applicant is linked to more than one job opening, the <a href="#">Select Job Opening for Interview Page</a> appears first so that you can identify the opening to which the evaluation pertains.</p>

## Manage Applicant Page: Applicant Activity Tab: Expenses Section

Use the Manage Applicant page: Applicant Activity tab: Expenses section (HRS\_MANAGE\_APP) to manage applicant-related expenses.

Navigation:

Access the Manage Applicant Page, then click the Expenses link on the Applicant Activity tab.

This example illustrates the Applicant Activity tab: Expenses section.

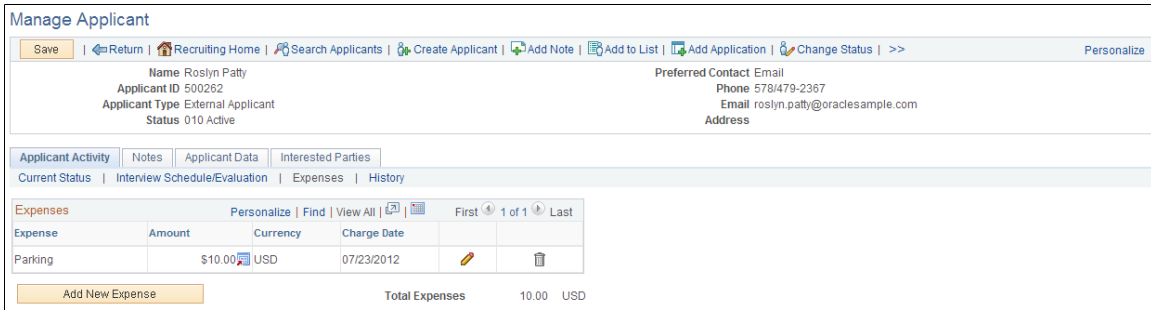

<b>Field or Control</b>	<b>Description</b>
<b>Expense, Amount, Currency, and Charge Date</b>	These fields display summary information about the expense.
 <b>Edit</b>	Click to access the Expenses page, where you can view and modify the complete expense details.
<b>Add New Expense</b>	Click to open the Expenses page and enter a new expense.

## Expenses Page

Use the Expenses page (HRS\_APP\_EXP\_SP) to enter details about an applicant-related expense.

Navigation:

On the Manage Applicant page: Applicant Activity tab: Expenses section, click the **Add New Expense** button or click the Edit icon for an existing expense.

This example illustrates the Expenses page.

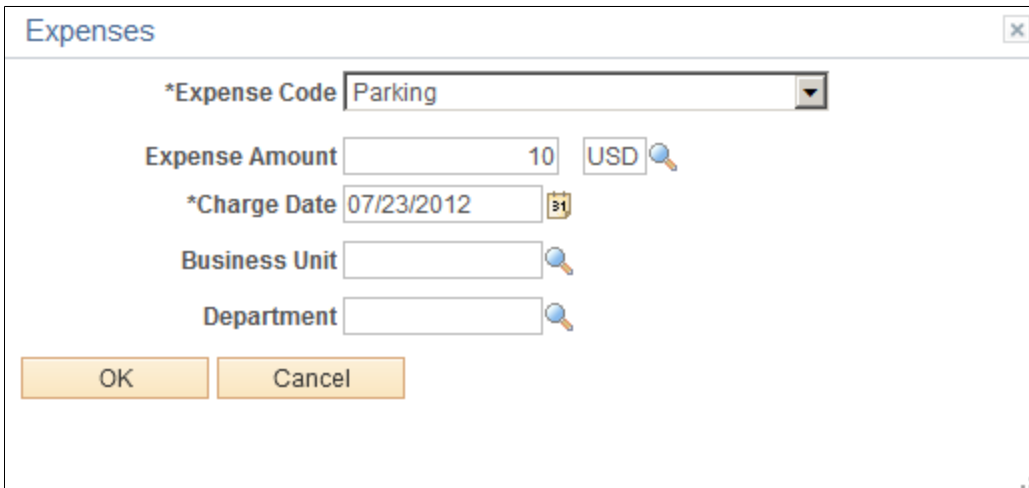

<b>Field or Control</b>	<b>Description</b>
<b>Expense Code</b>	Select an expense code, such as airfare, car rental, travel, or parking.
<b>Expense Amount</b>	Enter the expense amount and select a currency.
<b>Charge Date</b>	Enter the date on which the expense occurred.
<b>Business Unit</b>	Select the business unit to which the expense should be charged.
<b>Department</b>	Select the department to which the expense should be charged.
<b>Add Expense</b>	Click to save your data and return to the Manage Applicant page.

## Manage Applicant Page: Applicant Activity Tab: History Section

Use the Manage Applicant page: Applicant Activity tab: History section (HRS\_MANAGE\_APP) to view the applicant’s disposition history for all job openings.

Navigation:

Access the [Manage Applicant Page](#), then click the History link on the Applicant Activity tab.

This example illustrates Manage Applicant page: Applicant Activity tab: History section.

**Manage Applicant**

[Save](#) | [Return](#) | [Recruiting Home](#) | [Search Applicants](#) | [Previous](#) | [Next](#) | [Create Applicant](#) | [Add Note](#) | [Add to List](#) | [Add Application](#) | [Personalize](#)

**Name** Roslyn Patty      **Preferred Contact Email**  
**Applicant ID** 500262      **Phone** 578/479-2367  
**Applicant Type** External Applicant      **Email** roslyn.patty@oraclesample.com  
**Status** 010 Active      **Address**

[Applicant Activity](#) | [Notes](#) | [Applicant Data](#) | [Interested Parties](#)  
[Current Status](#) | [Interview Schedule/Evaluation](#) | [Expenses](#) | [History](#)

Job Opening	Job Opening ID	Disposition	Reason	Last Updated	Last Updated By
Administrative Support Supervisor	504003	010 Applied		06/15/2012 11:45PM	Betty Locherty
Administrative Support Supervisor	504003	020 Reviewed		06/29/2012 1:45AM	Betty Locherty
Administrative Support Supervisor	504003	100 Hold		09/04/2012 3:56PM	Betty Locherty
Billing Manager - Medical Claims	504024	010 Applied		07/27/2012 11:24AM	Betty Locherty
General Office Clerk	504001	010 Applied		07/27/2012 11:26AM	Betty Locherty
General Office Clerk	504001	060 Interview		07/27/2012 11:42AM	Betty Locherty
Executive Services Administrator	504004	010 Applied		07/27/2012 11:27AM	Betty Locherty
Executive Services Administrator	504004	030 Screen		09/04/2012 3:06PM	Betty Locherty
Executive Services Administrator	504004	020 Reviewed		09/04/2012 3:43PM	Betty Locherty
No Job Opening Selected		010 Applied		06/15/2012 11:15PM	Betty Locherty

<b>Field or Control</b>	<b>Description</b>
<b>Job Opening and Job Opening ID</b>	<p>These fields identify the job whose disposition history is shown.</p> <p>For each job opening, the grid includes separate rows for every disposition that has been applied.</p> <p><i>No Job Opening Selected</i> indicates an application without a job opening.</p> <p><i>Job Title Not Available</i> indicates that the applicant withdrew the application before submitting it. Normally withdrawing an unsubmitted application makes the application invisible in Talent Acquisition Manager. But in the rare situation where a recruiting administrator takes action on one application from a draft multi-job application, and then the applicant withdraws the multi-job application, a history row remains for the job opening that was acted on.</p>
<b>Disposition</b>	Displays the applicant's current or previous disposition for the job opening.
<b>Reason</b>	<p>Displays the reason that was supplied at the time the disposition was assigned (if any).</p> <p>If the <b>Require Reason Upon Manual Reject</b> field on the <b>Recruiting Installation – Applicants Page</b> is set to <i>Yes</i>, then the <b>Reject Applicant</b> action requires users to supply a reason.</p>
<b>Last Updated</b>	Displays the date that the disposition was applied.
<b>Last Updated By</b>	Displays the name of the person whose action caused the disposition to be applied.

## Manage Applicant Page: Notes Tab

Use the Manage Applicant page: Notes tab (HRS\_MANAGE\_APP) to review and create notes for applicants.

Navigation:

Access the [Manage Applicant Page](#), then click the Notes tab.

This example illustrates the Manage Applicant page: Notes tab.

**Manage Applicant**

Save | Return | Recruiting Home | Search Applicants | Create Applicant | Add Note | Add to List | Add Application | Change Status | >> Personalize

Name: Brian Waters  
 Applicant ID: 300051  
 Applicant Type: External Applicant  
 Status: 010 Active

Preferred Contact: Not Specified  
 Phone:  
 Email:  
 Address:

Applicant Activity | **Notes** | Applicant Data | Interested Parties

**Notes Summary**

Select	Subject	Note Date	Author	Personalize
<input checked="" type="radio"/>	Offer Letter	08/30/2017 10:24AM	Jake Oglevy	
<input type="radio"/>	Please review	08/30/2017 10:23AM	Jake Oglevy	
<input type="radio"/>	Confirmed interview	08/30/2017 10:22AM	Jake Oglevy	
<input type="radio"/>	Interview Request	08/30/2017 10:21AM	Jake Oglevy	

**Note Details**

Author: Jake Oglevy  
 Date: 08/30/2017  
 Contact Method: Outbound Letter  
 Note Audience: Public

**Job Openings**

Job Opening ID	Posting Title
305113	Office Assistant

Subject: Offer Letter  
 Details: Letter of offer generated on 2017-08-30 by user HCQAN-R

**Attachments**

File Name	Description	Date Added	Added By
2017-08-30-10.24.20.0000001037HRS_OFF_LET.rtf	Offer Letter	08/30/2017 10:24AM	Jake Oglevy

Add Applicant Note

See [Working With Applicant Notes](#).

## Manage Applicant page: Applicant Data Tab

Use the Manage Applicant page: Applicant Data tab (HRS\_MANAGE\_APP) to view or modify an applicant's personal information, references, and eligibility & Identity information.

Navigation:

Access the [Manage Applicant Page](#), then click the Applicant Data tab.

This example illustrates the Manage Applicant page: Applicant Data tab.

**Manage Applicant**

Save | Return | Recruiting Home | Search Applicants | Previous | Next | Create Applicant | Add Note | Add to List | Add Application | >> Personalize

Name: Jan Bradley  
 Applicant ID: 2  
 Applicant Type: External Applicant  
 Status: 010 Active

Preferred Contact: Phone  
 Phone: 510/562-2333  
 Email: HCMGENUser1@ap6023fems.us.oracle.com  
 Address: 1923 Roble Road Berkeley, CA 94706

Applicant Activity | Notes | **Applicant Data** | Interested Parties

Personal Information | References | Eligibility & Identity

**Applicant**

\*Applicant Type: External Applicant  
 Preferred Contact: Phone

**Applicant Status**

\*Status Code: Active  
 Status Reason:  
 Status Date: 08/30/2001  
 Registered Online: Yes  
 Inactivate Online Account

**Name**

Name Format: English  
 Name Prefix: Miss  
 \*First Name: Jan  
 Middle Name:  
 \*Last Name: Bradley  
 Name Suffix:

**Address**

Country: United States  
 Address 1: 1923 Roble Road

**Email Addresses**

Primary	*Email Type	Email Address
<input checked="" type="checkbox"/>	Home	HCMGENUser1@ap6023fems.us.oracle.com

Add Email Address

**Phone Numbers**

Primary	*Phone Type	Telephone	Extension	Country Code
<input checked="" type="checkbox"/>	Cellular	510/562-2333		

Add Phone Number

## Applicant Data

This tab provides access to the same applicant data that you enter on the Create Applicant page. The subsections correspond to the [Create Applicant Page: Personal Information Tab](#), the [Create Applicant Page: References Tab](#), and the [Create Applicant page: Eligibility & Identity Tab](#). Only recruiting administrators have access to the Eligibility & Identity section.

These page elements on the Personal Information tab are visible on the Manage Applicant page, but they are not visible in Create Applicant mode:

<b>Field or Control</b>	<b>Description</b>
<b>Registered Online</b>	<p>This field is not visible in add mode (on the Create Applicant page), but it appears when you view personal information on the Manage Applicant page: Applicant Data page.</p> <p>This read-only field displays <i>Yes</i> or <i>No</i> to indicate whether the applicant is a registered user of Candidate Gateway. The value remains <i>Yes</i> even if the Candidate Gateway account is deactivated.</p>
<b>Inactivate Online Account</b>	<p>This field is visible only if the <b>Registered Online</b> field is <i>Yes</i>. Like the <b>Registered Online</b> field, is it not visible in add mode (on the Create Applicant page). Instead, it appears when you view personal information on the Manage Applicant page: Applicant Data page.</p> <p>Select this check box to make the applicant's Candidate Gateway account inactive. Deselect the checkbox to reactivate the account.</p> <p>You cannot reactivate accounts that deactivated by the applicant merge process. The system recognizes such accounts by their status, which indicates that the account was a duplicate.</p>

---

**Note:** The system displays warning messages when any address fields are left blank. If it is not a mandatory field, the user can ignore the message and save the data.

---

## Application Details

The Manage Applicant page does not have a subsection that corresponds to the [Create Applicant Page: Applications Tab](#). To view or edit application details, go to the [Manage Applicant page: Applicant Activity Tab: Current Status Section](#). Click the Manage Application icon to view the application details within the context of all recruiting activity for the applicant and the job opening, or use the **Other Actions > Recruiting Actions > Edit Application Details** action to open the Application Details page.

## Manage Applicant page: Interested Parties Tab

Use the Manage Applicant page: Interested Parties tab (HRS\_MANAGE\_APP) to identify interested parties so that they can be easily copied on email correspondence.

Navigation:

Access the [Manage Applicant Page](#), then click the Interested Parties tab.

This example illustrates the Manage Applicant page: Interested Parties tab.

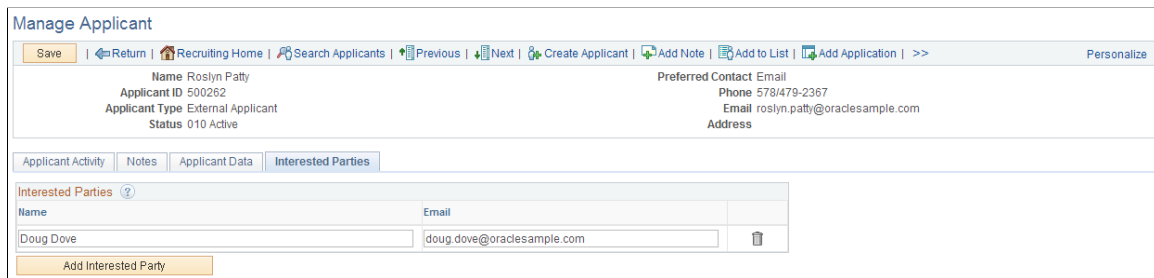

### Interested Parties

Use this group box to enter the names and email addresses of interested parties. When you send correspondence to an applicant, you can select the **Include Interested Parties** option on the [Send Correspondence Page](#) to send email correspondence to the persons that you list here.

## Working With Applicant Notes

This topic discusses applicant notes.

### Pages Used to Work With Applicant Notes

<i>Page Name</i>	<i>Definition Name</i>	<i>Usage</i>
<a href="#">Manage Applicant Page: Notes Tab</a>	HRS_MANAGE_APP	Review and create notes for applicants.
<a href="#">Applicant Notes Page</a>	HRS_APP_NOTES	View or modify details and attachments for an applicant-related note.

## Understanding Applicant Notes

This section provides an overview creating, viewing, and editing applicant notes.

### Creating Notes

Users can manually create applicant notes and optionally add attachments to the notes.

Additionally, the system automatically creates applicant notes during recruiting process such as:



- Forwarding an applicant.
- Sending correspondence.
- Generating a letter.

Users can generate interview letters, offer letters, and generic applicant letters. When letter generation creates a note, the letter itself becomes an attachment to the note.

- Linking an applicant to a job opening with a questionnaire.

The note is created only if the system sends the applicant an invitation to apply. The invitation is sent if the applicant has an email address and the job opening with the questionnaire is currently posted to Candidate Gateway.

- Scheduling an interview.

The note is created only if the **Notify Applicant** option is selected when the user submits the interview schedule.

- Posting an offer to Candidate Gateway.
- Using Candidate Gateway to accept or reject an offer (this action is performed by the applicant).
- Using Candidate Gateway to send documents to a recruiter (this action is performed by the applicant).

Documents that the applicant sends become attachments to the note.

## Viewing Notes

Note visibility depends on whether the note is marked as public or private. Additionally, for users who are subject to enhanced applicant security, visibility also depends on whether the user has access to any job openings that are associated with the note.

See [Understanding Enhanced Applicant Security](#)

The following table summarizes note visibility based on the user's security type. Keep in mind that enhanced applicant security is activated for specific recruiting role types; it is not a system-wide setting.

<b><i>User's Security Type</i></b>	<b><i>Visible Notes</i></b>	<b><i>Hidden Notes</i></b>
Standard	<ul style="list-style-type: none"> <li>• Private notes where the user is the author.</li> <li>• All public notes.</li> </ul> <p>The note's job openings do not affect note visibility.</p>	Private notes authored by other users.

<b>User's Security Type</b>	<b>Visible Notes</b>	<b>Hidden Notes</b>
Enhanced	<ul style="list-style-type: none"> <li>Private notes where the user is the author.</li> <li>Public notes that are not associated with any job openings.</li> <li>Public notes that are associated with the user's own job openings.</li> </ul> <p>Under enhanced applicant security, the user's own job openings are those where the user is the creator or a member of the hiring team.</p>	<ul style="list-style-type: none"> <li>Private notes authored by other users.</li> <li>Public notes where the user does not have access to any of the associated job openings.</li> </ul>

The following table summarizes how job openings and public/private settings are supplied depending on how the note was created.

<b>Note Source</b>	<b>Job Openings</b>	<b>Public/Private Status</b>
Note is manually created on the Applicant Notes page.	The user manually selects job openings.	The user manually selects a public/private status. The default is public.
Note is automatically created by the Forward Applicant or Send Correspondence action.	<p>If the action is invoked from the context of a job opening, the job opening is carried into the transaction and then into the resulting note.</p> <p>If the action is invoked without the context of a job opening, users can manually add job openings to the transaction.</p>	The user manually selects a public/private status. The default is public.
Note is automatically created by any other process.	<p>The note is associated with the job opening that provided context for the action.</p> <p>For example, the note for an interview letter is associated with a job opening if the interview is associated with a job opening.</p> <p>If the interview is for an application without a job opening, then the note is not associated with any job openings.</p>	<p>Public.</p> <p>The note author (the person who performed the original action) can modify the note to make it private.</p>

---

**Note:** When enhanced applicant security is enabled for at least one recruiting role type, the Applicant Notes page includes instructional text to explain how the job openings and the public/private setting affect note visibility. This instructional text is displayed to all users.

---

## Modifying Note Details

The Manage Applicant Page: Notes tab displays read-only details of selected notes. To modify a note, the note author clicks the Edit Note button to open the Applicant Notes detail page. Authors can modify both manual and system-generated notes.

When a non-author opens clicks the Edit Note button, the Applicant Notes page is read-only.

Notes created by the Forward Applicant and Send Correspondence actions are different. For these notes:

- Authors can resend the original message or a modified version of it, but they cannot modify the original note.

The Edit Note button for these notes does not open the usual Applicant Notes detail page. Instead, the Edit Note button displays the original transaction page (either the Forward Applicant page or the Send Correspondence page). In this mode, those pages have a Resend button, and the author can resend with the original text or with modified text.

- For notes created by the Send Correspondence action, non-authors can also resend the correspondence.
- For notes created by the Forward Applicant action, the behavior depends on the user's security type:
  - Non-authors with standard security can resend the message.
  - Non-authors with enhanced applicant security cannot view the message portion of the note, nor can they resend the message. For these users, the Edit Note button is not available, and the detail area of the Notes tab replaces the original message with the text *Applicant <name> is forwarded to <recipients>*. To and cc recipients are listed, but bcc recipients are not listed.

## Manage Applicant Page: Notes Tab

Use the Manage Applicant page: Notes tab (HRS\_MANAGE\_APP) to review and create notes for applicants.

Navigation:

Access the [Manage Applicant Page](#), then click the Notes tab.



This example illustrates the Manage Applicant page: Notes tab.

The screenshot shows the 'Manage Applicant' interface for Brian Waters. It includes a navigation bar with options like 'Save', 'Return', and 'Add Note'. The applicant's details are listed, including Name, ID, Type, and Status. Below this is a 'Notes Summary' table with columns for 'Select', 'Subject', 'Note Date', and 'Author'. The selected note details show it was an 'Outbound Letter' sent on 08/30/2017. It also displays 'Job Openings' for an 'Office Assistant' position and a list of 'Attachments' with file names, descriptions, and dates.

## Notes Summary

This grid lists both manually-created and system-generated notes to which the user has access.

<b>Field or Control</b>	<b>Description</b>
<b>Select</b>	Select a note to display the note in its entirety in the <b>Note Details</b> group box below the summary grid.
<b>Subject</b>	<p>Displays the subject of the note.</p> <p>The author provides the subject for manually created notes, for Forward Applicant notes, and for Send Correspondence notes.</p> <p>The system provides the subject for other automatically-generated notes. Examples of system-generated subjects are <i>Interview Letter</i>, <i>Interview Request</i>, <i>Offer Letter</i>, and <i>Online Job Offer Posted</i>.</p>
 <b>Attachment</b>	<p>The <b>Attachments</b> icon appears if the note has attachments. This column is hidden if none of the notes have attachments.</p> <p>The icon is just a visual indicator that an attachment exists; it is not clickable.</p>

<b>Field or Control</b>	<b>Description</b>
<b>Note Date and Author</b>	<p>These fields show when the note was created and who created it.</p> <p>For automatically generated notes, the author is the user (or applicant) who performed the action that generated the note.</p>
 <b>Edit</b>	<p>Click to access the detail page for the note.</p> <p>For most notes, the Applicant Notes page opens. The note author can edit the note, but the page is read-only for non-authors.</p> <p>For notes based on email that is generated by the Forward Applicant or Send Correspondence action, clicking the Edit button opens the original transaction page. Users can resend the forwarding or the correspondence from this page, but they cannot modify the original note. (Send Correspondence actions that send letters rather than email behave like other notes and open the Applicant Notes page).</p> <p>Users who are subject to enhanced applicant security cannot access the detail page for notes that were created when a different user forwarded an applicant. In this scenario, the Edit icon is disabled.</p>
 <b>Delete</b>	<p>Click the <b>Delete</b> icon to remove a note. Only the author of a note can delete it.</p>

## Note Details

This group box displays read-only information about the note that is selected in the summary grid. The fields correspond to the same-named fields on the Applicant Notes detail page.

<b>Field or Control</b>	<b>Description</b>
<b>Edit Note</b>	<p>This link is the same as the <b>Edit Note</b> icon in the summary grid.</p>
<b>Message</b>	<p>Typically this field shows the body of the note. However, there is one exception. Non-authors with enhanced applicant security are not allowed to view the full message for notes that were created when a different user forwarded an applicant. In this scenario, the message field displays the text <i>Applicant &lt;name&gt; is forwarded to &lt;recipient email address&gt;</i>.</p>

## Add Applicant Note

Field or Control	Description
Add Applicant Note	Click to open the Applicant Notes page and enter a new note.

## Applicant Notes Page

Use the Applicant Notes page (HRS\_APP\_NOTES) to enter applicant-related notes and attachments.

Navigation:

- On the Manage Applicant page, click the Add Note icon in the toolbar at the top of the page.
- On the Manage Applicant page: Notes tab, click the **Edit Note** icon for an existing note, or click the **Add Applicant Note** button.

This example illustrates the Applicant Notes page. In this example, enhanced applicant security is active, so the page displays instructional text that would not be there if all users had standard security.

**Applicant Notes** ✕

The access setting affects who can see the applicant note.  
 Private notes can only be seen by the author.  
 Public notes that are not associated with any job openings are visible to all users.  
 Public notes that are associated with job openings are visible to the job openings' hiring teams and creators. They are also visible to administrators and any other users who have unrestricted access to all applicant data.

Author: Betty Locherty Contact Method: Outbound Email

Date: 08/30/2017 \*Audience: Public

**Job Openings** Personalize | Find | View All | 1 of 1 | First | Last

Job Opening ID	Posting Title	
800013	Developer/Analyst	✕

Add Job Opening

\*Subject: Interview confirmation

Details: Exchanged email regarding a convenient interview date and time. Interview will be scheduled for Tuesday Sept 5 at 4pm. 📎

**Attachments** Personalize | Find | View All | 1 of 1 | First | Last

File Name	Description	
interview_confirmation.eml	Email conversation	✕

Add Attachment

Save
Cancel

<b>Field or Control</b>	<b>Description</b>
<b>&lt;Instructional Text&gt;</b>	<p>If enhanced applicant security is enabled for at least one recruiting role type, instructional text at the top of the page explains how the combination of the note's job openings and the note's public/private setting affect which users can see the note.</p> <p>See <a href="#">Understanding Enhanced Applicant Security</a></p>
<b>Author</b>	<p>Displays the name of the person who created the note. If the note is system-generated, the author is the person who performed the action that generated the note.</p>
<b>Contact Method</b>	<p>Select a contact method, choosing from the methods that are defined on the <a href="#">Contact Methods Page</a>.</p>
<b>Date</b>	<p>Displays the note creation date. Although this field is editable, the system populates it with the actual note creation date, and you typically should not change this.</p>
<b>Audience</b>	<p>Select <i>Public</i> or <i>Private</i> to control who can see the note.</p> <p>Private notes are only visible to the author.</p> <p>The visibility of public notes depends on the user's security type. Users with standard security can see all public notes. Users with enhanced applicant security can see notes that have no job openings and notes that are associated with the user's own job openings.</p> <p>For more information, see <a href="#">Understanding Applicant Notes</a> and <a href="#">Understanding Enhanced Applicant Security</a>.</p>

<b>Field or Control</b>	<b>Description</b>
<b>Job Openings</b>	<p>Use this grid to associate the note to one or more job openings. You can only select job openings to which you have access. All users have access to job openings that they created and where they are on the hiring team. Users with standard applicant security can additionally access job openings if they the department security tree gives the user access to the job opening’s department. Users with enhanced applicant security do not gain access to job openings through the department security tree.</p> <p>If a note is associated with job openings, users with enhanced applicant security can view the note only if they have access to at least one of the job openings.</p> <p>Job openings do not affect note visibility for users with standard security.</p> <p>This grid is editable only when you first create the applicant note. After you save the note, you can still access this page and edit most note information, but the <b>Job Openings</b> grid becomes read-only.</p> <p>When the system generates a note from the context of a job opening, that job opening is automatically associated with the note.</p>
<b>Add Job Opening</b>	<p>Click this button to add additional rows to the <b>Job Openings</b> grid. This button is visible only when you are creating anew note. When you access an existing note, this button is hidden because the <b>Job Openings</b> grid is read-only.</p>
<b>Subject and Details</b>	<p>Use these fields to enter the note content.</p>
<b>Attachments</b>	<p>Use this group box for attachments that pertain to the note. Click the <b>Add Attachment</b> button to upload a file attachment.</p>
<b>Save</b>	<p>This button is visible only when you create a new note. Click the button to save the note and return to the Manage Applicant page: Notes tab.</p> <p>After you save a new note, the <b>Job Openings</b> grid is no longer editable.</p> <p>If enhanced applicant security is active for at least one recruiting role type, the note has no job openings, and the audience is <i>Public</i>, saving triggers a warning message that the note will be visible to all users. This gives the author an opportunity to protect sensitive information by editing the note or by associating the note with the relevant job opening(s).</p>
<b>Update Note</b>	<p>This button replaces the <b>Save</b> button when you view an existing note. If you are the author of the note, you can make changes and then click this button to save the changes.</p>



<i>Field or Control</i>	<i>Description</i>
<b>Cancel</b>	Click to close the Applicant Notes page without saving the note.

## Deleting Applicants

This topic describes how to delete applicants.

### Pages Used to Delete Applicants

<i>Page Name</i>	<i>Definition Name</i>	<i>Usage</i>
<u>Applicant ID Delete Control Page</u>	HRS_APP_EXC_REC	Identify tables where applicant data will not be deleted.
<u>Applicant ID Delete Page</u>	HRS_APP_ID_DELETE	Select applicant to be deleted and run the Applicant ID Delete process.
<u>Applicant ID Delete Log Page</u>	HRS_APP_ID_DEL_LOG	Review the data that was deleted for a specific applicant ID.

## Understanding Application Deletion

Use the Applicant ID Delete (HRS\_APP\_DEL) Application Engine process to delete data for specific applicant IDs that you specify.

### Permission List and Roles

Access to the applicant delete process is available based on the following roles and permission list:

<i>Process Type</i>	<i>Permission List</i>	<i>Delivered Roles With This Permission List</i>
Applicant ID Delete	HCCPHR9600	No role is delivered by Oracle with this permission list. You can add this permission list to any role as per your organization's requirement.

### Deleted Data

The Applicant ID Delete process performs these actions:

- For tables that have HRS\_PERSON\_ID as the key, the process deletes the relevant rows of data.

- For the correspondence, applicant attachment, and offer tables, the process deletes the data related to the applicant that you specify.

The HRS\_PERSON\_ID is neither a key or a foreign key for these types of applicant-related data, so the deletion process includes extra logic to ensure that data for the specified applicant(s) is deleted.

- For tables that have HRS\_PERSON\_ID as a foreign key, the process updates the HRS\_PERSON\_ID value to 0 (zero).

For example, the HRS\_PERSON\_ID field is zeroed out in the Manage Hires tables in PeopleSoft Human Resources.

## Excluding Records from the Deletion Process

The [Applicant ID Delete Control Page](#) enables administrators to specify records to be excluded from the deletion process.

When a user runs the process, the [Applicant ID Delete Page](#) includes a **Skip Record Exclusion Check** option. When this option is selected, the record exclusion settings are ignored and all applicant data is deleted.

Oracle delivers two roles related to the option to exclude records from the deletion process:

- Users with the *ID Delete Administrator* role can edit the exclude records list on the Applicant ID Delete Control page. For other users, this page is display only.
- Users with the *ID Delete User* role can select the option to Skip Record Exclusion Check on the Applicant ID Delete run control page. For other users, this option is disabled.

## Limitations

The Applicant ID Deletion process has the following limitations:

- File attachments that are stored outside of the PeopleSoft database (for example, on an FTP server) are not deleted.
- If you have customized the system, or if you have sent applicant data to third-parties, you are responsible for managing the deletion of the relevant data.

## Applicant ID Delete Control Page

Use the Applicant ID Delete Control page (HRS\_APP\_EXC\_REC) to identify tables where applicant data will not be deleted.

---

**Note:** As delivered, only users with the role *ID Delete Administrator* can modify this page.

---

Navigation:

**Set Up HCM > System Administration > Database Processes > Applicant ID Delete Log**

This example illustrates the Applicant ID Delete Control page.

### Applicant ID Delete Control

**Exclude Records**

☰ 🔍
⏪ ⏩ 1-1 of 1 ⏪ ⏩ | View All

	*Operator	*Record Name		
1	Equal	HRS_SEND_CRSP 🔍	+	-

<i>Field or Control</i>	<i>Description</i>
<b>Operator</b>	Select <i>Equal</i> to exclude the specific record that you specify..  Select <i>Like</i> to exclude records with record names like the string that you specify.
<b>Record Name</b>	Enter the name of the record to be excluded from the deletion process.

**Important!** Users with the *ID Delete User* role can choose whether to check for excluded records when running the Applicant ID Delete process. If a user chooses not to check, then all applicant data is deleted regardless of your exclusion rules.

## Applicant ID Delete Page

Use the Applicant ID Delete page (HRS\_APP\_ID\_DELETE) to select applicant to be deleted and run the applicant delete process.

Navigation:

**Set Up HCM > System Administration > Database Processes > Applicant ID Delete**

This example illustrates the Applicant ID Delete page.

**Applicant ID Delete**

Run Control ID test123 Report Manager Process Monitor Run

**Control Parameters** ⓘ

Skip Record Exclusion Check

**Applicant IDs**

☰ 🔍
⏪ ⏩ 1-1 of 1 ⏪ ⏩ | View All

	*Applicant ID	Name	Address Line 1	Email Address	City	State	Country	Postal Code	
1	7 🔍	George King	2121 California Street		San Francisco	CA	USA	94109	+ -

<i>Field or Control</i>	<i>Description</i>
<b>Run</b>	Click the Run button to access the Process Scheduler Request page, where you can run or schedule the Applicant ID Delete process. Before the Process Schedule Request page appears, the system displays a warning that the deletion process is irreversible.

### Control Parameters

<i>Field or Control</i>	<i>Description</i>
<b>Skip Record Exclusion Check</b>	<p>Select this check box to ignore the <b>Exclude Records</b> settings on the <a href="#">Applicant ID Delete Control Page</a>.</p> <p>This check box is deselected by default. With this default setting, the deletion process does not affect tables that the process is configured to exclude.</p> <p>When you select this check box, all applicant data is deleted.</p> <hr/> <p><b>Note:</b> Only users with the role <i>ID Delete User</i> can modify this setting.</p> <hr/>

### Applicant IDs

<i>Field or Control</i>	<i>Description</i>
<sequence number>	<p>If you enter multiple applicant IDs in the grid, the Applicant ID Delete process runs through each applicant in sequence. The sequence number matches the process sequence number that appears on the <a href="#">Applicant ID Delete Log Page</a>.</p>
<b>Applicant ID</b>	<p>Enter the applicant ID for the applicant to be deleted. The system populates the other columns in the grid with the applicant’s name, address, and email address. This read-only information helps you verify that you’ve entered the correct applicant ID.</p> <p>After you run the deletion process, all applicant data (including the applicant ID) is cleared from the grid.</p>

---

**Note:** The maximum number of rows you can delete is 999.

---

## Applicant ID Delete Log Page

Use the Applicant ID Delete Log page (HRS\_APP\_ID\_DEL\_LOG) to review the data that was deleted for a specific applicant ID.

Navigation:

**Set Up HCM > System Administration > Database Processes > Applicant ID Delete Log**

This example illustrates the Applicant ID Delete Log page.

### Applicant ID Delete Log

<b>Process Instance</b>	196629	<b>Sequence</b>	1
<b>Applicant ID</b>	500245	<b>Date/Time Stamp</b>	10/30/17 2:10:24AM
<b>User ID</b>	PS	<b>Rows Deleted</b>	28

🔍
1-5 of 16
View All

	Record Name	Field Name	Rows Deleted
1	HRS_APPIDXDT_TM	HRS_PERSON_ID	1
2	HRS_APPINDX_CTL	HRS_PERSON_ID	1
3	HRS_APPLICANT	HRS_PERSON_ID	1
4	HRS_APPL_IDX_TM	HRS_PERSON_ID	1
5	HRS_APP_ADDRESS	HRS_PERSON_ID	1

### Process Information

<i>Field or Control</i>	<i>Description</i>
<b>Process Instance</b>	Identifies the specific instance of the Applicant ID Delete process that you are reviewing.
<b>Sequence</b>	The Sequence number reflects the order in which the Applicant ID Delete process handles multiple applicants. For example, if an instance of the process deletes three applicants, the Sequence number 1 is assigned to the first applicant to be deleted and 3 is assigned to the last applicant to be deleted.

<b><i>Field or Control</i></b>	<b><i>Description</i></b>
<b>Applicant ID</b>	<p>Displays the original applicant ID for a single applicant who was deleted.</p> <p>A single instance of the process can delete multiple applicant IDs, but this page displays information for only one applicant at a time.</p>
<b>Date/Time Stamp</b>	Indicates when the Applicant ID Delete process ran. This is the date and time for the process instance, so it is the same for all applicants who were processed together.
<b>User ID</b>	Identifies the user who ran the specified instance of the Applicant ID Delete process.
<b>Rows Deleted</b>	Displays the total number of rows (across all records) that were deleted for the specified applicant.

## Record Details

<b><i>Field or Control</i></b>	<b><i>Description</i></b>
<b>Record Name</b>	Identifies a record where rows were deleted.
<b>Field Name</b>	Identifies the applicant ID field in the record. Typically the value is HRS_PERSON_ID.
<b>Rows Deleted</b>	Displays the number of rows that were deleted from the specified record.

## Chapter 21

# Searching for and Managing Applications

---

## Searching for Applications

This topic provides an overview of application searches and discusses how to search for applications.

### Page Used to Search for Applications

<i>Page Name</i>	<i>Definition Name</i>	<i>Usage</i>
<a href="#">Search Applications Page</a>	HRS_REC_SCHAPPL	Search recruiting records based on a combination of applicant and job opening criteria. Within the search results, you can perform recruiting actions or applicant actions.

### Understanding Application Searches

The Search Application page enables you to search based on a combination of applicant data, job opening data, and data such as an applicant's disposition that has to do with the connection between an applicant and a job opening.

In the context of this search, the term *application* refers to this connection between an applicant and a job opening (or an application without a job opening). Therefore, an applicant who has applied for multiple job openings, or to the same job opening multiple times, can appear in the search results multiple times.

The search results can include unsubmitted applications (applications in draft status).

### Flexible Processing and Applicant Actions

A job opening's flexible recruiting process (if any) defines appropriate actions based on a user's role and an applicant's current disposition. If the flexible recruiting process disallows a particular action, the search results list on the Search Application page does not display the icons or menu commands that would be used to perform the action. Hiding the irrelevant actions helps users to focus on the appropriate next steps in the recruiting process.

These actions can be made unavailable: Reject Applicant, Route Applicant, Manage Interviews, Created Interview Evaluation, Prepare Job Offer, Accept Offer, Reject Offer, Pre-Employment Check, Prepare for Hire, Withdraw from Hire, and Manage Applicant Contracts.

Additionally, the Edit Disposition action is hidden if the flexible recruiting process does not provide the user with any valid disposition transitions.

When a flexible recruiting process makes actions unavailable:

- The search results grid hides icons for unavailable actions, and the column where the icon appears is hidden entirely if an action is not valid for any applicants.
- The Other Actions menu (for performing actions on individual applicants) hides any actions that are not available for the applicant.
- The Group Actions menu does not hide actions, but the system performs the action for only those job openings where the action is permitted.

## Search Applications Page

Use the Search Applications page (HRS\_REC\_SCHAPPL) to search recruiting records based on a combination of applicant and job opening criteria.

Navigation:

**Recruiting > Search Applications**

This example illustrates the Quick Search tab of the Search Applications page.

The screenshot shows the 'Search Applications' page with the 'Quick Search' tab selected. The breadcrumb trail is 'Recruiting Home | Search Applicants | Search Job Openings'. Below the tabs, there is a 'Search Criteria' section with the following fields and options:

- Search My Applicants
- Include Applications Not Linked to a Job Opening
- First Name:
- Last Name:
- Display Name:  ⓘ
- Applicant Status:
- Applied Within:
- Applicant ID:
- Disposition:
- Job Posting Title:
- Job Opening ID:  🔍
- Job Opening Status:
- Category:
- Hiring Manager:  🔍
- Recruiter:  🔍

At the bottom of the search criteria section are two buttons: 'Search' and 'Clear'.



This example illustrates the Advanced Search tab of the Search Applications page.

This example illustrates the Search Results grid of the Search Applications page.

Select	Application	Applicant	Applicant ID	Job Opening	Disposition	Resume	Interest	Mark Reviewed	Route	Interview	Reject	Print	Other Actions
<input type="checkbox"/>		Sonia Nayar	500041	503708 - Bring Your Arbitratio...	060 Interview		☆☆☆X						Other Actions
<input type="checkbox"/>		Krishnan Pallash	500038	503708 - Bring Your Arbitratio...	060 Interview		☆☆☆X						Other Actions
<input type="checkbox"/>		Paulo Coelho	500011	503708 - Bring Your Arbitratio...	060 Interview		☆☆☆X						Other Actions
<input type="checkbox"/>		Ramilio Estavias	500007	503708 - Bring Your Arbitratio...	060 Interview		☆☆☆X						Other Actions

### Toolbar

Field or Control	Description
<b>Recruiting Home</b>	Click to access the <a href="#">Recruiting Home Page</a> .
<b>Search Applicants</b>	Click to access the <a href="#">Search Applicants Page</a> .
<b>Search Job Openings</b>	Click to access the <a href="#">Search Job Openings Page</a> .

### Quick Search Tab: Search Criteria

<b>Field or Control</b>	<b>Description</b>
<b>Search My Applicants</b>	<p>Select this check box to limit the search to applicants who are attached to job openings where you are either the originator or part of the hiring team. This setting does not affect whether the search results include applications that are not associated with any job openings.</p> <p>This check box is hidden from users who are subject to enhanced applicant security. Under enhanced applicant security, users only have access to their own applicants anyway. See <a href="#">Understanding Enhanced Applicant Security</a>.</p> <p>Applicants that you enter into the system are not considered your applicants unless they are associated with one of your job openings.</p> <p>The default setting for this check box is selected.</p>
<b>Include Applications Not Linked to a Job Opening</b>	<p>Select this check box if you want the search results to include applications that are not associated with any job opening in addition to applications that meet any job opening criteria you supply.</p> <p>For example, if you select this check box and also enter the word “Manager” in the Job Posting Title criteria field, the results will include applications without a job opening in addition to applications for jobs with the word “Manager” in the posting title.</p>
<b>First Name, Last Name, and Display Name</b>	Use these fields to search based on the applicant’s name.
<b>Applicant Status</b>	Choose an applicant status to use as search criteria. The default value is the status identified as the default applicant status on the <a href="#">Recruiting Status Area Page</a> . As delivered, the default status is <i>Active</i>
<b>Applied Within</b>	To limit the search to applications that were received within a specific time frame, select one of these time frames: <i>010 - Today, 020 - Yesterday, 030 - Last 3 Days, 040 - Last Week, 050 - Last 2 Weeks, 060 - Last Month, 070 - Last Year, or 080 - View All</i>
<b>Applicant ID</b>	For security reasons, the system does not allow users to prompt for applicant IDs. To search for an applicant using the applicant ID, type the ID into this field.

<b>Field or Control</b>	<b>Description</b>
<b>Disposition</b>	Choose a disposition to use as search criteria.
<b>Job Posting Title</b>	Enter a full or partial job posting title to use as search criteria.
<b>Job Opening ID</b>	Select a job opening ID to use as search criteria.
<b>Job Opening Status</b>	Choose a job opening status to use as search criteria. The default value is the status identified as the default job opening status on the <a href="#">Recruiting Status Area Page</a> . As delivered, the default status is <i>Open</i>
<b>Category</b>	Select one of your personal job opening categories to use as search criteria. The drop-down list displays an alphabetical list of category descriptions.  This field is visible only if job categorization is enabled on the <a href="#">Recruiting Installation – Jobs Page</a> .
<b>Hiring Manager</b>	To search for job openings where a particular person is the primary hiring manager, enter that person's employee ID.
<b>Recruiter</b>	To search for job openings where a particular person is the primary recruiter manager, enter that person's employee ID.
<b>Interest</b>	Interest level indicates your organization's level of interest in a particular applicant for a particular job opening. Unlike the job category, the interest level for an applicant is not specific to the user. The interest level is informational only  A user assigns an interest level to an applicant on the Manage Job Opening page, where the interest level is represented graphically as a one, two, or three star interest level. .  When you search based on interest level, these interest levels appear in the drop-down list box as <i>Low</i> , <i>Medium</i> , and <i>High</i> .  This field is visible only if the <b>Display Interest Indicator</b> field on the <a href="#">Recruiting Installation – Applicants Page</a> is set to <i>Yes</i> .

If the search criteria includes any job opening data, the search returns only job openings to which the user has security access. If there is no job opening data in the search criteria (which necessarily means that the user has not selected the **Search My Applicant** check box.), the results can include applications for job openings to which the user does not have access. However, in this situation, the link to the job opening is disabled, the icons for the application and the resume are hidden, and no actions are available.

## Advanced Search Tab: Search Criteria

The Advanced Search tab includes all of the quick search fields as well as these additional fields:





<b>Field or Control</b>	<b>Description</b>
<b>Applicant Type</b>	Select <i>Employee</i> , <i>External Applicant</i> , or <i>Non-Employee</i> .
<b>Applied Between</b>	Enter a date range for searching based on when an application was received.
<b>Most Recent Activity</b>	<p>To search based on how recently a job opening has had a status change, select the time period to check for status-related activity: <i>Active within Today</i>, <i>Active within Yesterday</i>, <i>Active within Last 3 Days</i>, <i>Active within Last Week</i>, <i>Active within Last 2 Weeks</i>, <i>Active within Last Month</i>, <i>Active within Last Year</i>, or <i>Active within View All</i>.</p> <p>Changes other than status changes are not considered activity for purposes of searching based on when the most recent activity occurred.</p>
<b>Job Opening Type</b>	Select <i>Continuous Job Opening</i> or <i>Standard Requisition</i> .
<b>Hot Job</b>	Select <i>Yes</i> or <i>No</i> to filter results according to whether the job opening is a hot job.
<b>My Association</b>	<p>Select a value representing your association with the job opening. Options are:</p> <ul style="list-style-type: none"> <li>• <i>All Jobs</i>.</li> <li>• <i>Jobs Assigned to me</i>.</li> </ul> <p>A job is assigned to you if you are the primary hiring manager or primary recruiter.</p> <ul style="list-style-type: none"> <li>• <i>Jobs Associated to me</i>.</li> </ul> <p>A job is associated with you if you created it or you are on the hiring team in any capacity.</p> <ul style="list-style-type: none"> <li>• <i>Jobs Created by me</i>.</li> </ul>
<b>Created By</b>	To search for job openings where a particular person created the job opening, enter that person's employee ID.



<b>Field or Control</b>	<b>Description</b>
<b>Business Unit</b>	Use this field to search based on the job opening’s business unit.
<b>Department</b>	Use this field to search based on the job opening’s department. This field is available only after you enter a business unit.
<b>Position Number</b>	Use this field to search based on the position number for the job opening.
<b>Recruitment Contact</b>	Select an external recruitment contact. The drop-down list shows the names of contacts that have been defined on the <a href="#">Contact Setup Page</a> with a contact type of <i>Office</i> .

### Search Results

Each row of search results represents a recruiting record—that is, the connection between an applicant and a job opening. Therefore, both applicant and job opening data appears in each row.

<b>Field or Control</b>	<b>Description</b>
<b>Select</b>	Before performing a group action, use this check box to select the applicants to which the group action applies.
 <b>Application</b>	Click to access the <a href="#">Manage Application Page</a> , where you can review and manage activity related to a single applicant for a single job opening.
<b>Applicant</b>	Displays the applicant’s name. Click the link to access the <a href="#">Manage Applicant Page</a> .
<b>Applicant ID</b>	Displays the applicant’s unique identifier.
<b>Job Opening</b>	Displays identifying information about the job opening, or displays <i>No Job Opening Selected</i> if the row represent an application without a job opening.  Click this link to access the <a href="#">Manage Job Opening Page</a> . Note that if the applicant’s disposition is <i>Draft</i> , the applicant will not appear on the Manage Job Opening page: Applicants tab.
<b>Disposition</b>	Displays the applicant’s current disposition for this job opening (or application without a job opening).

<b>Field or Control</b>	<b>Description</b>
 <b>Resume</b>	<p>Click to open a new window that displays the applicant's resume.</p> <ul style="list-style-type: none"> <li>• If the resume is an attachment, the file opens in the new window.</li> <li>• If the resume was entered into the <b>Resume Text</b> field in the application, the new window displays the <a href="#">Applicant Resume Page</a>.</li> <li>• If no resume exists for a particular applicant, then this column is blank.</li> </ul> <p>If none of the applicants in the grid have resumes, the entire Resume column is hidden.</p>
 <b>Interest</b>	<p>This column appears only if the <b>Display Interest Indicator</b> field on the <a href="#">Recruiting Installation – Applicants Page</a> is set to <i>Yes</i>.</p> <p>Click the first, second, or third star on the interest widget to indicate the level of interest in this applicant for the specified job opening. The stars up to and including the one you click change to solid yellow to provide a visual indication of your interest level.</p> <p>Click the <i>x</i> to clear the rating. All three stars turn gray.</p> <p>The interest level for an applicant is specific to the job opening. It is not, however, user-specific, so your selection is global and can be seen and changed by other users.</p>
 <b>Mark Reviewed</b>	<p>Click to update the applicant's disposition to <i>020 - Reviewed</i>. Because this action always uses the disposition with status code 020, you should not modify this delivered disposition.</p>
 <b>Route</b>	<p>Click to perform the Route Applicant action.</p> <p>If the applicant has at least one existing routing for this job opening, this action displays the <a href="#">Manage Routings Page</a>. If the applicant does not yet have any routings, this action displays the <a href="#">Route Applicant Page</a>.</p>

<b>Field or Control</b>	<b>Description</b>
 <b>Interview</b>	Click to perform the Manage Interviews action.  If the applicant has at least one existing interview for this job opening, , this action displays the <a href="#">Manage Interviews Page</a> . If the applicant does not yet have any interviews, this action displays the <a href="#">Interview Schedule Page</a> .
 <b>Reject</b>	Click to perform the Reject Applicant action, which displays the <a href="#">Reject Applicant Page</a> .
 <b>Print</b>	Click to access the <a href="#">Application Report Options Page</a> , where you can choose report parameters and then generate an application details report.

<b>Field or Control</b>	<b>Description</b>
<b>Other Actions</b>	<p>Click to display a menu of actions that you can perform for the applicant shown in the row.</p> <p>Under the Recruiting Actions sub-menu, you can choose these actions:</p> <ul style="list-style-type: none"> <li>• Create Interview Evaluation</li> <li>• Create Salary Package Model</li> </ul> <p>This action is available only to recruiting administrators, and only if PeopleSoft Global Payroll for Australia is installed.</p> <ul style="list-style-type: none"> <li>• Prepare Job Offer</li> <li>• Accept Offer</li> </ul> <p>This action is available only if there is an offer in the default open status.</p> <ul style="list-style-type: none"> <li>• Reject Offer</li> </ul> <p>This action is available only if there is an offer in the default open status.</p> <ul style="list-style-type: none"> <li>• Withdraw Application</li> </ul> <p>This action is available only if disposition <i>130 Withdrawn Application</i> is configured as a successor of the current disposition.</p> <ul style="list-style-type: none"> <li>• Prepare for Hire</li> </ul> <p>This action is available only if the current disposition is <i>071 - Offer Accepted</i>, <i>080 - Ready to Hire</i>, or <i>090 - Hired 120 - Withdrawn</i>.</p> <ul style="list-style-type: none"> <li>• Withdraw from Hire</li> </ul> <p>This action is available only if the current disposition is <i>080 - Ready to Hire</i>.</p> <ul style="list-style-type: none"> <li>• Edit Application Details</li> <li>• Edit Disposition</li> </ul> <p>If a flexible recruiting process governs the job opening, this is available only if the process provides the user with valid transitions from the current disposition.</p> <p>Under the Application Actions sub-menu, you can choose these actions:</p>



<b><i>Field or Control</i></b>	<b><i>Description</i></b>
	<ul style="list-style-type: none"> <li>• Add Applicant Note</li> <li>• Add Applicant to List</li> <li>• Change Applicant Status</li> <li>• Copy Salary Package</li> </ul> <p>This action is available only to recruiting administrators, and only if PeopleSoft Global Payroll for Australia is installed and the applicant's disposition is <i>Hired</i>.</p> <ul style="list-style-type: none"> <li>• Forward Applicant</li> <li>• Link Applicant to Job</li> <li>• Manage Applicant Checklists</li> <li>• Manage Applicant Contracts</li> <li>• Pre-Employment Check</li> <li>• Send Correspondence</li> </ul> <p>See <a href="#">Understanding Actions for Managing Applicants</a>.</p>

## Group Action

<b><i>Field or Control</i></b>	<b><i>Description</i></b>
<b>Select All and Deselect All</b>	Use these links to select or deselect grid rows so that you can perform group actions on the selected rows.

<b>Field or Control</b>	<b>Description</b>
<p><b>Group Action</b></p>	<p>Click to display a menu of group actions that you can perform for the selected applicants. The actions appear under two sub-menus.</p> <p>Under the Recruiting Actions sub-menu, you can choose these actions:</p> <ul style="list-style-type: none"> <li>• Mark Reviewed</li> <li>• Manage Interviews</li> <li>• Reject Applicant</li> <li>• Route Applicant</li> <li>• Withdraw Application</li> <li>• Edit Application Details</li> <li>• Print Applications</li> </ul> <p>Under the Applicant Actions sub-menu, you can choose these actions:</p> <ul style="list-style-type: none"> <li>• Add Applicant to List</li> <li>• Change Applicant Status</li> <li>• Forward Applicant</li> <li>• Link Applicant to Job</li> <li>• Send Correspondence</li> </ul> <hr/> <p><b>Note:</b> The number of rows that can be included in a group action can be limited using the Group Action Limit field on the <a href="#">Recruiting Installation – Applicants Page</a>. If a user attempts to perform a group action when too many rows are selected, the system displays a message informing the user of the limit and stating that only the allowed number of rows will be processed. If the user continues, the system processes the allowed number of rows, starting at the beginning of the list and following the grid sort order. Even if the user cancels, the system deselects all rows after the specified limit, and the user can review which rows will be processed before re-initiating the action with an allowable number of selected rows.</p> <hr/>

## Managing Applications

This topic discusses the Manage Applications page, which provides a central point for managing activity related to a single applicant for a single job opening (or for an application without a job opening).

This Talent Acquisition Manager overview video includes a demonstration of the Manage Application page:

Video: [Talent Acquisition Manager Overview](#)

### Pages Used to Manage Applications

<i>Page Name</i>	<i>Definition Name</i>	<i>Usage</i>
<a href="#">Manage Application Page</a>	HRS_APPLICATION	Review and manage activity related to a single applicant for a single job opening. The following tabs provide details for specific phases of the recruiting process: <ul style="list-style-type: none"> <li>• <a href="#">Manage Application Page: Application and Resume Tab</a></li> <li>• <a href="#">Manage Application Page: Questionnaire Tab</a></li> <li>• <a href="#">Manage Application Page: Notes Tab</a></li> <li>• <a href="#">Manage Application Page: Route Tab</a></li> <li>• <a href="#">Manage Application Page: Interview Tab</a></li> <li>• <a href="#">Manage Application Page: Offer Tab</a></li> <li>• <a href="#">Manage Application Page: Hire Tab</a></li> <li>• <a href="#">Manage Application Page: Other Tab</a></li> </ul>
<a href="#">Edit Final Recommendation Page</a>	HRS_EDIT_FNL_REC	Enter a final recommendation for an applicant who has been interviewed.

### Understanding the Manage Application Page

The Manage Application page provides a unified view of all recruiting activity for an applicant for a single job opening (or an application without a job opening).

The applicant's current disposition appears alongside one-click actions for the most common recruiting actions, and an Other Actions menu provides access to additional actions.

A set of tabs displays detailed information about each recruiting phase that the applicant has gone through. Users can review:

- The job application, resume, and questionnaire results.
- Applicant notes
- Details associated with each recruiting phase: routing details, interview details, offer details, and hiring details.
- Additional related information including applicant checklists, contracts, pre-employment checks, and salary package models.

Data shown on the Manage Application page is read-only, but links provide immediate access to the related transaction pages, where users can make any necessary updates.

### **Flexible Processing and Applicant Actions**

A job opening's flexible recruiting process (if any) defines appropriate actions based on a user's role and an applicant's current disposition. If the flexible recruiting process disallows a particular action, the Manage Application page does not display the icons or menu commands that would be used to perform the action. Hiding the irrelevant actions helps users to focus on the appropriate next steps in the recruiting process.

The following actions can be hidden by a flexible recruiting process: rejecting, routing, managing interviews, creating interview evaluations, preparing job offers, accepting or rejecting job offers, performing pre-employment checks, preparing for hire, withdrawing from hire, and managing applicant contracts. Additionally, the Edit Disposition action is hidden if the flexible recruiting process does not provide the user with any valid disposition transitions.

## **Manage Application Page**

Use the Manage Application page (HRS\_APPLICATION) to review and manage activity related to a single applicant for a single job opening.

Navigation:

Click the Manage Application icon on any of these pages:

- Manage Job Opening page
- Manage Applicant page
- Search Applications page
- Recruiting Home page: My Applicants pagelet

This example illustrates the Manage Application page.

**Manage Application**

[Return](#) | [Recruiting Home](#) | [Search Applications](#) | [Previous](#) | [Next](#) | [Add Applicant Note](#) | [Print](#) | [Refresh](#)
[Personalize](#)

Applicant	Job Opening
Name: <a href="#">Allan Kirschbaum</a> Applicant ID: 500263 Applicant Type: External Applicant Status: 010 Active Jobs Applied: 1	Job Opening ID: 504001 Job Posting Title: General Office Clerk Job Code: 170005 (Assistant-Administrative) Recruiter: Betty Locherty Hiring Manager: Ponciano Batalang Salary Range: 33,372.00 to 50,058.00 USD/Year
Preferred Contact: Not Specified Phone: 266/795-8640 Email: allan.kirschbaum@oracle... Address:	Status: Open Business Unit: GBIBU (Global Business Institute BU) Department: 10000 (Human Resources) Job Type: Standard Position Number: 19000018 (Administrative Assistant) Job Family: KADMIN (Administrative Support)

**Process Application**

Disposition: 080 Ready to Hire  
 Reason: Interest ★★★★★  
 Date: 01/03/2014

[Mark Reviewed](#) | [Route](#) | [Interview](#) | [Reject](#) | [Other Actions](#)

**Application and Resume** | [Questionnaire](#) | [Notes](#) | [Route](#) | [Interview](#) | [Offer](#) | [Hire](#) | [Other](#)

Personal Information	Attachments										
POI Type: Unknown Eligible to Work in U.S. Are you a former employee Previous Termination Date	<table border="1" style="width: 100%; border-collapse: collapse;"> <thead> <tr> <th>File Name</th> <th>Description</th> <th>Attachment Type</th> <th>Uploaded By</th> <th>Last Updated</th> </tr> </thead> <tbody> <tr> <td>Copy and Pasted Resume</td> <td>Allan Kirschbaum Resume</td> <td>Resume attachments</td> <td>Betty Locherty</td> <td>01/03/2014 1:54PM</td> </tr> </tbody> </table>	File Name	Description	Attachment Type	Uploaded By	Last Updated	Copy and Pasted Resume	Allan Kirschbaum Resume	Resume attachments	Betty Locherty	01/03/2014 1:54PM
File Name	Description	Attachment Type	Uploaded By	Last Updated							
Copy and Pasted Resume	Allan Kirschbaum Resume	Resume attachments	Betty Locherty	01/03/2014 1:54PM							

**Preferences**

Desired Start Date

**Work Experience**

No Work Experience has been added to this applicant's profile.

### Toolbar

<b>Field or Control</b>	<b>Description</b>
<b>Return</b>	Click to return to the previous page.
<b>Recruiting Home</b>	Click to access the <a href="#">Recruiting Home Page</a> .
<b>Search Applications</b>	Click to access the <a href="#">Search Applications Page</a> .
<b>Previous and Next</b>	<p>If you accessed this page from a list showing multiple applications, use these buttons to access other applications in the original list.</p> <p>For example, if you accessed this page from the list of applicants on the Manage Job Opening page: Applicant Activity tab, use these buttons to access additional applicants for the same job opening.</p>
<b>Add Applicant Note</b>	Click to create a new applicant note on the <a href="#">Applicant Notes Page</a> .
<b>Print</b>	Click to access the <a href="#">Application Report Options Page</a> , where you can choose report parameters and then generate an application details report.
<b>Refresh</b>	Click to update the data on this page.

## Applicant

The **Applicant** section of the page displays identifying information about the applicant along with useful information such as the applicant type, applicant status, the number of jobs that the applicant has applied for, and the applicant’s primary contact information.

<i>Field or Control</i>	<i>Description</i>
<b>Name</b>	Click to access the <a href="#">Manage Applicant Page</a> .
<b>Email</b>	If an email address exists, click the email address to access the <a href="#">Send Correspondence Page</a> to send email (or a letter) to the applicant. If a user does not have authorization for the Send Correspondence component, the user’s default email client is opened instead.

## Job Opening

The **Job Opening** section of the page displays identifying information about the job opening along with useful information such as the primary hiring manager and primary recruiter. Click the job posting title to access the [Manage Job Opening Page](#).

System-wide configuration options such as the template segmenting type and the position management option can affect which job opening fields appear. For example, the Position Number field is hidden if you do not use position management.

When you access this page for an application without a job opening, the entire Job Opening section is hidden.

## Process Application

<i>Field or Control</i>	<i>Description</i>
<b>Disposition</b>	Displays the applicant’s current disposition for the job opening.
<b>Reason</b>	Displays the reason, if any, that was supplied when the current disposition was assigned.
<b>Date</b>	Displays the date that the current disposition was assigned.

<b>Field or Control</b>	<b>Description</b>
 <b>Interest</b>	<p>The interest indicator appears only if the <b>Display Interest Indicator</b> field on the <a href="#">Recruiting Installation – Applicants Page</a> is set to <i>Yes</i>.</p> <p>Click the first, second, or third star to indicate the level of interest in this applicant for the current job opening. The stars up to and including the one you click change to solid yellow to provide a visual indication of your interest level.</p> <p>Click the <i>x</i> to clear the rating. All three stars turn gray.</p> <p>The interest level for an applicant is specific to the job opening (or application without a job opening), but it is not specific to the user. Interest level is available as a search field on the <a href="#">Search Applications Page</a>, where it also appears in the search results grid.</p>
 <b>Mark Reviewed</b>	<p>Click to update the applicant’s disposition to <i>020 - Reviewed</i>. Because this action always uses the disposition with status code 020, you should not modify this delivered disposition.</p>
 <b>Route</b>	<p>Click to perform the Route Applicant action.</p> <p>If the applicant has at least one existing routing for this job opening, this action displays the <a href="#">Manage Routings Page</a>. If the applicant does not yet have any routings, this action displays the <a href="#">Route Applicant Page</a>.</p>
 <b>Interview</b>	<p>Click to perform the Manage Interviews action.</p> <p>If the applicant has at least one existing interview for this job opening, , this action displays the <a href="#">Manage Interviews Page</a>. If the applicant does not yet have any interviews, this action displays the <a href="#">Interview Schedule Page</a>.</p>
 <b>Reject</b>	<p>Click to perform the Reject Applicant action, which displays the <a href="#">Reject Applicant Page</a>.</p>

<b>Field or Control</b>	<b>Description</b>
<b>Other Actions</b>	<p>Click to display a menu of additional actions that you can perform. The actions appear under two sub-menus.</p> <p>Under the Recruiting Actions sub-menu, you can choose these actions:</p> <ul style="list-style-type: none"> <li>• Create interview Evaluation</li> <li>• Create Salary Package Model</li> </ul> <p>this action is available only to recruiting administrators, and only if PeopleSoft Global Payroll for Australia is installed.</p> <ul style="list-style-type: none"> <li>• Prepare Job Offer</li> <li>• Accept Offer</li> </ul> <p>This action is available only if there is an offer in the default open status.</p> <ul style="list-style-type: none"> <li>• Reject Offer</li> </ul> <p>This action is available only if there is an offer in the default open status.</p> <ul style="list-style-type: none"> <li>• Withdraw Application</li> </ul> <p>This action is available only if disposition <i>130 Withdrawn Application</i> is configured as a successor of the current disposition.</p> <ul style="list-style-type: none"> <li>• Prepare for Hire</li> </ul> <p>This action is available only if the current disposition is <i>071 - Offer Accepted</i>, <i>080 - Ready to Hire</i>, or <i>090 - Hired 120 - Withdrawn</i>.</p> <ul style="list-style-type: none"> <li>• Withdraw from Hire</li> </ul> <p>This action is available only if the current disposition is <i>080 - Ready to Hire</i>.</p> <ul style="list-style-type: none"> <li>• Edit Application Details</li> <li>• Edit Disposition</li> </ul> <p>If a flexible recruiting process governs the job opening, this is available only if the process provides the user with valid transitions from the current disposition.</p> <p>Under the Application Actions sub-menu, you can choose these actions:</p>



<b>Field or Control</b>	<b>Description</b>
	<ul style="list-style-type: none"> <li>• Add Applicant Note</li> <li>• Add Applicant to List</li> <li>• Change Applicant Status</li> <li>• Copy Salary Package</li> </ul> <p>This action is available only to recruiting administrators, and only if PeopleSoft Global Payroll for Australia is installed and the applicant’s disposition is <i>Hired</i>.</p> <ul style="list-style-type: none"> <li>• Forward Applicant</li> <li>• Link Applicant to Job</li> <li>• Manage Applicant Checklists</li> <li>• Manage Applicant Contracts</li> <li>• Pre-Employment Check</li> <li>• Send Correspondence</li> </ul> <p>See <a href="#">Understanding Actions for Managing Applicants</a>.</p>

### Tabs

These tabs display detailed recruiting information. A tab is visible only if the relevant data exists. For example, the Notes tab is visible only if applicant notes exist.

<b>Field or Control</b>	<b>Description</b>
<b>Application and Resume</b>	The <a href="#">Manage Application Page: Application and Resume Tab</a> displays data from the <a href="#">Application Details Page</a> . This is the only tab that is always visible. (If no other tabs are visible, the data appears without a tab.)
<b>Questionnaire</b>	If the job opening includes a questionnaire, the <a href="#">Manage Application Page: Questionnaire Tab</a> displays the questions and the applicant’s answers.
<b>Notes</b>	If any contact notes exists for the applicant, they appear on the <a href="#">Manage Application Page: Notes Tab</a> .
<b>Route</b>	If the applicant has been routed, the routing details appear on the <a href="#">Manage Application Page: Route Tab</a> .

<b>Field or Control</b>	<b>Description</b>
<b>Interview</b>	If the applicant has any scheduled interviews or any interview evaluations, these appear on the <a href="#">Manage Application Page: Interview Tab</a> .
<b>Offer</b>	If the applicant has any offers, they appear on the <a href="#">Manage Application Page: Offer Tab</a>
<b>Hire</b>	If the applicant has been prepared for hire, information from this process appears on the <a href="#">Manage Application Page: Hire Tab</a> .
<b>Other</b>	The <a href="#">Manage Application Page: Other Tab</a> displays summary information about the following types of information: <ul style="list-style-type: none"> <li>• Applicant checklists</li> <li>• Applicant contracts</li> <li>• Applicant salary package models</li> <li>• Pre-employment checking</li> </ul>

## Manage Application Page: Application and Resume Tab

Use the Manage Application page: Application and Resume tab (HRS\_APPLICATION) to review application details.

Navigation:

Access the [Manage Application Page](#). When you access this page, the Application and Resume tab is displayed.

This example illustrates the top part of the Manage Application page: Application and Resume tab. The page can have additional profile-related grids, but they are not illustrated here.

Application and Resume		Questionnaire																															
<b>Personal Information</b> <p>POI Type: Unknown</p> <p>Eligible to Work in U.S.:</p> <p>Are you a former employee: No</p> <p>Previous Termination Date:</p>		<b>Attachments</b> <table border="1"> <thead> <tr> <th>Attachment</th> <th>Attachment Title</th> <th>Attachment Type</th> <th>Apply to All</th> <th>Uploaded By</th> <th>Last Updated</th> </tr> </thead> <tbody> <tr> <td>JKB_Resume.pdf</td> <td>Jessica Butler Resume</td> <td>Resume</td> <td></td> <td>Betty Locherty</td> <td>09/14/2015 3:25PM</td> </tr> <tr> <td>JKB_Cover_Letter_Sales.pdf</td> <td>J Butler Letter for Sales Jobs</td> <td>Cover Letters</td> <td></td> <td>Jessica Butler</td> <td>09/14/2015 3:29PM</td> </tr> <tr> <td>JKB_Transcript.pdf</td> <td>J Butler Transcript</td> <td>Transcripts</td> <td><input checked="" type="checkbox"/></td> <td>Jessica Butler</td> <td>09/14/2015 3:31PM</td> </tr> <tr> <td>JKB_Writing_Sample.pdf</td> <td>Jessica Butler Writing Sample</td> <td></td> <td><input checked="" type="checkbox"/></td> <td>Betty Locherty</td> <td>09/14/2015 3:33PM</td> </tr> </tbody> </table>		Attachment	Attachment Title	Attachment Type	Apply to All	Uploaded By	Last Updated	JKB_Resume.pdf	Jessica Butler Resume	Resume		Betty Locherty	09/14/2015 3:25PM	JKB_Cover_Letter_Sales.pdf	J Butler Letter for Sales Jobs	Cover Letters		Jessica Butler	09/14/2015 3:29PM	JKB_Transcript.pdf	J Butler Transcript	Transcripts	<input checked="" type="checkbox"/>	Jessica Butler	09/14/2015 3:31PM	JKB_Writing_Sample.pdf	Jessica Butler Writing Sample		<input checked="" type="checkbox"/>	Betty Locherty	09/14/2015 3:33PM
Attachment	Attachment Title	Attachment Type	Apply to All	Uploaded By	Last Updated																												
JKB_Resume.pdf	Jessica Butler Resume	Resume		Betty Locherty	09/14/2015 3:25PM																												
JKB_Cover_Letter_Sales.pdf	J Butler Letter for Sales Jobs	Cover Letters		Jessica Butler	09/14/2015 3:29PM																												
JKB_Transcript.pdf	J Butler Transcript	Transcripts	<input checked="" type="checkbox"/>	Jessica Butler	09/14/2015 3:31PM																												
JKB_Writing_Sample.pdf	Jessica Butler Writing Sample		<input checked="" type="checkbox"/>	Betty Locherty	09/14/2015 3:33PM																												
<b>Preferences</b> <p>Desired Start Date:</p> <p>Regular/Temporary: Either</p> <p>Full/Part-Time: Either</p> <p>Willing to Relocate: No</p> <p>Willing to Travel: No</p> <p>Travel Percentage: Never or rarely</p>		<b>Work Experience</b> <p>No Work Experience has been added to this applicant's profile.</p>																															
<b>Geographic Preferences</b> <p>First Choice:</p> <p>Second Choice:</p> <p>Comments:</p>		<b>Education Level</b> <p>Highest Education Level: A-Not Indicated</p>																															
<b>Desired Work Days</b> <p><input checked="" type="checkbox"/> Monday <input checked="" type="checkbox"/> Tuesday <input checked="" type="checkbox"/> Wednesday</p> <p><input checked="" type="checkbox"/> Thursday <input checked="" type="checkbox"/> Friday <input type="checkbox"/> Saturday</p> <p><input type="checkbox"/> Sunday</p>		<b>Training</b> <p>No Training has been added to this applicant's profile.</p>																															
<p>Minimum Pay:</p> <p>Currency Code:</p> <p>Pay Frequency:</p> <p>Desired Shift(s): Not Applicable</p> <p>Desired Hours Per Week: 40.0</p>		<b>Areas of Study</b> <p>No Areas of Study have been added to this applicant's profile.</p>																															
<b>Referral Source</b> <p>No Referral Sources have been added to this applicant's profile.</p>		<b>Competencies</b> <table border="1"> <thead> <tr> <th>Competencies</th> <th>Competency</th> <th>Effective Date</th> <th>Evaluation Type</th> <th>Proficiency</th> </tr> </thead> <tbody> <tr> <td>Abstract thinking</td> <td>0100</td> <td>09/14/2015</td> <td>Self</td> <td>5-Expert</td> </tr> </tbody> </table>		Competencies	Competency	Effective Date	Evaluation Type	Proficiency	Abstract thinking	0100	09/14/2015	Self	5-Expert																				
Competencies	Competency	Effective Date	Evaluation Type	Proficiency																													
Abstract thinking	0100	09/14/2015	Self	5-Expert																													
		<b>Degrees</b> <p>No Degrees have been added to this applicant's profile.</p>																															
		<b>School Education</b> <p>No School Education have been added to this applicant's profile.</p>																															

This tab displays the same data that you see on the [Application Details Page](#), except that:

- The list of job openings and job families that are associated with the application is not shown.
- Resumes and other attachments are listed together in the **Attachments** grid.

The profile-related grids on this page are the same ones that appear on the Application Details page. Unlike job openings, which use templates to control which content types to use, applications show all of the content types in the primary person profile type. For more information, see [Choosing the Primary Person Profile Type for Recruiting](#).

To modify data on this page, use the Edit Application Details action.

## Related Links

PeopleSoft Human Resources Manage Profiles

## Manage Application Page: Questionnaire Tab

Use the Manage Application page: Questionnaire tab (HRS\_APPLICATION) to review the job opening questionnaire and the applicant's answers (if any) to the questions.

---

**Note:** This tab appears only if the job opening includes a questionnaire. It appears regardless of whether the applicant provided answers.

---

Navigation:

Access the [Manage Application Page](#), then click the Questionnaire tab.

This example illustrates the Manage Application page: Questionnaire tab. By default, the Questions scroll area shows one question at a time, but in this example, the View All link has been clicked so that the page displays all questions from the questionnaire.

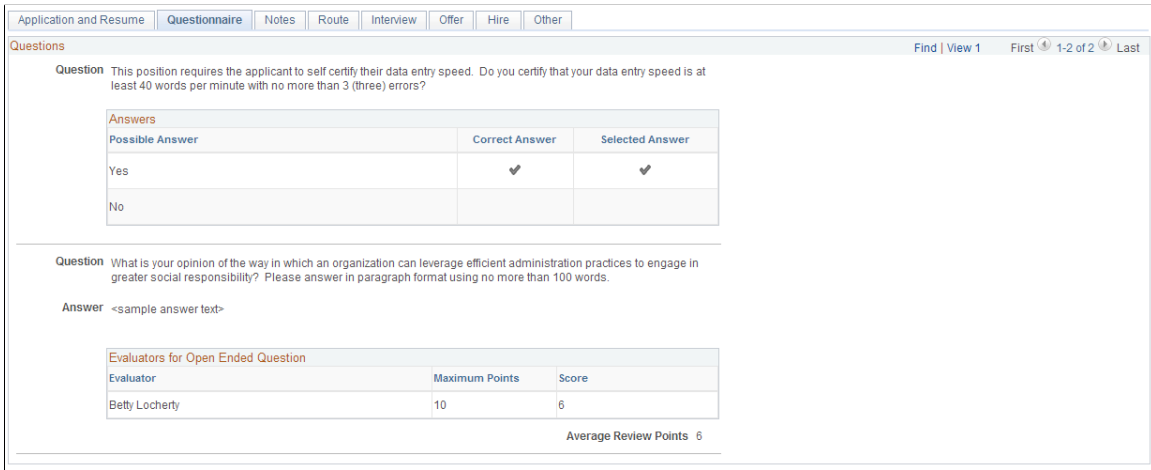

The questions from the questionnaire appear in a scroll area.

For multiple choice questions, the page displays the question and a grid showing all possible answers. Within the grid, check marks in the Correct Answer column identify the correct answers, and check marks in the Selected Answer column indicate the applicant’s answers.

For open-ended questions, the page displays the question, the applicant’s answer, and a grid showing the points assigned by each evaluator.

## Manage Application Page: Notes Tab

Use the Manage Application page: Notes tab (HRS\_APPLICATION) to review applicant notes. Notes are not associated with specific job openings, so all of the applicant’s notes appear (subject to note privacy settings).

---

**Note:** This tab appears only if applicant notes exist.

---

Navigation:

Access the [Manage Application Page](#), then click the Notes tab.

This example illustrates the Manage Application page: Notes tab.

Application and Resume						Questionnaire	Notes	Route	Interview	Offer	Hire	Other	
<b>Notes Summary</b>								Personalize					
Select	Subject						Date Added	Added By					
<input checked="" type="radio"/>	Exchanged emails related to adjusting Brian's start date.							08/31/2017 11:42AM	Betty Locherty				
<input type="radio"/>	Online Job Offer Posted							08/31/2017 11:36AM	Betty Locherty				
<input type="radio"/>	Offer Letter							08/31/2017 11:36AM	Betty Locherty				
<input type="radio"/>	Interview Request							08/31/2017 11:24AM	Betty Locherty				
<b>Note Details</b>								View All					
Subject						Exchanged emails related to adjusting Brian's start date.							
Details						See attached.							
<b>Job Openings</b>						Personalize   View All		1 of 1					
Job Opening ID		Posting Title											
300063		Public Relations Manager-Q											
Author						Betty Locherty							
Contact Method						Outbound Email							
Note Audience						Public							
Contact Date						08/31/2017							
<b>Attachments</b>													
File Name	Description	Date Added	Name										
Adjust_Start_Date_conversation.eml		08/31/2017 11:42AM	Betty Locherty										
Add Applicant Note													

This tab is identical to the Manage Applicant Page: Notes Tab except that you cannot delete notes from this page.

## Manage Application Page: Route Tab

Use the Manage Application page: Route tab (HRS\_APPLICATION) to review applicant routings, including responses from the people to whom the applicant was routed.

**Note:** This tab appears only if the applicant has been routed for this job opening.

Navigation:

Access the Manage Application Page, then click the Route tab.

This example illustrates the Manage Application page: Route tab.

Application and Resume							Questionnaire	Notes	Route	Interview	Offer	Hire	Other
<b>Routing Summary</b>													
Select	Status Date	Route Status		Responses Received	Responses Remaining								
<input type="radio"/>	07/30/2014	010 Route		1	0								
<input checked="" type="radio"/>	07/30/2014	010 Route		2	1								
<b>Routing Details</b>									Edit Routing				
Routing Status							010 Route		Send Reminder				
Reason													
<b>Recipients</b>													
Route Date	Recipient	Assignment	Response Due Date	Response	Response Date	Comments							
07/30/2014	Rosanna Channing	Manager	08/05/2014	020 Invite for Interview									
07/30/2014	Douglas Lewis	Manager	08/05/2014	020 Invite for Interview									
07/30/2014	Jean Parsons	Interviewer	08/05/2014										
Add New Routing													

The Route tab displays the same information that appears on the Manage Routings Page. It also provides the same options for editing routings, sending reminders, and adding new routings.

However, on this tab, the fields in the Routing Status and Reason fields are read-only. To update these fields, click either of the Edit icons to access the Edit Routing page.

## Manage Application Page: Interview Tab

Use the Manage Application page: Interview tab (HRS\_APPLICATION) to review a summary of the applicant’s interviews for this job opening and to enter the final recommendation for the applicant based on the interviews.

---

**Note:** This tab appears only if an interview has been scheduled for this applicant for this job opening.

---

Navigation:

Access the [Manage Application Page](#), then click the Interview tab.

This example illustrates the Manage Application page: Interview tab.

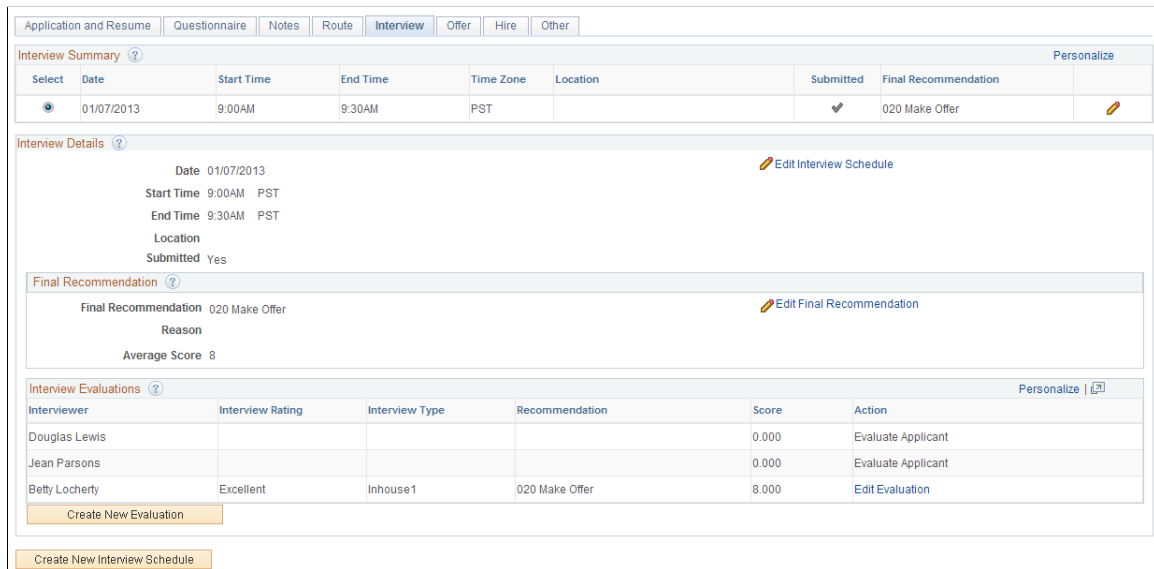

The interview tab displays the same information that appears on the [Manage Interviews Page](#). It also provides the same buttons for creating new interview schedules and new interview evaluations.

However, on this tab, the fields in the Final Recommendation group box are read-only. To update these fields, click the Edit Final Recommendation link to access the Edit Final Recommendation page.

## Edit Final Recommendation Page

Use the Edit Final Recommendation page (HRS\_EDIT\_FNL\_REC) to enter a final recommendation for an applicant who has been interviewed.

Navigation:

Click the **Edit Final Recommendation link on the Manage Application page: Interview tab.**

This example illustrates the Edit Final Recommendation page.

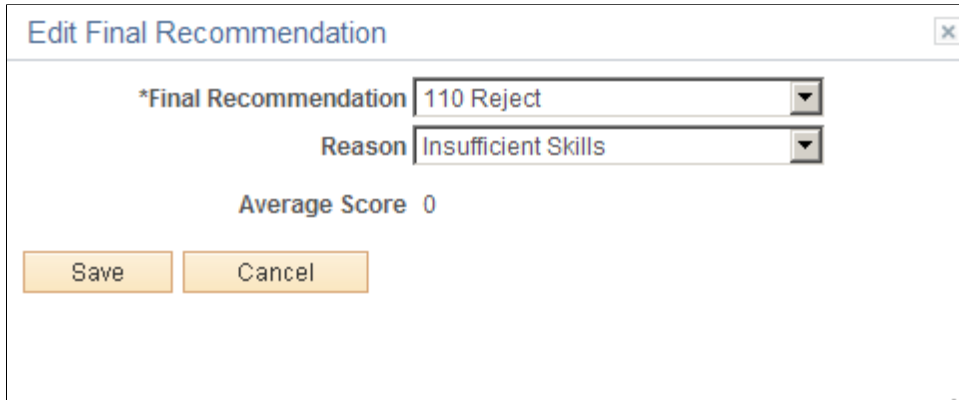

The fields on this page are identical to the fields in the Final Recommendation section of the Manage Interviews Page.

### Manage Application Page: Offer Tab

Use the Manage Application page: Offer tab (HRS\_APPLICATION) to review applicant offers and to accept, reject, or edit the offers.

---

**Note:** This tab appears only if the applicant has an offer for this job opening.

---

Navigation:

Access the Manage Application Page, then click the Offer tab.

This example illustrates the Manage Application page: Offer tab.

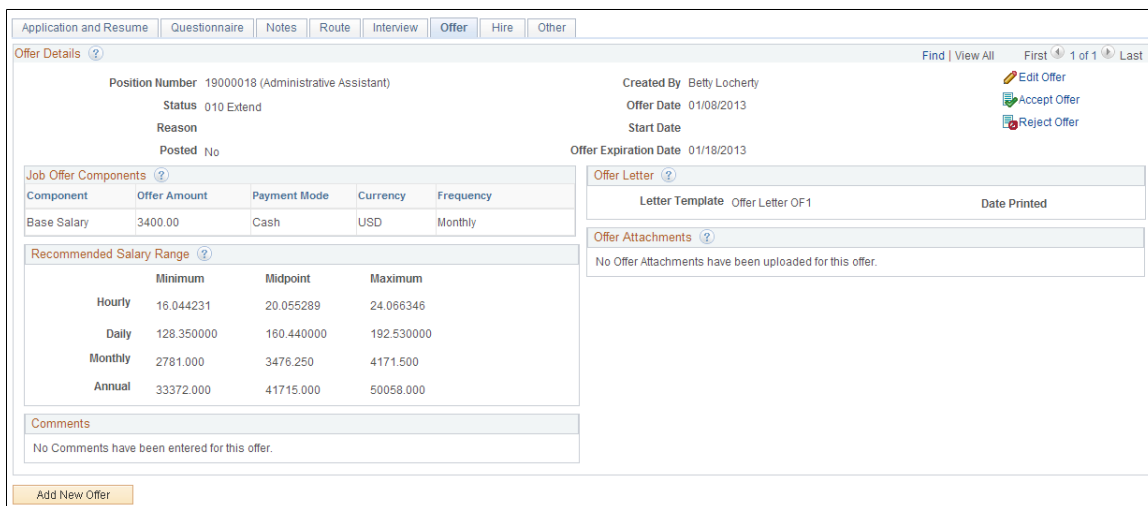

This tab summarizes the offer information from the Prepare Job Offer Page.

To edit the offer, click the **Edit Offer** link. To create a new offer, click the **Add New Offer** button. Both actions open the Prepare Job Offer page.

This tab also provides links for performing the Accept Offer and Reject Offer actions, which are described in the topic [Accepting and Rejecting Offers](#).

If the offer is in a rejected status, this tab provides an **Add Revised Offer** link that works the same as the Add Revised Offer link on the Prepare Job Offer page.

## Manage Application Page: Hire Tab

Use the Manage Application page: Hire tab (HRS\_APPLICATION) to review the information that was included in the hire request for the applicant.

---

**Note:** This tab appears only if the applicant has been prepared for hire for this job opening.

---

Navigation:

Access the [Manage Application Page](#), then click the Hire tab.

This example illustrates the Manage Application page: Hire tab.

Application and Resume		Questionnaire	Notes	Route	Interview	Offer	Hire	Other
Position Number	19000018 (Administrative Assistant)							
Job Code	170005 (Assistant-Administrative)							
Department	10000 (Human Resources)							
Type of Hire	Hire							
Start Date	01/14/2013							
Employee ID	Employee ID not verified							
Send Offer Letter to HR	Yes							
Hire Comments								

This tab summarizes the data on the [Prepare For Hire Page](#).

## Manage Application Page: Other Tab

Use the Manage Application page: Other tab (HRS\_APPLICATION) to review additional applicant data.

---

**Note:** This tab appears only if at least one of the following types of data exist for the applicant: a checklist, a contract, a salary package, or a request for a pre-employment check from a third-party pre-employment vendor. All of these types of data are independent of the job opening.

---

Navigation:

Access the [Manage Application Page](#), then click the Other tab.

This example illustrates the Manage Application page: Other tab.

Application and Resume		Questionnaire	Notes	Route	Interview	Offer	Hire	Other
<b>Supplemental Applicant Information</b>								
Personalize   Find   First 1-3 of 3 Last								
Type	Summary	Status	Date Added	Added By				
Applicant Checklist	Hire	In Progress	02/14/2013	Betty Locherty				
Applicant Contract	0001	Active	02/14/2013	Betty Locherty				
Salary Package Model	1	Proposed	02/14/2013	Betty Locherty				



## Supplemental Applicant Information

This grid displays summary information about any applicant checklists, contracts, salary package models, or pre-employment checks that exist. All four types of data are associated directly to the applicant record, independent of any particular job opening.

<b>Field or Control</b>	<b>Description</b>
<b>Type</b>	Identifies the type of data represented: <i>Applicant Contract</i> , <i>Applicant Checklist</i> , <i>Pre-Employment Check</i> , or <i>Salary Package Model</i> .
<b>Summary</b>	<p>Displays identifying information about the object. Click this link to access the relevant detail page:</p> <ul style="list-style-type: none"> <li>• For applicant checklists, this field displays the checklist description, and clicking the link opens the <a href="#">Applicant Checklist Page</a>.</li> <li>• For applicant contracts, this field displays the contract number, and clicking the link opens the <a href="#">Contract Status/Content Page</a>.</li> <li>• For pre-employment checks, this field displays the name of the background screening provider, and clicking the link opens the <a href="#">Pre-Employment Check Page</a>.</li> <li>• For salary package models, this field displays the model number, and clicking the link opens the applicant salary package pages described in the topic “Modelling Salary Packages for Applicants” (PeopleSoft Human Resources Administer Salary Packaging)</li> </ul>
<b>Status</b>	<p>Displays the status of the related object. Status values depend on the type of object:</p> <ul style="list-style-type: none"> <li>• Applicant checklists are shown as <i>In Progress</i> until all checklist items are marked complete, at which point the status changes to <i>Completed</i>.</li> <li>• Applicant contract statuses are <i>Active</i> or <i>Inactive</i>.</li> <li>• Pre-employment check status are <i>Request Failed</i>, <i>In Progress</i>, or <i>Completed</i>.</li> <li>• Salary package model statuses are <i>Proposed</i>, <i>Confirmed</i>, or <i>Enrolled</i>.</li> </ul>
<b>Date Added</b>	Displays the date that the related object was created

<b>Field or Control</b>	<b>Description</b>
<b>Added By</b>	Displays the name of the person who created the related object.

### Additional Fields for Pre-Employment Checks

These columns are visible only if the Supplemental Applicant Information grid includes a row for a pre-employment check.

<b>Field or Control</b>	<b>Description</b>
<b>Request Number</b>	Displays the request number associated with the pre-employment check request
<b>Adjudication Status</b>	If the <b>Display Adjudication</b> check box is selected on the <a href="#">Pre-Employment Vendor Setup Page</a> Pre-Employment Vendor setup page, this column displays the adjudication status provided by the third-party background screening provider. Otherwise, the value is <i>Not Displayed</i> .

# Screening Applicants

---

## Understanding the Screening Process

Screening is the process used by recruiters to evaluate a list of potential candidates and narrow the list to the most qualified applicants.

This topic discusses the process of running screening. It does not discuss how to set up screening. For information about setting up screening, refer to these topics:

- [Understanding Screening Setup](#)
- [Setting Up Screening Level Definitions](#)
- [Setting Up Screening for a Job Opening](#).

### Process Overview

The standard screening process involves these steps:

1. Review and run screening levels for the job.

You can review both the overall list of screening levels and the detailed screening criteria and processing rules for individual screening levels. You can optionally update the screening level details.

Running a screening level applies the screening level settings and assigns applicants a pass/fail result and an overall score.

2. Review screening results.

Review the pass/fail results, the overall score, and detailed information about how the score was figured. You can also view the applicant data that was used in screening to see if any missing ratings affected the applicant's score.

You can change screening criteria and rerun the screening levels as many times as you like before continuing to the next step.

3. Apply screening results.

When you are satisfied with the results, applying them updates applicant dispositions according to the screening level rules. The system applies results to every applicant who has unapplied screening results. You cannot select individual applicants for this step. Applicants whose results have been applied are not included in any further screening processing.

This diagram illustrates the basic flow for screening applicants.

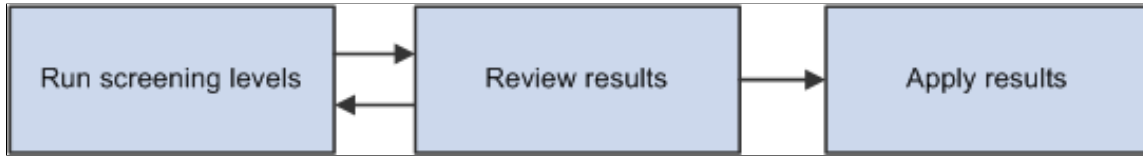

At the conclusion of this process, you are ready to continue to the routing process, where you can seek feedback from others regarding the next recruiting steps for individual applicants.

### **(USF) Extended Process for Federal Users**

The screening process for U.S. federal government jobs involves some additional steps:

1. At the beginning of the process, you run the RS - Priority Placement (HRS\_PRI\_PLCM) Application Engine process to automatically add priority placement applicants to the job opening.

The RS - Priority Placement process adds applicants with a priority placement code and salary grade and level that match the job opening. (The priority placement code by itself is not sufficient.)

2. After you finish running screening levels and applying results, you rank applicants and generate the Certificate of Eligibles.

To accomplish this, you need to:

- a. Assign competitive/non-competitive statuses to applicants.

Applicants without a competitive/non-competitive status are excluded from the ranking process.

- b. Rank applicants according to their cumulative screening scores, augmented by preference items.
- c. Generate a Certificate of Eligibles listing the ranked applicants.

This diagram illustrates additional steps for US federal screening.

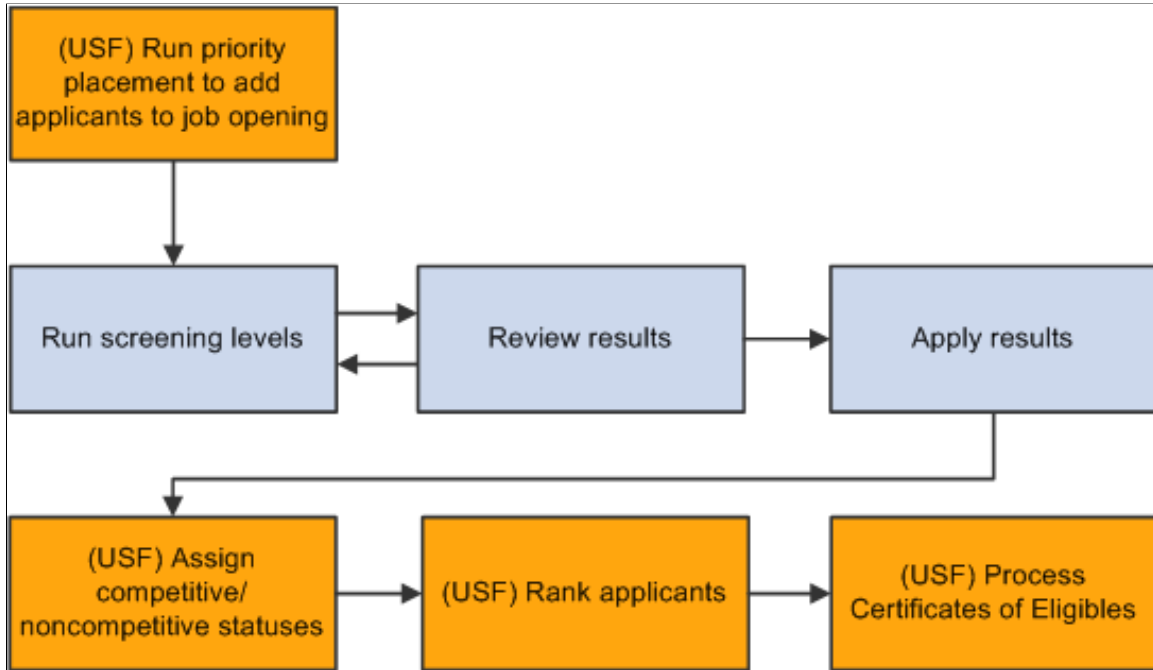

## Evaluating Answers to Open-Ended Screening Questions

This topic provides an overview of open-ended question evaluations and discusses how to enter evaluations.

### Pages Used to Evaluate Open-Ended Questions

<i>Page Name</i>	<i>Definition Name</i>	<i>Usage</i>
<a href="#">Evaluate Open Ended Questions Page</a>	HRS_EVAL_ANS_LST	Review a list of open-ended questions whose answers you have been assigned to evaluate.
<a href="#">Evaluate OE Answers Page</a> (evaluate open ended answers page)	HRS_EVAL_ANS_SEC	Assign scores to answers for open-ended questions.

## Understanding Open-Ended Question Evaluations

When you associate an open-ended question with a job opening, you also assign evaluators for the question.

When the system receives an application with answers to open-ended questions, it sends notifications to the assigned evaluators, advising them of the need to assess the answers. Only the assigned evaluators can award an applicant points for the answer.

During screening, an applicant’s score for an open-ended questions is the average of all submitted evaluations. For example, if a question has three evaluators, and only two evaluators have submitted evaluations, the system averages the scores of those two evaluations and disregards the missing evaluation.

When there are no submitted evaluations, the screening process does not award any points for the question. During screening, if you see that an applicant did not receive any points for an answer, you can review the applicant's questionnaire to ascertain whether the score was due to a lack of evaluations.

Recruiters can use the [My Alerts Pagelet](#) and the [Unevaluated Answers Page](#) to send reminder notifications to evaluators.

## Evaluate Open Ended Questions Page

Use the Evaluate Open Ended Questions page (HRS\_EVAL\_ANS\_LST) to review a list of open-ended questions whose answers you have been assigned to evaluate.

Navigation:

**Self Service > Recruiting > Evaluate Open Ended Questions**

This example illustrates the Evaluate Open Ended Questions page.

### Evaluate Open Ended Questions

Listed Below are answers to open ended questions for applicants for a particular Job Opening. Select the Reference Number on the desired grid row to see the details and provide a score for each applicant that has answered. When an evaluation for an answer is complete, choose the Submit button to release questions for screening. To store assigned score, but not submit questions at this time, choose the Save button.

Answers to be Evaluated		Personalize   Find	
Reference Number	Points Given	Evaluated	Primary Recruiter
<a href="#">30012913002701105</a>		<input type="checkbox"/>	Jake Oglevy
<a href="#">30013113002701105</a>	7	<input type="checkbox"/>	Jake Oglevy
<a href="#">30013113002701105</a>		<input type="checkbox"/>	Jake Oglevy

The Answers to Be Evaluated grid includes a row for each answer that you need to evaluate. After you submit an evaluation, the row disappears from the grid.

<b>Field or Control</b>	<b>Description</b>
<b>Reference Number</b>	<p>To help ensure non-biased evaluation, the system identifies answers to be evaluated using a reference number rather than providing identifying information for the applicant or job opening. The reference number is used in reminder notifications as well as on this page.</p> <p>Click the reference number to access the <a href="#">Evaluate OE Answers Page</a>, where you can award points for the answer.</p>

<b>Field or Control</b>	<b>Description</b>
<b>Points Given</b>	If you entered points on the Evaluate OE Answers page and then saved without submitting, the point value appears in this column. The column is empty for questions where you have not saved a point value.
<b>Evaluated</b>	Displays a deselected check box to indicate that the evaluation is not complete.
<b>Primary Recruiter</b>	Displays the primary recruiter, if any, for the job opening with which the question is associated.

## Evaluate OE Answers Page

Use the Evaluate OE Answers (evaluated open ended answers) page (HRS\_EVAL\_ANS\_SEC) to assign scores to answers for open-ended questions.

Navigation:

Click the **Reference Number** link in the Answers to be Evaluated grid on the Evaluate Open Ended Questions page.

This example illustrates the Evaluate OE Answers page.

**Evaluate OE Answers**

---

**Reference Number** 30012915037081106

**Question**

Please describe (in 500 words or less) how you would regulate organizational environmental policy to attain maximum compliance without unnecessary loss of flexibility?

**Applicant Answer**  
sample text

**Maximum Points** 100
**Total Words** 2
**Enter Evaluation Points**

Save
Submit
Cancel

<b>Field or Control</b>	<b>Description</b>
<b>Reference Number</b>	The system identifies answers to be evaluated using a reference number rather than providing identifying information for the applicant or job opening. This helps ensure non-biased evaluations.

<b>Field or Control</b>	<b>Description</b>
<b>Question</b>	Displays the full text of the question.
<b>Applicant Answer</b>	Displays the applicant's answer to the question.
<b>Maximum Points</b>	Displays the maximum points that the evaluator can award the applicant for this answer.
<b>Total Words</b>	Displays the word count for the answer.
<b>Enter Evaluation Points</b>	Enter the number of points to be awarded to the applicant for this answer. Refer to the Maximum Points value to determine the rating scale for points.
<b>Save</b>	Click to save the evaluation points without submitting the evaluation. Return to the page later to submit a final evaluation. If you enter evaluation points and save without submitting, the points appear on the Evaluate Open Ended Questions page.
Submit	Click to submit evaluation points. Once you submit an evaluation, the answer no longer appears in the Answers to Be Evaluated grid on the Evaluate Open Ended Questions page.
Cancel	Click to return to the Evaluate Open Ended Questions page without saving changes.

## (USF) Running the Priority Placement Process

This topic provides an overview of the priority placement process and discusses how to run the priority placement process.

**Note:** You can also use the [Manage Job Opening Page: Applicant Screening Tab: Screening Level Section](#) to run the priority placement process for a specific job opening.

### Page Used to Run the Priority Placement Process

<b>Page Name</b>	<b>Definition Name</b>	<b>Usage</b>
<a href="#">Process Priority Placement Page</a>	HRS_RUN_PR_PL	Run the RS-Priority Placement process on a selected job opening or on all open job openings.



## Understanding the Priority Placement Process

Applicants with priority placement are entitled to automatic consideration for job openings that meet certain criteria, even if the applicant hasn't specifically applied for the job opening. Use the RS - Priority Placement (HRS\_PRI\_PLCM) Application Engine process to identify those applicants for one or more job openings.

The Priority Placement process identifies applicants that have the same priority placement code, pay plan, and occupational series as the job opening that is being processed. It also ensures that the applicant's Salary Grade is equal to or greater than the grade specified on the job opening.

When an applicant has two priority placement codes for a particular job, and only one priority placement code method can be considered for that job series, the process determines which code to use by looking at the recruiting type (*Internal*, *Merit Promotion*, or *Open Competition*) that was defined on the job opening.

The Priority Placement process links applicants to job openings using the default disposition (as delivered, this is the *Applied* disposition). Once linked to the job opening, the applicant goes through the same screening process as other applicants.

---

**Note:** Run the Priority Placement process after the closing date of the job posting and before running other screening processes.

---

## Process Priority Placement Page

Use the Process Priority Placement page (HRS\_RUN\_PR\_PL) to run the RS-Priority Placement process on one job opening or all open job openings.

Navigation:

**Recruiting > Administration > Process Priority Placement**

This example illustrates the Process Priority Placement page.

<b>Field or Control</b>	<b>Description</b>
<b>All Open Job Openings</b>	Select this check box to run the RS - Priority Placement process on all job openings with an <i>Open</i> status. If you select this check box, the <b>Job Opening ID</b> field is unavailable.

<b>Field or Control</b>	<b>Description</b>
<b>Job Opening ID</b>	If you do not select the <b>All Open Job Openings</b> check box, enter the ID for a single job opening that you want to process.
<b>Run</b>	Click to access the Process Scheduler Request page, where you schedule the process.

## Running Screening Levels and Applying Results

This topic provides an overview of screening level processing and discusses how to run screening levels, review results, and apply results.

### Pages Used to Run and Apply Screening Levels

<b>Page Name</b>	<b>Definition Name</b>	<b>Usage</b>
<a href="#">Manage Job Opening Page: Applicant Screening Tab: Screening Level Section</a>	HRS_JO_SCR_LVL	Review screening levels and run screening processes.
<a href="#">Manage Job Opening Page: Applicant Screening Tab: Screening Results Section</a>	HRS_JO_SCR_LVL	Review and apply screening results.
<a href="#">Screening Details Page</a>	HRS_APP_SCR_RSLT	Review how many total points the applicant earned in the screening level and how many points were awarded for each type of screening criteria.
<a href="#">Questionnaire Results Page</a>	HRS_VIEW_QSTN_RSLT	Review the applicant's answers to the questionnaire that was completed during the online application process.
<a href="#">Rate Applicant Page</a>	HRS_RATE_APP	Review an applicant's points for profile-related screening criteria.
<a href="#">(USF) Set Competitive Status Page</a>	HRS_SCR_MRK_SEC	Assign an applicant's competitive or non-competitive status for US Federal recruiting purposes.

## Understanding Screening Level Processing

This overview discusses how you run screening levels and apply the results.

## Running Screening Levels

You can run standard screening levels using the Manage Job Opening page: Applicant Screening tab. Run screening levels from either one of the two sections on this tab: the Screening Levels section or the Screening Results section.

You cannot run screening levels for prescreening or online screening. For these screening levels, the system evaluates applicants individually during the Candidate Gateway online application process.

If the screening settings on the [Job Opening Page: Applicant Screening Section](#) indicate that applicants must pass the previous level, the system filters out applicants who have not passed the previous screening level before performing any actual screening.

The system also filters out applicants based on their dispositions. Specifically, the system processes only applicants whose dispositions are configured as open statuses associated with either the *1-Applied* phase, the *2-Reviewed* phase, or no phase at all. This prevents applicants in the later phases of the recruiting process (*3-Screen*, *4-Route*, *5-Interview*, *6-Offer*, *7-Hire*, *8-Hold*, or *9-Reject*) from being processed.

When you run a screening level, the RS-Job Opening Screening (HRS\_JO\_SCR) Application Engine process uses the settings on the [Job Opening - Screening Criteria Page](#) as it performs the following tasks for each included applicant:

1. Evaluates whether the applicant has the attributes that you have selected as screening criteria.
2. Awards the specified number of points for each screening criterion that the applicant meets.

In U.S. federal implementations, the system keeps track of which attributes are marked as **Augment** or **Selective** so that the point subtotals for those types of criteria are available to use during the ranking process.

3. Adds the points earned for individual items to produce a cumulative point total.

This value represents the applicant's raw points for the screening level.

4. Evaluates whether the applicant passes or fails the screening level.

Applicant can fail a screening level if they have not earned enough points or if they do not meet criteria that was designated as required.

Screening levels can be configured to allow users with access to the screening pages to manually override the pass/fail status that the system assigns.

5. Assigns the applicant a final overall score for the screening levels.

Depending on the screening rules, the overall score might be the same as the raw points.

U.S. federal screening processes, however, use other scoring methods such as fixed scores for passing or failing or transmutation to a predetermined maximum based on the proportion of points earned to total available points.

This diagram illustrates the process flow for the RS - Job Opening Screening process:

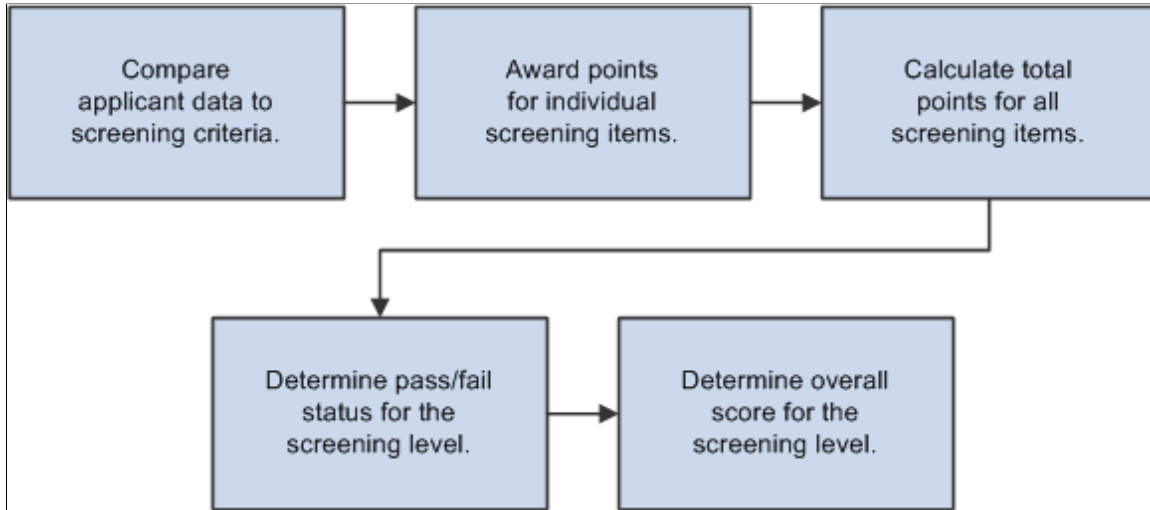

## Reviewing and Applying Screening Results

After running a screening level, use the [Manage Job Opening Page: Applicant Screening Tab: Screening Results Section](#) to review the results. If you are satisfied, you can finalize those results by clicking **Apply Results** button.

When you apply results, the system performs these actions:

- Updates the applicants' dispositions according to the settings in the screening level definition.

When you review screening results, you can see the disposition that will be applied. There are separate settings for applicants who pass and who fail the screening level.

- Creates rejection letters for applicants who fail the screening level.

This occurs only if the screening level criteria identifies a letter to send. Depending on the screening level settings, the letter is either sent as an email or it is added to the queue for the HRS Letter Generation (HRSLETTR) Application Engine process. To run the HRS Letter Generation process, use the [Generate Recruitment Letters Page](#).

- Updates the applicant data to show that the screening results have been applied.

Results are applied for every applicant who has screening results. If an applicant has results for multiple screening levels, the system uses the disposition settings and rejection letter settings from the last screening level.

Once results are applied for an application, that application is excluded from any subsequent runs of the screening level process. Therefore, after you apply results, the only reason to run the screening process again is if new applications have been linked to the job opening. Note that results are applied to an application rather than to an applicant, so if an applicant submits another additional application after results have been applied to an earlier application, the new application is included in the screening process.

---

**Note:** Even after results are applied, you can continue to screen applicants who are subsequently added to the job opening.

---

## Prerequisites

There are two types of prerequisites for screening processing.

First, there are implementation tasks, including:

1. (USF) Defining veteran preference codes.
2. (USF) Defining priority placement codes.
3. Creating screening level definitions.
4. Creating screening templates and linking them to recruitment templates.

Then, at runtime, you need to add job-specific screening criteria to each screening level that will be used.

This process involves selecting specific qualifications, questions, and job attributes to look at when assessing applicants. When you define screening criteria for a job opening, you can also review and override default settings from screening level definitions.

### Related Links

[Job Opening - Screening Criteria Page](#)

## Manage Job Opening Page: Applicant Screening Tab: Screening Level Section

Use the Manage Job Opening Page: Applicant Screening tab: Screening Level section (HRS\_JO\_SCR\_LVL) to review screening levels and run screening processes.

---

**Note:** The Applicant Screening tab is visible only if the job opening has at least one standard screening level (a screening level that is not for prescreening or online screening). If a standard screening level is present, the tab is visible even if no screening criteria exists.

---

Navigation:

**Recruiting > Search Job Openings**

Click a job opening link in the search results, and access the Applicant Screening tab.

This example illustrates the Manage Job Opening page: Applicant Screening tab: Screening Level section.

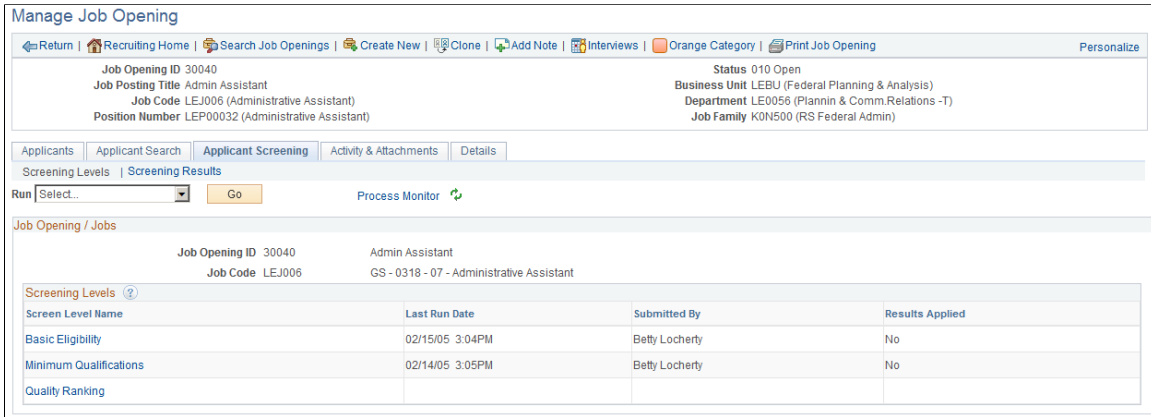

**Note:** For information about the parts of this page that are not under the Applicant Screening tab, refer to the documentation for the [Manage Job Opening Page](#).

### Running a Screening Level

<b>Field or Control</b>	<b>Description</b>
<b>Run</b>	Select a screening level to run. In US Federal implementations, you can also select <i>Priority Placement</i> to run the priority placement process.  See <a href="#">(USF) Running the Priority Placement Process..</a>
<b>Go</b>	Click to run the screening level (or priority placement process) that you selected in the <b>Run</b> field.  If the job opening includes multiple job codes, the screening level processes all job codes for which criteria has been defined.  <b>Note:</b> Run the Priority Placement process after the closing date of the job posting and before running other screening processes..
<b>Process Monitor</b>	Click to access the Process Monitor page, where you can monitor the progress of the screening process. Screening uses the HRS_JO_SCR Application Engine process. Priority Placement uses the HRS_PRI_PLCM Application Engine process.

<b>Field or Control</b>	<b>Description</b>
	<p>Click the <b>Refresh</b> icon to show the latest screening results after you run a screening process. The results are not available until the screening process finishes. After refreshing, check the date and time in the <b>Last Run Date</b> field of the Screening Levels grid to see whether the process is complete.</p> <p>To view the results of a screening process or priority placement process, click the Screening Results link and review the Applicants grid for the process.</p>

## Job Opening / Jobs

This scroll area displays information about the job opening. If there are multiple jobs associated with the job opening, you can scroll to see each one. Multiple rows are possible only if the **Allow Multiple Jobs/Positions** field on the [Recruiting Installation – Jobs Page](#) is set to *Yes*.

## Screening Levels

<b>Field or Control</b>	<b>Description</b>
<b>Screen Level Name</b>	<p>Identifies the screening level. Click the link to access the <a href="#">Job Opening - Screening Criteria Page</a>, where you can review and update the screening configuration.</p> <p>If the screening level is for prescreening or online screening, the screening level name is not a link. To view or update criteria for prescreening or online screening, access the Job Opening - Screening Criteria page from the Manage Job Opening page: Details tab or, if results exist, from the Screening Results section on the Applicant Screening tab.</p>
<b>Last Run Date</b>	For standard screening levels, this column displays the date and time that the screening level last ran. This column is blank for prescreening and online screening.
<b>Submitted By</b>	For standard screening levels, this column displays the name of the user who most recently ran the screening level. This column is blank for prescreening and online screening.

<b>Field or Control</b>	<b>Description</b>
<b>Results Applied</b>	<p>For screening levels that have run at least once, this field displays <i>Yes</i> or <i>No</i> to indicate whether the screening results have been applied. The field is blank for screening levels that you have not yet run.</p> <p>Prescreening and online screening results are always applied immediately, so this field always displays <i>Yes</i> for these screening levels.</p>

## Manage Job Opening Page: Applicant Screening Tab: Screening Results Section

Use the Manage Job Opening Page: Applicant Screening tab: Screening Results section (HRS\_JO\_SCR\_LVL) to review and apply screening results.

**Note:** The Applicant Screening tab is visible only if the user has security access to the screening pages and if the job opening has at least one standard screening level (a screening level that is not for prescreening or online screening).

Navigation:

**Recruiting > Search Job Openings**

Click a job opening link in the search results, and access the Applicant Screening tab: Screening Results section.

This example illustrates the Manage Job Opening page: Applicant Screening tab: Screening Results section

The screenshot displays the 'Manage Job Opening' interface. At the top, it shows job details for Job Opening ID 30040, Job Posting Title Admin Assistant, Job Code LEJ006, and Position Number LEP00032. The status is '010 Open' and the business unit is 'LEBU (Federal Planning & Analysis)'. Below this, there are navigation tabs for Applicants, Applicant Search, Applicant Screening (selected), Activity & Attachments, and Details. The 'Screening Levels' section shows a table with columns for Select, Job Code, Job Code Name, Primary Job Screening Level, Last Run Date, Applicants Screened, Applicants Passed, Applicants Failed, Unapplied Results, and Submitted By. Two screening levels are listed: '1-Basic Eligibility' and '2-Minimum Qualifications'. Below this is the 'Applicants' section with a table showing columns for Select, Score, Points, Applicant Name, Applicant ID, Disposition, Screening Result, Results Applied, Competitive Status, Status Date, Applicant Type, Route, and View Rating. Three applicants are listed: Jose Campos (100%), Deborah Diba (100%), and Kerry O'Reilly (67%). At the bottom, there are buttons for 'Select All', 'Deselect All', 'Route', 'Merge', and 'Set Competitive Status'.

**Note:** For information about the parts of this page that are not under the Applicant Screening tab, refer to the documentation for the [Manage Job Opening Page](#).



## Running a Screening Level

<i>Field or Control</i>	<i>Description</i>
<b>Run</b>	<p>Select a screening level to run. In US Federal implementations, you can also select <i>Priority Placement</i> to run the priority placement process.</p> <p>See <a href="#">(USF) Running the Priority Placement Process</a>.</p>
<b>Go</b>	<p>Click to run the screening level (or priority placement process) that you selected in the <b>Run</b> field.</p> <p>If the job opening includes multiple job codes, the screening level processes all job codes for which criteria has been defined.</p>
<b>Process Monitor</b>	<p>Click to access the Process Monitor page, where you can see whether the screening process has finished. On the Process Monitor page, the screening process is the HRS_JO_SCR Application Engine process, and the Priority Placement process is the HRS_PRI_PLCM Application Engine process.</p>
	<p>Click the <b>Refresh</b> icon to show the latest screening results after you run a screening process. The results are not available until the screening process finishes. Use the Process Monitor page to see if a screening process is complete, or look at the date and time in the <b>Last Run Date</b> field of the Screening Levels grid to see whether the page is showing results from your most recent screening processing.</p>

## Applying Results and Ranking Applicants

<i>Field or Control</i>	<i>Description</i>
<b>Apply Results</b>	<p>Click to apply the most recent screening results. When you apply results, the system updates the applicants' dispositions according to the settings in the screening level definition.</p> <p>If an applicant has unapplied results for more than one screening level, the system updates the applicant's disposition based on the results of the last screening level in the ordered list of screening levels.</p>
<b>(USF) Rank Applicants</b>	<p>Click to access the <a href="#">Rank Applicants Page</a>, where you rank applicants for US federal recruiting purposes.</p>

## Screening Levels

This grid provides summary information about screening levels that have run at least once.

<b>Field or Control</b>	<b>Description</b>
<b>Select</b>	Select a screening level whose details results you want to see. The page updates the <b>Applicants</b> grid to show results for the selected screening level.
<b>Job Code and Job Code Name</b>	These fields identify the job code for the screening level. If the job opening has only one job code, the values are the same for all screening levels. But if the job opening has multiple job codes, each job code can have different screening settings.
 <b>Primary Job</b>	Displays the <b>Primary Job</b> icon if the job code is the primary one for the job opening. If the job opening has only one job code, the icon appears in all rows.
<b>Screening Level</b>	Displays the screening level name. If a job opening has multiple job codes that use a particular screening level, then the screening level appears in multiple rows in this grid. In this situation, use the job code information to distinguish the rows.  Click the screening level name link to access the <a href="#">Job Opening - Screening Criteria Page</a> , where you can review and optionally update the screening level configuration.
<b>Last Run Date</b>	For standard screening levels, this column displays the date and time that the screening level last ran. This column is blank for prescreening and online screening.
<b>Applicants Screened</b>	Displays the total number of applicants who have been screened using this screening level.
<b>Applicants Passed</b>	Displays the total number of applicants who passed this screening level.
<b>Applicants Failed</b>	Displays the total number of applicants who failed this screening level.
<b>Unapplied Results</b>	Displays the number of applicants who were processed but whose results have not been applied.



<b>Field or Control</b>	<b>Description</b>
<b>Submitted By</b>	Displays the name of the person who most recently ran this screening level.

## Applicants

This grid lists the detailed results for applicants who were processed by the screening level that is selected in the Screening Levels grid.

**Note:** When running a screening level, the system processes only applicants whose dispositions are configured as open statuses associated with either the *1-Applied* phase, the *2-Reviewed* phase, or no phase at all. Additionally, if the **Must Pass Previous Levels** check box is selected for the job opening/job code, the screening process does not include applicants who have not passed the previous screening levels.

<b>Field or Control</b>	<b>Description</b>
<b>Select</b>	Select applicants to include when you use the Route, Merge, or Set Competitive Status buttons on this page. <hr/> <b>Note:</b> Selection does not affect which applicants are included when you run a screening level. <hr/>
<b>Score</b>	Displays the percent of the maximum possible score that the applicant earned. Click the link to access the <a href="#">Screening Details Page</a> , where you can see how many points the applicant earned for various types of screening criteria.
<b>Points</b>	Displays the overall screening points that the applicant earned for the screening level. Depending on the screening level configuration, this could be the raw points that the applicant earned, or it could be a fixed number that is associated with a pass or fail status.
<b>Applicant Name and Applicant ID</b>	These fields display identifying information about the applicant. Click an applicant's name to access the <a href="#">Manage Applicant Page</a> .
<b>Disposition</b>	Displays the disposition that will be assigned when results are applied (not the applicant's current disposition). This disposition is based on the screening settings and whether the applicant passed or failed the screening level.

<b>Field or Control</b>	<b>Description</b>
<b>Screening Result</b>	<p>Displays <i>Passed</i> or <i>Failed</i>.</p> <p>If the <b>Manually Assign Status</b> check box is selected on the Job Opening - Screening Criteria page, then you can change the status. Otherwise, this field is read-only.</p>
<b>Results Applied</b>	<p>Displays <i>Yes</i> if results have been applied to all screened applicants, <i>No</i> if results have not been applied to any applicants, or <i>Partial</i> if results have been applied to some (but not all) applicants.</p> <p>Keep in mind that when you apply results, the results are applied to all applicants who have been screened. Therefore, a value of <i>Partial</i> appears only if additional applicants have been screened since results were last applied.</p> <p>After you apply results, you cannot reprocess the same applicants.</p>
<b>(USF) Competitive Status</b>	<p>In US federal installations, this field displays the competitive status that you assign to the applicant: <i>Competitive</i>, <i>Non-Competitive Other</i>, or <i>Noncompetitive VRA</i> (noncompetitive veterans recruitment appointment). The field is blank for applicants whose competitive status hasn't been assigned.</p> <p>To assign a status, select the check box for one or more rows in the Applicants grid and click the <b>Set Competitive Status</b> button.</p>
<b>Status Date</b>	<p>Displays the date that the applicant's pass or fail status was determined.</p>
<b>Applicant Type</b>	<p>Displays the applicant type: <i>External Applicant</i>, <i>Employee</i>, or <i>Non Employee</i>.</p>
 <b>Route</b>	<p>Click to route the applicant. The <a href="#">Route Applicant Page</a> appears.</p>
 <b>View Rating</b>	<p>Click to access the <a href="#">Rate Applicant Page</a>, where you can review an applicant's points for profile-related screening criteria.</p>

## Buttons for Performing Applicant Actions

<i>Field or Control</i>	<i>Description</i>
<b>Select All</b> and <b>Deselect All</b>	Use these links to select or deselect grid rows so that you can perform group actions on the selected rows.
<b>Route</b>	Click to route all of the selected applicants. The <a href="#">Route Applicant Page</a> appears.
<b>Merge</b>	Click to access the <a href="#">Review Duplicate Applicants Page</a> , where the selected applicants appear as a set of duplicates for you to review and optionally merge.
<b>(USF) Set Competitive Status</b>	Click to access the <a href="#">(USF) Set Competitive Status Page</a> so that you can assign each applicant a competitive status.

## Screening Details Page

Use the Screening Details page (HRS\_APP\_SCR\_RSLT) to review how many total points the applicant earned in the screening level and how many points were awarded for each type of screening criteria.

Navigation:

Click a **Score** link in the Applicants grid on the Manage Job Opening Page: Applicant Screening Tab: Screening Results section.

This example illustrates the Screening Details page.

[Screen Applicants](#)

## Screening Details

Karla Beneffer

Applicant ID 300129

---

[Return to Previous Page](#)

---

**Job/Job Opening Summary** [Find](#) | [View All](#)    First ◀ 1 of 1 ▶ Last

Job Opening ID 500411	Systems Analyst
Job Code 140080	Analyst-Systems

**Screening Level Summary** [Find](#) | [View All](#)    First ◀ 1 of 2 ▶ Last

Screening Level	Preliminary	
Screening Points	70.0	Level Score 70.0
Screening Status	Passed	Status Date 02/02/2013
Status Reason		

**Level Points Detail**

General Requirements	50	Augmentation Points	0.0
Education/Experience	0	Selective Factor Points	0.0
JPM Content Score	0	Veterans Preference Points	0
Screening Questions	20	<a href="#">View Questionnaire Results</a>	

---

[Return to Previous Page](#)

### Job/Job Opening Summary

This section has one row for each job code in the job opening. Multiple rows are possible only if the **Allow Multiple Jobs/Positions** field on the Recruiting Installation – Jobs Page is set to *Yes*.

### Screening Level Summary

This section has one row for each screening level that you've run for the applicant.

<b>Field or Control</b>	<b>Description</b>
<b>Screening Level</b>	Identifies the screening level whose results you are examining. Scroll to see results for other screening levels.
<b>Screening Points</b>	Displays the raw points that the applicant earned for the screening level.
<b>Level Score</b>	Displays the applicants overall score for the screening level. For example, if a screening level awards 70 points for passing, this field displays 70.  If the screening level uses raw points, this is the same as the Screening Points field.
<b>Screening Status</b>	Indicates whether the applicant <i>Passed</i> or <i>Failed</i> the screening level.
<b>Status Date</b>	Displays the most recent date that the applicant was screened with this screening level.
<b>Status Reason</b>	If the applicant failed the screening level, this field displays an explanation such as <i>Applicant failed minimum screening level percent requirement</i> .

## Level Points Detail

This group box breaks down the sources of the applicant's raw points.

<b>Field or Control</b>	<b>Description</b>
<b>General Requirements</b>	Displays the number of points that the applicant received for meeting General Information screening criteria. This includes criteria from the Job Information and Salary Information sections of the job opening.
<b>Education/Experience</b>	Displays the number of points that the applicant received for meeting Education & Experience screening criteria. This refers specifically to the Education & Experience section of the job opening and does not include any profile-based education criteria.

<b>Field or Control</b>	<b>Description</b>
<b>JPM Content Score</b> (job profile management content score)	Displays the number of points that the system awarded to the applicant based on profile content type qualifications such as competencies, languages, and degrees.
<b>Screening Questions</b>	<p>Display the number of points that the system awarded based on the applicant's responses to screening questions.</p> <hr/> <p><b>Note:</b> The system does not award any points for unanswered questions or for open-ended questions that have been answered but not yet evaluated. Click the View Questionnaire Results link to ascertain whether either of these conditions is true and whether you need to send reminders to applicants or evaluators.</p> <hr/>
<b>View Questionnaire Results</b>	Click to access the Questionnaire Results page, where you can view the applicant's responses to screening questions.

### (USF) Additional Federal Screening Data

These fields in the Level Points Detail group box appear only in federal systems.

<b>Field or Control</b>	<b>Description</b>
<b>(USF) Augmentation Points</b>	<p>Displays the number of points that the applicant received for screening items that were marked as <b>Augment</b> on the Job Opening - Screening Criteria page.</p> <p>These are included in the total point for the screening level.</p>
<b>(USF) Selective Factor Points</b>	<p>Displays the number of points that the applicant received for screening items that were marked as <b>Selective</b> on the Job Opening - Screening Criteria page.</p> <p>These are included in the total point for the screening level.</p>
<b>(USF) Veterans Preference Points</b>	<p>Displays the number of veterans preference points that the system awards based on the applicant's veterans preference code.</p> <p>These points are not associated with any particular screening level, so although they are displayed in the summary for each screening level, they are <i>not</i> included in the total points for the screening level. They are added to the applicant's cumulative screening score on the Rank Applicants page.</p>



## Questionnaire Results Page

Use the Questionnaire Results page (HRS\_VIEW\_QSTN\_RSLT) to review the applicant's answers to the questionnaire that was completed during the online application process.

Navigation:

Click the **View Questionnaire Results** link on the Screening Details page.

This example illustrates the Questionnaire Results page.

[Screen Applicants](#)

### Questionnaire Results

Karla Beneffer

Applicant ID 300129

Screening Level    Preliminary

---

[Return to Previous Page](#)

---

**CORRECT**      This position is only available only to candidates who are 25 or older. Do you self certify that you are 25 years of age or older?

Screening Questions		
<input checked="" type="checkbox"/>	Yes	10
<input type="checkbox"/>	No	

**CORRECT**      This position requires someone who can certify that they are in a position to be absent from their home for a consecutive period of 12 months.

Are you able to self certify that you can absent yourself from home for an unbroken period of 12 months starting in the next 3 months?

Screening Questions		
<input checked="" type="checkbox"/>	Yes	10
<input type="checkbox"/>	No	

**OPEN ENDED**      What is your opinion of the way in which an organization can leverage efficient administration practices to engage in greater social responsibility? Please answer in paragraph format using no more than 100 words.

Screening Questions	
<p>&lt;sample answer text&gt;</p>	

**Subtotal**    20

---

[Return to Previous Page](#)

This page lists the questions that were used for a screening level.

For multiple-choice questions, the page shows which answer or answers the applicant chose and how many points those answers are worth.

For open-ended questions, the page shows the applicant's answer and how many points the applicant earned for that answer. If no evaluations have been submitted, then no points are shown.

## Rate Applicant Page

Use the Rate Applicant page (HRS\_RATE\_APP) to review an applicant's points for profile-related screening criteria.

Navigation:

Click the **Rate** icon in the Applicants grid on the Manage Job Opening Page: Applicant Screening Tab: Screening Results section.

This example illustrates the Rate Applicant page.

**Screen Applicants**

**Rate Applicant**

**Name** Bryan Noah  
**Applicant ID** 300075  
**Job Opening** 603283      Eben Coordinator 

 Save      Cancel      Previous Applicant | Next Applicant | Return to Previous Page

---

**Screening Levels** View All    First 1 of 2 Last

**Description** Preliminary

**Areas of Study**

There are no items for the Areas of Study section.

**Competencies**

Content Items Details		Personalize		View All		First 1-5 of 6 Last	
Item	Item Description	Evaluation Type	Rating	Score	Points	Required	
Abstract thinking	Proficiency	Self			5	<input type="checkbox"/>	
Analytical thinking	Proficiency	Self			5	<input type="checkbox"/>	
Organize & present ideas well	Proficiency	Self			5	<input type="checkbox"/>	
Recognized as job expert	Proficiency	Self			5	<input type="checkbox"/>	
Takes initiative & follows up	Proficiency	Self			5	<input type="checkbox"/>	

**School Education**

There are no items for the School Education section.

**Language Skills**

Content Items Details		Personalize		View All		First 1-2 of 2 Last	
Item	Item Description	Rating	Score	Points	Required		
English	Language		5	5	<input checked="" type="checkbox"/>		
Spanish	Language			5	<input type="checkbox"/>		

**Important!** You cannot use this page to modify application data, only to review it and to see if any data (such as competency ratings) is missing. To enter applicant ratings or make other changes to the application data, use the [Application Details Page](#).

<b>Field or Control</b>	<b>Description</b>
	Click the <b>Application</b> icon to access the <a href="#">Application Details Page</a> , where you can enter the missing ratings.

<b>Field or Control</b>	<b>Description</b>
<b>Previous Applicant and Next Applicant</b>	Use these links to scroll through the data for all of the applicants who are listed in the grid from which you accessed this page.
Return to Previous Page	Click to return to the Manage Job Opening page: Applicant Screening tab: Screening Results section.

## Screening Levels

Scroll through each screening level to see an applicant’s profile-related screening points.

### <Content Type>

The page displays grids for every content item that is included in the job opening template, even when the screening level does not use the content item as screening criteria. The grid titles correspond to the name of each content type.

<b>Field or Control</b>	<b>Description</b>
<b>Item</b> and Item Description	Describes a specific qualification that can be used during screening.
<b>Rating</b>	If the content type uses a rating scale, this column displays the applicant's rating. This field is empty for content types that do not have a rating scale.
<b>Score</b>	Displays the number of screening points that the applicant receives for the content item.
<b>Points</b>	Displays the maximum possible number of screening points possible for the content item for the screening level.  The point value for a qualification comes from the <a href="#">Job Opening - Screening Criteria Page</a> , where you configured job-specific requirements for a screening level.
<b>Required</b>	Displays a selected check box if the qualification is marked required on the Job Opening - Screening Criteria page. The check box is deselected if the qualification is not required.

## (USF) Set Competitive Status Page

Use the Set Competitive Status page (HRS\_SCR\_MRK\_SEC) to assign an applicant’s competitive or non-competitive status for US Federal recruiting purposes.

Click the **Set Competitive Status** button on the Manage Job Opening Page: Applicant Screening Tab: Screening Results section.

This example illustrates the Set Competitive Status page.

<b>Field or Control</b>	<b>Description</b>
<b>Competitive Status</b>	Select the status to assign to the selected applicants: <i>Competitive, Non-Competitive Other, or Noncompetitive VRA</i> (noncompetitive veterans recruitment appointment).
<b>OK</b>	Click to assign the selected status and return to the screening results.
<b>Cancel</b>	Click to return to the screening results without assigning the selected status.

## (USF) Ranking Applicants and Generating the Certificate of Eligibles

This topic provides an overview of the federal ranking process and discusses how to rank applicants and generate a Certificate of Eligibles.

### Pages Used to Rank Applicants and Generate the Certificate of Eligibles

<b>Page Name</b>	<b>Definition Name</b>	<b>Usage</b>
<a href="#">Rank Applicants Page</a>	HRS_JO_RANK	Rank applicants.
<a href="#">Rank Applicants (Details) Page</a>	HRS_APP_RNK_RSLT	Review how many total points the applicant earned across all screening levels and through preference items, and review a breakdown of this number by screening level and by type of screening criteria.
<a href="#">Certificate of Eligibles (Certificate Data) Page</a>	HRS_G_CRT_ELG	Set up a certificate of eligibles.

<b>Page Name</b>	<b>Definition Name</b>	<b>Usage</b>
<a href="#">Certificate of Eligibles (Print Certificate) Page</a>	HRS_RUN_HRS821	Print a certificate of eligibles.

## Understanding The Federal Ranking Process

This overview describes the federal ranking process

### Competitive/Noncompetitive Status

All applicants must have a competitive/noncompetitive status in order to be included in the final applicant ranking. Competitive/noncompetitive status is a person's basic eligibility for assignment to a position in the competitive service without having to compete with members of the general public in an open competitive examination.

The available statuses are *Competitive*, *Non-Competitive Other*, or *Noncompetitive VRA* (noncompetitive veterans recruitment appointment).

Assign statuses on the [Manage Job Opening Page: Applicant Screening Tab: Screening Results Section](#) before you access the Rank Applicants page to begin the ranking process. The Rank Applicants page lists only applicants who have been assigned a status.

### Applicant Classification

The Rank Applicants page displays a screening score for each applicant. The score is the sum of the applicant's scores for individual screening levels and any veterans preference points.

As you begin the ranking process, you determine the score thresholds that the system uses to classify candidates as qualified, well-qualified, or best-qualified.

The system then considers these qualification classifications along with the applicants's priority processing status and places applicants in these four categories:

- Category 1: Qualified, well qualified, and best qualified applicants with *Must Select* priority placement.
- Category 2: Well qualified and best qualified applicants with *Must Consider* priority placement.
- Category 3: Best qualified applicants with no priority placement.
- Category 4: Qualified and well qualified applicants with no priority placement.

The screening rules that you configure determine which categories of applicants are included in the final ranking.

There are separate rules for competitive applicants and noncompetitive applicants. So, for example, you might include all four categories for noncompetitive applicants, but only the first three categories of competitive applicants.

## Tie-Breakers

If two or more applicants have the same score in the same category, you can apply one of three tie-breaker methods:

- Augmenting Factors, which uses criteria identified as Augmenting on the screening criteria.
- Name Request, which gives priority to applicants whose name are listed in the Candidate Name Request grid on the job opening.
- Random Number, which uses an algorithm based on the number that you entered in the Tie Breaker Number field in the Federal group box in the screening options section of the job opening.

## Certificate of Eligibles

After you have ranked the applicants, you are ready to certify the best-qualified applicants for the position. The OPM regulates the definition of eligibles and the order in which they should appear on the certificate. To generate the certificate of eligibles:

1. Click the **Create Certificates** button on the [Rank Applicants Page](#),
2. Use the [Certificate of Eligibles \(Certificate Data\) Page](#) to enter additional information for the certificate.
3. Use the [Certificate of Eligibles \(Print Certificate\) Page](#) to run the report that produces the certificate.

## Prerequisite

The US Federal ranking process includes only applicants who have been assigned a competitive status. Before ranking applicants and generating a certificate of eligibles, use the [Manage Job Opening Page: Applicant Screening Tab: Screening Results Section](#) to assign these statuses.

## Rank Applicants Page

Use the Rank Applicants page (HRS\_JO\_RANK) to rank applicants.

Navigation:

Click the **Rank Applicants** button on the Screening Results page.

This is the first of two examples illustrating the Rank Applicants page.

**Screen Applicants**  
**Rank Applicants**

**Posting Title** Admin Assistant  
**Job Opening Status** 010 Open  
**Job Title** Administrative Assistant  
**Position Number** LEP00032 Administrative Assistant  
**Business Unit** LEBU Federal Planning & Analysis  
**Department** LE0056  
**Job Family**

[Print Job Opening](#)  
**Job Opening ID** 30040  
**Job Type** Standard Requisition  
**Job Code** LEJ006

[Return to Previous Page](#)

---

**Applicants** Find | View All | First 1 of 2 Last

**Job Opening ID** 30040 **Admin Assistant**  
**Job Code** LEJ006 **GS - 0318 - 07 - Administrative Assistant**

Competitive <span style="float: right;">Personalize   Find   View All   First 1 of 1 Last</span>									
Rank	Score	Points	Category	Weight	Name	ID	Date	Qualifications Determination	
<input type="text"/>	0%	56.0			Kerry O'Reilly	1042	02/15/2005	Eligible/Not Rated	

Noncompetitive <span style="float: right;">Personalize   Find   View All   First 1 of 1 Last</span>									
Rank	Score	Points	Category	Weight	Name	ID	Date	Qualifications Determination	
<input type="text"/>	Score	0.0			Jose Campos	1022	02/15/2005	Eligible/Not Rated	

This is the second of two examples illustrating the Rank Applicants page.

**Qualify Applicants**

Best Qualified Score  Well Qualified Score

---

**Create Certificates**

Applicants to Consider  Certificate Number

---

**Tie Breaker**

Tie Breaker Option

[Return to Previous Page](#)

### Competitive and Noncompetitive

These grids list the applicants from the job opening; applicants are segregated according to the competitive status that you manually assigned on the screening pages. The Noncompetitive grid includes applicants with either of the two noncompetitive statuses.

<b>Field or Control</b>	<b>Description</b>
<b>Rank</b>	Initially this field is blank. When you qualify the applicants (by entering the thresholds for best qualified and well qualified and then clicking the Qualify Applicants button), the system assigns a ranking to the applicant. This field can be overridden.



<b>Field or Control</b>	<b>Description</b>
<b>Score</b>	<p>Displays the percent of the maximum points that the applicant attained. The maximum point value is manually entered on the screening section on the Job Opening page; there is no requirement for it to be the true maximum amount of points possible.</p> <p>Click the score to access a detail page that shows a breakdown of how the points were earned, both by screening level and by screening criteria type.</p>
<b>Points</b>	<p>Displays the total points that the applicant accumulated during the screening process, including veteran's preference points.</p>
<b>Category</b>	<p>Indicates which of four applicant categories the applicant belongs to. These categories are based on a combination of the applicant's priority placement status for the job opening and the applicant's qualification classification (best qualified, well qualified, or qualified).</p> <p>See <a href="#">Understanding The Federal Ranking Process</a>.</p> <p>This column is blank when you begin the ranking process. This is because the qualification classification is not set until you enter score thresholds and click the <b>Qualify Applicant</b> button. After you click the <b>Qualify Applicant</b> button, the system updates the Competitive and Noncompetitive grids with each applicant's qualification determination and category.</p>
<b>Weight</b>	<p>Displays the weight factor from the applicant's priority placement code. The weight does not affect the score; it is used to prioritize which priority placement code to use when an applicant has more than one.</p>
<b>Name and ID</b>	<p>These fields identify the applicant. Click a name to access the <a href="#">Manage Applicant Page</a>.</p>
<b>Date</b>	<p>Displays the date that the applicant was added to the list of competitive or noncompetitive applicants.</p>

<b>Field or Control</b>	<b>Description</b>
<b>Qualifications Determination</b>	<p>Displays the applicant's qualification level.</p> <p>Before you click the Qualify Applicants button, the value is <i>Eligible/Not Rated</i>.</p> <p>After you click the Qualify Applicants button, the value is <i>Qualified, Well Qualified, or Best Qualified</i>, depending on where the applicant's score falls with regards to the thresholds that you enter in the <b>Best Qualified Score</b> and <b>Well Qualified Score</b> fields.</p>

### Qualify Applicants

Use this group box to set score thresholds for best qualified and well qualified applicants and to assign applicants a qualification status based on these thresholds.

<b>Field or Control</b>	<b>Description</b>
<b>Best Qualified Score</b>	Enter the minimum score an applicant must achieve to be given a <i>Best Qualified</i> determination.
<b>Well Qualified Score</b>	Enter the minimum score an applicant must achieve to be given a <i>Well Qualified</i> determination.
<b>Qualify Applicants</b>	Click this button to assign qualification determinations to all applicants. Applicants with scores under the threshold for <i>Well Qualified</i> status are given the status <i>Qualified</i> .

### Create Certificates

This group box is used to process the Certificate of Eligibles.

<b>Field or Control</b>	<b>Description</b>
<b>Applicants to Consider</b>	Enter the number of applicants you want included in the certificate.
<b>Certificate Number</b>	Enter the number of the certificate.
<b>Create Certificate</b>	Click to process the certificate of eligibles.

## Tie Breaker

If any of the applicants are tied, use this section to apply a tie breaker method.

<b>Field or Control</b>	<b>Description</b>
<b>Tie Breaker Option</b>	Select one of these tie-breaker methods: <ul style="list-style-type: none"> <li>• <i>Augment</i>: The winner of the tie is the applicant with more points earned for Augmenting criteria (criteria for which you selected the <b>Augment</b> check box on the Job Opening - Screening Criteria page).</li> <li>• <i>Name Request</i>: Applicants listed on the Applicant Name Request page on the job opening win ties.</li> <li>• <i>Random Number</i>: The system breaks ties using an algorithm that uses a number that you enter in the Applicant Screening section of the Job Opening page. (Specifically, the number is in the Tie Break Number field in the Federal group box.)</li> </ul>
Apply Tie Breaker	Click this button to update the applicant rankings based on the selected tie-breaker method. If there are still ties after you apply one tie-breaker method, you can select another method and apply it.

## Rank Applicants (Details) Page

Use the Rank Applicants (details) page (HRS\_APP\_RNK\_RSLT) to review how many total points the applicant earned across all screening levels and through preference items, and review a breakdown of this number by screening level and by type of screening criteria.

Navigation:

Click the value in the **Score** column on the Rank Applicants page.

This example illustrates the Rank Applicants (details) page.

Screen Applicants

## Rank Applicants

Kerry O'Reilly

Applicant ID 1042

---

[Return to Previous Page](#)

---

**Job/Job Opening Summary** [Find](#) | [View All](#)    First ◀ 1 of 2 ▶ Last

Job Opening ID 30040	Admin Assistant
Job Code LEJ006	GS - 0318 - 07 - Administrative Assistant

**Screening Level Summary** [Find](#) | [View All](#)    First ◀ 1 of 3 ▶ Last

Grand Totals	
Screening Points 0.0	Level Score 56.0

**Level Points Detail**

General Requirements 50	Augmentation Points 0.0
Education/Experience 0	Selective Factor Points 0.0
JPM Content Score 0	Veterans Preference Points 0
Screening Questions 0	

---

[Return to Previous Page](#)

This page, like the [Screening Details Page](#), shows the sources of the points that were awarded to applicants during the screening process. The first record in the scroll level displays grand totals across all screening level.

## Certificate of Eligibles (Certificate Data) Page

Use the Certificate of Eligibles (certificate data) page (HRS\_G\_CERT\_ELG) to set up a certificate of eligibles.

Navigation:

**Recruiting > Administration > Setup Certificate of Eligibles**

This example illustrates the Certificate of Eligibles (certificate data) page.

### Certificate of Eligibles

Job Opening ID 4  
 Recruitment Type Open Competition  
 Status Code 010

Certificate of Eligibles Detail
Find | View All    First 1 of 1 Last

Job Code 000003     Primary

Certificate of Eligibles Nbr

Certificate Status

Certificate Source

Date of Request <input type="text"/>	Date Received <input type="text"/>
Due Date <input type="text"/>	Date Returned <input type="text"/>
Date Sent to SO <input type="text"/>	Issue Date <input type="text"/>
Date Returned from SO <input type="text"/>	Extension Date <input type="text"/>

Enter data related to the certificate of eligibles.

## Certificate of Eligibles (Print Certificate) Page

Use the Certificate of Eligibles (print certificate) page (HRS\_RUN\_HRS821) to print a certificate of eligibles.

Navigation:

**Recruiting > Reports > Run Certificate of Eligibles**

This example illustrates the Certificate of Eligibles (print certificate) page.

### Certificate of Eligibles

Run Control ID PS    Report Manager    Process Monitor    Run

Certificate of Eligibles Detail
Find | View All    First 1 of 1 Last

\*Certificate of Eligible Number

Job Opening ID 4

Job Code 000003

Enter the certificate number, then run the report.



## Chapter 23

# Routing Applicants

---

## Routing Applicants

This topic provides an overview of applicant routing and discusses how to manage routings

### Pages Used to Route Applicants

<i>Page Name</i>	<i>Definition Name</i>	<i>Usage</i>
<a href="#"><u>Route Applicant Page</u></a>	HRS_GACT_APP_RTE	Route an applicant to a recipient who is expected to provide a recommendation regarding the next step in the recruiting process.
<a href="#"><u>Include Attachments Page</u></a>	HRS_RTEATT_TYP_SEC	Choose which types of attachments to include with a routing request.
<a href="#"><u>Preview Notification Page</u></a>	HRS_RTE_PRVW_SEC	Preview a routing notification
<a href="#"><u>Manage Routings Page</u></a>	HRS_APP_RTE_SUM	Review and manage existing routings, including sending reminder notifications to routing recipients.  This page is nearly identical to the <a href="#"><u>Manage Application Page: Route Tab</u></a> .
<a href="#"><u>Edit Routing Page</u></a>	HRS_GACT_APP_RTE	Update an existing routing and enter routing responses on behalf of recipients.
<a href="#"><u>Routing Response Comments Page</u></a>	HRS_RTE_RESCMT_SEC	View comments from a routing recipient or enter comments on the recipient's behalf.
<a href="#"><u>Route Response Reminder Page</u></a>	HRS_RSPN_RMNDR	Schedule reminder notifications for routing recipients and to specify when (relative to the response due date) to send those reminders.

## Understanding Applicant Routing

Routing is the action of sending applicant information to recipients who are asked to provide input on the next step to take for the applicant. The term *Routing* refers to the action of sending the request and to the request itself.

### The Route Applicant Action

The Route Applicant action is available from several pages, including the Manage Job Opening page, Manage Applicant page, Manage Application page, and Search Applications page.

The Route Applicant action provides access to two pages:

- The [Route Applicant Page](#) appears when you perform the Route Applicant action for an application that does not already have a routing or if you perform a group action on multiple applications.

Use this page to create and send a new routing.

- The [Manage Routings Page](#) appears when you perform the Route Applicant action for a single application that already has at least one routing.

Recruiters use this page to view summary information about an applicant's routing. Although the page is mostly read-only, users can update the overall routing status and send reminders to recipients who have not yet responded. This page is similar to the [Manage Application Page: Route Tab](#), except that the Manage Routings page lets you update the overall routing status directly on the page rather than requiring you to access a separate editable page.

The Route Applicant action is also available as a group action. When a routing includes multiple applicants, you can choose whether recipients receive separate emails for each applicant or just one consolidated email that lists all applicants.

---

**Note:** If a job opening is governed by a flexible recruiting process, that process controls the availability of the Route Applicant action. Availability can vary depending on the user's role and the applicant's current disposition.

---

### Routing Statuses

Routings have their own status, separate from the applicant's disposition. When you create a routing request, you can assign the initial routing status. The delivered default routing status is *Routed*, indicating that you have sent the routing and you are in the process of collecting responses.

The other delivered routing statuses describe the possible decisions you can make for the applicant. You select the appropriate status after you receive feedback from routing recipients.

These are the delivered status values for the Route status area:

- *Routed* indicates that the applicant has entered the routing phase and that you are seeking recommendations for further applicant processing.
- *Invite for Interview* indicates that you intend to proceed to the next step in the recruiting process by inviting the applicant to interview.
- *Hold* indicates that you do not intend to make a decision yet.



- *Reject* indicates that you are not interested in the applicant.
- *Withdrawn* indicates that the applicant is no longer available for the job opening. This disposition is assigned by the Withdraw from Hire action.
- *Withdrawn Application* indicates that the application was withdrawn from consideration. This disposition is assigned by the Withdraw Application action. It is also assigned when an applicant uses Candidate Gateway self-service to withdraw the application.

Changes to the routing status can trigger status change effects that update the applicant's disposition. For example, the creation of a new routing record with the status *Routed* changes the applicant's disposition to *Routed* (depending on the original disposition at the time of the routing). Changing the routing status to *Reject* will change the applicant's disposition to *Reject*.

See [Delivered Status Change Effects](#).

## Routing Responses

The notification that the system sends to routing recipients includes a link to the self-service Routing Response page, where the user can review a list of routing requests and access a detail page to supply a response for a specific routing. The response options are the same status values that are used for the overall routing status.

After a routing has been sent, a recruiting user can enter a response on behalf of a routing recipient. The original recipient can still access the routing request and change the response.

After a recipient submits a response using the self-service Routing Response page, the response is read-only. Neither the recipient nor the recruiter can make further changes.

## Notifications and Templates

Routing notifications are sent to the email address from the recipient's personal data record. The following table lists the templates that are used during the routing process:

<b>Template Name and Description</b>	<b>When Used</b>
HRS_APP_CONS_RTE Consolidated Route Email	To notify a routing recipient of a routing for multiple applicants. This template is used when the "Consolidated all applicants in one email" check box is selected (that is, recipients receive a single email for all routed applicants rather than a separate email for each applicant.).
HRS_APP_RTE Applicants Route Notification	To notify a routing recipient of a routing for a single application when the application is associated with a job opening.
HRS_APP_RTE_NOJOB Application Route - No Job	To notify a routing recipient of a routing for a single application when the application is not associated with a job opening.

<b>Template Name and Description</b>	<b>When Used</b>
HRS_RTE_RSPN Route Response Notification.	To notify the person who created a routing that a response has been entered in the self-service Routing Response page.
HRS_RTE_RSPNS_RMNDR Route Response Reminder Email	To remind a routing recipient of a routing when the routed application is associated with a job opening.
HRS_RTE_RSPN_NOJOB Route Response Notification.	To remind a routing recipient of a routing when the routed application is not associated with a job opening.

**Note:** The reminder notifications can be triggered several ways. User can run a batch reminder process from the [Route Response Reminder Page](#), or they can manually click a Send Reminder link on the [Manage Routings Page](#) or the [Manage Application Page: Route Tab](#).

## Batch Routing Notifications

The Route Applicant action sends email notifications in real-time as long as the number of notifications does not exceed the Batch Action Threshold specified on the [Recruiting Installation – Applicants Page](#). When the number of notifications exceeds the threshold, the Group Action Notification (HRS\_ACT\_MAIL) Application Engine process sends the notifications in batch.

The Batch Action Threshold refers to the number of email notifications to be sent, not the number of applicants being processed. For example, if five applicants are selected for routing, and they are routed to five recipients (without consolidating applicants into one email per recipient), the transaction involves 25 notifications.

If the batch process does not successfully send all notifications, the user who performed the route action receives a failure notification. The notification, which uses the PeopleTools Workflow HRS\_BATCH\_NOTIFY template, advises the user to contact a system administrator, who can restart the batch process. Because the batch process tracks notifications as they are sent, no duplicate notifications are sent if the process is re-started.

Regardless of whether notifications are sent in real-time or in batch, the routing record is saved as soon as the routing is submitted, and all related online changes are immediately visible. In particular, the routing requests are immediately visible on the self-service Routing Response page even if the email notifications are delayed.

## Route Applicant Page

Use the Route Applicant page (HRS\_GACT\_APP\_RTE) to route an applicant to a recipient who is expected to provide a recommendation regarding the next step in the recruiting process.

Navigation:

Click the **Route** icon for an applicant who does not yet have any routings, or select **Recruiting Actions > Route Applicant** from the Group actions menu. You can perform the routing action on any of these pages:

- Manage Job Opening page: Applicant tab
- Manage Applicant page: Applicant Activity tab: Current Status section
- Search Applications
- Manage Application (group action not available)

This example illustrates the Route Applicant page.

## Toolbar

<b>Field or Control</b>	<b>Description</b>
<b>Submit</b>	<p>Click to finalize the routing information. When you submit, The system emails a routing notifications to all recipients. The email includes a link to the self-service Routing Response page, where the recipient can view and respond to the routing request.</p> <p>Submitting a new routing record also triggers status change effects. As delivered, a new routing record with the default status of <i>010 Route</i> causes applicants who started in the <i>Review, Linked, Applied, Screen, or Hold</i> dispositions to be put into the <i>050 Route</i>.</p>

<b>Field or Control</b>	<b>Description</b>
<b>Return</b>	Click to return to the page where you initiated the Route Applicant action. A routing that has not been submitted is not saved for later, so the user is prompted to confirm the return action if any data has been entered on the page.

## Applicants to Route

This grid lists the names and IDs of the applicants that you are routing, along with the job openings for which they are being considered.

If you used a group action to create a routing for multiple applicants, you can remove applicants from the list until just one applicant remains. You cannot, however, add additional applicants. Instead, return to the page where you initiated the routing action and route any additional applicants from there.

## Routing Details

<b>Field or Control</b>	<b>Description</b>
<b>Routing Status</b>	<p>The values in this drop-down list box are the statuses configured for the Route status area on the <a href="#">Recruiting Status and Reason Page</a>.</p> <p>When initiating a routing request, choose routing status that indicates that the routing has been sent and is in progress. As delivered, the default status in this area is <i>010 Route</i>.</p> <p>The other values for this field are used to indicate the next step to take for the applicant. You will select one of these values after gathering responses from routing recipients. The delivered options include <i>020 Invite for Interview</i>, <i>100 Hold</i>, <i>110 Reject</i>, <i>120 Withdrawn</i>, and <i>130 Withdrawn Application</i>.</p> <p>See <a href="#">Understanding Recruiting Statuses</a>.</p>
<b>Reason</b>	<p>Optionally select a reason for assigning the selected routing status. Values depend on your status configuration. If the selected routing status does not have any associated reasons, then the Reason drop-down list box does not have any values.</p>

## Recipients

Use the Recipients grid to identify the people whose feedback you are requesting. If the routing request is for a single job opening, the primary hiring manager is the default recipient unless the hiring manager is the person sending the routing request.

**Note:** You cannot use the Route Applicant page to enter routing responses on behalf of a recipient because the routing must be sent before responses can be entered. However, on the [Edit Routing Page](#) (an editable version of the Route Application page), this grid includes additional fields for entering routing responses.

<b>Field or Control</b>	<b>Description</b>
<b>Routing Date</b>	<p>Displays the date that the routing was sent to this recipient. The default value is the current date.</p> <p>Routing notifications are sent immediately when you submit the routing, so you normally should not modify the default date. However, if you previously routed the applicant manually, you can enter the date of the manual routing for historical purposes.</p>
<b>Name</b>	<p>Enter the name of the person to whom you are routing the applicant. If the person's personal data record does not have an email address, a warning message will appear when you submit routing.</p>
<b>Assignment</b>	<p>If the routing request is for a single job opening, this field displays the recipient's association to the job opening. <i>Approver/Reviewer, Interviewer, Interested Party, Manager, Originator, Recruiter, or Screening Team.</i></p> <p>This field remains blank for recipients who do not have any of these associations with the job opening.</p>
<b>Response Due Date</b>	<p>Enter a date by which the recipient should respond with a recommendation regarding the applicant. When you add a new row, the due date from the previous row is the default value.</p> <p>The batch process that sends reminders to routing recipients uses this date to determine when to send reminders. The batch process does not send reminders to recipients who do not have a due date.</p> <p>The system does not look this date when a user manually sends reminders from the <a href="#">Manage Routings Page</a> or the <a href="#">Manage Application Page: Route Tab</a>.</p>
<b>Add Recipient</b>	<p>Click to add another recipient to the routing.</p>

<b><i>Field or Control</i></b>	<b><i>Description</i></b>
<b>Add Hiring Team</b>	<p>This button is visible only if the routing request is for a single job opening. Click the button to add all of the hiring team members as routing recipients. Hiring team members are the people identified in any of the assignment-related sections of the job opening. The job opening originator is not considered a hiring team member and is not added to the routing request.</p> <p>Because it does not make sense to route an applicant to yourself, the current user is not added to the grid even if the user is a member of the hiring team.</p>

## Notification

<b><i>Field or Control</i></b>	<b><i>Description</i></b>
<b>Comments</b>	<p>Enter comments to be included in the routing request email notification.</p> <p>If you later return to this routing request to add more recipients, you can use original comments or edit them for any new notifications.</p> <p>Comments are used only in the notification email. They do not appear on the self-service <a href="#">Routing Response Details Page</a> or on the <a href="#">Manage Application Page: Route Tab</a> .</p>
<b>Consolidate all applicants in one email</b>	<p>This check box is visible only if the routing includes multiple applicants. Select this check box to send a single email to each recipient. That email will list all of the applicants who are being routed. If the check box is not selected, the recipient receives a separate email notification for each applicant in the routing.</p>
<b>Include Attachments</b>	<p>Click to access the <a href="#">Include Attachments Page</a>, where you choose which applicant attachments types to associated with the routing. Associated attachments are always visible on the self-service routing response page, and you can optionally attach them to the notification email as well.</p> <p>By default, resumes and cover letters are included with the routing, but other attachment types are not.</p>

<b>Field or Control</b>	<b>Description</b>
<b>Preview Notification</b>	Click to access the <a href="#">Preview Notification Page</a> page, where you can preview the email notification that will be sent to the recipient. You can also modify the default notification subject on the Preview Notification page.
<b>Notify me when a Recipient responds.</b>	Select this check box if you want to receive notifications when recipients submit their responses using the self-service routing response page.

## Include Attachments Page

Use the Include Attachments page (HRS\_RTEATT\_TYP\_SEC) to choose which types of attachments to include with a routing request.

Navigation:

Click the **Include Attachments** button on the Route Applicant page or the Edit Routing page.

This example illustrates the Include Attachments page.

**Include Attachments**

**Attachments** ?

Select	Attachment Type
<input checked="" type="checkbox"/>	Resume
<input type="checkbox"/>	References
<input type="checkbox"/>	Transcripts
<input checked="" type="checkbox"/>	Cover Letters
<input type="checkbox"/>	Personal References
<input type="checkbox"/>	Professional References
<input type="checkbox"/>	OIF

Send via Email

OK Cancel

Applicant attachments are classified using attachment types that you configure on the [Attachment Type Setup Page](#).

When applicants upload attachments in Candidate Gateway, they must indicate the attachment type. When recruiters upload attachments on the Application Details page, they can optionally indicate the attachment type, but attachments without an attachment type cannot be included in a routing.

<b>Field or Control</b>	<b>Description</b>
<b>Attachments</b>	<p>Select the types of attachments to include in the routing. The selection grid includes all active attachment types from the <a href="#">Attachment Type Setup Page</a>. By default, the <b>Resumes</b> and <b>Cover Letter</b> attachments types are selected.</p> <p>Resumes that were entered into the system as text (rather than being uploaded as attachments), are attached to the email notification as a .html file.</p> <p>If the Cover Letters check box is selected and there is a cover letter associated with the job opening, the routing includes only that cover letter. Applicant-level cover letters are not included in the routing unless there is not an application-specific cover letter.</p> <p>For other attachment types, both applicant-level attachments and application-level attachments are included with the routing when the attachment type is selected.</p> <p>If attachments of the selected types are added or removed from the original application after a routing is sent, the self-service routing page automatically reflects these changes.</p> <p>When you send a new routing, Inactive attachment types are not listed on this page. However, previously active attachment types that were included in a routing are shown read-only if you access this page for the old routing.</p>
<b>Send via Email</b>	<p>Select this check box to include the selected attachments in the email notifications that the routing process sends. The self-service Routing Response page always provides recipients with access to the selected attachments, regardless of whether you also include the attachments in the email notification.</p> <p>This check box applies to all applicants in the routing and to all selected attachment types. You cannot email a subset of the attachments except by creating multiple routings with different attachment settings.</p> <p>Attaching files to the email notification may be convenient for the recipient, but it also causes the email size to increase dramatically.</p> <hr/> <p><b>Important!</b> Consider your organization's email policies and practices before sending large attachments or a high volume of attachments with your routing notifications.</p> <hr/>

## Preview Notification Page

Use the Preview Notification page (HRS\_RTE\_PRVW\_SEC) to preview a routing notification.



Navigation:

Click the **Preview Notification** button on the Route Applicant page or the Edit Routing page.

This example illustrates the Preview Notification page.

**Preview Notification**

**Recipient(s)**

To Ponciano Batalang, Joyce Hayden

**Message**

**\*Subject** Applicant that needs your review

**Message**

Dear Ponciano Batalang,

You have been asked to review the following applicant, [Nora Dooley](#), as a potential candidate for the job opening of 300254, Manager-Employee Relations. Your response is due by Tuesday, August 05,2014.

**Comments:**  
This applicant is an employee referral.

Please access the following page to view applicant attachments and to enter your response whether to invite the applicant for an interview.

[Route Response](#)

Regards,  
Betty Locherty

Note: The applicant attachments sent in the email have been renamed.

**Attachments** ?

Original File Name	New File Name
N_Dooley_Resume.pdf	Nora_Dooley_Resumes_300254.pdf
N_Dooley_Cover_Letter.pdf	Nora_Dooley_Cover_Letters.pdf

<b>Field or Control</b>	<b>Description</b>
<b>To</b>	Displays the names of all notification recipients. When you initially send a routing, all routing recipients receive notifications. If you edit a routing, the recipient list on the Edit Routing page includes a Notify check box so that you can select a subset of recipients for the notification.
<b>Subject</b>	Enter a subject for the notification. This is the only editable field on this page. The default subject from the HRS_APP_RTE template is <i>Applicant that needs your review</i> or <i>Applicants that need your review</i> .

<b>Field or Control</b>	<b>Description</b>
<b>Message</b>	<p>Displays the text of the routing notification. The message is not editable. The template-based text varies according to context, but in general the message includes:</p> <ul style="list-style-type: none"> <li>• A salutation with the recipient’s name.</li> <li>• A request to review the applicant(s).</li> <li>• The applicant(s) names.</li> <li>• The job opening ID, if applicable.</li> <li>• The response due date, if one has been specified.</li> <li>• Comments from the Route Applicant or Edit Routing page, if any were entered.</li> <li>• Instructions to supply a response on the self-service Routing Response page, and a link to that page.</li> <li>• The senders name.</li> <li>• If there are attachments, a note stating that the files have been renamed.</li> </ul>
<b>Attachments</b>	<p>If you selected the Send Via Email check box on the <a href="#">Include Attachments Page</a>, this grid lists the email attachments. If there are multiple applicants in the routing, the grid lists only the attachments for the first applicant, even if you’ve chosen to send a consolidated email that lists all of the applicants.</p> <p>Click an attachment to view it. If the attachment is for a resume that was pasted into an application (rather than uploaded), clicking the attachment name opens the <a href="#">Resume Text Page</a> rather than opening a file. However, when the email notification is sent, the pasted resume is a regular file attachment.</p> <p>You cannot add or remove attachments from this grid. To change attachments, modify the settings on the Include Attachments page.</p> <p>Because the original files names of the attachments might not be self-explanatory, the system renames all emailed attachments using the format LastName_FirstName_AttachmentType. The job opening ID is appended to the file name if an applicant is being routed for more than one job opening. A sequence number is appended to the file name if an application includes more than one file of a particular file type.</p>
<b>OK</b>	Click to save any changes to the <b>Subject field</b> and return to the previous page.
<b>Cancel</b>	Click to discard any changes to the <b>Subject field</b> and return to the previous page.

## Manage Routings Page

Use the Manage Routings page (HRS\_APP\_RTE\_SUM) to review and manage existing routings, including sending reminder notifications to routing recipients.

Navigation:

Perform the Route Applicant action on an application that already has at least one routing. To perform the action, click the **Route** icon on any of these pages:

- Manage Job Opening page: Applicant tab
- Manage Applicant page: Applicant Activity page: Current Status section
- Search Applications
- Manage Application

---

**Note:** If the application does not yet have a routing, or if you use a group action, the system displays the Route Applicant page instead of the Manage Routings page.

---

This example illustrates the Manage Routings page.

The screenshot shows the 'Manage Routings' page for applicant Nora Dooley. It includes a header with 'Save' and 'Return' buttons, applicant and job opening details, a 'Routing Summary' table with one entry, 'Routing Details' with dropdowns for status and reason, and a 'Recipients' table with two entries. At the bottom, there is an 'Add New Routing' button and another 'Save'/'Return' pair.

Select	Status Date	Route Status	Responses Received	Responses Remaining	
<input checked="" type="radio"/>	07/30/2014	010 Route	1	1	

Route Date	Name	Assignment	Response Due Date	Response	Response Date	Comments
07/30/2014	Ponciano Batalang		08/05/2014	020 Invite for Interview	07/30/2014	
07/30/2014	Joyce Hayden		08/05/2014			

### Toolbar

Field or Control	Description
Save	Click to save changes to the <b>Route Status</b> and <b>Reason</b> fields.
Return	Click to return to the page where you initiated the Route Applicant action.

## Header

The header area of this page displays identifying information about the applicant and about the job opening for which the applicant is being routed. This page requires the context of a single applicant and a single job opening (or an application without a job opening).

## Routing Summary

This grid lists all of the applicant’s routings for the specified job opening. Routings are listed in reverse chronological order, with the most recent routing listed first.

<b>Field or Control</b>	<b>Description</b>
<b>Select</b>	Select the routing to be displayed in the Routing Details section of the page.
<b>Status Date</b>	Displays the date that the overall Route Status was last updated.
<b>Route Status</b>	Displays the current overall Route Status.
<b>Responses Received</b>	Displays the number of recipients who have supplied a response. It doesn’t matter whether the recipient entered the response through self-service or a recruiter entered a response on behalf of the recipient.
<b>Responses Remaining</b>	Displays the number of recipients who have not supplied a response.
 <b>Edit</b>	Click to access the Edit Routing page to make changes to the routing.

## Routing Details

<b>Field or Control</b>	<b>Description</b>
<b>Route Status</b>	Displays an overall status of the routing. The delivered default status for a new routing is <i>Routed</i> , indicating that a request for feedback has been sent. Other delivered statuses describe the next step to be taken based on feedback from the routing recipients.
<b>Reason</b>	Displays the reason for the current routing status.

<b>Field or Control</b>	<b>Description</b>
<b>Edit Routing</b>	Click to access the Edit Routing page to make changes to the routing.
<b>Send Reminder</b>	<p>Click to send a notification to the recipients who have not yet supplied a response. The system sends the notification immediately (regardless of the response due date).</p> <p>This reminder uses the HRS_RTE_RSPNS_RMNDR notification template.</p> <p>This link is disabled if all recipients have supplied responses.</p>
<b>Recipients</b>	<p>This grid displays summary information about the routing recipients, including their responses. To access any response comments, click the Comments icon.</p> <p>Information in this grid is read-only. To enter response information on behalf of a recipient, or otherwise modify recipient information, click either the Edit Routing link (in the Routing Details section) or the Edit icon (in the Routing Summary grid).</p>

## Add New Routing

<b>Field or Control</b>	<b>Description</b>
<b>Add New Routing</b>	<p>Click to add an additional routing for the same applicants that are listed in the current routing.</p> <p>If you simply want to add new recipients to an in-progress routing, you can add the recipients to the existing routing instead. However creating a new routing is appropriate if the previous routing is finalized, or if you want to enter different comment text for the new recipients.</p>

## Edit Routing Page

Use the Edit Routing page (HRS\_GACT\_APP\_RTE) to update an existing routing and to enter routing responses on behalf of recipients.

Navigation:

On the Manage Routings page or on the Route tab of the Manage Application page, click either the Edit Routing link or icon.

This example illustrates the Edit Routing page.

The screenshot shows the 'Edit Routing' interface. At the top, there are 'Submit' and 'Return' buttons. Below is a table for 'Applicants to Route' with columns for Applicant ID, Name, and Job Opening. The main section is 'Routing Details', which includes a dropdown for 'Routing Status' (set to '010 Route') and a 'Reason' dropdown. A 'Recipients' table follows, with columns: Notify, Routing Date, Name, Assignment, Response Due Date, Response, and Response Date. Two recipients are listed: Ponciano Batalang and Joyce Hayden. Below the table are 'Add Recipient' and 'Add Hiring Team' buttons. A 'Notification' section contains a text area with the comment 'This applicant is an employee referral.', 'Include Attachments', and 'Preview Notification' buttons. At the bottom, there is a checked checkbox for 'Notify me when a Recipient responds' and another 'Submit' and 'Return' button set.

The Edit Routing page is a version of the [Route Applicant Page](#) page with additional options that are relevant only for a routing that has already been sent. The documentation that follows describes only these additional options.

**Note:** On the Edit Recipient page, you cannot edit information for recipients who supplied a response using the self-service Routing Response page. Neither recruiters nor routing recipients can modify responses that were submitted using self-service.

## Recipients

<b>Field or Control</b>	<b>Description</b>
<b>Notify</b>	<p>Select this check box to identify recipients who should receive a routing notification when you submit your changes to the routing. This check box is always selected for any newly added recipients. You can select the check box for existing recipients as long as they have not yet submitted a response via self-service. Reasons for re-sending a notification to an existing recipient might include a new response due date or new comments.</p> <p>If the Notify check box is selected for at least one recipient, the system sends the notification when you submit the page.</p>

<b>Field or Control</b>	<b>Description</b>
<b>Response</b>	<p>This field shows the recommendation from the routing recipient.</p> <p>This field (like the entire row) is read-only if the applicant submitted the response using self-service.</p> <p>If the recipient has not submitted a response, you can enter a response on the applicant's behalf. The response remains editable unless the applicant subsequently saves the response (changed or unchanged) on the self-service Routing Response page.</p>
Response Date	<p>Displays the date that the response was supplied.</p> <p>If the response was supplied in the self-service Routing Response page, the system enters the date, and the field is read-only.</p> <p>If you enter a response on the Edit Routing page, you should manually enter a response date because the system does not provide a default value. A response date that is entered on the Edit Routing page remains editable unless the applicant subsequently saves the response (changed or unchanged) on the self-service Routing Response page.</p>
 <b>Comments</b>	<p>Click to access the <a href="#">Routing Response Comments Page</a>.</p> <p>The icon appearance changes if comments are present. When there are no comments, the icon is a solid color. When comments exist, the icon has dots representing text on a page.</p>

## Routing Response Comments Page

Use the Routing Response Comments page (HRS\_RTE\_RESCMT\_SEC) to view comments from a routing recipient or to enter comments on the recipient's behalf.

You can only enter comments if you access the page from the Edit Routing page. You can also access this page in read-only mode from the Manage Routings page and from the Route tab of the Manage Application page.

Navigation:

Click the **Comments** icon on the Edit Routings page, the Manage Routings page, or the Route tab of the Manage Application page.

This example illustrates the Routing Response Comments page.



<b>Field or Control</b>	<b>Description</b>
<b>Comments</b>	Displays comments related to the routing response.  If the recipient entered the response using self-service, the comments are read-only.  If the recipient has not submitted a response, and if you accessed the page from the Edit Routing page, you can enter a response on the applicant's behalf. Comments entered on this page remain editable unless the recipient subsequently submits them using self-service.
<b>Updated By</b>	Displays the name of the person who last saved the comments. If the comments were submitted using self-service, no further changes can be made.
<b>OK</b>	If the page is editable, click this button to save your changes and return to the previous page.
<b>Cancel</b>	If the page is editable, click this button to discard changes and return to the previous page.
<b>Close</b>	If the page is not editable, click this button to return to the previous page.

## Route Response Reminder Page

Use the Route Response Reminder page (HRS\_RSPN\_RMNDR) to schedule reminder notifications for routing recipients and to specify when (relative to the response due date) to send those reminders.



Reminders are sent only when no response has been received for a routing with a response due date.

Navigation:

**Recruiting > Administration > Route Response Reminder**

This example illustrates the Route Response Reminder page.

<b>Field or Control</b>	<b>Description</b>
<p><b>Number of Days</b></p>	<p>Enter a number to indicate how many days before the due date to send the reminder. Recipients without a due date do not receive a reminder.</p> <p>If a recipient has multiple routing responses that are due on the same date, the system consolidates the reminders into a single email notification.</p> <p>You can add rows to this grid to schedule multiple reminders. For example, to send daily reminders starting two days before the due date, create three grid rows with the values 2, 1, and 0. The 0 means that the process sends a reminder on the response due date.</p> <p>This process never sends reminders after the due date has passed, but you can use the Send Reminder link on the Manage Routings page to manually send reminders.</p>
<p><b>Run</b></p>	<p>Click to access the PeopleSoft Process Scheduler Request page, where you schedule the Route Response Reminder (HRS_RTE_RMND) process.</p> <p>The best practice is to set up the request so that the reminder process runs daily.</p>

## Entering Routing Responses

This topic describes the self-service pages that routing recipients use to enter routing responses.

For an overview of the routing process, see [Understanding Applicant Routing](#).

## Pages Used to Enter Routing Responses

<b>Page Name</b>	<b>Definition Name</b>	<b>Usage</b>
<a href="#">Routing Response List Page</a>	HRS_APP_RTE_SRCH	View a list of routing requests that have been sent to you.
<a href="#">Routing Response Details Page</a>	HRS_APP_RTE_RSP	Enter a response to a routing request.
<a href="#">Resume Text Page</a>	HRS_RTE_RESTEX_SEC	View text resume details from the context of a routing.

## Routing Response List Page

Use the Routing Response list page (HRS\_APP\_RTE\_SRCH) to view a list of routing requests that have been sent to you.

Navigation:

- **Self Service > Recruiting > Applicant Routing Response**
- Users who receive a routing request can access this page using the link in the routing request email notification

This example illustrates the Routing Response list page.

**Routing Response**

The applicants listed were routed to you with a request for a response. To enter a routing response, select the applicant's name. To filter the applicant list, enter your filtering criteria in the date fields and in the Route Response field, then select the Refresh button.

\*Show Applicants Routed Between  and  Route Response

Applicant List for Routing Response							Personalize   Find   View All         First   1-3 of 3   Last
Applicant ID	Name	Route ID	Route Response	Route Date	Posting Title	Initiator	
1	300129 Karla Beneffer	1087		09/14/2015	Product Consultant - Sales	Betty Locherty	
2	300131 Brian Parkersohn	1088		09/14/2015	Product Consultant - Sales	Betty Locherty	
3	500290 Jessica Butler	1086		09/14/2015	Product Consultant - Sales	Betty Locherty	

## Filter Criteria

<b>Field or Control</b>	<b>Description</b>
<b>Show Applicants Routed Between</b>	Enter the date range for the routing requests you want to list on this page. This is matched against the route date shown in the <b>Applicant List for Routing Response</b> grid.

<b>Field or Control</b>	<b>Description</b>
<b>Route Response</b>	Select a value to filter the list by the routing response that you provided. The default value, <i>000 Pending</i> displays requests where no response has yet been provided. Select <i>All</i> to see all requests, both pending and completed.
<b>Refresh</b>	Click to update the list of routing requests based on the specified filter criteria.

### Applicant List for Routing Response

<b>Field or Control</b>	<b>Description</b>
<b>Applicant ID and Name</b>	<p>These fields identify the applicant who was routed. Click the applicant name to access the Routing Response details page, where you can supply your routing response.</p> <p>Each applicant that was routed to you is listed separately, even if the person who sent the routing used a group action to route multiple applicants at the same time.</p>
<b>Route Response</b>	<p>Displays the routing response if one has been saved. Responses can be entered by the routing recipient (on the Routing Response details page) or by a recruiting user on the <a href="#">Edit Routing Page</a>.</p>
<b>Route Date</b>	Displays the date that the routing was originally sent.
<b>Posting Title</b>	Displays the posting title for the job opening for which you are being asked to review the applicant.
<b>Initiator</b>	Displays the name of the person who routed the applicant.

### Routing Response Details Page

Use the Routing Response detail page (HRS\_APP\_RTE\_RSP) to enter a routing response.

Navigation:

Click the name of an applicant on the Routing Response list page.

This example illustrates the Routing Response detail page.

### Routing Response

Submit | Return | Previous
Personalize

Applicant Name Jessica Butler	Job Opening ID 504073
Applicant ID 500290	Job Opening Status 010 Open
Job Posting Title Product Consultant - Sales	Business Unit GBIBU (Global Business Institute BU)
Job Code 710005 (Product Consultant-Sales)	Position Number 19000006 (Compensation Specialist)

#### Response Details

Routing Date 09/14/2015	Response Due Date 09/18/2015
*Recommendation <input type="text"/>	
Comments <input style="width: 100%;" type="text"/>	

#### Attachments

Attachment	Attachment Title	Attachment Type
JKB_Resume.pdf	Jessica Butler Resume	Resume
JKB_Cover_Letter_Sales.pdf	J Butler Letter for Sales Jobs	Cover Letters

Submit | Return | Previous
Top of Page

## Toolbar

<i>Field or Control</i>	<i>Description</i>
<b>Submit</b>	<p>Click to save your changes on this page and return to the Routing Response list page. When you submit a response, this page becomes read-only. For this reason, be sure to enter any comments before submitting.</p> <p>If the routing was configured to send response notifications, submitting the response triggers the notification.</p>
<b>Return</b>	Click to return to the Routing Response list page.
<b>Previous and Next</b>	Use these buttons to navigate to other routing requests that were listed on the Routing Response list page..

## Header Information

The read-only fields at the top of the page identify the applicant and the job opening for which the applicant is being considered. A routing applies only to this specific context.

## Response Details

**Important!** These fields are editable if you have not yet submitted a response (including if a recruiter entered a response on your behalf). After you submit a response, these fields are read-only, and you cannot make further changes.

<b>Field or Control</b>	<b>Description</b>
<b>Routing Date</b>	Displays the date that the routing was sent.
<b>Response Due Date</b>	Displays the response due date that was set by the person who sent the routing request.
<b>Recommendation</b>	<p>Enter your recommendation regarding the next step to take for this applicant for the current job opening.</p> <p>Values come from the statuses that have been configured for the Route status area on the <a href="#">Recruiting Status Area Page</a>.</p>
<b>Comments</b>	Enter comments related to the routing response. Recruiting users can access these comments on the <a href="#">Routing Response Comments Page</a>

## Attachments

This grid lists the attachments that were included in the routing. The person who sends the routing uses the [Include Attachments Page](#) to choose additional attachment types to include.

**Note:** This grid can include attachments even if the original routing notification did not. This occurs when the person who sent the routing chose not to include attachments in the notification.

<b>Field or Control</b>	<b>Description</b>
<b>Attachment</b>	Displays the file name of the attachment. Clicking this link opens the file. Click the file name to open the attachment.
<b>Attachment Title</b>	<p>Displays the description provided by the person who uploaded the file. When a file is uploaded, the default description is the file name, but the user can modify this description.</p> <p>The title shown here most likely will not match the file name used for any email attachments. The system renames files that are attached to routing emails because the original files names of the attachments might not be self-explanatory.</p>
<b>Attachment Type</b>	Describes the purpose of the attachment.

## Resume Text Page

Use the Resume Text page (HRS\_RTE\_RESTEX\_SEC) to view text resume details from the context of a routing.

### Navigation:

On the Routing Response detail page or on the Preview Notification page, click the file name column for a resume that was pasted into an application rather than being uploaded.

This example illustrates the Resume Text page.

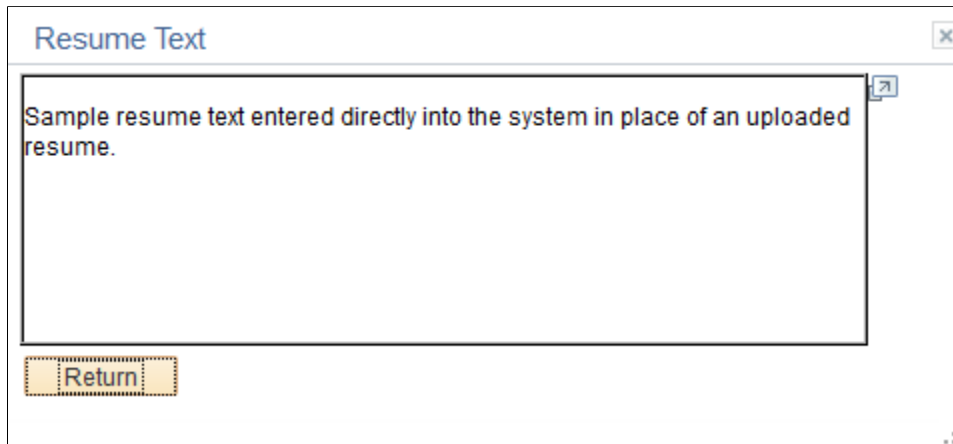

The screenshot shows a web application window titled "Resume Text". Inside the window, there is a large text input field containing the text "Sample resume text entered directly into the system in place of an uploaded resume." Below the text field is a button labeled "Return". The window has a standard title bar with a close button (X) in the top right corner. There are also small icons in the top right corner of the text field and bottom right corner of the window.

# Interviewing Applicants

---

## Maintaining Interview Facilities

Interview facilities are specific locations such as meeting rooms where interviews take place. In the context of an applicant's interview schedule, the facility is referred to as the *venue*.

### Page Used to Maintain Interview Facilities

<i>Page Name</i>	<i>Definition Name</i>	<i>Usage</i>
<u>Interview Facilities Page</u>	HRS_VENUE_PG	Maintain information about interview venues.

### Interview Facilities Page

Use the Interview Facilities page (HRS\_VENUE\_PG) to maintain information about interview venues.

Navigation:

**Recruiting > Administration > Interview Facilities**

This example illustrates the Interview Facilities page.

### Interview Facilities

**Venue Information**

Venue ID 3

Status Active

Description Halcyon Building Boardroom

\*Email hbb@oraclesample.com

Location 15 Porter Road  
Riverside  
New Granger

Directions Use Appleford Bus service Number 67 to stop 245 (Halworks).  
Halcyon Building is accessed by using the travelator from the Bus Stop.  
Please report to reception on entering the building for further directions.  
Buses travel at 20 minute intervals between 7AM and 11PM on weekdays.

Notes Order Beverages from ext 3765 at any time

Room Details Room seats 7 people in a circle.

Attachments					Personalize   Find   View All	First	Last
File Name	Description	Last Updated	Last Updated By	Delete			
1 halcyon.pdf	halcyon.pdf	06/16/2009 8:45PM	SAMPLE				

[Add Attachment](#)

### Venue Information

<b>Field or Control</b>	<b>Description</b>
<b>Venue ID</b>	Displays a unique identifier that the system assigns when you create the venue.
<b>Status</b>	Select <i>Active</i> or <i>Inactive</i> to indicate whether the venue is available for use on the Interview Schedule page.
<b>Description</b>	Enter the description that users see when selecting this venue to use for an interview.
<b>Email</b>	The email address specified is informational only.



<b>Field or Control</b>	<b>Description</b>
<b>Location</b>	<p>Enter the specific location of the venue. When a recruiter adds a venue to an interview, the system copies the location information to the interview schedule. If the recruiter modifies the location text in the actual interview schedule, the changes are replicated to the venue definition.</p> <p>Interviewers can see the location information on the Interview Calendar page.</p> <p>Applicants can see the location information on the Interview Detail page in Candidate Gateway. Applicants access the Interview Details page using the interview notification link that the system generates if the Notify Applicant check box is selected when the interview is submitted.</p> <p>Under partial calendar information, location information is also included in the iCalendar attachment that the system sends.</p>
<b>Directions</b>	<p>Enter directions to the venue.</p> <p>Applicants can see the directions on the Interview Detail page in Candidate Gateway. Applicants access this page using the interview notification link that the system generates if the Notify Applicant check box is selected when the interview is submitted.</p>
<b>Notes</b>	<p>Enter any additional notes about the venue. Information in this field does not appear on the Interview Schedule page.</p> <p>However, users who are scheduling interviews can access the Interview Facilities page from the Interview Schedule page if they want to review this information.</p>
<b>Room Details</b>	<p>Enter any additional room details about the venue. Information in this field does not appear on the Interview Schedule page.</p> <p>However, users who are scheduling interviews can access the Interview Facilities page from the Interview Schedule page if they want to review this information.</p>

## Attachments

Upload any useful attachments such as maps or room-specific instructions. The attachments grid includes a link to the document along with information about who uploaded the file and when it was uploaded.

Attachments do not appear on the Interview Schedule page. However, users who are scheduling interviews can access the Interview Facilities page from the Interview Schedule page if they want to review this information.

## Scheduling and Managing Interviews

This topic provides overviews of applicant interviews, calendar integration options, and interview letters and notifications. This topic then discusses how to schedule and manage interviews.

### Pages Used to Schedule and Manage Applicant Interviews

<i>Page Name</i>	<i>Definition Name</i>	<i>Usage</i>
<u>Manage Interviews Page</u>	HRS_INT_SUMMARY	Review summary data about existing interviews and evaluations, and enter a final recommendation for an interview.
<u>Select Job Opening for Interview Page</u>	HRS_APP_ACTION	Select the job opening for which you are scheduling an interview for an applicant.
<u>Interview Schedule Page</u>	HRS_INT_SCHED	Schedule applicant interviews.
<u>Interview Schedule Comments Page</u>	HRS_RCRTR_CMTS_SP HRS_REC_APP_CMT_SP	Add a comment. Applicant comments are displayed on the interview detail page in Candidate Gateway. Interviewer comments are displayed to interviewers on the Interview Schedule page.
<u>Interview Schedule (Participant Availability) Page</u>	HRS_APP_AVAIL_SP HRS_INT_AVAIL_SP	View the current interview schedule for an applicant or interviewer. The system does not check external calendar systems for availability. Availability is based only on other interview schedules in the PeopleSoft system.
<u>Interview Notes Page</u>	HRS_INT_NOTE_PG	Maintain interview-related notes.
<u>Interview Request Page</u>	HRS_INT_MTG_REQ_PG	Review and optionally modify notification text to be sent to interviewers and applicants.  This page is relevant only under partial calendar integration.
<u>Interview List Page</u>	HRS_VW_ALL_INT_PG	View a read-only summary of data from the Interview Schedule page.

### Understanding Applicant Interviews

You can schedule applicant interviews at any time in the recruiting process, whether or not the applicant is associated with a job opening. To schedule and manage applicant interviews, use the Manage Interviews action.

## The Manage Interviews Action

The Manage Interviews action provides access to two pages:

- [Interview Schedule Page](#)

Use this page to enter and maintain detailed information about interviews, including the interview status, type, date, time, location, and a list of interviewers. The Interview Schedule page shows data for one or more applicants for a single job opening. You can also schedule interviews for applications without a job opening.

- [Manage Interviews Page](#)

Recruiters use this page to view summary information about an applicant's interviews and interview evaluations for a particular job opening (or application with no job opening) and to enter the final recommendation regarding the next step for the applicant.

This page is similar to the [Manage Application Page: Interview Tab](#), except that the Manage Interviews page lets you enter a final recommendation directly on the page rather than in a modal dialog box.

When you perform the Manage Interviews action, the Manage Interviews page appears if the action was initiated for a single applicant who already has an interview schedule. If the applicant does not yet have an interview schedule, or if you perform the action for multiple applicants, the context is not appropriate for the Manage Interviews page, and the Interview Schedule page appears instead.

This diagram illustrates which page appears when you perform the Manage Interviews action.

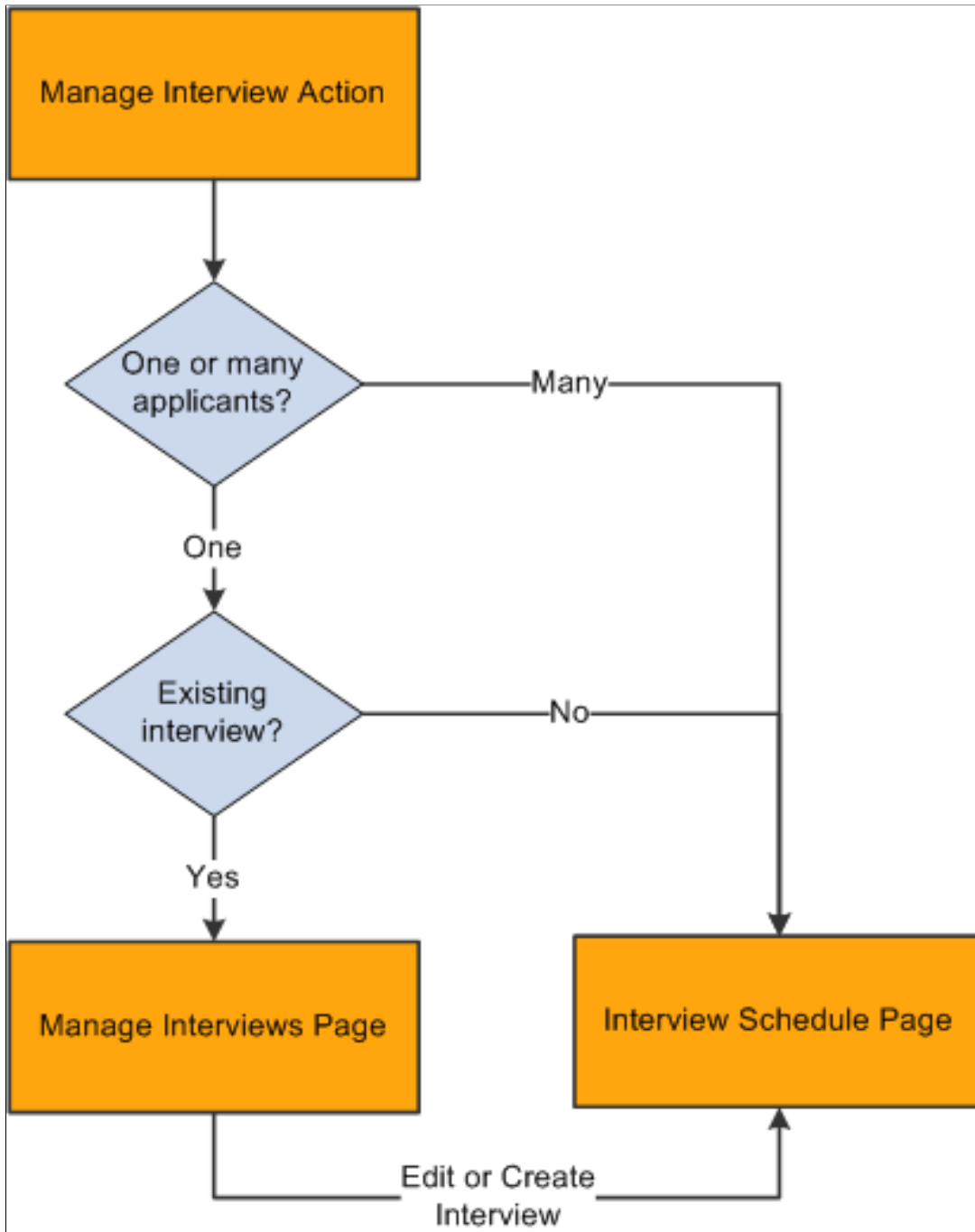

To initiate the Manage Interviews action, click the Manage Interviews icon (for a single application) or perform the Manage Interviews group action (for multiple applications) in these locations:

- Manage Job Opening page
- Manage Applicant page (no group action available)
- Manage Application (no group action available)
- Search Applications page

This page can list applications for more than one job opening, but the Manage Interviews action displays an error if the selected rows do not all have the same job opening ID.

## Interview Summary Pages

The system provides additional options for viewing read-only summary information about interviews.

- For an applicant-centered interview summary, use the [Manage Applicant page: Applicant Activity Tab: Interview Schedule/Evaluation Section](#).
- For a job-centered interview summary, access the Manage Job Opening page and click the Interviews toolbar button to access the [Interview Summary Page](#).
- For a summary of the interviews that you are currently working with on the Interview Schedule page, click the View All Interviews button to access the [Interview List Page](#).

The length of the Interview Schedule page can make it difficult to review data for more than one interview, so this summary provides a convenient way to double-check times and interviewers as you schedule multiple interviews.

- To view your personal interview calendar (for interviews where you are a participant), use the self-service [Interview Calendar Page](#).
- To view a list of job openings or applicants where you are on the interview team, use the self-service [Interview Team Schedule Page](#).

## Flexible Recruiting Processes

If a job opening is governed by a flexible recruiting process, that process controls the availability of the Manage Interviews action. Availability can vary depending on the user's role and the applicant's current disposition.

The system hides the Manage Interviews icon for specific rows where the action is not available. The system does not remove the action from the Group Actions menu, but it prevents you from continuing with a group action if your selection includes rows where the action is not available.

The flexible recruiting process is a usability tool, not a security layer. Although it controls the availability of the Manage Interviews action, it does not prevent users from accessing the Interview Schedule page using links and buttons on the interview summary pages such as the interview calendar.

## Understanding Calendar Integration Options

This overview describes calendar integration for interviews.

### Integration Basics

To activate calendar integration for interviews in Talent Acquisition Manager, use the [Recruiting Installation - General Page](#), where you select the level of calendar integration for your system:

- *Partial* integration sends interview schedules to applicants and interviewers as iCalendar attachments.

An email with an iCalendar attachment is sent only when the user explicitly chooses to send a notification or when the interview status changes to *Confirmed*. The email with the attachment is sent in addition to a standard text-only PeopleSoft email notification.

The iCalendar file contains only the information that is required for creating a meeting request in an external calendar. Participant can import the iCalendar meeting request into their own calendar system. This is a one-way integration, so Talent Acquisition Manager does not get any response back from the participant.

- *None* indicates that you do not want to integrate with external calendaring systems.

Users can still choose to send notifications to applicants and interviewers, but the notifications are standard text-only PeopleSoft notifications.

- The *Full* option is no longer supported.

## Partial Calendar Integration

Under partial calendar integration, Notify check boxes for the applicant and the interviewers enable the user to send notifications to interview participants. If these check boxes are selected at the time an interview is submitted, confirmed, cancelled, the system sends each recipient an email with a formatted iCalendar attachment.

Recipients can open the iCalendar attachment in their calendaring software to add, modify, or remove the meeting request entry from their calendar.

Under partial calendar integration, the email with the iCalendar attachment is sent in addition to a standard text-only PeopleSoft email notification. When scheduling an interview on the Interview Schedule page, a user can preview and modify the text of this notification.

## Understanding Interview Letters and Notifications

This overview describes interview letters and notifications

### Interview Letters

When you enter interview information, you can optionally generate template-based interview letters to send to the applicant.

On an applicant's overall interview schedule, the sections for individual interviews include a group box to use for producing an interview-specific letter or for marking the interview for inclusion in a consolidated interview letter. A separate Consolidated Interview Letter section appears after the last interview in the applicant's schedule, and you use this section to produce the consolidated letter.

The same letter templates are available for selection for individual interview letters and the consolidated interview letter. The delivered templates are valid for both scenarios because the letters list interviews in a table format even there is only one interview.

When the system generates interview letters, it also creates a contact note for the applicant.

## Letter Generation

Talent Acquisition Manager uses Oracle Business Intelligence Publisher (BI Publisher) to generate recruitment letters, including interview letters.

You can generate interview letters manually on the Interview Schedule page. If you do not generate letters manually, then when you submit the interview schedule, individual interview letters that you defined but did not generate are added to the next run of the HRS Letter Generation (HRSLETTR) Application Engine process. This process generates all queued letters in batch.

---

**Important!** Only individual interview letters can be generated in batch. Consolidated interview letters must be generated manually on the Interview Schedule page. This behavior ensures that there are no changes to the list of interviews to be included between the time you mark interviews for inclusion and the time the letter is generated.

---

To generate a letter from the interview schedule, use these links, which appear both for individual interviews and for the consolidated interview letter:

- **Generate Letter**

Click this link to generate an interview letter based on the selected template. The letter opens in a new browser window where you can review and optionally update it. If you make changes, save the modified letter to a local drive so that you can upload the revised version.

When you generate the letter, the system enters the current date in the **Date Printed** field and generates a contact note for the applicant.

- **Email Applicant**

Click this link to access the Send Correspondence page. If you manually generated an interview letter using the Generate Letter link, then the Send Correspondence page includes the interview letter as a default attachment to the email. When you send the correspondence, the system generates a contact note for the applicant. The contact note includes any attachments that were in the email.

- **Upload Letter**

Click this link to upload a letter file from a local drive. Typically, you are uploading a modified copy of the letter that you created by clicking the **Generate Letter** link.

When you upload a letter, the system creates a contact note for the applicant. The contact note includes the interview letter attachment.

These links become available for a new interview only after you save the interview. The links remain available even if you make changes to the interview, but the letter generation process uses the saved data, so remember to save changes to ensure that the letter includes the most current information.

## Interview Notifications

Under partial calendar integration or no calendar integration, the Interview Schedule page includes Notify check boxes for the applicant and the interviewers. When a user submits, resubmits, confirms, or cancels an interview, the system sends notifications to participants whose Notify check box is selected. Any time the system sends a notification to an applicant, it also creates a contact note in the applicant's record.

---

**Note:** The system sends notifications only when the Notify check box is selected.

---

The following table summarizes the types of notifications that the selected interview participants receive under each integration option:

<b>Notification Type</b>	<b>Full</b>	<b>Partial</b>	<b>None</b>
Email with iCalendar Attachment (applicant and interviewers)	Not applicable	Yes	No
Text-only email notification (applicant and interviewers)	Not applicable	Yes	Yes
Candidate Gateway notification (applicant only)	Not applicable	Yes	Yes

In Candidate Gateway, notifications appear on the My Notifications page. The applicant can click the interview notification to access more complete interview details.

If an applicant already has a Candidate Gateway notification for the interview, and a recruiting user makes a change and sends a new notification, the system does not create an additional Candidate Gateway notification. Instead, the detail page that is accessed from the notification shows the updated interview data. If the applicant deleted the previous Candidate Gateway interview notification, then the notification process creates a new one.

When a participant's appointment status changes, the system sends a notification to the user who created the interview.

## Notification Templates

To provide appropriate notification text for different scenarios, the system uses different notification templates depending on the action that triggered the notification and depending on whether the interview is for an application that is associated with a job opening or for an application with no job opening.

The following table lists the notification templates that the system uses to send notifications to interviewers:

<b>Recipient</b>	<b>User Action</b>	<b>Job Opening or None</b>	<b>Interviewer Notification</b>
Interviewer	Submit or resubmit interview	Job opening	HRS_INTVW_SCHED_TEAM
Interviewer	Submit or resubmit interview	No job opening	HRS_INTVW_SCHED_TEAM_NOJO
Interviewer	Cancel interview	Job opening	HRS_INTVWSCHED_TEAM_CANCEL



<b><i>Recipient</i></b>	<b><i>User Action</i></b>	<b><i>Job Opening or None</i></b>	<b><i>Interviewer Notification</i></b>
Interviewer	Cancel interview	No job opening	HRS_INTVWSCHED_NOJO_CANCEL
Applicant	Submit or resubmit interview	Job opening	HRS_INTVWSCHED_APPL
Applicant	Submit or resubmit interview	No job opening	HRS_INTVWSCHED_APPL_NOJO
Applicant	Cancel interview	Job opening	HRS_INTVW_APP_CANCEL
Applicant	Cancel interview	No job opening	HRS_INTVW_CANCEL_APP_NOJO

## **Related Links**

[Sending Correspondence and Recruitment Letters](#)

## **Manage Interviews Page**

Use the Manage Interviews page (HRS\_INT\_SUMMARY) to review summary data about existing interviews and evaluations and to enter a final recommendation for an interview.

Navigation:

Initiate the Manage Interviews action for a single applicant who has at least one existing interview. This action is available on the following pages:

- Manage Job Opening page: Applicant tab
- Manage Applicant page: Applicant Activity page: Current Status section
- Search Applications
- Manage Application

This example illustrates the Manage Interviews page.

Manage Interviews
Personalize

Applicant Name Mayuri Reddy  
 Applicant ID 500229  
 Job Posting Title Office Assistant  
 Job Code N00048 (Front Office Assistant)

Job Opening ID 300223  
 Job Opening Status 010 Open  
 Business Unit NSWBU (Swiss Hotels)  
 Position Number N0000007 (Office Assistant)

**Interview Summary** ?

Select	Date	Start Time	End Time	Time Zone	Location	Submitted	Final Recommendation	
<input type="radio"/>	02/01/2013	9:00AM	10:00AM	PST	548 Sydweigh Boulevard, San Francisco	✓	005 Interview	
<input checked="" type="radio"/>	01/17/2013	9:00AM	10:00AM	PST	548 Sydweigh Boulevard, San Francisco	✓	005 Interview	

**Interview Details** ?

Date 01/17/2013  
 Start Time 9:00AM PST  
 End Time 10:00AM PST  
 Location 548 Sydweigh Boulevard, San Francisco  
 Submitted Yes

Edit Interview Schedule

**Final Recommendation** ?

Final Recommendation

Reason

Average Score 8

**Interview Evaluations** ?

Name	Interview Rating	Interview Type	Recommendation	Score	Action
Jake Oglevy		Campus		0.000	Evaluate Applicant
Betty Locherty	Excellent	Campus	020 Make Offer	8.000	Edit Evaluation

### Toolbar

<b>Field or Control</b>	<b>Description</b>
<b>Save</b>	Click to save changes to the <b>Final Recommendation</b> and <b>Reason</b> fields.
<b>Return</b>	Click to return to the page where you initiated the Manage Interviews action.

### Header

The header area of this page displays identifying information about the applicant and about the job opening for which the applicant has interviewed. This page requires the context of a single applicant and a single job opening (or an application without a job opening).

### Interview Summary

This grid lists all of the applicant’s interviews for the specified job opening.

<b>Field or Control</b>	<b>Description</b>
<b>Select</b>	Select the interview to be displayed in the Interview Details section of the page.

<b>Field or Control</b>	<b>Description</b>
<b>Date</b>	Displays the interview date.
<b>Start Time, End Time, and Time Zone</b>	Displays the interview time in the time zone specified on the Interview Schedule page.
<b>Location</b>	Displays the interview location.
<b>Submitted</b>	Displays a check mark if the interview has been submitted. If the interview has not been saved as a draft but has not been submitted, this field is blank.
<b>Final Recommendation</b>	<p>Displays the final recommendation as entered in the Interview Details section of this page.</p> <p>This field is initially blank for unsubmitted interviews. As delivered, the default value for newly submitted interviews is <i>005 Interview</i>. This default is configured on the <a href="#">Recruiting Status Area Page</a>.</p>

## Interview Details

This section shows detailed information about the interview selected in the summary grid. The summary information from the grid is repeated in the details section.

<b>Field or Control</b>	<b>Description</b>
<b>Edit Interview Details</b>	Click to access the <a href="#">Interview Schedule Page</a> , where you can review and edit complete information about the applicant's interviews for the specified job opening.

## Final Recommendation

<b>Field or Control</b>	<b>Description</b>
<b>Final Recommendation</b>	<p>The values in this drop-down list box are the statuses configured for the Interview status area on the <a href="#">Recruiting Status and Reason Page</a>.</p> <p>This field is initially blank for unsubmitted interviews. When the interview is submitted, the default status is applied. As delivered, this default status is <i>005 Interview</i>. If you use the delivered status change effects, and the applicant is currently in a pre-interview disposition, the creation of a new interview request with this status changes the applicant's disposition to <i>Interview</i>.</p> <p>When entering a final recommendation for a completed interview, choose a status that indicates the recommended next step in the recruiting process. Delivered options include <i>020 Make Offer</i>, <i>100 Hold</i>, <i>110 Reject</i>, <i>120 Withdrawn</i>, and <i>130 Withdrawn Application</i>. Saving changes to this field may trigger additional changes to the applicant's disposition, depending on status change effects configuration.</p>
<b>Reason</b>	<p>Optionally, select a reason for assigning the selected final recommendation. Values are available only if the status entered in the <b>Final Recommendation</b> field has associated reasons.</p>
<b>Average Score</b>	<p>Displays the average score from all submitted interview evaluations for this interview. Unsubmitted evaluations do not affect this calculation.</p>

## Interview Evaluations

After an interview's date and time have passed, the system automatically adds all scheduled interviewers to this grid.

<b>Field or Control</b>	<b>Description</b>
<b>Name</b>	<p>Displays the name of the evaluator.</p>
<b>Interview Rating</b>	<p>Displays the overall rating given by the evaluator. Values come from the rating scale associated with the interview evaluation template for the job opening.</p>

<b><i>Field or Control</i></b>	<b><i>Description</i></b>
<b>Interview Type</b>	Displays the interview type as entered on the Interview Evaluation page. This can differ from the interview type entered on the Interview Schedule page.
<b>Recommendation</b>	Displays the evaluator's recommendation. The values are the same as those available for the <b>Final Recommendation</b> field.
<b>Score</b>	Displays the total score for the evaluation. This is the sum of the scores for each evaluation category. The evaluation categories and the points associated with each rating on the rating scale all come from the interview evaluation template for the job opening.

<b>Field or Control</b>	<b>Description</b>
<b>Action</b>	<p>Displays text that indicates the status of the evaluation. When appropriate, the Action column text is a link that the user clicks to access the Interview Evaluation page. Values in this column include:</p> <ul style="list-style-type: none"> <li>• <i>Evaluate Applicant:</i> This appears when the evaluation has not yet been started. <p>This is an active link only for an evaluator's own evaluation. Clicking the link displays the Interview Evaluation page, where the evaluator can begin the evaluation.</p> </li> <li>• <i>Complete Evaluation:</i> This appears when the evaluation has been saved, but not yet submitted. <p>This is an active link only for an evaluator's own evaluation. Clicking the link displays the Interview Evaluation page, where the evaluator can continue to work on the evaluation.</p> </li> <li>• <i>View Evaluation:</i> This appears when the evaluation has been submitted. <p>This link is active regardless of who created the evaluation. Clicking the link displays the Interview Evaluation page in read-only mode.</p> </li> <li>• <i>Edit Evaluation:</i> Administrators see this instead of <i>View Evaluation</i> if you enabled administrator evaluation edits by selecting <i>Yes</i> in the Administrator Evaluation Edit field on the <a href="#">Recruiting Installation – Applicants Page</a>. <p>Clicking this link displays the Interview Evaluation page, but in this mode, the Save and Submit Evaluation buttons are replaced by buttons that the administrator can use to edit, delete, or send back the completed evaluation.</p> </li> </ul>
<b>Create New Evaluation</b>	Click this link to access the Interview Evaluation page to create a new evaluation.

## Create New Interview Schedule

<i>Field or Control</i>	<i>Description</i>
<b>Create New Interview Schedule</b>	Click to access the Interview Schedule page. The system adds a new blank interview section to the schedule when it opens the page.

## Select Job Opening for Interview Page

Use the Select Job Opening for Interview page (HRS\_APP\_ACTION) to select the job opening for which you are scheduling an interview for an applicant. This page appears when an applicant is associated with multiple job openings and you create a new interview from the Manage Applicant page, where the button for creating a new interview does not have the context of a job opening.

Navigation:

If an applicant has multiple recruiting records, this page appears when you click the **Create Interview** button on the Manage Applicant page: Applicant Activity tab: Interview Schedule/Evaluation section.

This example illustrates the Select Job Opening for Interview page.

### Select Job Opening for Job Interview

Applicant				
Name	Roslyn Patty	Preferred Contact	None	
Applicant ID	500262	Phone	578/479-2367	
Applicant Type	External Applicant	Email	roslyn.patty@oraclesample.com	
Status	010 Active	Address		

Select a Job Opening				
Select	Job Opening	Job Opening ID	Disposition	Last Updated
<input type="radio"/>	Administrative Support Supervisor	504003	100 Hold	09/04/2012 3:56PM
<input type="radio"/>	Billing Manager - Medical Claims	504024	010 Applied	07/27/2012 11:24AM
<input type="radio"/>	General Office Clerk	504001	060 Interview	07/27/2012 11:42AM
<input type="radio"/>	Executive Services Administrator	504004	020 Reviewed	09/04/2012 12:00AM

Continue
[Return to Previous Page](#)

<i>Field or Control</i>	<i>Description</i>
<b>Select a Job Opening</b>	This grid lists all of the applicant's job openings. Select the job opening for which you are creating an interview, then click the Continue button to continue to the Interview Schedule page.

## Interview Schedule Page

Use the Interview Schedule page (HRS\_INT\_SCHED) to schedule applicant interviews.

Navigation:

Initiate the Manage Interviews action for a group of applicants or for a single applicant with no existing interviews. This action is available on the following pages:

- Manage Job Opening page: Applicant tab
- Manage Applicant page: Applicant Activity page: Current Status section
- Search Applications
- Manage Application

You can also access this page using buttons and links on other pages throughout the system, including the following:

- Manage Interviews page
- Manage Applicant page: Applicant Activity tab: Interview Schedule/Evaluation section
- Select Job Opening for Interview page
- Interview Calendar page
- Interview Team Schedule page

This is the first of three examples illustrating the Interview Schedule page. This example shows the general structure of the page. The page has collapsible sections for each applicant. Within the applicant sections, there are collapsible sections for each interview, followed by a section for setting up a consolidated interview letter.

The screenshot displays the 'Interview Schedule' page for a job opening. At the top, there are navigation buttons: 'Submit', 'Save as Draft', and 'Return'. The page header includes 'Personalize' and job details: Job Opening ID 30005, Job Opening Status 010 Open, Submitted No, Business Unit GBIBU (Global Business Institute BU), and Job Posting Title Analyst-Business.

Two applicant sections are shown:

- Francine Felkner (3):** Applicant ID 1006, Applicant Type External Applicant, Preferred Contact Not Specified. This section contains three interviews:
  - Interview 1 - 01/25/2013 10:00 AM To 10:30 AM PST
  - Interview 2 - 02/04/2013 9:00 AM To 9:45 AM PST
  - Interview 3 - 02/11/2013 9:00 AM To 9:30 AM PST
 Below the interviews are buttons for 'Consolidated Interview Letter' and 'Add Interview'.
- Geraldine Gates (1):** Applicant ID 1007, Applicant Type External Applicant, Preferred Contact Not Specified. This section contains one interview:
  - Interview 1 - 02/05/2013 10:00 AM To 10:30 AM PST
 Below the interview are buttons for 'Consolidated Interview Letter' and 'Add Interview'.

At the bottom of the applicant sections, there are buttons for 'View All Interviews', 'Expand All', and 'Collapse All'. The footer includes 'Submit', 'Save as Draft', 'Return', and 'Top of Page'.



This is the second of three examples illustrating the Interview Schedule page.

**Geraldine Gates (1)**  
 Applicant ID: 1007  
 Applicant Type: External Applicant  
 Preferred Contact: Not Specified

**Interview 1 - 01/25/2013 9:30 AM To 10:00 AM PST**

Date: 01/25/2013  
 Interview Status: Unconfirmed  
 Initiator: Betty Locherty  
 Start Time: 9:30AM  
 Interview Type: Inhouse2  
 End Time: 10:00AM  
 Applicant Response: None  
 Time Zone: PST

**Interviewers**

Interviewer ID	Interviewer Name	Date	Start Time	End Time	Time Zone	Response	Comments	Availability	Notify
KU0003	Jean Parsons	01/25/2013	9:30AM	10:00AM	PST				<input type="checkbox"/>
KU0007	Betty Locherty	01/25/2013	9:30AM	10:00AM	PST				<input type="checkbox"/>

**Venue Information**

Venue: Conference Room 1  
 Location: Room 1, Ground Floor, Global Business Centre, 548 Sydweigh Boulevard, San Francisco

**Interview Materials**

Subject	Note Date	Author
Interview Notes	01/21/2013	Betty Locherty

File Name	Description	Added By	Date Added
interview_script.doc	Interview script	Betty Locherty	02/03/2013

This is the third of three examples illustrating the Interview Schedule page.

**Preview/Edit Meeting Request**

Buttons: Interviewer Meeting Request, Applicant Meeting Request, Cancel Interview

**Letter**

Letter: [Dropdown]  
 Date Printed: [Date Picker]  
 Include in Consolidated Letter  
 Buttons: Generate Letter, Email Applicant, Upload Letter

**Consolidated Interview Letter**

Letter: [Dropdown] Date Printed: [Date Picker]  
 Select All Interviews  Deselect All Interviews  Exclude Past Dated Interviews  
 Buttons: Generate Letter, Email Applicant, Upload Letter

Buttons: Add Interview, View All Interviews, Expand All, Collapse All

Footer: Submit, Save as Draft, Return, Top of Page

### Collapsible Sections on the Interview Schedule Page

Links at the bottom of the page enable you to expand or collapse all sections with a single click.

<b>Field or Control</b>	<b>Description</b>
<b>Applicant</b>	The Interview Schedule page always shows interviews for a single job opening, but depending on how you access the Interview Schedule page, it can show schedules for one applicant or multiple applicants. The page includes a collapsible section for each included applicant, even if there is only one.

<b>Field or Control</b>	<b>Description</b>
<b>Interview</b>	Within the section for a single applicant, there are collapsible sections for each scheduled interview. In this context, a single interview refers to a single block of time that is associated with one or more interviewers. To schedule separate time slots for different interviewers, recruiters need to set up multiple interviews.
<b>Consolidated Interview Letter</b>	For each applicant whose schedule appears on the page, the final collapsible section, after all of the interview sections, is for sending the applicant a consolidated interview letter. This is a letter that provides information about multiple interviews. The individual interview sections have separate page elements that you can use to mark them for inclusion in the consolidated letter.  See <a href="#">Understanding Interview Letters and Notifications</a> .

### Page Elements That Vary According to the Integration Option

The following table lists the page elements that are hidden under each integration option:

<b>Page Element</b>	<b>No Calendar Integration</b>	<b>Partial Calendar Integration</b>
Interview Status field (Interview section)	Hidden	Visible
Scheduler Status field (Interview section)	Hidden	Hidden
Notify check boxes for the applicant, for individual interviewers, and for the interview team (Interview section)	Visible	Visible
Preview/Edit Meeting Request group box (Interview section)	Hidden	Visible
Launch Scheduler button (Applicant section)	Hidden	Hidden

**Note:** The preceding page illustrations show the Interview Schedule page as it appears under partial calendar integration, where everything is visible except for the Scheduler Status field and the Launch Scheduler link.

## Toolbar

<b>Field or Control</b>	<b>Description</b>
<b>Submit</b>	<p>Click when you have finished entering the interview schedule.</p> <p>Submitting the interview generates notifications for the participants whose Notify check boxes are selected.</p> <p>If the interview was not previously submitted, submitting also sets the <b>Final Recommendation</b> field (which is not shown on the Interview Schedule page) to the default status for the Interview status area, <i>Interview</i>. If you use the system's delivered statuses and status change effects, and the applicant is currently in a pre-interview disposition, this status change in turn updates the applicant's disposition to <i>060 Interview</i>.</p> <hr/> <p><b>Note:</b> The interview status that is set when you submit an interview does not appear on this page. On the pages where it is visible, it is labeled <b>Final Recommendation</b>.</p>
<b>Save as Draft</b>	Click to save your changes without generating notifications, updating the applicant's disposition, or creating calendar meetings.
<b>Return</b>	Click to discard any unsaved changes and return to the previous page.

## Applicant Section

The system displays a collapsible section for each applicant for whom you are scheduling interviews. The section title shows the applicant's name followed by the number of interviews that exist for the applicant.

<b>Field or Control</b>	<b>Description</b>
Applicant ID	Displays the applicant's unique identifier.
<b>Applicant Type</b>	Displays the applicant type, either <i>Employee</i> , <i>External Applicant</i> , or <i>Non-Employee</i> .



<b>Field or Control</b>	<b>Description</b>
<b>Preferred Contact</b>	Displays the applicant's preferred contact method. Refer to this field when considering how to notify the applicant of the interview.

## Interview Section

For each applicant included on the page, the system displays one or more collapsible sections representing separate interview times. The section title uses the format *Interview <#> – <date and time>*.



<b>Field or Control</b>	<b>Description</b>
<b>Date</b>	Enter the date on which the interview is to take place.
<b>Start Time, End Time, and Time Zone</b>	<p>Enter the start and end times for the applicant's interview. The default time zone is the recruiter's own time zone.</p> <p>This time applies to all interviewers. To schedule different interviewers at different times, create multiple interviews for the applicant.</p>

<b>Field or Control</b>	<b>Description</b>
<p><b>Interview Status</b></p>	<hr/> <p><b>Note:</b> This field appears only under partial calendar integration.</p> <hr/> <p>Values in this status field represent the stages of the interview process.</p> <p>These are the possible statuses:</p> <ul style="list-style-type: none"> <li>• <i>Unconfirmed</i> is the initial status for new and reinstated interviews.</li> <li>• <i>Scheduled</i> indicates that the meeting invitation has been sent.</li> <li>• <i>Confirmed</i> indicates that all participants have accepted the invitation.</li> <li>• <i>Completed</i> indicates that the interview has occurred and all interview evaluations are done.</li> </ul> <p>The Interview Evaluation Reminder (HRS_INT_EVAL) Application Engine process changes the interview status to <i>Completed</i> when all interview evaluations are complete for an interview in the past. Users can also manually put interviews in <i>Completed</i> status.</p> <p>See <a href="#">Finalizing Interviews and Sending Evaluation Reminders</a>.</p> <ul style="list-style-type: none"> <li>• <i>Cancelled</i> indicates that the interview was cancelled.</li> </ul> <p>All interview data for a cancelled interview is read-only.</p> <p>Users can cancel interviews by updating the status directly (though the change does not take effect until the changes are submitted), or they can click the <b>Cancel</b> button that appears at the end of each interview section.</p> <hr/> <p><b>Note:</b> This field is <i>not</i> associated with the Interview status area that is configured on the Statuses and Reasons page.</p> <hr/>
<p><b>Interview Type</b></p>	<p>Select one of the interview types that your organization defined on the <a href="#">Interview Types Page</a>. The specific values depend on how your organization chooses to classify interviews.</p>

<b>Field or Control</b>	<b>Description</b>
<b>Applicant Response</b>	Users can manually set the appointment status to <i>Accepted</i> , <i>Declined</i> , <i>None</i> (no response), or <i>Tentative</i> (tentatively accepted).
 <b>Applicant Comments</b>	Click to access the Interview Schedule Comments page where you can enter applicant-specific comments. These comments appear on the interview details page that the applicant sees in Candidate Gateway.
 <b>Applicant Availability</b>	<p>Click to access the Interview Schedule page, which displays all interview dates and times for the applicant.</p> <p>This page displays only interview data from the PeopleSoft system.</p>
<b>Initiator</b>	Displays the name of the user who originally created the interview.
<b>Notify Applicant</b>	<hr/> <p><b>Note:</b> This check box appears only under partial or no calendar integration.</p> <hr/> <p>By default, this check box is initially deselected. Select this check box to have an email notification sent to the applicant when the interview is submitted. Under partial calendar integration, the system sends both a standard notification email and a separate email with an iCalendar attachment.</p> <p>If the applicant is a registered user of Candidate Gateway, the system also sends a Candidate Gateway notification.</p>
<b>Notify Interview Team</b>	<hr/> <p><b>Note:</b> This check box appears only under partial or no calendar integration.</p> <hr/> <p>Select this check box to make the system select all of the Notify check boxes for individual interviewers.</p> <p>This check box is simply a data entry shortcut: the system does not use this setting to determine who should receive a notification. If you select the Notify Interview Team check box and then deselect the Notify check box for an individual interviewer, the Notify Interview Team check box remains selected, but the system does not send a notification the deselected interviewer.</p>

## Interviewers

Use the Interviewers grid to identify the interviewers who will participate in the interview. If the interview is for a job opening, this grid initially includes the interviewers from the job opening hiring team. Add or remove interviewers as needed.

<b>Field or Control</b>	<b>Description</b>
<b>Interviewer ID</b> and Interviewer Name	Identify interviewers by entering their employee IDs; the system then displays the interviewers' name.
<b>Date, Start Time, End Time, and Time Zone</b>	These fields display the date and time for the interview in the interviewer's own time zone. Every interviewer is scheduled for the entire block of time. To schedule different times for different interviewers, create additional interviews.
<b>Response</b>	Set the appointment status to <i>Accepted</i> , <i>Declined</i> , <i>None</i> (no response), or <i>Tentative</i> (tentatively accepted) manually.
 <b>Comments</b> (interviewer comments)	Click to access the Interview Schedule Comments page and enter interviewer-specific comments. If interviewer-specific comments exist, the interviewer sees a comments icon alongside the interview on the Interview Calendar page.
 <b>Availability</b> (interviewer availability)	Click the icon to access the Interview Schedule page, where you can view the interviewer's current interview schedule.  This page displays only interview data from the PeopleSoft system.
<b>Notify</b>	<hr/> <b>Note:</b> This check box appears only under partial or no calendar integration. <hr/> Select this check box to have an email notification sent to an individual interviewer when the interview is submitted, resubmitted, or cancelled. The system uses the email addresses from the interviewers' Personal Data records.
<b>Add Interviewer</b>	Click this link to add another row to the Interview Schedule grid.  Click the <b>Notify</b> check box for the new row if you want the system to send notifications to the newly added interviewer when you submit the interview.

## Venue Information

<b>Field or Control</b>	<b>Description</b>
<b>Venue</b>	In the <b>Venue</b> field, select a physical location for the interview.  The available values are those that you set up in the Interview Facilities page.
<b>&lt;Venue Email Address&gt;</b>	When you select a venue, its email address appears.
<b>Response</b>	You can use this field to track venue availability by manually setting the value to <i>Accepted</i> , <i>Declined</i> , <i>None</i> (no response), and <i>Tentative</i> (tentatively accepted).
<b>Location</b>	If there is location information in the venue definition, the system enters that location information here, replacing any existing location text. You can modify the location text, and any changes that you make are saved to the venue definition.  You can also enter location text without selecting a venue.
<b>Add/Edit Venue</b>	Click to access the <a href="#">Interview Facilities Page</a> , where you can modify venue details for the currently selected venue, or add a new venue.

## Interview Materials

<b>Field or Control</b>	<b>Description</b>
<b>Notes</b>	Use the <b>Notes</b> grid to add notes related to the interview. You can also add attachments to individual notes.  These notes are specific to the interview; they are not associated directly to either the job opening or the applicant.



<b>Field or Control</b>	<b>Description</b>
<b>Attachments</b>	<p>Use the <b>Attachments</b> grid to attach external documents, such as interview scripts, to the interview schedule.</p> <p>Click the <b>Add Attachment</b> link to add file attachments to the grid; the system prompts you to identify the file to be uploaded.</p> <p>When a file is uploaded, the default description is the file name. You can modify this description until you save or submit the interview, at which point it becomes read-only.</p> <p>To view an existing attachment, click its file name. The attachment opens in a new window.</p>
<b>Load Job Opening Attachment and Load Job Opening Notes</b>	<p>Click these links to copy selected attachments and notes from the job opening to the interview. Job opening attachments and notes appear on the <a href="#">Manage Job Opening Page: Activity &amp; Attachments Tab</a>. Job opening attachments and notes are associated with specific audiences (<i>Private</i>, <i>Public</i>, or <i>Interview</i>), and when you load job opening attachments or notes into the interview, the system copies only the notes and attachments where the audience is <i>Interview</i>.</p>

## Preview/Edit Meeting Request

Use the links in this section to access the Interview Request page, where you can personalize the text of the meeting invitation for this interview.

---

**Note:** This section appears only under partial calendar integration.

---

<b>Field or Control</b>	<b>Description</b>
<b>Interviewer Meeting Request and Applicant Meeting Request</b>	<p>Click the appropriate link to review and optionally modify the text of notifications that the system sends to interviewers or applicants. You can also add attachments to the notification.</p> <p>As long as you do not make any changes to the default notification, changes that you make to the interview date, time and location are automatically reflected in the notification. However, after you save any changes to the default text, the system no longer makes any updates to the text.</p> <hr/> <p><b>Note:</b> If you change the interview date, time, or location after you modify the notification text, you must make any necessary changes to the notification text manually.</p> <hr/>

## Letter

<b>Field or Control</b>	<b>Description</b>
<b>Letter</b>	<p>Select a letter that you want to send to the applicant when an interview is scheduled.</p> <p>Talent Acquisition Manager uses Oracle Business Intelligence Publisher (BI Publisher) to generate recruitment letters. The templates that are available to use as interview letters are those from the HRS_INT_LET report definition</p>
<b>Date Printed</b>	<p>Displays the date that you printed the letter. The system populates the field when you click the Generate Letter link or when the letter is generated by the HRS Letter Generation batch process.</p>
<b>Include in Consolidated Letter</b>	<p>Select this check box to mark the interview for inclusion in a consolidated interview letter that lists all selected interviews. Selecting this check box makes the interview-specific fields and links inactive to suppress generation of a individual interview letter.</p> <p>If you select this check box for any interview, be sure to also generate the consolidated interview letter using the fields in the Consolidated Interview Letter section for the applicant.</p>
<b>Generate Letter</b>	<p>Click this link to generate the letter immediately. The system opens the generated letter in a new browser window, where you can print it or save it locally. Once the letter is generated, the Generate Letter link is no longer available and the letter is removed from the HRS Letter Generation batch process.</p> <p>When you generate a letter, the system creates a note on the Manage Applicant page: Notes tab. The letter is an attachment to the note.</p> <p>If you click the Email Applicant link after generating a letter, the system automatically attaches the generated letter to the email.</p>

<b>Field or Control</b>	<b>Description</b>
<b>Email Applicant</b>	<p>Click this link to display the Send Correspondence page, where you can send the applicant email. If you have generated or uploaded a letter, the Attachments grid on the Send Correspondence page includes the letter (although you can remove or replace it if you wish).</p> <p>After accessing the Send Correspondence page, enter the email subject and message, then send it to the applicant. When you send the email, the system creates a contact on the Manage Applicant page: Notes tab. The email attachments are saved as note attachments.</p> <p>See <a href="#">Sending Correspondence and Recruitment Letters</a>.</p>
<b>Upload Letter</b>	<p>Click this link to upload a saved letter as an attachment. Most commonly, you use this link to upload a modified version of the original generated letter. However, it is not necessary to generate a letter before uploading one.</p> <p>When you upload a letter, the system creates a note entry on the Manage Applicant page: Notes tab. The letter is an attachment to the note.</p> <p>If you click the Email Applicant link after generating a letter, the system automatically attaches the modified letter (rather than the original) to the email.</p>

### Buttons for Canceling and Reinstating Interviews

<b>Field or Control</b>	<b>Description</b>
<b>Cancel Interview</b>	<p>Click the <b>Cancel Interview</b> button, which appears only after an interview has been saved and submitted, to cancel the interview. When the interview is cancelled, the system changes the Interview Status to <i>Cancelled</i>, and all fields for the cancelled interview become read-only. Although these changes appear to occur immediately, you still need to submit or save the interview to complete the cancellation.</p> <p>Canceling an interview triggers notifications to participants whose Notify check boxes are selected.</p> <p>You cannot cancel interviews that have evaluations or where the applicant has proceeded past the <i>Interview</i> disposition.</p>

<b>Field or Control</b>	<b>Description</b>
<b>Reinstate Interview</b>	<p>After an interview is cancelled, the <b>Reinstate Interview</b> button replaces the <b>Cancel Interview</b> button. Click the <b>Reinstate Interview</b> button to change the interview status to <i>Unconfirmed</i> and make the interview fields editable again.</p> <p>The system will not allow you to submit a reinstated interview without first changing the interview date or time or adding or deleting at least one interviewer.</p>

### Consolidated Interview Letter

This group box appears after the last interview listed for the applicant. Use it to generate an interview letter that lists all of the interviews where the **Include in Consolidated Letter** check box is selected.

<b>Field or Control</b>	<b>Description</b>
<b>Letter, Date Printed, Generate Letter, Email Letter, and Upload Letter</b>	<p>Use these fields to select a template and generate a consolidated interview letter using that template. These page elements work similarly to the ones that appear for individual interviews, except that when you generate the letter, the system brings in data from multiple interviews.</p> <hr/> <p><b>Note:</b> Unlike individual interview letters, the consolidated interview letter cannot be generated by the HRS Letter Generation batch process. To produce a consolidated interview letter, you must use the Generate Letter link on this page.</p> <hr/>
<b>Select All Interviews and Deselect All Interviews</b>	<p>Click these buttons to select or deselect the <b>Include in Consolidated Letter</b> check box for all of the applicant's interviews that appear on the page.</p> <p>These buttons are simply a data entry shortcut. You can still change the settings for individual interviews after clicking these buttons.</p>

<b><i>Field or Control</i></b>	<b><i>Description</i></b>
<b>Exclude Past Dated Interviews</b>	<p>Select this check box before clicking the Select All Interviews button to prevent the button from selecting interviews on days before the current date. Interviews scheduled for the current date are not considered to be in the past.</p> <p>The Exclude Past Dated Interviews check box does <i>not</i> deselect past dated interviews, it just prevents them from being selected by the Select All Interviews button. For example, if you click the Select All Interviews button, then you subsequently select the Exclude Past Dated Interviews check box, any past dated interviews remain selected. To prevent those interviews from appearing in the consolidated interview letter, you need to deselect them either manually or by clicking the Deselect All Interviews button.</p>

## Applicant-Level Actions

These page elements appear at the end of each applicant section.

<b><i>Field or Control</i></b>	<b><i>Description</i></b>
<b>Add Interview</b>	Click this button, which appears once per applicant (at the bottom of the Interview Schedule page) to add an additional interview section for the applicant.

## View All Interviews

<b><i>Field or Control</i></b>	<b><i>Description</i></b>
<b>View All Interviews</b>	Click to access the <a href="#">Interview List Page</a> , which displays a read-only summary of the information on the Interview Schedule page.

## Interview Schedule Comments Page

Use the Interview Schedule Comments pages for interviewers (HRS\_RCRTR\_CMTS\_SP) and for applicants (HRS\_REC\_APP\_CMT\_SP) to add interview comments.

Navigation:

Click the **Comments** icon on the Interview Schedule page. There are separate **Comments** icons for applicant-specific comments and for interviewer-specific comments.

This example illustrates the Interview Schedule Comments page.

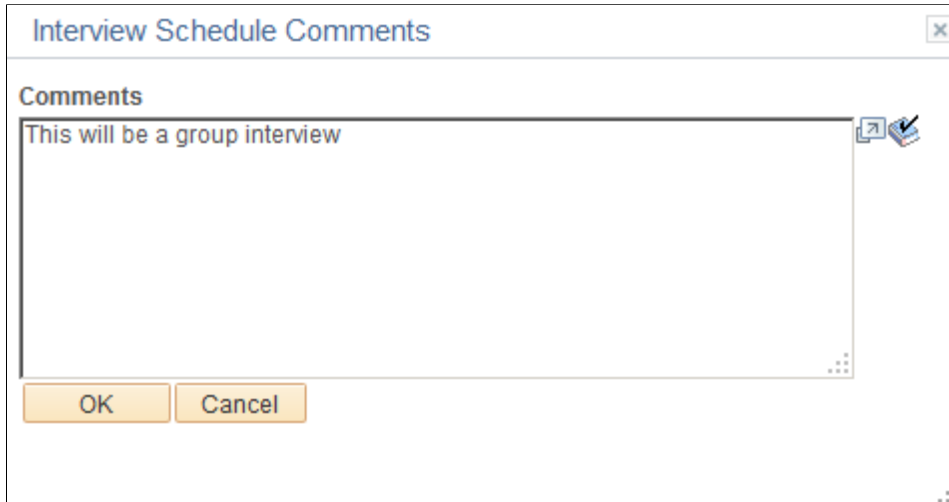

<i>Field or Control</i>	<i>Description</i>
<b>Comments</b>	Enter comments for either the applicant or for a specific interviewer.  Applicant comments are displayed on the interview detail page in Candidate Gateway.  Interviewer comments are displayed to interviewers on the Interview Schedule page.

## Interview Schedule (Participant Availability) Page

Use the Interview Schedule pages for applicants (HRS\_APP\_AVAIL\_SP) and interviewers (HRS\_INT\_AVAIL\_SP) to view the relevant interview schedules.

The system does not check external calendar systems for availability. Availability is based only on other interview schedules in the PeopleSoft system.

Navigation:

On the Interview Schedule page, click the **Availability** icon for the applicant or for a specific interviewer.

This example illustrates the Interview Schedule page that is used to view a participant's availability.

**Interview Schedule** ✕

Interview Date  [B]

Name Betty Locherty

Interviewer Availability				
Time Zone	Start Time	End Time	Applicant Name	Location
PST	9:30AM	10:00AM	Esther Evans	HQ750
PST	10:00AM	10:30AM	Francine Felkner	HQ750
PST	9:30AM	10:00AM	Geraldine Gates	HQ750

<b>Field or Control</b>	<b>Description</b>
<b>Interview Date</b>	Enter an interview date to see a list of interviews that the participant already has scheduled for that day.

## Interview Notes Page

Use the Interview Note page (HRS\_INT\_NOTE\_PG) to maintain interview-related notes.

Navigation:

- Click the **Add Note** button on the Interview Schedule page.
- Click the **Edit** icon for an existing note on the Interview Schedule page.

This example illustrates the Interview Notes page.

The screenshot shows a web interface titled "Interview Notes". It is divided into several sections:

- Applicant:** A header section containing "Applicant ID 1006" and "Applicant Name Francine Felkner".
- Note:** A section for creating a note, featuring:
  - "Note Date" with a date input field and a calendar icon.
  - "\*Subject" with a text input field.
  - "Details" with a larger text area and a "Details" icon.
- Attachments:** A section stating "No attachments have been added to this Note." with an "Add Attachment" button below it.
- Footer:** Two buttons: "Add Note" and "Cancel".

Interview notes include a date, a subject, option details, and optional attachments.

## Interview Request Page

Use the Interview Request page (HRS\_INT\_MTG\_REQ\_PG) to review and optionally modify notification text to be sent to interviewers and applicants.

Navigation:

Click the **Interviewer Meeting Request** button or the **Applicant Meeting Request** button on the Interview Schedule page.



This example illustrates the Interview Request page.

Schedule Interview

### Interview Request

---

**Message Type and Method**

Contact Method Not Specified      Meeting Request Type Interviewer Meeting Request

---

**Recipient Information**

To HCMGENUser1@ap6023fems.us.oracle.com, HCMGENUser1@ap6023fems.us.oracle.com...

---

**Sender Information**

From Betty Locherty

---

**Message**

Subject Interview Schedule for Francine Felkner on 01/25/2013 (MM/dd/yyyy)

Message You are scheduled to interview 1006 Francine Felkner on 01/25/2013 (MM/dd/yyyy) from 10:00 AM to 10:30 AM PST for Job Opening 30005 for Analyst-Business. You should have already been contacted about this interview by the hiring manager or recruiter. This message is just to confirm the scheduled interview.

The location entered into Online Recruiting for this interview is HQ750. If you are not sure of the address or exact location, please contact the person who scheduled the interview with you.

Access Public

---

**Attachment**

No Attachments have been added to this Message Request.

Add Attachment

---

[Return to Previous Page](#)

<b>Field or Control</b>	<b>Description</b>
<b>Subject and Message</b>	Review the default subject and text of the message and make any necessary modifications.
<b>Access</b>	Choose whether the contact note that is created for the notification is to be <i>Public</i> (the default) or <i>Private</i> . Anyone can view a public contact note; only the creator of the note can view a private note.
<b>Add Attachment</b>	You can optionally add attachments to the message. For example, you could attach a map to the interview venue.

**Note:** After you modify the notification text, the system no longer keeps the date and time in the notification synchronized with the actual interview date and time. If you change the interview date or time after modifying the notification text, be sure to return to this page to make the necessary updates.

## Interview List Page

Use the Interview List page (HRS\_VW\_ALL\_INT\_PG) to view a compact summary of data from the Interview Schedule page

Navigation:

Click the **View All Interviews** link on the Interview Schedule page.

This example illustrates the Interview List page.

[Schedule Interview](#)

### Interview List

Interview list for

**Applicant Name** Esther Evans

**Interview Details**

**Job Opening** 30005 Analyst-Business

**Description** 060 Interview

**Interview 1**

**Interviewers**

Name	Status	Interview Level	Time Zone	Date	Start Time	End Time
Jean Parsons	Unconfirmed	Inhouse2	PST	01/25/2013	9:30AM	10:00AM
Betty Locherty	Unconfirmed	Inhouse2	PST	01/25/2013	9:30AM	10:00AM

---

**Applicant Name** Geraldine Gates

**Interview Details**

**Job Opening** 30005 Analyst-Business

**Description** 060 Interview

**Interview 1**

**Interviewers**

Name	Status	Interview Level	Time Zone	Date	Start Time	End Time
Jean Parsons	Unconfirmed	Inhouse2	PST	01/25/2013	9:30AM	10:00AM
Betty Locherty	Unconfirmed	Inhouse2	PST	01/25/2013	9:30AM	10:00AM

[Return to Previous Page](#)

## Completing Interview Evaluations

This topic provides an overview of interview evaluations and discusses how to manage interview evaluations.

---

**Note:** Only administrators can update submitted evaluations.

---

## Pages Used to Complete Interview Evaluations

<i>Page Name</i>	<i>Definition Name</i>	<i>Usage</i>
<a href="#">Interview Evaluations (List) Page</a>	HRS_INT_EVAL_LST	Review and manage the evaluations that you are responsible for completing.
<a href="#">Interview Evaluation Page</a>	HRS_INT_EVAL	Create, update, or review interview evaluations.
<a href="#">Interview Evaluation Page (Read Only)</a>	HRS_VIEW_INT_EVAL	View a submitted evaluation.
<a href="#">Evaluation Rating Comments Page</a>	HRS_INT_EVAL_SEC	View an evaluator's comments for a specific evaluation category.

## Understanding Interview Evaluations

After an interview, interviewers enter their evaluations on the Interview Evaluation page. Interview evaluations are specific to the context of a particular job opening (or an application without a job opening).

### The Create Interview Evaluation Action

The Create Interview Evaluation action provides access to the Interview Evaluation page from these contexts:

- Manage Job Opening (also available as a group action)
- Manage Applicant
- Manage Application
- Search Applications

To invoke this action, select **Recruiting Actions** > **Create Interview Evaluation** from the Other Actions menu or, on the Manage Job Opening page, from the Group Actions menu.

### Summary Pages for Interview Evaluations

The following pages include summary grids showing evaluations that have been started or completed for an interview. These pages all include links for viewing existing evaluations and a Create New Evaluation button for adding additional evaluations:

- [Manage Interviews Page](#)
- [Manage Application Page: Interview Tab](#)

- [Manage Applicant page: Applicant Activity Tab: Interview Schedule/Evaluation Section](#).

An additional page, the self-service [Interview Evaluations \(List\) Page](#), includes a grid that lists only your own evaluations. It includes rows for all interviews where you are a participant, regardless of whether you have started the evaluation. Because this page lists evaluations for an interviewer rather than for a specific applicant, it does not provide a button for starting new evaluations.

## Flexible Recruiting Processes

If a job opening is governed by a flexible recruiting process, that process controls the availability of the Create Interview Evaluation action. Availability can vary depending on the user's role and the applicant's current disposition.

The system hides the Create Interview Evaluation action from the Other Actions menu for specific rows where the action is not available. The system does not remove the action from the Group Actions menu, but it prevents you from continuing with a group action if your selection includes rows where the action is not available.

The flexible recruiting process is a usability tool, not a security layer. It does not prevent users from accessing the Interview Evaluation page using links and buttons on the pages that list evaluations.

## Completing Evaluations

To complete an evaluation, evaluators assign ratings for individual evaluation categories, give an overall rating and recommendation, and enter any comments.

The evaluation categories that appear on the Interview Evaluation page come from the interview evaluation template that is associated with the job opening's recruitment template. The interview evaluation template also defines the rating scale and the points associated with each value on the rating scale.

When a user submit an interview evaluation, the system sends a notification to all of the recruiters and hiring managers for the job opening. Evaluators cannot make any further changes to submitted evaluations unless an administrator reverses the submission using Send Back functionality.

## Updating Submitted Applications

When you set up your recruiting system, you can give administrators the ability to edit, delete, and send back submitted interview evaluations. To do this, select *Yes* in the Administrator Evaluation Edit field on the [Recruiting Installation – Applicants Page](#).

When you grant administrators these additional privileges, administrators see an *Edit Evaluation* link rather than a *View Evaluation* link next to completed evaluations. Clicking this link displays the Interview Evaluation page, but in this mode, the administrator has the option to:

- Edit the completed evaluation.

When an administrator edits an evaluation, additional fields show who edited the evaluation and when it was edited. The administrator can also enter comments regarding the changes.

- Delete the completed evaluation.
- Send back the evaluation, an action that reverses the evaluation submission as if the original evaluator had saved it without submitting it.

## Interview Evaluations (List) Page

Use the Interview Evaluations list page (HRS\_INT\_EVAL\_LST) to review and manage the evaluations that you are responsible for completing.

Navigation:

**Self Service > Recruiting > Interview Evaluations**

This example illustrates the Interview Evaluations list page.

**Interview Evaluations**

Please complete interview evaluations for the applicants listed below. Select the link in the Action column to access an evaluation form. The list includes only applicants who were interviewed during the specified time period. To view other applicants, change the interview dates and then select the Refresh button.

Show Interviews Between  and

ID	Name	Interview Date	Start Time	Time Zone	Job	Interview Rating	Interview Type	Score	Action
1006	Francine Felkner	02/04/2013	9:00AM	PST	Analyst-Business	Excellent	Inhouse3	7.000	<a href="#">View Evaluation</a>
300129	Karla Beneffer	02/03/2013	9:00AM	PST	Radiologist - Burns Unit			0.000	<a href="#">Evaluate Applicant</a>
300137	David Davies	02/01/2013	9:00AM	PST	Radiologist - Burns Unit			0.000	<a href="#">Evaluate Applicant</a>
300132	Jacqueline Bertholt	01/31/2013	9:00AM	PST	Radiologist - Burns Unit			0.000	<a href="#">Evaluate Applicant</a>
300212	Dave Phelps	01/31/2013	9:00AM	PST	Management - Staff Assistant		Inhouse1	0.000	<a href="#">Evaluate Applicant</a>
1006	Francine Felkner	01/25/2013	10:00AM	PST	Analyst-Business		Inhouse2	0.000	<a href="#">Evaluate Applicant</a>

### Filtering Fields

<i>Field or Control</i>	<i>Description</i>
<b>Show Interviews Between</b>	To filter the list of evaluations based on the interview date, enter a date range in these fields.
<b>Refresh</b>	Click up update the list of evaluations based on the specified date range.

### Interview Evaluations

This grid lists all of the interviews where you are an interviewer. It also includes any evaluations that you created without the context of a specific interview.

<b>Field or Control</b>	<b>Description</b>
<b>Action</b>	<p>Displays one of the following links:</p> <ul style="list-style-type: none"> <li>• <i>Evaluate Applicant</i> appears when the evaluation has not yet been started. Click to access the Interview Evaluation page and begin the evaluation.</li> <li>• <i>Complete Evaluation</i> appears when the evaluation has been saved, but not yet submitted. Click to access the Interview Evaluation page and continue to work on the evaluation.</li> <li>• <i>View Evaluation</i> appears when the evaluation has been submitted. Click to access the read-only version of the Interview Evaluation page.</li> </ul> <hr/> <p><b>Note:</b> This page, which is used for managing a user’s personal list of evaluations, does not provide administrators with a link for editing completed evaluations.</p> <hr/>

## Interview Evaluation Page

Use the Interview Evaluation page (HRS\_INT\_EVAL) to create, update, or review interview evaluations.

Navigation:

Select **Recruiting Actions** > **Create Interview Evaluation** from the Other Actions menu on any of these pages:

- Manage Job Opening (also available as a group action)
- Manage Applicant
- Manage Application
- Search Applications

You can also access evaluations from these pages that include a grid showing evaluations:

- Interview Evaluations (list) page
- Manage Interview page
- Manage Application page: Interview tab
- Manage Applicant page: Applicant Activity tab: Interview Schedule/Evaluations section

This example illustrates the Interview Evaluation page.

### Toolbar Buttons: General

<b>Field or Control</b>	<b>Description</b>
<b>Previous and Next</b>	If you accessed the page using a group action on the Manage Job Opening page, use these buttons to scroll to each applicant who is being evaluated.
<b>Return</b>	Click to cancel any unsaved changes and return to the previous page.

### Toolbar Buttons for Evaluators

<b>Field or Control</b>	<b>Description</b>
<b>Submit</b>	Click this button to submit completed evaluations and return to the previous page. If you accessed the page using a group action, all evaluations included in the selection must be complete before you can submit. The system displays error messages if there is any missing data.
<b>Save as Draft</b>	Click this button to save your work without submitting any evaluations.

## Toolbar Buttons for Administrator Edits

These buttons are available when an administrator accesses a submitted evaluation by clicking the Edit Evaluation link. The option for administrators to edit evaluations is available only if activated on the [Recruiting Installation – Applicants Page](#).

<b>Field or Control</b>	<b>Description</b>
<b>Edit</b>	<p>Click the <b>Edit</b> button to make a submitted evaluation editable. When the page changes to editable mode:</p> <ul style="list-style-type: none"> <li>• The <b>Send Back</b> and <b>Delete</b> buttons disappear.</li> <li>• The <b>Save</b> button appears.</li> <li>• The <b>Edited By</b>, <b>Date Edited</b>, and <b>Edit Evaluation Comments</b> fields appear in an <b>Edit Evaluation</b> group box.</li> <li>• The administrator can update the original evaluator's ratings, recommendations, and comments.</li> </ul>
<b>Save</b>	<p>This button appears only after the administrator clicks the <b>Edit</b> button. Click this button to save changes, send the modified evaluation back to the original evaluator, and return to the previous page. Sending an evaluation back reverses the evaluation submission; it is as if the original evaluator saved it without submitting it. Therefore, after saving, the administrator is not able to re-access the evaluation until the original evaluator resubmits it.</p>
<b>Send Back</b>	<p>Click this button to send the evaluation back to the original evaluator. Sending an evaluation back reverses the evaluation submission; it is as if the original evaluator saved it without submitting it.</p>
<b>Delete</b>	<p>Click this button to delete the evaluation entirely. All data is cleared, and the system displays the page from which you accessed the evaluation.</p> <p>The Interview Evaluations grid no longer displays data for the deleted evaluation. Instead, the Action field displays <i>Evaluate Applicant</i>, the text that appears when no evaluation data exists.</p>



## Header Information

<i>Field or Control</i>	<i>Description</i>
<b>Name, and Applicant ID</b>	Displays identifying information about the applicant.
<b>Status</b>	Displays the applicant's overall status (not the applicant's disposition).
<b>Job Posting Title and Job Opening ID</b>	Displays identifying information about the job opening. All evaluations require the context of a job opening (or an application with no job opening). You cannot enter a general evaluation of the applicant across all applications.
<b>Job Opening Status</b>	Displays the current status of the job opening.

## Evaluation

<i>Field or Control</i>	<i>Description</i>
<b>Interview Date</b>	Displays the date of the interview. If you create a new evaluation without the context of a specific interview, the default is the date of the applicant's most recent interview. You can override this date if necessary.  If there is no interview scheduled for the applicant, you can still create an evaluation. The default interview date is the current date.
<b>Interview Type</b>	Displays the interview type. When you create a new evaluation for a specific interview, the default interview type comes from the interview schedule, but you can override this value. It is not necessary to keep the interview type the same in the interview evaluation and the interview schedule.

## Recommendation

<i>Field or Control</i>	<i>Description</i>
<b>Overall Rating</b>	Enter an overall rating. Select from the values that were defined on the <a href="#">Interview Evaluation Ratings Page</a> .

<b>Field or Control</b>	<b>Description</b>
<b>Recommendation</b>	Enter an overall recommendation. Select from the statuses are defined for the Interview status area on the <a href="#">Recruiting Status and Reason Page</a> .
Reason	If the interview evaluation template is configure to require a reason for the recommendation you select, the Reason field appears. The available values are the reasons that are associated with the status that you selected as the recommendation.
<b>General Comments</b>	Enter text comments to support the overall recommendation.

### Interview Ratings

<b>Field or Control</b>	<b>Description</b>
<b>Category</b>	The grid lists the rating categories that are associated with the interview template for the job opening.
<b>Interview Rating</b>	Select a rating for the given category. Values come from the interview evaluation template for the job opening.
Score	The system displays the score that is associated with the rating you select. Ratings are associated with scores in the interview evaluation template for the job opening.
<b>Comments</b>	Enter an evaluation comment for the specified category.

### Edit Evaluation

This section is visible if an administrator accesses the page in administrative update mode (by clicking the **Edit Evaluation** link in the Interview Evaluations grid on various pages).

If the administrator saves changes, these fields remain visible to anyone else who views the evaluation. These fields provide the only audit trail for modified evaluations.

This example illustrates the Edit Evaluation fields on the Interview Evaluation page.

**Edit Evaluation**

<b>Edited By</b>	<b>Date Edited</b>
<b>Comments</b>	<input style="width: 95%; height: 20px;" type="text"/>

<b>Field or Control</b>	<b>Description</b>
<b>Edited By</b> and Date Edited	These fields display system-generated information about who edited the evaluation and when it was edited.
<b>Comments</b>	An administrator who edits an evaluation uses this field to enter comments related to the edit.

### Interview Evaluation Page (Read Only)

Use the read-only Interview Evaluation page (HRS\_VIEW\_INT\_EVAL) to review a submitted evaluation.

This is the first of two examples illustrating the read-only Interview Evaluation page that appears when a user accesses a submitted evaluation.

**Interview Details**

**Interview Evaluation**

<b>Applicant Name</b> Ramilio Estavias	<b>ID</b> 500007
<b>Job Opening ID</b> 503708	<b>Job</b> Bring Your Arbitration Experience to Labor Relations
<b>Submitted By</b> HCQAN-R	<b>Date Submitted</b> 02/05/13 5:13PM

**Interview Evaluation Details**

<b>Interview Date</b> 09/30/2009	
<b>Interviewer Name</b> Jake Oglevy	
<b>Evaluation Date</b> 02/05/2013	
<b>Interview Type</b> Inhouse1	

**Rate Applicant**

Category	Interview Rating	Score	Comments
Communication Skills	Excellent	2	
Education/Training	Excellent	2	
Work Experience	Excellent	2	
Technical Skills	Excellent	2	

This is the second of two examples illustrating the read-only Interview Evaluation page that appears when a user accesses a submitted evaluation.

<b>Recommendation</b>	
Overall Rating	Excellent
Recommendation	020 Make Offer
	Reason
<b>General Comments</b>	
<div style="border: 1px solid black; height: 60px; width: 100%;"></div>	
Edited By	KU0007
Date Edited	02/05/13 5:12PM
<b>Edit Evaluation Comments</b>	
<div style="border: 1px solid black; padding: 5px;">Please add comments to your evaluation.</div>	
<a href="#">Return to Previous Page</a>	

This page displays information about the applicant, the job opening, the interview, and the evaluator. It then shows the ratings for individual evaluation categories and the overall recommendation.

Comments for specific evaluation categories are not shown on this page. Instead, you can click the Comments icon for a category to see the comments.

## Evaluation Rating Comments Page

Use the Evaluation Rating Comments page (HRS\_INT\_EVAL\_SEC) to view an evaluator’s comments for a specific evaluation category.

Navigation:

Click the **Comments** icon on the view-only Interview Evaluation page.

This example illustrates the Evaluation Rating Comments page.

### Evaluation Rating Comments

Applicant Name Ganguly Sarbani

Category Work Experience

Comment Although he does not have as many years of experience as some other applicants, I think this is not an issue in light of his extremely strong skills.

OK
Cancel

---

## Finalizing Interviews and Sending Evaluation Reminders

This topic provides an overview of interview evaluation reminders and discuss how to send interview evaluation reminders.

### Page Used to Finalize Interviews and Send Evaluation Reminders

<i>Page Name</i>	<i>Definition Name</i>	<i>Usage</i>
<u>Interview Evaluation and Finalization Page</u>	HRS_RUN_INT_REM	Run a process to mark interviews complete and to optionally send interview evaluation reminders.

### Understanding Interview Finalization and Evaluation Reminders

The Interview Evaluation Reminder (HRS\_INT\_EVAL) Application Engine process performs these two tasks:

- Applies the interview status *Completed* when all evaluations for an interview in the past have been completed.

- (Optional) Sends a notification (HRS\_INTVW\_EVAL\_RMNDR) to interviewers who have not yet submitted evaluations for interviews that are in the past.

Reminders are sent if the interview is in the past. Reminders are not sent if the interview is canceled, nor are reminders sent to interviewers who declined the interview.

The run control page for the process includes a check box that you use to indicate whether to include the optional task of sending reminders.

To prevent the system from processing every interview in the system, you must specify a date range for the interviews to be processed. You can enter actual dates, or you can specify the number of days to look back from the current date.

---

**Note:** Entering a final recommendation for the interview is a separate task. Enter the final recommendation for an interview on the [Manage Interviews Page](#) or on the [Manage Application Page: Interview Tab](#).

---

## Interview Evaluation and Finalization Page

Use the Interview Evaluation and Finalization page (HRS\_RUN\_INT\_REM) to run a process to mark interviews complete and to optionally send interview evaluation reminders.

Navigation:

**Recruiting > Administration > Interview Evaluation Reminder**

This example illustrates the Interview Evaluation and Finalization page.

**Interview Evaluation and Finalization**

Run Control ID PS Report Manager Process Monitor Run

Interviews Scheduled From  To

-- OR --

Between  and  days prior to today

Send Evaluation Reminders

<i>Field or Control</i>	<i>Description</i>
<b>Interviews Scheduled From and To</b>	Enter specific dates to be used when processing interviews. The system processes interviews that are scheduled on or between the dates you enter.

<b>Field or Control</b>	<b>Description</b>
<b>Between</b> and <b>And</b> <number of> days prior to today	<p>Enter two numbers that define how many days to look back when processing interviews. For example, enter 1 and 7 to process interviews that are scheduled for one to seven days before the day that the process runs.</p> <p>Use these fields only if you do not enter specific dates in the <b>Interviews Scheduled From</b> and <b>To</b> fields.</p>
<b>Send Evaluation Reminders</b>	<p>Leave this check box selected if you want the Interview Evaluation Reminder process to send reminder notifications to interviewers who have not completed evaluations for the interviews that the system processes. Reminders are sent if the interview is in the past. Reminders are not sent if the interview is canceled, nor are reminders sent to interviewers who declined the interview.</p> <p>Deselect this check box to skip reminder processing.</p> <hr/> <p><b>Note:</b> The Interview Evaluation Reminder process always applies the <i>Completed</i> status to completed interviews that it processes. There is no option to deactivate this part of the process.</p> <hr/>

## Reviewing Interview Schedules

This topic discusses how to review personal and team interview schedules.

### Pages Used to Review Interview Schedules

<b>Page Name</b>	<b>Definition Name</b>	<b>Usage</b>
<u>Interview Summary Page</u>	HRS_VW_INT_PG	Review all interviews that have been scheduled for a single job opening, including draft interviews that have not yet been submitted.
<u>Interview Calendar Page</u>	HRS_INT_CLNDR	See a weekly schedule of your own interviews.
<u>Recruiter Comments Page</u>	HRS_INT_COMM_SEC	View user-specific interview notes.
<u>Interview Team Schedule Page</u>	HRS_SEL_TEAM_SCHED	View a list of job openings or applicants where you are part of the interview team, and access detailed interview schedule information as needed.

## Interview Summary Page

Use the Interview Summary page (HRS\_VW\_INT\_PG) to review all interviews that have been scheduled for a single job opening, including draft interviews that have not yet been submitted.

Navigation:

Click the Interviews toolbar button on the Manage Job Opening Page. This button is visible only if interviews have been scheduled for the job opening.

This example illustrates the Interview Summary page.

The screenshot shows the 'Interview Summary' page. At the top, there are navigation links for 'Return' and 'Print Interviews'. Below this, job opening details are listed: Job Opening ID 30002, Job Opening Status 010 Open, Job Posting Title Assistant-Administrative, and Business Unit GBIBU (Global Business Institute BU). The applicant's name is Amalia Acevedo (1) with a disposition of 060 Interview. A section for 'Interview 1 - 09/01/2004 10:00 AM To 11:00 AM PST' contains a table of interviewers:

Name	Status	Interview Type	Date	Start Time	End Time	Time Zone
Charles Baran	Unconfirmed	Inhouse2	09/01/2004	10:00AM	11:00AM	PST
Jean Parsons	Unconfirmed	Inhouse2	09/01/2004	10:00AM	11:00AM	PST
Daisy Lopez	Unconfirmed	Inhouse2	09/01/2004	10:00AM	11:00AM	PST

Below the table, there are expandable sections for other applicants: Bryan Baas (1), Carolina Ceballos (1), and Ismael St James (1). At the bottom, there are 'Expand All' and 'Collapse All' links.

### Toolbar

<b>Field or Control</b>	<b>Description</b>
<b>Return</b>	Click to return to the Manage Job Opening page.
<b>Print Interviews</b>	Click to create the Interview Summary report (HRS_BIP_INTS), which includes the same information that appears on the Interview Summary page.  The report opens in a new browser window, where you can print it using your browser's print command.

### Interview Details

The page displays a collapsible **Interview Details** section for every applicant with an interview schedule. The section header displays the applicant's name and the number of scheduled interviews.

<b>Field or Control</b>	<b>Description</b>
<b>Disposition</b>	Displays the applicant's current disposition.



<b><i>Field or Control</i></b>	<b><i>Description</i></b>
<b>Interview &lt;sequence number&gt;</b>	Within the collapsible section for each applicant, each interview appears as a group box with a header that provides the interview sequence number and the interview date and time. The date and time are shown in the time zone that was entered on the Schedule Interview page.

## Interviewers

<b><i>Field or Control</i></b>	<b><i>Description</i></b>
<b>Name</b>	The <b>Interviewers</b> grid lists the names of all interviewers for a single interview.
<b>Status</b>	Displays the overall interview status (not the status of the individual interviewer). The value is the same for every interviewer.
<b>Interview Type</b>	Displays the interview type that was selected on the Schedule Interview page. The value is the same in every row of the grid.
<b>Date, Start Time, End Time, and Time Zone</b>	These fields show the interview time in each interviewer's own time zone.

## Interview Calendar Page

Use the Interview Calendar page (HRS\_INT\_CLNDR) to see a weekly schedule of your interviews.

Navigation:

- **Recruiting > Interview Calendar**
- **Self Service > Recruiting > Interview Calendar**

This example illustrates the Interview Calendar page.

Interview Calendar for Betty Locherty						
<a href="#">Recruiting Home</a>						
<input type="text" value="01/12/2014"/>				As of Monday, January 13, 2014 03:41 PM PST		
Date	Time	Applicant	Job Posting Title	Comments	Status	Interview Location
Sunday January 12, 2014	There are no interviews scheduled on this day.					
Monday January 13, 2014	09:00 AM - 09:45 AM	Francine Felkner	Analyst-Business - 30005		Unconfirmed	HQ750
Tuesday January 14, 2014	09:00 AM - 09:30 AM	Carry Jane	Junior Assistant 11636888 - 300237		Confirmed	
	09:30 AM - 10:00 AM	Esther Evans	Analyst-Business - 30005		Unconfirmed	HQ750
Wednesday January 15, 2014	There are no interviews scheduled on this day.					
Thursday January 16, 2014	03:30 PM - 04:00 PM	Geraldine Gates	Analyst-Business - 30005		Unconfirmed	HQ750
Friday January 17, 2014	03:30 PM - 04:00 PM	Salvador Sanchez	Analyst-Business - 30005		Unconfirmed	HQ750
Saturday January 18, 2014	There are no interviews scheduled on this day.					

### Date Controls

The interview calendar always displays a weekly schedule. The weekends are shaded gray, and the current date is shaded blue. The first day of the week is determined by the user’s personalizations. User set this personalization by selecting My Personalizations under the main menu and then clicking the **Personalize Regional Settings** link.

Field or Control	Description
<Display Week Of>	When you enter a date, the system displays the week containing that date. The system also updates the date field to display the first day of the selected week.
	Click the <b>Previous Week</b> and <b>Next Week</b> icons to scroll through weeks without entering actual dates.
As of <date>	Informational text shows the date and time that the data on the page was last refreshed. This text also indicates the time zone in which all dates and times are shown.
	Click the <b>Refresh</b> icon to refresh the data on the page.

### Weekly Calendar

The calendar shows all submitted (non-draft) interviews for the week. The calendar also includes links to related pages. Links are disabled when users do not have security access to the target page.

<b>Field or Control</b>	<b>Description</b>
<b>Date</b>	Displays the date for each day of the week.
<b>Time</b>	<p>On days where interviews are scheduled, this column displays the start and end time of the interview. These times are shown in the same time zone shown in the informational text at the top of the page.</p> <p>Click the time to access the <a href="#">Interview Schedule Page</a>. When accessed this way, the Interview Schedule page is editable only if the user has row-level access to the job opening as well as security access to the Manage Job Opening or Manage Applicant component.</p> <p>On days where no interviews are scheduled, the message <i>There are no interviews scheduled on this day</i> appears, and the remaining columns in the calendar are blank.</p>
<b>Applicant</b>	Displays the name of the applicant to be interviewed. Click the link to access the <a href="#">Manage Applicant Page</a> . The applicant name appears as plain text rather than a link if the user does not have security access to the Manage Applicant page.
<b>Job Posting Title</b>	Displays the title of the job for which the applicant is interviewing. Click to access the <a href="#">Manage Job Opening Page</a> . The job posting titles appears as plain text rather than a link if the user does not have security access to the Manage Job Opening page and also security to access the specific job opening.
	The <b>Comments</b> icon appears if interviewer-specific comments were added on the Interview Schedule page. Click the icon to view the comments on the <a href="#">Recruiter Comments Page</a> .
<b>Status</b>	Displays the interview status from the Interview Schedule page.
<b>Interview Location</b>	Displays the interview location.

## Recruiter Comments Page

Use the Recruiter Comments page (HRS\_INT\_COMM\_SEC) to view comments entered on the Interview Schedule page.

Navigation:

Click the Comments icon on the Interview Calendar page

This example illustrates the Recruiter Comments page.

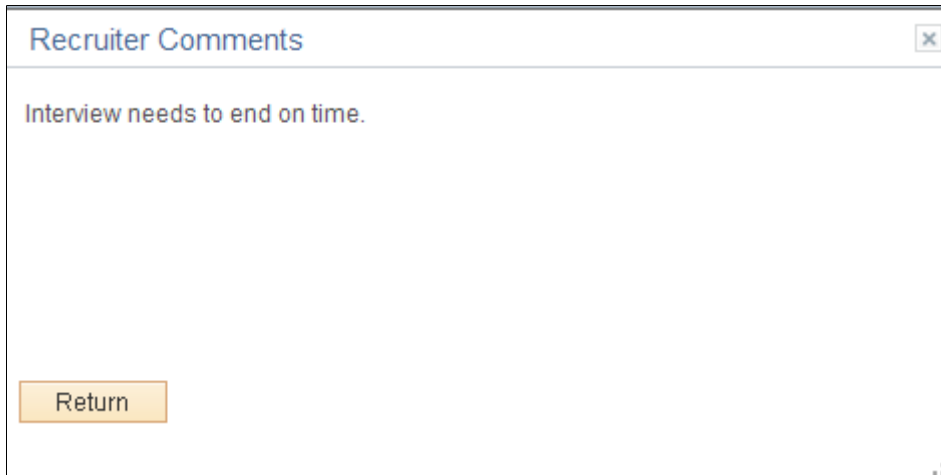

## Interview Team Schedule Page

Use the Interview Team Schedule page (HRS\_SEL\_TEAM\_SCHED) to view a list of job openings or applicants where you are part of the interview team, and to access detailed interview schedule information as needed.

Navigation:

**Self Service > Recruiting > Interview Team Schedule**

This example illustrates the Schedules With Job Opening tab on the Interview Team Schedule page.

### Interview Team Schedule

**Schedules with Job Opening**    Schedules without Job Opening

---

Select View Schedule to see a list of applicants scheduled to be interviewed for the selected Job Opening.

▼ **Filters** ?

- Job Opening in Non-Open Status
- Applicant is no longer in Interview Status

**Team Schedule**

1-10 of 14
> > | [View All](#)

Job ID	Job Opening	Department	View Schedule
505012	Assistant Manager	Finance and Administration	<a href="#">View Schedule</a>
505003	System Administrator	Nursing	<a href="#">View Schedule</a>
504072	Procurement Manager	Revenue Management	<a href="#">View Schedule</a>
504030	Sales Product Consultant	Western Sales Region	<a href="#">View Schedule</a>
500353	Sr Teaching Assistant	Educ & Govt Operations	<a href="#">View Schedule</a>
305123	Employee Relations Specialist	All Depts for City of Nelson	<a href="#">View Schedule</a>
305106	Office Assistant(Ponciano as Primary HM)	Business Services	<a href="#">View Schedule</a>
300250	POI Access	Human Resources	<a href="#">View Schedule</a>
300223	Office Assistant	Business Services	<a href="#">View Schedule</a>
300064	Store Manager Q	Business Services	<a href="#">View Schedule</a>

This example illustrates the Schedules without Job Opening tab on the Interview Team Schedule page.

### Interview Team Schedule

Schedules with Job Opening
**Schedules without Job Opening**

Select View Schedule to see a list of applicants scheduled to be interviewed.

▼ **Filter** ?

Applicant is no longer in Interview Status

**Team Schedule**

	<< < 1-1 of 1 > >>   <a href="#">View All</a>		
Applicant ID	Applicant Name	Interview Date	View Schedule
500022	Antoinette Gisella	22/04/2024	<a href="#">View Schedule</a>

<b>Field or Control</b>	<b>Description</b>
<b>Schedule With Job Opening</b>	On this tab, the <b>Team Schedule</b> grid lists the jobs where the user is scheduled to interview applicants. Each row in the grid displays the job opening ID, posting title, and department along with a link for accessing the Interview Schedule page in view-only mode.
<b>Schedule Without Job Openings</b>	On this tab, the <b>Team Schedule</b> grid lists the applications without job openings where the user is scheduled to interview the applicant.  Each row in the grid displays the applicant ID, applicant name, and interview date along with a link for accessing the Interview Schedule page in view-only mode.
<b>Filters</b>	Select option to refine your search for specific job openings and applicants. Options include <i>Job Opening in Non-Open Status</i> and <i>Applicant is no longer in Interview Status</i> .  Select <i>Job Opening in Non-Open Status</i> to view job openings in Closed, Hold or Cancelled status.  Select <i>Applicant is no longer in Interview Status</i> to view job openings with one or more applicants not in Interview status.

## Chapter 25

# Making Job Offers

---

## Creating Job Offers

This topic provides an overview of job offers and discusses how to create job offers.

### Pages Used to Prepare Job Offers

<i>Page Name</i>	<i>Definition Name</i>	<i>Usage</i>
<a href="#">Prepare Job Offer Page</a>	HRS_APP_RCMNT	Create and manage a job offer.
<a href="#">Organizational Level Documents Page</a>	HRS_OFF_SELATC_SEC	Select items from your organization's library of existing attachments, and attach them to the job offer.
<a href="#">Document Definitions Page</a>	HRS_OFF_SELDOC_SEC	Add document definition attachments to an offer.
<a href="#">Post Online Job Offer Page</a>	HRS_OFFER_SEND_SEC	Post a job offer to Candidate Gateway.

## Understanding Job Offers

This overview describes job offers.

### Offer Creation

Create and manage job offers on the Prepare Job Offer page. To access this page, use the Prepare Job Offer action. This action is available from multiple locations:

- Manage Job Opening page: Applicant tab
- Manage Applicant page: Applicant Activity page: Current Status section
- Search Applications page
- Manage Application page

You can also access an existing offer by clicking the **Edit Offer** link on the Manage Application page: Offer tab

## Position and Job Code Information

The Prepare Job Offer page displays job information that comes from the job opening, including the business unit, position number, and job code. If the job opening is associated with multiple positions or job codes, you can select the one to which the offer applies.

There are two situations where position and job code data are not available to be brought into the job offer:

- If you initiate the offer process for an applicant who is not linked to a job opening.
- If you initiate the offer process for an applicant who is linked to a continuous job opening that doesn't have position or job code data.

In these situations, you must enter the necessary data on the Prepare Job Offer page (or, for continuous job openings, on either the Prepare Job Offer or the Prepare for Hire page). The requirements for position and job code data depend on your position management settings:

- *Full position management:* All offers must include a position number.

When you enter a position number in the job offer, the system brings in the associated job code.

- *Partial position management:*
  - Offers that are not associated with any job opening must include a job code; a position number is optional.
  - Offers that are related to continuous job openings can be submitted without a position or job code, but you will not be able to prepare the applicant for hire without at least a job code.

## Online Job Offers

On the [Recruiting Installation – Applicants Page](#), you can configure the system to support online job offers through PeopleSoft Candidate Gateway. When this functionality is active, you can post offers to Candidate Gateway, and applicants can review the posted offers (along with offer attachments) and then accept or reject the offer online.

When you post a job offer, the system sends the applicant an email notification containing a link to Candidate Gateway. If the applicant's contact information doesn't include an email address, you cannot post the job offer online.

Posting an offer also creates an applicant contact note that you can see on the Manage Applicant page.

When online job offer functionality is active, the Prepare Job Offer page displays several additional page elements that support the online job offer process, including:

- An offer expiration date, after which the online offer becomes read-only.

The default date is based on the setting on the Recruiting Installation - Applicants page that specifies how many days online job offers remain active. You can override the default value.

- Relevant applicant information, including applicant type, whether the applicant is a registered user of Candidate Gateway, and the applicant's preferred contact method.



- An Attachments section for the files, URLs, and notes that you want to make available to the applicant along with the offer.

Any offer letter that you generate is always added to the attachments grid. You can also manually add additional attachments, including local files that you attach and generic documents from your organization's attachment library.

- Links for posting and unposting offers to Candidate Gateway.

When you modify a job offer, saving the changes does not update the online offer in Candidate Gateway. Instead, you must unpost the offer and then repost it.

## Offer Letters

Talent Acquisition Manager uses Oracle Business Intelligence Publisher (BI Publisher) to generate recruitment letters, including offer letters.

When you enter job offer information, you choose a template to use for the offer letter. After the offer is submitted (and, if necessary, approved), you can then generate the letter manually on the Prepare Job Offer page. If you do not generate a letter manually, then the system adds the letter to the queue for the HRS Letter Generation process (HRSLETTR). This process generates all queued letters in batch.

The buttons that you use to generate a letter from the job offer are not available when the offer is in an editable state, even if the offer has been submitted and approved. If you edit an offer, you must resubmit it before generating the letter. Submitting makes the offer fields read-only, thus activating the buttons for generating the letter. This behavior ensures that any changes to the offer are saved before the letter is generated, so the letter always brings in the most current offer amounts.

## Components of Pay

The offer must include compensation information. This takes the form of one or more components of pay such as base salary, bonuses, car and meal allowances, and so forth. When you enter components of pay, you select from components that you set up in the Offer Component Type and Offer Component pages.

See [Setting Up Job Offer Components](#).

## Prepare Job Offer Page

Use the Prepare Job Offer page (HRS\_APP\_RCMNT) to create and manage a job offer.

Navigation:

Select **Other Actions** > **Recruiting Actions** > **Prepare Job Offer** on any of the following pages:

- Manage Job Opening page: Applicant tab
- Manage Applicant page: Applicant Activity page: Current Status section
- Search Applications
- Manage Application

When an offer already exists, you can also click the **Edit Offer** link on the Manage Application page: Interview tab.

This is the first of two examples illustrating the Prepare Job Offer page. In this example, the offer has been through the approval process, so the offer information is on an Offer Details tab and the approval information is on an Approvals tab. If approvals are not active, the page does not have tabs.

This is the second of two examples illustrating the Prepare Job Offer page.

### Toolbar

<b>Field or Control</b>	<b>Description</b>
<b>Return</b>	Click to return to the page from which you accessed the job offer. If you have unsaved data, the system asks if you want to save your data first.
<b>Recruiting Home</b>	Click to access the <a href="#">Recruiting Home Page</a> . If you have unsaved data, the system asks if you want to save your data first.

### Header

The header area of the page displays identifying information about the applicant, the job opening, the job code, and if relevant, the position number.

Some fields may not have values if this offer is for an application that does not include a job opening or if the job opening is a continuous job opening without a job code.

## Offer Details

Note that the Offer Details section is a scroll area for accessing all of the offers that exist for the current applicant and job opening. Typically, you do not create additional offers unless the original offer has been rejected or withdrawn. This ensures that there is not more than one offer extended at a time.

<b>Field or Control</b>	<b>Description</b>
<b>Job Opening</b>	Displays the job opening ID and posting title. If the offer was created without the context of a job opening, the field is editable so that you can supply a job opening ID.
<b>Position Number</b>	<p>This field appears only if the system is configured for full or partial position management. Under full position management, a position number is required. Under partial position management, it is optional.</p> <p>Initially, this field displays the position number, if any, that is associated with the job opening. If the job opening is associated with multiple positions, you can select any of the associated positions.</p> <p>If the offer is not associated with a job opening, or if it is associated with a continuous job opening that doesn't have position data, you can manually enter a value (and must do so under full position management).</p>
<b>Job Code</b>	<p>Initially, this field displays the job code that is associated with the job opening. If the job opening is associated with multiple jobs, you can select any one of the associated job codes.</p> <p>If the offer includes a position number (required under full position management), the system enters the associated job code.</p> <p>If the offer is not associated with a job opening, then you must manually enter either a job code or position number.</p> <p>If the job opening is a continuous job opening without job code data, then the job code is optional. However, a job code will be required before you can prepare the applicant for hire.</p>
<b>Hiring Manager</b>	The default value is the primary hiring manager for the job opening. You can override this value if necessary.

<b><i>Field or Control</i></b>	<b><i>Description</i></b>
<b>Recruiter</b>	The default value is the primary recruiter for the job opening. You can override this value if necessary.

<b>Field or Control</b>	<b>Description</b>
<b>Status</b>	<p>Although you can configure offer statuses on the <a href="#">Recruiting Status and Reason Page</a>, Oracle delivers a complete set of statuses and recommends that you use the delivered status codes.</p> <p>Generally you can let the system set the value based on the actions you perform. However, it is possible to manually select an offer status except for these situations:</p> <ul style="list-style-type: none"> <li>• During approval processing, when the approval process sets the status.</li> <li>• When a posted offer is in the <i>Accept</i> status (or whichever status is configured as the complete status for offers).</li> </ul> <p>The delivered statuses are:</p> <ul style="list-style-type: none"> <li>• <i>Draft</i>: the offer has been saved but not yet submitted.</li> <li>• <i>Pending Approval</i>: the offer was submitted for approval and is still in the approval process.</li> <li>• <i>Denied</i>: offer approval was denied.</li> <li>• <i>Extend</i>: the offer is open and awaiting the applicant's reply. When the offer goes into this status, the delivered status change effects also change the applicant's disposition to <i>070 Offer</i>.</li> <li>• <i>Accept</i>: the applicant accepted the offer. When the offer goes into this status, the delivered status change effects also change the applicant's disposition to <i>071 Offer Accepted</i>.</li> <li>• <i>Acceptance Withdrawn</i>: When the offer goes into this status, the delivered status change effects also change the applicant's disposition back to <i>070 Offer</i>.</li> <li>• <i>Hold</i>: the offer is on hold.</li> <li>• <i>Offer Rejected</i>: the applicant rejected the offer. When the offer goes into this status, the delivered status change effects also change the applicant's disposition to <i>110 Reject</i>.</li> <li>• <i>Offer Withdrawn</i>: the offer has been withdrawn. When the offer goes into this status, the delivered status change effects also change the application disposition to <i>120 Withdrawn</i>.</li> </ul>

<b>Field or Control</b>	<b>Description</b>
<b>Reason</b>	If your organization has set up reasons for a particular status, you can select a reason for putting the offer in a status. For example, reasons for the <i>Offer Rejected</i> status might include <i>Base Salary</i> , <i>Benefits</i> , or <i>Personal</i> .
<b>Created By</b>	Displays the name of the person who created the job offer.
<b>Business Unit</b>	Displays the business unit that is associated with the job opening. If the offer was created without the context of a job opening, the field is editable so that you can supply a business unit.
<b>Offer Date</b>	Enter the date the offer is effective. The default is the current date.
<b>Start Date</b>	Enter the date that the applicant is to report for work. This date cannot be before the offer date.
<b>Works Council ID</b>	<p>This field appears if job offers require works council approval. This occurs if the <b>Optional Works Council</b> approval option is selected on the <a href="#">Recruiting Installation - General Page</a> and if the job opening template includes the Works Council section.</p> <p>The default value is the works council ID associated with the job opening.</p>

### Offer Details: Additional Fields for Online Job Offers

**Note:** These fields appear only if the system is configured to allow online job offers for this job opening's regulatory region.

<b>Field or Control</b>	<b>Description</b>
<b>Offer Expiration Date</b>	<p>The default value is date based on the system-wide setting for the default number of days that an online job offer remains active. This setting is configured on the <a href="#">Recruiting Installation – Applicants Page</a>.</p> <p>If you change the expiration date for a job that is already posted to Candidate Gateway, you do not need to unpost and repost the job opening to make the change effective.</p>

<b>Field or Control</b>	<b>Description</b>
<b>Applicant Type</b>	<p>Displays <i>Employee</i>, <i>External Applicant</i>, or <i>Non-Employee</i>. Non-employees are applicants who, although not current employees, already have data in the PeopleSoft HCM system.</p> <p>External applicants and non-employees can access Candidate Gateway only if they are registered Candidate Gateway users. Refer to the <b>Registered Online</b> field to see if these types of applicants are registered users.</p> <p>Employees do not register for Candidate Gateway. Instead, they need to have a PeopleSoft user ID that provides access to Candidate Gateway. Your organization's business practices determine whether employees have the necessary PeopleSoft user IDs.</p>
<b>Registered Online</b>	<p>This field is visible only if the applicant type is <i>External Applicant</i> or <i>Non-Employee</i>.</p> <p>This field displays <i>Yes</i> if the applicant is a registered user of Candidate Gateway. This indicates that the applicant is able to view online job offers.</p> <p>A value of <i>No</i> prevents you from posting the offer to Candidate Gateway.</p>
<b>Preferred Contact</b>	<p>Displays the applicant's preferred contact method. Refer to this field when notifying applicants of online job offers.</p>
<b>Notify Applicant</b>	<p>This check box must be selected before you post a job offer online. Selecting the check box indicates that the system will send an email notification when the job offer is posted.</p> <p>If the preferred contact method is <i>Email</i>, the <b>Notify</b> check box is selected by default. If the preferred contact method is anything else, the check box is initially not selected, and you must manually select this check box before posting an online job offer. If you select this check box, but the applicant record does not include an email address, the system displays an error message if you attempt to post the offer.</p> <hr/> <p><b>Note:</b> The setting for the Notify check box does not get saved. Each time you access this page, the check box setting is based on the applicant's preferred contact method.</p> <hr/>

## Actions

<b>Field or Control</b>	<b>Description</b>
<b>Save as Draft</b>	Saves the job offer and puts it in the status configured as the draft status for offers. You must have at least one row in the Job Offer Components grid before you can save the offer.
<b>Submit Offer</b>	<p>This link is visible if offers do not require approval. Click to save the offer and set the status to the default status for the offer area. As delivered, the default status is <i>Extend</i>.</p> <p>After you submit an offer, it becomes read-only, and this link is no longer active. If you need to make additional changes, click the <b>Edit Offer</b> link.</p> <p>If the offer that you are submitting brings the total number of hires and of applicants with offers over the number of target openings for a standard requisition, the system displays a warning. The system only counts offers and hires that were created through prepare job offer and prepare for hire processes; it does not take into consideration any manual disposition changes.</p> <p>You can submit the offer anyway, but doing so can cause problems. The best practice is to promptly update the statuses of rejected and withdrawn offers to avoid having multiple offers active in the system at once.</p>
<b>Submit for Approval</b>	This link replaces the <b>Submit Offer</b> link if offers require approval. Click to submit the offer, start the approval process, and set the status to the value configured for pending approvals. As delivered, submitting an offer for approval sets the status to <i>Pending Approval</i>
<b>Post</b>	<p>Click this link to access the Post Online Job Offer page, where you complete the process of posting the job offer to Candidate Gateway. If the applicant does not have an email address, you will not be able to post the offer.</p> <p>This link is visible only if the system is configured to allow online job offers for this job opening's regulatory region. It is active when the offer has been submitted (but is not currently posted) and the applicant is either an employee or a registered external user of Candidate Gateway.</p> <p>If you click the <b>Edit Offer</b> link, the Post link becomes unavailable until the offer is resubmitted.</p>



<b>Field or Control</b>	<b>Description</b>
<b>Unpost</b>	<p>Click this link to remove a posted offer from Candidate Gateway. To post offer revisions, it is necessary to unpost and then re-post the offer.</p> <p>This link is visible only if the system is configured to allow online job offers for this job opening's regulatory region. It is active only for posted offers. If you click the <b>Edit Offer</b> link, the Unpost link becomes unavailable until the offer is resubmitted.</p>
<b>Add Revised Offer</b>	<p>This link is available if the offer has a status of <i>Rejected</i>. Click to add a new job offer. Clicking this link creates a new row in the Offer Details scroll area.</p>
<b>Delete Offer</b>	<p>This link is active only for recruiting administrators. An administrator clicks this link to delete the offer. A new, blank offer replaces the deleted offer on the Prepare Job Offer page.</p> <p>If the deleted job offer was posted to Candidate Gateway, deleting the offer also removes the posted offer.</p> <p>Deleting an offer does not remove any associated contact notes, nor does it update the applicant's disposition.</p>
<b>Edit Offer</b>	<p>When you save or submit an offer, or when you initially access an existing offer, the offer is not editable. Click the <b>Edit Offer</b> link to make the fields on the page editable.</p> <p>When you modify a posted job offer, changes other than attachment-related changes are not reflected in Candidate Gateway until you unpost the offer and then re-post it.</p> <p>However, if you change the attachments in a posted offer, the changes are immediately visible in Candidate Gateway. For example, if you edit an offer and generate a new offer letter, the new offer letter is immediately visible in Candidate Gateway. The original offer letter also remains visible unless you remove it from the offer.</p> <p>To avoid deleting old offer letters, unpost the old offer, then create and post a revised offer. .</p>

## Job Offer Components

The compensation package for an offer is made up of one or more job offer components such as base salary, bonuses, stock options, car or meal allowances, and so forth. Every offer must include at least one offer component. The system has these restrictions on modifying components of pay for a posted offer:

- If a posted offer is in *Accept* status (or whatever status is configured as the complete status for offers), you cannot modify the offer components.
- If a posted offer is in a status other than *Accept*, the system displays a warning if you modify the offer components, but it does not prevent you from making the change.

**Note:** If approvals are active and the offer is in a pending status or open status, modifying components of pay (or other offer data) re-triggers the approval process.

<b>Field or Control</b>	<b>Description</b>
<b>Component</b>	Select an offer component. These are compensation elements that you configure on the <a href="#">Job Offer Component Page</a> .
<b>Offer Amount</b>	Enter an amount. If the offer component is configured as base compensation, the system warns you if the amount is above or below the recommended salary range.
<b>Payment Mode</b>	Displays the payment mode associated with the selected component. Values include <i>Cash, Leaves, Meal Voucher, Non Cash, and Stock Options</i> .
<b>Currency</b>	Select the currency. The default value comes from the job offer component.
<b>Frequency</b>	Select a pay frequency. The default value comes from the job offer component.
<b>Add Offer Component</b>	Click to add a new row to the Job Offer Components grid.

### Recommended Salary Range

You can expand this section, which is initially collapsed, to see the salary range associated with the job code. If there is no job code, or if the job code does not have a recommended salary range, this section does not appear.

### Comments

Enter any comments related to the job offer. Offer comments are not shown on any other page.

### Offer Letter

Use this group box to create an offer letter.

See [Sending Correspondence and Recruitment Letters](#).

<b>Field or Control</b>	<b>Description</b>
<b>Letter</b>	<p>Select a template to use for the applicant's offer letter.</p> <p>The BI Publisher templates that are available to use as offer letters are those from the HRS_OFF_LET report definition.</p>
<b>Date Printed</b>	<p>Displays the date that you printed the offer letter. The system populates the field when you click the Generate Letter button or when the offer letter is generated by the HRS Letter Generation process. You cannot generate a new offer letter if there is a date in this field, but you can manually clear the date to reactivate the Generate Letter button.</p>
<b>Generate Letter</b>	<p>This button is available only if the offer is in an open status, a template is selected in the <b>Letter</b> field, and the Date Printed field is clear. The button is not available when the offer is in an editable state.</p> <p>Click this button to immediately generate a letter based on the selected template. The system opens the generated letter in a new browser window, where you can print it or save it locally. If you make changes, save the modified letter to your local disk so that you can upload the revised version.</p> <p>When you generate the letter, the system enters the current date in the <b>Date Printed</b> field and removes the letter from the HRS Letter Generation process queue. The Generate Letter button becomes inactive; to make it available again, clear the date in the Date Printed field.</p> <p>If, after generating a letter, you subsequently click the <b>Email Applicant</b> button, the system automatically attaches the generated letter to the email.</p> <p>When you generate a letter, the system creates an applicant contact note. The letter is an attachment to the note.</p> <p>If you delete the offer, or if you delete the letter from the offer attachments grid, the system does not remove the related contact note. The note still shows the deleted letter as a note attachment. However, the attachment cannot be opened from the note. A warning message that appears when an offer or an offer letter is deleted recommends that the user manually modify the related applicant note.</p> <hr/> <p><b>Note:</b> The system does not create notes for offer letters that are generated in batch.</p> <hr/>

<b>Field or Control</b>	<b>Description</b>
<b>Upload Letter</b>	<p>Click this button to upload a saved letter as an attachment. Most commonly, you use this button to upload a modified version of the original generated letter. However, it is not necessary to generate a letter before uploading one.</p> <p>Uploading a letter does not remove the original generated letter from the attachments grid, but you can remove the original letter manually if necessary.</p> <p>When you upload a letter, the system creates a contact note for the applicant. The letter is an attachment to the note.</p> <p>If you subsequently click the <b>Email Applicant</b> button, the system automatically attaches the modified letter (rather than the original) to the email.</p>
<b>Email Applicant</b>	<p>Click this button to display the Send Correspondence page. If you generated or uploaded an offer letter, the Attachments grid on the Send Correspondence page includes the offer letter, but you can remove or replace it if you wish.</p> <p>After accessing the Send Correspondence page, enter the email subject and message, then send it to the applicant. When you send the email, the system creates an applicant contact note; the email attachments are saved as note attachments.</p>

## Attachments

This section appears only if the system is configured to allow online job offers for this job opening's regulatory region. If you post a job offer on Candidate Gateway, the applicant will see all of the attachments that you include here.

The system creates rows for any offer letters that you generate or upload on this page. Offer letters that the HRS Letter Generation process creates do not get added to the grid.

Certain fields and field values relate to document definitions, which are not commonly used in recruiting. Document definitions are empty placeholders where users can add file attachments, URLs, and notes.

See [Understanding Online Job Offer Attachments](#).

---

**Note:** Before you add attachments, you must save the offer. Because saving the offer puts the offer into read-only mode, use the **Edit Offer** link to make the offer editable again so that you can add attachments. You can add and remove attachments only when the offer is editable.

---

<b>Field or Control</b>	<b>Description</b>
<b>Type</b>	Identifies the attachment as one of these: <ul style="list-style-type: none"> <li>• <i>Attachment</i>: a standard file attachment.</li> <li>• <i>URL</i>: a link that was added as an attachment using either the Add Organizational Attachment button or the Add Document Definition button.</li> <li>• <i>Note</i>: a note that was added using the Add Document Definition button.</li> </ul>
<b>Description</b>	Enter identifying information for the document. The default description for offer letters is <i>Offer Letter</i> .
<b>Details</b>	Click to display the attachment. The link text is the file name for file attachments and the URL for URL attachments.  Notes, which are added as document definitions, display the note subject.
<b>Action Required</b>	Select this check box for any items that the applicant must complete and return if the offer is accepted. In Candidate Gateway, an icon appears next to these documents, along with instructions to review the marked documents.
	Click this icon to delete an attachment.  Deleting an offer letter attachment does not remove the applicant note that was automatically created when the letter was generated. The note continues to display the offer letter as a note attachment. However, the attachment cannot be opened from the note. A warning message that appears when an offer letter is deleted recommends that the user manually modify the related applicant note.
<b>Add Applicant Attachment</b>	Click to display a Choose File dialog box, where you select a local file to upload. This button is active only when the offer is editable.

<b>Field or Control</b>	<b>Description</b>
<b>Add Organizational Attachment</b>	<p>Click to display the Organizational Attachments page, where you can select existing attachments (file attachments or URLs) to add to the offer. The attachments that appear on the Organizational Level Document page are context-dependent. For example, if an attachment is valid only for a particular business unit, then it is available only for job offers in that business unit.</p> <p>This button is active only when the offer is editable.</p>
<b>Add Document Definition</b>	<p>This button appears only if your organization has enabled document definitions for offers, and if there are document definitions that are valid in the current context. This is not common.</p> <p>Click this button to access the Document Definitions page, where you choose document definitions to add to the offer.</p>

## Organizational Level Documents Page

Use the Organizational Level Documents page (HRS\_OFF\_SELATC\_SEC) to select items from your organization's library of existing attachments and attach them to the job offer.

Navigation:

Click the **Add Organizational Attachment** button on the Prepare Job Offer page.

This example illustrates the Organizational Level Documents page.

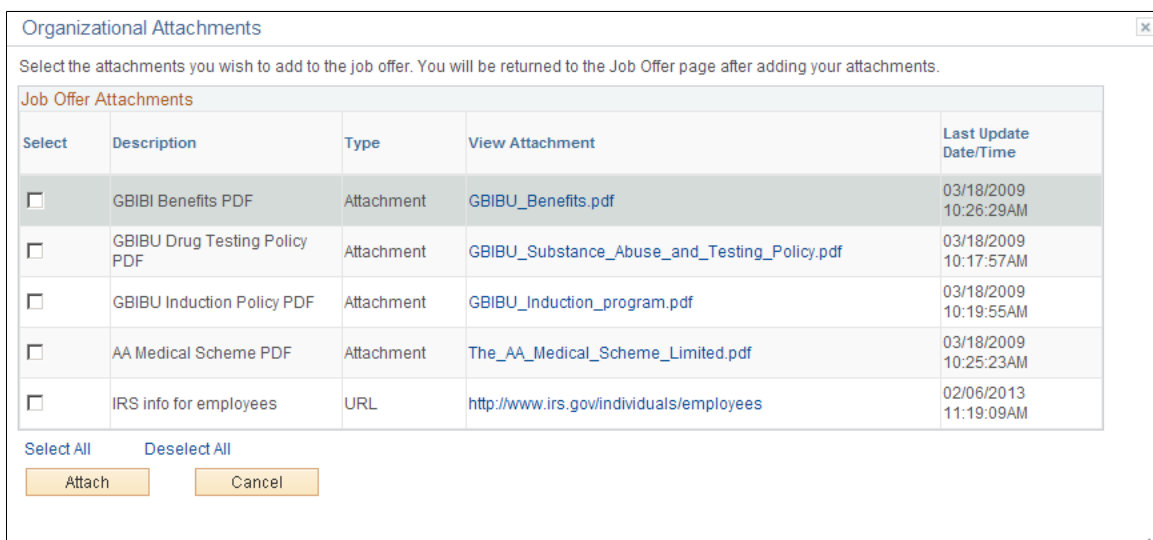

## Job Offer Attachments

The list of available attachments and URLs is context-sensitive. For example, certain attachments might be valid for some business units but not others.

<i>Field or Control</i>	<i>Description</i>
<b>Select</b>	Select one or more documents that you want to attach to the job offer.
<b>Attach</b>	Click to attach the selected documents to the job offer and return to the Prepare Job Offer page.
<b>Cancel</b>	Click to close the dialog box without adding any attachments to the job offer.

## Document Definitions Page

Use the Document Definitions page (HRS\_OFF\_SELDOC\_SEC) to add document definition attachments to an offer.

Document definitions are not typically used in recruiting.

Navigation:

Click the **Add Document Definition** button on the Prepare Job Offer page.

This button is hidden when there are no valid document definitions for this context.

This example illustrates the Document Definitions page.

**Document Definitions**

Select the type of Document Definition you wish to attach and select the Add Document Definition button to access the Existing Document Definitions page. The system will attach the document immediately to the Job Offer.

Document Definition Attachments	
	Description
<input checked="" type="radio"/>	Offer Addendums

Add Document Definition
Cancel

Document definitions are part of the PeopleSoft HCM common attachments framework. They are empty placeholders where users can add file attachments, URLs, or text notes. Because recruiters can add files attachments directly to the offer, and they can incorporate URLs and text notes into the offer letter, document definitions are not typically used in the context of job offers.

<b><i>Field or Control</i></b>	<b><i>Description</i></b>
<b>Document Definition Attachments</b>	This grid lists document definitions that are valid for the context of the job opening. Select the type of document definition that you want to add to the offer.
<b>Add Document Definition</b>	Click to access the Existing Document Definitions page for the selected document definition. Then select and attach preexisting document definition attachment or create and attach new ones.

### **Related Links**

“Configuring and Working With Attachments” (Application Fundamentals)

## **Post Online Job Offer Page**

Use the Post Online Job Offer page (HRS\_OFFER\_SEND\_SEC) to post a job offer to Candidate Gateway.

Navigation:

Click the **Post** link on the Prepare Job Offer page.



This example illustrates the Post Online Job Offer page.

**Post Online Job Offer** ✕

Review and Submit posting for this online job offer if the information is correct. To make changes, select Cancel to return to the offer page and edit the offer.

**Offer Details**

**Applicant Name** Karla Benerfer  
**Applicant ID** 300129  
**Job Opening** 503705 Radiologist - Burns Unit  
**Position Number** 19000061  
**Job Code** 740005  
**Offer Date** 08/04/2009  
**Start Date** 08/01/2010  
**Offer Expiration Date** 08/14/2009  
**Status** 010 Extend  
**Reason**

**Job Offer Components**

Component	Offer Amount	Payment Mode	Currency	Frequency
Base Salary	5678.00	Cash	USD	Monthly
Car Allowance	600.00	Cash	USD	Monthly
Annual Bonus	5000.00	Cash	USD	Annual

**Attachments**

Type	Description	Details	Action Required
Attachment	GBIBI Benefits PDF	GBIBU_Benefits.pdf	<input checked="" type="checkbox"/>
Attachment	GBIBU Drug Testing Policy PDF	GBIBU_Substance_Abuse_and_T...	<input checked="" type="checkbox"/>
Attachment	GBIBU Induction Policy PDF	GBIBU_Induction_program.pdf	<input checked="" type="checkbox"/>
Attachment	AA Medical Scheme PDF	The_AA_Medical_Scheme_Limit...	<input checked="" type="checkbox"/>
Attachment	Offer Letter	2009-08-04-18.39.03.0000001...	<input type="checkbox"/>

Review the offer details on this page, then click the **Submit** button to post the offer.

When the offer is posted, the system generates a Candidate Gateway notification, sends an email to notify the applicant of the job offer, and creates a contact note.

## Approving Job Offers

This topic provides overviews of setup for offer approvals, how to approve offers, and the delivered approval process for job offers.

This topic then discusses how to approve job offers using classic approval pages or Fluid Approvals.

## Pages Used to Approve Job Offers

<i>Page Name</i>	<i>Definition Name</i>	<i>Usage</i>
<a href="#">Pending Approvals Page</a>	HRS_RECRUIT_CONSOL	View pending approvals and approve job offers.
<a href="#">Prepare Job Offer Page: Approvals Tab</a>	HRS_APP_RCMNT	Approve a job offer or add approvers or reviewers to the approval process.
<a href="#">Insert Additional Approver or Reviewer Page</a>	NA	Add approvers or reviewers to the approval process.
<a href="#">Job Offer Page for Fluid Approvals</a>	EOAWMA_TXNHDTL_FL	Approve a job offer.

## Understanding Setup for Offer Approvals

Job offer approval processes are configured using the common Approval Framework and then activated using a setting on the Recruiting Installation page.

### Approval Framework

Approval processes are defined using the common Approval Framework. Recruiting Solutions uses the *JobOffer* approval process definition, created in the Approval component, to manage approval processing for job openings.

For more information, see “Understanding Approvals” (Application Fundamentals) and “Setting Up Approval Process Definitions” (Application Fundamentals).

### Approval Process Activation

To use the approval process for job offers, select the **Job Offers** check box in the **Approvals Required** group box on the [Recruiting Installation - General Page](#).

If your organization requires works council approval for job offers, also select the **Optional Works Council** check box on the same page.

If you deactivate offer approvals when there are pending approvals:

- You can still see pending job offers on the classic Pending Approvals page, but you cannot act on them or follow the link to the Prepare Job Offer detail page.
- You can still access the Fluid Approvals page for job offers, but if you attempt to act on the offer (for example, by clicking the Approve button), an error message informs you that job offer approvals are not active.

Oracle recommends that you approve or deny all pending approval requests before deactivating approval processing for job offers.

## Using Status Change Effects to End an Approval Process

The delivered status change effects in the recruiting system include a configuration that automatically rejects offers that are in *Hold* or *Extend* status when the applicant's disposition changes to *Reject*. For example, if you close a job opening, the delivered status change effects automatically reject all applicants for the job opening, and that in turn rejects offers that have been extended for those applicants.

However, the delivered status change effects do not automatically update offers that are in *Pending Approval* status. Consider updating the status change effect configuration so that pending offers also get rejected when the applicant is rejected. Changing the offer status so it is no longer pending approval automatically terminates the approval process. Terminating the approval process removes the offer from the approver's list of pending approvals.

See [Understanding Recruiting Statuses](#), [Understanding the Delivered Status Configuration](#), and [Setting Up Recruiting Statuses](#)

## Understanding How to Approve Job Offers

This overview discusses how to act on a job offer approval request.

### Approval Pages

The following pages are available for approving job offers:

- The [Pending Approvals Page](#) under the Recruiting menu lists the job offer that require your approvals. You can act on one or more approval request directly on this page.

---

**Note:** The Pending Approvals page under the Recruiting menu is a classic page. Fluid Approvals also has a Pending Approvals page that lists pending approvals for all transactions, not just recruiting transactions.

---

- The [Prepare Job Offer Page: Approvals Tab](#) enables you to take action on the specific offer you are viewing.

The notification that the system sends to approvers includes a direct link to the Prepare Job Offer page.

- The [Job Offer Page for Fluid Approvals](#) enables you to approve offers within the common Fluid Approvals component.

For more information about Fluid Approvals, see “Using PeopleSoft Fluid User Interface Self-Service Approval Transactions” (Application Fundamentals).

### Approver Actions

Approvers have these options:

- Approving the job offer.

The system records the approval and notifies the next approver, if any. When the final approver approves the offer, the system sets the job opening status to *Extend*.

- Denying the job offer.

The system sets the job offer status to *Denied*, stops the progress of the job offer, and notifies the requester.

- Pushing back the job offer.

The system notifies the previous approver that the job offer has been pushed back and needs his or her attention.

Pushing back an offer takes a currently pending step out of pending status and requeues the previous step to its approvers. The purpose of push back is to question the prior step's approval and request clarification. Because push back only makes sense if there is a previous approver, the first approver cannot push back.

---

**Note:** Changes to the offer status can also trigger changes to other statuses. If you use the delivered status change effects, when the offer status changes to *Extend*, the applicant's disposition changes to *Offer*.

---

## Job Offer Changes

If an offer is in pending status or its default open status (as defined in your status configuration), changes to the job offer re-trigger the approval process. When the approval process is re-triggered, the system starts the approval process over with the first approver. If the offer was in its default open status, the system also puts it back into pending status.

## Approval Delegation

If you enable delegation for job offer approval, approvers can delegate approval authority to proxies for specified amounts of time. The system gives the proxy access to the Pending Approvals component, which displays the job openings for which approval has been delegated.

For more information, see [Talent Acquisition Manager Delegations](#).

## Understanding the Delivered Approval Process for Job Offers

Oracle delivers a default approval process for job offers. This process includes up to three approvers:

1. The first approver is the primary hiring manager's supervisor.

To identify the supervisor of the hiring manager, the system uses the Target Information page.

If the job offer is not associated with a job opening, you can specify a hiring manager on the Prepare Job Offer page when you create the job offer. If there is no hiring manager, then the first approval step is skipped. If the primary hiring manager's supervisor is inactive, the first approver is the supervisor of the inactive employee.

See “Setting Up Access to Direct Reports Data” (Application Fundamentals).

2. The second approver is the recruiter or recruiters for the job opening or, if the offer is not associated with a job opening, the recruiter specified on the offer.

When multiple recruiters are specified for a job opening, any one of the recruiters can approve the job offer.

If there is no recruiter on the job opening (or on the offer, for an offer without a job opening), the system routes the approval request to the recruiting solutions approval administrator.

3. If works council approvals are activated, and if the job opening is associated with a works council ID, then the works council spokesperson is the third and final approver.

The works council spokesperson is specified in the **Spokesperson** field on the Works Council Table page.

See “Setting Up Works Councils” (PeopleSoft Human Resources Manage Labor Administration).

If there isn't a works council ID tied to the job offer, or if there is no one entered in the **Spokesperson** field, the system skips this approval step.

The following diagram illustrates the delivered approval process, which includes three approvers when works council approval is needed and two approvers otherwise. The process starts when the system sends the first approver a notification at the time the offer is submitted. As each approver approves the offer, the system sends notifications to the next approver.

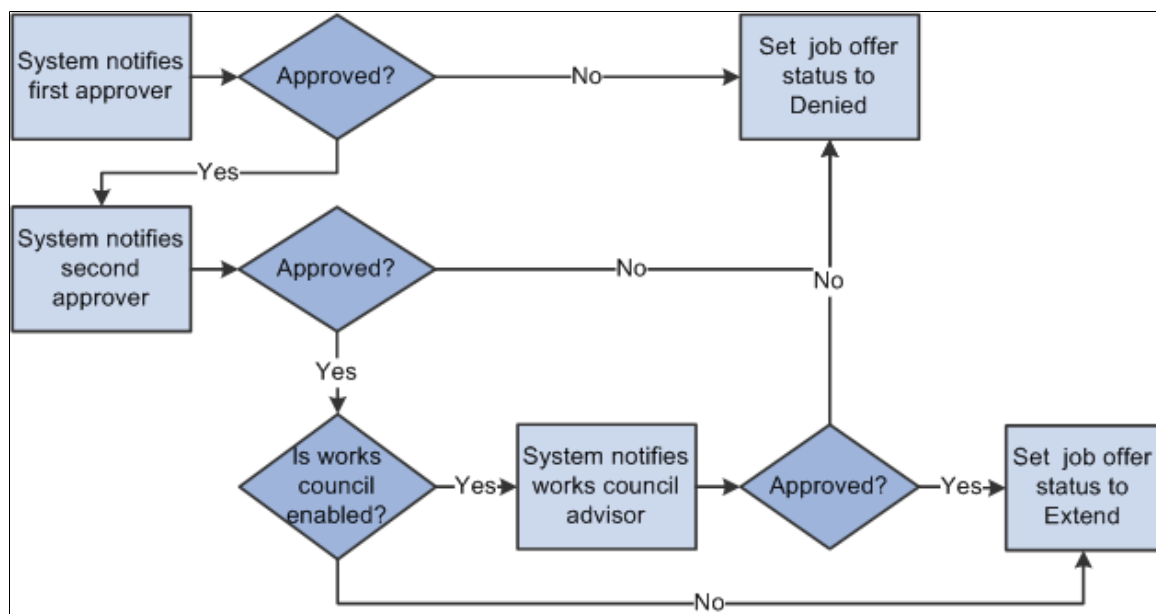

**Note:** You can modify this delivered approval process to fit your organization's business needs.

## Pending Approvals Page

Use the Pending Approvals page (HRS\_RECRUIT\_CONSOL) to view and act on pending approval requests.

Navigation:

**Recruiting > Pending Approvals**

This example illustrates the Pending Approvals page.

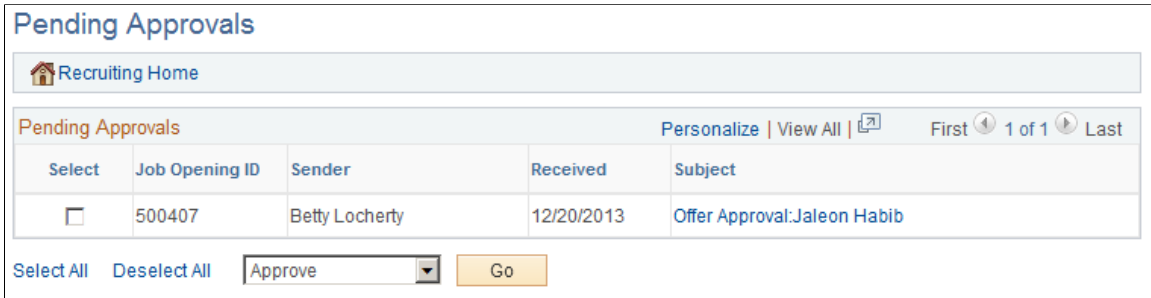

## Pending Approvals

<b>Field or Control</b>	<b>Description</b>
<b>Select</b>	<p>To approve or deny multiple pending approvals, select the check boxes for the transactions that you want to approve or deny,</p> <p>If offer approval processing has been turned off in the Recruiting Installation component, the check box for the transaction is disabled and the user cannot act on the pending approval.</p>
<b>Job Opening ID</b>	Displays the job opening ID for the transaction to be approved.
<b>Sender</b>	Displays the name of the person who submitted the offer for approval.
<b>Received</b>	Displays the date that you received the request to approve this job offer.
<b>Subject</b>	<p>Job offer approvals start with the text <i>Offer Approval</i>. Click a job offer approval link to access the Prepare Job Offer page, where you can view details and approve or deny the offer.</p> <p>If offer approval processing has been turned off in the Recruiting Installation component, the link is disabled and the user cannot access the transaction from this page.</p>
<b>&lt;Action&gt;</b>	<p>To approve or deny transactions from the Pending Approvals page, first select the transactions, then select <i>Approve</i> or <i>Deny</i> from the drop-down list box below the Pending Approvals grid, then click <b>Go</b>.</p> <p>The system approves or denies the selected transactions and removes them from the page.</p>

## Prepare Job Offer Page: Approvals Tab

Use the Prepare Job Offer Page: Approvals tab (HRS\_APP\_RCMNT) to approve, deny, or push back a job offer.

This tab is visible after a job has been submitted for approval. However, if approval processing is subsequently turned off in the Recruiting Installation component, this tab is no longer visible.

Navigation:

Click the link for a job offer transaction on the Pending Approvals page, then access the Approvals tab.

This example illustrates the Approvals tab on the Prepare Job Offer Page.

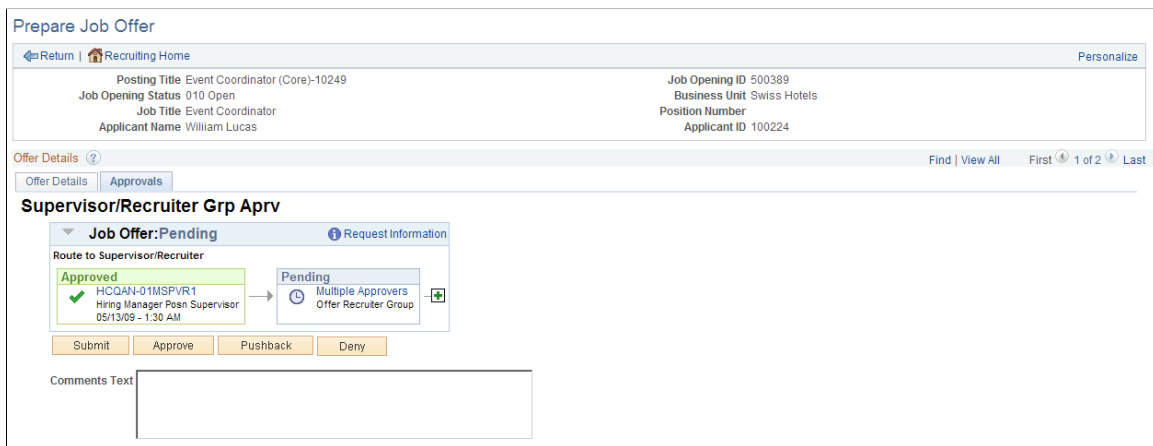

This example illustrates the fields and controls that a recruitment administrator sees on the Prepare Job Offer page: Approvals tab

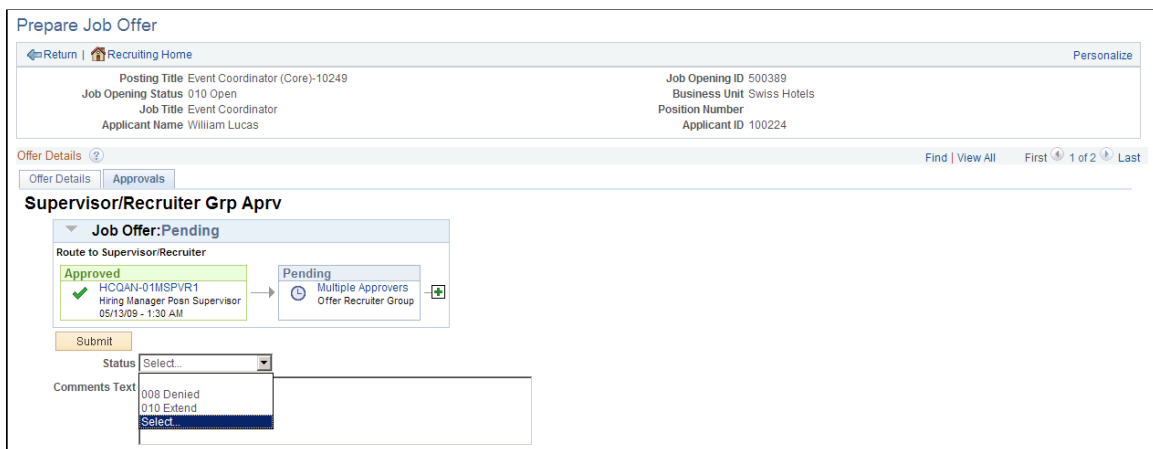

**Note:** The Approvals tab appears on the Prepare Job Offer page only after the offer is submitted for approval.

### Job Offer: <Approval Status>

This group box displays a graphical representation of the approval process. There is a box for each approver. The box title shows the approver's status, while the box contents include the approver's name,

the approver's role in the approval process (for example, the hiring manager's supervisor), and the date, if any, when the approver took action on the approval request.

Additional graphical elements in this group box include color-coding the approver boxes according to the approver's status, and status icons next to the approver's user ID.

<b>Field or Control</b>	<b>Description</b>
<Approver User ID>	Click the approver's user ID to display additional information about the approver.
	Click to add another approver or reviewer. A secondary page appears, where you select a user ID and indicate whether you are adding an <i>Approver</i> or <i>Reviewer</i> .
<b>Submit</b>	Click to save any changes to the approval process (for example, after adding an additional approver).

### Approval Controls for Assigned Approvers

The following buttons are visible only to the current approver.

<b>Field or Control</b>	<b>Description</b>
<b>Approve</b>	Click to approve the job offer. When final approval is reached, the system changes the job offer status from <i>Pending Approval</i> to <i>Extend</i> .
<b>Pushback</b>	This is available only to approvers other than the first approver.  Click to send a notification to the previous approver telling them the job offer needs to be changed.
<b>Deny</b>	Click to reject the job offer and set the job offer status to <i>Denied</i> .



## Approval Control for Administrators

<i>Field or Control</i>	<i>Description</i>
<b>Status</b>	<p>When an administrator views the approval chain, the buttons that the assigned approvers use are not visible. Instead, there is a <b>Status</b> drop-down list box that the approver can use to override the approval process. The administrator can select either <i>Extend</i> or <i>Denied</i>. The override takes effect when the administrator submits the job offer.</p> <p>After an administrator overrides the approval process, the approval process status is <i>Terminated</i>, regardless of whether the administrator approved or denied the job opening.</p>

## Insert Additional Approver or Reviewer Page

Use the Insert additional approver or reviewer page to add approvers or reviewers to the approval process.

Navigation:

Click the **Insert Approver** icon on the graphical image of the approval process on the Prepare Job Offer page: Approvals tab.

This example illustrates the Insert additional approver or reviewer page.

<i>Field or Control</i>	<i>Description</i>
<b>User ID</b>	Select the user ID of the person that you want to add.
<b>Insert as</b>	Specify whether this user is added as an approver or reviewer.

## Job Offer Page for Fluid Approvals

Use the fluid Job Offer approval page (EOAWMA\_TXNHDTL\_FL) to approve a job offer.

Navigation:

On the Manager Self-Service home page, click the Approvals tile to access the Pending Approvals page. Then click a job offer entry on the Pending Approvals page.

This example illustrates the fluid Job Offer approval page.

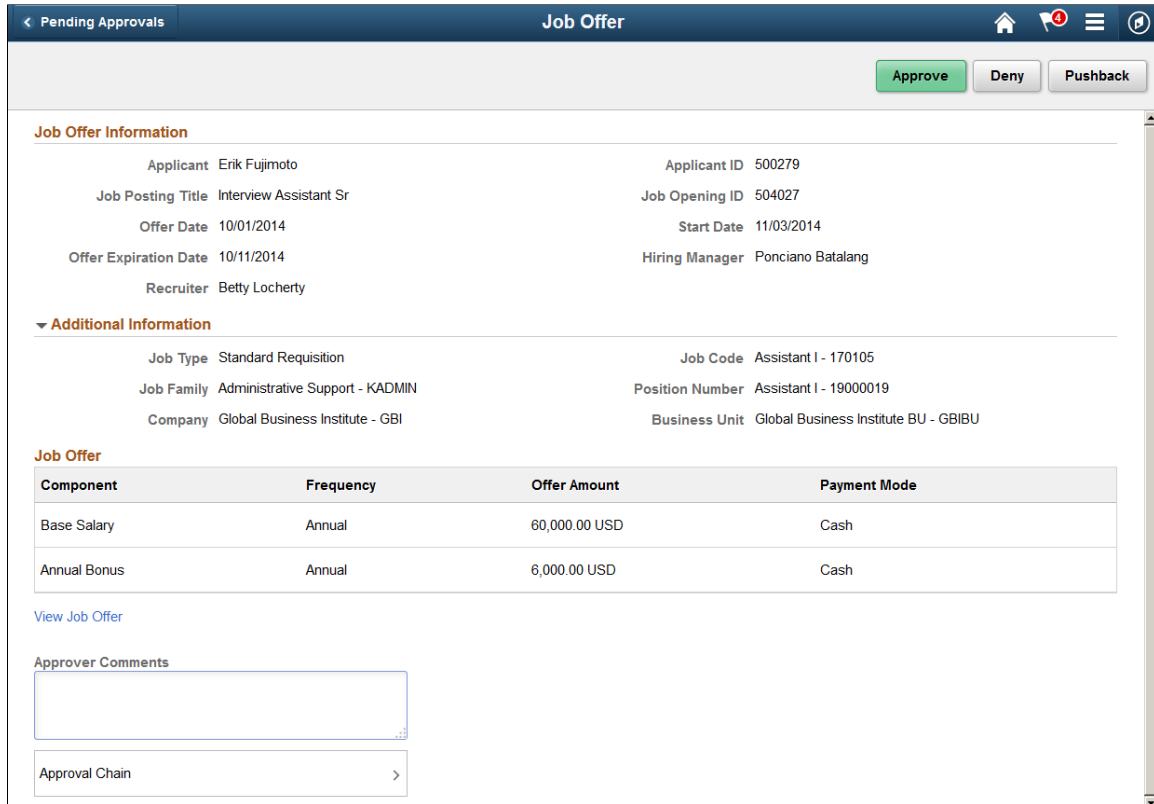

### Approval Options

The approval options on this page are common to all fluid approval transactions, as described in the documentation for the “Pending Approvals - <Transaction Details> Page” (Application Fundamentals).

<b>Field or Control</b>	<b>Description</b>
<b>Approve, Deny, and Pushback</b>	Use these buttons to take action on the requested approval.
<b>Approver Comments</b>	Enter any comments related to the approval action you take.
<b>Approval Chain</b>	Click this item to open the Approval Chain page, where you can review information about all approvers for the transaction.

### Job Offer Details

The job offer fields on this page provides information about the transaction you are being asked to approve. Fields correspond to the same-named fields on the Prepare Job Offer Page

<b>Field or Control</b>	<b>Description</b>
<b>View Job Offer</b>	Click this link to access the Prepare Job Offer page, where you can review complete offer information.

---

## Accepting and Rejecting Offers

This topic discusses how to record offer acceptance and rejection.

### Pages Used to Accept and Reject Offers

<b>Page Name</b>	<b>Definition Name</b>	<b>Usage</b>
<Accept/Reject> Offer Page	HRS_GACT_APP_ACP	Record that an offer has been accepted or rejected, and enter an optional reason.

### Understanding Offer Acceptance and Rejection

Use the Offer Status field to indicate when an offer has been accepted or rejected.

The Offer Status field is visible on the Prepare Job Offer page, where you can make direct edits to the field.

You can also update the offer status using the Accept Offer and Reject Offer actions. These actions update the offer status after prompting you for an optional reason for the status change. Both the Accept Offer and Reject Offer actions are available when the applicant has at least one offer in an open status (regardless of the applicant's disposition). If you perform the action when the applicant has more than one open offer, the system cannot know which offer to update, and it directs you to the Prepare Job Offer page where you can choose the correct offer and update the status manually.

If you post job offers to Candidate Gateway, applicants can accept and reject the offers online. These actions also update the offer status field.

All of these mechanisms for updating the offer status trigger status change effects. If you use the delivered status change effects, accepting an offer changes the applicant's disposition to *071 Offer Accepted*. Only applicants in this disposition can be prepared for hire using the Prepare for Hire action.

### <Accept/Reject> Offer Page

Use the <Accept/Reject> Offer page (HRS\_GACT\_APP\_ACP) to record that an offer has been accepted or rejected and to enter an optional reason.

---

**Note:** The page title is either **Accept Offer** or **Reject Offer**, depending on the action you use to access the page.

---

Navigation:

- Click the **Accept Offer** link or the **Reject Offer** link on the Prepare Job Offer page or on the Manage Application page: Offer tab.
- Select the Accept Offer action or the Reject Offer action from the **Other Actions** > **Recruiting Actions** , menu on any of these pages:
  - Manage Applicant page
  - Manage Job Opening page
  - Manage Application page
  - Search Applications page

These actions are available only if there is an open offer.

This example illustrates the <Accept/Reject> Offer page as it appears when you access it using the Accept Offer action.

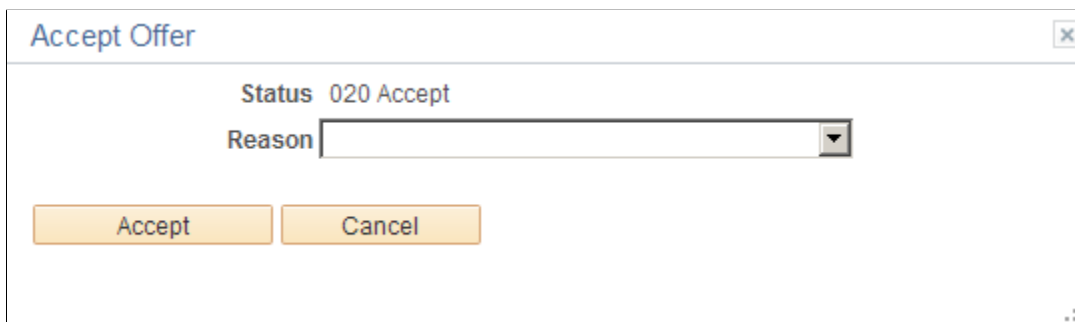

The screenshot shows a dialog box titled "Accept Offer" with a close button in the top right corner. Inside the dialog, the "Status" is set to "020 Accept". Below the status, there is a "Reason" label followed by a text input field and a dropdown arrow. At the bottom of the dialog, there are two buttons: "Accept" and "Cancel".

This example illustrates the <Accept/Reject> Offer page as it appears when you access it using the Reject Offer action.

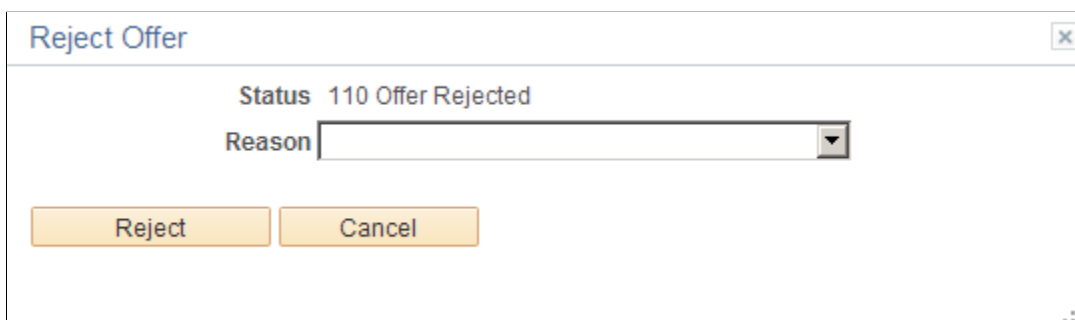

The screenshot shows a dialog box titled "Reject Offer" with a close button in the top right corner. Inside the dialog, the "Status" is set to "110 Offer Rejected". Below the status, there is a "Reason" label followed by a text input field and a dropdown arrow. At the bottom of the dialog, there are two buttons: "Reject" and "Cancel".

<b>Field or Control</b>	<b>Description</b>
<b>Status</b>	<p>Displays the offer status to be assigned.</p> <p>If you accessed this page using the Accept Offer action, the status is <i>021 Accept</i>.</p> <p>If you accessed this page using the Reject Offer action, the status is <i>110 Offer Rejected</i>.</p> <hr/> <p><b>Note:</b> Although offer status are configurable, the accept and reject actions always use these statuses, so you should not change them.</p> <hr/>
<b>Reason</b>	<p>If the status has associated reasons, you can optionally select a reason to indicate why the offer was accepted or rejected.</p>
<b>Accept</b>	<p>On the Accept Offer page, click this button to complete the offer acceptance.</p>
<b>Reject</b>	<p>On the Reject Offer page, click this button to complete the offer rejection.</p>
<b>Cancel</b>	<p>Click to return to the previous page without accepting or rejecting the offer.</p>



## Chapter 26

# Hiring Applicants

---

## Hiring Applicants

This topic provides an overview of hiring applicants and discusses how to prepare an applicant for hire.

### Pages Used to Hire Applicants

<i>Page Name</i>	<i>Definition Name</i>	<i>Usage</i>
<u>Prepare For Hire Page</u>	HRS_PREP_FOR_HIRE	Review and complete job information and submit the hire request to the HR system.
<u>Search Results Page</u>	HCR_SM_RESULTS	Review search/match results to determine whether the applicant was a former employee, contingent worker, or person of interest.
<u>Withdraw from Hire Page</u>	HRS_ACT_APP_WDRAW	Confirm that a hire request is being withdrawn, and send a cancellation request to the human resources system.

## Understanding Hiring Applicants

This overview discusses the hiring process.

### The Prepare for Hire Action

Although the actual process of hiring an applicant takes place in your human resources system, you initiate the hiring process using the Prepare for Hire action. This action displays the Prepare for Hire page, where you verify job opening data, enter a start date, and choose a hire type before sending the hiring request to human resources.

The Prepare for Hire page shows the job code or position from the offer or, if none exists, the job code or position from the job opening. If neither the offer nor the job opening has a job code or position, then you must enter at least a job code on the Prepare for Hire page.

---

**Note:** If you use full position management, then a position number is required for the job offer and when preparing to hire. If you use partial position management, then the job offer can be submitted without position or job code information, but a job code is required before you submit the applicant for hiring.

---

## Employee ID Verification

The Employee ID verification process enables you to check whether the applicant is already in the human resources database. You check by searching the database for personal data that matches the applicant's data.

This search process uses the search/match functionality in PeopleSoft Human Resources. The search uses the delivered *PSRS\_BASIC* search/match rules. You can modify the delivered rules to suit your needs.

See “Understanding Search/Match” (Application Fundamentals).

The **Employee ID Verification** field on the [Recruiting Installation – Applicants Page](#) controls whether the employee verification process is required or optional before submitting a hire request.

## Hire Processing

When you submit the hire request, the system sets the applicant's disposition to *Ready to Hire* and triggers the *HIRE\_REQUEST* message, which causes the applicant's name to appear on the “Manage Hires Page” (PeopleSoft Human Resources Administer Workforce). The system also sends notifications based on settings on the “Hire Notifications Page” (PeopleSoft Human Resources Administer Workforce). This page has separate settings for hire notifications and error notifications.

The Manage Hires page lists pending hire transactions and provides links that the human resources administrator uses to process the hire. The hire process is complete when the human resources administrator has set up both personal data and job data for the applicant.

When the applicant is hired, the HR system sends the *POST\_HIRE\_REQUEST* message to the recruiting system. The recruiting system then does the following:

- Updates the applicant record with the employee ID.
- Changes the applicant's disposition to *Hired*.

This can trigger additional status changes as well, depending on how status change effects are configured. For example, the delivered status change effects update the applicant's other job applications to a *Rejected* disposition. Status changes can also trigger notifications based on your status configuration.

- Decreases the Available Openings count for the job opening by one and changes the job opening status to *Closed* if no more openings are available.
- Copies applicant data to the newly hired employee's records in PeopleSoft Human Resources.

Profile-related data is copied into profile management records. Other data is copied into workforce administration records.

The specific data elements that are transferred depend on settings that you configure on the [Manage Hire Setup Page](#).

Salary package models for Australia are not copied during this process. Instead use the Copy Salary Package action described in the topic [\(AUS\) Copying Salary Packages to Human Resources](#).



This diagram illustrates the integration between Recruiting Solutions and Human Resources Administer Workforce during the hiring process.

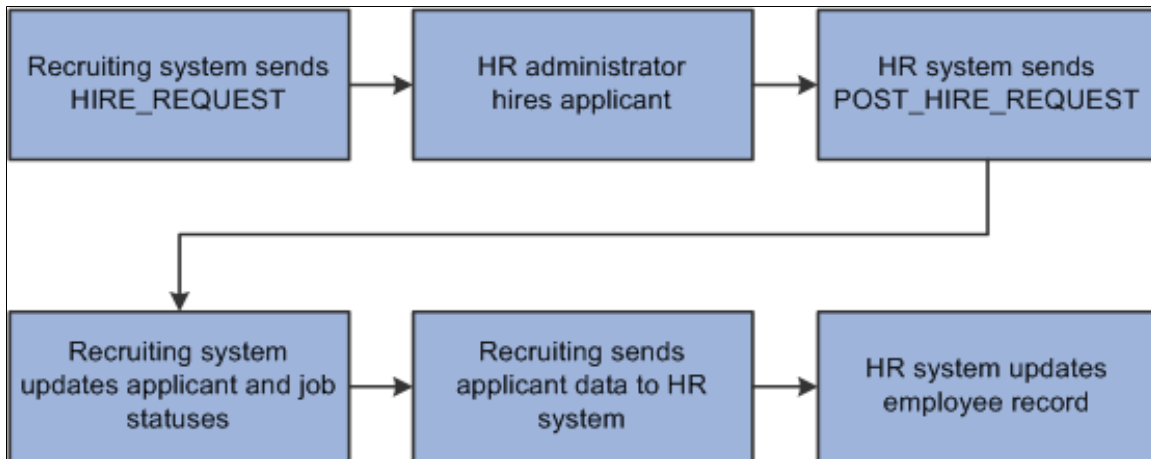

### Data Validation During the Hire Process

If there are data validation errors while transferring applicant data into HR tables, the system still saves any data that does not have validation errors. It then sends a notification with information about the errors so that the issues can be corrected. After the data issues are corrected, resubmitting the transaction completes the data transfer.

For non-profile data such as work experience and job training, the email notification includes a message that specifically describes the data issue. For profile data, however, the message in the email is generic, and the user must click a provided link to access the Integration Broker page where more detailed information is provided. Users also need to access Integration Broker to resubmit the transaction.

---

**Important!** Users who will investigate data validation issues and resubmit transactions need security access to the appropriate Integration Broker pages.

---

For example, suppose your profile setup initially includes a Language content type with a rating model to evaluate language proficiency. Later, your organization makes this rating model inactive, but applications submitted before this change still use the inactive model. When an applicant whose application references the inactive rating model is hired, the applicant's language data cannot be saved to the HR system because of the inactive rating model. The system sends a notification stating that the data is invalid. The user clicks the Integration Broker link in the email and sees that the issue is due to the inactive rating model. To complete the transaction, the user can resubmit it after making the rating model active again.

### The Withdraw From Hire Action

The Manage Hires page in the human resources system does not permit users to cancel hire requests for recruiting applicants. If it is necessary to cancel a hire request for an applicant, the cancellation request must originate in the recruiting application.

To initiate a cancellation request, use the Withdraw From Hire action for an applicant. This action is available only when the disposition is *Ready to Hire* and the job opening, if any, is in an *Open* status.

The results of the request depend on what stage the hire process has reached in the human resources system:

- If the request status is *Requested* and the applicant has not been processed at all, then the request status changes to *Cancelled* and the applicant no longer appears in the Manage Hires page.
- If the applicant has been partially or completely processed, then the request status changes to *Action Required* and a message is added to the Hire Comments field to alert the HR administrator to the situation.

Normally the Manage Hires page does not show hiring requests after the hiring administrator has finished personal data and job data processing, but the request reappears in the Manage Hires page when the cancellation requests updates the status to *Action Required*.

Regardless of what happens to the hire request in the Manage Hires page, submitting a hire cancellation request changes the applicant's disposition to *Withdrawn*.

---

**Note:** Recruiting users do not receive any messages regarding activity in the human resources system.

---

It is not possible to use the Prepare for Hire action again after you have withdrawn the applicant from hire. Each application supports only one Prepare for Hire record, and after it has been submitted once, it is permanently read-only, making it impossible to resubmit.

## Prerequisites

Before you hire applicants or withdraw hire requests, complete the following setup tasks:

1. Configure the integration broker to transfer data between the recruiting system and the HR system.
  - a. The integration broker node must be set up and active.
  - b. The application server must have the pub/sub server running, and the domain must be active.
  - c. The HIRE\_REQUEST, POST\_HIRE\_REQUEST, and WDRAW\_HIRE\_CONFIRM service operations, handlers, and routings must be active.

The HIRE\_REQUEST message passes information to the HR\_REQUEST record when you set the applicant's status to Ready to Hire.

The POST\_HIRE\_REQUEST message passes data from the human resources system back to the recruiting system after the hire is completed on the human resources side.

The WDRAW\_HIRE\_CONFIRM message passes the request to the human resources system when you withdraw an applicant from hire.

- d. The HR\_MNG\_HIRES queue status must be set to *Run*.
2. Use the Manage Hire Setup page to define the data you want to transfer from the applicant's record to the employee record.

If there is no data that is being transferred to the employee record, then the *Prepare for Hire* and *Withdraw from Hire* actions are not available.

## Prepare For Hire Page

Use the Prepare For Hire page (HRS\_PREP\_FOR\_HIRE) to review and complete job information and submit the hire request to the HR system.

---

**Note:** The *Prepare For Hire* action is available only for applicants whose disposition is *Offer Accepted*, *Ready to Hire*, *Hired*, or *Withdrawn*.

---

Navigation:

Select **Other Actions** > **Recruiting Actions** > **Prepare for Hire** on any of these pages:

- Manage Job Opening page: Applicant tab
- Manage Applicant page: Applicant Activity page: Current Status section
- Search Applications page
- Manage Application page

This example illustrates the Prepare For Hire page.

To initiate a hire, rehire, transfer, additional job assignment, or to add a contingent worker assignment, select Submit Request to HR.

Applicant ID 500268

Applicant Name Kurt Sidwell

Current Disposition 071 Offer Accepted

Disposition Date 09/04/2012

Applicant Type External - New

Application Date 06/15/2012

---

Job Opening ID  Administrative Support Supervisor

Job Opening Type Standard Requisition

Business Unit Global Business Institute BU

Department Human Resources

Position Number  Administrative Assistant

Job Code  Assistant-Administrative

---

Type of Hire

\* Start Date

Contract Number

Employee ID

Employee ID Verified Yes [Verify Employee ID](#)

Send Offer Letter to HR

Hire Comments

## Applicant Information

The read-only fields at the top of the Prepare for Hire page identify the applicant and show the applicant's disposition, disposition date, applicant type, and application date.

## Job Opening Information

<b>Field or Control</b>	<b>Description</b>
<b>Job Opening ID</b>	Identify the job opening for which the applicant is being hired. The default is the job opening for which you are performing the Prepare for Hire action, but you can change this value.
<b>Job Opening Type</b>	Displays the type of the selected job opening: <i>Standard Requisition</i> or <i>Continuous Job Opening</i> .
<b>Business Unit</b>	Displays the business unit of the selected job opening.
<b>Department</b>	Displays the department, if any, of the selected job opening.
<b>Position Number</b>	<p>Displays the position number, if any, from in the latest accepted offer.</p> <p>If there is no position in the offer, then the primary position for the job opening appears. If the job opening does not have a position number, or if it has multiple position numbers, then you can select a value for this field.</p> <p>If your system is configured to use full position management, this field is required. If your system is configured to use partial position management, this field is optional.</p>
<b>Job Code</b>	<p>Displays the job code, if any, from the latest accepted offer.</p> <p>If there is no job code in the offer, then the primary job code for the job opening appears. You can select another job code if more than one job code is associated with the job opening.</p> <p>If the hire request does not specify a job opening or a position number, enter a job code directly into this field. You cannot submit a hire request without a job code.</p>

## Additional Hire Information

<b>Field or Control</b>	<b>Description</b>
<b>Type of Hire</b>	<p>Select the type of employment. The available options depend on the applicant type.</p> <p>For external applicants you can select <i>Hire</i> and <i>Add Contingent Worker</i>.</p> <p>If the applicant is identified as a previous employee, either by the Verify Employee ID process or by the a <i>Yes</i> value in the <b>Are You A Former Employee</b> field on the <a href="#">Application Details Page</a>, then the <i>Rehire</i> option appears instead of the <i>Hire</i> option.</p> <p>For non-employee applicants (persons of interest or contingent workers), you can select <i>Hire</i> and <i>Add Contingent Worker</i>.</p> <p>For internal applicants (employees), you can select <i>Hire</i>, <i>Add Concurrent Job</i>, <i>Add Contingent Worker</i>, or <i>Transfer</i>.</p>
<b>Start Date</b>	Select the date on which the applicant is to begin work.
<b>Contract Number</b>	If you set up an applicant contract using the Manage Applicant Contracts action, this field displays the contract number.
<b>Employee ID</b>	<p>If the applicant is an employee or non-employee person of interest, this field displays the applicant's employee ID.</p> <p>If the applicant is external, this field is initially blank. If you match the applicant record to an employee record after clicking the Verify Employee ID link, the employee ID is displayed.</p>
<b>Employee ID Verified</b>	Displays <i>No</i> if you have not yet clicked the Verify Employee ID link, or <i>Yes</i> after you click the Verify Employee ID link.
<b>Verify Employee ID</b>	Click to search the human resource database to see if the applicant is a former employee, contingent worker, or person of interest. This verification helps you avoid entering the same person into the system more than once.

<b>Field or Control</b>	<b>Description</b>
<b>Send Offer Letter to HR</b>	<p>Select this check box if you want the system to include the job offer letter in the hire request message that it sends to the HR system. If multiple offers exist, the system includes the letter from the offer that is in <i>Accepted</i> status.</p> <p>If you send the job offer letter, the Manage Hires Detail page in PeopleSoft Human Resources displays a link to the offer letter.</p> <p>If you select this check box, the system confirms the existence of a job offer letter when you submit the hire request. If there is no offer letter to send, you can choose to cancel the request or to submit it without an offer letter. If you submit the request without an offer letter, the system deselects the check box.</p> <p>This check box appears only if the <a href="#">Manage Hire Setup Page</a> is configured so that the applicable hire type sends the offer letter to the HR system.</p>
<b>Hire Comments</b>	Enter any comment that you want the HR administrator to see.

### Save & Submit Request to HR

<b>Field or Control</b>	<b>Description</b>
<b>Submit Request to HR</b>	<p>This button is visible only if the applicant has not yet been prepared for hire.</p> <p>Click to submit the hire request. The system sends a notification to the HR administrator, and the applicant appears in the Manage Hires component in Human Resources Administer Workforce.</p> <p>If the <a href="#">Recruiting Installation – Applicants Page</a> is configure to require employee ID verification, and if you have not clicked the Verify Employee ID link, a message tells you that you must verify the employee ID before submitting. This message appears regardless of whether the applicant is already associated with an employee ID.</p>

### Search Results Page

Use the Search Results page (HCR\_SM\_RESULTS) to review Search/Match results to determine whether the applicant was a former employee, contingent worker, or person of interest.

Navigation:

Click the **Verify Employee ID** link on the Prepare For Hire page.

This example illustrates the Search Results page.

✕
Search/Match Results

### Search Results

**WARNING:** Potential duplicates were found - this person may already exist in the database. Refer to the list below for possible matches to the person you are adding. After you select the return button at the bottom of the page, you'll be asked whether you want to continue adding this new person, or cancel this operation.

**Match Criteria**

Required	Description	Usage	Search Value
<input checked="" type="checkbox"/>	First Name Search	Contains	KU
<input checked="" type="checkbox"/>	Last Name Search	Contains	SI
<input type="checkbox"/>	Middle Name	Contains	
<input type="checkbox"/>	Alternate Character Name	Contains	
<input type="checkbox"/>	National Id	Contains	
<input type="checkbox"/>	Date of Birth	Equals	
<input type="checkbox"/>	Address Line 1	Contains	
<input type="checkbox"/>	City	Contains	
<input type="checkbox"/>	State	Contains	
<input type="checkbox"/>	Country	Contains	

**Search Results Summary**

Number of ID's Found    2

Search Order Number    10

**Search Results**
Personalize | Find | View All | 
First 1-2 of 2 Last

		Empl ID	Last Name	First Name	Middle Name
1	<span style="border: 1px solid #ccc; padding: 2px;">Carry ID</span>	MAD0017	Singh	Mukul	
2	<span style="border: 1px solid #ccc; padding: 2px;">Carry ID</span>	MAD0095	Singh	Mukund	

Return

This is the common “Search Results Page” (Application Fundamentals) for searches performed by the search/match process. The page includes collapsible sections for reviewing the match criteria and a search results summary. The Search Results grid lists employees who meet the match criteria. Review the list for potential matches. If you are not sure whether an employee is a match, use the links on the Additional Information page to access additional information about the employee.

### Buttons

<b>Field or Control</b>	<b>Description</b>
<b>Carry ID</b>	Click to copy the employee ID to the <b>Employee ID</b> field on the Prepare for Hire page.

<b>Field or Control</b>	<b>Description</b>
<b>Return</b>	Click to return to the Prepare for Hire page without bringing over an employee ID.

## Withdraw from Hire Page

Use the Withdraw From Hire page (HRS\_ACT\_APP\_WDRAW) to confirm that a hire request is being withdrawn, and send a cancellation request to the human resources system.

---

**Note:** This action is available only for applicants whose disposition is *Ready to Hire* and job openings that are in an open status.

---

Navigation:

Select **Other Actions** > **Recruiting Actions** > **Withdraw from Hire** on any of these pages:

- Manage Job Opening page: Applicant tab
- Manage Applicant page: Applicant Activity page: Current Status section
- Search Applications page
- Manage Application page

This example illustrates the Withdraw from Hire page.

<b>Field or Control</b>	<b>Description</b>
<b>Disposition</b>	Displays the disposition to be assigned.
<b>Reason</b>	If your organization has defined reasons for the <i>Withdrawn</i> status, select the appropriate reason.



<b>Field or Control</b>	<b>Description</b>
<b>Date</b>	Displays the current date, which is also the date of the applicant's disposition change from <i>Ready to Hire</i> to <i>Withdrawn</i> .
<b>Withdraw</b>	Click to send the cancellation message to the human resources system.
<b>Cancel</b>	Click to close the page without withdrawing the applicant from the hire process.



# Using Actions for Managing Applicants

---

## Understanding Actions for Managing Applicants

This overview discusses:

- Action basics.
- Action availability.
- List of actions.

---

**Note:** This overview does not provide details about individual actions. However, the list of actions provides links to the documentation for specific actions.

---

## Action Basics

To help you process applicants, Talent Acquisition Manager provides a wide variety of predefined actions.

### Applicant Actions and Recruiting Actions

The actions that you perform in Recruiting Solutions fall into two categories:

- *Applicant actions* affect the overall applicant record rather than a specific application.  
Examples include Forward Applicant, Send Correspondence, and Link Applicant to Job.
- *Recruiting actions* relate to an application for a specific job opening (or an application without a job opening).  
Examples include Edit Disposition, Reject Applicant, and Prepare Job Offer.

### Pages Where Actions are Available

On these pages, where you see data representing applications for specific job openings (and applications without job openings), both recruiting actions and applicant actions are available:

- [Search Applications Page](#)
- [Manage Application Page](#)
- [Manage Applicant page: Applicant Activity Tab: Current Status Section](#)
- [Manage Job Opening Page: Applicants Tab](#)

On these pages (or page sections) that do not include the context of a job opening, the only available actions are applicant actions:

- [Search Applicants Page](#)
- [Manage Applicant Page](#), on the toolbar.
- [Manage Applicant List Page](#)

---

**Note:** The Edit Application Details actions presents a special case. Although it is categorized as a recruiting action, it is also available from the Search Applicants page if the user performs a keyword search or an advanced search. These searches look directly at the data from the application record, so system does not need to identify a job opening to know which application to show.

---

## Invoking Actions

The following table describes the types of page controls that can be used to invoke actions:

<i>Page Control</i>	<i>Description</i>
Toolbar Buttons	Toolbar buttons on the Manage Applicant page provide one-click access to certain actions.
Icon buttons	These provide one-click access to the most commonly used actions for a specific context.
Related action menus	<p>Click these related action menus to access context-specific lists of additional actions.</p> <ul style="list-style-type: none"> <li>• The <b>Actions</b> menu or <b>Other Actions</b> menu.</li> </ul> <p>Use these menus to perform actions on a single applicant or application. When both recruiting actions and application actions are available, these menus have <b>Recruiting Actions</b> and <b>Applicant Actions</b> submenus. The menu is called “Other Actions” in contexts where some actions are accessed using icon buttons and other actions are accessed in the menu.</p> <ul style="list-style-type: none"> <li>• The <b>Group Actions</b> menu.</li> </ul> <p>This menu appears below grids and lists the actions that you can perform on multiple grid rows. If the context supports both recruiting actions and applicant actions, the Group Actions menu has corresponding submenus.</p>

This example uses the Manage Applicant page to illustrate the different types of page controls that you use to perform actions.

- The toolbar includes buttons for actions such as **Add Note**, **Add to List**, and **Change Status** actions. Clicking the scroll control after the last visible button displays additional action-related buttons.
- The Applicant Activity grid includes icon buttons for the **Mark Reviewed**, **Route**, **Interview**, and **Reject** actions.
- The Applicant Activity grid also includes the **Other Actions** menu, which displays various actions under the **Recruiting Actions** and **Applicant Actions** submenus.
- Under the Applicant Activity grid, the **Group Actions** menu similarly lists both recruiting actions and applicant actions.

Group actions are performed on the selected grid rows.

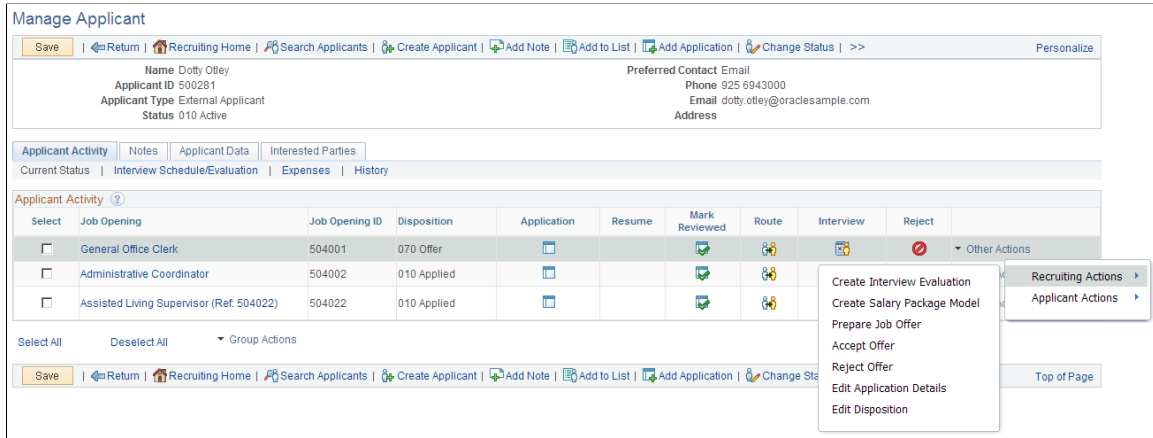

## Action Availability

The following factors control the availability of both recruiting actions and applicant actions:

- The action must be valid for the specific context, and any action-specific conditions must be met, as described in the action availability matrix in this topic.
- The user must have security access to the target page.

These additional factors affect the availability of recruiting actions:

- Unless the user is a recruiting administrator, the applicant must be in a non-draft disposition.

Although draft applications are visible in certain contexts (for example, on the Manage Applicant page), only recruiting administrators are able to perform actions on draft applications.

- The user must have security access to the job opening.

See [Job Opening Security](#).

- If a flexible recruiting process governs the job opening, it must allow the user to perform the action for applicants in the relevant disposition.

Settings on the [Actions and Roles Page](#) control action availability for a flexible recruiting process.

## List of Actions

The following table lists actions and indicates which pages provide access to each action.

For more information about a single action, refer to the documentation for the page that is accessed by the action. Refer also to the [Action Availability Reference](#), which provides a consolidated list of which pages provide access to each action.

<b>Action Name</b>	<b>Description</b>
Accept Offer	<p>Access the <a href="#">&lt;Accept/Reject&gt; Offer Page</a> to record that an offer has been accepted and to enter an optional reason.</p> <hr/> <p><b>Note:</b> This action is available only if an offer in the default (extended) or pending status exists.</p>
Add Applicant Note	<p>Access the <a href="#">Applicant Notes Page</a> to enter applicant-related notes and attachments.</p> <hr/> <p><b>Note:</b> This action is not available to users with the Hiring Manager role.</p>
Add Applicant to List	<p>Access the <a href="#">Add to Applicant List Page</a> to select the applicant list to which you want to add an applicant.</p>
Add POI (add Person of Interest)	<p>Access the <a href="#">Add Person of Interest Page</a> to create an HR person of interest record for an applicant.</p> <hr/> <p><b>Note:</b> The Applicant must be an external applicant who is not already associated with a person of interest (POI) record.</p>
Change Applicant Status	<p>Access the <a href="#">Change Applicant Status Page</a> to change an applicant's overall status (not the status specific to a job opening).</p>
(AUS) Copy Salary Package	<p>Access the “Copy Salary Package to Employee” (PeopleSoft Human Resources Administer Salary Packaging) page to copy applicant salary packages to the Employee Salary Package component.</p> <p>See also <a href="#">(AUS) Copying Salary Packages to Human Resources</a>.</p> <hr/> <p><b>Note:</b> Global Payroll for Australia must be active, the applicant must be in the Hired disposition, the salary package must not have been already copied to HR, and the user must be a recruitment administrator.</p>
Create Interview Evaluation	<p>Access the <a href="#">Interview Evaluation Page</a> to create, update, or review interview evaluations.</p>
(AUS) Create Salary Package Model	<p>Access the “Applicant Salary Package - Applicant Model Page” (PeopleSoft Human Resources Administer Salary Packaging) to model a salary package for an applicant.</p> <p>See also <a href="#">(AUS) Creating Salary Packages</a>.</p> <hr/> <p><b>Note:</b> Global Payroll for Australia must be active and the user must be a recruitment administrator.</p>
Edit Application Details	<p>Access the <a href="#">Application Details Page</a> to review or update an applicant's complete job application details.</p>

<b>Action Name</b>	<b>Description</b>
Edit Disposition	<p>Access the <a href="#">Edit Disposition Page</a> to manually change an applicant's disposition for a specific job opening (or for an application with no job opening).</p> <hr/> <p><b>Note:</b> If, under a flexible recruiting process, an applicant's current disposition does not have any valid transitions for a particular recruiting role type, then users with that role type do not see the Edit Disposition action for that applicant.</p> <hr/>
Forward Applicant	<p>Access the <a href="#">Forward Applicant Page</a> to forward applicant information (including the applicant's resume) to another person.</p>
Invite Application	<p>Send an employee an email invitation to apply for a job opening.</p> <hr/> <p><b>Note:</b> This action is available from a profile search that matches employees to job openings.</p> <hr/> <p>See also <a href="#">Search Applicants Page: Profile Match Tab</a>.</p>
Link Applicant to Job	<p>Access the <a href="#">Link Applicant to Job Opening Page</a> to link an applicant to one or more job openings.</p>
Manage Applicant Checklists	<p>Access the <a href="#">Applicant Checklist Page</a> to use a checklist to manage applicant-related activities.</p>
Manage Applicant Contracts	<p>Access the <a href="#">Contract Status/Content Page</a> to create or manage a contract that can eventually be transferred to the PeopleSoft Human Resources system if the applicant is hired.</p> <hr/> <p><b>Note:</b> This action is not available to users with the Hiring Manager role.</p> <hr/>
Manage Interviews	<p>If you invoke the action for a single applicant who has at least one existing interview, this action displays the <a href="#">Manage Interviews Page</a>, where you can view and manage existing interviews or add an additional interview.</p> <p>If you invoke the action for multiple applicants or for an applicant who does not yet have any interviews, this action displays the <a href="#">Interview Schedule Page</a> so that you can schedule interviews.</p>
Mark Reviewed	<p>Update the application disposition to <i>Reviewed</i>. The change happens immediately, and you remain on the page where you invoked the action.</p>
Merge Applicant	<p>If you invoke the action for a single applicant (using the toolbar on the Manage Applicant page), this action displays the <a href="#">Merge Applicant Page</a>, where you can merge the selected applicant record with one or more other applicants that you identify.</p> <p>If you invoke this action as a group action on the Manage Job Opening page (using the Group Actions menu on the Applicants tab, or using the Merge button on the Screening Results section of the Applicant Screening tab), this action displays the <a href="#">Review Duplicate Applicants Page</a> where you can identify the source and target applicant records and perform the merge.</p> <hr/> <p><b>Note:</b> This action is not available to users with the Hiring Manager role.</p> <hr/>

<b>Action Name</b>	<b>Description</b>
Pre-Employment Check	Access the <a href="#">Pre-Employment Check Page</a> to submit a request for a pre-employment check for an applicant.
Prepare for Hire	<p>Access the <a href="#">Prepare For Hire Page</a> to submit a hire request to the HR system.</p> <hr/> <p><b>Note:</b> Available only when the disposition is <i>Offer Accepted</i>, <i>Ready to Hire</i>, <i>Hired</i>, or <i>Withdrawn</i>.</p> <hr/>
Prepare Job Offer	Access the <a href="#">Prepare Job Offer Page</a> to create and manage a job offer.
Print Application Details	<p>If you click the Print icon or toolbar button for a single application, the action displays the <a href="#">Application Report Options Page</a>.</p> <p>If you use the Group Action menu to invoke the Print Application Details action, the action displays the <a href="#">Print Applications Page</a>.</p> <p>Both pages enable you to generate the Application Details report and to choose what content to include in the report.</p>
Reject Applicant	Access the <a href="#">Reject Applicant Page</a> to update an applicant's disposition to show that the applicant has been rejected.
Reject Offer	<p>Access the <a href="#">&lt;Accept/Reject&gt; Offer Page</a> to record that an offer has been rejected and to enter an optional reason.</p> <hr/> <p><b>Note:</b> This action is available only if an offer in the default (extended) or pending status exists.</p> <hr/>
Route Applicant	<p>If you invoke the action for an application that has at least one existing routing, this action displays the <a href="#">Manage Routings Page</a>, where you can view and manage existing routings or add an additional routing.</p> <p>If you invoke the action for multiple applicants, or for an applicant who does not yet have any routings, this action displays the <a href="#">Route Applicant Page</a> so that you can route the applicant.</p>
Send Correspondence	Access the <a href="#">Send Correspondence Page</a> to send ad hoc letters and emails to applicants.
Withdraw Application	<p>Access the <a href="#">Withdraw Application Page</a> to update an applicant's disposition to show that the application has been withdrawn from consideration.</p> <hr/> <p><b>Note:</b> Available only when the current disposition has <i>130 Withdrawn Application</i> as a successor disposition.</p> <hr/>
Withdraw from Hire	<p>Access the <a href="#">Withdraw from Hire Page</a> to send a hire cancellation request to the human resources system and update the applicant's disposition accordingly.</p> <hr/> <p><b>Note:</b> Available only when the disposition is <i>Ready to Hire</i>, the job opening, if any, is in an <i>Open</i> status, and the data transfer to HR is turned on.</p> <hr/>



## Linking Applicants to Job Openings

This topic provides an overview of how to link applicants to job openings and discusses how to link applicants to job openings.

### Page Used to Link Applicants to Job Openings

<i>Page Name</i>	<i>Definition Name</i>	<i>Usage</i>
<a href="#">Link Applicant to Job Opening Page</a>	HRS_GACT_RCM_STS	Link an applicant to a job opening.

### Understanding How to Link Applicants to Job Openings

If you find an applicant who is qualified for a specific job opening and should be considered, you can link the applicant to that job opening.

#### Establishing Links Between Applicants and Jobs

The link between an applicant and a job is what causes the job opening to appear on the Manage Applicant page and the applicant to appear on the Job Opening page.

Applicants are automatically linked to job openings when they apply for the job using Candidate Gateway or when a recruiter uses the Application Details page to add job openings to the applicant's application.

You can also link applicants to jobs by invoking the *Link Applicant to Job* action. When you link an applicant to a job using this method, the system displays the Link to Job Opening page. Use this page to specify one or more job openings to which the applicants are to be linked and to specify the initial disposition to use. You can link applicants to jobs using any non-draft disposition.

If multiple applications exist for an applicant, the job opening is added to the most recent application. The system adds a new row to the list of job openings in the application. If a blank row (for an application without a job opening) exists, it is not affected by the linking action, and the applicant continues to have an application without a job opening. To list the new job opening in the blank row (thus replacing the application without a job opening), use the Edit Application Details action instead.

#### Linked Jobs and Candidate Gateway

Applicants who are registered users of Candidate Gateway can view a list of their applications on the “My Activities Page” (PeopleSoft Candidate Gateway) (Classic Candidate Gateway) or the “My Job Applications Page” (PeopleSoft Candidate Gateway) (Fluid Candidate Gateway).

The list of applications that applicants see includes job openings that were linked to the applicant from within Talent Acquisition Manager (either by directly editing the application or through the Link Applicant to Job action). The Candidate Gateway page lists these applications with the status *Submitted*, and the applicant is not able to modify the application. An applicant who wishes to provide additional information for a linked job opening can reapply.

## Understanding Questionnaires in Linked Jobs

Because submitted applications are never editable in Candidate Gateway, an applicant who has been linked to a job with a questionnaire cannot edit the existing application to answer the questions. Instead, the applicant is invited to create a new application, effectively reapplying for the job opening that is already linked to the applicant's record.

Because the applicant has been explicitly invited to apply, the applicant is permitted to create a new application even if the Candidate Gateway site is configured not to allow multiple applications for the same job opening.

An applicant who uses Candidate Gateway to reapply ends up with two applications for the same job opening. The applicant can see both applications in Candidate Gateway, and both application appear on the Manage Applicant and Manage Job Opening pages in Talent Acquisition Manager.

### Invitation to Answer a Questionnaire

When a user links an applicant to a job opening either by using the *Link Applicant to Job* action or by adding the job opening on the Application Details page, the system determines whether the job opening includes screening questions. If it does, the system does the following:

- Sends an email inviting the applicant to use Candidate Gateway to submit a new application for the job opening.

A link in the email takes the applicant to Candidate Gateway, where the applicant can sign in to an existing account or create a new account that will be automatically be associated with the existing applicant record.

When an applicant is linked to multiple job openings at once, the system sends only one email per applicant.

---

**Important!** Be sure the text of your email notification gives the applicant clear instructions for reapplying.

---

- Creates a contact note with a record of the outgoing email.
- Creates a Candidate Gateway notification (a message that the applicant sees after signing in to Candidate Gateway).

The notification subject is *You are invited to apply for a job: <job posting title and ID>*. Clicking the notification subject displays the posting description, and the applicant can click the **Apply** button to begin the application process.

- Adds the invitation to the *Questionnaire Requests* alert in the [My Alerts Pagelet](#) on the Recruiting Home page.

This alert is personalized, so it is shown only to user who are on the job opening's hiring team. Users can click the alert summary to access a detailed list of outstanding invitations to apply. The alert is removed when the applicant submits the new application.

### Limitations on Sending Invitations

The request to answer questions is sent only if the job is posted and the applicant has provided an email address. If the job isn't posted, or the applicant doesn't have an email address, the applicant is still linked

to the job opening, but the system does not send an email, create a contact note, or create a Candidate Gateway notification.

When you link applicants to job openings using the *Link to Job Opening* action, the Link to Job Openings page displays information about which applicants do not have email addresses and therefore will not receive the notification.

When you link applicants to unposted jobs, a warning message informs the user that the system will not email an invitation to apply.

## Link Applicant to Job Opening Page

Use the Link Applicant to Job Opening page (HRS\_GACT\_RCM\_STS) to link an applicant to a job opening.

Navigation:

- Select Link Applicant to Job (or **Applicant Actions** > **Link Applicant to Job**) from the row-specific action menu or the group action menu on any of these pages:
  - Search Applicants (all types of searches)
  - Search Applications
  - Manage Application
  - Manage Job Opening
- Click the **Link to Job** toolbar button on the Manage Applicant page.
- Click the **Link to Job** icon or use the Link Applicant to Job group action on the Manage Applicant List page.

This example illustrates the Link to Job Opening page.

**Link Applicant to Job Opening**

Applicants without email addresses will not receive a Job Opening Questionnaire.

**Applicants to be Linked**

Applicant	Name	Status	Email Address
34	John Lund	010 Active	HCMGENUser1@ap6023fems.us.oracle.com

**Job Openings**

Job Opening ID	Posting Title	Job Posted	Questionnaire
504030	Sales Product Consultant	Yes	Yes

**Disposition Information**

\*Disposition

Reason

Date 09/06/2017

### Applicants To Be Linked

<b>Field or Control</b>	<b>Description</b>
<b>Applicant</b>	<p>Displays the applicant ID for the applicant who is being linked to the job opening.</p> <p>This grid is prepopulated with the applicants that were selected when you initiated the <i>Link Applicant to Job</i> action. If you click the Add Applicant button, a new row is added to the grid, and you identify the applicant by entering the applicant ID in this field.</p>
<b>Name</b>	Displays the name of the applicant who is being linked to the job opening.
<b>Status</b>	Displays the status of the applicant who is being linked to the job opening, enabling users to confirm that the applicant is active.

<b>Field or Control</b>	<b>Description</b>
<b>Email Address</b>	<p>Displays the applicant's email address.</p> <p>If an applicant is linked to a job opening that includes a questionnaire, the system sends the applicant an email notification requesting that the applicant reapply for the job. Reapplying enables the applicant to answer the questionnaire.</p> <hr/> <p><b>Note:</b> Applicants without email addresses cannot receive email notifications. Therefore, when linking applicants to job openings with questionnaires, recruiters should consider other ways to notify applicants who do not have email addresses.</p> <hr/>
<b>Add Applicant</b>	<p>Click this button to add a blank row to the <b>Applicants to be Linked</b> grid, then enter the Applicant ID to identify the applicant.</p>

## Job Openings

<b>Field or Control</b>	<b>Description</b>
<b>Job Opening ID</b>	<p>Select the job openings to which you want to link the applicant. If you access this page from the Applicant Search tab of the Manage Job Opening page, the system creates a row for the current job opening ID.</p> <p>Security prevents you from adding any job openings that you do not already have permission to access.</p> <p>See <a href="#">Job Opening Security</a>.</p>
<b>Posting Title</b>	<p>Displays the primary posting title of the job opening.</p>
<b>Job Posted</b>	<p>Displays <i>Yes</i> if there is an active posting for the job opening or <i>No</i> if there is not.</p> <p>The system displays a warning if you link applicants to unposted job openings. You can choose whether to continue or cancel.</p> <hr/> <p><b>Note:</b> Notifications asking applicants to reapply to job openings with questionnaires include a link to the Candidate Gateway job posting. Therefore, if the job is not posted, no email is sent.</p> <hr/>

<b>Field or Control</b>	<b>Description</b>
<b>Questionnaire</b>	<p>Displays <i>Yes</i> if the job opening includes a Skills and/or Employment questionnaire or <i>No</i> if it does not. A job opening has a questionnaire if it is associated with any questions, regardless of whether the questions are used in screening.</p> <p>When you link an applicant to a posted job opening with a Skills and/or Employment questionnaire, the system sends the applicant an email with directions for signing on to Candidate Gateway and submitting an application for the job. The questionnaire is embedded in the online application.</p> <p>When linking to job openings with questionnaires, pay particular attention to:</p> <ul style="list-style-type: none"> <li>• Whether the applicants have email addresses so that they can receive the notification.</li> <li>• Whether the job opening is posted. When the job is not posted, no email is sent.</li> <li>• The disposition you assign for the linked job opening: use disposition 019 (Linked Questionnaire).</li> </ul>

### Disposition Information

Use this group box to enter the initial disposition for the applicants with regard to the job openings to which they are being linked.

<b>Field or Control</b>	<b>Description</b>
<b>Disposition and Reason</b>	<p>Select a disposition and an optional reason to assign for all linkages that you are creating.</p> <p>The default disposition is the one with the identifier <i>015</i>. The delivered label for this disposition is <i>015 Linked</i>.</p> <p>If you are linking applicants to a job that has a questionnaire, change the disposition to status code <i>019</i>. The delivered label for this disposition is <i>019 Linked Questionnaire</i>. This disposition indicates that the application does not include the job opening's questionnaire, which can only be completed when the applicant applies using Candidate Gateway. If the applicant reapplies based on the invitation that the system sends, the new application remains separate from the original linked application, and both the applicant and the recruiter see two separate applications for the job opening.</p> <p>Using the <i>019 Linked Questionnaire</i> disposition for a job opening that doesn't have a questionnaire, or using any other disposition for a job opening that does have a questionnaire, causes the system to issue a warning when you click the Link button.</p>
<b>Date</b>	Displays the current date. The applicant is linked to the job as of this date.

## Buttons

<b>Field or Control</b>	<b>Description</b>
<b>Link</b>	Click to complete the linking action. A warning message appears if any of the included applicants have an <i>Inactive</i> status.
<b>Cancel</b>	Click to return to the previous page without linking any applicants to job openings.

---

## Editing Dispositions

This topic provides an overview of manual disposition changes discusses how to edit a disposition.

## Page Used to Edit Dispositions

<i>Page Name</i>	<i>Definition Name</i>	<i>Usage</i>
<a href="#">Edit Disposition Page</a>	HRS_APP_DISP	Manually change an applicant's disposition for a specific job opening (or for an application with no job opening).

## Understanding Manual Disposition Changes

Dispositions identify an applicant's status with regard to the recruiting process for a particular job opening (or for an application with no job opening). Actions for reviewing, screening, interviewing, making offers, and hiring automatically assign appropriate dispositions.

Sometimes, however, it is necessary to manually update an applicant's disposition. To do this, use the Edit Disposition action.

### Successor Dispositions and Flexible Recruiting Processes

The [Status Successors Page](#) defines valid successors for every disposition. If a user manually updates an applicant's disposition to one that is not configured as a successor, the system displays a warning. The user can choose to ignore the warning and save the new disposition anyway.

To prevent users from performing specific manual disposition changes, implementers use a flexible recruiting process to define a limited set of valid successor dispositions based on the user's role and the applicant's current disposition. For example, an organization might allow recruiters, but not hiring managers, to manually move an applicant from the *Applied* disposition to the *Reject* disposition.

Flexible recruiting processes allow users to move applicants both forward and backward in the recruiting process. This means that the Edit Disposition action lists both predecessor and target dispositions as available options. For example, if *Reviewed* is a target of *Applied*, then the Edit Disposition page for applicants who are currently in the *Reviewed* disposition includes *Applied* as a possible new disposition, along with the dispositions that are configured as targets of *Reviewed*.

Flexible recruiting processes can also define different transition rules for different types of applicants (internal, external, and nonemployees).

If an applicant's current disposition does not have any valid transitions for a particular recruiting role type, then users with that role type do not have access to the Edit Disposition action for that applicant. For example, if hiring managers have no valid target dispositions for applicants in an *Offer* disposition, then hiring managers will not see the Edit Disposition action for applicants in the *Offer* disposition.

---

**Note:** Flexible recruiting processes do not prevent the system from updating dispositions as part of other processing. In particular, if a user has access to an action that updates a disposition, the user can perform that action even if the resulting disposition change would not have been permitted by the Edit Disposition action. For example, if your recruiting process for the *Applied* disposition gives hiring managers access to the Reject action, then hiring managers can still reject applicants even if *Reject* is not a permitted transition.

---

See [Setting Up Flexible Recruiting Processes](#).



## (JPN) Understanding Dispositions Used to Track Selectees for Japan

The standard PeopleSoft recruitment process begins with posting job openings and ends with hiring, when applicants become employees. In between job opening posting and hiring, there are the other recruitment activities, such as screening, interviewing, and offering and accepting employment.

The recruitment process followed by most Japanese companies, however, uses *selectee* dispositions between applicant and employee when processing new graduates. The new graduates become known as selectees when they have one of these four user-maintained dispositions related to preliminary offers:

- *Preliminary offer decided*
- *Preliminary offer notified*
- *Preliminary offer accepted*
- *Preliminary offer rejected*

Hire Decided is a fifth user-maintained disposition; when it is applied, the applicant is no longer considered a selectee. You manually enter the Hire Decided disposition when an applicant who has accepted a preliminary offer is about to be hired. The disposition of *Preliminary Offer Accepted* remains until that decision is made because it is possible that an applicant who has accepted might not in fact graduate and may not, therefore, be hired. The *Hire Decided* disposition distinguishes between those who have accepted and might be hired and those who have accepted and will be hired.

This flowchart illustrates the common additional Japanese recruitment stages for preliminary offers within the context of the standard recruitment process. The flowchart represents an organization that includes an acceptance letter with its version of a preliminary offer letter for the selectee to use when responding:

This diagram illustrates how the dispositions used to track preliminary offers for Japan fit into the overall recruiting process.

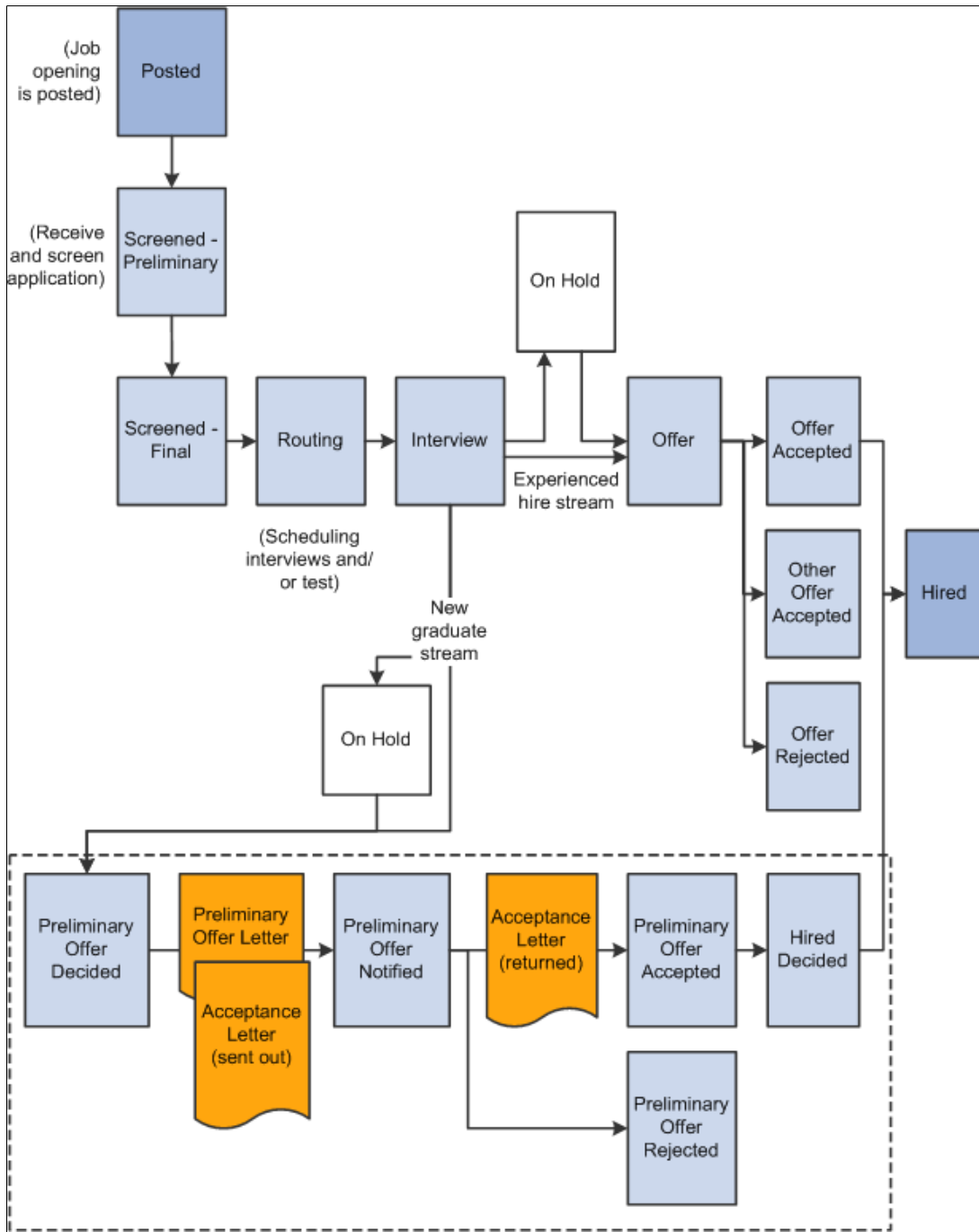

## Edit Disposition Page

Use the Edit Disposition page (HRS\_APP\_DISP) to manually change an applicant’s disposition for a specific job opening (or for an application with no job opening).

Navigation:

Select **Recruiting Actions** > **Edit Disposition** from the Other Actions menu on any of these pages:

- Manage Applicant
- Search Applications
- Manage Application
- Manage Job Opening

This example illustrates the Edit Disposition page.

<b>Field or Control</b>	<b>Description</b>
<b>Current Disposition</b>	Displays the applicant’s current disposition for the selected job opening (or application with no job opening).
<b>New Disposition</b>	Select the disposition to assign. If a flexible recruiting process governs the job opening, the available dispositions can be limited based on the applicant’s current disposition and the user’s role. Otherwise, all dispositions are available for selection.
<b>Status Reason</b>	After selecting a new disposition, optionally select a reason for assigning the disposition. The reasons that are available for specific dispositions are configured on the <a href="#">Recruiting Status and Reason Page</a> .
<b>Date</b>	Displays the current date, which is used when recording the disposition change. Disposition change history is visible on the <a href="#">Manage Applicant Page: Applicant Activity Tab: History Section</a>
<b>Save</b>	Click to save the disposition change and return to the page where you invoked the Edit Disposition action.
<b>Cancel</b>	Click to return to the page where you invoked the Edit Disposition action without changing the applicant’s disposition.

---

## Rejecting Applicants

This topic discusses how to reject applicants.

### Page Used to Reject Applicants

<i>Page Name</i>	<i>Definition Name</i>	<i>Usage</i>
<u>Reject Applicant Page</u>	HRS_GACT_APP_REJ	Update an applicant's disposition to show that the applicant has been rejected.

### Reject Applicant Page

Use the Reject Applicant page (HRS\_GACT\_APP\_REJ) to update an applicant's disposition to show that the applicant has been rejected.

---

**Note:** If a job opening is governed by a flexible recruiting process, that process controls the availability of the Reject Applicant action. Availability can vary depending on the user's role and the applicant's current disposition.

---

Navigation:

Click the **Reject** icon, or select **Recruiting Actions** > **Reject Applicant** from the Group actions menu, on any of these pages:

- Manage Applicant
- Search Applications
- Manage Application (group action not applicable)
- Manage Job Opening

This example illustrates the Reject Applicant page.

Reject Applicant			
Applicant to Reject			
Applicant ID	Name	Job Opening	Delete
500041	Sonia Nayar	Bring Your Arbitration Experience to Labor Relations	
500010	Paulo Coelho	Bring Your Arbitration Experience to Labor Relations	

Disposition

Disposition 110 Reject

Reason

### Applicants to Reject

Each row in this grid identifies an applicant for whom you are performing the Reject Applicant action and identifies the job opening (or application without a job opening) for which the disposition is to be updated. Click the Delete icon to remove an applicant from the grid.

### Select Status

Field or Control	Description
<b>Disposition</b>	<p>Displays the disposition <i>110 Reject</i>, which is the disposition that will be applied after you submit the status change.</p> <hr/> <p><b>Note:</b> Although status codes are configurable, organizations should not change this delivered disposition because the Reject action always applies disposition 110.</p>
<b>Reason</b>	<p>Select a reason for applying the <i>Reject</i> disposition.</p> <p>Users must supply a reason if the Require Reason Upon Manual Reject field on the <a href="#">Recruiting Installation – Applicants Page</a> is set to <i>Yes</i>.</p>
<b>Reject</b>	Click to complete the disposition update
<b>Reject and Correspond</b>	Click to complete the disposition update and then open the Send Correspondence page. When you access the Send Correspondence page this way, the rejected applicants are pre-entered as correspondence recipients.

<b>Field or Control</b>	<b>Description</b>
<b>Cancel</b>	Click to return to the previous page without rejecting the applicant(s)

## Effects of Status Change

If the *110 Reject* status is configured with status change effects to update route, interview, and offer statuses, only the latest one of those three status areas will actually change when you reject an application. For example, if an application has both routings and interviews, rejecting the application can cause interview status changes, but routing statuses remain unchanged. If the application also has an offer, then the offer status can change, but the interview and routing statuses remain unchanged.

---

## Withdrawing Applications

This topic discusses the Withdraw Applicant action.

### Page Used to Withdraw an Application

<b>Page Name</b>	<b>Definition Name</b>	<b>Usage</b>
<u>Withdraw Application Page</u>	HRS_WDRAW_APPLCTN	Update an applicant's disposition to show that the application has been withdrawn from consideration.

## Understanding the Withdraw Application Action

The Withdraw Application action updates an applicant's disposition to show that the application has been withdrawn from consideration.

### Configuring Action Availability

The Withdraw Application action is available only for applications in dispositions where status *130 Withdrawn Application* has been configured as a successor on the [Status Successors Page](#). As delivered, the following dispositions are configured this way:

- 005 Draft
- 010 Applied
- 015 Linked
- 019 Linked Questionnaire
- 020 Reviewed
- 030 Screen

- 050 Route
- 060 Interview
- 070 Offer
- 071 Offer Accepted
- 100 Hold

Note that dispositions after *060 Interview* are delivered with the Applicant Withdrawal check box deselected on the [Recruiting Status Area Page](#). Under this configuration, the Withdraw Application action is available for more dispositions in Talent Acquisition Manager than in Candidate Gateway.

The Withdraw Application action is never available for the dispositions *080 Ready to Hire* and *090 Hired*, regardless of your successor configuration. This prevents users from withdrawing an application after hire processing data has already been sent to Human Resources. Instead, use the Withdraw from Hire action for applicants in *080 Ready to Hire* status. You cannot withdraw an application for an applicant in *090 Hired* status.

Status successors do not affect a user's ability to use the Edit Disposition action to manually change the disposition to *130 Withdrawn Application*. As with any manual disposition change, the system displays a warning if a user manually updates an applicant's disposition to one that is not configured as a successor. However, the user can choose to ignore the warning and save the new disposition anyway.

---

**Note:** If a flexible recruiting process governs the job opening, the flexible process can affect whether a user sees the Withdraw Application action and whether the user is able to manually assign the *130 Withdrawn Application* disposition.

---

## Draft Applications

Recruiting administrators are the only users who can perform actions on draft applications. When a recruiting administrator performs the Withdraw Application action on a draft application, the system performs a logical delete (but not a physical delete) of the application. The application is no longer searchable or visible on any recruiting pages.

If the draft application is an applicant's only application, then after the application is logically deleted and the search indexes are rebuilt, the applicant is no longer searchable or visible either.

if a draft application is withdrawn using Edit Disposition the application will not be considered a logical delete. The application will remain visible in the system with the assigned disposition.

## Non-Draft Applications

Non-draft applications remain visible after they are withdrawn. As delivered, the *130 Withdrawn Application* disposition is part of the Reject phase, and this is where the applications are counted in the phase filter on the Manage Job Opening page.

## Withdrawn Applications in Candidate Gateway

When an application is withdrawn, the following changes occur in Candidate Gateway:

- A draft application that is withdrawn is no longer visible on the My Activities page in Candidate Gateway.

- A non-draft application that is withdrawn is still visible in Candidate Gateway, but it appears with the status *Withdrawn* and applicant cannot click the application to view details.

An application that was originally submitted as part of a multi-job application in Candidate Gateway does not change to status *Withdrawn* unless the applications for all of the included jobs were withdrawn.

- Any interview notifications that were associated with the withdrawn application are no longer visible in Candidate Gateway.
- Any online job offers and offer notifications that were associated with the withdrawn application are no longer visible in Candidate Gateway.
- Any resume that was associated with the withdrawn application (and is not also associated with a still active application) is no longer visible on the My Activities page and is no longer available for selection in future applications.

The resume remains visible in Talent Acquisition Manager unless the application was a draft application and was therefore logically deleted.

- If an applicant starts a new application for a job after the previous application was withdrawn, the system does not consider the new application to be a duplicate.

This means that the system doesn't warn the applicant about the previous application, and if the site is configured not to allow multiple applications for the same job opening, the applicant can now reapply for the job.

For information about how an applicant uses Candidate Gateway to withdraw an application, refer to the topics “Reviewing Activities and Uploading Attachments” (PeopleSoft Candidate Gateway) and “Using Fluid Candidate Gateway to Manage Applications and Attachments” (PeopleSoft Candidate Gateway).

## Withdraw Application Page

Use the Withdraw Application page (HRS\_WDRAW\_APPLCTN) to update an applicant's disposition to show that the application has been withdrawn from consideration.

Navigation:

Select **Recruiting Actions** > **Withdraw Application** from the row-specific action menu or the group action menu on any of these pages:

- Manage Applicant
- Search Applications
- Manage Application (group action not applicable)
- Manage Job Opening



This example illustrates the Withdraw Application page.

### Applicants to Withdraw

Each row in this grid identifies an applicant for whom you are performing the Withdrawn Application action and identifies the job opening (or application without a job opening) for which the disposition is to be updated.

If multiple applications are listed, you can click the Delete icon to remove an applicant from the grid. This icon is not active when the Withdraw Application action was invoked for a single application.

### Disposition

<i>Field or Control</i>	<i>Description</i>
<b>Disposition</b>	<p>Displays the disposition <i>130 Withdrawn Application</i>, which is the disposition that will be applied after you submit the status change.</p> <hr/> <p><b>Note:</b> Although status codes are configurable, organizations should not change this delivered disposition because the Withdraw Application action always applies disposition 130.</p>
<b>Reason</b>	<p>Select a reason for applying the <i>130 Withdrawn Application</i> disposition. Oracle delivers reason codes that indicate whether the application was withdrawn by a recruiter or through applicant self-service in Candidate Gateway.</p> <p>The default reason when you use the Withdraw Application action is reason code 020, <i>Recruiter Withdrawn</i>. When an applicant uses Candidate Gateway to withdraw an application, the system applies reason code 010, <i>Candidate Withdrawn</i>.</p>
<b>Withdraw</b>	Click to complete the disposition update

<b>Field or Control</b>	<b>Description</b>
<b>Withdraw and Correspond</b>	Click to complete the disposition update and then open the <a href="#">Send Correspondence Page</a> . When you access the Send Correspondence page this way, the relevant applicants are pre-entered as correspondence recipients.
<b>Cancel</b>	Click to return to the previous page without withdrawing the application.

## Effects of Status Change

If the *130 Withdrawn* status is configured with status change effects to update route, interview, and offer statuses, only the latest one of those three status areas will actually change when you withdraw an application. For example, if an application has both routings and interviews, withdrawing the application can cause interview status changes, but routing statuses remain unchanged. If the application also has an offer, then the offer status can change, but the interview and routing statuses remain unchanged.

---

## Printing Application Details

This topic describes how to generate and print the application details report for a single application or for a group of applications.

The following videos include demonstrations of printing applications:

Video: [View/Print Application Video Feature Overview](#)

Video: [Image Highlights, PeopleSoft HCM Update Image 17: Talent Acquisition Management Print Application](#)

## Page Used to Print Application Details

<b>Page Name</b>	<b>Definition Name</b>	<b>Usage</b>
<a href="#">Application Report Options Page</a>	HRS_PRNT_APPLN	Choose printing parameters then print application details for a single application.
<a href="#">Print Applications Page</a>	HRS_RUN_BTCH_APPL	Use the Print Applications page (HRS_RUN_BTCH_APPL) to choose printing parameters then run the Application Details (HRS_BTCH_APL) application engine process. This batch process prints application details for a group of selected applications.

## Understanding the Application Details Report

The Application Details report (HRS\_BIP\_APPL) BI Publisher report includes detailed information about an application. Refer to the report samples appendix in this documentation for an example of this report.

The Print Application Details icon that appears on various recruiting pages generates this report for a single application. The resulting PDF opens immediately in a new browser tab or window.

The Group Actions menu that appears on many recruiting pages enables you to print several applications at once. In this mode, the system uses the Application Details (HRS\_BTCH\_APL) Application Engine program to create the report, which you access using the Report Manager or Process Scheduler.

When you generate the report in batch, you can choose whether to separate PDF files for each application or a single concatenated PDF file. If you create a single PDF, the page numbering is continuous for the entire file rather than restarting for each application.

In both single application mode and batch mode, the system first presents a print options page. This provides several choices, including which parts of the application to include and which types of attachments to include.

The report content, including a footer with identifying information, is mostly the same regardless of whether the report printed in single application mode or in batch. The following table describes the only differences:

<b>Report Section</b>	<b>Single Application Mode</b>	<b>Batch Mode</b>
Header	A report title on the first page only. The report title is “Application Report for <applicant name>.”	Every page includes a two-line header.  The first line comes from the text catalog entry HRAM_APPPRINT_PT03. As delivered, the text on the first line is <i>Confidential Report</i> , but you can modify or clear this text in the text catalog entry.  The second line shows the job opening ID and posting title (or text indicating that the application is not associated with a job opening).
General Information	Includes a field that shows the job opening ID.	Does not include the job opening ID, which appears in the page header instead.
Footer	Includes the date, a page number and the title “Application Details for <applicant name>.”	Includes a time stamp in addition to the information shown in single application mode.

Note that this report is associated with a single job opening (or no job opening). Even though an application can be associated with multiple job openings, this report considers only the job opening context from which you generated the report.

## Including Attachments in the Application Details Report

To include attachments of various types in the Application Details report PDF, you must:

- Use PeopleTools 8.55 or later

- Configure the system as described in the *PeopleTools: BI Publisher for PeopleSoft* documentation in the topic “Including External Attachments with BI Publisher Reports.”

The PeopleTools documentation describes how to properly set up the configuration file `pspdfexport.cfg`. This configuration file controls PDF conversion options such as fonts, and it should point to a directory that contains the required fonts. Note that Windows servers generally come preinstalled with all fonts. However, UNIX servers typically do not have preinstalled fonts, and you need to install them manually.

The PeopleTools documentation also describes the global property `psxp_pdfconversion_timeout`, which sets a time out limit for the PDF conversion process. If the conversion process is not finished within the specified time, the process will stop, the user sees a generic error, and details are recorded in log file. If you expect large attachments or a large number of files to be included in the Application Details report, consider setting the time out value high enough to prevent unwanted time outs.

Attachments cannot be included in the Application Details report if:

- The attachment is password protected.
- The attachment file type is `.zip` or `.rar`.

## Application Report Options Page

Use the Application Report Options page (`HRS_PRNT_APPLN`) to choose printing parameters then print application details for a single application.

Navigation:

Click the Print icon on any of these pages:

- Search Applicants (all searches except for Quick Search)
- Manage Applicant
- Search Applications
- Manage Application (has a Print button on the Toolbar)
- Manage Job Opening
- Browse Applicants
- My Applicants pagelet on the Recruiting Home page

This example illustrates the Application Report Options page.

**Application Report Options**

Applicant Name Verity Banister  
 Applicant ID 500329  
 Disposition 070 Offer

Job Posting Title Finance Director - CIT Group  
 Job Opening ID 505007

**Application Detail**

Select	Application Detail	Content Available
<input checked="" type="checkbox"/>	Preferences	✔
<input checked="" type="checkbox"/>	Referral Sources	
<input checked="" type="checkbox"/>	Work Experience	
<input checked="" type="checkbox"/>	Work Experience With Details	
<input checked="" type="checkbox"/>	Education Level	✔
<input checked="" type="checkbox"/>	Training	
<input checked="" type="checkbox"/>	Areas of Study	
<input checked="" type="checkbox"/>	Competencies	
<input checked="" type="checkbox"/>	Degrees	
<input checked="" type="checkbox"/>	School Education	
<input checked="" type="checkbox"/>	Educ and Govt Special Projects	
<input checked="" type="checkbox"/>	Elements	
<input checked="" type="checkbox"/>	Geographic Preferences	
<input checked="" type="checkbox"/>	Honors and Awards	
<input checked="" type="checkbox"/>	International Preferences	
<input checked="" type="checkbox"/>	Licenses and Certifications	
<input checked="" type="checkbox"/>	Language Skills	
<input checked="" type="checkbox"/>	Location	
<input checked="" type="checkbox"/>	Location Preferences	
<input checked="" type="checkbox"/>	Memberships	
<input checked="" type="checkbox"/>	Responsibilities	
<input checked="" type="checkbox"/>	Special Projects	
<input checked="" type="checkbox"/>	Travel Preferences	
<input checked="" type="checkbox"/>	Tests or Examinations	
<input checked="" type="checkbox"/>	References	
<input checked="" type="checkbox"/>	Resume Text	

[Select All](#)      [Deselect All](#)

**Questionnaire Type**

Select	Questionnaire Type	Content Available
<input checked="" type="checkbox"/>	Basic	
<input checked="" type="checkbox"/>	Min Quals	
<input checked="" type="checkbox"/>	Ranking	
<input checked="" type="checkbox"/>	Basic Screening	
<input checked="" type="checkbox"/>	Basic Eligibility	
<input checked="" type="checkbox"/>	Minimum Qualifications	
<input checked="" type="checkbox"/>	Quality Ranking	
<input checked="" type="checkbox"/>	Preliminary	
<input checked="" type="checkbox"/>	Final	
<input checked="" type="checkbox"/>	Pre Screening	
<input checked="" type="checkbox"/>	Online Screening	
<input checked="" type="checkbox"/>	Additional Questions	

[Select All](#)      [Deselect All](#)

**Attachment Type**

Select	Attachment Type	Content Available	Print Latest Document
<input checked="" type="checkbox"/>	Resume		☐
<input checked="" type="checkbox"/>	References		☐
<input checked="" type="checkbox"/>	Transcripts		☐
<input checked="" type="checkbox"/>	Cover Letters		☐
<input checked="" type="checkbox"/>	Personal References		☐
<input checked="" type="checkbox"/>	Professional References		☐
<input checked="" type="checkbox"/>	OIF		☐

[Select All](#)      [Deselect All](#)  
 Exclude Separator Pages

Exclude sections with no content available  
 Save My Selections

[Generate Report](#)

[Return to Previous Page](#)

## Header

The fields at the top of the page identify the applicant and, if relevant, the job opening for the application that is being printed.

When you access this page from the Browse Applicant page, the job opening is the most recent one that the applicant applied for.

When you access this page from the Keyword Search or the Advanced Search on the Search Applicants page, the system does not identify the job opening that the applicant originally applied for.

Copyright © 1988, 2024, Oracle and/or its affiliates.

1037

## Grids for Selecting Report Content

**Note:** The printed report always includes general information about the applicant and the job opening, including the applicant's contact information. The report options page does not list those fields because they are not optional.

<b>Field or Control</b>	<b>Description</b>
<b>Application Detail</b>	<p>This grid lists the main types of application data that can be printed. The list includes all sections that are available on the Application Details page, not just the sections that are in the resume template for the job opening.</p> <p>Options include:</p> <ul style="list-style-type: none"> <li>• General-purpose recruiting information: Preferences, Referral Sources, Work Experience, Education level, Training, References, and Resume Text. Resume text does not include attached resume files, which are listed in the Attachment Type grid on this page.</li> </ul> <hr/> <p><b>Note:</b> Work Experience is an abbreviated form of the application information. Select <i>Work Experience With Details</i> to include the work address and work description details in the application report.</p> <hr/> <ul style="list-style-type: none"> <li>• U.S. Federal sections, which appear only in federal implementations: Federal Preferences and Priority Placement.</li> <li>• The profile content types that appear on the <a href="#">Content Section Configuration – &lt;Content Type&gt; Page</a>.</li> </ul>
<b>Questionnaire Type</b>	<p>This grid lists the lists all the different screening levels that your organization uses, regardless of whether they're used for this particular job. When you include a screening level, the printed report includes all questions that are used for that screening level.</p> <p>The last row in this grid is for <i>Additional Questions</i>. These are questions that are included in the job application that are not used for screening.</p> <p>If an application without a job opening includes prescreening questions from the site's default resume template, selecting any prescreening screening level causes the prescreening questions to be included in the report.</p>

<i>Field or Control</i>	<i>Description</i>
<b>Attachment Type</b>	<p><b>Note:</b> This grid is visible only if you use PeopleTools 8.55 or higher. With earlier versions of PeopleTools, you cannot print attachments as part of the Application Details report.</p> <p>This grid lists all available attachment types in the system. Selected attachment types are appended to the report PDF.</p>

### Page Elements for All Grids

<i>Field or Control</i>	<i>Description</i>
<b>Select</b>	<p>Select this check box to include the specified content in the printed applications.</p> <p>Below each grid, <b>Select All</b> and <b>Deselect All</b> links enable you to quickly select or deselect all items in the grid.</p>
<b>Content Available</b>	<p>A check mark in the <b>Content Available</b> column indicates that the current application includes the specified type of information.</p> <p>In screen reader mode, this column displays the word <i>Yes</i> instead of a check mark.</p>

### Page Elements for the Attachment Type Grid

This grid is visible only if you use PeopleTools 8.55 or higher. With earlier versions of PeopleTools, you cannot print attachments as part of the Application Details report.

<i>Field or Control</i>	<i>Description</i>
<b>Print Latest Document</b>	<p>If an application includes more than one attachment of a given type, the printed application includes all of the attachments unless you select the <b>Print Latest Document</b> check box. Selecting this check box restricts printing to the most recently uploaded file.</p> <p>This check box is selected and disabled for <b>Resume</b> attachments because an application cannot have more than one resume attachment.</p>

<i>Field or Control</i>	<i>Description</i>
<b>Exclude Separator Pages</b>	<p>Attachments are printed as-is, without any contextual information about the application. By default, this contextual information appears on separator pages that are inserted before each attachment. However, you can select the <b>Exclude Separator Pages</b> check box to suppress these extra pages.</p> <p>There is an option on the <a href="#">Recruiting Installation – Applicants Page</a> to suppress separator pages entirely. When this system-level option is selected, the <b>Exclude Separator Pages</b> check box is not shown to end users.</p>

## Additional Page Elements

<i>Field or Control</i>	<i>Description</i>
<b>Exclude sections with no content available</b>	<p>Select this check box to suppress empty sections from the printed output. If this check box is not selected, the report prints headers and an explanatory message for all of the empty sections.</p> <p>Use this check box in conjunction with the <b>Select All</b> links to efficiently exclude empty sections without having to manually select the individual sections with data.</p>
<b>Save My Selections</b>	<p>Select this check box to save your current settings as the default settings for this page.</p> <p>This page does not have a Save button, so the settings are saved when you click the <b>Generate Report</b> button.</p>
<b>Generate Report</b>	<p>Click to generate a PDF file that includes all of the specified information. The report opens in a new browser tab or window, and you can print it using your browser's print command.</p>

## Print Applications Page

Use the Print Applications page (HRS\_RUN\_BTCH\_APPL) to choose printing parameters then run the Application Details (HRS\_BTCH\_APL) application engine process. This batch process prints application details for a group of selected applications.

Navigation:

Select **Group Actions** > **Recruiting Actions** > **Print Applications** on any of these pages:

- Manage Applicant



- Search Applications
- Manage Job Opening

This example illustrates the Print Applications page.

**Print Applications**

Run Control ID RUN\_HRS\_BIP\_2023063000122    Process Monitor    Report Monitor   

Application Detail		Questionnaire Type	
Select	Application Detail	Select	Questionnaire Type
<input checked="" type="checkbox"/>	Preferences	<input checked="" type="checkbox"/>	Basic
<input checked="" type="checkbox"/>	Referral Sources	<input checked="" type="checkbox"/>	Min Quals
<input checked="" type="checkbox"/>	Work Experience	<input checked="" type="checkbox"/>	Ranking
<input checked="" type="checkbox"/>	Work Experience With Details	<input checked="" type="checkbox"/>	Basic Screening
<input checked="" type="checkbox"/>	Education Level	<input checked="" type="checkbox"/>	Basic Eligibility
<input checked="" type="checkbox"/>	Training	<input checked="" type="checkbox"/>	Minimum Qualifications
<input checked="" type="checkbox"/>	Areas of Study	<input checked="" type="checkbox"/>	Quality Ranking
<input checked="" type="checkbox"/>	Competencies	<input checked="" type="checkbox"/>	Preliminary
<input checked="" type="checkbox"/>	Degrees	<input checked="" type="checkbox"/>	Final
<input checked="" type="checkbox"/>	School Education	<input checked="" type="checkbox"/>	Pre Screening
<input checked="" type="checkbox"/>	Educ and Govt Special Projects	<input checked="" type="checkbox"/>	Online Screening
<input checked="" type="checkbox"/>	Elements	<input checked="" type="checkbox"/>	Additional Questions
<input checked="" type="checkbox"/>	Geographic Preferences		
<input checked="" type="checkbox"/>	Honors and Awards		
<input checked="" type="checkbox"/>	International Preferences		
<input checked="" type="checkbox"/>	Licenses and Certifications		
<input checked="" type="checkbox"/>	Language Skills		
<input checked="" type="checkbox"/>	Location		
<input checked="" type="checkbox"/>	Location Preferences		
<input checked="" type="checkbox"/>	Memberships		
<input checked="" type="checkbox"/>	Responsibilities		
<input checked="" type="checkbox"/>	Special Projects		
<input checked="" type="checkbox"/>	Travel Preferences		
<input checked="" type="checkbox"/>	Tests or Examinations		
<input checked="" type="checkbox"/>	References		
<input checked="" type="checkbox"/>	Resume Text		

Attachment Type		
Select	Attachment Type	Print Latest Document
<input checked="" type="checkbox"/>	Resume	<input type="checkbox"/>
<input checked="" type="checkbox"/>	References	<input type="checkbox"/>
<input checked="" type="checkbox"/>	Transcripts	<input type="checkbox"/>
<input checked="" type="checkbox"/>	Cover Letters	<input type="checkbox"/>
<input checked="" type="checkbox"/>	Personal References	<input type="checkbox"/>
<input checked="" type="checkbox"/>	Professional References	<input type="checkbox"/>
<input checked="" type="checkbox"/>	OIF	<input type="checkbox"/>

Exclude Separator Pages

Exclude sections with no content available  
 Generate one PDF report per application

[Return to Previous Page](#)

This page is identical to the Application Report Options Page, except for some differences so that it can support batch printing of applications. This documentation describes only those differences.

## Additional Page Element for Batch Printing

<i>Field or Control</i>	<i>Description</i>
<b>Run</b>	<p>Click to access the Process Schedule Request page, where you can and run the Application Details (HRS_BTCH_APL) application engine process to print the selected applications.</p> <p>Clicking this button saves the batch printing settings on this page, regardless of whether you actually run the report. The saved settings become your default settings the next time you access this page, even if you access it for a different group of applicants.</p> <p>Batch print options are saved separately from the printing options for a single application.</p>
<b>Generate one PDF report per application</b>	Select this check box if you want to create separate PDF files for each application. If this check box is blank, the system creates a single PDF file with all included applications.

## Other Differences for Batch Printing

- Because this page is for multiple applications, the page does not display information about individual applications.  
  
Specifically, the page header does not display applicant and job information, and the selection grids do not include **Content Available** columns.
- You run the report using the Run button and other standard run control page elements. There is no Generate Report button to create the report instantly.
- There is no **Save My Selections** check box; clicking the **Run** button always saves your selections.

---

## Sending Correspondence and Recruitment Letters

This topic provides overviews of the Send Correspondence action and of context-specific recruitment letters. It then discusses how to send correspondence.

## Pages Used to Send Correspondence and Recruitment Letters

<i>Page Name</i>	<i>Definition Name</i>	<i>Usage</i>
<u>Send Correspondence Page</u>	HRS_SEND_CRSP	Send ad hoc letters and emails to applicants. Letters must be template-based; email can be freeform or template-based.

<b>Page Name</b>	<b>Definition Name</b>	<b>Usage</b>
<u>Send Correspondence Preview Page</u>	HRS_FWRD_APP_PRVW	Preview the content of a freeform email. You must return to the Send Correspondence page before sending the email.  The default template that the system uses for freeform email adds text before and after the message that you create; use this page to see your message with the template text applied.
<u>Find Email Address Page</u>	HRS_FND_EMAIL_ADDR	Search for and select employees to whom you want to forward applicants.
<u>Generate Recruitment Letters Page</u>	HRS_RUN_LETTERS	Run the process that generates letters from the recruiting letter queue.

## Understanding the Send Correspondence Action

This overview describes the Send Correspondence action, which you use to produce ad hoc email and letters for applicants.

### Send Correspondence

Use the Send Correspondence action to send the following types of correspondence:

- An email with message text that you manually enter.
- An email with message text that the system generates based on a template that you select.
- A letter that the system generates based on a template that you select.

Recruiting Solutions uses Oracle Business Intelligence Publisher (BI Publisher) to generate recruitment letters.

The Send Correspondence action is available from these pages:

- Search Applicants (all types of searches)
- Manage Applicant
- Search Applications
- Manage Application
- Manage Job Opening
- Manage Applicant List

## Email Generation

When you invoke the Send Correspondence action, the Send Correspondence page appears with *Email* as the default contact method. You can enter freeform message text, or you can select from a list of available templates. If you select a template, the system creates the message text, merging applicant data into the template as necessary. You can preview the system-generated message, but you cannot modify it.

Both template-based and freeform email messages require you to enter the email subject. You can optionally add attachments to the email as well.

---

**Note:** To support freeform text messages, the system applies the delivered HRS\_SEND\_CRSP\_GEN\_EM template when no other template is selected. This is a PeopleTools Workflow generic template, not a BI Publisher template. As delivered, this template places a greeting before your message text and a sign-off after your message text. To remove this wrapper, you can modify the template.

---

## Letter Generation

If you change the contact method to *Letter*, you must select a letter template. Once you select a template, the **Generate** button appears. Clicking this button generates a merged letter and opens it in a new browser window so that you can print and send it. You can optionally preview the merged letter before generating it.

When you generate a letter, it is up to you to print and send it. Letters that you generate using Send Correspondence are *not* added to the queue of letters for the HRS Letter Generation process (HRSLETTR).

## Applicant Notes Created by Send Correspondence

When you send email or generate a letter using the Send Correspondence action, the system records the transaction in an applicant note. You can view the note on the [Manage Applicant Page: Notes Tab](#).

The note is designated as public or private based on the setting you choose when you create the correspondence. The original sender is the only one who can view private notes. Users with standard security can see all public notes. For users with enhanced applicant security, note visibility depends on the public/private setting and on whether the user has access to any of the job openings (if any) that are associated with the transaction.

See [Understanding Enhanced Applicant Security](#).

For email correspondence, the email subject becomes the note subject. When you click the subject to view the note details, the correspondence appears on the Send Correspondence page. You can modify the correspondence (though you cannot change the contact method) and then resend the correspondence. For template-based email, you can change the subject, the attachments, and the Cc and Bcc recipients, but you cannot change the template selection, nor can you modify the message.

For letter correspondence, the default note subject is *Application Letter*. When you click the subject to view the note details, the Applicant Notes page appears, and the letter appears as an attachment to the note. You can edit the note as necessary, including replacing the attachment if you modified the generated letter before printing and sending it.

---

**Note:** If you do not end up sending the physical letter than you generate, you should manually delete the applicant note for that letter. If you modify the letter before sending it, you should update the applicant note accordingly.

---

## Template Selection

The Send Correspondence action uses BI Publisher for PeopleSoft templates for both email and letter correspondence. The templates that are available for selection are those with the HRS\_APP\_LETTERS report definition.

---

**Note:** You cannot use the Send Correspondence action to send offer letters or interview letters, which require the context of their specific pages.

---

See *PeopleTools: BI Publisher for PeopleSoft*

## Batch Processing for Correspondence

The Send Correspondence action processes correspondence in real-time as long as the number of letters or emails does not exceed the Batch Action Threshold specified on the [Recruiting Installation – Applicants Page](#). When the amount of correspondence exceeds the threshold, the Group Action Notification (HRS\_ACT\_MAIL) Application Engine process sends the correspondence in batch.

If the batch process does not successfully send all of the letters or emails, the user who performed the Send Correspondence action receives a failure notification. The notification, which uses the PeopleTools Workflow HRS\_BATCH\_NOTIFY template, advises the user to contact a system administrator, who can restart the process. Because the process tracks correspondence as it is sent, correspondence that was created before the process failed is not reprocessed when the batch process is re-started.

When sending letters (but not email), the system provides links to the letters so that the user can print and send the letters. Access to the completed letters depends on whether the letters were generated in real-time or in batch:

- If the letters are generated in real-time a new browser window opens for each letter.
- If the letters are generated in batch, the originator receives a single email with links for each letter, and clicking a link opens the letter in a browser window.

If the batch process processed some, but not all, letters, the notification to the originator includes links to the letters that were successfully created along with the notification that some letters were not created.

## Understanding Context-Specific Recruitment Letters

This overview discusses the generation and delivery of context-specific recruitment letters.

### Types of Recruitment Letters

PeopleSoft Talent Acquisition manager enables you to generate context-specific recruitment letters during these recruiting activities:

- Entering or reviewing application information on the [Application Details Page](#).
- Scheduling applicant interviews on the [Interview Schedule Page](#).
- Preparing job offers on the [Prepare Job Offer Page](#).

The pages where you perform these recruiting activities all display a **Letter** field that you use to select a letter template.

## Manual Letter Generation vs the HRS Letter Generation Process

All of the pages that support context-specific recruitment letters include a **Generate Letter** link that you click to manually generate the letter. The system merges applicant data into the selected template and opens the resulting letter in a new browser window.

If you select a letter but do not generate it manually, the system automatically places the letter in a queue to be processed by the HRS Letter Generation (HRSLETTR) Application Engine process.

---

**Important!** The HRS Letter Generation process is not used for letters that you send from the Send Correspondence page. It is used only when users specify a context-specific recruitment letter.

---

When a letter has been placed in the HRS Letter Generation process queue but has not yet been processed, manually generating the letter removes it from the queue. Because manually generating a letter prevents it from being processed by the HRS Letter Generation process, the person who manually generates the letter is responsible for delivering the letter.

When you manually generate a letter, the system automatically creates an applicant note with the letter as an attachment.

The HRS Letter Generation process, on the other hand, creates a single file with all of the letters that were generated using the same template. This means that if multiple letters were based on the same template, individual letter documents do not exist. For this reason, the HRS Letter Generation process does not create an applicant note or associate an attachment with the applicant record.

## Letter Delivery

After generating a letter manually, users have two delivery options: hard copy and email.

For hard copy delivery, users can print the letter from the browser window where the letter is displayed. Users can also save the letter locally for later printing. The default file format for the generated letter is .rtf (rich text file), which is compatible with most word processing applications.

For email delivery, an **Email Applicant** link enables users to access the Send Correspondence page with the generated letter already attached. Users can enter their own email message text before sending. If there is no email address for the applicant, the system displays a warning.

---

**Note:** Only interview and job offer letters can be emailed. The Application Details page does not have the Email Applicant option.

---

Clicking the **Email Applicant** link before generating the letter displays the Send Correspondence page without any attachments. Although you can select letter templates from the Send Correspondence page, the available templates are not context-sensitive: choices are always the same as those on the Application Details page, even if you access the Send Correspondence page from the Interview Schedule page or the Prepare Job Offer page.

## Modified Letters and the Upload Option

To modify a template-based letter, you must generate it, save it locally, and make your changes to the local copy. To ensure accurate records, you must then upload the modified document to the system.

For interview letters and offer letters, the system provides an **Upload Letter** link that you can click to upload the modified document to the correct context. If you subsequently click the **Email Applicant** link, the system automatically attaches the modified letter (rather than the original) to the email.

## Applicant Notes Created by Context-Specific Recruitment Letters

Applicant notes, which appear on the [Manage Applicant Page: Notes Tab](#), are automatically created for recruitment letters that you generate individually (The HRS Letter Generation process does not create applicant notes for letters that it produces in batch.) By default, the automatically-generated applicant notes are designated as public, but you can make a note private so that only the sender can see it.

The system generates applicant notes when:

- You generate a recruitment letter.

If you generate a letter but do not send it, you should manually delete the note from the applicant's record.

- You upload a recruitment letter.

The Application Details page does not have an upload link. If you modify an application letter, you should manually replace the attachment in the related note.

- You email a recruitment letter.

If you perform multiple letter-related actions, the applicant ends up with multiple notes that refer to the same interaction. For example, if you generate a letter, then upload a modified letter, then email the modified letter, the system creates three separate applicant notes related to this one letter. To eliminate redundant applicant notes, delete these extra notes manually on the Manage Applicant page: Notes tab.

When you email a letter to the applicant, the email subject becomes the note subject. When you generate or upload a letter, the default subject text describes the letter context: *Application Letter*, *Interview Letter*, or *Offer Letter*.

Clicking the subject of an applicant note opens a page that displays the note details; the actual letter appears as an attachment to the note. You can edit the note as necessary. If the note is for an email, the note details appear in the Send Notification page, where you can modify the email and then resend it.

## Letter Selection

Recruitment letters use BI Publisher for PeopleSoft templates. The templates that are available for selection are those with the following report definitions:

- Templates from the HRS\_APP\_LET report definition are available from the Application Details page.
- Templates from the HRS\_INT\_LET report definition are available from the Interview Schedule page.
- Templates from the HRS\_OFF\_LET report definition are available from the Prepare Job Offer page.

## Delivered Letter Templates

Talent Acquisition manager delivers the following recruitment letter templates:

<i>Report Definition</i>	<i>Template ID</i>	<i>Template File</i>	<i>Purpose</i>
HRS_APP_LET	HRS_APP_LETTER_ACQ	LTRACQxml.rtf	Acknowledges receipt of applicant's resume.

<b>Report Definition</b>	<b>Template ID</b>	<b>Template File</b>	<b>Purpose</b>
HRS_APP_LET	HRS_APP_LETTER_ANO	Ltranoxml.rtf	Notifies applicant of no current job openings.
HRS_APP_LET	HRS_APP_LETTER_CR1	LTRCR1xml.rtf	Thanks applicant for interest in company and states that the applicant's qualifications are being reviewed.
HRS_APP_LET	HRS_APP_LETTER_IR	LTRIR.rtf	Interview rejection letter.
HRS_APP_LET	HRS_APP_LETTER_LAQ	Ltrlaqxml.rtf	Thanks applicant for interest in company and states that the applicant's qualifications are being reviewed.
HRS_INT_LET	HRS_INT_LETTER_IS1	LTRIS1xml.rtf	Notifies applicant of scheduled interview date and time.
HRS_INT_LET	HRS_INT_LETTER_IS2	LTRIS2xml.rtf	Notifies applicant of scheduled interview date and time.
HRS_INT_LET	HRS_INT_LETTER_IS3	LTRIS3xml.rtf	Notifies applicant of scheduled interview date and time.
HRS_OFF_LET	HRS_OFF_LETTER_OF1	LTROF1xml.rtf	Notifies applicant of offer and compensation package.
HRS_OFF_LET	HRS_OFF_LETTER_OF2	LTROF2xml.rtf	Notifies applicant of a revised offer and compensation package.

### **Related Links**

[Entering Application Details](#)

[Scheduling and Managing Interviews](#)

[Creating Job Offers](#)

## **Send Correspondence Page**

Use the Send Correspondence page (HRS\_SEND\_CRSP) to send ad hoc letters and emails to applicants.



Letters must be template-based; email can be freeform or template-based.

Navigation:

Select Send Correspondence (or **Applicant Actions** > **Send Correspondence**) from the row-specific action menu or the group action menu on any of these pages:

- Search Applicants (all types of searches)
- Manage Applicant
- Search Applications
- Manage Application
- Manage Job Opening
- Manage Applicant List

This is the first of two example illustrating the Send Correspondence page. In this example, enhanced applicant security is active, so the page displays instructional text that would not be there if all users had standard security.

## Send Correspondence

The access setting affects who can see the applicant note that correspondence creates.  
 Private correspondence can only be seen by the author.  
 Public correspondence that is not associated with any job openings is visible to all users.  
 Public correspondence that is associated with job openings is visible to the job openings' hiring teams and creators. It is also visible to administrators and any other users who have unrestricted access to all applicant data.

**Recipients** Personalize | Find | View All |  First ◀ **1 of 1** ▶ Last

ID	Applicant Name
12	Rosanne Stocker

**Job Openings** Personalize | View All |  First ◀ **1 of 1** ▶ Last

Job Opening ID	Posting Title		
<input style="width: 90%;" type="text"/>			

[Add Job Opening](#)

**Message Type and Method**

\*Contact Method Email

Letter

**Recipient Information**

To

Cc  [Find](#)

Bcc  [Find](#)

Include Interested Parties

**Sender Information**

From Betty Locherty

This is the second of two examples illustrating the Send Correspondence page.

**Message**

\*Subject

\*Access Public ▼

\*Message

---

**Attachments**

No attachments have been added to this Correspondence

[Add Attachment](#)

---

[Preview](#)    [Send](#)    [Cancel](#)

This example illustrates the Recipients grid when the Job Opening column is visible. When the Job Opening column is visible, the separate Job Openings grid is hidden.

<b>Recipients</b>		
ID	Applicant Name	Job Opening
500275	Javier Kroh	305089 - Executive Services Administrator

### Understanding Job Openings in the Send Correspondence Transaction

This page displays job opening information in one of two ways:

- If the transaction was initiated from a specific application, the job opening is identified in the **Recipients** grid, and the user cannot modify the information.  
  
This occurs when the transaction is initiated from the Manage Application page or from the list of applications on the Manage Applicant page, the Search Applications page, or the Manage Job Opening page
- If the transaction was initiated from the applicant record (without the context of a specific application), a separate **Job Openings** grid appears, and the user can manually add job openings to the grid.

This occurs when the transaction is initiated from the Search Applicant page or the Manage Applicant List page.

## Instructional Text

If enhanced applicant security is enabled for at least one recruiting role type, instructional text at the top of the page explains how the combination of the transaction's job openings and its public/private setting affects which users can see the note.

See [Understanding Enhanced Applicant Security](#)

## Recipients

<i>Field or Control</i>	<i>Description</i>
<b>ID and Applicant Name</b>	These fields identify the applicants to whom you are sending correspondence.
<b>Job Opening</b>	<p>If you initiated the transaction from the context of a job opening, this field identifies that job opening.</p> <p>If this column is visible in the <b>Recipients</b> grid, the page does not display a separate <b>Job Openings</b> grid.</p>

## Job Openings

The **Job Openings** grid and the associated **Add Job Opening** button are visible only if you initiated the transaction without the context of a job opening. Use this grid to manually associate job openings with the transaction.

<b>Field or Control</b>	<b>Description</b>
<b>Job ID and Posting Title</b>	<p>Select one or more job openings to associate with this transaction. You can only select job openings to which you have access, and they must be in <i>Open</i>, <i>Filled/Closed</i>, or <i>Hold</i> status.</p> <p>All users have access to job openings that they created and where they are on the hiring team. Users with standard applicant security can additionally access job openings if they the department security tree gives the user access to the job opening's department. Users with enhanced applicant security do not gain access to job openings through the department security tree.</p> <p>See <a href="#">Understanding Enhanced Applicant Security</a>.</p> <p>Associating the transaction with job openings can affect the visibility of the applicant note that the transaction creates. Specifically, users with enhanced applicant security can view the note only if they have access to at least one of the job openings.</p> <p>Job openings do not affect note visibility for users with standard security.</p>
<b>Add Job Opening</b>	Click this button to add additional rows to the <b>Job Openings</b> grid.

### Message Type and Method

<b>Field or Control</b>	<b>Description</b>
<b>Contact Method</b>	<p>Select <i>Email</i> or <i>Letter</i>.</p> <p>The default value is <i>Email</i>. In this mode, the page shows standard email fields.</p> <p>If you select <i>Letter</i>:</p> <ul style="list-style-type: none"> <li>• In the <b>Recipient Information</b> section, the <b>Cc</b> and <b>Bcc</b> fields are hidden.</li> <li>• In the <b>Message</b> section, the <b>Subject</b> and <b>Message</b> fields are hidden, and a <b>Notes</b> field appears instead.</li> <li>• The <b>Sender Information</b> and <b>Attachments</b> sections are hidden entirely.</li> </ul>

<b>Field or Control</b>	<b>Description</b>
<b>Letter</b>	Select a letter template to use. This field is optional when you send email and required when you send a letter.

## Recipient Information

<b>Field or Control</b>	<b>Description</b>
<b>To</b>	<p>This field appears for both email and letter correspondence. It displays the names of the applicants to whom you are sending correspondence and is not editable.</p> <p>If you are sending the correspondence to multiple applicants, all names appear together. However, the system sends separate correspondence to each applicant: template-based messages are generated separately for each recipient, and the applicants do not see each other's names in the To field of the email they receive.</p>
<b>Cc, Bcc, and Find</b>	<p>These fields appear only for email correspondence.</p> <p>By default, the sender's preferred email address appears in the Cc field, and the Bcc field is empty. You can edit these fields directly to add or remove recipients, or you can look up recipients who are employees by clicking the <b>Find</b> link to access the Find Email Address page.</p> <p>See <a href="#">Find Email Address Page</a>.</p>
<b>Include Interested Parties</b>	<p>Select this check box if you want the people listed as interested parties for the applicant to receive a copy of this email.</p> <p>An applicant's interested parties are listed on the Manage Applicant page: Interested Parties tab.</p> <p>The system sends the interested parties copies of the correspondence, but does not display their names or email addressed on this page.</p>

## Sender Information

If the Contact Method is *Letter*, this section is hidden.

<b>Field or Control</b>	<b>Description</b>
<b>From</b>	<p>If the Contact Method is <i>Email</i>, this field displays the sender's name.</p> <p>When the system creates an applicant note for this transaction, the sender is considered the note author.</p>

## Message

<b>Field or Control</b>	<b>Description</b>
<b>Subject</b>	<p>This field appears only for email correspondence.</p> <p>Enter the email subject. This field is required for email correspondence (whether freeform or template-based).</p>
<b>Access</b>	<p>This field appears for both email and letter correspondence. Select a value to indicate whether the note that the transaction creates is public or private.</p> <p>Select <i>Private</i> to limit access to the note's author (the person forwarding the applicant)..</p> <p>Select <i>Public</i> to allow other users to see the note.</p> <p>Users with standard security can see all public notes.</p> <p>Users with enhanced applicant security can see public notes as long as they have access to one of the associated job openings (or if there are no associated job openings).</p>
<b>Message</b>	<p>This field appears only for email correspondence.</p> <p>For freeform email, enter the text of the email message.</p> <p>If you select a template, this field disappears until you click the Preview button, at which point the field displays the non-editable template-based message text.</p> <hr/> <p><b>Note:</b> To support freeform text messages, the system applies the delivered HRS_SEND_CRSP_GEN_EM template when no other template is selected. This is a PeopleTools Workflow generic template, not a BI Publisher template. As delivered, this template places a salutation before your message text and a signature after your message text. If your organization is using the delivered template, your message should not duplicate the greeting or sign-off text from the template.</p> <hr/>

<b>Field or Control</b>	<b>Description</b>
<b>Notes</b>	<p>This field appears only for letter correspondence.</p> <p>Enter any comments that should be saved in the applicant note that the system creates when it generates the letter.</p>

## Attachments

If the Contact Method is *Email*, use this section to add attachments to and remove attachments from the email.

If the Contact Method is *Letter*, this entire section is hidden.

## Action Buttons

<b>Field or Control</b>	<b>Description</b>
<b>Preview</b>	<p>Click to preview the email or letter.</p> <p>When you preview a letter or a template-based email, the message text appears directly on the Send Correspondence page. If you are not satisfied with what you see, select a different letter (or clear the Letter field) to make changes.</p> <p>When you preview a freeform email, the message text appears on the Send Correspondence Preview page. You can return to the Send Correspondence page without sending.</p>



<b>Field or Control</b>	<b>Description</b>
<p><b>Send</b></p>	<p>Click to send email correspondence, create the associated applicant note, and return to the page from which you invoked the Send Correspondence action. This button appears only when the Contact Method is <i>Email</i>.</p> <p>If enhanced applicant security is active for at least one recruiting role type, and the access is <i>Public</i>, and the transaction is not associated with any job openings, then saving triggers a warning message that the note will be visible to all users. This gives the sender an opportunity to protect job-opening related information by editing the message or associating the note to the relevant job opening(s).</p> <p>If the number of email notifications does not exceed the threshold established on the <u>Recruiting Installation – Applicants Page</u>, the notifications are sent immediately, before the Send Correspondence page closes.</p> <p>If the number of email notifications does exceed the threshold, the notifications are sent by the Group Action Notification (HRS_ACT_MAIL) Application Engine process. The originator receives a notification only if the batch process fails.</p>
<p><b>Generate</b></p>	<p>Click to generate letter correspondence, create the associated applicant note, and return to the page from which you invoked the Send Correspondence action. This button appears only when the Contact Method is <i>Letter</i>.</p> <p>The system creates the associated applicant note immediately. If you don't print and send the letter, be sure to delete the note.</p> <p>If the number of letters does not exceed the threshold established on the <u>Recruiting Installation – Applicants Page</u>, the system generates the letter or letters immediately and opens a new browser window for each letter.</p> <p>If the number of letters does exceed the threshold, the letters are generated by the Group Action Notification (HRS_ACT_MAIL) Application Engine process. When the batch process is finished, the system sends the originator an email with links to each letter. If the process fails, the notification includes links to the letters that were generated before the failure and advises the originator to contact an administrator who can restart the process for the remaining letters.</p>

<b>Field or Control</b>	<b>Description</b>
<b>Resend</b>	This button appears only if you access the page from the Manage Applicant page: Notes tab. Click to resend email correspondence if there were delivery issues or if you have modified the email. You can always modify the subject, the attachments, and the Cc and Bcc recipients before resending, but you can modify the message text only for freeform correspondence.
<b>Cancel</b>	Click this button to return to the previous page without sending the correspondence.

## Send Correspondence Preview Page

Use the Send Correspondence Preview page (HRS\_FWRD\_APP\_PRVW) to preview the content of a freeform email.

You must return to the Send Correspondence page before sending the email.

Navigation:

Click the **Preview** button on the Send Correspondence page when it is configured to send a freeform email.

This example illustrates the Send Correspondence Preview page.

**Send Correspondence Preview**

**To** Ganguly Sarbani,Rupinder Arora

**Cc** HCMGENUser1@ap6023fems.us.oracle.com

**Bcc**

**From**

**Subject**

**Message**

Dear Ganguly Sarbani

We are still awaiting a writing sample from you. Please supply this sample as soon as possible.

Thanks,  
Betty Locherty

<b>Field or Control</b>	<b>Description</b>
<b>To</b>	The preview page lists all of the recipients, even though each recipient will receive a separate email that does not list other recipients.
<b>Message</b>	Displays the message to be sent to the first applicant. Note that a salutation and a signature are added to the texts provided on the Send Correspondence page.

## Find Email Address Page

Use the Find Email Address page (HRS\_FND\_EMAIL\_ADDR) to search for and select employees to whom you want to forward applicants.

Navigation:

Click the **Find** link on the Send Correspondence page.

This example illustrates the Find Email Address page.

**Find Email Address**

**Find Employees**

Employee ID

Name

Search Results					Personalize   View All
	Empl ID	Name	Email Type	Email Address	Preferred
<input type="checkbox"/>	ADCRM1002	Melissa Richards	Home	HCMGENUser1@ap6023fems.us.oracle.com	Y
<input type="checkbox"/>	KUD004	Melissa Rosenberg	Home	HCMGENUser1@ap6023fems.us.oracle.com	Y

### Find Employees

Enter a full or partial employee ID or name and click **Search** to display the search results.

### Search Results

This group box displays the search results. Select one, several, or all employees in the search results and click the **Add Selected** button to add their email addresses to the appropriate fields on the page from which you initiated the email address lookup.

<b>Field or Control</b>	<b>Description</b>
<b>Preferred</b>	Indicates whether this is the preferred email address for the employee. If an employee has multiple email addresses, the system lists all email addresses and indicates which email address is the preferred email address so that you can select the email address that is most appropriate.

## Generate Recruitment Letters Page

Use the Generate Recruitment Letters page (HRS\_RUN\_LETTERS) to run the process that generates letters from the recruiting letter queue.

Navigation:

**Recruiting > Administration > Generate Recruitment Letters**

This example illustrates the Generate Recruitment Letters page.

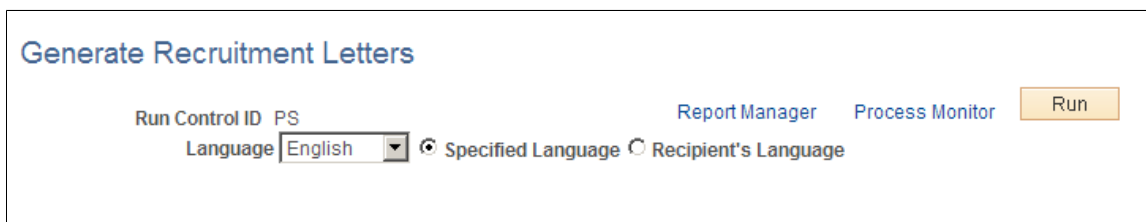

<b>Field or Control</b>	<b>Description</b>
<b>Language</b>	Choose a language and select the <b>Specified</b> option to generate all letters using the language that you explicitly select.  Select the <b>Recipient's</b> option to print each letter in the preferred language of its recipient. In this case, the language that you select in the <b>Language</b> field is used only when there is no record of the recipient's preferred language.
<b>Run</b>	Click to run the HRS Letter Generation job (HRSLETTR) using PeopleSoft Process Scheduler.

**Note:** If you select *Printer* in the **Type** field on the Process Scheduler Request page, you must enter the URL address for your printer in the **Output Destination** field.

## Forwarding Applicants

This topic provides an overview of applicant forwarding and discusses how to forward applicants.

## Pages Used to Forward Applicants

<i>Page Name</i>	<i>Definition Name</i>	<i>Usage</i>
<a href="#">Forward Applicant Page</a>	HRS_FWRD_APPL	Forward applicants.
<a href="#">Forward Applicant Preview Page</a>	HRS_FWRD_APP_PRVW	Preview a message before sending it.

## Understanding Applicant Forwarding

Forwarding an applicant sends applicant information to one or more persons. When users forward an applicant, the system sends a notification (HRS\_FORWARD\_APPLICANT) to the recipients that the recruiter specifies on the Forward Applicant page.

Forwarding an applicant is similar to routing an applicant. However, when you forward an applicant, the system does not change the applicant disposition, nor do recipients have an online process for recording their feedback.

### Attaching Resumes When Forwarding

Your security configuration affects how the Forward Applicant transaction handles applicant resumes.

If at least one recruiting role type is configured to use enhanced applicant security, then users must explicitly choose whether to attach resumes when forwarding. The Include Resume check box becomes visible on the Forward Applicant page.

If you do not use enhanced applicant security for any recruiting role types, then the Forward Applicant transaction automatically attaches a resume (if one exists).

See [Understanding Enhanced Applicant Security](#).

When attaching the applicant's resume, the system uses this logic:

- If the applicant has multiple applications, only the resume from the most recently created application is sent.  
If the most recent application does not have a resume, there is no attachment.
- Attached resume files are delivered in their original file format.
- If the resume text was pasted into the system rather than uploaded as an attachment, the resume text is sent as an HTML file if resume text field is rich text-enabled or as an unformatted text (.txt) file if the resume text field is not rich text-enabled.
- If an application has both online resume text and a file attachment, only the file attachment is sent.

### Applicant Notes for Forwarding

When you forward an applicant, the system records the transaction in an applicant note. The note appears on the [Manage Applicant Page: Notes Tab](#).

See [Understanding Applicant Notes](#) for more details about the note that is created by the Forward Applicant transaction.

## Forward Applicant Page

Use the Forward Applicant page (HRS\_FWRD\_APPL) to forward applicants.

Navigation:

- Click the **Forward Applicant** toolbar button on the Manage Applicant page.
- Click the **Forward Applicant** icon or use the Forward Applicant group action on the Manage Applicant List page.
- Select Forward Applicant (or **Applicant Actions** > **Forward Applicant**) from the row-specific action menu or the group action menu on any of these pages:
  - Search Applicants (all types of searches)
  - Search Applications
  - Manage Application
  - Manage Job Opening

This is the first of two examples illustrating the Forward Applicant page. In this example, enhanced applicant security is active, so the page displays instructional text that would not be there if all users had standard security.

## Forward Applicant

The access setting affects who can see the applicant note that forwarding creates.  
 Private messages can only be seen by the author.  
 Public messages that are not associated with any job openings are visible to all users.  
 Public messages that are associated with job openings are visible to the job openings' hiring teams and creators. They are also visible to administrators and any other users who have unrestricted access to all applicant data.

<b>Forward Applicant</b>		Personalize   View All	First  1-3 of 3  Last
ID	Applicant Name		
12	Rosanne Stocker		
17	Jim Furlong		
18	Theresa Kelsey		

<b>Job Openings</b>		Personalize   View All	First  1 of 1  Last
Job Opening ID	Posting Title		
<input style="width: 90%;" type="text"/>	<input style="width: 90%;" type="text"/>		

Add Job Opening

### Recipient Information

\*To   Find

Cc   Find

Bcc   Find

### Sender Information

**From** Betty Locherty

This is the second of two examples illustrating the Forward Applicant page.

**Message**

\*Subject

\*Access

Include Resume

Message

Applicant Name : Rosanne Stocker  
Applid : 12

You can view Rosanne Stocker's profile from  
[http://slc11kqz.us.oracle.com:8000/psp/h92aygmex/EMPLOYEE/HRMS/c/HRS\\_HRAT.HRS\\_MANAGE\\_APP.GBL?Page=HRS\\_MANAGE\\_APP&Action=U&HRS\\_PERSON\\_ID=12](http://slc11kqz.us.oracle.com:8000/psp/h92aygmex/EMPLOYEE/HRMS/c/HRS_HRAT.HRS_MANAGE_APP.GBL?Page=HRS_MANAGE_APP&Action=U&HRS_PERSON_ID=12) page.

Applicant Name : Jim Furlong  
Applid : 17

This example illustrates the Forward Applicant grid when the Job Opening column is visible. When the Job Opening column is visible, the separate Job Openings grid is hidden.

Forward Applicant			Personalize	View All	First	1-2 of 2	Last
ID	Applicant Name	Job Opening					
300246	Mason Johnson	300291 - Office Assistant-R					
300245	Jacob Smith	300292 - Office Assistant-R					

## Understanding Job Openings in the Forward Applicant Transaction

This page displays job opening information in one of two ways:

- If the transaction was initiated from a specific application, the job opening is identified in the **Forward Applicant** grid, and the user cannot modify the information.

This occurs when the transaction is initiated from the Manage Job Opening page, the Search Applications page, or the Manage Application page.

- If the transaction was initiated from the applicant record (without the context of a specific application), a separate **Job Openings** grid appears, and the user can manually add job openings to the grid.



This occurs when the transaction is initiated from the Search Applicant page, the Manage Applicant page, or the Manage Applicant List page.

### Instructional Text

If enhanced applicant security is enabled for at least one recruiting role type, instructional text at the top of the page explains how the combination of the transaction's job openings and its public/private setting affects which users can see the note.

See [Understanding Enhanced Applicant Security](#)

### Forward Applicant

<i>Field or Control</i>	<i>Description</i>
<b>ID and Applicant Name</b>	These fields identify the applicants that are being forwarded.
<b>Job Opening</b>	<p>This column is visible only if you initiated the transaction from the context of a job opening. It identifies the job opening from which you forwarded the applicant.</p> <p>If this column is visible in the <b>Forward Applicant</b> grid, the page does not display a separate <b>Job Openings</b> grid.</p>

### Job Openings

The **Job Openings** grid and the associated **Add Job Opening** button are visible only if you initiated the transaction without the context of a job opening. Use the grid to manually associate job openings with the transaction.

<b>Field or Control</b>	<b>Description</b>
<b>Job ID and Posting Title</b>	<p>Select one or more job openings to associate with this transaction. You can only select job openings to which you have access, and they must be in <i>Open</i>, <i>Filled/Closed</i>, or <i>Hold</i> status.</p> <p>All users have access to job openings that they created and where they are on the hiring team. Users with standard applicant security can additionally access job openings if they the department security tree gives the user access to the job opening's department. Users with enhanced applicant security do not gain access to job openings through the department security tree.</p> <p>See <a href="#">Understanding Enhanced Applicant Security</a>.</p> <p>Associating the transaction with job openings can affect the visibility of the applicant note that records the transaction. Specifically, users with enhanced applicant security can view the note only if they have access to at least one of the job openings.</p> <p>Job openings do not affect note visibility for users with standard security.</p>
<b>Add Job Opening</b>	Click this button to add additional rows to the <b>Job Openings</b> grid.

## Recipient Information

Use this group box to enter email addresses of the people to whom you want to forward these applicants.

<b>Field or Control</b>	<b>Description</b>
<b>To, Cc, and Bcc</b>	Enter the email addresses of the people to whom you are forwarding the applicant.
<b>Find</b>	<p>Click to access the Find Email Address page, where you can search for and select employees to whom you want to forward these applicants.</p> <p>See <a href="#">Find Email Address Page</a>.</p>

## Sender Information

<b>Field or Control</b>	<b>Description</b>
<b>From</b>	<p>Displays the name of the user who is forwarding the applicant.</p> <p>When the system creates an applicant note for this transaction, the sender is considered the note author.</p>

## Message

<b>Field or Control</b>	<b>Description</b>
<b>Subject</b>	Enter the subject of the email.
<b>Access</b>	<p>Select a value to indicate whether the note that the transaction creates is public or private.</p> <p>Select <i>Private</i> to limit access to the note's author (the person forwarding the applicant)..</p> <p>Select <i>Public</i> to allow other users to see the note.</p> <p>Users with standard security can see all public notes.</p> <p>Users with enhanced applicant security can see public notes as long as they have access to one of the associated job openings (or if there are no associated job openings). However, these users will not be able to see the message details.</p>
<b>Include Resume</b>	<p>Select this check box to attach the applicant's resume to the message.</p> <p>This check box is visible only if at least one recruiting role type is subject to enhanced applicant security. When this check box is visible, it is visible to all users, not just those subject to enhanced applicant security.</p> <p>See <a href="#">Understanding Applicant Forwarding</a>.</p>

<b>Field or Control</b>	<b>Description</b>
<b>Message</b>	<p>Enter the message text.</p> <p>The default message text comes from the HRS_FORWARD_APPLICATION template. The template includes the name, and ID of each included applicant, a link to the Manage Applicant page for each applicant, and a sign-off that includes the sender's name.</p> <p>For users subject to standard applicant security, the Message field is initially blank. The user adds any personalized message, and when the user sends, the system adds the template text to the end of the message. To see the entire message, the user needs to click the <b>Preview</b> button to access the <a href="#">Forward Applicant Preview Page</a>.</p> <p>For users subject to enhanced applicant security, the template text appears in the Message field, so the entire message is visible on this page while the user personalizes the message. Additionally, the system adds <i>&lt;enter your text here&gt;</i> to the beginning of the message. Users can then modify this portion of the message before sending.</p> <p>For more information about standard and enhanced applicant security, see <a href="#">Understanding Enhanced Applicant Security</a>.</p>

## Buttons

<b>Field or Control</b>	<b>Description</b>
<b>Preview</b>	<p>Click to access the <a href="#">Forward Applicant Preview Page</a>, where you can preview the email before you send it.</p> <p>Before you can preview the message, you must enter an email address and a message subject.</p>
<b>Send</b>	<p>Click to send the email. The system creates an applicant note for the transaction.</p> <p>If enhanced applicant security is active for at least one recruiting role type, and the access is <i>Public</i>, and the transaction is not associated with any job openings, then saving triggers a warning message that the note will be visible to all users. This gives the sender an opportunity to protect job-opening related information by editing the message or associating the note to the relevant job opening(s).</p>

<b>Field or Control</b>	<b>Description</b>
<b>Resend</b>	<p>After you forward an applicant, you can re-access the transaction from the <a href="#">Manage Applicant Page: Notes Tab</a>. In this mode, the page displays the <b>Resend</b> button instead of the <b>Send</b> button. You can modify the original message before resending.</p> <p>Resending is considered a separate transaction, and a new applicant note is created when you resent.</p>
<b>Cancel</b>	Click to return to the previous page without sending or saving the email.

## Forward Applicant Preview Page

Use the Forward Applicant Preview page (HRS\_FWRD\_APP\_PRVW) to preview a message before sending it.

Navigation:

Click the **Preview** button on the Forward Applicant page.

This example illustrates the Forward Applicant Preview page.

**Forward Applicant Preview**

\*To

Cc

Bcc

From

Subject

---

**Message**

Take a look at these applicants and let me know what you think.

Applicant Name : Henrietta Bourallee  
 Applid : 500008

You can view Henrietta Bourallee's profile from  
[http://rtdc78252qaemt.us.oracle.com/psp/tm920dvInt/EMPLOYEE/HRMS/c/HRS\\_HRAT.HRS\\_MANAGE\\_APP.GBL?Page=HRS\\_MANAGE\\_APP&Action=U&HRS\\_PERSON\\_ID=500008](http://rtdc78252qaemt.us.oracle.com/psp/tm920dvInt/EMPLOYEE/HRMS/c/HRS_HRAT.HRS_MANAGE_APP.GBL?Page=HRS_MANAGE_APP&Action=U&HRS_PERSON_ID=500008) page.

Applicant Name : CaiLee Calvert  
 Applid : 500002

You can view CaiLee Calvert's profile from  
[http://rtdc78252qaemt.us.oracle.com/psp/tm920dvInt/EMPLOYEE/HRMS/c/HRS\\_HRAT.HRS\\_MANAGE\\_APP.GBL?Page=HRS\\_MANAGE\\_APP&Action=U&HRS\\_PERSON\\_ID=500002](http://rtdc78252qaemt.us.oracle.com/psp/tm920dvInt/EMPLOYEE/HRMS/c/HRS_HRAT.HRS_MANAGE_APP.GBL?Page=HRS_MANAGE_APP&Action=U&HRS_PERSON_ID=500002) page.

Applicant Name : James Cordeira  
 Applid : 500014

You can view James Cordeira's profile from  
[http://rtdc78252qaemt.us.oracle.com/psp/tm920dvInt/EMPLOYEE/HRMS/c/HRS\\_HRAT.HRS\\_MANAGE\\_APP.GBL?Page=HRS\\_MANAGE\\_APP&Action=U&HRS\\_PERSON\\_ID=500014](http://rtdc78252qaemt.us.oracle.com/psp/tm920dvInt/EMPLOYEE/HRMS/c/HRS_HRAT.HRS_MANAGE_APP.GBL?Page=HRS_MANAGE_APP&Action=U&HRS_PERSON_ID=500014) page.

Thank You  
 Betty Locherty

## Changing Applicant Statuses

This topic discusses how to change applicant statuses.

See [Setting Up Recruiting Statuses](#).

### Page Used to Change Applicant Statuses

<i>Page Name</i>	<i>Definition Name</i>	<i>Usage</i>
<a href="#">Change Applicant Status Page</a>	HRS_GACT_RCM_STS	Change an applicant's status.

## Understanding Applicant Statuses

Applicant statuses are the statuses that you define for the Applicant recruitment area, which deals with the overall availability of the applicant.

This differs from the applicant's disposition, which is the applicant's status relative to a particular job opening. The Updating an applicant status can affect the applicant's dispositions based on your configuration for status change effects.

See [Understanding Recruiting Statuses](#).

Changing the applicant status doesn't affect the applicant's Candidate Gateway account (if one exists). To inactivate a Candidate Gateway account after changing an applicant's status, use the **Inactivate Online Account** check box on the [Manage Applicant page: Applicant Data Tab](#).

## Change Applicant Status Page

Use the Change Applicant Status page (HRS\_GACT\_RCM\_STS) to change an applicant's status.

Navigation:

Select Change Applicant Status (or **Applicant Actions** > **Change Applicant Status**) from the row-specific action menu or the group action menu on any of these pages:

- Search Applicants (all types of searches)
- Search Applications
- Manage Application
- Manage Job Opening
- Manage Applicant List

You can also perform this action on the Manage Applicant page by clicking the **Change Status** button on the toolbar.

This example illustrates the Change Applicant Status page.

The screenshot shows a dialog box titled "Change Applicant Status". It features two dropdown menus. The first dropdown, labeled "\* Status Code", is currently set to "030 Inactive". The second dropdown, labeled "Status Reason", is currently empty. At the bottom of the dialog, there are two buttons: "Change Status" and "Cancel".

<b>Field or Control</b>	<b>Description</b>
<b>Status Code</b>	Select the applicant status to assign.  The delivered statuses are <i>010 Active</i> , <i>020 Hired</i> , <i>030 Inactive</i> , and <i>040 Queued</i> . These are the status codes that are defined for the Applicant recruitment area on the <a href="#">Recruiting Status and Reason Page</a>
<b>Status Reason</b>	After selecting a new status, optionally select a reason for assigning the status. The reasons that are available for specific statuses are configured on the Statuses and Reasons page.

## Managing Applicant Lists

This topic provides an overview of applicant lists and describes how to manage applicant lists.

### Pages Used to Manage Applicant Lists

<b>Page Name</b>	<b>Definition Name</b>	<b>Usage</b>
<a href="#">Applicant Lists Page</a>	HRS_APPL_LIST	View existing applicant lists.
<a href="#">Add to Applicant List Page</a>	HRS_SELECT_LIST	Select the applicant list to which you want to add an applicant.
<a href="#">Create New List Page</a>	HRS_CREATE_LIST	Create an applicant list.
<a href="#">Manage Applicant List Page</a>	HRS_LIST_MEMBER	Manage an applicant list and its membership.
<a href="#">Edit Primary List Information Page</a>	HRS_CREATE_LIST	Edit information about the list, including the list name and whether it is private or public.

### Understanding Applicant Lists

Applicant lists are manually-constructed groups of applicants that recruiters can use to facilitate the recruiting process. Recruiters can add applicants to a list and then perform tasks for one, several, or all applicants on the list at the same time.

Lists can be public or private. The creator of an applicant list is the owner of the list. The list owner is the only user with access to private lists. Anyone with access to the applicant list pages has access to public lists.



Anyone with access to a list can view the list, take actions on the applicants, add applicants to the list, and view primary list information (the list name, its active/inactive status, and whether the list is public). However, only the list owner can update the primary list information.

On the Recruiting Home page, the [My Applicant Lists Pagelet](#) displays active applicant lists that are either public lists or that are owned by the current user.

## Applicant Lists Page

Use the Applicant Lists page (HRS\_APPL\_LIST) to view existing applicant lists.

Navigation:

**Recruiting > Applicant Lists**

This example illustrates the Applicant Lists page.

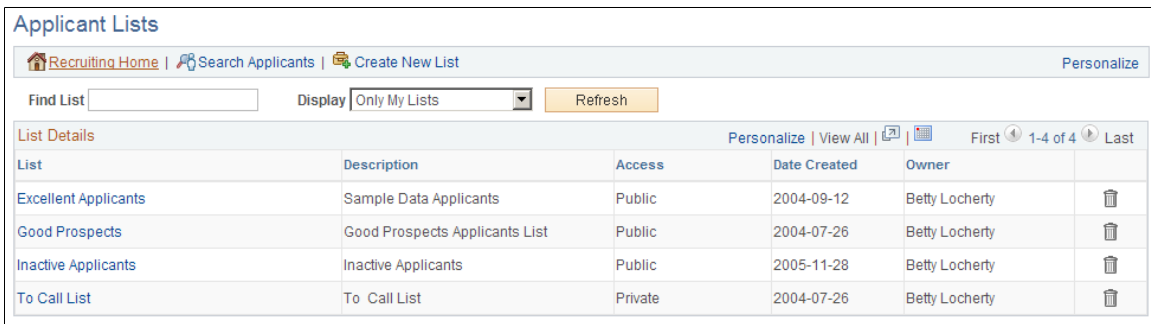

### Toolbar Buttons

<i>Field or Control</i>	<i>Description</i>
<b>Recruiting Home</b>	Click to access the Recruiting Home page.
<b>Search Applicants</b>	Click to access the Search Applicants page, where you can search for applicants and use the <i>Add Applicant to List</i> action to add applicants to lists.
<b>Create New List</b>	Click to create a new applicant list using the Create New List page.

### List Selection Options

<i>Field or Control</i>	<i>Description</i>
<b>Find List</b>	Enter a partial or full list name to search for that list and click <b>Refresh</b> button to display the search results.

<b>Field or Control</b>	<b>Description</b>
<b>Display</b>	Select which applicant lists you want to view and click the <b>Refresh</b> button to view those lists. Values are:  <i>Only My Lists:</i> Select to view only lists that you own.  <i>All Lists:</i> Select to view all public lists along with any private lists that you own.

## List Details

<b>Field or Control</b>	<b>Description</b>
<b>List</b>	Click a link to access the Manage Applicant List page, where you can view details for all applicants on the list.
<b>Description</b>	Displays the long description of the applicant list.
<b>Access</b>	Displays whether the list is public or private.
<b>Date Created and Owner</b>	Displays the name of the user that created the list and the date that the list was created.
 <b>Delete</b>	Click to delete an applicant list.

## Add to Applicant List Page

Use the Add to Applicant List page (HRS\_SELECT\_LIST) to select the applicant list to which you want to add an applicant.

Navigation:

- Click the **Add to List** toolbar button on the Manage Applicant page.
- Select the **Add to List** action or group action on the Manage Applicant List page.
- Select Add Applicant To List (or **Applicant Actions** > **Add Applicant to List**) from the row-specific action menu or the group action menu on any of these pages:
  - Search Applicants (all types of searches)
  - Search Applications
  - Manage Application

- Manage Job Opening

This example illustrates the Add to Applicant List page.

### Add to Applicant List

Select the list name that you would like to add the applicant(s) to or select the Create New List option to create a new list.

List Name	Description	Owner	Status	Access	Date Created
<a href="#">Good Prospects</a>	Good Prospects Applicants List	Betty Locherty	Active	Public	2004-07-26
<a href="#">To Call List</a>	To Call List	Betty Locherty	Active	Private	2004-07-26
<a href="#">Excellent Applicants</a>	Sample Data Applicants	Betty Locherty	Active	Public	2004-09-12
<a href="#">Inactive Applicants</a>	Inactive Applicants	Betty Locherty	Active	Public	2005-11-28
<a href="#">TAM Usability List</a>	TAM Usability List	Jacob Taylor	Active	Public	2012-01-16

[Return to Previous Page](#)

<i>Field or Control</i>	<i>Description</i>
<b>List Name</b>	<p>This page appears after you select one or more applicants and perform an action to add those applicants to a list. Click the name of a list, and the selected applicants are added to that list.</p> <p>The grid on the page shows both public lists and the user's own private lists.</p>
<b>Create New List</b>	<p>To create a new list for the selected applicants, click this button. After you enter list information on the Create New List page, the system automatically adds the applicants to the new list and displays the Manage Applicant List page.</p>

## Create New List Page

Use the Create New List page (HRS\_CREATE\_LIST) to create an applicant list.

Navigation:

Click the **Create New List** button on the Applicant Lists page or on the Add to Applicant List page.

This example illustrates the Create New List page.

### Name Your New List

<i>Field or Control</i>	<i>Description</i>
<b>List Name and Description</b>	Enter identifying information about the new list. Both the name and description appear on the Applicant Lists page. Only the name appears on the Manage Applicant List page.
<b>Status</b>	Select <i>Active</i> or <i>Inactive</i> . When a list is inactive, only the list owner can view the list, even if it is a public list. You cannot add applicants to inactive lists.
<b>Public</b>	Select this check box to make the list a public list. Deselect this check box to make the list private. Private lists are visible only to the creator. (Not even Recruitment Administrators can view other users' private lists.)

## Manage Applicant List Page

Use the Manage Applicant List page (HRS\_LIST\_MEMBER) to manage an applicant list and its membership.

Navigation:

Click a list name on the Applicant Lists page.

This example illustrates the Manage Applicant List page.

**Manage Applicant List**

[Return](#) | [Recruiting Home](#) | [Search Applicants](#) | [Edit List Details](#) | [Delete List](#) | [Create New List](#) [Personalize](#)

List Name: Good Prospects      Access: Public  
 Owner: Betty Locherty      Created On: 26 July 2004

Find Applicant:

**Applicants** [Personalize](#) | [Find](#) | [View All](#) | [Print](#) | [Refresh](#)      First 1-3 of 3 Last

	Name	Applicant ID	Preferred Contact	Most Recent Note	Note Created By	Add Note	Forward Applicant	Link to Job	Other Actions
<input type="checkbox"/>	Cindy Lee	1016	HCMGENUser1@ap60 23fems.us.oracle.com						Other Actions
<input type="checkbox"/>	Gregory Wu	1017	404/289-6754						Other Actions
<input type="checkbox"/>	Corey Williams	1018	HCMGENUser1@ap60 23fems.us.oracle.com						Other Actions

Select All   Deselect All   Group Actions

[Return](#) | [Recruiting Home](#) | [Search Applicants](#) | [Edit List Details](#) | [Delete List](#) | [Create New List](#) [Top of Page](#)



### Toolbar Buttons

<b>Field or Control</b>	<b>Description</b>
<b>Return</b>	Click to return to the previous page.
<b>Recruiting Home</b>	Click to access the Recruiting Home page.
<b>Search Applicants</b>	Click to access the Search Applicants page, where you can search for and select applicants to add to the list.
<b>Previous and Next</b>	These buttons are visible only when you access the page from the list of Applicant Lists on the Recruiting Home page. Use them to navigate to the previous and next lists.
<b>Edit List Details</b>	Click to access the Edit Primary List Information page, where you can change the list name, description, status, and availability (public or private).
<b>Delete List</b>	Click to delete the list. Only the list owner can delete the list.
<b>Create New List</b>	Click to create a new applicant list using the Create New List page.

## Find Applicant

<i>Field or Control</i>	<i>Description</i>
<b>Find Applicant and Go</b>	Enter the partial or full name of the applicant that you are searching for and click <b>Go</b> to display the search results.

## Applicants

<i>Field or Control</i>	<i>Description</i>
<check box>	Select the check box next to an applicant to include the applicant in any group action you perform on this page.  Below the <b>Applicants</b> grid, <b>Select All</b> and <b>Deselect All</b> links provide selection shortcuts.
<b>Name</b>	Click an applicant's name to access the Manage Applicant page for that applicant.
<b>Applicant ID</b>	Displays the applicant's unique identification number.
<b>Preferred Contact</b>	Displays the email address, phone number, or mailing address of the applicant, depending on the applicant's preferred contact method. You can update an applicant's preferred contact method on the Manage Applicant page: Applicant Data tab: Personal Information section.
<b>Most Recent Note</b>	Displays the date that the most recent applicant note was created.
<b>Note Created By</b>	Displays the name of the user who entered the most recent note.
 <b>Add Note</b>	Click to open the Applicant Notes page and create a new applicant note.
 <b>Forward Applicant</b>	Click to access the Forward Applicant page and forward the selected applicant.
 <b>Link to Job</b>	Click to open the <a href="#">Link Applicant to Job Opening Page</a> and link the applicant to selected job openings.

<b>Field or Control</b>	<b>Description</b>
<b>Other Actions</b>	<p>Click to display a menu of actions that you can perform for the applicant shown in the row. The following actions are available:</p> <ul style="list-style-type: none"> <li>• Add to Another List: displays the <a href="#">Add to Applicant List Page</a>.</li> <li>• Change Applicant Status displays the <a href="#">Change Applicant Status Page</a>.</li> <li>• Send Correspondence displays the <a href="#">Send Correspondence Page</a>.</li> </ul>

### Group Actions

<b>Field or Control</b>	<b>Description</b>
<b>Group Actions</b>	<p>Select an action from this related actions menu to perform the action on all selected applicants. The following actions are available:</p> <ul style="list-style-type: none"> <li>• Add Applicant to List displays the <a href="#">Add to Applicant List Page</a>.</li> <li>• Change Applicant Status displays the <a href="#">Change Applicant Status Page</a>.</li> <li>• Forward Applicant displays the <a href="#">Forward Applicant Page</a>.</li> <li>• Link Applicant to Job displays the <a href="#">Link Applicant to Job Opening Page</a>.</li> <li>• Send Correspondence displays the <a href="#">Send Correspondence Page</a>.</li> </ul> <hr/> <p><b>Note:</b> The number of rows that can be included in a group action can be limited using the Group Action Limit field on the <a href="#">Recruiting Installation – Applicants Page</a>. If a user attempts to perform a group action when too many rows are selected, the system displays a message informing the user of the limit and stating that only the allowed number of rows will be processed. If the user continues, the system processes the allowed number of rows, starting at the beginning of the list and following the grid sort order. Even if the user cancels, the system deselects all rows after the specified limit, and the user can review which rows will be processed before re-initiating the action with an allowable number of selected rows.</p> <hr/>

## Edit Primary List Information Page

Use the Edit Primary List Information page (HRS\_CREATE\_LIST) to edit information about the list such as its name and whether it is private or public.

Navigation:

Click the **Edit List Details** toolbar button on the Manage Applicant List page.

This example illustrates the Edit Primary List Information page.

This page is the same as the [Create New List Page](#). However, in edit mode, one additional field is visible.

<i>Field or Control</i>	<i>Description</i>
<b>Owner</b>	Displays the name of the list owner. If the <b>Access</b> field indicates that the list is private, the owner is the only user who can see this list. Even if the list is public, the owner is the only user who can modify the data on this page.

## Creating Applicant Checklists

This topic provides an overview of checklists and discusses how to create applicant checklists.

### Page Used to Create Applicant Checklists

<i>Page Name</i>	<i>Definition Name</i>	<i>Usage</i>
<a href="#">Applicant Checklist Page</a>	HRS_APP_CHKLIST	Create a checklist for an applicant.



## Understanding Checklists

A checklist helps you track a group of tasks that need to be performed. You can create multiple checklists for an applicant, but the checklists are associated with the applicant record, not with specific job applications.

Define standard checklists on the “Checklist Page” (PeopleSoft Human Resources Administer Workforce).

When you create an applicant checklist, you select a standard checklist to use. All of the associated checklist items are brought into your applicant checklist. Although each applicant checklist must reference a standard checklist, you can always add or delete individual checklist items to reflect the tasks that need to be done for a specific applicant.

## Applicant Checklist Page

Use the Applicant Checklist page (HRS\_APP\_CHKLST) to create a checklist for an applicant.

Navigation:

Select Manage Applicant Checklists (or **Applicant Actions** > **Manage Applicant Checklists**) from the Actions menu or the Other Actions menu on these pages:

- Manage Applicant
- Search Applications
- Manage Application
- Manage Job Opening

This example illustrates the Applicant Checklist page.

**Applicant Checklist**

Applicant Name: Neil Keitt      Applicant ID: 500270  
 Applicant Type: External Applicant      Empl ID:

**Applicant Information**      Find | View All      First 1 of 1 Last

\*Checklist Date: 11/10/2014      Delete Checklist  
 \*Checklist: KF0001      Applicant Checklist  
 Responsible ID:      Comment:

*Sequence	*Item Code	Description	*Briefing Status	*Status Date
100	K00033	Resume on hand	Initiated	11/10/2014
200	K00034	Interview testing set up	Initiated	11/10/2014
300	K00035	References contacted	Initiated	11/10/2014
400	K00036	Verify employment history	Initiated	11/10/2014
500	K00037	Proof of Education	Initiated	11/10/2014
600	K00038	Licence/Certification verified	Initiated	11/10/2014
700	K00039	Offer Letter generated	Initiated	11/10/2014
800	K00040	Acceptance received	Initiated	11/10/2014
900	K00041	Start Date confirmed	Initiated	11/10/2014

Add Checklist Item      Add Checklist      Save      Cancel

This page is an applicant-oriented version of the Person Assignment Checklist page in PeopleSoft Human Resources Administer Workforce.

See “Person Assignment Checklist Page” (PeopleSoft Human Resources Administer Workforce).

<b>Field or Control</b>	<b>Description</b>
<b>Checklist</b>	Select a standard checklist. The system populates the Checklist Item grid with the associated items.  This field is required, but you can always add or remove specific checklist items.

## Adding Persons of Interest

This topic provides an overview of persons of interest and discusses how to add a person of interest record for an applicant.

See “Understanding Search/Match” (Application Fundamentals)

## Pages Used to Add Persons of Interest

<i>Page Name</i>	<i>Definition Name</i>	<i>Usage</i>
<a href="#">Add Person of Interest Page</a>	HRS_ADD_EXT_TRN	Create an HR person of interest record for an applicant.
<a href="#">Search Results Page</a>	HCR_SM_RESULTS	View Search/Match results and investigate potential matches.

## Understanding Persons of Interest

In some situations, your organization may wish to add applicants to the human resources system as persons of interest before the applicants are actually hired. To add an applicant as a person of interest, use the *Add Person of Interest* action. This action is available only for external applicants. You cannot add internal applicants (employees or non-employees) as persons of interest because they already exist in the HR system.

Depending on whether the Person of Interest field on the [Recruiting Installation – Applicants Page](#) is set to *Yes* or *No*, you may be required to check whether the applicant is already in the human resources database. When checking is required, submitting an applicant as a person of interest causes the system to search the HR system and display a list of potential matches. You review this list and, if you find a match, you identify the record so that the system can associate the applicant with the existing record rather than creating a new record.

See [Recruiting Installation – Applicants Page](#).

After you add an applicant as a person of interest, you can confirm the transaction by verifying that the system has added an **EmplID** field to the Manage Applicant page: Applicant Data tab: Personal Information section.

## Add Person of Interest Page

Use the Add Person of Interest page (HRS\_ADD\_EXT\_TRN) to create an HR person of interest record for an applicant.

Navigation:

Select **Applicant Actions** > **Add POI** from the Other Actions menu on the Manage Applicant page.

This example illustrates the Add Person of Interest page.

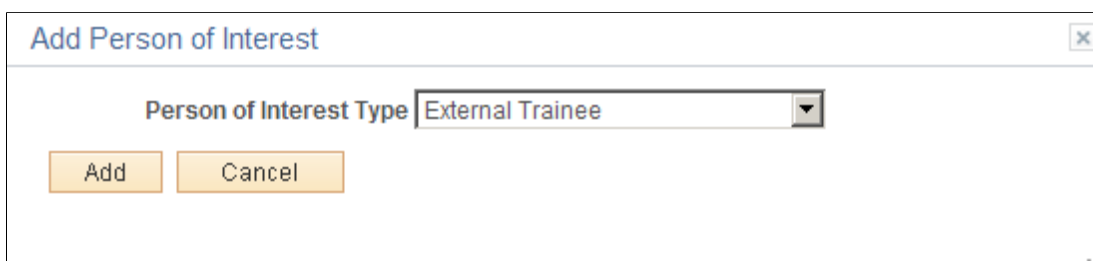

<i>Field or Control</i>	<i>Description</i>
<b>Person of Interest Type</b>	Select the person of interest type that you want to assign to the applicant. Define person of interest types on the “Person of Interest Types Page” (Application Fundamentals).

## Search Results Page

Use the Search Results page (HCR\_SM\_RESULTS) to view Search/Match results and investigate potential matches.

Navigation:

Click the **Submit** button on the Add Person of Interest page.

The Search Results page appears if the system is configured to search the system to see if the person you are adding already exists in the system.

See [Search Results Page](#).

---

## Completing Pre-Employment Checks

This topic provides an overview of pre-employment checks, lists a prerequisite, and discusses how to submit pre-employment check requests.

### Pages Used to Complete Pre-Employment Checks

<i>Page Name</i>	<i>Definition Name</i>	<i>Usage</i>
<a href="#">Pre-Employment Check Page</a>	HRS_PREEMPL_H	Submit pre-employment check requests.
Pre-Employment Check Details	HRS_PREEMPL_D	Review pre-employment check details.

## Understanding Pre-Employment Checks

Some organizations may use third-party vendors to perform pre-employment checks on applicants. When your organization sets up an agreement with a pre-employment check vendor, you nominate a recruiting administrator or recruiter as the HR manager for your organization. The HR manager has access to the administration functions to define the privileges of other users with access to the pre-employment vendor.

### Prerequisite

Before you can request pre-employment checks, you must set up a vendor that performs pre-employment checks.

See [Setting Up Recruiting Vendors](#).

## Pre-Employment Check Page

Use the Pre-Employment Check page (HRS\_PREEMPL\_H) to submit pre-employment check requests.

Navigation:

Select **Other Actions** > **Applicant Actions** > **Pre-Employment Check** on any of these pages:

- Manage Applicant
- Search Applications
- Manage Application
- Manage Job Opening

This example illustrates the Pre-Employment Check page.

### Pre-Employment Check

**Applicant**

<b>Name</b> Henrietta Bourallee	<b>Preferred Contact</b> None
<b>Applicant ID</b> 500008	<b>Phone</b>
<b>Applicant Type</b> External Applicant	<b>Email</b>
<b>Status</b> 010 Active	<b>Address</b>

**Background Screening Provider**  Request New Inquiry

[Return to Previous Page](#)

<b>Field or Control</b>	<b>Description</b>
<b>Background Screening Provider</b>	Select the provider that is to perform the background check.
<b>Request New Inquiry</b>	Click to submit the request. The system sends a message to the vendor.

## Screening Inquiries

This grid displays the summary information and status of the background check.

<b>Field or Control</b>	<b>Description</b>
<b>Adjudication Status</b>	Displays the status of the adjudication, if you have enabled it on the Open Integration Framework - Pre-Employment Vendor Setup page.  See <a href="#">Pre-Employment Vendor Setup Page</a> .
<b>Details</b>	Click to access the Pre-Employment Check Details page, where you can review status information for the pre-employment checks.

## Creating Applicant Contracts

This topic provides an overview of applicant contracts, lists prerequisites, and discusses how to manage applicant contracts.

### Pages Used to Manage Applicant Contracts

<i>Page Name</i>	<i>Definition Name</i>	<i>Usage</i>
<u>Contract Status/Content Page</u>	HRS_APP_CNTRCT1	Define basic contract information.
<u>Contract Clause Page</u>	HRS_APP_CNTRCT2	Define contract clause information.
<u>Signature Date/Probation Info Page</u>	HRS_APP_CNTRCT3	Define the signature date and probation information.

### Understanding Applicant Contracts

If your organization uses employment contracts, you can use Talent Acquisition Manager to create applicant contracts and link them to an applicant during the prepare for hire process. If the employee is hired, this information is copied to the human resources database.

The pages for managing applicant contracts are similar to the pages for managing employee contracts. To access these pages, use the Manage Applicant Contracts action.

**Note:** The Manage Applicant Contracts action is not available to hiring managers. This restriction is based on users who have PeopleTools roles that are associated with the Hiring Manager recruiting role type.

See [Understanding Recruiting Security](#).

### Prerequisites

Before you create an applicant contract, you must:

- Set up contract types.
- Set up contract clauses.
- Set up contract templates.

See “Setting Up Workforce Contracts” (PeopleSoft Human Resources Administer Workforce).

### Contract Status/Content Page

Use the Contract Status/Content page (HRS\_APP\_CNTRCT1) to define basic contract information.

Navigation:

Select **Other Actions** > **Applicant Actions** > **Manage Applicant Contracts** on any of these pages:

- Manage Applicant
- Search Applications
- Manage Application
- Manage Job Opening

This example illustrates the Contract Status/Content page.

The screenshot displays the 'Contract Status/Content' page for an applicant. At the top, there are three tabs: 'Contract Status/Content' (selected), 'Contract Clause', and 'Signature Date/Probation Info'. Below the tabs, the applicant's name 'Henrietta Bourallee' and ID '500008' are shown, along with the type 'External Applicant' and 'Empl ID'. The main section is titled 'Applicant Information' and includes a search bar with 'Find | View All' and pagination 'First 1 of 1 Last'. The form contains several fields: '\*Contract Number' (0001), '\*Contract Status' (Active), 'Contract Begin Date' (02/07/2013), 'Contract End Date', 'Contract Expected End Date', '\*Regulatory Region' (USA), and 'Contract Template ID'. There are also checkboxes for 'Additional Contract' and 'More than one year expected', a 'Comment' field, and an 'Initialize Contract' button. At the bottom, there is a 'Save' button and a 'Return to Previous Page' link. A small flag icon for Spain is visible in the bottom left corner.

This page is similar to the “Contract Status/Content Page” (PeopleSoft Human Resources Administer Workforce) for employees.

## Contract Clause Page

Use the Contract Clause page (HRS\_APP\_CNTRCT2) to define contract clause information.

Navigation:

Select **Other Actions** > **Applicant Actions** > **Manage Applicant Contracts** on any of these pages:

- Manage Applicant
- Search Applications
- Manage Application
- Manage Job Opening

Continue to the Contract Clause page.

This example illustrates the Contract Clause page.

This page is similar to the “Contract Type/Clauses Page” (PeopleSoft Human Resources Administer Workforce) for employees.

## Signature Date/Probation Info Page

Use the Signature Date/Probation Info (signature date/probation information) page (HRS\_APP\_CNTRCT3) to define the signature date and probation information.

Navigation:

Select **Other Actions** > **Applicant Actions** > **Manage Applicant Contracts** on any of these pages:

- Manage Applicant
- Search Applications
- Manage Application
- Manage Job Opening

Continue to the Signature Date/Probation Info page.



This example illustrates the Signature Date/Probation Info page.

The screenshot displays a web form with the following sections and fields:

- Contract Status/Content** | **Contract Clause** | **Signature Date/Probation Info** (selected)
- Applicant Name:** Henrietta Bourallee | **Applicant ID:** 500008
- Applicant Type:** External Applicant | **Empl ID:**
- Applicant Information** (Find | View All | First 1 of 1 Last)
  - Contract Number:** 0001 | **Begin Date:** 02/07/2013 | **Contract Status:** Active (+ -)
  - Signature Date:** [Text Field] [Calendar Icon]
  - Maximum Hours:** 40.00 | **Minimum Hours:** 10.00
  - Responsible ID:** [Text Field] [Search Icon]
- Probation Info**
  - Probation Date:** [Text Field] [Calendar Icon]
  - Reason:** [Dropdown Menu]
- Buttons:** Save, Return to Previous Page

This page is similar to the “Contract Data - Signature Date/Probation Info Page” (PeopleSoft Human Resources Administer Workforce) for employees.

## (AUS) Creating Salary Packages

Salary package modelling enables you to explore different package scenarios to find satisfactory solutions and alternatives for applicant salary packages. You can save and report on any number of package variations during the modelling process.

You can model a salary package at any point in the recruiting process. When modelling salary packages for applicants, combine any number or type of components into a package to suit both the organization and applicant.

In PeopleSoft Talent Acquisition Manager, recruiting administrators can model salary packages using the Create Salary Package Model action. To perform this action, select **Other Actions > Recruiting Actions > Create Salary Package Model** on any of these pages:

- Manage Applicant
- Search Applications
- Manage Application
- Manage Job Opening

This action is available only when PeopleSoft Global Payroll for Australia is an installed product.

For information about the pages used to model salary packages, see “Modelling Salary Packages for Applicants” (PeopleSoft Human Resources Administer Salary Packaging).

## (AUS) Copying Salary Packages to Human Resources

If you used the Create Salary Package action to model a salary package for an applicant, you can copy that salary package to the human resources system after the applicant has been hired.

In PeopleSoft Talent Acquisition Manager, recruiting administrators can copy the applicant salary package to employee record using the Copy Salary Package action. To perform this action, select **Other Actions** > **Applicant Actions** > **Copy Salary Package** on any of these pages:

- Manage Applicant
- Search Applications
- Manage Application
- Manage Job Opening

This action is available to administrators only. It is available when:

- PeopleSoft Global Payroll for Australia is an installed product.
- The applicant's disposition is *Hired*.
- The salary package has not yet been copied to the HR system.

See “Copying Applicant Salary Packages to the Employee Salary Package Component” (PeopleSoft Human Resources Administer Salary Packaging).

## Processing Duplicate Applicants

This topic provides an overview of duplicate applicant processing and discusses how to identify and merge applicant records.

### Pages Used to Process Duplicate Applicants

<b>Page Name</b>	<b>Definition Name</b>	<b>Usage</b>
<a href="#">Process Duplicate Applicants Page</a>	HRS_DUPE_PRC	Create new instances of the duplicate applicant search process and access the results of those searches.
<a href="#">Find Duplicate Applicants Page</a>	HRS_DUPE_FIND	Select fields for duplicate matching and initiate the process of searching for duplicates.
<a href="#">Review Duplicate Applicants Page</a>	HRS_DUPE_REVIEW	Review potential duplicates, choose source and target applicants for merging, and initiate the merge process.

<b>Page Name</b>	<b>Definition Name</b>	<b>Usage</b>
<u>Merge Applicant Page</u>	HRS_APP_MERGE	Merge the selected applicant record with one or more other applicants that you identify.

## Understanding Duplicate Applicant Processing

Sometimes an applicant has more than one record, each with its own applicant ID. Duplicate applicant records can occur when applicants register in Candidate Gateway more than once or when they submit their applications using different methods. For example, an applicant who was hired for short-term seasonal work might create a new Candidate Gateway account when applying to return to your organization the following year, resulting in both an active applicant record and a hired applicant record.

Talent Acquisition Manager provides two mechanisms for merging duplicate records:

- Automated processes that help recruiters identify potential duplicates and merge selected records.
- A manual merge process that recruiters can initiate from within an applicant record.

### Target and Source Records

The following diagram illustrates the process of merging duplicate records. In the diagram, there are initially two different applicant IDs representing the same applicant. One record is marked as the *Target* record; this record will be updated with data from the other records and will remain active after the merge process. The other record is marked as the *Source* record; its data will be copied over to the target record and it will become inactive after the merge process. Each record is associated with a different job opening. When the records are merged, the surviving applicant record is automatically associated with both job openings.

This diagram illustrates the merging of data from two applicant records. The merge process relates all associated job openings to the surviving applicant.

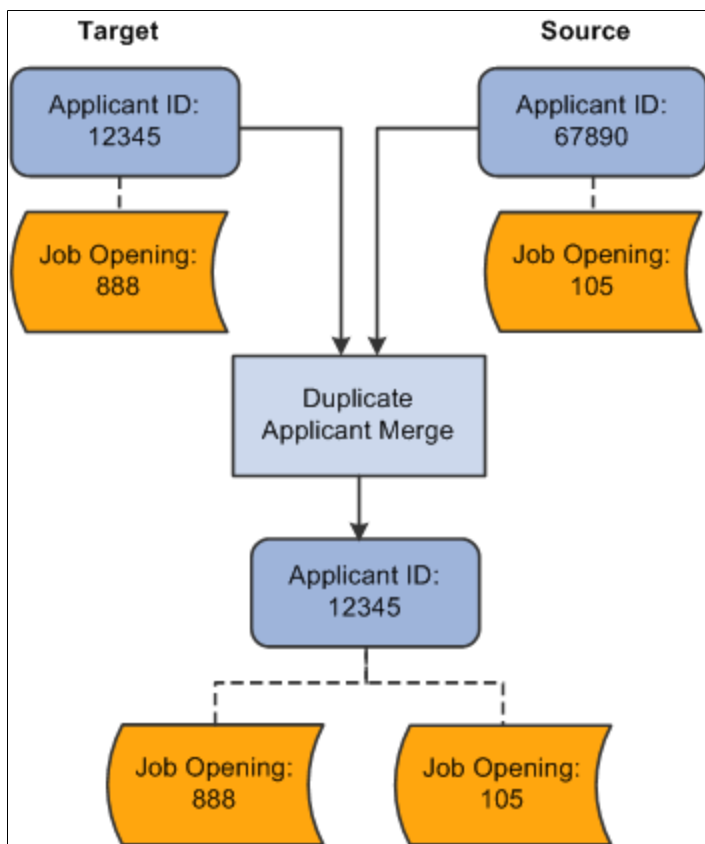

Source records still exist after being merged, but they are assigned an inactive status. Use the [Recruiting Installation – Applicants Page](#) to configure the inactive status to assign to the duplicate records.

## Automated Processes for Managing Duplicate Records

The system provides two Application Engine processes that work together to help you manage duplicate records:

- The Find Applicant Duplicates (HRS\_DUP\_PRC) process uses search criteria that you specify to find potential duplicates.

For example, if you search on first and last name, the process results will include groups of potential duplicates whenever there are multiple applicants with the same first and last name. The process does *not* automatically merge these potential duplicates; you must review the results and identify targets and sources when you determine that there is, in fact, duplication.

- The Duplicate Applicant Merge process (HRS\_DUPE\_MRG) completes the data merge for the records that you have marked.

To use these processes for duplicate applicant processing:

1. Access the Process Duplicate Applicants page (**Recruiting > Administration > Process Duplicate Applicants > Process Duplicate Applicants**).

This page lists previous instances of the Find Applicant Duplicates process. All instances except the most recent have a *Closed* status, and the most recent instance will automatically be closed when you create a new instance.

2. Click the **Create New Search** button to access the Find Duplicate Applicants page, where you specify criteria to be used in identifying potential duplicates.
3. Select your search criteria and click the **Run** button to initiate the Find Applicant Duplicates process.

This process finds potential duplicate applicant records that match the search criteria that you define. Email, address, and middle name searches are case-sensitive.

For the system to consider two applicants a match, all search criteria that you define on the Find Duplicate Applicants page must match exactly. Records with duplicate email addresses, phone, and national ID numbers, regardless of type, are identified as potential duplicate records. For example, if one applicant record has a home email address that matches the business email address from another applicant record, the system counts this as a potential match regardless of the fact that the address types are different.

The process runs against active applicant records only: it does *not* include applicant records in the status that the [Recruiting Installation – Applicants Page](#) identifies as the inactive status for duplicates. This restriction prevents records that were inactivated during previous merges from reappearing in your search results. If you need to merge an inactive applicant record, use the manual merge process.

4. Return to the Process Duplicate Applicants page and click the **View Duplicates** link to access the Review Duplicate Applicants page, then review the process results and identify records to merge.

The system groups each set of potential duplicate applicants into duplicate sets. If you determine that the applicants in a duplicate set are in fact duplicates, identify which applicant records will survive the merge and mark them as target records. Mark records that are to be merged into the target as source records, and explicitly identify the matching target record. For each duplicate set, there can be multiple source and target records.

To determine which records should be merged, you might need to review detailed information about a record. To do this, click the applicant record ID to access the Manage Applicant page.

5. Click the Run button on the Review Duplicate Applicants page to run the Duplicate Applicant Merge process and complete the merge for any records that you have marked for merging.

If you return to the Review Duplicate Applicants page after the process is complete, the merged applicant records are read-only. Unmerged applicant records, however, are still editable. You can continue to identify target and source records and run the Duplicate Applicant Merge process as long as there are still unmerged applicants on the page.

## Manual Merges

If you have already identified duplicate records, you can manually merge them without running the search process that finds potential duplicates for you. To do this, access the Manage Applicant page for one of the duplicate records, then click the Merge Applicants toolbar button to access the Merge Applicant page, where you define the source and target applicant records and initiate the merge.

During a manual merge, the system displays a message to update applicant list. The user can choose to merge applicants with or without applicant list update.

---

**Note:** Manual merges also use the Duplicate Applicant Merge Application Engine process (HRS\_DUPE\_MRG), however, you do not use the Process Scheduler Request page to initiate the process. Rather, the system automatically initiates the process when you click the **Merge** button.

---

## Data Merging

When you merge applicant records, the following data changes occur:

- The status and reason for the source applicant records is set to the status and reason entered in the **Inactive State for Duplicates** and **Status Reason for Duplicates** fields respectively on the Recruiting Installation – Applicants page.

See [Recruiting Installation – Applicants Page](#).

- If a source applicant has a Candidate Gateway account, the account status is updated to indicate that the account is a duplicate and cannot be used or reactivated.
- The system updates the target record with the most current contact information (first name, middle name, last name, address, phone numbers, email addresses) and identity and eligibility data.

If there is no data on the target record, but there is data on the source record, the system uses the data on the source record to update the target record. If data on the source and target records has the same effective date, the system does not change the data on the target record.

- Unique recruitment rows from the source records are added to the target record so that there is no loss of data.

This includes interview schedules, interview evaluations, contact notes, expenses, interested parties, references, and referral sources. However, offer approval data is not transferred to the target record.

---

**Note:** If you merge records for internal applicants (employees and non-employees), the system modifies the applicant record only. Information held in Personal Data tables is never changed.

---

## Offer Approval Handling During a Merge

Offer approval data cannot be transferred to the target record. To help you avoid losing important data, the grids that list applicants to be merged all include a column with information about whether an offer approval exists.

During a manual merge, if any of the source records have offer approvals, the system displays a warning. The user can choose whether to cancel or whether to continue with the loss of the approval data.

During an automated merge, the user can choose whether to automatically exclude applicants with offer approvals from the merge process. Also, the system creates a log file containing information about the applicants with offer approval processes. The log file gets created regardless of whether the applicants were excluded from the merge, and the log file starts with text that states whether the applicants were excluded. The log includes identifying information about the applicant, the offer, and the approval process.

## Process Duplicate Applicants Page

Use the Process Duplicate Applicants page (HRS\_DUPE\_PRC) to create new instances of the duplicate applicant search process and access the results of those searches.

Navigation:

**Recruiting > Administration > Process Duplicate Applicants > Process Duplicate Applicants**

This example illustrates the Process Duplicate Applicants page.

## Process Duplicate Applicants

▶ [Select to View Instruction](#)

Create New Search
Refresh

### Review Duplicate Processes

Run Control ID	Last Updated	Status	View Duplicates
HRS_DUPE_FIND_2	01/25/2013 2:42PM	Search Requested	<a href="#">View Duplicates</a>
HRS_DUPE_FIND_1	05/01/2006 3:41PM	Review in Progress	<a href="#">View Duplicates</a>

Create New Search
Refresh

## Page-Level Actions

<i>Field or Control</i>	<i>Description</i>
<b>Create New Search</b>	Click this button to access the Find Duplicate Applicants page, where you can select new duplicate applicant search criteria and run the Find Applicant Duplicates process.
<b>Refresh</b>	Click to refresh the status links with the current status of the process.

## Review Duplicate Processes

<b>Field or Control</b>	<b>Description</b>
<b>Status</b>	<p>Displays the status of the process instance. Click a status link to access the Find Duplicate Applicants page, where you can review the duplicate applicant search criteria used for the process.</p> <p>Values are:</p> <ul style="list-style-type: none"> <li>• <i>Search Requested</i>: Indicates that the Find Applicant Duplicates process has been initiated.</li> <li>• <i>Search In Progress</i>: Indicates that the Find Applicant Duplicates process is running.</li> <li>• <i>Search Completed</i>: Indicates that the Find Applicant Duplicates process is complete but that the results have not been reviewed.</li> <li>• <i>Review In Progress</i>: Indicates that the results of the Find Applicant Duplicates process are being reviewed. The system assigns this status when you click the <b>View Duplicates</b> link for the process.</li> <li>• <i>Merge Completed</i>: Indicates that the Duplicate Applicant Merge process has finished running.</li> </ul> <p>You can continue run the merge process on additional sets of duplicate records.</p> <ul style="list-style-type: none"> <li>• <i>Closed</i>: Indicates that the search is closed. The system assigns this status to queued or pending processes when you run the Find Applicant Duplicates process for a new process. Only one process can be active at a time. This ensures data integrity and avoids process conflicts among target and source applicants during the merge.</li> </ul>
<b>View Duplicates</b>	<p>Click to access the Review Duplicate Applicants page, where you can identify duplicate sets and merge duplicate applicant records. This link appears after the Find Applicant Duplicates process is complete.</p>

## Find Duplicate Applicants Page

Use the Find Duplicate Applicants page (HRS\_DUPE\_FIND) to select fields for duplicate matching and initiate the process of searching for duplicates.

Navigation:

- Click the **Create New Search** button on the Process Duplicate Applicants page.



- Click a link in the **Status** column on the Process Duplicate Applicants page.

**Note:** Once you initiate the Find Applicant Duplicates process, this page becomes read-only. You must then create a new search to establish new search criteria.

This example illustrates the Find Duplicate Applicants page (1 of 2).

Process Duplicate Applicants

---

### Find Duplicate Applicants

Run Control ID HRS\_DUPE\_FIND\_3 [Report Manager](#) [Process Monitor](#) Run

- First Name
- Middle Name
- Last Name
- Second Last Name
- Alternate Character Name
- Phone
- Email
- Date of Birth
- Gender
- National ID

This example illustrates the Find Duplicate Applicants (2 of 2).

- Address Line 1
- Address Line 2
- Address Line 3
- Address Line 4
- City
- County
- Postal Code
- State
- Country
- Address Field 1
- Address Field 2
- Address Field 3
- Number 1
- Number 2
- House Type
- In City Limit
- Tax Vendor Geographic
- Alternate Character Address 1
- Alternate Character Address 2
- Alternate Character Address 3
- City Alternate Character

Save [Return to Main Page](#)

<b>Field or Control</b>	<b>Description</b>
<b>&lt;Applicant Data Fields&gt;</b>	<p>Select the data that must be identical for applicants to be considered as duplicates. When you first access this page for new duplicate processing, the search settings are copied from the settings for the previous search.</p> <p>Email, address, and middle name searches are case-sensitive.</p> <p>Records with duplicate and national ID numbers, email addresses, and phone numbers, regardless of type, are identified as potential duplicate records. For example, if one applicant record has a home email address that matches the business email address from another applicant record, the system counts this as a potential match regardless of the fact that the address types are different.</p>
<b>Run</b>	Click to access the Process Scheduler Request page, where you initiate the duplicate search process.

## Review Duplicate Applicants Page

Use the Review Duplicate Applicants page (HRS\_DUPE\_REVIEW) to review potential duplicates, choose source and target applicants for merging, and initiate the merge process.

Navigation:

- Click the **View Duplicates** link on the Process Duplicate Applicants page.
- Select **Group Actions > Applicant Actions > Merge Applicants** on the Manage Job Opening page: Applicants tab.
- Click the **Merge** button on the Manage Job Opening page: Applicant Screening tab: Screening Results section.

This example illustrates the Review Duplicate Applicants page.

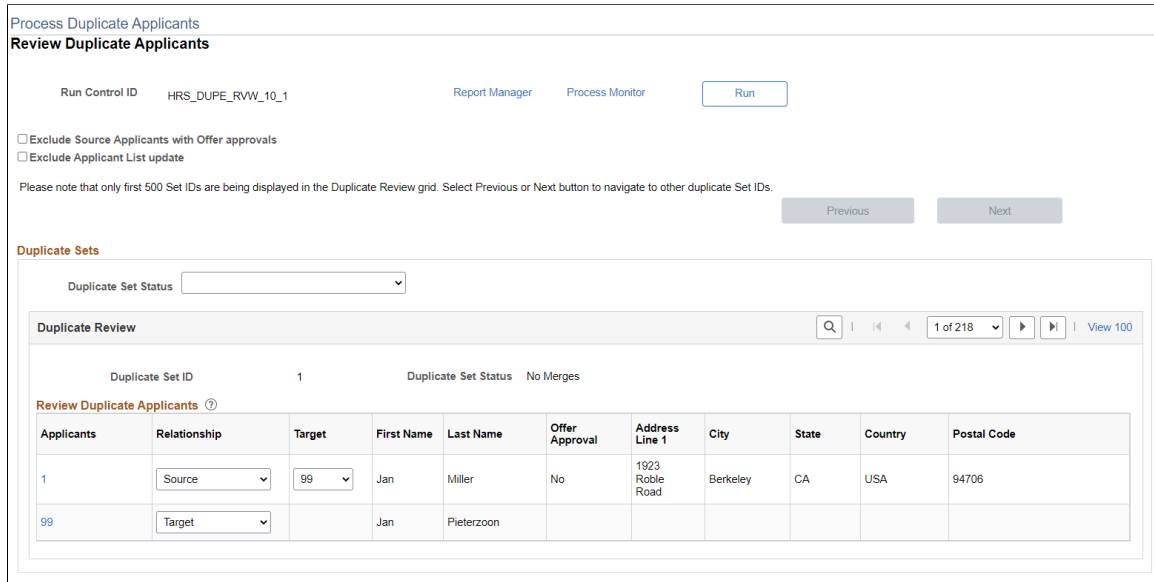

<b>Field or Control</b>	<b>Description</b>
<p><b>Run</b></p>	<p>After you have reviewed potential duplicates and identified records that you want to merge, click the <b>Run</b> button to initiate the Duplicate Applicant Merge process and complete the merge for the indicated records.</p> <p>You can process subsets of the potential duplicates. For example, you can run the process for the first 10 duplicate sets and then the rest at a later time.</p> <hr/> <p><b>Note:</b> After you start the Duplicate Applicant Merge process, you cannot cancel it. You must be certain that you want to merge the applicant records before you schedule the process.</p>
<p><b>Exclude Source Applicants with Offer Approvals</b></p>	<p>Select this check box if you do not want to merge source applicants who have offers with approval processes. Approval information is not copied to the target applicant during a merge, so excluding source applicants with offer approvals prevents the system from copying offers without the accompanying approval information.</p> <p>If any source applicants have offer approvals, the system creates a log file containing information about these applicants. The log gets created regardless of whether the applicants were excluded from the merge, and the log file header states whether the applicants were excluded. The log includes identifying information about the applicant, the offer, and the approval process.</p>
<p><b>Exclude Applicant List update</b></p>	<p>Select this check box if you want to merge applicants without an applicant list update during the Duplicate Applicant Merge process.</p>

<b>Field or Control</b>	<b>Description</b>
<b>Previous and Next</b>	<p>This page lists a maximum of 500 sets of duplicates. If more than 500 sets of duplicates exist, use the <b>Previous</b> and <b>Next</b> buttons to navigate to the previous or next sets of duplicate applicants.</p> <hr/> <p><b>Note:</b> The merge process includes all sets of duplicates where sources and targets have been identified, regardless of whether the set is included in the currently visible list of 500 sets.</p> <hr/>
<b>Duplicate Set Status</b>	<p>By selecting a value in this field, you can filter the data in the Duplicate Review scroll area based on the status of the duplicate set. The possible statuses (and thus the available filter values) are <i>Error</i>, <i>Merged</i>, <i>No Merges</i>, and <i>Ready for Merge</i>.</p>

## Duplicate Review

Use this group box to specify how the system merges duplicate applicant records. Applicants with matching data are grouped into duplicate sets. Review each set and decide if the applicant records are duplicates.

<b>Field or Control</b>	<b>Description</b>
<b>Duplicate Set ID</b>	<p>Displays the ID number for the duplicate set. Refer to the group box header to see how many total duplicate sets exist.</p>
<b>Duplicate Set Status</b>	<p>Displays the status of the merge process. Values are <i>Error</i>, <i>Merged</i>, <i>No Merges</i>, and <i>Ready for Merge</i>.</p>

## Review Duplicate Applicants

<b>Field or Control</b>	<b>Description</b>
<b>Applicants</b>	<p>Click the applicant ID link to access the Manage Applicant page, where you can view additional details for the applicant. (On the Manage Applicant page, clicking the <b>Applicant List</b> link returns you to the Review Duplicate Applicants page.)</p>

<b>Field or Control</b>	<b>Description</b>
<b>Relationship</b>	<p>Specify how the applicant records are merged. Values are <i>Source</i> and <i>Target</i>. For each duplicate set, there can be multiple source and target records. You cannot edit these fields after you run the Duplicate Applicant Merge process and merge the applicants.</p> <p>Leave these fields blank if you determine that the applicants in a duplicate set are not duplicates or if you have not yet made a determination.</p>
<b>Target</b>	<p>Select the target for each source record. The drop-down list box lists the applicant IDs for applicants in the same duplicate set who have been identified as targets.</p> <p>This column becomes visible after you select <i>Source</i> in the <b>Relationship</b> column for an applicant. The field is available only for source applicants.</p>
<b>Offer Approval</b>	<p>Displays <i>Yes</i> if the applicant has an offer that has an approval process, regardless of the status of that approval process.</p> <p>Displays <i>No</i> if the applicant has an offer that does not have an approval process. This occurs if offer approval functionality was not active when the offer was created.</p> <p>This field is blank if the applicant does not have an offer.</p>

## Merge Applicant Page

Use the Merge Applicant page (HRS\_APP\_MERGE) to merge the selected applicant record with one or more other applicants that you identify.

Navigation:

On the Manage Applicant page, click the Merge Applicants toolbar button.

This example illustrates the Merge Applicant page when you select the Merge as Source option, which uses the selected applicant as the source applicant for the merge.

The screenshot shows the 'Merge Applicants' interface. At the top, there is a section for the current applicant's details:

- Applicant:** Name: Carmichael Espinosa, Preferred Contact: None, Applicant ID: 500067, Phone: 925/694-7915, Applicant Type: Employee, Email: HCMGENUser1@ap6023fems.us.oracle.com, Status: 010 Active, Address: 4122 West Avenue, San Antonio, TX 78220.

Below this is the 'Merge Details' section, which contains a table with columns for Applicant ID, First Name, Last Name, Offer Approval, Relationship, Address Line 1-4, City, State, Country, and Postal Code. Two rows are listed:

Applicant ID	First Name	Last Name	Offer Approval	Relationship	Address Line 1	Address Line 2	Address Line 3	Address Line 4	City	State	Country	Postal Code
500067	Carmichael	Espinosa	Yes	Target	4122 West Avenue				San Antonio	TX	USA	78220
1019	Carmichael	Espinosa		Source	4122 West Avenue				San Antonio	TX	USA	78220

Buttons for 'Add Applicant', 'Merge', and 'Cancel' are visible at the bottom of the merge details section.

### Applicant

This group box displays information about the current applicant. This is the applicant from whose record you clicked the Merge Applicants toolbar button.

### Merge Details

This grid lists the applicant records to be merged. The current applicant is automatically listed. The user manually adds other applicant records.

Field or Control	Description
<b>Applicant ID</b>	Enter the unique identifier for the applicant record that is to be included in the merge process.
<b>Offer Approval</b>	Displays <i>Yes</i> if the applicant has an offer that has an approval process, regardless of the status of that approval process.  Displays <i>No</i> if the applicant has an offer that does not have an approval process. This occurs if offer approval functionality was not active when the offer was created.  This field is blank if the applicant does not have an offer.
<b>Relationship</b>	Select <i>Target</i> for the target row for the merge. Only one row can be designated as the target.  Select <i>Source</i> for all source rows for the merge.  The default row that is created for the current applicant has a default relationship of <i>Source</i> , but rows that you manually add do not have a default relationship.
<b>Add Applicant</b>	Click this button to add a new row to the list of applicants to be merged.

## Merge Button

<b>Field or Control</b>	<b>Description</b>
<b>Merge</b>	<p>Click to run the Duplicate Applicant Merge process and complete the merge.</p> <p>The system displays a message to update the applicant list. The user can choose to merge applicants with or without applicant list update.</p> <p>If any of the source applicants have offer approval processes (indicated by a <i>Yes</i> value in the <b>Offer Approval</b> field), a warning indicates that the offer approval information will not be merged. You can continue anyway, or you can cancel the merge.</p>





## Chapter 28

# Managing Resumes

---

## Understanding Resume Management

This overview discusses:

- Channels.
- Resume extraction process.
- Resume statuses.

### Channels

Applicant resumes can come into the Recruiting Solutions system from one of these channels:

- Email.
- Resume Load Process Application Engine process (HRS\_RESLOAD).
- Job boards and service providers.
- Apply online.
- Create Applicant (HRS\_ADD\_APPLICANT) component.

Resume Management supports all resume document formats and will accept HR-XML resumes from all channels. However, only OIF uses the data within the HR-XML document to directly write data to Recruiting Solutions tables. The other processes route the document to a resume extractor for processing. Not all resume extractors support all resume document formats. If the resume extractor doesn't support the resume document format, the resume extraction process fails.

### Email

Applicants and staffing suppliers can email resumes to a designated email address that you set up.

See [Setting Up Resume Email Accounts](#).

### Resume Load Process Application Engine Process (HRS\_RESLOAD)

The Resume Load Process enables organizations to load resumes that it receives.

See [Loading Resumes](#).

## Open Integration Framework

OIF is used to receive web services from staffing suppliers (job boards, recruitment agencies, and services procurement providers) which may contain either a candidate HR-XML or an unstructured resume as an attachment. For example, a recruitment agency that your organization integrates with can send XML resumes through the OIF. Because the agency sends an XML resume file, the system does not need to perform any extraction. Instead, the system uses the data directly from the XML resume file to process through Recruiting Solutions. Although no extraction is performed on the XML resumes, the resumes still go through data mapping and any other business process that you have set up for the staffing supplier.

When a staffing supplier submits a resume, it is common not to contact the applicant to whom the resume belongs. Instead, all communication with the applicant, up until the interview with the applicant, is done through the staffing supplier. The person at the staffing supplier organization who handles this duty is referred to as a proxy. The proxy takes on all responsibilities of the applicant and is both responsible and expected to act in the best interest of the applicant. On system pages that show applicant contact information, the contact information for the proxy is also included. When you send correspondence to an applicant that uses a proxy, the system sends the correspondence to the proxy, not the applicant.

To use OIF to receive resumes, the staffing supplier organization must set up web services and deliver the configuration file that you will use to set up the vendor.

To set up OIF to receive incoming candidates in Talent Acquisition Manager:

1. Set up the vendor.

See [Setting Up Recruiting Vendors](#).

2. Set up a recruitment source and link the vendor to the source.

The system determines how to process the resumes based on the settings that you specify for the recruitment source on the Vendor page in the Source Setup (HRS\_SOURCE\_SETUP) component. For example, the system checks the Vendor page for the source from which it receives a resume to determine which status to assign to the resume.

When you set up contacts for the source, you can specify which contact to use as the proxy. If you do not specify a contact to use as a proxy, the contact setup is used only for informational purposes.

See [Setting Up Recruitment Sources](#).

## Apply Online

Internal and external applicants can use PeopleSoft Candidate Gateway to apply for job openings online.

See “Applying for Jobs” (PeopleSoft Candidate Gateway) and “Using Fluid Candidate Gateway to Apply for Jobs” (PeopleSoft Candidate Gateway).

## Create Applicant Component

Recruiters and hiring managers can enter applicant data manually by using the Create Applicant component.

When recruiters and hiring managers manually enter data for an applicant, they have the option to attach a resume. The data in the resume is not extracted or used to automatically populate fields in the Create Applicant component. However, the creation of these applicants is tracked in the Manage Resumes component.

See [Entering Applicant Data](#).

## Understanding the Resume Extraction Process

Resume extractors extract data from applicant resumes and move the data into Recruiting Solutions tables. Organizations can use multiple resume extractors. For example, you can use a different resume extractor for each country in the organization, or you can use different resume extractors for each recruitment source from which you receive resumes.

The resume extractor that the system selects to use depends on the resume extractor that you specify for a recruitment source, a site, or the extractor that you specify when you run the Resume Load Process or run an extraction from the Manage Resumes (HRS\_AL\_LOG) component. If an applicant attaches their resume to their online application in Candidate Gateway, the system uses the resume extractor that is specified on the Site - Setup Site page for that online application site. If the resume comes from a specific recruitment source; for example, a recruiting agency, the system uses the resume extractor that you specified in the Source Setup component when you set up the recruitment source. When you load resumes by using the Resume Load Process, you select which extractor to use when you run the process.

Resume extractors extract data from an applicant's resume. Not all extractors extract the same data. PeopleSoft software supports the following data from the extractors:

- Contact information: applicant name, home address, telephone numbers, and email address.
- Prior work experience.
- Secondary education.
- Qualifications including licenses and certificates, languages, memberships, honors and awards, and competencies.
- Referrals.
- Full resume text.

Upon successful extraction, the system creates a record for the applicant in the Manage Applicant component, and populates fields in the Manage Applicant component for the applicant. The system also assigns the applicant an applicant ID, a status, a resume name, adds the original resume as an attachment, and associates any job openings that might be applicable. If the applicant attaches a resume when they apply online through Candidate Gateway, the resume extractor populates fields in the applicant's online application and referrals. Of course, this presumes that the extractor actually extracted this data.

---

**Note:** The resume extraction process isn't required for applicants to apply for job openings online by using Candidate Gateway.

---

This process flow shows the resume extraction process starting with receipt of an unstructured resume and ending when the results of the successful or failed extraction are saved to the resume management tables in PeopleSoft Recruiting Solutions.

This diagram illustrates the resume extraction process.

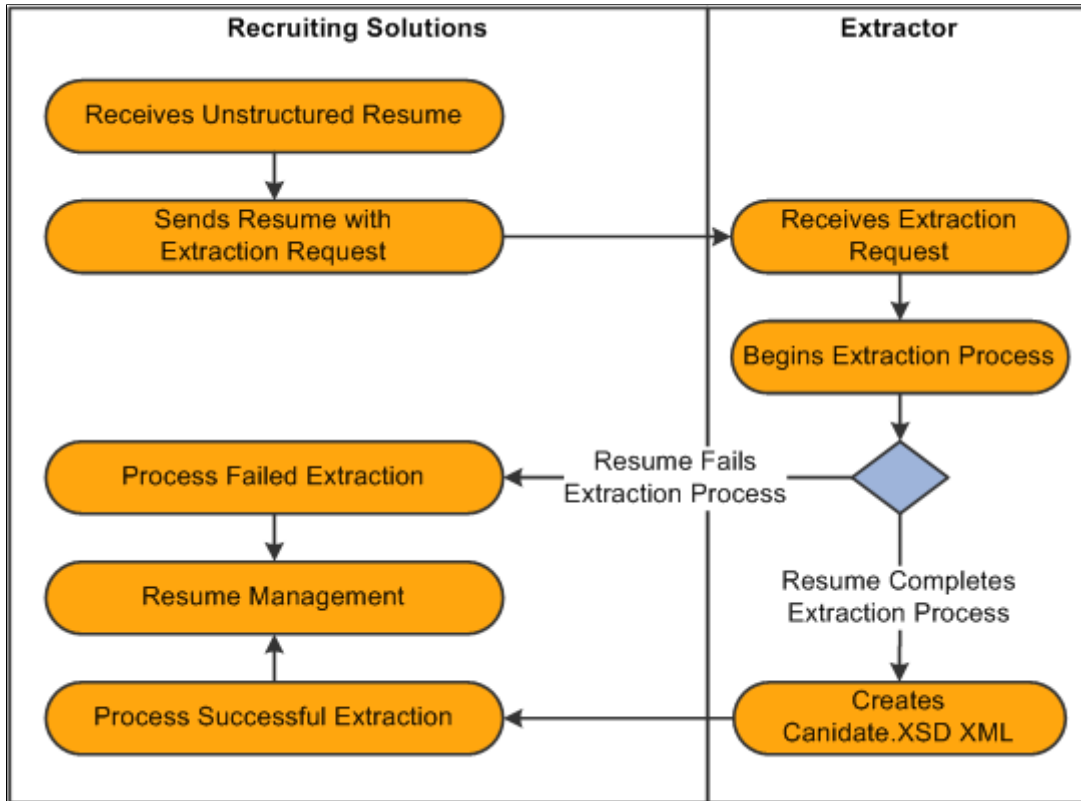

## Understanding Resume Statuses

The system assigns a status, or resolution state, to each resume that it receives. For resumes from recruitment sources that are a Vendor type, the system uses the settings that you define on the Vendor page in the Source Setup component to determine which status to assign to the resume. For the Resume Load Process, the system uses the run parameters that you set up to determine what statuses to assign.

The resume status of a resume is different than the extraction status of the resume. The extraction status of a resume can be either Success or Fail. In general, a resume that fails an extraction process is automatically set to either a Rejected or Unresolved resume status, and resumes that are successfully extracted are set to either a Success or Draft resume status, depending on the business rules that you set up for the recruitment source or the parameters that you select when you run the Resume Load Process.

When the system receives a resume through OIF, the resume extraction process might not be involved. However, the resume status is still applicable. For example, if the system receives a Candidate-XML message directly from a recruiting agency through OIF that is already parsed (extracted), the system does not send it to a resume extractor. However, the system does run the resume through the autoscreening rules that an organization sets up for the recruitment source.

This table describes resume statuses:

<b>Resume Status</b>	<b>Description</b>	<b>Default Applicant Status</b>
Awaiting Resolution	Indicates that the resume is in the database but has not yet been processed through a resume extractor.	Not applicable. Applicant data is not created until the resume is extracted.
Unresolved	Indicates that the resume requires an administrator's attention to move the resume into a Rejected or a Success resume status. Resumes in the Unresolved state can be reprocessed through an extractor, the associated applicant data for these resumes can be manually modified, and then the administrator can set the resume to a Success or Reject status.	Queued
Rejected	Indicates that the system rejected the resume and has set the associated applicant's status to Inactive if the system created an applicant. A resume can be rejected for several reasons. PeopleSoft software supports two types of automatic rejection. First, resumes that are not successfully extracted can automatically be set to the Rejected status. Second, the autoscreening setup for the recruitment source can determine that a resume/applicant fails the Rejected status autoscreening definition and automatically set the resume status to Rejected. Finally, a user can manually set the resume status to Rejected from the Manage Resumes component.	Inactive
Draft	Indicates that the resume requires the associated applicant's attention to move the resume into a Success state. The associated applicant's status is set to Queued. Resumes in the Draft state can be reprocessed through an extractor, the associated applicant data for these resumes can be manually modified, and then the administrator can set the resume to a Success or Reject status. Assigning a Draft status typically requires that the applicant validate their extracted resume data via the online application pages in Candidate Gateway. When the applicant submits the corresponding resume online, the status is updated to Success. If applicants do not validate their resume data, the resume stays in Draft status unless an administrator intervenes.	Queued

<i>Resume Status</i>	<i>Description</i>	<i>Default Applicant Status</i>
Success	<p>Indicates that the resume is successfully extracted and the resume's associated applicant has been set to Active and is ready to continue through the recruitment business processes.</p> <p>When an applicant uses the resume extraction process through Candidate Gateway when they apply for jobs online, the resume status for that resume defaults to Success.</p>	Active

See [Recruitment Sources - Vendor Page](#).

## Loading Resumes

This topic provides an overview of the Resume Load Process, lists prerequisites, and discusses how to load resumes.

### Page Used to Load Resumes

<i>Page Name</i>	<i>Definition Name</i>	<i>Usage</i>
<a href="#">Load Resume - Prepare Load Parameters Page</a>	HRS_RESLOAD	Load resumes.

## Understanding the Resume Load Process (HRS\_RESLOAD)

The Resume Load Process enables organizations to load resumes that it receives in electronic formats. The electronic formats that the system can accept are limited only by the resume extractor that you select to use for the process. You can also use the Resume Load Process to upload paper resumes that you receive, after you transform the paper resumes into an electronic format.

When you set up the process you can specify the resume extractor that you want the system to use, parameters for the resume extractor, the site ID to which you want to redirect applicants, the source to which you want to associate resumes, the statuses that you want to assign to the resumes upon a failed or successful extraction, and the job openings that you want to associate to the applicants. You must browse for and upload the resumes that you want to use in the process. You can upload individual resume documents, or you can upload a zip file that contains multiple resumes. You can also link an applicant to multiple job openings.

**Note:** PeopleSoft recommends that you use the Resume Load Process to link only new applicants to job openings. When this process is run for existing applicants it creates duplicates in the system. To link an existing applicant to a job opening, see [Link Applicant to Job Opening](#).

When you run the process, the system sends the resumes to the resume extractor to parse. After the Resume Load Process completes, you can use the Manage Resumes component to view the status of each of the resumes.

See [Managing Resumes](#).

This diagram shows the Resume Load Process from the time a recruiting administrator gathers resumes in electronic form and ending when the results of the successful or failed extraction are saved to the resume management tables in PeopleSoft Recruiting Solutions.

This diagram illustrates the Resume Load process for loading electronic resumes into resume management tables

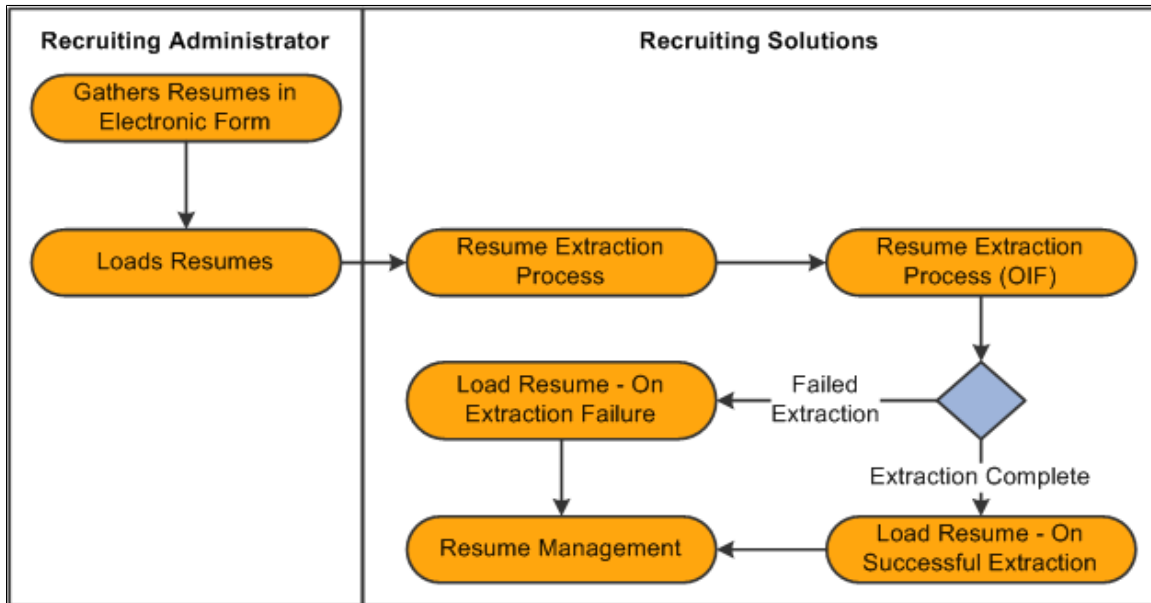

## Prerequisites

Before you can load resumes using the Resume Load Process, you must:

- Set up resume extractor vendors.  
See [link to resume extractor vendor setup in TAM](#)
- Set up site IDs.  
See [“Setting Up Sites” \(PeopleSoft Candidate Gateway\)](#).
- Set up sources and subsources if you want to associate the resumes with a source.  
See [Setting Up Recruitment Sources](#).
- Create job openings if you want to associate applicants with a job opening.  
See [Creating Job Openings](#).

## Load Resume - Prepare Load Parameters Page

Use the Load Resume - Prepare Load Parameters page (HRS\_RESLOAD) to load resumes.

Navigation:

**Recruiting > Administration > Load Resume**

This example illustrates the Load Resume - Prepare Load Parameters page (1 of 2).

### Load Resume

#### Prepare Load Parameters

---

**Load Parameters**

**Basic Information**

\*Resume Load Description  3

Resume Load Status In Preparation

Comments

Extractor

Site ID

Country

Language

\*On Successful Extraction

\*On Extraction Failure

Run Control ID Process Monitor

This example illustrates the Load Resume - Prepare Load Parameters (2 of 2).

**Resume Source**

<b>Source</b>	<b>SubSource</b>			
<input style="width: 95%;" type="text"/>	<input style="width: 95%;" type="text"/>	<input type="button" value="+"/>	<input type="button" value="-"/>	

**Job Openings** Personalize | Find |

First  1 of 1  Last

<b>Job Opening ID</b>	<b>Posting Title</b>			
<input style="width: 95%;" type="text"/>	<input style="width: 95%;" type="text"/>	<input type="button" value="🔍"/>	<input type="button" value="+"/>	<input type="button" value="-"/>

**Resumes**

<b>Resumes</b>	<b>Status</b>		
Attached File	Awaiting Load	<input type="button" value="-"/>	



## Basic Information

Use this group box to specify basic load parameters for the Resume Load Process. The system remembers the settings that you specify in this group and uses the settings for the next process, except for the value in the **Resume Load Description** field, which is dynamic, and the **Comments** field. You can change the defaulted load parameters each time that you run process.

<b>Field or Control</b>	<b>Description</b>
<b>Resume Load Description</b>	The system populates this field with the user ID of the person logged in to the system along with the current date and time. You can edit the description if needed.
<b>Resume Load Status</b>	Displays the status of the Resume Load Process. Values are:  <i>In Preparation:</i> Indicates that the process has not started. The system displays this status until you click the <b>Load Resumes</b> button.  <i>Load in Progress:</i> Indicates that the process is in progress. The system displays this status after you click the <b>Load Resumes</b> button and before the process completes.  <i>Loaded:</i> Indicates that the process is complete. The system displays this status after all resumes are processed.
<b>Comments</b>	Enter comments. These comments appear only on this page and are used only for informational purposes.
<b>Extractor</b>	Select the resume extractor that you want the system to use. Only active vendors from the Resume Extractor transaction group appear in this prompt. Define vendors by using the Vendor Setup (HRS_VENDOR_SETUP) component.
<b>Site ID</b>	Select a site ID where you want to redirect applicants. Define sites on the Site - Site Setup page.
<b>Country</b>	Select a country. Some resume extractors require a country to begin the extraction process.
<b>Language</b>	Select the language in which the resumes are written. This is an optional field. Some resume extractors use this language for the extraction process, however, other extractors ignore this field.

<b>Field or Control</b>	<b>Description</b>
<b>On Successful Extraction</b>	<p>Select the status that you want the system to assign to the resume upon successful extraction. You can view the status of resumes by using the Manage Resumes (HRS_AL_LOG) component. Values are:</p> <p><i>Set to Draft:</i> Select to set the status of successfully extracted resumes to Draft.</p> <p><i>Set to Success:</i> Select to set the status of successfully extracted resumes to Success.</p>
<b>On Extraction Failure</b>	<p>Select the status that you want the system to assign to the resume upon a failed extraction. You can view the status of resumes by using the Manage Resumes component. Values are:</p> <p><i>Reject Resume:</i> Select to set the status of resumes that failed to extract to Rejected.</p> <p><i>Set to Unresolved:</i> Select to set the status of resumes that failed to extract to Unresolved.</p>
<b>Run Control ID</b>	Displays the run control ID. The system generates the run control ID after you click the <b>Load Resumes</b> button.
<b>Process Monitor</b>	Click to access the Process List page, where you can monitor the process request.

## Resume Source

<b>Field or Control</b>	<b>Description</b>
<b>Source and SubSource</b>	<p>Select a source and subsource to assign to the resumes. The values that appear in the <b>Source</b> field are active recruitment sources with a source type of Marketing. After you select a source, the system populates the <b>SubSource</b> field with the subsources for that source. Define sources and subsources by using the Source Setup (HRS_SOURCE_SETUP) component.</p>

## Job Openings

<i>Field or Control</i>	<i>Description</i>
<b>Job Opening ID and Posting Title</b>	Select a job opening ID to link the applicants to the job opening. When you select a job opening, the system populates the <b>Posting Title</b> field automatically. If you specify more than one job opening, the system creates one application, but links the applicants to all job openings. When you link a job opening to an applicant, the disposition is set to Applied.

## Resumes

Use this group box to view the resumes that you have uploaded.

<i>Field or Control</i>	<i>Description</i>
<b>Resumes</b>	Displays the file name for each resume that you have uploaded as a link. Click the file name link to open and view the resume in a separate browser window. To successfully open the file, you must have the application that the resume was created in installed on your computer.
<b>Status</b>	<p>Displays the status of each resume. Values are: <i>Awaiting Load</i>, <i>Draft</i>, <i>Success</i>, <i>Rejected</i>, and <i>Unresolved</i>. <i>Awaiting Load</i> appears for all resumes until the Resume Load Resume process completes. When the process completes the system assigns a status to each resume based on the status values that you specify in the <b>On Successful Extraction</b> and <b>On Extraction Failure</b> fields.</p> <p>Click a status link to access the Resume Management - Select Resume page, where you can view details for that resume. The statuses appear as links only after the process completes.</p>

## Additional Page Elements

<i>Field or Control</i>	<i>Description</i>
<b>Add Multiple Resumes</b>	Click to browse for a zip file and upload all resumes from that zip file. You must have network access to where the zip file is located. The system removes this button from the page after you initiate the Resume Load Process.

<b>Field or Control</b>	<b>Description</b>
<b>Add Resume</b>	Click to browse for and select a single file to upload. The system removes this button from the page after the process completes.
<b>Load Resumes</b>	Click to run the Load Resume process. After you click this button, all options on this page become display-only.
<b>View Log for All Resumes</b>	Click to access the Resume Management - Select Resume page, where you can view details for all resumes that were processed. This link appears only after the Load Resume process completes.

---

## Managing Resumes

This topic provides an overview of Resume Management, lists a prerequisite, and discusses how to manage resumes.

### Pages Used to Manage Resumes

<b>Page Name</b>	<b>Definition Name</b>	<b>Usage</b>
<a href="#">Manage Resumes - Select Resume Page</a>	HRS_AL_LOG	Manage resumes.
<a href="#">Resume Management Details Page</a>	HRS_AL_LOG_DETAILS	View details for resumes.
View Candidate XML	HRS_CANDIDATE_XML	View the final output of the resume extraction.

## Understanding Resume Management

Use the Manage Resumes (HRS\_AL\_LOG) component to view details for all resumes that the system receives via any channel. For each resume, you can view its source, channel, and status.

### Prerequisite

Before you can manage resumes, the system must receive resumes from one of the valid channels.

See [Understanding Resume Management](#).

## Manage Resumes - Select Resume Page

Use the Manage Resumes - Select Resume page (HRS\_AL\_LOG) to manage resumes.

Navigation:

**Recruiting > Administration > Manage Resumes**

This example illustrates the Manage Resumes - Select Resume page.

### Manage Resumes

#### Select Resume

**Search Criteria**

First Name

Last Name

Email Address

Source

Channel

Resolution State

\*Date Type

Start Date

End Date

**Search Results** Personalize | Find | View All |  |

First  1-2 of 2  Last

	Name	Source	Channel	Resolution State	Details
<input type="checkbox"/>	Maharroof Steyn	Special Promotions	Apply Online	Success	<a href="#">Details</a>
<input type="checkbox"/>	Kevin Beyley	Special Promotions	Apply Online	Success	<a href="#">Details</a>

Select All Deselect All

Action

### Search Criteria

Use this group box to enter search criteria. Click **Search** to display the **Search Results** group box.

<b>Field or Control</b>	<b>Description</b>
<b>First Name and Last Name</b>	Enter the partial or full first or last name of the applicant.
<b>Email Address</b>	Enter the email address of the applicant.
<b>Source</b>	Select a source. All sources that you set up by using the Source Setup component appear here.
<b>Channel</b>	<p>Select a channel. Values are:</p> <p><i>Apply Online</i>: Displays resumes that applicants attach when they apply for job openings online by using Candidate Gateway</p> <p><i>Email</i>: Displays resumes that the system receives through an email account.</p> <p><i>Integration Framework</i>: Displays resumes that the system receives through the OIF.</p> <p><i>Load Resume</i>: Displays resumes that you uploaded through the Resume Load Process.</p> <p><i>Manage Entry</i>: Displays resumes that you attach to applicants that you manually enter into the system by using the Create Applicant component.</p> <p><i>Refer a Friend</i>: This functionality is not available at this time.</p>
<b>Resolution State</b>	Select a resume status. Values are: <i>Awaiting Resolution, Draft, Rejected, Success, Unresolved with Errors</i> .
<b>Date Type, Start Date, and End Date</b>	<p>Select a date type and enter a start and end date to view resumes between those dates that meet the date type criteria.</p> <p>Date type options include:</p> <p><i>Notifications</i>: Select to search based on the date a notification was sent.</p> <p><i>Original Submission</i>: Select to search for resumes based on the date that the resume was originally submitted.</p> <p><i>Resolution Updates</i>: Select to search for resumes based on the date that the resolution was updated.</p>

## Search Results

Use this group box to view the resumes that meet the search criteria. For each resume the system displays the applicant's name, the source, channel, and resolution state (resume status).

<i>Field or Control</i>	<i>Description</i>
<b>Details</b>	Click to access the Resume Management Details page, where you can view details for the resume.

## Additional Page Elements

<i>Field or Control</i>	<i>Description</i>
<b>Action and Go</b>	<p>Select an action and click <b>Go</b>. The system performs the action for all applicants that you select. For each action, the system logs a new row in the appropriate group box on the Resume Management Details page. Values are:</p> <ul style="list-style-type: none"> <li> <p><i>Reject</i>: The system updates the status to Reject.</p> <p>Use this status for resumes that the resume extractor can't extract or work with.</p> </li> <li> <p><i>Reject &amp; Notify</i>: The system updates the status to Reject and sends a notification (HRS_HROI_REJECT) to all applicants.</p> <p>Use the message catalog to modify the message text.</p> </li> <li> <p><i>Send Notifications</i>: The system sends a notification (HRS_HROI_DRAFT, HRS_HROI_REJECT, HRS_HROI_SUCCESS, or HRS_HROI_UNRESOLVED) to the applicant.</p> <p>The notification that the system sends depends on the status of the resume. If the resume is from a specific source, the system looks at the setup in the <b>Notifications</b> group box on the Vendor page to determine which notification to send. Use the message catalog to modify the message text. When the system sends the notification, it also adds a row to the <b>Notification Log</b> group box on the Resume Management Details page that describes details about the notification.</p> </li> <li> <p><i>View Applicants</i>: Select to access the Manage Applicant page for the selected applicants.</p> </li> </ul>

## Resume Management Details Page

Use the Resume Management Details page (HRS\_AL\_LOG\_DETAILS) to view details for resumes.

Navigation:

Click the **Details** link for an applicant on the Manage Resumes - Select Resume page.

This example illustrates the Resume Management Details page.

### Resume Management Details

Name [Maharoorf Steyn](#)

Email [HCMGENUser1@ap6023fems.us.oracle.com](mailto:HCMGENUser1@ap6023fems.us.oracle.com)

Vendor Source Channel [Apply Online](#)

Resume File [None](#)

Source History		Personalize   Find		First  1 of 1  Last
Marketing Source	Subsource	Last Updated	Last Updated By	
Special Promotions	Promo 1	02/10/09 2:48PM	SAMPLE	

Resolution History				
Channel	Site ID	Resolution State	Resolution Description	Last Updated
Apply Online	Default Site	Success		02/10/2009 2:48PM

Action

[Return](#)

<i><b>Field or Control</b></i>	<i><b>Description</b></i>
<b>Name</b>	Click the applicant's name link to access the Manage Applicant page for that applicant.
<b>Source</b>	Displays the vendor recruitment source. The system populates this field only when a resume channel is email or OIF.
<b>Resume File</b>	Click the resume file link to open and view the resume in a separate browser window. To successfully open the file, you must have the application that the resume was created in installed on your computer.

### Extraction History

Use this group box to view resume extraction history details, included the resume extractor vendor, the status of the extraction, and the time in which the extraction took place. This group box appears on this page only if the resume has been extracted.



<i>Field or Control</i>	<i>Description</i>
<b>Integration Log</b>	Click to access the <a href="#">Integration Log Page</a> , where you can view all transactions for the extraction.
<b>Candidate XML</b>	Click to access the View Candidate XML page, where you can view the final output of the resume extraction.

## Notification Log

Use this group box to view the notifications that the system sends to the applicant. Each time you send a notification to the applicant, the system adds a new row that describes which template was used and to whom the notification was sent. This group box does not appear on the page unless the system has sent a notification to the applicant.

## Source History

Use this grid to view details about the marketing recruitment sources and subsources that are associated to this resume.

## Resolution History

Use this grid to view resolution history for the resume.

## Additional Page Elements

<i>Field or Control</i>	<i>Description</i>
<b>Action and Go</b>	<p>Select an action and click <b>Go</b>. Values are:</p> <p><i>Edit Applicant:</i> Select to access the Manage Applicant page, where you can view and modify the applicant's information.</p> <p><i>Refresh:</i> Select to refresh the page.</p> <p><i>Send Notification:</i> The system sends a notification (HRS_HROI_DRAFT, HRS_HROI_REJECT, HRS_HROI_SUCCESS, or HRS_HROI_UNRESOLVED) to the applicant. The notification that the system sends depends on the status of the resume. If the resume is from a specific source, the system looks at the setup in the <b>Notifications</b> group box on the Vendor page to determine which notification to send. Use the message catalog to modify the message text. When the system sends the notification, it also adds a row to the <b>Notification Log</b> group box that describes details about the notification.</p>



# Managing Employee Referral Programs

---

## Understanding the Employee Referral Program Process

Setting up and administering the employee referral program process includes the following tasks:

1. Set up employee referral programs.
2. Administer hot jobs.
3. Process employee referrals.
4. Review and override results.
5. Approve and pay awards.

The following diagram illustrates the task flow for setting up and administering employee referral programs.

This diagram illustrates the process for setting up and administering employee referral programs

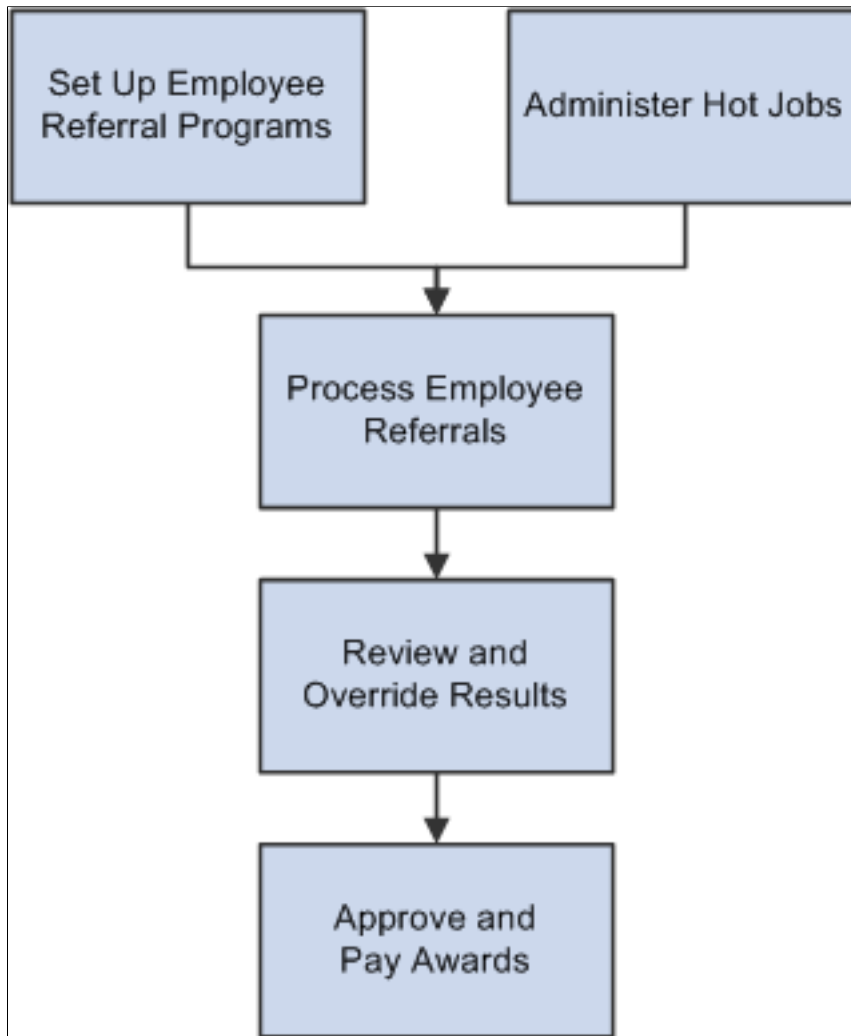

---

## Understanding How Referrals are Submitted

The two referral methods are:

- The applicant identifies the referring employee when submitting an application.
  - Applicants can submit referral information in the Referrals section of the online job application.
  - Recruiters who manually add applications to the system can enter referral source information on the [Application Details Page](#).
- The employee initiates the referral using the Refer a Friend option in Candidate Gateway.  
See “Entering Referrals” (PeopleSoft Candidate Gateway).

## Applicant-Provided Referral Information

When applicants use Candidate Gateway to apply for jobs, they use the Referrals section of the application to indicate how they learned about the job. (The [Template Sections Page](#) in the resume template controls whether the Referrals section is included in the application.)

When the recruitment source that the applicant selects in the **How did you learn of the job?** field is a recruitment source with source type Employee, the Referrals section displays the **Referral Name** and **Email Address** fields to collect additional information about the employee referral. The **Member of Your Family** check box also appears, as this information can be relevant to award processing for an employee referral program.

When the application is submitted, the system sends a notification to the referral email address provided by the applicant. The notification requests confirmation of the referral. It includes a link to the Confirm Referral - Access page, and provides a referral ID (called the “track ID”) and a password that the employee uses to access the referral to confirm it. The email also contains a link to the Review Referral page, where the employee can track the status of the referral after confirming it.

An employee's failure to confirm the referral does not affect the recruitment process for the applicant. However, if the employee does not confirm an applicant-provided referral, the employee is not eligible to receive award payments for the referral.

See “Confirming Referrals” (PeopleSoft Candidate Gateway).

## Employee-Provided Referrals

When employees refer a friend through employee self-service, the system creates an active applicant record for the friend, sets the applicant's disposition to Draft, and sets the referral source to employee. The application remains in Draft status until the applicant accesses it and submits it. The employee who is referring the applicant cannot submit the application on behalf of the applicant.

When the employee submits the referral, the system sends an email to the friend using the email address that the employee provided. The email includes a link that enables the friend to access Candidate Gateway. When the applicant registers or signs in after using that link, the Candidate Gateway account is associated with the draft application that the referral process created. The applicant can review the job posting and, if interested, complete and submit the application.

The employee who submitted the original referral is permanently recognized as the referring employee for the application that the referral process created. If the online application includes the Referrals section, the “**How did you learn of the job**” field is set to show that this is an employee referral, the employee's name and email address are entered in the appropriate fields, and these fields are read-only.

The referring employee receives a confirmation email when the applicant submits the application. Employees can review the eligibility and payment status of the referrals that they submit using the “Review Referral Page” (PeopleSoft Candidate Gateway).

See “Entering Referrals” (PeopleSoft Candidate Gateway).

---

## Setting Up Employee Referral Programs

This topic provides an overview of employee referral program setup steps and discusses how to define employee referral programs, including eligibility rules and awards.

## Pages Used to Set Up Employee Referral Programs

<i>Page Name</i>	<i>Definition Name</i>	<i>Usage</i>
<u>Employee Eligibility Rules Page</u>	HRS_RULE_DEF	Name employee eligibility rules.
<u>Referral Eligibility Rules - Rule SQL Page</u>	HRS_RULE_SQL	Create SQL statements for employee eligibility rules.
View SQL Page	HRS_VW_SQL	View a SQL statement that the system generates from information that you enter to define an eligibility rule, an award rule, or hot job selection.
<u>Award Category Rules Page</u>	HRS_RULE_DEF	Name award category rules.
<u>Referral Category Rules - Rule SQL Page</u>	HRS_RULE_SQL	Create SQL statements for award category rules.
<u>Award Schedule Page</u>	HRS_RULE_AWD_SCH	Define award schedules.
<u>Employee Referral Programs Page</u>	HRS_REF_PGM_PG	Define employee referral programs.
<u>Employee Referral Program - Criteria Page</u>	HRS_REF_PGM_CRT	Define additional criteria that are not covered by employee eligibility or award category rules.
<u>Employee Referral Program - Rules Page</u>	HRS_REF_PGM_RUL	Select employee eligibility and award category rules that are in effect for the program.
Employee Eligibility Rule Page	HRS_RULE_ELIG_SP	View the employee eligibility rule description from the context of the Employee Referral Program - Rules page. The eligibility rule description comes from the <b>Long Description</b> field on the Employee Eligibility Rules page.
Award Category Rule Page	HRS_RULE_AWD_SP	View the award category rule description from the context of the Employee Referral Program – Rules page. The award category rule description comes from the <b>Long Description</b> field on the Award Category Rules page.

## Understanding How to Set Up Employee Referral Programs

The following diagram shows how to set up employee referral programs by defining employee eligibility rules and award category rules, using those rules to create referral programs, and linking the programs to recruitment templates:

This diagram illustrates the process for setting up employee referral programs and linking the programs to recruitment templates

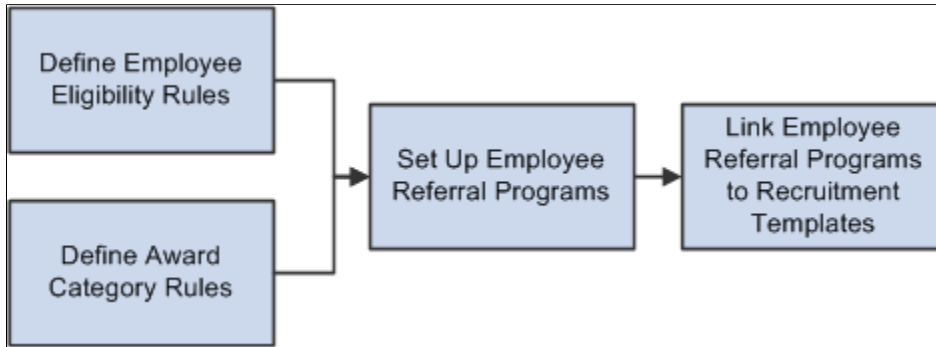

To set up employee referral programs:

1. Define employee eligibility rules using the Referral Eligibility Rules (HRS\_RULE\_ELIG) component.

Employee eligibility rules define the conditions under which an employee is eligible for award payment under the employee referral program. For example, you might want to limit eligibility to employees who work in a particular geographic area or type of job. You might want to exclude employees in certain departments or locations. You can create a rule that combines a number of criteria to determine employee eligibility.

To define employee eligibility rules:

- a. Name and describe the employee eligibility rule on the Employee Eligibility Rules page.
- b. Create SQL statements for the employee eligibility rule on the Referral Eligibility Rules - Rule SQL page.

2. Define award category rules using the Award Category Rules (HRS\_RULE\_AWD) component.

When you define the award category rules, you're defining the job openings that qualify for awards in the category and the amounts and timing of awards for the category. You can create any number of award categories, each with an award schedule. The job opening that the applicant is hired into determines the award category for the referring employee's award.

You should define categories so that each job opening (for which you want to have an employee referral program award) falls into only one category. Job openings that do not fall into any category cannot be processed for employee referrals.

To define award category rules:

- a. Name and describe the award category rule on the Award Category Rules page.

- b. Create SQL statements for the employee eligibility rule on the Referral Category Rules - Rule SQL page.
  - c. Define the amounts, timing, and earnings code for the rule on the Award Schedule page.
3. Define employee referral programs using the Employee Referral Program (HRS\_REF\_PGM) component.

To define employee referral programs:

- a. Name the employee referral programs.
  - b. Set up additional criteria.
  - c. Link employee eligibility and award category rules.
4. Associate an employee referral program with a recruitment template using the Recruitment Template (HRS\_RCTR\_TMPL) component.

By linking a referral program to a recruitment template, the system will automatically associate a referral program with a job opening when the job opening is created. In turn, the system uses this employee referral program's rules to evaluate eligibility and pay awards for the job opening.

## Employee Eligibility Rules Page

Use the Employee Eligibility Rules page (HRS\_RULE\_DEF) to name and describe an employee eligibility rule.

Navigation:

**Set Up HCM > Product Related > Recruiting > Recruitment Sources > Referral Eligibility Rules > Employee Eligibility Rules**

This example illustrates the Employee Eligibility Rules page.

The screenshot shows the 'Employee Eligibility Rules' page with the following details:

- Employee Eligibility Rules** | **Rule SQL**
- Rule ID** KU\_EE\_HD02
- \*Description** US ERP - Hir Dt 02
- \*Short Description** US ERP-H02
- Long Description** US ERP - Hire Date Rule 02  
 Employees based in the US who are not in the HR dept. and are either
  1. Active as of the referral date
  - OR -
  2. employee on leave for maternaty or millitary.



<b>Field or Control</b>	<b>Description</b>
<b>Long Description</b>	Enter a description of the employee eligibility rule. This description appears on the Employee Eligibility Rule page in the Employee Referral Program component.

## Referral Eligibility Rules - Rule SQL Page

Use the Referral Eligibility Rules - Rule SQL page (HRS\_RULE\_SQL) to create SQL statements for employee eligibility rules.

Navigation:

**Set Up HCM > Product Related > Recruiting > Recruitment Sources > Referral Eligibility Rules > Rule SQL**

This example illustrates the Referral Eligibility Rules - Rule SQL page.

<b>Field or Control</b>	<b>Description</b>
<b>Open ( and Close )</b> (open and close parentheses)	Use these fields to add parentheses around clauses in your selection criteria. The drop-down list box offers separate values with one to five parentheses so that you can create nested groups of clauses.  <b>Important!</b> Be sure to properly close all parentheses.
<b>Record and Field</b>	Select the record and field that hold the data to be evaluated.  Select one of these records: <ul style="list-style-type: none"> <li><i>HRS_EMPLOYMT_I</i> contains four employment-related fields: hire date, last date worked, rehire date, and termination date.</li> <li><i>HRS_JOB_I2</i> contains several job-related fields, including (but not limited to) action, action reason, business unit, company, department, employee type, pay group, regulatory region, full time/part time status, regular/temporary status, and standard hours.</li> </ul>

<b>Field or Control</b>	<b>Description</b>
<b>Operator</b>	<p>Enter the operator to indicate how you are going to evaluate the data in the selected field. Select from these options:</p> <ul style="list-style-type: none"> <li>• <i>Equal To</i></li> <li>• <i>Greater Than</i></li> <li>• <i>Greater Than or Equal to</i></li> <li>• <i>LIKE</i></li> <li>• <i>Less Than</i></li> <li>• <i>Less Than or Equal To</i></li> <li>• <i>Not Equal To</i></li> </ul>
<b>Set ID</b>	<p>If setID is a key for the record and field that you selected, select the setID for the value that the clause evaluates.</p> <p>This field does not appear if setID is not a key.</p>
<b>Action</b>	<p>If you are evaluating data in the Action/Reason field (that is, you selected <i>HRS_JOB_I2</i> as the record and <i>ACTION_REASON</i> as the field), use this field to select an action.</p>
<b>Value</b>	<p>Enter a value that corresponds with the record, field, and operand that you selected. You can enter either a static string or select a value from a list of valid values for the field. When selecting from a list, you are limited to values from the setID, if any, that you entered.</p> <p>If you are evaluating the Action/Reason field, select a reason that is associated with the action you selected.</p>
<b>Boolean</b>	<p>For every grid row except the last one, select <i>AND</i> or <i>OR</i> to link the clauses in the grid.</p>
<b>View SQL</b>	<p>Click to access the View SQL page, where you can view the SQL generated by the values that you entered for this rule definition.</p>

## Award Category Rules Page

Use the Award Category Rules page (HRS\_RULE\_DEF) to name award category rules.

Navigation:

**Set Up HCM > Product Related > Recruiting > Recruitment Sources > Referral Category Rules > Award Category Rules**

This example illustrates the Award Category Rules page.

Award Category Rules
Rule SQL
Award Schedule

Rule ID KC\_AWD\_01A

---

\*Description

\*Short Description

Long Description

<i>Field or Control</i>	<i>Description</i>
<b>Long Description</b>	Enter a description of the award category rule. This description appears on the Award Category Rule page in the Employee Referral Program component.

## Referral Category Rules - Rule SQL Page

Use the Referral Category Rules - Rule SQL page (HRS\_RULE\_SQL) to create SQL statements for award category rules.

Navigation:

**Set Up HCM > Product Related > Recruiting > Recruitment Sources > Referral Category Rules > Rule SQL**

This example illustrates the Referral Category Rules - Rule SQL page.

Award Category Rules
Rule SQL
Award Schedule

Rule ID KC\_AWD\_01A      Description Can ERP - Award Category 01A

**Award Selection Criteria**

Open (	Record	*Field Name	*Operator	Set ID	Value	Boolean	Close )		
1	HRS_JOB_I2	REG_REGION	Equal To	CAN		AND		+	-
2	HRS_JOB_I2	DEPTID	Equal To	SHAR	22000	AND		+	-

[View SQL](#)

The steps that you use to construct a rule are the same as the steps that you use on the Referral Eligibility Rules - Rule SQL page.

For award category rules, the records are HRS\_EMPLOYMT\_I, HRS\_JOB\_I2, HRS\_JO\_I, or HRS\_PSTBTH\_I.

See [Referral Eligibility Rules - Rule SQL Page](#).

## Award Schedule Page

Use the Award Schedule page (HRS\_RULE\_AWD\_SCH) to define award schedules.

Navigation:

**Set Up HCM > Product Related > Recruiting > Recruitment Sources > Referral Category Rules > Award Schedule**

This example illustrates the Award Schedule page.

The screenshot shows the 'Award Schedule' tab selected. The rule ID is 'KC\_AWD\_01A' and the description is 'Can ERP - Award Category 01A'. The currency code is set to 'Canadian Dollar' and the award total is '2,000.00'. Below this, there is a table with the following data:

*Earnings Code	*Duration	*Type	*Award Value	Description	Gross-Up
AWD	6	Months	2,000.00	Can Sales Job Req Award	<input type="checkbox"/>

<b>Field or Control</b>	<b>Description</b>
<b>Currency Code</b>	Select the currency that is used to define awards in this category. Valid values are <i>Canadian Dollar</i> and <i>US Dollar</i> . You can override the currency on the Referral Award Details page.  <b>Important!</b> Employee referral program rewards are paid to employees in the currency that corresponds to where the employee is located. Recruiting Solutions and PeopleSoft Payroll for North America do not provide currency conversion. For example, if you define the award as 100.00 CAD, but the employee that receives the award is normally paid in US dollars, Payroll for North America will pay an award of 100.00 USD to the employee.
<b>Award Total</b>	Displays the total of all awards in the schedule. Click the refresh button to update the award total.
<b>Earnings Code</b>	If you use the delivered integration with Payroll for North America to pay employee referral award, you must select the earnings code associated with the award. This field appears only if Payroll for North America is installed. Define earnings codes by using the Earnings Table (EARNINGS_TABLE) component.

<b>Field or Control</b>	<b>Description</b>
<b>Duration and Type</b>	Enter the time period that the referring employee must wait until the award is payable. You can enter the time period in days, months, or years. To calculate the date on which the reward is payable, the system begins with the date that the applicant is hired or rehired and adds the duration time period. This is referred to as the award date and is the date on which the duration requirement is fulfilled; it is not necessarily the date on which the award is paid. If you use the delivered integration with Payroll for North America to pay employee referral award, the system will not send award information before the award date.
<b>Award Value</b>	Enter the amount of a cash award or the value of a noncash award.
<b>Gross-Up</b>	Select this check box if the award should be grossed up.

## Employee Referral Programs Page

Use the Employee Referral Programs page (HRS\_REF\_PGM\_PG) to define employee referral programs.

Navigation:

**Set Up HCM > Product Related > Recruiting > Recruitment Sources > Employee Referral Program**

This example illustrates the Employee Referral Programs page.

The screenshot shows the 'Employee Referral Programs' page with tabs for 'Criteria' and 'Rules'. The main content area displays 'Referral Program ID KC\_ERP\_01' and 'General Program Information'. Fields include:
 

- \*Effective Date: 01/01/1999
- \*Description: ERP for Candian-based jobs
- Status: Active
- Short Desc: Can ERP 01
- Checkboxes: Require Approval for Payment, Separate Check, Allow Dups to Exceed Original (all unchecked).
- Use Program As Of: Referral Date
- Long Description: Employee Referral Program (ERP) for Canadian-based job requisitions.

<b>Field or Control</b>	<b>Description</b>
<b>Effective Date</b>	Enter an effective date. The system uses the effective date with the <b>Use Program As Of</b> field to determine the rules that are in effect for a referral.

<b>Field or Control</b>	<b>Description</b>
<b>Require Approval for Payment</b>	Select this check box to require approval for an award before the award is sent to the payroll system. Awards that have an Approved status can be submitted for payment. If you select this option, the system assigns a Needs Approval status to an award when the award is created. Users must manually approve the award on the Approve Employee Awards page. If you deselect this check box, awards are automatically given Approved status when they are created.
<b>Separate Check</b>	Select this check box if you want the award paid separately from the employee's regular paycheck. If you are paying awards through Payroll for North America, all grossed-up awards are paid by a separate check.
<b>Allow Dups to Exceed Original</b> (allow duplicates to exceed original)	Select this check box if the total award can exceed the original award amount when an award is split among several referring employees.
<b>Use Program As Of</b>	<p>Select which effective-dated program rules apply to the referral. Valid values are <i>Applicant's Hire Date</i> and <i>Referral Date</i>. The system applies all program rules that are in the effective-dated row that is active as of the <b>Use Program As Of</b> date. For example, an employee referred an applicant on December 1 and that applicant was hired on February 1 of the following year. However, the ERP rules changed on January 1 from \$100 for all successful referrals before January 1 to \$1000 for those on or after January 1. If the Use Program As Of field is set to Referral Date, the employee is entitled to only \$100 since the referral was made before January 1. If the field is set to Applicants Hire Date, the employee is entitled to \$1000 since the applicant was hired after January 1.</p> <hr/> <p><b>Note:</b> This field is only available when a new employee referral program is created. After saving the employee referral program, the value in subsequent effective-dated rows cannot be changed.</p> <hr/>

## Employee Referral Program - Criteria Page

Use the Employee Referral Program - Criteria page (HRS\_REF\_PGM\_CRT) to define additional criteria that are not covered by employee eligibility or award category rules.

Navigation:

**Set Up HCM > Product Related > Recruiting > Recruitment Sources > Employee Referral Program > Criteria**

This example illustrates the Employee Referral Program - Criteria page.

### Limit Referral Life Span To

<b>Field or Control</b>	<b>Description</b>
Limit Interval and Limit Duration	<p>Enter a time limit for how soon after the referral the applicant must be hired. The limit interval can be measured in <i>Months</i>, <i>Years</i>, or <i>Days</i>. The limit duration is the number of months, days, or years.</p> <p>For example, if employees get referral credit for applicants who are hired within two months of the referral, enter <i>Months</i> as the limit interval and <i>2</i> as the limit duration.</p>

### Disqualify Award If

Use this group box to indicate conditions that disqualify the employee from the referral program.

<b>Field or Control</b>	<b>Description</b>
<b>Applicant Reports to Employee</b>	Select this check box to disqualify employees if the applicant reports to them directly or indirectly based on the department tree structure as of the applicant's hire date. If you use this rule, you must set up the department tree structure in PeopleSoft Human Resources.
<b>Employee Exceeds Manager Level</b>	Select a value to disqualify employees above the specified level. The system evaluates employee levels as of the applicant's hire date.  To make all managers ineligible, select <i>All Other Positions</i> .  If you use this rule, you must set up the department tree structure in Human Resources.

### Applicant Criteria

<b>Field or Control</b>	<b>Description</b>
<b>Allow Previous Employees</b>	Select this check box to give referral credit for applicants who are previous employees. If you select this check box, you must complete the termination interval fields in this group box.
<b>Termination Interval, Interval Duration, and Is Prior To</b>	If you allow referral credit for previous employees, use these fields to define how long the applicant must have been away from the organization before being rehired. The system evaluates this criteria based on information that users provide when they refer friends online or information that recruiters enter for an applicant on the applicant data pages. It does not check the organization's historical records.  To allow credit for all rehires, regardless of the length of the break in service lasted, enter 0 in the <b>Interval Duration</b> field.  To set a minimum duration for the break in service, use the <b>Termination Interval</b> field to select <i>Months, Days, or Years</i> , and then enter the number of months, days, or years in the <b>Interval Duration</b> field. Use the <b>Is Prior To</b> field to indicate whether the <i>Applicant's Hire Date</i> or the <i>Referral Date</i> is used as the starting point for the look-back.  For example, if you allow referral credit for rehires only if the rehire was away for your organization at least six months before being referred, enter <i>Months</i> as the termination interval, 6 as the interval duration, and <i>Referral Date</i> as the <b>Is Prior To</b> setting.



<b>Field or Control</b>	<b>Description</b>
<b>Allow Family Member Referrals</b>	Select this check box to allow employees to refer members of their family.

## Employee Referral Program - Rules Page

Use the Employee Referral Program - Rules page (HRS\_REF\_PGM\_RUL) to select employee eligibility and award category rules that are in effect for the program.

Navigation:

**Set Up HCM > Product Related > Recruiting > Recruitment Sources > Employee Referral Program > Rules**

This example illustrates the Employee Referral Program - Rules page.

The screenshot shows the 'Rules' tab for 'Employee Referral Programs'. The main header indicates 'Referral Program ID KC\_ERP\_01'. Below this, there are three main sections:

- Program Rules:** Shows 'Effective Date 01/01/1999' and 'Description ERP for Candian-based jobs'. It includes navigation options like 'Find | View All' and 'First 1 of 1 Last'.
- Employee Eligibility Rules:** A table with columns for '\*When to Apply', '\*Rule ID', 'Description', 'View Description', and 'View Rule'. It lists two rules:
 

*When to Apply	*Rule ID	Description	View Description	View Rule
Applicant's Hire Date	KC_EE_HD	Can ERP - Hir Dt 01	View Description	View Rule
Award Date	KC_EE_AD	Can ERP - Awd Dt 01	View Description	View Rule
- Award Category Rules:** A table with columns for '\*Priority', '\*Rule ID', 'Description', 'View Description', and 'View Rule'. It lists two rules:
 

*Priority	*Rule ID	Description	View Description	View Rule
100	KC_AWD_01	Can ERP - Award Category 01A	View Description	View Rule
200	KC_AWD_02	Can ERP - Award Category 02A	View Description	View Rule

## Employee Eligibility Rules

<b>Field or Control</b>	<b>Description</b>
<b>When to Apply</b>	<p>Select when to apply each employee eligibility rule that you associate with this program. Valid values are <i>Applicant's Hire Date</i>, <i>Award Date</i>, and <i>Referral Date</i>. You can select each of the three values only once for a maximum of three rows.</p> <p>The system uses the rule that you associate with the award date to check eligibility before paying any award in the award category award schedule or in a hot job award schedule.</p> <p>This field enables you to apply different employee eligibility rules at different points in the referral process. For example, you might want to apply strict employee eligibility rules at the time that the applicant is hired, but on the award date, you might only require that the employee have an Active status.</p>
<b>Rule ID and Description</b>	<p>Select the rule that you want to apply. The system populates the <b>Description</b> field automatically. Valid values are the rules that you set up in the Referral Eligibility Rules component.</p>
<b>View Description</b>	<p>Click to access the Employee Eligibility Rule page, where you can view the description that you entered in the <b>Long Description</b> field on the Employee Eligibility Rules page.</p>
<b>View Rule</b>	<p>Click to access the Referral Eligibility Rules component, where you defined the employee eligibility rule. Use your browser's back button to return to the Employee Referral Program - Rules page.</p>

## Award Category Rules

<i>Field or Control</i>	<i>Description</i>
<b>Priority</b>	<p>Enter an integer in this field to tell the system in what order to process the award category rules. The system checks the job opening that the applicant is hired into against the category rules in the priority order. As soon as it finds the job opening in a category, it stops processing that job opening and applies the award schedule for that category.</p> <p>You should make the award category rules mutually exclusive so that a job opening does not fall into multiple categories.</p> <p>The system does contain safeguards against paying an employee in multiple award categories for the same applicant.</p> <p>If a job opening does not fall into any award category, no awards are scheduled or paid.</p>
<b>Rule ID and Description</b>	<p>Select the rule that you want to apply. The system populates the Description field automatically. Valid values are the rules that you set up in the Award Category Rules component. You can assign as many rules to the program as you want, each with a unique priority number. Do not select the same rule more than once.</p>
<b>View Description</b>	<p>Click to access the Award Category Rule page, where you can view the description that you entered in the <b>Long Description</b> field on the Award Category Rules page.</p>
<b>View Rule</b>	<p>Click to access the Award Category Rules component, where you defined the award category rule. Use your browser's back button to return to the Employee Referral Program - Rules page.</p>

---

## Managing Hot Jobs

This topic provides an overview of hot jobs and discusses how to manage hot jobs.

### Pages Used to Manage Hot Jobs

<i>Page Name</i>	<i>Definition Name</i>	<i>Usage</i>
<a href="#">Hot Jobs Page</a>	HRS_RULE_DEF	Name and describe the hot job category.

<b>Page Name</b>	<b>Definition Name</b>	<b>Usage</b>
<u>Hot Jobs - Selection Page</u>	HRS_RULE_SQL	Create SQL statements to define job opening selection criteria.
View SQL	HRS_VW_SQL	View a SQL statement that the system generates from information that you enter on the Hot Job Administration - Selection page.
<u>Hot Jobs - Job Openings Page</u>	HRS_RULE_HJ	Remove selected job openings from the hot job category and associate employee referral programs with job openings.
<u>Hot Jobs - Award Schedule Page</u>	HRS_RULE_AWD_SCH	Set up award schedules.
<u>Hot Job History Page</u>	ER_HOTJOB_HIST	View the history of a job opening's hot job status.

## Understanding Hot Jobs

Hot jobs are jobs with special award schedules that override regular employee referral program awards. You set up hot job categories, add job openings to the categories, and create an award schedule for each category.

Hot job categories are like regular award categories, but you associate hot job categories directly with job openings rather than with employee referral programs.

### Hot Job Identification

To add job openings to a hot job category, you create one or more SQL queries to select job openings that meet your criteria. When you run a query, the system adds the job openings that meet the criteria to a list that you can review and modify.

Hot jobs are not effective-dated. After job openings are marked as hot jobs, they remain hot jobs until you remove them from the list. Similarly, newly created job openings that meet the criteria to be a hot job are not automatically marked as hot jobs. You must run the selection process before adding or removing any job openings from the hot job list.

The Job Opening page identifies hot jobs by displaying a flame icon next to the job opening ID.

Certain reports also include information to identify hot jobs, including HRS003 (Job Opening Status Listing), HRS005 (Candidate Listing), and HRS006 (Job Opening Cost Analysis).

### Hot Job Eligibility and Award Schedules

The hot job award schedule overrides the award schedule that is associated with the job opening through an employee referral program. However, hot job awards are paid only if the referral satisfies the employee eligibility criteria of the employee referral program—that is, they do not override the referral program's employee eligibility criteria.

For example, suppose that an employee referral program pays awards six months after an applicant is hired, while the hot job award is paid three months after the hire date. In this situation, eligibility is checked at the three-month point but not at the six-month point. The employee referral program *eligibility rules* apply, but the hot job *awards schedule* overrides the employee referral program award schedule once the eligibility criteria are met.

---

**Note:** There is no safeguard in the system against creating hot job awards of less value than in the employee referral program award category. Therefore, you must use caution when setting up hot job awards.

---

## Hot Jobs Administration

You administer hot jobs using the Hot Job Administration (HRS\_RULE\_HOTJOB) component. Hot job administration includes these steps:

1. Name and describe a hot job category on the Hot Jobs page.
2. Create SQL statements that define job opening selection criteria on the Hot Job Administration - Selection page.
3. Click the **Select Hot Jobs** button on the Hot Job Administration - Selection page to create a list of job openings that meet your SQL selection criteria.
4. Review the list of job openings, and remove any that you don't want to include, on the Job Openings page.
5. Set up the amounts and timing of awards for the hot job category on the Award Schedule page.
6. View the history of a requisition's hot job status on the Hot Job History page.

---

**Note:** The Hot Jobs component also includes the same Awards Schedule page that appears in the Employee Referral Program component.

---

## Hot Jobs Page

Use the Hot Jobs page (HRS\_RULE\_DEF) to name and describe the hot job category.

Navigation:

**Recruiting > Employee Referrals > Hot Jobs**

This example illustrates the Hot Jobs page.

The screenshot shows a web interface with four tabs: 'Hot Jobs', 'Selection', 'Job Openings', and 'Award Schedule'. The 'Hot Jobs' tab is active. Below the tabs, the 'Rule ID' is 'KU0002'. There are three text input fields: '\*Description' containing 'Hot Job for HR Director', '\*Short Description' containing 'HRDirector', and 'Long Description' containing 'Hot Job for HR Director - \$4,000'. A small icon is visible in the top right corner of the Long Description field.

## Hot Jobs - Selection Page

Use the Hot Jobs - Selection page (HRS\_RULE\_SQL) to create SQL statements to define job opening selection criteria.

Navigation:

**Recruiting > Employee Referrals > Hot Jobs > Selection**

This example illustrates the Hot Jobs - Selection page.

The screenshot shows the 'Selection' tab active. It displays 'Rule ID KU0002' and 'Description Hot Job for HR Director'. Below this is a table titled 'Hot Job Selection Criteria' with columns: 'Open (', 'Record', '\*Field Name', '\*Operator', 'Value', 'Boolean', and 'Close )'. The table contains one row with the following values: '1', a dropdown menu, 'HRS\_JO\_I', 'HRS\_JOB\_OPENING', 'Equal To', '200003', 'AND', and another dropdown menu. At the bottom left, there is a 'View SQL' link, and at the bottom center, there is a 'Select Hot Jobs' button.

The Selection page is identical to the Referral Eligibility Rules - Rule SQL page that you use to set up employee eligibility rules with the addition of a **Select Hot Jobs** button.

See [Referral Eligibility Rules - Rule SQL Page](#).

Create SQL statements to define job opening selection criteria and then click the **Select Hot Jobs** button to load qualifying job openings into the Job Openings page.

The system does not list job openings that have already been selected into another hot job category.

If you previously created a list of job openings for this hot job category, the system reapplies the criteria, and any job opening that no longer qualifies does not appear on the list. For example, if *Open* status is a criteria, a job opening that now has *Reopen* status does not appear on the list.

## Hot Jobs - Job Openings Page

Use the Hot Jobs - Job Openings page (HRS\_RULE\_HJ) to remove selected job openings from the hot job category and associate employee referral programs with job openings.

Navigation:

**Recruiting > Employee Referrals > Hot Jobs > Job Openings**

This example illustrates the Hot Jobs - Job Openings page.

### Hot Jobs

<i>Field or Control</i>	<i>Description</i>
<b>Referral Program ID</b>	If you have associated the job opening with an employee referral program, the employee referral program ID appears here. If the job opening is not associated with an employee referral program, select one here. You must associate a job opening with an employee referral program; otherwise, the system cannot determine employee eligibility for awards.

### Action Buttons

<i>Field or Control</i>	<i>Description</i>
<b>Remove Selected</b>	Click to remove job openings for which you have selected the <b>Select Row</b> check box. The system removes the job openings when you save.
<b>Remove All</b>	Click to remove all job openings from the list. The system removes the job openings when you save.

## Hot Jobs - Award Schedule Page

Use the Hot Jobs - Award Schedule page (HRS\_RULE\_AWD\_SCH) to set up award schedules.

Navigation:

**Recruiting > Employee Referrals > Hot Jobs > Award Schedule**

This is the same page as the [Award Schedule Page](#) in the Award Category Rules component.

## Hot Job History Page

Use the Hot Job History page (ER\_HOTJOB\_HIST) to view the history of a job opening's hot job status.

Navigation:

**Recruiting > Employee Referrals > Hot Job History**

This example illustrates the Hot Job History page.

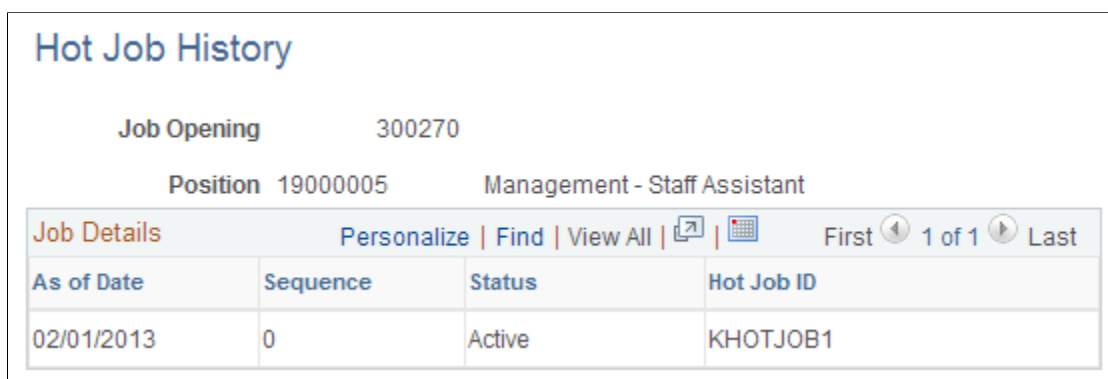

## Processing Employee Referrals

This topic provides overviews of the Employee Referral Program (HRS\_ERP\_MAIN) process and of payment statuses. It then discusses how to process eligibility and awards.

### Page Used to Process Eligibility and Awards

<i>Page Name</i>	<i>Definition Name</i>	<i>Usage</i>
<a href="#">Process Referral Programs Page</a>	HRS_ERP_RUN	Process eligibility and awards and submit awards to Payroll for North America.

## Understanding the Employee Referral Program Process

When you set up employee referral programs, you capture time-sensitive rules that dictate eligibility and awards for each referral under the particular employee referral program. The Employee Referral Program process applies these time-sensitive rules at the appropriate times in a referral's life span.

It is necessary to establish which employee referral program a referral is associated with before determining eligibility and awards. This association occurs only when an applicant is hired into a job



opening that has an employee referral program associated. Therefore, you cannot determine eligibility and awards before an applicant is hired.

You can run the Employee Referral Program process for a specific employee referral program or for all employee referral programs. The Employee Referral Program process determines eligibility, creates awards, and processes award payments through PeopleSoft Payroll for North America, depending on the options that you select on the run control page. If you select the **Eligibility and Awards Rules** option on the Process Referral Programs page, the system determines whether the referring employee is eligible for employee referral program awards and determines the amount and timing of awards. If you select the **Interface to Payroll for NA** option, the system processes award payments through Payroll for North America.

See [Approving and Paying Referral Awards](#).

## Eligibility Processing

The Employee Referral Program process checks employee eligibility according to the rules and criteria set up in the employee referral program for the following three dates:

- Referral date.
- Hire date.
- Award date.

You associate rules with these dates by using the **When to Apply** field on the Employee Referral Program - Rules page in the Employee Referral Program (HRS\_REF\_PGM) component. Criteria apply at various times depending on the particular criteria or on how you set up the program. This table shows the dates for which the rules and criteria are processed:

<i>Rule or Criterion</i>	<i>Referral Date</i>	<i>Hire Date</i>	<i>Award Date</i>
Employee eligibility rules	Determined by the value in the <b>When to Apply</b> field on the Employee Referral Program - Rules page.	Determined by the value in the <b>When to Apply</b> field on the Employee Referral Program - Rules page.	Determined by the value in the <b>When to Apply</b> field on the Employee Referral Program - Rules page.
Award category rules	NA	Applies	NA
Referral life span criteria	NA	Applies (checks the referral life span value in the <b>Limit Referral Life Span To</b> field on the Employee Referral Program - Criteria page against the time elapsed between the referral and hire dates).	NA

<b>Rule or Criterion</b>	<b>Referral Date</b>	<b>Hire Date</b>	<b>Award Date</b>
Employee is a direct or indirect manager of the hired applicant	NA	Applies if the <b>Disqualify if applicant reports to the referring employee</b> option is selected on the Employee Referral Program - Criteria page.	NA
Manager level criteria	NA	Applies (checks the value in the <b>Disqualify employee if their Manager Level is greater than or equal to</b> field on the Employee Referral Program - Criteria page).	NA
Previous employee criteria	May apply, depending on whether the <b>Allow Previous Employees</b> option is selected and on the value in the <b>prior to the</b> field on the Employee Referral Program - Criteria page.	May apply, depending on whether the <b>Allow Previous Employees</b> , option is selected and on the value in the <b>prior to the</b> field on the Employee Referral Program - Criteria page.	NA
Family member referral criteria	NA	Applies if the <b>Allow Family Member Referrals</b> option is selected on the Employee Referral Program - Criteria page.	NA
Applicant must be actively employed	NA	Applies	Applies

### When Eligibility is Not Recalculated

The Employee Referral Program process does not recalculate eligibility for every referral in an employee referral program every time that it runs. It does not process or reprocess eligibility under the following conditions:

- The applicant has not been hired.
- The referral has been processed and marked ineligible.
- The referral was processed and marked eligible as of the hire date, but the award date has not been reached when the process runs again.
- The eligibility status has been overridden and not marked as a reprocess.

## Reprocessing Eligibility for Duplicate Applicants

Duplicate applicant records can result in erroneous employee referral program eligibility results after the applicant data is merged. Before the duplicate applicant records are merged, there can be multiple distinct applicant records and multiple distinct referral records all for the same applicant. After merging, there is only one applicant record, but the system maintains multiple referral records. You must run the Employee Referral Program process again to make sure the eligibility status is correct because the original results were based on an unmerged data set. You can override eligibility on the Administer Referrals (HRS\_REF\_ADMN) component and rerun the Employee Referral Program process, if necessary.

You can distribute the referral award among multiple eligible employees on the Review Duplicate Referrals page.

## Awards Processing

After checking eligibility, the Employee Referral Program process begins award processing if the referral meets both of the following conditions for a particular employee referral program:

- Applicant is hired.
- Employee is eligible as of the referral date (if any rules apply) and as of the applicant's hire date.

During award processing, the system:

1. Checks the job opening that the applicant was hired into against the employee referral program's award category rules.
  - a. If the job opening *is not* in any of the award categories, the process sets the eligibility status to Ineligible and issues a message that the job opening is not covered by the employee referral program.
  - b. If the job opening *is* in an award category, the process schedules awards.

The first award category rule that the job opening satisfies determines the award schedule.

For example, if you define an award category rule for IT jobs and another for Executive Level jobs, an IT Executive level job would be associated with the rule that is first in the list of award categories.

2. Checks hot jobs.

If the job opening is a hot job, the hot job award schedule overrides the award schedule of the employee referral program award category rule.

## Understanding Payment Statuses

This table describes payment status values that you might see in the **Payment Status** field when viewing employee referral program award data. Unless otherwise specified, *payroll* refers to PeopleSoft Payroll for North America only:

<b>Payment Status</b>	<b>Description</b>	<b>Process that Writes Status</b>
Approved - Goes to Payroll (AP)	Approved award that has not yet been submitted for payment.	<ul style="list-style-type: none"> <li>Entered by the Employee Referral Program process if you select <b>Eligibility and Awards Rules</b> on the Process Referral Programs page and deselect the <b>Require Approval for Payment</b> option on the Employee Referral Program - Employee Referral Programs page.</li> <li>Entered manually on the Referral Award Details page if you select the <b>Require Approval for Payment</b> option on the Employee Referral Program - Employee Referral Programs page or after correcting rejected awards.</li> </ul>
Needs Approval (NA)	The employee referral program requires approval of awards and this award has not yet been approved.	<ul style="list-style-type: none"> <li>Entered by the Employee Referral Program process if you select the <b>Eligibility and Awards Rules</b> option on the Process Referral Programs page and select the <b>Require Approval for Payment</b> on the Employee Referral Program - Employee Referral Programs page.</li> <li>Entered manually on the Referral Award Details page if a nonapprover corrects rejected awards.</li> </ul>
Cancelled (CN)	Plan administrator cancels an award.	Entered manually on the Referral Award Details page.
Sent to Payroll (SP)	Awards have been published to Payroll for North America.	Entered by the Employee Referral Program process if you select <b>Interface to Payroll for NA</b> (interface to Payroll for North America) on the Process Referral Programs page.
Taken by Payroll (TP)	Payroll confirms receipt of award.	Entered by the Employee Referral Program process if you select <b>Interface to Payroll for NA</b> on the Process Referral Programs page.
Paid (PD)	Payroll has paid award.	Entered by the Employee Referral Program process if you select <b>Interface to Payroll for NA</b> on the Process Referral Programs page.
Rejected by Payroll (RP)	Payroll rejects award payment. This is typically due to erroneous data.	Entered by the Employee Referral Program process if you select <b>Interface to Payroll for NA</b> on the Process Referral Programs page.

<b>Payment Status</b>	<b>Description</b>	<b>Process that Writes Status</b>
Reversed by Payroll (RV)	Payroll reverses award payment. This is typically due to an employee being incorrectly paid.	Entered by the Employee Referral Program process if you select <b>Interface to Payroll for NA</b> on the Process Referral Programs page.

## Process Referral Programs Page

Use the Process Referral Programs page (HRS\_ERP\_RUN) to process eligibility and awards and submit awards to Payroll for North America.

Navigation:

**Recruiting > Employee Referrals > Process Referral Programs**

This example illustrates the Process Referral Programs page.

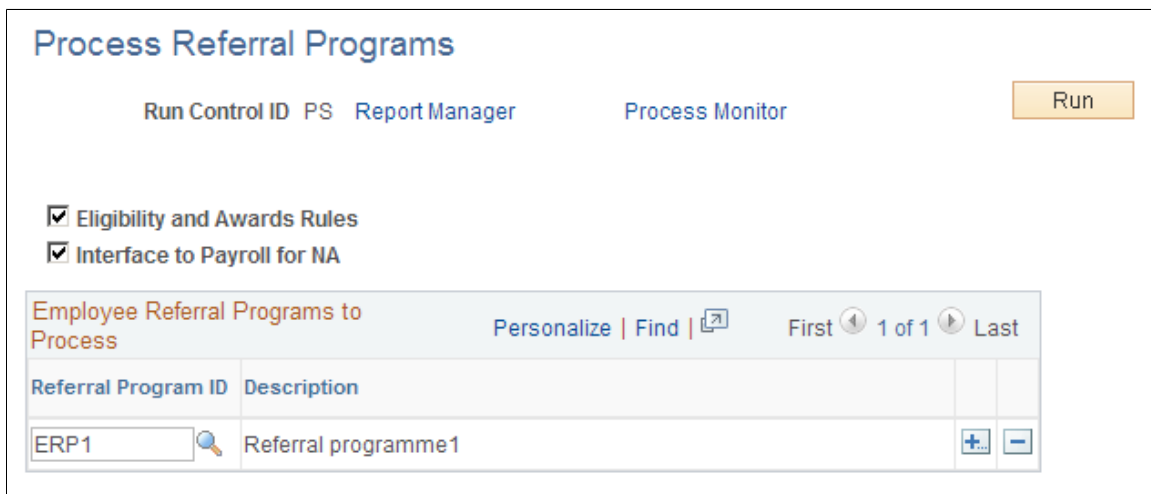

Click **Run** to run this request. PeopleSoft Process Scheduler runs the Employee Referral Program process at user-defined intervals.

<b>Field or Control</b>	<b>Description</b>
<b>Eligibility and Awards Rules</b>	Select to process eligibility and create awards.
<b>Interface to Payroll for NA</b> (interface to Payroll for North America)	Select to process award payments through Payroll for North America.
<b>Referral Program ID</b>	Select the employee referral programs that you want to process. You can add rows as necessary. If you do not select an employee referral program, the process runs for all employee referral programs.

## Reviewing and Overriding Referral Awards

This topic provides an overview of referral overrides and discusses how to review and override referral awards.

### Pages Used to View and Override Referral Awards

<i>Page Name</i>	<i>Definition Name</i>	<i>Usage</i>
<a href="#">Referral Administration Page</a>	HRS_REF_ADMN_MAIN	View referral summary information.
<a href="#">Administer Referrals - Eligibility page</a>	HRS_REF_ADMN_ELIG	View and override employee eligibility.
<a href="#">Administer Referrals - Awards Page</a>	HRS_REF_ADMN_AWD	View awards.
<a href="#">Referral Award Details Page</a>	HRS_EE_REF_AWD_OVR	Override award details.  When you access the Referral Award Details page from the Approve Employee Awards page, the Referral Award Details page is display-only.
<a href="#">Application Summary Page</a>	HRS_REF_ADMN_APPDT	View eligibility by application.
<a href="#">Track Duplicate Referrals Page</a>	HRS_DUP_REF	View and override duplicate referrals.
<a href="#">Eligibility Overrides Page</a>	HRS_AUDIT_OVR_ELIG	View the audit details of manual overrides to eligibility data. You can select overrides by applicant, by employee, or by the administrator who overrode the audited field. Only referrals that contain audit information are available in the search.
<a href="#">Award Overrides Page</a>	HRS_AUDIT_OVR_AWD	View the audit details of manual overrides to award data.

### Understanding Referral Overrides

To manage referral overrides:

- View and override eligibility and award information for referrals by using the Administer Referrals component.
- View duplicate referrals and adjust award amounts among eligible employees by using the Track Duplicate Referrals page.

- View an audit list of manual overrides, including who made the change, when the change was made, and details of the change, by using the Review Override Audit (HRS\_OVERRIDE\_AUDIT) component.

## Referral Administration Page

Use the Referral Administration page (HRS\_REF\_ADMN\_MAIN) to view referral summary information.

Navigation:

**Recruiting > Employee Referrals > Administer Referrals > Referral Administration**

This example illustrates the Referral Administration page.

The screenshot shows the 'Referral Administration' page with the following details:

- Tabs:** Referral Administration (selected), Eligibility, Awards, Application Summary
- Employee Information:**
  - Empl ID: KUTZ502, Name: Joseph Randall
  - Department: 10500, Benefits: Benefits
- Applicant Information:**
  - Applicant ID: 139, Name: Victoria Newman
  - Empl ID: KUZ102, Hire Date: 12/11/2000
  - Job Opening ID: 200002, Position: Specialist-Pension
- Job Requisitions Referred Table:**

Job Opening	Posting Title	Department	Requisition Status	Status Date
200002	Specialist-Pension	10500	110 Filled/Closed	12/11/2000

### Job Requisitions Referred

Use this group box to view information for all job openings to which the employee has referred the applicant.

## Administer Referrals - Eligibility page

Use the Administer Referrals - Eligibility page (HRS\_REF\_ADMN\_ELIG) to view and override employee eligibility.

Navigation:

**Recruiting > Employee Referrals > Administer Referrals > Eligibility**

This example illustrates the Administer Referrals - Eligibility page.

Referral Administration		Eligibility		Awards		Application Summary	
<b>Employee Information</b>							
Empl ID		KUTZ502		Joseph Randall			
Department		10500		Benefits			
<b>Applicant Information</b>							
Applicant ID		139		Victoria Newman			
Empl ID		KUZ102		Hire Date		12/11/2000	
Job Opening ID		200002		Specialist-Pension			
<b>Employee Eligibility</b>							
Referral Program ID		KU_ERP_01		ERP for US-based jobs			
*Status		Ineligible		<input type="checkbox"/> Reprocess Eligibility/Awards			
Creation Date		06/19/2002		Profile Seq		1	
Event Type		General Eligibility Criteria		Event Date		02/15/2005	
Comments		Applicant was hired before being referred.					

### Employee Eligibility

Use this group box to view eligibility data for each eligibility rule that is defined in the **Employee Eligibility Rules** group box on the Employee Referral Program - Rules page.

If the applicant has not been hired, the system issues the following message: "Eligibility has not yet been determined" in place of the fields in the **Employee Eligibility** group box.

Field or Control	Description
<b>Status</b>	Displays the current employee eligibility status. Values are <i>Eligible</i> and <i>Ineligible</i> . You can override the <i>Eligible</i> status only if the award has not been submitted for payment. If you manually change the status from <i>Ineligible</i> to <i>Eligible</i> , the system does not reprocess eligibility rules that are evaluated as of the referral date or hire date.
<b>Reprocess Eligibility/Awards</b>	Select to rerun all eligibility and awards processing the next time that you run the Employee Referral Program process. This option is unavailable if any of the awards for the referral have been sent to the payroll system.
<b>Creation Date</b>	Displays the date that the eligibility status was originally determined by the system.



<b>Field or Control</b>	<b>Description</b>
<b>Event Type</b>	<p>Displays the category of the rule or criteria that causes the ineligibility status. This field appears on the page only when the eligibility status is Ineligible. Values are:</p> <ul style="list-style-type: none"> <li>• <i>Award Eligibility Rule:</i> Eligibility rule associated with the award date in the <b>When to Apply</b> field on the Employee Referral Program - Rules page.</li> <li>• <i>General Eligibility Criteria:</i> Any of the criteria defined on the Employee Referral Program - Criteria page.</li> <li>• <i>Hire Eligibility Rule:</i> Eligibility rule associated with the applicant's hire date in the <b>When to Apply</b> field on the Employee Referral Program - Rules page.</li> <li>• <i>Manual Override:</i> Manual change on this page.</li> <li>• <i>Referral Eligibility Rule:</i> Eligibility rule associated with the referral date in the <b>When to Apply</b> field on the Employee Referral Program - Rules page.</li> </ul>
<b>Event Date</b>	<p>Displays the date that the eligibility status was last changed. This field appears on the page only when the eligibility status is Ineligible.</p>
<b>Comments</b>	<p>Displays a comment that explains the reason for the eligibility status. You can manually enter a comment that supersedes the system-generated comment.</p> <p>If you manually change the eligibility status, the system enters this comment: "Manual override by administrator." You can view details of a manual override on the Eligibility Overrides page.</p>





## Administer Referrals - Awards Page

Use the Administer Referrals - Awards page (HRS\_REF\_ADMN\_AWD) to view awards.

Navigation:

**Recruiting > Employee Referrals > Administer Referrals > Awards**

This example illustrates the Administer Referrals - Awards page.

<a href="#">Referral Administration</a>	<a href="#">Eligibility</a>	<a href="#">Awards</a>	<a href="#">Application Summary</a>		
<b>Employee Information</b>					
Empl ID	KUTZ502	Joseph Randall			
Department	10500	Benefits			
<b>Applicant Information</b>					
Applicant ID	147	Eric English			
Empl ID	KUZ112	Hire Date	12/09/2000		
Job Opening ID	200012	Auditor-General			
<b>Awards</b>					
Personalize   Find    			First  1 of 1  Last		
Award Date	Payment Status	Earnings Code	Referral Program ID	Award Value	Details
06/09/2001	Needs Approval	RFA	KU_ERP_01	1500.00	<a href="#">Details</a>

Field or Control	Description
<b>Award Date</b>	Displays the award date. The system calculates this date according to the duration in the award schedule.
<b>Payment Status</b>	Displays the payment status.  See <a href="#">Understanding Payment Statuses</a> .
<b>Award Value</b>	Displays the award value. The system determines this value based on the award schedule of the award category.
<b>Details</b>	Click to access the Referral Award Details page, where you can override award details.

## Referral Award Details Page

Use the Referral Award Details page (HRS\_EE\_REF\_AWD\_OVR) to override award details.

Navigation:

- Click the **Details** link on the Administer Referrals - Awards page.
- Click the **Details** link on the Approve Employee Awards page.

This page is display-only.

- Click the **Edit** link on the Rejected Awards page.

This example illustrates the Referral Award Details page.

### Referral Award Details

Joseph Randall
Empl ID KUTZ502

\*Award Date

Description

\*Earnings Code  Referral Award

Payment Status Needs Approval

\*Payment Status Override

Status Date/Time 06/19/2002 10:59:30AM

\*Dept Charged  Finance and Administration

\*Award Value

Actual Amount Paid

\*Currency Code

Separate Check

Gross-Up

Referral Program ID KU\_ERP\_01 ERP for US-based jobs

Require Approval for Payment

OK
Cancel

Much of the data on this page reflects the rules and criteria that are set up for the employee referral program. You can override the value in any editable field.

<b>Field or Control</b>	<b>Description</b>
<b>Award Date</b>	Displays the award date. The system calculates this date according to the award schedule rules.
<b>Description</b>	Displays the description that you specified for the award on the Award Schedule page.

<b>Field or Control</b>	<b>Description</b>
<b>Payment Status Override</b>	<p>Select a payment status. Use this field to manually approve an award that has <i>Needs Approval</i> status. You can do this only if the eligibility status is <i>Eligible</i>.</p> <p>The employee referral program administrator can manually change the payment status to or from <i>Needs Approval</i>, <i>Approved</i>, or <i>Cancelled</i>.</p> <p>You cannot manually override the status of an award that is submitted to be paid, unless Payroll for North America has rejected it.</p> <p>If an award has been rejected by Payroll for North America, the employee referral program administrator can change a <i>Rejected by Payroll</i> or <i>Reversed by Payroll</i> status to one of these values:</p> <ul style="list-style-type: none"> <li>• <i>Cancelled</i>: You accept the reason for the rejection and do not intend to correct it.</li> <li>• <i>Needs approval</i>: You corrected the reason for the rejection and now the award is ready to be approved again.</li> <li>• <i>Approved</i>: You corrected the reason for the rejection and now the award is ready to be submitted when the process runs again for the employee referral program.</li> </ul>
<b>Dept Charged</b> (department charged)	Displays the department (of the job opening) into which the applicant was hired.
<b>Award Value</b>	Displays the amount of the award as defined in the award schedule.
<b>Actual Amount Paid</b>	Displays the value that is entered when the award is paid through Payroll for North America.
<b>Currency Code</b>	Displays the currency in which the award is paid to the employee.
<b>Separate Check</b>	Select to override the default that you set up on the Employee Referral Program - Employee Referral Programs page.
<b>Gross-Up</b>	Select to override the default that you set up on the Award Schedule page. If you select this option and use Payroll for North America, the award is paid by a separate check.
<b>Require Approval for Payment</b>	Set the value for this field on the Employee Referral Program - Employee Referral Programs page. You cannot change it here.

<b>Field or Control</b>	<b>Description</b>
<b>Rejected Reason</b>	Displays the reason that Payroll for North America rejected the award. This field only appears when the award is rejected by the payroll system.
<b>Last Manual Override</b>	Displays the date of the last manual override. You can view details of the override on the Award Overrides page. This field only appears when an administrator manually changes an award payment-related field.

## Application Summary Page

Use the Application Summary page (HRS\_REF\_ADMN\_APPDT) to view eligibility by application.

Navigation:

**Recruiting > Employee Referrals > Administer Referrals > Application Summary**

This example illustrates the Application Summary page.

The screenshot shows a web interface with the following sections:

- Navigation Tabs:** Referral Administration, Eligibility, Awards, Application Summary (selected).
- Employee Information:**
  - Empl ID: KUTZ502, Name: Joseph Randall
  - Department: 10500, Benefits
- Applicant Information:**
  - Applicant ID: 147, Name: Eric English
  - Empl ID: KUZ112, Hire Date: 12/09/2000
  - Job Opening ID: 200012, Position: Auditor-General
- Eligibility by Application:**
  - Referral Program ID: KU\_ERP\_01, Description: ERP for US-based jobs
  - Status: Ineligible, Profile Seq: 1
  - Event Type: General Eligibility Criteria, Event Date: 02/15/2005
  - Comments: Applicant was hired before being referred.

This page shows all the dates on which the employee referred the applicant and the employee's eligibility status for each referral. Remember that eligibility for award payment is determined by the job opening into which the applicant is hired.

<b>Field or Control</b>	<b>Description</b>
<b>Comments</b>	Displays the reason if the eligibility status is Ineligible.

## Track Duplicate Referrals Page

Use the Track Duplicate Referrals page (HRS\_DUP\_REF) to view and override duplicate referrals.

Navigation:

**Recruiting > Employee Referrals > Track Duplicate Referrals**

This example illustrates the Track Duplicate Referrals page.

### Track Duplicate Referrals

McPhedran,Neil Applicant ID 140

The following employees have referred the current applicant. The employees are listed below in the order in which they referred the applicant. The employee at the top is the primary referrer, and is scheduled to receive the awards. If you wish to split the awards among the following employees you may do so by adjusting the award records below.

Original Award Total	\$6,000.00
Current Award Total	\$12,000.00

---

Empl ID KUTZ501  
Name Alec Billings  
Award Total \$6,000.00  
Referral Time Stamp 07/23/01 12:00PM

Award Schedule				
Award Date	*Earnings Code	*Award Value	Description	
06/10/2001	RFA	\$4,000.00	HR Director Hot Job Award	-
05/12/2002	RFA	\$2,000.00	HR Director Hot Job Award	-

Empl ID KUTZ503  
Name Phyllis Sterling  
Award Total \$6,000.00  Ineligible for referral award  
Referral Time Stamp 07/23/01 12:04PM

Award Schedule				
Award Date	*Earnings Code	*Award Value	Description	
06/10/2001	RFA	\$4,000.00	HR Director Hot Job Award	-
05/12/2002	RFA	\$2,000.00	HR Director Hot Job Award	-

Save
Refresh

Employees appear on this page in the order in which they referred the applicant. The first employee that appears is the first employee who referred the applicant, and so on.

The total award for all employees can be more than the original award if you selected **Allow Dups to Exceed Original** (allow duplicates to exceed original) on the Employee Referral Program - Criteria page when you set up the employee referral program.

<i>Field or Control</i>	<i>Description</i>
<b>Original Award Total</b>	Displays the total value of all awards in the original award schedule.
<b>Current Award Total</b>	Displays the total of all awards entered on the page for all the referring employees.
<b>Refresh</b>	Click to refresh the award total amounts in the <b>Current Award Total</b> and <b>Award Total</b> fields.

### Employee-Specific Page Elements

<i>Field or Control</i>	<i>Description</i>
<b>Award Total</b>	Displays the total value of all awards for the employee.
<b>Referral Time Stamp</b>	Displays the date and time that the employee submitted the referral.
<b>Award Value</b>	Adjust the award amount for each employee.
<b>Ineligible for referral award</b>	Select this check box to prevent the employee from receiving referral awards. This option is not available for the first employee who submitted the referral.

### Eligibility Overrides Page

Use the Eligibility Overrides page (HRS\_AUDIT\_OVR\_ELIG) to view the audit details of manual overrides to eligibility data.

You can select overrides by applicant, by employee, or by the administrator who overrode the audited field. Only referrals that contain audit information are available in the search.

Navigation:

**Recruiting > Employee Referrals > Review Override Audit > Eligibility Overrides**

This example illustrates the Eligibility Overrides page .

<a href="#">Eligibility Overrides</a>		<a href="#">Award Overrides</a>			
Applicant ID		139 Newman,Victoria			
Employee ID		KUTZ502 Joseph Randall			
<a href="#">View Referral Information</a>					
<b>Override Audits</b>		Personalize   Find   View All			
		First 1 of 1 Last			
User ID	Name	Date and Time Stamp	Field Changed	Old Value	New Value
PS	Betty Locherty	02/01/2013 8:41:32.471451PM	ERP Eligibility Status	Ineligible	Eligible

<b>Field or Control</b>	<b>Description</b>
<b>View Referral Information</b>	Click to access the Referral Administration page, where you can review detailed information about the referral.
<b>User ID, Name, and Date and Time Stamp</b>	These fields display information about who overrode the eligibility value for this award and when the override occurred.
<b>Field Changed, Old Value, and New Value</b>	These fields display information about the data that changed when the override occurred.

## Award Overrides Page

Use the Award Overrides page (HRS\_AUDIT\_OVR\_AWD) to view the audit details of manual overrides to award data.

Navigation:

**Recruiting > Employee Referrals > Review Override Audit > Award Overrides**

This example illustrates the Award Overrides page.

<a href="#">Eligibility Overrides</a>		<a href="#">Award Overrides</a>			
Applicant ID		139 Newman,Victoria			
Employee ID		KUTZ502 Joseph Randall			
<a href="#">View Referral Information</a>					
<b>Employee Referral Award Overrides</b>		Personalize   Find   View All			
		First 1 of 1 Last			
User ID	Name	Audit Date/Time	Field Changed	Old Value	New Value
PS	Betty Locherty	02/01/2013 8:47:02.950382PM	Award Value	1500	1600

This page is identical to the Eligibility Overrides page, but the data refers to award overrides rather than eligibility overrides.



## Approving and Paying Referral Awards

This topic provides overviews of award approvals and paying awards, and discusses how to approve and pay referral awards.

### Pages Used to Approve and Pay Referral Awards

<i>Page Name</i>	<i>Definition Name</i>	<i>Usage</i>
<a href="#">Approve Employee Awards Page</a>	HRS_MASS_APRV	Approve referral awards that have the status of Needs Approval.
<a href="#">Process Referral Programs Page</a>	HRS_ERP_RUN	Submit awards to Payroll for North America and process eligibility and awards.
<a href="#">Rejected Awards Page</a>	HRS_REJECTED_AWDS	View rejected awards.
<a href="#">Referral Award Details Page</a>	HRS_EE_REF_AWD_OVR	Override award details.  When you access the Referral Award Details page from the Approve Employee Awards page, the Referral Award Details page is display-only.

### Understanding Award Approvals

When you set up the employee referral program, define whether awards require approval before payment. If approval is required, the system assigns the awards the Needs Approval payment status when you run the Employee Referral Program process. You must manually approve the awards.

To manually approve awards, you can:

- Use the Approve Employee Awards page to approve all awards or selected awards in the employee referral program when the payment status is Needs Approval.
- Use the Rejected Awards page to correct and approve awards when the payment status is Rejected by Payroll.

See [Rejected Awards Page](#).

- Use the Referral Award Details page in the Administer Referrals component to override award details and approve the award when the payment status is other than Needs Approval or Rejected by Payroll.

See [Referral Award Details Page](#).

## Understanding Paying Awards

The interface between employee referral programs and payroll processing depends upon the payroll system that you use to pay the referring employee. If you pay employees through Payroll for North America, use the Employee Referral Program process to send the monetary and non-stock, non-monetary awards directly to Payroll for North America using PeopleSoft Integration Broker. If you pay employees through a payroll system other than Payroll for North America, you must create an interface to that payroll system.

Access the Process Referral Programs page and select the **Interface to Payroll for NA** option to run the Employee Referral Program process. The same process is used to determine eligibility and create awards.

The Employee Referral Program process:

- Submits awards for payment.

The process sends approved awards to payroll that have been scheduled with an award date prior to or equal to the current date. The process does not submit awards that have already been submitted or awards that are future-dated.

- Updates the payment status for each submitted award to Sent to Payroll.
- Retrieves paid award information from Payroll for North America.

After payroll pays an award and publishes the results, the subscription process retrieves payment information and updates these records:

- Employee referral program data records (HRS\_EE\_REF\_AWD).
- Job opening expense data (HRS\_JO\_EXP).

The job opening expense amount is the amount that is paid by payroll, including taxes that have been grossed up. You can view the expense information on the Job Opening - Activity & Attachments and Add Expenses pages. The expense code value is *Referral Fee*.

The payroll system:

- Calculates gross-up amounts and taxes.
- Pays the cash awards.
- Posts the amounts to the appropriate general ledger account.

If the currency code of the award does not match the currency code of the employee's pay group, the award is rejected and the employee referral program administrator must use the Rejected Awards page to override the values.

If the converted amount of the award is greater than 8.2 digits, the award is rejected and the employee referral program administrator must use the Rejected Awards page to split the award into two payments.

### Integration with Payroll for North America Process Flow

This table outlines the award payout integration between employee referral programs and Payroll for North America:

<b><i>Integration Step</i></b>	<b><i>Description</i></b>
Employee referral program publishes a payment request for approved awards to payroll.	<p>Publishes the award amount in the currency of the award category.</p> <p>Sets the award's payment status to Sent to Payroll.</p>
Payroll subscribes to the payment request, which automatically runs a PeopleSoft Application Engine process to validate or reject the award data and publishes an acknowledgement of acceptance or rejection.	<p>Subscription inserts the awards into a subscribing staging table.</p> <p>Validation checks for error conditions that require correction prior to loading to paysheet.</p> <p>If award data is valid, the system inserts the awards into the application table and publishes an acknowledgement that sets the award's payment status to Taken by Payroll.</p> <p>If errors are detected, the system publishes an acknowledgment that sets the award's payment status to Rejected by Payroll and supplies a reason code.</p>
Employee referral program subscribes to the acknowledgement of rejected awards or awards with errors.	Employee referral program administrator uses the Rejected Awards page to view the reason for rejection and the Referral Award Details page to correct the award data.
Payroll processes validated awards and issues checks.	Payroll creates paysheets, calculates gross-up amounts and taxes, confirms pay, issues checks, and posts amounts to the general ledger.
Payroll runs a PeopleSoft Application Engine process to send a notification of payment.	This process runs after payments are calculated and confirmed.
Employee referral program subscribes to the notification of payment.	The subscription updates the award's payment status to Paid or Reversed by Payroll and updates the status date and time, actual amount paid, paycheck status, paycheck number, and check date.

## Integration Points

This table describes the service operation that are used to transfer awards and payout data between Recruiting Solutions and Payroll for North America:

<b>Integration Point</b>	<b>Service Operation</b>	<b>Definition</b>
ERECRUIT REQUEST FOR PAYMENT	PAYMENT_ERECRUIT_REQUEST	Recruiting Solutions publishes award data to payroll and payroll subscribes to the award data.
ACKNOWLEDGMENT/ VERIFICATION OF ERECRUIT PAYMENT	PAYMENT_ERECRUIT_ACKNOWLEDGE	Payroll validates the requested awards and publishes the results of validation. Recruiting Solutions subscribes to the acknowledgement.
PAYROLL ISSUED ERECRUIT PAYMENT	PAYMENT_ERECRUIT_ISSUED	Payroll publishes notification of payment and Recruiting Solutions subscribes to the notification.

## Approve Employee Awards Page

Use the Approve Employee Awards page (HRS\_MASS\_APRV) to approve referral awards that have the status of Needs Approval.

Navigation:

**Recruiting > Employee Referrals > Approve Employee Awards**

This example illustrates the Approve Employee Awards page.

### Approve Employee Awards

Description ERP for US-based jobs Referral Program ID KU\_ERP\_01

Awards to Approve
Personalize | Find | View All | First 1-7 of 12 Last

Select	Award Date	Empl ID	Name	Award Value	Description	Details
<input type="checkbox"/>	06/14/2001	KUTZ500	Joan Foster	1,500.00	Finance Dept Ref Award	<a href="#">Details</a>
<input type="checkbox"/>	06/11/2001	KUTZ501	Alec Billings	1,500.00	Finance Dept Ref Award	<a href="#">Details</a>
<input type="checkbox"/>	06/11/2001	KUTZ501	Alec Billings	500.00	Cash	<a href="#">Details</a>
<input type="checkbox"/>	06/10/2001	KUTZ501	Alec Billings	4,000.00	HR Director Hot Job Award	<a href="#">Details</a>
<input type="checkbox"/>	05/12/2002	KUTZ501	Alec Billings	2,000.00	HR Director Hot Job Award	<a href="#">Details</a>
<input type="checkbox"/>	06/13/2001	KUTZ504	Maryellen McBride	750.00	Fine Cheese Basket	<a href="#">Details</a>
<input type="checkbox"/>	06/10/2001	KUTZ505	Ione Crane	129.00	Fancy Fruit Basket	<a href="#">Details</a>

Select All    Deselect All    Approve

All awards that have the Needs Approval payment status appear on this page.

<i>Field or Control</i>	<i>Description</i>
<b>Select</b>	Select the referral awards that you want to approve.
<b>Details</b>	Click to access the Referral Award Details page, where you can view referral award details.
<b>Select All</b>	Click to select all referral awards in the list, including those outside the view area.
<b>Approve</b>	Click to approve the selected referral awards. After awards are approved, they do not appear on this page again.

## Process Referral Programs Page

Use the Process Referral Programs page (HRS\_ERP\_RUN) to submit awards to Payroll for North America and process eligibility and awards.

Navigation:

**Recruiting > Employee Referrals > Process Referral Programs > Employee Referral Programs**

See [Process Referral Programs Page](#).

## Rejected Awards Page

Use the Rejected Awards page (HRS\_REJECTED\_AWDS) to view rejected awards.

Navigation:

**Recruiting > Employee Referrals > Review Rejected Awards > Rejected Awards**

<b>Field or Control</b>	<b>Description</b>
<b>Rejected Reason</b>	Displays the reason that Payroll for North America rejected the award. Use this to determine which data to correct. Values are: <ul style="list-style-type: none"> <li>• <i>Amount Exceeds Payroll Maximum</i></li> <li>• <i>Expenses Sheet in Error</i></li> <li>• <i>Invalid Currency Code</i></li> <li>• <i>Invalid Earning Code</i></li> <li>• <i>Invalid Employee ID &amp; Record #</i> (invalid employee ID and record number)</li> <li>• <i>Problem in loading to file</i></li> <li>• <i>Reject All - Requested by User</i></li> <li>• <i>Transaction Already Exists</i></li> </ul>
<b>Edit</b>	Click to access the Referral Award Details page, where you can correct the error that caused rejection.

## Referral Award Details Page

Use the Referral Award Details page (HRS\_EE\_REF\_AWD\_OVR) to override award details.

Navigation:

- Click the **Details** link on the Administer Referrals - Awards page.
- Click the **Details** link on the Approve Employee Awards page.

This page is display-only.

- Click the **Edit** link on the Rejected Awards page.

---

**Note:** You can also override or reprocess eligibility for a rejected award on the Administer Referrals - Eligibility page.

---

### Related Links

[Referral Award Details Page](#)

[Administer Referrals - Eligibility page](#)

## Chapter 30

# Action Availability Reference

## Action Availability Reference

The table in this topic lists recruiting actions, the pages where each action can be invoked, the menu or other page element where the action can be found on each page, and any conditions that must be met for the action to be available.

For more information about actions, see [Understanding Actions for Managing Applicants](#).

<b>Action</b>	<b>Search Applicants Page</b>	<b>Manage Applicant Page</b>	<b>Search Applications Page</b>	<b>Manage Application Page</b>	<b>Manage Job Opening Page</b>	<b>Manage Applicant List Page</b>
Accept Offer <hr/> <b>Note:</b> An offer in the default (extended) or pending status must exist.	Not available	<b>Other Actions &gt; Recruiting Actions</b>	<b>Other Actions &gt; Recruiting Actions</b>	<ul style="list-style-type: none"> <li><b>Other Actions &gt; Recruiting Actions</b></li> <li>Also available as a link on the Offer tab of this page.</li> </ul>	<b>Other Actions &gt; Recruiting Actions</b>	Not available
Add Applicant Note <hr/> <b>Note:</b> This action is not available to users with the Hiring Manager role.	Not available	Toolbar button	<b>Other Actions &gt; Applicant Actions</b>	<b>Other Actions &gt; Applicant Actions</b>	<b>Other Actions &gt; Applicant Actions</b>	Add Note icon
Add Applicant to List	<ul style="list-style-type: none"> <li>Actions menu</li> <li>Group Actions menu</li> </ul>	Toolbar button	<ul style="list-style-type: none"> <li><b>Other Actions &gt; Applicant Actions</b></li> <li><b>Group Actions &gt; Applicant Actions</b></li> </ul>	<b>Other Actions &gt; Applicant Actions</b>	<ul style="list-style-type: none"> <li><b>Other Actions &gt; Applicant Actions</b></li> <li><b>Group Actions &gt; Applicant Actions</b></li> </ul>	<ul style="list-style-type: none"> <li>Other Actions menu</li> <li>Group Actions menu</li> </ul>

<b>Action</b>	<b>Search Applicants Page</b>	<b>Manage Applicant Page</b>	<b>Search Applications Page</b>	<b>Manage Application Page</b>	<b>Manage Job Opening Page</b>	<b>Manage Applicant List Page</b>
Add POI (Add Person of Reference)  <hr/> <b>Note:</b> Applicant must be an external applicant who is not already associated with a person of interest (POI) record.	Not available	<b>Other Actions &gt; Applicant Actions</b>	Not available	Not available	Not available	Not available
Change Applicant Status	<ul style="list-style-type: none"> <li>• Actions menu</li> <li>• Group Actions menu</li> </ul>	Toolbar button	<ul style="list-style-type: none"> <li>• <b>Other Actions &gt; Applicant Actions</b></li> <li>• <b>Group Actions &gt; Applicant Actions</b></li> </ul>	<ul style="list-style-type: none"> <li>• <b>Other Actions &gt; Applicant Actions</b></li> <li>• <b>Group Actions &gt; Applicant Actions</b></li> </ul>	<ul style="list-style-type: none"> <li>• <b>Other Actions &gt; Applicant Actions</b></li> <li>• <b>Group Actions &gt; Applicant Actions</b></li> </ul>	<ul style="list-style-type: none"> <li>• Other Actions menu</li> <li>• Group Actions menu</li> </ul>
Copy Salary Package  <hr/> <b>Note:</b> Global Payroll for Australia must be active, the applicant must be in the Hired disposition, the salary package must not have been already copied to HR, and the user must be a recruitment administrator.	Not available	<b>Other Actions &gt; Applicant Actions</b>	<b>Other Actions &gt; Applicant Actions</b>	<b>Other Actions &gt; Applicant Actions</b>	<b>Other Actions &gt; Applicant Actions</b>	Not available
Create Interview Evaluation	Not available	<b>Other Actions &gt; Recruiting Actions</b>	<b>Other Actions &gt; Recruiting Actions</b>	<b>Other Actions &gt; Recruiting Actions</b>	<ul style="list-style-type: none"> <li>• <b>Other Actions &gt; Recruiting Actions</b></li> <li>• <b>Group Actions &gt; Recruiting Actions</b></li> </ul>	Not available



<b>Action</b>	<b>Search Applicants Page</b>	<b>Manage Applicant Page</b>	<b>Search Applications Page</b>	<b>Manage Application Page</b>	<b>Manage Job Opening Page</b>	<b>Manage Applicant List Page</b>
<p>Create Salary Package Model</p> <hr/> <p><b>Note:</b> Global Payroll for Australia must be active and the user must be a recruitment administrator.</p>	<p>Not available</p>	<p><b>Other Actions &gt; Recruiting Actions</b></p>	<p><b>Other Actions &gt; Recruiting Actions</b></p>	<p><b>Other Actions &gt; Recruiting Actions</b></p>	<p><b>Other Actions &gt; Recruiting Actions</b></p>	<p>Not available</p>
<p>Edit Application Details</p>	<ul style="list-style-type: none"> <li>• Actions menu</li> <li>• Group Actions menu</li> </ul> <hr/> <p><b>Note:</b> This action is available only from the keyword search and advanced search.</p>	<ul style="list-style-type: none"> <li>• <b>Other Actions &gt; Recruiting Actions</b></li> <li>• <b>Group Actions &gt; Recruiting Actions</b></li> </ul>	<ul style="list-style-type: none"> <li>• <b>Other Actions &gt; Recruiting Actions</b></li> <li>• <b>Group Actions &gt; Recruiting Actions</b></li> </ul>	<p><b>Other Actions &gt; Recruiting Actions</b></p>	<ul style="list-style-type: none"> <li>• <b>Other Actions &gt; Recruiting Actions</b></li> <li>• <b>Group Actions &gt; Recruiting Actions</b></li> </ul>	<p>Not available</p>
<p>Edit Disposition</p> <hr/> <p><b>Note:</b> If, under a flexible recruiting process, an applicant's current disposition does not have any valid transitions for a particular recruiting role type, then users with that role type do not see the Edit Disposition action for that applicant.</p>	<p>Not available.</p>	<p><b>Other Actions &gt; Recruiting Actions</b></p>	<p><b>Other Actions &gt; Recruiting Actions</b></p>	<p><b>Other Actions &gt; Recruiting Actions</b></p>	<p><b>Other Actions &gt; Recruiting Actions</b></p>	<p>Not available</p>

<b>Action</b>	<b>Search Applicants Page</b>	<b>Manage Applicant Page</b>	<b>Search Applications Page</b>	<b>Manage Application Page</b>	<b>Manage Job Opening Page</b>	<b>Manage Applicant List Page</b>
Forward Applicant	<ul style="list-style-type: none"> <li>• Actions menu</li> <li>• Group Actions menu</li> </ul>	Toolbar button	<ul style="list-style-type: none"> <li>• <b>Other Actions &gt; Applicant Actions</b></li> <li>• <b>Group Actions &gt; Applicant Actions</b></li> </ul>	<ul style="list-style-type: none"> <li>• <b>Other Actions &gt; Applicant Actions</b></li> </ul>	<ul style="list-style-type: none"> <li>• <b>Other Actions &gt; Applicant Actions</b></li> <li>• <b>Group Actions &gt; Applicant Actions</b></li> </ul>	<ul style="list-style-type: none"> <li>• Forward Applicant icon</li> <li>• Group Actions menu</li> </ul>
Invite Application	Icon button  <hr/> <b>Note:</b> This action is available only from the Profile Match, and only when the search matches employees with job openings.	Not available	Not available	Not available	Not available	Not available
Link Applicant to Job	<ul style="list-style-type: none"> <li>• Actions menu</li> <li>• Group Actions menu</li> </ul>	Toolbar button	<ul style="list-style-type: none"> <li>• <b>Other Actions &gt; Applicant Actions</b></li> <li>• <b>Group Actions &gt; Applicant Actions</b></li> </ul>	<ul style="list-style-type: none"> <li>• <b>Other Actions &gt; Applicant Actions</b></li> </ul>	<ul style="list-style-type: none"> <li>• <b>Other Actions &gt; Applicant Actions</b></li> <li>• <b>Group Actions &gt; Applicant Actions</b></li> </ul>	<ul style="list-style-type: none"> <li>• Link to Job Applicant</li> <li>• Group Actions menu</li> </ul>
Manage Applicant Checklists	Not available	<b>Other Actions &gt; Applicant Actions</b>	<b>Other Actions &gt; Applicant Actions</b>	<b>Other Actions &gt; Applicant Actions</b>	<b>Other Actions &gt; Applicant Actions</b>	Not available
Manage Applicant Contracts	Not available  <hr/> <b>Note:</b> This action is not available to users with the Hiring Manager role.	<b>Other Actions &gt; Applicant Actions</b>	<b>Other Actions &gt; Applicant Actions</b>	<b>Other Actions &gt; Applicant Actions</b>	<b>Other Actions &gt; Applicant Actions</b>	Not available
Manage Interviews	Not available	Interview icon	<ul style="list-style-type: none"> <li>• Interview icon</li> <li>• <b>Group Actions &gt; Recruiting Actions</b></li> </ul>	Interview icon	<ul style="list-style-type: none"> <li>• Interview icon</li> <li>• <b>Group Actions &gt; Recruiting Actions</b></li> </ul>	Not available

<b>Action</b>	<b>Search Applicants Page</b>	<b>Manage Applicant Page</b>	<b>Search Applications Page</b>	<b>Manage Application Page</b>	<b>Manage Job Opening Page</b>	<b>Manage Applicant List Page</b>
Mark Reviewed	Not available	<ul style="list-style-type: none"> <li>Mark Reviewed icon</li> <li><b>Group Actions &gt; Recruiting Actions</b></li> </ul>	<ul style="list-style-type: none"> <li>Mark Reviewed icon</li> <li><b>Group Actions &gt; Recruiting Actions</b></li> </ul>	Mark Reviewed icon <b>Recruiting</b>	<ul style="list-style-type: none"> <li>Mark Reviewed icon</li> <li><b>Group Actions &gt; Recruiting Actions</b></li> </ul>	Not available
Merge Applicant  <b>Note:</b> This action is not available to users with the Hiring Manager role.	Not available	Toolbar button	Not available	Not available	<ul style="list-style-type: none"> <li>Available as a group action on the Applicant Activity tab.</li> <li>Available as a button on the Applicant Screening tab: Screening Results section.</li> </ul>	Not available
Pre-Employment Check	Not available	<b>Other Actions &gt; Applicant Actions</b>	<b>Other Actions &gt; Applicant Actions</b>	<b>Other Actions &gt; Applicant Actions</b>	<b>Other Actions &gt; Applicant Actions</b>	Not available
Prepare for Hire  <b>Note:</b> Available only when the disposition is <i>Offer Accepted, Ready to Hire, Hired, or Withdrawn.</i>	Not available	<b>Other Actions &gt; Recruiting Actions</b>	<b>Other Actions &gt; Recruiting Actions</b>	<b>Other Actions &gt; Recruiting Actions</b>	<b>Other Actions &gt; Recruiting Actions</b>	Not available
Prepare Job Offer	Not available	<b>Other Actions &gt; Recruiting Actions</b>	<b>Other Actions &gt; Recruiting Actions</b>	<b>Other Actions &gt; Recruiting Actions</b>	<b>Other Actions &gt; Recruiting Actions</b>	Not available

<b>Action</b>	<b>Search Applicants Page</b>	<b>Manage Applicant Page</b>	<b>Search Applications Page</b>	<b>Manage Application Page</b>	<b>Manage Job Opening Page</b>	<b>Manage Applicant List Page</b>
<p>Print Application Details (individual application) or Print Applications (group action)</p> <hr/> <p><b>Note:</b> This action is also available for individual rows on the <a href="#">Browse Applicants Page</a> and on the <a href="#">My Applicants Pagelet</a> on the Recruiting Home page.</p>	<p>Print icon (all searches except Quick Search)</p>	<ul style="list-style-type: none"> <li>Print icon</li> <li><b>Group Actions &gt; Recruiting Actions</b></li> </ul>	<ul style="list-style-type: none"> <li>Print icon</li> <li><b>Group Actions &gt; Recruiting Actions</b></li> </ul>	<p>Toolbar button</p> <p><b>Recruiting</b></p>	<ul style="list-style-type: none"> <li>Print icon</li> <li><b>Group Actions &gt; Recruiting Actions</b></li> </ul>	<p>Not available</p> <p><b>Recruiting</b></p>
<p>Reject Applicant</p>	<p>Not available</p>	<ul style="list-style-type: none"> <li>Reject icon</li> <li><b>Group Actions &gt; Recruiting Actions</b></li> </ul>	<ul style="list-style-type: none"> <li>Reject icon</li> <li><b>Group Actions &gt; Recruiting Actions</b></li> </ul>	<p>Reject icon</p> <p><b>Recruiting</b></p>	<ul style="list-style-type: none"> <li>Reject icon</li> <li><b>Group Actions &gt; Recruiting Actions</b></li> </ul>	<p>Not available</p> <p><b>Recruiting</b></p>
<p>Reject Offer</p> <hr/> <p><b>Note:</b> An offer in the default (extended) or pending status must exist.</p>	<p>Not available</p>	<p><b>Other Actions &gt; Recruiting Actions</b></p>	<p><b>Other Actions &gt; Recruiting Actions</b></p>	<ul style="list-style-type: none"> <li><b>Other Actions &gt; Recruiting Actions</b></li> <li>Also available as a link on the Interview tab of this page.</li> </ul>	<p><b>Other Actions &gt; Recruiting Actions</b></p>	<p>Not available</p> <p><b>Recruiting</b></p>
<p>Route Applicant</p>	<p>Not available</p>	<ul style="list-style-type: none"> <li>Route icon</li> <li><b>Group Actions &gt; Recruiting Actions</b></li> </ul>	<ul style="list-style-type: none"> <li>Route icon</li> <li><b>Group Actions &gt; Recruiting Actions</b></li> </ul>	<p>Route icon</p> <p><b>Recruiting</b></p>	<ul style="list-style-type: none"> <li>Route icon</li> <li><b>Group Actions &gt; Recruiting Actions</b></li> </ul>	<p>Not available</p> <p><b>Recruiting</b></p>
<p>Send Correspondence</p>	<ul style="list-style-type: none"> <li>Actions menu</li> <li>Group Actions menu</li> </ul>	<ul style="list-style-type: none"> <li><b>Other Actions &gt; Applicant Actions</b></li> <li><b>Group Actions &gt; Applicant Actions</b></li> </ul>	<ul style="list-style-type: none"> <li><b>Other Actions &gt; Applicant Actions</b></li> <li><b>Group Actions &gt; Applicant Actions</b></li> </ul>	<p><b>Other Actions &gt; Applicant Actions</b></p> <p><b>Applicant</b></p>	<ul style="list-style-type: none"> <li><b>Other Actions &gt; Applicant Actions</b></li> <li><b>Group Actions &gt; Applicant Actions</b></li> </ul>	<ul style="list-style-type: none"> <li>Other Actions menu</li> <li>Group Actions menu</li> </ul>

<b>Action</b>	<b>Search Applicants Page</b>	<b>Manage Applicant Page</b>	<b>Search Applications Page</b>	<b>Manage Application Page</b>	<b>Manage Job Opening Page</b>	<b>Manage Applicant List Page</b>
<p>Withdraw Application</p> <hr/> <p><b>Note:</b> Available only when the current disposition has <i>130 Withdrawn Application</i> as a successor disposition.</p> <hr/>	<p>Not available</p>	<ul style="list-style-type: none"> <li>• <b>Other Actions &gt; Recruiting Actions</b></li> <li>• <b>Group Actions &gt; Recruiting Actions</b></li> </ul>	<ul style="list-style-type: none"> <li>• <b>Other Actions &gt; Recruiting Actions</b></li> <li>• <b>Group Actions &gt; Recruiting Actions</b></li> </ul>	<p><b>Other Actions &gt; Recruiting Actions</b></p>	<ul style="list-style-type: none"> <li>• <b>Other Actions &gt; Recruiting Actions</b></li> <li>• <b>Group Actions &gt; Recruiting Actions</b></li> </ul>	<p>Not available</p>
<p>Withdraw from Hire</p> <hr/> <p><b>Note:</b> Available only when the disposition is <i>Ready to Hire</i>, the job opening, if any, is in an <i>Open</i> status, and the data transfer to HR is turned on.</p> <hr/>	<p>Not available</p>	<p><b>Other Actions &gt; Recruiting Actions</b></p>	<p><b>Other Actions &gt; Recruiting Actions</b></p>	<p><b>Other Actions &gt; Recruiting Actions</b></p>	<p><b>Other Actions &gt; Recruiting Actions</b></p>	<p>Not available</p>



# Delivered Workflows for Talent Acquisition Manager

---

## Delivered Workflows for Talent Acquisition Manager

This topic discusses Talent Acquisition Manager workflows. The workflows are listed alphabetically by workflow name.

### Related Links

[Approving Job Openings](#)

[Approving Job Offers](#)

## Job Offer Approval

This section discusses the Job Offer Approval workflow.

### Description

<i>Information Type</i>	<i>Description</i>
Event Description	A hiring manager or recruiter submits a job offer.
Action Description	The system routes the job offer to approvers for approval or denial.
Notification Method	Email and worklist.

### Workflow Objects

<i>Information Type</i>	<i>Description</i>
Event	Launch, Approve
Participant	Approvers
Email Template	JobOfferApproval

<b>Information Type</b>	<b>Description</b>
Business Process	EOAW_APPROVALS
Business Activity	EOAW_ROUTE

## Job Offer Approved

This section discusses the Job Offer Approved workflow.

### Description

<b>Information Type</b>	<b>Description</b>
Event Description	Final approver approves a job offer.
Action Description	The system marks the job offer as approved and notifies the requester.
Notification Method	Email and worklist.

### Workflow Objects

<b>Information Type</b>	<b>Description</b>
Event	OnApprove
Participant	Requester
Email Template	JobOfferApproved
Business Process	EOAW_APPROVALS
Business Activity	EOAW_ROUTE

## Job Offer Deny

This section discusses the Job Offer Deny workflow.



## Description

<i>Information Type</i>	<i>Description</i>
Event Description	An approver denies the job offer.
Action Description	The system marks the job offer as denied, ending the workflow process. The system notifies the requester.
Notification Method	Email and worklist.

## Workflow Objects

<i>Information Type</i>	<i>Description</i>
Event	OnDeny
Participant	Requester
Email Template	JobOfferDeny
Business Process	EOAW_APPROVALS
Business Activity	EOAW_ROUTE

## Job Offer Error

This section discusses the Job Offer Error workflow.

### Description

<i>Information Type</i>	<i>Description</i>
Event Description	An approval workflow error occurred in the approval routing. This can occur as a result of the approval process configuration or because of approval rules or criteria violations.
Action Description	The system routes the job offer to the administrator for resolution.

<i>Information Type</i>	<i>Description</i>
Notification Method	Email and worklist.

## Workflow Objects

<i>Information Type</i>	<i>Description</i>
Event	Error
Participant	Administrator
Email Template	JobOfferError
Business Process	EOAW_APPROVALS
Business Activity	EOAW_ROUTE

## Job Offer Escalation

This section discusses the Job Offer Escalation workflow.

### Description

<i>Information Type</i>	<i>Description</i>
Event Description	An approver has not responded to a job offer within the allotted time.
Action Description	The system notifies the approver and the approver's supervisor and routes the job offer to the next step.
Notification Method	Email and worklist.

### Workflow Objects

<i>Information Type</i>	<i>Description</i>
Event	Escalate

<b>Information Type</b>	<b>Description</b>
Participant	Dynamic
Email Template	JobOfferEscalation
Business Process	EOAW_APPROVALS
Business Activity	EOAW_ROUTE

## Job Offer Review

This section discusses the Job Offer Review workflow.

### Description

<b>Information Type</b>	<b>Description</b>
Event Description	An approver routes the job offer to reviewers to review.
Action Description	The system notifies reviewers that they must review the job offer.
Notification Method	Email and worklist.

### Workflow Objects

<b>Information Type</b>	<b>Description</b>
Event	Review
Participant	Reviewers
Email Template	JobOfferReview
Business Process	EOAW_APPROVALS
Business Activity	EOAW_ROUTE

## Job Offer Termination

This section discusses the Job Offer Termination workflow.

### Description

<i>Information Type</i>	<i>Description</i>
Event Description	A user that has access to the job offer makes a change to a field that might require the job offer to be evaluated again or an administrator overrides the approval process.
Action Description	The system terminates the job offer approval process and notifies the requester.
Notification Method	Email and worklist.

### Workflow Objects

<i>Information Type</i>	<i>Description</i>
Event	Termination
Participant	Requester
Email Template	JobOfferTermination
Business Process	EOAW_APPROVALS
Business Activity	EOAW_ROUTE

### Related Links

[Understanding How to Approve Job Offers](#)

## Job Opening Approval

This section discusses the Job Opening Approval workflow.

## Description

<i>Information Type</i>	<i>Description</i>
Event Description	A hiring manager or recruiter submits a job opening.
Action Description	The system routes the job opening to approvers for approval or denial.
Notification Method	Email and worklist.

## Workflow Objects

<i>Information Type</i>	<i>Description</i>
Event	Approve, Launch
Participant	Approvers
Email Template	JobOpeningApproval
Business Process	EOAW_APPROVALS
Business Activity	EOAW_ROUTE

## Job Opening Approved

This section discusses the Job Opening Approved workflow.

### Description

<i>Information Type</i>	<i>Description</i>
Event Description	Final approver approves a job opening.
Action Description	The system marks the job opening as approved and notifies the requester.
Notification Method	Email and worklist.

## Workflow Objects

<i>Information Type</i>	<i>Description</i>
Event	OnApprove
Participant	Requester
Email Template	JobOpeningApproved
Business Process	EOAW_APPROVALS
Business Activity	EOAW_ROUTE

## Job Opening Deny

This section discusses the Job Opening Deny workflow.

### Description

<i>Information Type</i>	<i>Description</i>
Event Description	An approver denies the job opening.
Action Description	The system marks the job opening as denied, ending the workflow process. The system notifies the requester.
Notification Method	Email and worklist.

## Workflow Objects

<i>Information Type</i>	<i>Description</i>
Event	OnDeny
Participant	Requester
Email Template	JobOpeningDeny
Business Process	EOAW_APPROVALS

<i>Information Type</i>	<i>Description</i>
Business Activity	EOAW_ROUTE

## Job Opening Error

This section discusses the Job Opening Error workflow.

### Description

<i>Information Type</i>	<i>Description</i>
Event Description	An approval workflow error occurred in the approval routing. This can occur as a result of the approval process configuration or because of approval rules or criteria violations.
Action Description	The system routes the job opening to the administrator for resolution.
Notification Method	Email and worklist.

### Workflow Objects

<i>Information Type</i>	<i>Description</i>
Event	Error
Participant	Administrator
Email Template	JobOpeningError
Business Process	EOAW_APPROVALS
Business Activity	EOAW_ROUTE

## Job Opening Escalation

This section discusses the Job Opening Escalation workflow.

## Description

<i>Information Type</i>	<i>Description</i>
Event Description	An approver has not responded to a job opening within the allotted time.
Action Description	The system notifies the approver and the approver's supervisor and routes the job opening to the next step.
Notification Method	Email and worklist.

## Workflow Objects

<i>Information Type</i>	<i>Description</i>
Event	Escalate
Participant	Dynamic
Email Template	JobOpeningEscalation
Business Process	EOAW_APPROVALS
Business Activity	EOAW_ROUTE

## Job Opening Review

This section discusses the Job Opening Review workflow.

### Description

<i>Information Type</i>	<i>Description</i>
Event Description	An approver routes the job opening to reviewers to review.
Action Description	The system notifies reviewers that they must review the job opening.
Notification Method	Email and worklist.



## Workflow Objects

<i>Information Type</i>	<i>Description</i>
Event	Review
Participant	Reviewers
Email Template	JobOpeningReview
Business Process	EOAW_APPROVALS
Business Activity	EOAW_ROUTE

## Job Opening Termination

This section discusses the Job Opening Termination workflow.

### Description

<i>Information Type</i>	<i>Description</i>
Event Description	A user that has access to the job opening makes a change to a field that might require the job opening to be evaluated again or an administrator overrides the approval process.
Action Description	The system terminates the job opening approval process and notifies the requester.
Notification Method	Email and worklist.

## Workflow Objects

<i>Information Type</i>	<i>Description</i>
Event	Termination
Participant	Requester
Email Template	JobOpeningTermination

<b>Information Type</b>	<b>Description</b>
Business Process	EOAW_APPROVALS
Business Activity	EOAW_ROUTE

## Related Links

[Understanding How to Approve Job Openings](#)

---

## Delivered Notification Templates

This topic lists notification templates that are used in PeopleSoft Recruiting. All templates are defined as PeopleTools generic templates. To access the template definitions, select **PeopleTools > Workflow > Notifications > Generic Templates**.

### Approval Notification Templates

This table lists the delivered notification templates for Talent Acquisition Manager approval processing.

<b>Template Name</b>	<b>Description</b>
JobOfferApproval	Job Offer Approval Routing
JobOfferApproved	Job Offer Has Been Approved
JobOfferDeny	Job Offer Has Been Denied
JobOfferError	Job Offer Error
JobOfferEscalation	Job Offer Escalation
JobOfferReview	Job Offer Review
JobOfferTermination	Job Offer Termination
JobOpeningApproval	Job Opening Approval Routing
JobOpeningApproved	Job Opening Has Been Approved
JobOpeningDeny	Job Opening Has Been Denied

<b>Template Name</b>	<b>Description</b>
JobOpeningError	Job Opening Error
JobOpeningEscalation	Job Opening Escalation
JobOpeningReview	Job Opening Review
JobOpeningTermination	Job Opening Termination

## General Notification Templates

This table lists delivered notification templates other than the templates that are used for approval-related notifications.

<b>Template Name</b>	<b>Description</b>
ApplicantStsEffect	Applicant Status Change
AutomatchNotification	Recruiter Job Opening Notify
HRS_APPLICATION_PASSWORD	Applicant Password/User IDs
HRS_APP_ACCT_LOCK	Mail text for account lock.
HRS_APP_CONS_RTE	Consolidated Route Email
HRS_APP_PERM_ACT_LOCK	Mail texts for account lock.
HRS_APP_PSWD_CHANGE	Applicant Password change
HRS_APP_RTE	Applicants Route Notification
HRS_APP_RTE_NOJOB	Application Route - No Job
HRS_APP_RTE_NORCMNT	Application Route - No Rcmt ID This notification is no longer used.
HRS_APP_SECRET_ATTEMPT	Mail text for secret question.

<b>Template Name</b>	<b>Description</b>
HRS_ARM_GENERICRESEND	Send Correspondence Resend
HRS_BATCH_NOTIFY	Notification Error Template
HRS_CE_APPL_APPLY_JOB	Submit resume notification
HRS_CE_EML_FRND	Email a Friend
HRS_EMPL_CNFRM_REF	Employee Confirm Referral
HRS_EMPL_NOTIF_REF	Employee Notify Referral
HRS_EVAL_ASGN	Evaluator Assigned to Job Open
HRS_EVAL_REMOVE	Remove Evaluator Notification
HRS_FORWARD_APPLICANT	Forward Applicant
HRS_HROI_DRAFT	Notify on Draft Status
HRS_HROI_REJECT	Notify on Reject
HRS_HROI_SUCCESS	Notify on Success
HRS_HROI_UNRESOLVED	Notification sent on Unresolved
HRS_ICALENDAR_NOTIFY	iCalendar Notification
HRS_INTVWSCHED_APPL	Notify Interview Applicant
HRS_INTVWSCHED_APPL_NOJO	NotifyInterviewApplicant
HRS_INTVWSCHED_NOJO_CANCEL	NotifyCancelledIntTeamnojo
HRS_INTVWSCHED_TEAM_CANCEL	NotifyCancelledInterviewTeam
HRS_INTVW_APP_CANCEL	Notify Interview Cancellation

<b>Template Name</b>	<b>Description</b>
HRS_INTVW_CANCEL_APP_NOJO	Notify Interview Cancellation
HRS_INTVW_EVAL_RMNDR	Interview Evaluation Reminder
HRS_INTVW_NOJO_NOTIFY_CALINTG	Notify Interview Team
HRS_INTVW_NOTIFY_CALINTG	NotifyInterviewTeam
HRS_INTVW_SCHED_TEAM	Notify Interview Team
HRS_INTVW_SCHED_TEAM_NOJO	Notify Interview Team
HRS_INT_CUSTOMIZE_MSG	Customize Message Request
HRS_INT_EVAL_DELETE_RETURN	Interview Evaluation Return
HRS_INT_EVAL_SUBMIT	Interview Evaluation Submit
HRS_INT_GEN_MTG_RQST	GeneralMeetingRequest
HRS_INVITE_APPLICATION	Invite Employee to Apply
HRS_LINK_APPJO	Link Applicant to JO
HRS_NOTIFY_RECRUITERS	Send email to recruiters
HRS_OFFER_DOC_ATCH	Offer Doc Attachment Notice
HRS_OFFER_NOTICE	Online Job Offer Notice
HRS_OFFER_RESPONSE	Online Job Offer Response
HRS_QSTN_REQUEST	Questionnaire Request
HRS_RTE_RSPN	Route Response Notification.
HRS_RTE_RSPNS_RMNDR	Route Response Reminder Email

<b>Template Name</b>	<b>Description</b>
HRS_RTE_RSPN_NOJOB	Route Response Notification.
HRS_SEND_CRSP_GEN_EML	Generic Correspondence
HRS_SEND_EVAL	Send Email to Evaluators
HRS_UNEVAL_ANS	Unevaluated Answers
HRS_UPDATE_REFERENCES	Applicant References
HR_ERR_NOTIF	Hire Error Notification Template
HR_HIRE_NOTIF	Hire Notification template
JobAgentNotification	Applicant Job Agent Notify
JobOpeningStsEffct	Job Opening Status Change
OtherStsEffct	Status Change

## Message Catalog and Text Catalog Entries in Notifications

This table identifies template variables that reference entries in either the message catalog or the text catalog. Use this information when you want to modify a notification template and you need to locate the source of the notification text.

<b>Template ID (Description)</b>	<b>Variable References</b>
AutomatchNotification (Recruiter Job Opening Notify)	<p>Message Catalog:</p> <ol style="list-style-type: none"> <li>1. 1117, 1021 message text provides the notification subject (variable %1).</li> <li>2. 1117, 1021 message description provides the notification body text (variable %2).</li> </ol>

<b>Template ID (Description)</b>	<b>Variable References</b>
HRS_APP_ACCT_LOCK (Mail text for account lock)	<p>Message Catalog:</p> <ol style="list-style-type: none"> <li>1. 1117, 17029 message text provides the notification subject (variable %1).</li> <li>2. 1117, 17029 message description provides the notification body text (variable %2).</li> </ol>
HRS_APP_PERM_ACT_LOCK (Mail texts for account lock)	<p>Message Catalog:</p> <ol style="list-style-type: none"> <li>1. 18178, 61 message text provides the notification subject (variable %1).</li> <li>2. 18178, 61 message description provides the notification body text (variable %2).</li> </ol>
HRS_APP_PSWD_CHANGE (Applicant Password change)	<p>Message Catalog:</p> <ol style="list-style-type: none"> <li>1. 1117, 17028 message text provides the notification subject (variable %1).</li> <li>2. 1117, 17028 message description provides the notification body text (variable %2).</li> </ol>
HRS_APP_SECRET_ATTEMPT (Mail text for secret question)	<p>Message Catalog:</p> <ol style="list-style-type: none"> <li>1. 18178, 59 message text provides the notification subject (variable %1).</li> <li>2. 18178, 59 message description provides the first line of the notification body text, which states that the secret question was answered incorrectly (in variable %2).</li> <li>3. 18178, 60 message text provides the next line of the notification body text, which says how many attempts are left before lockout (in variable %2).</li> </ol>
HRS_APPLICANT_PASSWORD (Applicant Password/User IDs)	<p>Message Catalog for forgot password notification:</p> <ol style="list-style-type: none"> <li>1. 1117, 927 message text provides the notification subject (variable %1).</li> <li>2. 1117, 927 message description provides the notification body text (variable %2).</li> </ol> <p>Message Catalog for forgot user name notification:</p> <ol style="list-style-type: none"> <li>1. 18178, 254 message text provides the notification subject (variable %1).</li> <li>2. 18178, 254 message description provides the notification body text (variable %2).</li> </ol>

<b>Template ID (Description)</b>	<b>Variable References</b>
<p>HRS_BATCH_NOTIFY</p> <p>(Notification Error Template)</p>	<p>Message Catalog:</p> <ol style="list-style-type: none"> <li>1. 18177, 2996 message text provides the notification subject (variable %1).</li> <li>2. 18177, 2996 message description provides the notification body text (variable %2).</li> </ol>
<p>HRS_CE_APPL_APPLY_JOB</p> <p>(Submit resume notification)</p>	<p>Text Catalog:</p> <p>These entries are used when an applicant submits a job application:</p> <ol style="list-style-type: none"> <li>1. HRAM_CENOTIF_SUBJ1 provides the notification subject (variable %1).</li> <li>2. HRAM_CENOTIF_BODY1 provides the notification body text (variable %2) when an applicant applies with a job.</li> <li>3. HRAM_CENOTIF_BODY2 provides the notification body text (variable %2) when an applicant applies without a job.</li> </ol> <p>These entries are used when applications are submitted using the Refer a Friend process (the notification is sent to the friend):</p> <ol style="list-style-type: none"> <li>1. HRAM_RENOTIF_SUBJ1 provides the notification subject (variable %1).</li> <li>2. HRAM_RENOTIF_BODY1 provides the notification body text (variable %2) when an applicant applies with a job.</li> <li>3. HRAM_RENOTIF_BODY2 provides the notification body text (variable %2) when an applicant applies without a job.</li> </ol>
<p>HRS_CE_EML_FRND</p> <p>(Email a Friend)</p>	<p>Text Catalog:</p> <ol style="list-style-type: none"> <li>1. HRAM_CEEMLFND_SUB1 provides the notification subject (variable %1).</li> <li>2. HRAM_CEEMLFND_BOD1 provides the notification body text (variable %2).</li> </ol>



<b>Template ID (Description)</b>	<b>Variable References</b>
<p>HRS_ICALENDAR_NOTIFY (iCalendar Notification)</p>	<p>Message Catalog:</p> <ol style="list-style-type: none"> <li>1. 18177, 2771 provides the notification subject (variable %1) when the interview is associated with a job opening.</li> <li>2. 18177, 2800 provides the notification subject (variable %1) when the interview is not associated with a job opening.</li> <li>3. 18177, 2772 provides the notification body text (variable %2) regardless of whether the interview is associated with a job opening.</li> </ol>
<p>HRS_INVITE_APPLICATION (Invite Employee to Apply)</p>	<p>Message Catalog:</p> <ol style="list-style-type: none"> <li>1. 18177, 2730 provides the notification subject (variable %1).</li> <li>2. 18177, 2731 provides the notification body text (variable %2).</li> </ol>
<p>HRS_UPDATE_REFERENCES (Applicant References)</p>	<p>Message Catalog:</p> <ol style="list-style-type: none"> <li>1. 18032, 863 provides the notification subject (variable %1).</li> <li>2. 18032, 1793 provides the notification body text (variable %2) when the applicant already has a Candidate Gateway account.</li> <li>3. 18032, 864 provides the notification body text (variable %2) when the applicant does not have a Candidate Gateway account.</li> </ol>
<p>JobAgentNotification (Applicant Job Agent Notify)</p>	<p>Message Catalog:</p> <ol style="list-style-type: none"> <li>1. 1117, 9212 message text provides the notification subject (variable %1).</li> <li>2. 1117, 9212 message description provides the notification body text (variable %2). It reference additional message catalog text: <ol style="list-style-type: none"> <li>a. 1117, 9213 lists the jobs that meet the applicant’s search criteria.</li> <li>b. 1117, 9214 appears if there are too many jobs to list. It instructs the applicant to view the full list in Candidate Gateway.</li> <li>c. 1117, 9032 provides the closing section of the notification body text.</li> <li>d. 1117, 17027 is part of the closing section of the notification body text.</li> </ol> </li> </ol>

<b>Template ID (Description)</b>	<b>Variable References</b>
<p>HRS_HROI_DRAFT</p> <p>(Notify on Draft Status)</p>	<p>Message Catalog:</p> <ol style="list-style-type: none"> <li>1. 18179, 175 provides the instructions in the body text (variable %3) when the notification recipient has a Candidate Gateway account that is linked to an applicant record</li> <li>2. 18179, 176 provides the instructions in the body text (variable %3) when the notification recipient has a Candidate Gateway account that is not linked to an applicant record</li> <li>3. 18179, 175 provides the instructions in the body text (variable %3) when the notification recipient does not have a Candidate Gateway account.</li> </ol>
<p>HRS_HROI_REJECT</p> <p>(Notify on Reject)</p>	<p>Message Catalog:</p> <ol style="list-style-type: none"> <li>1. 18179, 175 provides the instructions in the body text (variable %3) when the notification recipient has a Candidate Gateway account that is linked to an applicant record</li> <li>2. 18179, 176 provides the instructions in the body text (variable %3) when the notification recipient has a Candidate Gateway account that is not linked to an applicant record</li> <li>3. 18179, 175 provides the instructions in the body text (variable %3) when the notification recipient does not have a Candidate Gateway account.</li> </ol>
<p>HRS_HROI_SUCCESS</p> <p>(Notify on Success)</p>	<p>Message Catalog:</p> <ol style="list-style-type: none"> <li>1. 18179, 175 provides the instructions in the body text (variable %3) when the notification recipient has a Candidate Gateway account that is linked to an applicant record</li> <li>2. 18179, 176 provides the instructions in the body text (variable %3) when the notification recipient has a Candidate Gateway account that is not linked to an applicant record</li> <li>3. 18179, 175 provides the instructions in the body text (variable %3) when the notification recipient does not have a Candidate Gateway account.</li> </ol>

<b>Template ID (Description)</b>	<b>Variable References</b>
HRS_HROI_UNRESOLVED  (Notification sent on Unresolved)	Message Catalog:  1. 18179, 175 provides the instructions in the body text (variable %3) when the notification recipient has a Candidate Gateway account that is linked to an applicant record  2. 18179, 176 provides the instructions in the body text (variable %3) when the notification recipient has a Candidate Gateway account that is not linked to an applicant record  3. 18179, 175 provides the instructions in the body text (variable %3) when the notification recipient does not have a Candidate Gateway account.



# Delivered Permission Lists and Roles for Talent Acquisition Manager

---

## Delivered Permission Lists and Roles

This topic provides summary information about the delivered roles and permission lists for PeopleSoft Recruiting Solutions. Roles and permission lists are part of standard PeopleTools security administration, used to grant access to components and pages. Roles and permission lists are discussed in the *PeopleTools: Security Administration* documentation.

By associating standard PeopleTools roles with *recruiting role types*, you can grant users additional recruiting-specific privileges. This topic does not discuss recruiting role types. For more information, see [Understanding Recruiting Security](#).

### Delivered Recruiting Roles

Oracle delivers these roles for recruiting:

- Recruitment Administrator

Administrators have access to all Talent Acquisition Manager pages. By associating this role with the *Recruitment Administrator* recruiting role type, you also give users with this role additional privileges that are controlled programmatically rather than through permission lists.

See [Recruiting Privileges Granted Through Recruiting Role Types](#).

- Recruitment User
- Recruiter
- Federal Recruiter
- Recruiting Manager
- Hiring Manger
- RS Technical Administrator
- RS Approval Administrator
- Applicant and Internal Applicant Fluid

These roles are for internal applicants. The *Applicant* role provides access to classic Candidate Gateway. The *Internal Applicant Fluid* role provides access to Fluid Candidate Gateway.

- External Applicant and External Applicant Fluid

These roles are for external applicants. The *External Applicant* role provides access to classic Candidate Gateway. The *External Applicant Fluid* provides access to Fluid Candidate Gateway.

---

**Note:** Oracle recommends that applicants have either the role for Fluid Candidate Gateway or the role for classic Candidate Gateway, but not both. See “Understanding Access to Candidate Gateway” (PeopleSoft Candidate Gateway).

---

## Delivered Recruiting Permission Lists

The following table lists the delivered permission lists for recruiting and indicates which of the roles are delivered with access to each list.

<b>Permission List ID and Name</b>	<b>Recruitment Administrator?</b>	<b>Recruiter and Recruiting Manager?</b>	<b>Hiring Manager?</b>	<b>Additional Roles?</b>
HCCIRS0000 Recruiting Solutions- Comp Intf				Recruitment User  Applicant  Internal Applicant Fluid
HCCIRS1000 Set Up Recruit Soln- Comp Intfc	Yes			
HCCPRS0000 Recruiting Solutions Hidden				Recruitment User
HCCPRS1000 Set Up Recruiting Solutions	Yes			
HCCPRS1010 Set Up RS Integrations	Yes			RS Technical Administrator
HCCPRS1020 Set Up Approvals	Yes			RS Approval Administrator

<b>Permission List ID and Name</b>	<b>Recruitment Administrator?</b>	<b>Recruiter and Recruiting Manager?</b>	<b>Hiring Manager?</b>	<b>Additional Roles?</b>
HCCPRS1030 Candidate Management	Yes	Yes		
HCCPRS1040 Job Opening Management	Yes	Yes	Yes	
HCCPRS1050 RS Applicant Self-Service				Applicant
HCCPRS1060 RS Applicant List	Yes	Yes	Yes	
HCCPRS1070 (USF) Recruiting Solutions Federal				Federal Recruiter
HCCPRS1080 Works Council	Yes			
HCCPRS1090 RS Reports	Yes	Yes	Yes	
HCCPRS1100 External Applicant				External Applicant
HCCPRS1110 Recruitment Referrals	Yes			
HCCPRS1120 Employee Recruitment				Employee

<b><i>Permission List ID and Name</i></b>	<b><i>Recruitment Administrator?</i></b>	<b><i>Recruiter and Recruiting Manager?</i></b>	<b><i>Hiring Manager?</i></b>	<b><i>Additional Roles?</i></b>
HCCPRS1130 Recruiting Solutions Pagelets	Yes	Yes	Yes	
HCCPRS1140 Recruiting Teams	Yes			
HCCPRS1150 Resume Management	Yes	Yes		
HCCPRS1160 RS Technical Utilities	Yes			RS Technical Administrator
HCCPRS1170 Interviews	Yes	Yes	Yes	
HCCPRS1175 Evaluators for Open Ended Questions				Evaluator for Open Ended Quest
HCCPRS1180 Manage Interviews	Yes	Yes		
HCCPRS1190 RS Salary Package Model	Yes			
HCCPRS1200 RS Saved Searches	Yes	Yes		
HCCPRS1210 Checklists	Yes			



<b><i>Permission List ID and Name</i></b>	<b><i>Recruitment Administrator?</i></b>	<b><i>Recruiter and Recruiting Manager?</i></b>	<b><i>Hiring Manager?</i></b>	<b><i>Additional Roles?</i></b>
HCCPRS1220 RS Prepare for Hire	Yes	Yes	Yes	
HCCPRS1230 RS Contracts	Yes	Yes	Yes	
HCCPRS1240 RS Send Correspondence	Yes	Yes	Yes	
HCCPRS1250 RS Candidate Data Full Access	Yes	Yes		
HCCPRS1260 RS Candidate Data Restricted			Yes	
HCCPRS1270 JO from Position Creation	Yes			
HCCPRS1280 Manage Duplicate Applicants	Yes			
HCCPRS1300 Recruiting Home	Yes	Yes	Yes	
HCCPRS1310 Recruiting Manager		Recruiting Manager, but not Recruiter		
HCCPRS1320 RS Job Posting Appl Search		Yes	Yes	Applicant Internal Applicant Fluid

<b><i>Permission List ID and Name</i></b>	<b><i>Recruitment Administrator?</i></b>	<b><i>Recruiter and Recruiting Manager?</i></b>	<b><i>Hiring Manager?</i></b>	<b><i>Additional Roles?</i></b>
HCCPRS1321 RS Applicant Global Search	Yes	Yes		
HCCPRS2000 Internal Applicant Fluid				Internal Applicant Fluid
HCCPRS2100 External Applicant Fluid				External Applicant Fluid
HCSPRS9020 RS Standard Message Channels				Recruitment User
HCSPRS9030 RS Web Libraries				Recruitment User
HCSPRS9040 RS Standard CIs	Yes			RS Technical Administrator
HCCPHR9600 Applicant ID Delete permission				No role is delivered by Oracle with this permission list. You can add this permission list to any role as per your organization's requirement.

<b><i>Permission List ID and Name</i></b>	<b><i>Recruitment Administrator?</i></b>	<b><i>Recruiter and Recruiting Manager?</i></b>	<b><i>Hiring Manager?</i></b>	<b><i>Additional Roles?</i></b>
Additional non-recruiting permission lists	HCCPWF2000 (Worklist)  HCSPWEBLIB (Standard WebLib Permissions)	HCCPSCAW1020 (AWE Manager Permissions)	HCCPSCAW1020 (AWE Manager Permissions)	Applicant and Internal Applicant Fluid roles are also associated with HCSPWEBLIB (Standard WebLib Permissions)  External Applicant and External Applicant Fluid roles are also associated with HCSPWEBLIB (Standard WebLib Permissions)  Recruitment User role is also associated with HCSPSERVICE (Standard Service security)



# PeopleSoft Talent Acquisition Manager Reports

## Talent Acquisition Manager Reports: A to Z

The table in this topic lists PeopleSoft Talent Acquisition Manager reports, sorted by report ID.

For more information about running these reports, refer to:

- The corresponding topic in this product documentation.
- *PeopleTools: Process Scheduler*
- *PeopleTools: BI Publisher for PeopleSoft*
- *PeopleTools: SQR Language Reference for PeopleSoft*

For samples of these reports, see the [Report Samples](#) that are published with the online documentation.

<b>Report ID and Report Name</b>	<b>Description</b>	<b>Navigation</b>	<b>Run Control Page</b>
HRS001 Adverse Impact Analysis	<p>Analyzes information on recruitment and hiring practices. (SQR) This report does not support languages other than the base language.</p> <hr/> <p><b>Note:</b> The Adverse Impact includes only applicants for whom name, gender, and ethnicity data is available. Additionally, the <b>Eligible to Work in the US</b> check box must be selected on the application, and the application must have been through a standard screening process (not prescreening or online screening) and had the screening results applied.</p> <hr/> <p>See “Understanding Adverse Impact Reporting Requirements” (PeopleSoft Human Resources Meet Regulatory Requirements).</p>	<b>Recruiting &gt; Reports &gt; Adverse Impact (USA) &gt; Adverse Impact Analysis</b>	RUN_CNTL_REG_INTRO

<b>Report ID and Report Name</b>	<b>Description</b>	<b>Navigation</b>	<b>Run Control Page</b>
HRS001UK Adverse Impact (UK)	Lists job offers and applications by ethnic groups and gender. (SQR)	<b>Recruiting &gt; Reports &gt; Adverse Impact (UK) &gt; Adverse Impact (UK)</b>	RUNCTL_FROMTHRU
HRS002 Job Group Movement Analysis	<p>Provides racial and gender demographic data regarding your hiring process. (SQR)</p> <p>This report provides an analysis of the number of males and females by ethnic group who were applicants, hires, promotions, or terminations during a specified time period. The report shows which sex and ethnic groups are moving in and out of the organization and which groups are offered opportunities for advancement.</p> <p>This report does not support languages other than the Base Language</p> <hr/> <p><b>Note:</b> The Job Group Movement Analysis report includes only applicants for whom name, gender, and ethnicity data is available. Additionally, for sections other than promotions and terminations, the report considers only applicants who have had results applied from a standard screening process (not prescreening or online screening) and for whom the <b>Eligible to Work in the US</b> check box is selected on the application.</p> <hr/>	<b>Recruiting &gt; Reports &gt; Job Group Movement Analysis &gt; Job Group Movement Analysis</b>	RUN_CNTL_REG_INTRO
HRS003 Job Opening Status Listing	For each job opening, the report lists job information, job opening status, recruiter, the number of applicants, and expenses information. (SQR)	<b>Recruiting &gt; Reports &gt; Job Opening Status &gt; Job Opening Status</b>	PRCSRUNCNTL

<b>Report ID and Report Name</b>	<b>Description</b>	<b>Navigation</b>	<b>Run Control Page</b>
HRS005 Applicant Listing	This report combines job opening information with a list of candidates being interviewed for the position. It groups requisitions by Department ID. For each candidate interviewed, the report displays the following: employee ID, name, status in the interview process (active, inactive, hired, withdrawn), last interview step completed, and any offers made. (SQR)	<b>Recruiting &gt; Reports &gt; Applicant Listing &gt; Applicant Listing</b>	PRCSRUNCNTL_LC_HR
HRS006 Job Opening Cost Analysis	Provides a breakdown of expense types and amounts for each job opening. (SQR)  For each job opening, the report lists the job opening number, job code, position number, status, title of the position offered, and the recruiter's name. The last two columns contain a breakdown of each type of expense incurred and its monetary amount, including a total by job opening number. A department summary includes an expense total for all job openings, each expense category, and calculates a department-average cost-per-hire amount.	<b>Recruiting &gt; Reports &gt; Job Opening Cost Analysis &gt; Job Opening Cost Analysis</b>	PRCSRUNCNTL
HRS007 Salary Package Model	Lists applicant salary package models. (SQR)	<b>Recruiting &gt; Reports &gt; Salary Package Model &gt; Salary Package Model</b>	HRS_RUN_PKG004_APP
HRS010 Vacant Budgeted Positions	Lists all vacant budgeted positions. (SQR)	<b>Recruiting &gt; Reports &gt; Vacant Budgeted Positions &gt; Vacant Budgeted Positions</b>	RUN_HRS010
HRS011 Applicant Summary by Job	For each job opening, this report lists the number and percentage of applicants by referral source. (SQR)	<b>Recruiting &gt; Reports &gt; Applicant Summary by Job &gt; Applicant Summary by Job</b>	PRCSRUNCNTL_LC_HR

<b>Report ID and Report Name</b>	<b>Description</b>	<b>Navigation</b>	<b>Run Control Page</b>
HRS012 Applicant Summary by Source	Lists the number and percentage of applicants by source type. (SQR)	<b>Recruiting &gt; Reports &gt; Applicant Summary by Source &gt; Applicant Summary by Source</b>	PRCSRUNCNTL_LC_HR
HRS013 Works Council Posting	List open job openings monitored by a Works Council. (SQR)	<b>Recruiting &gt; Reports &gt; Works Council Posting &gt; Works Council Posting</b>	HRS_RUN_APP013
HRS014 Job Posting	Shows detailed posting information for a job opening. (SQR)	<b>Recruiting &gt; Reports &gt; Job Posting &gt; Job Posting</b>	HRS_RUN_APP014
HRS032 Full Text Vacancy Report	Generates a hard copy of the full vacancy announcement. (SQR)	<b>Recruiting &gt; Reports &gt; Full Text Vacancy Report &gt; Full Text Vacancy</b>	RUN_HRS032
HRS034 Job Code and Position Audit	Cross references position numbers and job codes. (SQR)	<b>Recruiting &gt; Reports &gt; Job Code &amp; Position Audit &gt; Job Code &amp; Position Audit</b>	RUNCTL_FGASOFDT
HRS035 Application Analysis (USA)	Analyze information on recruitment and hiring practices. (SQR)  This report excludes applications for applicants whose applicant status is <i>030 Inactive</i> .  If you specify a <b>From Date</b> and <b>Thru Date</b> , the report includes only applications where the disposition status date falls within the specified date range.	<b>Recruiting &gt; Reports &gt; Application Analysis (USA) &gt; Application Analysis (USA)</b>	RUN_CNTL_HRS035
HRS037 Pre-Screening Activity Report	List applicants who have been pre-screened during the online application process, and show each applicant's pre-screening results and disposition. (SQR)	<b>Recruiting &gt; Reports &gt; Pre-Screening Activity Report &gt; Pre-Screening Activity Report</b>	HRS_RUN_HRS037
HRS816 Priority Placement Table (USF)	List the valid priority placement values. (BI Publisher)	<b>Recruiting &gt; Reports &gt; Priority Placement Table &gt; Priority Placement Table</b>	PRCSRUNCNTL



<b>Report ID and Report Name</b>	<b>Description</b>	<b>Navigation</b>	<b>Run Control Page</b>
HRS820; HRS82B, HRS82C Candidate Evaluations List (USF)	Produces an Evaluation of Candidate reports. The three different versions of the report display the same information using different sorting rules. HRS820 sorts by applicant ID, HRS82B sorts by applicant name, and HRS83C sorts by score. (BI Publisher)	<b>Recruiting &gt; Reports &gt; Candidate Evaluations List &gt; Candidate Evaluations List</b>	HRS_RUN_HRS820
HRS821 Certificate of Eligibles (USF)	Generates a Certificate of Eligibles report. (BI Publisher)	<b>Recruiting &gt; Reports &gt; Run Certificate of Eligibles &gt; Certificate of Eligibles</b>	HRS_RUN_HRS821
HRS_APP_LET Applicant Letters	Includes general-purpose letters that users can send to applicants. This report definition includes multiple templates. Users select a single template when generating a letter. (BI Publisher)	Users can choose applicant letters on these pages: <ul style="list-style-type: none"> <li>• <a href="#">Application Details Page</a></li> <li>• <a href="#">Send Correspondence Page</a></li> <li>• <a href="#">Job Opening - Screening Criteria Page</a></li> </ul> Refer to the documentation for each page to learn how the letters are generated.	n/a
HRS_BIP_APPL Application Details	Prints detailed information about an applicant's job application. (BI Publisher)	To create this report for a single application, Click the Generate Report button on the <a href="#">Application Report Options Page</a> .  To create this report for multiple applications, click the Run button on the <a href="#">Print Applications Page</a> .	HRS_RUN_BTCH_APPL for a multi-application report.  For a single application, there is no run control page because the system creates and opens the report immediately from the Application Report Options page.
HRS_BIP_INTS Interview Summary	Prints a complete list of interviews for a single job opening. For each applicant who has a scheduled interview, the report lists the interview date, time, location, and interviewers. (BI Publisher)	Click the Print Interviews toolbar button on the <a href="#">Interview Summary Page</a> .	n/a

<b>Report ID and Report Name</b>	<b>Description</b>	<b>Navigation</b>	<b>Run Control Page</b>
HRS_BIP_JOB Job Opening Report	Prints detailed information about a single job opening, including job opening details, notes, expenses, status history, and applicant summary information. (BI Publisher)	Click the Print Job Opening toolbar button on the <a href="#">Job Opening Page</a> or the <a href="#">Manage Job Opening Page</a> .	n/a
HRS_INT_LET Interview Letters	Includes interview-related letters that users can send to applicants. This report definition includes multiple templates. Users select a single template when generating a letter. (BI Publisher)	Users can choose and generate an interview letter on the <a href="#">Interview Schedule Page</a> .	n/a
HRS_OFF_LET Offer Letters	Includes offer-related letters that users can send to applicants. This report definition includes multiple templates. Users select a single template when generating a letter. (BI Publisher)	Users can choose and generate an offer letter on the <a href="#">Prepare Job Offer Page</a> .	n/a