PeopleTools 8.62: Workflow Technology

April 2025

This software and related documentation are provided under a license agreement containing restrictions on use and disclosure and are protected by intellectual property laws. Except as expressly permitted in your license agreement or allowed by law, you may not use, copy, reproduce, translate, broadcast, modify, license, transmit, distribute, exhibit, perform, publish, or display any part, in any form, or by any means. Reverse engineering, disassembly, or decompilation of this software, unless required by law for interoperability, is prohibited.

The information contained herein is subject to change without notice and is not warranted to be error-free. If you find any errors, please report them to us in writing.

If this is software, software documentation, data (as defined in the Federal Acquisition Regulation), or related documentation that is delivered to the U.S. Government or anyone licensing it on behalf of the U.S. Government, then the following notice is applicable:

U.S. GOVERNMENT END USERS: Oracle programs (including any operating system, integrated software, any programs embedded, installed, or activated on delivered hardware, and modifications of such programs) and Oracle computer documentation or other Oracle data delivered to or accessed by U.S. Government end users are "commercial computer software," "commercial computer software documentation," or "limited rights data" pursuant to the applicable Federal Acquisition Regulation and agency-specific supplemental regulations. As such, the use, reproduction, duplication, release, display, disclosure, modification, preparation of derivative works, and/or adaptation of i) Oracle programs (including any operating system, integrated software, any programs embedded, installed, or activated on delivered hardware, and modifications of such programs), ii) Oracle computer documentation and/or iii) other Oracle data, is subject to the rights and limitations specified in the license contained in the applicable contract. The terms governing the U.S. Government's use of Oracle cloud services are defined by the applicable contract for such services. No other rights are granted to the U.S. Government.

This software or hardware is developed for general use in a variety of information management applications. It is not developed or intended for use in any inherently dangerous applications, including applications that may create a risk of personal injury. If you use this software or hardware in dangerous applications, then you shall be responsible to take all appropriate fail-safe, backup, redundancy, and other measures to ensure its safe use. Oracle Corporation and its affiliates disclaim any liability for any damages caused by use of this software or hardware in dangerous applications.

Oracle®, Java, MySQL, and NetSuite are registered trademarks of Oracle and/or its affiliates. Other names may be trademarks of their respective owners.

Intel and Intel Inside are trademarks or registered trademarks of Intel Corporation. All SPARC trademarks are used under license and are trademarks or registered trademarks of SPARC International, Inc. AMD, Epyc, and the AMD logo are trademarks or registered trademarks of Advanced Micro Devices. UNIX is a registered trademark of The Open Group.

This software or hardware and documentation may provide access to or information about content, products, and services from third parties. Oracle Corporation and its affiliates are not responsible for and expressly disclaim all warranties of any kind with respect to third-party content, products, and services unless otherwise set forth in an applicable agreement between you and Oracle. Oracle Corporation and its affiliates will not be responsible for any loss, costs, or damages incurred due to your access to or use of third-party content, products, or services, except as set forth in an applicable agreement between you and Oracle.

Documentation Accessibility

For information about Oracle's commitment to accessibility, visit the Oracle Accessibility Program website at <https://docs.oracle.com/pls/topic/lookup?ctx=acc&id=docacc>.

Access to Oracle Support

Oracle customers that have purchased support have access to electronic support through My Oracle Support. For information, visit <https://docs.oracle.com/pls/topic/lookup?ctx=acc&id=info> or visit <https://docs.oracle.com/pls/topic/lookup?ctx=acc&id=trs> if you are hearing impaired.

Contents

- Preface: Preface.....ix**
- Understanding the PeopleSoft Online Help and PeopleBooks..... ix
- Hosted PeopleSoft Online Help..... ix
- Locally Installed PeopleSoft Online Help..... ix
- Downloadable PeopleBook PDF Files.....ix
- Common Help Documentation.....ix
- Field and Control Definitions..... x
- Typographical Conventions..... x
- ISO Country and Currency Codes..... xi
- Region and Industry Identifiers..... xi
- Translations and Embedded Help..... xii
- Using and Managing the PeopleSoft Online Help..... xii
- PeopleTools Related Links..... xii
- Contact Us..... xii
- Follow Us..... xiii
- Chapter 1: Getting Started with PeopleSoft Workflow Technology.....15**
- PeopleSoft Workflow Technology Overview..... 15
- PeopleSoft Workflow Technology Implementation..... 15
- Chapter 2: Understanding PeopleSoft Workflow..... 19**
- Understanding PeopleSoft Workflow..... 19
- Understanding Workflow Tools..... 19
- Workflow Tools..... 19
- Work Items..... 20
- Workflow Triggers..... 20
- Understanding Workflow Application Development..... 20
- Rules..... 20
- Roles..... 21
- Routings..... 21
- Steps for Developing Workflow Applications..... 21
- Understanding Extended Workflow Capabilities..... 22
- Route Controls..... 22
- Workflow Triggers from External Applications..... 23
- EIPs..... 23
- Batch Workflow Processing..... 23
- Approval Processes..... 24
- Workflow Activity Guides..... 24
- Notification Features..... 24
- Worklist Feeds..... 25
- Chapter 3: Building Workflow Maps..... 27**
- Understanding Workflow Maps..... 27
- Workflow Maps..... 27
- PeopleSoft Navigator Maps..... 27
- Understanding Map Hierarchies..... 28
- Map Hierarchies..... 28
- Map Icons..... 29
- Business Processes..... 29

Activities.....	29
Defining Maps.....	30
Understanding Map Definition.....	30
Common Elements Used in This Section.....	31
Creating a New Map.....	31
Defining Business Process Properties.....	32
Defining Activity Properties.....	32
Adding Map Objects.....	33
Understanding Toolbar Buttons.....	33
Adding Icons to Maps.....	38
Connecting Icons Within a Map.....	38
Adding Images to Maps.....	39
Controlling Text.....	40
Adding Standalone Text to Maps.....	40
Formatting Standalone Text.....	40
Changing the Position of Icon Text.....	41
Adding Drawing Shapes to Maps.....	41
Adding Drawing Shapes to Maps.....	41
Changing the Appearance of the Drawing Line.....	41
Changing the Color and Pattern of a Drawing Shape.....	41
Using Other Map Display Features.....	42
Understanding Other Map Display Features.....	42
Controlling the Size of the Map Display.....	42
Viewing the Grid.....	42
Resizing the Grid.....	42
Activating the Snap-to Grid.....	43
Navigating Between a Business Process and Its Component Maps.....	43
Arranging Objects on Maps.....	43
Moving Objects on Maps.....	43
Deleting Objects from Maps.....	43
Changing the Display Bitmap of an Existing Icon.....	44
Aligning Multiple Objects Visually.....	44
Moving Objects in Front Of or Behind Each Other.....	44
Setting Icon Properties.....	44
Understanding Descriptive Icons.....	44
Setting Properties for Descriptive Icons.....	45
Setting Properties for Step Icons.....	45
Setting Attributes for Step Icons.....	46
Chapter 4: Defining Roles and Users.....	49
Understanding Roles and Users.....	49
User List Roles.....	49
Query Roles.....	49
Route Controls.....	50
Case Study: The Manager Query Role.....	50
Defining a Role Query.....	51
Maintaining Roles and Role Users.....	51
Understanding Roles and Role User Maintenance.....	52
Maintaining User Workflow Information.....	52
Chapter 5: Defining Worklist Records.....	53
Understanding Worklist Records.....	53
The Worklist.....	53

Worklist Records.....	53
Creating Worklist Record Definitions.....	55
Replicating Worklists.....	56
Understanding Worklist Replication.....	56
Setting Up Worklist Replication.....	57
Running the WL_REPLICATE Process.....	57
Checking the WORKLIST_MSG Status.....	58
Chapter 6: Adding Events and Routings.....	59
Understanding Events and Routings.....	59
Common Elements Used in Events and Routings.....	59
Events and Routings.....	59
Adding and Defining Events.....	59
Adding an Event.....	59
Defining the Event.....	60
Editing the Business Rules.....	60
Adding and Defining Worklist Routings.....	61
Prerequisites to Adding and Defining Worklist Routings.....	61
Creating Worklist Routings.....	61
Defining Worklist Attributes.....	62
Specifying Field Mappings.....	65
Adding and Defining Email Routings.....	68
Understanding Email Routings.....	68
Creating an Email Routing.....	68
Mapping Fields.....	69
Chapter 7: Defining Event Triggers.....	75
Understanding Event Triggers.....	75
Writing Workflow PeopleCode.....	75
Understanding Workflow PeopleCode.....	75
Using the TriggerBusinessEvent Function.....	75
Creating Workflow PeopleCode Programs.....	76
Cloning Business Processes and Activities.....	77
Writing PeopleCode for Approval Processes.....	77
Understanding Approval Processes.....	78
Using Virtual Approver.....	78
Using the GetApprovers Library Function.....	78
Using Additional PeopleCode Functions and Variables.....	78
Chapter 8: Using Additional Routing Options.....	81
Understanding Route Control Development.....	81
Route Control Development.....	81
Route Control Query Roles.....	81
Defining Route Controls.....	82
Understanding Route Control Definition.....	82
Adding Route Control Types.....	82
Building Route Control Profiles.....	83
Using Route Control Roles.....	83
Understanding Route Control Query Roles.....	84
Defining Routings in Application Designer.....	85
Reviewing Role Users.....	85
Understanding Role Users.....	85
Searching For and Reviewing Role Users.....	86
Chapter 9: Using Batch Workflow Processing.....	87

Understanding Workflow Batch Processes.....	87
Understanding Batch Workflow Applications.....	87
Workflow Batch Processing.....	87
Database Monitoring with PeopleSoft Application Engine.....	88
Events Triggered with Component Interfaces.....	88
Understanding Database Agents Conversion.....	88
Understanding the Notification Application Class.....	89
Creating Batch Workflow Applications.....	89
Understanding Batch Workflow Applications.....	89
Creating Batch Workflow Applications.....	89
Monitoring the Database with PeopleSoft Application Engine.....	91
Chapter 10: Defining Approval Processes.....	93
Understanding Approval Processes.....	93
Understanding Virtual Approver.....	94
Virtual Approver.....	95
Virtual Approver Templates.....	96
User List Roles for Organizational Levels.....	96
Understanding Approval Rule Sets.....	96
Creating Approval Rule Sets.....	97
Creating an Approval Rule Set.....	97
Specifying Approval Rule Properties.....	97
Specifying Additional Approval Rule Properties.....	99
Making an Effective-Dated Change to an Approval Rule Set.....	100
Defining Approval Steps.....	101
Understanding Approval Steps.....	101
Adding a Rule Step to a Rule Set.....	101
Defining a Rule Step.....	101
Specifying Rule Step Rules.....	105
Specifying Rule Step Events.....	106
Maintaining Approval Rules.....	108
Understanding Approval Rule Maintenance.....	108
Maintaining Approval Rule Steps.....	108
Triggering Virtual Approver Routings.....	110
Understanding Virtual Approver Routings.....	110
Adding Workflow Work Pages.....	110
Adding Virtual Approver PeopleCode.....	111
Reviewing Approval History.....	114
Reviewing Approval Instances.....	114
Using GetApprovers PeopleCode.....	115
GetApprovers.....	115
Chapter 11: Designing Workflow Activity Guides.....	117
Understanding Workflow Activity Guides.....	117
Understanding Workflow Activity Guide Creation.....	117
Creating and Defining Activities.....	117
Creating an Activity.....	117
Defining Step Attributes.....	118
Defining Workflow Activity Guide Options.....	120
Creating Workflow Activity Guide Pages.....	122
Understanding Workflow Activity Guide Pages.....	122
Creating Workflow Activity Guide Pages.....	122
Setting Up Access to Pages.....	123

- Understanding Workflow Activity Guide Page Access..... 123
- Understanding Workflow Activity Guide Mode..... 123
- Understanding Step Status..... 123
- Accessing Workflow Activity Guides Through Worklists..... 124
- Accessing Workflow Activity Guides Through Custom Links..... 124
- Chapter 12: Designing PeopleSoft Navigator Maps.....127**
- Understanding PeopleSoft Navigator..... 127
- Understanding Navigator Map Design..... 127
- Establishing Navigator Homepages..... 128
 - Understanding Navigator Homepages..... 128
 - Establishing a User's Homepage..... 128
 - Preparing a Business Process To Be a Navigator Homepage..... 128
 - Associating a Permission List with a Navigator Homepage..... 128
- Upgrading Maps to Work with PeopleSoft Navigator..... 129
- Chapter 13: Using Notification Templates..... 131**
- Understanding Notification Templates..... 131
- Defining Template Variables..... 132
 - Defining Template Variables..... 132
 - Defining Component Data Variables..... 133
 - Defining Component URL Variables..... 136
 - Defining External URL Variables..... 138
- Defining Additional Recipients..... 138
 - Understanding the Additional Recipients List..... 138
 - Defining the Additional Recipients List..... 138
- Defining Notification Templates..... 139
 - Defining Component Notification Templates..... 139
 - Defining BlackBerry Email Responses..... 141
- Calling Component Templates with PeopleCode..... 143
- Defining Generic Templates..... 143
 - Understanding Generic Templates..... 143
 - Defining Generic Templates..... 144
 - Using PeopleCode with Generic Templates..... 146
- Deleting Templates..... 147
- Accessing Notification Templates..... 147
- Sending Email Notifications in a User's Preferred Language..... 148
 - Understanding Sending Email Notifications in a User's Preferred Language..... 148
 - Sending Email Notifications using SetLanguage()..... 148
 - Storing Preconfigured Email Text in the Message Catalog..... 150
- Chapter 14: Designing BlackBerry Email Responses..... 151**
- Understanding RIM BlackBerry Email Responses..... 151
- Setting Properties for BlackBerry Email Responses..... 151
 - Understanding Application Server SMTP Settings for Sending Email Messages..... 151
 - Configuring the Email Channel..... 152
- Creating an Application Engine Program for Responses..... 153
 - Understanding Application Engine Programs for Responses..... 153
 - Activating the Send Notification Component..... 154
 - Running a BlackBerry Response Application Engine Process..... 155
- Chapter 15: Administering PeopleSoft Workflow.....157**
- Scheduling Workflow Processes..... 157
- Setting Workflow Defaults..... 157
 - Understanding Workflow Defaults..... 157

Setting Workflow System Defaults.....	158
Defining Worklist Messages.....	160
Understanding Worklist Messages.....	160
Defining a Default Message.....	160
Sending a Message.....	162
Receiving and Responding to Worklist Messages.....	163
Monitoring Worklist Volumes.....	163
Understanding Worklist Volume Monitoring.....	163
Configuring a Worklist Volume Monitor.....	163
Scheduling Worklist Volume Monitors to Run.....	165
Reviewing Notifications Sent by the Volume Monitor.....	166
Checking for Worklist Timeouts.....	167
Understanding Worklist Timeouts.....	167
Checking for Worklist Timeouts.....	167
Checking Timeout Worklist Data.....	167
Reviewing Work Items Online.....	168
Understanding Online Work Item Review.....	168
Searching for Work Items Based on Workflow Properties.....	168
Searching for Work Items Within a Worklist.....	170
Updating Work Items.....	171
Running Workflow Reports.....	172
Understanding Workflow Reports.....	172
Running Workflow Reports.....	173
Setting Notification Options.....	174
Enabling the Notify Toolbar Button.....	174
Setting Workflow Routing Options.....	174
Setting Delivery Options.....	175
Chapter 16: Configuring Worklist Search.....	179
Understanding Worklist Search.....	179
Creating New Worklist Search Definition.....	179
Generating the Query.....	180
Defining Search Definition.....	181
Defining Search Category.....	190
Deploying and Scheduling Worklist Search Index.....	193
Viewing Worklist Search Definition.....	199
Chapter 17: Migrating Workflow Data.....	201
Migrating Workflow Data.....	201
ADS Tables for Workflow Data Migration.....	201
Chapter 18: Understanding Worklist Entries Created by an External System.....	203
Understanding Worklist Entries from External Systems.....	203
Creating Worklist Entries by an External System.....	203
Understanding Routings and Security.....	216

Preface

Understanding the PeopleSoft Online Help and PeopleBooks

The PeopleSoft Online Help is a website that enables you to view all help content for PeopleSoft applications and PeopleTools. The help provides standard navigation and full-text searching, as well as context-sensitive online help for PeopleSoft users.

Hosted PeopleSoft Online Help

You can access the hosted PeopleSoft Online Help on the [Oracle Help Center](#). The hosted PeopleSoft Online Help is updated on a regular schedule, ensuring that you have access to the most current documentation. This reduces the need to view separate documentation posts for application maintenance on My Oracle Support. The hosted PeopleSoft Online Help is available in English only.

To configure the context-sensitive help for your PeopleSoft applications to use the Oracle Help Center, see [Configuring Context-Sensitive Help Using the Hosted Online Help Website](#).

Locally Installed PeopleSoft Online Help

If you're setting up an on-premises PeopleSoft environment, and your organization has firewall restrictions that prevent you from using the hosted PeopleSoft Online Help, you can install the online help locally. Installable PeopleSoft Online Help is made available with selected PeopleSoft Update Images and with PeopleTools releases for on-premises installations, through the [Oracle Software Delivery Cloud](#).

Your installation documentation includes a chapter with instructions for how to install the online help for your business environment, and the documentation zip file may contain a README.txt file with additional installation instructions. See *PeopleSoft 9.2 Application Installation* for your database platform, "Installing PeopleSoft Online Help."

To configure the context-sensitive help for your PeopleSoft applications to use a locally installed online help website, see [Configuring Context-Sensitive Help Using a Locally Installed Online Help Website](#).

Downloadable PeopleBook PDF Files

You can access downloadable PDF versions of the help content in the traditional PeopleBook format on the [Oracle Help Center](#). The content in the PeopleBook PDFs is the same as the content in the PeopleSoft Online Help, but it has a different structure and it does not include the interactive navigation features that are available in the online help.

Common Help Documentation

Common help documentation contains information that applies to multiple applications. The two main types of common help are:

- Application Fundamentals

- Using PeopleSoft Applications

Most product families provide a set of application fundamentals help topics that discuss essential information about the setup and design of your system. This information applies to many or all applications in the PeopleSoft product family. Whether you are implementing a single application, some combination of applications within the product family, or the entire product family, you should be familiar with the contents of the appropriate application fundamentals help. They provide the starting points for fundamental implementation tasks.

In addition, the *PeopleTools: Applications User's Guide* introduces you to the various elements of the PeopleSoft Pure Internet Architecture. It also explains how to use the navigational hierarchy, components, and pages to perform basic functions as you navigate through the system. While your application or implementation may differ, the topics in this user's guide provide general information about using PeopleSoft applications.

Field and Control Definitions

PeopleSoft documentation includes definitions for most fields and controls that appear on application pages. These definitions describe how to use a field or control, where populated values come from, the effects of selecting certain values, and so on. If a field or control is not defined, then it either requires no additional explanation or is documented in a common elements section earlier in the documentation. For example, the Date field rarely requires additional explanation and may not be defined in the documentation for some pages.

Typographical Conventions

The following table describes the typographical conventions that are used in the online help.

<i>Typographical Convention</i>	<i>Description</i>
Key+Key	Indicates a key combination action. For example, a plus sign (+) between keys means that you must hold down the first key while you press the second key. For Alt+W , hold down the Alt key while you press the W key.
... (ellipses)	Indicate that the preceding item or series can be repeated any number of times in PeopleCode syntax.
{ } (curly braces)	Indicate a choice between two options in PeopleCode syntax. Options are separated by a pipe ().
[] (square brackets)	Indicate optional items in PeopleCode syntax.
& (ampersand)	When placed before a parameter in PeopleCode syntax, an ampersand indicates that the parameter is an already instantiated object. Ampersands also precede all PeopleCode variables.

Typographical Convention	Description
⇒	This continuation character has been inserted at the end of a line of code that has been wrapped at the page margin. The code should be viewed or entered as a single, continuous line of code without the continuation character.

ISO Country and Currency Codes

PeopleSoft Online Help topics use International Organization for Standardization (ISO) country and currency codes to identify country-specific information and monetary amounts.

ISO country codes may appear as country identifiers, and ISO currency codes may appear as currency identifiers in your PeopleSoft documentation. Reference to an ISO country code in your documentation does not imply that your application includes every ISO country code. The following example is a country-specific heading: "(FRA) Hiring an Employee."

The PeopleSoft Currency Code table (CURRENCY_CD_TBL) contains sample currency code data. The Currency Code table is based on ISO Standard 4217, "Codes for the representation of currencies," and also relies on ISO country codes in the Country table (COUNTRY_TBL). The navigation to the pages where you maintain currency code and country information depends on which PeopleSoft applications you are using. To access the pages for maintaining the Currency Code and Country tables, consult the online help for your applications for more information.

Region and Industry Identifiers

Information that applies only to a specific region or industry is preceded by a standard identifier in parentheses. This identifier typically appears at the beginning of a section heading, but it may also appear at the beginning of a note or other text.

Example of a region-specific heading: "(Latin America) Setting Up Depreciation"

Region Identifiers

Regions are identified by the region name. The following region identifiers may appear in the PeopleSoft Online Help:

- Asia Pacific
- Europe
- Latin America
- North America

Industry Identifiers

Industries are identified by the industry name or by an abbreviation for that industry. The following industry identifiers may appear in the PeopleSoft Online Help:

- USF (U.S. Federal)

- E&G (Education and Government)

Translations and Embedded Help

PeopleSoft 9.2 software applications include translated embedded help. With the 9.2 release, PeopleSoft aligns with the other Oracle applications by focusing our translation efforts on embedded help. We are not planning to translate our traditional online help and PeopleBooks documentation. Instead we offer very direct translated help at crucial spots within our application through our embedded help widgets. Additionally, we have a one-to-one mapping of application and help translations, meaning that the software and embedded help translation footprint is identical—something we were never able to accomplish in the past.

Using and Managing the PeopleSoft Online Help

Select About This Help in the left navigation panel on any page in the PeopleSoft Online Help to see information on the following topics:

- Using the PeopleSoft Online Help.
- Managing hosted Online Help.
- Managing locally installed PeopleSoft Online Help.

PeopleTools Related Links

[PeopleTools 8.62 Home Page](#)

[PeopleSoft Search and Insights Home Page](#)

“PeopleTools Product/Feature PeopleBook Index” (Getting Started with PeopleTools)

[PeopleSoft Online Help](#)

[PeopleSoft Information Portal](#)

[PeopleSoft Spotlight Series](#)

[PeopleSoft Training and Certification | Oracle University](#)

[My Oracle Support](#)

[Oracle Help Center](#)

Contact Us

Send your suggestions to psoft-infodev_us@oracle.com.

Please include the applications update image or PeopleTools release that you’re using.

Follow Us

<i>Icon</i>	<i>Link</i>
	<u>Watch PeopleSoft on YouTube</u>
	<u>Follow @PeopleSoft_Info on X.</u>
	<u>Read PeopleSoft Blogs</u>
	<u>Connect with PeopleSoft on LinkedIn</u>

Getting Started with PeopleSoft Workflow Technology

PeopleSoft Workflow Technology Overview

Workflow capabilities enable you to efficiently automate the flow of information throughout your enterprise, crossing both application and functional boundaries. PeopleSoft Workflow Technology consists of a powerful set of tools that enables you to automate time-consuming business processes and deliver the right information to the right people at the right time. You can merge the activities of multiple users into flexible business processes to increase efficiency, cut costs, and keep up with rapidly changing customer and competitive challenges.

Many of the tasks that you perform throughout the day are part of larger tasks that involve several steps and several people. For example, when you order supplies, you are really initiating an approval process: someone else reviews the order and either approves or denies it. If the order is approved, a purchase order is sent to the vendor. If it is denied, notification is sent back to the person who submitted the original order. The term *workflow* refers to this larger process.

Using PeopleSoft Workflow Technology requires you to define, step by step, your business processes. The first step in implementing your workflow application is determining the business rules of your organization. This step involves taking fluid, subtle, and sometimes controversial practices and defining explicit rules of operation. Your business rules must be specific enough to give you a solid understanding of your project goals, but not so specific that they predefine a single solution—one that might be impossible to implement or will not provide adequate flexibility.

PeopleSoft Workflow Technology Implementation

This section discusses the steps required to build a workflow.

Step One: Design a Workflow Application

Complete these main steps when designing a workflow application:

1. Analyze and document your business requirements.
2. Diagram the process flow.
3. Document the workflow object attributes for business processes, activities, steps, events, and email and worklist routings.

In the planning phase of your implementation, take advantage of all PeopleSoft sources of information, including the installation guides, PeopleTools documentation, and the product documentation specific to your applications.

After clearly designing your workflow requirements, you can proceed to building the workflow.

Step Two: Build Supporting Definitions

If the applications required for your workflow do not already exist, build the definitions that you need for fields, records, pages, components, and menus.

See [Understanding Workflow Maps](#).

Step Three: Create Workflow Maps

Create the workflow maps comprising the steps, activities, and business processes required for your workflow, as determined in step one.

Use PeopleSoft Application Designer to create graphical maps that represent your business process. At this stage, you create maps only for the processes that are involved in the underlying application; you add PeopleSoft Workflow-specific elements to the maps when you define events and routings.

See [Understanding Workflow Maps](#) and [Understanding Navigator Map Design](#).

Step Four: Define Roles and Role Users

Define the roles and the role users, including any Query roles required for your workflow.

To ensure that work flows to the correct person, you must determine who that person is. You can find the right person using either Query roles or user list roles.

See [Understanding Roles and Users](#).

Step Five: Define Worklist Records

Create a record definition that will be used to store all of the application-specific information for the worklist.

The worklist record determines which fields of information the system stores for each work item, including the data needed to access the target page (the search keys for the page) and any additional information that you want to display in the worklist itself. Because different worklist entries can have different target pages and display data, you need separate worklist records for the different types of entries that will appear in the worklist.

See [Understanding Worklist Records](#).

Step Six: Define Workflow Objects

You define the workflow application in this step. You enter each of the objects into a business process definition in Application Designer, as determined in step one.

You will define the events and routings that make up workflow. Events and routings are both objects in the workflow maps. To define these workflow objects, you add the icons to the map, linked to the step representing the page where the triggering event occurs.

See [Understanding Events and Routings](#).

Step Seven: Define Event Triggers

Define the business rule in PeopleCode in the triggering application record definition. Workflow programs are defined in a record definition for one of the tables that the component accesses. They contain the business rules used to decide whether to trigger the business event. The PeopleCode detects when a business rule has been triggered and determines the appropriate action.

See [Understanding Event Triggers](#).

Step Eight: Test

Test your workflow, or use the workflow monitoring tools in Workflow Administrator to validate worklist routing results.

Chapter 2

Understanding PeopleSoft Workflow

Understanding PeopleSoft Workflow

Many of the daily tasks that you perform are part of larger tasks that involve several steps and several people working together. For example, when you enter an invoice, you are initiating an approval and payment process: someone else reviews and approves it, and a third person submits payment to the vendor. The term *workflow* refers to this larger process.

To a certain extent, all of the business processes that you define using PeopleSoft Application Designer involve workflow. However, we usually reserve the term to refer to processes that involve multiple users and the routing of data between the users.

This documentation describes the features of PeopleSoft Workflow Technology as they relate to business process design and workflow. These features include PeopleSoft Application Designer tools for designing workflow applications, adding workflow to your business processes, and tools for administering workflow within your organization. Other topics include notification features, Virtual Approver, and Research In Motion (RIM) BlackBerry handheld device response programs.

Understanding Workflow Tools

This section discusses the tools to create and use workflow applications:

Workflow Tools

You create and use workflow applications using several tools:

- Worklists are prioritized lists of the work items that a person (or group of people) has to do. A worklist is a standard PeopleTools grid; therefore, the user can use grid personalization features to order and sort columns. When work is routed to a PeopleSoft user, it is put in the user's worklist. To work on an item, the user selects it from the worklist and is presented with the appropriate page to begin work. Users accessing worklists through a browser see worklist entries prioritized in a predefined order (set on a properties page). For example, worklists for accounts receivable clerks can be sorted by days overdue, amount overdue, or credit class.

Note: The URL/ID field in the worklist grid is an HTML area which cannot be sorted and will not download into a Microsoft Excel spreadsheet.

- PeopleSoft Application Designer includes the tools that you use to design and build business processes, including the workflow rules and routings.
- PeopleCode functions detect when a business rule has been triggered as users enter data into a PeopleSoft application. These functions evaluate who should act on the new work instance (the role) and route it to the appropriate employee (the routing).

- PeopleSoft Workflow Administrator enables you to access, monitor, analyze, and control workflow in your organization.

Work Items

At the center of a workflow definition is a set of business events and the routings that are associated with those events. A business event is a condition that tells the system that an activity is complete. For example, a new record has been created, a record field has a particular value, or a due date has passed. A routing is an instruction that tells the system to forward information to the next step in the business process. It specifies what information to forward and where to forward it.

When a user saves a page, the system determines whether an event has occurred and triggers the associated routings. For example, suppose an employee enters a change of address from an online page. An agent determines that the database has been correctly updated and may then add an item to the benefits administrator's worklist to notify the insurance provider of the correct address.

In addition to adding work items to worklists, routings can send email messages.

Workflow Triggers

Workflow routings are initiated by Workflow PeopleCode. The PeopleCode is assigned to pages and, when you save a page, it triggers a business event and its related routings.

Any process that can trigger PeopleCode can trigger a workflow event, including:

- Users working in PeopleSoft pages.
- Third-party applications sending information to a PeopleSoft component through a component interface.
- Batch programs or queries sending information to a PeopleSoft component through a component interface. Batch workflow processing uses these tools in addition to the standard workflow tools:
 - Application Engine programs run queries behind the scenes and pass the results to a component interface.

You can use PeopleSoft Process Scheduler to run these programs on a regular schedule.

- A component interface accesses the component and its PeopleCode to trigger a business event, thus initiating a workflow.

Understanding Workflow Application Development

This section discusses how to develop workflow applications and the various factors involved.

Rules

Rules determine which activities are required to process your business data. For example, you might implement a rule that says department managers must approve all requests for external classes.

You implement rules through workflow events, such as PeopleCode that evaluates a condition and triggers a notification (a routing) when appropriate.

Roles

Roles describe how people fit into the workflow. A role is a class of users who perform the same type of work, such as clerks or managers. Your business rules typically specify which roles do which activities. For example, a rule can say that department managers (a role) must approve external course requests.

Roles direct the work to types of people rather than to individuals. Identifying roles instead of individual users makes a workflow more flexible and easier to maintain. Associating roles with users makes it easy to ensure workflow users the security access that they need to access the pages where they complete their work.

Roles remain stable, even as people change jobs. For example, if an employee in the Research and Development (R&D) department requests an external class, the system forwards the request to R&D Manager, not to Vic Rumpel, who is the current R&D manager. PeopleSoft application data serves as the basis for defining roles throughout your organization.

Routings

Routings specify where the information goes and what form it takes: email message or worklist entry. Routings make it possible to deploy applications throughout the enterprise. They work through the levels and departments of an enterprise to bring together all of the roles that are necessary to complete complex tasks.

Steps for Developing Workflow Applications

Workflow development progresses through eight steps:

1. Design the workflow application.

Before you start developing workflow applications, analyze the business processes that you want to automate. Identify the goal of each business process, what its component tasks are, and how the tasks should be divided into smaller activities and steps. Articulate the conditions that trigger a workflow event and what happens when those conditions occur. Understand who your workflow users are and how you'll determine who receives a work item.

As you design the workflow application, identify the workflow rules and how they relate to the data objects and transactions in the PeopleSoft system.

2. Build the underlying application.
3. Create workflow maps.

Use PeopleSoft Application Designer to create graphical maps that represent your business process. At this stage, you create maps only for the processes that are involved in the underlying application; you add PeopleSoft Workflow-specific elements to the maps when you define events and routings.

4. Define roles and users.

Define users' roles when you give them their user IDs. Roles are important in PeopleSoft Workflow. To ensure that work flows to the correct person, you must determine who that person is. You can find the right person using either query roles or user list roles.

5. Create a worklist record.

The worklist record determines which fields of information the system stores for each work item, including the data needed to access the target page (the search keys for the page) and any additional information that you want to display in the worklist itself. Because different worklist entries can have different target pages and display data, you need separate worklist records for the different types of entries that will appear in the worklist.

6. Define workflow objects.

Events and routings are both objects on the workflow maps. To define these workflow objects, add the icons to the map, linked to the step representing the page where the triggering event occurs.

7. Define event triggers.

After you create workflow processes, link them into the PeopleSoft applications by adding PeopleCode programs to the pages. The PeopleCode detects when a business rule has been triggered and determines the appropriate action.

8. Test.

No development is complete until the workflow is thoroughly tested. Be sure to test under a variety of conditions, both usual and unusual.

Understanding Extended Workflow Capabilities

In addition to basic workflow events and routings, PeopleSoft Workflow provides extended capabilities that add to the power of workflow applications. This section discusses these extended workflow capabilities.

Route Controls

Route controls identify the aspects of a situation on which you want to base routing decisions, and they enable you to associate values with role users. For example, suppose you want to route purchase requisitions to different buyers, depending on which vendor supplies the ordered items, which business unit is requesting the items, which department needs the items, or some combination of these factors.

Route controls simplify the creation of role queries by enabling you to associate application data with the role user definition. Instead of joining together a group of records, you can look at the role user table. Another advantage of route controls is that the factors controlling routing are stored in a database table instead of in query definitions or PeopleCode. To change the routing rules, you change users' route control profiles. You do not have to modify the business process, role queries, or PeopleCode.

Workflow Triggers from External Applications

A component interface enables third-party applications to enter data into PeopleSoft applications. It accepts data from a variety of sources, such as electronic forms software, interactive voice response (IVR) systems, or web applications, and from PeopleCode and Application Engine programs.

When a component interface sends data into the PeopleSoft system, the system performs the same edits and security checks as it always does, including running any PeopleCode that is associated with the page. Therefore, if the page has associated workflow PeopleCode, then a component interface can trigger a business event.

EIPs

The PeopleSoft application delivers a number of pre-configured EIPs to meet some of the common integration needs. These PeopleSoft Workflow-related EIPs may be particularly useful:

- The Worklist Entry EIP (component interface WORKLISTENTRY) enables third-party applications to access existing worklist entries, mark items as selected or worked, or reassign items to other users.
- The Worklist Synchronization EIP consolidates worklist data from multiple PeopleSoft databases using the application engine program WL_REPLICATE, which publishes worklist data using WORKLIST_MSG.

Users who would otherwise have to work from multiple worklists (for example, people who use PeopleSoft Workflow in both PeopleSoft HCM and PeopleSoft Financials) can use one worklist and still see all work items from both sources.

Third-party applications can also use this EIP to create new worklist entries, entries that can include a URL for the action that must be taken.

- The Worklist EIP (component interface WORKLIST) enables third-party applications to add new entries to PeopleSoft worklists.

This method is not the preferred way to add worklist entries. The preferred method is to use a component interface for a component that already calls TriggerBusinessEvent and to let TriggerBusinessEvent create the worklist entry. Another alternative is to use the Worklist Synchronization EIP.

- Third-party applications can use a web service request message to create worklist entries for a task that is external to a PeopleSoft application. The web service provides a reply message when the worklist item is marked complete.

Batch Workflow Processing

Sometimes, the event that triggers a workflow routing is actually a nonevent. That is, a situation exists but not because someone entered data into the system. The most common examples of this type of event are aging processes. For example, an invoice becomes overdue, an employee reaches his five-year anniversary, or a worklist entry remains unattended for more than a week.

PeopleSoft Application Engine enables you to monitor your database for this type of event. You can create an Application Engine program that runs a SQL query against the PeopleSoft database and passes the results to a component interface.

Using Application Engine programs in conjunction with PeopleSoft Process Scheduler, you can monitor the database tables for conditions that should trigger workflow events.

Approval Processes

Approval processes are a common form of business process, and you can define approval rules on an Approval Rule Set map. The approval steps that you place on this map represent the approval levels required for the activity in question.

Two tools can read and implement the approval rules from the map:

- Virtual Approver automatically tracks the approval process. As users complete transactions that require approvals, Virtual Approver determines the appropriate approver and sends a workflow routing. As each approver completes the approval, Virtual Approver determines whether additional approvals are needed and, if necessary, sends additional workflow routings.
- GetApprovers PeopleCode determines the entire list of required approvals at once, so that you can develop custom approval tracking applications.

Workflow Activity Guides

Workflow activity guides support a specific type of workflow: a single user's work across several pages. Because workflow activity guides are intended for a single user, they do not involve routings like those found in a regular workflow application. Rather, the workflow activity guide leads a user through a multistep task.

A workflow activity guide appears as a navigation bar across the top of a page. Within the bar, you can see each of the steps involved in the activity. Clicking a step takes you to the page where you can complete the step; the navigation bar remains visible as you move from page to page.

Workflow activity guides take a single map and integrate it into the pages that are used for the specific transaction. Although workflow activity guides can benefit all users, they are particularly appropriate for guiding untrained users through self-service transactions.

Of the two kinds of workflow maps (business processes and activities), only activities are used for workflow activity guides. The workflow activity guide maps are built with the same tools as all other maps.

Notification Features

Within an activity definition, an event can trigger a notification routing in email or a worklist. These features facilitate sending notifications in workflow:

- The Notify toolbar button can be added to any PeopleSoft component.

With the Notify toolbar button, the user can determine when an event has occurred that requires that someone be notified. The Notify toolbar button opens the Send Notification page, where the user can enter a personal message and send an email or worklist notification to users.

- Notification templates enable functional users to configure unique message text for each component.

The notification template can include values from the component page (for example, order number and customer name) so that even the predefined text in the notification can be specific to the data on the page. These values are called template variables.

- The BlackBerry Email Response notification setup and polling program enables companies to leverage the functionality of the Research in Motion (RIM) wireless handheld device to send and receive email.

The email response from the device can trigger business logic in the PeopleSoft system to update or complete a transaction.

- The combination of generic templates and PeopleCode application classes can be used by application developers to extend the delivered notification features for an application.

Worklist Feeds

Worklist feeds provide the ability to publish a user's worklist as a feed in real time. By using worklist feeds, the worklist items can be available from systems other than the system that originated the entries without copying the data. Worklist feeds use the Feed Publishing Framework for delivering feeds. PeopleTools delivers the WORKLIST feed data type used to publish worklist feeds.

Worklist feeds are real-time feeds. The feed is generated in the security context of the signed on user and reflects the user's current worklist items. It does not show worked or old items.

See [Understanding Worklist Entries from External Systems](#).

Chapter 3

Building Workflow Maps

Understanding Workflow Maps

This section discusses the workflow maps used in PeopleSoft.

Workflow Maps

Workflow maps, also known as PeopleSoft Navigator maps, are visual representations of your organization's business processes. Maps are necessary to all workflow processes, and they can also be used as navigational aids for users.

Workflow maps are of two types, each representing a different hierarchical level. The top-level map, known as a business process, represents broad areas of functionality. Business processes contain one or more activities, or subprocesses. Activities contain individual steps that represent the specific transactions that complete the activity.

When you create workflow maps, you first create basic maps (business processes and activities) as described in these topics. As you continue with subsequent steps, you add workflow-specific elements—events and routings—to the activities. You need events and routings only in activities that are used as workflow tools, not in those that are used as navigation tools.

PeopleSoft Navigator Maps

PeopleSoft Navigator is an alternative to the standard portal navigation. With PeopleSoft Navigator, users can see workflow maps and use them to access pages (but not external programs) that are represented within these maps.

PeopleSoft Navigator presents maps according to their hierarchical relationships. Users can browse the available maps and navigate to individual pages by clicking the step that represents the page. As users move from map to page and back to map, the Navigator tree remains visible on the left-hand side of the screen.

This example illustrates the fields and controls in PeopleSoft Navigator.

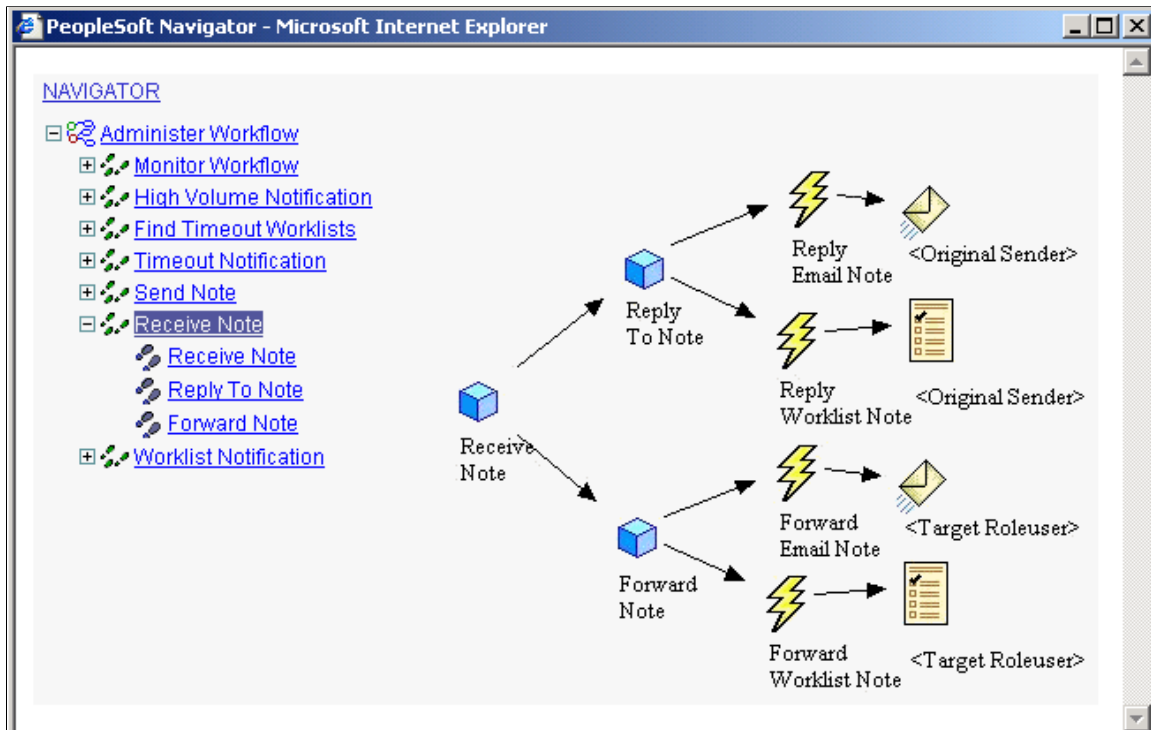

You control which maps are visible in PeopleSoft Navigator by defining a Navigator homepage: a top-level business process that greets the user when PeopleSoft Navigator is first accessed. Users can access only the maps that are hierarchically related to this homepage.

Understanding Map Hierarchies

This section discusses the map hierarchies in PeopleSoft.

Map Hierarchies

PeopleSoft Workflow uses three hierarchical levels. The first two levels, business processes and activities, are both maps: graphical representations of the relationships between the component objects (other maps or steps).

The third level, steps, are not maps. Steps are elements within activities. They represent the level at which the user interacts directly with application pages.



Business processes and activities are both freestanding definitions that you can open in PeopleSoft Application Designer and include in projects. Because business processes include icons for other maps (activities or other business processes), create these lower level maps before you add them to a business process. You can develop in a top-down approach by creating the lower level maps from the Business Process Designer directly.

Steps are not freestanding definitions in PeopleSoft Application Designer; they exist only within a particular activity. You create steps as you define an activity.

Note: PeopleSoft Workflow and PeopleSoft Navigator applications require all three levels: all activities must belong to business processes. Workflow activity guides, on the other hand, do not involve business processes. Workflow activity guides are built from standalone activities and their component steps. A setting in the Activity Properties dialog box identifies the activity as being used in a workflow activity guide.

Map Icons

The following table presents the basic map elements.

<i>Term</i>	<i>Definition</i>
	The Business Process icon represents a complete business task, consisting of one or more activities. Business processes can include other business processes. Normally, you use this functionality only when designing maps for use in PeopleSoft Navigator.
	The Activity icon represents a subprocess of the business task, consisting of one or more steps.
	The Step icon represents a discrete step in the business process, corresponding to a single transaction performed on an application page or through an external program.

Business Processes

A business process is a graphical representation of the relationships between related activities. Arrows show the relationships between the activities, indicating the proper chronological sequence.

Activities

Activities that are intended only for end users (in PeopleSoft Navigator or in workflow activity guides) typically include only steps that correspond either to application pages or to external programs.

When you incorporate workflow, activities also include events and routings. Events represent specific transactions that can occur in the page that is connected to the event. Routings represent notifications that are triggered by that event.

For example, several possible events appear on a page where managers approve orders. The manager can approve or deny the order, or send the order back to the employee for changes. Each event requires routings to inform the next person in the chain (a buyer, an additional approver, or the employee who submitted the original order) about what action must happen next.

This example illustrates an activity with workflow routings.

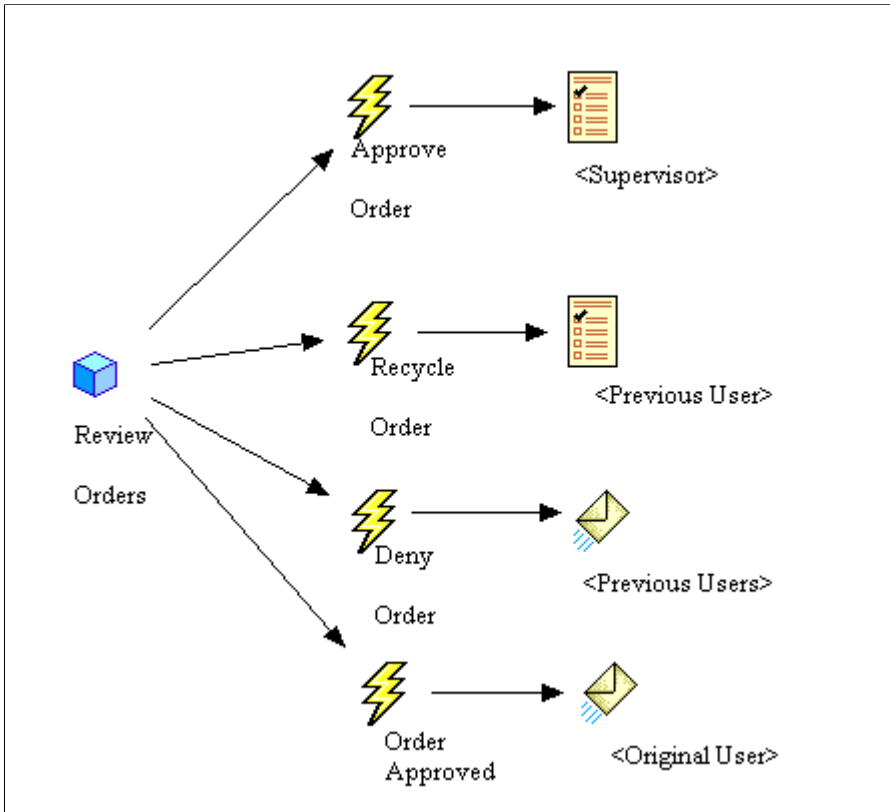

Defining Maps

This section provides an overview of map definition, lists common elements, and discusses how to create and define maps.

Understanding Map Definition

You create maps using PeopleSoft Application Designer. After creating the map, you can add items and establish the attributes of and relationships between the items.

Because maps are freestanding definitions in PeopleSoft Application Designer, use the standard techniques for opening, saving, deleting, renaming, adding to projects, printing, and so on.

Common Elements Used in This Section

<i>Field or Control</i>	<i>Description</i>
Icon Desc (icon description)	<p>Enter a description, which will appear in the dialog boxes that list this type of map. If you leave this field blank, the map name appears by default.</p> <p>This field is language-sensitive; the map name is not. If you intend to translate this object, supply a value for this field.</p>
Owner ID	To track definition owners, enter an appropriate value.

Creating a New Map

To create a new map:

1. In PeopleSoft Application Designer, select File, New.
2. In the New scrolling list, select the map type: Activity or Business Process.
3. Click OK.
4. Add the icons required to represent the activity or business process.

If you are creating a business process, the icons represent other maps, activities, and possibly other business processes. When you add these types of icons to the map, you can specify an existing activity or business process that the icon represents, or you are prompted to create a new one.

Even if you do not save the business process on which you are working, the new activities or business processes that you created are saved to the database. Arrange the icons in a logical and visually informative way.

If appropriate, add modeling symbols, drawings, arrows, text, or other graphic elements to the map. These elements are useful primarily in maps that are visible in PeopleSoft Navigator. They do not affect workflow processing, nor are they visible in workflow activity guides.

5. Connect the activities, decision points, and subprocesses in the appropriate order:
 - a. Click the **Link** button.
 - b. Click the two objects sequentially.

An arrow appears, pointing from the first object to the second.

The links between steps only clarify the flow of work. They do not directly determine the order of the steps, which you specify when you set the properties for individual icons in the maps. However, if you enabled automatic sequencing in the activity properties, then the default step order is based on the links.

6. Define the properties of the map.
7. Define the properties of the icons on the map.

8. Save the map.

Defining Business Process Properties

To define the properties of a business process:

1. Open the business process in PeopleSoft Application Designer.
2. Open the Business Process Properties dialog box and then:
 - a. Right-click in the map (but not on an item in the map).
 - b. Select Definition Properties.

The General tab in the Business Process Properties dialog box appears.

3. Set the properties on the General tab.
4. Set the properties on the Use tab.

A Navigator homepage is the high-level business process that a user sees immediately after accessing PeopleSoft Navigator. A user's homepage settings are established on the User Profile and Permission List pages. To make this business process available as a homepage, select the **Can be used as a Navigator home page** check box.

5. Click OK to accept the settings.
6. Save the business process.

Defining Activity Properties

To define the properties of an activity:

1. Open the activity in PeopleSoft Application Designer.
2. Open the Activity Properties dialog box and then:
 - a. Right-click in the map (but not on an item in the map).
 - b. Select Definition Properties.

The General tab in the Activity Properties dialog box appears.

3. Set the properties on the General tab.
4. Set the properties on the Use tab.

The Use tab includes options for automatically sequencing steps and for enabling end-user-facing workflow activity guides.

After you add steps to an activity, arrange them into a logical sequence using connecting arrows, and assign each step a number. If you select **Automatically sequence steps**, the step numbers are automatically assigned when you save the activity. The step numbers are based on the order in which you connect the arrows. This is an efficient way to order the steps.

Select **Activity Guide** if you are creating a map to use as the basis for an end-user-facing workflow activity guide.

Note: Normally, an activity that you use in a workflow application isn't reused as a workflow activity guide. Instead, you create activities specifically for workflow activity guides.

5. Click OK to accept the settings.

Adding Map Objects





This section provides an overview of toolbar buttons and discusses how to use icons in maps.

Understanding Toolbar Buttons

Use toolbar buttons to add icons and connecting lines to maps. Different toolbars (and, therefore, different map objects) are available for business processes and activities.











Business Process Toolbar

This toolbar provides the basic components of a business process, including activities and the lines that link them. This toolbar is visible only when a business process is the active window.

<i>Term</i>	<i>Definition</i>
	Click the Link button to connect related activities or steps. This button also appears in the Activity toolbar. You must use the link tool to connect objects on the map; do not use arrows or other drawn shapes.
	Click the Business Process button to add another business process.
	Click the Activity button to add an activity.
	Click the Decision button to add a decision point in a process. A Decision icon in a map is descriptive only; it has no workflow functionality. This button also appears in the Activity toolbar.







Activity Toolbar

This toolbar provides the basic components of an activity, including steps, workflow events, and workflow routings. This toolbar is visible only when the active window displays an activity.

Term	Definition
	Click the Link button to connect related activities or steps. This button also appears in the Business Process toolbar.
	Click the Step button to add a page.
	Click the Event button to add a business event.
	Click the Worklist button to add a worklist.
	Click the Email button to add email for workflow routing.
	Click the Batch button to create a descriptive icon for a background process.
	Click the Manual Process button to create a descriptive icon for a manual process.
	Click the Decision button to create a descriptive icon for a decision point in a process. This button also appears in the Business Process toolbar.
	Click the Local Transaction button to create a descriptive icon representing a service operation definition for a transaction that occurs in one database.
	Click the Transaction other DB (transaction other database) button to create a descriptive icon representing a service operation definition for a transaction that sends a message to another database in the same enterprise.
	Click the Remote Transaction button to create a descriptive icon representing a service operation definition for a transaction that sends a message to another database in another enterprise by crossing the firewall. Service operation definitions are used in PeopleSoft Integration Broker.

Modeling Toolbar









This toolbar provides additional buttons for creating icons to graphically enhance maps. Some of the icons are informational only; those that are functional have exact equivalents in either the Business Process or the Activity toolbar. This toolbar is visible when either a business process or an activity is the active window in the workspace.

<i>Term</i>	<i>Definition</i>
	Click the Document button to create a descriptive icon for a document. (Informational only.)
	Click the End Process button to create a descriptive icon for the end of process. (Informational only.)
	Click the Business Process button to add an icon for a business process. This is the same function as the Business Process button on the Business Process toolbar. When you add this icon to a map, you are prompted to identify an existing business process that the icon represents. This functionality is available only when a business process is the active window in the workspace.
	Click the Activity button to add an icon for an activity. This is the same function as the Activity button in the Business Process toolbar. When you add this icon to a map, you are prompted to identify an existing activity that the icon represents. This functionality is available only when a business process is the active window in the workspace.
	Click the Event button to add an icon for an event. This is the same function as the Event button in the Activity toolbar. This functionality is available only when an activity is the active window in the workspace.
	Click the Page button to add an icon for a page. This is the same function as Step button in the Activity toolbar. This functionality is available only when an activity is the active window in the workspace.

Drawing Toolbar



This toolbar is visible when either a business process or an activity is the active window in the workspace.





Normally, you add an object to a map by clicking the object in the toolbar and clicking the location on the map. Some of the drawing tools, however, involve extra clicks on the map. For example, to draw a line, first click the **Line** button as you click any other button. To draw the line on the map, click once at the beginning of the line and again at the end of the line.

<i>Term</i>	<i>Definition</i>
	Click the Line button to draw a static line. Drag the cursor from one end of the line to the other. You can move the endpoints later.
	Click the Arrow Line button to draw a line that terminates with an arrow.
	Click the Rectangle button to draw a rectangle. Drag the cursor from one corner of the rectangle to the opposite corner. You can move the corners later.
	Click the Polycurve button to draw a curve. Drag from anchor point to anchor point, and double-click at the end of the curve. You can move the anchor points later.
	Click the Ellipse button to draw an ellipse. Drag from one corner of the surrounding rectangle to the opposite corner. You can move the corners later.
	Click the Text button to draw a static text field. Place text by clicking at the appropriate location. You can move or resize the text box later.
	Click the Image button to add a bitmap. Place the bitmap by clicking at the appropriate location.
	Click the Toggle Grid button to display or hide an optional grid to help you place map objects.

Alignment Toolbar





This toolbar contains options for aligning objects on several different axes.

<i>Term</i>	<i>Definition</i>
	Click the Align Top button to arrange all selected objects so that they are aligned at the top of the base position object.
	Click the Align Middle button to arrange all selected objects so that they are aligned at the middle of the base position object.

<i>Term</i>	<i>Definition</i>
	Click the Align Bottom button to arrange all selected objects so that they are aligned at the bottom of the base position object.
	Click the Align Left button to arrange all selected objects so that they are aligned at the left-hand side of the base position object.
	Click the Align Center button to arrange all selected objects so that they are aligned at the center of the base position object.
	Click the Align Right button to arrange all selected objects so that they are aligned at the right-hand side of the base position object.

Layering Toolbar

This toolbar contains options to move objects in front of or behind each other.

<i>Term</i>	<i>Definition</i>
	Click the Front button to move the selected object in front of any overlapping objects.
	Click the Back button to move the selected object behind any overlapping objects.
	Click the Forward button to move the selected object in front of the overlapping objects that are immediately in front of it.
	Click the Backward button to move the selected object behind any overlapping objects that are immediately in front of it.

Events and Routings Icons

These icons are actual workflow objects, representing transactions that trigger workflow (events) and the medium through which the trigger sends work to the recipient (routings). You normally add these objects to activities after completing the basic maps.

This example illustrates the events and routings icons.

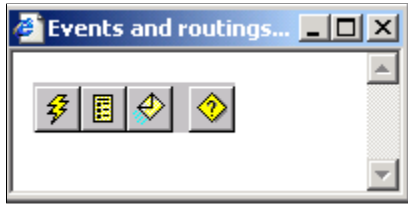

Adding Icons to Maps

To add an icon to a map:

1. Click the toolbar button representing the icon that you want to add.
2. Click the map where you want to place the icon.

In most cases, the icon is added to the map when you click. If you are adding an icon for an activity, business process, or transaction, however, the Select Definition dialog box appears.

3. In the Select Definition dialog box, select the specific activity, business process, or service operation definition that the icon represents.
4. Click the **Select** button to finish placing the icon on the map.

Connecting Icons Within a Map

To connect icons within a map:

1. Click the **Link** button on the toolbar.

You must use the link tool to connect icons; do not use arrows or other drawing objects.

2. Click the icon where the link starts.

The icon must be a linkable definition. As you pass the cursor over different parts of the map, its appearance changes to indicate whether you are over a linkable definition:

- A plus sign indicates that you are not over a linkable definition.
- A plus sign within a circle indicates that you are over a linkable definition.

3. Click the icon where the link ends.

This click completes the link, and an arrow from one object to the other appears. Even if you relocate objects on the map, the link stays connected to both objects.

To cancel without completing the link, right-click.

4. (Optional) Modify the shape of the link.

To create angles at the same time that you create the link, make one or more intermediate clicks where you want the line to bend. You can add multiple angles. However, you must always end the line with a linkable definition.

Change the angle by clicking the connector line, selecting the angle anchor, and moving it.

To create an angle in an existing link, select the link, press and hold the **Ctrl** key, and click where you want to create an angle anchor. You can then move the anchor as described previously.

Adding Images to Maps

To add an image to a map:

1. Click the **Image** button in the toolbar.
2. Click on the map where you want to place the image.
3. Right-click the bitmap and select Change Bitmap.

The Select Image dialog box appears.

4. Select the image file.
5. Click OK.

The selected image replaces the default bitmap.

Note: The Select Image dialog box lists all of the images that are stored in the PeopleSoft database. If the **Show Only Workflow Images** check box is selected, the list includes only images that have the Used in Workflow property set in the image definition properties. If the **Show Only Workflow Images** check box is cleared, the list includes all images that can be rendered in the Microsoft Windows environment. Because Graphics Interchange Format (GIF) files cannot be rendered in Windows, they do not appear.

Table of Default Workflow Images

To replace the PeopleSoft default images for new or existing maps, you can add new images to the Image Catalog using the same names, as shown in this table:

<i>Type</i>	<i>Image Name</i>	<i>Toolbar Name</i>
Activity	PT_WFD_ACTIVITY	PT_WFD_TBACTIVITY
Business Process	PT_WFD_BUSPROC	PT_WFD_TBBUSPROC
Step	PT_WFD_STEP	PT_WFD_TBSTEP
Batch	PT_WFD_BATCH	PT_WFD_TBBATCH
Manual Process	PT_WFD_MANUALPROC	PT_WFD_TBMANUALPROC
Transaction Same DB	PT_WFD_SAMEDB	PT_WFD_TBSAMEDB

Type	Image Name	Toolbar Name
Transaction Other DB	PT_WFD_OTHERDB	PT_WFD_TBOTHERDB
Transaction Outside Firewall	PT_WFD_OUTSIDEFW	PT_WFD_TBOUTSIDEFW
Event	PT_WFD_EVENT	PT_WFD_TBEVENT
Worklist	PT_WFD_WORKLIST	PT_WFD_TBWORKLIST
Email	PT_WFD_EMAIL	PT_WFD_TBEMAIL
Decision	PT_WFD_DECISION	PT_WFD_TBDECISION
Bitmap	PT_WFD_BITMAP	PT_WFD_TBBITMAP

Controlling Text

This section discusses how to control text in maps.

Adding Standalone Text to Maps

To add standalone text to maps:

1. Click the **Text** button in the Drawing toolbar.
2. Click the map in the location where you want to place the text.

A text box with the word *text* appears on the map.

3. Double-click the default text to select it.
4. Enter your own text.

Formatting Standalone Text

To format standalone text:

1. Right-click the text and select Item Properties.

The Text Properties dialog box appears.

2. Set the text properties.
3. Click OK.

Changing the Position of Icon Text

To change the position of icon text:

1. Click the text to select it.
2. Drag the text to its new position.

You might want to center caption text under the object that it describes.

Adding Drawing Shapes to Maps

This section discusses how to include drawing shapes in maps.

Adding Drawing Shapes to Maps

To add drawing shapes to maps:

1. Click a drawing shape button.
2. Draw the shape on the map.

The drawing method depends on which shape you are drawing.

3. Modify the shape by dragging the handles to a new location.

Changing the Appearance of the Drawing Line

To change the appearance of the drawing line:

1. Double-click the shape to open the Properties dialog box.
2. Set the properties on the Line tab.

Click Transparent to make the line disappear. When you select this option for a line, only the arrowhead on the line remains visible.

3. Click OK to close the dialog box.

Changing the Color and Pattern of a Drawing Shape

Because lines and curves do not enclose a drawing area, this procedure applies only to rectangles and ellipses.

To change the color and pattern of a drawing shape:

1. Double-click the shape to open the properties dialog box.
2. Set the properties on the Fill tab.
 - For a solid fill (no hatching), select a foreground color to fill the shape.

- To prevent the drawing from covering other shapes behind it, select Transparent Fill.
- For a patterned fill, select both a foreground and background color, and select a hatch pattern.

Select Transparent Background to apply hatches while leaving the fill transparent. The pictures of the hatching options show the color scheme that you selected.

3. Click OK to close the dialog box.

Using Other Map Display Features

This section provides an overview of other map display features and discusses the corresponding options available in these features.

Understanding Other Map Display Features

When you create a map, additional display options help you control the design environment. For example, maps have an optional grid to help you align objects precisely on the map. You can view or hide the grid, define its size, and specify whether objects snap to the grid intersections when you place or move them.

Controlling the Size of the Map Display

To change the display (zoom) size of the map:

1. Select View, Zoom.
2. Select the level of magnification.
3. Click OK.

Viewing the Grid

To view or hide the grid, select View, Grid Visible. This menu item is a toggle command. When the grid is visible, a check mark appears next to the menu item. By default, the grid is visible.

Resizing the Grid

To resize the grid:

1. Select Edit, Grid.

The Window Grid dialog box appears.

2. Select how much space (in pixels) should appear between the lines of the grid. Select the width (the number of pixels between the vertical lines) and the height (the number of pixels between the horizontal lines).
3. Click OK to close the dialog box.

If the grid is visible, it displays the new grid line settings. If the grid is not visible, the new settings take effect, although you cannot see them.

Activating the Snap-to Grid

When the Snap to Grid feature is active, PeopleSoft Application Designer positions all objects so that each has a corner at an intersection of the grid. The grid does not have to be displayed for this option to work. This menu item is a toggle command. When the option is selected, a check mark appears next to the menu item. By default, this option is not selected.

Navigating Between a Business Process and Its Component Maps

A business process comprises lower-level maps. These lower-level maps, whether activities or other business processes, are freestanding objects in PeopleSoft Application Designer. For convenience, open the lower-level maps directly from the business process map, rather than using the standard File, Open command.

To access a map that is part of a business process, double-click the icon for the lower-level map within the business process, or right-click the icon and select View Definition.

Arranging Objects on Maps

This section discusses how to arrange objects on maps.

Moving Objects on Maps

To move objects on maps:

1. Select the object.

Handles appear around the object.

2. Drag the object to a new position.

When you drag an object, caption text moves with it. You can, however, select or move just the text to reposition it relative to its object.

If an object is linked to other objects, the lines representing links move with the object.

Use the Snap to Grid feature to align the object to the grid or deactivate the Snap to Grid feature for free-form placement.

Deleting Objects from Maps

To delete objects from maps:

1. Select the object to delete.
2. Press **Delete**.

Changing the Display Bitmap of an Existing Icon

To change the display bitmap of an existing icon:

1. Right-click the icon and select Change Bitmap.

The Open dialog box appears.

2. Select the image file.
3. Click **OK**.

The selected image replaces the default bitmap.

Note: The Open dialog box for Change Bitmap lists only images that are Microsoft Windows-compatible. Also, when the system saves the activity or business process definition, it automatically generates a JPEG file of it so that it can be viewed in PeopleSoft Navigator (in the browser).

Aligning Multiple Objects Visually

To align multiple objects visually:

1. Decide on a base position object; you'll move other objects in line with this base position object.
2. Press **Shift** while selecting the objects that you want to move.

Select the base position object last. To deselect an object, continue to press **Shift** and select the object again.

3. Click the appropriate button in the Alignment toolbar.

Moving Objects in Front Of or Behind Each Other

To move objects in front of or behind each other:

1. Select the objects that you want to move in front of or behind another overlapping object.
2. Click the appropriate button on the Layering toolbar.

Setting Icon Properties

This section provides an overview of descriptive icons and discusses how to set icon properties.

Understanding Descriptive Icons

Both business processes and activities can include descriptive icons. These icons typically do not have associated workflow processing; they are useful primarily if the map will be visible through PeopleSoft Navigator.

Note: Even though the Activity icon does not have any associated processing, it must be included in the business process to establish the relationship between the activity and the business process. That relationship is necessary for proper workflow processing.

Setting Properties for Descriptive Icons

To set properties for descriptive icons:

1. Right-click the descriptive icon and select Item Properties.

The Properties dialog box appears. Depending on the type of icon, the title bar reads Business Processes Definition, Activity Definition, or Description Symbol Definition.

2. Enter information in the dialog box.

The text that you enter in the **Name** field identifies the icon and, by default, appears as the display text under that icon. To display different text under the icon, enter it in the **Icon Descr** text box. Include line breaks in the text by pressing the **Enter** key.

3. Click OK to close the dialog box.

Setting Properties for Step Icons

Set properties for the steps in an activity to associate the step with the proper page or external program and to establish the correct sequence of steps within the activity.

To set properties for step icons:

1. Right-click the step icon and select Item Properties.

The Step Definition dialog box appears.

2. Enter descriptive information about the step.
3. Enter the step and path numbers to place this step into the activity flow.

The **Step Number** and **Path Number** boxes order the steps in this activity. When the user always completes the same steps in the same order, specify the order of the step in the **Step Number** box and leave the number *1* in the **Path Number** box. The first step is Step 1; the second is Step 2.

When the user performs different tasks along the way, define multiple step paths. Start numbering the steps from Step 1, staying on Path 1 until you reach the first point at which a user has options. For each step that might come next, use the next consecutive step number, but a different path number, for each one. All of the steps should have the same step number sequence, but a different path number value.

If a user-facing workflow activity guide based on this map is available, you might want to make the more common path the default path. Select **Default Step** for the step that you want the workflow activity guide to take when a user progresses through the activity.

You can avoid the manual sequencing of steps if you use the automatic step sequencing options that are available in the property sheet for the activity. However, always review the sequence created by automatic numbering to verify that the sequence is correct.

4. (Optional) Click the **Activity Guide** button.

This button is available only if you have marked this as an activity guide in the activity properties. The Step Internet Client Attributes dialog box appears. If this map is an activity that will be used in a workflow activity guide, enter the necessary information in this dialog box.

Setting Attributes for Step Icons

This section discusses how to set step attributes.

This example illustrates the fields and controls on the Step Attributes dialog box.

Use the Step Attributes dialog box to select the page or program that the system starts when a user selects this step and the action mode that is used to open the page.

To set step attributes:

1. On the Step Definition dialog box, click the **Attributes** button.
2. Specify whether the user completes this step on a PeopleSoft page or from an external program.

When you select **Page** or **External Program**, the appropriate section of the dialog box becomes available. If this is a workflow activity guide and you marked the activity guide option in the activity properties, then you must select **Page**.

3. Provide directions for starting the page or external program.

If a user performs the step by completing a PeopleSoft page, select the page from the list boxes in the **Processing Page** group box.

In the **Action** drop-down list box, select the type of activity that the user must perform on the database: *Add*, *Update/Display*, *Update Display/All*, or *Correction*. When a user selects this step, the system displays the specified page in the specified action mode.

Note: You must assign a page to a menu before you create a step that navigates to it.

If users perform the step using an external program, select the program name and its working directory from the **External Program** group box. The program name must be the name of the executable file, followed by command line parameters, if appropriate. When a user selects this step, the system starts the specified program.

Note: If this step is the first step in its activity (Step 1 Path 1) and the activity has an associated worklist, the system can pass additional parameters to the external program from the worklist record.

4. Click OK in the Step Attributes dialog box.
5. Click OK to close the Step Definition dialog box.

Chapter 4

Defining Roles and Users

Understanding Roles and Users

You can define a role as a fixed list of individual role users or as a query that selects one or more role users at runtime.

This section discusses different roles and users available in PeopleSoft application.

User List Roles

This PeopleSoft application delivers a set of default user-list roles corresponding to the levels within an organization, such as EMPLOYEE, MANAGER, and VICE PRESIDENT. These roles are intended primarily for use with route controls.

Use the following criteria to determine how to define a role:

- The role, rather than the specific person, assigned to the task is important. For example, if a training clerk enrolls employees in classes, the TRAINING CLERK role can be defined as a list of users, because *any* clerk can enroll an employee in a class. The system forwards enrollment requests to the worklist for training clerks, and the first clerk who selects the request handles it. (In PeopleSoft Workflow terminology, the users are working from a pooled worklist.)
- You want everyone who fills the role to receive the same set of work items. For example, if you want the automated Worklist Monitor to send email messages to several people when worklist volumes become too high, you can route messages to a role called SYSTEM ADMINISTRATOR. Every administrator receives the messages.
- Only one person fills the role.

For example, the CHIEF FINANCIAL OFFICER role can be a user list, even though the list is very short.

Related Links

[“Understanding Roles” \(Security Administration\)](#)

Query Roles

Define a role as a query if you want to send work items to different people at different times. When an employee’s manager must approve a training request, the manager role is a query, because you want to send enrollment requests to different managers, depending on who makes the request.

When a role is defined as a query, the system determines who should receive a work item based on the values of fields on the page that triggers the routing. It uses context information from the current record

to determine who needs to complete the work. For example, the manager role query uses the value of the Employee ID field from the course request to look up the name of the employee's manager.

Because of the flexibility they bring to business processes, query roles are more common than user list roles.

When you create a query role, you tell the system how to determine who fills the role at runtime. You do not need to assign role users to the role, as you do with user list roles. However, you must set up the query by:

1. Writing a query in PeopleSoft Query. The query identifies the users to whom the work item is routed. The query must take a value from the page that triggers the event, such as the user ID or employee ID, and return a list of role users.
2. Defining the role through PeopleSoft Security Administration. For query roles, you pick the query that you want to run.
3. Assigning the role to the appropriate workflow routings. Because the query has runtime bind variables, you must also specify which page field values to copy into the query.

Route Controls

The PeopleSoft Workflow Administrator enables you to define route controls. For example, suppose that you want to route purchase requisitions to different buyers, depending on which vendor supplies the ordered items, which business unit is requesting the items, and which department needs the items. You can define a route control for each factor—vendor ID, business unit, and department—and specify a range of values for each buyer.

Case Study: The Manager Query Role

When an employee requests an external course, we route the request to the employee's manager. Because we route requests to different people, depending on who submits the request, we must define the manager role as a query.

A role query returns one or more role-user IDs based on the data that is saved on the page triggering the routing. In our case, we need a query that takes an employee's EMPLID (which is available on the course request form) and returns the role user ID of the employee's manager.

This is the SQL statement for the [ROLE] Manager query (with the effective date logic removed for simplicity):

```
SELECT C.ROLEUSER
FROM PS_JOB A, PS_DEPT_TBL B, PS_ROLEXLATOPR C
WHERE B.DEPTID = A.DEPTID
AND A.EMPLID = :1
AND C.EMPLID = B.MANAGER_ID
```

The Query Selects Role User IDs

The system uses role queries to determine which role users receive the work items. Therefore, the role query should select only ROLEUSER, from either the ROLEXLATOPR or ROLEUSER record

definition. No matter how complex the query is—how many joins or selection criteria it has—it must return ROLEUSER only.

Bind Variables Correspond to the Contextual Factors

You define a role as a query because you want to route items differently based on the context of the transaction that the user is performing. So every role query contains at least one bind variable with a value that is set at runtime. The bind variables correspond to the data on which you want to base the routing decision. In our example query, we want to route requests differently based on the EMPLID of the requester, so we should include a bind variable to set the EMPLID.

Note: At runtime, the system sets the values of the bind variables based on data from the page that triggers the routing. When you create the query, make sure that each bind variable matches a field from the page.

Defining a Role Query

To define a role query:

1. Select Reporting Tools, Query, Query Manager, Create New Query.
2. Select the Workflow record definition that you want to query.

A role query returns a set of role users, so the record definition that you want is either ROLEUSER (which lists role users and the role to which they are assigned) or ROLEXLATOPR (which lists role users and their IDs).

3. Select ROLEUSER as the only SELECT field.
4. Specify the criteria for finding role users.

For example, to define the manager role, join the ROLEXLATOPR record definition with a record definition that identifies each user's manager.

Because you create query roles to route items differently based on the context (for example, which employee created the item) the query usually includes at least one runtime prompt. The runtime prompts (or bind variables) correspond to the data on which you want to base the routing decision. At runtime, the system sets the values of the variables based on data from the page that triggers the event.

5. Select Properties.
6. Select Role as the query type.
7. Save the role query using a name that begins with [ROLE] so that you can identify it as a role query.

Maintaining Roles and Role Users

This section provides an overview of roles and role user maintenance and discusses how to maintain user workflow information.

Understanding Roles and Role User Maintenance

Role users are the people who participate in automated business processes. Because role users must all have PeopleSoft user IDs, maintaining role users is typically a security administrator's task.

Note: Workflow applications might involve role users who do not have access to the PeopleSoft system. For example, if the order processing workflow delivers electronic order forms to vendors, the vendors are role users. Those users still need PeopleSoft user IDs with information such as email address. Be sure that the security profile that is associated with the user ID doesn't allow access to the PeopleSoft system by leaving the password field blank in the user profile.

Maintaining User Workflow Information

The component used to maintain user IDs includes a page specifically for workflow information.

To maintain user workflow information:

1. Select Security, Permissions and Roles, Roles, Workflow to access the User Profiles - Workflow page.
2. Select the following options as needed.

Field or Control	Description
Allow notification	Select to cause the Notify button to appear on all components that have a Notify button defined.
Allow Recipient Lookup	Select to make available the Recipient Lookup link on the Send Notification page. This link enables the user to select a recipient name listed in the user profile (or LDAP server).
Use Query to Route Workflow	Select to use a query to route workflow.

Related Links

“Specifying Workflow Settings” (Security Administration)

Chapter 5

Defining Worklist Records

Understanding Worklist Records

This section provides overviews of the worklist and worklist records.

The Worklist

The worklist can include several different types of items at once. For example, a manager might have entries related to approving both employee course enrollments and orders for supplies.

Although both types of entries appear in the manager's worklist, the underlying data is different. The course enrollment entries might display information about the course name and start date, while the orders might have information about the descriptions and prices of ordered items.

Worklist Records

Entries in worklists are stored in database tables. You define the structure content of these tables by creating worklist records. The worklist record determines which fields of information the system stores for each work item and in what order the work items appear.

When a business event routes a work item to a worklist, it adds a row to the table. When a user finishes with a work item, the system marks the row as worked.

The basic procedure for creating a worklist record definition is the same as for any record definition, but worklist record definitions have some special requirements.

Worklist Record Definitions

When you create a worklist record definition, you define what a work item in a worklist looks like. The system uses the worklist record definition to:

- Link each work item with the underlying workflow tracking information, which is stored in a workflow system record (PSWORKLIST).
- Display relevant information about each work item on the Worklist page so that users can select the item on which they want to work.
- Retrieve the record that is associated with the work item so that the user can work on it.

System Fields

The first fields in a worklist record definition must always be the following system fields:

System Field	Description
BUSPROCNAME	The business process that includes the work item.
ACTIVITYNAME	The activity that triggers the worklist routing.
EVENTNAME	The business event that triggers the worklist routing.
WORKLISTNAME	The worklist in which the work item is waiting.
INSTANCEID	The system-assigned ID for the work item.
TRANSACTIONID	The system-assigned transaction ID for the work item. When an event triggers multiple routings, each work item has the same transaction ID, but a different instance ID.

The system uses these fields to link the items in the worklist with their tracking information, which is stored in the PeopleSoft-defined table PSWORKLIST. They must be defined as ascending key fields in the worklist record definition.

Virtual Approver, a specialized type of workflow used for approval processes, requires one additional system field. If you are using Virtual Approver, you must also add the APPR_INSTANCE field as a non-key field in the worklist record definition. This field stores the ID assigned to the work item for Virtual Approver processing.

Application Fields

The next set of fields in a worklist record definition are those specific to the application that creates the worklist. The system uses these fields to retrieve the associated record from the database when the user selects a worklist entry and moves to the page where the work is done. Note that:

- Because the system uses the values from these fields to search for the associated database record, you must include all of the key fields for the search record.
- Application field names cannot be the same as key words used in field mapping.
- All of the application fields appear in the user's worklist, unless you suppress them by including the special field WORKLIST_DESCR.

Worklist Display Fields

The last two fields in a worklist record definition are for descriptive information that appears in the worklist. These fields are optional.

Worklist Display Field	Description
WORKLIST_URL	The text that links to the page where the user can work on the item. Appropriate values might include the key data for the record in which the item will be worked. For example, for a work item directing a manager to approve an expense report, the text might be the name of the employee who submitted the report.
WORKLIST_DESCR	A text comment that appears in the user's worklist. The presence of this field automatically suppresses the display of any application fields, although the key fields are still used to bypass the search page of the target page.

On the Worklist Details page, these values appear as the **Link** and **Comment** fields. The link also appears on the main Worklist page.

Creating Worklist Record Definitions

To create a worklist record definition:

1. In PeopleSoft Application Designer, add the required system fields to the record definition.

Identify the required system fields as key fields with ascending sort order.

2. Add the key fields from the search record for the page that group users use to process the worklist entries.

The worklist record must include the search record key fields so that the system can locate the record on which the user must work.

3. (Optional) If users work on work items using an external program, rather than a PeopleSoft page, add a character field named `COMMAND_PARM`.

When you define a step in an activity, you can specify that an external program starts when a user selects it. If the activity assigned to this worklist starts with such an activity, you can pass command-line arguments to the external program from the worklist record.

For example, if you map a filename to the `COMMAND_PARM` field, the system appends the file name to the command line of the external program (as specified in the step definition).

4. Add fields to provide descriptive information in the user's worklist.

If you have a compelling reason, you can add other application fields instead. However, do not add other application fields if you have added the `WORKLIST_DESCR` field; using `WORKLIST_DESCR` automatically stops the worklist from displaying the application fields.

5. Save the record definition using a name that ends with `_WL`.

6. Create a database table using the record definition that you saved in Step 5.

Replicating Worklists

This section provides an overview of worklist replication.

Understanding Worklist Replication

To consolidate worklists from multiple databases, use the worklist replicate process.

This example illustrates the objects used to replicate worklists between two systems. The worklist replicate process depends on the WORKLIST_MSG service operation definition. The WORKLIST_MSG definition must be active and it must have a valid PeopleSoft Integration Broker routing defined for the worklist replicate process to work. This process uses the Worklist Replicate (WF_WL_REPLICATE) component to run the replication process.

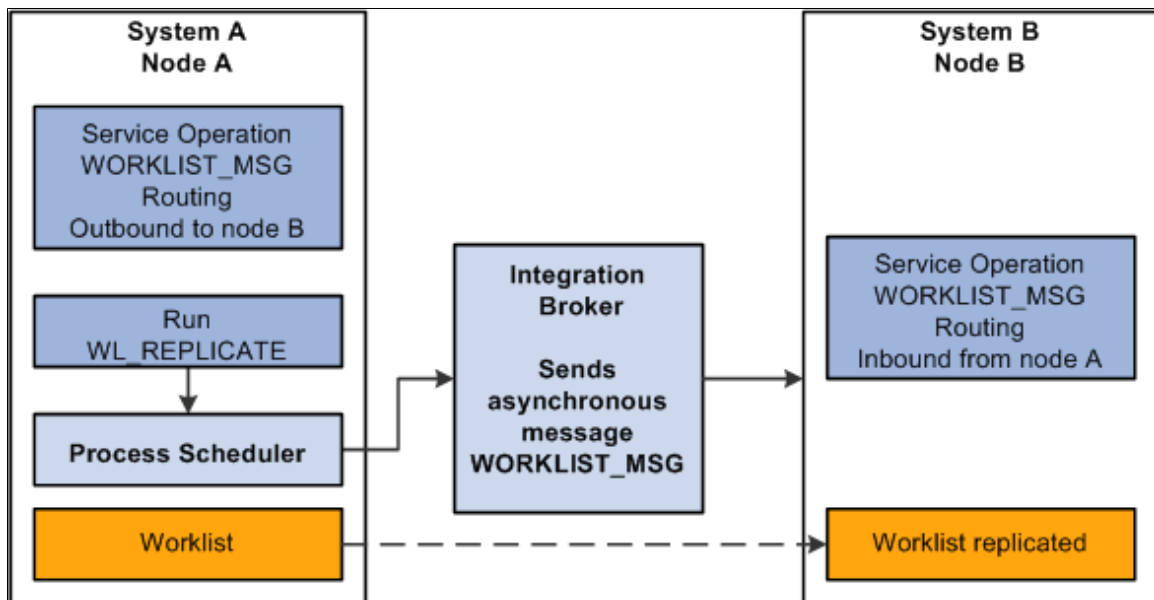

Note: Every worklist item has a worklist name—for example, Expense Report Approval, Order Item, and so on. For worklists to replicate successfully, you cannot generate identical worklist names in multiple databases; one database must be the “master” for each worklist name.

Worklist Replication Considerations

When replicating worklists between databases, keep the following behavior in mind.

This PeopleSoft application formats the **Worked By Activity** field by examining the worklist definition in the target database. If the activity definition is not in the target database, the system cannot format the **Worked By Activity** field. So, in some cases, this field may appear blank after replication, and as long as the WORKEDBYACTIVITY is not defined in the target database, this field is blank. These are the solutions to this problem:

Database Version	Solution
Databases at the same release level (8.4x to 8.4x)	From the source database, export the replicated worklist definition (activity) and the worked-by activity (if they are not the same). Import the definitions into the target database.
Databases at different release levels (8.1x to 8.4x)	Manually recreate the activity in the target database.

Note: If the worklist status in the source database has been changed to complete or canceled, the target database status will not change until the next replication run. In this case the target database may show the worklist as available but will not find it when clicking the link.

Setting Up Worklist Replication

Before you run the worklist replication process, you must activate the service operation WORKLIST_MSG and add the appropriate routings on both the source and target system.

To activate the service operation and add a routing:

1. Select PeopleTools, Integration Broker, Integration Setup, Service Operation Definition.
2. Search for and select WORKLIST_MSG.
3. Make sure the Active check box is selected in the Default Service Operation Version section
4. Click the Service Operation Security link and make sure there is a permission list associated with the service operation. If necessary add a permission list.
5. Select the Routings tab.
6. Enter a value in the Routing Name and click Add.
7. Enter the Sender Node and Receiver Node.
8. Click Save.
9. Click Return.

Note: Integration Broker must be configured.

Running the WL_REPLICATE Process

To run the WL_REPLICATE process:

1. Select PeopleTools, Workflow, Monitor Worklists, Replicate Worklists.
2. Search for an existing run control ID or add a new one.

Use the standard search and add methods to enter a run control ID and access the Worklist Replicate page.

3. Accept the default value or enter the server URL, in the format http://server (protocol://servername), used by the current database.
4. Click the Run button.
5. Click OK.

Checking the WORKLIST_MSG Status

Once the process completes, the service operation WORKLIST_MSG will update the target system with the worklist items. To verify that the service operation was successful, you can check the service operation status in the Service Operation Monitor.

To check the WORKLIST_MSG status:

1. On the source system, select PeopleTools, Integration Broker, Service Operations Monitor , Asynchronous Services.
2. Select the Publication Contracts tab and enter Queue Name WORKLIST_CHNL.
3. Click Refresh.

This example illustrates the fields and controls on the Service Operation Monitor-Publication Contracts page.

Select	Transaction ID	Queue Name	Publishing Node	Sub Queue	Subscriber Node	Segment Number	Service Operation	Service Operation Version	Status	Alias	Time Stamp
<input type="checkbox"/>	1cc6800a-6420-11df-b8c8-a9eb0d7708fc	WORKLIST_CHNL	PT_LOCAL	Sub Queue	PSFT_TRN	1	WORKLIST_MSG	VERSION_1	Done	WORKLIST_MSG.VERSION_1	05/20/2010 3:58:21PM

The publication contract should have a status of Done. You can click the Details link to view additional details or review the actual XML message that was sent.

4. On the receiving node, sign on and view the worklist.
5. If the worklist does not appear on the receiving system, then check the Service Operations Monitor to ensure the subscription contract was processed. Select PeopleTools, Integration Broker, Service Operations Monitor, Asynchronous Services and access the Subscription Contract tab.

Chapter 6

Adding Events and Routings

Understanding Events and Routings

This section lists common elements and provides an overview of events and routings.

Common Elements Used in Events and Routings

<i>Field or Control</i>	<i>Description</i>
Name	Enter a unique name for the system to display in dialog boxes that list routings. By default, the routing name also appears as the display text under the icon on the map.
Icon Descr (icon description)	(Optional) Enter text to appear under the icon if you do not want to use the default name. Include line breaks in the icon display text by pressing Enter .

Events and Routings

When you create a business process in PeopleSoft Application Designer, you specify which activities form a business process and in what order they must be completed. The map provides an overview of the process, but it doesn't provide a link between the activities. To link the activities to a workflow, you add routings, which automate the delivery of information to other activities and other users.

Events are conditions that have associated routings. Define the condition in PeopleCode, which is attached to the record definition underlying a step in a step map. When a user saves the page, completing the step, the system runs the PeopleCode program to test the condition. If the condition is met, the system performs the routings.

Routings can deliver data in two forms: worklist entries and email messages. To create a routing, specify the routing type, who should receive the data, and which data you want to send. The data is usually a subset of the data from the step that triggers the routing.

Adding and Defining Events

This section discusses how to add and define events in PeopleSoft Application Designer.

Adding an Event

To add an event:

1. Open the activity to which you want to add the event.
2. Click the **Event** button in the toolbar.
3. Click where you want the event to appear on the map.

The **Event** icon appears on the map.

4. Connect the **Event** icon to the icon for the step that triggers it.
 - a. Click the **Connector** icon in the palette.
 - b. Click the **Step** icon and then the **Event** icon.

An arrow connects the two icons.

Use the **Link** icon, not the **Line** icon, to connect an event to the step that triggers it. If you use the **Line** icon, the system will not recognize the event.

Defining the Event

To define the event:

1. Double-click the **Event** icon, or right-click and select Item Properties.

The Event Definition dialog box appears.

2. Enter a name and description of the event.

<i>Field or Control</i>	<i>Description</i>
Name	Enter the name used to trigger the event with the TriggerBusinessEvent PeopleCode function. By default, the event name also appears as the display text under the icon on the map.
Active	When an activity triggers an event, the TriggerBusinessEvent function determines whether the event is active. To temporarily deactivate an event, preventing any of its routings, clear this check box. To restart an inactive event, select it.
Event Triggered from Record Name	Select the record definition to which you want to add Workflow PeopleCode to trigger the business event.

Editing the Business Rules

To edit the business rules:

1. Click the **Edit Business Rules** button.

The PeopleCode Editor appears. The name of the first key field in the specified record definition appears in the title bar.

Note: The **Edit Business Rules** button adds the Workflow PeopleCode to the first key field in the specified record definition. If you use Virtual Approver, use PeopleSoft Application Designer to add SaveEdit PeopleCode to this same record.

2. Enter the PeopleCode that triggers the business event.
3. Save the PeopleCode.
4. Click OK to close the Event Definition dialog box.

Adding and Defining Worklist Routings

This section provides an overview of adding and defining worklist routings.

Prerequisites to Adding and Defining Worklist Routings

Before you create a worklist routing for an activity, create a worklist record definition. The worklist record determines what fields the system stores for each work item.

See [Creating Worklist Record Definitions](#).

Creating Worklist Routings

To create a worklist routing:

1. Create the business event that triggers the worklist routing.
2. Click the **Worklist** button in the toolbar.
3. Click where you want the **Worklist** icon to appear on the map.

The **Worklist** icon appears.

4. Connect the worklist routing to the event that triggers it.
 - a. Click the **Connector** icon in the palette.
 - b. Click the **Event** icon and then the **Worklist** icon.

An arrow connects the two icons. Use the **Link** icon to connect a routing to an event. If you use the **Line** icon, the system will not recognize the routing.

5. Double-click the **Worklist** icon or right-click and select Item Properties.

The Worklist Definition dialog box appears.

6. Enter a name and description for the worklist routing.

See “Specifying Workflow Settings” (Security Administration).

Defining Worklist Attributes

Define worklist attributes in the Worklist Attributes dialog box.

This example illustrates the fields and controls on the Worklist Attributes dialog box.

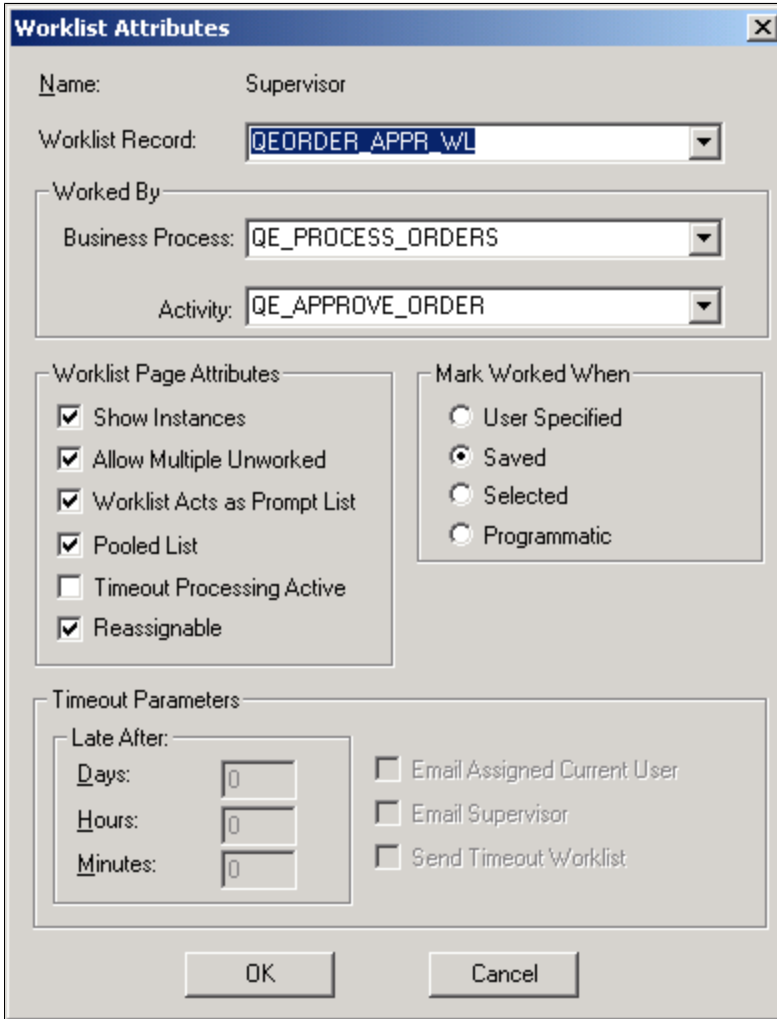

To define worklist attributes:

1. In the Worklist Definition dialog box, click Attributes.

The Worklist Attributes dialog box appears.

2. Select the worklist record, business process, and activity from the appropriate drop-down list boxes.

Field or Control	Description
Worklist Record	Select the record definition to use for storing and displaying work items.

Field or Control	Description
Business Process	Enter the business process name that is associated with the worklist item.
Activity	<p>Enter the activity name that is associated with the worklist item. When a user selects a work item from the worklist, the system displays the page (or external program) that is associated with the first step in the activity that you specify here. The first step is the one marked as Step 1 Path 1 in the step map.</p> <p>You usually select the next activity in the current business process, but this is not required. You can route to any activity in any business process. This is the <i>Worked by</i> business process and activity, which may not be the same as the business process or activity that triggered the worklist.</p>

3. Select worklist page attributes.

Field or Control	Description
Show Instances, Allow Multiple Unworked, and Worklist Acts Like Prompt List	Reserved for future use.
Pooled List	<p>Specifies whether the system creates a single shared work item or one work item for each worklist user. With a pooled worklist, all worklist users receive copies of shared work items; the first user who selects an item works on it, and the item is dropped from everyone else's worklist. With a non-pooled worklist, each user receives a personal copy of each item.</p> <p>If Delete Pooled WL When Select is selected on the Worklist System Defaults page, a pooled worklist will be deleted from other queues when a user selects it.</p>
Timeout Processing Active	Specifies whether the system checks this worklist for overdue items.
Reassignable	Enables users to reassign worklist items to other users.

4. Specify the timeout parameters (if timeout processing is active).

Field or Control	Description
Timeout Parameters	Specifying a timeout condition is optional. If you want all work items to remain in this worklist until a user processes them, leave the controls in this group box blank, or clear the Timeout Process Active check box. Otherwise, specify how long to wait (days, hours, and minutes) for a user to process a work item. The system adds the three values together. If a work item sits in the worklist for longer than the specified amount of time, the system performs the action identified by the check box that you select.
Email Assigned Current User	Send an email message to the user to whom the work item is assigned, warning that the item is overdue.
Email Supervisor	Send an email message to the user's supervisor. The supervisor is assigned as the user's supervising role user in the user profile, maintained through PeopleSoft Security. In PeopleSoft HRMS applications, the system uses the supervisor from the user's PERSONAL_DATA record.
Send Timeout Worklist	Send a new worklist item to the currently assigned user's timeout worklist.

- Specify what the user must do before the system considers a work item to be worked.

Work items remain in a user's worklist until they have been worked.

Field or Control	Description
User Specified	<p>A work item is marked as worked when the user explicitly identifies it as worked by selecting it on the Select Worklist page and clicking the Mark Worked button. This option is useful when the user must return to the same work item several times or wait for supporting information.</p> <p>If the worklist item is replicated from another database, the Mark Worked function is disabled in the target database.</p>
Saved	A work item is marked as worked when the user saves work on the page that is assigned to the worklist. This option is appropriate for work items that the user can complete right away.
Selected	A work item is marked as worked as soon as the user selects it from the worklist. This option is appropriate for work items that notify the user of an event; just seeing the item is sufficient.

<i>Field or Control</i>	<i>Description</i>
Programmatic	A work item is never marked worked directly by the user. It can be marked as worked only with PeopleCode. This setting enables you to provide additional logic to determine when a work item can be considered worked.

Note: Worklists are limited to 999 items. If a user has more than 1000 worklist items in their worklist, the system may not mark the correct worklist item as *Worked* when the user clicks the **Mark Worked** button. Use the Worklist Volume Monitor to monitor worklist volumes.

See [Monitoring Worklist Volumes](#).

- Click OK to close the Worklist Attributes dialog box and return to the Worklist Properties dialog box.

Specifying Field Mappings

Specify field mappings in the Field Map dialog box.

This example illustrates the fields and controls on the Field Map dialog box.

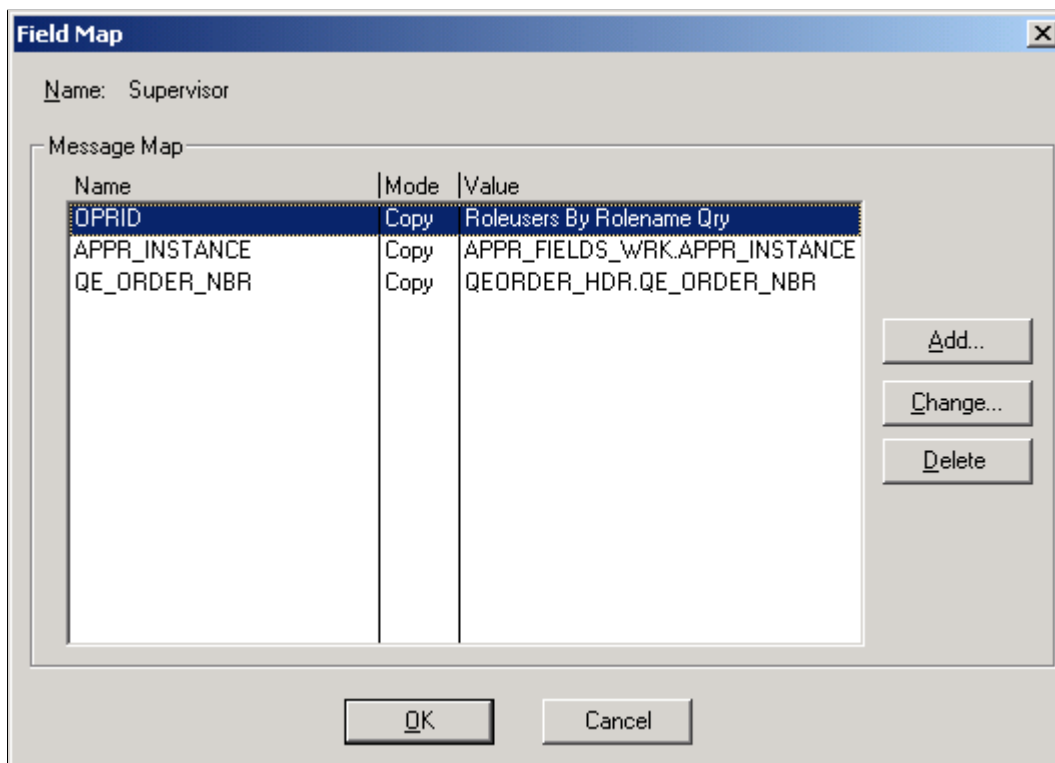

To specify field mappings:

- Click the **Field Mapping** button.

If the **Field Mapping** button is unavailable, then you did not properly link the routing to the event that triggers it.

The Field Map dialog box appears. Use this dialog box to tell the system where to find the data to create a worklist entry. The **Message Map** group box lists the fields involved.

<i>Field or Control</i>	<i>Description</i>
Name	Displays the user ID (OPERID) of the person who receives the worklist routing. It may also display the fields in the worklist record, which includes key data for the page where the user performs the necessary work and the descriptive data that appears in the user's worklist—normally the WORKLIST_URL and WORKLIST_DESCR fields.
Mode	Specify the map mode value from Copy, Xlat-S, or Xlat-L (use one of these two values if the field has a translate table value).
Value	Indicates where the system finds the data to enter into those fields.

2. Select the field to which you want to map a value.
3. Click the **Change** button or, to add a new field to the map, click the **Add** button.

This example illustrates the fields and controls on the Map Field dialog box.

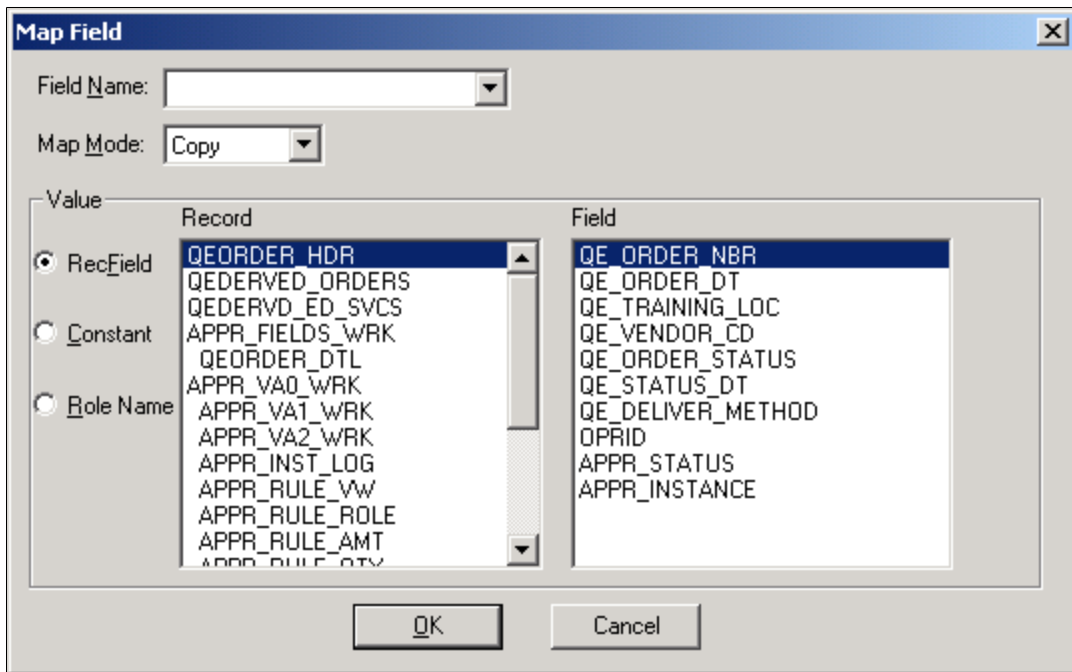

The Map Field dialog box appears. Use this dialog box to provide a value for each field in the worklist record:

1. Select the field into which you want to place routing data.

If you select the field from the message map, its name appears in the **Field** list box. If the correct name does not appear, you can select a field from the list box or enter a new name.

- Identify the value for the selected field.

There are three ways to put data into a field: from a database field, a specific constant value, or a role name.

Field or Control	Description
Record Field Value	To enter the value from a database field into the worklist field, select the RecField option. The Record box lists the record definitions that should be available when the event triggers this routing (according to the page and record definition associated with the event). Select the record name. The fields in that record appear in the Fields list box. Select the field whose value you want. When the event is triggered, the system completes the worklist field with the value of the field in the current record.
Constant	To assign a specific constant value to the field, select this option and enter the value in the text box to the right. Every worklist entry will have this value in the selected field.
Role Name	To assign a role name to the field, select this option and select a role from the drop-down list box that appears next to it. When the event is triggered, the system completes the field with a list of users who fill this role. If you select a user list role, each user who is assigned to that role receives a copy of the work item. If you select a query role, each user that the query returns receives a copy.

- If you map the field to a role name, provide values for any bind variables.

If you map the user ID field to a query role that includes bind variables, the **Specify Query Bind Variables** button appears next to the **Role Name** option. When you click this button, a dialog box appears, enabling you to specify the value that each bind variable in the query should take for each work item.

The Query Bind Variable column displays the bind variables for the role query. (If nothing appears in this column, you defined the query without specifying any bind variables.) The Record column lists the record definitions associated with the component that triggers this routing. The Field column displays the fields in the selected record definition.

You can bind each variable with the value from a record field or with a constant:

- To bind a variable with the value from a record field, select the **Field** option, select the bind variable for which you want to provide a value, and select the record field to contain the value.
- To bind a variable with a constant, select the **Constant** option, and enter the value into the text box.

- When you have mapped bind values for all of the variables, click OK to close the dialog box.

Note: If you are using route controls with Virtual Approver, the role that you assign to the OPRID field is one of the predefined route control query roles.

5. If you map the field to a record field, specify whether the system copies the assigned value directly into the worklist field or replaces the assigned value with a value from the translate table.

Select the appropriate option from the **Map Mode** list box. This list box is available only if the selected field has associated translate table values. In most cases, leave the default value (Copy).

For example, suppose the worklist record definition includes an **Employment Status** field, and you associate the field with the record field PERSONAL_DATA.STATUS. If the PERSONAL_DATA.STATUS field holds an abbreviation that translates to a value in the translate table, you can tell the system to populate the worklist field with the abbreviation (Copy) or with the corresponding translate table value (Xlat-S for the short form or Xlat-L for the long form).

6. Click OK to add the field and its value to the routing dialog box.
7. Repeat Steps 5 through 10 for each field that you want to add to the worklist routing.

You must provide values for all of the key fields in the worklist record definition.

8. Close all of the dialog boxes by clicking OK in each one.

Adding and Defining Email Routings

This section provides an overview of email routings.

Understanding Email Routings

With email routings, you can send email messages in response to business events. In some cases, you might want to define two routings for the same event: one that adds an item to someone's worklist and one that sends an email message to tell that person about the new worklist item.

Email messages can be sent as plain text or rich text format. If you select to use rich text format, you can also include images in the email message. When using rich text format NOTETEXT can be mapped to any rich text enabled edit box field in your application to create a rich text email.

You can send an email routing to anyone to whom you can send email messages through the mail system. PeopleSoft applications support email routings to any email software that supports the Simple Mail Transfer Protocol (SMTP) standards.

Creating an Email Routing

To create an email routing:

1. Create the business event that triggers the email routing.
2. Click the **Email** button in the toolbar.
3. Click where you want the **Email** icon to appear on the map.

The **Email** icon appears.

4. Connect the email routing to the event that triggers it.
 - a. Click the **Connector** button in the palette.
 - b. Click the **Event** icon and then the **Email** icon.

An arrow connects the two icons.

5. Use the **Link** icon to connect a routing to an event.

If you use the **Line** icon, the system will not recognize the routing.

6. Double-click the **Email** icon, or right-click and select Item Properties.

The Email Definition dialog box appears.

7. Enter a name and description for the routing. By default, the routing name also appears as the display text under the icon on the map.

Note: The name can not contain any special characters, such as dash (-), dollar sign, number sign or question mark. Spaces and underscore are permitted.

8. Select any settings to apply to the email message.

The options in this dialog box correspond to the mailing options offered in most email software. If your email software does not support one or more of these options, the system ignores its setting.

See the documentation for your email software.

9. Click to return to the Email Definition dialog box.

Note: When designing workflow, consider the following behaviors of email routing: Calling `TriggerBusinessEvent PeopleCode` in workflow is part of process of saving, so any failure of `TriggerBusinessEvent` results in a failure to save. If an email route exists and email failed, then the save process will fail and the database transaction will roll back. However, if `TriggerBusinessEvent` successfully sent the email but the saving process failed after the workflow event, then the sent email cannot be rolled back.

Mapping Fields

Map fields for your email routing in the Field Map dialog box.

This example illustrates the fields and controls on the Field Map dialog box. You can find definitions for the fields and controls later on this page.

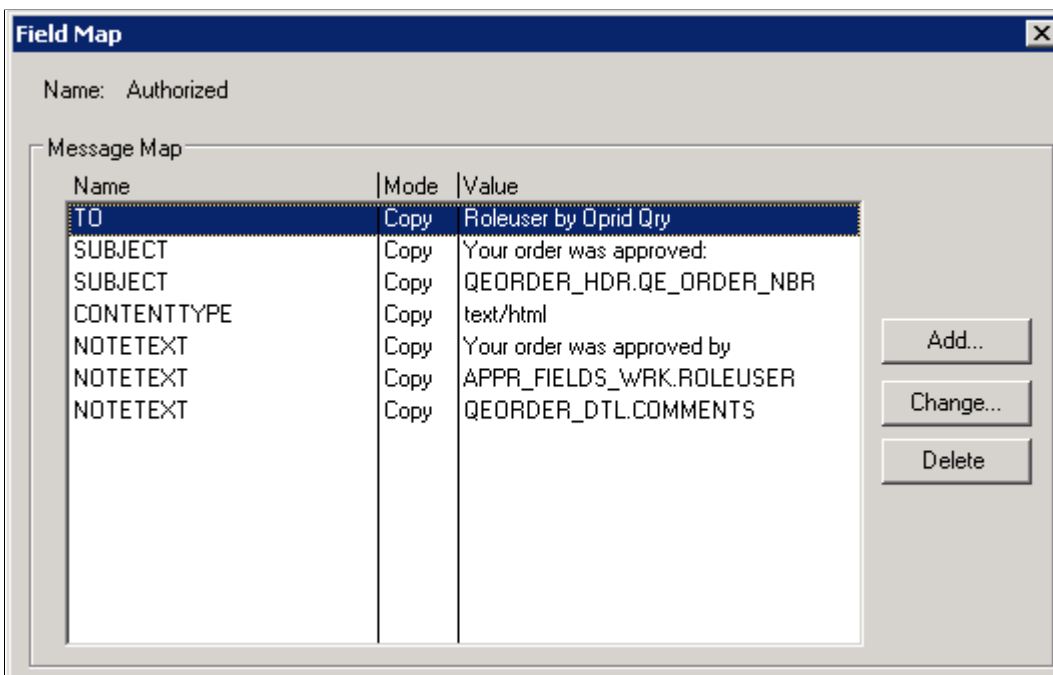

To map fields:

1. Select Field Mapping .
2. The Field Map dialog box appears.

Use this dialog box to tell the system where to find the data to create an email message. The **Message Map** group box lists the fields involved.

<i>Field or Control</i>	<i>Description</i>
Name	Displays the fields.
Value	Indicates where the system finds the data to enter in the fields.

The fields that appear in this dialog box represent the two different types of data that are needed to create an email message: who and what. That is:

- Who receives the email message?
The TO field holds the email address for this person.
- What is the content of the email message?

This includes a SUBJECT line and any additional text that you add. You can also concatenate data into the message. When you first open the dialog box, the Name column displays the fields available for mapping. You must provide a value for the TO field.

3. Select the field into which you want to map a value.
4. Click the **Change** button or, to add a new field to the map, click **Add**.

This example illustrates the fields and controls on the Map Field dialog box.

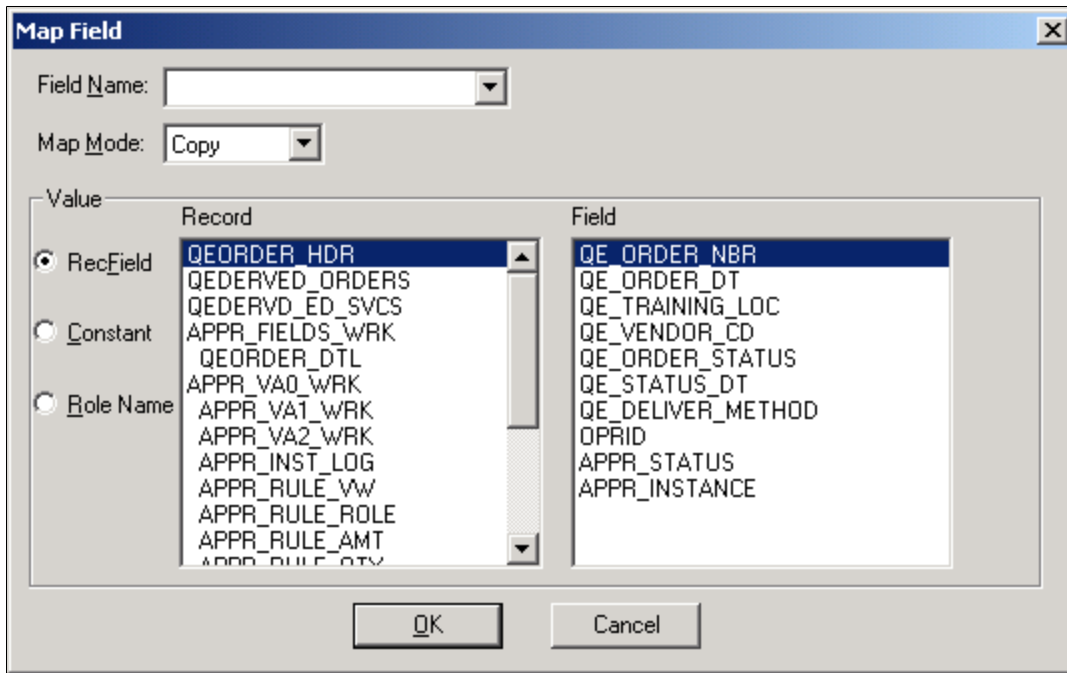

The Map Field dialog box appears. Use this dialog box to create the email message from the values provided by the step that triggers the routing:

1. Select the field into which you want to place routing data.

If you select the field from the message map, its name appears in the **Field** list box. If the correct name does not appear, you can select a field from the list box or enter a new name.

The following fields in an email routing's message map have specific meanings to the email software to which the system forwards the email message.

<i>Field or Control</i>	<i>Description</i>
TO	<p>Indicates the name of the person to whom you want to send the email message. The value can be an email name or a role. To send to more than one person, separate the names with semicolons. The values in the TO, CC, and BCC fields determine who receives the email message. The values that you map to these fields can be email addresses, role user IDs, or role names. The system automatically converts role user IDs and role names into the users' email addresses.</p> <hr/> <p>Note: At least one TO Recipient is Required on all email sent.</p> <hr/>

Field or Control	Description
FROM	(Optional) Indicates the email address of the sender. Setting this value overrides the system SMTPSender value so that the recipient of the email message can reply to an individual, rather than to the system email address.
REPLYTO	(Optional) Indicates the email address to which the sender recommends sending replies.
SENDER	(Optional) Indicates the email address of the actual originator of the email if different from the address set in the FROM field.
CC and BCC	(Optional) Indicates the names of other people to whom you want to send the message.
SUBJECT	Indicates the subject line that appears in the receiver's email inbox.
NOTETEXT	Indicates the body of the message. The message can have multiple NOTETEXT fields. The system displays NOTETEXT fields in the order in which they appear in the Field Map dialog box.
CONTENTTYPE	Indicates whether the message will be in plain text format or use rich text. Enter one of the following constants: <ul style="list-style-type: none"> text/plain (default) <p>If you do not include CONTENTTYPE in the field map, the message will be in plain text.</p> <ul style="list-style-type: none"> text/html <p>Allows you to use the NOTETEXT to point to any rich text enabled edit box field.</p>
FILEPATH	(Optional) Indicates the completed qualified path and filename for a file to attach to the email message.
FILENAME	(Optional) Indicates the name to display in the body of the email message, below the icon that represents the file attachment.
FILETYPE	(Optional) Indicates the type of file being attached.

Note: When the PeopleSoft system constructs an email address to be used in email notifications, the system does so according to the following conditions: If the system detects an email address with a value enclosed in angle brackets, as in <email_address>, the system uses that enclosed value. If the system does not detect angle brackets in the email address, the system encloses the entire email value in angle brackets when transmitting the email message.

2. To add a new NOTETEXT line, click the **Add** button in the Field Map dialog box.
3. Select NOTETEXT in the **Field Name** box.
4. Identify the value for the selected field.

The value can be data from a record field, a specific constant value, or a role name.

Field or Control	Description
Record Field Value	To enter the value from a record field into the email message, select the RecField option. The Record box lists the record definitions that should be available when the event triggers this routing (according to the page and record definition associated with the event). Select the record name. The fields in that record appear in the Fields list box. Select the field whose value you want. When the event is triggered, the system completes the email field with the value of the record field in the current record.
Constant	To assign a specific constant value to the field, select this option and enter the value in the text box to the right. Every email message will have this value in the selected field.
Role Name	To assign a role name to the field, select this option and select a role from the drop-down list box that appears next to it. When the event is triggered, the system completes the field with a list of users who fill this role. If you select a user list role, each user who is assigned to that role receives a copy of the email message. If you select a query role, each user that the query returns receives a copy. Although the role returns a list of role users, the system enters the user's email address into the field. There must be an email address in each role user record.

5. If you map the field to a role name, provide values for any bind variables.

If you map the TO, CC, or BCC field to a query role that includes bind variables, the **Specify Query Bind Variables** button appears next to the **Role Name** option. When you click this button, a dialog box appears, enabling you to specify the value that each bind variable in the query should take.

The **Query Bind Variable** column displays the bind variables for the role query. (If nothing appears in this column, you defined the query without specifying any bind variables.) The **Record** column lists the record definitions associated with the component that triggers this routing. The **Field** column displays the fields in the selected record definition.

You can bind each variable with the value from a record field or with a constant:

- To bind a variable with the value from a record field, select the **Field** option, select the bind variable for which you want to provide a value, and select the record field that will contain the value.
- To bind a variable with a constant, select the **Constant** option, and enter the value into the text box.

When you have mapped bind values for all the variables, click OK to close the dialog box.

Note: If you are using route controls with Virtual Approver, the role that you assign to the TO field is one of the predefined route control query roles, and the bind variable values come from a work record that you need to add to the component that is triggering the routing.

6. If you map the field to a record field, specify whether the system copies the assigned value directly into the field or replaces the assigned value with a value from the translate table.

Select the appropriate option from the **Map Mode** drop-down list box. This list is available only if the selected field has associated translate table values. In most cases, leave the default value (Copy).

For example, suppose that you want to include a person's employment status in the email message, so you associate the NOTETEXT field with the record field PERSONAL_DATA.STATUS. If the PERSONAL_DATA.STATUS field holds an abbreviation that translates to a value in the translate table, you can tell the system to populate the field with the abbreviation (Copy) or with the corresponding translate table value (Xlat-S for the short form or Xlat-L for the long form).

7. Click OK to add the field and its value to the routing dialog box.
8. Repeat steps for each field that you want to add to the routing.
9. Close all of the dialog boxes by clicking OK in each one.

Chapter 7

Defining Event Triggers

Understanding Event Triggers

As you define workflow processes, you identify the application pages that trigger business events. Then you must add PeopleCode programs to the pages so that they actually trigger the events. The PeopleCode detects when a business rule has been triggered and determines the appropriate action.

Writing Workflow PeopleCode

This section provides an overview of writing Workflow PeopleCode

Understanding Workflow PeopleCode

To trigger a business event from a page, you add a PeopleCode program to the workflow event in the record definition for one of the tables to which the page writes. For example, to trigger events from the Course Request page, add Workflow PeopleCode to the TRAINING record definition; TRAINING is the record definition with which the Course Request page fields are associated.

If you're triggering business events from a page that includes scrolls, add the Workflow PeopleCode to the record definition at the appropriate scroll level. If, for example, you add it to the record definition that is associated with a level one scroll area, the PeopleCode runs once for each row at that level. A Workflow PeopleCode program can reference record fields from record definitions at the same scroll level or at a lower scroll level. These rules also apply to the SaveEdit PeopleCode for Virtual Approver.

Workflow PeopleCode runs after the user saves the page group and before it updates the database with the saved data. More specifically, it runs after SavePreChange PeopleCode and before SavePostChange PeopleCode. Because SavePostChange PeopleCode runs after Workflow PeopleCode, it does not run if the Workflow PeopleCode fails to finish.

Workflow PeopleCode programs typically review the data in the saved record, then decide which business event to trigger, if any. They all include at least one use of the PeopleCode function that triggers events, or Virtual_Router, a PeopleCode library function that is associated with Virtual Approver, which uses TriggerBusinessEvent internally. The Virtual_Router PeopleCode library function is located in the FieldFormula event of the APPR_VA0_WRK.FUNCLIB_02 record field.

You can add the Workflow PeopleCode to any field in the record definition. For clarity, you can add it to a field that the program itself references. For example, you might add the Workflow PeopleCode that triggers an approval process to the **Approval Status** field.

Using the TriggerBusinessEvent Function

You use this function in every Workflow PeopleCode program.

In components that use Virtual Approver, you do not use these functions explicitly in the Workflow PeopleCode. Instead, you use the `Virtual_Router` PeopleCode library function, which uses these two functions internally.

`TriggerBusinessEvent` triggers a specified business event and the workflow routings that are associated with that event. The syntax is:

```
TriggerBusinessEvent (BUSPROCESS.BusProcName, BUSACTIVITY.ActivityName, BUSEVENT.Bus⇒
EventName)
```

The *BusProcName*, *ActivityName*, and *BusEventName* parameters are the names of the business process, activity, and event from PeopleSoft Application Designer. They are all strings, enclosed in quotes. For example, the following code triggers the Deny Purchase Request event in the Manager Approval activity of the Purchase Requisition business process:

```
TriggerBusinessEvent (BUSPROCESS."Purchase Requisition", BUSACTIVITY."Manager Approv⇒
al", BUSEVENT."Deny Purchase Request")
```

See “`TriggerBusinessEvent`” (PeopleCode Language Reference).

Creating Workflow PeopleCode Programs

Do not use this section for components with Virtual Approver.

The general structure of all Workflow PeopleCode programs is the same:

- Check for the condition under which a business event should be triggered.

This condition is a business rule.

- If the condition is true, trigger the event.

The system automatically determines whether the event is active and, if so, triggers it. If you have deactivated the event, the system does not run it.

A typical Workflow PeopleCode program looks like this:

```
/* Start the Employee Training process for a new course request */
if RecordNew(ATTENDANCE) then
    if COURSE_TBL.INTERNAL_EXTERNAL = "I" then
        /* For internal courses */
        &TEMP = TriggerBusinessEvent (BUSPROCESS."Employee Training",BUSACTIVITY."R⇒
equest Course",
        BUSACTIVITY."Request Course",BUSEVENT."Internal Course Request");
    else
        /* For external courses */
        &TEMP = TriggerBusinessEvent (BUSPROCESS."Employee Training",BUSACTIVITY."R⇒
equest Course",
        BUSEVENT."External Course Request");
    end-if;
```

Cloning Business Processes and Activities

There may be instances when you want to share business processes and activities across applications or portals. This sharing can lead to instance ID overlap in applications, making it difficult to identify different transactions with the same business process name.

Using the CloneBusProc library function, you can clone the business process by providing a new name. This function clones all associated activities, steps, and events for the business process with the new prefix.

Syntax

CloneBusProc(*&old_name, &new_name, &prefixname*)

Parameters

<i>Parameter</i>	<i>Description</i>
<i>&old_name</i>	Name of the business process you want to clone, as string.
<i>&new_name</i>	Name for the cloned business process, as string.
<i>&prefixname</i>	Prefix to be used for the cloned activities, steps and events, as string.

Example

This example code will clone the business process EOAW_APPROVALS, the cloned business process name will be EPRO_APPROVALS. The associated activities, steps and events will contain NEW_ as a prefix to the existing name.

```
Declare Function CloneBusProc Peoplecode WF_FUNCLIB_WRK.BUSPROCNAME FieldFormula;

Local string &oldname;
Local string &newname;
Local string &prefixname;
&oldname = "EOAW_APPROVALS";
&newname = "EPRO_APPROVALS";
&prefixname = "NEW_";
&bReturn = CloneBusProc(&oldname, &newname, &prefixname);
```

Writing PeopleCode for Approval Processes

This section provides an overview of writing PeopleCode for approval processes.

Understanding Approval Processes

Approval processes are a common form of business process. PeopleSoft has simplified the process of defining approval processes by enabling you to define approval rules on an approval rule setmap. You can then choose a tool to read and implement the approval rules from the map.

Using Virtual Approver

As users complete transactions that require approvals, Virtual Approver determines the appropriate approver and sends a workflow routing. As each approver completes the approval, Virtual Approver determines whether additional approvals are needed and, if necessary, sends additional workflow routings.

To trigger Virtual Approver from a page, use two PeopleCode functions in the record definition that is associated with the page:

- Use the `Virtual_Approver` function in the `SaveEdit` PeopleCode.

This function checks the approval rules that you defined in the approval rules sets and determines whether an item must be routed for approval.

- Use the `Virtual_Router` function in the `Workflow` PeopleCode.

This function routes items to the next step in the approval process.

Using the GetApprovers Library Function

The `GetApprovers` function is not a regular PeopleCode function; it is a library function, like `Virtual Approver`. It is located in the `FieldFormula` event of the `APPR_VA0_WRK.APPR_RULE_SET` record field.

The `GetApprovers` PeopleCode function checks an approval rules set and determines the entire list of required approvals at once, so that you can develop custom approval tracking applications.

Using Additional PeopleCode Functions and Variables

You might find the following Workflow PeopleCode functions and variables useful as you begin more advanced workflow development.

GenerateActGuideContentURL, GenerateActGuidePortalURL, GenerateActGuideRelativeURL

These functions generate different types of URLs to the specified workflow activity guide (life event). Generally these functions are used in iScripts for populating application pages that you are generating on your own with HTML.

See “The Generate Functions” (PeopleCode API Reference).

GetWLFieldValue

When you open a page from a worklist (by selecting one of the work items), this function enables you to get the value from one of the fields in the worklist record of the current item. The syntax is:

```
GetWLFieldValue(field_name)
```

The *field_name* parameter specifies the field from which you want the data. It must be a field from the worklist record definition.

See “GetWLFieldValue” (PeopleCode Language Reference).

MarkWLItemWorked

When you open a page from a worklist (by selecting one of the work items), this function marks the current worklist entry as worked. MarkWLItemWorked takes no parameters and can be used only in Workflow PeopleCode.

See “MarkWLItemWorked” (PeopleCode Language Reference).

System Variables

You might want to use these system variables during workflow development. If you did not open this page from a worklist, some variables are blank.

Field or Control	Description
%BPName	The name of the business process for the worklist from which you are currently processing a work item.
%WLInstanceID	The instance ID for the work item that you are currently processing.
%WLName	The name of the worklist from which you are currently processing a work item.

Chapter 8

Using Additional Routing Options

Understanding Route Control Development

This section provides an overview of route control development.

Route Control Development

Additional routing options enable you to define complex, custom routing schemes without writing PeopleCode. Develop route controls in the following order:

1. Define route control types, which identify the factors on which you want to base routings: Business Unit, Department, Vendor ID, and so on.

You can define route control types based on any prompt table.

2. Define route control profiles, which identify ranges of values for route control types.

For example, one route control profile might list the vendor IDs for all software vendors, while another might list the IDs for all office supply vendors.

3. Assign route control profiles to role users.

Assign the Vendors (Software) profile to the clerks who handle software and the Vendors (Office Supplies) profile to the clerks who handle office supplies.

4. When you define the routing in PeopleSoft Application Designer, assign one of the roles that is provided for use with route controls.

Route Control Query Roles

The route control query roles have runtime bind variables that correspond to:

- The route control types to use.
- The values for those types.

For example, the One Route Control Qry (one route control query) rule has four bind variables:

- One that specifies the single route control type to use.
- Two that you map to a value from the page that triggers the routing.
- One that you map to the user list role.

When a business event is triggered, the system decides to whom it should route the work item by:

- Binding the query bind variables using data from the page that triggers the event.

- Running the query, and checking each user's route control profile to determine whether the user meets the selection criteria.
- Routing the work item to the appropriate role users.

Defining Route Controls

To define route controls, use the Route Control Type (RTE_CNTL_TYPE) and Route Control Profile (RTE_CNTL_PROFILE) components.

This section provides an overview of route control definition and discusses how to add and build route controls.

Understanding Route Control Definition

Create route controls using Workflow Administrator. There are two major parts to defining route controls:

- Route control types, which identify the situational factors on which you want to base routing decisions.

For example, to route purchase requisitions to different buyers based on which vendor can supply the requested item, you create a Vendor route control type. Later, you specify with whom each buyer works.

Note: You can create route control types based only on fields that have prompt tables.

- Route control profiles, which specify the range of values within a route control type.

Assign route control profiles to role users to identify the areas on which they work.

Adding Route Control Types

To access the Route Control Type page, select PeopleTools, Workflow, Routings and Roles, Workflow Route Control Types.

To add a route control type:

1. Search for an existing route control type, or create a new one.

The Route Control Type page appears.

When creating a new route control type, use a descriptive name for the factor on which you want to base the route control.

2. In the **Edit Table** drop-down list box, select the prompt table against which you want to validate values.
3. Save this page and repeat the process for each route control type.

Building Route Control Profiles

To access the Route Control Profile page, select PeopleTools, Workflow, Routings and Roles, Workflow Route Control Profile.

This example illustrates the fields and controls on the Route Control Profile page.

The screenshot shows the 'Route Control Profile' page. At the top, the title is 'Route Control Profile'. Below it, the 'Route Control Profile' is 'Business Unit M02-M64'. The 'Description' field contains 'Business Units M02 to M64'. There are two sections: 'Routing Control' and 'Range'. The 'Routing Control' section has a dropdown for '*Route Control Type' set to 'Business Unit'. The 'Range' section has 'From Value' set to 'M02' and 'To Value' set to 'M64'. Both sections have search icons and '+ -' buttons.

To build a route control profile:

1. Search for an existing route control profile, or create a new one.

The Route Control Profile page appears. Use this page to specify the range of values that is associated with a class of users.

2. Select a route control type from the **Route Control Type** drop-down list box.

The route control type specifies the prompt tables to which this profile applies.

3. Specify the range of values from the type's edit table that users with this profile can process.

To provide access to a continuous range of values, select the lowest value in the **From Value** field and the highest value in the **To Value** field. To provide access to a single value, select the same value in both fields. To provide access to two values, add a new row to the **Range** field.

4. (Optional) Assign values for another route control type.

You can assign values for more than one route control type to the same route control profile. With your cursor in the **Route Control Type** field, click the **Add** button. Select a new route control type. Assign its authorized values.

5. Save the page.

Using Route Control Roles

This section provides an overview of route control query roles and discusses how to define routings in Application Designer.

Understanding Route Control Query Roles

When you use route controls, the application-specific data that you use to control routings is stored in database tables, not in PeopleCode or query definitions. To change the way that you route items, you update the route control tables using Workflow Administrator pages. You don't have to modify code or business processes.

To preserve this advantage, you use a set of predefined query roles that are designed for use with route controls. The five route control query roles differ only in how many route control types you can use:

- One Route Control Qry.
- Two Route Controls Qry.
- Three Route Controls Qry.
- Four Route Controls Qry.
- Five Route Controls Qry.

Role queries do not include application data (that is, the names of particular route control types or particular values). Instead, they have a series of runtime bind variables that you link to the route control types that you want.

Sample SQL of Role Query

This is the SQL for the Two Route Controls Qry role:

```
SELECT A.ROLEUSER
      FROM PS_RTE_CNTL_LN_VW2 A
     WHERE A.ROLENAME = :1
           AND A.RTE_CNTL_TYPE_1 = :2
           AND A.RTE_FROM_VALUE_1 <= :3
           AND A.RTE_TO_VALUE_1 >= :4
           AND A.RTE_CNTL_TYPE_2 = :5
           AND A.RTE_FROM_VALUE_2 <= :6
           AND A.RTE_TO_VALUE_2 >= :7
```

Like all role queries, this query selects role users (although it retrieves the field from a special route control view, rather than the ROEXLATOPR table).

Notice how generic the WHERE clause is and how many runtime bind variables it includes. This structure enables you to use the same role, regardless of which route control types you are using. The RTE_CNTL_TYPE bind variables enable you to plug in route control types at runtime.

A route control query has two classes of bind variables:

- RTE_FROM_VALUE and RTE_TO_VALUE bind variables are set to values that come from the component that triggers the routing.

They are similar to the bind variables that all role queries have. They enable the role to route items to different users based on some aspect of the item.

- ROLENAME and RTE_CNTL_TYPE variables are typically set to constant values, representing the role and route control types that are relevant for the current routing.

Note: The value for the ROLENAME bind variable should be a user list role that corresponds to a level in your organization. If you're using route controls, you must have a set of organizational roles, and each role user should be assigned to at least one role. PeopleSoft provides a default set of roles—EMPLOYEE, MANAGER, and so on—but you might need to update them to reflect your organization.

Defining Routings in Application Designer

To define routings in PeopleSoft Application Designer:

1. Map the OPRID field (or the TO field for email routings) to the route control query that uses the number of route controls that are relevant for the routing decision.
2. In the Specify Query Bind Variables dialog box, map the RTE_FROM_VALUE and RTE_TO_VALUE bind variables to fields from the page's record definitions.
3. Map the ROLENAME and RTE_CNTL_TYPE variables to constant values that provide the name of a user list role and route control type.

To experiment with how the route control queries work, the Review Role Users page enables you to mimic their operation.

Reviewing Role Users

To review role users, use the Route Control Search (RTE_CNTL_SRCH) component.

This section provides an overview of role users and discusses how to search for and review role users.

Understanding Role Users

If you use route controls, at runtime the system determines where to route work items. This feature provides flexibility, but it also creates the possibility that no users meet the criteria for the role. In a purchase requisition role query, for example, you might want a role query that returns the buyer that is assigned to work with the vendor of the ordered item; if someone orders an item from a new vendor, the query might return no one.

The Review Role Users (RTE_CNTL_SRCH_1) component enables you to search for role users based on specified criteria. Use this page to determine which users receive particular work items. This is useful when using route controls. By entering different values for the route control parameters, you can verify that the correct users are receiving the correct work items and that you've assigned a user for every possible case.

Searching For and Reviewing Role Users

To search for users meeting specified criteria:

1. Sign on to PeopleSoft Pure Internet Architecture and select PeopleTools, Workflow, Routings and Roles, Review Routing by Role Users.

The Criteria page appears. All of the fields are optional. For a complete list of role users, leave them all blank. To list all of the users in a role, select a role but leave the **Route Control Type** boxes blank.

2. Specify a user list role in the **Role Name** field.
3. Specify which route control values to use.
 - a. In each of the **Route Control Type** fields, select a route control type that you defined.
 - b. In the corresponding **Value** field, select a value from the prompt table that is associated with the route control type.
4. Click the **Search** button.

The system searches for role users who meet the specified criteria. It displays the number of users below the button.

5. Access the User List page to review information about the users who meet the criteria.

In the **Users** list, click the down button to expand or collapse the list of users. If there are multiple users, either review them one at a time using the controls in the Users bar or list all of them together by clicking **View All**.

For any user in the list, click the **Detail** button to populate **User Details**. The **Details** button is visible only when the list of users is expanded.

The following table defines the terms on the User List page:

Field or Control	Description
Descr (description), User , and Email ID	Displays the user's name, ID, and email address.
Routing Preferences	Displays the places where the system can deliver work items to this user. Only selected options are available; users cannot receive work items using options that are not selected.

Chapter 9

Using Batch Workflow Processing

Understanding Workflow Batch Processes

When you are working with PeopleSoft applications, you perform some activities interactively (online processes) and the system performs some behind the scenes (batch processes). Batch processes provide three major benefits:

- You can schedule them to run later, on a recurring schedule.
- They can process a large number of items all together, unlike online processes, which typically process one item at a time.
- You can transfer processing to a server so that time-consuming tasks don't monopolize your machine.

However, batch processes have one drawback: they connect to the database directly, rather than working through the PeopleSoft pages. If your application validates incoming data or runs custom PeopleCode, you might not want a batch process updating the database in this way. Also, because you trigger business events by saving data on a page, batch processes cannot initiate a workflow.

You can use Application Engine programs or a component interface to work around these limitations. Like online processes, Application Engine programs enter data through PeopleSoft pages (using a component interface as an intermediary). Like batch processes, they can handle a batch of items.

For example, suppose a batch process transfers assets between departments, and you want to notify (using an email message) the managers of all affected departments. The batch process cannot trigger an email routing, and to create the email messages manually is time-consuming. Instead, after the batch process is complete, you can run an Application Engine program that selects the transferred assets and sends an email message to each manager. You can also replace the batch process with an Application Engine program that makes the asset transfer.

Understanding Batch Workflow Applications

This section provides an overview of batch workflow applications.

Workflow Batch Processing

For an Application Engine program to trigger a business event, it must pass its data to a component interface, and the component interface must then trigger Workflow PeopleCode in a component. Therefore, to set up batch processing, you must set up all three stages of the process:

1. Create the Application Engine program that queries the database.
2. Define a component interface that maps the results to a page.

You decide whether to enter new data on a page. For example, you can create a separate table for tracking overdue invoices. Alternatively, you can use the Save method in the component interface to force PeopleCode to run without entering data on the page. In this case, you set up PeopleCode in your main invoice record and use the component interface Save method to run that PeopleCode when the invoice is overdue (without affecting the data).

3. Create the Workflow PeopleCode that triggers the appropriate business event.

Database Monitoring with PeopleSoft Application Engine

Usually, a user entering data on a page triggers a business process. For example, in a purchase order approval process, the system generates an approval request when a user enters a new purchase order. This immediate response is part of the productivity gain that PeopleSoft Workflow provides.

However, you might want to trigger routings based on an event that doesn't involve a user; for example, when the number of outstanding work item entries becomes too high, a contract lapses, PeopleSoft Process Scheduler completes a batch process, and so on. Application Engine programs make such routings possible.

Events Triggered with Component Interfaces

Application Engine programs do not trigger business events directly. With PeopleSoft Workflow, you trigger business events by entering (and saving) data on a PeopleSoft page that has Workflow PeopleCode associated with it.

Application Engine programs trigger business events indirectly, by passing the results of their queries to the component interface. If the component has associated Workflow PeopleCode, a business process is triggered when the component interface saves the page.

If an Application Engine program returns multiple rows of data, for example, if it finds several overdue item, the agent passes the rows to the component interface one row at a time.

Understanding Database Agents Conversion

Database Agents were used in previous versions of PeopleSoft to perform batch processing. If you implemented Database Agents, convert them to use the most recent technology offered by PeopleCode and Application Engine.

Here are some additional guidelines to consider if you are converting an existing database agent:

- Duplicate the database agent behavior using PeopleCode.

The database agent behavior is determined through its properties, so using PeopleCode to produce this behavior provides greater flexibility because you have all of the capabilities of PeopleCode functions, including the PeopleCode debugger.

- The Field Mapping dialog box for the database agent contains all of the information that you need to set the component interface properties.

- If the component interface has multiple levels, use the level mapping information in the database agent property dialog box to determine how to handle matching and non-matching rows in the component interface level data.

Use the `ItemByKey` method to help determine whether you have matching rows.

Understanding the Notification Application Class

This PeopleSoft application provides a method for sending email messages from PeopleCode through the Notification application class. The Notification application class can be called from Application Engine PeopleCode or from component, page, and record PeopleCode.

Here are some guidelines for deciding when to use the Notification application class instead of calling a component interface to use `TriggerBusinessEvent` PeopleCode:

- To leverage existing business logic on a page, use a component interface.
- If you have already defined a business process, activity, roles, and routing for sending the email message or worklist, use a component interface.
- To send an email or worklist notification (for example, if you want to run an Application Engine program that selects the transferred assets and sends an email message to each manager), use the notification application class.

This assumes that the list of user IDs or email addresses to which you want to send the notification is easy to determine in PeopleCode.

Creating Batch Workflow Applications

This section provides an overview of how to create batch workflow applications.

Understanding Batch Workflow Applications

To create batch workflow applications, you must be familiar with PeopleSoft Application Designer, and you must understand how to create Application Engine programs, component interfaces, and workflow applications.

This section provides a high-level overview of the process.

Creating Batch Workflow Applications

To create batch workflow applications:

1. Create the workflow application.

Build workflow maps, events, routings, and `TriggerBusinessEvent` PeopleCode. Everything must be working for a batch program to trigger the workflow event.

2. Create a new record to use as the state record for the new Application Engine program. This record type can be either derived or a table.

Note: If you are converting a database agent (a technology used in previous PeopleSoft versions), this record contains the database agent input and output fields, that is, the fields on the page where you ran the database agent and the fields that were returned by the database agent query.

3. Create a new Application Engine program.

Define the state record that you created in step 1 as the default state record for the Application Engine program. Insert a SQL statement to select values from the run control record into the state record. PeopleSoft Application Engine automatically initializes the OPRID and RUN_CNTL_ID fields.

4. Create a step in the Application Engine program to select data that meets your conditions.

This step consists of a PeopleCode program with a SQL query that selects the data. For example, if you are looking for invoices that are over a month old, write a SQL query to select the appropriate invoices.

You might want to break the SQL query into separate statements if the data is passed to a component interface with multiple levels.

Note: If you are converting an existing database agent (a technology used in previous PeopleSoft versions), in most cases you can paste the SQL from the database agent query into the Application Engine statement with only minor modifications.

5. Create the component interface for the component with the Workflow PeopleCode.

When you create the component interface, expose the properties that the Application Engine program will update.

Be sure to test the component interface in the interactive environment provided by PeopleSoft Application Designer.

6. Create an Application Engine step that invokes the component interface once for each row that is returned by the query.

How you invoke the component interface depends on what you're trying to accomplish. Here are some general guidelines:

- Remember the mode that you are using for the component. If you are using Add mode, then use the Create and Save methods on the component interface. If you are using Update/Display mode, use the Get and Save methods on the component interface.
- On the Save method, you should record errors to a file or record. Workflow PeopleCode triggers routings when the component successfully saves.

7. Create a process definition for the new Application Engine program and link to the run control page.

The steps for scheduling an Application Engine program are the same as those for any PeopleSoft Process Scheduler process:

- a. Define a process type definition.

PeopleSoft ships with the process types for PeopleSoft Application Engine already defined, so you can bypass this step.

- b. Create a process definition.
- c. Set up the page and component where users will run the process.

If the program includes runtime bind variables, the page must include fields where users can enter values for the variables.

8. Users can then schedule the process just as they schedule any process:
 - a. Navigate to the page.
 - b. Click the **Run** button to reach the Process Scheduler request page.
 - c. Click Run to initiate the process.
9. Test the application.

Monitoring the Database with PeopleSoft Application Engine

To trigger routings based on a nonuser-initiated event:

1. Write a SQL program that checks the database for data that must be processed.
2. Put the SQL program into an Application Engine program.
3. Use PeopleSoft Process Scheduler to schedule the Application Engine program to run on a regular schedule.

When the condition for which you're checking is true, the Application Engine program sends the data to the component interface, which initiates a workflow event. After you've started the Application Engine program, no user intervention is required.

Defining Approval Processes

Understanding Approval Processes

Approval processes are a common form of business process. The approval steps that you place on the approval rule set map represent the approval levels that are required for the activity.

A typical approval process incorporates many business rules, for example:

- Employees can approve purchases up to a given amount, based on their level in the organization: supervisors can approve up to 500 USD, managers up to 5000 USD, and so on.
- All product improvement requests are approved by both a manufacturing representative and a safety inspector.
- People can approve items for their own departments only.
- If an item requires a vice president's approval, bypass the usual step of manager approval.

Business rules like these are usually incorporated into Workflow PeopleCode programs. Logical statements in the PeopleCode check the data on the page, such as the page where employees enter purchase requests, to determine whether the conditions are right for entering a work item into the workflow.

With approval rule sets, you define approval rules on a graphical map.

Features That Are Common to Virtual Approver and GetApprovers

Virtual Approver and GetApprovers PeopleCode share the following advantages:

- You can determine the appropriate approver for each approval step.
- You define and configure approval rules using the same PeopleSoft Application Designer interface that you use to develop all business process maps.
- You can define different approval rules for different business processes and multiple sets of rules for the same process.
- You can build multistep approval processes, with steps occurring sequentially or in parallel.
- You access the approval rule set through built-in PeopleCode functions.

Virtual Approver uses the functions `Virtual_Approver` and `Virtual_Router`. `GetApprovers` is a PeopleCode function. In both cases, the functions use the approval rule set to determine whether approvals are needed and who the appropriate approvers are. To change a rule, you change the approval rule set rather than the PeopleCode.

- Users enter transactions by entering data onto a PeopleSoft application page.

When they save a page, Virtual Approver or GetApprovers checks the approval rules that you’ve defined to determine the necessary approvals.

Differences Between Virtual Approver and GetApprovers

Virtual Approver and GetApprovers PeopleCode differ in significant ways. Use the information in the following table to decide which is appropriate in a given situation:

<i>Virtual Approver</i>	<i>GetApprovers</i>
The system determines the next approver (if any) at each step along the way.	The entire approval chain is determined at the beginning.
Because Virtual Approver processes only one approval step at a time, the system always has the latest data about any substitute approvers, for example, when someone goes on vacation or leaves the organization.	Because the entire approval chain is determined at the beginning of the process, you capture the approval chain at a single point in time. If an approver goes on vacation and schedules a substitute approver, GetApprovers isn’t aware of this.
Because the system determines the next approver (if any) at each step along the way, you can’t show users all of the approvals that are required for a transaction.	Because the entire approval chain is determined at the beginning, you can expose that data on a page that users can see.
Virtual Approver, with Virtual Router, generates workflow routings to approvers.	GetApprovers does not notify approvers. After it provides the list of approvers, you must build a custom approval application. Typically, you store the list of approvers as part of the transaction (usually in a child table), so that the entire approval chain can be viewed. Additional development is necessary to define how approvals occur.
Virtual Approver automatically displays a message to a user who enters a transaction that requires approval. The user can submit the transaction for approval or cancel the transaction.	By itself, GetApprovers does not provide information to the user. You must provide messages.

Note: Because GetApprovers returns only a list of approvers, it can be used with Virtual Approver without disrupting normal Virtual Approver functionality. You might use GetApprovers and Virtual Approver together to add forecasting capability to Virtual Approver.

Understanding Virtual Approver

This section provides an overview of virtual approver.

Virtual Approver

Approval rule sets are PeopleSoft Application Designer definitions that are similar in appearance to workflow maps. Approval rule sets reference business processes, but they are not embedded within business processes (unlike activities, which are part of business processes). That is, approval rule sets are not represented by physical icons on workflow maps.

Instead, approval rule sets are separate definitions that are referenced by Workflow PeopleCode. Specifically, Virtual Approver finds the next approver by calling `Virtual_Approver()` and then sends that person a workflow notification by calling `VirtualRouter()`. You use different PeopleCode to trigger Virtual Approver than you use for other workflow events, but the function of the PeopleCode is the same: to identify the next users and to send them notifications.

To examine how Virtual Approver fits into PeopleSoft Workflow, consider a business process for ordering supplies. The first two activities within this business process are for creating orders and approving orders.

The Create Order activity consists of a single step: entering the order information into the PeopleSoft system.

When an employee enters an order, PeopleCode triggers Virtual Approver, which reads the specified approval rule set to determine whether the order requires approval and, if so, who must approve the order. When an order requires approval, Virtual Approver sends a routing to the approver. The approver works on the item using the activity that is specified in the first step of the approval rule set—in this case, the Approve Order activity.

The Approve Order activity also consists of a single step: approving the requisition. The approver can approve the order, deny the order, or recycle the order back to the original requestor for changes.

This diagram illustrates an Approve Order activity.

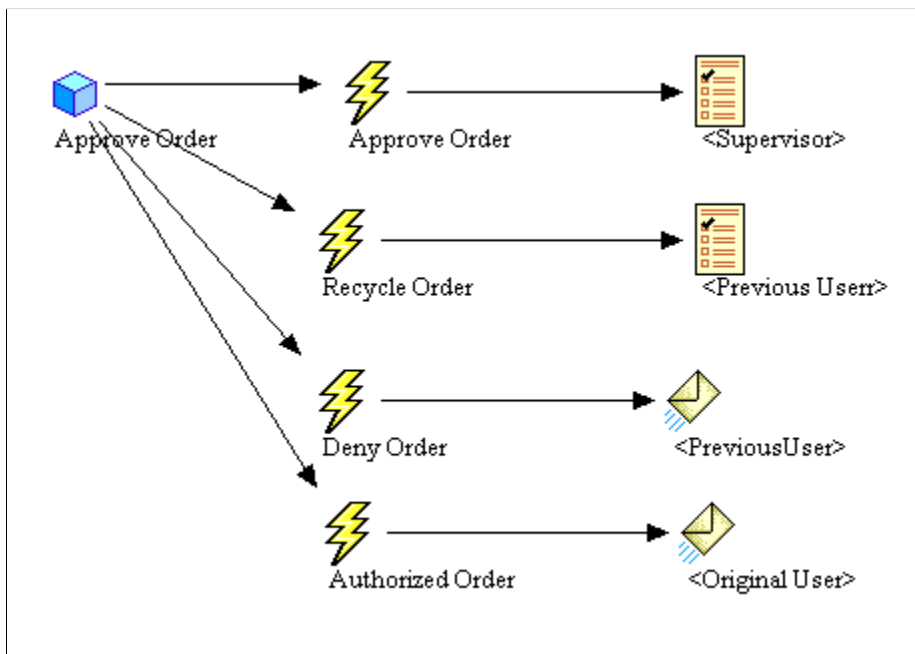

When the approver is finished, PeopleCode again triggers Virtual Approver. Virtual Approver PeopleCode includes a parameter that specifies the approval action. Valid actions are A (Approve), D (Deny), or R (Recycle).

If the approver approves the action, Virtual Approver checks the approval rule set to determine whether additional approvals are required.

- If additional approvals are not needed, Virtual Approver triggers the Authorized Order event, which sends a confirmation email message to the original user and sends a worklist routing to the buyer who places the purchase order.
- If additional approvals are needed, Virtual Approver triggers the Approve Order event again.

This is the same event that was triggered when the original user first submitted the order, but when Virtual Approver determines who must approve the order, the routing goes to the next person in the approval chain.

If the approver denies the order, Virtual Approver triggers the Deny Order event, which sends an email message notifying the original user that the order was denied.

If the approver recycles the order, Virtual Approver triggers the Recycle Order event, which sends an email message telling the person who is defined in the routing (either the original submitter or the previous approver) to change the order and resubmit it.

As you can see, the workflow maps show the events and routings that Virtual Approver triggers, just as the maps show all workflow events and routing. To determine whether Virtual Approver is involved in a particular workflow application, check the SaveEdit and Workflow PeopleCode. If the PeopleCode uses Virtual Approver, you can identify the approval rule set being used.

Virtual Approver Templates

This PeopleSoft application delivers applications with some of the most common approval processes already set up. For example, PeopleSoft Payables uses a Virtual Approver-based business process to streamline voucher processing. In many cases, you must adapt an existing process, rather than develop a new one.

To adapt the approval rules for an existing business process, open the approval rule set for that process and update it with the rules that apply to your business. Because approval rule sets are managed objects within PeopleSoft Application Designer, the PeopleSoft upgrade tools help you manage upgrades. That's the advantage of the table-driven approach to approval processing.

User List Roles for Organizational Levels

Some of the Virtual Approver processes that are delivered with PeopleSoft applications use user list roles that PeopleSoft has already defined: EMPLOYEE, MANAGER, VICE PRESIDENT, and so on. Virtual Approver uses these roles to specify the levels of authorization authority that a user has.

Although PeopleSoft delivers these default roles, you must make sure that the set of roles accurately reflects the levels in your company and that they're assigned to the appropriate users.

Understanding Approval Rule Sets

An approval rule set is a workflow map representing the criteria for determining which approvals are required for a transaction. The components of the map are individual approval steps: one for each level of approval.

Subsequent sections discuss how to:

- Create approval rule sets.
- Define approval steps.
- Maintain approval rules.

Note: The Approval Rule Properties dialog box, Virtual Approver, and some currency-related PeopleCode functions depend on a set of database objects that only exist in an application database. The set of database objects includes: PS_RT_DFLT_VW, PS_RT_TYPE_TBL, and RT_TYPE_LANG. These database objects currently reside in the Common Components project, which is named EO_COMMON. If you require these features to function within the standalone, non-application database, then you must transfer these tables into the database using the upgrade copy feature in Application Designer.

Creating Approval Rule Sets

This section provides an overview of creating approval rule sets.

Except where specified, this process is the same, regardless of whether Virtual Approver or GetApprovers uses the approval rule set.

Creating an Approval Rule Set

To create an approval rule set:

1. In PeopleSoft Application Designer, select File, New.
2. Select *Approval Rule Set* and click OK.
3. Save the rule set and assign an effective date.

Unless you specifically want to make the approval rule set effective at a particular time, use a standard effective date, such as 01/01/1900.

Specifying Approval Rule Properties

This section discusses how to specify approval rule properties.

This example illustrates the fields and controls on the Approval Rule Properties dialog box.

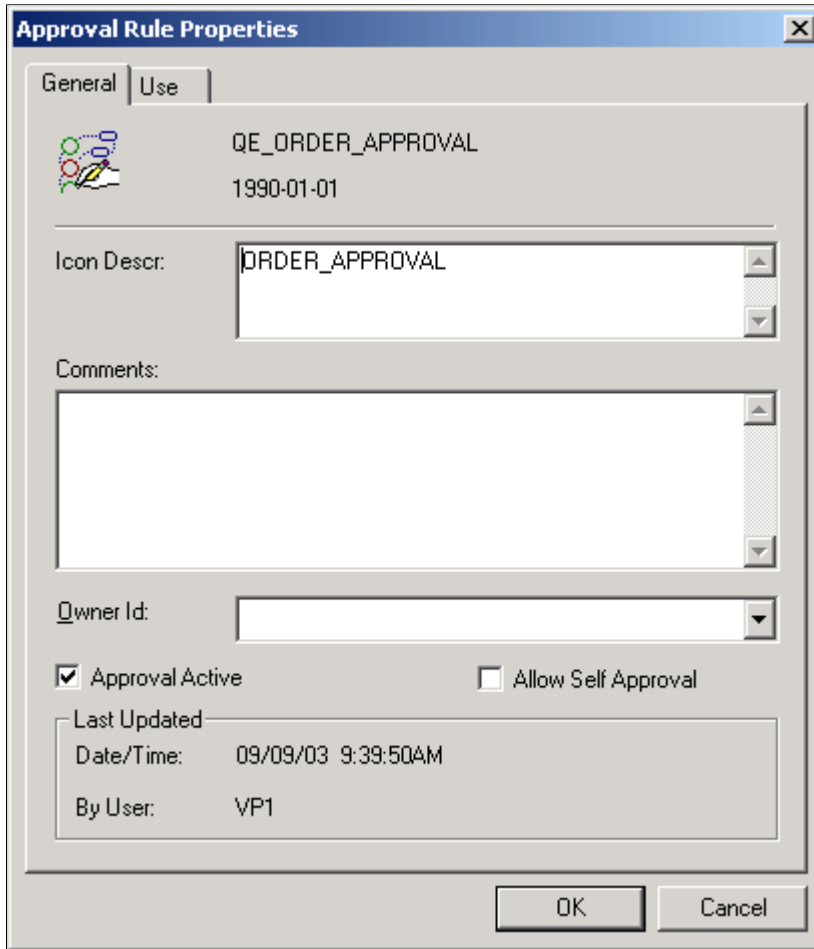

To specify approval rule properties:

1. Open the Approval Rule Properties dialog box by selecting File, Definition Properties.

The Approval Rule Properties dialog box appears, displaying the General tab.

2. Enter descriptive information about the approval rule set.

Use the **Icon Descr** (icon description) field to specify a description that appears next to the rule set's name in dialog boxes that list approval rule sets.

3. (Optional) Temporarily suspend the use of this approval rule set.

Clear the **Approval Active** check box to prevent Virtual Approver from checking the approval rules. Instead, it automatically approves all transactions.

4. Specify whether users can approve their own transactions.

Select **Allow Self Approval** if users are permitted to approve transactions that they entered. Selecting this option does not mean that transactions are automatically approved; self-approval is still subject to the person's approval limits. For example, if managers can approve purchase requisitions up to 5000 USD, then a manager who submits a requisition for 7500 USD cannot self-approve that requisition, even if you allow self-approval.

Specifying Additional Approval Rule Properties

This section describes how to specify additional approval rule properties.

This example illustrates the fields and controls on the Approval Rules Properties dialog box - Use tab.

The screenshot shows the 'Approval Rule Properties' dialog box with the 'Use' tab selected. The 'Business Process' dropdown is set to 'QE_PROCESS_ORDERS'. Under the 'On Authorized' section, 'Activity Name' is 'QE_VA_TEST' and 'Event Name' is 'Authorized Order'. The 'On Currency' section has four empty dropdown menus for 'Currency Code', 'Rate Type', 'Currency Record', and 'Currency Field'. The 'OK' and 'Cancel' buttons are at the bottom right.

To specify additional approval rule properties:

1. Select the Use tab.

Enter the name of the business process that is associated with this rule set.

Although approval rule sets are not represented by physical icons on workflow maps (business processes and activities), the approval process that you're defining is part of a workflow business process. Enter the name of that business process here. This information is required when you use Virtual Approver.

When you add PeopleCode to call Virtual Approver from the transaction page, this business process is one of the input parameters.

2. Specify the event to trigger when all required approvals have occurred.

Note: This information is for Virtual Approver only; the GetApprovers function disregards this information.

In the **On Authorized** group box, enter an activity name (associated with the business process that you've specified) and event name to specify which event should be triggered when the transaction is fully approved. Virtual Approver triggers this event when final approval occurs. For example, after a purchase requisition is approved, it is logical to trigger an event that notifies a buyer that the approved requisition is ready to be fulfilled.

PeopleSoft Application Designer enables you to deactivate individual business events. If you deactivate an event that Virtual Approver is supposed to trigger, the event isn't triggered.

An **On Authorized** activity or event is optional. Try to avoid using the same activity or event as on the individual step's **On Pre-Approved** field.

3. Specify currency units for the approval rules.

Enter currency information only if the approval rules are based on monetary amounts in the transaction.

Enter the currency code and rate type that are used in your approval rules. For example, if a rule requires approvals for amounts over 1000 USD, enter *USD*.

4. Specify the currency unit for the transaction.

Specify the currency record and currency field name that store the currency code for the data to be evaluated. For example, to evaluate whether a requisition requires approval, you must know the amount of the requisition and the currency in which that amount is expressed.

Note: If the currency that is specified for the transaction being processed is different from the currency that is specified for the approval rule, Virtual Approver performs the appropriate currency conversion before making the comparison.

5. Click OK to close the properties dialog box.
6. Add approval steps to the rule set.
7. Save the approval rule set.

Making an Effective-Dated Change to an Approval Rule Set

To make an effective-dated change to an approval rule set:

1. Open the approval rule set.
2. Select File, Save As.
3. Enter the new effective date.
4. Click OK.

Now, a new object with the same name exists, but it has a different effective date. The different effective-dated versions of the rule set appear separately in the dialog box.

5. Modify the rules, as needed.

Defining Approval Steps

This section provides an overview of approval steps.

Understanding Approval Steps

Rule steps are the individual approval steps. Approval rule sets incorporate one rule step for each level of approval that might be required.

When the person who submits something for approval has no self-approval authority, you do not need to include a step for that person. However, you may include a step for that user so that your graphical map more clearly documents the entire process. As long as that user has no authorization authority, Virtual Approver bypasses that user anyway.

If users who submit items for approval have some level of authorization, for example, users can self-approve amounts up to 100 USD. Then, the first rule step must represent that approval level.

Adding a Rule Step to a Rule Set

To add a rule step to a rule set:

Note: This process is the same, regardless of whether Virtual Approver or GetApprovers uses the approval rule set.

1. Click Approval Step on the toolbar.
2. Click the location on the approval rule set where you want the step to appear.

An **Approval Step** icon appears where you clicked.

Defining a Rule Step

This section discusses how to define a rule step:

This example illustrates the fields and controls on the Rule Step Definition dialog box - Definition tab.

To define a rule step:

1. Double-click the rule step icon, or right-click it and select Item Properties.

The Rule Step Definition dialog box appears.

2. Enter an icon description.

Use the **Icon Descr** field to specify a description to appear in dialog box boxes that list this type of map. If you leave this field blank, the map name appears by default.

3. In the **Route to Role** list box, select the role that performs this step.

The role that you select is the role of the user who approves items at this step and path. The system verifies this role against the row-level rule that you set up in a previous step before routing items. Select a user list role that corresponds to a level within your organization. In approval processes, a person's level typically determines the approval authority.

Note: The Virtual Router portion of Virtual Approver determines who should receive the work item based on the role that you specify here, with the query role that is assigned to the worklist in PeopleSoft Application Designer. The worklist's query role must accept a role name as a bind variable, as the standard route control roles do.

- In the **Equally Authorized Roles** field, select all of the roles that are qualified to process the transaction at this step.

For example, consider a purchase request process in which managers can approve transactions up to 25,000 USD. If a manager enters a request for 25,000 USD or less, Virtual Approver automatically approves it. Now, suppose that you also want to allow system administrators to self-approve up to 25,000 USD (if you allow self-approval). All you do is add *SYSTEM ADMINISTRATOR* to the **Equally Authorized Roles** box. System administrators don't receive transactions routed to them, but they are treated as managers for the requests that they submit.

You can also use this field for users who do not normally participate in the approval process, but who have the necessary authority to approve at this level. This can be useful for exception processing, for example, when the regular approver is unavailable or you need to approve a transaction outside the worklist. Be aware that even if an equally authorized user handles the approval, the worklist routing in the regular approver's queue does not disappear.

GetApprovers does not return information about equally authorized roles, only about users who actually perform approvals.

Use the **Add** and **Remove** buttons to add users to or remove users from the **Equally Authorized Roles** box.

- Specify what the user sees when a transaction requires further processing for approval.

When a transaction needs further approval, Virtual Approver can:

- Trigger the specified event to forward the transaction to the next step.
- Display a message to the user, indicating that further approval is required.

- Specify which of these actions Virtual Approver should take by selecting one of the options in the **On Further Processing** box on the right-hand side of the page. The default is **Both**.

Field or Control	Description
Workflow Only	If a transaction needs further approval, Virtual Approver forwards it on to the next step without informing the user.
Message Only	The user sees a message indicating that the transaction needs further approval, but the transaction does not enter the workflow.
Both	Virtual Approver displays a message asking the user whether to add the transaction to the workflow. If you select Message Only or Both , the message comes from the PeopleSoft Message Catalog. Use the Message Catalog setting to specify the set and number of the message that the user sees.

- Specify whether the system can bypass this approval step if additional approval is required.

In the **Skip to Next Step** group box, select when, if ever, the current approver should be ignored:

Field or Control	Description
Yes	If additional approvals are needed, the system always bypasses this approver. Use this option only when role users can self-approve certain transactions but do not ever approve other people's transactions.
No	This approval step is not skipped and the routing occurs, regardless of whether additional approvals are required. This step is omitted only when a prior approver was able to give final authorization.
Only skip if cannot authorize	If additional approvals are needed (that is, this approver does not have final approval authority), the system skips this approver.

- In the **Appr Step** (approval step) and **Appr Path** (approval path) fields, specify which step you are defining.

Approval processes can have multiple steps (in sequence) and multiple paths (in parallel). The purchase request example following this procedure has several steps, but only one path. An example of a process with multiple paths is one in which requests must be approved by the department manager and an office manager before going to a vice president. Here is the sequence of steps and paths in this case:

Step	Path	Route to Role
1	A	MANAGER (DEPARTMENT)
1	B	MANAGER (OFFICE)
2	A	VICE PRESIDENT

In this example, the system sends two worklist entries when a new request comes in: one to the department manager and one to the office manager. When both of the managers approve the request, the system forwards it to a vice president.

Note: The easiest way to determine approval steps and paths is to consult the activity map for the business process for which you are defining approval rules.

Note: The approval step definition allows for up to 99 steps to be available when you are defining an approval process in Application Designer. However, you can enter any step number required.

Note: No mechanism in Virtual Approver exists by which the worklist entry is removed from other parallel approvers when using multiple steps in case of deny or recycle.

Specifying Rule Step Rules

This section discusses how to specify rule step rules.

This example illustrates the fields and controls on the Rule Step Definition dialog box - Rules tab.

Rule Step Definition

Definition Rules Events

Amount Rule:

	Min	Max	Record	Field
1	0.000	5000.000	QEDERVD ED SVCS	QE GRAND TOTAL
2				
3				
4				
5				

Quantity Rule:

	Min	Max	Record	Field
1				
2				
3				
4				
5				

Row Level Rule

Route Control SQL Object

	Route Control	Record	Field
1	Business Unit	QEORDER HDR	QE VENDOR CD
2			
3			
4			
5			

OK Cancel

To specify rule step rules:

1. Select the Rules tab to specify the approval parameters.
2. Specify which transactions the specified role users have the authority to approve.

You can specify which transactions a user can authorize in the following three ways:

- If approval requirements are based on a monetary amount, enter the criteria in the **Amount Rule** group box.

The user can authorize transactions whose monetary amount is between the values in the **Min** (minimum) and **Max** (maximum) fields. The associated record and field specify the record and field containing the amount in the original transaction.

- If approval criteria are based on a (non-monetary) quantity, enter the criteria in the **Quantity Rule** group box.

The user can authorize transactions in which the (non-monetary) quantity is between the values in the **Min** and **Max** fields. The associated record and field specify the record and field containing the quantity in the original transaction.

- If the approval criteria are based on the approver's user data, enter the criteria in the **Row Level Rule** group box.
3. There are two methods of obtaining row level criteria: using a route control or a SQL object.
- If you select **Route Control**, the range of transactions that the user can authorize is determined by the user's route control profile. The system compares the value from the specified record and field with the user's route control profile. If the value is in the range to which the route control profile gives the user access, the user can approve the transaction.
 - If you select **SQL Object**, the range of transactions that the user can authorize is based on other data in the database.

Evaluate the data using a SQL program that you create as an Application Designer SQL object. After you create the SQL object, enter its name next to the SQL Object option. Enter bind variables used in the SQL program in **Record** and **Field**. At most, five record and field binds can be used.

If SQL Object is selected, the worklist defined in the On Pre-Approved activity or event must be consistent with the Operator defined by the SQL Object. Be sure that the Route to Role matches the Operator rendered by the SQL Object.

For example, if you use the PeopleSoft HRMS applications, which store extensive data on reporting relationships within the organization, you can use a SQL object to specify that a manager is authorized to approve only requisitions submitted by people in that manager's department. Using `order_hdr.deptid` as the bind variable, you can use the following SQL program:

```
Select a.oprid from psoperalias a, ps_dept_tbl b where a.emplid = b.empli⇒
d and b.deptid = :1
```

Note: When using a SQL object as a row-level route control in an approval rule set, set the field map for worklist OPRID consistently.

- You can specify more than one authorization rule for any rule other than SQL object. To add additional authorization rules, enter data in multiple grid rows. For example, you can base the routing on more than one route control field. The number in the **Seq** (sequence) field is changed incrementally for each rule that you add. You can also use multiple authorization types for a single step. In this case, the user can authorize only transactions that meet *all* of the specified rules for this step.

Specifying Rule Step Events

This section discusses how to specify rule step events.

This example illustrates the fields and controls on the Rule Step Definition dialog box, Events tab.

To specify rule step events:

1. Select the Events tab to specify which business events are triggered, depending on the action of the approver at this step.

At each step in an approval process, the person reviewing a transaction has three options: approve it, reject it, or send it back to the previous step (recycle). The **Pre-Approved Activity/Event** box specifies what happens when the person approves the request. You can also specify deny and recycle activities and events. For example, if a request is denied, you might trigger an event that sends an email message to the requester.

If you don't select an event for these actions, the system changes the status of the transaction, but doesn't route it anywhere.

2. In the **Pre-Approved Activity/Event** group box, select the business event to trigger when this approver approves the transaction.

For the first step in the process, this is the event to trigger when a user enters a new transaction. For subsequent steps, it is the event to trigger when the user who is performing the current step approves the transaction, but it requires further approval. In either case, the event must forward the transaction to the next step. These settings are required; you must identify a pre-approved activity and event.

Define each event as part of an activity in PeopleSoft Application Designer. Select the activity name in the **Activity** list box and the event name in the **Event Name** box.

Note: Virtual Approver triggers this event when the transaction requires further approval, that is, when the user who approves it does not have sufficient authority to make a final approval, according to the rules that you defined on the previous page. If the user has the authority to approve the transaction, Virtual Approver triggers the Approval Activity/Event for this approval rule set, which you specify in the properties for the overall approval rule set.

3. Specify which events to trigger if the user denies or recycles the transaction.
4. Repeat this entire procedure for each step in the approval process.
5. Click OK to close the properties.

Maintaining Approval Rules

Maintain approval rules using the Approval Step Maintenance (APPR_STEP_MAINT) component.

This section provides an overview of approval rule maintenance and discusses how to maintain approval rule steps.

Understanding Approval Rule Maintenance

Over time, your business rules might change. Perhaps you once required managerial approval for purchases over 100 USD and now you require approval only for purchases over 500 USD.

You can maintain approval rules in the same place that you create them: on the rules tab of the rule step property sheet. If you prefer to expose the rules to your users so that they can update the rules without using PeopleSoft Application Designer, you can use the Approval Step Maintenance page.

Maintaining Approval Rule Steps

To access the Approval Step Maintenance page, select PeopleTools, Workflow, Approvals, Workflow Approval Rule Steps.

This example illustrates the fields and controls on the Approval Step Maintenance page.

The screenshot displays the 'Approval Step Maintenance' page. At the top, it shows the 'Approval Rule Set' as 'QE_ORDER_APPROVAL' and the 'Effective Date' as '01/01/1990'. Below this, the 'Approval Step' is '1' and the 'Approval Path' is 'A'.

The 'Amount Rules' section is active, showing a table with the following data:

Minimum	Maximum	Record	Field
0.000	1000.000	QEDERVD_ED_SVCS	QE_GRAND_TOTAL

The 'Quantity Rules' section is also visible, showing a table with the following data:

From Quantity	To Quantity	Record	Field
0.00	0.00		

To maintain approval rules:

1. Search for an existing approval rule set, approval path, and approval step.

Use the standard search method to identify your approval rule and access the Approval Step Maintenance page.

Note: This page shows only one rule at a time; the page does not provide an overview of how all of the rules fit together in the approval rule set. Therefore, to use this page effectively, users must be able to identify the approval rule sets and their embedded paths and steps.

2. Update the amount rules.

If approval requirements are based on a monetary amount, enter the amount rules.

The user can authorize transactions whose monetary amount is between the values in the **Minimum** and **Maximum** fields.

Note: The **Minimum** and **Maximum** fields support 23.3 decimal precision. That is, 23 digits can appear to the left of the decimal, and 3 digits can appear to the right of the decimal.

The monetary amount that is evaluated comes from the associated **Record** and **Field** fields. Normally you do not change these values on the page, as doing so might require additional modifications that can be made only in PeopleSoft Application Designer.

3. Update the quantity rules.

If approval criteria are based on a (non-monetary) quantity, enter the quantity rule.

The user can authorize transactions whose monetary amount is between the values in the **From Quantity** and **To Quantity** fields.

The quantity that is evaluated comes from the associated **Record** and **Field** fields. Normally, you do not change these values on the page, as doing so might require additional modifications that can be made only in PeopleSoft Application Designer.

4. Review all of the rules.

If you specify more than one authorization rule for any step, users can authorize only transactions that meet *all* of the specified rules.

5. Save the page.

Triggering Virtual Approver Routings

This section provides an overview of virtual approver routings.

Understanding Virtual Approver Routings

After you create approval rule sets, the steps for developing a Virtual Approver approval process are basically the same as for any other business process. You define roles, events, and routings. When you set event triggers, however, instead of using the `TriggerBusinessEvent` PeopleCode function, you use a pair of functions that trigger routings based on the approval rule set that you specify. To access these functions, you must first add special work pages to the component where the event is triggered.

Adding Workflow Work Pages

Every component that uses Virtual Approver PeopleCode must include the pages `WF_FUNCTIONS_01` and `APPR_WRK_01`. These special work pages load several important Workflow PeopleCode functions into memory. For example, if you're using route controls, `WF_FUNCTIONS_01` enables the system to determine which route control types are relevant for the event that you're triggering.

To add work pages to a component:

1. In PeopleSoft Application Designer, open the component.
2. Add `WF_FUNCTIONS_01` and `APPR_WRK_01` to the list of pages in the component.
3. Save the component.

Note: Usually, after adding a page to a component, you use PeopleTools Security to grant users access to the page. However, because `WF_FUNCTIONS_01` and `APPR_WRK_01` are work pages, you do not want users to see them or be able to access them.

Note: The derived/work record APPR_FIELDS_WRK includes the field PREV_ROLEUSER, which is typically used to identify the previous approver if the process is recycled. If your approval process includes parallel paths, note that if the process recycles from the step above the parallel path, PREV_ROLEUSER is the user who approved at the highest path of the previous step. If this person recycles the process again, it will go through the lower path on the same step, then to the prior step. If the process recycles from a parallel step without an approval, then PREV_ROLEUSER is the user who approved the previous step, and the application must take care of the worklist on the other path of this step.

Adding Virtual Approver PeopleCode

PeopleSoft designed Virtual Approver to simplify the PeopleCode that you must write for approval processes. Rather than writing complex PeopleCode programs, you define the approval rules using pages in the Workflow Administrator, then use two simple PeopleCode functions to check those rules.

After you add the Virtual Approver work pages to the component with the page where the triggering event occurs, you must add both SaveEdit PeopleCode and Workflow PeopleCode to the record definition that is associated with that page.

- The SaveEdit PeopleCode uses the Virtual_Approver PeopleCode library function to check the approval rules that you defined in the Workflow Administrator and determine whether an item must be routed for approval.
- The Workflow PeopleCode uses the Virtual_Router PeopleCode function to route items to the next step in the approval process.

Note: The Virtual_Router PeopleCode library function is located in the FieldFormula event of the APPR_VA0_WRK.FUNCLIB_02 record field. The Virtual_Approver function is located on the FieldFormula event of the APPR_VA0_WRK.FUNCLIB_01 record field.

You must add the SaveEdit and Workflow PeopleCode to the same record field.

SaveEdit PeopleCode

This is the general structure of the SaveEdit PeopleCode program:

1. Declare the external workflow functions Get_RoleUser and Virtual_Approver.
2. Set values in the APPR_FIELDS_WRK work record to give the Virtual_Approver function the data it needs to check the approval rules.

Set these values:

- The name of the role user attempting to approve the transaction.
 - The business process and approval rule set that you want Virtual_Approver to use.
 - The approval action that the current user gave to the current work item. The valid status values are A (Approve), D (Deny), or R (Recycle).
3. Use the Virtual_Approver function.

- Set the approval status record field to the value that Virtual_Approver returns: A (Approved), D (Denied), and P (Pending).

Enter the following code exactly as it's shown, replacing the values in angle brackets with the values that are appropriate for your application.

```

/* Declare the Virtual Approver workflow functions */

declare function Get_RoleUser PeopleCode APPR_VAO_WRK.ROLEUSER FieldChange;
declare function Virtual_Approver PeopleCode APPR_VAO_WRK.FUNCLIB_01 FieldForm⇒
ula;

/* Get the role user name for the current user */

&USERID = %UserId;
Get_RoleUser(&USERID, &EMAILID, &FORMID, &EMPLID, &ROLEUSER);

/* Set values in the work record for Virtual_Approver */

APPR_FIELDS_WRK.ROLEUSER = &ROLEUSER;
APPR_FIELDS_WRK.BUSPROCNAME = BUSPROCESS.<BusProcessName>;
APPR_FIELDS_WRK.APPR_RULE_SET = <approval_rule_set>;
APPR_FIELDS_WRK.APPR_ACTION = <approval_action>;
APPR_FIELDS_WRK.APP_ROW_NUMBER = <current_row_number>;

/* Call the Virtual Approver */

Virtual_Approver();

/* Set the application record's approval status field to the value */
/* Virtual_Approver returns */

<status_record_field> = APPR_FIELDS_WRK.APPR_STATUS;
    
```

The variables in this code are:

Field or Control	Description
BusProcessName (business process name)	The name of the business process whose approval rules you want to use.
Approval_rule_set	The name of the approval rule set that you want Virtual_Approver to use to determine whether an item needs further approval.

Field or Control	Description
Approval_action	<p>The approval action to provide Virtual_Approver as input. Usually, <i>approval_action</i> is the name of the record field in which the user sets the approval status. It can also be one of the string constants: P, D, or R.</p> <hr/> <p>Note: If the user specifies the approval action at level 0 on the page, that is, if the user specifies a single approval action for the entire page, it's preferable to include the field APPR_FIELDS_WRK.APPR_ACTION on the page and let the user set it directly. However, this direct approach doesn't work if the user must specify approval actions for each row in a scroll. You must have the user set the action in another field, then transfer the value to the APPR_ACTION field before the Virtual_Approver call.</p>
Current_row_number	<p>The current row number in the scroll. Setting this field is not necessary at level 0.</p> <p>APPR_ROW_NUMBER is only required when Virtual Approver is triggered on a non-level-0 scroll.</p>
Status_record_field	<p>The record field that holds the approval status of the transaction, such as Purchase Request Approval Status.</p>

The user should store the APPR_INSTANCE in the application table and pass it to the Virtual Approver. For example, APPR_FIELDS_WRK.APPR_INSTANCE = <application table>.APPR_INSTANCE. Optionally, the user can also pass the VA_BEHAVIOR_TYPE: APPR_FIELDS_WRK.VA_BEHAVIOR_TYPE = "1". Only the value of 1 is supported. The user can check the field value of APPR_FIELDS_WRK.VA_BEHAVIOR_STATUS after calling Virtual_Approver():

- If the approval process has been denied, the value is 1.
- If the approval process has been completed, the value is 2.
- If the operation is at a lower step that has already been approved, the value is 3.

If the user is on a step that has been approved by another user, the status of the "Resubmit VA Worklist" flag determines whether this is allowed.

See [Setting Workflow System Defaults](#).

Virtual Approver PeopleCode

The Virtual Approver PeopleCode looks like this:

```
declare function Virtual_Router PeopleCode APPR_VA0_WRK.FUNCLIB_02 FieldFormula;
APPR_FIELDS_WRK.APPR_VR_ROW = <scroll_info>;
Virtual_Router();
if None (APPR_INSTANCE) then
    <application record name>.APPR_INSTANCE = APPR_FIELDS_WRK.APPR_INSTANCE;
endif;
```

The *scroll_info* is a number. If you're calling the router from level 0, *scroll_info* is 0; if you're calling it from a scroll, *scroll_info* is the row number of the current row in the scroll. If you're calling from a level 1 scroll, use the CurrentRowNumber PeopleCode function.

The if statement assigns an instance ID to a transaction if it does not already have one.

Reviewing Approval History

To review approval history, use the Approval Instance Log (APPR_INST_LOG) component.

The Approval Instance log in the Workflow Administrator enables you to see the history of a work item as it passed through the steps of the approval process. You can determine which role users reviewed the item, what action they took, and the item's status.

This section discusses how to review approval instances.

Reviewing Approval Instances

Access the Approval Instance Log page.

To review the approval history of a work item:

1. Enter the approval instance ID of the work item in which you are interested.

A work item's approval instance ID is part of its worklist entry. Find it by viewing the worklist entry on the Worklist page (if you have access to the worklist) or by using the Worklist Monitor.

When you enter the approval instance ID, the Approval Instance Log page displays the data for the specified item.

2. Scroll through the steps in the process.

When you first open this page, it displays information about how the work items entered the workflow (step 0, with the status Initiated). Scroll to review information for each subsequent step. The approval instance status for the last available step is the current status of the work item.

Using GetApprovers PeopleCode

GetApprovers PeopleCode determines the entire list of required approvals based on the rules that are defined in an approval rule set. GetApprovers evaluates all approval steps at once so that you receive a complete list of approvers from the entire approval chain.

Typically, you include GetApprovers in the Workflow PeopleCode for the transaction that requires approval.

GetApprovers

Syntax

```
GetApprovers (approval_rule_set, evaluation_fields_rowset, approvers_rowset, approv⇒  
ers_record)
```

Description

The **GetApprovers** function:

- Evaluates each step in the approval rule set.
- Ignores a step when the rules for the step indicate that no approver is necessary.
- Obtains the role users for a step when the rules for the step indicate that an approver is required.

GetApprovers identifies the role users using the method defined in the step: with either a SQL object or a route control.

After every step has been evaluated, the results are returned to the calling program as a rowset object.

Parameters

<i>Parameter</i>	<i>Description</i>
approval_rule_set	The approval rule set name.
evaluation_fields_rowset	The rowset containing the fields that the rules evaluate. The records and fields referenced by the approval rule set must be at the current level, that is, the same level as the call to GetApprovers .
approvers_rowset	A rowset created from the record APPR_USERLIST. GetApprovers adds rows for each required approval.
approvers_record	The name of the record in which the returned approver data is stored.

Returns

Returns a rowset with the following data for each required approver:

- ROLEUSER
- ROLENAME
- STEP
- PATH

GetApprovers also inserts this data into a record that you specify.

Example

```
GetApprovers("ORDER_APPROVAL", GetLevel0(), GetLevel0()(1).GetRowset(Scroll.APPR_US→  
ERLIST), "APPR_USERLIST")
```

Designing Workflow Activity Guides

Understanding Workflow Activity Guides

Workflow activity guides are navigational aids for end users. A workflow activity guide integrates a single map into the related transactional pages. Although workflow activity guides can benefit all users, they are particularly appropriate for guiding untrained users through self-service transactions.

A workflow activity guide appears as a navigation bar across the top of a page. The bar displays each step that is involved in the activity. Clicking a step takes you to the page where you can complete the step; the navigation bar remains visible as you move from page to page.

Note: The term *activity guide* can also refer to a navigational aid that is used within a workcenter. To avoid confusion, in the context of this documentation, we use the term *workflow activity guide* to refer to an activity guide that is specifically used for workflow.

Understanding Workflow Activity Guide Creation

Creating an activity for a workflow activity guide is similar to creating an activity for a workflow application. You create the new activity and add steps corresponding to the pages that make up the activity. You must, however, set a few extra options.

After you create a workflow activity guide, modify the target pages for each step so that those pages display the workflow activity guide.

The pages don't show the workflow activity guide when you use the standard PeopleSoft portal navigational structures. Therefore, your final task is to create a mechanism for users to access the activity.

Creating and Defining Activities

This section discusses how to create and define activities.

Creating an Activity

To create an activity:

1. Select File, New in PeopleSoft Application Designer.

When prompted, select Activity. Save the activity.

2. Select the Use tab from the Activity Properties dialog box.

To open the properties dialog box, double-click in the map (but not on an item in the map).

3. Select **Activity Guide**.
4. (Optional) Select **Automatically sequence steps**.

After you add steps to an activity, you arrange the steps into a logical sequence using connecting arrows, and assign each step a number.

If you select **Automatically sequence steps**, the step numbers (and the path numbers) are automatically assigned when you save. The step and path numbers are based on the order in which you draw the connecting arrows. This is an efficient way to order the steps.

5. Add steps corresponding to the pages that make up the activity.
6. Arrange the steps, using connectors to put the steps in order.

To connect two steps:

- a. Click the **Link** button.
 - b. Click the first step.
 - c. Click the second step.
7. Repeat until all steps are connected.

You have two options when you arrange the steps: sequential or parallel paths. In a sequential path, the steps form one unbroken sequence. When you create parallel paths, the steps appear in the workflow activity guide as a single row, but the user has more flexibility in choosing which step to do. This is because the user can go directly to any step whose immediate predecessor has been finished.

Defining Step Attributes

Define step attributes on the Step Attributes dialog box.

This example illustrates the fields and controls on the Step Attributes dialog box.

To define step attributes:

1. Double-click a step, or right-click and select Item Properties.

The Step Definition dialog box appears.

2. Enter a name and icon description.
3. Enter the step and path numbers for each step.

If you're manually ordering steps, enter a step and path for each step in the activity.

If you're automatically sequencing steps, the step and path number are automatically updated when you save the activity. However, even if you use this feature, check the step and path number after saving to verify that the steps are in the intended order.

4. Select **Attributes**.

The Step Attributes dialog box appears.

5. Indicate that the step is processed by a page.

Select **Page** in the **Processed by** group box of the dialog box. The **External Program** option is not supported for workflow activity guides.

6. Provide directions for starting the page.

Select the page from the list boxes in the **Processing Page** group box.

In the **Action** list box, select the type of activity that the user must perform on the database. When a user selects this step, the system displays the specified page in the specified action mode.

7. Click **OK** to close the Step Attributes dialog box.

Defining Workflow Activity Guide Options

Define workflow activity guide options on the Step Attributes dialog box.

This example illustrates the fields and controls on the Step Attributes dialog box.

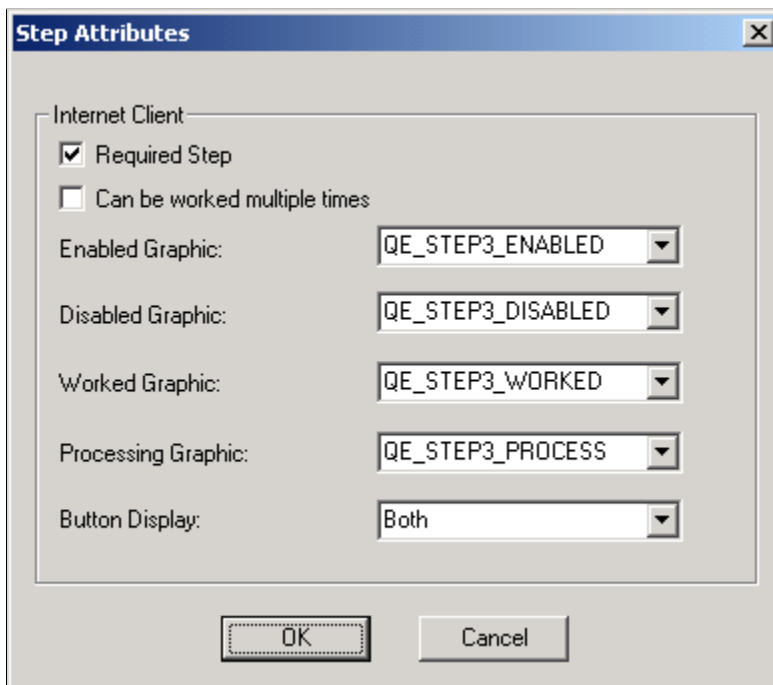

To define workflow activity guide options:

1. Select **Activity Guide**.
2. Configure workflow activity guide options.

Required Step is not currently used by workflow activity guides. However, to create your own programs to enforce required steps, you can use this option to identify them.

Select **Can be worked multiple times** to permit a user to return to an already-worked step. When this option is selected, the workflow activity guide link that opens the step remains active, even after the step is worked. When this option is cleared, the link is unavailable after the user finishes the step.

The button display determines what users see as they use the workflow activity guide.

Field or Control	Description
Link	Select to represent each step with the text that you used as the icon description. This text becomes a link to take the user to the page that is represented by the step.
Graphic	Select to represent each step with an icon. The icons are not links, so if you select this option, the user cannot use the workflow activity guide to navigate between pages. Instead, the user must rely on the Back and Next buttons that appear in related pages. Use this option if you want the Back and Next buttons to be the only navigation objects in the workflow activity guide.
Both	Select to display both icons and links. This is the default option.

3. (Optional) Add graphics to represent the possible statuses of the step.

If you display graphics in workflow activity guides, you must specify which graphics to use. Specify four graphics: one for each possible step status. You can use the same graphic for multiple statuses.

Field or Control	Description
Enabled Graphic	Use for the next step after the step that is currently in process. If you've defined parallel paths, multiple steps can be enabled simultaneously. If you've enabled both graphics and links, the accompanying link is active.
Disabled Graphic	Use for steps that the user cannot yet start. If you've enabled both graphics and links, the accompanying link is inactive.
Worked Graphic	Use for steps that the user has completed. If you've enabled both graphics and links, the accompanying link is inactive, unless you marked the step as one that can be worked multiple times.
Processing Graphic	Use for steps on which the user is currently working. If you've enabled both graphics and links, the accompanying link is inactive.

You can select any graphic in the PeopleSoft image catalog. To use a custom graphic, you must first add it to the catalog.

4. Repeat for each step in the activity.
5. Save the workflow activity guide.

Creating Workflow Activity Guide Pages

This section provides an overview of workflow activity guide pages and discusses how to create workflow activity guide pages.

Understanding Workflow Activity Guide Pages

The pages that are accessible through workflow activity guides are standard PeopleSoft pages. However, for the page to appear in a workflow activity guide, it needs two elements that aren't otherwise present:

- Across the top, a bar displays an overview of all the steps in the activity. In addition to providing information about the activity, this bar provides navigational links to take the user to the pages that are associated with each step.
- **Back** and **Next** buttons appear in the main transaction area. These buttons provide an alternate means of navigating from step to step.

Note: Even after you've added the two workflow activity guide elements to a page, you can continue to keep that page accessible through the regular PeopleSoft menu structure. The workflow activity guide elements aren't visible when the page is accessed that way.

These modifications are visible only when you access the page in activity mode. If you use the PeopleSoft portal navigation, the workflow activity guide modifications are invisible. This enables you to use the same pages in workflow activity guides as you do throughout your PeopleSoft system.

Creating Workflow Activity Guide Pages

To add a workflow activity guide to a page:

1. Open the page in PeopleSoft Application Designer.
2. Add the `ACTIVITY_GUIDE_SBP` subpage to the page.

The PeopleSoft convention is to place the `ACTIVITY_GUIDE_SBP` subpage across the top of the page.

3. Add the `ACTIVITY_NEXT_SBP` where you want the **Back** and **Next** buttons to appear.

The PeopleSoft convention is to place the `ACTIVITY_NEXT_SBP` subpage in the lower, right-hand corner of the page.

4. Save the page.

The two subpages that you've added appear only when a user navigates to the page in workflow activity guide mode. If you navigate to the page in regular page mode, these sections are hidden, and the page looks like it did before the workflow activity guide subpages were added to the page.

Setting Up Access to Pages

This section provides an overview of workflow activity guide page access, workflow activity guide mode, and step status.

Understanding Workflow Activity Guide Page Access

The pages that are accessible through workflow activity guides are standard PeopleSoft pages that you access through the PeopleSoft portal. If you access the pages in a special workflow activity guide mode, you see the workflow activity guide functionality. If you access the pages using standard PeopleSoft menu navigation, the workflow activity guide functionality is invisible. This means that you can use the same pages in both the standard navigation and workflow activity guides.

Understanding Workflow Activity Guide Mode

The page itself is viewable in workflow activity mode or in regular page mode. For a user to access a workflow activity guide, the link that takes the user there must be specially constructed. So, the last task that you must perform when developing workflow activity guides is setting up that access, either by creating a worklist item or by constructing a custom link.

Understanding Step Status

As you proceed through the steps, the icons and text in the workflow activity guide change to indicate the status of the step. Depending on how the activity is defined, up to four different statuses are possible, each with its own icon.

Status	Link	Comments
Disabled	Inactive	<p>You cannot yet start this step. Before you can start this step, you must complete the previous step.</p> <p>This status is used when you must complete the steps in sequence; it is used for future steps.</p>
Enabled	Active	<p>You have not started the step, but you can start now.</p> <p>You normally see this status when:</p> <ul style="list-style-type: none"> • An activity includes parallel steps, that is, steps that you can complete in any order. • You finish working on one step and haven't started working on another.
In Process	Inactive	You are currently working on this step.

Status	Link	Comments
Worked	Active or inactive	You have completed the step. If you are permitted to work the step multiple times, the link is active; if you are not permitted to work the step multiple times, the link is inactive. You can always return to a worked step using the Back button on the page.

Accessing Workflow Activity Guides Through Worklists

Worklist links are generated when a transaction triggers a workflow event that sends a routing to the worklist. The workflow event is part of a business process and activity that were defined when the workflow application was built.

In worklist links, the &ActName value is the name of the workflow activity where the event is triggered, not the name of the workflow activity guide that works the item. However, when resolving a worklist link (identifiable because the ICType=Worklist), PeopleSoft determines the name of the activity that works the event and, if that event is a workflow activity guide, puts the page in workflow activity guide mode.

Notice that you can direct users to workflow activity guides from their worklists. To do this, build a workflow application with a page on which the user initiates the workflow event. The user then receives a routing, either in a worklist or by email, with a link that takes the user to the workflow activity guide.

For example, you can create a page on which users update marital status. This page isn't part of a workflow activity guide; it's a regular PeopleSoft page accessible through regular portal navigation. Behind the page, you create a workflow application that is worked by the Marriage activity. If the Marriage activity is marked as a workflow activity guide, the workflow link that takes users to this activity enables users to see the page in workflow activity guide mode.

The advantage of using workflow to access workflow activity guides is that the necessary link is automatically created by standard workflow processing. You don't need to create the link manually or understand the syntax of the link.

The disadvantage to using workflow to access workflow activity guides is that, from your users' perspectives, there are two separate transactions involved: the one that triggers the workflow routing and, after the user has received the routing, the one that works the item.

Accessing Workflow Activity Guides Through Custom Links

If you don't want to use a workflow application to provide access to a workflow activity guide, you must provide users with custom navigation that enables them to reach the page in workflow activity guide mode.

The advantage of using custom navigation is that users can complete all of the steps in one session. They don't have to go from the PeopleSoft system to a workflow notification and back to the PeopleSoft system.

The disadvantage of using a custom link is that you can't rely on PeopleSoft to create the link for you; you must understand the proper link syntax and manually code the link in PeopleCode.

The following procedure outlines one approach to creating custom links.

To transfer a user to a workflow activity guide:

1. Set up a component with a single blank page.

This page acts as a transfer point only; users accessing the page are automatically transferred elsewhere without ever seeing the blank page.

2. Add the component to a portal registry.
3. Transfer the user from the blank page to the workflow activity guide.

Designing PeopleSoft Navigator Maps

Understanding PeopleSoft Navigator

PeopleSoft Navigator enables end users to see workflow maps according to their hierarchical relationships. Users can browse the maps and navigate to individual pages by clicking the map elements representing the pages.

Users access PeopleSoft Navigator in PeopleSoft Pure Internet Architecture by selecting Main Menu, Worklist, Workflow Navigator, which causes the Navigator structure to appear in place of the standard PeopleSoft portal structure. In the Navigator structure, users see a tree representing the hierarchical relationships of the workflow maps that fall under the high-level map that is used as the Navigator homepage.

As the user clicks the business processes and activities in the tree, the corresponding maps appear on the right-hand side of the screen. When the user clicks a step—the map element corresponding to a single page—the corresponding page appears on the right-hand side of the screen.

Maps that are used for workflow are visible through PeopleSoft Navigator; you can also create additional maps (which are not part of workflow) specifically for use in Navigator. In this context, the maps are commonly called Navigator maps, rather than workflow maps.

Understanding Navigator Map Design

The mechanics of creating Navigator maps are the same as those for creating all other workflow maps. Of course, you omit workflow-specific elements, such as events and routings, if PeopleSoft Workflow does not also use the map.

However, because Navigator maps serve a different purpose than maps designed for workflow purposes, there are additional design considerations:

- Navigator is organized hierarchically.

Users drill down from business processes to activities (or other business processes), then down to steps. A well-designed hierarchy of business processes and activities is important for usability.

- You need a business process that can serve as the Navigator homepage, the first map that users see.

Users can drill down only to maps that are hierarchically related to this homepage. Therefore, the homepage hierarchy is also important for security.

- Because the maps are visible to end users, good graphic design is important.

For example, icon position within maps and aesthetic elements on maps, while irrelevant to workflow, can help users understand the maps and the processes that they represent.

Establishing Navigator Homepages

This section provides an overview of Navigator homepages.

Understanding Navigator Homepages

A Navigator homepage is the first business process that a user sees after accessing PeopleSoft Navigator. Normally, the homepage is a business process composed of all other business processes that are to be visible in PeopleSoft Navigator. However, if only one business process is to be visible, you can use it as the homepage.

Navigator homepages are associated with individuals through permission lists, which are associated with a user's profile, as defined in PeopleSoft Security.

Establishing a User's Homepage

To establish a user's homepage:

1. Mark a business process as available for use as a homepage.
2. Identify the business process as the homepage that is associated with a permission list.
3. Associate the permission list with the user's profile.

Preparing a Business Process To Be a Navigator Homepage

To prepare a business process to be a Navigator homepage:

1. In PeopleSoft Application Designer, open the business process to use as the homepage.
2. Right-click in the map (but not on an item in the map) and select Definition Properties.

The Business Process Properties dialog box appears.

3. Select the Use tab.
4. Select **Can be used as a Navigator home page**.
5. Click **OK** to close the dialog box.
6. Save the business process.

Associating a Permission List with a Navigator Homepage

To associate a permission list with a Navigator homepage:

1. In PeopleSoft Pure Internet Architecture, select PeopleTools, Security, Permissions and Roles, Permission Lists.
2. Open the permission list to associate with this homepage.
3. On the General page, specify a Navigator homepage.

You can select any business process for which **Can be used as a Navigator home page** is selected.

4. Save the permission list.

Upgrading Maps to Work with PeopleSoft Navigator

If you have maps that were created with versions prior to PeopleTools 8.12, run the following upgrade procedure in PeopleSoft Application Designer.

To upgrade Workflow maps for use in Navigator:

1. Start PeopleSoft Application Designer.
2. Select Tools, Upgrade, Convert Business Process Images.
3. Click **Yes** when prompted to start the conversion process.

The conversion process begins. The Application Designer output window logs the progress of the conversion process, including error messages.

Using Notification Templates

Understanding Notification Templates

Use templates to establish a common format for notifications for a particular purpose. Users can create two types of notification templates:

- Component templates that are used for specific PeopleSoft components.
- Generic templates that can be used from any component.

Template Variables

Defining template variables is the first step in setting up component templates. Template variables are page buffer variables that are always accessible to the component for which the template is being created. Creating component template variables requires an in-depth knowledge of component buffers. Although a component can have multiple templates, only one set of component template variables exists.

Use the Define Template Variables page to define:

- Component data variables that are populated from specific locations on the component buffers.
- Component URL variables that are expanded into URLs in the outgoing notification to help in navigating to the PeopleSoft system.

Component URL variables enable users to navigate to a specific PeopleSoft page when the template containing the variable is activated. You can specify a portal, node, menu, component, market, page, and action for the URL, as well as key values for navigating to a specific target transaction for the selected component. Component URL variables values come from the search record keys in the component and must be resolved to bypass the search page.

By default, when you are creating new template variables, set the first URL variable to the URL for the current component. This assumes that all of the search record fields were found as part of the component buffers. If this is not the case, you must create component data variables and enter the data variable name in the Value column to link the URL variable field name with a data variable.

- External URL variables that are expanded into non-PeopleSoft component URLs, such as an iScript URL or www.yahoo.com.

You can add as many variables as necessary to meet your notification needs.

Note: All variables are resolved at runtime, so you should limit the number of variables to those that you need.

Defining Template Variables

To replicate worklists, use the Template Variables (WL_TEMPLATE_VAR) component.

This section describes how to define template variables.

Defining Template Variables

To access the Define Template Variables page, select PeopleTools, Workflow, Notifications, Component Template Variables, Define Template Variables.

This example illustrates the fields and controls on the Define Template Variables page.

Define Template Variables

Additional Recipient List

Component Name: PC_SR_ENTRY

Market: GBL

Component Data Variables			
Value	Description		
%C1	Business Unit	Edit	-
%C2	EmpID	Edit	-
%C3	Project ID	Edit	-

Add a Component Data Variable

Component URL Variables			
Value	Description		
%URLC1	Status Report Entry	Edit	-

Add a Component URL Variable

External URL Variables			
Value	Description		
		Edit	-

Add an External URL Variable

<i>Field or Control</i>	<i>Description</i>
Add a Component Data Variable	Click to add a component data variable to the template. Click Edit to specify information about the variable.

<i>Field or Control</i>	<i>Description</i>
Add a Component URL Variable	Click to add a component URL variable to the template. Click Edit to specify information about the variable.
Add an External URL Variable	Click to add an external URL variable to the template. Click Edit to specify information about the variable.

Note: Notification template variables do not indicate the true order of the variables. The order of template variables is determined by the sequence of the variables specified in the message text on the Define Template page. If the sequence of the variables in the message text is not in ascending, numerical order, then the template variables that you have declared must follow the order in the message text. If you do not synchronize the order of the template variables and the order that they appear in the message text, the system does not resolve the unordered variables.

Defining Component Data Variables

To access the Component Data Variables page, select PeopleTools, Workflow, Notifications, Component Template Variables, Define Template Variables, Component Data Variables, Edit.

This example illustrates the fields and controls on the Component Data Variables page.

Component Data Variables

Enter information about the field which stores the data value for this variable.

Variable Data Source

Value:	%C1
*Level:	<input type="text" value="Level 0"/>
*Primary Record:	<input type="text" value="PC_SR_SUM_DTL"/>
*Record:	<input type="text" value="PC_SR_SUM_DTL"/>
*Field Name:	<input type="text" value="BUSINESS_UNIT"/>
*Field Label ID:	<input type="text" value="Business Unit"/>
*Display Value:	<input type="text" value="Value"/>

<i>Field or Control</i>	<i>Description</i>
Level	Select the level of the component buffer: <i>Level 0</i> or <i>Level 1</i> .

Field or Control	Description
Primary Record	Specify the record name where the data on the component buffer will be. This name might be the same as the primary record name within a scroll area or a grid.
Record	Specify the record name where the data on the component buffer will be. This name might be the same as the primary record name within a scroll area or a grid.
Field Name	Specify the name of the field where the data on the component buffer will be.
Field Label ID	Select the label that the user who creates the component template sees in the variable list.
Display Value	<p>Select from the Display Values drop-down list box. The most common choice is <i>Value</i>, which is the data value of the field that you selected in Field Name. This is the only valid choice when using Component Templates from the Notify toolbar button.</p> <p>If you are using component templates from custom PeopleCode, you have two additional options:</p> <p><i>Formatted Value:</i> The value that is used is exactly what the user sees on the page, but it is not necessarily the actual value that is stored in the field. For example, if the page field is displaying Xlat values, the template variable is populated with the Xlat value. If the page field shows a formatted date, the template variable is populated with the formatted date. If the page field shows a value from a prompt table, the template variable is populated with the value of the prompt table shown on the page.</p> <p><i>Field Name:</i> The template variable is populated with the long description of the field label that is selected in the Field Label ID field. If no field label exists, it uses the field name in the database table (for example, TRXTYPE).</p>

How Display Values Are Used

The value format for component template variables is %C1, %C2, and so on.

If you specify the Display value as Value, then the variable will resolve to be the value that is stored in the database for that field. In the following screen, note that the value %C5 is assigned a label ID of Transaction Type and the display value is Value (values for this field can be IA, IS, OA, or OS, as defined in the translate table).

This example illustrates a sample display value of Value for the variable data source value %C5.

If the Display Value is set to Formatted Value, then the variable will resolve to be the value that the end user sees on the page for that field.

This example shows the Displayed Text property.

In this example, if the display value selected is *Formatted Value* and the field property displayed text is *Xlat Short*, then %C5 values could be InAsync, Insync and so on (as shown in the following Field Properties example).

This example shows sample translate values.

Field Properties

General |
 International Format Settings |
 Translate Values

Field Name: TRXTYPE

	Value	Active	Eff Dt	Long Name	Short Name
1	IA	<input checked="" type="checkbox"/>	01/01/1900	Inbound Asynchronous	InAsync
2	IS	<input checked="" type="checkbox"/>	01/01/1900	Inbound Synchronous	InSync
3	OA	<input checked="" type="checkbox"/>	01/01/1900	Outbound Asynchronous	OutAsync
4	OS	<input checked="" type="checkbox"/>	01/01/1900	Outbound Synchronous	OutSync

If you set the display value to *Field Name*, then the variable will resolve to be the field label of that field. If no field label exists, then it will resolve to be the field name in the database table (for example, TRXTYPE).

Note: If the component template is activated by a Notify button (not using user-defined PeopleCode), the display values of *Field Name* and *Formatted Value* are not used (the variable will always resolve to the field Value).

Defining Component URL Variables

To access the Component URL Variables page, select PeopleTools, Workflow, Notifications, Component Template Variables, Define Template Variables, Component URL Variables, Edit.

This example illustrates the fields and controls on the Component URL Variables page.

Component URL Variables

Enter information to define a link to a PeopleSoft page.

***Description:**

Use current portal

Yes
 No Portal Name:

Use current node

Yes
 No Node:

***Menu Name:**

***Component Name:** ***Market:**

Use current page

Yes
 No Page Name:

***Action:** Reset Key Values

Component Keys			
Field Name	Value		
BUSINESS_UNIT	<input style="width: 80%;" type="text" value="%C1"/>	+	-
EMPLID	<input style="width: 80%;" type="text" value="%C2"/>	+	-
PROJECT_ID	<input style="width: 80%;" type="text" value="%C3"/>	+	-

The name format for component URL variables is %URLC1, %URLC2, and so on.

Field or Control	Description
Use current portal	If using the current portal for a link, select Yes . If using another portal, select No and enter the portal name.
Use current node	If the current node contains the URL, select Yes . If using another node, activate No and enter the node name.
Use current page	If you want the URL to dynamically include the page that the user has open, select Yes . If you want the URL to include a specific page, select No and enter the page name.

Field or Control	Description
Action	Specify the action for the URL variables: <i>Update/Display</i> , <i>Add</i> , or <i>Correction</i> .
Component Keys	<p>If the component is in the current node, click the Reset Key Values button to populate the Field Name column based on the component metadata.</p> <p>If the component is in another node, set the field names of the component keys yourself.</p> <p>In the Value column, specify a reference to a component data variable that was defined on the Component Data Variables page (for example, %C1, %C2, or %C3).</p> <p>If you do not specify the component key field names and values, the URL displays the Search Dialog page to the user.</p>

Defining External URL Variables

To access the External URL Variables page, select PeopleTools, Workflow, Notifications, Component Template Variables, Define Template Variables, External URL Variables, Edit.

The name format for external URL variables is %URL1, %URL2, and so on.

Specify the complete URL, along with a description.

Defining Additional Recipients

This section provides an overview of the additional recipients list and discusses how to define additional recipients.

Understanding the Additional Recipients List

The additional recipients list contains email addresses or user IDs that the system uses at runtime to send notifications. You set specific fields in a component for this purpose while defining template variables. Whoever defines template variables must know which fields will contain the recipient lists.

Defining the Additional Recipients List

To access the Additional Recipient List page, select PeopleTools, Workflow, Notifications, Component Template Variables, Additional Recipient List.

This example illustrates the fields and controls on the Additional Recipient List page.

After the values are specified on this page, the additional recipient list appears on the Notification page when a notification is sent. Then users can select values from the additional recipient list for the To, CC, or BCC fields.

Field or Control	Description
Level	Select <i>Level 0</i> or <i>Level 1</i> .
Primary Record	For level 1, this is usually the name of the primary record on the grid or scroll area. For level 0, this is the same as the record name.
Record	Specify the name of the record containing the field that stores the list.
Field Name	Specify the name of the field that stores the list.
Field Label ID	Select the label that the user sending the notification sees in the additional recipients list.

Note: Users should enter notification recipient names in the format *Last_Name,First_Name*.

Defining Notification Templates

To define notification templates, use the Notification Template (WL_TEMPLATE) component.

This section discusses how to define notification templates.

Defining Component Notification Templates

To access the Define Template page, select PeopleTools, Workflow, Notifications, Notification Templates

This example illustrates the fields and controls on the Define Template page.

Define Template
Blackberry Email Responses

Component: PC_SR_ENTRY

Market: Global

Template Name: Reminder

***Descr:** **Default Template**

Instructional Text:

Priority:

***Sender:** **Email ID:**

Subject:

Message Text:

You are currently assigned to Project %C3 which requires a status report. Please enter your status report.

Below is the list of available variables for this template.
 You can use template variables within your subject or message text.
 The following variables can also be used:
 %Date, %DateTime, %Time, %ServerTimeZone, %EmailAddress, %NotificationPriority,
 %NotificationToList, %NotificationCCList

Template Variables	Description
%C1	Business Unit
%C2	EmplID
%C3	Project ID
%URLC1	Status Report Entry

After you define template variables, you can create notification templates. You can define more than one template for a component.

<i>Field or Control</i>	<i>Description</i>
Descr (description)	Enter a template description to appear on the Send Notification page if more than one template is defined for the component.
Default Template	Select to identify one template per component as the default template. This is informational only.

Field or Control	Description
Instructional Text	Enter text to appear at the top of the Send Notification page for this template.
Priority	(Optional) Set a default priority for this notification.
Sender	Select: <i>User:</i> Send value to the email address of the user who performs the send. <i>System:</i> Send to the email address of the application server setting SMTPSender. <i>System-Blackberry:</i> Send to the email address of the application server setting SMTPBlackberryReplyTo. <i>Other:</i> Send to the value in the Email ID field.
Email ID	If you selected <i>Other</i> for the sender, enter an email address (for example, CustomerSupport@example.com).
Subject and Message Text	Specify text or any of the available variables (for example, %C1 or %Date) to include in the subject and message.

If BlackBerry responses are entered, the *Sender* field on the Define Templates page is automatically set to System-BlackBerry. This is the only valid value for a BlackBerry template. The *Email ID* field is blank so that the receiver of the BlackBerry notification always replies to a specific email address. The BlackBerry Email Response program polls that one email address.

Defining BlackBerry Email Responses

To access the BlackBerry Email Responses page, select PeopleTools, Workflow, Notifications, Notification Templates, Blackberry Email Responses.

This example illustrates the fields and controls on the BlackBerry Email Responses page.

Field or Control	Description
Response Text	Enter text to add to the template message text. The responses do not appear in the RIM BlackBerry email device until the user selects Reply To. This provides a chance to add a reminder to the message text.
Response Name	Enter up to 10 possible responses. Each of these is associated with the <i>Forward as Email</i> and <i>Forward as Worklist</i> check boxes. Run an Application Engine program section to process the response.
Forward as Email and Forward as Worklist	Select to forward the response email message to the user who sent the notification.
Program and Section	(Optional) Used by the RIM BlackBerry Email Response Program to call specific user sections based on the response detected on incoming RIM BlackBerry email messages. These fields are not required, as users can decide that an email message or worklist entry is enough processing for each RIM BlackBerry response.

Calling Component Templates with PeopleCode

As with generic templates, component templates can be called directly with PeopleCode or with the DoModalComponent as follows:

```
import PT_WF_NOTIFICATION:NotificationTemplate;

&name = "MYCOMPONENTTEMPLATE";

&mynotifytemplate = create NotificationTemplate(%Component, %Market, &name, "C");

&xmlVars = &mynotifytemplate.SetupCompVarsAndRcpts(GetLevel0());

PT_WF_NOTIFY.RAWXML = &xmlVars;

PT_WF_NOTIFY.MENUNAME = %Menu;

PT_WF_NOTIFY.COMPONENT_ID = %Component;

PT_WF_NOTIFY.MARKET = %Market;

PT_WF_NOTIFY.PANELNAME = %Panel;

PT_WF_NOTIFY.WL_TEMPLATE_ID = &name;

PT_WF_NOTIFY.WL_TEMPLATE_TYPE = "C";

PT_WF_NOTIFY.NOTIFY_TO = "targetemail@example.com";

DoModalComponent(MenuName.WORKFLOW_ADMINISTRATOR, BarName.USE, ItemName.NOTIFICATIO→
N, Page.PT_WF_NOTIFY, "U", Record.PT_WF_NOTIFY);
```

Related Links

[Using PeopleCode with Generic Templates](#)

Defining Generic Templates

To define generic templates, use the Generic Templates (WL_TEMPLATE_GEN) component.

This section provides an overview of generic templates.

Understanding Generic Templates

You can call generic templates from any PeopleCode program. Use generic templates when a component template does not meet your requirements. For example, you might use generic templates when developing:

- Application Engine PeopleCode.
- Service Operation handler PeopleCode.
- Notifications being sent in the background in a component, for which the user is not prompted with the Send Notification page.

- Applications that need to have more control of the Send Notification page to set default To, CC, or BCC values, or to set default message text that is editable.
- Applications that need to send HTML email.

Note: The SYSTEMDEFAULT generic template is a special case. It is used by the Notify toolbar button on all components if there are no other component templates defined for that component. You cannot add template variables for SYSTEMDEFAULT. Two template variables are available for this template: %1, which generates a component URL for the page with only search keys from which the **Notify** button is selected; and %2, which generates a component URL for the page with both search keys and alternate search keys. Do not change this template unless you want to make a system-wide change.

Defining Generic Templates

To access the Generic Template Definition page, select PeopleTools, Workflow, Notifications, Generic Notification Templates, Generic Template Definition.

This example illustrates the fields and controls on the Generic Template Definition page.

Generic Template Definition

Blackberry Email Responses

Template: THANKYOU

***Description:**

Instructional Text:

Priority:

***Sender:** **Email ID:**

Subject:

Message Text:

Below is the list of available variables for this template.
You can use template variables within your subject or message text.
The following variables can also be used:
%Date, %DateTime, %Time, %ServerTimeZone, %EmailAddress, %NotificationPriority, %NotificationToList, %NotificationCCList

Template Variables			
*Value	*Description		
<input type="text" value="%1"/>	<input type="text" value="Customer Name"/>	+	-
<input type="text" value="%2"/>	<input type="text" value="Order Number"/>	+	-
<input type="text" value="%3"/>	<input type="text" value="URL to Cust Service Site"/>	+	-

The pages and fields in the Generic Templates component are the same as those for defining the notification templates, except for two key differences:

- A generic template does not reference any information from the template variables component.
Add template variables directly to the generic template explicitly by adding rows in the template variables grid.
- A generic template does not support Additional Recipients.

This statement is true because the generic template is not used to launch the Send Notification page, which is where the additional recipients appear.

To use a generic template from a component, you do not select a **Notify** check box in the component properties dialog box. You must create a button and use PeopleCode to specify which generic template to use. Furthermore, you must pass in data that is needed by the template to populate template variables.

Template variables are placeholders in the template that can be populated with data passed in with PeopleCode. The order of the data being passed must match the order of the corresponding variables in the **Template Variables** grid. Thus, the suggested naming for these variables is %1, %2, and so on. This naming convention is consistent with the Message Catalog use of variables.

Using PeopleCode with Generic Templates

Generic templates other than SYSTEMDEFAULT are usually used only in PeopleCode calls. The following sample code shows how to use a generic template called MYTEMPLATE to send out a notification:

```
import PT_WF_NOTIFICATION:NotificationAddress;
import PT_WF_NOTIFICATION:Notification;
import PT_WF_NOTIFICATION:NotificationTemplate;
Local array of string &aryValues;
Local array of NotificationAddress &mynotifyto;
Local NotificationAddress &mynotifyaddress;
Local Notification &mynotification;
&mynotifyto = CreateArrayRept(&mynotifyaddress, 0);
&emailid = "targetperson@example.com";
&mynotifyaddress = create NotificationAddress("", "", "", &emailid, "Email");
&mynotifyto.Push(&mynotifyaddress);
&mynotifytemplate = create NotificationTemplate("", "", "MYTEMPLATE", "G");
/* Populate an array to contain the values needed by the template */
&aryValues = CreateArrayRept("", 0);
&aryValues.Push("FIRST VALUE");
&aryValues.Push("SECOND VALUE");
&xmlVars = &mynotifytemplate.SetupGenericVars(&aryValues);
&mynotifytemplate.GetAndExpandTemplate(%Language, &xmlVars);
/* At this point, the &mynotifytemplate should have every value resolved */
&mynotification = create Notification("sourceperson@example.com", %Date + %PerfTime⇒
, %Language);
```

Note: To ensure a unique timestamp for each notification that is sent, you must pass a DateTime value that includes milliseconds to the dtmCreated parameter. Because the %Datetime system variable always returns 0 for the milliseconds value, use the combination of %Date+%PerfTime instead.

See “%Date” (PeopleCode Language Reference), “%PerfTime” (PeopleCode Language Reference).

```
&mynotification.NotifyTo = &mynotifyto;
&mynotification.Subject = &mynotifytemplate.Subject;
&mynotification.Message = &mynotifytemplate.Text;
&mynotification.Send();
```

Note: You can also use this code for component templates by replacing the *G* with a *C*. Then, populate the component name and market when calling the template as shown in the following example code. The template variables are all assumed to be in the page buffers.

```
&mynotifytemplate = create NotificationTemplate(%Component, %Market, "MYCOMPONENTTE⇒
MPLATE", "C");

&xmlVars = &mynotifytemplate.SetupCompVarsAndRcpts(GetLevel0());
&mynotifytemplate.GetAndExpandTemplate(%Language, &xmlVars);
```

Deleting Templates

To delete notification templates, use the Delete Notification Templates (WL_TEMPL_DELETE) component.

You can delete component templates, but not generic templates.

To delete a component template:

1. Select PeopleTools, Workflow, Notifications, Delete Notification Templates.

The Delete Notification Templates page displays all of the component templates defined in the system.

2. Select the **Select** check box for templates that you want to delete.
3. Click the **Delete** button.

Note: This procedure does not remove the template variables.

Accessing Notification Templates

To access notification templates and use the Notify feature, select the Notify check box in the Selected Toolbar Actions group box in the Component Properties dialog box for each component. This causes the Notify button to appear on each browser page of the component.

When you click the Notify button, the system saves the component information and displays the Send Notification page. Add notification details on the Send Notification page before you send the notification as an email message or worklist item.

You can also access notification templates through user-defined PeopleCode. At runtime, users can select the type of template (generic or notification [component]), the actual template, and the data that populates the template variables.

Note: Spell check is enabled for notification templates and generic templates to verify message text and response text.

See “Sending and Receiving Ad Hoc Notifications” (Applications User’s Guide).

Sending Email Notifications in a User's Preferred Language

This section provides an overview of sending email notifications in a user's preferred language.

Understanding Sending Email Notifications in a User's Preferred Language

If your organization has PeopleSoft users who speak multiple languages, you can send email notifications in a user’s preferred language. You have these options:

- Sending email notifications using `SetLanguage()`.
- Storing preconfigured email text in the Message Catalog.

When developing custom notifications involving multiple languages, consider the following:

- The PeopleSoft system *does not* translate email text from one language to another.

This discussion assumes that you implement one of the methods described in this section to route emails to users in their preferred language.

- When calling the `SetLanguage()` online, only the language of the sender can be accessed.

The page buffer contains only the language of the user currently accessing the component. If used in an Application Engine program (in batch mode), multiple languages can be accessed.

- The Notification class does *not* support multiple languages for each recipient.

The system sends the email in the language of the sender and not each individual recipient. The page buffer contains only the language of the user currently accessing the component.

- If you do not implement any custom email notifications to deal with multiple languages, the system sends email notifications only in the language last used (the language of the sender).

Related Links

“Understanding Notification Classes” (PeopleCode API Reference)

“Using Administration Utilities” (System and Server Administration)

Sending Email Notifications using `SetLanguage()`

The PeopleSoft system does not translate email content when sending email. However you can use predefined text in the message catalog or Notification templates to accommodate different languages.

Using the `SetLanguage()` PeopleCode function enables the system to read the user profile language preference of the intended recipient and send an email in that user's preferred language.

If there are multiple recipients with different language preferences, then individual emails can be sent to each recipient using a loop around the `SetLanguage()` and `TriggerBusinessEvent()` function calls. The same method can be applied to `SendMail`.

As an example, assuming the **TO** field is a Role mapped to a field **SEND_TO_ROLE** without route control, you can make the following changes:

To send email notifications using `SetLanguage()`:

1. Change the field map for the **TO** field in Activity email routing to *Roleuser by Oprid Qry* or *Roleuser by Roleuser Qry*.
2. Map the bind variable to a field on the page (the value of which will be formatted at runtime in PeopleCode).

For this example, assume the field to be *RECEIVER_ID*. It can be a field of a derived/work record.

3. In the event for which the `TriggerBusinessEvent`, or `SendMail`, is called, use the following code as a model, and modify the emphasized variables:

```
Local Rowset &ROLE_USER;

/* 1. Retrieve the TO user list */
/* Create a rowset to retrieve all users for the role */
&ROLE_USER = CreateRowset(Record.ROLEUSER_VW);
&ROLE_USER.Fill("where ROLENAME= :1", SEND_TO_ROLE);

/* Loop through user list to send email in their language code */
For &i = 1 To &ROLE_USER.ActiveRowCountRECEIVER_ID = &ROLE_USER(&i).ROLEUSER_VW
W.OPRID.Value;

    /* 2. Get the user language code and set the language code*/
    SQLExec("Select LANGUAGE_CD FROM PSOPRDEFN where OPRID = :1", &OPRID, &LAN_CD);
    &temp = SetLanguage(&LAN_CD);
    /* check return code &temp for error .....*/

    /* 3. Retrieve text from message catalog for the language code */
    &subject = MsgGetText(msg_set, msg_num_subject, "");
    &text = MsgGetText(msg_set, msg_num_text, "");
    /*..... Format fields mapped in email route for translation .....*/
    /* RECORD.FIELD_SUBJECT.Value = &subject; */
    /* RECORD.FIELD_TEXT.Value = &text; */

    /* 4. Call TriggerBusinessEvent or SendMail to send email */
    &temp = TriggerBusinessEvent(BusProcess."bus_proc_name",
BusActivity."activity_name", BusEvent."event_name");
    /* &temp = SendMail(0, RECEIVER_ID, "", "", &subject, &text); */

End-For;

/* 5. Set language code back to current user */
SQLExec("Select LANGUAGE_CD FROM PSOPRDEFN where OPRID = :1", %OperatorId, &ORIGINAL_LANGCD);
&temp = SetLanguage(&ORIGINAL_LANGCD);
/*..... Or &temp = SetLanguage(%Language).....*/
%OperatorId, &ORIGINAL_LANGCD);
&temp = SetLanguage(&ORIGINAL_LANGCD);
```

```
/*..... Or &temp = SetLanguage(%Language).....*/
```

Storing Preconfigured Email Text in the Message Catalog

For generic email notifications, such as “An item has been added to your worklist,” you can store copies of the text of this email in the message catalog for as many languages as you support. During the notification, you include PeopleCode to use the appropriate text based on a user’s preferred language.

Note: This method can run online.

Designing BlackBerry Email Responses

Understanding RIM BlackBerry Email Responses

The RIM BlackBerry Email Responses feature enables customers to extend PeopleSoft transactions to a mobile device. By replying to predefined emails, Research In Motion (RIM) BlackBerry wireless handheld users can perform transactions in the PeopleSoft system. For example, they can approve sales quotes, accept field service tickets, and so on.

Before you can use the BlackBerry email response feature in an application, you must:

- Define a notification template to send email messages from a specific component.
- Develop an Application Engine program to handle the responses.

Setting Properties for BlackBerry Email Responses

This section provides an overview of application server Simple Mail Transfer Protocol (SMTP) settings for sending email messages and discusses how to configure the email channel.

Understanding Application Server SMTP Settings for Sending Email Messages

At runtime, the Send Notification feature depends on application server configuration settings for SMTP. These settings can be changed using PSADMIN.

The following settings are used for BlackBerry email response notifications:

Term	Definition
SMTPGuaranteed	<p><i>0</i>: (Default) Indicates that the SMTP call is done synchronously (while the user waits).</p> <p><i>1</i>: Indicates that the SMTP call is done in a service operation handler (service operation = EMAIL_MSG).</p> <p>Enter 1 if you want TriggerBusinessEvent email PeopleCode to be delivered through the messaging system.</p>

Term	Definition
SMTPBlackBerryReplyTo	<p>Use when the sender on the template is set to System (which is always the case for BlackBerry) and BlackBerry email responses are defined for the template (on the Define Template page).</p> <p>Enter the internet address that you want to be the reply-to address for Blackberry email responses. This must be a valid address, such as user1@example.com.</p> <p>The default is null.</p>

Note: The node MCF_GETMAIL is delivered with the PeopleSoft system. Users must configure the user, password, and server for their environments.

The following table describes MCF_GETMAIL routings:

Service Operation Name	Description
MCFEM_MSGCOUNT	Retrieves the number of email messages that are available on a mail server.
MCFEM_READALL	Reads all messages from a mail server.
MCFEM_REQ_DELMSG	Deletes a specific message from a mail server.
MCFEM_REQ_DELATT	Deletes an attachment.
MCFEM_REQ_MKFOLDER	Creates an IMAP folder.
MCFEM_REQ_READHDRATT	Reads headers and attachment information from a mail server.
MCFEM_REQ_READMSGATT	Reads a specific message with attachments from a mail server.

Related Links

“Understanding PSADMIN” (System and Server Administration)

Configuring the Email Channel

Because the email channel uses a PeopleSoft Integration Broker gateway, the email channel requires additional configuration.

See “Configuring Email Channel in PeopleSoft Integration Broker” (MultiChannel Framework).

Creating an Application Engine Program for Responses

This section provides an overview of application engine programs for responses.

Understanding Application Engine Programs for Responses

After you determine the valid responses for a transaction, code a separate Application Engine program section to handle each response. The program sections require that:

- The Application Engine program that contains the called sections are tagged as a library.
Each section must have public access.
- The program includes the WL_RIMRESP_AET and WL_RIMRESP2_AET state records.
- The called section accesses all of the fields from the WL_RIMRESP2_AET state record:
- The called section need not perform database commits.

The calling program does this.

The following fields can be included in Blackberry response state records:

Term	Definition
EMAIL_FROM	The email address of the person replying to the BlackBerry email message.
WL_SUBJECT	The email subject.
WL_RESPONSE	The response from the BlackBerry pager, as it was extracted from the email body.
EMAIL_TEXTLONG	The complete email body.
WL_PROCESS_FLAG	This field marks a BlackBerry transaction as having been worked. If the application requires that multiple BlackBerry responses be processed, the called Application Engine user section must set this field to <i>N</i> before ending. The main Application Engine program then updates the appropriate table.
COMPONENT_ID	The component of the template that was used in the originating email message (if any).
MARKET	The market of the template that was used in the originating email message (if any).
WL_TEMPLATE_ID	The template ID.

Term	Definition
LANGUAGE_CD	The language of the original email message.
NOTIFY_TO	A listing of the user IDs that were used when the original email message was sent.
EMAIL_SENDER2	The value of SMTPBlackBerryReplyTo that was used in the application server configuration file when the initial email message was sent to the pager.

Activating the Send Notification Component

To activate the Send Notification component:

1. Select the component for which you created the template.

You must have previously created a component template and associated it with a component. Navigate to that component page on your browser. You should see a **Notify** button in the lower part of the screen.

2. Click the **Notify** button.

This action saves the transaction and opens the Send Notification component. The text from the template appears on this page and shows that all of the variables have been resolved.

Note: BlackBerry responses do not appear in the template text section.

3. Enter the names or email addresses of the recipients in the **To**, **CC**, or **BCC** fields.
4. Enter the message text in the **Message Text** field.
5. Click the **Send** button.

Additional Notes about Send Notification

Activating the Send Notification component validates recipient names (not email addresses) and then determines whether any BlackBerry email responses must be appended to the message text.

If the template includes BlackBerry email responses, a globally unique identifier (GUID) is generated and linked to the NOTIFY_ID. The GUID is appended to the subject text so that it is available in the reply email message. The system sorts the users by preferred language and sends the notifications by language to the recipients.

The send method in the notification application class determines whether the send is Worklist, Email, or Both (based on the values that the recipient sets in the workflow routing preferences user profile).

All notifications are saved to the database and keyed by NOTIFY_ID and LANG_CD.

Running a BlackBerry Response Application Engine Process

The BlackBerry Response program processes email messages that have been returned from BlackBerry devices. Typically, users set up the BlackBerry Response program to run automatically every few minutes within the process scheduler. The run frequency depends on the individual installation and on the amount of expected traffic of BlackBerry pager email responses.

To perform a BlackBerry response from a run control page:

1. Select PeopleTools, Workflow, Notifications, Process Blackberry Responses.
2. Add a new run control ID.
3. Set the node field name to MCF_GETMAIL.
4. Click the **Run** button.

Possible Errors Encountered

The BlackBerry Response program processes only email messages that contain the GUID in the subject line. All other emails are ignored and will be left in the POP3 server. The presence of the GUID indicates that the email message is a BlackBerry pager response.

If the program encounters unexpected conditions while running, it logs error information for each email message and the error count increments:

- Find the error count in the Message Catalog for each run of the program.
- Find the error details in the BlackBerry error log, accessible from the BlackBerry Error Log component.

This component enables users to identify unprocessed BlackBerry pager response email messages. Search for errors by the run process ID of the BlackBerry Pager Response program. The page shows the error condition that was encountered.

Some errors (error numbers 200–299) cause the program to terminate abnormally. If this happens, restart the program to process email messages that were left unfinished. This table describes the errors:

Error	Description
101	No row was found in table PS_PT_WF_NOTFYGUID. This table should always contain a row for the GUID being processed.
102	The email ID of the response email message was not found as a user ID in table PS_PT_WF_NOTFY_TBL.
103	No email ID was found for the current OPRID.
104	The response returning in the email message was not found in the template.

Error	Description
105	No row was found in PS_PT_WF_NOTFY_TBL for the current GUID.
202	The node name was left blank or was invalid in the run control of the program.
203	The call to Synchronrequest failed. Unable to connect to the POP3 connector or the POP3 server.
204	An email message with a valid GUID did not return from the POP3 connector with a unique identification listing (UIDL). Normally, the POP3 server always returns a UIDL for each email message. If the POP3 server does not offer a UIDL, BlackBerry Pager Response processing cannot function. This is a requirement.
205	Failed to delete the email message from the POP3 server.

Chapter 15

Administering PeopleSoft Workflow

Scheduling Workflow Processes

You can run several types of processes to monitor workflow applications. These processes can perform a variety of monitoring tasks, such as checking worklists for timed-out work items. This PeopleSoft application delivers some workflow processes (discussed in the following section), and you can add your own.

Although the processes that PeopleSoft delivers are already defined in PeopleSoft Process Scheduler, you must submit Process Scheduler requests to specify when, where, and how often to run each process.

You must schedule Application Engine programs that you have built to facilitate batch workflow processing, including both programs that you created and several predefined Application Engine programs that are used to monitor workflow.

When you initiate a workflow, you usually set up these processes to run on a recurring schedule. If you do, you do not need to start the processes every time that you want them to run. You must restart them only if the schedule that you specify expires or to change their schedule.

Setting Workflow Defaults

Before you start routing work items, you should perform some administration tasks. Unlike most administration tasks, you must perform this set of tasks only once (or at least infrequently).

This section provides an overview of workflow defaults and discusses how to set workflow system defaults.

Understanding Workflow Defaults

When you define a role as a query, the system determines who should receive work items at runtime. Possibly, no users meet the criteria for the role. For instance, a query that returns the buyer assigned to work with the vendor of the ordered item might fail to return a user if someone orders an item from a new vendor.

The default user should be someone in your information systems department who is an expert in PeopleSoft Workflow. This administrator is typically responsible for reassigning the work items to another user and for updating the route control information so that future items are routed appropriately.

PeopleSoft Workflow can route work to users through the user's worklist or by email message. You can suspend all routings of a particular type by clearing the appropriate option: **Worklists Active** or **Email Active**. Before PeopleSoft Workflow performs a routing, it checks these settings.

The **Delete Pooled WL When Select** option allows the user to specify when the system should remove pooled worklists from another user's queue. The **Previous User** field reflects only the last user ID assigned to a worklist item. The system updates the value when a user accesses the Worklist and Worklist Detail pages, the Worklist tab for a user profile, or the Worklist Entry Updates page. If you have developed any custom worklist maintenance pages, you must update this field manually.

Setting Workflow System Defaults

To access the Worklist System Defaults page, select PeopleTools, Workflow, Defaults and Messages, Set Workflow System Defaults.

This example illustrates the fields and controls on the Worklist System Defaults page.

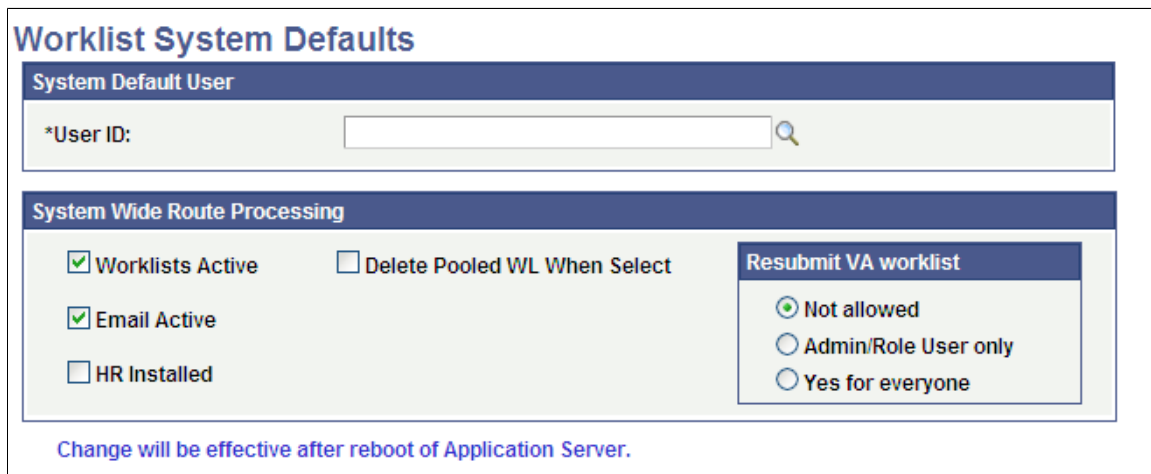

<i>Field or Control</i>	<i>Description</i>
User ID	Select a system default user.
Worklists Active and Email Active	Specify which types of routings are active: <ul style="list-style-type: none"> • Worklists Active: Enables worklists for your users. • Email Active: Enables the system to send email to workflow users. Your application server Simple Mail Transfer Protocol (SMTP) system needs to be configured before sending email notifications.

Field or Control	Description
HR Installed (human resources installed)	<p>Specify whether you are using PeopleSoft HCM applications.</p> <p>The system uses this setting to determine a role user's supervisor:</p> <ul style="list-style-type: none"> • If the check box is cleared, a Supervisory Role User field appears on the user's profile. • The system uses the user ID in this field when it must forward a work item to a user's supervisor. • If the check box is selected, the system determines a user's supervisor as it does throughout PeopleSoft HRMS applications: from the user's PERSONAL_DATA record.
Delete Pooled WL When Select	Select to delete pooled worklists.
Resubmit VA Worklist	The last field for this group box controls how Virtual Approver handles reassigned and resubmitted approval process.

Resubmit VA worklist

To help you understand the options within this group box, the following scenarios are provided, which assume the process is already at manager level.

Scenario	Description
A	A worklist item is reassigned to a user within the supervisor level. The previous behavior of the system is as follows: Upon approval, a message appears stating that the Worklist needs Manager Approval (if a message catalog is used in the Approval Rule Set). At this point, Virtual Approver will send the worklist to the manager again. The worklist will be dropped from the user's list.
B	The worklist item is reassigned to a user with no approval authority. The previous behavior of the system is as follows. Upon approval, the system completely drops the worklist from the user's list with no message shown.
C	The worklist is reassigned to a user within the president level, who can then approve the item.

Note: These three scenarios also apply for a user accessing the approval page directly, in which case the worklist will not be dropped from the list.

Specify how the system should handle reassigned Virtual Approver worklist items.

Field or Control	Description
Not allowed	In scenario A, the system presents an error notifying the user that this approval had been submitted before. The system will not allow the user to resubmit for approval. In scenario B, the system presents an error expressing the fact that the user to which the worklist is being assigned does not have the appropriate approval authority. In both scenario A and B, the transaction cannot be completed and saved.
Admin/Role User only (administrator/role user only)	Only an administrator or the user that has the appropriate role on one of the approval steps can save and resubmit worklists for approval
Yes for everyone	The system does not present error messages. All users can save and resubmit worklists for approval.

Defining Worklist Messages

This section provides an overview of worklist messages and discusses how to send and receive worklist messages.

Understanding Worklist Messages

PeopleSoft Workflow administrators frequently communicate information to system users. For example, an administrator might send everyone the backup schedule or send managers a weekly update about the work that their groups performed. Workflow Administrator provides a page for creating and sending this kind of general message. You can send the message by email or to the users' worklists.

For standard messages that you send out regularly to the same people, Workflow Administrator enables you to define default messages and default routings for those messages so that you need only type them once.

A default message is a saved version of a common message that you can use over and over. When you open the Worklist/Email Message page to send a message, you can select from the list of default messages. Then, you can add to or change the message before sending it.

Default messages are also a good way of defining standard mailing lists. You can define default messages without default text, but they are addressed to a default list of users, such as all managers. When you are ready to send a message to the managers, you select the default message and add the text; thus, you do not have to select the managers individually each time.

Defining a Default Message

To access the Default Message page, select PeopleTools, Workflow, Defaults and Messages, Define Worklist/Email Messages.

This example illustrates the fields and controls on the Default Message page.

To define a default message:

1. Search for an existing message ID or add a new one.

Use the standard search or add method to enter the message ID and access the Default Message page.

Note: Messages are keyed by user ID and message ID.

2. Enter a subject line and message text in the **Subject** and **Message** fields.
You can enter as much or as little of this information as necessary. You can enter the remaining information when you actually send the message.
3. Specify whether to send the message by email or to a worklist.
4. Assign a routing priority to the message.
Select *High*, *Medium*, or *Low*.
5. If you always send this message to the same set of users, select their role user names in the **Default Routing** field.
6. Click the plus button to add additional role users. You can enter as many or as few users as needed. You can change the list when you actually send the message.
7. Save the page.

Sending a Message

To access the Worklist/Email Message page, select PeopleTools, Workflow, Defaults and Messages, Send Worklist/Email Messages.

This example illustrates the fields and controls on the Worklist/Email Message page.

To send a message (either by default or for a particular purpose):

1. If a default message contains the text to deliver to users, select its message ID.

The information from the default message appears on the page. You can add or change this information without affecting the default message.

2. Enter a subject and message text.

The subject that you enter appears as the subject line of an email message or the description of a worklist entry.

3. Select a routing option and priority.
4. Select the role users to whom you want to send the message.
5. Click the plus button to add (or the minus button to remove) role users from the list.

You can enter as many or as few users as needed.

6. To preview a message, click **View HTML**.
7. To send the message, save the page.

Receiving and Responding to Worklist Messages

To receive and respond to worklist messages:

1. In your worklist, select the message to answer.

You can also access the message from the Worklist/Email Reply page.

The Worklist/Email Reply page appears.

2. To reply to the original sender, click the **Reply** button and complete the message on the Reply to Message page.

By using the **Reply** button, rather than the alternate means of navigation, you populate the **Subject** and **Reply To** fields based on the original message. Normally, you accept the default Subject and Reply To values. If they don't appear properly, or if you prefer different values, make the necessary changes.

3. To forward the message to another user, click the **Forward** button and complete the message on the Forward Message page.

By using the **Forward** button, rather than the alternate means of navigation, you populate the **Subject** field based on the original message. Normally you accept the default subject. If it doesn't appear properly, or if you prefer a different subject, make the necessary changes.

4. Click Save to send the message.

Monitoring Worklist Volumes

To set up and run worklist monitors, use the Configure Worklist Monitor (WF_MONITOR_SETUP), Schedule Worklist Monitor (RUN_WL_MONITOR_DBA), and Worklist Monitor Notification (WF_MONITOR_NOTIFY) components.

This section provides an overview of worklist volume monitoring.

Understanding Worklist Volume Monitoring

Workflow Administrator includes an Application Engine program that monitors for overloaded worklists. The program checks for worklists that contain more than a specified number of work items and sends you a warning message when overloaded worklists are found.

To use this program, you define the monitoring parameters. Each set of monitoring parameters is considered a separate worklist volume monitor. You must set up separate worklist volume monitors for different worklists. You can create one or more for each worklist that you want to monitor.

Configuring a Worklist Volume Monitor

To access the worklist volume monitor Setup page, select PeopleTools, Workflow, Monitor Worklists, Configure Worklist Monitor.

This example illustrates the fields and controls on the Setup page.

The screenshot shows the 'Setup' page for a Notification Setup ID of 123. The page is organized into several sections:

- Notification Criteria:**
 - *BP/WL: QE_PROCESS_ORDERS (with a search icon)
 - Supervisor: Supervisor (with a search icon)
 - From Dttm: [Empty field]
 - To Dttm: [Empty field]
 - Status: Available (dropdown menu)
 - Notify Trigger: [Empty field]
 - Total by Individual
- Notification Message:**
 - Set: 107 (with a search icon)
 - Message Text: High Volume Worklist Warning
 - Msg: 9 (with a search icon)
 - Description: Warning! The total number of available worklist entries for worklist %1 for business process %2 has exceeded the acceptable limit. The total number as of %3 is %4 .
 - Notify by Worklist
 - Notify by Email
- User Notification List:** Find | View All | First 1 of 1 | Last
- Worklist User Pool:** Find | View All | First 1 of 1 | Last

To configure a worklist volume monitor:

1. Search for an existing business process name, worklist name, or worklist monitor setup ID, or add a new one.

Use this page to specify which worklist to monitor, how many work items to allow in the worklist, and which message to send when the worklist exceeds the threshold.

2. In the **Notification Message** group box, specify when you want the worklist volume monitor to inform you about the number of worklist entries.

Use the two drop-down list boxes on the first line to identify the worklist that you want to monitor. In the left box, select the business process; in the right box, select the worklist name.

3. Specify a date and time range during which the monitor counts work items.

By default, the worklist volume monitor counts work items added to the worklist starting from today, the day that you define it, through two years from now. To count work items that are already in the worklist, change the value in the **From Dttm** (datetime) field to an earlier date.

4. Specify which work items to count.

The **Status** drop-down list box specifies which work items to count, based on their status. Available values are *Available* (default), *Selected*, *Worked*, and *Cancelled*.

5. In the **Notify Trigger** box, enter the number of work items that constitute the worklist's threshold.

When the worklist contains this number of entries, the worklist volume monitor sends a warning message.

- Specify whether to measure the threshold by an individual user's number of work items or the number of total work items.

If you enter the threshold for each individual user, select **Total by Individual**. If you enter the threshold for the entire worklist, clear the check box.

For example, if a worklist has work items that wait for a manager's approval, you can monitor how many work items are in each manager's worklist or how many are in all managers' worklists.

- In the **Worklist User Pool** box, select the users whose work items you want to include in the count.

When the worklist volume monitor counts work items, it includes only those assigned to a user ID that appears in this box. Click the **Add** button to add as many users as needed.

- Set the notification message.

The **Notification Message** box defines the message that the worklist volume monitor sends when a worklist contains too many work items. The default message is fine for most circumstances, but you can select any message from the PeopleTools Message Catalog. When you select the set and message, the subject and text of the message appear to the right.

Note: The subject of the message is always High Volume Worklist Warning.

- Specify how to deliver the message.

The worklist volume monitor delivers messages to a user's worklist, through email, or both. Select **Notify by Worklist** or **Notify by Email**.

- Specify to whom to send the message.

In the **User Notification List** box, enter the users to whom you want the monitor to send the warning message.

- Save the page.

Scheduling Worklist Volume Monitors to Run

To access the Worklist Volume Monitor page, select PeopleTools, Workflow, Monitor Worklists, Worklist Volume Monitor.

This example illustrates the fields and controls on the Worklist Volume Monitor page.

Worklist Volume Monitor

Run Control ID: 2 [Report Manager](#) [Process Monitor](#)

Reporting Parameters

Workflow Monitor Setup ID: 123 Total by Individual

To schedule worklist volume monitors to run:

1. In the **Workflow Monitor Setup ID** field, select one of the worklist volume monitors that you defined.

When you define a worklist volume monitor, you can specify the volume threshold either as the number of work items that an individual user has or as the number of total work items. The **Total by Individual** check box indicates which option you specified for the selected worklist volume monitor. This information is important on the Process Scheduler Request page.

2. Click the **Run** button.

The Process Scheduler Request page appears.

3. Select a program to run.

The Application Engine program determines whether to monitor by group or by individual, based on whether the **Total by Individual** check box is selected in the worklist volume monitor that you are processing.

4. Complete the Process Scheduler Request page.

Reviewing Notifications Sent by the Volume Monitor

To access the Worklist Monitor Notification page, select PeopleTools, Workflow, Monitor Worklists, Worklist Monitor Notifications.

To review notifications sent by the volume monitor:

1. Search for existing worklist monitor setup ID and datetime created values.

Because one volume monitor can send multiple notifications, you need both values to identify a notification.

2. Review the notification.

Use the standard search method to access the Notify page.

Field or Control	Description
Total Counted	Indicates how many worklist items the worklist volume monitor found. Notifications are sent only when the number of worklist items exceeds the specified threshold.
Subject and Message	Indicate the text of the notification. If the message specified in the Worklist Monitor Setup page included bind variables, the variables are resolved in this message.
Notification Criteria, User Notification List, and Worklist User Pool	Indicate the original worklist monitor setup parameters that triggered this notification.

Checking for Worklist Timeouts

To check for worklist timeouts, use the Timeout Exceptions (WF_RUN_TIMEOUT) and Worklist Timeout Data (WF_TIMEOUT_DATA) components.

This section provides an overview of worklist timeouts.

Understanding Worklist Timeouts

When you define a worklist, you can set a timeout condition, which specifies how long a work item can remain unworked in a worklist before the system forwards it to another worklist. Define this in PeopleSoft Application Designer in the Worklist Attributes dialog box.

The system uses an Application Engine program to check for work items that have timed out and to forward them according to the timeout parameters. You must schedule the Application Engine program to activate this process.

Checking for Worklist Timeouts

To access the Timeout Exceptions page, select PeopleTools, Workflow, Monitor Worklists, Process Timed Out Work Items.

To check for worklist timeouts:

1. Search for an existing run control ID, or add a new one.

Use the standard search or add method to enter a run control ID and access the Timeout Exceptions page. This page displays the run control ID but doesn't contain editable controls.

2. Click the **Run** button.

The Process Scheduler Request page appears.

3. Select the WL_TIMEOUT Application Engine program.
4. Complete the page.

See “Scheduling Process Requests” (Process Scheduler).

Checking Timeout Worklist Data

Timeout parameters include an option to send timeout notifications to the user's timeout worklist.

When users open items in their timeout worklists, they are transferred to the Timeout Worklist Data page for that work item. On this page, the user can view information about the timed-out work item, enter comments about the item, or reassign the item to another user ID.

You can also access this page directly by selecting PeopleTools, Workflow, Monitor Worklists, Review Timed Out Work Items.

Reviewing Work Items Online

To review work items, use the Review Work Items (WF_MONITOR_01), Review Work Items via Context (WF_MONITOR_03), and Update Worklist Entries (WF_MONITOR_UPDATE) components.

This section provides an overview of online work item review and discusses how to search and update work items.

Understanding Online Work Item Review

Worklist Monitor enables you to review the work items in a workflow, regardless of where they are. It provides detailed status information about each item and enables you to update individual work items by:

- Assigning them to different users.
- Changing their status.
- Editing their worklist entries.

Depending on how you want to search for work items, you can access Worklist Monitor based on the:

- Item workflow properties, such as status or the user to whom it's assigned.

You can find items wherever they are in the workflow.

- Fields in the item worklist entry.

You can search for items within a single worklist.

Searching for Work Items Based on Workflow Properties

To access the Review Work Items - Search Criteria page, select PeopleTools, Workflow, Monitor Worklists, Review Work Items by Workflow, Search Criteria.

This example illustrates the fields and controls on the Review Work Items - Search Criteria.

To search for work items based on workflow properties:

1. Select the check boxes for the properties to include in the search, and enter search criteria in the corresponding controls.

To search for all worklist entries, clear all of the check boxes.

<i>Field or Control</i>	<i>Description</i>
Bus Proc / WL (business process and worklist)	Select to search for work items by Business Process Name and Work List Name fields.
WL Datetime Range (worklist datetime range)	Select to search for work items that were created during the time period between the From Datetime and To Datetime values.
User Assigned	Select to search for work items that are assigned to the specified user ID.
Originator	Select to search for work items that entered the workflow because of an action taken by the specified user.
WL Status (worklist status)	Select to search for work items with the specified instance status.
WL Instance ID	Select to search for the work item with the specified ID.

2. Click the **Search** button to perform the search.

When the search is complete, Worklist Monitor displays the total worklist entries that it found, that is, the number of worklist entries that meet your criteria.

3. Move to the Worklist Entries page.

The Worklist Entries page appears, displaying the entries that meet your search criteria. Each line displays information for one worklist entry, including the business process, work list, instance ID, status, and user ID (Oprid).

4. (Optional) Review additional information about an entry.

The buttons at the end of each line provide additional processing.

Field or Control	Description
C (context)	Click to display additional context information about the work item in the WL Context box at the bottom of the page.
T (transfer)	Click to transfer the work item to the page group used to work on the work item. You can work the work item just as if you selected it from its worklist.
U (update)	Click to display the update page so that you can update this work item.

Searching for Work Items Within a Worklist

To access the Review Work Items via Context - Search Criteria page, select PeopleTools, Workflow, Monitor Worklists, Review Work Items by Worklist, Search Criteria.

This example illustrates the fields and controls on the Review Work Items via Context - Search Criteria page.

To search for work items within a worklist:

1. Select the business process and worklist to search.

After you select the worklist, the user-defined fields from the worklist record definition appear in the **Worklist Search Criteria** group box. A **Search Value** drop-down list box is next to each field.

2. Enter search criteria in as many or as few of the fields as needed.
3. Click the **Search** button.

Worklist Monitor displays the total worklist entries that it found; that is, the number of worklist entries that meet your criteria.

4. Move to the Worklist Entries page.

The Worklist Entries page displays the entries that meet your search criteria. See the previous procedure for details about this page.

Updating Work Items

To update work items:

1. Click the **U** button on the Worklist Entries page, or select PeopleTools, Workflow, Monitor Worklists, Update Work Items.

The Update page appears. This page enables you to change the worklist entry for a work item.

2. Update the work item information.

You can change the user to whom the work item is assigned, its status in the worklist, or its description. You can also change the date and time information that the system usually updates, although it's not as common. One reason to change the date and time information is to delay the processing of a work item. To do this, change the available datetime value to a future time.

Note: The Worklist Entry Updates page enables you to reassign individual work items by changing the assigned user. To reassign all items that are assigned to a user, however, this method can be tedious. You can use PeopleTools Security to reassign all work items from one user to another.

See “Specifying Workflow Settings” (Security Administration).

3. Save the page.

Running Workflow Reports

To run workflow reports, use the Worklist Averages (WF_RPT_AVERAGE) and Worklist Totals (WF_RPT_TOTALS) components.

This section provides an overview of workflow reports and discusses how to run workflow reports.

Understanding Workflow Reports

PeopleSoft delivers standard reports that provide status information about the work that your users are accomplishing. The reports fall into two categories:

- Worklist Averages reports, which provide average processing times for completed work items.
- Worklist Totals reports, which count work items by status.

For both types of reports, you can see information about all of your users for all of your business processes, or you can limit the report to specific users or business processes.

The following table describes the available reports and notes the required parameters.

Report	Description	Required Parameters
WFA0001 Workflow - Avg by BP/WL	Reports average processing time for all business processes for a given list of users, grouping them by business process and worklist.	WL User Reporting Pool
WFA0002 Workflow - Avg by BP/WL/ Oper	Reports average processing time for all business processes for all users, grouping them by user , business process, and worklist.	

Report	Description	Required Parameters
WFA0003 Workflow - Avg by Operator	Reports average processing time for all business processes for a given list of users, grouping them by user , business process, and activity.	WL User Reporting Pool
WFA0004 Workflow- Avg by BP/WL All Opr	Reports average processing time for all business processes for all users, grouping them by business process and activity.	
WFA0005 Workflow - Avg for a Single BP	Reports average processing time for the specified business process for a specified list of users.	WL User Reporting Pool, Business Process Name

Running Workflow Reports.

Access the Worklist Averages or Worklist Totals page.

Because the two types of reports have similar reporting parameters, the pages look similar. The pages behave differently, however. Worklist Averages reports the work items completed during the specified time range, and Worklist Totals reports the work items in the worklists by status.

To run workflow reports:

1. Enter the time span for the report to cover.

The two date and time boxes specify the time period for the report. On the Worklist Averages Run page, enter values for the **Worked Datetime From** and **Worked Datetime To** fields. The reports include only work items that are marked as worked during the specified time period. On the Worklist Totals Run page, enter values for the **Available Datetime From** and **Available Datetime To** fields. The reports include only work items that are added to the worklists during the time period.

2. Specify the business process on which to report.

Most of the reports include data about all your business processes, organized by worklist, by user, or both. However, you can report on a single business process. If you want the data for only one business process, select its name from the **Business Process Name** drop-down list box.

3. Specify which users' work items to include in the report.

By default, the reports include work items that are assigned to all users. Limit the report to a specific set of users by selecting their user IDs in the **WL User Reporting Pool** field. If this field does not list users, the report includes all work items. If the field lists users, the reports include only work items that are assigned to those users.

4. Click Run.

The Process Scheduler Request page appears. The list box at the bottom of the page displays the available reports.

5. Select the reports to run.

The reports differ in how they organize the data. Both Worklist Averages and Worklist Totals offer reports organized by:

- Business process and worklist.
 - Business process, worklist, and user.
 - User.
 - Business process and worklist with all users.
 - Information for a single business process only.
6. Complete the Process Scheduler request.

Setting Notification Options

This section provides an overview of setting notification options.

Enabling the Notify Toolbar Button

To enable an end user to send notifications from PeopleSoft components, the Notify toolbar button must be enabled on the Component Properties dialog box.

To enable the Notify toolbar button:

1. Open PeopleSoft Application Designer in PeopleTools.
2. Open the component definition for which you want to enable the **Notify** button.
3. Open the Component Properties dialog box by selecting File, Definition Properties.
4. Select the Internet tab in the Component Properties dialog box.
5. Select Notify in the **Selected Toolbar Actions** group box.
6. Save the component definition.

If Notify is cleared, the Notify toolbar is not visible for that component. If Disable Toolbar is selected in the component properties, the Notify toolbar is not visible for that component.

Setting Workflow Routing Options

After enabling the Notify toolbar button, set the workflow routing options for the role.

If Notify is selected in the component properties and Allow Notifications is selected for the role, the Notify toolbar (the Notify icon at the bottom of the component's browser page) is available in that component for all users in that role.

If Allow Notifications is cleared for the role, the Notify toolbar is not visible for all components for all users in that role.

If Allow Recipient Lookup is selected, all users in the role can search for recipients by prompting against the User Profile table or the Lightweight Directory Access Protocol (LDAP) address book.

Set workflow routing options for each user role.

This example illustrates the fields and controls on the Workflow page.

The screenshot shows the 'Workflow' tab selected in a navigation menu. Below the menu, the 'Role Name' is 'Employee' and the 'Description' is 'Employee'. The 'Workflow Routing Options' section is expanded, showing the following settings:

- Allow notification
- Allow Recipient Lookup
- Use Query to Route Workflow

To set workflow routing options:

1. Select PeopleTools, Security, Permissions and Roles, Roles, Workflow.
2. Select the **Allow Notification** and **Allow Recipient Lookup** check boxes.
3. Save the page.

Setting Delivery Options

At runtime, the Send Notification page references the routing preferences for each recipient to determine the default delivery options. Therefore, the system assumes that:

- Security administrators have set this value for any user on the User Profile page.
- Users have set this value on their My System Profile pages.

Setting Preferences on the User Profile Page

To set preferences on the User Profile page:

1. Select PeopleTools, Security, User Profiles, User Profiles.
2. Enter the user ID.
3. Select the Workflow tab.
4. In the Routing Preferences group box, select Worklist User, Email User, or both.

Note: The **Email User** check box controls email notifications sent using the Send Notifications page. If the check box is not selected, email notifications are not sent to the user through the Send Notifications page. If you are sending email notifications using PeopleCode, this check box has no effect. You must create your own checking logic for sending email notifications.

This example illustrates the routing preferences in User Profile page.

The screenshot displays the 'Workflow' tab of a user profile page. At the top, navigation tabs include 'General', 'ID', 'Roles', 'Workflow', 'Audit', 'Links', and 'User ID Queries'. The user's details are listed as 'User ID: QEDMO' and 'Description: QE User'. Below this, the 'Workflow Attributes' section contains several input fields: 'Alternate User ID', 'From Date', 'To Date', and 'Supervising User ID', each with a search icon. To the right of these fields is a 'Routing Preferences' box with two checked options: 'Worklist User' and 'Email User'. Below the 'Workflow Attributes' is the 'Reassign Work' section, which includes a checkbox for 'Reassign Work To:' followed by a search field. At the bottom, it shows 'Total Pending Worklist Entries: 0'.

Setting Preferences on the My System Profile Page

To set preferences on the My System Profile page:

1. Select PeopleTools, My System Profile.
2. In the **Workflow Attributes** group box, select the **Email User** check box, the **Worklist User** check box, or both.

Based on the routing preferences, Delivery Options are set for each recipient, as shown in the following examples:

When you click the notify button on a page, the send notification page appears.

This example illustrates the fields and controls on the Send Notification page.

Send Notification

Type names or email addresses in the To, CC, or BCC fields, using a semi-colon as a separator.
Click LOOKUP RECIPIENT to search for a name. Click DELIVERY OPTIONS to view or change the method of the send.

Notification Details	
To:	
CC:	
BCC:	
Priority:	▼
Subject:	<Enter Subject here>
Template:	Workflow Notification Priority: %NotificationPriority Date Sent: 2010-06-20
Message:	

[Lookup Recipient](#)
[Delivery Options](#)
 RichText

Click OK to send this notification and exit this page. Click Cancel to exit this page without sending a notification.
Click Apply to send this notification and remain on this page.

OK
Cancel
Apply

Note: Users should enter notification recipient names in the format Last_Name,First_Name.

Use the **Lookup Recipient** link to search for recipients.

This example illustrates the fields and controls on the Lookup Address page.

Send Notification

Lookup Address

Recipient Search

Name:

Search Results

[Customize](#) | [Find](#) | [View All](#) | |

First 1-2 of 2 Last

To	cc	bcc		Recipient	Email Address	User ID
<input type="checkbox"/>	<input type="checkbox"/>	<input type="checkbox"/>		Smith,Cheri	peoplesoft@peoplesoft.com	SSC3
<input type="checkbox"/>	<input type="checkbox"/>	<input type="checkbox"/>		Smith,Cheri	peoplesoft@peoplesoft.com	AMS3

Recipient List

To:

CC:

BCC:

Use the **Delivery Options** link to select the delivery format for each recipient.

This example illustrates the fields and controls on the Delivery Options page.

Send Notification

Delivery Options

Recipient Options

[Customize](#) | [Find](#) | |

First 1-2 of 2 Last

	Recipient	Worklist	Email
	Schumacher,Kenneth/QE_IBSERVICE	<input checked="" type="checkbox"/>	<input checked="" type="checkbox"/>
	Smith,Cheri/AMS3	<input checked="" type="checkbox"/>	<input checked="" type="checkbox"/>

Configuring Worklist Search

Understanding Worklist Search

The PeopleSoft Search Framework enables application developers and implementation teams, to create search artifacts in a consistent, declarative manner and to deploy and maintain search indexes, using one standard interface, regardless of PeopleSoft application.

With Global Search enabled, the Global Search bar displays on the employee homepage. Beside the keyword edit box, the Global Search bar provides a dropdown list for selecting a specific search category against which to run a search. The search category WORKLIST is used to search for keywords within a worklist.

The Worklist Search Config component simplifies the process to create search definitions that can be used to search the application tables for the keyword and get the list of worklist associated with that key word. This component simplifies the query generation and configuration of search related objects. The Worklist Search Config component provides these advantages:

- The query generation process is automated. When the developer selects the worklist name the queries for the application tables associated with the worklist name are generated and the application records are added to the access list.
- It is easier to create the association between query and search definition.
- Simplifies searching the list of application tables to be configured. For example there may be more than one application table associate with the worklist name.
- All the data required to configure the application table as part of the global search is available in one single page.

Creating New Worklist Search Definition

Access the New Worklist SearchDefinition page, by selecting PeopleTools, Workflow, Worklist Search Definitions.

This example illustrates the fields and controls on the New Worklist SearchDefinition page. You can find definitions for the fields and controls later on this page.

The screenshot shows the 'New Worklist SearchDefinition' page with the following sections:

- Query Generation**: A text input field for 'Work List Name' containing 'Deal Review Worklist' and a search icon.
- Search Definition/Category**: A table with columns 'Source Name', 'Search Definition', and 'Search Category'. The row for 'PTWL_DAD_APV_WL_TR' has buttons for 'Search Definition' and 'Search Category'.
- Deploy/Schedule**: A table with columns 'Source Name', 'Undeploy', and 'Schedule'. The row for 'PTWL_DAD_APV_WL_TR' has buttons for 'Undeploy' and 'Schedule'.
- View Scheduled Status**: A button labeled 'Scheduled Status'.

There are 4 steps involved in creating the search definition:

1. Query Generation
2. Search Definition/Category
3. Deploy/Schedule
4. View Scheduled Status.

Generating the Query

When you select a worklist, a search query is automatically generated by the system for each worklist record in the worklist. The query is named `PTWL_<worklist record name>` and `PSWORKLIST`, `PTWL_PORTAL_VW` and the worklist record. The query includes the following:

- All of the fields from the worklist record.
- Last Updated record field. (LASTUPDDTTM)
- Operator ID record field (OPRID)
- Message Node Name (MSGNODENAME)

- URI Text (URI_TEXT)
- Portal Name (PORTAL_NAME).
- Drilling URL.
- Prompt against the *Last Updated* field.
- Criteria for the *Last Updated* field.

The system also adds the application records to the access group WORKLIST_FILTER, which is specific to Worklist Search. This access group is used at runtime.

To view the generated query, click the Search Definition button and then select View.

Defining Search Definition

When you select the Search Definition button, the Search Definition component will be displayed. For Worklist Search, you need to define the following pages:

- General Settings
- Map Search Attributes
- Security
- Advanced

After completing the necessary page, save the search definition.

General Settings

To access the Search Definition-General Settings page, click the Search Definition button on the New WorkList Search Definition page.

This example illustrates the fields and controls on the Search Definition-General page. You can find definitions for the fields and controls later on this page.

Search Definition Component

[General](#) |
 [Map Search Attributes](#) |
 [Attachment Properties](#) |
 [Security](#) |
 [Advanced](#) |
 [Component Mapping](#)

General Settings

Search Definition PTWL_DAD_APV_WL_TR

*Description

Object Owner ID

Source Information

Source Type Query

*Source Name

Search Result Field Mapping

*Last Modified Date Time

*URL Link

Title

Summary

<i>Field or Control</i>	<i>Description</i>
Search Definition	<p>Displays the search definitions name as specified when adding a new value.</p> <hr/> <p>Note: At least one search definition must use the same name as the search category to which it belongs.</p> <hr/>

Field or Control	Description
Description	Provide any additional information to distinguish the search definition.
Source Type	The source type will always be Query and read only.
Source Name	The query that was generated for the worklist.
View	Click to view the underlying query in Query Manager. This helps you to better understand the data being indexed by the search definition. You cannot make changes to the query when accessing it from the PeopleSoft Search Framework. The View button is intended for informational purposes only.
Last Modified Date Time	Select the field specified in the query that determines the underlying record's update date and time. For example, LASTUPDDTTM.
URL Link	Select the query field containing the drilling URL defined for the query.
Title	Define the title of the search result document. This is the bold, first line of the search result. You can add text and bind variables to the title by clicking the *Title button. You cannot add text to the edit box directly.
Summary	Define the summary, or body, of the search result text. This is the text that appears below the title in a search result document. You can add text and bind variables to the summary by clicking the *Summary button. You cannot add text to the edit box directly.

See “Specifying General Settings” (Search Technology).

Map Search Attributes

Select the Map Search Attributes tab.

The Map Search Attributes page displays all of the query fields for the generated query.

This example illustrates the fields and controls on the Search Definition - Map Search Attributes page. You can find definitions for the fields and controls later on this page.

Search Definition Component

General | **Map Search Attributes** | Attachment Properties | Security | Advanced | Component Mapping

Search Attribute Mapping

Search Definition: PTWL_DAD_APV_WL_TR Reload

Description: Deal Review Worklist

Fields Included in the Index Personalize | Find | First 1-16 of 16 Last

Query Name	Query Field Name	Field to Index	Attribute Name	Attribute Display Name	Is Faceted
1 PTWL_DAD_APV_WL_TR	B.BUSPROCNAME	<input checked="" type="checkbox"/>	BUSPROCNAME	Business Process Name <input type="text"/>	<input checked="" type="checkbox"/>
2 PTWL_DAD_APV_WL_TR	B.ACTIVITYNAME	<input checked="" type="checkbox"/>	ACTIVITYNAME	Activity Name <input type="text"/>	<input checked="" type="checkbox"/>
3 PTWL_DAD_APV_WL_TR	B.EVENTNAME	<input checked="" type="checkbox"/>	EVENTNAME	Event Name <input type="text"/>	<input checked="" type="checkbox"/>
4 PTWL_DAD_APV_WL_TR	B.WORKLISTNAME	<input checked="" type="checkbox"/>	WORKLISTNAME	Work List Name <input type="text"/>	<input checked="" type="checkbox"/>
5 PTWL_DAD_APV_WL_TR	B.INSTANCEID	<input checked="" type="checkbox"/>	INSTANCEID	Instance ID <input type="text"/>	<input type="checkbox"/>
6 PTWL_DAD_APV_WL_TR	B.TRANSACTIONID	<input checked="" type="checkbox"/>	TRANSACTIONID	Transaction ID <input type="text"/>	<input type="checkbox"/>
7 PTWL_DAD_APV_WL_TR	B.BUSINESS_UNIT	<input checked="" type="checkbox"/>	BUSINESS_UNIT	Business Unit <input type="text"/>	<input checked="" type="checkbox"/>
8 PTWL_DAD_APV_WL_TR	B.TREAS_HEADER_ID	<input checked="" type="checkbox"/>	TREAS_HEADER_ID	Deal ID <input type="text"/>	<input checked="" type="checkbox"/>
9 PTWL_DAD_APV_WL_TR	B.INSTRUMENT_TYPE	<input checked="" type="checkbox"/>	INSTRUMENT_TYPE	Instrument Type <input type="text"/>	<input checked="" type="checkbox"/>
10 PTWL_DAD_APV_WL_TR	B.DTTM_STAMP	<input checked="" type="checkbox"/>	DTTM_STAMP	Date/Time Stamp <input type="text"/>	<input type="checkbox"/>
11 PTWL_DAD_APV_WL_TR	A.LASTUPDDTTM	<input checked="" type="checkbox"/>	LASTUPDDTTM	Last Update Date/Time <input type="text"/>	<input type="checkbox"/>
12 PTWL_DAD_APV_WL_TR	A.OPRID	<input type="checkbox"/>			<input type="checkbox"/>
13 PTWL_DAD_APV_WL_TR	C.MSGNODENAME	<input type="checkbox"/>			<input type="checkbox"/>
14 PTWL_DAD_APV_WL_TR	C.URI_TEXT	<input type="checkbox"/>			<input type="checkbox"/>
15 PTWL_DAD_APV_WL_TR	C.PORTAL_NAME	<input type="checkbox"/>			<input type="checkbox"/>
16 PTWL_DAD_APV_WL_TR	Drilling URL	<input type="checkbox"/>			<input type="checkbox"/>

Field or Control	Description
<p>Field to Index</p>	<p>Select the fields that you want to be indexed by the search engine. These fields would be those that you intend the end users would include in search queries intuitively. Fields that you do not select are not indexed. The remaining columns in the grid become enabled only after selecting the Field to Index check box for a particular row.</p> <p>When selecting fields also consider fields that may help to group results or help distinguish security access.</p> <p>Consider the following when you select fields for indexing:</p> <ul style="list-style-type: none"> • Number fields which are marked for indexing can be searched using the advanced search available on a component search, but cannot be searched using the global search. • For date and number fields that have multiple values, the condition between the values in the same document is always an OR condition. For example, if ST_DT>2010/01/01 and ST_DT<2000/01/01 and if ST_DT is a field with multiple values, then the effective condition will be ST_DT>2010/01/01 or ST_DT<2000/01/01, that is, documents which meet any of the conditions will be returned. <hr/> <p>Note: This does not impact single value fields.</p>
<p>Attribute Name</p>	<p>Displays the pre-defined attribute name that identifies the query field in the search engine.</p> <hr/> <p>Note: The attribute name must be unique in a search definition.</p> <hr/> <p>An Attribute Name is formed by concatenating the field name with its field label, unless the label is the default. If the field label is the default, just the field name is used for the attribute name. For example, if the field is VENDOR and the Display Name chosen is the default, then the attribute name is VENDOR. If the Display Name chosen is SUPP1 and it is not the default, then the attribute name is VENDOR_SUPP1.</p> <p>Due to this, there might be conflict between two fields which end up having same attribute name, and in these cases it is recommended to create a new label to make the attribute unique.</p>

Field or Control	Description
Attribute Display Name	<p>Determines how the attribute will display to the end user in the search results and in OpenSearch Dashboards. OpenSearch Dashboards uses the attribute display name as an alias when displaying the fields of a search definition for a visualization. Therefore, the attribute display name must be unique in a search definition.</p> <hr/> <p>Note: The display name comes from the field labels associated with the Query Field Name. It cannot be entered manually. If the wording of the display name is not appropriate, you need to add a new field label. If you select a field that is not the default field label, the Attribute Name will change to reflect your choice. If you change the field labels for existing search definitions, you must perform an update operation for the search definition on the Deploy Search Definition page.</p> <hr/> <p>Note: When creating search definitions be careful not to use the same Attribute Display Names that are used by search record key, alt keys, and list box items, unless their attribute name also matches the search record field name. Using the same display names affects how (if) fields appear to the end user on the Advanced search page.</p> <hr/>

Field or Control	Description
Is Faceted	<p>Select to make this field a facet field, meaning that this field can be used to categorize and narrow down search results based on its value.</p> <p>Defining a field as a facet requires some consideration. Facets cannot be blank, so if a field is not required, then the query needs to be structured so that there are not any blank values. You can use defaults on the record, or build COALESCE statements on a view to populate a field with a default (such as ‘None’, “NA” or “Blank”) if it contains a blank value.</p> <p>If a facet does not have a value, then the query is dynamically modified to return <i>No Value</i> as the title of the facet. This processing is performed only on character attributes; not on long and XLAT attributes.</p> <hr/> <p>Note: Facets based on XLAT fields should be changed to use XLAT Long/Short in the query.</p> <hr/> <p>Note: There is a data size limit of 2000 characters for faceted fields. The system truncates anything beyond 2000 characters.</p> <hr/> <p>Important! Values with data types of datetime cannot be used as facets.</p> <hr/>

See “Mapping Search Attributes” (Search Technology).

Security

Select the Security tab.

This example illustrates the fields and controls on the Search Definition - Security page. You can find definitions for the fields and controls later on this page.

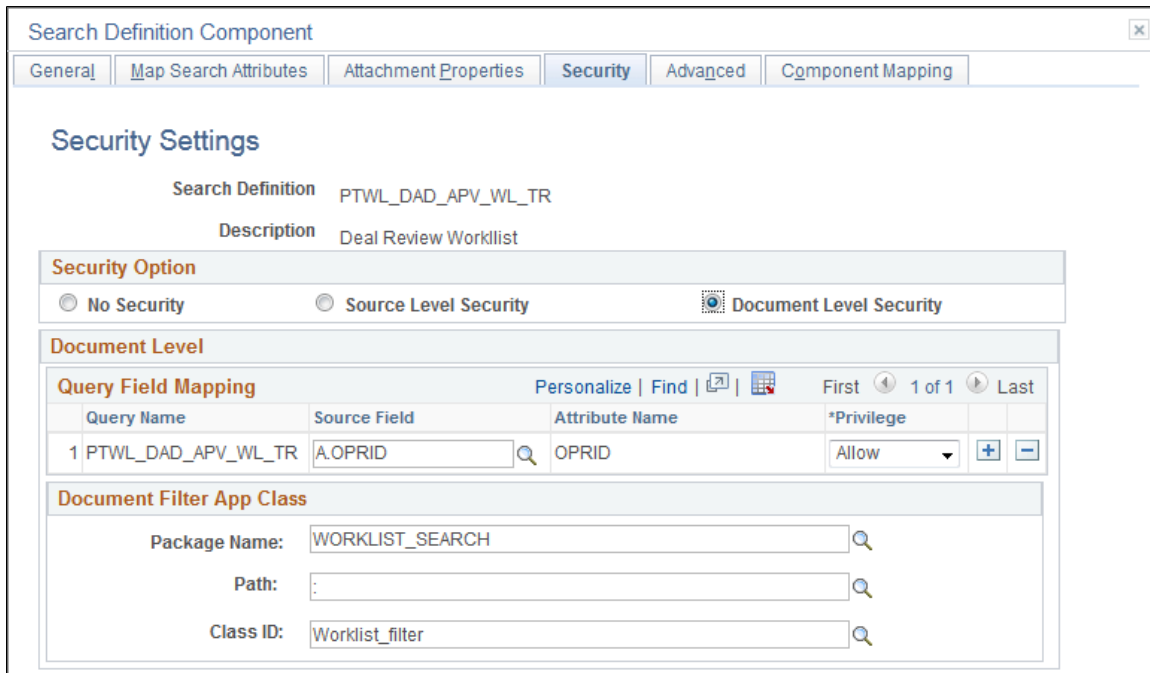

Field or Control	Description
Security Option	Worklist Search uses Document Level Security . Document level security restricts access to specific search results based on users access. For worklists, the user will only see the search results for worklists that meet the search criteria and have been assigned to their user ID.
Source Field	For Worklist Search, the source field will always be OPRID.
Document Filter App Class	For worklist search you will always use: Package Name – WORKLIST_SEARCH Path – : Class ID – Worklist_filter

For additional information on Search Security Setting see “Managing Search Definition Security” (Search Technology).

Advanced

Select the Advanced tab.

This example illustrates the fields and controls on the Search Definition - Advanced page. You can find definitions for the fields and controls later on this page.

X
Search Definition Component

General
Map Search Attributes
Attachment Properties
Security
Advanced
Component Mapping

Advanced Properties

Search Definition PTWL_DAD_APV_WL_TR

Description Deal Review Worklist

Define Query to Delete SBO

Query Name 🔍

URL Link Field 🔍

Pre Processing AE Library

AE Library 🔍

AE Section 🔍

Post Processing AE Library

AE Library 🔍

AE Section 🔍

Encode Search Attributes

	Search Attribute	Attribute Display Name		
1	<input type="text"/>	<input type="text"/>	+	-

Full Indexing Criteria

Index Only Last Days Index Start Date 01/01/1900

Alternate search keywords

Field or Control	Description
Query Name	The query WORKLIST_DELETE_QUERY is used to delete worklist entries from the already indexed documents from the search framework when the worklist item is Marked Worked.
URL Link Field	This is the drilling URL field for the query, for WORKLIST_DELETE_QUERY it is EXPR17_17.

For additional information on Advanced Settings see “Working With Advanced Settings” (Search Technology).

Defining Search Category

To access the Search Category component, click the Search Category button on the New WorkList Search Definition page. This button will become enabled after the search definition is defined.

For Worklist Search, you need to define the following pages:

- General Settings
- Advanced Search Fields
- Facets

After completing these pages, save the search category definition.

General Settings

To access the Search Definition-General Settings page, click the Search Category button on the New WorkList Search Definition page. This button will become enabled after the search definition is defined.

This example illustrates the fields and controls on the Search Category - General Settings. You can find definitions for the fields and controls later on this page.

Search Category

General
Advanced Search Fields
Facets
Custom Search Page
Display Fields

General Settings

Search Category Name PTWL_DAD_APV_WL_TR

*Description Deal Review Worklist

Duplicates Use API Search Group

Object Owner ID

Personalize | Find | |
First 1 of 1 Last

*Search Definition	Description		
PTWL_DAD_APV_WL_	Deal Review Worklist	+	-

Field or Control	Description
Search Category Name	<p>Displays the search category name.</p> <hr/> <p>Important! Though any number of search definitions can be mapped to a search category, for each and every search definition, a search category of the <i>same</i> name must exist, and the search definition must belong to that search category. You can create search categories of a different name that are not associated with a single search definition. A search definition may belong to more than one search category, but it <i>must</i> belong to one with the same name.</p> <hr/>
Description	<p>By default the worklist name is used in the description.</p> <hr/> <p>Note: If this search category becomes exposed through Global Search, then the description you enter may appear in the Global Search Bar. The description must be appropriate for end user viewing. Make the description as informative, concise, and intuitive as possible.</p> <hr/> <p>Note: The description is translatable.</p> <hr/>
Duplicates	<p>For worklist searches the default is <i>Use API</i>.</p> <p>The handling of duplicates will be set in the search request object based on the value set by the application, honoring any values produced by the application PeopleCode.</p>
Search Group	<p>Select to enable this search category to be available for context searching within Global Search.</p>
Search Definition	<p>Add all search definitions that belong to this search category.</p>

Advanced Search Fields

Select the Advanced Search Field tab.

This example illustrates the fields and controls on the Search Category - Advanced Search Fields page. You can find definitions for the fields and controls later on this page.

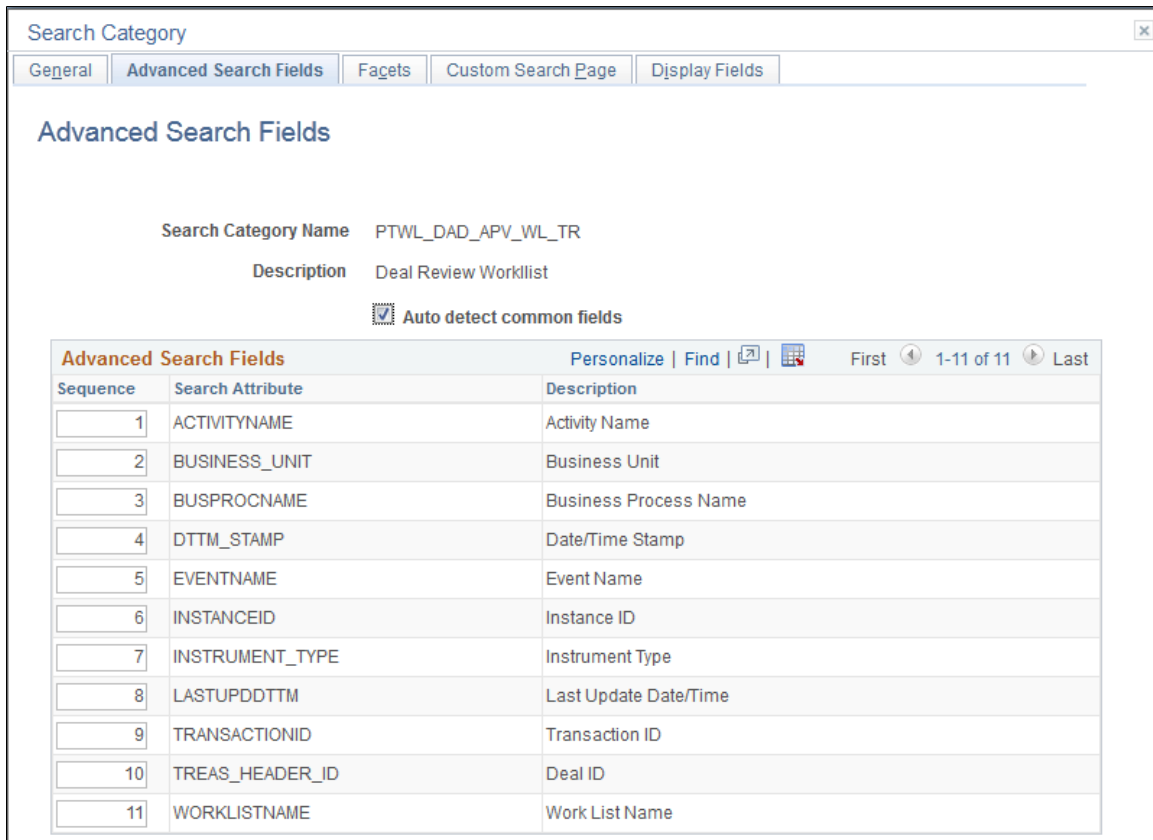

Field or Control	Description
Auto detect common fields	<p>When selected, this flag will gather all fields which are common to all search definitions listed on the General page. This will allow for searching across all search definitions in the category.</p> <p>Select to avoid manually listing the common fields from the joined records. (default)</p> <p>Deselect to delete some or to add additional attributes which are not common to all search definitions.</p> <hr/> <p>Note: When you select the Auto Detect flag, you must save the search category before the common fields will be properly displayed in the grid.</p>
Sequence	Control the sequence in which the search attributes appear in the advanced search interface.

Facets

Select the Facets tab.

This example illustrates the fields and controls on the Search Category - Facets page. You can find definitions for the fields and controls later on this page.

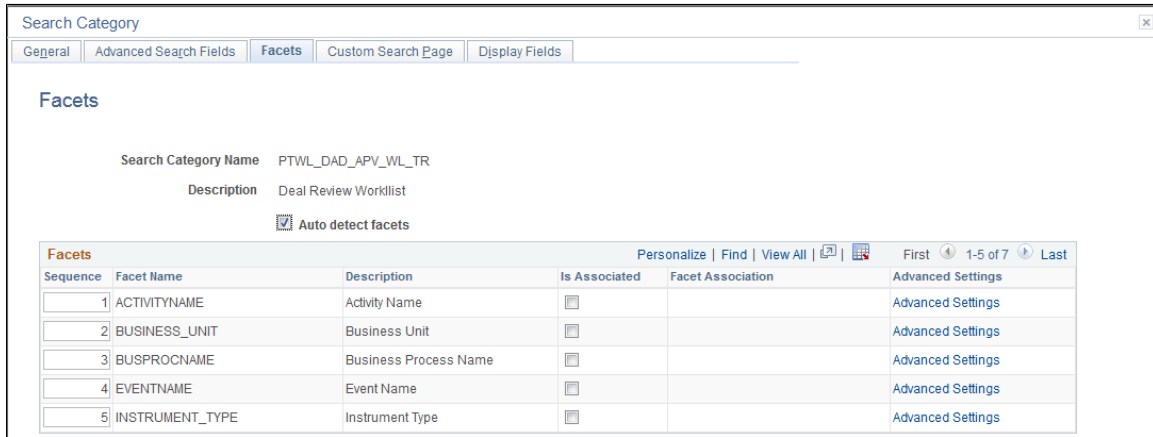

Field or Control	Description
Auto detect facets	<p>Select to detect common facets for all the search definitions belonging to the search category. When you save the search category, any facets that are common to all search definitions are displayed. This saves you from needing to discover which facets can be used to filter across all search definitions.</p> <p>Deselect this option if you wish to remove some facets or add ones that are not common to all search definitions (not recommended as this may distort facet counts).</p>
Sequence	<p>Control the sequence in which the faceted fields display for narrowing search results in an intuitive fashion for users.</p> <p>For example, perhaps you might want to ensure that these faceted fields display in this order: Country, State, County, City.</p>

See “Selecting Facet Settings” (Search Technology).

Deploying and Scheduling Worklist Search Index

Before end users can run searches against the search indexes, the search definitions need to be deployed to the search engine so that search engine can create the structure of the search index based on the search definition, crawl the defined search criteria, and populate the index with the results of the search definition query. When your search definitions are deployed, they become a source that you can view under the Sources tab in the administrative interface.

Deploying Search Definition

To deploy the search definition, select the Deploy button next to the source name on the New Worklist Search Definition page. The Deploy button is enabled once the search definition and search category have been saved.

This example illustrates the fields and controls on the Deploy Search Definition page. You can find definitions for the fields and controls later on this page.

Field or Control	Description
Search Category Name	The search category is defaulted from the New Worklist Search Definition page.
Filter by name	Use to enter full or partial definition names to reduce the list of search definitions appearing in the grid. Note: The values are case-sensitive.

Field or Control	Description
Deploy Search Definition (grid)	<p>Displays all existing search definitions defined in the Search Framework. Columns in the grid are:</p> <ul style="list-style-type: none"> • Definition. Displays the name of the search definitions you've created. Deployable search definitions are having a data source created in Query or Connected Query, as well as being defined in the Search Framework Designer interface. • Description. Displays your search definition description. • Deploy Status. Displays the state of search definition deployment: A search Definition is either Deployed or Undeployed. • Crawl Status. Displays the status of the index build process for a search definition (Success, Fail, Not Crawled). • Run Date\Time. Displays the date and time of the most recent index build process run. • User\Run Control ID. Displays the user ID and the run control ID used to run the index build process. • Update Status. After running the Report Sync Issues audit, the results appear in this column indicating any required updates. • Audit Status. After clicking Audit for a selected search definition, the Audit Status column appears displaying the result (<i>Success, Fail</i>). • Audit Report. If the Audit Status is <i>Fail</i>, the Audit Report column appears providing a link to the audit report for review.
Select All	<p>Click to select all the rows within the grid.</p> <hr/> <p>Note: If all rows in the grid have been selected, the button title changes to Deselect All.</p> <hr/>

Field or Control	Description
Report Sync Issues	<p>Runs an audit checking routine which reports where properties for a search definition differ between PeopleSoft and the search engine. If you have updated a deployed search definition it will no longer be synchronized with the representation on search engine. Results of this check appear in the Update Status column (which, in the case of differences between the corresponding definitions becomes the View Report column). This applies only to deployed definitions.</p>
Audit	<p>Click to run a series of audits on the selected search definitions to ensure they have all requirements in place.</p> <p>After running the audit process, these additional columns appear in the Deploy Search Definition grid: Audit Status and Audit Report. The Audit Status column will indicate <i>Success</i> or <i>Fail</i>. If the result is <i>Fail</i>, then the Audit Report column appears, displaying an Audit Report link, which you can click to review the audit results and correct the reported issues.</p> <p>See the section below: “Running the Search Definition Audit Process.”</p>
Deploy	<p>Deploy the PeopleSoft search definitions selected to the search engine, where it becomes a searchable data source.</p> <hr/> <p>Note: You can deploy multiple search definitions at a time by selecting the corresponding check box in the first column of the grid and then choosing Deploy.</p> <hr/> <p>Note: When you deploy a search definition, the search category of the same name is automatically deployed.</p> <hr/>

Field or Control	Description
Undeploy	<p>Click to remove the representation of the selected search definitions from the search engine .</p> <hr/> <p>Note: You can undeploy multiple search definitions at a time by selecting the corresponding check box in the first column of the grid and then choosing undeploy.</p> <hr/> <p>Note: When you undeploy a search definition, the search category of the same name is automatically undeployed.</p> <hr/> <p>Note: For large indexes, it is recommended to undeploy them during the non-peak hours for performance reasons. While the status displays undeployed, the actual deletion occurs on the search engine asynchronously, and undeploying a larger index requires additional time on it.</p> <hr/>
Update	<p>Click to update the representation of the search definition on the search engine. If you have modified a deployed search definition, the PeopleSoft version and the version on search engine will no longer match. Definitions that need to be updated will appear in the synchronization report. Clicking Update synchronizes the search engine representation of the definition to match the PeopleSoft version.</p>
Delete	<p>Deletes the search definition from the Search Framework. This removes the search definition from the search definition list and from the search categories to which it is mapped. The underlying query and connected query are unaffected.</p>

Scheduling Search Definition

Before end users can submit search requests against the Search Framework deployed objects, the search indexes must first be built on the search engine. Prior to the index being built, a deployed search definition is an empty shell, containing no searchable data. A search index needs to be built for each individual search definition.

An Application Engine program, PTSF_GENFEED, builds the search index and makes it available for search engine.

Creating a search index with the Search Framework involves the following technologies:

- Search Framework
- Application Engine
- Process Scheduler

- Feeds Framework
- Integration Broker

To access the Schedule Search Feed Generation page, click Schedule from the To schedule the Build Search Index, select your options and click Run.

1. Click the Schedule button on the Worklist Search Definitions page.
2. Select your options
3. Click Run.
4. Set process Schedule Request options.
5. Click OK.
6. You will be returned to the New Worklist Search Definition page.
7. Click the Scheduled Status button to view the status of the Process Scheduler job.

This example illustrates the fields and controls on the Schedule SearchFeed Generation page. You can find definitions for the fields and controls later on this page.

The screenshot shows a web form titled "Schedule SearchFeed Generation" with a close button (X) in the top right corner. Below the title is the section "Build Search Index".

At the top of the form, there are labels for "Run Control ID:" followed by the text "PTWL_DAD_APV_WL_TR", "Report Manager", and "Process Monitor". To the right of these labels is a "Run" button with a dotted border.

Below this is a text input field labeled "*Search Definition" containing the text "PTWL_DAD_APV_WL_TR".

There are two main configuration sections:

- Indexing type:** A section with two radio button options: "Full index" (which is selected) and "Incremental Index".
- Language Option:** A section with two radio button options: "Base Language" (which is selected) and "All Languages".

At the bottom, there is a section titled "Full Indexing Criteria" containing two fields: "Index Only Last" with a value of "0" and "Days", and "Index Start Date" with a value of "01/01/1900".

Field or Control	Description
Indexing Type	<p>Select one of the following:</p> <ul style="list-style-type: none"> • Full index. Crawls all transactional data specified by the query criteria and rebuilds the entire index. This option requires the most time. This option must be selected the first time an index is built. • Incremental index. Updates the existing index and adds only documents associated with rows that have been added or updated since the last index build or update. The system determines the required updates based on a comparison between the timestamp of the index and the “last updated” field for the data row.
Language Options	<p>Select one of the following:</p> <ul style="list-style-type: none"> • All Languages. Builds an index for each language enabled on the database. • Base Language. Builds an index only for the base language defined for the database. <p>Your selection depends on the languages enabled for your database and the languages through which you anticipate end users using to perform searches.</p>

Viewing Worklist Search Definition

Use the View Worklist Search Definition page to view all worklist search definitions and the current state.

1. Select PeopleTools, Workflow, Worklist Search Definitions.
2. Select the View Worklist SearchDefintion tab.
3. Click Load to view all of the worklist searches.

This example illustrates the fields and controls on the View Worklist Search Definition page. You can find definitions for the fields and controls later on this page.

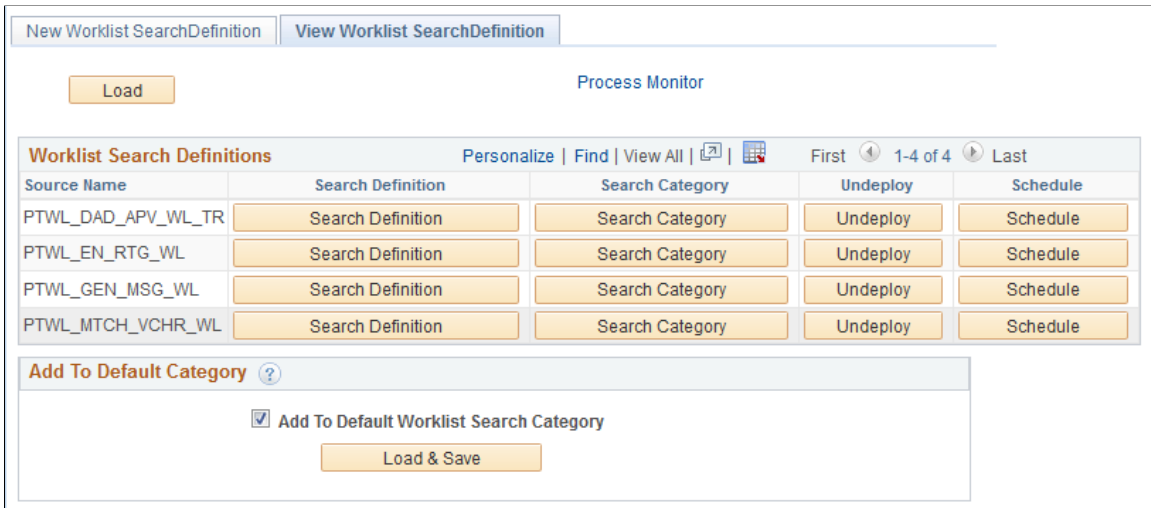

Field or Control	Description
Search Definition	Select this button to open the search definition. The search definition needs to be deployed before you can view or modify the search definition.
Search Category	Select this button to open the search category definition.
Deploy or Undeploy	Depending on the current status of the search definition, the button will either be Deploy or Undeploy. Select this button to take the appropriate action.
Schedule	Select this button to schedule open the Build Search Index page.
Add to Default Worklist Category	Select this checkbox to add all worklist related search definitions to default Worklist search category. Note: The worklist search definitions are added when you click Load & Save.
Load & Save	Select to save the worklist search category.

Migrating Workflow Data

Migrating Workflow Data

PeopleSoft provides Application Data Set (ADS) definitions to migrate workflow data from one environment to another as a project file.

For information on using Data Set Designer and other functionality of data sets, see Lifecycle Management Guide.

ADS Tables for Workflow Data Migration

The following ADS definition tables can be used for migrating workflow data.

ADS Definition	Description
WL_GENERIC_TEMPLATES_DEFN	Table for workflow generic templates.
WL_NOTIFICATION_TEMPLATES_DEFN	Table for workflow notification templates.
WL_TEMPLATE_VAR_DEFN	Table for workflow template variables. This table contains the template variable, which can be used to assign the values to the plug-in properties.

Understanding Worklist Entries Created by an External System

Understanding Worklist Entries from External Systems

The PeopleSoft PT_WORKLIST web service enables third-party systems to create and monitor PeopleSoft worklist entries using web services. This web service provides the capability for the Workflow application to receive a worklist entry from an external system for a task that is to be completed by a PeopleSoft Enterprise application. When the worklist entry is marked complete, the Workflow application returns a reply message to the external system.

The following scenario provides an overview for PeopleSoft Enterprise receiving an external worklist entry and sending a reply message to the originating third-party system when the worklist entry is marked Worked:

1. A third-party system creates a worklist entry for a task that is internal to a PeopleSoft Enterprise application and invokes the PT_WORKLIST web service.
2. PeopleSoft Integration Broker receives the web service request, returns an HTTP acknowledgement to the third-party system indicating receipt of the request, and sends the web service request to the Workflow application.
3. The Workflow application receives the worklist entry request and generates the worklist item on the assigned user's worklist.
4. The assigned user completes the task, and the worklist entry is marked as Worked.
5. When the worklist entry is marked Worked, the Workflow application sends a reply message through the PeopleSoft Integration Broker to the originating system.
6. PeopleSoft Integration Broker receives the web service reply, sends the reply to the third-party system that originated the worklist entry request, and tracks that the third-party system acknowledged receipt of the web service reply.

The PT_WORKLIST web service also provides the capability for the third-party system to track the status of the worklist entry before and after the entry is marked Worked.

Creating Worklist Entries by an External System

A third-party system uses the PT_WORKLIST web service, which is provided by PeopleSoft, to create a new worklist entry for a task that is to be completed by a PeopleSoft Enterprise application. Like any other web service, the worklist web service is discoverable using web service inspection language (WSIL) or in the web services repository or in an optional UDDI registry. The PeopleSoft PT_WORKLIST web service provides two service operations— CREATE_WORKLIST_ITEM and GETWLINSTANCE. A

service operation is a predefined transaction between two or more systems. Both of these web service operations provide a request message for the third-party system developer to enter data and a reply message from PeopleSoft Enterprise. When creating the request message, consumers of this web service (the third-party system) must know the appropriate PeopleSoft Enterprise values to enter for these request message items:

- PeopleSoft business process name.
- Activity name.
- Event name.
- Worklist name.
- PeopleSoft user ID.

The `CREATE_WORKLIST_ITEM` web service operation is the primary service operation for creating worklist entries. `GETWLINSTANCE` is an optional web service operation that enables the third-party system to request status information about the worklist entry. The third-party system web developer must provide the same information for the request message for this optional service operation as was provided for the request message when the `CREATE_WORKLIST_ITEM` web service is created.

The following sections discuss:

- Defining `CREATE_WORKLIST_ITEM` service operation.
- Describing `PT_WL_CREATE_REQUEST` message.
- Describing `PT_WL_CREATE_RESPONSE` message.
- Describing `GETWLINSTANCE` service operation.
- Describing `PT_WL_GET_INSTANCE_REQ` message.
- Describing `PT_WL_GET_INSTANCE_RESP` message.
- Submitting web service operation.

Defining `CREATE_WORKLIST_ITEM` service operation

The third-party system uses this web service operation to enter a request message to create the worklist entry for a PeopleSoft Enterprise application user and to receive notification when the task is marked as Worked. Because several days may elapse from when the request was submitted to when the task is actually completed and marked Worked, this is an asynchronous request-reply web service operation.

Describing `PT_WL_CREATE_REQUEST` Message

The alias for this request message is `CreateWorklistEntryData`. The following table provides information about the fields in this request message:

Schema Input Field Name	PeopleSoft Record Field Name	Description	Type	Required
RequestMessageID	PT_REQUEST_MSG_ID	A message identifier that is defined by the third-party system web service developer. If this field is defined, the third-party system can use the GETWLINSTANCE service operation to request and receive status information about the worklist entry before and after it is marked Worked. If this field is not defined by the third-party system web service developer, status information cannot be provided to the third-party system. If the third-party system developer omits this field, the Transaction ID of the request message is used instead to track the worklist entry. Regardless of whether this field is used, the third-party system is notified when the worklist entry is marked Worked.	String	No
BusinessProcessName	BUSPROCNAME	The PeopleSoft Enterprise source business process name that includes the work item. The third-party system web service developer enters the appropriate PeopleSoft value for this field.	String	Yes

Schema Input Field Name	PeopleSoft Record Field Name	Description	Type	Required
ActivityName	ACTIVITYNAME	The PeopleSoft Enterprise source activity name of the source business process. The third-party system web service developer enters the appropriate PeopleSoft value for this field.	String	Yes
EventName	EVENTNAME	The PeopleSoft Enterprise source event name of the source activity. This field defines a routing event for PeopleSoft Workflow. The third-party system web service developer enters the appropriate PeopleSoft value for this field.	String	Yes
WorklistName	WORKLISTNAME	The PeopleSoft Enterprise source worklist name for the source event. The third-party system web service developer enters the appropriate PeopleSoft value for this field.	String	Yes
OperatorID	OPRID	The ID of the PeopleSoft Enterprise user who is assigned to the worklist entry. The third-party system web service developer enters the appropriate PeopleSoft value for this field.	String	Yes

Schema Input Field Name	PeopleSoft Record Field Name	Description	Type	Required
OriginatorID	ORIGINATORID	<p>This field can be the ID of the PeopleSoft manager who assigns the worklist entry to the user. The user who is assigned to the worklist entry can view this field. If the value is omitted, the default value for this field is the system ID that processed the PeopleCode to create the worklist entry.</p> <p>This is an optional field.</p>	String	No
Priority	WL_PRIORITY	<p>The priority of the worklist entry. Valid values are:</p> <ul style="list-style-type: none"> • blank—no priority • 1—high priority • 2—medium priority • 3—low priority <p>The default value for this field is blank. The third-party system web service developer enters the appropriate PeopleSoft value for this field.</p> <p>This is an optional field.</p>	String	No

Schema Input Field Name	PeopleSoft Record Field Name	Description	Type	Required
ApplicationData	PT_WL_CR_APP	A section in the request message that contains the case sensitive field names and values of the PeopleSoft Enterprise application worklist record. In addition to the key fields, which are required, the information from this field can be used to populate optional fields. If the application worklist record is missing or misspelled, an error is sent to the requesting system indicating that the worklist entry could not be created. The third-party system web service developer enters the appropriate PeopleSoft value for this field.	SubRecord with two fields, Name and Value	Yes
AdditionalData	PT_WL_CR_ADD	A section in the request message that can be used to pass additional information between systems. The third-party system web service developer enters the appropriate PeopleSoft value for this field. This is an optional feature that is useful only when a custom notification handler is used to process the worklist entry creation.	SubRecord with two fields, Name and Value	No

To use the AdditionalData section of the request message, PeopleSoft Enterprise application developers must design application-specific handlers that:

- Implement from the PeopleTools-delivered OnNotify class.
- Have access to the entire XML message.
- Call the PeopleTools-delivered handler to create the PeopleTools Worklist entry, the applications Worklist entry and the reply-to record.
- Do any additional required application processing.

Ensure that the PeopleTools-delivered notification handler is set to inactive, and the application handler is set to active.

Describing PT_WL_CREATE_RESPONSE Message

The alias for this reply message is CreateWorklistEntryResponse. This table provides information about the fields in this reply message:

Schema Output Field Name	PeopleSoft Record Name	Description	Type
RequestMessageID	PT_REQUEST_MSG_ID	The message identifier from the request message.	String
BusinessProcessName	BUSPROCNAME	The PeopleSoft Enterprise source business process name that includes the work item. The response message uses the value defined in the request message.	String
ActivityName	ACTIVITYNAME	The PeopleSoft Enterprise source activity name of the source business process. The response message uses the value defined in the request message.	String
EventName	EVENTNAME	The PeopleSoft Enterprise source event name of the source activity. This field defines a routing event for PeopleSoft Workflow. The response message uses the value defined in the request message.	String

Schema Output Field Name	PeopleSoft Record Name	Description	Type
WorklistName	WORKLISTNAME	The PeopleSoft Enterprise source worklist name for the source event. The response message uses the value defined in the request message.	String
InstanceID	INSTANCEID	A unique number that identifies the instance of the worklist entry. Value provided by PeopleSoft Enterprise.	Number
TransactionID	TRANSACTIONID	A number that identifies the worklist entry transaction. Value provided by PeopleSoft Enterprise.	Number
OperatorID	OPRID	The ID of the PeopleSoft Enterprise user who is assigned to the worklist entry. The response message uses the value defined in the request message.	String
InstanceStatus	INSTSTATUS	For a given worklist, determines the worklist status—available, selected, worked, canceled. Value provided by PeopleSoft Enterprise.	Number
WorkedOn	INSTWORKEDDTM	The date and time a worklist instance was worked by a user. Value provided by PeopleSoft Enterprise.	Number
ErrorCode	MESSAGENBR	A way to identify a specific type of error. Value provided by PeopleSoft Enterprise.	Number
ErrorDescription	MESSAGE_DESCR	A textual description of the error. Value provided by PeopleSoft Enterprise.	String

Schema Output Field Name	PeopleSoft Record Name	Description	Type
AdditionalData	PT_WL_CR_ADD	An optional section in the request message that is used by PeopleSoft Enterprise application developers to do additional processing, such as adding informational notes. This feature is available only when the assigned user selects the Programmatic option to mark the worklist entry as complete.	SubRecord with two fields, Name and Value

Describing GETWLINSTANCE Service Operation

GETWLINSTANCE is an optional web service operation that enables the third-party system to request status information about a worklist entry that it created for a PeopleSoft application user. This status information can be requested by the third-party system during the interim—between the time the worklist entry was created and before the worklist entry is marked Worked—or even after the worklist entry is marked Worked. This is a synchronous web service operation in which a response is immediately sent back to the requesting system. The request message uses the following fields as input and returns the status of the worklist entry as described in the PT_WL_GET_INSTANCE_RESP:

- Request_Message_ID
- Business Process Name
- Business Activity
- Business Event Name
- Worklist Name
- Instance ID
- Transaction ID

The GETWLINSTANCE service operation is available only if the worklist entry was created by a web service. PeopleSoft application developers can use the WorklistEntry class IsCreatedViaWebService property to determine if a worklist entry was created by a web service.

See “IsCreatedViaWebService” (PeopleCode API Reference).

Note: If a SOAP intermediary is able to change the value of WS-Address in the SOAP header, and you want to be able to use the GETWLINSTANCE service operation, you must populate the PT_REQUEST_MSG_ID field with a developer-defined value, and you must use the value as the key for this operation.

Describing PT_WL_GET_INSTANCE_REQ Message

The alias for this request message is GetWorklistEntryStatusData. The following table provides information about the fields in this request message:

Schema Input Field Name	PeopleSoft Record Name	Description	Type	Required
RequestMessageID	PT_REQUEST_MSG_ID	The message identifier that was defined by the third-party system web service developer for creating the worklist entry request message.	String	Yes
BusinessProcessName	BUSPROCNAME	The PeopleSoft Enterprise source business process name that includes the work item. The third-party system web service developer enters the appropriate PeopleSoft value for this field.	String	Yes
ActivityName	ACTIVITYNAME	The PeopleSoft Enterprise source activity name of the source business process. The third-party system web service developer enters the appropriate PeopleSoft value for this field.	String	Yes
EventName	EVENTNAME	The PeopleSoft Enterprise source event name of the source activity. This field defines a routing event for PeopleSoft Workflow. The third-party system web service developer enters the appropriate PeopleSoft value for this field.	String	Yes

Schema Input Field Name	PeopleSoft Record Name	Description	Type	Required
WorklistName	WORKLISTNAME	The PeopleSoft Enterprise source worklist name for the source event. The third-party system web service developer enters the appropriate PeopleSoft value for this field.	String	Yes

Describing PT_WL_GET_INSTANCE_RESP Message

The alias for this reply message is WorklistEntryStatusData. The following table provides information about the fields in this reply message:

Schema Input Field Name	PeopleSoft Record Name	Description	Type
RequestMessageID	PT_REQUEST_MSG_ID	The message identifier that was defined by the third-party system web service developer for creating the worklist entry request message.	String
BusinessProcessName	BUSPROCNAME	The PeopleSoft Enterprise source business process name that includes the work item. The response message uses the value defined in the request message.	String
ActivityName	ACTIVITYNAME	The PeopleSoft Enterprise source activity name of the source business process. The response message uses the value defined in the request message.	String

Schema Input Field Name	PeopleSoft Record Name	Description	Type
EventName	EVENTNAME	The PeopleSoft Enterprise source event name of the source activity. This field defines a routing event for PeopleSoft Workflow. The response message uses the value defined in the request message.	String
WorklistName	WORKLISTNAME	The PeopleSoft Enterprise source worklist name for the source event. The response message uses the value defined in the request message.	String
InstanceID	INSTANCEID	A unique number that identifies the instance of the worklist entry. Value provided by PeopleSoft Enterprise.	Number
TransactionID	TRANSACTIONID	A number that identifies the worklist entry transaction. Value provided by PeopleSoft Enterprise.	Number
InstanceStatus	INSTANCESTATUS	For a given worklist, determines the worklist status—available, selected, worked, canceled. Value provided by PeopleSoft Enterprise.	String

Schema Input Field Name	PeopleSoft Record Name	Description	Type
ResponseStatus	PT_WS_RESP_SENT	<p>Value provided by PeopleSoft Enterprise. Valid values are:</p> <ul style="list-style-type: none"> • 0—No such entry created. This may happen because the worklist entry creation request has not been processed. • 1: Entry is created successfully but it is not marked Worked. • 2: Entry was marked Worked and a response is sent to PeopleSoft Integration Broker for sending the response message to the originating third-party system. • 3: Entry was marked Worked but the response could not be sent to the originating third-party system. • 4: Entry was marked Worked and the response was successfully sent to the originating third-party system. 	Number
AdditionalData	PT_WL_CR_ADD	<p>An optional section in the request message that is used by PeopleSoft Enterprise application developers to do additional processing, such as adding informational notes. This feature is available only when the assigned user selects the Programmatic option to mark the worklist entry as complete.</p>	SubRecord with two fields, Name and Value

Submitting the Web Service Operation

Upon successful receipt of the create worklist entry web service request, PeopleSoft Integration Broker sends an HTTP acknowledgement to the requesting system. The request is sent to the Workflow application for creating a worklist entry for the identified user. If the worklist entry is created, the requesting system is not notified until the worklist entry is marked Worked. If the worklist entry cannot be created, PeopleSoft sends an error message to the requesting system. Upon successful receipt of the optional status request for the worklist entry, PeopleSoft Integration Broker sends an HTTP acknowledgement to the requesting system. The web service is sent to the Workflow application to obtain the status of the worklist entry, and the GetWorklistInstanceResp message is immediately returned to the requesting system.

Note: PeopleSoft application developers who want to create worklist entries locally should use the PeopleCode Notification Classes or the PeopleCode built-in function, TriggerBusiness Event. The requesting system is responsible for ensuring the request message is sent only once. If the request message is sent a second time with a unique request message ID, the Workflow application processes the second message as a new request. This could result in the same task appearing in the end user's worklist twice. If a request message is sent twice with the same unique ID in both messages, the first attempt creates the worklist entry and the second attempt causes an error message to be sent back to the requesting system. PeopleSoft does not provide web service operations for reassigning or canceling a worklist entry. PeopleSoft provides PeopleCode classes and a web service operation for PeopleSoft applications developers to obtain the worklist key values by using the message ID as a search parameter.

Understanding Routings and Security

As delivered, any external system can invoke the PeopleSoft PT_WORKLIST web service. **“Any-to-Local”** routings are delivered with both service operations so that once an external system discovers the web service, the third-party system can readily invoke the operations. Likewise, as delivered, external systems do not need to worry about authentication or security restrictions for invoking the web service. If you want to limit which systems or users can create worklist entries in your PeopleSoft application through a web service, you must either apply security or use a more restrictive routing, or do both.

See “Understanding Routing Definitions” (Integration Broker).

Related Links

“Understanding Setting Up Secure Integration Environments” (Integration Broker Administration)