

# PeopleSoft Human Capital Management 9.2

## PeopleSoft Global Payroll for Australia



G49606-01  
May 2026



PeopleSoft Human Capital Management 9.2 PeopleSoft Global Payroll for Australia,

G49606-01

Copyright © 1988, 2026, Oracle and/or its affiliates.

This software and related documentation are provided under a license agreement containing restrictions on use and disclosure and are protected by intellectual property laws. Except as expressly permitted in your license agreement or allowed by law, you may not use, copy, reproduce, translate, broadcast, modify, license, transmit, distribute, exhibit, perform, publish, or display any part, in any form, or by any means. Reverse engineering, disassembly, or decompilation of this software, unless required by law for interoperability, is prohibited.

The information contained herein is subject to change without notice and is not warranted to be error-free. If you find any errors, please report them to us in writing.

If this is software, software documentation, data (as defined in the Federal Acquisition Regulation), or related documentation that is delivered to the U.S. Government or anyone licensing it on behalf of the U.S. Government, then the following notice is applicable:

U.S. GOVERNMENT END USERS: Oracle programs (including any operating system, integrated software, any programs embedded, installed, or activated on delivered hardware, and modifications of such programs) and Oracle computer documentation or other Oracle data delivered to or accessed by U.S. Government end users are "commercial computer software," "commercial computer software documentation," or "limited rights data" pursuant to the applicable Federal Acquisition Regulation and agency-specific supplemental regulations. As such, the use, reproduction, duplication, release, display, disclosure, modification, preparation of derivative works, and/or adaptation of i) Oracle programs (including any operating system, integrated software, any programs embedded, installed, or activated on delivered hardware, and modifications of such programs), ii) Oracle computer documentation and/or iii) other Oracle data, is subject to the rights and limitations specified in the license contained in the applicable contract. The terms governing the U.S. Government's use of Oracle cloud services are defined by the applicable contract for such services. No other rights are granted to the U.S. Government.

This software or hardware is developed for general use in a variety of information management applications. It is not developed or intended for use in any inherently dangerous applications, including applications that may create a risk of personal injury. If you use this software or hardware in dangerous applications, then you shall be responsible to take all appropriate fail-safe, backup, redundancy, and other measures to ensure its safe use. Oracle Corporation and its affiliates disclaim any liability for any damages caused by use of this software or hardware in dangerous applications.

Oracle®, Java, MySQL, and NetSuite are registered trademarks of Oracle and/or its affiliates. Other names may be trademarks of their respective owners.

Intel and Intel Inside are trademarks or registered trademarks of Intel Corporation. All SPARC trademarks are used under license and are trademarks or registered trademarks of SPARC International, Inc. AMD, Epyc, and the AMD logo are trademarks or registered trademarks of Advanced Micro Devices. UNIX is a registered trademark of The Open Group.

This software or hardware and documentation may provide access to or information about content, products, and services from third parties. Oracle Corporation and its affiliates are not responsible for and expressly disclaim all warranties of any kind with respect to third-party content, products, and services unless otherwise set forth in an applicable agreement between you and Oracle. Oracle Corporation and its affiliates will not be responsible for any loss, costs, or damages incurred due to your access to or use of third-party content, products, or services, except as set forth in an applicable agreement between you and Oracle.

# Contents

## Preface

---

Understanding the PeopleSoft Online Help and PeopleBooks	i
Using and Managing the PeopleSoft Online Help	iv
PeopleSoft HCM Related Links	iv
Contact Us	iv
Follow Us	v

## 1 Getting Started with Global Payroll for Australia

---

Global Payroll Documentation	1
Global Payroll Application Design	1
Global Payroll Documentation Structure	1
Documentation Roadmap	2
Global Payroll for Australia Overview	3
Global Payroll for Australia Business Processes	3
Global Payroll for Australia Integrations	4
Global Payroll for Australia Implementation	4

## 2 Understanding Global Payroll for Australia

---

Global Payroll for Australia	1
Global Payroll for Australia Business Processes	1
Delivered Elements	5
Creation of Delivered Elements	5
Element Ownership and Maintenance	5
Naming Elements	7
Functional Area Codes	10
Element Type Codes (PIN_TYPE)	10
Archiving Data for Global Payroll for Australia	11
Additional Archiving Considerations	11
Viewing Delivered Elements	12

### 3 Setting Up Global Payroll for Australia

---

Processing Retroactive Payments	1
Determining Retro Pay Over 12 Months	1
Calculating the Months Exceeding 12 Months	1
Processing Retro Over 12 Months	2
Entering Additional Pay Group Information	2
Page Used to Enter Additional Pay Group Information	3
Pay Groups AUS Page	3
Entering Additional Calendar Information	5
Page Used to Enter Additional Calendar Information	5
Defining Triggers and Segmentation Events	5
Triggers	5
Segmentation Events	6
Identifying Proration Rules	6
Identifying Rounding Rules	7

### 4 Setting Up for Tax Reporting

---

Understanding the Setup for Taxation Calculations	1
Entering Information for Reporting Tax	2
Pages Used to Enter Information for Reporting Tax	2
Supplier Data Page	2
Review Payroll Tax Rates AUS Page	4
Viewing Tax Scales	5
Pages Used to View Tax Scales	5

### 5 Setting Up State Payroll Tax Reporting

---

Identifying Data for State Payroll Tax Reporting	1
Setting Up Group Pay Entities	1
Page Used to Set Up Group Pay Entities	1
Group Pay Entities AUS Page	1
Maintaining and Viewing Payroll Tax Tables	2
Pages Used to Maintain and View Payroll Tax Data	3

### 6 Managing Single Touch Payroll (STP)

---

Understanding Single Touch Payroll (STP)	1
Setting Up Single Touch Payroll (STP)	3
Pages Used to Set Up Single Touch Payroll (STP)	3
STP Category Setup AUS Page	4
STP SOVR Setup	7

STP Reconciliation Setup AUS	12
Single Touch Payroll - Phase 2	14
Income Type and Country Code	16
Child Support Deductions and Garnishees	16
Salary Sacrifice	17
Lump Sum Payments	18
Pages Used to Set Up Single Touch Payroll (STP)	19
Cessation Type	19
Brackets Data Page	20
Tax Offset Amount	21
Tax Treatment Code	22
STP Medicare Levy Surcharge Page	24
Update Event	25
STP 2.0 Update Event AUS Page	26
STP Payroll Event File AUS Page	29
STP Category Setup AUS Page	31
Generating Pay Event File	35
Pages Used to Generate Pay Event File	35
Understanding Pay Event Files and File Generation Process	35
STP Payroll Event Prep AUS Page	36
STP Payroll Event File AUS Page	38
STP PTD Override Page	44
Reconciling STP Data	45
Reconciling STP I Data	45
Page Used to Generate Data for STP I Reconciliation	46
Create Pmnt Summary Data AUS Page	46
Reconciling STP II Data	48
Pages Used to Generate Data for STP II Reconciliation	49
STP Reconciliation Setup AUS Page	49
STP Reconciliation AUS Page	50
STP Reconciliation Output - BIP Reports	52
Converting Data from STP 1 to STP 2	55
Page Used to Convert Data from STP I to STP II	58
STP Update/Final Event Data Conversion Page	58
Updating STP Event AUS	60
Page Used to Update STP Event Process	61
Personal Information Page	62
Wages & Taxation Page	63
Allowances Page	65
Deductions Page	65
Super Entitlement Page	66
Onboarding Page	67

## 7 Setting Up Banking and Recipient Processing

---

Understanding Banking and Recipient Processing Setup	1
Entering Additional Source Bank Information	1
Page Used to Enter Additional Source Bank Information	1
Source Bank Accounts AUS Page	1
Setting Up Multiple Source Banks by Debit Type	2
Pages Used to Set Up Multiple Source Banks by Debit Type	2
Pay Entity/Source Bank Page	2
Source Bank Override Page	3

## 8 Setting Up Payslips

---

Understanding Payslip Setup	1
Creating Payslip Templates and Messages	1
Pages Used to Create Payslip Templates and Messages	1
Payslip Setup Page	2
Earnings and Deduction Page	4
Messages AUS Page	5
Attaching Payslip Templates to Pay Groups	6

## 9 Defining Earnings

---

Understanding Earnings	1
Delivered Earnings Elements	1
Calculating Regular Pay	5
Calculating Overtime Earnings	6
Calculating Shift Earnings	6
Calculating Minimum and Maximum Hourly Rates and Earnings Limits	6
Checking the Minimum and Maximum Hourly Rate	6
Checking the Maximum Yearly Earnings Limit	7
Checking the Maximum Quarterly Earnings Limit	8
Calculating Earnings Based on Other Earnings	8
Calculating Amount Earnings	9
Using Flat Amounts	9
Using Formula-Based Amounts	9
Using Unprocessed Payee Level Amounts	9
Using Payee-Level System-Populated Amounts	10
Deducting from Regular Earnings	10
Calculating Rolling Average Earnings	11

Setting Up the Rolling Average Earnings Calculation	12
Creating Earnings Advance and Recovery	12
Selecting Hours for Holiday Earnings	12
Scheduling Earnings by Using Generation Control	13
Scheduling for Any Period	14
Scheduling for the Last Period Only	16

## 10 Defining Deductions

---

Understanding Deductions	1
Delivered Deduction Elements	1
Calculating Tax Deductions	4
Pre-Tax Deductions	4
Post-Tax Deductions	4
Non-Tax Deductions	4
Scheduling Deductions Using Generation Control	5
Checking Goal Amounts	5
Managing Garnishments	6
Pages Used to Manage Garnishments	7
Calculating Garnishment Deductions	7
Assign Garnishments AUS Page	8

## 11 Managing Taxation Processing

---

Understanding Taxation Processing	1
Understanding Retroactive Tax Processing	1
Calculating Taxes to Withhold for Retroactive Additional Payments	1
Understanding Periodic Tax for Leave Payments on Termination	8
Understanding Taxable Earnings Accumulators	9
Entering Information for Tax Processing	9
Pages Used to Enter Information for Tax Processing	9
Maintain Tax Data AUS Page	10
Review/Update Tax Scales AUS Page	15
Submitting the Electronic TFN Declaration	15
Page Used to Submit the Electronic TFN Declaration	16

## 12 Reporting State Payroll Tax Liabilities

---

Understanding State Payroll Tax Reporting	1
Running the State Payroll Tax Report	1
Page Used to Run the State Payroll Tax Report	1

## 13 Administering Superannuation

---

Understanding Superannuation Administration	1
Making Statutory and Customary Superannuation Deductions	2
Setting the Calculation Rule	3
Using Tier-Based Calculations	4
Using Percentage Based on Employee Contributions (Matching)	4
Accommodating Exemption Rules and Limits	5
Using Exemption Rule Checks	5
Applying Maximum Earnings Limits	5
Checking Age-Based Limits	6
Controlling Exemptions and Checking Limits	6
Accommodating Employee Options	7
Displaying Superannuation Information on the Payslip	7
Creating the ComSuper Payroll Interface File	8
Pages Used to Create the ComSuper Payroll Interface File	8
Payroll Interface File	8
Create Super Rpt File Page	9
Creating the SuperStream Files	10
Pages Used to setup and create the SuperStream Files	11
SuperStream Third Parties AUS Page	11
Pay Entities AUS Page	13
Third Party Detail Page	14
Recipient Details Page	16
Add Deduction Recipients AUS Page	16
Create SuperStream Files AUS Page	17
Create ComSuper SS Report Files AUS Page	19

## 14 Running Banking and Recipient Processes

---

Understanding Banking and Recipient Processing	1
Setting Up Additional Deduction Recipient Information	1
Pages Used to Set Up Additional Deduction Recipient Information	1
Add Deduction Recipients AUS Page	2
Deduction Recipients AUS Page	2
SuperEC Detail Page	5
Managing Electronic Fund Transfers	8
Page Used to Manage Electronic Fund Transfers	9
Generating the EFT Code	10
Fund Transfer - Electronic Page	10

Generating Recipient Payment Report Files	11
Page Used to Generate Recipient Payment Report Files	12
Create Recipient File AUS Page	12
Reporting Net Payment	13

## 15 Printing and Viewing Payslips

---

Printing Payslips	1
Overriding Payslip Delivery Options	1
Description of Processes in Payslip Job	1
Viewing Payslips Online	2

## 16 Using the General Ledger Interface

---

Understanding Payroll Data Processing for GLI or QSP	1
Linking Journal Types to GL Groupings	2
Page Used to Link Journal Types to GL Groupings	3
Understanding Accrued Salary Calculation	3
Understanding Leave Liability Calculation	4
Understanding Leave Liability Reporting	4
Annual Leave Liability Calculation for Hourly Accrual	5
Annual Leave Liability Calculation for Daily Accrual	6
Long Service Leave Liability Calculation for Weekly Accrual	6
Long Service Leave Liability Calculation for Monthly Accrual	7
Leave Liability Reversal When the Cost Centre Changes	7
Calculating State Payroll Tax Liability	7
Page Used to Calculate State Payroll Tax Liability	8
Running the GLI or QSP Process	8
Pages Used to Run the GLI or QSP Process	8
Understanding GLI and QSP Processes	9
Send Costs to GL AUS Page	9
Remapping ChartFields After Initial Calculation	11
Page Used to Remap ChartFields After Initial Calculation	12
GL Chartfield Remapping AUS Page	12

## 17 Defining Absence Rules

---

Understanding Absence Rules	1
Deducting Leave Hours from Regular Hours	1
Using Delivered Absence Primary Elements	1
Delivered Absence Entitlements	1
Delivered Absence Takes	2

Accruing Entitlement and Pro Rata Leave (Non-OGO)	3
Accruing and Taking Annual Leave	3
Accruing and Taking Long Service Leave	7
Accruing and Taking Sick Leave	11
Accruing and Taking Leaves During Foreign Employment Period	13
Accruing and Taking Other Types of Leave	14
Processing Other Leaves	14
Calculating and Taking OGO Long Service Leave	15
Page Used to Calculate and Take Long Service Leave	15
Understanding OGO Long Service Leave	15
Define Prior Service AUS Page	16
Calculating the Adjusted Service Date	17
Calculating OGO Part- and Full-Time Pro Rata and Entitlement	18
Taking OGO Long Service Leave	19
Paying Leave in Advance	20
Pages Used to Pay Leave in Advance	20
Advance Types AUS Page	20
Pay In Advance AUS Page	24

## 18 Understanding Termination Payment Management

---

Termination Processing	1
Termination Earning Elements	1
The Termination Section	1
Offset Days for Retroactive Termination Triggers	2
Delivered Termination Earnings	3
Calculation of Hourly and Daily Rates	5
Calculating the Hourly Rate	5
Calculating the Daily Rate	5
Resolution of Termination Earnings	6
Calculating Annual Leave Marginal Tax and Lump Sum A—Hours	6
Calculating Annual Leave Marginal Tax and Lump Sum A—Days	6
Calculating Annual Leave Loading Marginal Tax and Lump Sum A—Hours	7
Calculating Annual Leave Loading Marginal Tax and Lump Sum A—Days	7
Calculating Long Service Leave—Marginal Tax and Lump Sums A and B	7
Calculating Lump Sum D	8
Calculating Genuine Redundancy and Early Retirement Payments for Employees Over 65	9
Calculating Lump Sum C-Employment Termination Payment	13
Calculating Invalidity and Invalidity Post 94 Payments	14
Entering Final Hours	15

## 19 Reporting Workplace Gender Equality

---

Understanding the Workplace Gender Equality Report	1
Setting Up WGEA Remuneration Details	1
Pages Used to Set Up WGEA Remuneration Details	2
WGEA Remuneration Details AUS Page	2

## 20 Managing End of Year Reporting

---

Setting Earnings and Deduction Categories	1
Earnings and Deductions Categories and Values	1
Collecting FBT-Liable Earnings	2
Page Used to View and Adjust FBT-Liable Earnings	3
Rvw/Update Payee FBT Earns AUS Page	3
Reporting FBT for Terminated Employees	4
Generating Payment Summary Data	5
Pages Used to Generate/View Payment Summary Data	5
Review Pmnt Summary Data AUS Page	6
Printing the Payment Summary	9
Create Pmnt Summ Elec File AUS Page	9
Review Foreign Pmnt Data AUS Page	11
Using Self Service Reporting Framework	11
How to define and generate the Payment Summary Report	12
How to view and download the Payment Summary Report	15
Separating Eligible Termination Payment Data	15
Page Used to View ETP Data	16
Review/Update ETP Data AUS Page	16

## 21 Monitoring Salary Packaging Expenditure

---

Understanding Monitoring Salary Package Expenditure	1
Updating Expenditure Data for Employee Salary Packages	1
Page Used to Update Expenditure Data for Employee Salary Packages	2
Calculate Package Expenses AUS Page	2
Entering Salary Packaging Business Expenses	4
Reviewing Salary Package Expenditures	4
Pages Used to Review Salary Package Expenditures	4
Package Summary Page	5
Checking Package Expenditure Progress During the Year	9
Period Summary Page	9
Reconciling Payments at the End of the Package Period	11

## 22 Global Payroll for Australia Reports

---

Global Payroll for Australia Reports: A to Z	1
Global Payroll for Australia: Australian Bureau of Statistics Reports	1
Global Payroll for Australia: Additional Reports	2

# Preface

## Understanding the PeopleSoft Online Help and PeopleBooks

The PeopleSoft Online Help is a website that enables you to view all help content for PeopleSoft applications and PeopleTools. The help provides standard navigation and full-text searching, as well as context-sensitive online help for PeopleSoft users.

### Hosted PeopleSoft Online Help

You can access the hosted PeopleSoft Online Help on the [Oracle Help Center](#). The hosted PeopleSoft Online Help is updated on a regular schedule, ensuring that you have access to the most current documentation. This reduces the need to view separate documentation posts for application maintenance on My Oracle Support. The hosted PeopleSoft Online Help is available in English only.

To configure the context-sensitive help for your PeopleSoft applications to use the Oracle Help Center, see [Configuring Context-Sensitive Help Using the Hosted Online Help](#).

### Locally Installed PeopleSoft Online Help

If you're setting up an on-premises PeopleSoft environment, and your organization has firewall restrictions that prevent you from using the hosted PeopleSoft Online Help, you can install the online help locally. Installable PeopleSoft Online Help is made available with selected PeopleSoft Update Images and with PeopleTools releases for on-premises installations, through the [Oracle Software Delivery Cloud](#).

Your installation documentation includes a chapter with instructions for how to install the online help for your business environment. The documentation zip file may contain a README.txt file with additional installation instructions. See *PeopleSoft 9.2 Application Installation* for your database platform, "Installing PeopleSoft Online Help."

Installable PeopleSoft Online Help now includes PDF versions of each PeopleBook. For more information, see [Understanding Locally Installed PeopleSoft Online Help](#).

### Downloadable PeopleBook PDF Files

You can access downloadable PDF versions of the help content in the traditional PeopleBook format on the [Oracle Help Center](#). The content in the PeopleBook PDFs is the same as the content in the PeopleSoft Online Help, but it has a different structure and it does not include the interactive navigation features that are available in the online help.

### Common Help Documentation

Common help documentation contains information that applies to multiple applications. The three main types of common help are:

- Application Fundamentals
- Using PeopleSoft Applications
- Using and Managing the PeopleSoft Online Help

Most product families provide a set of application fundamentals help topics that discuss essential information about the setup and design of your system. This information applies to many or all applications in the PeopleSoft product family. Whether you are implementing a single application, some combination of applications within the product family, or the entire product family, you should be familiar with the contents of the appropriate application fundamentals help. They provide the starting points for fundamental implementation tasks.

In addition, the *PeopleTools: Applications User's Guide* introduces you to the various elements of the PeopleSoft Pure Internet Architecture. It also explains how to use the navigational hierarchy, components, and pages to perform basic functions as you navigate through the system. While your application or implementation may differ, the topics in this user's guide provide general information about using PeopleSoft applications.

Finally, *Using and Managing the PeopleSoft Online Help* (this guide) introduces you to the setup, features, and usage of the online help system.

## Field and Control Definitions

PeopleSoft documentation includes definitions for most fields and controls that appear on application pages. These definitions describe how to use a field or control, where populated values come from, the effects of selecting certain values, and so on. If a field or control is not defined, then it either requires no additional explanation or is documented in a common elements section earlier in the documentation. For example, the Date field rarely requires additional explanation and may not be defined in the documentation for some pages.

## Typographical Conventions

The following table describes the typographical conventions that are used in the online help.

Typographical Convention	Description
<b><u>Key+Key</u></b>	Indicates a key combination action. For example, a plus sign (+) between keys means that you must hold down the first key while you press the second key. For <b><u>Alt+W</u></b> , hold down the <b><u>Alt</u></b> key while you press the <b><u>W</u></b> key.
. . . (ellipses)	Indicate that the preceding item or series can be repeated any number of times in PeopleCode syntax.
{ } (curly braces)	Indicate a choice between two options in PeopleCode syntax. Options are separated by a pipe (   ).
[ ] (square brackets)	Indicate optional items in PeopleCode syntax.
& (ampersand)	When placed before a parameter in PeopleCode syntax, an ampersand indicates that the parameter is an already instantiated object. Ampersands also precede all PeopleCode variables.

Typographical Convention	Description
⇒	This continuation character has been inserted at the end of a line of code that has been wrapped at the page margin. The code should be viewed or entered as a single, continuous line of code without the continuation character.

## ISO Country and Currency Codes

PeopleSoft Online Help topics use International Organization for Standardization (ISO) country and currency codes to identify country-specific information and monetary amounts.

ISO country codes may appear as country identifiers, and ISO currency codes may appear as currency identifiers in your PeopleSoft documentation. Reference to an ISO country code in your documentation does not imply that your application includes every ISO country code. The following example is a country-specific heading: "(FRA) Hiring an Employee."

The PeopleSoft Currency Code table (CURRENCY\_CD\_TBL) contains sample currency code data. The Currency Code table is based on ISO Standard 4217, "Codes for the representation of currencies," and also relies on ISO country codes in the Country table (COUNTRY\_TBL). The navigation to the pages where you maintain currency code and country information depends on which PeopleSoft applications you are using. To access the pages for maintaining the Currency Code and Country tables, consult the online help for your applications for more information.

## Region, Country, and Industry Identifiers

Information that applies only to a specific region or industry is preceded by a standard identifier in parentheses. This identifier typically appears at the beginning of a section heading, but it may also appear at the beginning of a note or other text.

An example of a region-specific heading is: "(Latin America) Setting Up Depreciation"

### Region Identifiers

Regions are identified by the region name. The following are examples of region identifiers that may appear in PeopleSoft Online Help:

- Asia Pacific
- Europe
- Latin America
- North America

### Country Identifiers

Countries are identified by a three-letter country code. The following are examples of country identifiers that may appear in the PeopleSoft Online Help:

- ARG (Argentina)
- AUS (Australia)
- CAN (Canada)
- NLD (The Netherlands)

### Industry Identifiers

Industries are identified by the industry name or by an abbreviation for that industry. The following are examples of industry identifiers that may appear in the PeopleSoft Online Help:

- USF (U.S. Federal)
- E&G (Education and Government)

## Translations and Embedded Help

PeopleSoft 9.2 software applications include translated embedded help. With the 9.2 release, PeopleSoft aligns with the other Oracle applications by focusing our translation efforts on embedded help. We are not planning to translate our traditional online help and PeopleBooks documentation. Instead we offer very direct translated help at crucial spots within our application through our embedded help widgets. Additionally, we have a one-to-one mapping of application and help translations, meaning that the software and embedded help translation footprint is identical—something we were never able to accomplish in the past.

## Using and Managing the PeopleSoft Online Help

Select About This Help in the left navigation panel on any page in the PeopleSoft Online Help to see information on the following topics:

- Using the PeopleSoft Online Help.
- Managing hosted Online Help.
- Managing locally installed PeopleSoft Online Help.

## PeopleSoft HCM Related Links

[Oracle Help Center](#)

[PeopleSoft Online Help Home](#)

[PeopleSoft Information Portal](#)

[My Oracle Support](#)

[PeopleSoft Training from Oracle University](#)

[PeopleSoft Video Feature Overviews on YouTube](#)

Application Fundamentals: HCM Abbreviations

[PeopleSoft Spotlight Series](#)





## Contact Us

Send your suggestions to [psoft-infodev\\_us@oracle.com](mailto:psoft-infodev_us@oracle.com).

Please include the applications update image or PeopleTools release that you're using.

## Follow Us

---

Icon	Link
	<a href="#">Watch PeopleSoft on YouTube</a>
	<a href="#">Follow @PeopleSoft_Info on X.</a>
	<a href="#">Read PeopleSoft Blogs</a>
	<a href="#">Connect with PeopleSoft on LinkedIn</a>

---

# 1

# Getting Started with Global Payroll for Australia

## Global Payroll Documentation

This section discusses:

- Global Payroll application design.
- Global Payroll documentation structure.
- Documentation roadmap.

## Global Payroll Application Design

Because the structure of the Global Payroll documentation is similar to the design of the application, the best way to understand the documentation is to review the design of the application itself.

Global Payroll is composed of two complementary parts:

- A core payroll application that includes:
  - A payroll rules engine.
  - A payroll processing framework.
  - Processes and setup steps that apply to all countries.
- Country extensions that include:
  - Statutory and customary objects (payroll rules, payroll processes, reports, additional country-specific pages, and self-service applications).
  - Country-specific rules and elements.

## Global Payroll Documentation Structure

Like the application, the documentation for Global Payroll consists of two parts: a core book and separate country extension books.

### Core Documentation

Like the core portion of the application, which applies to all countries and enables you to develop rules and process a payroll regardless of location, the core book is country neutral. Thus, while it describes the core set of tools that you can use to develop a payroll, it doesn't discuss the local country rules that have been set up for you. For information about how PeopleSoft has extended core capabilities to meet local requirements, refer to the country extension documentation.

## Country Extension Documentation

Just as country extensions in the application address local needs, the country extensions in the documentation cover local functionality. This includes:

- Any core feature with local extensions.
- Country-specific rule setup.
- PeopleSoft-delivered rules and tables.
- Country-specific pages.
- Country-specific reports.
- PeopleSoft HCM setup, such as bank definitions, that varies by country.
- Implementation information that varies by country.

## Documentation Roadmap

The core and the country extension documentation complement each other, therefore, it is important to read both sets of documentation.

### What to Read When

You can approach the documentation in the following way:

- If a process setup is shared between the core application and the country extension, read the core documentation first and then the country extension documentation.  
  
For example, banking is a feature that you first define in the core application and then often continue in the country extension, because most country extensions have some type of banking functionality. You would first read the banking chapter in the core documentation and then the banking chapter in the country extension documentation.
- If a process is set up only in the core application, read the core documentation.
- If a process is set up only in the country extension, read the country extension documentation.

### Documentation Audiences

We've identified the following audiences for the documentation:

- **Technical**  
  
Technical readers who are interested in the technical design of the product should begin by reading the "Introducing the Core Application Architecture" section of the core documentation, as well as the batch processing information that is mentioned in many of the other sections.  
  
See PeopleSoft Global Payroll: Understanding the Core Application Architecture.
- **Functional**  
  
Functional readers who are interested in defining rules should begin by reading the country-specific functionality described in the country extension documentation. Functional readers can continue to learn about how to use the tools in the core application by reading the sections on defining payroll elements, such as earnings and deductions, in the core documentation.
- **Managerial**

Managerial readers should begin by reading the introduction sections of both the core documentation and the country extension documentation to get a high-level overview of the Global Payroll application.

**Note**

To fully understand Global Payroll, technical or functional persons who are involved in the product implementation should read the core documentation and the applicable country extension documentation in their entirety.

## Global Payroll for Australia Overview

Global Payroll for Australia delivers elements, rules, pages, processes, and reports that work with the core Global Payroll application to form a complete payroll package for Australia. You can define basic and non-basic earnings, as well as extra period payments and overtime. You can define deductions, such as union fees and garnishments. With Global Payroll for Australia, you can process loans and advances. You can track absence and vacation balances for employees. With Global Payroll for Australia, you can calculate termination pay, generate payslips, and process banking for employees.

### Related Topics

- [Global Payroll for Australia Business Processes](#)  
The following list is of the Global Payroll for Australia business processes:

## Global Payroll for Australia Business Processes

The following list is of the Global Payroll for Australia business processes:

- Taxation
- State Payroll Tax
- Superannuation
- Net-to-Gross Payments
- Banking and Recipient Processing
- Printing and Viewing Payslips
- Payroll Reporting
- General Ledger Interface
- Absences
- Terminations
- Salary Packaging Expenditure
- End-of-Year Reporting

We cover these business processes in the business process topics in this PeopleSoft Global Payroll for Australia document.

## Global Payroll for Australia Integrations

Global Payroll for Australia integrates with these applications through the core Global Payroll application:

- PeopleSoft Human Resources.
- PeopleSoft Time and Labor.
- PeopleSoft General Ledger.

We discuss integration considerations in the core Global Payroll document.

### Related Topics

- PeopleSoft Global Payroll: Understanding Payee Data
- PeopleSoft Global Payroll: Real Time Integration with Other PeopleSoft Applications
- PeopleSoft Global Payroll: Integrating Global Payroll with General Ledger

## Global Payroll for Australia Implementation

PeopleSoft Setup Manager enables you to generate a list of setup tasks for your organization based on the features that you are implementing. The setup tasks include the components that you must set up, listed in the order in which you must enter data into the component tables, and links to the corresponding PeopleBook documentation.

### Other Sources of Information

In the planning phase of your implementation, take advantage of all PeopleSoft sources of information, including the installation guides, table-loading sequences, and data models.

Refer to the *PeopleSoft HCM 9.2 - Reorganization of Component Interface Permissions* (Doc ID 2342162.1) article on My Oracle Support for a list of system-delivered CIs and their usage, the mapping of CIs and associated permission lists, and the mapping of CI permission lists and user roles.

See the product documentation for *PeopleTools: Setup Manager*

# 2

## Understanding Global Payroll for Australia

### Global Payroll for Australia

Global Payroll for Australia is a country extension of the core Global Payroll application. It provides the payroll rules, elements, and absence processes needed to run an Australian payroll.

### Global Payroll for Australia Business Processes

Global Payroll for Australia supports the following business processes:

#### Note

If you elect to use the delivered rules for Global Payroll for Australia, use only the employment instance in Human Resources.

- **Taxation.**  
Global Payroll for Australia comes with all the elements required to calculate a payee's tax correctly. Whatever the scenario—multiple payments within a calendar period, annualized tax, mid-period hires, or terminations—the system correctly calculates the tax.
- **State Payroll Tax.**  
Global Payroll for Australia administers payroll tax amounts based on the legislative requirements of the state revenue offices. This feature provides a report that you can use to calculate your state payroll tax liability.
- **Superannuation.**  
Global Payroll for Australia meets the requirements for superannuation by providing a number of super-related deductions. The calculation rules associated with each deduction reflect a particular type of superannuation deduction, such as a tier-based deduction or a percentage deduction based on employee contributions (matching).
- **Banking and Recipient Processing.**  
The banking process of Global Payroll brings together payroll data, pay entity source bank data, payee or recipient bank data. The electronic funds transfer (EFT) file creation process extracts data compiled by the banking process according to the type of EFT file that you are creating, merges it with data provided by the Australian country extension, and creates the file for transmission.
- **Off-Cycle Payments**  
Using the Off Cycle on Demand component, you can set up and process payments outside of the normal payroll schedule. Off-cycle transactions are usually made to correct prior payments, enter manual payments, or to make advance payments that can't wait until the next scheduled payroll run.

**! Important**

Advance payments do not replace Australia Pay in Advance functionality used for absences.

See PeopleSoft Global Payroll: Off Cycle Processing.

- **Payslips.**  
The payslip feature enables you to create and control payslips that display specified data. You can determine where the data appears and how it is formatted. You can override templates at lower levels, so you do not have to create multiple templates to cover every payslip scenario that you may have.
- **General Ledger Interface.**  
Building on the Global Payroll general ledger interface, the Australian country extension enables you to link journal types to general ledger (GL) groupings so you can report by journal type, calculate accrued salary and leave liability, report leave liability, calculate state payroll tax liability, and run the GLI or QSP process.
- **Absences.**  
PeopleSoft delivers predefined rules for processing annual and long-service leave, OGO long-service leave, sick leave and absences generally defined as *other leaves*, such as maternity or jury duty. You can modify many of these rules to reflect absence policies that are specific to your organization or to labour agreements that may be in force for employees
- **Terminations.**  
Global Payroll for Australia comes with a termination section that enables you to ensure all legal obligations are met. It gives you the flexibility to make changes that suit your specific business practices.
- **Salary Packaging Expense Monitoring.**  
The integration of the Salary Packaging business process in PeopleSoft Human Resources with Global Payroll for Australia enables you to enter actual expenditures against a budgeted salary package. When you define components, you use the Expense Data page to identify whether the component is administered as a deduction, earning, or expense.
- **End-of-Year Reporting.**  
The End-of-Year Reporting feature enables you to set up the data that appears on the Payment Summaries, which you provide at the end of the year or on termination. It enables you to process and report FBT-liable earnings, generate payment summary data, print payment summaries, and create the payment summary electronic file for the Australian Tax Office.

**Related Topics**

- [Understanding Taxation Processing](#)  
The Australian country extension to Global Payroll comes with all the elements required to calculate a payee's tax correctly. The system calculates taxes in a variety of situations, such as multiple payments within a calendar period, annualized tax, mid-period hires, retroactive taxation, and terminations.

- [Understanding State Payroll Tax Reporting](#)  
The State Payroll Tax report provides detailed information about the earnings, benefits, deductions, and expenses that are identified as payroll taxable or payroll tax exempt. Details are also provided for termination payments that are payroll tax exempt.
- [Running the State Payroll Tax Report](#)  
The GPAU\_SPT\_RPT Application Engine process extracts data for state payroll tax reporting, and that data is formatted as a report by the GPAUT01 Structured Query Report.
- [Understanding Superannuation Administration](#)  
Correct superannuation calculation and output involves the following input:
- [Making Statutory and Customary Superannuation Deductions](#)  
The following deductions are for the common super contributions.
- [Understanding Banking and Recipient Processing](#)  
The banking process of Global Payroll combines payroll data, pay entity source bank data, and payee or recipient bank data. The EFT file creation process extracts data compiled by the banking process according to the type of EFT file that you are creating, merges it with data provided by the Australian country extension, and creates the file for transmission.
- [Printing Payslips](#)  
You print payslips by running the GPAUPY01 SQR process (select **Global Payroll & Absence Mgmt**, and then **Payslips**, and then **Create and Print Payslips AUS**).
- [Viewing Payslips Online](#)  
If you license PeopleSoft ePay, employees can view an online self-service version of the payslip. To aid in resolving questions that employees have about their payslips, the payroll administrator can view employees' self service payslips in an online view that replicates the employees' view. Both the online view and the printed payslip are based on the layout defined in the payslip template.
- [Understanding Payroll Data Processing for GLI or QSP](#)  
The Global Payroll results integration point uses PeopleSoft Integration Broker to send payroll results to the Global Payroll Accounting Line Stage Record (GP\_ACC\_LINE\_STG). The data is sent using the General Ledger Transaction Prep application engine process (GP\_GL\_PREP), and uses the Post Global Payroll to General Ledger batch rule (GP\_POST\_GL).
- [Understanding Absence Rules](#)  
Managing absences and periods of leave in Australia is complex, because business practices and state legislation vary on issues such as the rate and frequency at which leave accrues and whether it becomes immediate entitlement or starts as pro rata leave.
- [Termination Processing](#)  
When an employee's services are terminated, regardless of the reason, the employer must make mandatory payments to the employee, depending on the circumstances. Payments can consist of:
- [Termination Earning Elements](#)  
The Termination section comprises a formula, 21 earning elements, and a single deduction. They ensure that all legal obligations are met and that you have the flexibility to make changes to suit your business practices. You need to maintain only a few of the formulas upon which the earnings are based. You also have to set the values of some of the variables that the formulas use.
- [The Termination Section](#)  
The Termination section contains a conditional formula, TER FM TERM CHECK, to check if there is either a termination date in the pay period or a termination action date in the period. The formula checks for both to accommodate a situation in which you may have not entered the termination until the pay period after the period in which the termination

occurred. If the check is only on the termination date, the section is not processed, because that date is outside the current pay period begin and end dates.

- [Offset Days for Retroactive Termination Triggers](#)  
When you define retro triggers on the Trigger Definitions-Field Values page, you can enter a positive or negative number in the Offset Days field to increase or decrease the retro trigger effective date in relation to the date of a field value change. For example, if you enter -1 in the Offset Days field for one of the values listed in the Field Values group box, and you retroactively enter that value into the database with an effective date of January 1, 2000, the system automatically adjusts the trigger effective date to December 31, 1999 (one day earlier). The system then processes pay periods going back to December 1999 rather than January 2000. Global Payroll for Australia uses the offset days feature to define the triggers for retroactive terminations entered in the JOB record using the Action field:
- [Delivered Termination Earnings](#)  
This table lists the earning elements resolved in the Termination section and each earning calculation rule. Individual elements are later discussed in sufficient detail for you to understand how they are correctly resolved. The code (*gc*) in the first column indicates that the earning has a generation control:
- [Calculation of Hourly and Daily Rates](#)  
All the rates are either hourly or daily. For both, we have allowed for the situation in which employees have salary packages and need to have their hourly or daily rate calculated from their total package value.
- [Resolution of Termination Earnings](#)  
This section discusses each of the earning elements in the Termination section and shows how they are resolved.
- [Understanding Absence Rules](#)  
Managing absences and periods of leave in Australia is complex, because business practices and state legislation vary on issues such as the rate and frequency at which leave accrues and whether it becomes immediate entitlement or starts as pro rata leave.
- [Understanding Monitoring Salary Package Expenditure](#)  
The Administer Salary Packaging business process in Human Resources enables you to monitor and project employee expenses during a salary package period. It also provides tools to ensure that actual spending, for both employees and the organization, stays within the limits of budgeted salary packages. You can view package expenditures online as they take place, or generate reports that detail employee expenditures from their package budgets.
- [Setting Earnings and Deduction Categories](#)  
The earnings and deductions categories determine where earnings and deductions appear on the payment summary.
- [Collecting FBT-Liable Earnings](#)  
The ATO requires that you report FBT-liable earnings when the gross-up value (of all FBT-liable earnings) exceeds a minimum figure. To have the system calculate the reportable fringe benefits amount for inclusion on the payment summary, you run a collect process.
- [Generating Payment Summary Data](#)  
When data preparation is complete, you can generate the payment summary data for each employee. You can view the data before printing payment summaries for issue to payees.
- [Separating Eligible Termination Payment Data](#)  
If the system detects Lump Sum C ETPs during the Create Payment Summary process, it stores the data separately.

## Delivered Elements

Global Payroll defines each business process for Australia in terms of delivered elements and rules. Some of these elements and rules are specifically designed to meet legislative requirements. Others support common or customary payroll practices.

### Creation of Delivered Elements

All of the elements and rules delivered as part of your country extension were created using the core application—the same application that you use both to create additional elements or rules, and to configure existing elements delivered as part of the Global Payroll application. Because the tools needed to redefine or create new payroll elements are fully documented in the core application PeopleBook, that information does not appear here. Instead, this PeopleBook briefly reviews the relationship between the core application (which contains the tools that you need to define your own elements and rules) and the country extensions (which contain country-specific rules and elements defined by PeopleSoft).

The core application has the following characteristics:

- It consists of a payroll rules engine—a flexible tool that enables you to define the rules and elements of the payroll system and execute payroll and absence calculations.

Global Payroll does not embed payroll-specific logic or computations in application code. Instead, it specifies all business application logic—such as earnings, deductions, absences, and accumulators—in terms of payroll rules and elements. Global Payroll enables you to enter and maintain payroll rules through a set of pages, and it offers a comprehensive set of features that enable you to work in your preferred language or currency.

- It provides a payroll processing framework—a flexible way to define and execute payroll and absence processing flows, such as calendars, run types, pay periods, and process lists.

Country extensions have the following characteristics:

- They are built using the core application.
- They consist of statutory and customary objects (country-specific payroll rules, elements, payroll processes, reports, pages, and self-service applications).

### Element Ownership and Maintenance

The delivered elements and rules of the Global Payroll country extension can be classified according to whether they are owned and maintained by you or by PeopleSoft. Some elements and rules are maintained exclusively by PeopleSoft and cannot be modified, while others can be configured to meet requirements unique to each organization.

#### Element Ownership in Global Payroll

There are five categories of element ownership:

Field or Control	Description
<b>PS Delivered/Maintained</b> (PeopleSoft-delivered and maintained)	Elements delivered and maintained on an ongoing basis by PeopleSoft.

Field or Control	Description
<b>PS Delivered/Not Maintained</b> (PeopleSoft-delivered but not maintained)	Elements delivered by PeopleSoft that must be maintained by the organization. This category consists primarily of either customary (or non-statutory) rules and statutory elements that organizations may want to define according to different interpretations of the rules. Although PeopleSoft may occasionally update elements defined as PS Delivered/Not Maintained, you are not required to apply these updates.
<b>Customer Maintained</b>	Elements created and maintained by the organization. PeopleSoft does not deliver rules defined as Customer Maintained.
<b>PS Delivered/Customer Modified</b> (PeopleSoft-delivered and customer-maintained)	Elements that were originally PS Delivered/Maintained elements over which the organization has decided to take control. This change is irreversible.
<b>PS Delivered / Maintained / Secure</b>	Delivered elements that the organization can never modify or control.

### Element Ownership in Global Payroll for Australia

Of the five ownership categories listed in the previous section, only PS Delivered/Maintained and PS Delivered/Not Maintained are used to define Australian elements. Although Global Payroll for Australia delivers some elements as PS Delivered/Maintained, most elements are designated PS Delivered/Not Maintained. This enables you to modify, update, and reconfigure the delivered elements to meet needs that are specific to your organization.

#### Note

In general, Global Payroll for Australia uses the ownership category PS Delivered/Not Maintained unless the modification of an element might interfere with calculations that satisfy legislative requirements. The benefits of this approach are evident if you consider the setup of delivered accumulators. Because balance accumulators (for example, those storing taxable gross on a year-to-date basis) must be set up to comply with the legislative requirement for calculating taxes, Global Payroll for Australia defines them as PS Delivered/Maintained. You cannot modify or directly add new elements to them. However, you can add new elements to these accumulators by using the delivered segment accumulators, which serve as the entry point into the system. They are not maintained by PeopleSoft. When you define a new earning or deduction, you can assign the element to a segment accumulator, and the segment accumulator automatically contributes to the correct balance accumulators.

In the following table of elements supplied with Global Payroll for Australia, the element ownership is PS Delivered/Not Maintained, with exceptions shown in the right-hand column.

**Note**

The following element types have no exceptions and are therefore not shown in the table: Absence Entitlement, Absence Take, Count, Duration, Date, Element Group, Earning, Generation Control, Historical Data Rule, Process, Rate Code, Rounding Rule, and Writable Array.

Element Type	Exceptions
Accumulators	<ul style="list-style-type: none"> <li>Total Tax for the Period.</li> <li>HELP Earnings - Annualized.</li> <li>Total Earns: Annualized, Leave Loading, Lump Sums A, B, D &amp; E, Lump Sum C Taxable &amp; Non Tax, and Marginal.</li> <li>Period to Date (PTD): Earnings, HELP, Leave Loading, SFSS Amount, Tax Amount, and HELP and SFSS Marginal.</li> <li>Year-to-Date (YTD) Earns - Leave Loading.</li> </ul>
Array	<ul style="list-style-type: none"> <li>Payee's Normal Gross Earnings, EE Tax Detail (employee tax detail).</li> <li>Tax Scale: Details &amp; Rates.</li> </ul>
Bracket	Australian: FTB Rates, HELP Rates, and SFSS Rates.
Deduction	<ul style="list-style-type: none"> <li>Annualized Tax, HELP Amount.</li> <li>Lump Sum: A, B, C, and E Tax.</li> <li>Marginal Tax, SFSS Amount.</li> </ul>
Formula	<ul style="list-style-type: none"> <li>Error: Formula for AR EARN ALL, Retrieving EE Tax Data, Retrieving Tax Rates Dtl &amp; Rates.</li> <li>TAX FM (PIN_NM): All TAX formulas.</li> <li>TER FM (PIN_NM): LSL Termination Calculation, Post 1978 Accrual LSL, Post 1993 Accrual LSL .</li> </ul>
Section	Tax Deduction Section, TAX - DED
Variable	<ul style="list-style-type: none"> <li>Balance Group ID, Message Set No for Aust - Batch, Result of Proration Work Day.</li> <li>TAX VR (PIN_NM): All TAX variables except: Balance Group ID, Pay Entity.</li> <li>TER VR (PIN_NM): Lump Sum D Initial Value, Lump Sum D Yearly Value.</li> </ul>

## Naming Elements

To understand how delivered payroll elements function in the system, you need to understand their names. The naming convention for PeopleSoft-delivered elements enables you to determine how an element is used, the element type, and even the functional area it serves. Depending on whether the element is a primary element, a component of a primary element, or a supporting element, one of the following naming conventions applies.

### Supporting Elements

For supporting elements, such as variables, formulas, dates, durations, and so on, PeopleSoft uses the following naming convention: FFF (or FF) TT NAME.

- FFF (or FF) is the functional area code.  
See [Functional Area Codes](#).
- TT is the type of supporting element.  
See [Element Type Codes \(PIN\\_TYPE\)](#).
- NAME (or NAME NAME) indicates the purpose of the element.  
The number of NAME components may vary.

For example, in the garnishment variable GRN VR PROC STATUS, GRN stands for *garnishment*, VR stands for *variable*, and PROC STATUS stands for *process status*. With a maximum of 30 characters, the element's description (DESCR) field provides details about the element's purpose.

### Primary Elements

Primary elements—such as earnings, deductions, absence take, and absence entitlement elements—often do not contain functional area codes or element type codes in their names. This is because primary elements have names, based on Australian terms, that identify their function and element type without the use of additional codes. For example, the name of the earning element PAY IN LIEU clearly identifies the element as an earning—specifically, as payment in lieu of notice.

### Additional Information about Elements

Many Australian elements contain abbreviations that provide additional information about their purpose (beyond what the functional area codes and element type codes provide). For example, consider the following duration elements: PSH DR BS PRD D and PSH DR BS PRD Y. The functional area code PSH indicates that these elements are used for Prior Service History elements, and the element type code DR identifies them as duration elements. The abbreviations BS, PRD, and D and Y provide additional information about how each element measures periods of time. The durations are of between-service (BS) periods (PRD) expressed in days (D) and in years (Y). As you become more familiar with the payroll rules created for Australia, these abbreviations enable you to identify the role of each element.

The following table lists the most common abbreviations used in the names of Australian elements.

Abbreviation	Meaning
ACCR	Accrual.
ADDL	Additional.
AL	Annual leave (also ANN).
AMBR	Adjustment accumulator member.
AMT	Amount.
BAL	Balance.
BMBR	Balance accumulator member.
BSD	Based (for example, TIERBSD for <i>tier-based</i> ).
CHK	Check.
DTL	Detail.
DYS	Days.
EE	Employee.
EMBR	Entitlement accumulator member.

Abbreviation	Meaning
ENT	Entitlement.
ER	Employer.
ETP	Eligible termination payment.
GRP	Group.
HPH	Hours per hour (entitlement).
HR or HRLY	Hours or hourly.
LIAB	Liability.
LL	Leave loading.
LST	Last.
LUMP[*]	Lump sum [A, B, C, D or E].
MAR	Marginal (tax).
MTH	Month.
NML	Normal.
OVRD	Override.
PD or PRD	Period (or product for PRD).
PRO	Pro rata.
PUB	Public (as in <i>public holiday</i> ).
ROLL	Rolling (average).
RT	Rate.
SCL	Scale (for example, TXSCL for <i>tax scale</i> ).
SPE	Service period end.
SPS	Service period start.
SPT	State payroll tax.
TKE	(Absence) take.
TMBR	Take accumulator member.
WKF	Weeks federal.
WKO	Weeks other (non-federal).

### Component Names (Suffixes)

In Global Payroll for Australia, suffixes are used to name the components of earnings and deductions elements. For example, when you create an earning or deduction element in Global Payroll, you define the components that make up the element, such as base, rate, unit, and percentage. The system automatically generates the components and accumulators for the element based on the calculation rule or accumulator periods. The system also names the components and accumulators by appending a suffix to the element's name.

For example, suppose that you define the earning element named EARN1 with the following calculation rule:

$$\text{EARN1} = \text{Rate} \times \text{Unit}$$

The system automatically creates two additional elements for the components in the calculation rule: a rate element called EARN1\_RATE and a unit element called EARN1\_UNIT. In Global Payroll for Australia, all suffixes fall into one of the following types:

- Separator.
- Earnings and deductions and absence entitlement component suffixes.
- Earnings and deductions and absence entitlement accumulator suffixes.
- Deduction arrears component suffixes.
- Deduction arrears accumulator suffixes.
- Recipient suffixes.

### ① Note

To view the suffixes used for Australia, select **Set Up HCM**, and then **Product Related**, and then **Global Payroll & Absence Mgmt**, and then **System Settings**, and then **Element Suffixes**.

## Functional Area Codes

The following table contains the functional area codes used in the names of Australian elements.

Functional Area Code	Description
ABS	Australian Bureau of Statistics.
ANN	Annual leave.
AUS	Australia (used for elements common to multiple features).
DED	Deduction.
EOY	End of year.
ERN	Earnings.
GLI	General Ledger Interface.
GRN	Garnishment.
LIM	Limit.
LSL	Long service leave.
LVE	Leave.
PPL	Paid parental leave.
PSH	Prior service history.
RTO	Retro.
SCK	Sick leave.
SP	Salary packaging.
TAX	Tax.
TER	Termination.

## Element Type Codes (PIN\_TYPE)

Many element types, particularly supporting elements, are identified by the type code in their names. For example, the FM in AUS FM LSTSEG identifies the element as a formula.

You can view all the element types in the search page by selecting **Set Up HCM**, and then **Product Related**, and then **Global Payroll & Absence Mgmt**, and then **System Settings**, and then **Element Types**. Because not all element types are delivered for Australia, some these codes do not appear in the names of Australian elements.

## Archiving Data for Global Payroll for Australia

PeopleSoft Global Payroll for Australia delivers an archiving tool called the Data Archive Manager with a predefined archive object (GPAU\_RSLT\_ARCHIVE) and an archive template (GPAURSLT) that you can use to archive your payroll results data. The delivered archive template uses queries to select and store data by calendar group ID (CAL\_RUN\_ID field).

### Note

Please use extreme caution when making changes to delivered archive objects, queries, or templates. Any modifications can result in the loss of important data.

See [Archiving Data for Global Payroll for Australia](#).

## Additional Archiving Considerations

The following PeopleSoft Global Payroll for Australia result data is not included in the GPAU\_RSLT\_ARCHIVE archive object because it is not associated with a calendar group ID:

Result Data Type	Data Location
Pay Leave in Advance	<ul style="list-style-type: none"> <li>GPAU_ABSADV_CAL</li> <li>GPAU_ABSRET_CAL</li> <li>GPAU_ABSADV_SEG</li> <li>GP_ABSEVT_SGPAU</li> </ul>
CEMTEX Electronic Funds Transfer Results	<ul style="list-style-type: none"> <li>GPAU_EFT_CMX_HD</li> <li>GPAU_EFT_CMX_TL</li> <li>GPAU_EFT_CMX_DT</li> </ul>
Recipient Report Results	<ul style="list-style-type: none"> <li>GPAU_RCPPAY_DTL</li> <li>GPAU_RCPPAY_HDR</li> <li>GPAU_RCPPAY_FTR</li> </ul>
End of Year Payment Summary Results	<ul style="list-style-type: none"> <li>GPAU_EE_PSM</li> <li>GPAU_EE_ETP</li> </ul>
Payment Summary Exception Results	GPAU_PSM_EXCEPT
State Payroll Tax Results	GPAU_SPT_SUMM
FBT Results	GPAU_EE_FBT

If you want to archive this data, you can set up new archive objects, queries, and templates using the Data Archive Manager, or you can use your own archiving solution.

See the product documentation for *PeopleTools: Data Management*

## Viewing Delivered Elements

The PeopleSoft system delivers a query that you can run to view the names of all delivered elements designed for Australia. Instructions for running the query are provided in the *PeopleSoft Global Payroll 9.1 PeopleBook*.

### Related Topics

- [PeopleSoft Global Payroll: Understanding How to View Delivered Elements](#)

# 3

## Setting Up Global Payroll for Australia

### Processing Retroactive Payments

The default retro method and the on-conflict retro method for Australia are both forwarding. You set this on the Country Setup page.

The core retro functionality suits all Australian requirements except the requirement to apply a different tax rate to retro payments that relate to periods more than 12 months before the date the forwarded retro payment is made.

### Determining Retro Pay Over 12 Months

To meet this requirement, the PeopleSoft system provides the formula RTO FM SET OVRDSET, which uses the duration RTO DR MTH ARREARS to determine if a period of more than 12 months has elapsed between any of the periods being retroactively paid and the payment date of the retro. If any elapsed period is greater than 12 months, the system selects a new override set—also provided by the PeopleSoft system—to forward all the processed earnings to the single new earning, RETRO12MTH, that the system taxes at the lower rate.

These are lump sum E payments, so the RETRO12MTH earning contributes to accumulator PD LUMP E as well as AUS GROSS, PAYROLL TAX PROV (Provision for Payroll Tax) and its own automatically assigned calendar and fiscal period, month, quarterly, and yearly accumulators.

The system provides one retro processing definition, AU RETRO (which is set to forwarding) and two override sets.

#### Note

If you add any earnings that can be retroactively paid, you need to add them to both override sets and to the appropriate accumulators.

### Calculating the Months Exceeding 12 Months

The duration calculation result determines which override set to use by calculating the duration for each period. When the duration exceeds 12 months, the second override set applies.

This diagram shows that the system calculates the duration for each period and uses the second override set when the total duration exceeds 12 months.

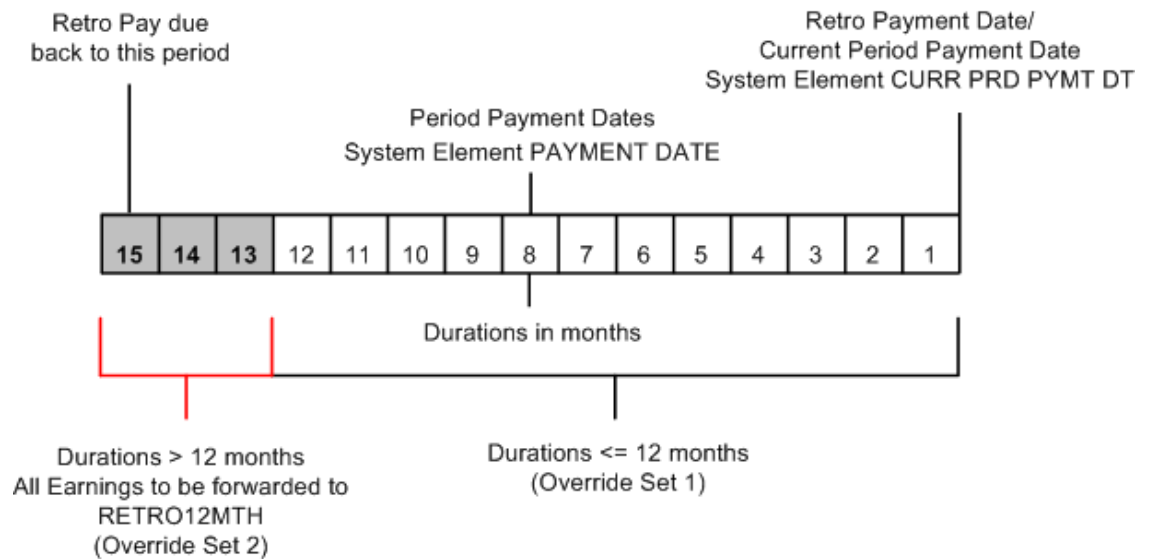

## Processing Retro Over 12 Months

Here are the processing steps:

1. Formula RTO FM SET OVRDSET—the formula specified on the Retro Process Overrides AU RETRO page—is called for each pay period identified for retro processing.

The formula uses duration RTO DR MTH ARREARS to calculate the months between the pay date of each pay period identified for retro processing (the duration From date—system element PAYMENT DATE) and the date the retro is to be paid (the duration To date—system element CURR PRD PYMT DT).

2. If the duration is 12 months or less, the formula returns 1, and the system uses override set 1 for forwarding retro; if the duration is greater than 12 months, the formula returns 2, and the system uses override set 2 for forwarding retro.

For each period that's more than 12 months before the retro payment date, the system forwards all the retro earnings to the single earning element RETRO12MTH.

3. The sum of the earnings forwarded to the single earning RETRO12MTH represents a lump sum E payment, and the tax calculation uses the appropriate rate on the earning.

## Entering Additional Pay Group Information

To enter additional pay group information, use the Pay Groups AUS (GPAU\_PYGRP\_DTL) component.

To accommodate local requirements, the Pay Groups AUS page enables you to specify payslip templates, salary packaging frequency, and leave paid in advance options.

This topic discusses how to enter additional information.

## Page Used to Enter Additional Pay Group Information

Page Name	Definition Name	Usage
<a href="#">Pay Groups AUS Page</a>	GPAU_PYGRP_EXT	Specify payslip template, salary packaging frequency, and leave paid in advance options.

## Pay Groups AUS Page

Use the Pay Groups AUS page (GPAU\_PYGRP\_EXT) to specify payslip template, salary packaging frequency, and leave paid in advance options.

Navigation:

**Set Up HCM**, and then **Product Related**, and then **Global Payroll & Absence Mgmt**, and then **Framework**, and then **Organizational**, and then **Pay Groups AUS**, and then **Pay Groups AUS**

This example illustrates the fields and controls on the Pay Groups AUS page. You can find definitions for the fields and controls later on this page.

The screenshot shows the 'Pay Groups AUS' page with the following details:

- Pay Group:** KAMONTHLY (Monthly Pay Group)
- Pay Entity:** KAAUSBI (Australian Business Institute)
- Definition:** Find | View All | First 1 of 1 Last
- \*Effective Date:** 01/01/2000
- Templates:** Payslip KA AU HRLY (Base Template)
- Salary Packaging:** Pay Frequency M (Monthly)
- Leave Paid in Advance:** Regular Run Type KAPAYROLL (Australian Payroll)

### Templates

Enter the name of the payslip template that the system uses for this pay group.

### Salary Packaging

Select the default pay frequency for the salary-packaged employees in the pay group. An equivalent field exists in Human Resources in case an organization uses Human Resources but not Global Payroll. The pay frequency that you enter here appears by default as the pay frequency on the Salary Packing Pay Calendar Table page.

### Leave Paid in Advance

Within the general structure of Global Payroll calendars, periods, and calendar groups, the system has to determine the calendar group in which an advance should be paid. To determine the appropriate calendar group, the system looks for a calendar that uses the organization's regular run type, which you identify in the Regular Run Type field on this page. A calendar group can contain multiple calendars, each with potentially different periods and payment dates. In determining the calendar group in which to include an advance, the system also looks at the calendars in the group to see when they are being paid.

The following diagram illustrates the selection of the correct calendar. In this example, a leave begins on January 18, 2001. In the January calendar group, the Q4BONUS calendar with a January 15 payment date cannot be used because its run type is Bonus rather than Regular, and the JANPAY calendar with a January 30 payment date cannot be used because the system is configured to make the payment before the absence begins. Therefore, the system must go back to December and look at the DECPAY calendar in the December calendar group. This calendar has a Regular run type and a pay date of December 12, 2000, so it is used to make the advance payment.

**Note**

In the example, the Advance Type page shows that the Advance Calendar Group for the advance type is Payment Prior to Absence Begin (PPAB). This refers to a payment date that is prior to the absence begin date—not a payment period that is prior to the absence begin date. For the prior payment period, you use the Period Prior to Absence option.

This diagram shows an example of selecting the calendar group in which to pay a leave advance.

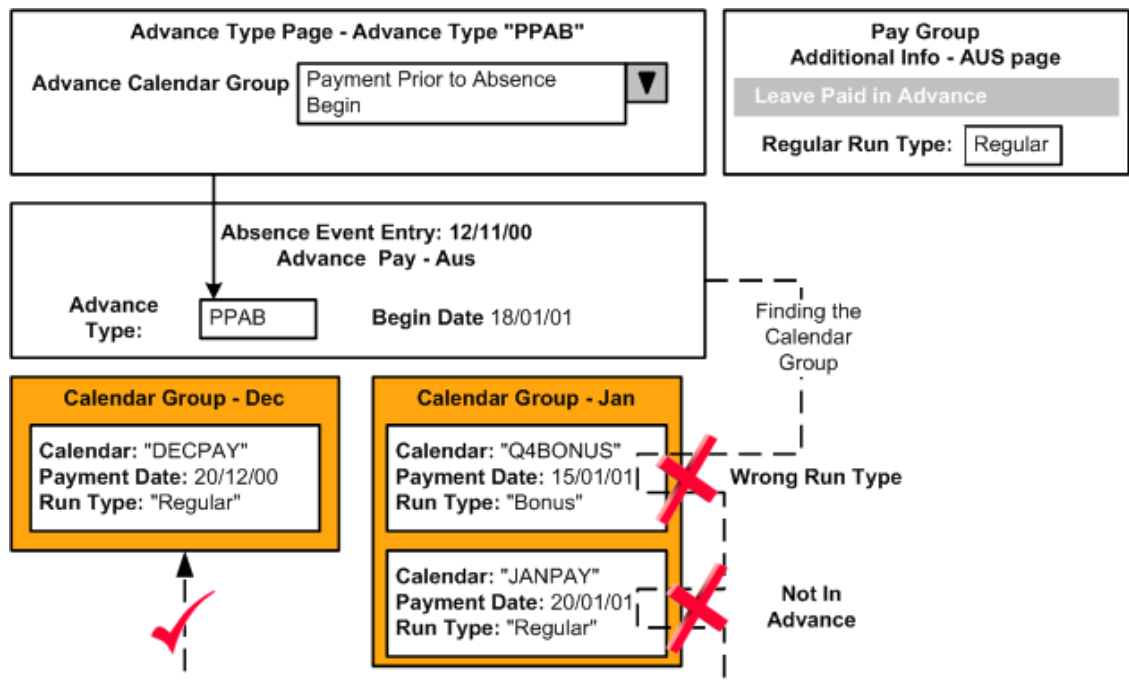

## Entering Additional Calendar Information

To set up additional calendar information, use the Calendar Groups AUS (GPAU\_CAL\_RUN) component.

To comply with local requirements, the Australian Information page enables you to mark a calendar group's calendars that can be advanced.

### Page Used to Enter Additional Calendar Information

Page Name	Definition Name	Usage
Calendar Groups AUS Page	GPAU_CAL_RUN_DTL	Mark a calendar group's calendars that can be advanced. The page displays the pay entities, pay groups, and calendars entered on the Calendar Group ID page. (You can add to them if necessary.) To enable the system to advance a calendar, select the <b>Include in Advance</b> check box.

## Defining Triggers and Segmentation Events

These tables list triggers and segmentation events for Australia.

### Triggers

The following table lists triggers for Australia:

Record (Table) Name	Type	Trigger Event ID
ADDRESSES	Iterative	Not applicable (NA)
COMPENSATION	Iterative	NA
COMPENSATION	Retro	COMPENSATI
CONTRACT_DATA	Iterative	NA
EMPLOYMENT	Iterative	NA
GPAU_ABSADV_SEG	Segmentation	AU_ABSADV
GPAU_EE_TAX_DTL	Iterative	NA
GPAU_GARN_DTLS	Iterative	NA
GPAU_LSL_HISTRY	Iterative	NA
GP_ABSEVT_SGPAU	Iterative	NA
GP_ABS_EVENT	Iterative	NA
GP_ABS_EVENT	Retro	GPABSEVENT
GP_ABS_OVRD	Iterative	N/A
GP_ABS_OVRD	Retro	GPABSOVRD
GP_PI_MNL_DATA	Iterative	NA

Record (Table) Name	Type	Trigger Event ID
GP_PI_MNL_DATA	Retro	GPPIMNLDAT
GP_PI_MNL_OSVR	Iterative	NA
GP_PI_MNL_OSVR	Retro	GPPIMNLISOV
GP_PYE_OVRD	Iterative	NA
GP_PYE_OVRD	Retro	GPPYEOVRD
GP_PYE_OVR_SOVR	Iterative	NA
GP_PYE_OVR_SOVR	Retro	GPPYEOVRSO
GP_PYE_SECT_DTL	Iterative	NA
GP_PYE_SECT_DTL	Retro	GPPYESECTD
GP_RTO_TRGR	Iterative	NA
GP_RTO_TRGR_CTRY	Iterative	NA
GP_SEG_TRGR	Iterative	NA
JOB	Iterative	NA
JOB	Retro	JOB
JOB	Segmentation	NA
JOB_JR	Iterative	NA
PERSON	Iterative	NA
PERS_DATA_EFFDT	Iterative	NA
PERS_ORG_INST	Iterative	NA
SCH_ASSIGN	Iterative	NA
SCH_ASSIGN	Retro	SCHASSIGN
SCH_MNG_SCH_TBL	Iterative	NA
TL_PAYABLE_TIME	Iterative	NA
WKF_CNT_TYPE	Iterative	NA

## Segmentation Events

The following is a list of segmentation events for Australia.

Name	Description	Segment Type
AU_ABSADV	Pay Absence in Advance	Period
COMPRATE	Comp Rate Segmentation	Element (Slice)
JOB	Job Segmentation	Period

## Identifying Proration Rules

The Australian extension includes two proration rules in addition to the fourteen rules supplied for all countries. The following table shows the key information about them:

Name	Description	Numerator	Denominator
AUS PO ANNL WRKDYS	Percent of Annual - Workdays	Count GP WORK DAY COUNT	Formula AUS FM PRD WRKDAY
AUS PO ANNL CALDYS	Percent of Annual - Cal Days	Duration GP CAL DAYS SEG	Formula AUS FM PRD CALDAYS

## Identifying Rounding Rules

The Australian extension includes seven rounding rules in addition to the sixty rules supplied for all countries. The following table shows the key information about them. In the last column, *R*, *U*, or *T* indicates:

- *R*: Round up if greater than or equal to the listed value; otherwise, round down.
- *U*: Round up.
- *T*: Truncate down.

Name	Description	Rounding (R) or Increment (I)	Size	R, U, or T
AUS RR RND NR 3DEC	Round Near 3 Decimals	R	03	R 5
AUS RR RND UP 3DEC	Round Up to 3 Decimals	R	03	R 5
AUS RR RND DN 3DEC	Round Down to 3 Decimals	R	03	R 5 or T
AUS RR INC NR 0.05	Increment to Near 5 Cents	I	0.05	R 0.025
AUS RR INC UP 0.05	Increment Up to 5 Cents	I	0.05	R 0.025 or U
AUS RR INC DN 0.05	Increment Down to 5 Cents	I	0.05	R 0.025 or T
AUS RR RND UP 5DEC	Round Up 5 Decimal Places	R	05	U

# 4

## Setting Up for Tax Reporting

### Understanding the Setup for Taxation Calculations

The calculation of tax, using the tax scales, is only a part of managing taxation. You also need to enter details about the pay entity (usually the company or organization), provide the Australian Tax Office (ATO) with tax file number (TFN) information, enter and maintain tax-related information about each employee, and submit statutory reports to the ATO.

#### Related Topics

- [Understanding Taxation Processing](#)  
The Australian country extension to Global Payroll comes with all the elements required to calculate a payee's tax correctly. The system calculates taxes in a variety of situations, such as multiple payments within a calendar period, annualized tax, mid-period hires, retroactive taxation, and terminations.
- [Understanding Retroactive Tax Processing](#)  
Global Payroll for Australia provides payroll rules and elements to calculate taxes on additional payments that are granted retroactively. An additional payment can include a:
- [Understanding Periodic Tax for Leave Payments on Termination](#)  
To calculate periodic tax for leave payments on termination, Global Payroll for Australia averages the earnings over 12 months and then brings the average down to a per period amount by dividing it by the employee's pay period factor (that is, the number of pay periods in a year for the employee). The correct pay period factor for each employee is returned by the formula TAX FM TAX PERIODS (the pay period factor is 12 for employees paid monthly, 52 for employees paid weekly, and so on), and the tax is calculated by the deduction PERIODIC TAX which uses the formula TAX FM PERIODIC to determine the correct tax amount.
- [Understanding Taxable Earnings Accumulators](#)  
There are several taxable earnings accumulators to which you may need to add earning elements that you create yourself to supplement or replace the earnings delivered with Global Payroll for Australia. These are the PD MARGINAL, PD GRS ANNULISED, and PD GRS PERIODIC accumulators. They are used to calculate marginal, annualized, and periodic taxes respectively. When you create a new earning element, you should evaluate it to determine whether it is subject to one of these taxes, and if so, you should add it to appropriate tax accumulator.
- [Entering Information for Tax Processing](#)  
The correct calculation and reporting of tax depends on the employee data that is stored in the system.
- [Submitting the Electronic TFN Declaration](#)  
The output of the GPAU\_TFN\_ELC Application Engine process is a magnetic media file for submission to the ATO.
- [Setting Earnings and Deduction Categories](#)  
The earnings and deductions categories determine where earnings and deductions appear on the payment summary.

- [Collecting FBT-Liable Earnings](#)  
The ATO requires that you report FBT-liable earnings when the gross-up value (of all FBT-liable earnings) exceeds a minimum figure. To have the system calculate the reportable fringe benefits amount for inclusion on the payment summary, you run a collect process.
- [Generating Payment Summary Data](#)  
When data preparation is complete, you can generate the payment summary data for each employee. You can view the data before printing payment summaries for issue to payees.
- [Separating Eligible Termination Payment Data](#)  
If the system detects Lump Sum C ETPs during the Create Payment Summary process, it stores the data separately.

## Entering Information for Reporting Tax

To set up tax reporting, use the Pay Entities AUS (GPAU\_PYENT\_DTL) and Supplier Information AUS (GPAU\_SUPPLIER) components.

Tax reporting varies depending on the information that the system stores about the organization.

This topic lists the pages used to enter information for reporting tax.

### Note

You use the pages discussed in this section to create the following files, which you submit to the ATO: the Group Tax file, the Payment Summaries file, and the TFN declaration.

## Pages Used to Enter Information for Reporting Tax

Page Name	Definition Name	Usage
Pay Entities AUS Page	GPAU_PYENT_EXT	Enter pay entity information that the ATO requires in various reports or electronic files.
<a href="#">Supplier Data Page</a>	GPAU_SPPLR_DATA1	Enter information about the organization submitting the fortnightly TFN declaration. The information entered on this page is included in the electronic file that is generated.
Supplier Address Page	GPAU_SPPLR_DATA2	Enter supplier address information.

## Supplier Data Page

Use the Supplier Data Page page (GPAU\_SPPLR\_DATA1) to enter information about the organization submitting the fortnightly TFN declaration. The information entered on this page is included in the electronic file that is generated.

Navigation:

**Set Up HCM, and then Product Related, and then Global Payroll & Absence Mgmt, and then Taxes, and then Supplier Information AUS**

This example illustrates the Supplier Data page.

Supplier Data

Supplier Address

**TFN Supplier Information**

Pay Entity	KAAUSBI	Australian Business Institute
ABN	95068282166	
ATO Report Specs No	<input type="text"/>	
ATO Gateway User ID	<input type="text"/>	
Registered Agent Number	95068282	
Sending Service Provider	<input type="text"/>	
Registered Name	ADAM MATHEW	
Supplier File Reference	<input type="text"/>	
Email Address	adam.mathew@abc.com	

**Contact Details**

Name	ADAM MATHEW	
Telephone	02 8306 6700	
Phone Extension	<input type="text"/>	
Fax Number	<input type="text"/>	

Field or Control	Description
<b>Registered Agent Number</b>	An external identifier issued by the ATO on behalf of the Tax Agent's Board. It used to uniquely identify an individual who has registered by the Board as a Tax Agent. Existing Component 'GPAU_SUPPLIER' is modified to accommodate the new field 'GPAU_STP_TAN'. It is an optional field. The Registered Agent Number issued by Tax Practitioners Board that is associated with Intermediary ABN.
<b>Sending Service Provider</b>	An entity (including sole trader), directly connected to the ATO, that only provides the technical service for one or multiple employers, registered agents or payroll software providers to deliver payroll reports to the ATO in the correct technical format or through a permitted technical channel. This information is used as part of Declaration Statement in STP Payroll Event File AUS Run Control as required by ATO to authorize Sending Service Provider for lodgement and receive STP Payroll Reports on behalf of Employer.
<b>Income Type</b>	This field determines the income type.

## Review Payroll Tax Rates AUS Page

The mental health and well-being surcharge for employers is a new revenue mechanism introduced by State of Victoria to provide stable and dedicated form of additional funding to aid and strengthen the mental health system.

The mental health and well-being surcharge is applicable for employers as per the conditions mentioned below:

- Any employer paying Victorian taxable wages and has Australian wage above first annual threshold of \$10 million (i.e. monthly threshold of \$833,333) will pay 0.5% of Victorian taxable wages.
- Any employer paying Victorian taxable wages and has Australian wage above second annual threshold of \$100 million (i.e. monthly threshold of \$8,333,333) will pay additional 0.5% of Victorian taxable wages.

Use **State Surcharge Rates** tab in Review Payroll to Review Tax Rates AUS (GPAU\_SPT\_SC\_RT) page.

Navigation:

**Set Up HCM**, and then **Product Related**, and then **Global Payroll & Absence Mgmt**, and then **Taxes**, and then **Review Payroll Tax Rates AUS**

This example illustrates the fields and control of Review Payroll Tax Rates\_State surcharge Rates page.

The screenshot shows the Oracle Review Payroll Tax Rates AUS page. The page title is "Review Payroll Tax Rates AUS". The breadcrumb trail is "Manager Self Service > Review Payroll Tax Rates AUS". The page has two tabs: "State Tax Rates" and "State Surcharge Rates", with the latter being active. The state is set to "Victoria".

Under "State Status", the effective date is "07/01/2022" and the status is "Active".

Under "State Surcharge Payment Frequency", the frequency is "Monthly".

The "State Surcharge Rates" section contains a table with the following data:

Min Threshold Amt	Max Threshold Amt	Min Adjusted Threshold Amt	Max Adjusted Threshold Amt	Surcharge %
0.00	833333.32			0.000
833333.33	833333.32			0.500
833333.33	9999999999.99			1.000

Field or Control	Description
<b>State</b>	Name of the Australian state.
<b>Effective date</b>	Date from when this is effective.
<b>Status</b>	Status set to active or inactive.
<b>Min Threshold Amt</b>	Standard minimum monthly and yearly legislative threshold value
<b>Max Threshold Amt</b>	Standard maximum monthly and yearly legislative threshold value.
<b>Min Adjusted Threshold Amt</b>	Populated using a DMS Script for adjusted minimum monthly and yearly threshold value (if required)
<b>Max Adjusted Threshold Amt</b>	Populated using a DMS Script for adjusted maximum monthly and yearly threshold value (if required).
<b>Surcharge %</b>	Surcharge percentage.

## Viewing Tax Scales

The PeopleSoft system provides several pages that display tax scales and rates.

This topic lists the pages used to view tax scales.

### Pages Used to View Tax Scales

Page Name	Definition Name	Usage
Family Tax Benefit Rates Page	GPAU_FTB_RATE	View the FTB rate for each pay frequency.
HELP Rates Page	GPAU_HECS_RATE	View the HELP rate applicable to each weekly earnings.
SFSS Rates Page	GPAU_SFSS_RATE	View the SFSS rate applicable to each weekly earnings.
Tax Scales Page	GPAU_TAX_SCALES1	View the tax percentage or amount for each weekly earnings amount for each tax scale.
Medicare Levy Page	GPAU_TAX_SCALES2	View the Medicare levy adjustment details. The adjustments apply to tax scales 2, 6, and 7 only.

# 5

## Setting Up State Payroll Tax Reporting

### Identifying Data for State Payroll Tax Reporting

Before you begin configuring Global Payroll to report payroll tax, you need to identify the earnings, deductions, benefits, and expenses that are subject to payroll tax. To do this, check with the state revenue office of each state in which the organization pays employees. After you have gathered this information, run the payroll routinely and process payroll tax.

### Setting Up Group Pay Entities

To set up group pay entities, use the Group Pay Entities AUS (GPAU\_GRP\_ENT) component.

The various state revenue offices define group pay entities to prevent parent and subsidiary organizations from avoiding payroll tax by splitting. The PeopleSoft system does not determine groupings or membership of pay entities in groups. Some members of the group might be administered outside the PeopleSoft system.

To calculate payroll tax, you must define at least one group and make all appropriate pay entities members of that group—even if the organization consists of only a single pay entity.

Payroll tax has a deduction threshold that is payable if taxable earnings don't exceed the specified amounts in each state. Only one pay entity within a group can claim this deduction. You can, however, have the threshold apportioned equally between all the pay entities within the group that you define.

You create the mandatory State Payroll report by running by the Group Pay Entity process.

When you create a group pay entity, you select from the existing pay entities. The pay entity that becomes the group entity is a member of its own group.

This topic discusses how to group pay entities.

### Page Used to Set Up Group Pay Entities

Page Name	Definition Name	Usage
<a href="#">Group Pay Entities AUS Page</a>	GPAU_GRP_ENT	Consolidate pay entities in a group pay entity; apportion the deduction threshold across all pay entities or designate one pay entity for the threshold.

### Group Pay Entities AUS Page

Use the Group Pay Entities AUS page (GPAU\_GRP\_ENT) to consolidate pay entities in a group pay entity; apportion the deduction threshold across all pay entities or designate one pay entity for the threshold.

Navigation:

**Set Up HCM**, and then **Product Related**, and then **Global Payroll & Absence Mgmt**, and then **Taxes**, and then **Group Pay Entities AUS**, and then **Group Pay Entities AUS**

This example illustrates the fields and controls on the Group Pay Entities AUS page. You can find definitions for the fields and controls later on this page.

Field or Control	Description
<b>Apportion Deductions</b>	Select to have the whole deduction threshold apportioned equally across all group members. If the <b>Apportion Deductions</b> check box is selected and there is no designated company for the threshold deduction, the system apportions the threshold deduction across all the states of each company.

**Group Pay Entities**

Field or Control	Description
<b>Pay Entity</b>	Add the members of the group.
<b>Designated SPT Pay Entity</b>	Select one of the pay entities to receive the full deduction threshold. You can leave them all cleared and have the threshold apportioned equally between all members by selecting the <b>Apportion Deductions</b> check box. After you designate an SPT pay entity, the system deselects the <b>Apportion Deductions</b> check box (if it was selected) and makes it display-only.

## Maintaining and Viewing Payroll Tax Tables

To set up payroll tax data, use the Payroll Tax Elements AUS (GPAU\_SPT\_TAX\_RATE) component.

Because each organization's earnings, benefits, deductions, and expenses can differ, the organization controls this information. Before you can accurately report on payroll tax liabilities for the organization, you need to enter various elements into the payroll tax rates tables.

This topic lists the pages used to maintain and view payroll tax data.

## Pages Used to Maintain and View Payroll Tax Data

Page Name	Definition Name	Usage
Trainee Rebate Page	GPAU_SPT_REBATE	Reduce the payroll tax liability by the value of the rebates applicable to payees who are trainees or apprentices. Enter the amount of the rebate that you have calculated for each trainee or apprentice. The record is effective-dated, so you can set it to 0.00 when it no longer applies.
Non Tax Earnings Page	GPAU_SPT_ERNS	Enter nontaxable earnings by state. Some earnings, such as those that you defined for expense reimbursement, are typically not subject to payroll tax. Earnings not entered in this page are included in the tax calculation.
Taxable Deductions Page	GPAU_SPT_DEDS	Enter taxable deductions by state. You need to identify benefits or deductions that are subject to payroll tax and enter them for inclusion in the SPT calculation. Identify deductions that are subject to FBT, upon which SPT is also payable.
Non Tax Deduction Page	GPAU_SPT_NTXDED	Enter nontaxable deductions by state.
Taxable Expenses Page	GPAU_SPT_EXPN	Enter taxable expenses by state. Typically, these expenses are part of salary packaging.
State Tax Rates Page	GPAU_SPT_TAX_RATE	View the various limits, threshold percentages and amounts, multipliers, and divisors.

# 6

## Managing Single Touch Payroll (STP)

### Understanding Single Touch Payroll (STP)

Single Touch Payroll is an initiative introduced by the Australian government to simplify the tax reporting process for employers. Employers are required to electronically report payroll and superannuation information to the ATO (Australian Tax Office ) as and when employees are paid, rather than reporting in separate periods throughout the year or at the end of the year. In addition, it also streamlines tax file number (TFN) declarations and Super Choice forms by providing a digital channel to simplify the process of employing new employees.

#### Pay Event

In PeopleSoft, a Pay Event is created as and when an employee is paid. It shows the amount that is paid to employees for the services they have done for the organization within a certain period. It is the combination of the financial records of their employees' salaries, wages, allowances and deductions. Pay Event data consist of both employer and individual employee data:

1. PAYEVNT - Summary Report which helps the Employer, Tax Agent or Business Representative to notify ATO for the payments made to their employees along with related Tax and Super obligations validated and processed by SBR.
2. PAYEVNTEMP - Detail Report which helps the Employer, Tax Agent or Business Representative to notify ATO for the payments made to an individual employees along with related Tax and Super obligations that is validated and processed by SBR.

This pay event data is electronically reported to the ATO using Single Touch Payroll.

This diagram illustrates the Single Touch Payroll Process Flow.

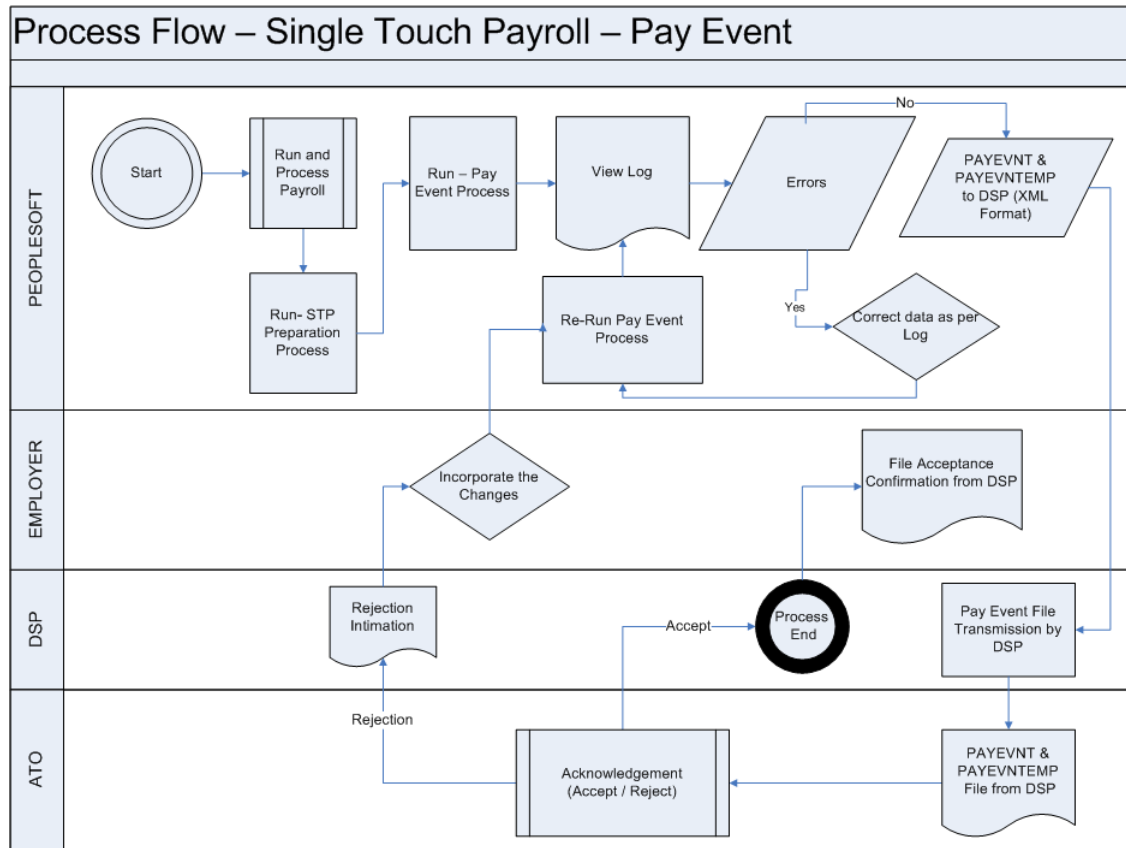

Single Touch Payroll Preparation process derives the Payroll data with the help of Report data and STP Category setup and updates the final results in the respective staging tables as defined in the configuration. Using the XML framework XML reports are generated, when you run the STP Pay Event process. These reports are transferred to ATO and on receiving positive acknowledgment from ATO the process is considered as complete.

If there is any error, you can correct the data and re run the pay event process. If the file is rejected by ATO, Rejection Intimation is passed on to the employer to make required changes and re run the pay event.

### **Note**

PeopleSoft only supports the generation of the XML files and are dependent on 3rd part DataService Providers (DSPs) to handle submission.

### **Related Topics**

- [Setting Up Single Touch Payroll \(STP\)](#)  
Single Touch Payroll is an initiative by the Federal government where the Employers are required to report payroll and superannuation information electronically to the ATO as and when employees are paid.
- [Generating Pay Event File](#)  
This section provides an overview of Pay Event File file and discusses how to create a Pay Event file.

## Setting Up Single Touch Payroll (STP)

Single Touch Payroll is an initiative by the Federal government where the Employers are required to report payroll and superannuation information electronically to the ATO as and when employees are paid.

This topic discusses on how to set up Single Touch Payroll in PeopleSoft as an employer.

### Pages Used to Set Up Single Touch Payroll (STP)

Page Name	Definition Name	Usage
<a href="#">Supplier Data Page</a>	GPAU_SPPLR_DATA1	Enter information about the organization submitting the fortnightly TFN declaration. The information entered on this page is included in the electronic file that is generated.
<a href="#">STP Category Setup AUS Page</a>	GPAU_STP_CAT	Map the Tuple and Facts along with respective EOY or STP VR Category for extracting data during STP Pre Process for Pay Event Reporting.
<a href="#">STP SOVR Setup</a>	GPAU_STP_SOVRCAT	Add STP SOVR category.
PeopleSoft Absence Management: Define Report Data Page	GP_RPT_TBL	Assign the output table, writable array, primary input table type, and segment options.
Application Fundamentals: XML Set Table Page	XML_SET_TBL	Maintain XML set definitions.
Application Fundamentals: Node Table Page	XML_NODE_TBL1	Define the nodes that comprise the XML file structure for your country-specific functionality.
Application Fundamentals: XML Template Page	XML_TEMPLATE	Define templates for use during XML file generation.
Application Fundamentals: XML Tester Page	XML_RC_TESTER	Allow running any XML file defined using previous setup, so that the user can validate if the resultant report is the expected one.

#### Setting Up Single Touch Payroll

To set up Single Touch Payroll (STP):

- Ensure that Supplier Data meets the latest ATO requirements. Prior to submission of STP Pay Event Files, employer must register and work with their account manager to meet the reporting requirement as initiated by ATO and to adhere the compliance. For more information, see [Supplier Data Page](#)
- Map the Employee category with required sub categories and define the SOVR category and SOVR variable that needs to be considered for reporting. Map the Tuple and Facts along with respective EOY or STP VR Category for extracting data during STP Pre Process for Pay Event Reporting. For information, see [STP Category Setup AUS Page](#).

- Assign the output table, primary input table type, and segment options using the Define Report Data page. Report data takes the list of PIN Numbers from the SOVR categories defined in STP Category Setup page, and returns the list of Accumulators required for reporting. STP Preparation process derives the Payroll data based on Report data and STP Category setup. The final results are updated in the respective staging tables as defined in the configuration. For more information, see PeopleSoft Absence Management: Defining Report Data
- Configure the XML Framework:
  1. **XML Set Table page:** XML set is to define all the Records and the SQL Views used in the Nodes for reporting values in XML. For more information, see Application Fundamentals: XML Set Table Page
  2. **XML Node Table page:** Node is to define the Tuple and Fact of XML in a configurable way. Simple Node is the last child, which has a value defined in it to report. XML Fact is the simple node. Complex node has a list of Simple nodes associated to it. Root Node is the start of the XML, which is in turn a Complex Node. For more information, see Application Fundamentals: Node Table Page
  3. **XML Template page:** Template created to associate each nodes with the key field combination to give the complete XML structure in the report. For more information, see Application Fundamentals: XML Template Page
  4. **XML Tester page:** Use XML tester to test the generated XML, which generate from above mentioned setup. For more information, see Application Fundamentals: XML Tester Page

## STP Category Setup AUS Page

Use the STP Category Setup AUS page (GPAU\_STP\_CAT) to map between XML Tuple with Category and XML Fact with Sub Category. SOVR Variable determines, the Variable that assigned in the Earnings to determine the SOVR category and the Supplementary Element Override. The setup uses the EOY VR CATEGORY (existing one which is used for generating the Payment Summaries), and STP VR CATEGORY (this is a new variable created to map against respective earnings/deductions) required for STP file generation and reporting.

Navigation:

**Set Up HCM**, and then **Product Related**, and then **Global Payroll & Absence Mgmt**, and then **Reports**, and then **STP Category Setup AUS**

The STP Category setup AUS page sets the mapping between XML Tuple with Category and XML Fact with Subcategory.

This example illustrates the fields and controls on the STP Category Setup AUS page.

**STP Category Setup AUS**

Category ALLOWANCE  
Description Allowance

STP Category  
\*Effective Date 01/01/2022  
Record (Table) Name GPAU\_STP\_ALLOW  
 Report PTD  Report YTD  Iterative

STP Sub-Category  
\*Sub-Category AD  
Description Award Transport Payments  
YTD Field Name GPAU\_STP\_AMOUNT

SOVR Category

Seq Nbr	SOVR Variable	SOVR Category	Sign
1	10 STP VR CATEGORY	TRA	Add

Save Return to Search Previous in List Next in List Add Update/Display Include History Correct History

**Field or Control**

**Description**

**Effective Date**

Mapping should be modified to the actual migration date along with the effective date of STP Category setup. Income Type field mapping is mandatory with the latest effective date in the STP Category setup for addition of new income types like CHP and SWP.

**Record (Table) Name**

Select the Staging Record where the data to be stored for reporting while running STP Preparation Process. This field is to define the Staging table record where the data to be stored for final reporting.

**Report PTD**

Select the check box if PTDs are required under the specified Category and Sub-Category. This enables PTD field name where we can define the Field of the staging table defined under Record Name. The PTD value calculated update in the respective field defined.

**Report YTD**

Select the check box if YTDs are required under the specified Category and Sub-Category. This enables YTD field name where we can define the Field of the staging table defined under Record Name. The YTD value calculated update in the respective field defined.

**SOVR Variable**

Select the variable that is assigned in the Earnings. This determine the SOVR category and the Supplementary Element Override. The SOVR Variable are either EOY VR Category or STP VR Category.

Field or Control	Description
<b>SOVR Category</b>	Select the respective EOY VR or STP VR Category corresponding to those earnings and deductions that is required for each facts of that Tuple. This determines the actual SOVR categories that contribute to the Sub-Category, which is the Final amount to display in the report.

**Note**

This setup is pre-seeded as system data and employer can make necessary changes to set up additional categories as part of STP Reporting.

**STP Income Type Field Mapping**

STP Income Type Field Mapping is to draw between fields for Gross, Tax, CDEP, EFEI between GPAU\_STP\_PAYSTG and GPAU\_STP\_PAYTBL to convert payroll data stored in Phase 1 staging record into Phase 2 format of reporting. This transition is from horizontal to vertical data.

In Phase 2, Gross, tax, bonus and commissions, directors' fee, overtime payments, CDEP, EFEI are still stored in PS\_GPAU\_STP\_PAYSTG but data is converted and stored in PS\_GPAU\_STP\_PAYTBL to make it compatible with the latest format. This conversion is done with the below setup.

This example illustrates the fields and controls on the STP Category Setup AUS\_STP Income Type Field Mapping page.

**STP Category Setup AUS**

Category ALLOWANCE  
 Description

**Record Field Mapping** 1 of 1 | View All

Effective Date  
 Income Type

Target Record  
 Source Record

	Target Field	Source Field	
1	<input type="text"/> <input type="button" value="Q"/>	<input type="text"/> <input type="button" value="Q"/>	<input type="button" value="+"/> <input type="button" value="-"/>

Field or Control	Description
<b>Target Record</b>	This field is to define the Staging table record of Phase 2.
<b>Source Record</b>	This field is to define the Staging table record of Phase 1.
<b>Income Type</b>	This field determines the income type.

## STP SOVR Setup

PeopleSoft delivers pre-seeded STP SOVR values that will be displayed in the STP Category Setup AUS page. However, if you want to create a new SOVR value, then you can make use of the GPAU\_STP\_SOVRCAT component.

Use SOVR Mapping (GPAU\_STP\_SOVRCAT) page to add SOVR category.

Navigation:

**Set Up HCM**, and then **Product Related**, and then **Global Payroll & Absence Mgmt**, and then **Reports**, and then **STP SOVR Setup AUS**

This example illustrates fields and controls of STP SOVR Setup AUS Page.

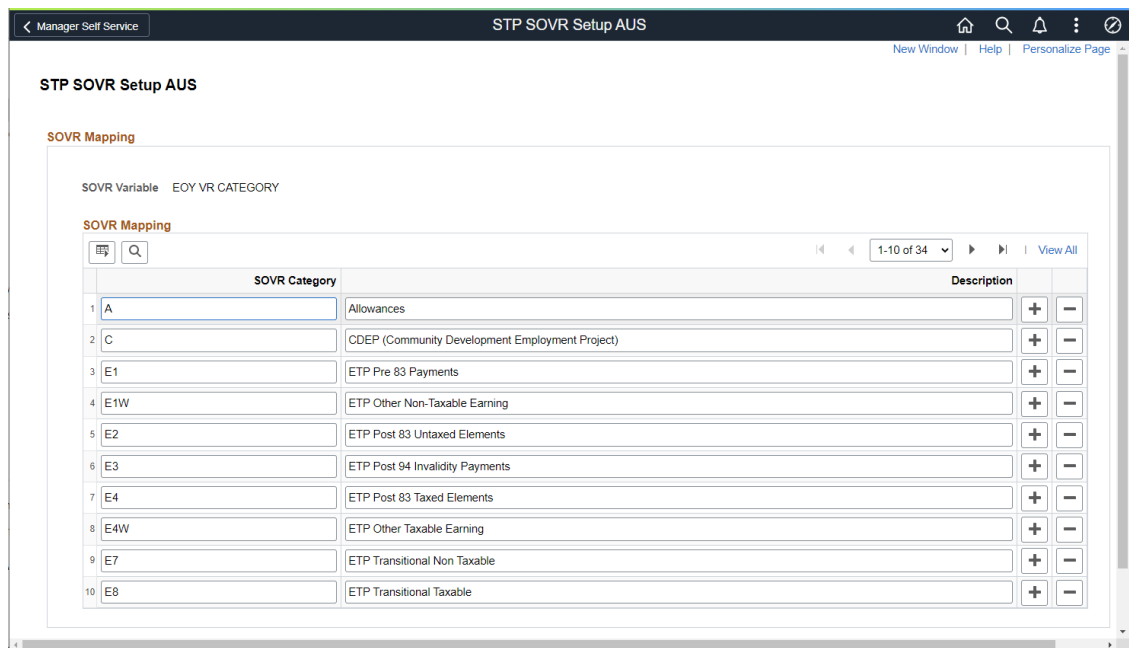

Use the “+” button to add a new SOVR category.

Map the STP VR CATEGORY “FA” against the respective earning elements with an effective date under the tab Supporting Element Override. Users need to ensure the mapping of the respective SOVR to the correct Earnings and Deductions to report under the correct categories of STP.

**Note**

Ensure the mapping of the respective SOVR to the correct **Earnings** and **Deductions** to report under the correct categories of STP as per ATO definitions.

Employee's year to date payroll results is reported in Single Touch Payroll Pay Event file. Year to date accumulators is contributed by the respective earnings and deductions that are processed in payroll. Each earnings and deductions are assigned with SOVR category in the supporting element override tab as shown above with the help of a variable EOY VR CATEGORY.

These SOVR categories are used to retrieve the list of accumulators for Payment Summary (PSM) reporting in Global Payroll Australia and the same approach is used for STP reporting. Some of earnings and deductions which do not have the SOVR category will be assigned a new category with an element type as variable STP VR CATEGORY or STP VR P2 CATEGORY which are specific to STP instead of existing variable EOY VR CATEGORY so that there will not be any impact on existing PSM reporting and also to make sure if the users are using the feature for any other kind of reconciliation.

New SOVR Category under the variable STP VR CATEGORY is added in order to classify allowance type as others with description "First Aid Allowance" under STP Category Setup, under Category "Allowance".

The example illustrates STP Category Setup AUS with Allowance category.

**STP Category Setup AUS**

Category ALLOWANCE  
Description Allowance

STP Category

\*Effective Date 01/01/2022  
Record (Table) Name GPAU\_STP\_ALLOW  
 Report PTD  Report YTD  Iterative

STP Sub-Category

\*Sub-Category AD  
Description Award Transport Payments  
YTD Field Name GPAU\_STP\_AMOUNT

SOVR Category

Seq Nbr	SOVR Variable	SOVR Category	Sign
1	STP VR CATEGORY	TRA	Add

Save Return to Search Previous in List Next in List Add Update/Display Include History Correct History

This example illustrates the STP Category Setup AUS page

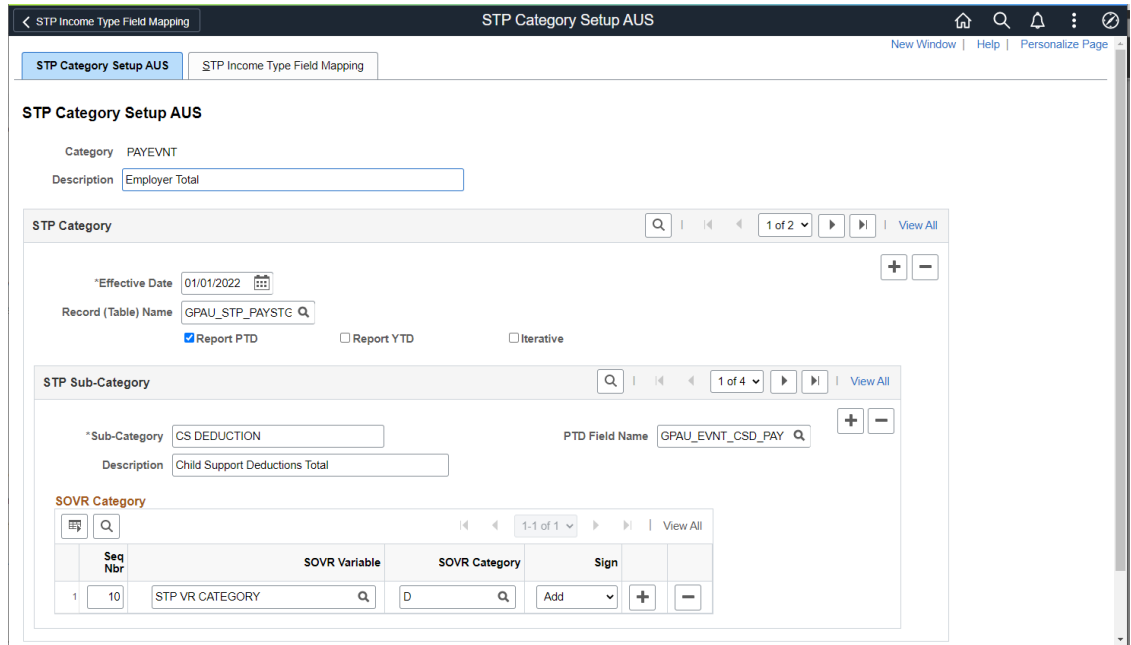

The STP Category setup AUS page sets the mapping between XML Tuple with Category and XML Fact with Subcategory.

This example illustrates the XML mapping with the respective fields in the STP Category Setup AUS page.

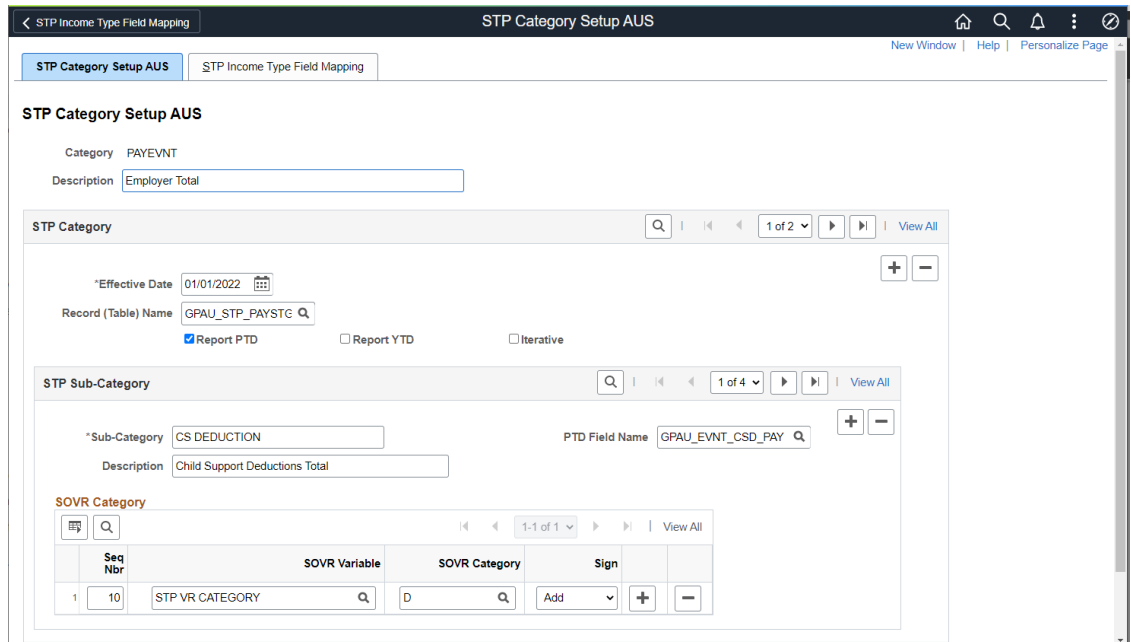

Field or Control	Description
<b>Effective Date</b>	If the customer plans to migrate to STP Phase 2 anytime later than 01-Jan-2022, effective date of the STP Income Type Field mapping should be modified to the actual migration date along with the effective date of STP Category setup. Income Type field mapping is mandatory with the latest effective date in the STP Category setup for addition of new income types like CHP and SWP.
<b>Record Name</b>	Define the Staging table record where the data to be stored for final reporting.
<b>Report PTD</b>	This field determines if PTDs are required under the specified Category and Sub-Category. This enables PTD field name where we can define the Field of the staging table defined under Record Name. The PTD value calculated update in the respective field defined.
<b>SOVR Category</b>	Select the respective EOY VR or STP VR Category corresponding to those earnings and deductions that is required for each facts of that Tuple. This determines the actual SOVR categories that contribute to the Sub-Category, which is the Final amount to display in the report.

 **Note**

This setup is pre-seeded as system data and employer can make necessary changes to set up additional categories as part of STP Reporting.

In Phase 1, payroll related information is stored in PS\_GPAU\_STP\_PAYSTG along with allowances in PS\_GPAU\_STP\_ALLOW, deduction in PS\_GPAU\_STP\_DED, employee termination payments in PS\_GPAU\_STP\_ETP

In Phase 2, PS\_GPAU\_STP\_PAYSTG is split into below records:

Field or Control	Description
<b>PS_GPAU_STP_PAYTBL</b>	Gross, tax, bonus and commissions, directors' fee, overtime payments, CDEP and EFEI.
<b>PS_GPAU_STP_PAIDL</b>	Paid Leaves
<b>PS_GPAU_STP_LUMPSM</b>	Lump sum payments
<b>PS_GPAU_STP_SS</b>	Salary Sacrifice
<b>PS_GPAU_STP_SUP</b>	Super Entitlements
<b>PS_GPAU_STP_RFB</b>	Reportable Fringe Benefits

### Field Mapping

The STP Income Type Field Mapping is to draw between fields for Gross, Tax, CDEP, EFEI between GPAU\_STP\_PAYSTG and GPAU\_STP\_PAYTBL in order to convert payroll data stored in Phase 1 staging record into Phase 2 format of reporting.

In Phase 2, Gross, Tax, Bonus and Commissions, Directors' Fee, Overtime payments, CDEP, EFEI are still stored in PS\_GPAU\_STP\_PAYSTG but data is converted and stored in the new record PS\_GPAU\_STP\_PAYTBL to make it compatible with the latest format.

This example illustrates the STP Category Setup AUS page.

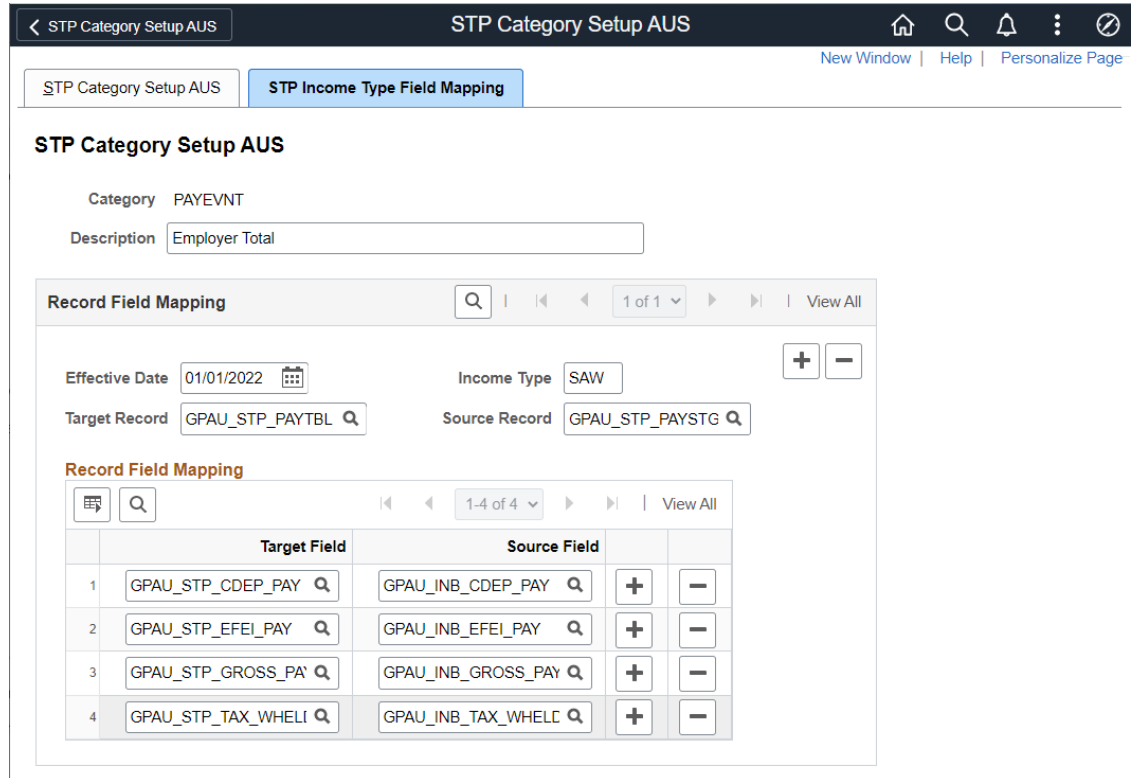

Field or Control	Description
<b>Target Record</b>	This field is to define the Staging table record of Phase 2.
<b>Source Record</b>	This field is to define the Staging table record of Phase 1.
<b>Income Type</b>	This field determines the income type.

Separate Source Fields are made available for users to capture these other income types as part of the solution. Users will need to appropriately map these Source Fields to the Target Fields.

**Note**

Users need to do the setup for any non-delivered Income Type using STP Category setup page. In addition, appropriate mapping of Source and Target fields will be required.

# STP Reconciliation Setup AUS

STP Reconciliation Setup AUS is configured with the Earnings/Deductions contributing to the sub-category and the various collections reported in the STP file.

Employee can map any customized Earnings/Deductions used instead of the PeopleSoft delivered Earnings/Deductions that are being reported in STP. This setup is delivered as a system data as part of the Reconciliation solution.

Navigation:

**Set Up HCM**, and then **Product Related**, and then **Global Payroll & Absence Mgmt**, and then **Reports**, and then **STP Reconciliation Setup AUS**

This example illustrates the fields and controls of STP Reconciliation Setup AUS page.

Field or Control	Description
<b>Effective Date</b>	The date from which the setup is valid.
<b>Collection Name</b>	The name of the Tuple that are being used for reporting.
<b>Sequence</b>	The Sequence Order of the Field on the report.
<b>Sub-Category</b>	The name of the facts that are being used for reporting under the respective Tuple.
<b>Description</b>	The description of the sub-category.
<b>Sign</b>	The values are: <ul style="list-style-type: none"> <li><b>Add</b> - Specify whether the corresponding field adds to the collection total.</li> <li><b>Subtract</b> - Specify whether the corresponding field deducts from the collection total.</li> </ul>

Field or Control	Description
Element Type	Displays the Element Type. Values can be: <ul style="list-style-type: none"> <li>Earning</li> <li>Deduction</li> </ul>

### Run Control Parameters

Run the Run Control process by **Pay Entity, Group List, Streams, Pay Group, Period End Date** or individual Employee ID similar to that of the STP Preparation process with an additional input of **STP Report Type**. Upon the selection of the appropriate options, few fields will be enabled or disabled based on the run control parameters chosen. The **Tax Year, Pay Entity and Calendar ID** or **Period End Date** are the mandatory required fields for all types of processing options.

Field or Control	Description
<b>STP Report</b>	Select the required report type from the following options: <ul style="list-style-type: none"> <li>All</li> <li>Pay Event Employer</li> <li>Pay Event Employee</li> </ul>
<b>Tax Year</b>	The year for which tax year this Payroll Event Reconciliation (Pay Event Employer & Pay Event Employee) needs to be processed.
<b>Pay Entity</b>	The Pay Entity for which data should extracted. Define the pay entity for which the employer would like to include the payroll data for Payroll Event Reconciliation (Pay Event Employer & Pay Event Employee).
<b>Calendar Group ID</b>	Input the Calendar Group ID for which the employer considers the payroll results for Payroll Event Reconciliation (Pay Event Employer & Pay Event Employee).
<b>Employee ID &amp; BAL GRP</b>	If the process run only for one employee, then <b>Processing Option</b> should be set to Employee ID and the Employee ID should be entered in the relevant field.
<b>Group List</b>	If the process run for a group of employees, then <b>Processing Option</b> should set to Group List and the Group List ID should enter in the relevant field.
<b>Streams</b>	If the process run for a given payroll stream, then <b>Processing Option</b> should be set to Streams and the Stream Number should enter in the relevant field.
<b>Period End Date</b>	Select the option as <b>Period End Date</b> to run the process for a list of CAL_RUN_IDs having the same <b>Period End Date</b> . On selecting this option, two fields, <b>Period End Date</b> and <b>Period ID</b> are displayed.
<b>Show EEs with Difference Only</b>	Select for the report to contain only the employees with differences. Keep it unchecked to include all the employees in the report. By default, this is selected.

Field or Control	Description
<b>Consider STP Payee Override</b>	Select for the report to include the Payee Override entered. By default, this is not selected.
<b>Sub-Category Filters</b>	Enables if the STP Report is not <b>ALL</b> , for report to contain only the selected sub-category against Pay Event Employer or Employee, Select the respective sub-category from the filters. By default, this is selected for <b>STP Report Pay Event Employer</b> and <b>Pay Event Employees</b> .

### Related Topics

- [Understanding Single Touch Payroll \(STP\)](#)  
Single Touch Payroll is an initiative introduced by the Australian government to simplify the tax reporting process for employers. Employers are required to electronically report payroll and superannuation information to the ATO (Australian Tax Office ) as and when employees are paid, rather than reporting in separate periods throughout the year or at the end of the year. In addition, it also streamlines tax file number (TFN) declarations and Super Choice forms by providing a digital channel to simplify the process of employing new employees.

## Single Touch Payroll - Phase 2

A legislative instrument issued by the Australian Taxation Office (ATO) on 03 February 2021 has confirmed that the commencement date for mandatory Single Touch Payroll Phase 2 reporting will start from 01 January 2022 — a six-month extension from the previously proposed 01 July 2021 start date.

The Single Touch Payroll Phase 2 aims to simplify the reporting obligations for the payer and payee so that consolidated reporting removes the need for manual reporting to other government agencies. Australian Tax Office is changing reporting requirements to better assist employees while completing Individual Income Tax Returns, and income-tested payments are accurately calculated when taking into consideration employee earnings for the financial year.

The biggest change is in the aspect of reporting obligations. By introducing new cessation types, it replaces majority of DHS (Department of Human Services) employment separation certificate forms. Payers are not required to provide separate reports to the Child Support Registrar each month. Payers can voluntarily report child support.

For more details, refer Single Touch Payroll Phase 2 details on the [ATO website](#).

### Transitioning to STP Phase 2

A payer can transition from the pay event 2018 to the pay event 2020 service at any time throughout the financial year. Once the payer transitions to and begins reporting through the pay event 2020 service, then the payer must report in-line with the rules of this Business Implementation Guide. A payer must report by income stream collection and provide the employment conditions.

Unlike the initial phase of Single Touch Payroll, phase 2 addresses the interaction between the old and new data, functionality, and design. Many aspects of the reporting have been introduced to meet the needs of Services Australia, which relies on the accuracy and frequency of the granular reporting of income to streamline their welfare payments processes.

The entire financial year data must be present for the key identifiers of ABN, Branch, BMS Id and Payroll Id when YTD data is being reported during the mid-year Go Live.

This steps provide direct mapping between the PAYEVNT.2018 elements and the PAYEVNT.2020 elements:

- Where a field is not included in the PAYEVNT.2020 service it is marked as REMOVED.
- Where a field is new for PAYEVNT.2020 it is identified as NEW.
- Some fields that are the same have enhanced guidance that may have an impact. These are identified as ENHANCED.
- Some fields from PAYEVNT.2018 may be mapped to a specific field in PAYEVNT.2020, but the Income Stream Collection depends on what and how those payments for income types are in their PAYEVNT.2018 solutions. These fields are marked as DEPENDENT.
- Where one PAYEVNT.2018 field splits into more than one PAYEVNT.2020 field, the decision points are referenced by using references to the PAYEVNT.2018 code label as (2018#999) where 999 represents the number of the label. For example, (2018#47) refers to PAYEVNTEMP47 Payee Gross Payments and the new field is referenced only by its field label. Another example is that (#7) refers to PAYEVNTEMP7 Allowance Type Code. This reference indicates that allowances that were formerly reported under the aggregated gross are now to be separately itemised as specific allowances.
- Where a field can only apply to a specific or range of income types, it is referenced as = xxx, where xxx refers to Income Stream Collections.
- Where the enumerations have changed, the mapping from old value to new value is included in the mapping comments.

### Disaggregation of Gross

The Single Touch Payroll Phase 2 introduces the requirement to report a gross amount for each income type as a disaggregated, or separately itemised, amount. Rather than focus on the Income Tax Return (ITR) classification of assessable income, the data that is to be reported in STP Phase 2 is more aligned to the way the different payment types are categorised in the payroll systems. This change is required to ensure the flexibility of the data use for the future and the full visibility of income for Services Australia to assess, given the different definitions used to determine welfare benefits. Disaggregation of gross provides the granularity to support improving the application of employment income and streamlining claims processes. This improves the accuracy of payments, ensuring individuals receive the right payment at the right time. Gross Amount is the residual amount remaining of the Aggregated Gross YTD after all the other itemised elements have been discretely reported.

#### Note

PAYEVNT.2020 consists of PAYEVNT (Parent) & PAYEVNTEMP (Child). Payer Total Gross Payments Amount (PAYEVNT22) facts under Payer Period Totals Tuple remains the same of what is being reported under STP Phase 1. Gross Amount (PAYEVNTEMP258) reported under Income Stream Collection (PAYEVNTEMP256) must be reported per income type and by country code. If a payee has received more than one income type in the financial year, or more than one country code for relevant income types, then all Income Stream Collections must be reported each time the payee is included in the payroll for payments subject to withholding. The definition of reportable remuneration has not changed, only the reporting of it has changed.

## Income Type and Country Code

Pay Event 2020 services has moved to a framework where the Payment Types (labels) are grouped by Income Type and, for some income types, by Country Code. This is known as the Income Stream Collection.

An inbound assignee who is seconded to work in Australia for an Australian entity but is employed by an offshore entity and is paid, in whole or part of their base salary and other remuneration, by an offshore entity. As the work performed in Australia may be subject to payroll taxes, superannuation guarantee and PAYGW, but not wholly paid by the Australian entity, the income must be reported by Country Code of the offshore entity (home country). The following payment types are permissible for the income types of IAA: PAYGW, Gross, Paid Leave, Allowance, Overtime, Bonus and Commission, Directors Fees, Salary Sacrifice, Lump Sum and ETP.

IAA employees are identified by giving supporting element override of 'I' value against the variable AUS VR FRGN TYPE. Since the processing of this employee is same as the other normal employees (SAW), same elements are used for reporting.

For specific income types such as Foreign Employment, inbound assignees to Australia and Working Holiday Maker country code are mandatory whereas for other income types it is assumed as AU. To report the country code for these income types, the solution is driven through Supporting Element Override (SOVR) using the variable AUS VR STP CTRY CD.

### Note

The Character Value selected in the Supporting Element page a 3 character code. The output file (XML file) prints only the 2 character country code.

## Child Support Deductions and Garnishees

Payers who have child support withholding obligations provide monthly reports to the Child Support Program in Services Australia who in turn detail the withholdings made for each payee over the previous month.

Currently, an employer must submit a deduction report to the relevant child support agency when they deduct the child support from an employee's payment.

The inclusion of child support reporting in Single Touch Payroll (STP) works towards reducing the reporting burden placed on payers. A payer's obligations are satisfied when payment of the child support garnishee amount is received by the Child Support Registrar, not when the amount is reported. The child support amounts reported by the payer using STP are used by Child Support to reconcile the payer's child support record when payment of reported amounts is received from the payer.

Child Support Garnishee & Deduction amounts processed via STP Phase 2 allows employers to report for both the Parent record (Employer / Financial Period to Date Amount / FPTDA) and the Child record (Employee / Financial Year to Date Amount, FYTDA).

Child Support amounts consist of 3 different types:

- Child Support Deductions
- Child Support Garnishees

- Voluntary Child Support (This is Out of Scope for STP Reporting)

Payers' may voluntarily choose to report their child support amounts via STP PAYEVNT 2020 Services. Payers' may elect to commence reporting child support amounts upon/after transitioning to STP PAYEVNT 2020 Services. Payers may choose to move from STP PAYEVNT 2018 Services to STP PAYEVNT2020 Services to be able to report child support amounts.

## Salary Sacrifice

Salary sacrifice is an agreement between employer and employee that allows the employee to forego some part of their salary in exchange for other benefits.

The primary benefit used in salary sacrifice is the superannuation fund (or 'super') which is Australia's pension program.

The minimum mandatory employer contribution to super is 10.00% of wages, which is known as the super guarantee, and that portion is taxed to the employee at only 15%, much less than income tax rates. A salary sacrifice arrangement will permit employee to shift an additional part of their monthly salary into the superannuation fund, which can reduce taxes and provide greater savings for retirement.

The values permissible for the salary sacrifice type (PAYEVNTEMP266) are:

- Superannuation (S) – an effective salary sacrifice arrangement, entered before the work is performed, where contributions are paid to a complying fund, where the sacrificed salary is permanently foregone
- Other Employee Benefits (O) – an effective salary sacrifice arrangement, entered before the work is performed, for benefits other than for superannuation, where the sacrificed salary is permanently foregone.

Salary sacrifice contributions can no longer:

- be used to reduce ordinary time earnings.
- count towards minimum superannuation guarantee obligations.

For the PAYEVNT.2020, this means that if employees were formerly (PAYEVNT.2018) not included in the report, as 100% of their payments were sacrificed, including sacrifice to superannuation, those employees must now be reported. For example, if an employee had reportable payments of 50,000 and 30,000 was sacrificed to superannuation and 20,000 was sacrificed to other employee benefits, resulting in taxable gross of zero, this employee may have previously been excluded but must now be reported.

**Note**

PAYEVNT.2020 consist of PAYEVNT (Parent) & PAYEVNTEMP (Child). The Payer Total Gross Payments Amount (PAYEVNT22) facts under Payer Period Totals Tuple remains the same of what is being reported under STP Phase 1. Whereas Gross Amount (PAYEVNTEMP258) reported under Income Stream Collection (PAYEVNTEMP256) must be reported per income type and country code without reducing the salary sacrifice amount.

PAYEVNT.2020 consist of PAYEVNT (Parent) & PAYEVNTEMP (Child). Please note that Payer Total Gross Payments Amount (PAYEVNT22) facts under Payer Period Totals Tuple remains the same of what is being reported under STP Phase 1. Whereas Gross Amount (PAYEVNTEMP258) reported under Income Stream Collection (PAYEVNTEMP256) must be reported per income type and country code without reducing the salary sacrifice amount.

## Lump Sum Payments

A lump-sum payment is often a large sum that is paid in one single payment instead of breaking it up into instalments.

Lump Sum A and B payments cover unused annual leave or unused long service leave. Lump Sum C used to be the component for Payment in Lieu of notice (but not a bona-fide redundancy), classified as an "O" type payment. A Lump Sum D is the tax-free component of a bona-fide redundancy and does not appear on an employee's tax return. Lump Sum E is used when employer make certain Lump Sum Payments in arrears (or back pays). When an employer makes back payment of salary and wages relating to a period PAYEVNT.2018 PAYEVNT.2020 16 PeopleSoft Global Payroll for Australia Single Touch Payroll (Phase 2) Solution Overview Copyright © 2021, Oracle and/or its affiliates more than 12 months before the date that the back pay itself is being paid. A return-to-work amount is paid to induce a person to resume work, on account of either to end industrial action or to leave another employer.

Return to Work Payments will be separately itemised as Lump Sum W rather than included in Gross. Lump Sum E Financial Year – Lump Sum E YTD amounts must be reported by each prior financial year to which the arrears payment relates. Lump Sum payments were previously reported as separate fields within a single Tuple, now it is reported with codes and amount against each Lump Sum types.

RETRO12MTH - Any back payment of remuneration that is accrued or was payable more than 12 months before the date of payment either pay or Update Date.

RETRO CY (Current Year) – Any back payment of remuneration that is accrued or was payable less than 12 months before the date of payment either pay or update date and falls within the same financial year.

RETRO PY (Previous year) - Any back payment of remuneration that is accrued or was payable less than 12 months before the date of payment either pay or update date and falls in the same prior financial year.

## Pages Used to Set Up Single Touch Payroll (STP)

Page Name	Definition Name	Usage
<a href="#">Brackets Data Page</a>	GP_PIN	To retrieve the Cessation Type code by mapping the combination of Action and Action Reasons.
<a href="#">STP Medicare Levy Surcharge Page</a>	GPAU_STP_MLS	Capture employees medicare levy tier information The STP Preparation Process fetches the information into the fourth character of the tax treatment code.
<a href="#">STP 2.0 Update Event AUS Page</a>	GPAU_STP_PERS_DTL	Update event adjustments through the Update Event AUS.
<a href="#">STP Payroll Event File AUS Page</a>	GPAU_STP_RUNCTL	Generate or update Pay Event files. For more information on how to generate pay event file, see <a href="#">Generating Pay Event File</a> .
<a href="#">STP Category Setup AUS Page</a>	GPAU_STP_CAT	Map the Tuple and, Facts along with respective EOY or STP VR Category for extracting data during STP Pre Process for Pay Event Reporting.

## Cessation Type

Services Australia is aiming to implement a solution that uses the expanded STP dataset to streamline the employment separation certificate process. Reporting the type of cessation reason that ended the employment or engagement relationship between the payee and the payer will generally replace the need for payers to provide separate payee employment separation certificates to Services Australia.

ATO has categorised Cessation Reason into the following:

Sl.No	Reason	Code	Description
1	Voluntary	V	An employee resignation, retirement, domestic or pressing necessity or abandonment of employment.
2	Ill Health	I	An employee resignation due to medical condition that prevents the continuation of employment, such as for illness, ill-health, medical unfitness or total permanent disability.

SI.No	Reason	Code	Description
3	Deceased	D	The death of an employee.
4	Redundancy	R	An employer-initiated termination of employment due to a genuine bona-fide redundancy or approved early retirement scheme.
5	Dismissed	F	An employer-initiated termination of employment due to dismissal, inability to perform the required work, misconduct or inefficiency.
6	Contract Cessation	C	The natural conclusion of a limited employment relationship due to contract/engagement duration or task completion, seasonal work completion, or to cease casuals that are no longer required.
7	Transfer	T	The administrative arrangements performed to transfer employees across payroll systems, move them temporarily to another employer (machinery of government for public servants), transfer of business, move them to outsourcing arrangements or other such technical activities.

## Brackets Data Page

Use the bracket data page AUS BR CESATN TYPE to retrieve the Cessation Type code by mapping the combination of Action and Action Reasons.

The advantage of using this bracket is to help customers dynamically accommodate their customer specific Action and Action Reasons.

Navigation:

**Set Up HCM**, and then **Product Related**, and then **Global Payroll & Absence Mgmt**, and then **Elements**, and then **Supporting Elements**, and then **Brackets**

This example illustrates the fields and controls on the Brackets\_Data page.

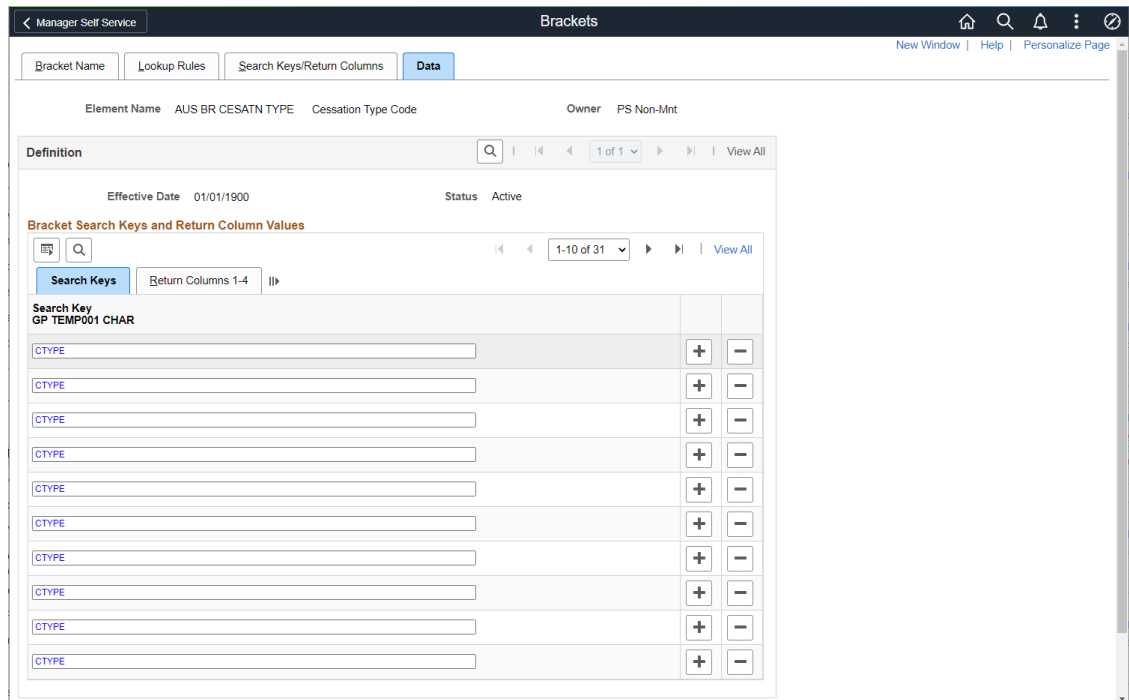

## Tax Offset Amount

The purpose of this fact is to inform government of the employment or engagement relationship and define the withholding rates applied by the payer. This is an annual dollar amount of total offsets claimed by employee to vary their withholding, this field should be supplied only if employee claims an offset.

Payees may be eligible to claim a tax offset to vary their PAYGW amount. The offset is claimed by providing the payer with the completed Withholding Declaration form/s (NAT 3093, 5072)

In PeopleSoft, Tax Offset Amount is fetched from Maintain Tax Data AUS > Total Rebates field.

Maintain Tax Data AUS page

## Maintain Tax Data AUS

Jane Taylor

Person ID KA0001

Tax File Number		1 of 1	View All
*Effective Date	01/01/2000		
*TFN Status	TFN Provided		
Tax File Number	Re-Enter TFN		
Entered	<input checked="" type="checkbox"/> TFN Disclosure to Superannuation		<input type="checkbox"/> TFN Declaration sent to ATO

Tax Details		1 of 1	View All
*Pay Entity	KAAUSB Australian Business Institute		
*Balance Group Nbr	000		
*Tax Scale	2 Tax Free Threshold Claimed		
Basic of Payment	Full Time		
	<input type="checkbox"/> HELP or TBL Debt		
	<input type="checkbox"/> 3F88 Debt		
<b>Medicare Levy Details</b>			
<input checked="" type="checkbox"/> Calculate Levy Adjustment	<input type="checkbox"/> Spouse	Nbr of Dependents	
<b>Rebates</b>			
Other Rebates		Total Rebate	
<b>Tax Adjustments</b>			
<b>Contractor Details</b>			
<input type="checkbox"/> Contractor	ABN	ABN Branch	

## Tax Treatment Code

Tax Treatment Code is used to define the core rate or amount of withholding.

There are two types of tax tables/guidance available to define the core rate or amount of withholding:

- People - Applicable to a type of worker, defined by residency status, profession, age, visa arrangements. There are options within the categories that further define PAYGW variations for thresholds, professions, living arrangements, residency status, regional programme, registration status, instalment rates or work patterns
- Payments - Applicable to a specific type of payment only, defined by circumstances or other factors like Tax Table for unused leave payments on termination of employment, as these apply specifically to the explicit payments.

Permissible variations of the core rate or amount of withholding that “supplement” the PAYGW rate:

- Study and Training Support Loans – where the payee has an obligation to repay a higher rate of withholding when income thresholds are reached.
- Medicare Levy Variations – where the payee may have personal circumstances that meet pre\u0002defined criteria that permit a lower rate of the Medicare Levy component of the withholding rate. The variation includes surcharge, exemptions, reductions.

Purpose of the Tax Treatment field is to inform the ATO of the factors that the payer has applied to determine the withholding for the worker/payee, excluding payment-specific withholding rates.

Tax Treatment Code will be 6-Character Code, where the first two characters have specific values for every payee and characters 3-6 are specific values only if the payee notifies choices.

Navigation

**Set Up HCM**, and then **Product Related**, and then **Global Payroll & Absence Mgmt**, and then **Elements**, and then **Supporting Elements**, and then **Brackets**, and then **AUS BR TXTRMT CODE**

A new bracket AUS BR TXTRMT CODE is created for fetching the Tax Treatment Code by mapping the combination as defined by ATO for various types of Payees.

A new bracket AUS BR TXTRMT CODE is created for fetching the Tax Treatment Code by mapping the combination as defined by authorities for various types of payees.

Bracket for fetching Tax Treatment Code

Manager Self Service | Brackets | New Window | Help | Personalize Page

Bracket Name | Lookup Rules | Search Keys/Return Columns | **Data**

Element Name: AUS BR TXTRMT CODE | Tax Treatment Code | Owner: PS Non-Mnt

Definition | Effective Date: 01/01/1900 | Status: Active

Bracket Search Keys and Return Column Values | 1-10 of 36 | View All

Search Keys | Return Columns 1-4 | Return Columns 5 - 8

Search Key TAX VR EE TXSCL	Search Key TAX VR EE HELP	Search Key AUS VR TX TRMT MLS	Search Key AUS VR EMPL CATGOR		
1	N	X	X	+	-
1	N	Y	X	+	-
1	Y	X	X	+	-
1	Y	Y	X	+	-
10	N	X	X	+	-
10	N	Y	X	+	-
10	Y	X	X	+	-
10	Y	Y	X	+	-
2	N	X	X	+	-
2	N	Y	X	+	-

## STP Medicare Levy Surcharge Page

A new component for STP Medicare Levy Surcharge solution to capture employees medicare levy tier information (Tier 1, 2, and 3).

Use STP Medicare Levy Surcharge (GPAU\_STP\_MLS) page to capture employees medicare levy tier information. The STP Preparation Process fetches the information into the fourth character of the tax treatment code.

This example illustrates the field and controls of STP Medicare Levy Surcharge page.

State Surcharge Rates | STP Medicare Levy Surcharge | New Window | Help | Personalize Page

**STP Medicare Levy Surcharge**

Jane Taylor | Person ID KA0001

Medicare Levy | 1 of 1 | View All

\*Effective Date: 01/01/2022

\*Balance Group Nbr: 000

Tier: 1

Save | Return to Search | Previous in List | Next in List | Notify | Update/Display | Include History | Correct History

### Note

Medicare Levy Surcharge is purely for the reporting purpose and not considered for the taxation. When Payee Tax Scale is '3' or '4R' or '4N' or 'H' then Medicare Levy Surcharge is not provided.

## Update Event

Update Event aligns the latest employer Business Management Software (BMS) data with the last employee data reported to the ATO, or to assist with the End of financial year (EOFY) processes, including finalization and amendments to Single Touch Payroll (STP) for prior finalized years.

After the end of fiscal year (June 30th), any changes made to report employee data for the prior financial year must only be submitted through the update event.

Update event must include the latest Year to Date (YTD) value for all payments (including each Employment Termination Payment (ETP by payment date and code) made in the financial year. It cannot include only the values that have changed.

Employers' pay period totals for gross payments and PAYG withholding cannot be included in an update event as there is no associated payment to the employee when the changes are reported via the update event.

Here are a few examples where the employer can make use of the Update Event:

- Overpayment within a financial year - Where there is no future payment to the employees, YTD amounts should be reduced to reflect the overpayment through an update event.
- Misclassification with no additional payment - misclassification is when information has previously been reported under an incorrect salary and wage item and there is no additional payment to the employee.
- Where an employee is reported under the incorrect ABN or PAYG withholding branch - If an employee has been reported under an incorrect ABN the employer needs to report these amounts under the correct ABN and adjust the employee YTD amounts on the incorrect ABN.

- Overpayment identified after End of Financial Year - If the overpayment occurred in more than one prior year, the employer should provide an update event for each financial year reported via STP.

Steps for running the Update Event:

1. Select the Employee for whom the update event is to be executed. Note: Update Event should always be submitted against the last Pay Event.
2. Click + to add a new row.
3. Select **Update Event**.
4. Update Event Date – This field is enabled once the user selects Update Event Radio Button. This is a mandatory field and the same is used as an indicator to generate the Update Event File.
5. Incorporate the necessary correction or updates to the respective Personal and Payroll fields and save the page.

**Note**

Any data entered using this component will not cascade to Payroll, user need to take care of it.

## STP 2.0 Update Event AUS Page

Use the search based on various options like EMPLID, Tax Year, Pay Entity, Pay Group & Calendar Group ID. This is a new component to accommodate the disaggregation and other reporting requirement of STP Phase 2.

Use STP 2.0 Update Event AUS (GPAU\_STP\_PERS\_DTL) page to update event adjustments through the Update Event AUS.

Navigation

**Global Payroll & Absence Mgmt**, and then **Payee Data**, and then **Single Touch Payroll AUS**, and then **STP 2.0 Update Event AUS**

**Note**

The existing component STP Update Event AUS can be used only for PAYEVNT 2018.

This example illustrates the fields and controls of the STP 2.0 Update Event AUS page.

Manager Self Service | STP 2.0 Update Event AUS

Personal Information | IncomeStream | Allowances | Deductions | RFB/Super

Jane Taylor | Tax Year 2022 | Empl ID KA0001 | Balance Group Nbr 000 | Pay Entity KAAUSBI | Pay Group KAMONTHLY | Calendar Group ID KA 2022M01

Payee Override / Update Event Information

Payee Override |  Update Event | Version 0

**Personal Information**

**Employee Name**

Family Name Taylor | Other Name Elizabeth  
 First Name Jane | Date of Birth 11/21/1964  
 Hire Date 03/04/1984 | Leave Date

**Employee Address**

Address 1 34 Richardson Street  
 Address 2  
 City Fairfield | Email Address  
 Postal Code 2165 | Phone Number 02 9988 7887  
 Country AUS | Australia  
 State NSW | New South Wales

**Employment Conditions**

Employment Basis Full Time | Tax Offset  
 Tax Treatment RTXXXX

**Payroll Event**

Final Event Indicator

**Note**

The page lists all Payee data for which payroll are finalized and Pay Event File are already generated. Ensure that the update event executes only after the Pay Event in original submitted to ATO. For example, if the Pay Event are submitted for July and Aug 2022, then update event can be submitted only against August 2022 Pay Event.

Field or Control	Description
<b>Personal Information</b>	Employee details are fetched from PS_GPAU_STP_HR_STG table and if user updates any data, the same will consider while reporting Update Event.
<b>Final Event Indicator</b>	This is reported per employee, per payroll ID as part of the employee record. User may submit via pay event or through update event. Users need to select the check box to report this indicator in output file.

Field or Control	Description
<b>Employment Basis</b>	As part of Onboarding tuple in PAYEVNT.2018 and moved into Employment Conditions tuple. A mandatory field to be included in every report of Submit and Update. This field is used to determine hierarchy, for those workers with multiple engagements. Valid values are F = Full time, P = Part time, C = Casual, L = Labour Hire, V = Voluntary Agreement, D= Death benefits, N = non\u0002employee.
<b>Tax offset</b>	Annual dollar amount of total offsets claimed by employee to vary their withholding, this field should be supplied only if employee claims an offset.
<b>Tax treatment Code</b>	The tax treatment of an employee, including main tax scales, student loans and Medicare levy variations.
<b>Cessation Type</b>	to enter when cessation date is provided.
<b>Income Stream</b>	On selecting the calendar group id for which the amendments to be done, the system by default would populate the values submitted in the original file. Earnings information that needs to report in an Update Event should contain changed or corrected year to date values you originally submitted on the employee's Pay Event for the period in the respective fields. For example: If you report the value via Pay Event as \$500.00, and the actual value to correct or change is \$600, then the respective field need to populate with new values as \$600.00 The required data for Wages & Taxation derived from PS_GPAU_STP_PAYTBL & for Employee Termination Payments (ETP) it is PS_GPAU_STP_ETP.
<b>Employee Termination Payments</b>	As per ATO, Employee Termination Payments Codes and Values can iterate up to a maximum of 25 times. Thus, once the user made use of 25 field values, add button will disable from the grid.
<b>Allowances</b>	Modify related values using this field and this can hold maximum of 30 Allowance category. As per ATO, Employee Allowance Codes and values and can be iterated to maximum of 30 times. Thus, once the user enters 30 field values, add button will disable from the grid. Allowances information are derived from PS_GPAU_STP_ALLOW record.
<b>Deductions</b>	Union Fees, Workplace Giving, Child Support Deductions and Garnishees can be modified using this field and can hold maximum of 4-deduction categories. As per ATO, Employee deduction codes and Values and can be iterated up to a maximum of four times. Thus, once the user enters 4 values, the add button will be disabled from the grid. Deduction information derived from PS_GPAU_STP_DED record.

Field or Control	Description
RFB/Super Entitlement	Modify Superannuation Contribution Tuple data. Superannuation information derived from PS_GPAU_STP_RFB/PS_GPAU_STP_SUP record.

## STP Payroll Event File AUS Page

Use the STP Payroll Event File AUS page (GPAU\_STP\_RUNCTL) to generate or update Pay Event files. For more information on how to generate pay event file, see [Generating Pay Event File](#)

Navigation:

**Global Payroll & Absence Mgmt**, and then **Payee Data**, and then **Single Touch Payroll AUS**, and then **STP Update Event AUS**

This example illustrates the fields and controls on the STP Payroll Event File AUS Page (1 of 2). You can find definitions for the fields and controls later on this page.

The screenshot shows the 'STP Payroll Event File AUS' page with the following sections and controls:

- Page Header:** Manager Self Service, STP Payroll Event File AUS, New Window, Help, Personalize Page.
- Run Control ID:** PM
- Buttons:** Report Manager, Process Monitor, Run
- STP Selection Parameters:**
  - \*Tax Year: [Text Input]
  - \*STP File Type: Pay Event (Dropdown)
  - \*Pay Entity: [Text Input with Search Icon]
  - \*Run Type: Test (Dropdown)
  - XML with Root Node
- STP Pay Date Parameters:**
  - Pay Group: [Text Input with Search Icon]
  - Calendar Group ID: [Text Input with Search Icon]
  - Period End Date: [Text Input with Search Icon]
  - Period ID: [Text Input with Search Icon]
  - Payment Transaction Date: [Text Input with Search Icon]
  - \*Reporting Party: Payer/Employer (Dropdown)
  - \*Declaration: True (Dropdown)
- STP Pay Run Parameters:** (Section header visible, content partially obscured)

This example illustrates the fields and controls on the STP Payroll Event File AUS Page (1 of 2)

**STP Pay Run Parameters**

Full File Replacement

Submission ID

**Final Event Indicator**

Not Applicable

All Terminated Payees for this Pay Period

All Active Payees for this Pay Period

All Payees for this Fiscal Year (Excluding already Reported)

---

**Authorization**

I am notifying the ATO that:

- provides my business with lodgement transaction services; and
- my business, for the purpose of its transactions with ATO via the SBR channel, sends (and receives) those transactions to (and from) the ATO via .

I declare the information transmitted in this payroll report is true and correct and I am authorised to make this declaration.

Acknowledgement

Save
Notify

Field or Control	Description
<b>Tax Year</b>	Enter the Fiscal Year for which the update event is processed. For example, enter, "2017" for 2016-17 Tax Year.
<b>STP File Type</b>	Select the STP file type. Available options are: <ul style="list-style-type: none"> <li>• Pay Event</li> <li>• Update Event</li> </ul>
<b>Pay Entity</b>	Select the pay entity, for which the employer would like to generate Payroll Event (PAYEVNT & PAYEVNTEMP).
<b>Run Type</b>	Select the Run Type. Available options are: <ul style="list-style-type: none"> <li>• Test: Use the Test option for testing files to ensure they are complied with the reporting norms before running the final submission.</li> <li>• Production: Use the Production option when you are submitting the final file for payroll processing.</li> </ul>
<b>XML with Root Node</b>	Select the checkbox if you want to generate a temporary XML file with Root Node, which can be viewed in a browser, with the ability to export to excel.  <b>Note:</b> This option is for easier validation. The Final XML file to be submitted to the authorities should be generated without a Root node, which is a non-standard XML structure and thereby does not open properly in a normal browser; instead, the file can be opened and reviewed in text editors, such as Notepad, Notepad++ or Text Pad.
<b>Output</b>	For each entity, there will be a Single File (contains PAYEVNT & PAYEVNTEMP in a single file with Parent and Child) are generated in XML format as per ATO guidelines.

Field or Control	Description
<b>Pay Group</b>	Select the paygroup if you want to generate the file for a particular pay group. For example, if there are pay groups for Weekly and Monthly, employers would be able to generate the separate file for each pay group.
<b>Update Event Date</b>	Select the date on which the update event is carried out for the employees.
<b>Reporting Party</b>	Select the Reporting Party. Available options are: <ul style="list-style-type: none"> <li>• Payer/Employer</li> <li>• Intermediary</li> </ul>
<b>Declaration</b>	Select the option as True or False to indicate whether the terms stated in the Declaration Text have been accepted or declined.
<b>Final Event Indicator</b>	An employer is required to make a declaration to the ATO, that they have provided all the information for each employee for a financial year, by providing the finalization indicator as a part of an employee's Single Touch Payroll report. Select this check box if you want to include this indicator in the final output.
<b>Final Pay Event</b>	This indicates whether the report is the employer's final payroll for the current reporting period. An employer is required to make a declaration to the ATO, that they have provided all the information for each employee for a financial year, by providing the finalization indicator as a part of an employee's Single Touch Payroll report. This declaration allows ATO to make the employee information available for income tax return prefill for employees. It will also update the employee's myGov payroll page, to show that the Single Touch Payroll reported information is final for the financial year.
<b>Submission ID</b>	A unique identifier to identify a payroll event transaction sent to ATO. PeopleSoft while generating the Pay Event automatically generates Submission ID.

## STP Category Setup AUS Page

Use the STP Category Setup AUS page (GPAU\_STP\_CAT) to map between XML Tuple with Category and XML Fact with Sub Category. SOVR Variable determines, the Variable that is assigned in the Earnings and Deductions to determine the SOVR category in the Supporting element override. The setup uses the EOY VR CATEGORY (existing one which is used for generating the Payment Summaries), and STP VR CATEGORY/STP VR P2 CATEGORY (these are new variables created to map against respective earnings/deductions) required for STP file generation and reporting. For each active SOVR category against an earning or a deduction, a new variable should be assigned. To accommodate three active SOVRs in the supporting element override, customers can use these delivered variables.

Navigation:

**Set Up HCM, and then Product Related, and then Global Payroll & Absence Mgmt, and then Reports, and then STP Category Setup AUS**

The STP Category setup AUS page sets the mapping between XML Tuple with Category and XML Fact with Subcategory.

This example illustrates the STP Category Setup AUS page.

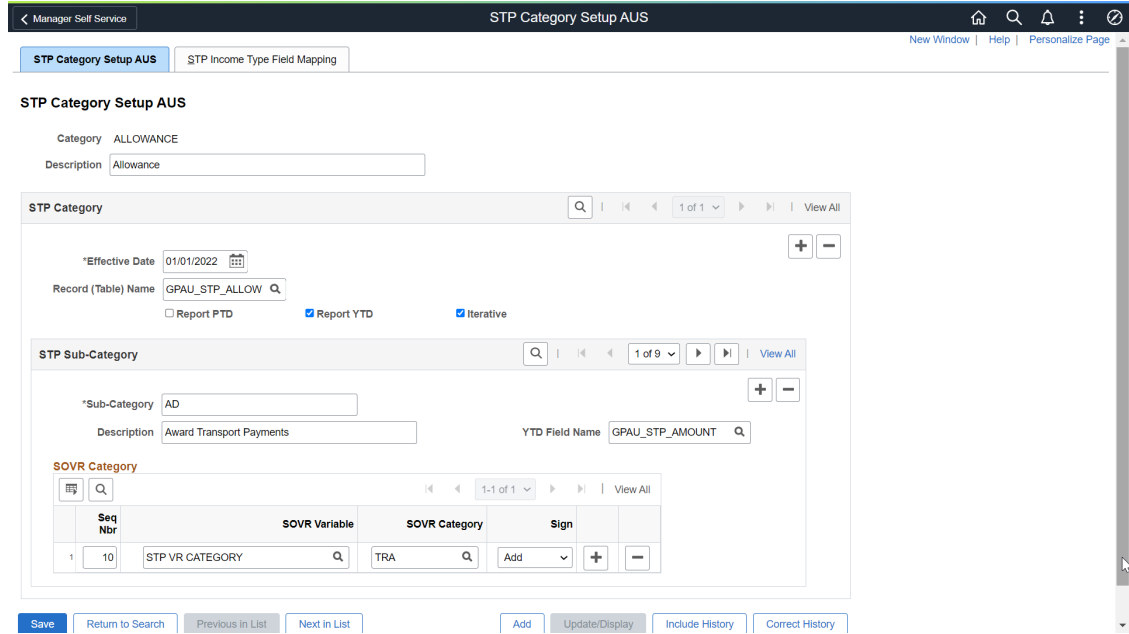

**Field or Control**

**Description**

**Effective Date**

Date between the Period Begin Date and Period End Date of the Go-live period.

The below dates should be synced when transitioning from Phase 1 to Phase 2 (any date between the Period Begin Date and Period End Date of the Go-live period):

- Effective date of STP Category Setup
- Effective date of STP Income Type Field mapping
- Begin Date of the SOVR category in the Supporting element override of Earnings and Deductions

**Record (Table) Name**

Select the Staging Record where the data to be stored for reporting while running STP Preparation Process. This field is to define the Staging table record where the data to be stored for final reporting.

**Report PTD**

Select the check box if PTDs are required under the specified Category and Sub-Category. This enables PTD field name where we can define the Field of the staging table defined under Record Name. The PTD value calculated update in the respective field defined.

Field or Control	Description
<b>Report YTD</b>	Select the check box if YTDs are required under the specified Category and Sub-Category. This enables YTD field name where we can define the Field of the staging table defined under Record Name. The YTD value calculated update in the respective field defined.
<b>Iterative</b>	Select this checkbox if the amounts under a tuple needs to be reported as separate collection. For example, Allowance, Deduction, Paid Leave, Lumpsum Payments, etc. <b>Note:</b> YTD Field Name will be the same for all the Sub-Categories of Iterative Category.
<b>Sub Category</b>	This field stores the list of XML facts with amounts to be reported under the respective Categories.
<b>Description</b>	Meaningful description for the sub category.
<b>YTD Field Name</b>	This field stores the Year to date amounts to be reported in PAYEVENTEMP XML extracted during STP Prep process AUS. The List of Values displays the fields of the Record Name specified under the Category.
<b>SOVR Variable</b>	Select the variable that is assigned in the Earnings. This determine the SOVR category and the Supplementary Element Override. The SOVR Variable are either EOY VR Category or STP VR Category.
<b>SOVR Category</b>	Select the respective EOY VR or STP VR Category corresponding to those earnings and deductions that is required for each facts of that Tuple. This determines the actual SOVR categories that contribute to the Sub-Category, which is the Final amount to display in the report.
<b>Sign</b>	Determines whether the earnings or deductions of the selected SOVR to be added or deducted for reporting.

**Note**

This setup is pre-seeded as system data and employer can make necessary changes to set up additional categories as part of STP Reporting.

### STP Income Type Field Mapping

STP Income Type Field Mapping is to draw between fields for Gross, Tax, CDEP, EFEI between GPAU\_STP\_PAYSTG and GPAU\_STP\_PAYTBL to convert payroll data stored in Phase 1 staging record into Phase 2 format of reporting. This transition is from horizontal to vertical data.

In Phase 2, Gross, tax, bonus and commissions, directors' fee, overtime payments, CDEP, EFEI are still stored in PS\_GPAU\_STP\_PAYSTG but data is converted and stored in

PS\_GPAU\_STP\_PAYTBL to make it compatible with the latest format. This conversion is done with the below setup.

STP Income Type Field mapping should be done only for the categories related to Income types like INB, IAA, WHM, FRGN, JPD (not valid for Phase 2).

This mapping needs to be done if the customer wants to add a new Income type as a Category.

**Note**

STP Income Type Field Mapping should be done only if customer has any specific income types which is not delivered by Oracle.

This example illustrates the fields and controls on the STP Income Type Field Mapping page.

STP Category Setup AUS

STP Income Type Field Mapping

### STP Category Setup AUS

Category **INB**

Description

Record Field Mapping
1 of 1
View All

Effective Date

Target Record

Income Type

Source Record

+ -

**Record Field Mapping**

	Target Field	Source Field		
1	<input style="width: 90%;" type="text" value="GPAU_STP_CDEP_PAY"/>	<input style="width: 90%;" type="text" value="GPAU_INB_CDEP_PAY"/>	+	-
2	<input style="width: 90%;" type="text" value="GPAU_STP_EFEI_PAY"/>	<input style="width: 90%;" type="text" value="GPAU_INB_EFEI_PAY"/>	+	-
3	<input style="width: 90%;" type="text" value="GPAU_STP_GROSS_PA"/>	<input style="width: 90%;" type="text" value="GPAU_INB_GROSS_PAY"/>	+	-
4	<input style="width: 90%;" type="text" value="GPAU_STP_TAX_WHELI"/>	<input style="width: 90%;" type="text" value="GPAU_INB_TAX_WHELC"/>	+	-

Field or Control	Description
<b>Target Record</b>	This field is to define the Staging table record of Phase 2.
<b>Source Record</b>	This field is to define the Staging table record of Phase 1.

Field or Control	Description
<b>Income Type</b>	This field determines the income type.

To add a new income type, perform the following:

1. Add the new SOVR Category to the STP SOVR Setup Component.
2. Map new Earnings & Deductions with new SOVR Category in the Supporting Element Override.
3. Add a new row in STP Category Setup with the Category of the new Income Type.
4. Enter the STP Phase 2 Effective Date and Record Name as GPAU\_STP\_PAYSTG.
5. Add the new Sub-Categories for GROSS and TAX along with mapping the respective SOVR Categories.
6. Enter the YTD field name for Gross and Tax as the respective fields delivered for each income type.
7. In STP Income Type Field Mapping, add a new row with STP Phase 2 Effective Date.
8. Select the Target Record as GPAU\_STP\_PAYTBL and Source Record as GPAU\_STP\_PAYSTG.
9. Field mapping should be done for Gross and Tax.

## Generating Pay Event File

This section provides an overview of Pay Event File file and discusses how to create a Pay Event file.

### Pages Used to Generate Pay Event File

Page Name	Definition Name	Usage
<a href="#">STP Payroll Event Prep AUS Page</a>	GPAU_STP_PREP_RN	Fetch or extract Payroll and Non-Payroll Data required for generating STP Pay Event (PAYEVNT and PAYEVNTEMP).
<a href="#">STP Payroll Event File AUS Page</a>	GPAU_STP_RUNCTL	Generate Pay Event files which is to be submitted to principal revenue collection agency. each time the Employer makes a Payment to an Employee.
<a href="#">STP PTD Override Page</a>	GPAU_STP_EVTOVR	Change the PTD Values for Payer Total PAYGW Amount and Payer Total Gross Payments after completing the STP PAYEVNT process run.

## Understanding Pay Event Files and File Generation Process

A pay event is created when an employer pays the employee a certain amount for the services they have done for the organization within a certain period. It is the combination of the financial records of their employees' salaries, wages, allowances and deductions.

As per the regulation, this information should be submitted to the principal revenue collection agency, as and when the payment happens. Pay Event data consist of employer and individual employee data.

- PAYEVNT - Summary Report which helps the Employer, Tax Agent or Business Representative to notify for the payments made to their employees along with related Tax and Super obligations validated and processed by SBR.
- PAYEVNTEMP - Detail Report which helps the Employer, Tax Agent or Business Representative to notify for the payments made to an individual employees along with related Tax and Super obligations that is validated and processed by SBR.

For more information on steps to be completed in PeopleSoft before STP Pay Event generation, see [Setting Up Single Touch Payroll \(STP\)](#).

Once the set up is complete, you can move to the preparation processes:

- STP Preparation Process: Preparation process is part of the Pay Event to populate the payroll result values. The user has the option to run this process before/after finalization of payroll for the respective pay period. These processes update the Payroll data that is required for generating the PAYEVNT & PAYEVNTEMP file.
- STP FBT Collection Process: As part of STP, it requires that you report FBT- liable earnings when the gross-up value (of all FBT-liable earnings) exceeds a minimum figure. To have the system calculate the reportable fringe benefits amount for inclusion on the Pay Event, you run a collect process. An employer may report YTD RFBA through a payroll event (if the information is available in payroll), throughout the financial year. This process takes care of seeding the required data for FBT values that are required for STP PAYEVNTEMP Reporting.

#### Note

Before running the STP Preparation Process, the SOVR Category setup needs to be defined for the sub-categories and the respective SOVR Value. This is because the preparation process makes a call to Report Data with the help of the Run Control parameters. The Report Data results are stored in GPAU\_STP\_TMP (instance Number). Preparation process uses a list of temporary tables for processing the payroll data to get the results. These final processed data are stored based on the STP category setup.

## STP Payroll Event Prep AUS Page

Use the STP Payroll Event Prep AUS Page (GPAU\_STP\_PREP\_RN) to update the Payroll Data required for generating the PAYEVNT & PAYEVNTEMP file.

#### Note

You can run this process before or after the finalization of payroll for the respective pay period.

Navigation:

**Global Payroll & Absence Management** , and then **Authority Correspondence**, and then **STP Payroll Event Prep AUS**

This example illustrates the fields and controls on the STP Payroll Event Prep AUS page.

You can run the process by selecting the appropriate options; respective fields are enabled based on the run control parameters. Tax Year and Pay Entity are key fields. The process can run by Pay Entity, Group List, Streams, Pay Group, Period End Date, or individual Employee ID. Some fields will only show with certain processing options.

Field or Control	Description
<b>Process by</b>	<p>Select the processing option.</p> <ul style="list-style-type: none"> <li>• <b>Empl Id:</b> Select the option as Employee ID, if you want to run the process only for one employee. On selecting this option, fields to capture Employee ID and Balance Group Number will be displayed.</li> <li>• <b>Grp List:</b> Select the option as Group List, if you want to run the process for a group of employees. On selecting this option, a field to capture Group List ID will be displayed.</li> <li>• <b>Pay Entity:</b> Select the option as Pay Entity, if you want to run the process for a specific pay entity.</li> <li>• <b>Pay Group:</b> Select the option as Pay Group, if you want to run the process only for a specific pay group. On selecting this option, a field to capture Pay Group will be displayed.</li> <li>• <b>Streams:</b> Select the option as Streams, if you want to run the process for a given payroll, stream. On selecting this option, a field to capture Stream Number will be displayed.</li> <li>• <b>Period End Date:</b> Select the option as Period End Date, if you want to run the process for a list of CAL_RUN_IDS having the same Period End Date. On selecting this option, two fields, Period End Date and Period ID are displayed.</li> </ul>
<b>Tax Year</b>	<p>Enter the Tax Year for which this Payroll Event (PAYEVNT &amp; PAYEVNTEMP) needs to be processed.</p>

Field or Control	Description
<b>Pay Entity</b>	The Pay Entity for which data should extracted. Define the pay entity, for which the employer would like to include the payroll data for Payroll Event (PAYEVNT & PAYEVNTEMP).
<b>Calendar Group ID</b>	Enter the Calendar Group ID for which the employer would like to consider the payroll results for Payroll Event (PAYEVNT & PAYEVNTEMP). If Process by field is set as Period End Date, then the Calendar Group ID field is not available..
<b>Employee ID &amp; BAL GRP</b>	If the user wants to run the process for only one employee, then "Processing Option" should be set to Employee ID and enter the Employee ID in the relevant field.
<b>Period End Date</b>	Click the Period End Date field. This displays a list of CAL GRP IDs which has the same Pay Period End Date for that Pay Entity. Select the required Period End Date.
<b>Period ID</b>	Period ID associated with the Pay Period End Date. Period End Date remains the same for multiple Period IDs. If the user selects a Period End Date followed by a Period ID, only those CAL GRP IDs associated with period ID are displayed under the Processed Calendar Groups section.
<b>Run</b>	Select the Run button, to run the preparation process. This process extracts the payroll and non payroll data required for STP Pay Event.
<b>Group List</b>	To run the process for a group of employees, then "Processing Option" should set to Group List and enter the Group List ID in the relevant field.
<b>Streams</b>	To run the process for a given payroll stream, then "Processing Option" should be set to Streams and enter the Stream Number in the relevant field.
<b>Period End Date</b>	Select to run the process for a list of CAL_RUN_IDs having the same Period End Date. On selecting this option, two fields, Period End Date and Period ID are displayed.

## STP Payroll Event File AUS Page

Use the STP Payroll Event File AUS page (GPAU\_STP\_RUNCTL) to generate Pay Event files.

The Pay Event File needs to be submitted to principal revenue collection agency each time the Employer makes a Payment to an Employee. When you run the process, the payment data for the relevant period for the PAYGW scheme is picked up. It includes all 'employment' data within the PAYGW and all the payments & deductions report as year to date figures (YTD). PAYEVNT is the Summary Report that assist Employer, Tax Agent or Business Representative to notify the authority about the payments made to their employees along with the related Tax and Super obligations.

Navigation:

**Global Payroll & Absence Management** , and then **Authority Correspondence**, and then **STP Payroll Event File AUS**

This example illustrates the fields and controls on the STP Payroll Event File AUS page.

The screenshot shows the 'STP Payroll Event File AUS' page. At the top, there is a navigation bar with 'Manager Self Service' and 'STP Payroll Event File AUS'. Below this, there are buttons for 'Report Manager', 'Process Monitor', and 'Run'. The main content area is divided into three sections:

- STP Selection Parameters:** Includes fields for '\*Tax Year' (2022), '\*STP File Type' (Update Event), '\*Pay Entity' (KAAUSMI), '\*Run Type' (Test), and a checkbox for 'XML with Root Node'.
- STP Pay Date Parameters:** Includes fields for 'Pay Group', '\*Update Event Date', '\*Reporting Party' (Payer/Employer), and '\*Declaration' (True).
- STP Pay Run Parameters:** Includes a field for 'Previous BMS Id'.

This example illustrates the fields and controls on the STP Payroll Event File AUS page.

The screenshot shows the 'STP Pay Run Parameters' and 'Authorization' sections. The 'STP Pay Run Parameters' section includes:

- Checkboxes for 'First Pay Event' and 'Full File Replacement'.
- A 'Submission ID' field.
- A 'Final Event Indicator' section with radio buttons for:
  - Not Applicable (selected)
  - All Terminated Payees for this Pay Period
  - All Active Payees for this Pay Period
  - All Payees for this Fiscal Year (Excluding already Reported)

The 'Authorization' section includes a declaration: 'I am notifying the ATO that: ... provides my business with lodgement transaction services; and ... my business, for the purpose of its transactions with ATO via the SBR channel, sends (and receives) those transactions to (and from) the ATO via.' Below this is a checkbox for 'Acknowledgement' which is checked.

At the bottom, there are buttons for 'Save', 'Return to Search', 'Previous in List', 'Next in List', 'Notify', 'Add', and 'Update/Display'.

Field or Control	Description
<b>STP Selection Parameters</b>	
<b>Tax Year</b>	Specify the Calendar Year in which Tax Year Begins. For example, "2022" for 2021-22 Tax Year.

Field or Control	Description
<b>STP File Type</b>	<p>Select the type of file. Available options are:</p> <ul style="list-style-type: none"> <li>• Pay Event</li> <li>• Update Event</li> </ul> <p><b>Note:</b> It is not mandatory to finalize the payroll to generate the PAYEVNT output file.</p>
<b>Pay Entity</b>	<p>The Pay Entity for which data is reported. Select the pay entity, for which the employer would like to generate Payroll Event (PAYEVNT &amp; PAYEVNTEMP).</p>
<b>Pay Group</b>	<p>Optional field to allow for additional filtering of the employees included in the file. Employers have the option to generate for a particular pay group. For e.g., if there are pay groups for Weekly and Monthly, employers would be able to generate the separate file for each pay group.</p>
<b>Update Event Date</b>	<p>Date on which Update carried out for the employees Year to Date Values that submitted to the authority via Pay Event. This Update Event Date is key to generate the Update Event output file.</p> <p>By default, 'Test' is selected.</p>
<b>XML with Root Node</b>	<p>On selecting this check box, XML file generation process will generate XML file with dummy Root Node and the file can be opened in any browser. Validation file will also be generated against the generated XML file with dummy Root Node. XMLs generated without Root Node will not open in any of the browser. Final XML file needs to be opened in Notepad, Notepad++, Text Pad, etc.</p> <p>By default, this check box is unchecked. When the check box is unchecked, XML file generation process will generate XML file without Root Node and hence no validation file will be generated.</p>
<b>Pay Group</b>	<p>Specify the pay group if you want to filter the employees to be included in the file, based on their pay group. For example, if there are pay groups for Weekly and Monthly, employers can select the particular pay groups and generate separate files for each pay group.</p>
<b>Output</b>	<p>For each entity, there will be a Single File (contains PAYEVNT &amp; PAYEVNTEMP in a single file with Parent and Child) are generated in XML format as per guidelines.</p>

Field or Control	Description
<b>Final Pay Event</b>	This indicates whether the report is the employer's final payroll for the current reporting period. An employer is required to make a declaration to the authority, that they have provided all the information for each employee for a financial year, by providing the finalization indicator as a part of an employee's Single Touch Payroll report. This declaration allows the agency to make the employee information available for income tax return prefill for employees. It will also update the employee's myGov payroll page, to show that the Single Touch Payroll reported information is final for the financial year.
<b>Period End Date</b>	Enter the Period End Date for the payment period to report Pay Event.
<b>Period ID</b>	<p>Period ID associated with the Pay Period End Date. The Period End Date remains the same for multiple Period IDs.</p> <p>If the user selects a Period End Date followed by a Period ID, only those CAL GRP IDs associated with period ID are displayed under the Processed Calendar Groups section.</p>
<b>Submission ID</b>	A unique identifier to identify a payroll event transaction sent to the Authorities. PeopleSoft while generating the Pay Event automatically generates Submission ID.
<b>Payment Transaction Date</b>	<p>Select the required payment transaction date.</p> <p>If the Payment Period End Date has multiple 'Payment Dates', then Maximum Payment Date is considered as the Payment Transaction Date by default.</p>
<b>Reporting Party</b>	<p>Specify the reporting party. Available options are:</p> <ul style="list-style-type: none"> <li>• Payer/ Employer</li> <li>• Intermediary</li> </ul> <p>By default, 'Payer/ Employer' is selected.</p>
<b>Declaration</b>	Select 'True' or 'False'. This field indicates that the terms stated in the Declaration Text have been accepted or declined
<b>Previous BMS ID</b>	This can only be reported as part of an Update Event. If the Payer is amending a prior financial year finalised income statement of a payee where BMS and Payroll ID is changed, then the Previous BMS Id should be supplied.

Field or Control	Description
<b>First Pay Event</b>	<p>Select this option if you are submitting the Pay Event for the Pay Entity/Pay Group for the first time. When you are submitting the First pay Event, other than the employees who have been paid in the period reported, the details about any leaves from the current Tax Year is also added in the report to ensure that their figures are also reported.</p> <p>This indicates whether the report is the employer's final payroll for the current reporting period. An employer is required to make a declaration, that they have provided all the information for each employee for a financial year by providing the finalization indicator as a part of an employee's Single Touch Payroll report. This declaration allows to make the employee information available for income tax return prefill for employees. It will also update the employee's myGov payroll page, to show that the Single Touch Payroll reported information is final for the financial year. Once you select this option, screen refreshes to display the 'Payment Date' field instead of 'Calendar Group' field.</p> <p><b>Note:</b> This field should only ever be use on your 'First Pay Event'. No subsequent Pay Event files must generate using this option, including new Tax Years or Pay Periods.</p>
Full File Replacement	<p>A full file replacement provides the ability for an employer to replace the latest pay event file that was send to the agency in error or if it contains significant corrupt data.</p>

This example illustrates the STP Payroll Event File AUS page when First Pay Event is selected.

**STP Selection Parameters**

\*Tax Year: 2019

\*STP File Type: Pay Event

\*Pay Entity: KAAUSBI Australian Business Institute

\*Run Type: Test

XML with Root Node

---

**STP Pay Date Parameters**

Pay Group:

\*Payment Date:

\*Reporting Party: Payer/Employer

\*Declaration: True

---

**STP Pay Run Parameters**

First Pay Event

Full File Replacement

Submission ID:

**Final Event Indicator**

Not Applicable

All Terminated Payees for this Pay Period

All Active Payees for this Pay Period

All Payees for this Fiscal Year (Excluding already Reported)

---

**Authorization**

I am notifying the ATO that:

- provides my business with lodgement transaction services; and
- my business, for the purpose of its transactions with ATO via the SBR channel, sends (and receives) those transactions to (and from) the ATO via .

I declare the information transmitted in this payroll report is true and correct and I am authorised to make this declaration.

Acknowledgement

Field or Control	Description
<b>Final Event Indicator</b>	Select this option if you are submitting the final payment for the reporting period of that fiscal year. An employer is required to make a declaration to the agency, that they have provided all the information for each employee for a financial year, by providing the finalization indicator as a part of an employee's Single Touch Payroll report.
<b>Full File Replacement</b>	Select this option if you are trying to replace the latest pay event file that is submitted to the agency with a new one. A full file replacement provides the ability for an employer to replace the latest pay event file submitted to the principal revenue collection agency, if it has any error, or contains significant corrupt data.
<b>Submission ID</b>	You need to select a submission ID if you have selected the option for Full File Replacement. It is a unique identifier to identify a payroll event transaction that is sent to principal revenue collection agency. PeopleSoft automatically generates the Submission ID while the Pay Event file is created.

Field or Control	Description
<b>Acknowledgment</b>	Each time the file has to be generated, the user selects this check box to indicate that the file is authorized to be sent by the Sending Service Provider and it is true and correct. This declaration must be auditable so that an auditor could go back and see who checked the box. In order to meet the authorization and declaration, consent is included as part of STP Payroll Event File AUS.

## STP PTD Override Page

Use the STP PTD Override page (GPAU\_STP\_EVTOVR) if you want to change the PTD Values for Payer Total PAYGW Amount and Payer Total Gross Payments after you completed STP PAYEVNT process run.

**Note**

The new PTD value you enter will override the existing value in PAYEVENT. This is not a page to add delta value; it designed to enter expected PTD value, which is required to report in PAYEVNT against each Pay Period.

Navigation:

**Global Payroll & Absence Management** , and then **Authority Correspondence**, and then **STP PTD Override**

This example illustrates the STP PTD Override page.

### STP PTD Override

*Pay Entity	<input type="text" value="KAAUSBI"/>	Australian Business Institute
*Tax Year	<input type="text" value="2022"/>	
Calendar Group ID	<input type="text" value="KA 2022M01"/>	KA 2022M01 Monthly
Period End Date	<input type="text"/>	

#### PTD Adjustment details

Payer Total PAYGW Amount	<input type="text" value="0.00"/>
Payer Total Gross Payments	<input type="text" value="0.00"/>
Payer Total Deductions Amount	<input type="text" value="0.00"/>
Payer Total Garnishee Amount	<input type="text" value="0.00"/>

Field or Control	Description
<b>Pay Entity</b>	The Pay Entity for which data is reported. Select the pay entity, for which the employer would like to generate Payroll Event.
<b>Tax Year</b>	Enter the Calendar Year on which Tax Year Begins. For example, "2017" for 2016-17 Tax Year.
<b>Calendar Group ID</b>	Select the Calendar Group ID for the payroll that you want to report Pay Event.
<b>Period End Date</b>	Enter the Period End Date for the payment period to report Pay Event.
<b>Payer Total PAYGW Amount</b>	Value during the relevant period, for the amount withheld under the Pay As You Go (PAYG).
<b>Payer Total Gross Payments</b>	The total of salary, wages and other payments paid during the reporting period from which an amount must be withheld.
<b>Payer Total Deduction Amount</b>	Value during the relevant period, for the amount deducted towards Court Orders.
<b>Payer Total Garnishee Amount</b>	Value during the relevant period, for the amount deducted towards Child Support.

 **Note**

Calendar Group ID and Period End date are mutually exclusive. User can override PTD values based on calendar group ID or period end date.

Field or Control	Description
<b>Payer Total PAYGW Amount</b>	Value during the relevant period, for the amount withheld under the Pay As You Go (PAYG).
<b>Payer Total Gross Payments</b>	The total of salary, wages and other payments paid during the reporting period from which an amount must be withheld.

## Reconciling STP Data

The STP Reconciliation Process reconciles STP output files with Payment Summary Data and payroll results for Phases 1 and 2.

This topic discusses:

- Reconciling STP I Data
- Reconciling STP II Data

### Reconciling STP I Data

In Single Touch Payroll (STP), a Payroll Event (PAYEVNT & PAYEVNTEMP) is created and submitted to ATO each time employees are paid. Before submitting the data to ATO, employers

need to check and confirm that the Payroll Event totals match with their payroll results on a Period to Date (PTD) and a Year to Date (YTD) basis. Using the STP Reconciliation process employers can generate reports and perform distinct function to compare values reported in the PAYEVNTEMP file to actual payroll result values at payee level.

Once STP Preparation process is complete, you can run the PSM Data Creation process, which also generates the data for STP reconciliation /comparison. The Create Payment Summary Data process updates the data in the respective staging tables as defined in the configuration. PS Queries are used to compare STP and PSM results.

This image illustrates the STP Reconciliation Process Flow for Phase I.

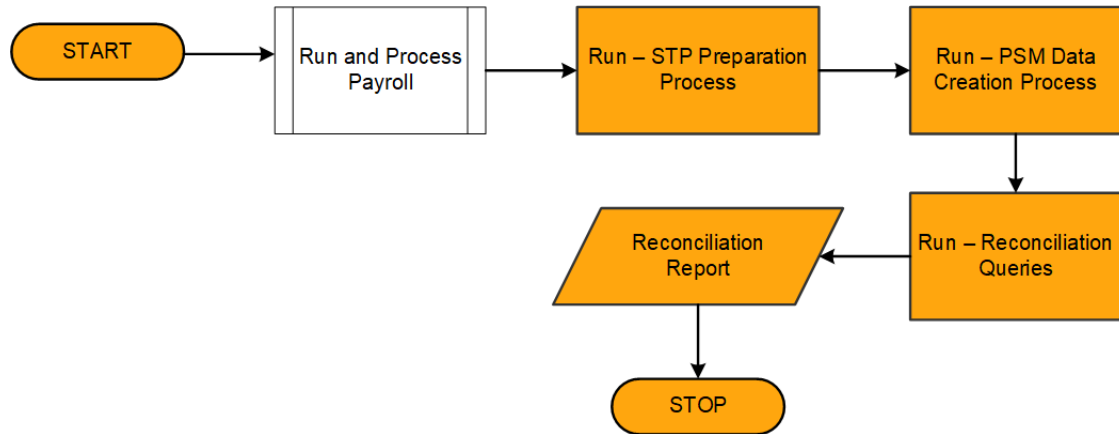

## Page Used to Generate Data for STP I Reconciliation

Page Name	Definition Name	Usage
<a href="#">Create Pmnt Summary Data AUS Page</a>	GPAU_RC_FBT_COLLEC	To modify the given personal information of an employee after the end of fiscal year.

## Create Pmnt Summary Data AUS Page

Use the Create Pmnt Summary Data AUS page (GPAU\_RC\_FBT\_COLLEC) to generate data for reconciliation/comparing with STP data. This process generates a payee's payment summary information.

Navigation:

**Global Payroll & Absence Mgmt** , and then **Year-End Processing**, and then **Create Pmnt Summary Data AUS Page**

This example illustrates the Create Pmnt Summary Data AUS Page.

### Create Pmnt Summary Data AUS

Run Control ID 1

[Report Manager](#)

[Process Monitor](#)

**Run**

\*Tax Year

Update if Record Exists

Include Unfinalized Calendars

#### Population

[Pay Entity List](#)

[Pay Group List](#)

[Payee List](#)

Field or Control	Description
<b>Tax Year</b>	Enter the tax year.
<b>Update if Record Exists</b>	Select this check box if you want to update the records. This is applicable only if you are running the process for finalized payroll calendars.
<b>Include Unfinalized Calendars</b>	Select this check box to run Create Payment Summary Data process for the open payroll calendars.  <b>Note:</b> Use the option to include unfinalized calendars only if you are generating payment summary for reconciling STP. If the Payment Summary is generated for the formal year-end reporting, it should be based on finalized results.
<b>Pay Entity List, Pay Group List and Payee List</b>	Enter the payee population based on which the data is generated. It can be pay entity, pay group, or payee list.

#### PS Queries

Once the Create Payment Summary Data process updates the data in the respective staging tables as defined in the configuration, the following PS Queries are run to compare STP and PSM results.

Query Name	Purpose
GPAU_STP_RECON_GROSS_TAX	Reconcile Gross and Tax of INB Payees
GPAU_STP_RECON_GROSS_TAX_FRGN	Reconcile Gross and Tax of Foreign Payees
GPAU_STP_RECON_ALLOW	Reconcile Allowances
GPAU_STP_RECON_DED	Reconcile Deductions
GPAU_STP_RECON_ETP	Reconcile Termination Payments

## Reconciling STP II Data

STP II Reconciliation process generates two reports that are used by employers to check their Single Touch Payroll totals match with those of their payroll results on a Period to Date (PTD) and a Year to Date (YTD) basis.

The STP reconciliation process involves three-way matching:

Element	Values
Earnings & Deductions	GP_RSLT_ERN_DED
Accumulators	GP_RSLT_ACUM
STP Tuple	STP Staging Records <ul style="list-style-type: none"> <li>• PS_GPAU_STP_PAYSTG: Payroll Data Staging Record - Single Touch Payroll</li> <li>• PS_GPAU_STP_PAYTBL: STP Payroll Data Staging</li> <li>• PS_GPAU_STP_ALLOW: STP Allowance Staging</li> <li>• PS_GPAU_STP_DED: STP Deduction Staging</li> <li>• PS_GPAU_STP_ETP: ETP Staging Record</li> <li>• PS_GPAU_STP_LUMPSM: STP Lumpsum Staging</li> <li>• PS_GPAU_STP_SUP: STP Super details Staging</li> <li>• PS_GPAU_STP_SS: STP SS Staging</li> <li>• PS_GPAU_STP_RFB: STP RFB Staging</li> <li>• PS_GPAU_STP_PAIDLV: STP Paid Leave Staging</li> </ul>

To run the reconciliation report, perform the following:

1. Run the Payroll
2. Run the STP Payroll Event Prep AUS
3. Run the STP Reconciliation AUS

STPII Flow diagram

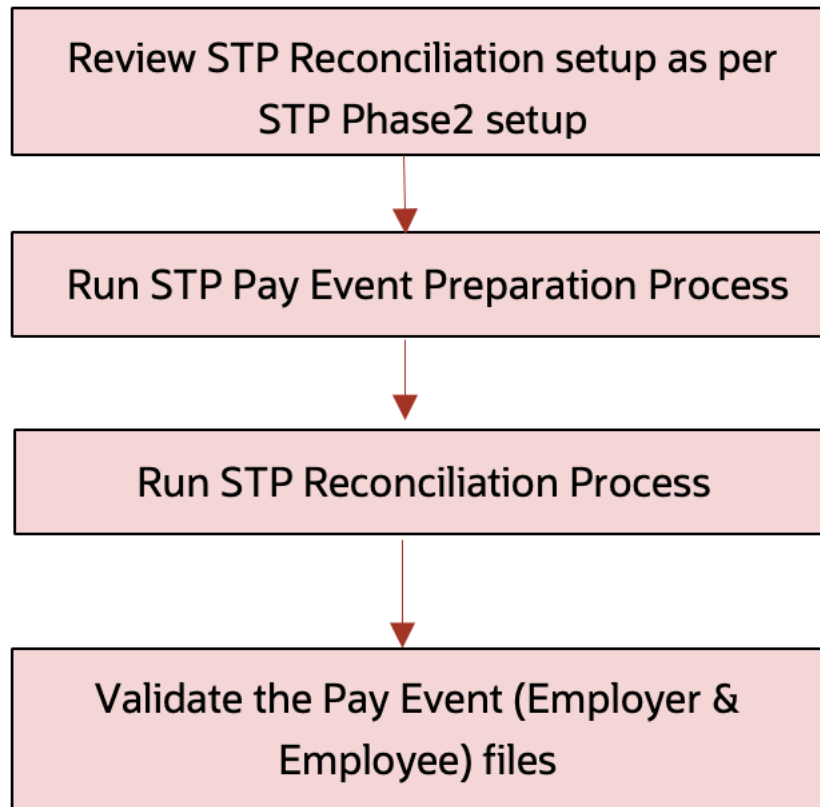

**Note**

This process flow is applicable only for Phase 2 STP solution.

## Pages Used to Generate Data for STP II Reconciliation

Page Name	Definition Name	Usage
STP Reconciliation Setup AUS page	GPAU_STP_RCAT	To map any customized Earnings/Deductions that are used instead of the PeopleSoft delivered Earnings/Deductions that are being reported in STP.
STP Reconciliation AUS page	GPAU_STP_REC_RCTL	To generate the reconciliation reports,

## STP Reconciliation Setup AUS Page

Use the STP Reconciliation Setup AUS (GPAU\_STP\_RCAT) to map any customized Earnings/Deductions that are used instead of the PeopleSoft delivered Earnings/Deductions that are being reported in STP. It is possible to change the mapping data based on the payroll elements if needed, as it will be prepopulated with data.

Navigation:

**Set Up HCM** , and then **Product Related**, and then **Global Payroll & Absence Management**, and then **Reports**, and then **STP Reconciliation Setup AUS**

This example illustrates the fields and controls of the STP Reconciliation Setup AUS page.

**STP Reconciliation Setup AUS**

STP Report PAYEVNT Description Pay Event Employer

---

**Definition** 1 of 1 | View All

\*Effective Date 01/01/2022

---

**Income Stream and Other Collection** 1 of 3 | View All

\*Collection Name DEDUCTION Description CHILD SUPPORT DEDUCTIONS

---

**Reconciliation Sub-Category** 1-1 of 3 | View All

Sequence	Sub-Category	Description	Element Type	Element Name	Sign
1	10 CSD	Child Support Deduction	Deductions	COURTORDER	Add

Buttons: Save, Return to Search, Previous in List, Next in List, Notify, Add, Update/Display, Include History, Correct History

Field or Control	Description
<b>Effective Date</b>	The date from which the setup is valid. <b>Note:</b> The effective date should be the same as that of STP Phase 2 setup.
<b>Collection Name</b>	The name of the Tuple that are being used for reporting
<b>Sequence</b>	The Sequence Order of the Field on the Report.
<b>Sub-Category</b>	The name of the facts that are being used for reporting under the respective Tuple.
<b>Description</b>	The description of the sub-category.
<b>Sign</b>	Values can be: <ul style="list-style-type: none"> <li>• Add: Specify whether the corresponding field adds to the collection Total.</li> <li>• Subtract: Specify whether the corresponding field deducts from the collection Total.</li> </ul>
<b>Element Type</b>	Displays the Element Type. Values can be: <ul style="list-style-type: none"> <li>• Earning</li> <li>• Deduction</li> </ul>

## STP Reconciliation AUS Page

Use the STP Reconciliation AUS page (GPAU\_STP\_REC\_RCTL) to generate the reconciliation reports that can be used to:

- Compare values reported in the PAYEVNTEMP file to the actual payroll result values.
- Ensure that the values reported in PAYEVNT and PAYEVNTEMP are the same.

Navigation:

**Global Payroll & Absence Management, and then Authority Correspondence , and then STP Reconciliation AUS**

This example illustrates the fields and controls of the STP Reconciliation AUS page.

**STP Reconciliation AUS**

Run Control ID 123      Report Manager    Process Monitor   

**STP Parameters**

\*STP Report       Sub-Category Filters

Process by

\*Tax Year

\*Pay Entity

\*Calendar Group ID

Show EEs with Difference Only     Consider STP Payee Override

Field or Control	Description
<b>STP Report</b>	Select the required report type from the following options: <ul style="list-style-type: none"> <li>• All</li> <li>• Pay Event Employer</li> <li>• Pay Event Employee</li> </ul>
<b>Tax Year</b>	The year for which tax year this Payroll Event Reconciliation (Pay Event Employer & Pay Event Employee) needs to be processed.
<b>Pay Entity</b>	The Pay Entity for which data should extracted. Define the pay entity for which the employer would like to include the payroll data for Payroll Event Reconciliation (Pay Event Employer & Pay Event Employee).
<b>Calendar Group ID</b>	Enter the Calendar Group ID for which the employer would like to consider the payroll results for Payroll Event Reconciliation (Pay Event Employer & Pay Event Employee).
<b>Employee ID &amp; BAL GRP</b>	If the user would like to run the process only for one employee, then "Processing Option" should be set to Employee ID and the Employee ID should be entered in the relevant field.
<b>Group List</b>	If the user would like to run the process for a group of employees, then "Processing Option" should set to Group List and the Group List ID should enter in the relevant field.
<b>Streams</b>	If the user would like to run the process for a given payroll, stream, then "Processing Option" should be set to Streams and the Stream Number should enter in the relevant field.

Field or Control	Description
<b>Period End Date</b>	Select the option as Period End Date, if user wants to run the process for a list of CAL_RUN_IDs having the same Period End Date. On selecting this option, two fields, Period End Date and Period ID are displayed.
<b>Show EEs with Difference Only</b>	Select the check box if you want the report to contain only the employees with differences. Leave the check box blank if you want to include all the employees in the report. By default, this check box is selected.
<b>Consider STP Payee Override</b>	Select the check box if you want the report to include the Payee Override entered by the users. By default, this check box is not selected.
<b>Sub-Category Filters</b>	Sub-Category filters will enable if the STP Report is not "ALL", If you want the report to contain only the selected sub-category against Pay Event Employer or Employee, you need to select the respective sub-category from the filters. By default, sub-category check box is selected for "STP Report" Pay Event Employer and Pay Event Employees.

You can access the output reports from the Report Manager.

This example illustrates the fields and controls on the Report Manager page.

The screenshot shows the 'Report Manager' interface. At the top, there are navigation tabs: 'List', 'Explorer', 'Administration', and 'Archives'. Below the tabs, there are search and filter controls: 'View Reports For' with a dropdown menu, 'Instance' with input fields and a 'Refresh' button, 'Name' with an input field, and 'Created On' with a date picker, 'Last' with a dropdown, and 'Days' with a dropdown.

The main area displays a table of reports. The table has the following columns: Report, Report Description, Folder Name, Completion Date/Time, Report ID, and Process Instance. The table contains 10 rows of report data.

Report	Report Description	Folder Name	Completion Date/Time	Report ID	Process Instance
1 <a href="#">GPAU_STP_REC - PAYEVNTMP_REPORT_2022-09-28-22:15:12.000000.xlsx</a>	GPAU_STP_REC - PAYEVNTMP_REPORT_2022-09-28-22:15:12.000000.XLSX	General	09/28/22 10:15PM	70602	462470
2 <a href="#">GPAU_STP_REC - PAYEVNT_REPORT_2022-09-28-22:15:09.000000.xlsx</a>	GPAU_STP_REC - PAYEVNT_REPORT_2022-09-28-22:15:09.000000.XLSX	General	09/28/22 10:15PM	70601	462470
3 <a href="#">GPAU_STP_REC</a>	STP RECONCILIATION	General	09/28/22 10:15PM	70600	462470
4 <a href="#">PTSF_GENFEED</a>	INDEX SEARCH DOCUMENTS	General	09/28/22 9:55PM	70575	462445
5 <a href="#">PTSF_GENFEED</a>	INDEX SEARCH DOCUMENTS	General	09/28/22 9:50PM	70595	462465
6 <a href="#">PTSF_GENFEED</a>	INDEX SEARCH DOCUMENTS	General	09/28/22 9:49PM	70599	462469
7 <a href="#">PTSF_GENFEED</a>	INDEX SEARCH DOCUMENTS	General	09/28/22 9:43PM	70567	462437
8 <a href="#">PTSF_GENFEED</a>	INDEX SEARCH DOCUMENTS	General	09/28/22 9:42PM	70597	462467
9 <a href="#">PTSF_GENFEED</a>	INDEX SEARCH DOCUMENTS	General	09/28/22 9:41PM	70596	462466
10 <a href="#">PTSF_GENFEED</a>	INDEX SEARCH DOCUMENTS	General	09/28/22 9:38PM	70594	462464

Click on the report hyperlink to view the report and verify the reconciliation output.

## STP Reconciliation Output - BIP Reports

STP Reconciliation Report output are in the form of xls. The delivered BI publisher reports are:

- Pay Event Employer Report
- Pay Event Employee Report

The Pay Event Employer Report will have two sheets Pay Event Sheet and Pay Event Element Detail sheet.

- Pay Event Employer Sheet provides the comparison of the Payroll accumulator results against the STP results. There are in turn two sections in this sheet, the Summary and Employee Level grouped based on the category and sub-category defined in the reconciliation setup.
- Pay Event Employer Element Detail provide the details of the employee that got processed in the payroll along with the Previous YTD values so that customer can easily verify the YTD values that is getting reported STP by adding up the current PTD and previous YTD for each element. The elements in this sheet are grouped based on the category and sub-category defined in the reconciliation setup.

The Pay Event Employee Report will have two sheets Pay Event Sheet and Pay Event Element Detail sheet.

- Pay Event Employee Sheet provides a comparison of the Payroll accumulator results against the STP results. There are in turn two sections in this sheet, the Summary and Employee Level grouped based on the category and sub-category defined in the reconciliation setup.
- Pay Event Employee Element Detail provide the details of the employee that got processed in the payroll along with the Previous YTD values so that customer can easily verify the YTD values that is getting reported STP by adding up the current PTD and previous YTD for each element . The elements reported in this sheet are grouped based on the category and sub-category defined in the reconciliation setup.

### Sample Output

Below are sample outputs for Pay Event Employer Reports and Pay Event Employee Reports:

#### Pay Event Employer Report - Sample Output

Type	Income Type	Category	Payroll ID	Hire Date	Leave Date	Employee Count	Sub-Category	Payroll [PTD]	STP [PTD]	Difference
Summary	N/A	DEDUCTION	N/A	N/A	N/A	1	CSD	200.00	200.00	0
Summary	N/A	DEDUCTION	N/A	N/A	N/A	2	CSG	433.34	433.34	0
Summary	N/A	GROSS	N/A	N/A	N/A	34	GROSS	185,735.49	185,735.49	0
Summary	N/A	PAYGW	N/A	N/A	N/A	29	PAYGW	30,787.00	30,787.00	0
Type	Income Type	Category	Payroll ID	Hire Date	Leave Date	Employee Count	Sub-Category	Payroll [PTD]	STP [PTD]	Difference
EmployeeLevel		DEDUCTION	KA0001000	1984-03-04		N/A	CSD	200.00	200.00	0
EmployeeLevel	SAW	GROSS	KA0001000	1984-03-04		N/A	GROSS	5,050.48	5,050.48	0
EmployeeLevel	SAW	PAYGW	KA0001000	1984-03-04		N/A	PAYGW	949.00	949.00	0
EmployeeLevel	SAW	GROSS	KA0002001	2003-11-15		N/A	GROSS	2,571.97	2,571.97	0

#### Pay Event Employer Element Details Report - Sample Output

**Pay Event STP Reconciliation Report Detail**

Pay Entity :000000  
 Paygroup :000000  
 Cal Run ID :000000

Type	Income Type	Category	Payroll ID	Sub-Category	ERN/DED Element Name	Payroll-ERN/DED (PTD)	Payroll-ACCUM (PTD)	Previous Payroll-ACCUM (YTD)	Difference Payroll [ERN/DED-ACCUM] PTD
EmployeeLevel		DEDUCTION	KA000200	Child Support Debit	COURTORDER	200.00	200.00	1,200.00	0
EmployeeLevel	SAW	GROSS	KA000200	GROSS Amount	FAD	2,345.00	2,345.00	302.88	0
EmployeeLevel	SAW	GROSS	KA000200	GROSS Amount	PHONE	1,234.00	1,234.00	0.00	0
EmployeeLevel	SAW	GROSS	KA000200	GROSS Amount	REGPAY STDHR	5,833.33	5,833.33	32,261.89	0
EmployeeLevel	SAW	PAYGW	KA000200	PAYGW Amount	MARGINAL TAX	2,457.00	2,457.00	6,482.00	0

Pay Event Employee Report - Sample Output

**Pay Event Employee STP Reconciliation Report**

Pay Entity :KAAUSBI  
 Paygroup :KAMONTHLY  
 Cal Run ID :KA 2022M01

Type	Income Type	Category	Payroll ID	Hire Date	Leave Date	Employee Count	Sub-Category	Payroll [YTD]	STP [YTD]	Difference
Summary	N/A	GROSS	N/A	N/A	N/A	5	GROSS	198,699.95	195,528.01	3171.94
Summary	N/A	LUMPSUM	N/A	N/A	N/A	6	LUMPE	175,144.82	87,572.41	87572.41
Summary	N/A	RFB	N/A	N/A	N/A	5	RFB TAX	54,418.60	0.00	54418.6
Summary	N/A	SUPER	N/A	N/A	N/A	5	OTE	200,496.26	197,324.32	3171.94
Type	Income Type	Category	Payroll ID	Hire Date	Leave Date	Employee Count	Sub-Category	Payroll [YTD]	STP [YTD]	Difference
EmployeeLevel	SAW	GROSS	KA0003000	1987-02-10		N/A	GROSS	29,283.31	29,527.90	-244.59
EmployeeLevel		SUPER	KA0003000	1987-02-10		N/A	OTE	24,127.90	24,372.49	-244.59
EmployeeLevel	SAW	GROSS	KA0004000	1992-02-08		N/A	GROSS	30,916.69	32,166.79	-1250.1
EmployeeLevel		SUPER	KA0004000	1992-02-08		N/A	OTE	26,706.79	27,956.89	-1250.1
EmployeeLevel	SAW	GROSS	KA0005000	1997-05-01		N/A	GROSS	35,583.31	36,749.93	-1166.62
EmployeeLevel		SUPER	KA0005000	1997-05-01		N/A	OTE	36,749.93	37,916.55	-1166.62
EmployeeLevel	SAW	GROSS	KA0006000	1987-10-02		N/A	GROSS	27,416.69	29,916.74	-2500.05
EmployeeLevel		SUPER	KA0006000	1987-10-02		N/A	OTE	24,911.74	27,411.79	-2500.05

**Note**

A red highlight indicates the difference between payroll and STP outputs.

Pay Event Employee Element Detail - Sample Output

Pay Event Employee STP Reconciliation Report Detail									
Pay Entity		:KAAUSBI							
Paygroup		:KAMONTHLY							
Cal Run ID		:KA 2022M01							
Type	Income Type	Category	Payroll ID	Sub-Category	ERN/DED Element Name	Payroll-ERN/DED [PTD]	Payroll-ACCUM [PTD]	Previous Payroll-ACCUM [YTD]	Difference Payroll [ERN/DED-ACCUM] PTD
EmployeeLevel		DEDUCTION	KA0003000	Fees	UNION	9.50	9.50	57.00	0
EmployeeLevel		SUPER	KA0003000	OTE Amount	REGPAY STDHR	4,183.33	4,183.33	25,099.98	0
EmployeeLevel		SUPER	KA0003000	Super Liability	SGCMAN	418.33	418.33	2,088.33	0
EmployeeLevel	SAW	GROSS	KA0003000	Gross Amount	REGPAY STDHR	4,183.33	4,183.33	25,099.98	0
EmployeeLevel	SAW	PAYGW	KA0003000	PAYGW Amount	MARGINAL TAX	1,174.00	1,174.00	7,044.00	0
EmployeeLevel		DEDUCTION	KA0004000	Fees	UNION	9.50	9.50	57.00	0
EmployeeLevel		SUPER	KA0004000	OTE Amount	REGPAY STDHR	4,416.67	4,416.67	26,500.02	0
EmployeeLevel		SUPER	KA0004000	Super Liability	SGCMAN	441.67	441.67	2,191.67	0
EmployeeLevel	SAW	GROSS	KA0004000	Gross Amount	REGPAY STDHR	4,416.67	4,416.67	26,500.02	0
EmployeeLevel	SAW	PAYGW	KA0004000	PAYGW Amount	HELP	43.00	43.00	258.00	0
EmployeeLevel		SUPER	KA0005000	OTE Amount	REGPAY STDHR	5,083.33	5,083.33	30,499.98	0
EmployeeLevel		SUPER	KA0005000	Super Liability	SGCMAN	508.33	508.33	3,166.65	0

## Converting Data from STP 1 to STP 2

The data conversion process converts the data from pay event 2018 format to pay event 2020 format. While this feature is primarily used for update events, it can also be used to report to the Final Pay Event for terminated employees before transitioning to STP Phase 2.

The pay event data in 2020 format is stored in STP Phase-2 staging tables.

Two validation log files will be generated:

- **STP Validation Log:** This validation log includes the conditional validation on two or more tags and for any missing mandatory information. A CSV file is generated with the list, and they are classified as 'error' or 'warning'.

### STP Validation Log

	A	B	C	D	E
1	Pay Entity: KAAUSBI				
2	Tax Year: 2022				
3					
4	Calendar Group Id: KA 2021M12				
5					
6					
7	PAYEVNT				
8	Audit Message	Message Type			
9					
10					
11	PAYEVNTEMP				
12	Emplid	Balance_Group	Audit Message		Message Type
13	KA0004	'000'	Invalid Tax Treatment Code.		ERROR
14	KA0005	'000'	Invalid Tax Treatment Code.		ERROR
15	KA0006	'000'	Invalid Tax Treatment Code.		ERROR

- **Data conversion log for employees:** This log lists employees for whom the data has been converted. This validation log includes details like Employee ID, Balance Group and Calendar Group ID.

### Data conversion log for employees

	A	B	C	D
1	Pay Entity: KAAUSBI			
2	Tax Year: 2022			
3				
4				
5	Employees list			
6	Emplid	Balance Group	Calendar Group ID	
7	KA0009	'000'	'KA 2021M12'	
8	KA0014	'000'	'KA 2021M12'	
9	KA0044	'000'	'KA 2021M12'	

### Note

ATO has mentioned that if the payer is unable to provide the data in line with the Income Stream Collection, then they must use the Update 2018 service to amend the finalised Income Statement. There is no mandatory requirement that data needs to be converted to 2020 format. If a user wishes to submit in the new format, such users can make use of the data conversion process.

Once the data is converted into STP Phase 2 format, customers can review and override (if necessary) the data through the STP 2.0 Update Event AUS page. For more information about STP Phase 2.0 setup, see the [STP Reconciliation Setup AUS Page](#). The update event for the converted data can be submitted in Pay Event 2020 format using the regular process, where the update event date has to be added to the respective employee data, and the file generation process is to be run for generating the update event file.

It is stated by the ATO that Tax Treatment Code is mandatory and should be reported as at run date/time stamp of the Update process. The data conversion process updates the tax treatment code based on the system date. In the XML file generated during an update event, the tax treatment code is updated again based on the date and time stamp of the update action run for the employees for whom the data is converted.

### Special Note for Allowance and Deduction

Follow these guidelines while converting data from STP I to STP II format:

- Subcategories reported in STP I should be replaced with the subcategories reported in STP II.
- Customers are required to update AUS BR DC MAPPING bracket with any custom allowance codes that differ between STP Phase 1 and STP Phase 2.
- The existing bracket [AUS BR RETRO SETUP] has been delivered with a new effective date as 07/01/2000 for accommodating the retro calculations during data conversion.

The search keys GP TEMP001 CHAR and GP TEMP002 CHAR are used to search with Category and Sub-Category. If the allowance category in Phase 1 is 'Other', the three additional search keys GP TEMP003 CHAR, GP TEMP004 CHAR, and GP TEMP005 CHAR are used to search with the description of the sub-category.

Search Keys

Bracket Name | Lookup Rules | **Search Keys/Return Columns** | Data

Element Name AUS BR DC MAPPING STP Data Conversion Mapping Owner PS Non-Mnt

Definition  | 1 of 1 | View All

Effective Date 01/01/2000 Status Active

**Search Columns**

*Search Key 1 Type	Variable	*Element Name - Key 1	GP TEMP001 CHAR
Search Key 2 Type	Variable	*Element Name - Key 2	GP TEMP002 CHAR
Search Key 3 Type	Variable	*Element Name - Key 3	GP TEMP003 CHAR
Search Key 4 Type	Variable	*Element Name - Key 4	GP TEMP004 CHAR
Search Key 5 Type	Variable	*Element Name - Key 5	GP TEMP005 CHAR

**Return Columns**

Return Entry Type 1	Bracket	Element Name - Value 1	AUS BR DC MAPPING
Return Entry Type 2		Element Name - Value 2	
Return Entry Type 3		Element Name - Value 3	
Return Entry Type 4		Element Name - Value 4	
Return Entry Type 5		Element Name - Value 5	
Return Entry Type 6		Element Name - Value 6	
Return Entry Type 7		Element Name - Value 7	
Return Entry Type 8		Element Name - Value 8	

Save | Return to Search | Notify | Add | Update/Display | Include History | Correct History

Bracket Name | Lookup Rules | Search Keys/Return Columns | Data

Since there is a limitation that the number of allowed characters is only 18 for a search key, three fields have been enabled to add the description.

Data

Bracket Name | Lookup Rules | Search Keys/Return Columns | **Data**

Element Name AUS BR DC MAPPING STP Data Conversion Mapping Owner PS Non-Mnt

Definition  | 1 of 1 | View All

Effective Date 01/01/2000 Status Active

**Bracket Search Keys and Return Column Values**

Search Key GP TEMP001 CHAR	Search Key GP TEMP002 CHAR	Search Key GP TEMP003 CHAR	Search Key GP TEMP004 CHAR	Search Key GP TEMP005 CHAR	Return Column AUS BR DC MAPPING		
ALLOWANCE	CAR				CD	+	-
ALLOWANCE	LAUNDRY				LD	+	-
ALLOWANCE	MEALS				MD	+	-
ALLOWANCE	OTHER	FIRSTAID	ALLOWANCE		KN	+	-
ALLOWANCE	TRANSPORT				AD	+	-
ALLOWANCE	TRAVEL				RD	+	-
DEDUCTION	FEES				F	+	-
DEDUCTION	WORKPLACE GIVING				W	+	-

Save | Return to Search | Notify | Add | Update/Display | Include History | Correct History

Bracket Name | Lookup Rules | Search Keys/Return Columns | Data

**Note**

The search keys GP TEMP003 CHAR,GP TEMP004 CHAR, GP TEMP005 CHAR should be populated only when the allowance sub-category is selected as “Other” in STP Phase 1.

## Page Used to Convert Data from STP I to STP II

Page Name	Definition Name	Usage
<a href="#">STP Update/Final Event Data Conversion Page</a>	GPAU_STP_DC_RN	To amend a file using 2020 service that was initially submitted using the 2018 service. Data can be converted for Update Events or Final Pay Events.

## STP Update/Final Event Data Conversion Page

Use the STP Update/Final Event Data Conversion page (GPAU\_STP\_DC\_RN) to amend a file using 2020 service that was initially submitted using the 2018 service. Data can be converted for Update Events or Final Pay Events.

Navigation:

**Global Payroll & Absence Mgmt** , and then **Authority Correspondence** , and then **STP Data Conversion Process**

This example illustrates the Data Conversion Processing for Update Event.

The screenshot shows the 'STP Update/Final Event Data Conversion' page. At the top, there is a breadcrumb trail: '< Process List' followed by 'STP Update/Final Event Data Conversion'. On the right side of the header, there are icons for home, search, notifications, and a settings menu, along with links for 'New Window', 'Help', and 'Personalize Page'. Below the header, the page title 'STP Update/Final Event Data Conversion' is displayed. The main content area includes a 'Run Control ID' field with the value '1', and buttons for 'Report Manager', 'Process Monitor', and 'Run'. The central part of the page is titled 'STP Data Conversion Process' and contains a form with the following fields:
 

- 'Process for Event Type' dropdown menu set to 'Update Event'.
- 'Process by' dropdown menu set to 'Pay Entity'.
- '\*Tax Year' text input field containing '2022'.
- '\*Pay Entity' text input field containing 'KAAUSBI', with a search icon and the text 'Australian Business Institute' to its right.
- 'Calendar Group ID' text input field containing 'KA 2021M12', with a search icon and the text 'KA 2021M12 Monthly' to its right.

This example illustrates the Data Conversion Processing for Final Event.

< Process List
STP Update/Final Event Data Conversion

**STP Update/Final Event Data Conversion**

Run Control ID 1
Report Manager Process Monitor
Run

**STP Data Conversion Process**

Process for Event Type

\*Tax Year

\*Pay Entity

Australian Business Institute

Save
Return to Search
Notify
Add
Update/Display

Field or Control	Description
<b>Process for Event Type</b>	Select whether to run the conversion process for an Update Event or a Final Pay Event. Only the Tax Year and Pay Entity fields are considered if Final Pay Event is selected, as the data needs to be converted for the selected Pay Entity regardless of calendars, other parameters are not taken into account. <b>Note:</b> In the case of final pay event, the conversion process should be run only for the terminated employees prior to transition.
<b>Process by</b>	Select the required value for which the STP data conversion process to be performed. Available options are: <ul style="list-style-type: none"> <li>Pay Entity</li> <li>Employee ID</li> <li>Group List</li> <li>Pay Group</li> <li>Period End Date</li> <li>Streams</li> </ul> These values are enabled based on the run control parameters, whereas Tax Year and Pay Entity are key fields.
<b>Tax Year</b>	The Tax Year for which the data should be converted.
<b>Pay Entity</b>	The Pay Entity for which the data should be converted.
<b>Calendar Group ID</b>	The Calendar Group ID for which the data should be converted.
<b>Employee ID and BAL GRP</b>	Select the unique ID of the employee and balance group for which the conversion process to be run. These fields are displayed only when the value selected in the Process by field is 'Emplid'. <b>Note:</b> These fields are applicable if you want to perform the conversion process for an employee.

Field or Control	Description
<b>Group List ID</b>	Select the required group list ID for which the data conversion process need to be performed. This field is displayed only when the value selected in the Process by field is 'Group List'. <b>Note:</b> This field is applicable if you want to perform the data conversion process for a group of employees.
<b>Period ID and Stream Number</b>	Select the required payroll period and stream for which the data conversion process need to be performed. These fields are displayed only when the value selected in the Process by field is 'Streams'. <b>Note:</b> This field is applicable if you want to perform the data conversion process for a specific payroll stream.

## Updating STP Event AUS

STP Update Event process is used to report changes to employee data previously reported to the ATO. Any changes made to report employee data for the prior financial year must only be submitted through the update event.

Update event must include latest Year to Date (YTD) value for all payments (including each Employment Termination Payment (ETP) by payment date and code) made in the financial year. It is just not sufficient to include only the changed values.

Update Event should not be used to update:

- Employer Total Gross Payments and Total PAYGW Amounts
- Onboarding section (which contains the employee withholding details and declaration)

Employer pay period totals for gross payments and PAYG withholding cannot be included in an update event, as there is no associated payment to the employee when changes are reported through the update event.

### Note

The Update Event and Payee Overrides are using the same component and the values derived from the same set of records. The difference is that Update Event Date field will be displayed when the user selects the Update Event radio button, whereas it is not applicable for Payee Override. Also, Onboarding tab is not editable for Update Event, whereas user can edit the same in case of Payee Override.

This topic discusses how to run STP Update Event process.

## Page Used to Update STP Event Process

Page Name	Definition Name	Usage
<a href="#">Personal Information Page</a>	GPAU_STP_PERS_DTL	To modify the given personal information of an employee after the end of fiscal year.
<a href="#">Wages &amp; Taxation Page</a>	GPAU_STP_WAGES_TAX	To modify the given earnings information of an employee after the end of fiscal year.
<a href="#">Allowances Page</a>	GPAU_STP_ALLOW	To modify the allowance related values of an employee after the end of fiscal year.
<a href="#">Deductions Page</a>	GPAU_STP_DED	To modify the given deductions of an employee after the end of fiscal year.
<a href="#">Super Entitlement Page</a>	GPAU_STP_SUPER_ENT	To modify the superannuation contribution tuple data of an employee after the end of fiscal year.
<a href="#">Onboarding Page</a>	GPAU_STP_ONBRD	To view the given onboarding information of an employee.
<a href="#">STP Payroll Event File AUS Page</a>	GPAU_STP_RUNCTL	To generate Pay Event or Update Event file.

As a user, follow the given steps to update STP Event:

- Select the Employee for whom the update event is to be executed.
- Update Event should always be submitted against the last Pay Event
- Add a new row by clicking “+”
- Select the Update Event Radio Button
- Update Event Date – This field is enabled once the user selects Update Event Radio Button. This is a mandatory field and the same is used as an indicator to generate the Update Event File.
- Incorporate the necessary correction or updates to the respective Personal and Payroll fields and save the page once the required data is entered.

### Note

Any data entered using this component will not cascade to Payroll, user need to take care of the same.

No negative values will be allowed to enter, as Year to Date cannot be negative.

**Note**

Update STP Event process is not intended to be used for un-finalized payrolls. It is recommended to correct the results within the payroll as long as the payroll has not been finalized.

## Personal Information Page

Use the Personal Information page (GPAU\_STP\_PERS\_DTL) to update the personal information of the employee. Based on the selected calendar group id for which the amendments to be done, the system populates the values submitted in the original file.

Navigation:

**Global Payroll & Absence Mgmt** , and then **Payee Data** , and then **Single Touch Payroll AUS** , and then **STP Update Event AUS** , and then **Personal Information**

This example illustrates the Personal Information Page.

**Personal Information**
Wages & Taxation
Allowances
Deductions
Super Entitlement
Onboarding

Jane Taylor

Tax Year 2019

Empl ID KA0001

Balance Group Nbr 000

Pay Entity KAAUSBI

Pay Group KAMONTHLY

Calendar Group ID KA 2018M08

**Payee Override / Update Event Information** 2 of 2 | View All

Payee Override
  Update Event
 \*Update Event Date

**Personal Information**

**Employee Name**

Family Name  Other Name

First Name  Hire Date  Leave Date

Date of Birth

**Employee Address**

Address 1

Address 2

City  Email Address

Postal Code  Phone Number

Country  Australia

State  New South Wales

**Payroll Event**

Final Event Indicator

Field or Control	Description
<b>Personal Information</b>	Employee details are fetched from PS_GPAU_STP_HR_STG table and if user updates any data, the same will consider while reporting Update Event.

PeopleSoft Global Payroll for Australia  
G49606-01  
Copyright © 1988, 2026, Oracle and/or its affiliates.

May 11, 2026  
Page 62 of 69

---

Field or Control	Description
<b>Final Event Indicator</b>	This is reported per employee, per payroll ID as part of the employee record. User may submit via pay event or through update event. Users need to select the check box to report this indicator in output file.

---

## Wages & Taxation Page

Use the Wages & Taxation page (GPAU\_STP\_WAGES\_TAX) to update the earnings information of the employee. Based on the selected calendar group id for which the amendments to be done, the system populates the values submitted in the original file.

Navigation:

**Global Payroll & Absence Mgmt** , and then **Payee Data** , and then **Single Touch Payroll AUS** , and then **STP Update Event AUS** , and then **Wages & Taxation**

This example illustrates the Wages & Taxation Page.

Personal Information **Wages & Taxation** Allowances Deductions Super Entitlement Onboarding

Jane Taylor Empl ID KA0001 Pay Entity KAAUSBI Calendar Group ID KA 2017M07  
Tax Year 2018 Balance Group Nbr 000 Pay Group KAMONTHLY

Payee Override / Update Event Information 1 of 1 | View All

Payee Override  Update Event Version 0

**Individual Non Business**

Gross Payments	5833.33	CDEP Payments	0.00
PAYGW	1512.00	Exempt Foreign Income	0.00

**Voluntary Agreement**

Gross Payments	0.00	PAYGW	0.00
----------------	------	-------	------

**Business and Personal Services Income**

Gross Payments	0.00	PAYGW	0.00
----------------	------	-------	------

**Other Specified**

Gross Payments	0.00	PAYGW	0.00
----------------	------	-------	------

**Joint Petroleum Development Area**

Gross Payments	0.00	FEI Foreign Tax Paid	0.00
FEI JDP A PAYGW	0.00		

**Working Holiday Maker**

Gross Payments	<input type="text" value="0.00"/>	PAYGW	<input type="text" value="0.00"/>
----------------	-----------------------------------	-------	-----------------------------------

**Foreign Employment Income**

Gross Payments	<input type="text" value="0.00"/>	FEI Foreign Tax Paid	<input type="text" value="0.00"/>
FEI PAYGW	<input type="text" value="0.00"/>		

**Reportable Fringe Benefits**

Taxable	<input type="text" value="0.00"/>	Exempt	<input type="text" value="0.00"/>
---------	-----------------------------------	--------	-----------------------------------

**Lump Sum Payments**

Lumpsum Type	<input type="text"/>	Lump Sum A	<input type="text" value="0.00"/>
Lump Sum B	<input type="text" value="0.00"/>	Lump Sum D	<input type="text" value="0.00"/>
Lump Sum E	<input type="text" value="0.00"/>		

**Employee Termination Payments**

1-1 of 1 | View All

	ETP Code	Payment Date	Tax Free Amount	Taxable Amount	PAYGW Amount		
1	<input type="text"/>	<input type="text"/>	0.00	0.00	0.00	+	-

Field or Control	Description
<b>Employee Termination Payments</b>	Employee Termination Payments Codes and Values can iterate up to a maximum of 25 times. Thus, once the user made use of 25 field values, add button will disable from the grid.

## Allowances Page

Use the Allowances page (GPAU\_STP\_ALLOW) to update the allowance related information of the employee. Based on the selected calendar group id for which the amendments to be done, the system populates the values submitted in the original file.

Navigation:

**Global Payroll & Absence Mgmt** , and then **Payee Data** , and then **Single Touch Payroll AUS** , and then **STP Update Event AUS** , and then **Allowances**

This example illustrates the Allowances Page.

Personal Information
Wages & Taxation
Allowances
Deductions
Super Entitlement
Onboarding

Jane Taylor

Tax Year 2018

Empl ID KA0001

Balance Group Nbr 000

Pay Entity KAAUSBI

Pay Group KAMONTHLY

Calendar Group ID KA 2017M07

Payee Override / Update Event Information 1 of 1 | View All

Payee Override    
  Update Event    
 Version 0

**Allowances**

	Allowance Type	Description	Amount
1			0.00

**Note**

Employee Allowance Codes and values can be iterated to maximum of 30 times. Thus, once the user enters 30 field values, disables the add button from the grid. The Allowances information are derived from PS\_GPAU\_STP\_ALLOW record.

## Deductions Page

Use the Deductions page (GPAU\_STP\_DED) to update deductions such as Union Fees & Workplace Giving of the employee. Based on the selected calendar group id for which the amendments to be done, the system populates the values submitted in the original file.

Navigation:

**Global Payroll & Absence Mgmt** , and then **Payee Data** , and then **Single Touch Payroll AUS** , and then **STP Update Event AUS** , and then **Deductions**

This example illustrates the Deductions Page.

Personal Information
Wages & Taxation
Allowances
Deductions
Super Entitlement
Onboarding

<u>Jane Taylor</u>	Empl ID KA0001	Pay Entity KAAUSBI	Calendar Group ID KA 2018M08
Tax Year 2019	Balance Group Nbr 000	Pay Group KAMONTHLY	

Payee Override / Update Event Information
2 of 2
View All

Payee Override
 Update Event
Update Event Date

Deductions

	Deduction Code	Deduction Type	Description	Amount		
1	Fees	Fees	Fees	19.00	+	-

**Note**

The page can hold maximum of 4-deduction categories. The Employee deduction codes and Values and can be iterated up to a maximum of four times. Thus, once the user enters four values, the add button will be disabled from the grid. The Deduction information is derived from PS\_GPAU\_STP\_DED record.

## Super Entitlement Page

Use the Super Entitlement page (GPAU\_STP\_SUPER\_ENT) to update Superannuation Contribution Tuple data. Based on the selected calendar group id for which the amendments to be done, the system populates the values submitted in the original file.

Navigation:

**Global Payroll & Absence Mgmt** , and then **Payee Data** , and then **Single Touch Payroll AUS** , and then **STP Update Event AUS** , and then **Super Entitlement**

This example illustrates the Super Entitlement Page.



# STP Payroll Event File AUS Page

Use the STP Payroll Event File AUS page (GPAU\_STP\_RUNCTL) to generate or update Pay Event files. For more information on how to generate pay event file, see [Generating Pay Event File](#)

Navigation:

**Global Payroll & Absence Mgmt** , and then **Payee Data**, and then **Single Touch Payroll AUS**, and then **STP Update Event AUS**

This example illustrates the fields and controls on the STP Payroll Event File AUS Page. You can find definitions for the fields and controls later on this page.

## STP Payroll Event File AUS

Run Control ID 1212      Report Manager      Process Monitor      **Run**

---

**STP Selection Parameters**

\*Tax Year

\*STP File Type

\*Pay Entity       Australian Business Institute

\*Run Type

XML with Root Node

---

**STP Pay Date Parameters**

Pay Group       Monthly Pay Group

\*Update Event Date

\*Reporting Party       \*Declaration

**STP Pay Run Parameters**

Final Event Indicator

---

**Authorization**

I am notifying the ATO that:

- SuperChoice provides my business with lodgement transaction services; and
- my business, for the purpose of its transactions with ATO via the SBR channel, sends (and receives) those transactions to (and from) the ATO via SuperChoice.

I declare the information transmitted in this payroll report is true and correct and I am authorised to make this declaration.

Acknowledgement

Field or Control	Description
<b>Tax Year</b>	Enter the Fiscal Year for which the update event is processed. For example, enter, "2017" for 2016-17 Tax Year.
<b>STP File Type</b>	Select the STP file type. Available options are: <ul style="list-style-type: none"> <li>• Pay Event</li> <li>• Update Event</li> </ul>
<b>Pay Entity</b>	Select the pay entity, for which the employer would like to generate Payroll Event (PAYEVNT & PAYEVNTEMP).

Field or Control	Description
<b>Run Type</b>	Select the Run Type. Available options are: <ul style="list-style-type: none"> <li>• Test: Use the Test option for testing files to ensure they are complied with the reporting norms before running the final submission.</li> <li>• Production: Use the Production option when you are submitting the final file for payroll processing.</li> </ul>
<b>XML with Root Node</b>	Select the checkbox if you want to generate a temporary XML file with Root Node, which can be viewed in a browser, with the ability to export to excel. <p><b>Note:</b> This option is for easier validation. The Final XML file to be submitted to the authorities should be generated without a Root node, which is a non-standard XML structure and thereby does not open properly in a normal browser; instead, the file can be opened and reviewed in text editors, such as Notepad, Notepad++ or Text Pad.</p>
<b>Pay Group</b>	Select the paygroup if you want to generate the file for a particular pay group. <p>For example, if there are pay groups for Weekly and Monthly, employers would be able to generate the separate file for each pay group.</p>
<b>Update Event Date</b>	Select the date on which the update event is carried out for the employees.
<b>Reporting Party</b>	Select the Reporting Party. Available options are: <ul style="list-style-type: none"> <li>• Payer/Employer</li> <li>• Intermediary</li> </ul>
<b>Declaration</b>	Select the option as True or False to indicate whether the terms stated in the Declaration Text have been accepted or declined.
<b>Final Event Indicator</b>	An employer is required to make a declaration to the ATO, that they have provided all the information for each employee for a financial year, by providing the finalization indicator as a part of an employee's Single Touch Payroll report. Select this check box if you want to include this indicator in the final output.

# 7

## Setting Up Banking and Recipient Processing

### Understanding Banking and Recipient Processing Setup

Before you run banking and recipient processes, you need to set up additional source bank details and link the source banks to debit types. Additional setup is also required on an ongoing basis; for example, you need to link payees to recipients and additional recipient information for reporting and collection of commissions that are payable.

### Entering Additional Source Bank Information

To set up source bank information for Australian banking, use the Source Bank Accounts (GPAU\_SRC\_BANK) component.

In addition to the standard Global Payroll source bank account information page, it includes a page for electronic funds transfer (EFT) information and trace bank information.

### Page Used to Enter Additional Source Bank Information

Page Name	Definition Name	Usage
<a href="#">Source Bank Accounts AUS Page</a>	GPAU_SRC_BANK_EXT	Enter EFT and trace bank information.

### Source Bank Accounts AUS Page

Use the Source Bank Accounts AUS Page (GPAU\_SRC\_BANK\_EXT) to enter EFT and trace bank information.

Navigation:

**Set Up HCM**, and then **Product Related**, and then **Global Payroll & Absence Mgmt**, and then **Banking**, and then **Source Bank Accounts AUS**, and then **Source Bank Accounts AUS**

This example illustrates the fields and controls on the Source Bank Accounts AUS. You can find definitions for the fields and controls later on this page.

### Source Bank Accounts AUS

Source Bank ID ANZ01                      Description Salaried Clearing Account(AUS)

**User and Trace Details**

\*EFT User No

\*EFT User Name

\*Trace Bank Code

Description Salaried Clearing Account(AUS)

Field or Control	Description
<b>EFT User No</b> (electronic funds transfer user number)	Enter the EFT user number, which the bank supplies.
<b>EFT User Name</b>	Enter the EFT user name, which the bank supplies.
<b>Trace Bank Code</b>	Enter the source bank ID for the bank to use for transaction tracing. Each source bank has its own branch and account details.

## Setting Up Multiple Source Banks by Debit Type

To set up different source banks, use the Pay Entity Source Bank (GPAU\_PYENT\_SBNK) component.

In Global Payroll, you can set up different source banks for each organizational unit such as pay entity, department, establishment, or pay group. Set this up on the Source Bank Link page of the Pay Entity component.

For Australian banking, you can set up different source banks for each drawing purpose. The drawing purpose is defined as a debit type (the debit types are Group Tax, Net Payment, and Recipient).

Instead of setting up a source bank on the Source Bank Link page—where you link source banks to organizational units—access the Pay Entity/Source Bank AUS page. On that page, select **Source Bank Override**, and enter multiple source banks by debit type.

## Pages Used to Set Up Multiple Source Banks by Debit Type

Page Name	Definition Name	Usage
<a href="#">Pay Entity/Source Bank Page</a>	GPAU_PE_SBANK_OVRD	Access the Source Bank Override page.
<a href="#">Source Bank Override Page</a>	GPAU_PE_SBANK_SEC	Link source banks to debit types.

## Pay Entity/Source Bank Page

Use the Pay Entity/Source Bank page (GPAU\_PE\_SBANK\_OVRD) to access the Source Bank Override page.

Navigation:

**Set Up HCM**, and then **Product Related**, and then **Global Payroll & Absence Mgmt**, and then **Framework**, and then **Organizational**, and then **Pay Entity Source Bank AUS**, and then **Pay Entity Source Bank AUS**

This example illustrates the fields and controls on the Pay Entity Source Bank AUS page. You can find definitions for the fields and controls later on this page.

### Pay Entity Source Bank AUS

Pay Entity KAAUSBI

Organization Link Option Pay Group

Definition Find | View All First 1 of 1 Last

Effective Date 01/01/2000

Organization Link List		Personalize   Find    First 1-2 of 2 Last	
Organization Unit	Description	Source Bank ID	Source Bank Override
KAMONTHLY	Monthly Pay Group	KA01	Source Bank Override
KAWEEKLY	Weekly Pay Group	KA04	Source Bank Override

The page displays information from the Source Bank Link page. Click the **Source Bank Override** link to access the Source Bank Override page.

## Source Bank Override Page

Use the Source Bank Override page (GPAU\_PE\_SBANK\_SEC) to link source banks to debit types.

Navigation:

Click the **Source Bank Override** link on the Pay Entity/Source Bank page.

This example illustrates the fields and controls on the Source Bank Override page. You can find definitions for the fields and controls later on this page.

### Source Bank Override

Pay Entity KAAUSBI      Organization Unit KAMONTHLY

Effective Date 01/01/2000

Source Bank Debit Type Personalize | Find | First 1-2 of 2 Last

	*Debit Type	*Source Bank ID	Description		
1	Group Tax <span style="float: right;">▼</span>	KA03 <span style="float: right;">🔍</span>	Salary Group Tax Remitt (AUS)	+	-
2	Recipient <span style="float: right;">▼</span>	KA02 <span style="float: right;">🔍</span>	ANZ Recipient Account (AUS)	+	-

---

Field or Control	Description
<b>Debit Type</b>	Enter a debit type of <i>Net Pmt</i> (net payment), <i>Group Tax</i> , or <i>Recipient</i>
<b>Source Bank ID</b>	Enter the ID of the source bank that you want to use to pay the debit type.

---

# 8

## Setting Up Payslips

### Understanding Payslip Setup

The Payslip feature enables you to control the content and format of payslips. Because you can override templates at lower levels, you do not have to create multiple templates to cover every payslip scenario.

#### Related Topics

- [Overriding Payslip Delivery Options](#)  
The default delivery option for all payslips is the internal or external address that you select when you define the payslip template. You can set an effective-dated override of that delivery option at the payee level. Select **Global Payroll & Absence Mgmt**, and then **Payee Data**, and then **Payslips**, and then **Payslip Delivery Option AUS**.
- [Description of Processes in Payslip Job](#)  
The Payslip page launches a Job (GPAUPYSL) containing two processes in sequence:

### Creating Payslip Templates and Messages

To set up payslip templates and messages, use the Templates AUS (GPAU\_PSLP\_SETUP) and Messages AUS (GPAU\_PSLP\_MSG) components.

This topic discusses ways to create payslip templates and messages.

### Pages Used to Create Payslip Templates and Messages

Page Name	Definition Name	Usage
<a href="#">Payslip Setup Page</a>	GPAU_PSLP	Set up delivery and print exclusion options, column headings (labels) and column content (rows of accumulators)
<a href="#">Earnings and Deduction Page</a>	GPAU_PSLP1	Create sections of earnings and deductions, select description options, and set the element components that the payslip displays.
Absence Details Page	GPAU_PSLP2	Enter a sequence number and element name, and select the description type. The system extracts the balance of each entitlement or pro rata absence element and includes it on the payslip.

Page Name	Definition Name	Usage
<a href="#">Messages AUS Page</a>	GPAU_PSLP_EXT	Create messages to appear on payslips for a particular calendar group. You can control which payslips display the messages.

## Payslip Setup Page

Use the Payslip Setup page (GPAU\_PSLP) to set up delivery and print exclusion options, column headings (labels) and column content (rows of accumulators).

Navigation:

**Set Up HCM**, and then **Product Related**, and then **Global Payroll & Absence Mgmt**, and then **Payslips**, and then **Templates AUS**

This example illustrates the fields and controls on the Payslip Setup page. You can find definitions for the fields and controls later on this page.

Field or Control	Description
<b>Payslip ID</b>	Displays the payslip ID. A template can be attached to multiple pay groups. <b>Note:</b> Only one template can be attached to a particular pay group at a time.
<b>Delivery Option</b>	Select an address to receive printed payslips. It can be an internal address of <i>Department</i> or <i>Location</i> , or an external address of <i>Home Address</i> or <i>Mail Address</i> as recorded on the payee's personal data record. You can override the selection made here on the Payee Payslip Overrides page. Because this selection is effective-dated, you can override the delivery option for a period of time, if necessary.

Field or Control	Description
<b>Exclude Printing</b>	<p>Select either <i>Department</i> or <i>Location</i> to exclude departments or locations from the payslip print run. The corresponding link becomes active, so you can select departments or locations.</p> <p>You can override the exclusion on the Print Payslips page before you run the print program.</p> <p><b>Note:</b> If you enter a particular pay entity for the print option on the Print Payslips page and you have excluded a location within the pay entity, the payslips are <i>not</i> printed.</p>

### Accumulator Labels

Field or Control	Description
<b>Column 1 to Column 6</b>	Enter the labels that appear on the printed payslips as the column headings for the accumulators. These column headings appear in the payslip region under the heading Pay Summary.

### Accumulator Elements: Accumulators 1 to 3 Tab

Field or Control	Description
<b>Sequence</b>	Enter a sequence number to set the order in which the accumulators appear. The accumulators appear in ascending order with the lowest number first.
<b>Description</b>	Enter a description of each accumulator row.
<b>Accumulator 1 to Accumulator 3</b>	<p>Select the accumulators that appear in the corresponding column.</p> <p>For example, suppose that you enter <i>Current</i> and <i>YTD</i> as the descriptions for accumulators 1 and 2. To also display quarter-to-date accumulated amounts, create a new row, enter the description <i>QTD</i>, and then select the accumulators that correlate to the columns headings.</p>

### Accumulator Elements: Accumulators 4 to 6 Tab

Field or Control	Description
<b>Accumulator 4 to Accumulator 6</b>	Set up accumulators 4 to 6. There are no <b>Sequence</b> and <b>Description</b> fields because the same sequence number and description apply to all six accumulators in the row.

This diagram shows how column numbers, sequences, and accumulator numbers appear on the printed payslip.

	Column 1 Label	Column 2 Label	Column 3 Label	Continued
Seq 1 Description	Accum 1, Seq 1	Accum 2, Seq 1	Accum 3, Seq 1	
Seq 2 Description	Accum 1, Seq 2	Accum 2, Seq 2	Accum 3, Seq 2	
Seq 3 Description	Accum 1, Seq 3	Accum 2, Seq 3	Accum 3, Seq 3	
Continued	.	.	.	

## Earnings and Deduction Page

Use the Earnings and Deduction page (GPAU\_PSLP1) to create sections of earnings and deductions, select description options, and set the element components that the payslip displays.

Navigation:

**Set Up HCM**, and then **Product Related**, and then **Global Payroll & Absence Mgmt**, and then **Payslips**, and then **Templates AUS**, and then **Earnings and Deductions**

This example illustrates the fields and controls on the Earnings and Deduction page. You can find definitions for the fields and controls later on this page.

### Earnings and Deductions Section Setup

Field or Control	Description
<b>Description</b>	Descriptions appear as section headings under the Payment Details heading on the payslip.

### Element Details Tab

Field or Control	Description
<b>Display YTD Units</b> and <b>Display YTD Amount</b>	Select these check boxes to have the YTD units and amounts for each element appear in the Payment Details region under the heading Year to Date Values.
<b>Display Membership #</b>	Select to display the recipient's membership ID in the Description region.

### Element Components Tab

Field or Control	Description
<b>Description Type</b>	<p>Select the type of description to appear for each earnings or deduction row in the Payment Details region of the payslip. Select from the following values:</p> <p><i>Custom:</i> A text box appears for you to enter a description.</p> <p><i>Description:</i> The element's description appears as entered on the element's name page in its component.</p> <p><i>Element Name:</i> The element's name appears from its name page in its component. It also appears on the Elements Details tab.</p> <p><i>Recipient Name:</i> The name of the recipient appears. Select this option to display the name of the superannuation fund.</p>
<b>Print Unit, Base, Rate, and Percentage</b>	<p>Select the components of the element's calculation rule that you want to display for each earning or deduction in the sections.</p> <p>You can select only the components in the element's calculation rule. For example, for an earnings with calculation rule Unit × Rate, only the <b>Unit</b> and <b>Rate</b> check boxes are available.</p> <p><b>Note:</b> Amounts are always displayed.</p>

## Messages AUS Page

Use the Messages AUS page (GPAU\_PSLP\_EXT) to create messages to appear on payslips for a particular calendar group. You can control which payslips display the messages.

Navigation:

**Set Up HCM**, and then **Product Related**, and then **Global Payroll & Absence Mgmt**, and then **Payslips**, and then **Define Payslip Messages AUS**

This example illustrates the fields and controls on the Messages AUS page. You can find definitions for the fields and controls later on this page.

The screenshot shows the 'Messages AUS' page interface. At the top, it displays 'Calendar Group ID KAM04M05\_OFF1' and 'Off Cycle Group 1'. Below this is a 'Definition' section with a search bar and navigation controls (First, 1 of 1, Last). The main form contains the following fields:

- \*Message Number: A text input field.
- \*Message Level: A dropdown menu currently set to 'All'.
- Group ID: A text input field.
- Group List ID: A text input field.
- Message: A large text area for entering the message content.

Field or Control	Description
<b>Message Number</b>	Enter a message ID to indicate the message that is appropriate for the payees. The system uses arrays, formulas, and variables to determine the correct message.
<b>Message Level</b>	Select from the following values: <i>All:</i> All payees identified in the calendar group. <i>Group Build:</i> All payees included in a group built using the Group Build – Group Definition feature, which you access by selecting <b>Set Up HCM</b> , and then <b>Common Definitions</b> , and then <b>Group Build</b> . If you select this option, enter a group in the <b>Group ID</b> field. <i>Group List:</i> All payees in a list built using the Group List feature. If you select this option, enter a group in the <b>Group List ID</b> field.
<b>Message</b>	Enter the text of the message to appear on selected payslips.

## Attaching Payslip Templates to Pay Groups

Attach a payslip template to a pay group by using the Pay Groups AUS page. A pay group can have only one payslip attached at a time; however, a particular template can be attached to multiple pay groups.

# 9

## Defining Earnings

### Understanding Earnings

The PeopleSoft system provides a number of delivered earnings to demonstrate the flexibility of Global Payroll rules and to meet common processing requirements, such as the automatic generation of a payback deduction for specified earnings.

#### Note

The **User Key 2** field on the Earnings Accumulators page and Deduction Accumulators page for all earnings and deductions is AUS VR BALGRP ID. Use balance group IDs to maintain separate employee balances. Set an employee's balance group in the JOB\_DATA2 table. The balance group number must be manually incremented if you are required to record separate balances within a financial year.

#### Related Topics

- PeopleSoft Human Resources Administer Workforce: (Classic) Adding Organizational Instances
- PeopleSoft Human Resources Administer Workforce: Hiring Job Applicants
- PeopleSoft Human Resources Administer Workforce: Adding and Reviewing Organizational Relationships

### Delivered Earnings Elements

In the following table, the first column combines the earning name and description. The code (*gc*) in a row indicates that the earning element has a generation control. The code (*po*) indicates a post-processing formula, and the code (*pr*) indicates a pre-processing formula. The other four columns indicate the earning calculation rule of Unit × Rate, Unit × Rate × Percent, and Amount. (None use Base × %.) The formulas for some of the earnings codes are discussed in further detail following the table. The code (*sy*) stands for *system element*.

Name and Description	Unit	Rate	%	Amount
<i>Regular Pay</i>				
REGPAY HRLY Regular hourly payment	Payee Level	HOURLY RT (sy)		
REGPAY STDHR Regular std hourly pay (gc) (pr)	ERN FM REDU REGHRS	HOURLY RT (sy)		

Name and Description	Unit	Rate	%	Amount
<i>Overtime</i>				
OT1.5 Overtime 1.5	Payee Level	HOURLY RT (sy)	150	
OT2.0 Overtime 2.0	Payee Level	HOURLY RT (sy)	200	
OT2.5 Overtime 2.5	Payee Level	HOURLY RT (sy)	250	
OT3.0 Overtime 3.0	Payee Level	HOURLY RT (sy)	300	
<i>Shifts</i>				
SHFAM Shift Loading Morning (gc)	Payee Level	HOURLY RT (sy)	10	
SHFPM Shift Loading Afternoon (gc)	Payee Level	HOURLY RT (sy)	15	
SHFNT1 Shift Night Loading (gc)	Payee Level	HOURLY RT (sy)	30	
SHFNT2 Shift loading night (gc)	Payee Level	HOURLY RT (sy)	130	
<i>Allowances</i>				
DOG Dog	Payee Level	10		
ONCALL On Call allowance (gc) (po)	Payee Level	ERN FM HOURLY RT		
MEAL Meal	Payee Level	12		
FAD First Aid Allowance (gc)				11.65
PHONE Phone allowance (gc)				75 / period
CAR Car Allowance (gc) (po)				500 / month
STRESS Stress allowance	ERN FM REG UNIT	Payee Level	100	
PRDBON Product Bonus (gc) (po)				4000 / year (A)

Name and Description	Unit	Rate	%	Amount
<i>Miscellaneous</i>				
TRANS ADV Advance Payment Example				Payee Level
BONUS Bonus				Payee Level
RETRO12MTH Retro - Previous 12 Months				Payee Level
REDUNDANCY Redundancy				Payee Level
INVALIDITY Invalidity				Payee Level
EX GRATIA Ex Gratia				Payee Level
PAY IN LIEU Pay in Lieu of Notice				Payee Level
<i>Leave (Absence)</i>				
ANN Annual leave	Payee Level	HOURLY RT (sy)		
ANNRA Ann Lve rolling average	Payee Level	ERN FM ROLL AVG		
LVLN Leave Loading	Payee Level	HOURLY RT (sy)	17.5	
LWOP Leave without pay	Payee Level	AUS VR NUM VAL 0		
PPL Paid parental leave	Payee Level			Payee Level
SCK Sick Leave	Payee Level	HOURLY RT (sy)		
LSL Long Service Leave	Payee Level	HOURLY RT (sy)		
OTHLV Other Leave	Payee Level	HOURLY RT (sy)		
PUB Public holiday (gc)	ERN FM PUB UNIT	HOURLY RT (sy)		
<i>Termination</i>				

Name and Description	Unit	Rate	%	Amount
AL MARGINAL Annual Leave - Marginal (Term) (gc)	TER FM AL BAL HRS	TER FM HOURLY RATE		
AL MARGIN DY Ann Lve - Marginal (Term Days) (gc)	TER FM AL BAL DYS	TER FM DAILY RATE		
LSL MARGINAL LSL - Marginal (Term)	TER VR LS MARGINAL	TER FM DAILY RATE		
LL MARGINAL Leave Loading - Marginal (Term) (gc)	TER FM LL BAL HRS	TER FM HOURLY RATE	17.5	
LL MARGIN DY Leave Load on Term (Days-MAR) (gc)	TER FM LL BAL DYS	TER FM DAILY RATE	17.5	
ETP TAX ETP - Taxable				TER FM ETP PST83
ETP NONTAX ETP - Non Taxable				TER FM ETP PRE83
AL LUMP A Annual Leave - Lump Sum A (gc)	TER FM AL BAL HRS	TER FM HOURLY RATE		
AL LUMPA DY Ann Lve Lump sum A (Term Days)	TER FM AL BAL DYS	TER FM DAILY RATE		
LSL LUMP A LSL - Lump Sum A	TER VR LS LUMPA	TER FM DAILY RATE		
LL LUMP A Leave Loading - Lump Sum A (gc)	TER FM LL BAL HRS	TER FM HOURLY RATE	17.5	
LL LUMPA DY Leave Load on Term (Days-LSA) (gc)	TER FM LL BAL DYS	TER FM DAILY RATE	17.5	
LSL LUMP B LSL - Lump Sum B	TER VR LS LUMPB	TER FM DAILY RATE		
TERM LUMP D Termination - Lump Sum D				TER FM LUMPD
INV POST 94 Invalidity Post 94 Component				TER FM INV POST94

Name and Description	Unit	Rate	%	Amount
<i>Retro</i>				
RTO_ANN Annual Leave - Retro	Payee Level	Payee Level		
RTO_ANNRA Annual Rolling Average - Retro	Payee Level	Payee Level		
RTO_LSL Long Service Leave - Retro	Payee Level	Payee Level		
RTO_LWOP Leave w/o Pay - Retro	Payee Level	Payee Level		
RTO_OTH_LVE Other Leave - Retro	Payee Level	Payee Level		
RTO_PUB_HOL Public Holiday - Retro	Payee Level	Payee Level		
RTO_SCK_LVE Sick Leave - Retro	Payee Level	Payee Level		
RTO_SHFNT2 Night Shift 2 - Retro	Payee Level	Payee Level		

There are four earnings specifically relating to salary packaging, and they all start with the letters *SP*.

See [.Understanding Monitoring Salary Package ExpenditureUpdating Expenditure Data for Employee Salary PackagesReviewing Salary Package ExpendituresReviewing Salary Package Expenditures](#)

There are ten earnings specifically relating to leave liability costing for the General Ledger Interface. They all start with the letters *LIAB*.

There are four earnings specifically relating to Time and Labor costings. They are dummy codes used by Time and Labour, and they all start with the letters *TL*.

## Calculating Regular Pay

There are two delivered earnings elements for regular pay, REGPAY HRLY and REGPAY STDHR.

### REGPAY HRLY

The REGPAY HRLY calculation rule is Unit × Rate, where:

Unit = Payee level

Rate = System element HOURLY RT

### REGPAY STDHR

The REGPAY STDHR calculation rule is  $\text{Unit} \times \text{Rate}$ , where:

Unit = Formula ERN FM REDU REGHRS

Rate = System element HOURLY RT

The unit formula subtracts the reducing hours (in ERN AC REDUCE HRS) from the prorated regular hours (in ERN VR REGPAY HRS). The system prorates the regular hours using the earnings pre-process formula ERN FM CALC REGHRS.

Formula ERN FM REGSTD UNIT calculates the regular hours for the period based on the payee's standard hours and work period entered on the Job Information page. The formula ERN FM CALC REGHRS prorates these hours.

## Calculating Overtime Earnings

There are four overtime earnings for 1.5, 2.0, 2.5 and 3.0 time. Each has a calculation rule of  $\text{Unit} \times \text{Rate} \times \text{Percent}$ , where:

Unit = Payee level

Rate = System element HOURLY RT

Percent = 150, 200, 250, or 300

## Calculating Shift Earnings

There are four shift earnings. Each has a calculation rule of  $\text{Unit} \times \text{Rate} \times \text{Percent}$ , where:

Unit = Payee level

Rate = System element HOURLY RT

Percent = 10, 30, 15, or 130

The earnings element SHFNT2 with 130 percent appears in the LEAVE EARNINGS section because—as with the leave earnings codes—it reduces regular hours.

## Calculating Minimum and Maximum Hourly Rates and Earnings Limits

The ONCALL earning element demonstrates minimum and maximum hourly rates, and a yearly limit PRDBON demonstrates a quarterly limit.

## Checking the Minimum and Maximum Hourly Rate

The ONCALL earning element uses a formula-driven minimum and maximum hourly rate-check and a post-process formula to determine if the payment of ONCALL causes earnings to exceed an annual limit.

The calculation rule for ONCALL is  $\text{Unit} \times \text{Rate}$ , where:

Unit = Payee level

Rate = Formula ERN FM HOURLY RT

When you assign the earnings element or enter it as positive input, the system checks the payee's hourly rate in the Job record in Human Resources to resolve the earnings. It then takes one of the following actions:

- If the hourly rate is less than the value set in variable ERN VR HR RT MIN, then the system pays ONCALL at the value of the variable.
- If the hourly rate is more than the minimum but less than the maximum set in variable ERN VR HR RT MAX, then the system pays ONCALL at the hourly rate from the Job record.
- If the hourly rate is more than the value set in variable ERN VR HR RT MAX, then the system pays ONCALL at the value of the variable.

Here is an example. Suppose that the minimum is 50, and the maximum is 70.

Hourly Rate in Job Record	ONCALL Hourly Rate Paid
1 to 49.99 (that is, less than 50)	50 (minimum)
50 to 70	50 to 70 (Job rate)
71.01 or more (that is, greater than 70)	70 (maximum)

You can set the variables values on the Supporting Element Override page in the earnings components.

## Checking the Maximum Yearly Earnings Limit

To set a yearly limit (or ceiling) on an earning element, you can set the limit in LIM VR YTD LIMIT. The ONCALL earning element is set up for this control.

After the system determines the value of ONCALL for the period, the post-process formula LIM FM ONCALL adds the value of the year-to-date accumulator for ONCALL with the current amount and any additional pay. Here is an example:

Accumulator YTD balance = 1000

Current earning amount = 50

Additional earning amount = 0

Yearly limit = 1010

ONCALL\_FYTD + CURR AMT VAL + ADD VR ADDL AMT = New accumulator balance (if paid)

1000 + 50 + 0 = 1050 (new balance)

It then compares that new balance with LIM VR YTD LIMIT. If the balance exceeds the limit, the system calculates by how much it would exceed the limit if paid.

New balance – Limit = Excess amount

1050 – 1010 = 40

It then subtracts the excess amount from the current amount, reducing it to the maximum that can be paid during the current period without exceeding the limit.

(CURR AMT VAL + ADDL AMT VAL) – LIM VR OVER LIMIT = Amount to pay during the period

$$50 - 40 = 10$$

You can set other limits for other frequencies by using a formula that compares the total paid with the frequency limits for the earnings.

## Checking the Maximum Quarterly Earnings Limit

You can set an upper limit on an earning so that no more than that amount is paid in a particular accumulation period. The PRDBON (product bonus) earning element is set up with this control. It is set up to have a quarterly limit. You set the limit in LIM VR QTD LIMIT.

After the system calculates the PRDBON amount for the pay period, the post-process formula LIM FM PRDBON adds the value to the quarter-to-date accumulator and compares the total to the limit that you have set. If paying the earnings would exceed the limit for the quarter, the system pays only up to the limit.

The PRDBON calculation rule is Amount, where:

$$\text{Amount} = 40$$

Here is an example. Suppose that a product bonus is payable each month up to a quarterly limit of 110.

Earnings Element or Accumulator	Month 1	Month 2	Month 3
PRDBON	40	40	(40) 30
AC QTDA	40	80	(120) 110

When processing PRDBON in month 3, the formula makes the following calculation:

$$\text{PRDBON\_FQTDA} + \text{CURR AMT VAL} > \text{LIM VR QTD LIMIT}$$

$$80 + 40 > 110$$

It then calculates the amount by which the current amount would exceed the limit:

$$\text{PRDBON\_FQTDA} + \text{CURR AMT VAL} - \text{LIM VR QTD LIMIT} = \text{LIM VR OVER LIMIT}$$

$$80 + 40 - 110 = 10$$

It then subtracts the excess amount from the current amount and pays that amount.

$$\text{CURR AMT VALUE} - \text{LIM VR OVER LIMIT} = \text{PRDBON}$$

$$40 - 10 = 30$$

PRDBON has a generation control, ERN GC PRDBON, the formula of which, LIM FM CHK PRDBON, determines if the quarter-to-date amount accumulator is equal to or greater than the limit. If it is, the system does not process the earnings. The quarter-to-date amount can be greater than the limit, despite the controls, because positive input does not use the generation control.

## Calculating Earnings Based on Other Earnings

The STRESS earning element demonstrates how an earning can be based on the value of another earning. For example, suppose that you pay 1.00 AUD stress loading for every hour of regular pay. The earnings calculation rule is Unit × Rate × Percentage, where:

Unit = Formula ERN FM REG UNIT, which returns either the employee's regular hours or regular pay standard hours.

Rate = Payee level.

Percentage = 100.

Because the value of the STRESS earning element depends on the value of either of the regular hours, it must be resolved after the regular pay has been resolved.

## Calculating Amount Earnings

There are 20 earnings elements that use a variety of methods to determine the calculation rule Amount.

### Using Flat Amounts

Six earning elements use a flat amount: FAD (first aid allowance) PHONE, CAR, PPL (paid parental leave), PRDBON (product bonus), and TRANS ADV (advance payment example).

#### Note

For paid parental leave, enter the PPL amount on the One Time (Positive Input) page, and enter the leave start and end dates on the Supporting Elements page as overrides to the delivered variables *PPL VR START DT* and *PPL VR END DT*.

### Using Formula-Based Amounts

Most of the earning elements used during termination payouts use formulas in their calculation rules. They are documented in separate topics.

#### Related Topics

- [The Termination Section](#)  
The Termination section contains a conditional formula, TER FM TERM CHECK, to check if there is either a termination date in the pay period or a termination action date in the period. The formula checks for both to accommodate a situation in which you may have not entered the termination until the pay period after the period in which the termination occurred. If the check is only on the termination date, the section is not processed, because that date is outside the current pay period begin and end dates.
- [Termination Processing](#)  
When an employee's services are terminated, regardless of the reason, the employer must make mandatory payments to the employee, depending on the circumstances. Payments can consist of:

### Using Unprocessed Payee Level Amounts

Four of the earnings have an Amount calculation rule that does not appear in a section; therefore they are not resolved. You use them as data input points, and the system uses them in lump sum D and ETP calculations. These earnings elements are REDUNDANCY, INVALIDITY, EX GRATIA, and PAY IN LIEU.

### Related Topics

- [The Termination Section](#)  
The Termination section contains a conditional formula, TER FM TERM CHECK, to check if there is either a termination date in the pay period or a termination action date in the period. The formula checks for both to accommodate a situation in which you may have not entered the termination until the pay period after the period in which the termination occurred. If the check is only on the termination date, the section is not processed, because that date is outside the current pay period begin and end dates.
- [Termination Processing](#)  
When an employee's services are terminated, regardless of the reason, the employer must make mandatory payments to the employee, depending on the circumstances. Payments can consist of:

## Using Payee-Level System-Populated Amounts

The RETRO12MTH earning element is populated by the results of the retro process, in which the formula RTO SELECT OVRDSET determines the retro override set that is used, and one of the sets forwards the earning amount to the RETRO12MTH element.

## Deducting from Regular Earnings

Sometimes, you need to reduce regular earnings by the number of hours paid by another earning element. When you pay leave using a leave earning element, those leave hours are paid instead of regular hours, so regular hours must be reduced.

You do this by using a formula to resolve the unit value of the REGPAY STDHR earnings element.

The REGPAY STDHR calculation rule is Unit × Rate, where:

Unit = ERN FM REGSTD UNIT

Rate = System element HOURLY RATE

The automatically assigned unit components of all the earnings that reduce regular hours are members of accumulator ERN AC REDUCE HRS. The delivered members are : SCK\_UNIT, LSL\_UNIT, OTHLV\_UNIT, SHFNT2\_UNIT, ANNRA\_UNIT, ANN\_UNIT, PUB\_UNIT, and LWOP\_UNIT.

The period total units from the accumulator are subtracted from the calculated regular standard hour units for the period.

Here is the process that ERN FM REGSTD UNIT uses to resolve the unit for the REGPAY STDHR earnings element (the last line reduces the regular earnings by the value of the accumulator):

1. Obtains the payee's standard hours frequency from the Job record.
2. Retrieves the annual factor for the employee's standard hours frequency; for example, annual frequency 52 for 40 standard hours per week.
3. Multiplies the employee's standard hours by the annual factor (annualization).
4. Retrieves the pay period frequency.
5. Obtains the annual factor.
6. Divides the annualized standard hours (step 3) by the annual factor (deannualization).
7. Subtracts the value of ERN AC REDUCE HRS.

The last line of the formula covers steps 6 and 7:

```
GP TEMP001 NUM / AUS VR ANNL FCTR – ERN AC REDUCE HRS >> ERN FM REGSTD
UNIT
```

## Calculating Rolling Average Earnings

You can set up an earnings element in which the rate is determined by the average rate of an earnings elements or set of earnings elements over a rolling period (such as the preceding 12 months).

The ANNRA (annual leave rolling average) earnings element is set up this way. Its calculation rule is  $\text{Unit} \times \text{Rate}$ , where:

Unit = Payee level

Rate = Formula ERN FM ROLL AVG

In a rolling average calculation based on, for example, retrieving the average rate over 12 months for a monthly pay group, the formula retrieves the value *12* from variable ERN VR ROLL UNIT—set as a pay group supporting element override—and the value *months* from AUS VR FREQ TYPE retrieved from the array AUS AR FREQUENCY.

You can calculate rolling averages for monthly, fortnightly, and weekly pay groups. The following example is based on months:

### Example

The ANNRA earnings element must be paid in December 2002 for a monthly pay group, and the rate is the average rate of a group of earnings elements over the preceding 12 months. The group of earnings consists of the members of the two life-to-date accumulators ERN AC ROLLAVG AMT and ERN AC ROLLAVG HRS. The earnings rate formula:

1. Uses historical rule ERN HR R/A END to retrieve the amount and hours balances of accumulators ERN AC ROLLAVG AMT and ERN AC ROLLAVG HRS, respectively, at the end of the preceding month (November).

Call these balances the end amount (EA) and end hours (EH).

2. Uses the historical rule ERN HR R/A START to obtain the amount and hours balances of the same accumulators 12 months earlier, at the end of December 2001 (the start date).

Call these balances the start amount (SA) and start hours (SH).

3. Calculates the amount difference (AD) and hours difference (HD) over the rolling average period, as follows:

$$EA - SA = AD$$

$$EH - SH = HD$$

4. Completes the calculation, as follows:

$$AD \div HD = \text{ANNRA rate for December 2002}$$

When calculating rolling averages for fortnightly or weekly pay groups, the formula obtains the accumulator balances at 14 or 7 days, respectively, prior to the period end date of the December 2002 ANNRA pay run (EA and EH).

It then uses the ERN VR ROLL UNIT value to calculate the start date so that it can retrieve the amount and hours balances at that date (SA and SH), and it completes the calculation.

## Setting Up the Rolling Average Earnings Calculation

To set up rolling average earnings calculations:

1. Populate the amounts and hours accumulators with the respective earnings or automatically assigned units on which the rolling average calculation is based.
2. Assign the ANNRA earnings element to an employee as positive input, and enter the unit's value.  
The unit's value is the number of ANNRA hours that you want paid at its calculated rate.
3. By supporting element override at the pay group level, set the variable ERN VR ROLL UNIT to the number of months, fortnights, or weeks that the system must evaluate to retrieve period amount and hours data for use in the calculation.

## Creating Earnings Advance and Recovery

Some earnings are loans or advances; therefore, when they are paid, the system must automatically create a deduction that is processed over subsequent pay runs, recovering the loan or advance.

The PeopleSoft system provides the following elements, accumulators, formula, and generation control to demonstrate this:

Name	Type	Usage
TRANS ADV	Earnings element.	Adds advance amount to paycheck when advance occurs.
TRANS ADV AMT	Accumulator.	Stores amount of advance.
TRANS BAL AMT	Accumulator.	Stores reducing balance.
TRANS REC	Deduction element.	Deducts portion of advance from paycheck in subsequent pay runs.
ADV FM GC CHECK	Advance recovery check formula.	Adjusts the deduction if taking it all would cause the goal amount to be exceeded.
ADV GC REC IND	Advance recovery generation control.	Controls execution of advance recovery check formula.

### Related Topics

- [Checking Goal Amounts](#)  
The calculation rule for the LOANDED deduction element is Base x Percent, where:

## Selecting Hours for Holiday Earnings

The system detects when a designated holiday occurs in a pay period. Designate days as holidays on the Holiday Schedule page, which you access by selecting **Set Up HCM**, and then **Common Definitions**, and then **Holiday Schedule**. When a holiday occurs in a pay period, the system populates the HOLIDAY HRS system element with the hours entered for that holiday on the holiday schedule.

Because a payee might not have been scheduled to work the holiday schedule hours, you can direct the system to pay different hours from those on the holiday schedule.

During normal payroll processing, when the system resolves the PUB (public holidays) earnings element, it determines the number of hours to pay each employee.

The PUB calculation rule is  $\text{Unit} \times \text{Rate}$ , where:

Unit = Formula ERN FM PUB UNIT

Rate = System element HOURLY RATE

The ERN FM PUB UNIT formula uses proration element ERN PO PUB HRS for which the numerator is ERN CT PUB HOURS and the denominator is 1.

The count formula for ERN CT PUB HOURS is ERN FM HOLIDAY HOURS. This formula checks each day in the period for a HOLIDAY HOURS value and if it finds one, determines whether the variable ERN VR SCHED TYPE is set to HOL, WRK, or ALT.

For HOL, the formula returns the holiday hours from the holiday schedule.

For WRK, the formula returns half the employee's scheduled hours if the holiday type on the holiday schedule is *Half*, or all of the employee's scheduled hours if the holiday type is *Standard*.

The result is the same for ALT, except the formula returns the hours for the payee's alternate work schedule. If there is no alternate schedule, it returns either half or all scheduled hours.

#### Note

You can designate any defined schedule as the alternate schedule on the pay group table. And at the employee level, you can assign a schedule as an alternate and it can be the pay group alternate schedule or any other of your defined schedules. Select **Global Payroll & Absence Mgmt**, and then **Payee Data**, and then **Create Overrides**, and then **Assign Work Schedule**.

Whatever the value of the variable ERN VR SCHED TYPE, the count formula returns the hours to be passed by the count to the numerator of the proration rule and the proration rule passes the count value to the formula ERN FM PUB UNIT, which is the unit for the PUB calculation rule  $\text{Unit} \times \text{Rate}$ .

#### Note

Because the count numerator (the number or hours to pay) is divided by denominator 1, no proration occurs. The count result is passed to the PUB earnings element's unit formula through the proration element because counts cannot be used directly in formulas.

## Scheduling Earnings by Using Generation Control

There may be times when you need to control the periods in which earnings are paid. In that case, you need to control when the system pays the earnings element regardless of the pay frequency (weekly, fortnightly, semimonthly, four-weekly, or monthly). For instance, you might

need to pay earnings only in the first weekly pay run of the month or only in the second fortnightly pay run of the month.

**Note**

Although these generation controls are discussed here in the context of defining earnings, you can use them to control deductions in the same way.

## Scheduling for Any Period

You control the payment of an earnings element—whatever the pay frequency—by assigning one of seven generation controls to the earnings. Five generation controls exist for periods 1 to 5 (there is a maximum of five weekly periods per month), and two additional generation controls cover two periods each (periods 1 and 3 and periods 2 and 4).

The two-period controls have the system process the earnings in both covered periods. For example, the control for periods 1 and 3 affects weekly pay runs in weeks 1 and 3 but not weeks 2, 4, and 5.

A corresponding formula exists for each generation control. When the formula returns *True*, the earning is paid.

For example, to pay an allowance for the first period of the month (period 1), the formula returns *True* for the first period of the month and *False* for the remaining periods, and the earnings element is processed.

The formula attached to each generation control has the same name except the FM element type code replaces the GC type code; for example, the generation control AUS GC PERIOD 1 has the associated formula AUS FM PERIOD 1.

**Note**

For each of the two-period generation controls, the formula calls two other formulas, one for each period. For example, the formula AUS FM PRD 1+PRD 3 calls formulas AUS FM PERIOD 1 and AUS FM PERIOD 3. Only one of the two formulas needs to return *True* for the system to pay the earning.

Weekly, fortnightly, semimonthly, and four-weekly brackets return values depending on where the pay period end date occurs.

This diagram shows the bracket values associated with each day of the month.

**Weekly Bracket - AUS BR WEEKLY**

Days	1-7	8-14	15-21	22-28	29-31
Bracket Value	1	2	3	4	5

**Fortnightly Bracket - AUS BR FORTNIGHTLY**

Days	1 - 14	15-28	29-31
Bracket Value	1	2	3

**Semi-Monthly Bracket - AUS BR SEMIMONTH**

Days	1 - 15	16 - 31
Bracket Value	1	2

**Four-Weekly Bracket - AUS BR FOURWEEKLY**

Days	1 - 28	29-31
Bracket Value	1	2

To provide examples, the following table shows the bracket value that each bracket returns for day 5 and day 27 of the month:

Bracket	Value for Day 5	Value for Day 27
Weekly	1	4
Fortnightly	1	2
Semimonthly	1	2
Four-weekly	1	1

The formula uses the bracket values, which indicate to the system whether the pay period end date is in the relevant period. The formula checks the bracket that corresponds to the frequency type.

For the period 1 formula for example:

```

If AUS VR FREQ TYPE = 'W' (weekly) Then
    If AUS BR WEEKLY = 1 Then...TRUE
If AUS VR FREQ TYPE = 'B' (biweekly or fortnightly)Then
    If AUS BR FORTNIGHTLY = 1 Then...TRUE
    
```

The formula returns *True* when the pay period end date is in the bracket value that corresponds to the period. That is, for period 2 when the bracket for a frequency type returns 2, the formula returns *True*.

For example, to have the earning paid in the first period, you attach the period 1 generation control to the earnings element. If generation control formula for period 1 returns the bracket value 1, the formula returns *True*—regardless of the frequency specified in variable AUS VR FREQ TYPE, .

If you want the earning paid in the second and fourth periods, attach the AUS GC PRD 2 +PRD4 AUS FM PRD 2 +PRD4

The following table lists the frequencies for which each formula uses the bracket value (*W* is weekly, *B* is fortnightly, *S* is semimonthly, *F* is four-weekly, and *M* is monthly):

Formula	Frequency	Comment
AUS FM PERIOD 1	W, B, S, F, M	N/A
AUS FM PERIOD 2	W, B, S, F	M is always true
AUS FM PERIOD 3	W, B	S, F, and M are always true
AUS FM PERIOD 4	W	B, S, F, and M are always true
AUS FM PERIOD 5	W	B, S, F, and M are always true

#### Note

None of the delivered earnings elements use the AUS GC PERIOD <number> generation controls; however, you can use these controls for deductions just as you use them for earnings. Deduction INSURANCE, for example, uses the AUS GC PERIOD 1 generation control.

#### Related Topics

- [Scheduling Deductions Using Generation Control](#)  
The HEALTH FUND deduction element has a generation control, LVE GC BIGGER SEG, which uses formula LVE FM BIGGER SEG.

## Scheduling for the Last Period Only

To have an earnings element paid only in the last period in a month, use generation control AUS GC LAST PERIOD to determine if the period being processed is the last period of the month; for example, period 4 or 5 for weekly pay frequency or period 2 for semimonthly. The PHONE earnings element uses this generation control.

The formula attached to this generation control is AUS FM LAST PERIOD. That formula also uses the period formulas—AUS FM PERIOD <number>—that are associated with the seven generation controls.

# 10

## Defining Deductions

### Understanding Deductions

The PeopleSoft system provides a number of deductions to demonstrate the flexibility of Global Payroll rules and meet common processing requirements, such as the preservation of minimum net pay. The following sections discuss various ways to use deductions and supporting elements.

### Delivered Deduction Elements

In the following table, the first column combines the deduction's name and description. The code (*gc*) indicates that the deduction has a generation control. The code (*po*) indicates a post-processing formula, and the code (*pr*) indicates a pre-processing formula. The other columns indicate the deduction's calculation rule of Unit  $\times$  Rate, Unit  $\times$  Rate  $\times$  Percent, or Base  $\times$  %. The formulas used for some of the deduction codes are discussed in further detail. The code (*sy*) stands for *system element*; it is not part of the element name.

Name and Description	Unit	Rate	Base	%	Amount
<i>Section DED - PRE TAX</i>					
EE SSSPR Employee Sal. Sacrifice Super (po)			AUS GROSS	Payee Level	
<i>Section DED - PST TAX</i>					
INSURANCE Insurance (gc) (po)			AUS GROSS	5.00	
PARK Parking Fee (gc)	Payee Level	10.00			
LOANDED Loan Repayment (gc) (po)			AUS GROSS	10.00	
UNION Union Fees (gc) (po)					9.50 / period

Name and Description	Unit	Rate	Base	%	Amount
TRANS REC Advance Recovery Example (gc) (po)			TRANS ADV AMT	Payee Level	
SALDED Advance Repayment					2500.00 / period
SOCIAL Social Club (gc)					8.00 / month
LOAN REPAY Loan Repayment (Term) (gc)					TER FM LOAN REPAY
HEALTH FUND Health Fund (gc)					Payee Level
<i>Section DED - TAX</i>					
MARGINAL TAX Marginal Tax (po)					TAX FM MARGINAL
ANNLSD TAX Annualized Tax					TAX FM ANNLSD
PERIODIC TAX Periodic Tax					TAX FM PERIODIC
HELP HELP Amount (po)					TAX FM HELP
SFSS SFSS Amount (po)					TAX FM SFSS
LUMP A TAX Lump Sum A Tax					TAX FM LUMP A
LUMP B TAX Lump Sum B Tax					TAX FM LUMP B
LUMP C TAX Lump Sum C Tax					TAX FM LUMP C
LUMP E TAX Lump Sum E Tax					TAX FM LUMP E

Name and Description	Unit	Rate	Base	%	Amount
<i>Section DED - NONTAX</i>					
SGCMAN SGC Mandatory (gc) (po)			SUP FM CALC BASE	AUS VR SGCMAN PCT	
AWARDMAN Award Super Mandatory (gc) (po)					SUP FM TIERBSD AMT
ER ADDLSPR Employer Add'l Super (po)			SUP FM CALC BASE	SUP VR ERADDL PCT	
ER MATCHSPR Employer Matching Super (po)			AUS GROSS	SUP BR CMPNY PCT	
EE SUPER Employee Super					Payee Level
CHARITY Deductible Gift Recipient					Payee Level

There are also 22 deductions that relate to salary packaging; and they all start with the letters *SP*.

### Related Topics

- [PeopleSoft Human Resources Administer Salary Packaging: Understanding Salary Packaging Setup](#)
- [PeopleSoft Human Resources Administer Salary Packaging: Setting Up Salary Packaging Human Resources and Global Payroll Tables](#)
- [PeopleSoft Human Resources Administer Salary Packaging: Modelling Salary Packages for Employees](#)
- [PeopleSoft Human Resources Administer Salary Packaging: Modelling Salary Packages for Applicants](#)
- [PeopleSoft Human Resources Administer Salary Packaging: Copying Applicant Salary Packages to the Employee Salary Package Component](#)
- [PeopleSoft Human Resources Administer Salary Packaging: Understanding Salary Package Modelling](#)
- [PeopleSoft Human Resources Administer Salary Packaging: Understanding Managing Salary Packages](#)
- [PeopleSoft Human Resources Administer Salary Packaging: Enrolling in Salary Packages](#)
- [PeopleSoft Human Resources Administer Salary Packaging: Reviewing Salary Packages](#)

- PeopleSoft Human Resources Administer Salary Packaging: De-Enrolling from Salary Packages
- PeopleSoft Human Resources Administer Salary Packaging: Making Effective-Dated Changes to Confirmed Salary Packages
- PeopleSoft Human Resources Administer Salary Packaging: Running Salary Packaging Reports

## Calculating Tax Deductions

The tax deductions are in the section DED - TAX. All eight tax deductions have a calculation rule of Amount, and the amount is a formula specific to each deduction; for example, TAX FM MARGINAL or TAX FM LUMPA.

### Related Topics

- [Understanding the Setup for Taxation Calculations](#)  
The calculation of tax, using the tax scales, is only a part of managing taxation. You also need to enter details about the pay entity (usually the company or organization), provide the Australian Tax Office (ATO) with tax file number (TFN) information, enter and maintain tax-related information about each employee, and submit statutory reports to the ATO.
- [Understanding Taxation Processing](#)  
The Australian country extension to Global Payroll comes with all the elements required to calculate a payee's tax correctly. The system calculates taxes in a variety of situations, such as multiple payments within a calendar period, annualized tax, mid-period hires, retroactive taxation, and terminations.

## Pre-Tax Deductions

There is only one deduction in the DED - PRE TAX section. It is EE SSSUPER (employee salary sacrifice super).

## Post-Tax Deductions

These are in section DED - PST TAX and represent typical after-tax deductions such as parking fees, union dues, and social club membership fees. The section includes repayment deductions that are generated by the system when their associated earnings are paid.

## Non-Tax Deductions

The non-tax deductions, which appear in section DED – NONTAX, are for superannuation. Three of the five deductions use a Base × Percent calculation rule. The other two deductions use amounts (one is a formula-driven amount and the other is a payee-level flat amount).

### Related Topics

- [Understanding Monitoring Salary Package Expenditure](#)  
The Administer Salary Packaging business process in Human Resources enables you to monitor and project employee expenses during a salary package period. It also provides tools to ensure that actual spending, for both employees and the organization, stays within the limits of budgeted salary packages. You can view package expenditures online as they take place, or generate reports that detail employee expenditures from their package budgets.

## Scheduling Deductions Using Generation Control

The HEALTH FUND deduction element has a generation control, LVE GC BIGGER SEG, which uses formula LVE FM BIGGER SEG.

One leave-in-advance payment option enables you to advance only the leave pay within a pay period and pay the regular pay in its normal period. When this occurs, the system determines which is the longer period—leave or regular—and applies the deduction to the longer period. The formula returns *True* if the leave period is longer, and the generation control takes the deduction from the leave pay that is advanced.

The same formula ensures that the deduction is taken when there is period segmentation due to hire or termination.

When segmentation is due to something other than hire or termination, the deduction is taken in *either*:

- The longer of two segments.
- The segment in which the period midpoint occurs, when there are more than two segments.

The UNION, LOANDED, and TRANS REC deduction elements also have generation controls. Their formulas check that the deduction has not reached a period limit or goal amount. In the case of TRANS REC, the formula verifies that the payee is still active.

The LOAN REPAY deduction element's generation control formula also checks that the payee is still active. If the payee is not active, the deduction element applies and the Amount formula, TER FM LOAN REPAY, retrieves the loan balance. The TRANS ADV and LOAN REPAY deduction elements interact through their generation control formulas. If the payee is terminated, TRANS ADV isn't resolved but LOAN REPAY is.

The INSURANCE deduction element demonstrates the use of a generation control to ensure that the deduction is taken only in the first pay period, irrespective of the pay frequency. The deduction's calculation rule is  $\text{Base} \times \text{Percent}$ , where:

Base = Accumulator AUS GROSS

Percent = 5.00

The AUS GC PERIOD1 generation control is one of seven generation controls that are discussed in the topics on defining earnings.

### Related Topics

- [Scheduling Earnings by Using Generation Control](#)  
There may be times when you need to control the periods in which earnings are paid. In that case, you need to control when the system pays the earnings element regardless of the pay frequency (weekly, fortnightly, semimonthly, four-weekly, or monthly). For instance, you might need to pay earnings only in the first weekly pay run of the month or only in the second fortnightly pay run of the month.

## Checking Goal Amounts

The calculation rule for the LOANDED deduction element is  $\text{Base} \times \text{Percent}$ , where:

BASE AUS GROSS

Percentage = 10

This deduction has a goal limit that is the maximum amount that can ever be deducted. It is not a maximum per frequency.

The DED GC LOANDED generation control first checks if any part of the deduction can be taken. Its formula, LIM FM CHK LOANDED, checks that accumulator LOANDED AC LTDA (life-to-date LOANDED), is not greater than or equal to the variable LIM VR GOAL LIMIT, which set as the supporting element override when assigning the deduction to the payee. If it is, the formula returns false and the deduction is not processed.

However, even if the deduction is processed, the system must verify that this new instance of the deduction won't exceed the goal amount if it is taken in full.

The post-process formula LIM FM LOANDED verifies this. If there is a goal limit, the system proceeds with the formula, as follows:

LOANDED AC LTDA + LOANDED\_ARR (any LOANDED arrears) + CURR AMT VALUE  
(system element, the value of LOANDED)

For example:

$1150 + 0 + 90 = 1240$  (GP TEMP001 NUM)

The formula then compares the new figure with the goal amount; for example, 1200.

If it finds that the new figure exceeds the goal amount, it subtracts the goal amount from the new figure to determine the excess amount; for example:

$1240 - 1200 = 40$  (LIM VR OVER LIMIT)

The formula then subtracts the excess amount from the current value of the deduction (for example, 90), and that becomes the value of the deduction for this pay period (which is the last time it's taken unless the goal amount is increased):

$90 - 40 = 50$

The UNION deduction element is managed in a similar way. Its generation control formula LIM FM CHK UNION checks whether Union's fiscal year-to-date accumulator is greater than or equal to LIM VR YTD LIMIT (goal amount for the year). If it is greater, the deduction is not processed.

If the deduction is processed, the post-process formula determines the effect that the new deduction would have on the year's goal amount if paid in full, and it reduces the deduction if necessary.

The LOANDED deduction element is assigned at payee level as an earning and deduction assignment. Set the goal amount as the numeric value of the element override, LIM VR GOAL LIMIT. Because goal amounts are typically different for each employee, the variable is not set as a system element override at the deduction level.

## Managing Garnishments

Garnishments are deductions. You set up garnishment deductions just as you set up any other deduction.

This topic discusses ways to manage garnishments.

## Pages Used to Manage Garnishments

Page Name	Definition Name	Usage
<a href="#">Assign Garnishments AUS Page</a>	GPAU_GARN_DTLS	Enter details about a particular garnishment for a payee.
Specify Protected Net Pay AUS Page	GPAU_PROTECT_NET	<p>Enter the protected net pay amount for a payee.</p> <p>The system cannot take the whole COURT ORDER deduction if taking it would make the employee's net pay less than the protected amount. It can deduct to that protected amount, but no more.</p> <p>Protected net pay is only protected in relation to the COURT ORDER deduction. After the system has processed COURT ORDER, the accumulator AUS NET is the minimum net pay amount. That minimum net pay is not protected against any other deductions that might apply.</p>

## Calculating Garnishment Deductions

The PeopleSoft system provides three garnishment deduction elements: CHILDSUPPORT, WRIT, and COURT ORDER. Each is resolved differently.

### Child Support

The CHILDSUPPORT deduction element has calculation rule Amount, and the amount is set at 50 AUD.

### Writ

The WRIT deduction element has the calculation rule  $\text{Base} \times \text{Percent}$ , where:

Base = Accumulator AUS AC DISP EARNNS (disposable earnings)

Percent = 5.0

Accumulator AUS AC DISP EARNNS members are:

- Accumulator AUS GROSS (+)
- Accumulator AUS TAX (-)

### Court Order

The COURT ORDER deduction element has a generation control, GRN GC COURTORDER, which uses formula GRN FM PROC STATUS to verify that the processing status of the garnishment (set on the Garnishment Details page) is *Approved*.

The calculation rule for COURT ORDER is Amount, where the amount is formula GRN FM ALL BUT NET. The formula deducts all but the protected net pay amount from disposable earnings. Disposable earnings are stored in accumulator AUS AC DISP EARNS:

Segment accumulator AUS GROSS – Segment accumulator AUS TAX = AUS AC DISP EARNS (disposable earnings)

AUS AC DISP EARNS (disposable earnings) – DED VR PROTECT NET (protected net pay) = COURT ORDER deduction

The protected net pay variable is the amount that you enter in the single field on the Protected Net Pay page. The amount that you enter becomes the variable through the array AUS AR PROTECT NET in the INITIALISATION section in the AUS PAYROLL process list.

## Assign Garnishments AUS Page

Use the Assign Garnishments AUS page (GPAU\_GARN\_DTLS) to enter details about a particular garnishment for a payee.

Navigation:

**Global Payroll & Absence Mgmt**, and then **Payee Data**, and then **Garnishments/Court Orders**, and then **Assign Garnishments AUS**, and then **Assign Garnishments AUS**

This example illustrates the fields and controls on the Assign Garnishments AUS page. You can find definitions for the fields and controls later on this page.

The garnishment deduction elements calculate the amount to deduct, but you may need to record other garnishment details. The Garnishments page is for recording information only. There is no system processing associated with the data, except that the generation control for COURT ORDER checks the status.

Field or Control	Description
<b>Element Name</b>	Enter the garnishment deduction.
<b>Garnishment Type</b>	Select the type. Options are <i>Assignment</i> , <i>Bankruptcy</i> , <i>Child Supt</i> (child support), <i>Tax Levy</i> , <i>Dependant</i> , and <i>Writ</i> .

---

<b>Field or Control</b>	<b>Description</b>
<b>Response Required Date/Time</b>	Enter the date and time that a response is required, as indicated on the garnishment order.
<b>Order Reference Number</b>	Displays the reference number, which is supplied with the order for the garnishment.
<b>Received Data and Time</b>	Record the date and time that you received the garnishment order.
<b>Processing Status</b>	Select from <i>Approved</i> , <i>Completed</i> , <i>Received</i> , <i>Rejected</i> , and <i>Suspended</i> . The garnishment deduction COURT ORDER is taken only if the status is <i>Approved</i> .
<b>Contact Name and Phone</b>	Enter the recipient's contact name and phone number.
<b>Admin Fees</b> (administrative fees)	Enter the amount of any fees that you can charge for administering the garnishment.
<b>Comment</b>	Enter any comments about the garnishment specification.

---

# 11

## Managing Taxation Processing

### Understanding Taxation Processing

The Australian country extension to Global Payroll comes with all the elements required to calculate a payee's tax correctly. The system calculates taxes in a variety of situations, such as multiple payments within a calendar period, annualized tax, mid-period hires, retroactive taxation, and terminations.

As well as entering details about the pay entity (usually a company or organization), you must provide the Australian Tax Office (ATO) with TFN information. You need to enter and maintain tax-related information about each employee and submit statutory reports to the ATO.

#### Related Topics

- [Understanding the Setup for Taxation Calculations](#)  
The calculation of tax, using the tax scales, is only a part of managing taxation. You also need to enter details about the pay entity (usually the company or organization), provide the Australian Tax Office (ATO) with tax file number (TFN) information, enter and maintain tax-related information about each employee, and submit statutory reports to the ATO.
- [Viewing Tax Scales](#)  
The PeopleSoft system provides several pages that display tax scales and rates.

### Understanding Retroactive Tax Processing

Global Payroll for Australia provides payroll rules and elements to calculate taxes on additional payments that are granted retroactively. An additional payment can include a:

- back payment (including lump sum payments in arrears)
- commission
- bonus or similar payment.

In this section we discuss the retroactive tax calculation methods, the key PeopleSoft delivered elements used to calculate retroactive taxes, and the inputs that users must make to ensure correct retroactive tax processing.

### Calculating Taxes to Withhold for Retroactive Additional Payments

There are two methods to work out the amount to withhold from an additional payment:

- Method A – uses simple calculations, more suited to employers who have to calculate withholding amounts manually.
- Method B (i and ii) – uses complex calculations and is best suited to employers who use computer based payroll systems.

The PeopleSoft system uses Method B, as it calculates the withholding amounts with better accuracy when compared to Method A.

### Method B (i) – Calculating Taxes to Withhold for Additional Payments That Apply to Specific Periods in the Current Financial Year

To calculate the Marginal, HELP, and SFSS tax amounts to withhold from an additional payment accrued in the same financial year, Global Payroll for Australia uses the following formulas:

Tax	Formula
Marginal Tax	TAX FM MARGINAL calculates Marginal Tax. The formula has a Post Process Formula TAX FM PST MRG TAX to store the tax on RETRO CY, which in turn is accumulated for tax on back payment calculation.
HELP	The post process formula TAX FM PST HELP calculates HELP on retro from the current year.
SFSS	The post process formula TAX FM PST SFSS calculates HELP on retro from the current year.

The system determines how much of the payment accrued in each prior pay period. After calculating the correct amount, it adds this amount to the other payments made in each of the prior pay periods to calculate the withholding tax, as described here:

1. Calculate the additional payment applied to each earlier pay period in the current financial year.
2. For the first affected pay period, add the additional payment relevant to that period to the normal earnings previously paid to get total earnings for that period.
3. Use the relevant tax table to find the amount to be withheld from the total earnings for that period.
4. Subtract the amount previously withheld for the period from the amount at step 3.
5. Repeat steps 2–4 for each pay period affected. Add the amounts calculated in step 4 for each pay period for the withholding on the additional payment.
6. Use the same tax table to find the amount to be withheld from the payee's gross earnings (excluding additional payments) for the current pay period.
7. Calculate the total PAYG withholding for the current pay period by adding the withholding on the additional payment (step 5) to the withholding on the gross earnings (step 6).

#### **Note**

In Method B (i), additional payments primarily refer to back payments that were supposed to have been paid in a prior period. Hence a bonus can be part of such additional payments only if such bonus was intended to be paid in a prior period.

### Method B (ii) – Calculating Taxes to Withhold for Additional Payments That Apply to Previous Financial Years

To calculate the periodic tax, HELP and SFSS taxes to withhold for additional payments that apply to previous financial years, Global Payroll for Australia uses the formulas:

Tax	Formula
Periodic Tax	Formula TAX FM PERIODIC calculates tax on the total of the followings: RETRO PY (back payments related to previous year), RETRO12MTH (back payments from prior fiscal years and before 12 months from the payment date).
HELP	Formula TAX FM HELP is used to calculate the amount on normal earnings, plus back payments relating to the current financial year. TAX FM PST HELP is used to calculate HELP on back payments.
SFSS	Formula TAX FM SFSS is used to calculate the amount on normal earnings, plus back payments relating to the current financial year. TAX FM PST SFSS is used to calculate SFSS on back payments.

Using this method, the system calculates withholding by averaging all additional payments made in the current financial year over the number of pay periods in a year, and applying that to the average total earnings to date.

1. Calculate the average total earnings paid to the payee over the current financial year to date. Ignore any cents.
2. Use the relevant tax table to find the amount to be withheld from the average total earnings in step 1.
3. Add all additional payments made in current financial year where Method B (ii) was used to calculate the withholding, to the additional payment in current pay. Then divide by the number of pay periods in the year (that is, 52 weekly pay periods, 26 fortnightly pay periods or 12 monthly pay periods). Ignore any cents.
4. Add the amount at step 3 to the average total earnings at step 1.
5. Use the relevant tax table to find the amount to be withheld from the amount at step 4.
6. Subtract the amount at step 2 from the amount at step 5.
7. Multiply the amount in step 6 by the number of pay periods used in step 3.
8. Subtract any amounts previously withheld from additional payments in the current financial year where Method B (ii) was used, from the amount at step 7.
9. Multiply the additional payment being made in the current pay period by 47%.

#### Note

There is a withholding limit of 47% on additional earnings when the total withholding is applied to additional earnings. (The withholding limit is set by the Australian Tax Office and is subject to change. The rate at the time this document was prepared was 47%.) When calculating withholding such a limit can be applied to any of the withholding elements. By default, the system executes the withholding elements in the following sequence: HELP, SFSS, PERIODIC TAX (PAYG).

10. Use the lesser amount of Step 8 and Step 9 for the withholding on the additional payment. Ignore any cents.
11. Use the relevant tax table to find the amount to be withheld from the payee's gross earnings (excluding additional payments) for the current pay period.
12. Calculate the total PAYG withholding for this pay period by adding the withholding on the additional payment (step 10) to the withholding on the gross earnings (step 11).

**Note**

The system uses Method B (ii) for back payments that relate to a prior financial year, and bonuses, commissions or other additional payments that do not relate to a single pay period.

The PeopleSoft system uses the Method B (i and ii) to manage the following tax situations:

- Method B (i) - Taxes owed on multiple additional payments in the current pay period. This includes marginal tax, HELP, and SFSS.
- Method B (ii) - Taxes owed on multiple additional payments in the previous financial years. This includes periodic tax, HELP, and SFSS.

### Key Elements Used for Retroactive Tax Processing of Salaries and Wages Additional Payments Following Method B (i) and Method B (ii)

Element	Element Type	Use
MARGINAL TAX	Deduction	This element calculates the marginal tax.
HELP	Deduction	This element calculates the HELP tax.
SFSS	Deduction	This element calculates the SFSS tax.
TAX FM MARGINAL	Formula	This element is used by the deduction MARGINAL TAX to calculate the marginal tax.
TAX FM HELP	Formula	This element is used by the deduction HELP to calculate the HELP tax.
TAX FM SFSS	Formula	This element is used by the deduction SFSS to calculate the SFSS tax.
PERIODIC TAX	Deduction	This element calculates the periodic tax.
TAX FM PERIODIC	Formula	This element is used by the deduction PERIODIC TAX to calculate the periodic tax. This element calculates tax on the total of the followings: RETRO PY (back payments related to previous year), RETRO12MTH (back payments from prior fiscal years and before 12 months from the payment date).
TAX FM PST HELP	Formula	This element is used by the deduction HELP to calculate the HELP tax on back payments.
TAX FM PST SFSS	Formula	This element is used by the deduction SFSS to calculate the SFSS tax on back payments.

Element	Element Type	Use
TAX FM PST FRGN	Formula	<p>This element stores tax on retro from the current year in the element TAX VR FRGN DELTA, which in turn is accumulated as FRGN DELTA_FYTDA (This works in a similar manner as the MARGINAL TAX's post process formula TAX FM PST MRG TAX).</p> <p>TAX FM PST FRGN also calls TAX FM BACK PAY by feeding RETRO FR CY (retro from the current fiscal year) and RETRO FR PY (retro from prior fiscal years and within 12 months from the payment date) as inputs and resolves tax into PG TX FRGINC element.</p>
TAX DT CURR -12MT	Date	<p>This element retrieves the current period payment date from the system element CURR PRD PYMT DT and subtracts one year from it to determine the date that is exactly 12 months prior to it.</p> <p><b>Note:</b> The date 12 months before the payment date is critical to the tax process because the calculation method varies depending on whether salary or wages accrued more than or less than 12 months prior to the payment date.</p>

---

Element	Element Type	Use
TAX DR PERIOD RTO	Duration	<p>TAX DR PERIOD RTO returns the difference between the retro start date or date that payments began accruing in the past (contained in the variable TAX VR RTO STRT DT) and the tax year begin date (contained in the date element TAX DT TAXYR BGN). The difference between these dates is equivalent to the duration that payments accrued over the previous year. This duration is expressed in days and is used by the formula TAX FM PERIOD WK (see below).</p> <p><b>Note:</b> The value of the element TAX VR RTO STRT DT is set by the formula TAX FM RTO STRT DT to ensure that back payments and wages are divided by the correct number of pay periods in step 2 of the calculations described above.</p>

Element	Element Type	Use
TAX BR PRD FACTOR	Bracket	<p>This bracket returns the period factors that enable the formula TAX FM PERIOD WK (see below) to convert the number of days returned by the duration element TAX DR PERIOD RTO to a specific number of weeks, biweekly periods, months, or other durations depending on the normal pay period length. The search key in the bracket is the system element PRD FREQ NAME (period frequency name), and the specific frequencies for which the bracket returns period factors are W (weekly), B (biweekly), F (every four weeks), and M (monthly).</p> <p><b>Important:</b> You may need to define pay period factors in addition to those delivered by PeopleSoft. To do this, enter the number of weeks in the pay period for each pay period frequency you add to the bracket. For example, for a pay period frequency of every three weeks, the period factor would be 3, since there are three weeks in the period.</p> <p><b>Note:</b> Define pay period frequencies using the Frequency Table component in PeopleSoft Human Resources (FREQUENCY_TBL).</p>
TAX FM PERIOD WK	Formula	<p>This formula divides the duration in days returned by the element TAX DR PERIOD RTO by seven to arrive at a duration in weeks. Global Payroll for Australia later converts this weekly duration to the correct number of months, biweekly periods, or four-weekly periods (depending on the applicable pay period length) using the conversion factor supplied by the bracket TAX BR PRD FACTOR (see above).</p>

Element	Element Type	Use
TAX FM RTO STRT DT	Formula	This formula sets the value of the variable TAX VR RTO STRT DT used by the duration element TAX DR PERIOD RTO (see above). If the date the payments begin accruing is greater than 12 months prior to the payment date, this formula sets the value of TAX VR RTO STRT DT (retro start date) equal to the date returned by the element TAX DT CURR -12MT (the date that is exactly 12 months before the payment date). This is to ensure that the back payments are divided by the standard number of pay periods in a year (according to step 2 under Tax Calculations When Salary or Wages Accrued More Than 12 Months Before the Payment Date). And if the date payments begin accruing is less than or equal to 12 months prior to the payment date, the formula sets the value of TAX VR RTO STRT DT (retro start date) equal to the effective date of the retro trigger contained in the element TAX VR TRGR EFFDT. This is to ensure that the payments are divided by the number of pay periods to which they apply (as described in step 2 under Tax Calculations When Salary or Wages Accrued Less Than 12 Months Before the Payment Date).

## Understanding Periodic Tax for Leave Payments on Termination

To calculate periodic tax for leave payments on termination, Global Payroll for Australia averages the earnings over 12 months and then brings the average down to a per period amount by dividing it by the employee's pay period factor (that is, the number of pay periods in a year for the employee). The correct pay period factor for each employee is returned by the formula TAX FM TAX PERIODS (the pay period factor is 12 for employees paid monthly, 52 for employees paid weekly, and so on), and the tax is calculated by the deduction PERIODIC TAX which uses the formula TAX FM PERIODIC to determine the correct tax amount.

If you want to use the periodic tax formulas to calculate taxes on other earnings such as quarterly paid bonuses, you can modify TAX FM PERIODIC and TAX FM TAX PERIODS to suit your specific requirements.

**Note**

You can define your own pay period factors for periods not defined by PeopleSoft. To do this, modify the formula TAX FM TAX PERIODS so that it includes the factors corresponding to the new periods.

You can override the formula TAX FM TAX PERIODS at the Payee Level.

Global Payroll for Australia also calculates the periodic tax for HELP and SFSS using the formulas TAX FM HELP PERIOD and TAX FM SFSS PERIOD respectively to average earnings over 12 months.

**Note**

To invoke the periodic tax calculation you need to maintain the PD GRS PERIODIC accumulator. In the case of termination pay, this means maintaining the segment accumulator PD GRS LUMP MARGNL, which contributes to PD GRS PERIODIC. This accumulator contains the leave earnings that are normally paid on termination by means of positive input.

See [Understanding Taxable Earnings Accumulators](#).

## Understanding Taxable Earnings Accumulators

There are several taxable earnings accumulators to which you may need to add earning elements that you create yourself to supplement or replace the earnings delivered with Global Payroll for Australia. These are the PD MARGINAL, PD GRS ANNULISED, and PD GRS PERIODIC accumulators. They are used to calculate marginal, annualized, and periodic taxes respectively. When you create a new earning element, you should evaluate it to determine whether it is subject to one of these taxes, and if so, you should add it to appropriate tax accumulator.

## Entering Information for Tax Processing

The correct calculation and reporting of tax depends on the employee data that is stored in the system.

This topic discusses ways to enter information for tax processing.

## Pages Used to Enter Information for Tax Processing

Page Name	Definition Name	Usage
<a href="#">Maintain Tax Data AUS Page</a>	GPAU_EE_TAX_DTLS	Enter individual payees' tax data.
<a href="#">Review/Update Tax Scales AUS Page</a>	GPAU_RC_TX01_SQR	Report employees' tax scales or update the tax scales if the TFN exemption expiry date has passed.

## Maintain Tax Data AUS Page

Use the Maintain Tax Data AUS page (GPAU\_EE\_TAX\_DTLS) to enter individual payees' tax data.

Navigation:

**Global Payroll & Absence Mgmt**, and then **Payee Data**, and then **Taxes**, and then **Maintain Tax Data AUS**, and then **Maintain Tax Data AUS**

This image is the first of two examples illustrating the fields and controls on the Maintain Tax Data AUS page. You can find definitions for the fields and controls later on this page

The screenshot displays the 'Maintain Tax Data AUS' page for user David Holley (Person ID KA0004). The page is divided into two main sections: 'Tax File Number' and 'Tax Details'.

**Tax File Number Section:**

- \*Effective Date: 01/01/2000
- \*TFN Status: TFN Provided
- Tax File Number: Entered (with a 'Re-Enter TFN' button)
- TFN Disclose to Superannuation
- TFN Declaration sent to ATO

**Tax Details Section:**

- \*Pay Entity: KAAUSBI (Australian Business Institute)
- \*Balance Group Nbr: 000
- \*Tax Scale: 7 (Tax Free Threshold (No Loading))
- Basis of Payment: Full Time
- HELP or TSL Debt
- SFSS Debt

**Medicare Levy Details Section:**

- Calculate Levy Adjustment
- Spouse
- Nbr of Dependents: [ ]

This image is the second of two examples illustrating the fields and controls on the Maintain Tax Data AUS page. You can find definitions for the fields and controls later on this page

<b>Rebates</b>			
Other Rebates	<input type="text"/>	Total Rebate	<input type="text"/>
▶ Tax Adjustments			
<b>Contractor Details</b>			
<input type="checkbox"/> Contractor	ABN	<input type="text"/>	ABN Branch <input type="text"/>
<b>Declaration</b>			
<input checked="" type="checkbox"/> Signature Present	Date Signed	<input type="text" value="01/01/2000"/>	

To calculate a payee's tax, the array TAX AR EE TX DTL retrieves each payee's tax data. If you have not entered all the data required, an error message indicates that payee tax information is required.

Field or Control	Description
<b>TFN Status</b>	<p>Select the status. Options are:</p> <p><i>Applied</i>: The payee has shown on the employment declaration that there is an application for a TFN. The system adds the current date as the TFN exempt start date and a date 28 days later as the TFN exempt end date. In the interim, the system displays <i>11111111</i> as the payee's TFN.</p> <p><b>Note</b>: The exempt start and end date fields are unavailable for all statuses except <i>Applied</i> and <i>Not Supp</i> (not supplied).</p> <p><i>F/P Pens</i> (full or part pension): If the payee is on a full or part pension, the employee is exempt from providing a TFN. The system displays <i>44444444</i> as the payee's TFN.</p> <p><i>Incrct TFN</i> (incorrect TFN): If the payee has supplied an incorrect TFN, the system does not allow you to enter a TFN.</p> <p><i>Not Supp</i> (not supplied): If the payee has not supplied a TFN, the system adds the current date as the TFN exempt start date and a date 28 days later as the TFN exempt end date. In the interim, the system displays <i>00000000</i> as the payee's TFN.</p> <p><i>TFN NotReq</i> (TFN not required): Used when a TFN is not required; for example, for contractors. The system displays <i>00000000</i> as the payee's TFN.</p> <p><i>TFN Prov</i> (TFN provided): The payee has provided a TFN. After you enter the TFN, the system hides the entry, displays <i>Entered</i> in the field, and displays a <i>Re-Enter TFN</i> button. If you enter an invalid TFN, the system warns you. To re-enter a tax file number, click the <i>Re-Enter TFN</i> button.</p> <p>If an interim notice is in force for the employee, select <i>TFN Provided</i> and enter <i>222 222 222</i>.</p> <p><i>Under 18</i>: An employee under 18 years of age is exempt from quoting a TFN. The system automatically displays <i>33333333</i> as the payee's TFN.</p>
<b>Tax File Number</b>	<p>Enter the TFN number. Validation occurs, and you receive a warning message if the number fails validation.</p>
<b>Re-Enter TFN</b>	<p>This field is available until you enter a valid TFN. Use it to enter a different TFN if the number that you enter fails validation.</p>
<b>TFN Disclose to Superannuation</b>	<p>Select this check box to indicate that the payee has authorized you to disclose the TFN to a superannuation organization. There is no processing associated with this check box. You can use it when reporting to a superannuation provider.</p>

Field or Control	Description
<b>Pay Entity</b>	Enter the pay entity to which the payee supplied the tax file declaration.
<b>Balance Group No</b> (balance group number)	Use balance group numbers to identify the accumulator in which the system stores tax balances. You can only select balance group numbers entered for the employee on the Job Data - Payroll page.
<b>Tax Scale</b>	Enter the tax scale. Options are: 1: Tax Free Threshold Not Claimed 2: Tax Free Threshold Claimed 3: Non Residents 4N: TFN Not Provided - Non-Resident 4R: TFN Not Provided - Resident 5: Full Medicare Levy Exemption 6: Half Medicare Levy Exemption 7: Tax Free Threshold (No Loading) 8: Seniors - Single 9: Seniors - Separated by Illness 10: Seniors - Member of a Couple 11: H - Working Holiday Maker 12: Single Half ML Exem 13: Illness Separated Half ML Exem 14: Member of Couple Half ML Exem 15: Single Full ML Exem 16: Illness Separated Full ML Exem 17: Member of Couple Full ML Exem <b>Note:</b> From 01st July 2024, the New Tax Scales from 12-17 are in effect. They are designed to accommodate Seniors with Full and Half Medicare Levy Exemptions.
<b>Basis of Payment</b>	Select the basis of payment. Options are <i>Casual</i> , <i>Full Time</i> , <i>Labour Hire</i> , and <i>Part Time</i> .
<b>HELP Debt</b>	Select if the payee has HELP debt.
<b>SFSS Debt</b>	Select if the payee has an SFSS debt.

### Medicare Levy Details

Field or Control	Description
<b>Calculate Levy Adjustment</b>	Deselect this check box to prevent the system from calculating Medicare levy adjustments. By default, the check box is selected. If you do deselect this check box, the system does not process any other selected options in the group box.
<b>Spouse</b>	Select if the payee has a dependent spouse only.
<b>No. of Dependents</b> (number of dependents)	Enter the number of dependents, including the spouse if the spouse is a dependent.

## Rebates

The Tax offset Amount is to inform government of the employment or engagement relationship and define the withholding rates applied by the payer. This is an annual dollar amount of total offsets claimed by employee to vary their withholding, this field should be supplied only if employee claims an offset.

Payees may be eligible to claim a tax offset to vary their PAYGW amount. The offset is claimed by providing the payer with the completed Withholding Declaration form/s (NAT 3093, 5072)

Field or Control	Description
<b>FTB Rebate</b>	If the payee is applying to have this benefit paid by reduced withholding tax, enter the amount of the reduction that the payee is requesting.
<b>Other Rebates</b>	If the payee is applying to have combined dependent-spouse, special, or zone rebates paid by reduced withholding tax, enter the amount of the reduction that the payee is requesting.
<b>Total Rebate</b>	The system displays the total of the FTB and other rebates.

## Tax Adjustment

Field or Control	Description
<b>PAYG Adjustment</b>	A check box exists for each type of tax: PAYG, Annualised, HELP and SFSS. Select the check box for each tax for which you want to make an adjustment. This makes the adjustment fields available for entry. For each tax, you can set an adjustment of override percentage or amount, or an adjustment of additional percentage or amount.

## Contractor Details

Field or Control	Description
<b>Contractor</b>	Select if the payee is a contractor.
<b>ABN</b>	If you select <i>Contractor</i> , enter the ABN. The system warns you if the number that you enter is not a valid ABN.
<b>ABN Branch</b>	If you select <i>Contractor</i> , enter the ABN branch

## Declaration

Field or Control	Description
<b>Signature Present</b>	Select if the payee has signed the tax declaration form.
<b>Date Signed</b>	Enter the date that appears on the declaration.

## Review/Update Tax Scales AUS Page

Use the Review/Update Tax Scale Update page (GPAU\_RC\_TX01\_SQR) to enter individual payees' tax data.

Navigation:

**Global Payroll & Absence Mgmt**, and then **Payee Data**, and then **Taxes**, and then **Review/Update Tax Scales AUS**

This example illustrates the fields and controls on the Review/Update Tax Scales AUS page. You can find definitions for the fields and controls later on this page.



When you hire a new payee and select a tax scale, that tax scale might need to be changed. For example, when someone applies for a TFN, they have a 28-day exemption period. If a TFN is not entered in the system before the expiry of the 28 days, the tax scale must be reset. You can run the GPAUTX01.SQR process on the Tax Scale Update page to have the system do this for you. This process checks the TFN status to determine if it is *Applied* or *Not Supp* (not supplied). If the 28 days have expired, the system performs the following actions:

- Inserts a new effective-dated row of status *Not Supp* (for both *Applied* and *Not Supp*).
- Sets the exempt start and end dates to null.
- Resets the payee's tax scale to 4N or 4R.

To create a report of only employees whose tax scale needs to be changed—for example, if you want to change them manually—you can use the process page to generate the report without making automatic updates. To create a report only, deselect the **Update Payee's Tax Scale** check box.

## Submitting the Electronic TFN Declaration

The output of the GPAU\_TFN\_ELC Application Engine process is a magnetic media file for submission to the ATO.

This topic discusses ways to submit the electronic TFN declaration.

**Note**

The information that you enter on the tax information pages is included in the following files, which you submit to the ATO: the Group Tax file, the Payment Summaries file, and the TFN Declaration file.

## Page Used to Submit the Electronic TFN Declaration

Page Name	Definition Name	Usage
TFN Declaration - Electronic Page	GPAU_RC_TFN_ELEC	Set the report start and end dates and select the pay entities for the report. You can specify a run type of <i>Production or Test</i> .

# 12

## Reporting State Payroll Tax Liabilities

### Understanding State Payroll Tax Reporting

The State Payroll Tax report provides detailed information about the earnings, benefits, deductions, and expenses that are identified as payroll taxable or payroll tax exempt. Details are also provided for termination payments that are payroll tax exempt

#### Note

The State Payroll Tax report is not a complete representation of payroll tax liabilities. Other payments and earnings that are administered outside the PeopleSoft system should be included in any returns submitted to the State Revenue Office. This may include details of companies that form part of a group but are administered outside the PeopleSoft system.

If an employee moves to a different state during a reporting period, the system uses the Job record that is valid at the time of payment of state payroll tax. For example, suppose that a weekly employee has four pay periods in the month, and the employee moves to another state during the fourth pay period. That fourth pay period is reported for the new payroll tax state.

### Running the State Payroll Tax Report

The GPAU\_SPT\_RPT Application Engine process extracts data for state payroll tax reporting, and that data is formatted as a report by the GPAUT01 Structured Query Report.

### Page Used to Run the State Payroll Tax Report

Page Name	Definition Name	Usage
<a href="#">State Payroll Tax Report Page</a>	GPAU_RC_SPT	Report the data extracted by the GPAU_SPT_RPT process.

### State Payroll Tax Report Page

Use the State Payroll Tax Report page (GPAU\_RC\_SPT) to report the data extracted by the GPAU\_SPT\_RPT process.

Navigation:

**Global Payroll & Absence Mgmt**, and then **Taxes**, and then **Payroll Tax Report AUS**, and then **State Payroll Tax Report**

---

Field or Control	Description
<b>Group Pay Entity</b>	Enter the group pay entity that you created in the Group Entity table.
<b>State Payroll Tax Base Date</b>	Select the SPT base date. Options are <i>Pay End Date</i> , <i>Payment Date</i> , and <i>Earlier of End/Payment Dates</i> . With weekly and fortnightly pay frequencies, it is not always clear in which month the earnings should be included for payroll tax purposes. Some pay periods span two months. This field determines the month to which earnings are attributable for payroll tax purposes.

---

### Related Topics

- [Identifying Data for State Payroll Tax Reporting](#)  
Before you begin configuring Global Payroll to report payroll tax, you need to identify the earnings, deductions, benefits, and expenses that are subject to payroll tax. To do this, check with the state revenue office of each state in which the organization pays employees. After you have gathered this information, run the payroll routinely and process payroll tax.
- [Setting Up Group Pay Entities](#)  
To set up group pay entities, use the Group Pay Entities AUS (GPAU\_GRP\_ENT) component.
- [Maintaining and Viewing Payroll Tax Tables](#)  
To set up payroll tax data, use the Payroll Tax Elements AUS (GPAU\_SPT\_TAX\_RATE) component.

# 13

## Administering Superannuation

### Understanding Superannuation Administration

Correct superannuation calculation and output involves the following input:

- Age-based limits
- Maximum limits
- Calculation base
- Exemption rules
- Positive input
- Employee MPF details

Superannuation output includes:

- Payslips
- Fund payments
- Online enquiries
- Interfaces and reports.

The following diagram shows the user input and system output for superannuation.

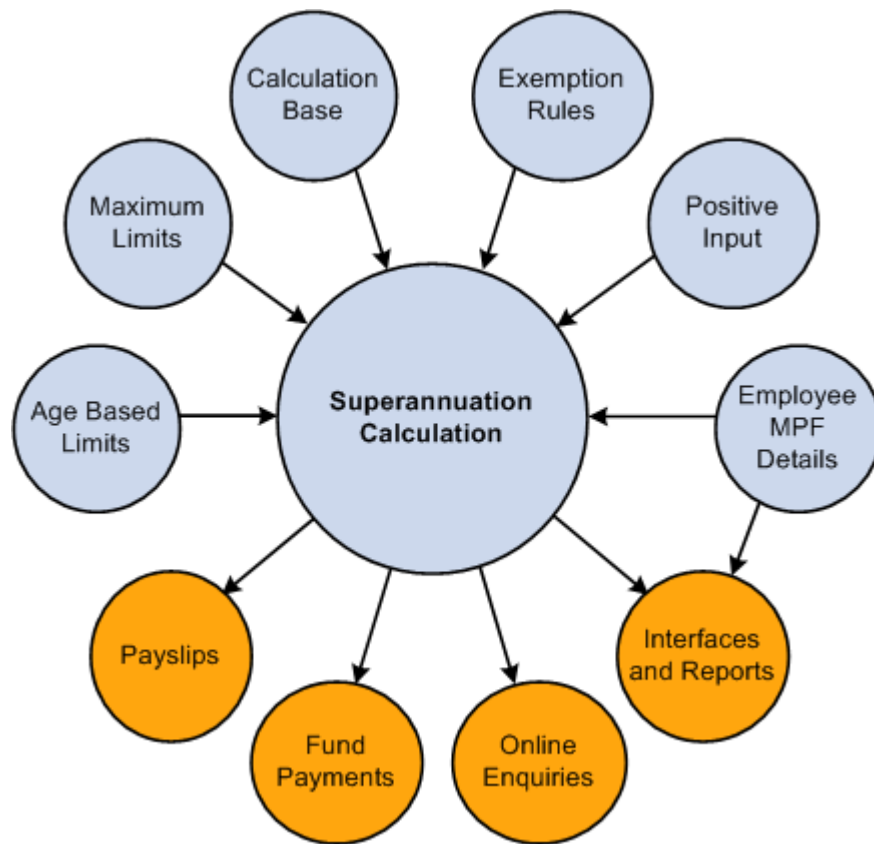

## Making Statutory and Customary Superannuation Deductions

The following deductions are for the common super contributions.

Deduction Name	Calculation Rule	Description
SGCMAN (super - mandatory) (Statutory)	Base × Percent	The superannuation guarantee (SG) contribution mandated by Australian legislation. Employers normally pay this on behalf of the employees. This is defined to be a percentage of the employee's actual gross earnings for the period. The PeopleSoft-delivered variable AUS VR SGCMAN PCT holds this user-maintainable value.

Deduction Name	Calculation Rule	Description
ER ADDLSPR (employer additional super) (Customary)	Base × Percent	The super contribution that the company pays in addition to the percentage mandated by the legislation. This is a percentage of the employee's actual gross earnings. The employer defines the value of the percentage. The PeopleSoft-delivered variable SUP VR ERADDL PCT holds this user-maintainable value.
EE SSSPR (employee salary sacrifice super) (Customary)	Base × Percent	The super contribution that an employee pays as a salary sacrifice. This is defined as a percentage of the employee's actual gross earnings. The percentage is entered at the payee level as a deduction assignment. Refer to the description of the ER MATCHSPR deduction.
AWARDMAN (award - mandatory) (Customary)	Amount	The super contribution likely to be used by award-based employees. It shows how super can be calculated using a tier-based calculation. With the amount being calculated from a formula SUP FM TIERBSD AMT
ER MATCHSPR (employer matching super) (Customary)	Base × Percent	The super contribution that the company voluntarily pays on behalf of an employee who contributes to super through salary sacrifice. This shows how a company can match the employee contribution. Only employees with EE SSSPR receive this deduction. Refer to the description of the EE SSSPR deduction.
EE SUPER (employee super) (Customary)	Amount	The super contribution that an employee pays as an after-tax deduction. This is defined as a flat amount. Employees need to be enrolled to have this deduction taken. The amount is entered at the payee level as a deduction assignment.

## Setting the Calculation Rule

Although a superannuation contribution can be a flat amount or the result of a tier-based calculation, most often it is a percentage of a base; for example, regular gross earnings, actual gross earnings, notional salary, super salary earnings, or compensation rate. The standard

element calculation rule options accommodate all the calculation methods applicable to superannuation deductions.

## Using Tier-Based Calculations

Tier-based calculation is typically used in the Australian public service and all participating commonwealth agencies. In this calculation, contributions are based on the employee's salary range and may be a flat amount or a percentage as illustrated in the following table:

Annual Salary	Annual Amount	Annual %
0.00 - 40,040.00	1,201.20	
40,041.00 - 64,514.58	An amount	3% of superannuation salary
64,514.59 - 96,772.00	1,935.44	
> 96,772.00		2% of superannuation salary

A user-maintained bracket, SUP BR TIERBSD TBL, stores these values. You can store both an amount and a percentage per range, as illustrated by the second row.

The system uses the annualized super salary (rate code AU SUPERSAL × system element RC FREQ FACTOR) to retrieve the flat amount or percentage to be applied. It then deannualizes the retrieved flat amount to the period frequency. The percentage, however, is applied to the period super salary, not the annualized period salary.

Although annualization and deannualization are normally automatic in the system, for this instance, the process is manual. The frequencies used for this process are stored at the pay group level.

## Using Percentage Based on Employee Contributions (Matching)

The percentage of the ER MATCHSPR deduction element is based on the percentage of the EE SSSPR deduction element. For example, a company might contribute an extra 1 percent for employees who are voluntarily contributing 1 to 2 percent through salary sacrifice, an extra 2 percent for employees contributing 3 to 4 percent, and an extra 3 percent for employees contributing 5 percent or more.

### Note

The EE SSSPR deduction element needs to be resolved before ER MATCHSPR, and ER MATCHSPR needs to be defined as *By Eligibility* so that it does not require a deduction assignment record.

A user-maintained bracket, SUP BR CMPNY PCT, stores the employee contribution ranges and the matching employer contribution. The deduction ER MATCHSPR uses this bracket to determine the percentage to use.

### Note

If the employee does not have a salary sacrifice super contribution, the resulting percentage from this bracket is 0 percent.

## Accommodating Exemption Rules and Limits

Although it is mandatory for employers to pay super contributions for each employee, the following exemptions exist:

- Employees who earn less than 450.00 AUD in a month.
- Employees who are 70 years old or over.
- Employees who are under 18 years old and work 30 hours or less in a week.
- Employees paid to do work of a domestic or private nature for no more than 30 hours a week.
- Nonresident employees paid for work done outside Australia.
- Resident employees paid by nonresident employers for work done outside Australia.
- Some foreign executives who would have been eligible for the previous class 413 (executive, overseas) visa or entry permit under Migration (1993) regulations.
- Employees who so elect because the benefit exceeds the pension reasonable benefits limit.

Only the first three rules are delivered with this country extension, because the other rules can be accommodated using the standard core employee earnings and deductions assignment functionality.

## Using Exemption Rule Checks

Because some employers still process super contributions for employees who fall into the first three of the exemption rules listed in the previous section, you need a way to specify whether the checks and limits apply or not. You achieve this using variables as supporting element overrides.

### Related Topics

- [Identifying Data for State Payroll Tax Reporting](#)  
Before you begin configuring Global Payroll to report payroll tax, you need to identify the earnings, deductions, benefits, and expenses that are subject to payroll tax. To do this, check with the state revenue office of each state in which the organization pays employees. After you have gathered this information, run the payroll routinely and process payroll tax.
- [Controlling Exemptions and Checking Limits](#)  
Supporting element overrides, set as variables at the deduction level, determine whether the checks occur and the limits are imposed. The following table shows the supporting elements and the values that you need to set.

## Applying Maximum Earnings Limits

Legislation provides an earnings ceiling that limits the amount an employer is required to contribute. This ceiling is indexed each year and as of July 1, 2009 was 40,170.00 AUD per quarter. Employers do not have to apply the limit, and they can continue to contribute for the employee's super.

The following table shows the reduced amount payable in the third month because the quarterly limit is reached in that month. The SG contribution is based on 9 percent in this example.

Month	Earnings	SG Calc'd On	Cumulative Amount / Month	SG Contribution
January	10,000	10,000	10,000	900
February	20,000	20,000	30,000	1800
March	10,000	5,240 (35,240 – 30,000)	35,240	471.60

This limit check is part of the SGCMAN deduction calculation. Variables determine whether the check occurs and the maximum limit. If the check occurs, the system verifies the employee's quarter-to-date gross earnings against the quarterly limit.

## Checking Age-Based Limits

These limits apply to employers claiming deductions from company tax liability for contributions made on behalf of their employees. You can have the system validate the total super deductions that an employer has paid for the employee against an age-related limit provided by the Australian Tax Office (ATO). A company might use this validation to restrict an employee's salary sacrifice deductions—because it cannot claim tax deductions for contributions above these limits.

Different age groups have different limits. These limits are indexed every year.

A user-maintained bracket, SUP BR AGEBSD LMT stores this data.

### Note

When you set the variable as a supporting element override to control this check, you must make sure that this deduction adds to the year-to-date (YTD) accumulator that the system uses for the validation. If the YTD accumulator is equal to the limit based on the employee's age, the system does not resolve the super contribution.

The system uses a separate deduction code to resolve the amount necessary to adjust the super contribution.

## Controlling Exemptions and Checking Limits

Supporting element overrides, set as variables at the deduction level, determine whether the checks occur and the limits are imposed. The following table shows the supporting elements and the values that you need to set.

The character value Y instructs the system to make the check. The minimum and maximum earnings limits require a second variable to hold the limit.

Exemption	Variable	Character Value	Amount Value
Minimum earnings	SUP VR MINEARN YN	Y	
Minimum earnings	SUP VR MINERN AMT		<i>Applicable Limit</i>
Age 70 and over	SUP VR 70&OVER YN	Y	

Exemption	Variable	Character Value	Amount Value
Age under 18, and work 30 or less hours per week	SUP VR UNDER18 YN	Y	
Maximum earnings limits	SUP VR MAXEARN YN	Y	
Maximum earnings limits	SUP VR MAXEARN AMT		<i>Applicable Limit</i>
Age-based limits	SUP VR AGEBSD	Y	

## Accommodating Employee Options

There are a number of employee options related to superannuation that are met by core functionality. Here is a summary of the options and how they are accommodated:

- **Override deduction recipient record.**  
Global Payroll enables, at the payee level, the overriding of the recipient record set at deduction level (select **Home**, and then **Compensate Employees**, and then **Manage Global Payroll Data**, and then **Use**, and then **Deduction Recipients**).
- **Override percentages and amount.**  
Global Payroll enables the overriding of percentages and amounts at different levels. Once set at the deduction level, they can be overridden at the payee deduction assignment level and at the positive input level.
- **Automatic assignment of employees to super funds.**  
When the deduction element is defined as *By Eligibility Group*, employees belonging to the eligibility group automatically have the deduction element, as if the employees were enrolled in the deduction.
- **Employee's super salary.**  
This can be stored in the system using the Multiple Components of Pay feature.
- **Employee's super fund membership ID.**  
The GPAU\_RCPYE\_EXT page captures this information. The page includes a **Membership ID** field, where you can enter the identifier that the recipient has assigned to the payee.

### Related Topics

- [Setting Up Additional Deduction Recipient Information](#)  
To set up additional deduction recipient information, use the Deduction Recipients AUS (GPAU\_RECIPIENT) component.

## Displaying Superannuation Information on the Payslip

Australian law requires that payslips must display the superannuation fund name for any superannuation fund deductions, and they must display the membership ID number.

To display the superannuation fund name, access the Earnings and Deductions page (select **Set Up HCM**, and then **Product Related**, and then **Global Payroll & Absence Mgmt**, and then **Payslips**, and then **Templates AUS**). On the **Element Components** tab, select *Recipient Name* from the **Description Type** list for the related deduction element.

To display the membership number on the payslip, access the Earnings and Deductions page (select **Set Up HCM**, and then **Product Related**, and then **Global Payroll & Absence Mgmt**, and then **Payslips**, and then **Templates AUS**). On the **Element Details** tab, select **Display Membership ID** for the related deduction element.

## Creating the ComSuper Payroll Interface File

This topic provides an overview of the Payroll Interface File (PIF) and discusses how to generate the PIF.

### Pages Used to Create the ComSuper Payroll Interface File

Page Name	Definition Name	Usage
<a href="#">Create Super Rpt File Page</a>	GPAU_RC_SUPEREC	Generate the PIF for delivery to ComSuper.
Deduction Recipient List Page	GPAU_SUPEC_RCP_RC	Add deduction recipients to be included in the PIF.

### Payroll Interface File

ComSuper provides an online superannuation service that enables employers to submit, correct, and validate superannuation data using a secure online login. ComSuper worked with employers and payroll providers to replace the Superannuation Exceptions Data (SED) and Continuous Contributions Data (CCD) files with a single file—the Payroll Interface File. Global Payroll for Australia enables you to define PIF data and generate the PIF for delivery to ComSuper.

To define and generate the PIF:

1. Set up a deduction recipient as a Super Fund Administrator on the Deduction Recipients page. Select a Super Reporting Format and ComSuper Agency ID for that deduction recipient. Ensure that the correct pay entity is added to the deduction recipient.  
Enter all required SuperEC information on the SuperEC Detail page.
2. Access the Deduction Recipient page using the Super Reporting link on the Payee Recipient page. Enter all required Super Reporting information.
3. Ensure that the TFN Disclose to Superannuation check box is selected on the Payee Tax Data page for all employees to be included in the PIF.
4. Run and finalize the calendar groups for which you are generating the PIF.
5. Run and finalize the payment preparation process for the calendar groups to be included in PIF.
6. Generate the PIF using the Create Super Rpt File run control page.

#### Related Topics

- [Setting Up Additional Deduction Recipient Information](#)  
To set up additional deduction recipient information, use the Deduction Recipients AUS (GPAU\_RECIPIENT) component.
- PeopleSoft Global Payroll: Run Payment Prep Process Page

- [Fund Transfer - Electronic Page](#)  
Use the Fund Transfer - Electronic page (GPAU\_EFT\_CMX) to enter the parameters for the electronic file creation.

## Create Super Rpt File Page

Use the Create Super Rpt File page (GPAU\_RC\_SUPEREC) to generate the PIF for delivery to ComSuper.

Navigation:

**Global Payroll & Absence Mgmt**, and then **Authority Correspondence**, and then **Create Super Report File AUS**, and then **Create Super Rpt File AUS**

This example illustrates the fields and controls on the Create Super Rpt File AUS page. You can find definitions for the fields and controls later on this page.

The screenshot shows the 'Create Super Rpt File AUS' page with the following fields and controls:

- Report Type:** Radio buttons for ComSuper (selected), SuperEC, and Agest.
- Test Indicator:** Checkboxes for Acknowledgement (checked) and Test Indicator.
- Date Range or Cal Group ID:**
  - \*Date From: 04/01/2006
  - \*Date To: 04/30/2006
  - Calendar Group ID: KAM200604
- Pay Entity:** \*Pay Entity: KAAUSBI (Australian Business Institute), Deduction Recipient AUS List.
- ComSuper:** Payroll Run Number: 1.

### Report Type

Select the type of report you are creating. You can use this page to generate a report file for **ComSuper**, **SuperEC**, or **Agest**.

### Placeholder

Field or Control	Description
<b>Date From and Date To</b>	Enter a date range for the report file. The system populates these fields automatically if you select a calendar group in the Calendar Group ID field.
<b>Calendar Group ID</b>	Select the calendar group to be included in the report file.

**Note**

If you generate the EFT payment file before running this process, the calendar group for which you created the EFT payment file will not be available in the Calendar Group ID field. You must use enter a date range for the PIF file in that case.

**Test Indicator**

Field or Control	Description
<b>Acknowledgement</b>	Select to receive an acknowledgement after sending a SuperEC message file.
<b>Test Indicator</b>	Select to indicate that the SuperEC message file that you are creating is for test purposes only.

**Pay Entity**

Field or Control	Description
<b>Pay Entity</b>	Select the pay entity to be included in the report file.
<b>Deduction Recipient AUS List</b>	Click to access the Deduction Recipient List where you can add deduction recipients to the report file.

## Creating the SuperStream Files

SuperStream Standard for Contributions is a new electronic standard for processing superannuation contributions. It is introduced by the Australian Taxation Office (ATO) and provides a streamlined approach for employers and superannuation funds to send and receive superannuation data and payments electronically. It is applicable for the Private, Commonwealth Superannuation Schemes (CSS), Public Sector Superannuation (PSS) Schemes, and the Public Sector Superannuation Accumulation Plans (PSSap).

To meet the standard, employers need to send prescribed data to superannuation funds electronically. SuperStream supports XBRL (eXtensible Business Reporting Language), SAFF (SuperStream Alternate File Format ) and SAFFE (Superannuation Alternate File Format Extended ) file formats. For CSS and PSS, employers can also submit superannuation data using Employer Services Online (ESO).

Global Payroll for Australia enables you to create files based on SuperStream Data and Payment Standard. There are multiple Super Annuity schemes available for employees, based on the organizations they work for. The generic SuperStream report page (Create SuperStream Files AUS Page) is used for non-psu and non- defence funds while CSS/PSS/ PSSap page(ComSuper SS Reporting File AUS Page) is to generate report for public sector schemes.

## Pages Used to setup and create the SuperStream Files

Page Name	Definition Name	Usage
<a href="#">Deduction Recipients AUS Page</a>	GPAU_RECIPIENT_EXT	Configure the recipient to a unique Super Fund.
<a href="#">SuperEC Detail Page</a>	GPAU_RECIPNT_SPREC	Enter receiver, target fund, and sender information according to SuperStream standards.
<a href="#">SuperStream Third Parties AUS Page</a>	GPAU_THRD_PRTY_DTL	Define any third-party which can act as a payer.
<a href="#">Pay Entities AUS Page</a>	GPAU_PYENT_EXT	Specify the pay entity details.
<a href="#">Third Party Detail Page</a>	GPAU_PYENT_EXT1	Define entities that would be acting as a Payer for the organization.
<a href="#">Recipient Details Page</a>	GPAU_PYENT_EXT2	Provide CRN/ Super Employer ID details of the recipient.
<a href="#">Add Deduction Recipients AUS Page</a>	GPAU_RCPPE_EXT	Configure Superannuation Fund Member related information
<a href="#">Create SuperStream Files AUS Page</a>	GPAU_RC_SS_REPORTS	Generate the CSV/XBRL file containing the Superannuation registration/contribution details for the employees in the organization.
<a href="#">Create ComSuper SS Report Files AUS Page</a>	GPAU_RC_COM_REPORT	Generate SAFFE (SAFF for PSSap)/ XBRL file containing the Superannuation registration/contribution details for the employees in the organization.

## SuperStream Third Parties AUS Page

Use the SuperStream Third Parties AUS page (GPAU\_THRD\_PRTY\_DTL) to define any third-party which can act as a payer.

Navigation:

**Setup HCM**, and then **Product Related**, and then **Global Payroll & Absence Mgmt**, and then **Reports**, and then **SuperStream Third Parties AUS**

SuperStream Third Parties AUS Page

## SuperStream Third Parties AUS

Third Party ID 44444

Third Party Details Find | View All First 1 of 1 Last

Effective Date 01/01/2000 Effective Status Active

Clearing House Lodgement Number STATICLRNNO1234

Organization Name COMSUPER CLEARING HOUSE

ABN 4050607080

USI 404505606

Contact ID 00009

Source Bank ID KA02 ANZ Recipient Account (AUS)

Field or Control	Description
<b>Effective Status</b>	Select the status as active or inactive
<b>Clearing House</b>	Select this check box if a clearing house is used by the employer as the third party to manage their employee super fund contributions.
<b>Lodgement Number</b>	Enter the lodgement number. <b>Note:</b> This field appears only when Clearing House check box is selected.
<b>Organisation Name</b>	Name of the organization that makes the payment.
<b>ABN</b>	ABN of the payer.
<b>USI</b>	Enter the Unique Superannuation Identifier (USI) of the payer. <b>Note:</b> If ABN is provided, then this field is not mandatory.
<b>Contact ID</b>	Select the ID of the contact person. <b>Note:</b> For this purpose the user should have already added a person (Add a Person) within the Workforce Administration > Personal Information section identifying the person as POI (Person of Interest).
<b>Source Bank ID</b>	Select the Source Bank ID of the organization that makes the payment.

If a clearing house is used by the employer to manage their employee super fund contributions, the clearing house needs to be added as a third party.

To add a clearing house as third party, you need to:

- Define a Deduction Recipient (Recipient ID) under General Category with Payment method as 'Bank Transfer', using the Define Deduction Recipients page.
- Define a Third Party (Third Party ID same as the defined Recipient ID), using SuperStream Third Parties AUS page.

And, also select the Clearing House check box and enter the Lodgement Number while defining a clearing house as the third party.

## Pay Entities AUS Page

Use the Pay Entities AUS page (GPAU\_PYENT\_EXT) to define Employer related details to be used in Superannuation reporting with the Australian authorities

Navigation:

**Setup HCM**, and then **Product Related**, and then **Global Payroll & Absence Mgmt**, and then **Framework**, and then **Organizational**, and then **Pay Entities AUS**

### Pay Entities AUS page

The screenshot displays the 'Pay Entities AUS' configuration page. At the top, there are tabs for 'PayEntity Details', 'ThirdParty Detail', and 'Recipient Details'. The main title is 'Pay Entities AUS'. Below this, the 'Pay Entity' is identified as 'KAAUSBI' (Australian Business Institute). The 'Pay Entity Defaults' section is active, showing a list of records with '1 of 1' records displayed. The record details include:

- Effective Date: 01/01/1980
- Australian Details:
  - Trading Name: AUSTRALIAN BUSINESS INSTITUTE
  - Registered Name: AUSTRALIAN BUSINESS INSTITUTE
  - Telephone: 02 9413 0000
  - Phone Extension: 2036
  - Fax Number: (empty)
  - Industry: (empty)
  - Tax Contact ID: KA3012 (with search icon and 'Julia Hills' text)
  - Signatory: JULIA HILLS
  - ABN: 91456789123
  - ABN Branch: 2
  - ATO Office Code: 70
  - EFT Code: 002914567891237570
  - Email Address: (empty)
  - Error Handling Enabled
  - E-Service Address: kaausbieserv@email.com

Field or Control	Description
<b>Trading Name</b>	Enter the trading name of the organization that makes the payment. <b>Note:</b> If the Pay Entity itself is the Payer, then this value will be the Pay Entity Trading Name, else from the field Organization Name as defined in the "Third Party Detail" tab.
<b>Registered Name</b>	Enter the registered name of the organization that makes the payment.
<b>Tax Contact ID</b>	Contact details of pay entities authorized representative.
<b>Signatory</b>	Authorised Signatory

Field or Control	Description
<b>ABN</b>	Australian Business Number (ABN) of the employer/ organisation that makes the payment.
<b>ABN Branch</b>	Pay entities Individual ABN branch details.
<b>ATO Office Code</b>	Enter Australian Taxation Office (ATO) code.
<b>EFT Code</b>	Enter the Electronic Fund Transfer (EFT) code
<b>Error Handling Enabled</b>	Select the check box if the organisation is capable of decoding the member registration/ contribution error responses generated by the target system
<b>E-Service Address</b>	Enter the e-service url, if you have selected the Error Handling Enabled check box.

## Third Party Detail Page

Use the Third Party Detail page (GPAU\_PYENT\_EXT1) to define entities that would be acting as a Payer for your organization.

Navigation:

**Setup HCM**, and then **Product Related**, and then **Global Payroll & Absence Mgmt**, and then **Framework**, and then **Organizational**, and then **Pay Entities AUS**

Third Party Detail page

Field or Control	Description
<b>Organisation Link Option</b>	Select from the following options: <i>Pay Group</i> <i>Recipient</i>

Field or Control	Description
<b>Organisation Unit</b>	Select the organisation unit. List of selection will be based on the value selected in Organisation Link Option field. <b>Note:</b> You can define only one row for each Third Party Type for an Organization Unit selected
<b>Third Party Type</b>	Select from the following options: <i>Payer</i> <i>Clr House</i>
<b>Pay Entity</b>	Select this checkbox if the selected organization acts as the Pay Entity.
<b>Third Party ID</b>	Select the Third Party ID. <b>Note:</b> On selecting Pay Entity check box, this field will be disabled.
<b>Organisation Name</b>	The name of the “Payer” that will be printed in the “SuperStream” report.

If a clearing house needs to be added as the third party (**‘Recipient’ as Organization Link Option**):

- Under Pay Entities AUS component, load all the recipients and assign the clearing House as a third-party for the recipients which contribute to Clearing House.
- Set the third Party type to ‘Clr House’ to select a clearing house.
- If third-party type is ‘Clr House’, but the ‘Third-party ID’ selected does not have Clearing House flag selected on the third-party definition, then the configuration of clearing house is ignored.
- The recipient can be either General or Individual.
- ‘Load All Organization Units’ will load the recipients which are configured to be of ComSuper/SuperStream reporting format under ‘Deduction Recipients Aus’ component.

With this configuration, EFT process will club all the payments of the recipients (with Super Reporting Format set to SuperStream File Format or Com Super File Format in Deduction Recipients AUS component) in to one and make the payment to Clearing House.

If a clearing house needs to be added as a third party (**‘Pay Group’ as Organization Link Option**):

- Under Pay Entities AUS component, load all the Pay Groups and assign the clearing House as a third-party for the Pay Groups which contribute to Clearing House.
- Set the third Party type to ‘Clr House’ to select a clearing house.
- If third-party type is ‘Clr House’, but the ‘Third-party ID’ selected does not have Clearing House flag selected on the third-party definition, then the configuration of clearing house is ignored.

With this configuration, EFT process will club all the payments of the recipients (with Super Reporting Format set to SuperStream File Format or Com Super File Format in Deduction Recipients AUS component) under the Pay Group with clearing House in to one and make the payment to Clearing House. Any payments to a recipient with other Super Reporting Formats will continue to be paid to the corresponding recipient.

## Recipient Details Page

Use the Recipient Details page (GPAU\_PYENT\_EXT2) to provide CRN/ Super Employer ID details of the recipient.

Navigation:

**Setup HCM**, and then **Product Related**, and then **Global Payroll & Absence Mgmt**, and then **Framework**, and then **Organizational**, and then **Pay Entities AUS**

This example illustrates the fields and controls on the Recipient Details page. You can find definitions for the fields and controls later on this page.

### Recipient Details Page

Field or Control	Description
<b>Customer Reference Number</b>	In the case of a BPAY payment, the payment reference number is the customer reference number as issued by, or on behalf of, the relevant superannuation entity.
<b>Super Employer ID</b>	Enter the Employer Identifier.

## Add Deduction Recipients AUS Page

Use the Add Deduction Recipient AUS page (GPAU\_RCPPYE\_EXT) to configure Superannuation Fund Member related information (Fund Member is the employee in your organization who makes Superannuation contributions to the various Super Funds)..

Navigation:

**Global Payroll & Absence Mgmt**, and then **Payee Data**, and then **Net Pay / Recipient Elections**, and then **Add Deduction Recipients AUS**

Add Deduction Recipients AUS page

**Add Deduction Recipients AUS**

Employee ID KUL907      Empl Record 0      Name Caroline Austine

Recipient Details      Find | View All      First 1 of 1 Last

\*Recipient ID  🔍

\*Effective Date 11/02/2016 📅

Super Reporting

Deduction List      Personalize | Find | 📄 | 📅      First 1 of 1 Last

Membership ID	*Element Name
1 <input type="text"/>	<input type="text"/> 🔍

On clicking the Super Reporting Link, Deduction Recipient page is displayed. Based on the selected Super Reporting Format of the Deduction Recipient ID, the fields under Deduction Recipient section changes to accommodate the requisite super fund member details.

## Create SuperStream Files AUS Page

Use the Create SuperStream Files AUS page (GPAU\_RC\_SS\_REPORTS) to generate the CSV file containing the Superannuation registration/contribution details for the employees in your organization.

Navigation:

**Global Payroll & Absence Mgmt**, and then **Authority Correspondence**, and then **Create SuperStreamt Files AUS**

Create SuperStream Files AUS page

## Create SuperStream Files AUS

Run Control ID 001

Report Manager

Process Monitor

Run

**Date Range or Cal Group ID**

\*Calendar Group ID  🔍

\*Pay Entity  🔍

Negatives Allowed

Deduction Recipient AUS List

File Generation Option   Generate Single CSV

Registration XML Set  🔍      Registration XML Template  🔍

Contribution XML Set  🔍      Contribution XML Template  🔍

XBRL File Path

URL Identifier  🔍

Field or Control	Description
<b>Calendar Group ID</b>	Choose the Calendar Group. The calendar group should be finalized and the banking process completed.
<b>Pay Entity</b>	Choose the Pay Entity.
<b>Negatives Allowed</b>	This value is checked to denote that the entity receiving the CSV files is capable of handling any negative values present in the CSV file being generated to report the Superannuation contribution details for the employees in your organization. This value cannot be edited.
<b>Deductions Recipients AUS List</b>	Filter the output results can by selecting specific Deduction Recipients.
<b>File Generation Option</b>	One CSV file for every unique combination of Sender/Receiver/Payer/Payee as determined by the program is generated based on your organization's data setup at the Deduction Recipient AUS page and the Pay Entity AUS page and the specified run control parameters. Two other file generation options are also provided to generate XBRL file or both XBRL and CSV files;XBRL Only and CSV & XBRL.
<b>Generate Single CSV</b>	Generate Single CSV is displayed when the file generation option is either CSV Only or CSV & XBRL. Generate Single CSV is unchecked by default. Checking this box would create a single CSV file for all the deduction recipients. Unchecking creates one CSV file for each deduction recipient and lodgment reference number combination.

When XBRL Only or CSV & XBRL options are chosen multiple fields are displayed to capture the XML framework details required to create XBRL file. XBRL File Path provided should be a path accessible to the process scheduler server. The XBRL file created is posted to the path provided in URL Identifier

## Create ComSuper SS Report Files AUS Page

Use the Create ComSuper SS Reports AUS page (GPAU\_RC\_COM\_REPORT) to generate SAFFE (.CSV or .XBRL) file containing the Superannuation registration/contribution details for the employees in your organization.

Navigation:

**Global Payroll & Absence Mgmt**, and then **Authority Correspondence**, and then **Create ComSuper SS Report Files AUS**

Create ComSuper SS Report Files - CSV format

### Create ComSuper SS Report Files AUS

Run Control ID Payroll Report Manager Process Monitor

**Date Range or Cal Group ID**

\*Calendar Group ID   From 01/01/2014 To 01/31/2014

\*Pay Entity   Australian Business Institute

Negatives Allowed

Deduction Recipient AUS List

File Generation Option   Generate Single CSV

URL Identifier

Create ComSuper SS Report Files - XBRL format

## Create ComSuper SS Report Files AUS

Run Control ID Payroll

Report Manager

Process Monitor

Run

**Date Range or Cal Group ID**

\*Calendar Group ID   From 01/01/2014 To 01/31/2014

\*Pay Entity   Australian Business Institute

Negatives Allowed

Deduction Recipient AUS List

File Generation Option  ▾

**Com Super Reporting**

Registration XML Set   Registration XML Template

Contribution XML Set   Contribution XML Template

XBRL File Path

URL Identifier

Field or Control	Description
<b>Calendar Group ID</b>	Choose the Calendar Group.
<b>Pay Entity</b>	Choose the Pay Entity.
<b>Negatives Allowed</b>	This value is checked to denote that the entity receiving the CSV files is capable of handling any negative values present in the CSV file being generated to report the Superannuation contribution details for the employees in your organization. This value cannot be edited.
<b>Deductions Recipients AUS List</b>	Filter the output results can by selecting specific Deduction Recipients.
<b>File Generation Option</b>	One CSV file for every unique combination of Sender/Receiver/Payer/Payee as determined by the program is generated based on your organization's data setup at the Deduction Recipient AUS page and the Pay Entity AUS page and the specified run control parameters. Two other file generation options are also provided to generate XBRL file or both XBRL and CSV files;XBRL Only and CSV & XBRL.
<b>Generate Single CSV</b>	Generate Single CSV is displayed when the file generation option is either CSV Only or CSV & XBRL. Generate Single CSV is unchecked by default. Checking this box would create a single CSV file for all the deduction recipients. Unchecking creates one CSV file for each deduction recipient and lodgment reference number combination.

---

Field or Control	Description
<b>ComSuper Reporting</b>	This group box appears when XBRL Only or CSV & XBRL options are chosen. This captures the XML framework details required to create XBRL file. XBRL File Path provided should be a path accessible to the process scheduler server. The XBRL file created is posted to the path provided in URL Identifier.

---

# Running Banking and Recipient Processes

## Understanding Banking and Recipient Processing

The banking process of Global Payroll combines payroll data, pay entity source bank data, and payee or recipient bank data. The EFT file creation process extracts data compiled by the banking process according to the type of EFT file that you are creating, merges it with data provided by the Australian country extension, and creates the file for transmission.

### Note

In these topics, the payee of group tax is the Australian Tax Office (ATO). The ATO is a recipient just as a health fund or the beneficiary of a garnishment is a recipient. Unless otherwise stated, the term *recipient* includes the ATO.

## Setting Up Additional Deduction Recipient Information

To set up additional deduction recipient information, use the Deduction Recipients AUS (GPAU\_RECIPIENT) component.

This topic discusses ways to set up additional deduction recipient information.

### Note

Use the Deduction Recipients AUS page only if you need to attach membership information to deduction elements. Otherwise, use the generic Add Deduction Recipients page.

## Pages Used to Set Up Additional Deduction Recipient Information

Page Name	Definition Name	Usage
<a href="#">Add Deduction Recipients AUS Page</a>	GPAU_RCPPYE_EXT	Link a payee to a deduction recipient and enter the payee's membership number with that recipient.
Deduction Recipient Page	GPAU_RCPPYE_SUPER	Enter Super Reporting details for the payee.
<a href="#">Deduction Recipients AUS Page</a>	GPAU_RECIPIENT_EXT	Enter Australia-specific additional information about recipients that are set up in the core application for Global Payroll.

Page Name	Definition Name	Usage
<a href="#">Setting Up Additional Deduction Recipient Information</a>	GPAU_RECIPNT_SPREC	Enter receiver, target fund, and sender information according to SuperEC standards.

## Add Deduction Recipients AUS Page

Use the Add Deduction Recipients AUS page (GPAU\_RCPPYE\_EXT) to link a payee to a deduction recipient and enter the payee's membership number with that recipient.

Navigation:

**Global Payroll & Absence Mgmt**, and then **Payee Data**, and then **Net Pay / Recipient Elections**, and then **Add Deduction Recipients AUS**, and then **Add Deduction Recipients AUS**

This example illustrates the fields and controls on the Add Deduction Recipients AUS page. You can find definitions for the fields and controls later on this page.

Field or Control	Description
<b>Recipient ID</b>	Identifier for the recipient of the deduction element.
<b>Membership ID</b>	Membership ID associated with the recipient ID.
<b>Element Name</b>	Name of the deduction element.

## Deduction Recipients AUS Page

Use the Deduction Recipients AUS page (GPAU\_RECIPIENT\_EXT) to enter Australia-specific additional information about recipients that are set up in the core application for Global Payroll.

Navigation:

**Set Up HCM**, and then **Product Related**, and then **Global Payroll & Absence Mgmt**, and then **Banking**, and then **Deduction Recipients AUS**

This example illustrates the fields and controls on the Deduction Recipients AUS page. You can find definitions for the fields and controls later on this page.

This example illustrates the fields and controls on the Deduction Recipients AUS page. You can find definitions for the fields and controls later on this page.

Deduction Recipients AUS

**Field or Control**

**Description**

**Group Tax Recipient**

Select if the recipient is the ATO, the recipient of group tax.

**File Layout**

Select the appropriate file layout from those that you have created in Application Designer for report files that you submit to recipients. When you run the Recipient File - Electronic report, the Application Engine process uses the file layout that you enter here.

**Note:** The GPAU\_RCPFILE Application Engine process uses only the GPAU\_RCPNT FILE recipient schedule file. You can make minor changes to that file—for example, field order. However, if you make major file layout changes, you must create additional Application Engine programs to process them.

**Note**

The lodgment reference for net pay is the employee ID plus payment date. For recipient payments, it is the group number plus payment date. For group tax payments, it is the EFT code plus payment date.

**Super Reporting**

Field or Control	Description
<b>Super Fund Administrator</b>	Select to designate the recipient as a Super Fund administrator. <b>Note:</b> This field is not visible when 'SuperStream File Format' is selected as the Super Reporting Format.
<b>Super EC</b>	Click to access the SuperEC Detail page.
<b>Super Reporting Format</b>	Select a reporting format. Valid values are Agest, ComSuper File Format, SuperEC file Format and SuperStream File Format. When you select SuperStream File Format for the respective Super Fund scheme. Deduction Recipients AUS page refreshes to display Payment Method field. If ComSuper File Format is selected, a new check box with Enable SuperStream and the chosen Payment Method Direct Credit become visible. The Enable SuperStream flag is set to True by default. This flag enables the recipient for SuperStream report. If the flag is set to False, the deduction recipient cannot be processed for SuperStream report and will be available only for PIF format file generation.
<b>Payment Method</b>	The payment method being used to transfer the superannuation contributions to the Super Fund. Select the payment method from the following options: <i>BPAY:</i> Select "BPAY" if the Deduction Recipient (Super Fund / Scheme) is paid using the BPAY facility. If payment is made using BPAY, the employer must include the Biller Code and the Customer Reference Number. <i>DirectCredit:</i> Select DirectCredit if the Deduction Recipient (Super Fund / Scheme) is paid using the DirectCredit facility. <i>DirectDebit:</i> Select DirectCredit if the Deduction Recipient (Super Fund / Scheme) is paid using the DirectDebit facility. <b>Note:</b> This field appears only when 'SuperStream File Format' is selected as the Super Reporting Format.
<b>ComSuper Agency ID</b>	Enter the ComSuper agency ID. <b>Note:</b> This field is not visible when 'SuperStream File Format' is selected as the Super Reporting Format.

**Details**

<b>Field or Control</b>	<b>Description</b>
<b>Pay Entity</b>	Enter the pay entity that receives this commission. If the commission is deducted from the payment due to the recipient, the debit to the pay entity's source bank account is reduced by the commission amount.
<b>Calculate Optn</b> (calculate option)	Select from the following values: <i>Ded Comm</i> (deduct commission): The system deducts the commission amount from the payment due to the recipient. <i>Rpt Only</i> (report only): The system reports the commission amount in the EFT file but does not deduct it from the payment.
<b>Type</b>	Select <i>Flat Amt</i> (flat amount) or <i>Percentage</i> .
<b>Amount</b>	Enter the flat amount or percentage to be calculated.
<b>Group Number</b>	Enter the unique identifier that the recipient has supplied for the pay entity. For payment to recipients <i>excluding</i> the group tax recipient and payee level recipients, the group number is part of the unique lodgment reference that is part of each recipient EFT file.

## SuperEC Detail Page

Use the Super EC link available in Deduction Recipients AUS page to navigate to the SuperEC Detail secondary page to setup Sender/Receiver/Target Fund information for the Deduction Recipient

SuperEC Detail page



Field or Control	Description
<b>Receiver ABN</b>	Enter the Australian Business Number (ABN) of the receiver. <b>Note:</b> This field appears only when 'SuperStream File Format or ComSuper File Format' is selected as the Super Reporting Format.
<b>Receiver Name</b>	Enter the Organization Name of the Message Receiver. <b>Note:</b> This field appears only when 'SuperStream File Format or ComSuper File Format' is selected as the Super Reporting Format.
<b>Email Address</b>	Enter the email address of the Message Receiver.

### Target Fund

This section contains details of the Super Fund Organization and the Super Fund Scheme Product ID.

Field or Control	Description
<b>Target Fund ABN</b>	Enter the Australian Business Number (ABN) of the Super Fund Organization.
<b>Target Product ID</b>	Enter the Super Fund USI.
<b>Target Fund Name</b>	Enter the fund name.
<b>Biller Code</b>	Enter the Biller Code of the Super Fund. <b>Note:</b> This field is applicable only for BPAY payment transactions.
<b>E-Service Address</b>	Enter the 'E-Service Address' field to specify the Electronic Service Address of the Super Fund scheme. <b>Note:</b> This field appears only when 'SuperStream File Format or ComSuper File Format' is selected as the Super Reporting Format.

### Sender

Field or Control	Description
<b>Pay Entity</b>	Check the Pay Entity check box to indicate if the Pay Entity is the sender of the file. If checked, the AE program GPAU_COM_RPT will fetch and load the Pay Entity's details in places where 'Sender' information is to be reported.

Field or Control	Description
<b>Error Handling Enabled</b>	Select the check box if the 'Sender' of the file is capable of decoding the member registration/contribution error responses generated by the target system. <b>Note:</b> This field appears only when 'SuperStream File Format or ComSuper File Format' is selected as the Super Reporting Format.
<b>Sender ID</b>	Enter the ID of the sender.
<b>Sender ABN</b>	Enter the Sender ABN
<b>Sender Name</b>	Enter the name of the sender.
<b>Sender Email</b>	Enter the email address of the sender.
<b>Contact ID</b>	Select the ID of the contact person. <b>Note:</b> For this purpose the user should have already added a person (Add a Person) within the Workforce Administration > Personal Information section identifying the person as POI (Person of Interest).

You can use the Edit Address option to edit the saved address of the sender.

## Managing Electronic Fund Transfers

This topic discusses ways to manage electronic fund transfers.

The Australian standard Cemtex file for EFT is created by a process that provides multiple options to control the file's content.

This diagram shows the tables that contribute data to the Cemtex file that is incorporated into the EFT file.

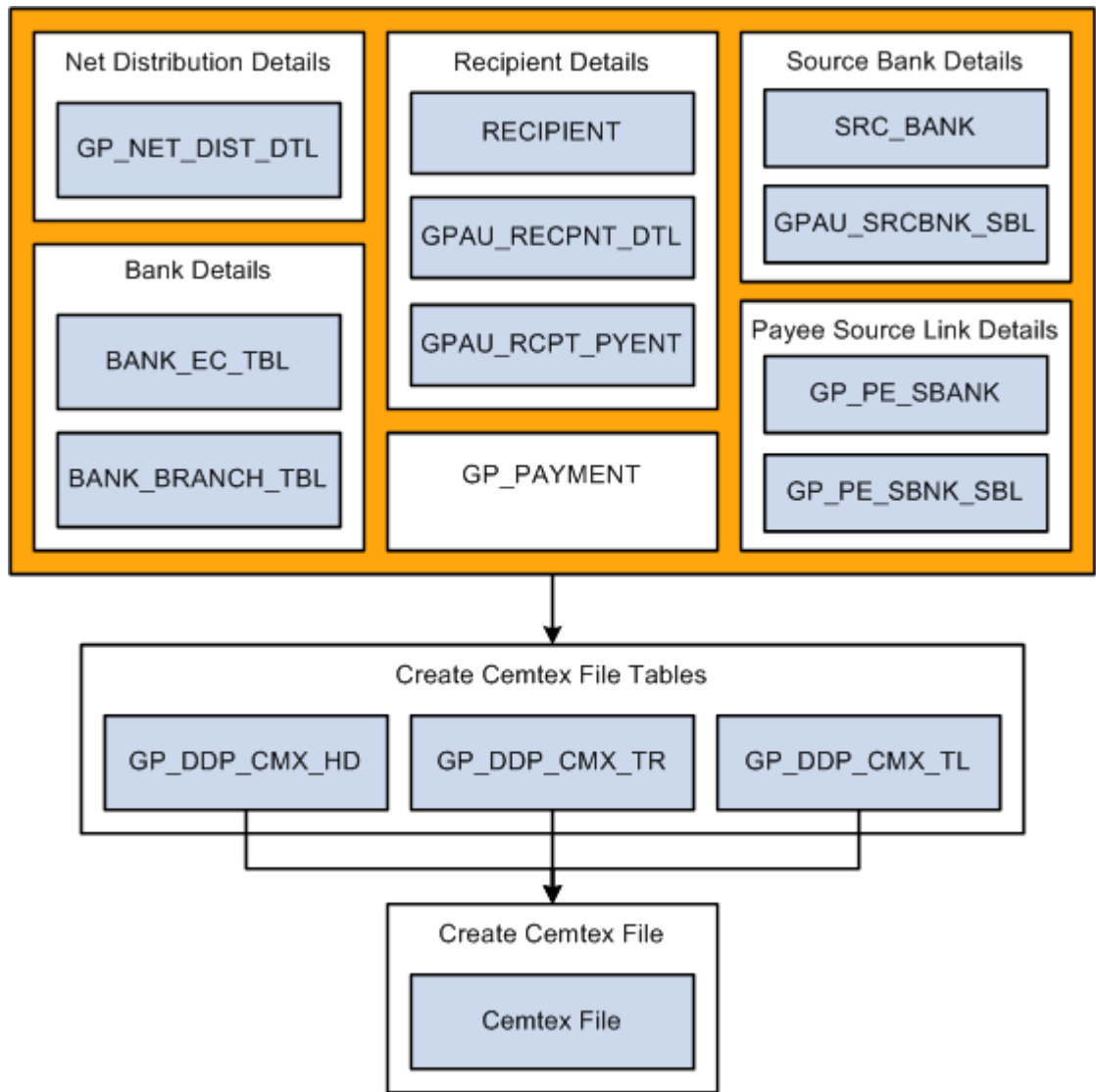

**Note**

You must finalize the Banking process (GP\_PMT\_PREPARE) before you can create the Cemtex file. After the Cemtex file is created, the system changes the PMT\_STATUS field in the GP\_PAYMENT table from *P* (prepared) to *T* (transferred).

## Page Used to Manage Electronic Fund Transfers

Page Name	Definition Name	Usage
<a href="#">Fund Transfer - Electronic Page</a>	GPAU_EFT_CMX	Enter the parameters for the electronic file creation.

## Generating the EFT Code

The system enters the pay entity's EFT code in the header of group tax EFTs as part of the lodgment reference. (The payment date makes each lodgment reference unique to a particular EFT file.)

The pay entity's EFT code is calculated by the system from your ABN, ABN branch, and ATO office code when you enter that information on the Pay Entities AUS page (select **Set Up HCM**, and then **Product Related**, and then **Global Payroll & Absence Mgmt**, and then **Framework**, and then **Organizational**, and then **Pay Entities AUS**). After it is calculated, the system displays it on that page. You cannot change the EFT code directly, but the system recalculates and displays it again if you change the ABN, branch, or office code.

## Fund Transfer - Electronic Page

Use the Fund Transfer - Electronic page (GPAU\_EFT\_CMX) to enter the parameters for the electronic file creation.

Navigation:

**Global Payroll & Absence Mgmt**, and then **Payment Processing**, and then **Create EFT Payment File AUS**, and then **Create EFT Payment File AUS**

This example illustrates the fields and controls on the Create EFT Payment File AUS page. You can find definitions for the fields and controls later on this page.

The screenshot displays the 'Create EFT Payment File AUS' page. At the top, there are navigation links: 'Run Control ID 001', 'Report Manager', 'Process Monitor', and a 'Run' button. Below this is a 'Definition' section containing several fields:

- Payment Type:** A dropdown menu set to 'Net Pay Distribution Only'.
- \*Entry Description:** A text field containing 'PAYROLL'.
- Calendar Group ID:** A text field with 'KAM03M05' and a magnifying glass icon. To its right, it says 'May Monthly Payroll 2003'.
- Stream Number:** A text field with a magnifying glass icon.
- Process Streams:** A checkbox that is currently unchecked.
- \*Payment Date:** A date field with '01/05/2003' and a calendar icon.
- Debit Date:** A date field with a magnifying glass icon.
- Period End Date:** A date field with '01/31/2003' and a calendar icon.
- Recipient Calculate Option:** A dropdown menu set to 'All Recipients'.
- Recipient ID:** A text field with 'KAATO' and a magnifying glass icon. To its right, it says 'Australian Taxation Office'.
- Deduction:** A text field with a magnifying glass icon.

The GPAU\_EFT\_CMX Application Engine process extracts the salary data from the Payroll Results table and creates the Cemtex file for transmission to the bank. You can create files for net pay only, recipients only, both net pay and recipients, or for specific deductions.

Field or Control	Description
<b>Payment Type</b>	Select from <i>Group Tax</i> , <i>Net Pay And Recipient</i> , <i>Net Pay Distribution Only</i> , and <i>Recipient Deduction Only</i> . The EFT file that the system creates contains only payments of the type specified.
<b>Entry Description</b>	Included in the header of the EFT file, this indicates the type of data in the file; for example, payroll.
<b>Calendar Group ID</b>	Enter the ID for the calendar group for which the file is created.
<b>Stream Number</b>	You can create the EFT file for only the payees in the stream that you enter here. Stream processing is applicable to only <i>Net Pay Distribution Only</i> , <i>Net Pay</i> , and <i>Recipient</i> .
<b>Process Streams</b>	This check box is automatically selected if you select the <b>Perform Stream Processing</b> option on the Calendar Group ID page. It indicates that you must select a stream number.
<b>Payment Date</b>	This is the date of the actual transfer of the funds. It is written to the EFT file header.
<b>Debit Date</b>	The system extracts recipient payments where their deposit schedule date is equal to the deposit date. If the recipient does not have a deposit schedule, their debit date is equal to the day that the Banking process was run.
<b>Period End Date</b>	This is the end date for the pay period.
<b>Recipient Calculate Option</b>	Select <i>All Recipients</i> , <i>Deduction</i> , or <i>Select Recipient Only</i> . Select a single deduction or a single recipient ID for the second and third options, respectively. For group tax, the recipient is KAATO, the Australian Tax Office. <b>Note:</b> You do not have to select anything here for the Net Pay Distribution Only option.

### Note

If the GPAU\_EFT\_CMX Application Engine process returns No Success due to the error "Credit and Debit Transactions Sharing the same Bank Account : 1," the file is still generated. The system transfers monies to the source account in the instance that an employee does not have a valid account due to effective dates or inactivity. The user can then run the file again or send the file knowing that the monies will be returned to the source bank.

## Generating Recipient Payment Report Files

It is common for organizations to transmit a file to a recipient so that they can update their records. For example, an organization may pay a recipient weekly and at the end of the month deliver a file with all the payment details. Recipients generally specify the information that they

want and the report file layout. After you have created the file layout, link it to the recipient on the Deduction Recipients page.

The PeopleSoft system provides the GPAU\_RCPNT\_FILE sample file layout. The GPAU\_RCPFILE process retrieves the file layout that is specified on the Deduction Recipients page.

This example illustrates a sample recipient file layout

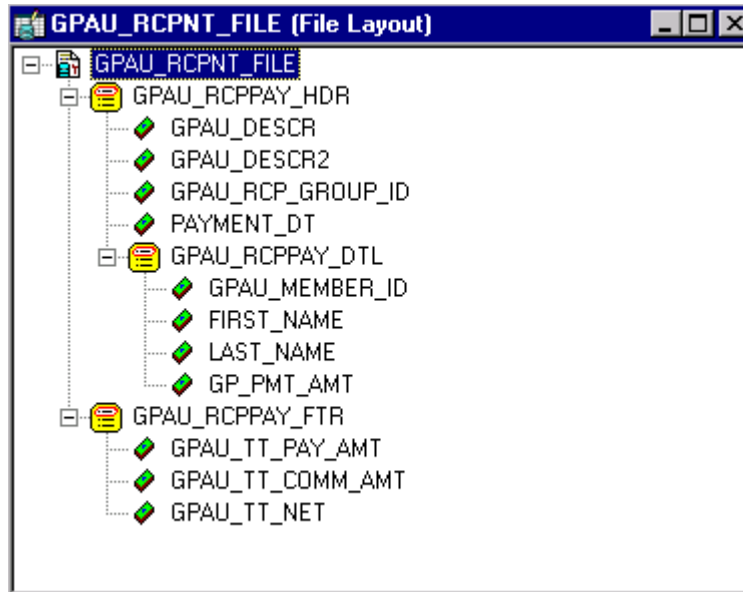

**Note**

This electronic file depends on first running the GPAU\_EFT\_CMX Application Engine process for recipients.

## Page Used to Generate Recipient Payment Report Files

Page Name	Definition Name	Usage
<a href="#">Create Recipient File AUS Page</a>	GPAU_RUNCTL_RCP_FL	Enter the parameters for generating recipient payment files.

## Create Recipient File AUS Page

Use the Create Recipient File AUS page (GPAU\_RUNCTL\_RCP\_FL) to enter the parameters for generating recipient payment files.

Navigation:

**Global Payroll & Absence Mgmt**, and then **Payment Processing**, and then **Create Recipient File AUS**, and then **Create Recipient File AUS**

This example illustrates the fields and controls on the Create Recipient File AUS page. You can find definitions for the fields and controls later on this page.

### Create Recipient File AUS

Run Control ID CRW1 Report Manager Process Monitor Run

\*Debit Date  \*Payment Date

\*Calculate Option Select Recipients Only Deduction

Summary Report

Recipient List		Personalize   Find	First 1 of 1 Last
Recipient ID	Description		
<input type="text"/>		+	-

Field or Control	Description
<b>Debit Date</b>	The system extracts payment data for the deposit date that you enter here.
<b>Payment Date</b>	This is the date, from the EFT file header, that the bank passed the payment to the recipient. It's written to the output report file.
<b>Calculate Option</b>	These are the same options as for the EFT creation process: <i>All Recipients</i> , <i>Deduction</i> , and <i>Select Recipients Only</i> . Select a single deduction or a recipient ID for the second and third options, respectively.

**Note**

The GPAUPY52 recipient file report is a Structure Query Report (SQR) version of the data extracted for the electronic recipient file. When you run the Recipient File Creation Application Engine process from the Process Scheduler Request page, you automatically generate the SQR. If you want the SQR only, you can select its check box and leave the Application Engine check box deselected.

## Reporting Net Payment

The Net Payment report extracts data from the Cemtex Transaction table and the Header table and from the Personal Data and Job records.

Select detail or summary reporting.

### Detail Reporting

This section illustrates sample results of detail reporting. In these results, the detailed information for each employee is followed by two data elements that show the total amount and the total number of payments.

Empl ID	Empl Rcd#	Name	Amount	Payment Method	Bank Name	BSB Number	Account Number	Payment Status
KA0001	0	Taylor, Jane Elizabeth	2976.65	Bank Transfer	ANZ	012002	152545689	Finalized
KA0002	0	Kerr, Elizabeth	4298.16	Bank Transfer	IMB	641800	765908765	Finalized

Field or Control	Description
Total Amount	7274.81
Number of Pays	2

### Summary Reporting

This section illustrates sample results of summary In these results, the report has only two data elements: the total amount and the total number of payments.

Field or Control	Description
Total Amount	7274.81
Number of Pays	2

# 15

## Printing and Viewing Payslips

### Printing Payslips

You print payslips by running the GPAUPY01 SQR process (select **Global Payroll & Absence Mgmt**, and then **Payslips**, and then **Create and Print Payslips AUS**).

The template that you define controls the layout of the printed payslips.

You print payslips by calendar group ID. You can restrict the payslips printed from the pay run associated with the calendar group ID

You can print payslips for:

- An entire calendar group ID.
- Individual payees for the selected calendar group ID.
- Groups of payees in the selected calendar group ID by pay entity, pay group, department, or location.

The run control page has links to the options.

For the Pay Entity option and Pay Group option, you select only pay entities or pay groups, respectively. For the Department option and Location option, you select Set IDs and then departments or location codes, respectively. For the Payee List option, you select only employee IDs.

You can set up to three sort keys from the following options: Department, Employee Name, Location, Not Applicable, Pay Entity, or Pay Group. If you select Not Applicable, the program print the payslips by employee ID.

### Overriding Payslip Delivery Options

The default delivery option for all payslips is the internal or external address that you select when you define the payslip template. You can set an effective-dated override of that delivery option at the payee level. Select **Global Payroll & Absence Mgmt**, and then **Payee Data**, and then **Payslips**, and then **Payslip Delivery Option AUS**.

### Description of Processes in Payslip Job

The Payslip page launches a Job (GPAUPYSL) containing two processes in sequence:

1. The Structured Query Report (SQR) GPAUPY01 prints the payslip report and provides self service related information for ePay if ePay is licensed.
2. The GP\_EPAY Application Engine process uses the payslip report and self service related information provided by the prior processes in this job to create self-service payslips for each payee. If ePay is not licensed, this process will report that ePay has not been licensed and will complete with success.

**Related Topics**

- PeopleSoft ePay: Setting Up View Payslip

## Viewing Payslips Online

If you license PeopleSoft ePay, employees can view an online self-service version of the payslip. To aid in resolving questions that employees have about their payslips, the payroll administrator can view employees' self service payslips in an online view that replicates the employees' view. Both the online view and the printed payslip are based on the layout defined in the payslip template.

**Related Topics**

- [Understanding Payslip Setup](#)  
The Payslip feature enables you to control the content and format of payslips. Because you can override templates at lower levels, you do not have to create multiple templates to cover every payslip scenario.
- PeopleSoft ePay: Viewing Payslips Online

# 16

## Using the General Ledger Interface

### Understanding Payroll Data Processing for GLI or QSP

The Global Payroll results integration point uses PeopleSoft Integration Broker to send payroll results to the Global Payroll Accounting Line Stage Record (GP\_ACC\_LINE\_STG). The data is sent using the General Ledger Transaction Prep application engine process (GP\_GL\_PREP), and uses the Post Global Payroll to General Ledger batch rule (GP\_POST\_GL).

After Global Payroll sends the data, General Ledger can receive the data and incorporate it into its own data.

For more information see PeopleSoft Global Payroll: Understanding the General Ledger Interface.

This diagram represents the processing of payroll data for the GLI or QSP. The two shaded boxes with borders show the added local functionality. Note that the Leave Entitlement option adds data to the GP\_GL\_DATA table for inclusion in the output to either QSP or GLI:

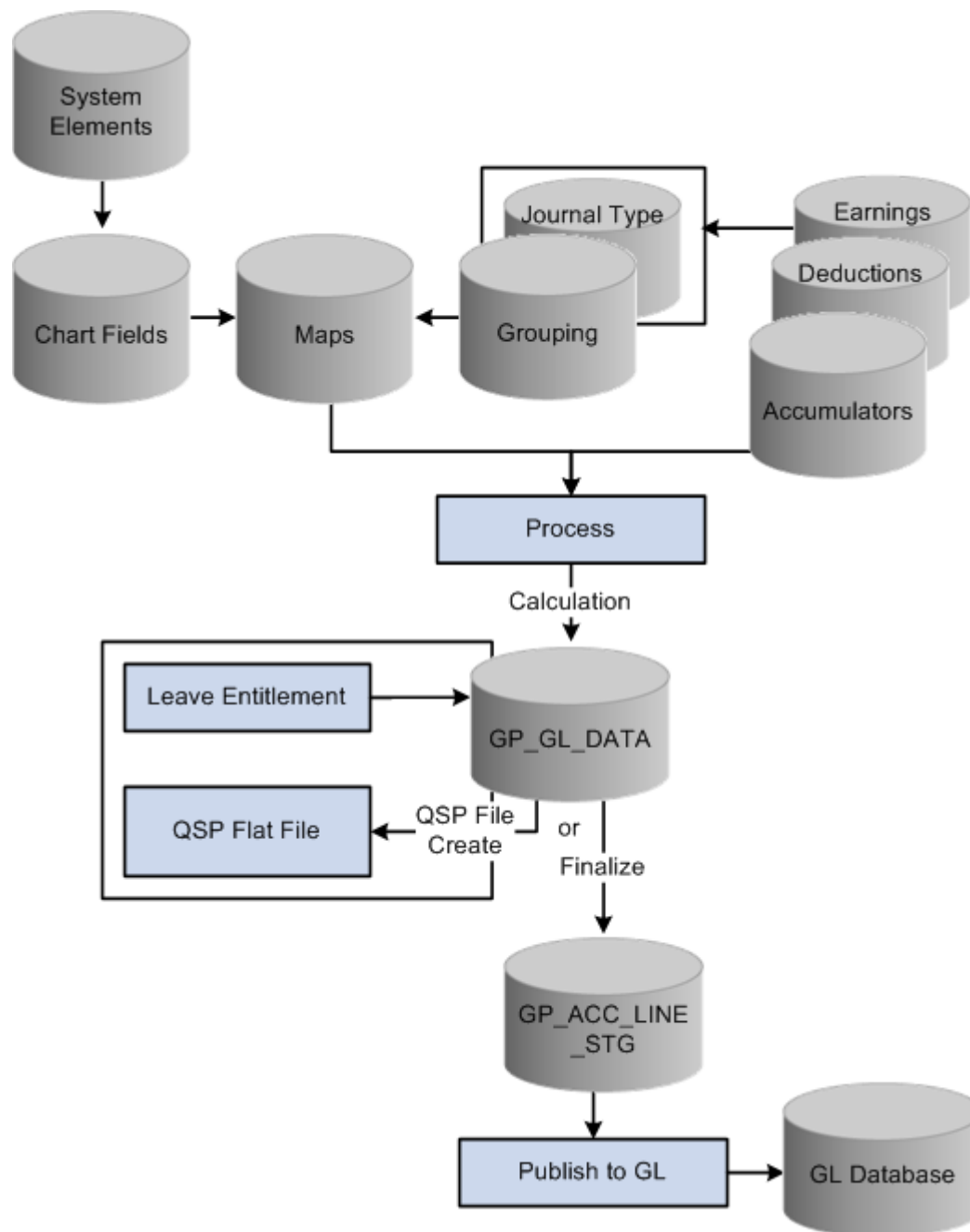

## Linking Journal Types to GL Groupings

To link journal types to GL groupings, use the Journal Type (GPAU\_GLGRP\_JOURNAL) component.

The Office for Government Online (OGO) QSP financials file requires payroll data reported by journal type.

You report payroll data to the GL by journal type by linking a journal type to a GL grouping.

A grouping comprises entry types of earnings, deductions, or segment accumulators. There are five delivered journal types: Accrual, Salary, Employee Entitlement, Statistical, and Terminated EE's (employee's) Entitlement.

Accrual and Statistical journal types are for QSP users only.

### Note

The Leave Entitlements Application Engine process selects data for inclusion into the GPAU\_LEAVE\_LIAB record (from GP\_GL\_DATA) by the flags for journal types Employee Entitlement and Terminated EE's Entitlement. Therefore, any organization needing to resolve leave entitlement calculations within the Leave Entitlement phase of the GL Interface process needs to select a journal type for each GL grouping code associated with GL Liability earnings codes.

The following table shows an example setup. Columns 1 and 2 are from the core Element Groupings page (**Set Up HCM**, and then **Product Related**, and then **Global Payroll & Absence Mgmt**, and then **Integration**, and then **Element Groupings**, and then **Element Groupings**), and column 3 is from the Journal Type AUS page (**Set Up HCM**, and then **Product Related**, and then **Global Payroll & Absence Mgmt**, and then **Integration**, and then **Journal Type AUS**):

Grouping Code	Element	Journal Type
Accrual	GLI Accrual (segment accumulator)	Accrual
Earnings	AUS GROSS (segment accumulator)	Salary
Entitlements	LIAB ANN DAY, LIAB ANN HRS, LIAB LSL WKS (earnings)	Employee Entitlement
Termination	LIAB TAL HRS, LIAB TAL DYS, LIAB TLS WKS (earnings)	Terminated EE's Entitlement

## Page Used to Link Journal Types to GL Groupings

Page Name	Definition Name	Usage
Journal Type Page	GPAU_JOURNAL_TYPE	Attach a journal type to each GL grouping. Select from <i>Accrual, Employee Entitlement, Salary, Statistical, and Terminated EE's Entitlement.</i>

## Understanding Accrued Salary Calculation

If the end date of the last pay period in a month is before the end of the financial month, you can send a percentage of total salary as the accrued costing for the "gap" between the two dates.

Accumulator GLI ACCRUAL has a single member AUS GROSS that contributes the variable GLI VR ACCRUAL PCT. The variable has a value of 0.00. You only want the accumulator's value to be included in the GLI process in the last month, so on the pay calendar for the last period, you need to set the value of the variable as a calendar supporting element override. The value may vary according to the number of days in the gap.

The value sent to QSP is reversed by the financials system the following month and replaced by actual costings.

**Note**

Non-QSP users should give accrued salary journal type Entitlement.

## Understanding Leave Liability Calculation

The amount of leave that an employee is owed needs to be costed as a liability in the GL. For leave liability reporting, we have set up earnings that store the monetary value of each employee's leave entitlement. The earnings are not paid as earnings because they do not contribute to AUS GROSS.

Because the GLI and QSP flat file only requires the difference between the liability for the last pay period and the current pay period, this is what the Application Engine (AE) leave entitlement process calculates and passes to GP\_GL\_DATA.

If an employee has been terminated, the stored value of his or her processed liability has to be reversed out from the GL, because it is no longer a liability.

### Reversing Leave Liability on Termination

Termination liability earnings LIAB TAL HRS, LIAB TAL DYS, LIAB TLS WKS, LIAB TLS FTM and LIAB TLS PTM all have a calculation rule of Amount, where the amount is the corresponding liability earnings:

Earnings	Amount = Earnings (Calc Rule)
LIAB TAL HRS	LIAB ANN HRS (Entitlement balance × Hourly Rate)
LIAB TAL DYS	LIAB ANN DAY (Entitlement balance × Daily Rate)
LIAB TLS WKS	LIAB LSL WKS (Entitlement balance × Days to Weeks formula × Attrition Bracket)
LIAB TLS FTM	LIAB LSLFTM (Entitlement balance × Days to Month formula × Attrition Bracket)
LIAB TLS PTM	LIAB LSLPTM (Entitlement balance × Days to Month formula × Attrition Bracket)

Each earnings element has generation control GLI GC TERM ENT attached, and the generation control's condition is the HR status of Terminated. If an employee is terminated, his or her leave balance liability earnings value becomes the termination liability earnings value for reversal.

## Understanding Leave Liability Reporting

The data that the report process extracts for leave liability reporting can be transferred to the GL through the GLI and included in the QSP financials file.

The reports, the interface, and the QSP file depend on data that is created the same way as any other data that's used for reports, the GLI, or the QSP file generation—by the use of Global Payroll rules.

**Note**

In this section, unless otherwise stated, the term *reported* means printed on a report, available for transfer to GLI, and available for inclusion in the QSP file.

Liability and absence history are calculated and reported to assist in the administration of employee absences and leave. They are used to identify trends in absence and for costing purposes.

**Note**

Absence history and its associated report are not part of the GLI functionality.

See [Global Payroll for Australia Reports: A to Z](#)

Liability is reported for annual leave accrued in hours, annual leave accrued in days, and long service leave accrued in weeks and months. The values are calculated as earnings: LIAB ANN HRS, LIAB ANN DAY, LIAB LSL WKS, LIAB LSLFTM and LIAB LSLPTM. These earnings do not contribute to accumulator AUS GROSS.

When you run the liability report, the parameters include the element category. Earnings LIAB ANN DAY and LIAB ANN HRS are category ANN and LIAB LSL WKS, LIAB LSLFTM and LIAB LSLPTM are category LSL. Entitlement ANN ENTHPH does not currently have a corresponding leave liability earnings created and therefore will not be included in the report. The category value is assigned as a variable LVE VR CATEGORY entered as a supporting element override for each earning.

This section discusses how the following leave liability events are calculated:

- Annual leave liability for hourly accrual.
- Annual leave liability for daily accrual.
- Long service leave liability for weekly accrual.
- Long service leave liability for monthly accrual.
- Leave liability reversal when the cost center changes.

**Note**

The term *pro rata* refers to accrued leave that the payee may or may not be entitled to take. Pro rata becomes entitlement on an anniversary, usually of the payee's hire date. *Entitlement* refers to leave that the payee is entitled to take and that may have once been pro rata leave. This PeopleBook makes this distinction because both entitlement and pro rata are referred to as *entitlement* in the system.

## Annual Leave Liability Calculation for Hourly Accrual

The calculation rule for LIAB ANN HRS is  $\text{Unit} \times \text{Rate}$ , where:

Unit = Accumulator ANN ENTHRS\_BAL

Rate = System element HOURLY RT

## Annual Leave Liability Calculation for Daily Accrual

The calculation rule for LIAB ANN DAY is Unit × Rate, where:

Unit = Formula LVL FM ANN DYS VAL

Rate = System element DAILY RT

The formula LVL FM ANN DYS VAL adds the values of two accumulators, the day's entitlement balance, and the day's pro rata balance, ANN ENTDYS\_BAL and ANN PRODYS\_BAL.

## Long Service Leave Liability Calculation for Weekly Accrual

The calculation rule for earning LIAB LSL WKS is Unit × Rate × Percent, where:

Unit = Formula LVL FM LSL WKS VAL

Rate = Formula AUS FM DAYS TO WKS

Percent = Bracket LVL BR LIAB ATT

Formula LVL FM LSL WKS VAL calculates the units of leave that the payee has by adding the Long Service Leave entitlement balance (accumulator LSL ENTWKF\_BAL) to the Long Service Leave pro rata balance (accumulator LSL PROWKF\_BAL).

Formula AUS FM DAYS TO WKS—the earning's rate—resolves to the payee's pay per week by multiplying his or her FTE (from the Job record) by the variable AUS VR WKLY VAL (set to 5.00; that is, a week is five days) by the employee's daily rate.

Bracket LVL BR LIAB ATT—the earning's percentage—returns a value based upon the payee's years of service and the attrition rates that apply. That is, for example, only 50 percent of payees who have five years of service will stay long enough to qualify for long-service leave.

This table lists the delivered values:

After Number of Years of Service	Estimated Percentage of Payees Who Will Stay to Qualify for LSL
5	50
8	75
10	100

The search key for the bracket is the formula LVL FM DUR IN YRS, which resolves the number of years the payee has served. The formula divides duration LSL DR DYS FR HIRE by the variable LVL VR DAY IN YEAR (set to 365.25) to convert the duration in days to a number of years.

The duration's From date is LVE FM ACCR ST DT, which determines whether to use the payee's hire date or rehire date in calculating the days of service (it uses rehire date if it is later than hire date). The duration's To date is the period end date.

After determining the number of years of service, the bracket can return the value to use as the percentage in the earning's calculation rule.

After the three earnings are calculated their values are available for reporting, passing to GL by the GLI, or including in the QSP file.

## Long Service Leave Liability Calculation for Monthly Accrual

The calculation rules for earnings LIAB LSLFTM and LIAB LSLPTM, the monthly full and part accruals, are  $\text{Unit} \times \text{Rate} \times \text{Percent}$ , where:

Unit = Formula LVL FM LSL MTHFTV and LVL FM LSL MTHPTV, respectively

Rate = Formula AUS FM DAYS TO MTH

Percent = Bracket LVL BR LIAB ATT

Formula LVL FM LSL MTHFTV calculates the units of leave that the payee has by adding the Long Service Leave entitlement balance (accumulator PSH LSENTFT\_BAL) to the Long Service Leave pro rata balance (accumulator PSH LSLPROFT\_BAL) for the Full Time leave.

Formula LVL FM LSL MTHFTV and LVL FM LSL MTHPTV calculates the units of leave that the payee has by adding the Long Service Leave entitlement balance (accumulator PSH LSENTPT\_BAL) to the Long Service Leave pro rata balance (accumulator PSH LSLPROPT\_BAL) for the Part Time leave.

Formula AUS FM DAYS TO MTH—the earning's rate—resolves to the payee's pay per month by multiplying his or her FTE (from the Job record) by the variable AUS VR MTHLY VAL (set to 30.00; that is, a month is thirty days) by the employee's daily rate.

The attrition rates bracket is the same as that used in the LSL weekly accrual.

### Related Topics

- [Long Service Leave Liability Calculation for Weekly Accrual](#)  
The calculation rule for earning LIAB LSL WKS is  $\text{Unit} \times \text{Rate} \times \text{Percent}$ , where:
- [Global Payroll for Australia Reports: A to Z](#)  
These tables list the Global Payroll for Australia reports sorted by report ID. For more information about running these reports refer to:

## Leave Liability Reversal When the Cost Centre Changes

The Leave Entitlements process determines if there is a change of ChartField for each employee—where ChartFields represent cost centres such as department and pay group. When the program detects a change, it reverses the liability from the centre storing the processed liability and sends the full amount of the new (unprocessed) liability (not the difference) to the new cost centre.

## Calculating State Payroll Tax Liability

To set up calculation of state payroll tax liability, use the Sal Pkg Payroll Tax Rates AUS (GPAU\_PYTX\_RT\_TBL) component.

Payroll tax liability is calculated and becomes earning PYRL TX PROV for mapping to the GL, as for any other earnings. Array GLI AR PYTX RT, with its processing formula GLI FM CHK STATE, determines an employee's state and payroll tax rate. The rate is multiplied by the accumulator GLI SPT PROVISION, the members of which are the earnings and deductions liable for payroll tax.

**Note**

You need to ensure that all earnings and deductions liable for state payroll tax are in the GLI SPT PROVISION accumulator. This is only a provision for GL reporting, not actual State Payroll Tax amounts.

This topic lists the page used to calculate state payroll tax liability.

## Page Used to Calculate State Payroll Tax Liability

Page Name	Definition Name	Usage
State Payroll Tax Page	PKG_PYTX_RT_TBL	Maintain the tax rates state by state. The GLI needs the percentages to calculate the state payroll tax (SPT) provision.

### Related Topics

- [PeopleSoft Human Resources Administer Salary Packaging: Setting Up and Viewing Salary Packaging Tax Options](#)
- [Identifying Data for State Payroll Tax Reporting](#)  
Before you begin configuring Global Payroll to report payroll tax, you need to identify the earnings, deductions, benefits, and expenses that are subject to payroll tax. To do this, check with the state revenue office of each state in which the organization pays employees. After you have gathered this information, run the payroll routinely and process payroll tax.
- [Understanding State Payroll Tax Reporting](#)  
The State Payroll Tax report provides detailed information about the earnings, benefits, deductions, and expenses that are identified as payroll taxable or payroll tax exempt. Details are also provided for termination payments that are payroll tax exempt.
- [Running the State Payroll Tax Report](#)  
The GPAU\_SPT\_RPT Application Engine process extracts data for state payroll tax reporting, and that data is formatted as a report by the GPAUT01 Structured Query Report.

## Running the GLI or QSP Process

This topic provides an overview of GLI and QSP processes and discusses how to run the General Ledger process.

## Pages Used to Run the GLI or QSP Process

Page Name	Definition Name	Usage
<a href="#">Send Costs to GL AUS Page</a>	GPAU_GL_PREPARE	Initiate the processes for calculation of GL data, leave entitlement, QSP flat file creation, finalization of the GLI, and statistical data updating.

Page Name	Definition Name	Usage
Ledger Transaction Page	GPAU_GL_INQUIRY	View GL costing data.

## Understanding GLI and QSP Processes

The Calculate phase of GLI processing populates the GP\_GL\_DATA table. The Leave Entitlement process uses the Leave Entitlement Application Engine process (GPAU\_LVE\_ENT) to compare previous entitlement liability to current entitlement liability and load the difference into GP\_GL\_DATA. The GLI/QSP Application Engine process (GPAU\_QSP\_GLI) manages the payroll data and generates the QSP flat file.

You can also run The GL Mapping Application Engine process (GPAUS\_GL\_MAP) that updates ChartFields in GP\_GL\_DATA. The process selects and updates the necessary GP\_GL\_DATA records with specified ChartField overrides. When you run the GL Interface Finalize process, the data is summarized by using your selected (remapped) ChartFields for correct account mapping.

### Note

You need to have already finalized your payroll to obtain up-to-date entitlement balances—upon which the liability calculation is based—for annual leave and long service leave.

After you have updated the GP\_GL\_DATA table, you can complete the standard core GLI process by running the Finalize process or you can generate the QSP file by running the QSP File Create process.

## Send Costs to GL AUS Page

Use the Send Costs to GL AUS page (GPAU\_GL\_PREPARE) to initiate the processes for calculation of GL data, leave entitlement, QSP flat file creation, finalization of the GLI, and statistical data updating.

Navigation:

**Global Payroll & Absence Mgmt**, and then **Time and Labor / GL Costs**, and then **Send Costs to GL AUS**, and then **Send Costs to GL AUS**

This example illustrates the fields and controls on the Send Costs to GL AUS page. You can find definitions for the fields and controls later on this page.

### Send Costs to GL AUS

Run Control ID 1   Report Manager   Process Monitor   Run

<b>Payroll Run</b> *Calendar Group <input type="text"/> Stream Number <input type="text"/> <input type="checkbox"/> Process Streams *Posting Date 01/01/2013 <input type="text"/>	<b>Processing Phases and Options</b> <input type="checkbox"/> Calculate <input type="checkbox"/> Leave Entitlement <input type="checkbox"/> Chart Field Remap <input type="checkbox"/> QSP File Create <input type="checkbox"/> Finalize <input type="checkbox"/> Update Statistics Journal Name <input type="text"/>
--	--

Processing Phases				Personalize   Find   <input type="text"/>   <input type="text"/>   <input type="text"/>   First 1 of 1 Last
Stream	Calculate	Chart Remap	Leave Ent	
1	<input type="checkbox"/>	<input type="checkbox"/>	<input type="checkbox"/>	

Calendar List			Personalize   Find   <input type="text"/>   <input type="text"/>   <input type="text"/>   First 1 of 1 Last
Pay Group	Calendar ID	Payment Date	
1			

**Note**

The differences between this page and the page that you access by selecting **Compensate Employees**, and then **Manage Payroll Process**, and then **Process** are the three additional processing phases and options: Chart Field Remap, Leave Entitlement, and QSP File Create.

### Processing Phases and Options

Field or Control	Description
<b>Chart Field Remap</b>	Select to enable the ChartField Remap Application Engine process (GPAUS_GL_MAP) when running the General Ledger process. This run control page enables you to run an Application Engine process that updates ChartFields in GP_GL_DATA. The program selects and updates the necessary GP_GL_DATA records with specified ChartField overrides. When you run the GL Interface Finalize process, the data is summarized by using your selected (remapped) ChartFields for correct account mapping.

### Running the ChartField Remapping Process

The ChartField remapping process:

- Uses specified ChartField overrides and updates the GP\_GL\_DATA records.
- Enables the GL Interface Finalize process to correctly summarize transactions by using your selected combination of ChartFields, grouping codes, and account values.

You run the new Application Engine process as part of the standard General Ledger Interface process in the following sequence:

1. Ensure that the GL Calculate phase is complete.

2. Run the new Application Engine process to perform department remapping.  
You run the remap before the leave entitlement process. If you alter the remap, you must always rerun the calculate process. You can't rerun the remap process until you have run the calculation process.
3. Ensure that the GL Leave Entitlement phase is complete.
4. Run the GL Finalize process.

**Note**

This process runs as a separate process and is not integrated into existing Application Engines. In this way, it does not affect the existing GLI.

The **Journal Name** field is used when you select QSP File Create. The journal name is a user-defined and entered value, which is included in the QSP file header.

The following table shows which processes apply:

Process or Phase	PeopleSoft GL	QSP GL
Calculate	Y (yes)	Y
Leave Entitlement	Y	Y
QSP File Create	N (no)	Y
Finalize	Y	N
Update Statistics	Y	Y

**Note**

The QSP File Create phase includes some of the GLI Finalize phase processing so that you do not have to finalize after creating the QSP flat file.

## Remapping ChartFields After Initial Calculation

To remap ChartFields, use the GL Chartfield Remapping AUS (GPAU\_GL\_MAP) component.

Global Payroll for Australia enables you to define ChartField remapping data used during the General Ledger (GL) interface process and post payroll costs to differing levels of ChartFields based on GL groupings codes or accounts. You set up GL ChartField parameters that enable you to remap default ChartFields after you run the initial Calculate process. For example, you might require that a higher level of ChartFields be attached to each of your account codes. Instead of using multiple departments for each account code, you may require one global ChartField level, which covers all departments.

This topic discusses how to remap ChartFields.

## Page Used to Remap ChartFields After Initial Calculation

Page Name	Definition Name	Usage
<a href="#">GL Chartfield Remapping AUS Page</a>	GPAU_GL_MAP	Set up GL ChartField parameters that enable you to remap ChartFields after you run the initial Calculate process. You can configure and maintain GL remapping data. Enables you to set up different levels of ChartFields based on GL groupings codes or accounts.

## GL Chartfield Remapping AUS Page

Use the GL Chartfield Remapping AUS page (GPAU\_GL\_MAP) to set up GL ChartField parameters that enable you to remap ChartFields after you run the initial Calculate process.

You can configure and maintain GL remapping data. Enables you to set up different levels of ChartFields based on GL groupings codes or accounts.

Navigation:

**Set Up HCM**, and then **Product Related**, and then **Global Payroll & Absence Mgmt**, and then **Integration**, and then **GL Chartfield Remapping AUS**, and then **GL Chartfield Remapping AUS**

This example illustrates the fields and controls on the GL Chartfield Remapping AUS page. You can find definitions for the fields and controls later on this page.

**GL Chartfield Remapping AUS**

Pay Entity GAAUSBI Australian Business Institute2  
Business Unit AUS01 Australian Business Unit  
General Ledger Unit AUS01

Chartfields Find | View All First 1 of 1 Last  
\*Effective Date 01/01/2004

Chartfields to be passed to GL  
 DEPTID

Chartfield Transformations Personalize | Find | View All | First 1-8 of 11 Last

Seq Nbr	Account	Grouping Code	DEPTID
1	207000	ACCRUAL-LIAB	
2	201600	DEDN-NONTAX LBY	
3	201600	DEDNS-GARN	
4	201600	DEDNS-POST TAX	
5	201600	DEDNS-PRE TAX	
6	212000	ENT - AL LIAB	
7	201500	NET PAY	
8	202000	SP TAX - LIAB	

## Chartfields

ChartFields represent attributes of a payee, such as department, company, or employee ID. When you send a payee's earnings, deductions, or accumulator amounts to General Ledger, you can also transmit the values that are associated with your specific combination of ChartFields for the payee.

Field or Control	Description
<b>Chartfields to be passed to GL</b>	A field appears for each ChartField that you set up on the Mapping page in Global Payroll. Use the specific ChartFields check boxes to prevent the system from sending particular ChartFields to the GL. During mapping, ChartFields can be used to cost to different account codes. You can then elect not to send the ChartFields to the GL and only send the values to the accounts. When integrating Global Payroll with General Ledger, you can remap ChartField values to a business unit's GL account numbers. To enter the new, remapped ChartField value, use the Transformed Values tab.

## Chartfield Transformations

The default ChartFields values appear in the fields on the ChartFields tab. To remap the default settings, select the new values on the Transformed Values tab.

## Chartfields and Transformed Values

Field or Control	Description
<b>Account</b>	Displays the GL account number to which your ChartFields and grouping codes will map.
<b>Grouping Code</b>	Select the code to map to the GL account. This is the grouping code for the elements that are included in the GL transfer. A grouping comprises entry types of earnings, deductions, or segment accumulators. Elements must be in groups before they can be processed by General Ledger. Instead of entering earnings individually, you bundle them into one accumulator and create a grouping code for that accumulator.

# 17

## Defining Absence Rules

### Understanding Absence Rules

Managing absences and periods of leave in Australia is complex, because business practices and state legislation vary on issues such as the rate and frequency at which leave accrues and whether it becomes immediate entitlement or starts as pro rata leave.

#### Note

An absence entitlement can be an actual entitlement that is wholly or partially taken, it can be pro rata which is wholly or partially taken (while still pro rata), or it can be taken on its transfer to entitlement on a specified anniversary. In these topics, the term *entitlement* refers to entitlements only, and the term *pro rata* refers to pro rata only. The term *absence entitlement* refers to both.

The PeopleSoft system provides 17 absence entitlement elements and 14 absence take elements. These elements demonstrate how Global Payroll can process typical leave requirements in Australia. They cover annual leave and long service leave—including OGO, sick leave, and other types of leave such as maternity leave, jury service, and workers' compensation.

### Deducting Leave Hours from Regular Hours

When leave is paid to employees who work regular standard hours, the hours paid as leave must be deducted from the regular standard hours.

To achieve this, the leave earnings appear in a section in the process list that is resolved before regular pay. The same earnings contribute to the ERN AC REDUCE HRS accumulator. The unit in the calculation rule for the REGPAY STDHR earnings element is formula ERN FM REGSTD UNIT, and the ERN AC REDUCE HRS accumulator subtracts from the regular hours calculation within the formula.

### Using Delivered Absence Primary Elements

Primary absence elements are absence entitlements—entitlement or pro rata—and absence takes. In the two tables following we cross reference entitlements to takes and takes to entitlements in the description column.

### Delivered Absence Entitlements

The following table lists the delivered absence entitlements in Global Payroll for Australia:

Name	Description / Corresponding Take
<i>Annual Leave</i>	
ANN ENTHRS	Annual Leave Hours Entitlement / ANN TKEHRS
ANN ENTDYS	Annual Leave Days Entitlement / ANN TKEDYS
ANN PRODYS	Annual Leave Days Pro Rata / ANN TKEDYS
ANN ENTHPH	Annual Leave Hours Per Hour Entitlement / ANN TKEHPH
<i>Long Service Leave</i>	
LSL ENTWKF	LSL Federal Entitlement Weeks / LSL TKEWKF
LSL PROWKF	LSL Federal Pro Rata Weeks / LSL TKEWKF
LSL ENTWKO	LSL Other (State) Entitlement Weeks / LSL TKEWKO
LSL PROWKO	LSL Other (State) Pro Rata Weeks / LSL TKEWKO
<i>Long Service Leave (OGO)</i>	
PSH LSENTFT	LSL Entitlement Full Time incl PSH / PSH LSLTKEFT
PSH LSENTPT	LSL Entitlement Part Time incl PSH / PSH LSLTKEFT
PSH LSLPROFT	LSL Pro rata Full Time incl PSH / not used
PSH LSLPROPT	LSL Pro rata Part Time incl PSH / not used
<i>Sick Leave</i>	
SCK ENTDYS V	Sick Leave Variable Days Entitlement / SCK TKEDYS V
SCK ENTDYS F	Sick Leave Fixed Days Entitlement / SCK TKEDYS F
SCK ENTHRS	Sick Leave Hours Entitlement / SCK TKEHRS
SCK PROHRS	Sick Leave Hours Pro Rata / SCK TKEHRS
<i>Other</i>	
GENERIC ENT	Generic Per Absence Entitlement / Various Takes

## Delivered Absence Takes

The following is a list of the delivered absence takes in Global Payroll for Australia.

Name	Description / Take Uses
<i>Annual Leave</i>	
ANN TKEHRS	Annual Leave Take Hours Entitlement / ANN ENTHRS
ANN TKEDYS	Annual Leave Take Days Entitlement / ANN ENTDYS, ANN PRODYS
ANN TKEHPH	Annual Leave Take HoursPerHour Entitlement / ANN ENTHPH

Name	Description / Take Uses
<i>Long Service Leave</i>	
LSL TKEWKF	LSL Take Federal Entitlement / LSL ENTWKF, LSL PROWKF
LSL TKEWKO	LSL Take Other (State) Entitlement / LSL ENTWKO, LSL PROWKO
<i>Long Service Leave (OGO)</i>	
PSH LSLTKEFT	LSL FullTime Months Take / PSH LSENTFT
PSH LSLTKEPT	LSL PartTime Months Take / PSH LSENTPT
<i>Sick Leave</i>	
SCK TKEDYS V	Sick Lve Take Variable Days / SCK ENTDYS V
SCKTKEDYS F	Sick Leave Take Fixed Days / SCK ENTDYS F
SCK TKEHRS	Sick Leave Take Hours Entitlement / SCK ENTHRS, SCK PROHRS
<i>Others</i>	
WCOMPKE	Workers' Compensation Take / GENERIC ENT
LWOP TKE	Leave Without Pay Take / GENERIC ENT
MATERNITY TKE	Maternity Leave Take / GENERIC ENT
JURY SERVICE TKE	Jury Service Leave Take / GENERIC ENT

## Accruing Entitlement and Pro Rata Leave (Non-OGO)

Annual leave, long service leave, and sick leave are accrued by hours, days, weeks or months, and as either entitlement only or pro rata and entitlement.

### Accruing and Taking Annual Leave

This section discusses each of the annual leave entitlements and their respective take elements.

#### Hours Per Year—Entitlement Only

This is absence entitlement ANN ENTHRS. It has to determine the accrual rate per frequency and is based on a standard annual accrual of 152 hours and 38 standard weekly work hours (38 × 4 weeks leave per year = 152).

The absence element's entitlement value on the calculation page is formula ANN FM ENTHPY. This formula prorates the annual hours accrual for each employee because their standard hours (on JOB) may not be your organization's standard weekly work hours set in variable LVE VR ENT STD HRS on the Supporting Elements Override page of the absence entitlement. The standard annual entitlement, 152, is set in variable ANN VR ENTHRS.

(Standard weekly hours for employee ÷ Entitlement standard weekly hours) × Annual entitlement = ANN FM ENTHPY

$$35 / 38 \times 152 = 139.999999$$

**Note**

The rounding rules handle the fractions. Standard weekly hours for the employee are calculated by formula LVE FM WK STD HRS, which annualizes and deannualizes the employee's standard hours because the work period (in the Job record) may not be weekly, and the proration of the annual accrual is based on weekly hours.

The annualized accrual is deannualized by the absence calendar frequency when the calendar is run. The deannualized accrual adds to the absence entitlement's `_ENT` and `_BAL` accumulators.

Accumulators are stored by EMPL ID/EMPL RCD and begin at hire date or rehire in the first instance. When a new accumulator instance is automatically created for a new year to date (YTD) period, the previous value of the `_BAL` accumulator is rounded and rolled over into the new YTD accumulator instance. The other accumulators are reset to 0.

The related absence take, ANN TKEHRS, decrements the absence units from the `_BAL` accumulator and stores them in the `_TKE` accumulator.

The units (hours) to decrement are resolved by the take's hours-based day formula, LVE FM HRS ABS PH which:

1. Determines if the day is a public holiday.  
If it is, the system does nothing further because there are no entitlement hours used or annual leave paid for that day.
2. Checks for scheduled and partial hours and returns partial hours if there are any.
3. If there are no partial hours, it checks for a decimal value in the **User Defined 1** field on the Absence Event Input Detail page.  
If there is a value (any value) it halves the scheduled hours.
4. If it isn't a public holiday, there are no partial hours and no halving, and there are scheduled hours, the formula returns the scheduled hours.
5. The units returned become the paid units (DAY COUNT PD) and unpaid units (DAY COUNT UNP) depending on available absence entitlement.

These units are mapped to the appropriate earnings elements (ANN and LWOP, respectively), which the system processes as positive input when the payroll calendar is run. The value of DAY COUNT PD is also mapped to the LVLD (leave loading) earnings element if a leave loading is required.

**Note**

Any value in the decimal field will halve the hours taken. You can use this to take twice as long a leave period at half hours per day, which is effectively half pay per day.

The day formula includes a check to see if a forecasted leave duration (in hours) is overridden in the **User Defined 3** field on the take's Calculation page. If it is, that duration represents the whole leave period so the system stops using the day count formula to determine the leave duration in hours.

### Days Per Year—Pro Rata and Entitlement

This scenario requires two absence entitlements, ANN PRODYS and ANN ENTDYS, which this discussion refers to as *entitlement* and *pro rata*, respectively. The pro rata day entitlement, ANN PRODYS, determines the accrual rate per frequency. Its entitlement value on the calculation page is numeric 20 and the specified frequency is A (annual).

The entitlement value, 20, is deannualized according to the calendar period frequency for each employee.

**Note**

When an employee works less than five days per week and therefore accrues less than 20 days per year, you can enter an employee level override on the Entitlement/Take Assignment page to change the entitlement unit value; for example, from 20 to 16 for an employee working a four-day week.

When you run the absence calendar, the deannualized value is accrued to the pro rata year-to-date \_ENT and \_BAL accumulators. The year in the year-to-date is set when the accumulator's begin option is *Specify Date*, and the begin month and begin day are generic variables LVE VR HIRE MONTH and LVE VR HIRE DAY, which hold the employee's hire month and day, respectively. The accumulators are stored by EMPL ID/EMPL RCD.

When the system automatically creates new instances of the accumulators at the hire date anniversary, the previous values of the entitlement \_ENT and \_BAL accumulators are rolled over into their new instances and the previous values of the pro rata \_ENT and \_BAL accumulators are rounded and rolled over into the new instances of the entitlement \_ENT and \_BAL accumulators.

This diagram shows pro rata balances transferring to new instances of entitlement balances

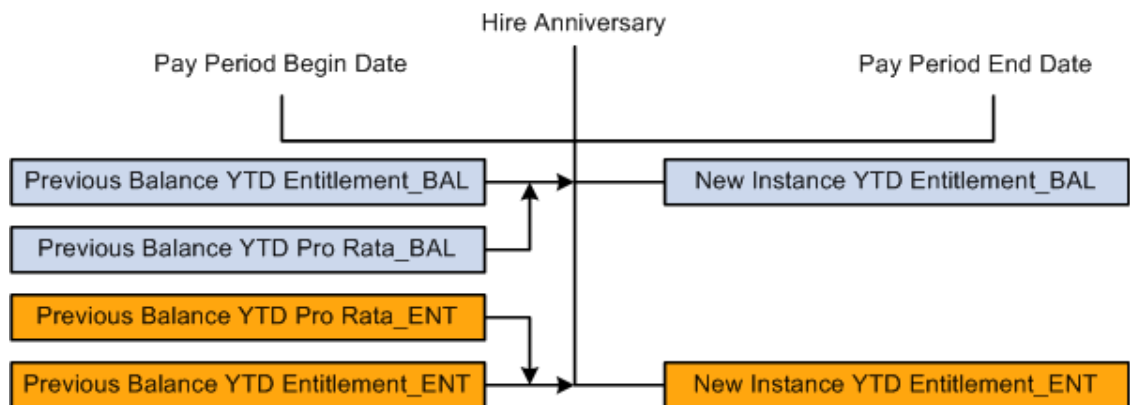

The current calendar period is then split into pre-hire anniversary and post-hire anniversary periods, using generic date element LVE DT HIRE ANN DT. The pre-hire anniversary days are then used in formula ANN FM P2EDYS EMBR to work out the proportion of the accrual that belongs to the pre-hire anniversary period. This value is then sent to variable ANN VR PP2EDYS MBR, which adds to the entitlement \_BAL and \_ENT accumulators.

This diagram shows accrual for the days before hire anniversary becoming entitlement.

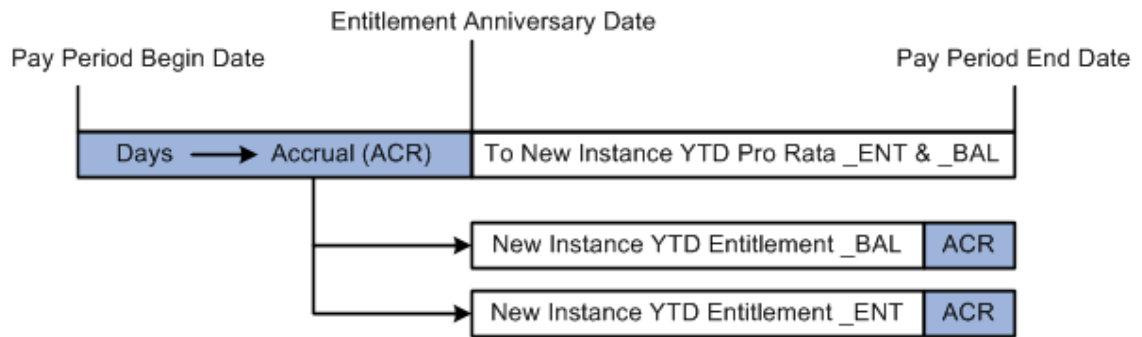

The pre-hire anniversary accrual variable, ANN VR PP2EDYS MBR, also subtracts from the pro rata \_ENT and \_BAL accumulators. This reduces the pro rata \_ENT and \_BAL balances by the amount of the accrual that was accrued in the previous accumulator period.

The absence take, ANN TKEDYS, related to both the pro rata and entitlement absence elements (indicating that pro rata days can be used despite not having become entitlement yet) firsts looks to the entitlement balance to decrement absence units before looking to the pro rata balance to further decrement absence units (where the entitlement units are depleted).

The units (days) to decrement is resolved by the take's Day Formula, LVE FM DYS ABS PH which:

1. Determines if the day is a public holiday.

If it is, it does nothing further because no entitlement hours are used and no annual leave is paid for that day.

2. Checks for scheduled and partial hours; if there are partial hours, the system returns the fraction of the day the hour represents and then rounds them.

Partial hours ÷ Scheduled hours = Fraction of day absent

$$2 \div 8 = 0.25$$

The formula includes variable LVE VR DYS ABSENT, which holds the cumulative value of the results of the day formula as it resolves for each day in the leave period. It starts as 0. In this example, its value after the resolution for day 1 would be  $0 + 0.25 = 0.25$ .

3. If there are no partial hours, it checks for a decimal value in the **User Defined 1** field on the Absence Event Input Detail page.

If there is *any* value, it adds 0.5 to LVE VR DYS ABSENT. Assuming this is the case, in this example Day 1 + Day 2 = 0.75.

4. If it isn't public holiday, there are no partial hours or halving, but there are scheduled hours, then the formula adds 1 to LVE VR DYS ABSENT.

The units returned become the paid units (DAY COUNT PD) and unpaid units (DAY COUNT UNP) depending on available absence entitlement days and pro rata days.

The positive input for this absence take is earnings ANN and LWOP. The units for these earnings are formulas LVE FM DY DCP HRS and LVE FM DY DCUP HRS, respectively. The formulas multiply the DAY COUNT PD and DAY COUNT UNP by the scheduled hours, so the system can pay the leave in hours.

**Note**

Any value in the decimal field halves the hours taken. You can use this to take twice as long a leave period at half hours per day which is effectively half pay per day.

Anything but a partial day returns either 0.5 or 1, because a day can only be a partial hours fraction, a half day or a full day.

**Hours Per Hour—Entitlement Only**

This leave entitlement is ANN ENTHPH, and there is no pro rata leave. Leave accrues as a fraction of an hour per hour worked. The hourly accrual rate (the fraction) is derived from  $4 \times 38$  hour weeks, or 152 hours per year.

The hour fraction, stored in variable ANN VR ENTHPH, is set to 0.076712. That figure comes from:

$$(152 \div 52.14308 \text{ (the weekly annualization factor)}) \div 38 = 0.076712$$

Accumulator ANN AC ENTHPH REG stores the units of hourly pay for the calendar period, and ANN ENTHPH entitlement's formula ANN FM ENTHPH multiplies the accumulated hours by the variable when the absence calendar is run and populates its \_ENT and \_BAL accumulators.

**Note**

The formula also checks to see if the employee hasn't been terminated. If he has, the formula returns ANN VR ENTHPH  $\times$  TER VR FINAL HRS.

The absence take for this leave accrual is ANN TKEHPH, and its day formula is LVE FM HRS ABS PH—the same day formula that take ANN TKEHRS uses.

**Note**

If you pay more than 38 hours per week, this entitlement accrues more than the annual maximum of 152 hours (unless there are balancing reductions in other weeks).

## Accruing and Taking Long Service Leave

This section discusses each of the long service leave (LSL) entitlements and their respective absence takes. There are two absence entitlements and two pro rata entitlements—one of each for federal long service leave and *other* (or state-based) long service leave. They are LSL ENTWKF and LSL PROWKF for federal and LSL ENTWKO and LSL PROWKO for other (or state).

**Long Service Leave Pro Rata and Entitlement—Federal**

This scenario is based on 13 weeks LSL after 15 years of service. Pro rata balances transfer to entitlement on the completion of the first 15 years service and then annually.

The pro rata element LSL PROWKF accumulates the leave using variable LSL VR ENTWKF, which has a value of 0.866667 as the maximum yearly accrual value in weeks

15 years × 0.866667 weeks = 13 weeks (rounded)

When the absence calendar is run, the accrual value is deannualized depending on the calendar period frequency of the employee and the value passed to the LSL pro rata year-to-date \_BAL and \_ENT accumulators. Both accumulators have an initialize rule that transfers their balances to new instances. The initialize rule formulas are LSL FM PROWKF BMBR for \_BAL and LSL FM PROWKF EMBR for \_ENT. The formulas resolve to the value of system element PREV VALUE ACCM and add to the new instances.

The entitlement element LSL ENTWKF handles the transfer of the pro rata balances to entitlement using its formula LSL FM MVE P2EWKF, which:

1. Checks if the duration LSL DR DYS FR HIRE (days from hire) returns days more than or equal to variable LSL VR 15 Y IN D (15 years expressed in days, or 5, 478) and that the LSL ENTWKF \_ENT accumulator is 0 (which indicates that nothing has been transferred to this life-to-date accumulator).
2. If duration does return more than 5,478 days and the entitlement \_ENT balance is 0, the formula passes the value of 15 years of accrual to the entitlement and decrements the pro rata.

By the same method, the formula also transfers the pro rata \_ADJ and \_TKE balances to their respective entitlement accumulators.

3. If the conditions in step 2 are not met, the formula determines if the duration returns more than 5,478 days, and it verifies that the pro rata \_ENT balance is more than or equal to 0.86667.

This condition indicates that another year's worth of pro rata leave has accrued. Because pro rata becomes entitlement annually after the initial 15 years transfer, the formula transfers the four pro rata balances to their respective entitlement balances by the same method.

#### Note

In step 3, the formula checks the balance of the pro rata \_ENT accumulator, because if it checked only for a non-0 balance in the entitlement accumulator after the initial 15 years transfer, subsequent transfers would occur every time the absence calendar runs instead of waiting for a year's worth of accrual in the pro rata accumulator.

The absence take, LSL TKEWKF, related to both the pro rata and entitlement absence elements (indicating that pro rata days can be used despite not having become entitlement yet), firsts looks to the entitlement balance to decrement absence units before looking to the pro rata balance to further decrement absence units (where the entitlement units are depleted).

The units (weeks) to decrement are resolved by the take's day formula, LVE FM WKF ABS NPH. The formula checks the scheduled hours or partial hours for each day and converts them to fractions of a week because the units by which to decrement the leave balances are weeks. The formula does this by dividing all hours returned by the day formula by LVE FM WK STD HRS. The day formula LVE FM WKF ABS NPH:

1. Checks for scheduled and partial hours, and if there are partial hours, the system returns the fraction of the week the hours represent then rounds them.

Partial hours ÷ Standard weekly hours = Fraction of week absent

$$6 \div 40 = 0.15$$

The formula includes variable LVE VR WKS ABSENT, which holds the cumulative value of the results of the day formula as it resolves for each day in the leave period. It starts as 0. In this example, its value after the resolution for day 1 would be  $0 + 0.15 = 0.15$ .

2. If there are no partial hours but there are scheduled hours, it converts the hours to a fraction of a week (0.2 for an eight-hour day) and then checks for a decimal value in the **User Defined 1** field on the Absence Event Input Detail page.

If there is *any* value, it halves the value of the fraction of a week and adds the value to LVE VR WKS ABSENT. Assuming this to be the case after processing the second day, LVE VR WKS ABSENT is:

$$\text{Day 1} + \text{Day 2} = 0.15 + (0.2 / 2) = 0.25 \text{ weeks} = \text{LVE VR WKS ABSENT}$$

3. If there are no partial hours but there are scheduled hours and there is no halving, the formula adds the scheduled hours—already converted to a fraction of a week—to LVE VR WKS ABSENT.

$$\text{Day 1} + \text{Day 2} + \text{Day 3} = 0.15 + (0.2 / 2) + 0.2 = 0.45 \text{ weeks} = \text{LVE VR WKS ABSENT}$$

The units returned become the paid units (DAY COUNT PD) and unpaid units (DAY COUNT UNP) depending on available absence entitlement weeks and pro rata weeks. The positive input for this absence take are earnings LSL and LWOP. The units for these earnings are formulas LVE FM WK DCP HRS and LVE FM WK DCUP HRS, respectively. The formulas multiply the DAY COUNT PD and DAY COUNT UNP (both in weeks) by the standard weekly hours so the system can pay the leave in hours.

#### **Note**

Any value in the decimal field halves the fraction of a week. You can use this to take twice as long a leave period at  $(\text{weeks per day}) \div 2$ , which is effectively half pay per week.

### **Long Service Leave Pro Rata and Entitlement—Other (State)**

This scenario is based on 13 weeks LSL after either 10 or 15 years of service, depending on the state. Pro rata balances transfer to entitlement on the completion of the first 10 or 15 years service and then annually.

For the Australian Capital Territory, New South Wales, Queensland, Victoria, and Western Australia the accrual is 0.866667 weeks per year where:

$$15 \text{ years} \times 0.866667 \text{ weeks} = 13 \text{ weeks (rounded)}$$

For South Australia and Northern Territory the accrual is 1.3 weeks per year where:

$$10 \text{ years} \times 1.3 \text{ weeks} = 13 \text{ weeks}$$

The accrual is granted for whole months only so the formula grants the accrual if the hire day value is in the calendar period (and the hire date is not in the period).

This diagram shows when the accrual is and is not granted. The letter *N* indicates *not granted* (because the hire day is not in the period). You need to distinguish between hire *date* and hire *day*.

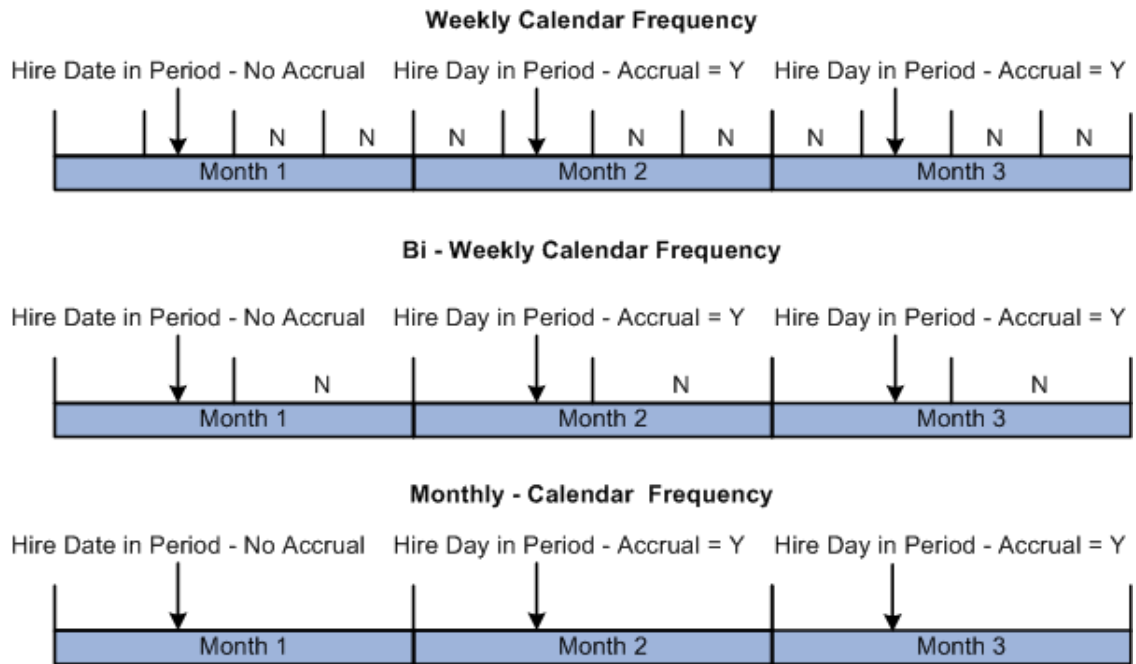

The pro rata element LSL PROWKO accumulates the leave using entitlement formula LSL FM ACCR FMTH which:

1. Determines if the employee's hire date is in the calendar period; if it is, it stops.
2. If the hire date is not in the period but the hire day is, a full month's accrual is due so the formula retrieves the employee's state from array AUS AR EE JOBJR.
3. Checks bracket LSL BR ACCRUAL, and using the employee's state, retrieves either 0.866667 or 1.3—the annual value.
4. Divides the accrual by 12 to get the monthly accrual and passes it to the pro rata \_ENT and \_BAL accumulators
5. The annual value is deannualized to the absence calendar frequency and that amount of entitlement.

The absence take, LSL TKEWKO, related to both the pro rata and entitlement absence elements (indicating that pro rata days can be used despite not having become entitlement yet), firsts looks to the entitlement balance to decrement absence units before looking to the pro rata balance to further decrement absence units (where the entitlement units are depleted).

The units (weeks) to decrement is resolved by the formula LVE FM WKO CALC, which does the same thing as LSL TKEWKF's day formula LVE FM WKF ABS NPH. The formula LVE FM WKO CALC is not, however, LSL TKEWKO's day formula. It is called by LSL TKEWKO's day formula, LVE FM WKO ABS ST, which has to check the state before resolving the daily hours into the take's number of weeks.

The formula LVE FM ABS ST determines whether the state value is NSW, QLD, or TAS and the day is not a public holiday; if that is the case, it resolves the day's hours into a fraction of a week using LVE FM WKO CALC. If the day is a public holiday in one of those states, the formula does not resolve the day's hours.

If the state is not NSW, QLD, or TAS, the day's hours are resolved by LVE FM WKO CALC, regardless of whether the day is a public holiday.

## Accruing and Taking Sick Leave

This section discusses each of the sick leave entitlements and their respective absence takes.

### Accruing and Taking Variable Sick Leave—Days

This sick leave absence entitlement, SCK ENTDYS V, determines the correct sick leave grant of accrual that is to be 8 days in the first year and 10 days in subsequent years.

1. The entitlement's formula, SCK FM ENTDYS VI, grants the initial accrual by verifying that the `_ENT` balances is 0; if it is zero, it retrieves a value of 8 from bracket SCK BR DYS V. The bracket uses duration GP YEARS OF SVC and it returns 8 (days) if there are no years of service (this is the employee's first year and the duration cannot return decimals of a year). A 0 duration returns bracket value 8.

2. When the absence calendar is run, the bracket value 8 is accrued to the year-to-date `_ENT` and `_BAL` accumulators.

The accumulators are stored by EMPL ID/EMPL RCD and begin on the hire date.

3. The absence take, SCK TKE DYS V, uses the absence entitlement balance to decrement absence units (days).

Eligibility criteria defined on the take (on the Period page of the take component) do not allow any payment of sick leave in the first three months of hire or rehire. The date element SCK DT WAIT 3/12 calculates the three-month period. It adds three months to the hire or rehire date, and that is the date on which the employee is eligible for the accrual.

4. The units (days) to decrement is resolved by the take's day formula, LVE FM DYS ABS PH, which is the same formula that annual leave take ANN TKEDYS uses.

5. The units returned become the paid units (DAY COUNT PD) and unpaid units (DAY COUNT UNP), depending on available absence entitlement days.

6. The positive input for this absence take are earnings SCK and LWOP.

The units for these earnings are formulas LVE FM DY DCP HRS and LVE FM DY DCUP HRS respectively. The formulas multiply the DAY COUNT PD and DAY COUNT UNP by the scheduled hours so the system can pay the leave in hours.

7. When the system creates a new instance of the year-to-date accumulator SCK ENTDYS V\_ENT on the employee's hire or rehire anniversary, the accumulator's initialize rule, SCK FM ENTDYS V, checks bracket SCK BR DYS V again.

This time, because GP YEARS OF SVC returns 1, the bracket returns 10.

#### Note

If the Use Next Lower interpolation method is set on the bracket's Lookup Rules page, the bracket returns 10 even when years of service are more than 1.

### Accruing and Taking Fixed Sick Leave—Days

This sick leave absence entitlement, SCK ENTDYS F, determines the correct sick leave grant of accrual that is 10 days per year pro rated for the first year. The accrual is granted on January 1 for all employees.

1. The entitlement's formula, SCK FM ENTDYS FI, grants the initial accrual by verifying that the \_ENT balances is 0; if it is 0, it retrieves a value from bracket SCK BR DYS F.  
  
The bracket uses duration SCK DR REST OF YR, which calculates the period of time from hire (or rehire) to the end of the year and returns the duration as a decimal fraction of a year. The bracket prorates the 10 days maximum yearly accrual according to that fraction; for example, for a duration of 0.2 of a year, the accrual is 2 days.
2. The absence take, SCK TKE DYS F, uses the absence entitlement balance to decrement absence units (days).
3. The units (days) to decrement is resolved by the take's day formula, LVE FM DYS ABS PH, which is the same formula that annual leave take ANN TKEDYS and SCK TKEDYS V uses.
4. The units returned become the paid units (DAY COUNT PD) and unpaid units (DAY COUNT UNP), depending on available absence entitlement days.
5. The positive input for this absence take is the same as for SCK TKEDYS V.
6. When the system creates a new instance of the year-to-date accumulator SCK ENTDYS F\_ENT at the end of the calendar year, the accumulator's initialize rule, SCK FM 1ST JAN, checks bracket SCK BR DYS F again.

Because the bracket's duration returns 1 this time, the bracket returns 10.

#### ① Note

The duration's To date is date element SCK DT 31ST DEC. The date's month and day are 12 and 31, respectively. Its year is the variable LVE VR PRD END YR. Therefore, as soon as the leave process is run in a new year, the duration always returns greater than one year, so the bracket always returns 10.

### Accruing and Taking Pro Rata and Entitlement Sick Leave—Hours

The pro rata, entitlement and take processing of hours per year sick leave is the same as the annual leave days per year pro rata and entitlement, except it is in hours not days. The accrual is 76 hours per year.

1. The two entitlement elements are SCK PROHRS and SCK ENTHRS, and the pro rata element calculates the accrual and passes it from its own \_ENT and BAL accumulators to the entitlement's ENTHRS \_ENT and \_BAL accumulators on the employee's hire anniversary.
2. The pro rata entitlement formula is SCK FM ENTHPY, which prorates an employee's standard work hours as a fraction of their leave entitlement standard hours.  
  
(Standard weekly hours for employee ÷ Entitlement standard weekly hours) × Annual entitlement  
  
(35 ÷ 38) × 76 = 70 (rounded)
3. The take element that uses the entitlement and pro rata elements SCK TKEHRS uses day formula LVE FM HRS ABS PH, the same as the annual leave days per year pro rata and entitlement.

## Accruing and Taking Leaves During Foreign Employment Period

When an employee starts working in another country (i.e., the foreign employment period) for the first time, the accumulated unused leave balances pertaining to annual and long service leave till the time he/she enters the foreign employment, are moved to normal employment accumulators for the respective leave types. And the leaves accrued during the foreign employment are added to the foreign employment accumulators. During the foreign employment period, any absence taken by the employee is deducted from the foreign employment balance accumulators, provided there is enough balance in the respective leave types (Annual and Long Service Leave). If there is no sufficient balance available in the foreign employment accumulators, the number of days/hours absent is deducted from the normal employment accumulators.

Once the foreign employment period is complete and the employee is back to normal employment (in Australia), his/her foreign employment unused balance accumulation stops and the unused leaves get accrued in the normal employment balance accumulators.

<b>Accumulators for Normal Employment Leave Balances</b>	<b>Accumulators for Foreign Employment Leave Balances</b>
ANN LVEDYS NR_BAL Normal Employment Annual Leave Days Balance accumulator	ANN LVEDYS FR_BAL Foreign Employment Annual Leave Days Balance Accumulator
ANN LVEHRS NR_BAL Normal Employment Annual Leave Hours Balance accumulator	ANN LVEHRS FR_BAL Foreign Employment Annual Leave Hours Balance accumulator
ANN LVEHPH NR_BAL Normal Employment Annual Leave Hour per Hour Balance accumulator	ANN LVEHPH FR_BAL Foreign Employment Annual Leave Hour per Hour Balance accumulator
LSL PROWKF NR_BAL Normal Employment LSL Federal balance accumulator	LSL PROWKF FR_BAL Foreign Employment LSL Federal balance accumulator
LSL PROWKO NR_BAL Normal Employment LSL Other States balance accumulator	LSL PROWKO FR_BAL Foreign Employment LSL Other States balance accumulator

<b>Adjustment Variables</b>	<b>Balance Accumulators</b>
AN VR NR LVDS ADJ — To adjust the Normal Employment Annual Leave Days Balance.	ANN LVEDYS NR_BAL Normal Employment Annual Leave Days Balance accumulator
AN VR FR LVDS ADJ — To adjust the foreign employment Annual leave days balance.	ANN LVEDYS FR_BAL Foreign Employment Annual Leave Days Balance Accumulator
AN VR NR HRS ADJ — To adjust the normal employment Annual leave hours balance.	ANN LVEHRS NR_BAL Normal Employment Annual Leave Hours Balance accumulator
AN VR FR HRS ADJ — To adjust the foreign employment Annual leave hours balance.	ANN LVEHRS FR_BAL Foreign Employment Annual Leave Hours Balance accumulator
AN VR NR HPH ADJ — To adjust the normal employment Annual leave hour per hour balance.	ANN LVEHPH NR_BAL Normal Employment Annual Leave Hour per Hour Balance accumulator
AN VR FR HPH ADJ — To adjust the foreign employment Annual leave HPH balance.	ANN LVEHPH FR_BAL Foreign Employment Annual Leave Hour per Hour Balance accumulator
LS VR NR WKF ADJ — To adjust the normal Employment LSL WKF Balance.	LSL PROWKF NR_BAL Normal Employment LSL Federal balance accumulator
LS VR FR WKF ADJ — To adjust the foreign Employment LSL WKF Balance.	LSL PROWKF FR_BAL Foreign Employment LSL Federal balance accumulator

Adjustment Variables	Balance Accumulators
LS VR NR WKO ADJ — To adjust the normal Employment LSL WKO Balance.	LSL PROWKO NR_BAL Normal Employment LSL Other States balance accumulator
LS VR FR WKO ADJ — To adjust the foreign Employment LSL WKO Balance.	LSL PROWKO FR_BAL Foreign Employment LSL Other States balance accumulator

## Accruing and Taking Other Types of Leave

This section discusses the rules for processing the following other types of leave:

- Workers' compensation.
- Maternity leave.
- Leave without pay.
- Jury service.

These types of leave are *per absence* entitlements, not frequency-based entitlements. They have the following common characteristics:

- They are all based on a generic entitlement GENERIC ENT, for which the entitlement is formula LVE FM ENT HRS. GENERIC ENT also has the conditional formula LVE FM SCHED HRS (per absence entitlements must have a conditional formula).
- The individual takes for these absences all use entitlement GENERIC ENT.
- The individual takes for these absences all map to earnings OTHLV (except LWOP, which maps to LWOP).
- Earnings OTHLV's calculation rule is Unit × Rate, where Unit is payee level (positive input by the take processing) and Rate is hourly rate (LWOP has the same calculation rule but its rate is variable 0).
- The individual takes for these absences all use the day formula LVE FM HRS ABS PH, which is the same day formula used by the takes for Annual Leave—Hours, Annual Leave Hours per Hour, and Sick Leave—Hours.
- None of the elements have a qualifying eligibility period except the maternity take.

## Processing Other Leaves

This section discusses the general processing of per absence entitlement and explains the single exception.

1. The take's day formula determines the hours to be paid for each day in the leave period.
2. The absence entitlement's formula determines how many hours to grant as entitlement—either the partial hours or the scheduled hours.

The conditional formula then verifies that there are scheduled hours (that is, the employee would have been working). If there are scheduled hours, the entitlement is granted for the hours that the day formula has determined.

3. The taken hours, to which the employee is entitled according to the entitlement and conditional formulas, become DAY COUNT PD units for the earnings OTHLV or LWOP.

(There are no DAY COUNT UNP days because entitlement always equals the leave duration requirement.)

The take for maternity leave, MATERNITY TKE, has period eligibility formula LVE FM MAT QUAL DT. The two conditions are:

- The duration of the leave is not more than one year.
- The employee has worked for a year or more.

The formula uses duration LVE DR MAT QUAL to check the first condition and the date LVE FM MAT QUAL DT to check the second.

## Calculating and Taking OGO Long Service Leave

This topic provides an overview of OGO long service leave and discusses ways to calculate and take long service leave.

### Page Used to Calculate and Take Long Service Leave

Page Name	Definition Name	Usage
<a href="#">Define Prior Service AUS Page</a>	GPAU_LSL_HISTORY	Enter details of periods of service.

### Understanding OGO Long Service Leave

The rules for long service leave accrual and take for the Commonwealth Government (referred to as OGO) depend on data entry of prior and current service periods. The rules calculations include such things as full- or part-time work, an adjusted service date, days between different periods of service, and non-service days.

#### Note

Any organization can use this LSL processing method if it suits its business practice.

Leave is accrued as either part-time or full-time pro rata and entitlement, depending on the type of employment at the time of accrual.

This long service leave is based on three months' leave after 10 years, so the accrual rate is:

$3 \text{ months} \div (12 \text{ months} \times 10 \text{ years}) = 0.025 \text{ months per month.}$

Pro rata leave becomes entitlement after the first 10 years and, thereafter, annually.

For the system to correctly calculate an employee's pro rata and entitlement balances—full- and part-time—you must record the employee's prior service history initially and thereafter maintain their current service history. Do this on the Define Prior Service AUS page.

#### Note

The elements that calculate long service leave—including the division between pro rata and entitlement—access the data entered on the Define Prior Service AUS page each time that you run an absence calendar, so it must be up-to-date.

Each time you run an absence calendar, the system:

- Recalculates the adjusted service date.
- Recalculates the duration from the adjusted service date to current period end date.
- Subtracts the between service days.
- Subtracts non service days.
- Determines which part of the remaining duration accrues pro rata LSL leave and which part accrues entitlement LSL leave.
- Determines how much of the entitlement is part-time leave and how much is full-time leave.
- Checks for leave takes and reduces the part-time or full-time entitlement calculations by the amount of the take.
- Calculates the part-time average hours for part-time leave takes.

#### Note

Only the pro rata full-time absence entitlement, PSH LSLPROFT, initiates the LSL accrual process rule using its entitlement calculation formula PSH FM LSL ENTLMNT. Absence entitlements PSH LSLPROPT, PSH LSENTPT, and PSH LSENTFT have numeric 0.00 as the entitlement calculation. When the rule has finished, the system updates \_ENT, \_BAL, and \_TKE accumulators for all four absence entitlements.

## Define Prior Service AUS Page

Use the Define Prior Service AUS page (GPAU\_LSL\_HISTORY) to enter details of periods of service.

Navigation:

**Global Payroll & Absence Mgmt**, and then **Payee Data**, and then **Maintain Absences**, and then **Define Prior Service AUS**, and then **Define Prior Service AUS**

This example illustrates the fields and controls on the Define Prior Service AUS page. You can find definitions for the fields and controls later on this page.

**Define Prior Service AUS**

Jane Taylor Employee Empl ID KA0001 Empl Record 0

Service History Personalize | Find | First 1 of 1 Last

	*Start Date	End Date	*Employer	Part Time	Non Service Days	Full Time Taken	Part Time Taken	
1	<input type="text"/>	<input type="text"/>	<input type="text"/>	<input type="checkbox"/>	<input type="text"/>	<input type="text"/>	<input type="text"/>	<input type="button" value="+"/> <input type="button" value="-"/>

Field or Control	Description
<b>Start Date and End Date</b>	Enter the start and end dates of the service period. <b>Note:</b> Enter service periods in any order. The system sorts them from newest to oldest when you save and refresh the page.
<b>Employer</b>	This is for information only. It is free-form text box
<b>Part Time</b>	Select this check box if the service period is part-time. The <b>Std Hrs/Week</b> field appears, where you can enter the average standard weekly hours for the period. The system uses the values in the calculation of the average weekly hours when determining the payment unit for part-time leave takes.
<b>Non Srv Days</b> (non service days)	Enter your manually calculated non-service days. These are the days in the employment period that do not accrue long service leave. <b>Note:</b> The accrual calculation includes <i>any</i> value that you enter here. No validation of rules exist, such as <i>Count only if greater than 30 days in a calendar year</i> .
<b>F/T Taken</b> (full-time taken) and <b>P/T Taken</b> (part-time taken)	Enter the duration of the leave take in decimal months (number of days ÷ 30).

 **Note**

The system calculates the between-service days from the date that you enter here. It is the duration in days of the period between the end date of one service period and the start date of the next.

The following table shows how the fields populate the variables through array PSH AR SVC PRD ROW.

Field	Variable
Start Date	PSH VR SP START DT
End Date	PSH VR SP END DT
Part Time	PSH VR SP PT IND
Std Hrs/Week	PSH VR SP PT HRS
Non Srv Days	PSH VR SP NSD
P/T Taken	PSH VR SP TP TKNM
F/T Taken	PSH VR SP FT TKNM

## Calculating the Adjusted Service Date

The system adjusts the initial service start date before calculating the duration of the service period upon which the accrual is based. For this adjustment, on-service days and between-

service days are totalled then added to the lowest (earliest) start date to reset the lowest start date to a later date.

This diagram shows how non-service days and between-service days are totalled then added to the lowest (earliest) start date to reset the lowest start date to a later date. The variable and date elements are also shown.

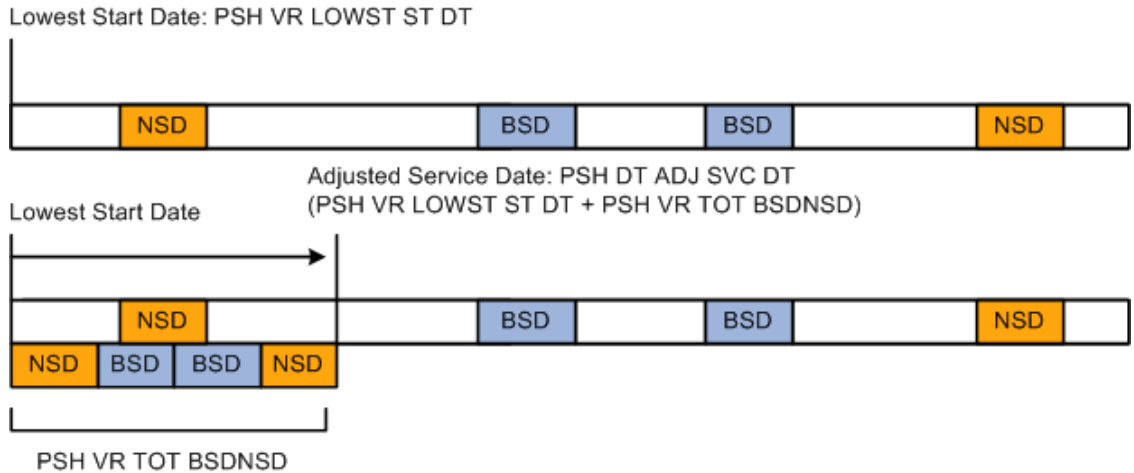

## Calculating OGO Part- and Full-Time Pro Rata and Entitlement

When you run an absence calendar, the system recalculates *all* of the accrued part-time and full-time pro rata and entitled long service leave. The following two diagrams show the accumulators are increased—at 0.025 per month—for an absence calendar run, after 9 years of service and after 12.5 years of service. Both the `_ENT` and `_BAL` accumulators for the four accruals are updated. The accumulators are calendar period based.

This diagram shows updated leave accumulators after 9 years.

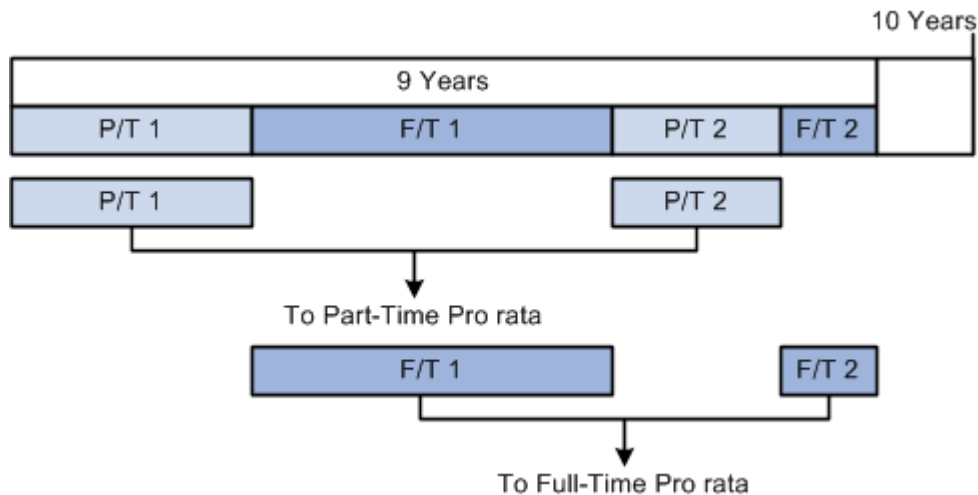

This diagram shows updated leave accumulators after 12.5 years.

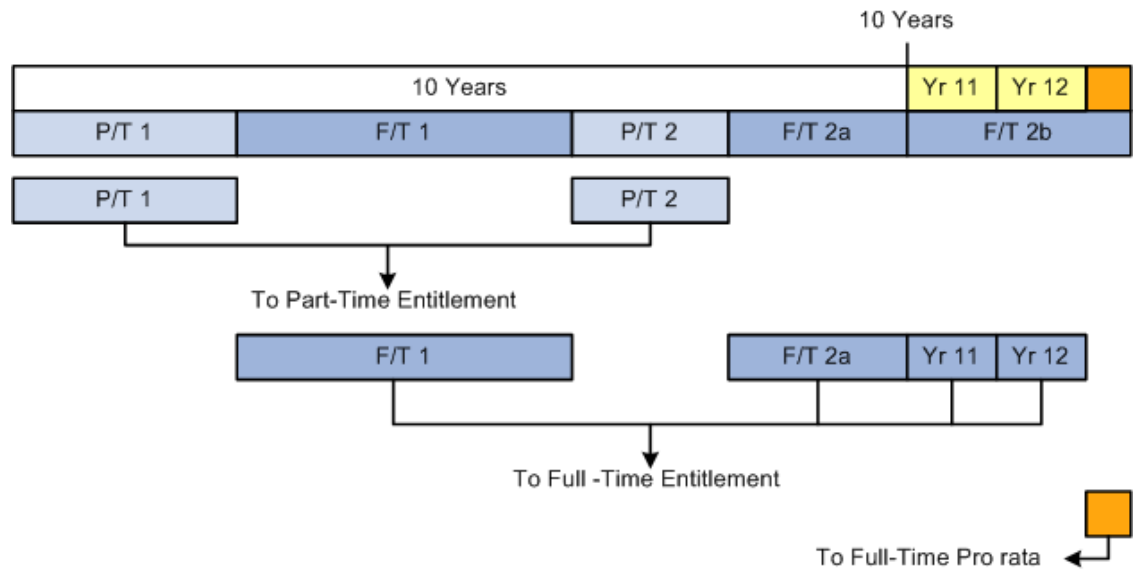

## Taking OGO Long Service Leave

The two absence take elements PSH LSLTKEPT and PSH LSLTKEFT have the same day formula, LVE FM MTH ABS PH. The formula resolves in a similar way to the Federal LSL take. It checks for a public holiday, partial or scheduled hours, and an adjustment made through the **User Defined 1** field on the Absence Event Input Detail page. However, each day's hours are converted to months by dividing by the standard hours per month (LVE FM MT STD HRS).

### Note

The two takes only check entitlement balances. Pro rata LSL cannot be taken.

The months returned become the paid units (DAY COUNT PD) and unpaid units (DAY COUNT UNP), depending on available absence entitlement weeks.

The positive input for these absence takes are the earnings elements LSL and LWOP.

The full-time units for these earnings are formulas LVE FM MT DCP HRS and LVE FM MT DCUP HRS, respectively.

The formulas multiply the DAY COUNT PD and DAY COUNT UNP (both in months) by the employee's standard monthly hours (hours from the Job record, annualized and deannualized to hours per month) so the system can pay the leave in hours at the employee's hourly rate.

The part-time units for these earnings are formulas LVE FM MT PTDCP H and LVE FM MT PTDCUP H, respectively. When calculating the units for part-time accrued LSL, the system must determine the average monthly hours for the employee over the entire period of service.

The average weekly hours value is the greater of:

- The average of all part-time periods in the whole period of service.
- The average of the last 12 months of part-time service if there is any part-time service in the last 12 months.

The average monthly hours replace the standard monthly hours (multiplied by the hourly rate) used for full-time LSL.

### Note

The processing of taken leave for OGO LSL does not include decrementing entitlement balances. You must add any taken part-time or full-time leave on the Define Prior Service AUS page for the employee, and the accrual rules adjust the balances.

## Paying Leave in Advance

To set up leave pay in advance, use the Advance Types AUS (GPAU\_ADV\_TYPES) component.

Periods of leave and regular pay can be paid in a period (or calendar) earlier than the period (or calendar) in which they are normally.

## Pages Used to Pay Leave in Advance

Page Name	Definition Name	Usage
<a href="#">Advance Types AUS Page</a>	GPAU_ADV_TYPES	Define the first and last period advance processing options and link absence takes to the advance type.
<a href="#">Pay In Advance AUS Page</a>	GPAU_ABS_EVENT_ADV	Enter an advance type and view the details of advance payments.

## Advance Types AUS Page

Use the Advance Types AUS page (GPAU\_ADV\_TYPES) to define the first and last period advance processing options and link absence takes to the advance type.

Navigation:

**Set Up HCM**, and then **Product Related**, and then **Global Payroll & Absence Mgmt**, and then **Elements**, and then **Absence Elements**, and then **Advance Types AUS**, and then **Advance Types AUS**

This example illustrates the fields and controls on the Advance Types AUS page. You can find definitions for the fields and controls later on this page.

**Advance Types AUS**

Advance Type KALEAVE  
 \*Description Advance Leave Only Short Description Leave Only

**Calendar Group Selection**

\*Advance Calendar Group Period Prior to Absence  Allow Override

**Advance Processing Options** Personalize | Find | View All | First 1-2 of 2 Last

*Run Type	*First Period	*Last Period	*Gap		
1 KAABSENCE	Advance Whole Period	Advance Whole Period	Pay in Advance	+ -	
2 KAPAYROLL	Advance Absence, Reg in Normal	Advance Absence, Reg in Normal	Pay in Normal Calendar Group	+ -	

**Valid Absence Takes** Personalize | Find | View All | First 1-4 of 4 Last

*Element Name	Description		
1 ANN TKEHRS	Annual Lve Take Hours Entitle	+ -	
2 ANN TKEDYS	Annual Leave Take Days Entitle	+ -	
3 ANN TKEHPH	Ann Lve Take HoursPerHour Ent	+ -	
4 LSL TKEWKF	LSL Take Federal Entitlement	+ -	

These are the key points about advance types:

- You define which periods are advanced for an absence.
- You specify the absence takes with which the advance type can be used.
- A single advance type can be used with multiple absence takes.
- Multiple advance types can use the same absence takes.
- When you specify the absence take on an absence event entry, you can select only advance types with which the take has been associated.
- If an absence take has not been associated with any advance types, you cannot pay the absence in advance when you specify that take for an event (because you can't select an advance type).

### Calendar Group Selection

Field or Control	Description
<b>Advance Calendar Group</b>	<p>Select to determine the calendar group in which to pay the advance. Select from:</p> <p><i>Payment After Absence Begin:</i> The advance is paid in the calendar group that contains the first payment date after the absence begins.</p> <p><i>Payment Prior to Absence Begin:</i> The advance is paid in the calendar group that contains the last payment date prior to the absence begin date.</p> <p><i>Period Absence Begins:</i> The advance is paid in the calendar group that contains the period in which the absence begins.</p> <p><i>Period Prior to Absence:</i> The advance is paid in the calendar group that contains the period immediately prior to the one in which absence begin date falls.</p>

Field or Control	Description
<b>Allow Override</b>	Select to enable an override of the calendar group that the system selects. The system calculates the calendar group using the preceding options above, but you can override it on the Pay in Advance AUS page of the Absence Event AUS component.

### Advance Processing Options

Field or Control	Description
<b>Run Type</b>	<p>Select a run type. You need to set up the advance processing options for each run type because absence run types generally need to be treated differently from payroll runs. For the system to calculate absences correctly, they must run in the correct sequence. The system does not calculate absences correctly if the previous period's entitlements have not already been accrued. For absence run types, therefore, the options are usually set up to advance the whole first period and the gap period, regardless of the options set for the payroll run types.</p> <p><b>Note:</b> An exception exists if an absence entitlement accrual is based on actual hours worked, such as ANN ENTHPH. This situation reverses the normal absence-then-payroll run sequence to payroll-then-absence. In this situation, you need to define a separate process list (for example, HRLY ACCRUED) with the hours-per-hour entitlement in a section (for example, ABS ENTHPH SEC) in that process list. You then need to create a separate run type for this process list and that run type needs to have the same first period and last period options as the payroll run type.</p>

### First Period and Last Period

These options determine how the system handles the period in which the absence begins. Select from the following values:

*Advance Absence, Reg in Normal* (regular in normal): Only the part of the period while on absences is advanced. The rest of the period is paid in its normal calendar group.

*Advance Absence, Reg on Return* (regular on return): Only the part of the period while on absences is advanced. The rest of the period is paid after the absence.

**Note:** This is not an option for the last period.

*Advance Whole Period:* The entire period is paid in advance.

*No Advance:* The period is not advanced at all. It is paid at the normal time.

Field or Control	Description
<b>Gap</b>	<p>A <i>gap</i> occurs when a pay period is before the absence but the payment date falls during the absence. Select from the following values:</p> <p><i>Advance</i>: The gap is paid in advance.</p> <p><i>Normal</i>: The gap is paid at the normal time.</p> <p><i>On Return</i>: The gap is paid at the normal time.</p>

**Valid Absence Takes**

Field or Control	Description
<b>Element Name</b>	Enter the absence take with which this advance type can be used.

**Examples of Gap Processing**

The following two diagrams show the On Return and Normal gap options in effect. For both scenarios, the first period and last period options are *Advance Whole Period*. A diamond indicates the advanced leave payment date and an asterisk indicates the gap pay date.

This diagram illustrates *On Return* gap processing.

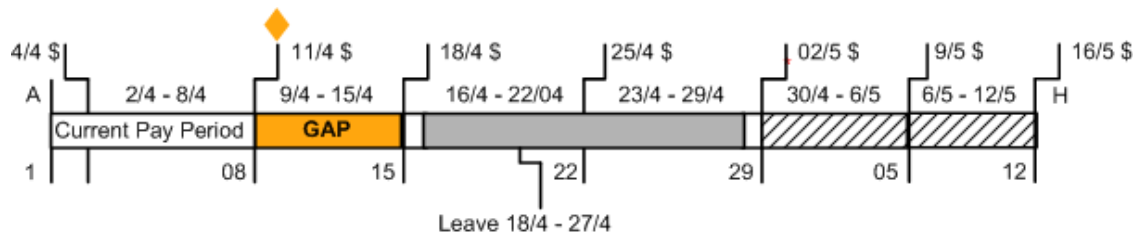

Regular, Leave, and Gap Dates	Pay Period
16/4 - 17/4 Regular	Pay Period Ending 08/4 (Paid 11/4)
18/4 - 27/4 Leave	Pay Period Ending 08/4 (so paid 11/4)
28/4 - 29/4 Regular	Pay Period Ending 08/4 (so paid 11/4)
09/4 - 15/4 Gap	Pay Period Ending 29/04 (so paid 02/5)

This diagram illustrates *Normal* gap processing.

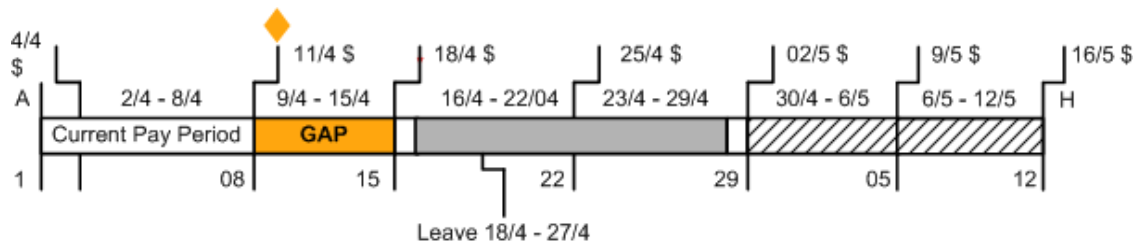

Regular, Leave, and Gap Dates	Pay Period
16/4 - 17/4 Regular	Pay Period Ending 08/4 (Paid 11/4)
18/4 - 27/4 Leave	Pay Period Ending 08/4 (so paid 11/4)
28/4 - 29/4 Regular	Pay Period Ending 08/4 (so paid 11/4)
09/4 - 15/4 Gap	Pay Period Ending 29/04 (so paid 18/4)

## Pay In Advance AUS Page

Use the Pay In Advance AUS page (GPAU\_ABS\_EVENT\_ADV) to enter an advance type and view the details of advance payments.

Navigation:

**Global Payroll & Absence Mgmt**, and then **Payee Data**, and then **Maintain Absences**, and then **Absence Event AUS**, and then **Pay in Advance AUS**

This example illustrates the fields and controls on the Pay in Advance AUS page. You can find definitions for the fields and controls later on this page.

The screenshot shows the 'Pay in Advance AUS' page for employee Maria Cortes (Employee ID KA0003, Empl Record 0). The page includes a 'Payment Advance Details' section with fields for 'Absence Take', 'Advance Type', 'Begin Date', and 'End Date', along with a 'Calculate Advance' button. Below this are two main sections: 'Advance Payments' and 'Return Payments'. Each section contains a table for 'Calendar Periods' with columns for 'Pay Group', 'Calendar ID', 'From', 'To', 'Original Pay Date', and 'Original Calendar Group'. The 'Advance Payments' table shows one entry with 'Pay Group' 1. The 'Return Payments' table also shows one entry with 'Pay Group' 1. Navigation and search options are available for both tables.

This page is an addition to the Absence Event component. The page displays details of the advance payment according to the advance type that you enter.

Enter the advance type for the absence event. When you click the **Calculate Advance** button, the system displays information about how and when the advance payment is made based on the rules for the advance type.

The system displays the information in two group boxes, **Advance Payments** and **Return Payments**.

**Advance Payments**

Field or Control	Description
<b>Advance Cal Grp</b> (advance calendar group)	This is the calendar group for the advance payment.
<b>Payment Date</b>	This is the payment date of the regular pay calendar in the calendar group.
<b>Period</b>	These are the From and To dates of the regular pay calendar in the calendar group.

**Calendar Periods Advanced**

Field or Control	Description
<b>Pay Group</b>	This is the pay group in which the payment would be made if it were not advanced.
<b>Calendar ID</b>	This is the calendar in which the payment would be made if it were not advanced.
<b>From and To</b>	These are the From and To dates of the period being advanced.
<b>Orig Pay Dt</b> (original payment date)	This is the payment date when the payment would be made if it were not advanced.
<b>Orig Cal Grp</b> (original calendar group)	This is the calendar group in which the payment would be made if not it were not advanced.

**Return Payments**

Field or Control	Description
<b>Return Cal Grp</b> (return calendar group)	This is the calendar group in which any unadvanced payment is made. <b>Note:</b> None of the Return Payments fields are populated if the advance type advances all pay from the period in which the leave occurs, or if the advance type advances some of the pay and pays the balance in its normal period.
<b>Payment Date</b>	This is the payment date of the regular pay calendar in the calendar group.
<b>Period</b>	These are the From and To dates of the regular pay calendar in the calendar group.

**Calendar Periods Paid on Return**

Field or Control	Description
<b>Pay Group</b>	This is the pay group in which the payment would have been made if not paid on return.
<b>Calendar ID</b>	This is the calendar in which the payment would have been made if not paid on return.
<b>From and To</b>	These are the From and To dates of the period being paid on return.

Field or Control	Description
<b>Orig Pay Dt</b> (original payment date)	This is the payment date for the calendar in which the payment would have been made if not paid on return.
<b>Orig Cal Grp</b> (original calendar group)	This is the calendar group in which the payment would have been made if not paid on return.

#### Note

If you select the **Allow Override** check box when you define the advance type, you can override the advance or return calendar group the system selected for this advance. You cannot, however, change any calendars or calendar data for a system-selected or overridden calendar group.

For leave be correctly paid in advance, you must specify a regular run type in the **Leave Paid in Advance** group box on the Pay Groups AUS page (select **Set Up HCM**, and then **Product Related**, and then **Global Payroll & Absence Mgmt**, and then **Framework**, and then **Organizational**, and then **Pay Groups AUS**).

You must select the check box on the Australian Information page for all of the calendars that can be advanced (select **Set Up HCM**, and then **Product Related**, and then **Global Payroll & Absence Mgmt**, and then **Framework**, and then **Calendars**, and then **Calendars Groups AUS**).

#### Related Topics

- [Entering Additional Pay Group Information](#)  
To enter additional pay group information, use the Pay Groups AUS (GPAU\_PYGRP\_DTL) component.
- [Entering Additional Calendar Information](#)  
To set up additional calendar information, use the Calendar Groups AUS (GPAU\_CAL\_RUN) component.

# 18

## Understanding Termination Payment Management

### Termination Processing

When an employee's services are terminated, regardless of the reason, the employer must make mandatory payments to the employee, depending on the circumstances. Payments can consist of:

- Final wages.
- Unused leave entitlements.
- Redundancy and retrenchment payments.
- Early retirement.
- Invalidity and disability payments.
- Pay in lieu of notice (considered an ETP).
- Ex gratia payments (considered an ETP).

The calculation of these payments can vary from organization to organization depending on the reason for termination.

### Termination Earning Elements

The Termination section comprises a formula, 21 earning elements, and a single deduction. They ensure that all legal obligations are met and that you have the flexibility to make changes to suit your business practices. You need to maintain only a few of the formulas upon which the earnings are based. You also have to set the values of some of the variables that the formulas use.

### The Termination Section

The Termination section contains a conditional formula, TER FM TERM CHECK, to check if there is either a termination date in the pay period or a termination action date in the period. The formula checks for both to accommodate a situation in which you may have not entered the termination until the pay period after the period in which the termination occurred. If the check is only on the termination date, the section is not processed, because that date is outside the current pay period begin and end dates.

This diagram shows the process of checking for a termination date or termination action date.

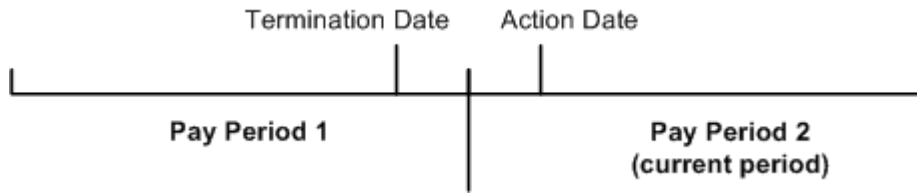

The check shows that the Termination section should be processed even though the termination date was in the previous pay period.

## Offset Days for Retroactive Termination Triggers

When you define retro triggers on the Trigger Definitions-Field Values page, you can enter a positive or negative number in the Offset Days field to increase or decrease the retro trigger effective date in relation to the date of a field value change. For example, if you enter -1 in the Offset Days field for one of the values listed in the Field Values group box, and you retroactively enter that value into the database with an effective date of January 1, 2000, the system automatically adjusts the trigger effective date to December 31, 1999 (one day earlier). The system then processes pay periods going back to December 1999 rather than January 2000. Global Payroll for Australia uses the offset days feature to define the triggers for retroactive terminations entered in the JOB record using the Action field:

This example of the Trigger Definitions-Field Values page shows Australia JOB actions that trigger retroactive termination processing.

Trigger Setup-Values x

---

Trigger Definitions

**Field Values**

Country AUS Australia  
Record (Table) Name JOB  
Field Name ACTION

Field Values				
*Sequence	*Character Value	*Trigger Event ID	Offset Days	
1	HIR	JOB	0	+ -
2	TER	JOB	-1	+ -
3	RET	JOB	-1	+ -

No Match on Field Value Option

Do Not Trigger

Trigger Using Specified Event

Trigger Event ID

Note that the offset for the termination actions *TER*, *RET*, *RWP*, *TWP*, and *TWB* is -1.

The reason for this offset is that the PeopleSoft system considers the effective date of a termination entered in the **Action** field in JOB to be the first day that a payee is no longer working (in other words, the day before the termination is the last day the payee is considered

active); however, the effective date of the trigger generated in response to this termination is identical to the termination date. This can create problems when the termination date in the JOB record is equal to the pay period begin date (meaning, the last day worked is the last day of the prior pay period). For example, assume that you enter a termination in JOB on February 1 after processing and closing the January calendar. In this situation, the system generates a trigger with an effective date of February 1, which is within the current period—a period in which the payee is "inactive" and is not picked up for processing. Because there is no trigger in the prior, closed period (January), this period will not be recalculated and any rules set up to generate termination payments will not be processed. To avoid this problem, Global Payroll for Australia sets the offset days for the *TER* (termination), *RET* (retirement), *RWP* (Retirement with Pay), *TWP* (termination with pay), and *TWB* (termination with benefits) action values in the JOB record equal to -1.

**! Important**

If you define additional action values to trigger retroactive termination payments, you should set the offset days to -1.

## Delivered Termination Earnings

This table lists the earning elements resolved in the Termination section and each earning calculation rule. Individual elements are later discussed in sufficient detail for you to understand how they are correctly resolved. The code (*gc*) in the first column indicates that the earning has a generation control:

Name and Description	Unit	Rate	Percent	Amount
AL MARGINAL Ann Lve - Marginal (Term) (gc)	TER FM AL BAL HRS	TER FM HOURLY RATE		
AL MARGIN DY Ann Lve - Marginal (Term Days) (gc)	TER FM AL BAL DYS	TER FM DAILY RATE		
LSL MARGINAL LSL - Marginal (Term)	TER VR LS MARGINAL	TER FM DAILY RATE		
LL MARGINAL Lve Loading - Marginal(Term) (gc)	TER FM LL BAL HRS	TER FM HOURLY RATE	17.5	
LL MARGIN DY Leave Load on Term (Days-MAR) (gc)	TER FM LL BAL DYS	TER FM DAILY RATE	17.5	
AL LUMP A Annual Leave - Lump Sum A	TER FM AL BAL HRS	TER FM HOURLY RATE		

Name and Description	Unit	Rate	Percent	Amount
AL LUMPA DY Ann Lve Lump sum A (Term Days) (gc)	TER FM AL BAL DYS	TER FM DAILY RATE		
LSL LUMP A LSL - Lump Sum A	TER VR LS LUMPA	TER FM DAILY RATE		
LL LUMP A Leave Loading - Lump Sum A (gc)	TER FM LL BAL HRS	TER FM HOURLY RATE	17.5	
LL LUMPA DY Leave Load on Term (Days-LSA) (gc)	TER FM LL BAL DYS	TER FM DAILY RATE	17.5	
LSL LUMP B LSL - Lump Sum B	TER VR LS LUMPB	TER FM DAILY RATE		
TERM LUMP D Termination - Lump Sum D				TER FM LUMPD
INV POST 94 Invalidity Post 94 Component				TER FM INV POST94
REDUNDANCY				Payee Level
EX GRATIA				Payee Level
PAY IN LIEU				Payee Level
INVALIDITY				Payee Level
INV POST 94				TER FM INV POST94
ETP ER LBP Earning for Full ETP Cap				Payee Level
ETP ER WIC Earning for minimum of ETP/ Whole Income Cap				Payee Level
ETP WIC TAX Tax on Other ETP Earning				TAX VR ETP WIC
ETP NTAX WIC Non Taxable Other ETP Earning				TER VR ETPWIC PR83
ETP TAX WIC Taxable Other ETP Earning				TER VR ETPWIC PT83

Name and Description	Unit	Rate	Percent	Amount
AL FR LUMP A Foreign Employment Annual Leave Lump Sum A	TER FM AL FR BL HR	TER FM HOURLY RATE		
AL FR LMPADY Foreign Employment Annual Leave LUMP SumA- Days	ANN LVEDYS FR_BAL	TER FM DAILY RATE		
LS FR LUMP A Foreign Employment LSL- Lump Sum A	TER FM FR LSL BAL	TER FM DAILY RATE		

## Calculation of Hourly and Daily Rates

All the rates are either hourly or daily. For both, we have allowed for the situation in which employees have salary packages and need to have their hourly or daily rate calculated from their total package value.

### Calculating the Hourly Rate

To calculate the hourly rate, use the formula TER FM HOURLY RATE to:

- Determine if the employee is salary-packaged by checking for a value for rate code AUTVP.  
If there is no value for AUTVP, the system uses the employee's hourly rate.
- Retrieve the employee's standard hours frequency from the Job record in the **Work Period** field and passes it to AUS VR TEMP FREQUENCY.
- Use the variable to get the annualized factor AUS VR ANNL FCTR from the array AUS AR FREQUENCY.
- Divide AUTVP by the annualized factor, then divides by the employee's standard hours.  
 $(AUTVP \div AUS VR ANNL FCTR) \div STD HOURS = \text{Hourly rate for packaged employee}$

### Calculating the Daily Rate

To calculate the daily rate, formula TER FM DAILY RATE:

- Determines if the employee is salary-packaged by checking for a value for rate code AUTVP.  
If there is no value for AUTVP, the system uses the employee's daily rate.
- Divides AUTVP by the annualized factor for the daily frequency specified on the Additional Info - AUS page in the pay group component.  
 $AUTVP \div AUS DY FACTOR = \text{Daily rate for packaged employee}$

**Note**

The system uses the system element DAILY RT as the daily rate for non-packaged employees. The daily rate is currently based on weekly rate ÷ 5. To calculate the daily rate differently, revise this formula.

## Resolution of Termination Earnings

This section discusses each of the earning elements in the Termination section and shows how they are resolved.

### Calculating Annual Leave Marginal Tax and Lump Sum A—Hours

The calculation rule for both AL MARGINAL and AL LUMP A is Unit × Rate, where:

Unit = TER FM AL BAL HRS

Rate = TER FM HOURLY RATE

The unit formula sums accumulators ANN ENTHRS\_BAL and ANN ENTHPH\_BAL.

Generation controls attached to each earning determine which of the two earnings to use to pay the hours.

For Annual Leave Marginal (hours), generation control TER GC TERM NORMAL uses TER FM NORM TERM to determine if the employee's status is Retired with Pay, Retired, Terminated, or Terminated with Pay. If it is and the action reason *is not* Staff Reduction, Early Retirement or Partial or Total Disability, then the system pays the hours value as AL MARGINAL.

For Lump Sum A, generation control TER GC TERM REDUN uses TER FM REDUN TERM to determine if the employee's status is Retired with Pay, Retired, Terminated, or Terminated with Pay. If it is and the action reason *is* Staff Reduction, Early Retirement, or Partial or Total Disability, then the system pays the hours value as AL LUMP A.

**Note**

The system does not provide for annual leave accrued prior to 1993, so the payout for annual leave on resignation, retirement, or dismissal is all to AL MARGINAL and is taxed at the marginal rate.

### Calculating Annual Leave Marginal Tax and Lump Sum A—Days

The calculation rule for both AL MARGIN DY and AL LUMPA DY is Unit × Rate, where:

Unit = TER FM AL BAL DYS

Rate = TER FM DAILY RATE

The unit formula sums accumulators ANN ENTDYS\_BAL and ANN PRODYS\_BAL.

The same two generation controls used with AL MARGINAL and AL LUMP A - Hours are attached to these two earnings, respectively. They do the same job, but this time the system pays the days value to either AL MARGIN DY or AL LUMPA DY.

### Related Topics

- [Calculating Annual Leave Marginal Tax and Lump Sum A—Hours](#)

The calculation rule for both AL MARGINAL and AL LUMP A is  $\text{Unit} \times \text{Rate}$ , where:

## Calculating Annual Leave Loading Marginal Tax and Lump Sum A—Hours

The calculation rule for both LL MARGINAL and LL LUMP A is  $\text{Unit} \times \text{Rate} \times \text{Percent}$ , where:

Unit = TER FM LL BAL HRS

Rate = TER FM HOURLY RATE

Percent = 17.5

The unit formula sums accumulators ANN ENTPH\_BAL and ANN ENTHRS\_BAL.

The same two generation controls used with AL MARGINAL and AL LUMP A are attached to these two earnings, respectively. They do the same job, but this time the system pays the hours value to either LL MARGIN or LL LUMP A.

## Calculating Annual Leave Loading Marginal Tax and Lump Sum A—Days

The calculation rule for both LL MARGIN DY and LL LUMPA DY is  $\text{Unit} \times \text{Rate} \times \%$ , where:

Unit = TER FM LL BAL DYS

Rate = TER FM DAILY RATE

% = 17.5

The unit formula is accumulator ANN ENTDYS\_BAL.

The same two generation controls used with AL MARGINAL and AL LUMP A are attached to these two earnings, respectively. They do the same job, but this the system time pays the days value to either LL MARGIN DY or LL LUMPA DY.

## Calculating Long Service Leave—Marginal Tax and Lump Sums A and B

Long service leave (LSL) payment calculations are affected by legislation that requires different tax rates to apply to the different periods during which the employee accrued the leave. We supply three LSL earnings: LSL MARGINAL, LSL LUMP A, and LSL LUMP B.

To calculate these earnings, you use the PeopleSoft-maintained formula TER FM LSL CALC. This formula is invoked by the formula TER FM PRE PROCESS, which is the first element in the Termination section. As soon as the Termination section's conditional formula TER FM TERM CHECK returns *True*, TER FM PRE PROCESS is invoked, which in turn invokes TER FM LSL CALC.

### Note

TER FM PRE PROCESS also invokes TER FM LSL PRE90, which is used to calculate LSL payments that are exempt from State Payroll Tax in NSW.

The formula first determines if the termination was for redundancy, early retirement, or partial or total disability (referred to as *Redundancy* in the following table).

Formula TER FM LSL CALC returns values for variables TER VR LS LUMPA, TER VR LS LUMPB and, if the termination was not redundancy, TER VR LS MARGINAL. These three variables are the units in the Unit × Rate calculation rules for the three LSL earnings. (The rate for all three earnings is TER FM DAILY RATE.)

This table shows how LSL may be paid according to the Action Reason of the termination:

Action/Reason for Termination	Payment Options
Termination Is Redundancy	<ul style="list-style-type: none"> <li>Lump Sum A only</li> <li>Lump Sum B only</li> <li>Lump Sum A and B</li> </ul>
Termination Is Not Redundancy	<ul style="list-style-type: none"> <li>Lump Sum A only</li> <li>Lump Sum B only</li> <li>Marginal only</li> <li>Lump Sum A and B</li> <li>Lump Sum A and B and Marginal</li> </ul>

Formula TER FM LSL CALC then uses other formulas that in turn use durations and system-generated accumulators based on the absence entitlements and take elements setup.

#### **Note**

TER FM LSL CALC uses formulas that in turn use system-generated accumulators, the current members of which are customary data. If you create new absence entitlement or take elements, you must adjust the formulas to use the accumulators that the system generates for those elements. You may have to adjust the following formulas: TER FM LSL TKES, TER FM LSTKE PST78, TER FM LSTKE PST93, and TER FM LSL BAL. The first three of those four formulas use variables of which you need to set the values. They are, respectively: TER VR LSTKW TOTAL or TER VR LSTKM TOTAL, TER VR LSTKW PST78 or TER VR LSTKM PST78, and TER VR LSTKW PST93 or TER VR LSTKM PST93, depending on the frequency of the take (weekly or monthly). In the formulas and variables tables in these topics, these elements appear in bold to indicate that you may need to adjust them.

## Calculating Lump Sum D

Lump Sum D payments, which are not taxed, are for redundancy and approved early retirement payments, but they have a limit. Whatever you pay over that limit is paid as a Lump Sum C employment termination payment (ETP), which may or may not be taxed. The resolution of Lump Sum C payments depends on the prior resolution of Lump Sum D.

The calculation rule for TERM LUMP D earning is Amount, where the amount is formula TERM FM LUMP D.

This is how the formula resolves:

1. It first uses Australian Tax Office (ATO)-supplied, PeopleSoft-maintained, variable values, and a duration that determines an employee's complete years of service to arrive at a figure—called the *calculated amount* in this topic.

The calculated amount is the limit that can be paid as Lump Sum D. The variables are TER VR LUMPD YRLY (yearly amount) and TER VR LUMPD INIT (initial amount), and the duration is TER DR TOTAL DAYS. The formula multiplies the yearly amount by the years of service, then adds the initial amount. This is the calculated amount or limit.

2. The formula then compares the calculated amount with the balance of accumulator TER AC RED/AER (Redundancy/Approved Early Retirement).

#### ① Note

The members of accumulator TER AC RED/AER are only ever REDUNDANCY (which is supplied) or [EARLY RETIREMENT] (which is not supplied). Both of these earnings are also members of accumulator TER AC ETP. The redundancy and early retirement earnings are not paid as such; they do not add to accumulator AUS GROSS. They exist so that you can enter their amounts as positive input and add to accumulators. The actual payment of redundancy or retirement amounts is as earning TERM LUMP D or a combination of TERM LUMP D and ETPTAX/ETP NON TAX.

Based on the results of the formula calculation, one of the following events occurs:

- If the calculated amount is greater than the accumulator amount, the payments do not exceed the limit and the full accumulator amount becomes the Lump Sum D payment.
- If the calculated amount is less than the accumulator amount, the payments exceed the limit, so only the calculated amount (the limit) becomes the Lump Sum D payment.

The balance becomes the basis of ETP calculations.

The balance becomes ETP (taxed or nontaxed—to be calculated) because the redundancy and retirement amounts also add to TER AC ETP, and whatever is paid as Lump Sum D by earning TERM LUMP D subtracts from TER AC ETP. If the redundancy and retirement accumulator was less than the calculated amount, and was therefore paid as Lump Sum D in full, then the balance of redundancy and retirement in the ETP accumulator is nil.

$RED/RET = TERM LUMP D$  so

$RED/RET - TERM LUMP D = Nil$

If the redundancy and retirement accumulator was more than the calculated amount, only the calculated amount would be Lump Sum D, so there would be a positive balance of redundancy and retirement payment in the ETP accumulator.

$RED/RET > TERM LUMP D$  so

$RED/RET - TERM LUMP D = +ve Bal of RED/RET$

## Calculating Genuine Redundancy and Early Retirement Payments for Employees Over 65

From 1 July 2019, employees who would otherwise meet the basic requirements to qualify for a genuine redundancy or an early retirement scheme will have changed age conditions. To work out if the employee can access the tax-free limit based on the employee's years of service, the aged based requirement of 65 years has been replaced with 'Pension Age'.

Use the bracket AUS BR PENSION AGE to pick the pension age based on the birth date of the employee.

Bracket Name page when AUS BR PENSION AGE is selected. Use the Bracket Name page (GP\_PIN) to define elements's basic parameters.

Bracket Name | Lookup Rules | Search Keys/Return Columns | Data

\*Name: AUS BR PENSION AGE  
 \*Description: Pension Age  
 \*Definition As Of Date: Calendar Period End Date

Element Type: Bracket  
 \*Field Format: Decimal  
 Element Nbr: 82860  Always Recalculate

**Element Use**

\*Owner: PS Delivered / Not Maintained  
 \*Class: Statutory  
 \*Used By: Specific Country  
 Country: AUS Australia  
 Industry/Region:   
 Category:

**Override Levels**

Pay Entity  Via Elements  
 Pay Group  Element Definition  
 Payee  Positive Input  
 Calendar

**Results**

Store  
 Store if Zero

**Resolution Parameters**

This element type does not require additional resolution parameters.

**Version Information**

Last Updated: 08/14/20 4:33:07.223366AM  
 Last Updated By: PPLSOFT  
 User Version:   
 Version: P\_9.20.30631917

[Custom Fields](#) [Comments](#)

Lookup Rules Page when AUS BR PENSION AGE is selected. Here, the lookup rules for a bracket is defined.

Bracket Name | **Lookup Rules** | Search Keys/Return Columns | Data

Element Name: AUS BR PENSION AGE Pension Age | Owner: PS Non-Mnt

**Definition** | 1 of 1 | View All

\*Effective Date: 07/01/2019 | \*Status: Active

**Lookup Rules**

**Error Processing Options**

Generate Error  
 Continue Process

**Outside Table Limits**

Use First Limit if Under  
 Use Last Limit if Over  
 Use Lowest / Highest Option

Interpolation Method: Use Next Higher  
 Rounding Rule Element:

Version: P\_9.20.30631917

Search Keys/Return Columns Page when AUS BR PENSION AGE is selected. Use this page to identify the search keys and the return columns for the bracket.

Bracket Name | Lookup Rules | **Search Keys/Return Columns** | Data

Element Name AUS BR PENSION AGE Pension Age Owner PS Non-Mnt

Definition 1 of 1 | View All

Effective Date 07/01/2019 Status Active

**Search Columns**

*Search Key 1 Type	SystemElem	*Element Name - Key 1	BIRTHDATE
Search Key 2 Type		Element Name - Key 2	
Search Key 3 Type		Element Name - Key 3	
Search Key 4 Type		Element Name - Key 4	
Search Key 5 Type		Element Name - Key 5	

**Return Columns**

Return Entry Type 1	Bracket	Element Name - Value 1	AUS BR PENSION AGE
Return Entry Type 2		Element Name - Value 2	
Return Entry Type 3		Element Name - Value 3	
Return Entry Type 4		Element Name - Value 4	
Return Entry Type 5		Element Name - Value 5	
Return Entry Type 6		Element Name - Value 6	
Return Entry Type 7		Element Name - Value 7	
Return Entry Type 8		Element Name - Value 8	

Data Page when AUS BR PENSION AGE is selected. Here, the lookup values are entered.

Bracket Name | Lookup Rules | Search Keys/Return Columns | **Data**

Element Name AUS BR PENSION AGE Pension Age Owner PS Non-Mnt

Definition 1 of 1 | View All

Effective Date 07/01/2019 Status Active

**Bracket Search Keys and Return Column Values**

Search Key	Return Column		
BIRTHDATE	AUS BR PENSION AGE		
07/01/1952	65.000000	+	-
12/31/1953	65.600000	+	-
06/30/1955	66.000000	+	-
12/31/1956	66.600000	+	-
01/01/1957	67.000000	+	-

For more information on Bracket Elements, see PeopleSoft Global Payroll: Defining Bracket Elements.

Once the pension age is identified using the bracket element, the duration of the employee from birth date till termination date (to compare with the pension age for identifying genuine redundancy or early retirement) is calculated using the Duration element: **TER DR BIRTH TERM**.

Definition Name Page when TER DR BIRTH TERM is selected.

Duration Name
Definition

\*Name

\*Description

\*Definition As Of Date

Element Type

\*Field Format

Element Nbr   Always Recalculate

**Element Use**

\*Owner

\*Class

\*Used By

Country

Industry/Region

Category

**Override Levels**

Pay Entity  Via Elements

Pay Group  Element Definition

Payee  Positive Input

Calendar

**Resolution Parameters**

This element type does not require additional resolution parameters.

**Version Information**

Last Updated

Last Updated By

User Version

Version

[Custom Fields](#)
[Comments](#)

Definition Page when TER DR BIRTH TERM is selected.

Duration Name	Definition								
Element Name	TER DR BIRTH TERM      Days from Birth to Term      Owner PS Non-Mnt								
<div style="border: 1px solid #ccc; padding: 5px;"> <div style="display: flex; justify-content: space-between; align-items: center;"> <span>Definition</span> <span>1 of 1</span> <span>View All</span> </div> <div style="margin-top: 10px;"> <p>Effective Date <input type="text" value="07/01/2019"/> *Status <input type="text" value="Active"/> + -</p> <p><b>Define Input Parameters</b></p> <table border="1" style="width: 100%; border-collapse: collapse;"> <tr> <td>*Date From Type</td> <td><input type="text" value="SystemElem"/></td> <td>*Date From</td> <td><input type="text" value="BIRTHDATE"/></td> </tr> <tr> <td>*Date To Type</td> <td><input type="text" value="SystemElem"/></td> <td>*Date To</td> <td><input type="text" value="TERMINATION DT"/></td> </tr> </table> <p><b>Define Return Value</b></p> <p>*Return Duration in <input type="text" value="Years"/></p> <p><input checked="" type="checkbox"/> Return Duration in Decimals</p> <p>Round months up from N days <input type="checkbox"/></p> <p>Round years up from N months <input type="checkbox"/></p> <p style="text-align: center;">Version P_9.20.30631917</p> </div> </div>		*Date From Type	<input type="text" value="SystemElem"/>	*Date From	<input type="text" value="BIRTHDATE"/>	*Date To Type	<input type="text" value="SystemElem"/>	*Date To	<input type="text" value="TERMINATION DT"/>
*Date From Type	<input type="text" value="SystemElem"/>	*Date From	<input type="text" value="BIRTHDATE"/>						
*Date To Type	<input type="text" value="SystemElem"/>	*Date To	<input type="text" value="TERMINATION DT"/>						

For more information of Duration Elements, see PeopleSoft Global Payroll: Defining Duration Elements.

Once, pension age and duration are identified, the redundancy and early retirement payments are calculated using the formula TERM FM LUMP D. For more information, see [Calculating Lump Sum D](#).

## Calculating Lump Sum C-Employment Termination Payment

ETP payments may or may not be taxed.

The system has to determine which part of the ETP earning is taxable and which part isn't.

Payments such as payment in lieu (of notice), ex gratia, invalidity, and, sometimes, the balance of redundancy and retirement payments are included in the ETP payments.

### Note

Earnings for payment in lieu (of notice), ex gratia, and invalidity are, like redundancy and retirement earnings, not resolved and paid as such; the amounts that you enter for them as positive input do not add to accumulator AUS GROSS. They do, however, add to accumulator TER AC ETP, and formulas use that accumulator to determine if the payments are to be ETP-taxed or ETP-nontaxed. Invalidity payments have additional processing.

ETPs are categorized into two: Excluded ETP and Non Excluded ETP.

**Excluded ETP**

The accumulator for Excluded ETP is TER AC ETP LBP. The delivered accumulator is customary in nature. ETP ER LBP is an earning element created to facilitate contributions to TER AC ETP LBP. You can provide positive input in ETP ER LBP for earnings contributing to the LBP category and calculate the values. You can also create multiple member elements for the accumulator for customized earnings.

**Calculating Taxable Excluded ETP**

In Excluded ETP, the earnings from Pre83 (ETP NONTAX) are non taxable and tax is calculated only from the Post83 earnings (ETP TAX). The Lump C tax (LUMP C TAX) is calculated from the Post83 earnings.

**Non Excluded ETP**

The accumulator for Non Excluded ETP payments is TER AC ETP WIC. ETP ER WIC is an earning element created to facilitate contributions to TER AC ETP WIC. You can provide positive input in ETP ER WIC for earnings contributing to the WIC category and calculate the values. Like the accumulator for Excluded ETP, for this accumulator also you can create member elements for customized earnings.

**Calculating Taxable Non Excluded ETP**

In Non Excluded ETP, the Pre83 earnings (ETP NTAX WIC) are non taxable and tax is calculated only from the Post83 earnings (ETP TAX WIC). The Whole of Income tax (ETP WIC TAX) is calculated from the Post83 earnings of the Non Excluded ETPs.

## Calculating Invalidity and Invalidity Post 94 Payments

The calculation rule for earning INVALIDITY is Amount, and the amount is Payee Level. It is another earning for which you enter the value by positive input and that does not add to AUS gross. It does, however, add to the accumulator TER AC ETP. It also adds to its own accumulator TER AC INVALIDITY.

The calculation rule for earning INV POST 94 is Amount, and the amount is formula TER FM INV POST94.

**Note**

Despite its name, the calculation of post 94 invalidity earning does not involve any durations based on the year 1994.

The formula multiplies the amount of accumulator TER AC INVALIDITY (added to by your positive input) by duration TER DR TERM RETIRE, which calculates the days from the employee's termination date to his or her normal retirement date. It then divides by duration TER DR HIRE RETIRE, which calculates the days from the employee's hire or rehire date to normal retirement date.

Accumulator amount × days from term to norm retirement / days from hire (or rehire) to norm retirement = TER FM INV POST94 = earning INV POST 94

The start date for duration TER DR HIRE RETIRE is formula TER FM DUR START, which returns the rehire date if the hire date is earlier than the rehire date.

Because the positive input for earning INVALIDITY adds to TER AC ETP, and earning INV POST 94 subtracts from it, the balance of INVALIDITY is processed as any other ETP payment.

**Related Topics**

- [Calculating Lump Sum C-Employment Termination Payment](#)  
ETP payments may or may not be taxed.

## Entering Final Hours

For employees who accrue annual leave-in hours based on hours worked, you must enter their final hours in the variable TER VR FINAL HRS on the Supporting Elements Override page (select **Global Payroll & Absence Mgmt**, and then **Payee Data**, and then **Create Overrides**, and then **Supporting Elements**) when they are terminated. Those hours grant the correct accrual during the resolution of section ABS ENTHPHG in the GEN ABSENCE process list for payment by the AUS PAYROLL process. The section resolves only if its conditional formula returns that the employee has been terminated. Employees who accrue hours based on hours and who are not terminated have their accrual processed through the HRLY ACCRUED process list, which is run after AUS PAYROLL when the hours on which to base the accrual are known.

# Reporting Workplace Gender Equality

## Understanding the Workplace Gender Equality Report

The Workplace Gender Equality Act 2012 requires all non-public sector employers to report to the Workplace Gender Equality Agency (WGEA) annually. The employers must complete and submit online a workplace profile and the reporting questionnaire covering standardized reporting matters under a specific number of gender equality indicators. The workplace profile should show the composition of their workforce by gender, employment status, standardized occupational categories and remuneration data, and for managers, their reporting level to the CEO. Two options are available for reporting: Unit level data and Aggregate data.

PeopleSoft HCM supports the Aggregate data format, in which you have to report workplace profile details for managers and non-managers separately. You can download a system-generated Excel template from the WGEA online portal to enter the workplace profile data. This Excel template contains two sheets: one for managers and one for non-managers. While downloading the Excel template, you have to indicate how many reporting levels are present in your organization until the CEO. The template thus generated will reflect those precise reporting levels. PeopleSoft HCM does not generate the template as such, but instead, will support you to draw all the necessary details. The data so drawn can be used to fill the Excel spreadsheet. Once populated, that spreadsheet can be uploaded to the online portal.

## Setting Up WGEA Remuneration Details

To set up WGEA Remuneration Details, use the WGEA Remuneration Details AUS (GPAU\_WGEA\_SECTN) component.

The remuneration details are calculated from the Global Payroll earnings and deductions paid in the reporting period. The WGEA Remuneration Details AUS page is used to configure the earnings and deductions for reporting Annualized Average Full Time Equivalent Base Salary and Total Remunerations.

In PeopleSoft HCM, the remuneration details are categorized under six sections:

- Base salary
- Bonus
- Discretionary pay
- Overtime
- Other remuneration
- Superannuation

You can also add new pay components for earnings or deduction to any of the existing sections.

This section discusses how to set up the WGEA remuneration details.

## Pages Used to Set Up WGEA Remuneration Details

Page Name	Definition Name	Usage
<a href="#">WGEA Remuneration Details AUS Page</a>	GPAU_WGEA_SECTN	Configure the remuneration details of the employees for workplace gender equality reporting.

## WGEA Remuneration Details AUS Page

Use the WGEA Remuneration Details AUS page (GPAU\_WGEA\_SECTN) to configure the remuneration details of the employees for workplace gender equality reporting.

Navigation:

**Set Up HCM**, and then **Product Related**, and then **Global Payroll and Absence Management**, and then **Reports WGEA Remuneration Details AUS**

This example illustrates the fields and controls on the WGEA Remuneration Details AUS page (Base\_Sal). You can find definitions for the fields and controls later on this page.

### WGEA Remuneration Details AUS

Section ID BASE\_SAL

Section Description Find | View All First 1 of 1 Last

\*Effective Date  + -

\*Status

\*Description

Short Desc

Pay Components		Personalize   Find   View All   1-5 of 5 Last	
Entry Type	*Element Name	Description	
1 <input type="text" value="Earnings"/>	<input type="text" value="REGPAY HRLY"/>	Regular hourly payment	<span style="float: right;">+</span> <span style="float: right;">-</span>
2 <input type="text" value="Earnings"/>	<input type="text" value="REGPAY STDHR"/>	Regular standard hourly pay	<span style="float: right;">+</span> <span style="float: right;">-</span>
3 <input type="text" value="Earnings"/>	<input type="text" value="RETRO12MTH"/>	Retro - Previous 12 Months	<span style="float: right;">+</span> <span style="float: right;">-</span>
4 <input type="text" value="Earnings"/>	<input type="text" value="RETRO CY"/>	Retro pay for the current year	<span style="float: right;">+</span> <span style="float: right;">-</span>
5 <input type="text" value="Earnings"/>	<input type="text" value="RETRO PY"/>	Retro Pay for Prior Year	<span style="float: right;">+</span> <span style="float: right;">-</span>

This example illustrates the fields and controls on the WGEA Remuneration Details AUS page (Bonus). You can find definitions for the fields and controls later on this page.

### WGEA Remuneration Details AUS

Section ID **BONUS**

Section Description Find | View All | First 1 of 1 Last

\*Effective Date

\*Status

\*Description

Short Desc

**Pay Components** Personalize | Find | View All | 1-5 of 5 Last

	Entry Type	*Element Name	Description		
1	<input type="text" value="Earnings"/> <input type="button" value="v"/>	<input type="text" value="PRDBON"/> <input type="button" value="Q"/>	Product Bonus	<input type="button" value="+"/>	<input type="button" value="-"/>
2	<input type="text" value="Earnings"/> <input type="button" value="v"/>	<input type="text" value="BONUS GRS UP"/> <input type="button" value="Q"/>	Gross up amount	<input type="button" value="+"/>	<input type="button" value="-"/>
3	<input type="text" value="Earnings"/> <input type="button" value="v"/>	<input type="text" value="BONUS NET"/> <input type="button" value="Q"/>	Bonus gross up	<input type="button" value="+"/>	<input type="button" value="-"/>
4	<input type="text" value="Earnings"/> <input type="button" value="v"/>	<input type="text" value="BONUS"/> <input type="button" value="Q"/>	Bonus	<input type="button" value="+"/>	<input type="button" value="-"/>
5	<input type="text" value="Earnings"/> <input type="button" value="v"/>	<input type="text" value="BONUS QTRLY"/> <input type="button" value="Q"/>	Quarterly Bonus	<input type="button" value="+"/>	<input type="button" value="-"/>

This example illustrates the fields and controls on the WGEA Remuneration Details AUS page (Discretionary Pay). You can find definitions for the fields and controls later on this page.

### WGEA Remuneration Details AUS

Section ID **DP**

Section Description Find | View All | First 1 of 1 Last

\*Effective Date

\*Status

\*Description

Short Desc

**Pay Components** Personalize | Find | View All | 1 of 1 Last

	Entry Type	*Element Name	Description		
1	<input type="text" value="Earnings"/> <input type="button" value="v"/>	<input type="text" value="TRAINADV"/> <input type="button" value="Q"/>	Train fare advance	<input type="button" value="+"/>	<input type="button" value="-"/>

This example illustrates the fields and controls on the WGEA Remuneration Details AUS page (Overtime). You can find definitions for the fields and controls later on this page.

## WGEA Remuneration Details AUS

Section ID OT

**Section Description** Find | View All First 1 of 1 Last

\*Effective Date

\*Status

\*Description

Short Desc

Pay Components		Personalize   Find   View All   <input type="button" value="🔍"/> <input type="button" value="📄"/>		1-4 of 4 Last	
	Entry Type	*Element Name	Description		
1	<input type="text" value="Earnings"/> ▼	<input type="text" value="OT1.5"/> 🔍	Overtime 1.5	<input type="button" value="+"/>	<input type="button" value="-"/>
2	<input type="text" value="Earnings"/> ▼	<input type="text" value="OT2.0"/> 🔍	Overtime 2.0	<input type="button" value="+"/>	<input type="button" value="-"/>
3	<input type="text" value="Earnings"/> ▼	<input type="text" value="OT2.5"/> 🔍	Overtime 2.5	<input type="button" value="+"/>	<input type="button" value="-"/>
4	<input type="text" value="Earnings"/> ▼	<input type="text" value="OT3.0"/> 🔍	Overtime 3.0	<input type="button" value="+"/>	<input type="button" value="-"/>

This example illustrates the fields and controls on the WGEA Remuneration Details AUS page (Other Remuneration). You can find definitions for the fields and controls later on this page.

## WGEA Remuneration Details AUS

Section ID OTHERS

Section Description Find | View All First 1 of 1 Last

\*Effective Date

\*Status

\*Description

Short Desc

Pay Components			Personalize   Find   View All   <input type="button" value="A"/> <input type="button" value="B"/>		1-15 of 15 Last	
Entry Type	*Element Name	Description				
1 Earnings	SHFAM	Shift Loading Morning	<input type="button" value="+"/>	<input type="button" value="-"/>		
2 Earnings	SHFPM	Shift Loading Afternoon	<input type="button" value="+"/>	<input type="button" value="-"/>		
3 Earnings	SHFNT1	Shift Night Loading	<input type="button" value="+"/>	<input type="button" value="-"/>		
4 Earnings	FAD	First Aid Allowance	<input type="button" value="+"/>	<input type="button" value="-"/>		
5 Earnings	SCK	Sick Leave	<input type="button" value="+"/>	<input type="button" value="-"/>		
6 Earnings	OTHLV	Other Leave	<input type="button" value="+"/>	<input type="button" value="-"/>		
7 Earnings	LULD	Leave Loading	<input type="button" value="+"/>	<input type="button" value="-"/>		
8 Earnings	CAR	Car Allowance	<input type="button" value="+"/>	<input type="button" value="-"/>		
9 Earnings	PHONE	Phone allowance	<input type="button" value="+"/>	<input type="button" value="-"/>		
10 Earnings	ONCALL	On Call allowance	<input type="button" value="+"/>	<input type="button" value="-"/>		
11 Earnings	SHFNT2	Shift loading night	<input type="button" value="+"/>	<input type="button" value="-"/>		
12 Earnings	STRESS	Stress allowance	<input type="button" value="+"/>	<input type="button" value="-"/>		
13 Earnings	ANNRA	Annual leave rolling average	<input type="button" value="+"/>	<input type="button" value="-"/>		
14 Earnings	ANN	Annual leave	<input type="button" value="+"/>	<input type="button" value="-"/>		
15 Earnings	PUB	Public holiday	<input type="button" value="+"/>	<input type="button" value="-"/>		

This example illustrates the fields and controls on the WGEA Remuneration Details AUS page (Superannuation). You can find definitions for the fields and controls later on this page.

## WGEA Remuneration Details AUS

Section ID SA

Section Description
Find | View All
First 1 of 1 Last

\*Effective Date

\*Status

\*Description

Short Desc

Pay Components
Personalize | Find | View All
1-4 of 4 Last

Entry ID	Entry Type	*Element Name	Description		
1	<input type="text" value="Deduction"/>	<input type="text" value="ER ADDLSPR"/>	Employer Additional Super	<input type="text" value=""/>	<input type="text" value=""/>
2	<input type="text" value="Deduction"/>	<input type="text" value="EE SSSPR"/>	Employee Salary Sacrifice Super	<input type="text" value=""/>	<input type="text" value=""/>
3	<input type="text" value="Deduction"/>	<input type="text" value="ER MATCHSPR"/>	Employer Matching Super	<input type="text" value=""/>	<input type="text" value=""/>
4	<input type="text" value="Deduction"/>	<input type="text" value="EE SUPER"/>	Employee Super	<input type="text" value=""/>	<input type="text" value=""/>

Field or Control	Description
<b>Section ID</b>	Displays the category of the remuneration details.
<b>Eff Date</b>	Enter the effective date of the Earnings/Deduction section.
<b>Status</b>	Enter the status of the Earnings/Deduction section. There are two options: Active and Inactive.
<b>Description/Short Desc</b>	Enter the description/short description for the Earnings/Deduction section.
<b>Entry Type</b>	Select the Pay Component. It can be either Earnings or Deductions.
<b>Element Name</b>	Select the Element name of the Pay Component.
<b>Description</b>	This is a display only field which has the description of the selected Pay Component.

### Back Payments

Back payments for a previous tax year (this period may fall within the same reporting year or a previous reporting year) are also included in the WGEA report. These are reported under the appropriate sections in the WGEA Remuneration Details AUS page. The elements used to report back payments are: Retro CY (retro payment for the current year), Retro PY (retro payment for the prior year), and RETRO12thMTH (retro payment accrued for any pay period that is 12 months prior to the current pay period).

### Related Topics

- PeopleSoft Human Resources Meet Regulatory Requirements: Running the Workplace Gender Equality Report

# Managing End of Year Reporting

## Setting Earnings and Deduction Categories

The earnings and deductions categories determine where earnings and deductions appear on the payment summary.

You categorize earnings and deductions that appear on the payment summary by assigning a character value to the variable EOY VR CATEGORY on the Supporting Element Override page for a selected earnings or deduction.

## Earnings and Deductions Categories and Values

The following table lists the character values for the EOY VR CATEGORY on the Supporting Element Override page for a selected earnings or deduction:

<b>Earnings and Deduction Category</b>	<b>EOY VR CATEGORY Value</b>
Allowances	A
CDEP (Community Development Employment Project)	C
Reportable FBT	F
Gross Pay	G
Exempt Foreign Employment Income	O
Total Tax Withheld	T
Union Fees	U
Lump Sum A Payments	LA
Lump Sum B Payments	LB
Lump Sum D Payments	LD
Lump Sum E Payments	LE
ETP Pre 83 Payments	E1
ETP Post 83 Taxed Elements	E4
ETP Post 83 Untaxed Elements	E2
ETP Post 94 Invalidation Payments	E3
ETP Withheld Tax	ET
Pre-tax Deductions	PT
Reportable Salary Packaged Superannuation Components That Do Not Further Reduce From Gross	RS
Salary Sacrifice	SS
Charity Deduction	W
FOREIGN INCM	FG

Earnings and Deduction Category	EOY VR CATEGORY Value
FOREIGN TAX (Tax Paid in Foreign Country)	FT
PG TX FRGINC (AUS Tax w/h on Frgn Income)	FW
FRN FBT EARN (Foreign FBT earnings)	FE
FRN ER SUPER (Reportable Employer Super)	FS
ALLOWANCE (Foreign Allowance)	FA
FRGN LE TAX (Foreign Lump E tax)	FW
AL FR LUMP A — Foreign Employment Annual Leave Lump Sum A	FLA
AL FR LMPADY — Foreign Employment Annual Leave LUMP SumA- Days	FLA
LS FR LUMP A – Foreign Employment Earnings LSL- Lump Sum A	FLA

## Collecting FBT-Liable Earnings

The ATO requires that you report FBT-liable earnings when the gross-up value (of all FBT-liable earnings) exceeds a minimum figure. To have the system calculate the reportable fringe benefits amount for inclusion on the payment summary, you run a collect process.

This topic discusses ways to collect FBT-liable earnings.

### Summing Category F Earnings

Use the FBT Collection page (select **Global Payroll & Absence Mgmt**, and then **Year-End Processing**, and then **Collect FBT Earnings AUS**) to set the parameters to have the system sum the net amounts of all earnings categorized as *F* (variable EOY VR CATEGORY) and gross them up. This is the same run control page—GPAU\_RC\_FBT\_COLLEC—as used for Create Payment Summary. The difference is that this process uses the Application Engine program GPAU\_FBT\_COL and Create Payment Summary uses GPAU\_PSM\_CRE.

You need to enter the tax year and the population you are generating the data for. The population can be pay entity, pay group, or payee.

The **Update if Record Exists** check box relates to the record values that appear on the Reportable FBT Earnings page. If you select this check box and the record exists (either because of a manual entry only—status Entered—or because you have run the collect process previously—status Created), rerunning the process updates the calculated amount only. It does not change any manual entry.

The process is Application Engine process GPAU\_FBT\_COL.

#### Note

You need to set up your FBT percent and minimum reportable FBT-liable earnings in Salary Packaging before you can run this process.

## Page Used to View and Adjust FBT-Liable Earnings

Page Name	Definition Name	Usage
<a href="#">Rvw/Update Payee FBT Earns AUS Page</a>	GPAU_EE_FBT	View calculated amounts, add manual amounts, conditionally change the status, or view gross-up values. You view the calculated amounts after you have run the Collect Reportable FBT process.

### Related Topics

- PeopleSoft Human Resources Administer Salary Packaging: Setting Up and Viewing Salary Packaging Tax Options

## Rvw/Update Payee FBT Earns AUS Page

Use the Rvw/Update Payee FBT Earns AUS page (GPAU\_EE\_FBT) to view calculated amounts, add manual amounts, conditionally change the status, or view gross-up values. You view the calculated amounts after you have run the Collect Reportable FBT process.

Navigation:

**Global Payroll & Absence Mgmt**, and then **Year-End-Processing**, and then **Rvw/Update Payee FBT Earns AUS**

This example illustrates the fields and controls on the Rvw/Update Payee FBT Earns AUS page. You can find definitions for the fields and controls later on this page.

### Rvw/Update Payee FBT Earns AUS

Name Justin Whitford Empl ID KA0014

Pay Entity KAAUSBI AUSTRALIAN BUSINESS INSTITUTE Balance Group Nbr 000

Tax Year 2003 \*Status

FBT Details			
Manual FBT Amount	3,500.00	Gross Up	6,795.95
Collected FBT Amount	0.00	Gross Up	0.00
		Total FBT	6,795.95

DateTime Stamp 07/18/2004 11:16PM

Field or Control	Description
<b>Status</b>	<p>You can change the status from <i>Processed</i> to <i>Created</i> but only if the status of the Payment Summary process is still <i>Created</i> (not <i>Processed</i> or <i>Issued</i>). You change it to rerun the collect process to repopulate the <b>Collected FBT Amount</b> field. The statuses are:</p> <p><i>Entered</i>: The page has had a manual entry only.</p> <p><i>Created</i>: The Collect Reportable FBT has been run (even if the process didn't pick up any amount)</p> <p><i>Processed</i>: Payment summaries have been created and the FBT data included (if there was any).</p> <p><i>Issued</i>: Refers only to the Payment Summary processes.</p>
<b>Manual FBT Amount</b>	<p>This is for any manually calculated amounts. Any values entered here are not affected by rerunning the collect process, which updates only the <b>Collected FBT Amount</b> field. The system displays the gross-up value of the amount that you enter in the associated <b>Gross Up</b> field.</p>
<b>Collected FBT Amount</b>	<p>This is the result of the Collect Reportable FBT process (which may be 0.00). The system displays the gross-up value of the collected amount in the associated <b>Gross Up</b> field.</p>
<b>Total FBT Amount</b>	<p>This is the total of the gross-up amounts. If the amount exceeds the minimum FBT-liable earnings for payment summary reporting, it is reported on the employee's payment summary and included in the electronic file submission to the ATO.</p>
<b>Date Time Stamp</b>	<p>This is the date and time that the page (record) was last updated—manually or by the process.</p>

## Reporting FBT for Terminated Employees

An employee might terminate employment between the end of the FBT year and the end of the corresponding tax year. If, during that period—April 1 to June 30—that employee received reportable FBT-liable earnings over the reportable limit, you need to process two FBT collections and two payment summaries. The first is for the tax year in which the employee terminated employment. The second is solely to report the FBT-liable earnings that would normally have been reported on the payment summary for the next tax year. The system retrieves the FBT-liable earnings even though there is no tax balance record for that next tax year.

In this diagram, the position of PSM2 indicates the tax year to which the FBT belongs.

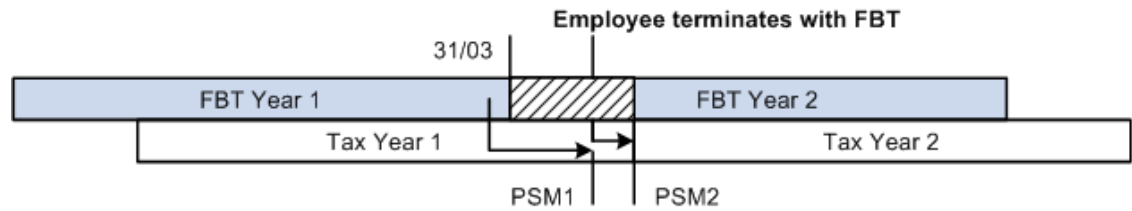

## Generating Payment Summary Data

When data preparation is complete, you can generate the payment summary data for each employee. You can view the data before printing payment summaries for issue to payees.

After you have generated the payment summary data, you must print the payment summaries before you can create the electronic file for the ATO.

This topic discusses ways to generate payment summary data.

### Note

The system only includes FBT in the payment summary if its gross-up value exceeds the PeopleSoft-maintained minimum amount. You can see the minimum amount on the FBT/GST Rate page.

## Pages Used to Generate/View Payment Summary Data

Page Name	Definition Name	Usage
Collect FBT Earns AUS Page	GPAU_RC_FBT_COLLEC	Enter the tax year and the payee population, which can be <i>Pay Entity</i> , <i>Pay Group</i> , or <i>Payee</i> .  There is an <b>Update if Record Exists</b> check box. If you have already run the process, (and the payment summary status Created), this process overwrites the stored values in the record.  The process is Application Engine process GPAU_FBT_COL.
Rvw/Update Payee FBT Earns AUS Page	GPAU_EE_FBT	View the results of running the Collect FBT Earns AUS report.
Create Pmnt Summary Data AUS Page	GPAU_RC_FBT_COLLEC	This process generates a payee's payment summary information. Enter the tax year and the payee population, which can be pay entity, pay group, or payee. The process is Application Engine process GPAU_PSM_CRE.

Page Name	Definition Name	Usage
<a href="#">Review Pmnt Summary Data AUS Page</a>	GPAU_EE_PSM	View the results of running the Create Payroll Summary process.
Payment Summary Exceptions AUS Page	GPAU_RC_PSM_EXCPT	This process generates the Payment Summary Exceptions report. This report is used to list discrepancies between YTD amounts and actual results per period. <b>Note:</b> You must validate and take appropriate actions regarding negative values before running the Payment Summary/ETP Certs AUS process.
Payment Summary Reconcile AUS Page	GPAU_RC_PSM_RECON	Generates the Payment Summary Reconciliation Report. It reconciles all of the amounts reported in the online payment summary panels. There are 3 separate sections, one for employees, one for contractors with ABN and one for contractors with no ABN, as well as the company totals.
Payment Summary/ETP Certs AUS Page	GPAU_RC_PSM_PRINT	Set the parameters to print payment summaries and/or ETP Certificates for payees or groups of payees.
<a href="#">Create Pmnt Summ Elec File AUS Page</a>	GPAU_RC_PSM_ELEC	Set the parameters for the generation of the electronic file to the ATO.
<a href="#">Review Foreign Pmnt Data AUS Page</a>	GPAU_EE_FRGN	View the results of running the Foreign Payment Data process.

## Review Pmnt Summary Data AUS Page

Use the Review Pmnt Summary Data AUS page (GPAU\_EE\_PSM) to view the results of running the Create Payroll Summary process.

Navigation:

**Global Payroll & Absence Mgmt**, and then **Year-End Processing**, and then **Review Pmnt Summary Data AUS**, and then **Review Pmnt Summary Data AUS**

This example illustrates the fields and controls on the Review Pmnt Summary Data AUS page. You can find definitions for the fields and controls later on this page.

## Review Pmnt Summary Data AUS

Name Jane Taylor

Empl ID KA0001

Pay Entity KAAUSBI AUSTRALIAN BUSINESS INSTITUTE

Balance Group Nbr 000

Tax Year 2013

Status Created

Payment Data				
Payment Period:	07/01/2012	To:	06/30/2013	<input type="checkbox"/> Amended
Tax Withheld:	1,526.00	Reportable FBT Earnings:	0.00	
Gross Payments:	8,333.34			
CDEP Salary and Wages:	0.00			
Other Income:	0.00			
Reportable Super Contributions:	0.00			
Allowances:	VARIOUS	710.96	Details	
Total Allowance:		710.96		
Lump Sum Payments: A:	0.00	B:	0.00	
	D:	0.00	E:	0.00
Union Fees:	Union Fees	19.00		
Total Union Fees:		19.00		
Workplace Giving:		0.00		

After running the Create Payment Summary Data process for the tax year and payee population that you select, you can view the results. The EOY VR CATEGORY Supporting Element Override value that you set for each earning and deduction dictates in which total their values are included. The display is by employee name and ID, pay entity, balance group ID, and tax year.

Field or Control	Description
<b>Payment Period</b>	For normal end-of-tax-year processing, this shows 01/07/YY - 1 to 30/06/YY. For terminated employees, it shows 01/07/YY - 1 to termination date. For hired employees, it shows hire date to 30/06/YY.
<b>Tax Withheld</b>	Total of all category T deductions.
<b>Gross Payments</b>	Total of all category G earnings.
<b>CDEP Salary and Wages</b>	Total of all category C earnings.
<b>Other Income</b>	Total of all category O earnings.

Field or Control	Description
<b>Reportable Super Contributions</b>	<p>Displays the Reportable Employer Super Contributions (RESC).</p> <p>The system provides two override values for the EOY VR CATEGORY:</p> <ul style="list-style-type: none"> <li>• PT captures only pre-tax deductions</li> <li>• RS captures the salary packaged superannuation components that must be reported under RESC, but should not further reduce from gross.</li> </ul>
<b>Allowances</b>	<p>Total of all category A earnings.</p> <p>If an employee has one or two allowances, then it is listed here. If there are more than two allowances, it will be listed as VARIOUS and the total of the allowances under this category will be displayed. A Details link is also displayed, which opens a window listing all the allowances.</p>
<b>Total Allowances</b>	Total of all allowances.
<b>Lump Sum Payments (A, B, D and E)</b>	All earnings of category LA, LB, LD, and LE, respectively.
<b>Type</b>	<p>Displays the type of Lump Sum A payment, based on the Action Reason of the termination specified in the Job Data pages. This field does not display a value when the employee has not received any Lump Sum A payments.</p> <p>The system displays the value <i>R</i> when the termination Action Reason is Elimination of Position (redundancy), Partial/Total Disability (invalidity), or Early Retirement. displays the value <i>T</i> for all other reasons.</p>
<b>Union Fees</b>	<p>All deductions of category U.</p> <p>If an employee has one or two types of deductions under Union Fees and Professional Association Fees, then it is listed here. If there are more than two deductions, it will be listed as VARIOUS and the total of the deductions under this category will be displayed. A Details link is also displayed, which opens a window listing all the deductions under Union Fees.</p>
<b>Workplace Giving</b>	<p>Total of all workplace giving.</p> <p>If the employer had made payments to more than one deductible gift recipient on behalf of the employee, then it will be listed as VARIOUS and the sum of the payments will be displayed. A Details link is also displayed, which opens a window listing all the payments made under Workplace Giving.</p>

**Note**

Lump Sum C earnings don't appear, because Lump Sum C ETPs are extracted and reported separately.

## Printing the Payment Summary

When all your data is correct, you can use the Payment Summary/ETP Certs page to print either or both of the two variations of the payment summary and any ETP certificates the system generated during the Create Payment Summary process.

If the payment summary has 'VARIOUS' listed against any of the items, an addendum is issued for each item, which details the payments made/amounts withheld during the year.

**Note**

After you have generated the payment summary data, you must print the payment summaries before you can create the electronic file for the ATO.

## Create Pmnt Summ Elec File AUS Page

Use the Create Pmnt Summ Elec File AUS page (GPAU\_RC\_PSM\_ELEC) to set the parameters for the generation of the electronic file to the ATO.

Navigation:

**Global Payroll & Absence Mgmt**, and then **Year-End-Processing**, and then **Create Pmnt Summ Elec File AUS**, and then **Create Pmnt Summ Elec File AUS**

**Note**

After you have generated the payment summary data, you must print the payment summaries before you can create the electronic file for the ATO.

This example illustrates the fields and controls on the Create Pmnt Summ Elec File AUS page. You can find definitions for the fields and controls later on this page.

### Create Pmnt Summ Elec File AUS

Run Control ID BEC
Report Manager
Process Monitor
Run

Language

**Parameters**

\*Tax Year 
 Amended

**Run Type**

Production
 Test

**Magnetic Media Type**

PAYG Payment Summary
 PAYG Withholding with No ABN

**Pay Entity List** Find | View All

Pay Entity 
First 1 of 1 Last

The ATO requires an electronic file containing all the data that the system has extracted for payment summaries and ETP certificates. You can create a single file for multiple pay entities. The ATO also requires two separate files: one for regular payees and one for contractors who do not have an ABN. The file contains software information, payer information such as ABN and contact details, and payee information such as the tax file number, gross payment, and withheld tax.

The file is created by Application Engine program GPAU\_PSM\_ELEC. This program uses data extracted by the Application Engine program that created the payment summary.

Before you remit payment summary information electronically to the ATO or distribute printed summaries to your payees, you can use the Payroll Summary Exceptions and Payment Summary Reconciliation reports to verify the data extracted by the Application Engine program.

#### Run Type

Field or Control	Description
<b>Production</b> or <b>Test</b>	Select <b>Test</b> when preparing a file to send to the ATO for validity testing. Ensure that a test submission can never be mistaken for production data.

#### Magnetic Media Type

Field or Control	Description
<b>PAYG Payment Summary</b>	Select to produce a file of data for regular payees.
<b>PAYG Withholding with No ABN</b>	Select to produce a file of data for contractor payees who do not have an ABN.

**Pay Entity List**

Field or Control	Description
Pay Entity	Select as many pay entities as you want to include in the file.

## Review Foreign Pmnt Data AUS Page

Use the Review Frgn Pmnt Data AUS page (GPAU\_EE\_FRGN) to report the data extracted by the GPAU\_PSM\_CRE process.

Navigation:

**Global Payroll & Absence Mgmt**, and then **Year-End Processing** , and then **Review Foreign Pmnt Data AUS**

## Using Self Service Reporting Framework

You can generate, view and download the Payment Summary report via the self service portal. Using the self service portal, administrators can define and configure the report, whereas the employees can view and download. The high level business process of the self service reporting framework is depicted in the image below.

This example illustrates the high level business process of self service reporting framework.

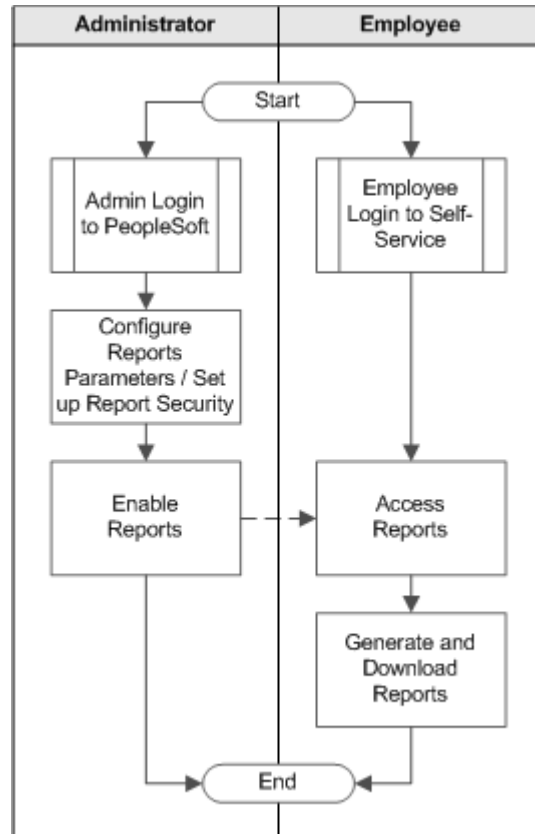

## How to define and generate the Payment Summary Report

The administrator follows the procedure to define and generate the Payment Summary Report.

1. Receive notification to include Payment Summary Report as part of Employee Self Service.
2. Obtain BI Publisher report object names for Payment Summary report
3. Create an appropriate Report Group, if it does not already exist and enable it.
4. Create an appropriate Report ID for the Payment Summary report and attach it to the respective Report Group.
5. Map the BI Publisher report object name to the Report ID.
6. Map a filter query and define the filter fields for the generation of Payment Summary report.
7. Define a security query to restrict the access of the report to only the required employees.

Some of the steps in the above procedure are detailed in the following sections.

### Creating a Report Group

The Administrator creates a Report Group to define a cluster of reports. Each report group is mapped to a country. The administrator creates a new Report Group for Australia by clicking the **Add a New Value** tab.

This example illustrates the fields and controls on the Group Setup page.

### Group Setup

Group ID	AUSTRALIA
Country	AUS      Australia
<b>Group Description</b>	
*Description	Australia Year-End Reports <input type="checkbox"/> Enabled
Short Desc	Australia
Sequence	10

To know more about creating a report group, see [Application Fundamentals: Group Setup Page](#).

### Enabling Self-Service Reports

To enable self service reporting, the administrator creates a Report ID via the **Enable Self-Service Report** page. To link the report to a report group, you need to map the **Report ID** to the **Group ID**. You can map multiple reports to a report group.

This example illustrates the fields and controls on the Enable Self-Service Reports page.

## Enable Self-Service Reports

Report ID GPAUFRN  
Country AUS Australia

**Report Parameters** Find | View All First 1 of 1 Last

\*Effective Date 07/01/2012

Effective Status Active

\*Group ID AUSTRALIA Australia Year-End Reports

Sequence Number 20

\*Report Title Payment Summary - Foreign Employment

\*Tree Descr Payment Summary - FRN

Security Query

**Report Instruction Text**

Message Set Number 17200 Message Number 1005

**Digital Security**

Digital Signature  Password Protect

\*Package Name GPAU\_SS\_RPT

\*Path :

\*Class ID GenPassword

### Note

The **Digital Security** group box is currently not applicable to Global Payroll for Australia.

To know more about enabling self service reports, see Application Fundamentals: Enable Self-Service Reports Page.

### Configuring Self Service Reports

The administrator maps the existing reports developed in BI Publisher to the Report IDs. For this, the report to be mapped to a Report ID must be available in BI Publisher. The two key items required from BI Publisher are:

- *Report Name:* All reports created by the report developer using BI Publisher has a unique identifier and key to map Report IDs and Reports. These reports have multiple report templates on to which data is populated. These report templates are effective-dated.
- *Query Name:* Every report runs SQL queries that retrieve data from the database. There are multiple parameters passed to these queries to retrieve the right set of data required to be displayed in the report. These parameters are either dynamically fetched by system or are inputs provided by employee on the self-service portal. These queries are named.

Reports created using BI Publisher are mapped to Report IDs. The administrator can search and select from a list of existing Report IDs and define the parameters.

This example illustrates the fields and controls on the Configure Self-Service Reports page.

### Configure Self-Service Reports

Report ID GPAUFRN      Payment Summary - Foreign Employment  
Country AUS      Australia

**BI Publisher Details**

\*Report Name  Foreign Employee PSM Report  
 \*Query Name  Payment Summary - FRN  
 Template Control Field

Report Templates			Personalize   Find   View All	First  1 of 1  Last
Template ID	Language Code	Default Template		
1 GPAU_FRN_RPT_1	ENG	<input checked="" type="checkbox"/>		

To know more about configuring self service reports, see Application Fundamentals: Configure Self-Service Reports Page.

### Defining Report Filters

Report Filters are parameters that are passed to an SQL query to fetch data to populate the report template. These parameters can either be dynamically passed or can be taken as an input from an employee through the self-service portal. The parameters that are passed as input by the employee are defined using the Define Report Filters page. The administrator searches and selects from a list of existing Report IDs and define the report filter parameters

This example illustrates the fields and controls on the Define Report Filters page.

### Define Report Filters

Report ID GPAUFRN      Payment Summary - Foreign Employment  
Country AUS      Australia

**Filter Fields**      Personalize | Find | View All | |

First 1-4 of 4 Last

Field Name	Sequence	Enabled	*Field Label	Template Control
EMPLID	1	<input checked="" type="checkbox"/>		<input type="checkbox"/>
GPAU_TAX_YEAR	<input type="text" value="5"/>	<input checked="" type="checkbox"/>	<input type="text" value="Tax Year"/>	<input checked="" type="checkbox"/>
PAY_ENTITY	<input type="text" value="7"/>	<input checked="" type="checkbox"/>	<input type="text" value="Pay Entity"/>	<input type="checkbox"/>
BALANCE_GRP_NUM	<input type="text" value="9"/>	<input type="checkbox"/>	<input type="text" value="Bal Grp Nbr"/>	<input type="checkbox"/>

To know more about defining report filters, see Application Fundamentals: Define Report Filters Page.

### Refreshing Report Security

The Self Service reports depends on two layers of security:

1. User's Primary Permission List country.
2. Security Query defined while enabling Report definition within the framework.

If the Security Query is not defined, then the report is available to all users whose primary permission list country matches with the report definition country. If the Security Query is defined, then the query result is used to enable the report. Here, the query result may be

1. EMPLOYEE ID - User ID of the Employee IDs returned by the query will be granted access to the report.
2. ROLENAME - Role Users will be granted access to the query.

The Report Security Application Engine process uses the above logic to load a Report Security Table with basic report details for each employee ID. The Self-Service pagelet uses this table to readily display the appropriate reports to employees. Use the Refresh Report Security page to refresh the report security data.

This example illustrates the fields and controls on the Refresh Report Security page.

### Refresh Report Security

The screenshot shows the 'Refresh Report Security' page. At the top, there are links for 'Run Control ID 01', 'Report Manager', and 'Process Monitor', along with a 'Run' button. Below this is a section titled 'Run Control Parameters' with three input fields and their corresponding values:

Field	Value	Description
Country	AUS	Australia
Group ID	AUSTRALIA	Australia Year-End Reports
Report ID	GPAUFRN	Payment Summary - Foreign Employment

To know more about refreshing report security, see Application Fundamentals: Refresh Report Security Page.

## How to view and download the Payment Summary Report

1. Receive notification from the employer to view or download the Payment Summary report.
2. Log on to the Employee Self Service (ESS) portal with your user id and password.
3. Click on the **Payment Summary Report** link under the Reports group.
4. Select the report filters to apply and generate the report.
5. View the report.
6. Download the report.

## Separating Eligible Termination Payment Data

If the system detects Lump Sum C ETPs during the Create Payment Summary process, it stores the data separately.

## Page Used to View ETP Data

Page Name	Definition Name	Usage
<a href="#">Review/Update ETP Data AUS Page</a>	GPAU_EE_ETP	View the breakup of Lump Sum C ETP payments by employee name and ID, Pay Entity, Balance Group ID and Tax Year.

## Review/Update ETP Data AUS Page

Use the Review/Update ETP Data AUS page (GPAU\_EE\_ETP) to view the breakup of Lump Sum C ETP payments by employee name and ID, Pay Entity, Balance Group ID and Tax Year.

Navigation:

**Global Payroll & Absence Mgmt**, and then **Year-End-Processing**, and then **Review/Update ETP Data AUS**, and then **Review/Update ETP Data AUS**

This example illustrates the fields and controls on the Review/Update ETP Data AUS page. You can find definitions for the fields and controls later on this page.

You can print ETP certificates using the **ETP Payment Summary** printing option on the Print Payments Summary page.

Field or Control	Description
<b>Status</b>	<p>Values are:</p> <p><i>Created</i>: The Create Payment Summary process has been run.</p> <p><i>Issued</i>: The ETP certificate has been printed. You can change the status from <i>Issued</i> to <i>Created</i> to regenerate the data through the Create Payment Summary process.</p> <p><i>Entered</i> and <i>Processed</i>: These are not applicable statuses for ETP certificates.</p>
<b>Payment Date</b>	The date that the ETP was made. The date appears by default as the payment check date of the employee's last pay.
<b>Payment Type</b>	Identifies the payment as either a transitional or non-transitional payment. Positive input to the earning elements ETP TRA TAX (Transitional ETP – Taxable) and ETP TRA NTAX (Transitional ETP – Non Taxable) are shown as transitional payments. While positive input to the earning elements ETP TAX (Life Benefit – Taxable) and ETP NONTAX (Life Benefit – Non Taxable) are shown as non-transitional ETP Payments.

### Eligible Service Period

Field or Control	Description
<b>Date Started</b>	The payee's hire date.
<b>Days before 1 July 1983</b>	If the hire date is before July 1, 1983, this is the difference between the hire date and July 1, 1983.
<b>Days after 30 June 1983</b>	<p>If the hire date is on or before June 30, 1983, this is the difference between June 30, 1983 and the termination date.</p> <p>If the hire date is after June 30, 1983, this is the difference between hire date and termination.</p>

### ETP Components

Field or Control	Description
<b>Pre-July 83 (X)</b>	System-calculated based on the <i>Days before 1 July 1983</i> result.
<b>Post-June 83 taxed (Y)</b>	System-calculated based on the <i>Days after 30 June 1983</i> result.
<b>Post-June 83 untaxed</b>	System-calculated based on the <i>Days after 30 June 1983</i> result.
<b>Post-June 94 Invalidation (Z)</b>	System-calculated based on any post June 1994 invalidity payments made.
<b>Gross Amount</b>	Sum of X, Y, and Z
<b>Tax Withheld</b>	Tax deducted from ETP.

---

Field or Control	Description
<b>Assessable Amount</b>	If the <b>Death Benefit</b> check box is selected, the assessable amount is 0.00. Otherwise, it is based on the following formula: $(0.05 \times \text{Pre-July 83}) + \text{Post-June 83 taxed or } (0.05 \times X) + Y$

---

# Monitoring Salary Packaging Expenditure

## Understanding Monitoring Salary Package Expenditure

The Administer Salary Packaging business process in Human Resources enables you to monitor and project employee expenses during a salary package period. It also provides tools to ensure that actual spending, for both employees and the organization, stays within the limits of budgeted salary packages. You can view package expenditures online as they take place, or generate reports that detail employee expenditures from their package budgets.

### Note

Before you can begin monitoring expenditures against a salary package, you must have completed the modeling, confirmation, and enrollment of the salary package in Human Resources. Doing so provides you with the base budgeted package against which your expenditure is tracked.

### Related Topics

- [PeopleSoft Human Resources Administer Salary Packaging: Modelling Salary Packages for Employees](#)
- [PeopleSoft Human Resources Administer Salary Packaging: Modelling Salary Packages for Applicants](#)
- [PeopleSoft Human Resources Administer Salary Packaging: Understanding Managing Salary Packages](#)

## Updating Expenditure Data for Employee Salary Packages

The integration of Administer Salary Packaging with the Human Resources and Global Payroll systems enables you to enter actual expenditures against a budgeted salary package. When you define components, you use the Expense Data page to identify whether the component is administered as a deduction, earnings, or expense type.

For deductions and earnings, expenditure is based on the payments made through Global Payroll. For components or additional components identified as expenses, expenditure is based on amounts that you enter on the Employee business expenses page in the Administer Workforce business process in Human Resources.

This topic discusses ways to update expenditure data for employee salary packages.

## Page Used to Update Expenditure Data for Employee Salary Packages

Page Name	Definition Name	Usage
<a href="#">Calculate Package Expenses AUS Page</a>	GPAU_RC_SP02	Run the Calculate Package process, which updates the Package Summary page, enabling you to view details of the budgeted, expended, and projected year-to-date totals for the package. This gives you vital information for observing and addressing spending and overspending trends.

### Related Topics

- PeopleSoft Human Resources Administer Workforce: Employee business expenses Page
- PeopleSoft Human Resources Administer Salary Packaging: Setting Up Package Components

## Calculate Package Expenses AUS Page

Use the Calculate Package Expenses AUS page (GPAU\_RC\_SP02) to run the Calculate Package process, which updates the Package Summary page, enabling you to view details of the budgeted, expended, and projected year-to-date totals for the package.

This gives you vital information for observing and addressing spending and overspending trends.

Navigation:

**Global Payroll & Absence Mgmt**, and then **Absence and Payroll Processing**, and then **Calculate Package Expenses AUS**, and then **Calculate Package Expenses AUS**

This example illustrates the fields and controls on the Calculate Package Expenses AUS page. You can find definitions for the fields and controls later on this page.

### Calculate Package Expenses AUS

Run Control ID 1
Report Manager Process Monitor
Run

**Report Request Parameters**

As Of Date

**Selection Criteria**

Empl ID  Justin Whitford

Empl Record

Delete Empl Expense History

Pay Group  Monthly Pay Group

#### Report Request Parameters

Field or Control	Description
<b>As Of Date</b>	The date on which package expenses are calculated. <b>Note:</b> Align this date with the pay period end date, end of a reporting period, and the end of the FBT or tax year. You should consider these dates when running the process.
<b>Delete Empl. Expense History</b> (delete employee expense history)	Select to delete previous expenses on the Package Summary page.

#### Package Expense Calculation Process

Regardless of the selection criteria, the package expense calculation is only completed for *confirmed* salary packages. This process retrieves the expenditure from the expenses and payroll tables and aggregates them in your Salary Packaging records.

You can view the actual and projected expenditure both online and as a report. To facilitate expense tracking throughout the package year, run the process on a regular basis. Typically, you run it at the completion of the payroll process, when you have the most up-to-date information on earnings and deductions paid through Global Payroll. Any expense amounts that have been entered through Business Expenses are included in the Package Expense Calculation.

You can run the expense calculation process as often as you like. You can also rerun the process if the expense details change—for example, when you add new business expenses to the employee's records.

**Note**

Components with a payroll type of None do not have any expenditure tracked against them unless they have expenses entered on the Expense Data page. Components with nothing on the Expense Data page do not have anything tracked against them, even if they enroll a payroll item.

## Entering Salary Packaging Business Expenses

When you define a component with an expense code on the Expense Data page, you enter expenditures for the employee using the Employee business expenses page. The amounts entered here do not affect payment of the expenses. You use this page merely for recording expenditures.

When tracking expenditures against expense codes, you must be sure that there is a unique expense code for each component included in the employee salary package model.

Business expenses relate to Administer Salary Packaging only if the expense code is linked to a package component on the Package Component Exp (expense) page of the Package Component table.

### Related Topics

- PeopleSoft Human Resources Administer Workforce: Employee business expenses Page

## Reviewing Salary Package Expenditures

Use the Salary Package Summary AUS component (which you access in the Review Absence/Payroll Info menu) to review the overall expenditure for an employee's salary package. You can also review the expenditures against individual components that make up a salary package.

Some of the components that are paid through the payroll system do not require close monitoring during the package year, as they are based on the details that you defined in the salary package. For example, expenditures for the employee's salary, health benefits, and superannuation will probably not vary much during the year. However, for components that are subject to ad hoc payments, you might monitor expenditure more closely. For example, an employee's actual spending against an expense account for motor vehicle operating costs could easily exceed the budgeted amount for the benefit if you do not monitor it carefully.

This topic discusses ways to review salary package expenditures.

## Pages Used to Review Salary Package Expenditures

Page Name	Definition Name	Usage
<a href="#">Period Summary Page</a>	GPAU_PKG_EXP_PRD	View actual and budget summary amounts for a package and its components by pay period. This information is stored in the Package Expense table.

Page Name	Definition Name	Usage
<a href="#">Package Summary Page</a>	GPAU_PKG_EE_EXP	View year-to-date employee package expense summary Information. Displays the actual expenses and budget amounts for an employee from the Year-to-Date Expenses table.

## Package Summary Page

Use the Package Summary page (GPAU\_PKG\_EE\_EXP) to view year-to-date employee package expense summary Information.

Displays the actual expenses and budget amounts for an employee from the Year-to-Date Expenses table.

Navigation:

**Global Payroll & Absence Mgmt**, and then **Absence and Payroll Processing**, and then **Review Absence/Payroll Info**, and then **Salary Package Summary AUS**, and then **Package Summary**

This example illustrates the fields and controls on the Package Summary page. You can find definitions for the fields and controls later on this page.

Period Summary		Package Summary	
<b>Lucas Ridgestone</b> Employee		Empl ID KA0016	Empl Record 0
Package Details		Package Start Date 01/01/2004	Package Status Current
		Period End Date 04/30/2004	
Total Package Value Components		Find   View All First 1-3 of 3 Last	
	Budgeted	Actual	Budget Variance
CAR	6165.76	6165.76	12331.60
SALARY	24666.68	24666.68	49333.32
SUPSGC	2466.68	2466.68	4933.32
Total Employee Cost Components		Find   View All First 1-3 of 3 Last	
CAR	6508.56	6508.56	13017.25
SALARY	26038.16	26038.16	52076.24
SUPSGC	2603.84	2603.84	5207.60
Package Total			
Total Total Package Value	33299.12	33299.12	66598.24
Total Total Employee Cost	35150.56	35150.56	70301.09
Non-Packaged Components			

Field or Control	Description
<b>As of Date</b>	<p>Indicates the date that the package expense calculation was processed. The page calculations include only those expenditures for the employee up to this date.</p> <p><b>Note:</b> Totals are divided into three areas—<b>TPV (total package value) Components</b>, <b>TEC (total employee cost) Components</b>, and the <b>Package Total</b>. The <b>TPV Components</b> and <b>TEC Components</b> identify each component, and they display the value of components that add to TPV and TEC respectively. These values include the component value and any additional components that add to that package total. The system also displays <b>Budgeted</b>, <b>Actual</b>, <b>Budget Variance</b>, and <b>Project Year End</b> totals.</p>

### Total Package Value Components and Total Employee Cost Components

Field or Control	Description
<b>Budgeted</b>	<p>The budgeted values for each component and the budget totals reflect in the package component details that you enter and adjust on the Employee Salary Package - Base Components pages.</p>

Field or Control	Description
<b>Actual</b>	<p>For each component, the system determines the expenditure based on the payroll type definition on the component. If a component is linked to an earnings type, any payment made against that earnings type is regarded as expenditure against the component if you've set up the component with an earnings type on the Expense Data page.</p> <p>The package expense calculation aggregates expenditure from business expenses and payroll data based on the preceding criteria. This process accounts for the expenditure against the base component amount but doesn't take into account additional component liabilities.</p> <p><b>Note:</b> For actual expenditure, the values processed through the payroll or entered in business expenses are disregarded for additional components. The system calculates additional component liabilities based on the percentage of the base component amount that has been expended.</p> <p>To display the actual expenditure for the component, the system calculates the additional component liability based on the percentage of the base component amount that the employee has expended. The system calculates these values and incorporates them into the display of the actual expenditure for each component that is listed on the Package Summary page.</p>
<b>Budget Variance</b>	<p>This amount represents the difference between the actual amount and the budgeted amount. It is expressed as a percentage of the budgeted amount. The system uses the following calculation to determine percentage variance amount:</p> $\text{(Actual Amount - Budget Amount)} \div \text{(Budget Amount} \times 100) = \text{Variance Amount}$

Field or Control	Description
<b>Project Year End</b>	<p>Depending on the method that you select for projecting values to year-end for the component, the system calculates this value accordingly. Different components use different methods and rates of expenditure. You identify whether a component is expended on a regular or ad hoc basis when you define components.</p> <p>For components identified with a regular rate of expenditure, the system uses the following method to project earnings:</p> $\text{Actual Expenditure} \div (\text{Total Days in Package Period} \times \text{Days Passed in the Package Period})$ <p>For components identified with an ad hoc rate of expenditure the system does not calculate a projection. Because they are expended at an ad hoc rate, it is not possible to presume any future expenditure.</p> <p>Because package periods can be for periods other than a single year, the projection amount is calculated to the package end, not to year's end.</p>
<b>Over Bud</b> (over budget)	<p>The <b>Over Bud</b> column displays either <i>Y</i> (yes) or <i>N</i> (no) to indicate whether the component is exceeding the assigned budget limits. The system determines whether a component or the package is over budget by prorating the package budget or the component budget. It calculates the value of the package or component from the start date to the package expense date. To determine any over- or underspends, the system compares the result to the actual expenditure as of the date you last ran the Expense Calculation process.</p>
<b>Package Total</b>	
Field or Control	Description
<b>Total Total Package Value</b> and <b>Total Total Employee Cost</b>	<p>For each column amount that is displayed in the <b>Total Package Value</b> and <b>Total Employee Cost Components</b> group boxes, the system provides the <b>Total Total Package Value</b> and <b>Total Total Employee Cost</b> in the <b>Package Total</b> group box.</p>

Field or Control	Description
<b>Non-Packaged Components</b>	<p>Because it is possible in an organization for earnings or deductions not included in the employee's salary package to be paid, the system also displays the non-packaged components. This field identifies the total value of any deductions, earnings, and expenses that are not included as a packaged component but have been paid out to the employee in the payroll.</p> <p>You can see if expenditure outside the package has occurred for the employee, and you can quickly respond to the non-packaged payments. These types of payments may prompt you to perform a package review or some other corrective action. To view the individual totals for these values, refer to the Non Packaged group box on the Period Summary page. The system displays the totals for non-packaged earnings, deductions, and expenses on the Period Summary page if any non-packaged payouts for these earnings types have taken place.</p> <p><b>Note:</b> You determine the non-packaged components that appear on the Package Summary page by using the Ern/Ded Included page.</p>

#### Related Topics

- PeopleSoft Human Resources Administer Salary Packaging: Setting Up Salary Packaging Human Resources and Global Payroll Tables
- PeopleSoft Human Resources Administer Salary Packaging: Modelling Salary Packages for Employees

## Checking Package Expenditure Progress During the Year

During the package year, you should review package expenditure on a regular basis to identify any potential over-expenditures on the part of the organization or employee.

You need information about employee benefits to determine whether you need to correct an over-expenditure at any time during the package period. Employees might not be aware of the rate of expenditure and may potentially overspend on their expense accounts.

## Period Summary Page

Use the Period Summary page (GPAU\_PKG\_EXP\_PRD) to view actual and budget summary amounts for a package and its components by pay period.

This information is stored in the Package Expense table.

Navigation:

**Global Payroll & Absence Mgmt**, and then **Absence and Payroll Processing**, and then **Review Absence/Payroll Info**, and then **Salary Package Summary AUS**, and then **Period Summary**

This example illustrates the fields and controls on the Period Summary page. You can find definitions for the fields and controls later on this page.

Period Summary		Package Summary	
<b>Lucas Ridgestone</b>		ID KA0016	Empl Record 0
Package Details		Find   View All	First 1 of 4 Last
Package Start Date	01/01/2004	Package Status	Current
Period End Date	04/30/2004		
Total Package Value Components		Find   View All	First 1-3 of 4 Last
		Budget	Actual
CAR		758.330	758.330
CAR	FBT	783.110	783.110
SALARY		6166.670	6166.670
			Budget Variance
Total Employee Cost Components		Find   View All	First 1-3 of 3 Last
CAR	PRT	85.700	85.700
SALARY	PRT	342.870	342.870
SUPSGC	PRT	34.290	34.290
Package Total			
Total Total Package Value		8324.78	8324.78
Total Total Employee Cost		8787.64	8787.64
Non-Packaged			
Earnings		Deductions	Expenses

**Field or Control**

**Description**

**Package Start Date and Period End Date**

The period end date is the end date for the pay period that you are viewing. The page calculations include only those expenditures for the employee for that indicated pay period.

**Note:** The information on the Package Summary pages is current up to the date that you run the Package Expense Calculation process, and the page calculations include only those pay period expenditures for the employees up to that date.

**Budget**

The budgeted values for each component and the budget totals are reflected in the package component details that you enter and adjust on the Employee Salary Package - Base Component pages.

## Non-Packaged

Field or Control	Description
<b>Earnings, Deductions, and Expenses</b>	<p>The Package Summary page includes a <b>Non-Packaged Components</b> group box to identify the total values of earnings, deductions, and expenses that are not included as a packaged components.</p> <p>All the other fields on this page are identical to the fields on the Package Summary page.</p> <p><b>Note:</b> You determine the non-packaged components that display appear on the Package Summary page using the Ern/Ded Included page.</p>

### Related Topics

- PeopleSoft Human Resources Administer Salary Packaging: Setting Up Salary Packaging Human Resources and Global Payroll Tables
- PeopleSoft Human Resources Administer Salary Packaging: Modelling Salary Packages for Employees

## Reconciling Payments at the End of the Package Period

During the package review process for each employee, you must reconcile expenditure in the previous package period. At this time, you should recover any overpayments, or make any adjustments for underpayments. Salary Packaging enables you to identify these amounts, but it doesn't automate any payment or recovery for package balances.

When reviewing these amounts, you should also consider the balances for each component and consider the reasons for the overspend or underspend before making any adjustments.

For example, at the end of the package period, you might find that one of the employee's salary components is under-spent. You should consider what has caused the underspend for the component. It might be that the employee took two weeks leave without pay. In that case, the underspend is valid and no adjustment should be made. Alternately, an expense account that is under-spent could have been under-utilized, and the employee should receive some adjustment for the balance remaining through payroll.

The actions that you take to acquit a salary package at year's end depend on your business practices. Some organizations allow balances to be carried forward to future years; others pay out or recover differences at year's end.

## Monitoring Expenditure Overspending and Underspending

The Package Summary pages clearly identify package and component overspending and underspending.

Some organizations choose not to control employee package expenditure at the component level. The package total information is most important to package administrators for these organizations. When budgeting or modelling packages, package administrators in these organizations define individual package components in the usual way. But component values act more as a guideline than a rule for tracking expenditures against the employee's package.

For organizations that are concerned with the overall package expenditure overspends and underspends, you can easily identify this information at the package level using the Package Summary pages. The pages also track expenditure at the component level, but expenditure caps are enforced at the package level.

In other organizations, business rules require that the package administrator track expenditure at the individual component level. Using the Package Summary pages, any overspending or underspending of the components is easy to see.

**Note**

The system does not issue warning messages regarding overspending or underspending of either packages or components in salary packages other than indicating that the package or the components are over- or under-spent on the Package Summary pages.

# Global Payroll for Australia Reports

## Global Payroll for Australia Reports: A to Z

These tables list the Global Payroll for Australia reports sorted by report ID. For more information about running these reports refer to:

For more information about running these reports, refer to:

- The corresponding topics in this product documentation.
- *PeopleTools: Process Scheduler*
- *PeopleTools: BI Publisher for PeopleSoft.*
- *PeopleTools: SQL Language Reference for PeopleSoft*

For samples of these reports, see the Report Samples that are published with this online documentation.

## Global Payroll for Australia: Australian Bureau of Statistics Reports

Report ID and Report Name	Description	Navigation	Run Control Page
GPAUPY16 Average Weekly Earnings (AWE)	These quarterly reports use earnings data stored in any of five Australian Bureau of Statistics (ABS) accumulators. Ensure that all earnings to be reported are included in the selected accumulators. The process produces both hardcopy reports and ASCII, comma-delimited electronic files.	<b>Global Payroll &amp; Absence Mgmt</b> , and then <b>Authority Correspondence</b> , and then <b>Print ABS Weekly Report AUS</b> , and then <b>ABS Average Weekly</b>	GPAU_RUNCTL_AWE
GPAUPY17 Survey of Employment & Earning (SEE)	Same as GPAUPY16.	<b>Global Payroll &amp; Absence Mgmt</b> , and then <b>Authority Correspondence</b> , and then <b>Print ABS Survey Report AUS</b> , and then <b>ABS Survey if E/E</b>	GPAU_RUNCTL_AWE

## Global Payroll for Australia: Additional Reports

Report ID and Report Name	Description	Navigation	Run Control Page
GPAUAM01 Absence History *	Lists, for each employee, all leave taken, with dates and duration, paid status, and other information. If you don't specify a leave type, the report lists all types.	<b>Global Payroll &amp; Absence Mgmt</b> , and then <b>Absence and Payroll Processing</b> , and then <b>Reports</b> , and then <b>Leave History AUS</b> , and then <b>Absence History</b>	GPAU_RC_ABS_HIST
GPAUAM02 Leave Liability *	Lists, for each employee, absence entitlement converted to leave liability. It includes the earning codes used to pass liability to the general ledger interface (GLI) or QSP. It shows rate and unit type, category (for QSP reporting), accrual date (pay date) balance units and the balance amount (Rate × Balance).	<b>Global Payroll &amp; Absence Mgmt</b> , and then <b>Absence and Payroll Processing</b> , and then <b>Reports</b> , and then <b>Leave Liability AUS</b> , and then <b>Leave Liability</b>	GPAU_RC_LVELIAB
GPAUPSO1 Payment Summary	Reports year-end payee earnings, which is a legislative requirement.	<b>Global Payroll &amp; Absence Mgmt</b> , and then <b>Year-End Processing</b> , and then <b>Payment Summary/ETP Certs AUS</b> , and then <b>Payment Summary - Print</b>	GPAU_RC_PSM_PRINT
GPAUPT01 State Payroll Tax	Lists, state by state, tax that is based on total salary per pay period.	<b>Global Payroll &amp; Absence Mgmt</b> , and then <b>Taxes</b> , and then <b>Payroll Tax Report AUS</b> , and then <b>State Payroll Tax Report</b>	GPAU_RC_SPT
GPAUPY01 Payslip *	Lists payee details of period earnings, taxes and other deductions, leave balances, and payment distributions.	<b>Global Payroll &amp; Absence Mgmt</b> , and then <b>Payslips</b> , and then <b>Create/Print Payslips AUS</b> , and then <b>Print Payslip</b>	GPAU_RUNCTL_PSLP

Report ID and Report Name	Description	Navigation	Run Control Page
GPAUPY15 Business Activity Statement	<p>The BAS Information Register report provides information to assist you to complete the organization's business activity statement.</p> <p>You specify From and To dates and the pay entities on which you report. You can print a summary version of this report.</p> <p>Employee tax appears in the Amt. Withheld No ABN column because employees don't have ABN numbers.</p>	<b>Global Payroll &amp; Absence Mgmt</b> , and then <b>Taxes</b> , and then <b>BAS Information Report AUS</b> , and then <b>BAS Information</b>	GPAU_RC_PY15
GPAUPY21 Payment Summary Exceptions	<p>Identifies discrepancies between the year-to-date amounts and actual results per period to avoid problems with payment summaries at year end. The report uses data extracted by the GPAU_PSM_EXC Application Engine process, which also reports any ETP exceptions.</p> <p>You run the report by tax year and pay entity and you can sort by payee name.</p>	<b>Global Payroll &amp; Absence Mgmt</b> , and then <b>Year-End Processing</b> , and then <b>Payment Summary Exceptions AUS</b> , and then <b>Payment Summary Exception</b>	GPAU_RC_PSM_EXCPT
GPAUPY22 Payment Summary Reconciliation	<p>Lists the results of the GPAU_PSM_CRE Application Engine process, which provides payment summary information.</p>	<b>Global Payroll &amp; Absence Mgmt</b> , and then <b>Year-End Processing</b> , and then <b>Payment Summary Reconcile AUS</b> , and then <b>Payment Summary - Reconciliation</b>	GPAU_RC_PSM_RECON
GPAUPY51 Net Payment Report	<p>Extracts data from the Cemtex Transaction and Header tables, from the Personal Data record, and from the Job record. You can have report at summary or detail level.</p>	<b>Global Payroll &amp; Absence Mgmt</b> , and then <b>Payment Processing</b> , and then <b>Net Payment Report AUS</b> , and then <b>Net Payment Report</b>	GPAU_PMT_RPT

Report ID and Report Name	Description	Navigation	Run Control Page
GPAUPY52 Recipient File Report	SQR version of the Recipient File - Electronic report, which details payment of deductions sent to recipients by Cemtex file. You can get the report automatically by running the Application Engine process for the electronic file or by selecting its check box and leaving the Application Engine check box deselected.	<b>Global Payroll &amp; Absence Mgmt</b> , and then <b>Payment Processing</b> , and then <b>Create Recipient File AUS</b> , and then <b>Recipient File - Electronic</b>	GPAU_RUNCTL_RCP_FL

### Related Topics

- [Understanding Leave Liability Reporting](#)  
The data that the report process extracts for leave liability reporting can be transferred to the GL through the GLI and included in the QSP financials file.
- [Printing Payslips](#)  
You print payslips by running the GPAUPY01 SQR process (select **Global Payroll & Absence Mgmt**, and then **Payslips**, and then **Create and Print Payslips AUS**).
- [Reporting Net Payment](#)  
The Net Payment report extracts data from the Cemtex Transaction table and the Header table and from the Personal Data and Job records.