

PeopleSoft Human Capital Management 9.2

PeopleSoft Payroll Interface



G49601-01
May 2026



PeopleSoft Human Capital Management 9.2 PeopleSoft Payroll Interface,

G49601-01

Copyright © 1988, 2026, Oracle and/or its affiliates.

This software and related documentation are provided under a license agreement containing restrictions on use and disclosure and are protected by intellectual property laws. Except as expressly permitted in your license agreement or allowed by law, you may not use, copy, reproduce, translate, broadcast, modify, license, transmit, distribute, exhibit, perform, publish, or display any part, in any form, or by any means. Reverse engineering, disassembly, or decompilation of this software, unless required by law for interoperability, is prohibited.

The information contained herein is subject to change without notice and is not warranted to be error-free. If you find any errors, please report them to us in writing.

If this is software, software documentation, data (as defined in the Federal Acquisition Regulation), or related documentation that is delivered to the U.S. Government or anyone licensing it on behalf of the U.S. Government, then the following notice is applicable:

U.S. GOVERNMENT END USERS: Oracle programs (including any operating system, integrated software, any programs embedded, installed, or activated on delivered hardware, and modifications of such programs) and Oracle computer documentation or other Oracle data delivered to or accessed by U.S. Government end users are "commercial computer software," "commercial computer software documentation," or "limited rights data" pursuant to the applicable Federal Acquisition Regulation and agency-specific supplemental regulations. As such, the use, reproduction, duplication, release, display, disclosure, modification, preparation of derivative works, and/or adaptation of i) Oracle programs (including any operating system, integrated software, any programs embedded, installed, or activated on delivered hardware, and modifications of such programs), ii) Oracle computer documentation and/or iii) other Oracle data, is subject to the rights and limitations specified in the license contained in the applicable contract. The terms governing the U.S. Government's use of Oracle cloud services are defined by the applicable contract for such services. No other rights are granted to the U.S. Government.

This software or hardware is developed for general use in a variety of information management applications. It is not developed or intended for use in any inherently dangerous applications, including applications that may create a risk of personal injury. If you use this software or hardware in dangerous applications, then you shall be responsible to take all appropriate fail-safe, backup, redundancy, and other measures to ensure its safe use. Oracle Corporation and its affiliates disclaim any liability for any damages caused by use of this software or hardware in dangerous applications.

Oracle®, Java, MySQL, and NetSuite are registered trademarks of Oracle and/or its affiliates. Other names may be trademarks of their respective owners.

Intel and Intel Inside are trademarks or registered trademarks of Intel Corporation. All SPARC trademarks are used under license and are trademarks or registered trademarks of SPARC International, Inc. AMD, Epyc, and the AMD logo are trademarks or registered trademarks of Advanced Micro Devices. UNIX is a registered trademark of The Open Group.

This software or hardware and documentation may provide access to or information about content, products, and services from third parties. Oracle Corporation and its affiliates are not responsible for and expressly disclaim all warranties of any kind with respect to third-party content, products, and services unless otherwise set forth in an applicable agreement between you and Oracle. Oracle Corporation and its affiliates will not be responsible for any loss, costs, or damages incurred due to your access to or use of third-party content, products, or services, except as set forth in an applicable agreement between you and Oracle.

Contents

Preface

Understanding the PeopleSoft Online Help and PeopleBooks	i
Using and Managing the PeopleSoft Online Help	iv
PeopleSoft HCM Related Links	iv
Contact Us	iv
Follow Us	v

1 Getting Started with PeopleSoft Payroll Interface

PeopleSoft Payroll Interface Overview	1
PeopleSoft Payroll Interface Business Processes	1
PeopleSoft Payroll Interface Integrations	1
PeopleSoft Payroll Interface Implementation	2

2 Understanding PeopleSoft Payroll Interface

Interface Definitions	1
Data Exchanges	3
Sample Data Definitions	5
Implementation Steps	5
Implementation Tasks	6
Preliminary Tasks	7
Implementation Team	7
Gap/Fit Analysis	8

3 Understanding PeopleSoft Payroll Interface Processing

Deduction Processing	1
Calculate Deductions Process Flow	1
DED_LINE and DED_CALC Tables	2
Deduction Processing and Multiple Jobs	3
Export Processing	4
Export Process Flow	5
Export Process Details	6

PI_PARTIC and PI_PARTIC_EXPT Tables	8
PI_EXTIO and PI_PARTIC_EXTBL Tables	12
Export Processing and Multiple Jobs	12
Import Processing	13
Import Process Flow	13
Import Tables	14
Export and Import Testing	15
Testing Exports and Imports	15
Successful Exports	16
Unsuccessful Exports	17
Detecting Errors	18
Table Management	20

4 Setting Up Earnings Data

Understanding Earnings	1
Setting Up Earnings Codes and Earnings Programs	1
Pages Used to Set Up Earnings Codes and Earnings Programs	1
Understanding Earnings Codes and Earnings Programs	2
Earnings Table - General Page	2
Earnings Program Table Page	2
Setting Up and Maintaining Additional Pay	3
Page Used to Set Up and Maintain Additional Pay	3
Understanding Additional Pay	3
Additional Pay Page	3

5 Setting Up Deduction Data

Understanding Deductions	1
Setting Up the Deduction Table	1
Pages Used to Set Up the Deduction Table	1
Understanding the Deduction Table	1
Deduction Table - Setup Page	2
Deduction Table - Tax Class Page	3
Deduction Table - Process Page	5
Deduction Table - Schedule Page	6
Viewing Benefit Deductions	7
Pages Used to View Benefit Deductions	7
Understanding Benefit Deductions	8
Benefit Program Page	8
Assign to Benefit Program Page	9
Setting Up and Maintaining General Deductions	9

Pages Used to Set Up and Maintain General Deductions	10
Understanding General Deductions	10
Deduction Table - Setup Page	10
General Deduction Table Page	11
General Deduction Page	12
Overriding General Deductions Page	13

6 Setting Up Tax Data

Understanding Tax Data	1
Setting Up Tax Location Data	2
(CAN) (USA) Setting Up Company Tax Data	2
(CAN) (USA) Setting Up and Maintaining Tax Distribution Data	3
Pages Used to Set Up and Maintain Tax Distribution Data (USA and CAN)	3
Update Tax Distribution Page	3
Update Tax Distribution Page	3
(USA) Setting Up and Maintaining U.S. Employee Tax Data	4
Pages Used to Set Up and Maintain U.S. Employee Tax Data	4
Federal Tax Data Page	4
State Tax Data Page	5
Local Tax Data Page	5
(CAN) Setting Up and Maintaining Canadian Employee Tax Data	5
Pages Used to Set Up and Maintain Canadian Employee Tax Data	5
Canadian Income Tax Data Page	6
Quebec Income Tax Data Page	6
Provincial Income Tax Data Page	6

7 Setting Up Payroll Schedules

Understanding Payroll Schedules	1
Setting Up Pay Groups	1
Pages Used to Set Up Pay Groups	1
Understanding Pay Groups	2
Pay Group Table - Definition Page	2
Process Control Page	3
Calc Parameters Page	4
Bank/Tip Info Page	5
Setting Up Balance IDs	5
Setting Up Pay Run IDs	5
Setting Up Pay Calendars	6

8 Cloning a Payroll Interface Definition

Understanding the Cloning Process	1
Cloning an Interface Definition	3
Pages Used to Clone an Interface Definition	3
Clone Payroll Interface Page	3

9 Setting Up a Payroll Interface Definition (Part 1)

Understanding the Control Tables	1
Common Elements Used in Working with Control Tables	2
Setting Up the System Table	2
Pages Used to Set Up the System Table	2
Understanding the System Table	2
Interface System Table 1 Page	2
Interface System Table 2 Page	7
Setting Up the Employee Table	8
Page Used to Set Up the Employee Table	8
Understanding the Employee Table	9
Interface Employee Table Page	9
Setting Up the PS Tables	10
Pages Used to Set Up the PS Tables	10
Understanding the PS Tables	10
PS Tables Page	10
Setting Up the Field Definition Table	14
Pages Used to Set Up the Field Definition Table	14
Understanding the Field Definition Table	15
Interface Field1 Page	15
Interface Field2 Page	17
Setting Up the Definition Table	19
Pages Used to Set Up the Definition Table	19
Understanding the Definition Table	19
Interface Definition File Page	19
Interface Definition Record Page	21
Interface Definition Fields Page	24
Setting Up the Group Table	26
Page Used to Set Up the Group Table	26
Understanding the Group Table	26
Interface Group Table Page	26
Setting Up the Instance Table	27
Page Used to Set Up the Instance Table	28
Understanding the Instance Table	28

Interface Instance Table Page	28
Setting Up the Process Table	29
Page Used to Set Up the Process Table	30
Understanding the Process Table	30
Interface Process Table Page	30
Setting Up the File Handle Table	31
Page Used to Set Up the File Handle Table	32
Understanding the File Handle Table	32
Interface File Handle Table Page	32
Setting Up the Configuration Table	33
Page Used to Set Up the Configuration Table	33
Understanding the Configuration Table	33
Interface Configuration Table Page	34

10 Setting Up a Payroll Interface Definition (Part 2)

Working with Interface Definitions	1
(USF) Setting Up an NFC Export Interface Definition	1
Setting Up a DETI Import Interface Definition	2
Defining a New Import Interface Definition	4
Working with Character Sets	6
Working with Text Translate Values	9
Working with Company Filtering	10
Working with Key Fields	11
Working with COBOL Processes	12
Reviewing Delivered COBOL Processes	12
Reviewing Delivered COBOL Processes for Special Events	24
Creating COBOL Routines	25
Working with Smart Select	26
Working with Transactions	28
Understanding Transactions	28
Setting Up a Transaction	29
Setting Up a Stop Transaction	35
Verifying a Transaction	39
Verifying a Stop Transaction	42

11 Maintaining Payroll Data

Understanding Payroll Data	1
Maintaining Additional Pay	2
Maintaining General Deductions	2
Maintaining Tax Distribution Data	2

Maintaining Employee Tax Data	2
(CAN) (USA) Setting Up and Maintaining Direct Deposit	2
Setting Up and Maintaining Optional Payroll Data	3
Pages Used to Set Up and Maintain Optional Payroll Data	3
Understanding Optional Payroll Data	3
Payroll Options 1 Page	3
Payroll Options 2 Page	5
(CAN) Setting Up and Maintaining Source Deductions	7
Page Used to Set Up and Maintain Source Deductions	7
Understanding Source Deduction Processing	7
Update Source Deductions Page	7

12 Running Deductions

Understanding Deduction Processing	1
Calculating Deductions	2
Pages Used to Calculate Deductions	3
Calculate Deductions Page	3
Confirming or Unconfirming Deductions	4
Pages Used to Confirm or Unconfirm Deductions	4
Confirm Deductions Page	4
Reviewing Deductions	5
Pages Used to Review Deductions	5
Review Deductions Page	5

13 Running Exports and Imports

Understanding Data Exchanges	1
Exporting or Importing Data	2
Pages Used to Export and Import Data	2
Import/Export Payroll Data Page	2
Creating the Export File Separately	6
Pages Used to Create the Export File Separately	6
Complete Export to File Page	6
Converting Tab-Delimited Import Files	7
Pages Used to Convert Tab-Delimited Import Files	7
Convert Tab Delimiter Page	7
Reviewing Exports or Imports	8
Pages Used to Review Exports or Imports	8

14 PeopleSoft Payroll Interface Reports

PeopleSoft Payroll Interface Reports: A to Z	1
Data Reports	1
Payroll Reports	3
Interface Definition Reports	6

Preface

Understanding the PeopleSoft Online Help and PeopleBooks

The PeopleSoft Online Help is a website that enables you to view all help content for PeopleSoft applications and PeopleTools. The help provides standard navigation and full-text searching, as well as context-sensitive online help for PeopleSoft users.

Hosted PeopleSoft Online Help

You can access the hosted PeopleSoft Online Help on the [Oracle Help Center](#). The hosted PeopleSoft Online Help is updated on a regular schedule, ensuring that you have access to the most current documentation. This reduces the need to view separate documentation posts for application maintenance on My Oracle Support. The hosted PeopleSoft Online Help is available in English only.

To configure the context-sensitive help for your PeopleSoft applications to use the Oracle Help Center, see [Configuring Context-Sensitive Help Using the Hosted Online Help](#).

Locally Installed PeopleSoft Online Help

If you're setting up an on-premises PeopleSoft environment, and your organization has firewall restrictions that prevent you from using the hosted PeopleSoft Online Help, you can install the online help locally. Installable PeopleSoft Online Help is made available with selected PeopleSoft Update Images and with PeopleTools releases for on-premises installations, through the [Oracle Software Delivery Cloud](#).

Your installation documentation includes a chapter with instructions for how to install the online help for your business environment. The documentation zip file may contain a README.txt file with additional installation instructions. See *PeopleSoft 9.2 Application Installation* for your database platform, "Installing PeopleSoft Online Help."

Installable PeopleSoft Online Help now includes PDF versions of each PeopleBook. For more information, see [Understanding Locally Installed PeopleSoft Online Help](#).

Downloadable PeopleBook PDF Files

You can access downloadable PDF versions of the help content in the traditional PeopleBook format on the [Oracle Help Center](#). The content in the PeopleBook PDFs is the same as the content in the PeopleSoft Online Help, but it has a different structure and it does not include the interactive navigation features that are available in the online help.

Common Help Documentation

Common help documentation contains information that applies to multiple applications. The three main types of common help are:

- Application Fundamentals
- Using PeopleSoft Applications
- Using and Managing the PeopleSoft Online Help

Most product families provide a set of application fundamentals help topics that discuss essential information about the setup and design of your system. This information applies to many or all applications in the PeopleSoft product family. Whether you are implementing a single application, some combination of applications within the product family, or the entire product family, you should be familiar with the contents of the appropriate application fundamentals help. They provide the starting points for fundamental implementation tasks.

In addition, the *PeopleTools: Applications User's Guide* introduces you to the various elements of the PeopleSoft Pure Internet Architecture. It also explains how to use the navigational hierarchy, components, and pages to perform basic functions as you navigate through the system. While your application or implementation may differ, the topics in this user's guide provide general information about using PeopleSoft applications.

Finally, *Using and Managing the PeopleSoft Online Help* (this guide) introduces you to the setup, features, and usage of the online help system.

Field and Control Definitions

PeopleSoft documentation includes definitions for most fields and controls that appear on application pages. These definitions describe how to use a field or control, where populated values come from, the effects of selecting certain values, and so on. If a field or control is not defined, then it either requires no additional explanation or is documented in a common elements section earlier in the documentation. For example, the Date field rarely requires additional explanation and may not be defined in the documentation for some pages.

Typographical Conventions

The following table describes the typographical conventions that are used in the online help.

Typographical Convention	Description
<u>Key+Key</u>	Indicates a key combination action. For example, a plus sign (+) between keys means that you must hold down the first key while you press the second key. For <u>Alt+W</u> , hold down the <u>Alt</u> key while you press the <u>W</u> key.
. . . (ellipses)	Indicate that the preceding item or series can be repeated any number of times in PeopleCode syntax.
{ } (curly braces)	Indicate a choice between two options in PeopleCode syntax. Options are separated by a pipe ().
[] (square brackets)	Indicate optional items in PeopleCode syntax.
& (ampersand)	When placed before a parameter in PeopleCode syntax, an ampersand indicates that the parameter is an already instantiated object. Ampersands also precede all PeopleCode variables.

Typographical Convention	Description
⇒	This continuation character has been inserted at the end of a line of code that has been wrapped at the page margin. The code should be viewed or entered as a single, continuous line of code without the continuation character.

ISO Country and Currency Codes

PeopleSoft Online Help topics use International Organization for Standardization (ISO) country and currency codes to identify country-specific information and monetary amounts.

ISO country codes may appear as country identifiers, and ISO currency codes may appear as currency identifiers in your PeopleSoft documentation. Reference to an ISO country code in your documentation does not imply that your application includes every ISO country code. The following example is a country-specific heading: "(FRA) Hiring an Employee."

The PeopleSoft Currency Code table (CURRENCY_CD_TBL) contains sample currency code data. The Currency Code table is based on ISO Standard 4217, "Codes for the representation of currencies," and also relies on ISO country codes in the Country table (COUNTRY_TBL). The navigation to the pages where you maintain currency code and country information depends on which PeopleSoft applications you are using. To access the pages for maintaining the Currency Code and Country tables, consult the online help for your applications for more information.

Region, Country, and Industry Identifiers

Information that applies only to a specific region or industry is preceded by a standard identifier in parentheses. This identifier typically appears at the beginning of a section heading, but it may also appear at the beginning of a note or other text.

An example of a region-specific heading is: "(Latin America) Setting Up Depreciation"

Region Identifiers

Regions are identified by the region name. The following are examples of region identifiers that may appear in PeopleSoft Online Help:

- Asia Pacific
- Europe
- Latin America
- North America

Country Identifiers

Countries are identified by a three-letter country code. The following are examples of country identifiers that may appear in the PeopleSoft Online Help:

- ARG (Argentina)
- AUS (Australia)
- CAN (Canada)
- NLD (The Netherlands)

Industry Identifiers

Industries are identified by the industry name or by an abbreviation for that industry. The following are examples of industry identifiers that may appear in the PeopleSoft Online Help:

- USF (U.S. Federal)
- E&G (Education and Government)

Translations and Embedded Help

PeopleSoft 9.2 software applications include translated embedded help. With the 9.2 release, PeopleSoft aligns with the other Oracle applications by focusing our translation efforts on embedded help. We are not planning to translate our traditional online help and PeopleBooks documentation. Instead we offer very direct translated help at crucial spots within our application through our embedded help widgets. Additionally, we have a one-to-one mapping of application and help translations, meaning that the software and embedded help translation footprint is identical—something we were never able to accomplish in the past.

Using and Managing the PeopleSoft Online Help

Select About This Help in the left navigation panel on any page in the PeopleSoft Online Help to see information on the following topics:

- Using the PeopleSoft Online Help.
- Managing hosted Online Help.
- Managing locally installed PeopleSoft Online Help.

PeopleSoft HCM Related Links

[Oracle Help Center](#)

[PeopleSoft Online Help Home](#)

[PeopleSoft Information Portal](#)

[My Oracle Support](#)

[PeopleSoft Training from Oracle University](#)

[PeopleSoft Video Feature Overviews on YouTube](#)

Application Fundamentals: HCM Abbreviations





[PeopleSoft Spotlight Series](#)

Contact Us

Send your suggestions to psoft-infodev_us@oracle.com.

Please include the applications update image or PeopleTools release that you're using.

Follow Us

Icon	Link
	Watch PeopleSoft on YouTube
	Follow @PeopleSoft_Info on X.
	Read PeopleSoft Blogs
	Connect with PeopleSoft on LinkedIn

1

Getting Started with PeopleSoft Payroll Interface

PeopleSoft Payroll Interface Overview

PeopleSoft Payroll Interface is a table-driven, generic export and import engine that enables you to exchange data between PeopleSoft HCM and a third-party payroll system.

With Payroll Interface you maintain employee data in PeopleSoft HCM while using the third-party payroll system to perform the payroll processing functions. Data is exchanged between the two systems using the Payroll Interface Export and Import processes.

This diagram illustrates PeopleSoft Payroll Interface.

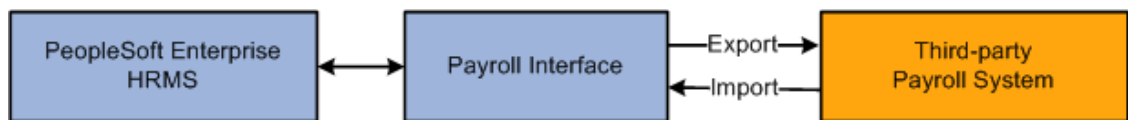

PeopleSoft Payroll Interface Business Processes

PeopleSoft Payroll Interface provides these business processes:

- Maintain payroll data.
- Run (calculate and confirm) deductions.
- Run exports and imports (exchange data).

We discuss these business processes in the business process topics in this product documentation.

PeopleSoft Payroll Interface Integrations

PeopleSoft Payroll Interface integrates with these PeopleSoft applications:

This diagram illustrates the PeopleSoft applications with which Payroll Interface integrates.

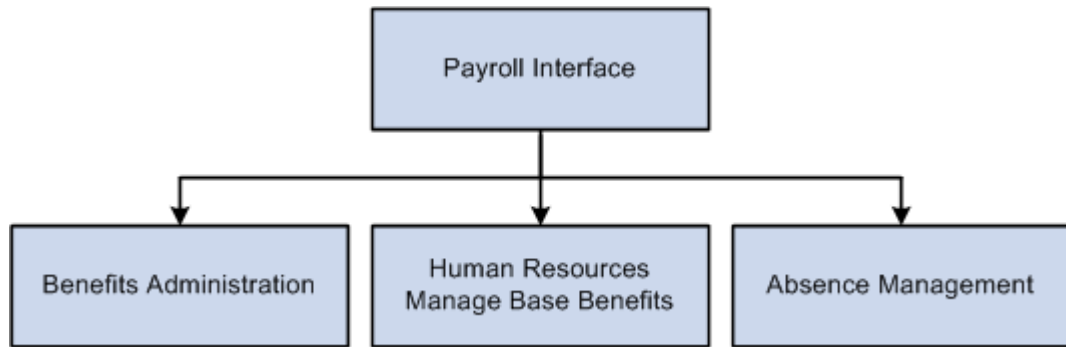

We discuss integration considerations in the implementation topics in this product documentation.

Supplemental information about third-party application integrations is located on the My Oracle Support website.

PeopleSoft Payroll Interface Implementation

PeopleSoft Setup Manager enables you to generate a list of setup tasks for your organization based on the features that you are implementing. The setup tasks include the components that you must set up, listed in the order in which you must enter data into the component tables, and links to the corresponding product documentation.

Other Sources of Information

In the planning phase of your implementation, take advantage of all PeopleSoft sources of information, including the installation documentation, table-loading sequences, and data models.

Refer to the *PeopleSoft HCM 9.2 - Reorganization of Component Interface Permissions* (Doc ID 2342162.1) article on My Oracle Support for a list of system-delivered CIs and their usage, the mapping of CIs and associated permission lists, and the mapping of CI permission lists and user roles.

For more information, see:

- Application Fundamentals
- *PeopleTools: Setup Manager*

2

Understanding PeopleSoft Payroll Interface

Interface Definitions

Payroll Interface is a table-driven export and import engine that enables you to exchange data between PeopleSoft HCM and a third-party payroll system. Data exchanges are set up through the export and import interface definitions, which enable you to download data from or upload data to database tables:

- The export interface definition retrieves, formats, and downloads payroll-related data from various PeopleSoft HCM tables. The Export process writes the data to either a flat file or a database table.
- The import interface definition uploads the processed payroll results into seven Payroll Interface import tables located in PeopleSoft HCM. The Import process reads data only from ASCII files.

Export Interface Definition

The export interface definition includes the payroll setup and the interface definition. The payroll setup identifies the payroll-related data (earnings, deductions, taxes, and so forth) and determines the pay schedules (the pay groups and pay calendars that determine which employees are processed during the export run). The interface definition determines the data mapping between the PeopleSoft HCM system and the third-party payroll system, defines the SQL retrievals and any additional COBOL processing, and specifies the export file format.

This diagram illustrates the export framework:

This diagram illustrates the export framework:

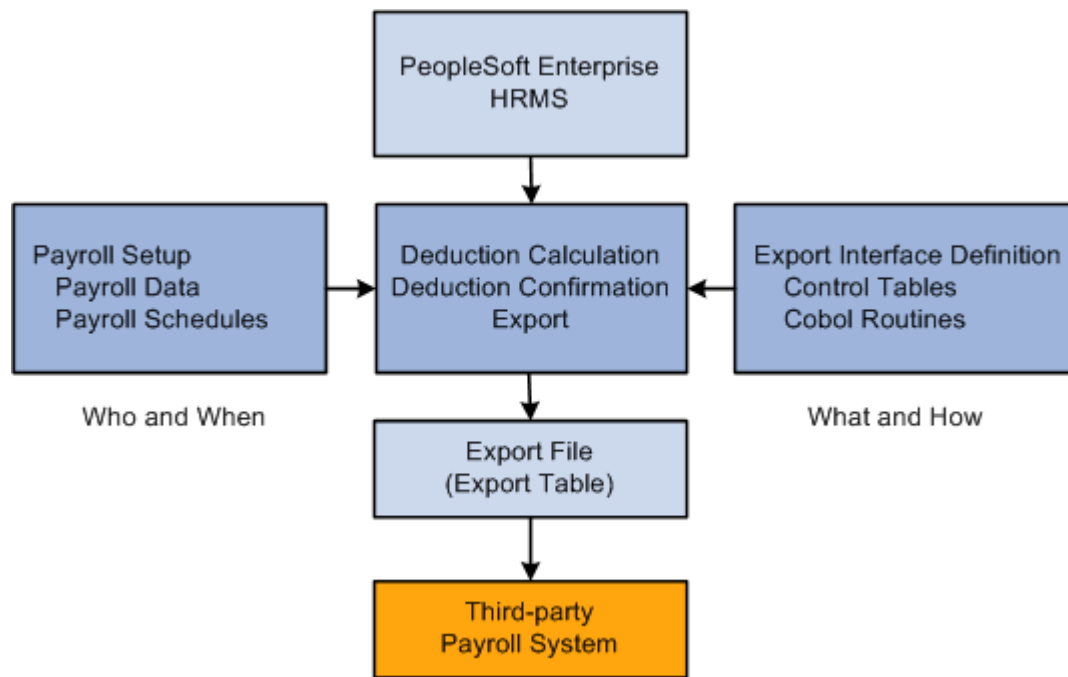

Import Interface Definition

The import interface definition is simpler—and more limited—than the export interface definition. The interface definition is set up such that the Import process can locate the import file and then load the processed payroll data into the seven Payroll Interface import tables. You do not need to set up any type of scheduling; the Import process can be run as soon as the import file is made available.

Note

The Import process does not perform data auditing or reverse translations. Depending on your implementation, you may want to write a custom Structured Query Report (SQR) program that performs these functions as well as loads the data into the seven import tables.

This diagram illustrates the import framework:

This diagram illustrates the import framework.

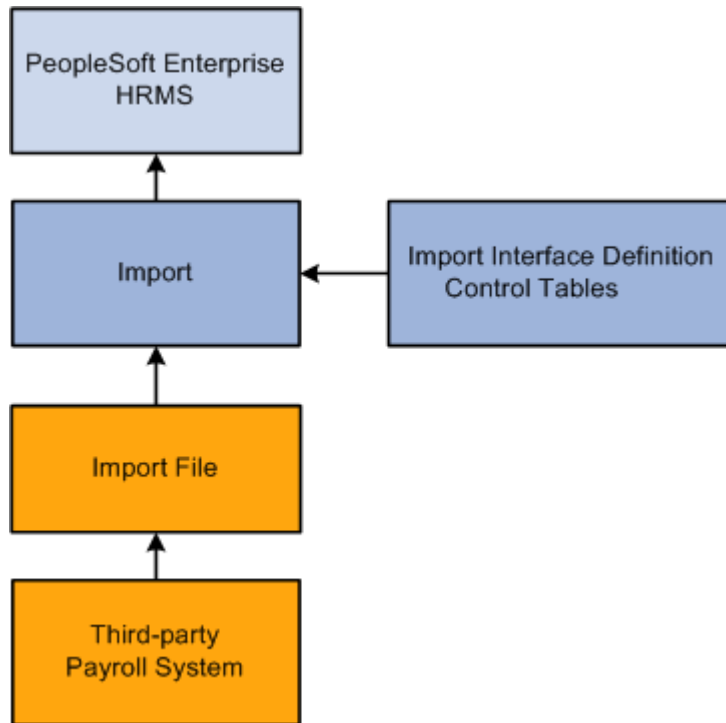

Data Exchanges

Payroll Interface enables you to maintain employee data in PeopleSoft HCM while using the third-party payroll system to perform the payroll processing functions. With Payroll Interface, data exchanges between the two systems are performed in four phases:

1. (Optional) Run the Calculate Deductions and Deduction Confirmation processes to calculate and confirm pay period deductions.
2. Run the Export process to retrieve and write the pay (and deduction) data from PeopleSoft HCM to an export file or table.
3. Make the export file or table available to the third-party payroll vendor. The third-party vendor uses the appropriate software solution to load the data into the third-party payroll system, to perform the payroll processing functions, and to write the processed payroll results to one or more import files.
4. (Optional) Run the Import process to read the import file and load the processed payroll data back into PeopleSoft HCM.

This diagram illustrates the Payroll Interface Deduction, Export, and Import processes:

This diagram illustrates the Payroll Interface Deduction, Export, and Import processes.

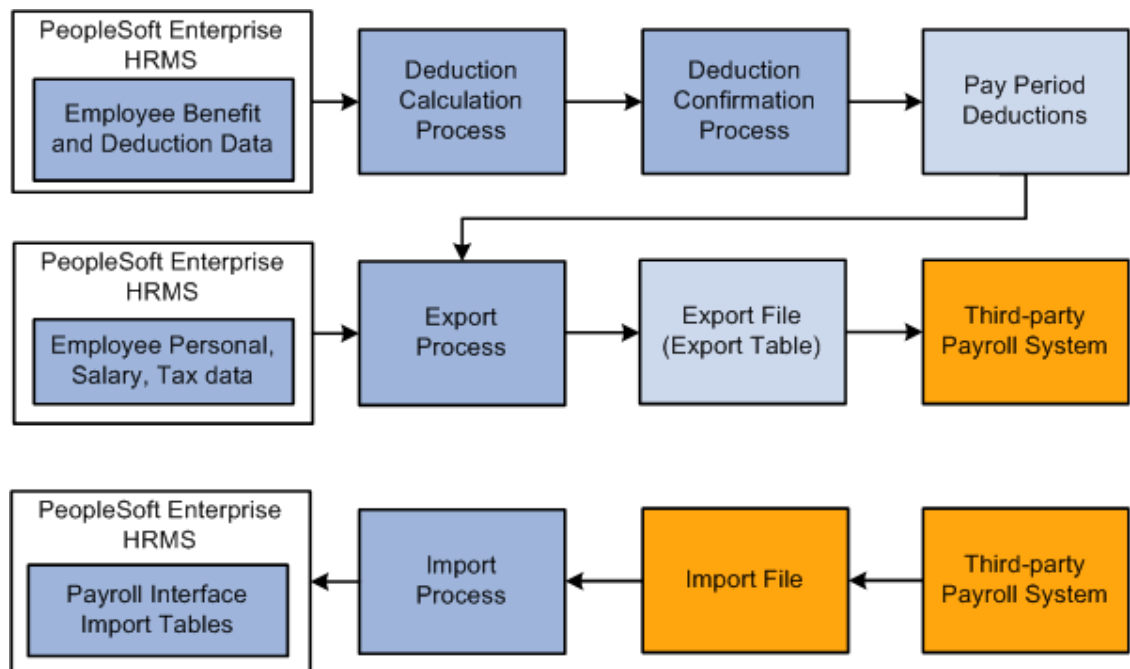

Deduction Process

You have the option of maintaining employee deduction information in PeopleSoft HCM using the PeopleSoft HR Manage Base Benefits business process. If you maintain deductions, you must run the Calculate Deductions and Deduction Confirmation processes before you run the Export process. The deduction processes calculate and confirm per pay period benefit and general deduction amounts.

Note

If you do not maintain deductions (that is, if the third-party payroll system manages all deduction information) then you do not need to run the Calculate Deductions or Deduction Confirmation processes.

Export Process

The Export process exports employee-level personal, job, salary, deduction, and tax information that the third-party payroll system needs to produce paychecks each pay period. Payroll Interface can export data from any PeopleSoft HCM table that includes the PeopleSoft EmplID field as a key field. Data is exported to either a flat file or a database table.

Payroll Interface does not perform any payroll calculations. The third-party payroll system performs the tax calculations, earnings calculations, gross-to-net calculations, and year-end processing. You use Payroll Interface to track and export changes that occur, during a pay period, to static employee payroll-related data. The data is considered static because it rarely changes, for example, a person's job code, pay rate, tax status, number of dependents, or benefit plan (which can be changed only during an open enrollment period).

⚠ Warning

Payroll Interface is designed to export changes to *static* employee payroll-related data; for example, job codes, benefit deductions, or wages - information that does not change that often during the course of a year. Dynamic or transactional pay data, such as monthly commission payments or time and labor calculations, must be set up and maintained by the third-party payroll system.

Import Process

You have the option of importing the payroll results produced by the third-party payroll system back into PeopleSoft HCM. The Import process loads payroll check, earnings, deduction, and tax data into seven Payroll Interface import tables. Once loaded, the data can be viewed online or by running reports. Data is imported only from ASCII files.

ℹ Note

Further processing or technical configuration may be required to check the validity of the imported data or to ensure that the data can be accessed in a secure manner.

Sample Data Definitions

PeopleSoft delivers sample data definitions for use with Payroll Interface. You can often more easily begin an implementation by cloning (copying) one of the sample data definitions.

The export sample data definitions are logical (LOG), physical (PHY), comma-separated value (CSV), and National Finance Center (NFC) for the federal government. The import sample data definitions are check detail (DETI) and check balance (BALI). Corresponding system IDs, configuration IDs, and file IDs are set up for most of these definitions.

⚠ Warning

Do not assume that the sample data is complete or that it will function in a production environment without further modification.

Related Topics

- [Cloning an Interface Definition](#)
- [Working with Interface Definitions](#)
This topic discusses how to:

Implementation Steps

To set up, test, and install a payroll interface, follow these steps. As you perform the tasks outlined here, document everything; this will help you to troubleshoot any problems that arise.

Step	Tasks
1. Assemble an implementation team and perform the gap/fit analysis.	See Implementation Tasks .
2. Set up the PeopleSoft HCM core and foundation table components.	See Application Fundamentals
3. (optional) Set up PeopleSoft HR Manage Base Benefits. Note: Perform this step only if you maintain benefit deductions.	See PeopleSoft Human Resources Manage Base Benefits.
4. Set up export (or import) interface. Note: The import interface is usually set up and tested after you have set up and tested the export interface.	Perform these tasks: <ul style="list-style-type: none"> Set up the payroll data and schedules. See: Understanding Earnings Understanding Deductions Understanding Tax Data Understanding Payroll Schedules. (optional) Clone an existing interface definition. See Understanding the Cloning Process. Set up the export (or import) interface definition. See: Understanding the Control Tables Working with Interface Definitions.
5. Test the export (or import) interface.	Using the sample data or a copy of the live system, perform these tasks: <ul style="list-style-type: none"> (optional) Run the Calculate Deductions and Deduction Confirmation processes until error free. See Understanding Deduction Processing. Run the Export (or Import) process until error free. See Understanding Data Exchanges.
6. Install the export (or import) interface.	Using the live system: <ul style="list-style-type: none"> Install the export (or import) interface. Run the Calculate Deductions and Deduction Confirmation processes, the Export process, and the Import process (whichever apply). Train users to set up and maintain payroll data. Train users to run the Calculate Deductions and Confirmation processes, the Export process, or the Import process (which ever apply).

Implementation Tasks

This topic discusses:

- Preliminary tasks.
- Implementation team.

- Gap/fit analysis.

Preliminary Tasks

Implementing a payroll interface requires a thorough understanding of PeopleSoft HCM and the requirements of the third-party payroll system. To ensure a smooth implementation, you should:

- Secure full executive sponsorship.
You need cooperation from multiple departments, such as payroll, human resources, finance, and information services.
- Set aside sufficient time and resources.
Implementing a payroll interface requires design, planning, development, implementation, and testing. While strong project management is especially critical for global implementations with multiple companies, all implementations require a firm hand with scheduling and details.
- Attend Payroll Interface training.
Implementing a payroll interface requires both functional and technical expertise. Practice first by using the delivered sample data to understand how Payroll Interface works. Then, create your own definitions and output file using the delivered demo data as the model. Finally, copy a "live" database—don't use the actual live database—from your organization. Configure it and test run the Payroll Interface Calculate Deductions and Confirmation processes and the Export and Import processes using your organization's actual data.
- Apply any software updates or fixes.
Contact My Oracle Support for any applicable patches that have been posted since the general release.
- Obtain the vendor documentation.
Obtain a complete set of documentation from the third-party payroll vendor. The payroll interface that you set up is based on the data, formatting, and processing requirements of the third-party payroll system.

Implementation Team

Recommended team members for a payroll interface implementation include:

- Payroll interface lead.
The lead is responsible for the payroll interface setup and configuration, and for the initial export/import of data. The lead must understand Payroll Interface as well as the third-party payroll system. Keep the backup lead informed during the entire implementation process.
- Payroll functional lead.
The lead is the recipient of the exported payroll data file. The lead should know about payroll codes, employee payroll data, and the steps involved in processing payroll. The lead needs to understand the third-party payroll system capabilities, if not its technical details.
- Database administrator (DBA) technical lead.
The lead manages PeopleSoft table maintenance, technical configurations, SQL, PeopleTools, the Application Engine, COBOL, and PeopleCode.
- HCM functional lead.

The lead must understand PeopleSoft HCM data and the transactions and business processes involving a payroll interface, including benefits and deduction calculations.

- HCM project lead.

The lead manages a payroll interface implementation and ongoing maintenance. Sometimes another team member takes on these duties.

Gap/Fit Analysis

The gap/fit analysis is the most important step in the implementation process. This is where you identify exactly what needs to be set up in the export interface definition (and to a lesser extent, the import interface definition).

Conduct a Functional Analysis

Analyze your functional requirements:

- Establish data ownership.

Establish who owns the data, typically either the human resources or the payroll department.

- Identify business processes, transactions, and data flow.

Create a flow chart that shows data movement in different situations, such as for new hires, transfers, and pay rate changes.

- Determine common data elements.

Determine common elements and relationships between the existing employee data and the requirements of the third-party application. Identify field mapping and translation requirements.

Conduct a Technical Analysis

Analyze your technical requirements:

- Identify the PeopleSoft tables and fields.

Identify the tables and fields containing employee-level payroll-related data to be exported. Depending on the data requirements of the third-party payroll system, you may need to create additional views.

- Identify the third-party payroll system fields.

Identify the third-party payroll system fields that will receive the data that is exported from PeopleSoft HCM. Understand the third-party payroll system import specifications. Refer to the vendor documentation or use the third-party payroll system's technical support for assistance.

- Identify data gaps.

Identify and isolate any gaps between PeopleSoft HCM and the third-party payroll system. Isolate requirements as early as possible. Any gaps will have to be bridged using special processes, routines, calculations, or conditional logic.

Obtain the Vendor Documentation

It is critical that you obtain the vendor documentation for the third-party payroll system. The vendor documentation contains the requirements for the third-party payroll system and will guide you in setting up the export or import interface definition.

Work with the third-party vendor to answer the following types of questions:

- What file format is required for import (for example, comma-delimited or a physical sequence)? Is there a choice on the type of fields exported? Which type of file is recommended for personal data?
- What's the required file layout? For example, should there be a header record using field names or field name codes followed by the value? Also, should there be a trailer record?
- Can you accept a flat file of employee data each pay period? (That is, a full export instead of just changes.)
- What are file naming conventions? Where should export files be placed?
- Do earnings and personal data need to be in separate files?
- Are any fields effective-dated?
- What is the unique key field or combination of fields that identifies an employee? For example, payroll ID or national ID (SSN).
- What fields are mandatory? Are fields different for new hires or changes to existing data? Do any fields need to be paired or grouped together?
- What is the maximum number of fields per output record?
- Can new hires and changes be in the same file?
- Are there user-defined lists, such as cost center lists, that have to be pre-loaded with PeopleSoft HCM values? (For each user-defined list, you need the third-party payroll provider's values to set up correct data mappings.)
- Are there reports that validate the payroll interface export file, for example, a report that identifies changes to the system?
- Who prepares the export file from the third-party payroll system?
- How do you set up a test database with the third-party payroll software? (You should run test imports into the third-party system, but you do not want to touch the production database.)

Perform the Data Mapping

Data mapping between PeopleSoft HCM and the third-party payroll system is a vital implementation step. Base your data mapping on the information gathered during the functional and technical analyses. Data mapping requires two considerations:

- PeopleSoft field locations must match up with third-party payroll system field locations.
For example, if your third-party payroll system receives data for hire status in the 30th position of a physical export file, then you must configure Payroll Interface to place this data in the 30th position of your export file.
- Data values must be translated accurately.
For example, the hire-status value for active employees is maintained in PeopleSoft HCM as *Active*. In the third-party payroll system, the same data might be maintained using the value *A*. To map the PeopleSoft data to the third-party payroll system, you would need to construct your file export process to write a value of *A* to the export file every time it sees a value of *Active* in the PeopleSoft data (because the value of *Active* means nothing to the third-party payroll system).

To map values between PeopleSoft HCM and the third-party payroll system, use translate values.

See [Setting Up the Field Definition Table](#).

Note

(USF) Every effort is made to ensure that the National Finance Center (NFC) sample data that is delivered with Payroll Interface conforms to NFC requirements. However, you should always check the data mapping in the delivered export configuration for accuracy.

This graphic shows a spreadsheet you can use as a starting point to facilitate data mapping:

This graphic shows a spreadsheet you can use as a starting point to facilitate data mapping.

Spreadsheet Column Heading
Third-party field name
Third-party field values
Third-party field format
Payroll Interface field name
Length
Description
PeopleSoft record (table) field name
PeopleSoft/Third-party translate values
Payroll Interface field format
Comments
Third-party requirements

Note

Use the Payroll Interface field name to set up the interface file definition when you define the export/import file layouts.

Assess Employee Actions

Payroll Interface uses the PeopleSoft employee ID (EmplID) to track and export changes that occur to employee payroll-related data. The PeopleSoft employee ID must be mapped to the third-party payroll system employee ID. Analyze your human resources, benefits, and payroll transactions; make sure you understand the relationships between these transactions and the requirements of the third-party payroll system.

This table lists the types of questions to ask during the analysis:

Action	Questions
Hires	<ul style="list-style-type: none"> • What ID do you use for payroll? • How do you assign employee IDs? • How does the payroll system identify new hires? • Are there special requirements for a new-hire transaction? • What are the minimum required data fields?
Rehires	<ul style="list-style-type: none"> • How are rehires processed? • Is the same payroll ID used over and over again? • How does the payroll system set up a rehire? Are preexisting or new IDs used? • What impact might existing rehire procedures have on Payroll Interface?
Terminations	<ul style="list-style-type: none"> • How does the payroll system handle terminations? • Do you need to send over a special code? • Do you need to zero out compensation values? • Do you need to zero out date fields? Do you need to send any stop transactions?
Employee ID Changes	Do you need a procedure to translate the third-party payroll system employee ID to the PeopleSoft EmplID?

3

Understanding PeopleSoft Payroll Interface Processing

Deduction Processing

This topic discusses:

- Calculate Deductions process flow.
- DED_LINE and DED_CALC tables.
- Deduction processing and multiple jobs.

Calculate Deductions Process Flow

This diagram illustrates the Calculate Deductions process flow:

This diagram illustrates the Calculate Deductions process flow.

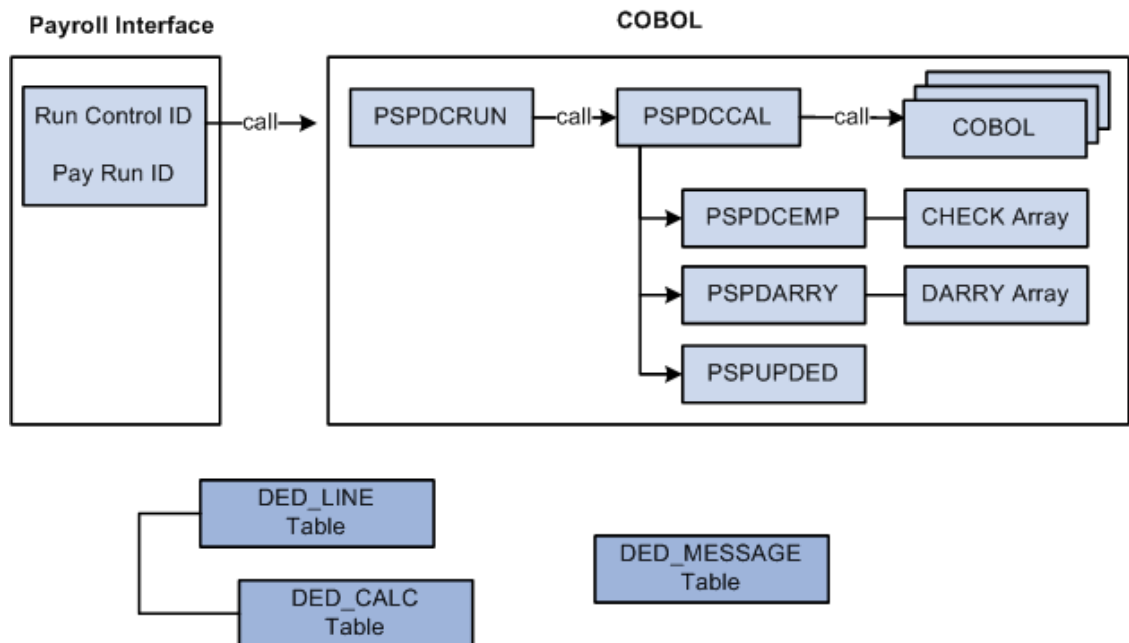

Deduction processing occurs in the following way:

1. To start the Calculate Deductions process, enter a pay run ID and other parameters using the Calculate Deductions (RUNCTL_DED_CALC) component, Calculate Deductions page.
2. PSPDCRUN reads the pay run ID and calls PSPDCCAL.
3. PSPDCCAL calls the COBOL routines required to process deductions.

4. PSPDCCAL calls PSPDCEMP, which in turn creates the CHECK array.
5. PSPDCCAL calls PSPDARRY, which in turn creates the DARRY array.
6. PSPDCCAL calls PSPUPDED, which populates the DED_LINE and DED_CALC tables.

PSPDCCAL calls PSPDCEMP

The PSPDCEMP COBOL routine:

- Selects the jobs and benefit programs to be processed by PSPDARRY.
- Stores the EMPL_RCD and BEN_RCD that might exist for the EMPLID in the CHECK array.

PSPDCCAL calls PSPDARRY

The PSPDARRY COBOL routine:

- Uses the CHECK array to select and calculate the deduction values that should be taken from an employee's check.
- Stores the calculated deduction values in the DARRY array.

PSPDCCAL calls PSPUPDED

The PSPUPDED COBOL routine writes the results of the Calculate Deductions process to the DED_LINE and DED_CALC tables.

Note

The EMPLID/EMPL_RCD key field combinations for an employee are determined using the CHECK and DARRY arrays.

DED_LINE and DED_CALC Tables

Payroll Interface stores the results of the Calculate Deductions and Deduction Confirmation processes in three tables: DED_CALC, DED_LINE, and DED_MESSAGE.

This diagram illustrates the parent-child relationship between the DED_LINE and DED_CALC tables:

This diagram illustrates the parent-child relationship between the DED_LINE and DED_CALC tables.

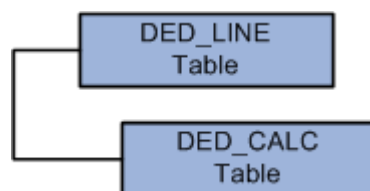

DED_LINE Table

The DED_LINE table stores the EMPLID and EMPL_RCD key fields that are required to identify and process an employee. The value of the PAY_LINE_STATUS field indicates whether

the process finished successfully or failed. You can view the results using the Review Deductions (DED_CALCULATIONS) component.

Possible PAY_LINE_STATUS values are:

- **Calculated (C):** Deductions were calculated; no errors occurred
- **Confirmed (F):** Deductions were confirmed; no errors occurred.
- **Error (E):** An error occurred.
- **Updated by user (U):** An error occurred.
- **Pay in progress (P):** An error occurred.

DED_CALC Table

The DED_CALC table stores the EMPLID and EMPL_RCD key fields that are required to identify an employee as well as the results of the Calculate Deductions process, including the deduction codes and amounts for each. You can view results using the Review Deductions component.

DED_MESSAGE Table

The DED_MESSAGE table stores the EMPLID and EMPL_RCD key fields that are required to identify an employee and is populated only if an error occurs during the Calculate Deductions or Deduction Confirmation process. You can view the error messages using the Review Error Messages (DED_MESSAGE) component.

Deduction Processing and Multiple Jobs

To calculate deductions for an employee with multiple jobs, the following criteria is used:

- An employee with multiple jobs can have different benefit programs for each job.
- If an employee has multiple jobs, some of which use the same benefit program, one of the jobs must be selected as the primary job.
- If an employee has multiple jobs, all of which use different benefit programs, each job is selected as the primary job.
- Deductions are calculated only for primary jobs.

This table shows possible job and benefit program combinations for three employees:

EMPLID	EMPL_RCD	Benefit Program	Benefit Record Number	Primary Benefit Job
8412	0	BAS	0	Y
8412	1	FLX	1	Y
8412	2	FLX	1	N
8200	0	BAS	0	Y
8300	0	BAS	0	Y
8300	1	BAS	0	N

Benefit deductions use key fields EMPLID and EMPL_RCD. General deductions use key fields EMPLID and COMPANY (but not EMPL_RCD). Because the key fields are not the same, benefit deductions and general deductions are processed differently. The following tables show the deduction results for the employee whose EMPLID is 8421.

CHECK Array:

EMPLID	Benefit Program (index for more than one)	BEN_RCD
8421	BAS	0
8421	FLX	1

DARRY Array:

Benefit Plan	Benefit Program	BEN_RCD
20 Life	BAS	0
00 (general)	<i>none</i>	999
20 LifeX	FLX	1

DED_CALC table results:

Company	Pay Group	Pay End Date	EMPLID	EMPLID_RCD	Plan Type	Benefit Plan
PST	WK1	07/03/00	8412	0	20	LIFE
PST	WK1	07/03/00	8412	0	00	<i>none</i>
PST	FLX	07/03/00	8412	1	20	LIFEX

Benefit Deductions

In the preceding example, Payroll Interface treats each EMPLID/EMPL_RCD key field combination as a separate row of information; each job is treated as a separate check. The EMPLID and all multiple jobs will be run through the deduction calculation process. Although a separate row is created for each multiple job in the payroll interface, all of the employee's multiple job deductions are processed at the same time.

General Deductions

In the preceding example, general deductions should be taken against only one of the jobs. However, because general deductions do not include the EMPL_RCD key field, you must manually select the EMPL_RCD using the Payroll Options (PAYROLL_DATA) component, Payroll Options 2 page, Deduction Calc Record field. The Deduction Calc Record (Deduction Calculation Record) field appears for employees who have:

- Multiple jobs in the same company.
- Different benefit programs for each job.
- General deductions.

Related Topics

- [Export Processing and Multiple Jobs](#)
To export data for an employee with multiple jobs, the following criteria is used:

Export Processing

This topic discusses:

- Export process flow.

- Export process details.
- PI_PARTIC and PI_PARTIC_EXPT tables.
- PI_EXTIO and PI_PARTIC_EXTBL tables.
- Export processing and multiple jobs.

Export Process Flow

This diagram illustrates the Export process flow:

This diagram illustrates the Export process flow.

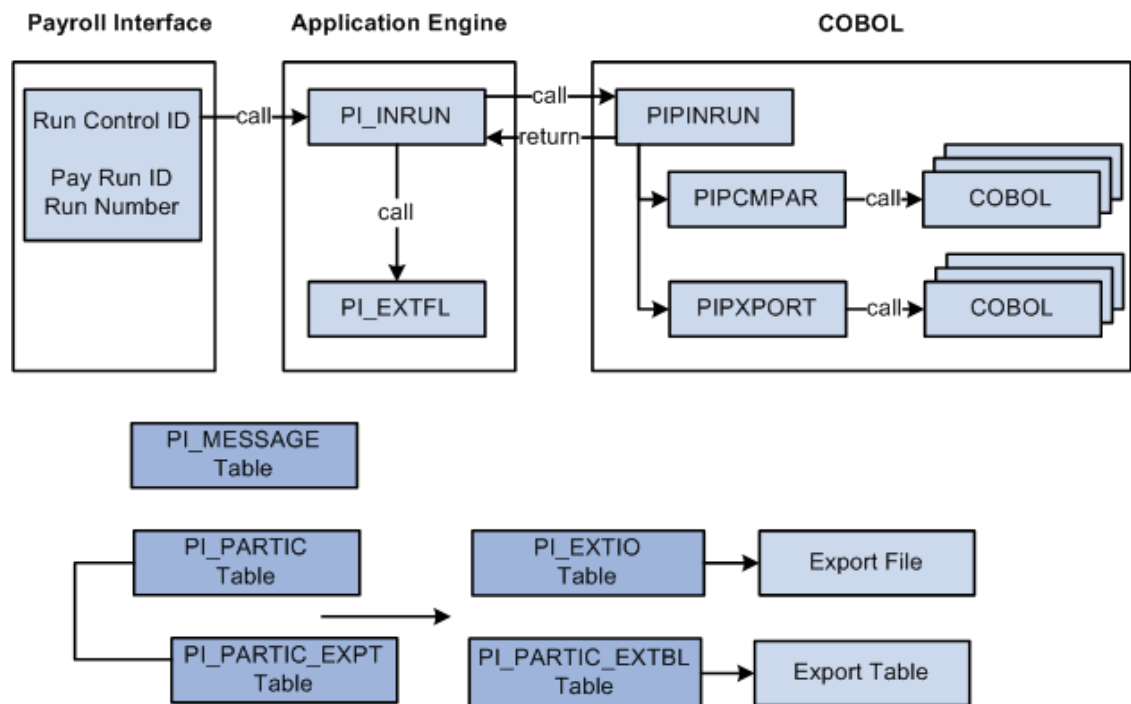

Export processing occurs in the following way:

1. To start the Export process, use the Import/Export Payroll Data (PI_RUNCTL_PNL) component, Import/Export Payroll Data run control page to enter the pay run ID, payroll interface run number, and other parameters.
2. PI_INRUN reads the pay run ID and run number and calls PIPINRUN.
3. PIPINRUN calls PIPCMPAR (which in turn calls other subroutines). PIPCMPAR *selects, compares, and exports* data to tables PI_PARTIC and PI_PARTIC_EXPT.
4. PIPINRUN calls PIPXPORT (which in turn calls other subroutines). PIPXPORT reads table PI_PARTIC_EXPT, transfers the changed data to temporary table PI_EXTIO or PI_PARTIC_EXTBL.
5. PIPINRUN returns control to PI_INRUN.
6. PI_INRUN calls PI_EXTFL.
7. If exporting to a file, PI_EXTFL reads the data in PI_EXTIO and creates the export file. If exporting to a table, PI_EXTFL reads the data in PI_PARTIC_EXTBL and creates the export table.

Export Process Details

The Export process includes three phases — select, compare, and export:

- During the select phase, payroll data is retrieved from the PeopleSoft HCM tables.
- During the compare phase, the selected data is compared against the data from the previous export run.

The comparison phase identifies any data changes that have occurred since the last export.

- During the export phase, the data is exported to either a flat file or a table.

A full-records export performs the select and export phases; all data is exported. A changes-only export performs the select, compare, and export phases; only data that has changed is exported.

PI_INRUN calls PIPINRUN

Export processing is based on the pay run ID and run number. For each pay run ID, PIPINRUN retrieves the company and pay group from the pay calendars. The company and pay group are used to verify the payroll interface definitions and to select the employees who will be processed.

PIPINRUN calls PIPCMPAR

First, PIPCMPAR verifies the payroll interface setup for the selected configuration ID:

1. Using the company and pay group, PIPCMPAR obtains the configuration ID from the Pay Group table.

Using the configuration ID, it retrieves the file definitions and the system ID from the Configuration table.

- a. For the selected system ID, PIPCMPAR verifies all records and fields in PS Tables table.
 - b. For the selected system ID, PIPCMPAR verifies all fields in the Field Definition table.
 - c. PIPCMPAR verifies that all the parameters defined in the Definition table are valid.
2. Using the company and pay group, PIPCMPAR *selects* from the Job table all employees (with status values defined in the System table) with a matching company and pay group.

Second, PIPCMPAR performs the actual export process. The export process differs for full-records exports and changes-only exports.

1. For a full-records export, PIPCMPAR does the following for each selected employee in the pay group:
 - a. For each table defined in PS Tables, retrieves rows based on the where clause definition (as well as instance IDs, process IDs, and other information that is set up in the interface).
 - b. *Exports* the results to tables PI_PARTIC and PI_PARTIC_EXPT in the format specified in the Definition table (LOG, PHY, CSV, and so on).

Note

For full-records exports, all values are considered new, and therefore, changed. Flags in the PI_PARTIC and PI_PARTIC_EXPT tables are initialized to Y and 1.

2. Changes-only export, PIPCMPAR, does the following for each selected employee in the pay group:
 - a. For each table defined in PS Tables, retrieves rows based on the where clause definition (as well as instance IDs, process IDs, and other information that is set up in the interface).
 - b. *Compares* the value of each field (and row, if designated) to the value that was sent in the last export (the previous run number).
 - c. *Exports* the results to table PI_PARTIC and PI_PARTIC_EXPT in the format specified in the Definition table (LOG, PHY, CSV).

Note

For changes-only exports, flags in the PI_PARTIC and PI_PARTIC_EXPT tables are set to Y and 1 if values change or to N and 0 if values do not change.

PIPINRUN calls PIPXPORT

PIPXPORT reads table PI_PARTIC_EXPT and writes the changed data to temporary table PI_EXTIO or PI_PARTIC_EXTBL.

Note

If no changes occurred, table PI_EXTIO or PI_PARTIC_EXTBL is empty at the end of the export process.

PI_INRUN calls PI_EXTFL

When the export processing is finished, control returns to the Application Engine. PI_INRUN calls PI_EXTFL to create the export file.

PI_EXTFL does the following:

1. For each row of data in table PI_EXTIO:

Writes a line to the export file defined in the File Handle table for the file definition. The data is written in the character set defined on the PI System table (LOG, PHY, CSV, and so on).
2. Deletes the contents of table PI_EXTIO.
3. Deletes the run control record.

PI_PARTIC and PI_PARTIC_EXPT Tables

When a full-records or changes-only export is processed, flags are set in the PI_PARTIC and PI_PARTIC_EXPT tables. The values of these flags determine which data is written to the export file (or table).

This diagram illustrates the parent-child relationship between the PI_PARTIC and PI_PARTIC_EXPT tables:

This diagram illustrates the parent-child relationship between the PI_PARTIC and PI_PARTIC_EXPT tables.

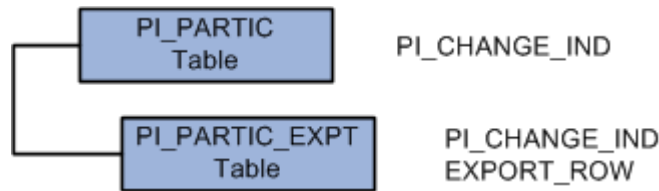

The PI_PARTIC table contains one row of data for every employee and for every process. It contains high-level information that determines which employees are processed during the comparison phase. Two key fields in this table are EMPLID and PI_RUN_NUM. The PI_RUN_NUM is very important when doing a reprocess run. A critical field on the PI_PARTIC table is PI_CHANGE_IND. If an employee has had a data change since the last Export process, the PI_CHANGE_IND flag is set to Y.

The PI_PARTIC_EXPT table contains the historical (changed) data for the comparison phase. New rows are inserted into this table during each Export process run. Every field that will be sent to the third-party payroll system is in this table. In front of each data element on the PI_PARTIC_EXPT table is a change flag. If the field has changed since the last process, this flag is set to 1; otherwise, it is set to 0. If the field belongs to a group, the data element is prefixed with 2.

Within the PI_PARTIC_EXPT table, the Export Row column is a 250-byte character representation of employee-level data. This data field is the result of information that is set up using the Definition Table (INTRFC_DEFINITION) component. If there is more than 250 bytes of data, another row is inserted into the table and the EXPORT_SEQ is incremented. The export row is positional and is based on the order of the fields that are set up using the Definition Table component. This is very important for maintenance during live processing.

PI_PARTIC Table

If values change, PI_CHANGE_IND is set to Y.

Possible run status indicators for a successful export run are:

Field	Value
PI_PARTIC_STATUS	<ul style="list-style-type: none"> Compared (C). Process is complete. Compare Error (E). An error occurred. In Progress (P). Process is running. <p>Note: When the process finishes, the flag should be set to C or E. If the flag is set to P, then an error has occurred.</p>

Field	Value
PI_CHANGE_IND	<ul style="list-style-type: none"> Change (Y). Data has changed since the previous export. Process Change (P). Data has changed and caused a process to occur. No Change (N). No data has changed. <p>Note: Some data changes trigger a process; for example, if an employee is terminated, a stop transaction for deductions may be issued.</p>
PI_CHANGE_TYPE	<ul style="list-style-type: none"> New Hire (N). The employee is a new hire. All data is sent to PI_PARTIC_EXPT. Data (D). Data changed. Process (P). Data has changed and caused a process to occur. Reactive Pay (R). The employee has been rehired. Terminated Pay (T). The employee has been terminated. Blank. No data changed. No data was sent to PI_PARTIC_EXPT.

PI_PARTIC_EXPT Table

If values change, PI_CHANGE_IND is set to Y and the byte-length field flags that are attached to each field value are set to 0, 1, or 2. All exported data is written to EXPORT_ROW, a 250-character field. If the export file is defined at a length greater than 252 characters, then data is loaded into additional EXPORT_ROW fields and the EXPORT_SEQ sequence field is incremented.

Possible run status indicators for a successful export run are:

Field	Value
PI_CHANGE_IND	<ul style="list-style-type: none"> Change (Y). Data has changed. Data fields with a 1 flag will be exported. Process change (P). Data has changed and caused a process to occur. No change (N or blank). No data fields will be exported.
EXPORT_ROW	<ul style="list-style-type: none"> Zero (0). No change. One (1). Change. Two (2). Change in a group field.

Example 1

Assume the following for the employee with EmplID KUI001:

- Full-records export, run number 1.
- Data values for salary, union dues, savings bond, and vehicle allowance.

Export	Run Num	Salary	U-Dues	SV-BND	VEH
Full-records	1	1500	10	100	15

PI_PARTIC table—This is a full-records export and all data values are considered changed. PI_CHANGE_IND is set to Y.

Field	Values
EMPL_ID	KUI001
PI_RUN_NUM	1
PI_CHANGE_IND	Y

PI_PARTIC_EXPT table—PI_CHANGE_IND is set to Y and the byte-length field flag is set to 1 for all data values.

Field	Values
EMPL_ID	KUI001
PI_RUN_NUM	1
PI_CHANGE_IND	Y
EXPORT_ROW	11500 110 1100 115

Export file—All data values are written to the export file (or table).

Employee (EMPLID)	Salary	U-DUES	SV-BND	VEH
KUI001	1500	10	100	15

Example 2

Assume the following for the employee with EmplID KUI001:

- Changes-only export, run number 2.
- Data values for salary and savings bond have changed.

Export	Run Num	Salary	U-Dues	SV-BND	VEH
Full-records	1	1500	10	100	15
Changes-only	2	1800	10	150	15

PI_PARTIC table—PI_CHANGE_IND is set to Y.

Field	Values
EMPL_ID	KUI001
PI_RUN_NUM	2
PI_CHANGE_IND	Y

PI_PARTIC_EXPT table—PI_CHANGE_IND is set to Y and the byte-length field flag is set to 1 for data values that have changed and to 0 for data values that have not changed.

Field	Values
EMPL_ID	KUI001
PI_RUN_NUM	2

Field	Values
PI_CHANGE_IND	Y
EXPORT_ROW	11800 010 1150 015

Export file—Changed data values are written to the export file (or table).

Employee (EMPLID)	Salary	U-DUES	SV-BND	VEH
KUI001	1800		150	

Example 3

Assume the following for the employee with EMPLID KUI001:

- Changes-only export, run number 3.
- No data values have changed.

Export	Run Num	Salary	U-Dues	SV-BND	VEH
Full-records	1	1500	10	100	15
Changes-only	2	1800	10	150	15
Changes-only	3	1800	10	150	15

PI_PARTIC table — PI_CHANGE_IND is set to N.

Field	Values
EMPL_ID	KUI001
PI_RUN_NUM	3
PI_CHANGE_IND	N

PI_PARTIC_EXPT table — PI_CHANGE_IND is set to N and the byte-length field flag is set to 0 for all field values.

Field	Values
EMPL_ID	KUI001
PI_RUN_NUM	3
PI_CHANGE_IND	N
EXPORT_ROW	01800 010 0150 015

Export file — No data values have changed; no data is written to the export file (or table).

Employee (EMPLID)	Salary	U-DUES	SV-BND	VEH
KUI001				

PI_EXTIO and PI_PARTIC_EXTBL Tables

The Export process can write data to either an export file or an export table.

This diagram illustrates exporting data to either a file or table:

This diagram illustrates exporting data to either a file or table.

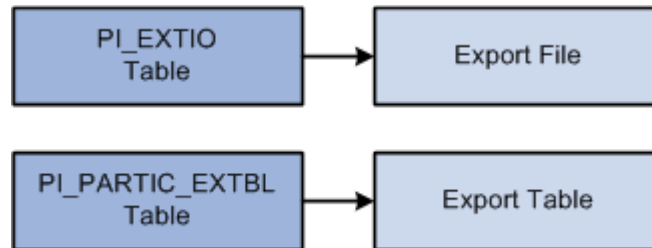

PI_EXTIO Table

In the PI_EXTIO table, the REC_DATA_PARTIAL field should contain the exact contents of the external file. However, if the record length of the external file exceeds 252 bytes, then the rows in PI_EXTIO are split and the RECDATA_SEQ_NO field is incremented.

PI_PARTIC_EXTBL Table

In the PI_PARTIC_EXTBL table, a row for each changed field is written and the SEQ_NUM field is incremented by 1 unless the field has a group ID assigned to it. For fields with group IDs, the same SEQ_NUM is applied to all fields in the group. For the sequence numbering logic to work properly, you must set up grouped fields correctly. For example, the DED group ID can be used to pair the Deduction Code and Deduction Amount fields. These two fields must adjoin each other on the record; fields without the DED group ID cannot be positioned between them.

See [Setting Up the Definition Table](#).

Export Processing and Multiple Jobs

To export data for an employee with multiple jobs, the following criteria is used:

- An export record is created for each job that is set up with a Payroll Interface company/pay group.
- All records that use the employee record number in the key send the appropriate data for that record number.
- All records that do not contain the employee record number in the key (for example, personal data) send the same information that applies to all export records.
- All of the employee's jobs are exported, whether the jobs are from the same or different pay groups or the same or different companies.
- When a concurrent job is added or terminated, it is processed the same way that a single job is added or terminated.

If you define unique IDs by combining the PeopleSoft EMPLID and record (job) number, you create separate employees in the third-party payroll system for each job.

If you use multiple jobs in PeopleSoft HCM, but only want to export a single job through Payroll Interface, you might instead identify a particular job record number for all employees, then create an instance ID attached to the record-mapped-to job, to include only that specific job record number.

Payroll System IDs

You can add another key besides the PeopleSoft EMPLID, the national ID, and the payroll interface employee ID. You can use a view, the multiple national ID field on the personal data pages, or the Payroll Interface existing translation logic. The approach that you choose depends on the third-party payroll requirements.

If you need a single check, create a view to combine the values into one amount for each deduction code. Payroll Interface treats each employee ID or employee record number as a separate row of information. Each job is treated as a separate check. This gives you tremendous flexibility when mapping information to the third-party payroll system.

Related Topics

- [Deduction Processing and Multiple Jobs](#)
To calculate deductions for an employee with multiple jobs, the following criteria is used:

Import Processing

This topic discusses:

- Import process flow.
- Import tables.

Import Process Flow

This diagram illustrates the Import process flow:

This diagram illustrates the Import process flow.

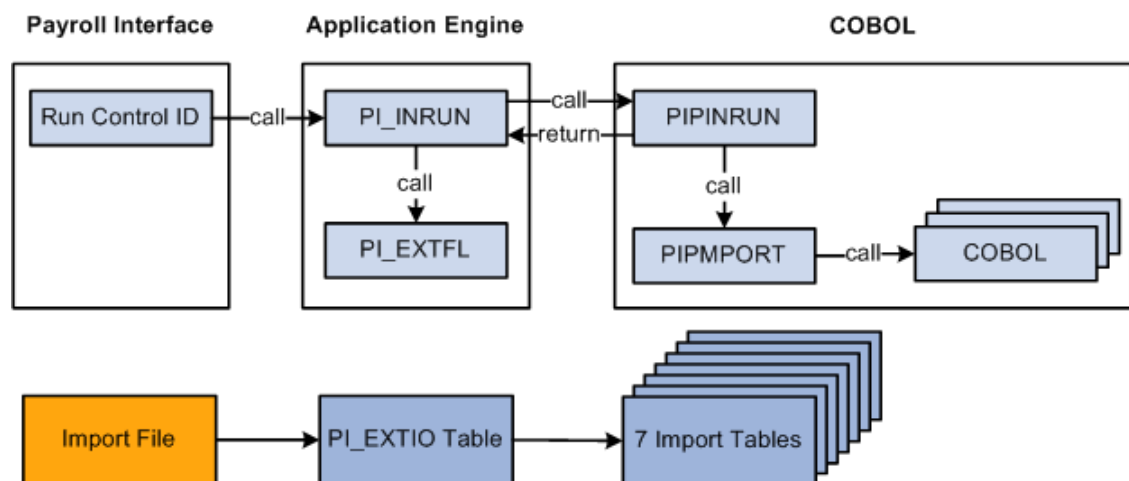

Import processing occurs in the following way:

1. To start the Import process, enter a pay run ID, run number, and other parameters using the Import/Export Payroll Data component, Import/Export Payroll Data run control page.

2. PI_INRUN reads the run control record and calls PI_EXTFL.
3. PI_EXTFL loads the import file into table PI_EXTIO and returns control to PI_INRUN.
4. PI_INRUN calls PIPINRUN.
5. PIPINRUN calls PIPMPORT (which in turn calls other subroutines).
6. PIPMPORT reads the PI_EXTIO table and loads the data into seven import tables.
7. PIPINRUN returns control to PI_INRUN.
8. PI_INRUN deletes the PI_EXTIO table and the run control.

Import Tables

Payroll Interface uses seven import tables to store the payroll results that are generated by the third-party payroll system. The import tables include many user-defined fields. You do not need to map data to all of these fields, but you do need to map to a few, such as check number and gross wages. The import tables are:

- PI_CHECK
- PI_EARN_DETAIL
- PI_DED_DETAIL
- PI_TAX_DETAIL
- PI_EARN_BAL
- PI_DED_BAL
- PI_TAX_BAL

Note

After the Import process is run, further processing or technical configuration may be required to check the validity of the data or to ensure that employee-level data can be accessed in a secure manner.

To import numeric and signed numeric fields, the data value in the import file must not contain any spaces. For example, to import a numeric field with a length of 10, decimal length of 2, display decimal enabled, and a value of 10.22, the value in the data file must equal 0000010.22 (leading zeros), and not bbbbb10.22 (where b represents a blank space).

Payroll Interface does not perform reverse translations (mappings). The data loaded into the import tables resides in the third-party payroll system's format. For example, suppose you select the *Using Interface Employee Table* option for the System Table (SYSTEM_TABLE) component, Interface System Table 1 page, Convert field. During the Export process, the PeopleSoft EMPLID is translated to the third-party payroll system employee ID, and the third-party payroll system employee ID is written to the export file or table. During the Import process, however, no reverse translation takes place. The third-party payroll system employee ID is loaded into the Payroll Interface import tables.

Note

If you select the *Using Interface Employee Table* option, the data in the Payroll Interface import tables can be joined to other PeopleSoft EMPLID-keyed tables through the PI_EMPLID_TBL table. This table includes the EMPLID, EMPL_RCD, and PI_EMPLID fields.

Related Topics

- [Setting Up the System Table](#)
To set up the System Table, use the System Table (SYSTEM_TABLE) component.

Export and Import Testing

This topic discusses:

- Testing exports and imports.
- Successful exports.
- Unsuccessful exports.
- Detecting errors.

Testing Exports and Imports

To test export and import interface definitions, run the Payroll Interface Export and Import processes until no errors occur and the data results are correct. Import interface definitions are usually set up and tested after the export interface definition is verified.

Testing Exports

To test an export interface definition the first time:

1. Delete the contents of the Payroll Interface tables shown below.
2. (optional) Run the Calculate Deductions and Confirmation processes.
3. Run a full-records Export process.
Use the Pay Run ID prior to the pay run that is to be used for production.
4. When the Export process completes, check for errors.

Delete the content of these tables before running the Export process the first time:

- PI_RUNCTL
- PI_RUN_TBL
- PI_RUN_PYGRP
- PI_PARTIC
- PI_PARTIC_EXPT
- PI_EXTIO
- PI_PARTIC_EXTBL
- PI_MESSAGE
- DED_LINE

- DED_CALC
- DED_MESSAGE

Testing Imports

To test the import interface definition the first time:

1. Delete the contents of the Payroll Interface tables shown in the succeeding table.
2. Obtain a copy of the import file that is produced by the third-party payroll system.
3. Run the Import process.
Use the pay run ID for the associated Export process.
4. When the Import process finishes, check for errors.

Delete the content of these tables before running the Import process the first time:

- PI_RUNCTL
- PI_RUN_TBL
- PI_RUN_PYGRP
- PI_MESSAGE
- PI_EXTIO
- PI_CHECK
- PI_EARN_DETAIL
- PI_DED_DETAIL
- PI_TAX_DETAIL
- PI_EARN_BAL
- PI_DED_BAL
- PI_TAX_BAL

Related Topics

- [Table Management](#)
Payroll Interface is a table-driven export and import engine. As you set up and maintain an interface definition, you may need to work directly with various Payroll Interface tables.

Successful Exports

You can identify a successful export run in the following ways:

- Changes that occurred during the pay period to PeopleSoft HCM mapped-data elements are exported and written to a file or table.
- The compare process identifies correct changes.
- The implementation of additional processing logic (beyond the delivered supported application functionality) works correctly, including:
 - Modifying the delivered Payroll Interface COBOL, for example, creating a new process ID.
 - Processing files using Application Engine, Structured Query Report (SQR), or other programming languages, for example, reformatting a record layout.

- Writing PeopleCode, for example, to force a new set of export records given a specific job action (that is, rehire or transfer).
- Creating new views, incorporating any American National Standards Institute (ANSI) SQL statement. For example, join the Department table with Job to extract department GL expense codes or managers, develop specific WHERE clauses, and perform Logic/Arithmetic/SQL functions.
- The contents of the export file (or table) are imported into the third-party payroll system and the data elements and transactions have been processed accurately per the third-party payroll system's import processing requirements. These types of transactions involve updating, inserting, or deleting employee data.

Unsuccessful Exports

For debugging purposes, sometimes it may be useful to run the PIPINRUN process directly. First, use the Import/Export Payroll Data component, Import/Export Payroll Data run control page to enter and save the Run Control ID and Pay Run ID. Then, instead of submitting the request to the process scheduler using the RUN button, run PIPINRUN at the command line of the process server or any connected computer with fully compiled current COBOL. During the run, PIPINRUN calls PIPCMPAR and PIPXPORT, the results are written to the PI_EXTIO table, and then processing stops. To rerun the PIPINRUN process, the contents of the PI_EXTIO table as well as the PI_RUNCTL table must be deleted.

Example 1

Export Result: PI_PARTIC and PI_PARTIC_EXPT are both empty.

If the failure of the export is not obvious, for example, the process terminates or a Payroll Interface error message such as MISSING RUN CONTROL is displayed, then analyze the employees. The Pay Run ID determines the pay calendar's company and pay group. PIPCMPAR selects against JOB.COMPANY and JOB.PAYGROUP to retrieve the appropriate employees. The DMS statement used in PIPCMPAR.DMS to select these employees performs an insert into PI_PARTIC. Therefore, if PI_PARTIC is empty, it is because the PIPCMPAR SQL that is trying to select employees and do the insert failed.

Most likely, an interface error message is in PI_MESSAGE stating that there were no records to export. However, to determine why no employees were selected, you will need to analyze the pay run ID, the associated pay calendar, the Pay Group table, and the corresponding employee job records.

Example 2

Export Result: PI_PARTIC is loaded and PI_PARTIC_EXPT is empty.

If the PI_PARTIC table is loaded, then the Export process select phase was successful (which means that the pay run ID, the pay calendar, the Pay Group table, and the Job records were set up correctly). If the process did not end, but the PI_PARTIC_EXPT table is empty, then the Export process compare phase was not successful. Do an inquiry on the interface messages (PI_MESSAGE) to determine why the process failed. When all of the issues are fixed, you should be able to reprocess the export.

Example 3

Export Result: PI_PARTIC is loaded, PI_PARTIC_EXPT is loaded, PI_EXTIO is loaded (when it should be empty) and no export file is created.

If PI_EXTIO is loaded, the Export process select, compare, and export phases finished successfully. However, the Application Engine's file I/O process that writes the contents of

PI_EXTIO to the export file (and then deletes PI_EXTIO) did not finish successfully. Make sure the file IDs and file handles are set up correctly. If they are, then analyze the Application Engine programs PI_INRUN and PI_EXTFL.

Note

This does not apply if you are exporting data to a table.

Example 4

Export Result: PI_PARTIC is loaded, PI_PARTIC_EXPT is loaded, PI_EXTIO is empty, and no export file is created.

This scenario could mean that the Export process was successful and no changes exist. It also could mean that the Export process was successful and the external file was created, but the file is not located where you expected it.

If known data changes have occurred and the file cannot be found, then evaluate the PSPSEQIO COBOL program for issues surrounding the insert into the PI_EXTIO table. It would be helpful to run the COBOL process separately to insure that PI_EXTIO is being loaded at the end of the compare and export phases. At that point, the analysis should shift to the Application Engine's write to the external file.

Note

This does not apply if you are exporting data to a table.

Related Topics

- [Understanding Data Exchanges](#)
Payroll Interface enables you to exchange data between PeopleSoft HCM and a third-party payroll system. Data is exported from PeopleSoft HCM to the third-party payroll system using either a file or table. Data is imported from the third-party payroll system back into PeopleSoft HCM using *only* an ASCII formatted file. You use the same run-control process to export or import data.

Detecting Errors

To determine whether an error has occurred after running the Calculate Deductions or Deduction Confirmation processes, first refer to the Review Deductions and Review Error Messages components.

See [Reviewing Deductions](#).

To determine whether an error has occurred after running the Export or Import processes, first refer to the Error Messages (PI_MESSAGES) component and various reporting components.

See [Reviewing Exports or Imports](#).

Error Messages

If the explanation in the Error Message component is not clear, you can use the message number to determine where in the COBOL routine the problem occurred. For example, suppose message 004030 returns the following information:

The Dedcalc process was not confirmed. This data is not available until the confirm is processed. The message data below identifies 2 field values. 1. Company 2. Paygroup.

To locate the problem:

1. Search for 004030 in PSCPYMSG.CBL to determine the corresponding 88 level name for MSGID.

In this case, it is MSGID-DEDCALC-NOT-CONFIRMED.

2. Using a search tool, do a search against PI*.CBL to look for all the occurrences of MSGID-DEDCALC-NOT-CONFIRMED.

The result is in PIPINRUN.CBL, paragraph MM100-CONFIRM-DEDCALC.

The location of the error in the COBOL routine may point to a SQL statement or array search that may give additional clues to the problem.

Error: Dynamic SQL Failure Due to Invalid PS Table Setup

If you use PeopleSoft Application Designer to change any of the tables or fields that are set up in the PS Tables (PS_TABLES) component, you must make sure that these changes are reflected in the PS Tables component as well. If you do not, the Export process will end when attempting to run the dynamically created SQL statement. If it is not obvious which table or field is causing the error, you can run the Export process from a DOS prompt.

To run PIPINRUN from the DOS prompt:

1. From the DOS prompt, run PIPINRUN with the SQL Trace turned on.
2. At the SQL Trace prompt, enter 191.

A trace file is written to C:\TEMP\PS\

3. Copy the SQL to the database's SQL Inquiry tool and run it using the parameters listed below the statement in the trace file.

The SQL Inquiry tool should point to the problem field.

See *PeopleTools: Application Designer Developer's Guide*

Error: Maximum Number of Export Records Exceeded for EMPLID

PIEXPT-COUNT-MAX represents the maximum number of records that can be generated for an EMPLID. During the Export process, this maximum number can be reached when you are processing files that comprise a high number of rows in PS_JOB.

PIEXPT-COUNT-MAX is set to 200 by default. If you want to increase this number, you need to modify to the COBOL in two places:

- In PICIEXPT.CBL, insert the desired number where you see 200 in bold.
88 PIEXPT-COUNT-MAX VALUE 200
- In PIPIEXPT.CBL, insert the desired number where you see 200 in bold.
02 PIEXPT-DATA OCCURS 200

Be sure to recompile the programs when you are done.

You may encounter similar error messages for "Maximum number of export records exceeded." Again, just follow the code line through and increase the 88 VALUE and the corresponding OCCURS values.

Table Management

Payroll Interface is a table-driven export and import engine. As you set up and maintain an interface definition, you may need to work directly with various Payroll Interface tables.

Note

If using PeopleSoft Data Mover to run DELETE, IMPORT, and EXPORT scripts, use the internal name for the table, for example, PI_PARTIC. If using Microsoft SQL Query Analyzer or some other non-PeopleSoft tool to run SQL statements, use the external name for the table, for example PS_PI_PARTIC.

See *PeopleTools: Data Management*

Managing the Process Tables

Occasionally, you may want to delete the data in the Payroll Interface process tables to free disk space, reduce processing times, or send a full record export file to the third-party payroll system.

Warning

PeopleSoft does not support a specific purge strategy. Back up tables before you run the SQL DELETE statement.

To purge the process tables, follow these general guidelines:

1. Stop all data input into the PeopleSoft system.
2. Run the normal daily process (usually a changes-only export run).
3. Delete the data in the selected process tables.
4. Run the normal daily process again (the system will return by default to a full-records export run).

You should delete the data in the tables whenever changes are made to the export file definition (for example, changing field characteristics such as increasing or decreasing field sizes or edit masks or adding or deleting fields from the interface definition).

The PI_PARTIC and PI_PARTIC_EXPT tables can get very large. You should monitor the size of these tables on a regular basis to ensure that Payroll Interface functions properly. You may want to archive historical data in these tables.

The PI_RUN_TBL tables contains the PI_RUN_NUM field. If you purge this table, the PI run number is reset to 1. If you do not want to reset run number, do not purge the PI_RUN_TBL or the PI_RUN_PYGRP tables. When you run the Export process, the run number will be incremented to the next number.

 **Warning**

Do not purge the PI_EMPLID_TBL if you have mapped the PeopleSoft EMPLID to the third-party payroll system employee ID.

The Payroll Interface process tables include:

- AERUNCONTROL
- PI_RUNCTL
- PI_RUNCTL_AE
- PI_RUNCTL_SID
- PI_RUN_TBL
- PI_RUN_PYGRP
- PI_PRESELECT
- PI_EMPLID_TBL
- PI_PARTIC
- PI_PARTIC_EXPT
- PI_EXTIO
- PI_PARTIC_EXTBL
- PI_MESSAGE
- DED_CALC
- DED_LINE
- DED_MESSAGE

Managing the Control Tables

Occasionally, you may want to transfer the Payroll Interface control tables (also referred to as the setup tables) from one database to another for example, when you move from a test environment to a production environment.

 **Warning**

Never copy the process tables (PI_PARTIC, PI_PARTIC_EXPT, and so on) from a test environment to a production environment. These tables are automatically populated in the production environment.

To export tables, run this script:

- SET LOG C:\TEMP\PI_EXPORT.LOG
- SET OUTPUT C:\TEMP\PI_TABLES.DAT
- EXPORT PI_SYSTEM_TBL
- EXPORT PI_SYSTEM_STAT
- EXPORT PI_SYSTEM_LANG

- EXPORT PI_PS_RECORD
- EXPORT PI_PSREC_FLD
- EXPORT PI_PS_REC_LANG
- EXPORT PI_INSTANCE_TBL
- EXPORT PI_INST_VALUE
- EXPORT PI_INSTANC_LANG
- EXPORT PI_PROCESS_TBL
- EXPORT PI_PROCESS_VAL
- EXPORT PI_PROC_TB_LANG
- EXPORT PI_PROC_VA_LANG
- EXPORT PI_FIELD_TBL
- EXPORT PI_FIELD_XLAT
- EXPORT PI_FIELD_LANG
- EXPORT PI_GROUP_TBL
- EXPORT PI_GROUP_LANG
- EXPORT PI_DEFN_FILE
- EXPORT PI_DEFN_RECORD
- EXPORT PI_DEFN_FIELD
- EXPORT PI_DEFN_F_LANG
- EXPORT PI_DEFN_R_LANG
- EXPORT PI_CONFIG_TBL
- EXPORT PI_CONFIG_FILE
- EXPORT PI_CONFIG_LANG
- EXPORT FILE_HANDLE_LNG
- EXPORT FILE_HANDLE_TBL

To import tables, run this script:

- SET LOG C:\TEMP\PI_IMPORT.LOG
- SET INPUT C:\TEMP\PI_TABLES.DAT
- REPLACE_ALL *
- SET LOG C:\TEMP\PI_IMPORT.LOG
- SET INPUT C:\TEMP\PI_TABLES.DAT
- IMPORT * IGNORE_DUPS

REPLACE_ALL *;—Deletes all data from the PeopleSoft table and replaces it with the data in your import file.

IMPORT * IGNORE_DUPS;—Leaves all data in the PeopleSoft table and loads only new rows of data. It will not replace any data already in the table. So if you have a row that exists in both the source table and the target table, no action is taken at all, even if some of the fields on that row have changed

4

Setting Up Earnings Data

Understanding Earnings

Payroll Interface does not calculate earnings. You use Payroll Interface to track and export changes to earnings data that occur during a pay period. The third-party payroll system performs the earnings calculations and the gross-to-net calculations.

Payroll Interface recognizes two earnings categories, regular earnings and additional pay. Regular earnings refers to the employee earnings that are entered on the Job Data component, for example, regular or overtime pay. Additional pay refers to employee earnings that are entered on the Additional Pay component and represents earnings that an employee is paid on a regular basis in addition to regular earnings, for example, a vehicle allowance.

Two earnings components are included with Payroll Interface, the Earnings Table (EARNINGS_TABLE) component and the Earnings Program Table (EARN_PROGRAM_TBL) component:

- The primary purpose of the earnings components is to enable you to set up the earnings codes and earnings program that are required on the Pay Group Table component, Calc Parameters (calculation parameters) page.
- A secondary purpose of the earnings components is to enable you to set up earnings codes for additional pay and to add these codes to the earnings program.

Related Topics

- [Understanding Payroll Schedules](#)
To track and export changes that occur to employee-level payroll data, you run the Payroll Interface processes at least once each pay period using the payroll schedules that you establish in PeopleSoft HCM.

Setting Up Earnings Codes and Earnings Programs

To set up earnings codes and earnings programs, use the Earnings Table (EARNINGS_TABLE) and Earnings Program Table (EARN_PROGRAM_TBL) components in PeopleSoft Payroll for North America.

Pages Used to Set Up Earnings Codes and Earnings Programs

Page Name	Definition Name	Usage
Earnings Table - General Page	EARNINGS_TABLE1	Set up earnings codes. The Payment Type, Effect on FLSA, and Eligible for Retro Pay group boxes are not used by Payroll Interface.
Earnings Program Table Page	EARN_PROGRAM_TBL	Set up the earnings program.

Understanding Earnings Codes and Earnings Programs

An earnings code defines a type of earnings, for example, maternity leave. You set up earnings codes for regular earnings as well as additional pay. To satisfy the requirements of the Pay Group Table component, Calc Parameters page, you *must* set up default earnings codes for regular, overtime, and holiday pay.

An earnings program defines a set of earning codes that is valid for one or more pay groups and the employees who belong to those pay groups. To satisfy the requirements of the Pay Group Table component, Calc Parameters page, you *must* set up a default earnings program that includes the default earnings codes for regular, overtime, and holiday pay.

Related Topics

- PeopleSoft Payroll for North America: Establishing Earnings Codes
- PeopleSoft Payroll for North America: Establishing Earnings Programs

Earnings Table - General Page

Use the Earnings Table - General page (EARNINGS_TABLE1) to set up earnings codes.

Navigation:

Set Up HCM, and then **Product Related**, and then **Payroll Interface**, and then **Earnings**, and then **Earnings Table**, and then **General**

Set Up HCM, and then **Product Related**, and then **Payroll for North America**, and then **Compensation and Earnings**, and then **Earnings Table**, and then **General**

See the PeopleSoft Payroll for North America: Earnings Table - General Page in the Payroll for North America product documentation.

The **Payment Type**, **Effect on FLSA**, and **Eligible for Retro Pay** group boxes are not used by Payroll Interface.

Note

To set up the earnings codes that are required for the Pay Group Table component, use *only* the General page (ignore the Taxes, Calculation, and Special Processes pages).

To set up earnings codes for additional pay, use the General page and, *if necessary*, the Taxes, Calculation, and Special Process pages.

Earnings Program Table Page

Use the Earnings Program Table page (EARNS_PROGRAM_TBL) to set up the earnings program.

Navigation:

Set Up HCM, and then **Product Related**, and then **Payroll Interface**, and then **Earnings**, and then **Earnings Program Table**, and then **Earnings Program Table**

Set Up HCM, and then **Product Related**, and then **Payroll for North America**, and then **Compensation and Earnings**, and then **Earnings Program Table**, and then **Earnings Program Table**

See the PeopleSoft Payroll for North America: Earnings Program Table Page in the Payroll for North America product documentation.

Setting Up and Maintaining Additional Pay

To set up and maintain additional pay, use the Additional Pay (ADDITIONAL_PAY) component.

Page Used to Set Up and Maintain Additional Pay

Page Name	Definition Name	Usage
Additional Pay Page	ADDITIONAL_PAY1	Set up and assign additional pay earnings to an employee. Specify a different department to charge for the additional pay. Change employee tax data for additional pay.

Understanding Additional Pay

Additional pay refers to earnings that an employee is paid on a regular basis in addition to regular earnings, for example, a vehicle allowance, variable compensation, or benefit credits. (Do not confuse additional pay with one-time payments, such as overtime or an expense reimbursement.)

To set up and maintain additional pay:

1. Use the Earnings Table component to set up an earnings code for the additional pay.
2. Use the Earnings Program Table component to add the earnings code to the earnings program.
3. Use the Additional Pay component to set up and assign the additional pay to an employee.

Additional Pay Page

Use the Additional Pay page (ADDITIONAL_PAY1) to set up and assign additional pay earnings to an employee.

Navigation:

Payroll Interface, and then **Update Payroll Information**, and then **Additional Pay**, and then **Additional Pay**

This example illustrates the fields and controls on the Additional Pay page (1 of 3).

Additional Pay

Kirby Torres EMP ID KU0014 Empl Record 0

Additional Pay Find | View All First 1 of 4 Last

'Earnings Code C01 General Credits

Effective Date Find | View All First 1 of 1 Last

Effective Date 01/02/1999

Payment Details Find | View All First 1 of 1 Last

'Addl Seq Nbr 1 End Date

Rate Code Reason Benefits Administration Credit

Earnings \$102.31

Hours Hourly Rate

Goal Amount Goal Balance

Sep Check Nbr

Disable Direct Deposit

OK to Pay Prorate Additional Pay

Applies To Pay Periods

First Second Third Fourth Fifth

Job Information

Tax Information

This example illustrates the fields and controls on the Additional Pay page (2 of 3).

Job Information

Employee Type Hourly Standard Hours 40.00

Compensation Rate \$1,000.000000 Frequency Biweekly

Default Job Data

Position 19000042

Business Unit GBIBU Global Business Institute BU

Department 55000 Lab Facility

Job Code 660030 Nurse-Registered-ICU

Combination Code

GL Pay Type

Shift Not Applicable

Job Data Override

Position

Business Unit

Department

Job Code

Combination Code [Edit ChartFields](#)

GL Pay Type

'Addl Shift Use Job Shift

This example illustrates the fields and controls on the Additional Pay page (3 of 3).

▼ Tax Information

State

Tax Periods

Locality

*Tax Method

*Tax Frequency

*Benefit Deductions Taken

Benefit Ded Subset ID

*General Deductions Taken

General Ded Subset ID

Specify a different department to charge for the additional pay. Change employee tax data for additional pay.

Field or Control	Description
Addl Seq Nbr (additional sequence number)	Select <i>1</i> unless there are multiple additional pay records.
Earnings, Hours, and Hourly Rate	Select to indicate whether additional pay is hours multiplied by an hourly rate or a fixed amount, but not both. If an hourly rate is indicated, but the field is left blank, information is automatically populated from the employee's job record.
Goal Amount	Select to have your payroll system stop issuing this additional pay when the amount has been reached.

Applies to Pay Periods

Field or Control	Description
First, Second, Third, Fourth, and Fifth	Select the appropriate options to indicate the pay periods in which this additional pay should be identified in your payroll system. For example, if an employee were paid twice a month, but received a monthly car allowance, you would select either <i>First</i> or <i>Second</i> , but not both.

Job Data Override

Use the Job Data Override group box to change the department that is charged for the additional pay.

Field or Control	Description
Position, Business Unit, Department, Job Code, Combination Code, and GL Pay Type	Enter data in any of these fields to override the default value.
Addl Shift (additional pay shift)	Select <i>Use Job</i> to use the shift that is specified on the employee's Job record.

Tax Information

Use the Tax Information group box to modify the employee's state and local tax data.

Field or Control	Description
State	Select to enter the state that the employee worked in, if different from the employee's regular pay. This field is validated against the employee's state and local tax data.
Locality	Select to enter the locality that the employee worked in, if different from the employee's regular pay. This field is validated against the employee's state and local tax data.

5

Setting Up Deduction Data

Understanding Deductions

Payroll Interface recognizes two types of deductions: benefit deductions and general (non-benefit) deductions. Benefit deductions are deductions that are associated with benefit programs, and include deductions for health plans, life insurance plans, and other benefit plans. General deductions are deductions that typically are not associated with benefits, and include deductions such as parking fees, and union dues.

You can set up and maintain deductions using Payroll Interface and the Manage Base Benefits business process in PeopleSoft HR; or, alternatively, you can have the third-party payroll system manage deductions.

Note

To simplify data entry, conversion, and maintenance issues, you may want to have the third-party payroll system manage deductions. Certain types of deductions, such as garnishments, are highly confidential and are almost always maintained in the third-party payroll system.

Related Topics

- [PeopleSoft Human Resources Manage Base Benefits](#)

Setting Up the Deduction Table

To set up the Deduction Table, use the Deduction Table (DEDUCTION_TABLE) component.

Pages Used to Set Up the Deduction Table

Page Name	Definition Name	Usage
Deduction Table - Setup Page	DEDUCTION_TABLE1	Set up deduction parameters.
Deduction Table - Tax Class Page	DEDUCTION_TABLE2	Set up deduction tax classifications.
Deduction Table - Process Page	DEDUCTION_TABLE4	Set up deduction processing.
Deduction Table - Schedule Page	DEDUCTION_TABLE5	Set up deduction schedules.

Understanding the Deduction Table

The Deduction Table component enables you to select a plan type, enter a deduction code, and set up the deduction processing rules that enable you to specify processing details such

as deduction priorities, deduction tax classifications, deduction pay period schedules, and other special payroll process indicators.

Whether you are setting up a benefit deduction or a general deduction, you begin with the Deduction Table component. For example:

- To set up a medical deduction, you would (1) use the Deduction Table component to select a plan type (Medical), enter a deduction code, and set up the deduction processing rules and (2) use components in the Manage Base Benefits business process to set up the benefit plans, benefit programs, and other deduction calculation parameters.
- To set up a 50.00 USD general deduction for parking, you would (1) use the Deduction Table component to select a plan type (General Deduction), enter a deduction code, and set up the deduction processing rules and (2) use the General Deduction Table (GENL_DEDUCTION_TBL) component to enter the dollar amount and other deduction calculation parameters.

The plan type that you select is critical in the deduction process because it indicates to the system whether you are setting up a deduction code for a benefit deduction or a general deduction. It also indicates to the system from which component, the Benefit Program Table (BEN_PROG_DEFN) component or the General Deduction Table component, to retrieve the deduction calculation parameters.

This graphic illustrates the relationship between the Deduction Table component, benefit deductions, and general deductions:

This diagram illustrates the relationship between the Deduction Table component, benefit deductions, and general deductions.

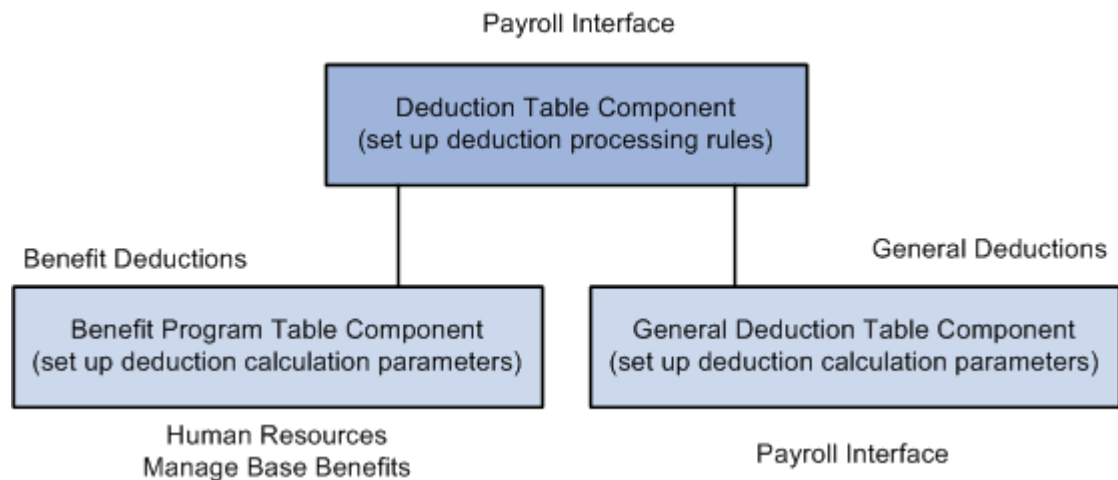

Deduction Table - Setup Page

Use the Deduction Table -Setup page (DEDUCTION_TABLE1) to set up deduction parameters.

Navigation:

Set Up HCM, and then **Product Related**, and then **Payroll Interface**, and then **Deductions**, and then **Deduction Table**, and then **Setup**

This example illustrates the fields and controls on the Deduction Table - Setup page.

Setup | Tax Class | Tax Effect | Process | Schedule

Plan Type 00 General Deduction **Deduction Code** B00-09

Deduction Information Find First 1 of 1 Last

'Effective Date 01/01/1980 + -
 'Description Credit Union
 Short Description CU
 Deduction Priority 500
 Special Processing v

Maximum Arrears Payback

No Maximum
 Flat Maximum for Payback _____
 Factor x Regular Deduction _____

Deduction Subset Find | View All First 1 of 1 Last

'Subset ID	Description
[]	

Field or Control	Description
Deduction Code	Set up deduction codes that mirror the deduction codes in the third-party payroll system.
Deduction Priority	Not used by Payroll Interface; however, you can set up deduction priorities that mirror the deduction priorities in the third-party payroll system.

Note

The Maximum Arrears Payback group box and Deduction Subset group box are not used by Payroll Interface.

Deduction Table - Tax Class Page

Use the Deduction Table - Tax Class page (DEDUCTION_TABLE2) to set up deduction tax classifications.

Navigation:

Set Up HCM, and then **Product Related**, and then **Payroll Interface**, and then **Deductions**, and then **Deduction Table**, and then **Tax Class**

This example illustrates the fields and controls on the Deduction Table - Tax Class page.

Setup Tax Class Tax Effect Process Schedule

Plan Type 00 General Deduction
Deduction Code B00-09 Credit Union

Deduction Information Find First 1 of 1 Last

Effective Date 01/01/1980

Tax Classifications Find | View All First 1 of 1 Last

Deduction Classification

- After-Tax
- Before-Tax
- Nontaxable Benefit
- Nontaxable Btax Benefit
- Taxable Benefit
- QC Taxable Benefit

Canadian Sales Tax

- None
- Goods and Services Tax
- Harmonized Sales Tax
- Provincial Sales Tax
- Provincial Sales Tax Insurance
- Provincial Premium Tax

Special Accumulator(s) Find | View All First 1 of 1 Last

'Accumulator' 'Effect on Special Balance' Adds to Special Balance

Deduction Classification

Use this group box to select an appropriate tax classification for the deduction, including:

- *After-tax* or *before-tax* for employee deductions.
- *Nontaxable benefit* and *nontaxable before-tax benefit* for employer contributions.

A deduction can have more than one classification. However, it is still considered one deduction. For example, a benefit deduction plan, such as 401(k), can have both before-tax and after-tax classifications as well as a nontaxable classification for employer contributions.

Note

(USF) A retirement plan deduction, such as TSP benefit deductions, can have a before-tax and a nontaxable classification for any employer contributions. Certain benefits, such as FEGLI, will have an after-tax classification for the employee contribution. If your agency has a FEGLI plan that provides coverage in an amount equal to three times your base salary of 40,000 USD a year, you pay for the after-tax deduction.

Field or Control	Description
After-Tax	Select to reduce net pay. An example is a monthly parking deduction.
Before-Tax	Select to reduce net pay and taxable gross. An example is an employee contribution to a retirement program, such as a 401(k) plan.
Nontaxable Benefit	Select to represent an employer contribution (not subject to federal tax) to an employee benefit plan, such as a health plan or retirement plan. The contribution has no payroll effect. The after-tax matching contribution for savings plans is a nontaxable benefit.

Field or Control	Description
Nontaxable Btax Benefit (nontaxable before-tax benefit)	Select to represent an employer contribution (not subject to federal tax) to an employee benefit plan. Currently used only for the before-tax matching contribution to savings plans.
Taxable Benefit	Select to represent an employer contribution (subject to federal tax) to an employee benefit plan, such as life insurance. The contribution increases federal withholding taxable gross (for tax purposes) but does not increase total gross (for pay purposes).

Deduction Table - Process Page

Use the Deduction Table - Process page (DEDUCTION_TABLE4) to set up deduction processing.

Navigation:

Set Up HCM, and then **Product Related**, and then **Payroll Interface**, and then **Deductions**, and then **Deduction Table**, and then **Process**

This example illustrates the fields and controls on the Deduction Table - Process page.

Process Information

Use this group box to define parameters for deductions during deduction processing.

Field or Control	Description
Partial Deduction Allowed	Not used by Payroll Interface.

Field or Control	Description
Deduction Arrears Allowed	Not used by Payroll Interface.
Deductions Taken From Sep Chk (deductions taken from separate check)	Not used by Payroll Interface.
Stop Deduction at Termination	For each deduction classification, select this option to stop the deduction for a terminated employee. For example, most health insurance plans are prepaid; premiums deducted for the current month are used to provide coverage for the next month. If an employee is terminated and no longer has health benefits, the deduction should not be taken.
Liability Accounts - Non Commitment Accounting	Not used by Payroll Interface. However, you may enter general ledger account numbers for your own information.

Deduction Table - Schedule Page

Use the Deduction Table - Schedule page (DEDUCTION_TABLE5) to set up deduction processing.

Navigation:

Set Up HCM, and then **Product Related**, and then **Payroll Interface**, and then **Deductions**, and then **Deduction Table**, and then **Schedule**

This example illustrates the fields and controls on the Deduction Table - Schedule page.

Setup
Tax Class
Tax Effect
Process
Schedule

Plan Type 00 General Deduction

Deduction Code B00-09 Credit Union

Deduction Information
Find
First 1 of 1 Last

Effective Date 01/01/1980 + -

Deduction Schedule
Find | View All
First 1-2 of 2 Last

***Pay Frequency** B Biweekly + -

Deduction Frequency

First Pay Period Second Pay Period Third Pay Period

Fourth Pay Period Fifth Pay Period

***Pay Frequency** S Semimnthly + -

Deduction Frequency

First Pay Period Second Pay Period Third Pay Period

Fourth Pay Period Fifth Pay Period

Deduction Schedule

By default, deductions are taken out every pay period regardless of pay frequency. Use this group box if you want a deduction to be taken out on a schedule other than every pay period.

Field or Control	Description
Pay Frequency	<p>Select the pay frequency that you want to override for those deductions that are not deducted every pay period. Values prompt from the Frequency table: <i>Annual, Biweekly, Daily, Monthly, Quarterly, Semimonthly, and Weekly</i>.</p> <p>If you select a weekly frequency, you can select the Fifth Pay Period option only if you have also selected the first, second, third, and fourth pay period options. Likewise, if you select a biweekly frequency, you can select only the Third Pay Period option if you have also selected the first and second pay period options.</p> <p>Because a deduction with a monthly frequency is always taken once a month, no override is available for a monthly frequency. Suppose you have a semimonthly payroll, but a health deduction should only come out of the last paycheck of the month. In this case, you would select a pay frequency of <i>Semimonthly</i> and take a deduction in the second pay period.</p>

Deduction Frequency

Use this group box to specify the appropriate pay periods in which to take the deduction for the selected pay frequency. You must insert a new row for every pay frequency for which you have a pay group defined.

Field or Control	Description
First Pay Period through Fifth Pay Period	Select the appropriate pay periods that you want the deduction to be taken in.

Viewing Benefit Deductions

To view benefit deductions, use the Benefit Program (BEN_PROG_DEFN) component.

Pages Used to View Benefit Deductions

Page Name	Definition Name	Usage
Benefit Program Page	BEN_PROG_DEFN1	View a benefit program.
Assign to Benefit Program Page	BEN_PROG_PARTICPTN	View the benefit programs in which an employee is enrolled.

Understanding Benefit Deductions

Benefit deductions are set up using Payroll Interface and the Manage Base Benefits business process. To set up benefit deductions:

1. Use the Deduction Table component in Payroll Interface to select the plan type (any plan type except General Deduction), enter a deduction code, and set up the deduction processing rules.

See [Setting Up the Deduction Table](#).

2. Use the Benefit Plan Table (BENEFIT_PLAN_TABLE) component and other components in the Manage Base Benefits business process to set up benefit plans.

See PeopleSoft Human Resources Manage Base Benefits: Defining Benefit Plans.

3. Use the Benefit Program Table component and other components in the Manage Base Benefits business process to build the benefit program and to define the deduction calculation parameters.

See PeopleSoft Human Resources Manage Base Benefits: Understanding Benefit Programs.

Benefit plans and programs are set up using the Manage Base Benefits business process; however, as a convenience, two components are duplicated in Payroll Interface: the Benefit Program component and the Assign to Benefit Program component. You can use these components as quick references when testing the interface definitions or trouble shooting deduction-related issues.

Calculating Benefit Deductions

Payroll Interface calculates pay period benefit deductions. When you run the Calculate Deductions and Deduction Confirmation processes, the calculated benefit deduction amounts are written to the export file. The third-party payroll system performs all gross-to-net-calculations.

See [Calculating Deductions](#).

Benefit Program Page

Use the Benefit Program page (BEN_PROG_DEFN1) to view a benefit program.

Navigation:

Set Up HCM, and then **Product Related**, and then **Payroll Interface**, and then **Benefit Program**, and then **Benefit Program**

This example illustrates the fields and controls on the Benefit Program page.

Benefit Program	Plan Type and Option	Cost
Benefit Program	KU1	
Effective Date	01/01/2005	
Description	GBI US Fulltime Benefit Pgm	
Short Description	GBI US FT	
Status as of Effective Date	Active	
Program Type	Automated	
Currency Code	USD	
COBRA	Benefits Administration	
COBRA Surcharge %	2	
COBRA Disabled Surcharge %	50	
COBRA Contact ID		
Apply Excess Credits to	Cash	
FSA	Self-Service Configuration	
Flexible Spending Acct Run ID	KU1 FSA US	
FSA Maximum Annual Pledge	7000.00	
<input checked="" type="checkbox"/> Show Credits on Enrollment Form <input type="checkbox"/> Include Can Sales Tax on Form <input type="checkbox"/> Show Employer Costs on Form <input type="checkbox"/> Alert to Tax Impacts on Form	Cost Freq on Enrollment Form: Annual Frequency Handbook URL ID:	
FMLA	FMLA Plan ID: KUF Roll-Fwd	

Assign to Benefit Program Page

Use the Assign to Benefit Program page (BEN_PROG_PARTICPTN) to view the benefit programs in which an employee is enrolled.

Navigation:

Payroll Interface, and then **Assign to Benefit Program**, and then **Assign to Benefit Program**

This example illustrates the fields and controls on the Assign to Benefit Program page.

Assign to Benefit Program

Olivia Andrews Employee ID B-BARET201 Benefit Record Number 0

Benefit Program Participation Find | View All First 1 of 1 Last

Effective Date 04/01/1997

Benefit Program B46 BAS Retro Regression Currency Code USD

Setting Up and Maintaining General Deductions

To set up and maintain general deductions, use the Deduction Table (DEDUCTION_TABLE) and General Deduction Table (GENL_DEDUCTION_TBL) components.

Pages Used to Set Up and Maintain General Deductions

Page Name	Definition Name	Usage
Deduction Table - Setup Page	DEDUCTION_TABLE1	Set up the plan type (00 — General Deduction) and deduction code.
General Deduction Table Page	GENL_DEDUCTION_TBL	Set up a general deduction and define the deduction calculation parameters. For the matching entry on the Deduction Table component, select the plan type (00 — General Deduction).
General Deduction Page	GENL_DED_DATA	Assign a general deduction to an employee.
Overriding General Deductions Page	GENL_DED_OVERRIDE	Override a general deduction that is assigned to an employee.

Understanding General Deductions

General deductions are set up using Payroll Interface. To set up general deductions:

1. Use the Deduction Table component to select the plan type (General Deduction), enter a deduction code, and set up the deduction processing rules.
See [Setting Up the Deduction Table](#).
2. Use the General Deduction Table component to set up the general deduction and to define the deduction calculation parameters.
3. Use the General Deduction component to assign a general deduction to an employee.
4. Use the Override General Deductions component to override a general deduction assignment.

Exporting General Deductions

Payroll Interface does not calculate general deductions. However, when you run the Calculate Deductions and Deduction Confirmation processes, general deductions are automatically processed and the general deduction flat amounts are written to the export file along with the calculated benefit deduction amounts. If you do not maintain benefit deductions (do not run the Calculate Deductions process), you can set up and export general deduction amounts separately through the interface definition.

See [Understanding Deduction Processing](#).

Deduction Table - Setup Page

Use the Deduction Table - Setup page (DEDUCTION_TABLE1) to set up the plan type (00 — General Deduction) and deduction code.

Navigation:

Set Up HCM, and then **Product Related**, and then **Payroll Interface**, and then **Deductions**, and then **Deduction Table**, and then **Setup**

This example illustrates the fields and controls on the Deduction Table - Setup page.

Plan Type 00 General Deduction Deduction Code B00-09

Deduction Information Find First 1 of 1 Last

*Effective Date 01/01/1980

*Description Credit Union

Short Description CU

Deduction Priority 500

Special Processing

Maximum Arrears Payback

No Maximum
 Flat Maximum for Payback
 Factor x Regular Deduction

Deduction Subset Find View All First 1 of 1 Last

Subset ID	Description

General Deduction Table Page

Use the General Deduction Table page (GENL_DEDUCTION_TBL) to set up a general deduction and define the deduction calculation parameters.

Navigation:

Set Up HCM, and then **Product Related**, and then **Payroll Interface**, and then **Deductions**, and then **General Deduction Table**, and then **General Deduction Table**

This example illustrates the fields and controls on the General Deduction Table page.

General Deduction Table

Deduction Code KCPARK Parking

General Deduction Find View All First 1 of 1 Last

*Effective Date 01/01/1980

*Deduction Calculation Routine Flat Amount

Deduction Rate or %

Special Accumulator Code

Set ID SHARE

Vendor ID CANKC00008 Imperial Parking

Pay Mode S Pay at Specified Date

AP Payment Date Type Check Date

Loan Processing (Canada)
 Ben Admin Taxable Ben (Canada)
 Allow Update Via Self Service

Amount Per Pay Period Find View All First 1 of 4 Last

Flat/Additional Amount \$40.00

*Pay Frequency B Biweekly

Field or Control	Description
Deduction Calculation Routine	<p>Select to enter the deduction calculation routine. For Payroll Interface, the only valid routines are <i>Flat Amount</i> and <i>Special Deduction Calculation</i>.</p> <p>If you select <i>Flat Amount</i>, enter the amount in the Flat/Additional Amount field for each pay frequency that your company uses. If the amount varies from employee to employee, such as with United Way or other charitable contributions, leave the Flat/Additional Amount field blank. This information can be maintained at the employee level on the General Deduction page.</p> <p>If you use a deduction rate, you can also enter an amount to be deducted. However, you need to indicate the amount here only if it is the same for all employees within a pay frequency. If it varies from employee to employee, you enter the amounts for each employee on the General Deduction page.</p>
Deduction Rate or %	<p>Select to enter the deduction rate or percentage. This value can be overridden at the employee level.</p>
Pay Frequency	<p>Select to add new rows as necessary. For example, to set up a 50 USD per month parking deduction, you could create two rows: one for a semimonthly pay frequency with 25.00 USD to be taken every pay period and the other for a monthly pay frequency with 50 USD. (Note that when you select this option, the Deduction Rate box is not available.)</p> <p>For a deduction that varies by frequency, you must indicate the amount to be taken each pay period for <i>each</i> frequency. For the 50 USD per month parking deduction, you can set up the deduction for the semimonthly pay group, SM1, so that it applies only to the last pay period of the month. Rather than taking out 25 USD each pay frequency, you take the full 50 USD at the end of the month. To set this up, you need to indicate both the frequency and amount. Set the frequency as semimonthly and enter 50.00 USD. Indicate which semimonthly period to take the deduction for SM1 on the Deduction Table.</p>

General Deduction Page

Use the General Deduction page (GENL_DED_DATA) to assign a general deduction to an employee.

Navigation:

Payroll Interface, and then **Update Payroll Information**, and then **General Deduction**, and then **General Deduction**

This example illustrates the fields and controls on the General Deduction page.

General Deduction

Arthuro Erickson

Person ID KU0006

Company GBI Global Business Institute

Field or Control	Description
Calculation Routine	Select how a deduction is calculated for an employee. If you do not make a selection, the deduction is calculated according to the Deduction Table. These routines are identical to the routines on the General Deduction Table. Choose from the following: <i>Default to Deduction Table:</i> Uses the calculation routine that is specified on the Deduction Table. The <i>Flat/Addl Amount</i> field and <i>Deduction Rate or %</i> field on this page are not used. The system uses only values that are entered on the Deduction Table. <i>Flat Amount:</i> Establishes the deduction as a flat amount. Enter the amount in the <i>Flat/Addl Amount</i> field, which is treated as an amount per pay period. The <i>Deduction Rate or %</i> field is not used.
Ded stopped by Self Serv User (deduction stopped by self-service user)	Select when an employee has stopped a voluntary deduction through a self-service application.
Deduction End Date	Select to specify when a deduction should no longer be taken.

Overriding General Deductions Page

Use the Override General Deductions page (GENL_DED_OVERRIDE) to override a general deduction that is assigned to an employee.

Navigation:

Payroll Interface, and then **Update Payroll Information**, and then **General Deduction Override**, and then **Override General Deductions**

This example illustrates the fields and controls on the Override General Deductions page.

Override General Deductions

Arthur Erickson

EMP

ID KU0006

Empl Record 0

Company GBI Global Business Institute

Pay Group KU3 US Semi-Monthly

Deduction Override Settings Find | View All First 1 of 1 Last

Deduction Code  Parking + -

Deduction Taken In

- First Pay Period
- Second Pay Period
- Third Pay Period
- Fourth Pay Period
- Fifth Pay Period

Arrears Payback

Maximum

Maximum Amount

6

Setting Up Tax Data

Understanding Tax Data

Payroll Interface does not calculate taxes. You use Payroll Interface to track and export changes to tax data (primarily W4 withholding information) that occur during a pay period. The third-party payroll system performs all gross-to-net calculations.

To set up tax information correctly, you must understand the data mappings between PeopleSoft HCM and the third-party payroll system. You generally want to export some type of code or numeric value. If an employee works for multiple companies, then you must set up tax data for each company.

Note

To simplify data entry, conversion, and maintenance issues, you may want to have the third-party payroll system manage all tax information.

Tax Location Data

The Tax Location Table (TAX_LOCATION_TBL) component enables you to establish a tax location ID and to identify the work states, provinces, and localities that are associated with each tax location.

Note

If you've selected the **Automatic Employee Tax Data** option on the Application Fundamentals: Product Specific Page of the Installation Table (INSTALLATION_TBL) component, PeopleSoft automatically sets up tax data for each work and resident state and locality of each of your employees. Tax distribution records are created for the work state or locality if the tax location represents a single state or locality.

Note that if the **Use State Residence for Local** option is selected, the system does not select the **Resident** check box automatically on the newly added local tax data row when 1) an employee transfers to a different work location in the same resident state, or 2) a new employment instance is added for a different work location in the same resident state. Refer to the PeopleSoft Payroll for North America: Understanding Resident Locality in Local Tax Data section for more information.

Tax Distribution Data

Every employee must have at least one Tax Distribution record. The system automatically populates the **State**, **Province**, and **Locality** fields from the **Tax Location** field on the employee's Job Data record. The state and locality codes come from the Tax Location table.

Employee Tax Data

You will use the Employee Tax Data pages to enter and maintain federal, state, and local tax data for each of your employees.

Note

If you've selected the **Automatic Employee Tax Data** option on the Application Fundamentals: Product Specific Page of the Installation Table component, PeopleSoft automatically sets up employee tax and tax distribution data when an employee is hired, transfers to another company, or changes jobs.

Note that if the **Use State Residence for Local** option is selected, the system does not select the **Resident** check box automatically on the newly added local tax data row when 1) an employee transfers to a different work location in the same resident state, or 2) a new employment instance is added for a different work location in the same resident state. Refer to the PeopleSoft Payroll for North America: Understanding Resident Locality in Local Tax Data section for more information.

You can run SQR TAX016, the Default Tax Data Report, to verify automatically created tax data. This report tells you, within the date range that you specify, which employees have default data on their tax records.

Related Topics

- [PeopleSoft Payroll Interface Reports: A to Z](#)
Tables in this topic list PeopleSoft Payroll Interface reports, sorted by report ID.

Setting Up Tax Location Data

To set up tax locations, use the Tax Location Table (TAX_LOCATION_TBL) component.

Tax locations are discussed in the *PeopleSoft HCM Application Fundamentals* product documentation.

Related Topics

- Application Fundamentals: Defining Tax Locations

(CAN) (USA) Setting Up Company Tax Data

To set up company tax data, use the Company State Tax Table (CO_STATE_TAX_TBL), Company Local Tax Table (COMP_LOCAL_TAX_TBL), and Company Tax Table CAN (CO_CAN_TAX_TABLE) components.

Company tax data is discussed in the *PeopleSoft HCM Application Fundamentals* product documentation.

Related Topics

- Application Fundamentals: (USA) Setting Up the Company State Tax Table
- Application Fundamentals: (USA) Setting Up the Company Local Tax Table
- Application Fundamentals: (CAN) Setting Up the Canadian Company Tax Table

(CAN) (USA) Setting Up and Maintaining Tax Distribution Data

Use the Update Tax Distribution component in Payroll for North America to set up and maintain USA and CAN tax distribution data.

Related Topics

- PeopleSoft Payroll for North America: Entering Tax Distribution Information

Pages Used to Set Up and Maintain Tax Distribution Data (USA and CAN)

Page Name	Definition Name	Usage
Update Tax Distribution Page	TAX_DISTRIBUTION	(USA) Set up and maintain, for salaried or exempt hourly employees only, a percentage for each U.S. state or locality in which an employee consistently works.
Update Tax Distribution Page	TAX_DIST_CAN	(CAN) Enter the tax distribution information for Canadian employees.

Update Tax Distribution Page

(USA, USF) Use the Update Tax Distribution page (TAX_DISTRIBUTION) to set up and maintain, for salaried or exempt hourly employees only, a percentage for each U.S. state or locality in which an employee consistently works.

Navigation:

Payroll Interface, and then **Update Payroll Information**, and then **Tax Distribution USA**, and then **Update Tax Distribution**

Payroll for North America, and then **Employee Pay Data USA**, and then **Tax Information**, and then **Update Tax Distribution**, and then **Update Tax Distribution**

Payroll for North America, and then **Employee Pay Data USF**, and then **Tax Information**, and then **Update Tax Distribution**, and then **Update Tax Distribution**

See the PeopleSoft Payroll for North America: Update Tax Distribution Page for USA in Payroll for North America product documentation.

Update Tax Distribution Page

(CAN) Use the Update Tax Distribution page (TAX_DIST_CAN) to enter the tax distribution information for Canadian employees.

Navigation:

Payroll Interface, and then **Update Payroll Information**, and then **Tax Distribution CAN**, and then **Update Tax Distribution**

Payroll for North America, and then **Employee Pay Data CAN**, and then **Tax Information**, and then **Update Tax Distribution**, and then **Update Tax Distribution**

Note

All fields on this page have the same functionality as the fields on the U.S. version of the page except for the following fields.

See the PeopleSoft Payroll for North America: Update Tax Distribution Page for CAN in Payroll for North America product documentation.

Field or Control	Description
Province	Canada doesn't allow distribution to more than one province. Select the province in which the employee works.
Percent of Distribution	Enter the tax distribution percentage for the province. For Canadian payroll, the distribution percent must be 100 for a single row. The default value is 100.

(USA) Setting Up and Maintaining U.S. Employee Tax Data

Use the Employee Tax Data USA component to maintain USA employee tax data.

Related Topics

- PeopleSoft Payroll for North America: (USA) Entering U.S. Employee Tax Data

Pages Used to Set Up and Maintain U.S. Employee Tax Data

Page Name	Definition Name	Usage
Federal Tax Data Page	TAX_DATA1	Set up employee federal tax data.
State Tax Data Page	TAX_DATA3	Set up employee state tax data.
Local Tax Data Page	TAX_DATA5	Set up tax data for each locality where an employee works.

Federal Tax Data Page

(USA) Use the Federal Tax Data page (TAX_DATA1) to set up employee federal tax data.

Navigation:

Payroll Interface, and then **Update Payroll Information**, and then **Employee Tax Data USA**, and then **Federal Tax Data**

Payroll for North America, and then **Employee Pay Data USA**, and then **Tax Information**, and then **Update Employee Tax Data**, and then **Federal Tax Data**

See the PeopleSoft Payroll for North America: Federal Tax Data Page in the PeopleSoft Payroll for North America product documentation.

State Tax Data Page

(USA) Use the State Tax Data page (TAX_DATA3) to set up employee state tax data.

Navigation:

Payroll Interface, and then **Update Payroll Information**, and then **Employee Tax Data USA**, and then **State Tax Data**

Payroll for North America, and then **Employee Pay Data USA**, and then **Tax Information**, and then **Update Employee Tax Data**, and then **State Tax Data**

See the PeopleSoft Payroll for North America: State Tax Data Page in the PeopleSoft Payroll for North America product documentation.

Local Tax Data Page

(USA) Use the Local Tax Data page (TAX_DATA5) to set up tax data for each locality where an employee works.

Navigation:

Payroll Interface, and then **Update Payroll Information**, and then **Employee Tax Data USA**, and then **Local Tax Data**

Payroll for North America, and then **Employee Pay Data USA**, and then **Tax Information**, and then **Update Employee Tax Data**, and then **Local Tax Data**

See the PeopleSoft Payroll for North America: Local Tax Data Page in the PeopleSoft Payroll for North America product documentation.

(CAN) Setting Up and Maintaining Canadian Employee Tax Data

Use the Update Employee Tax Data component in Payroll for North America to set up and maintain CAN employee tax data.

Related Topics

- [PeopleSoft Payroll for North America: \(CAN\) Entering and Maintaining Canadian Income Tax Data](#)

Pages Used to Set Up and Maintain Canadian Employee Tax Data

Page Name	Definition Name	Usage
Canadian Income Tax Data Page	TAX_DATA_CAN1	Set up Canadian income tax data.
Quebec Income Tax Data Page	TAX_DATA_CAN3	Set up Quebec income tax data.
Provincial Income Tax Data Page	TAX_DATA_CAN4	Set up provincial income tax data.

Canadian Income Tax Data Page

(CAN) Use the Canadian Income Tax Data page (TAX_DATA_CAN1) to set up Canadian Income Tax (CIT), including specifying special CIT withholding status, TD1 exemptions and adjustments, and other tax credits.

Navigation:

Payroll Interface, and then **Update Payroll Information**, and then **Employee Tax Data CAN**, and then **Canadian Income Tax Data**

Payroll for North America, and then **Employee Pay Data CAN**, and then **Tax Information**, and then **Update Employee Tax Data**, and then **Canadian Income Tax Data**

See the PeopleSoft Payroll for North America: Canadian Income Tax Data Page in the PeopleSoft Payroll for North America product documentation.

Quebec Income Tax Data Page

(CAN) Use the Quebec Income Tax Data page (TAX_DATA_CAN3) to enter QIT withholding status, exemption, and tax credit information for employees based in Quebec.

Navigation:

Payroll Interface, and then **Update Payroll Information**, and then **Employee Tax Data CAN**, and then **Quebec Income Tax Data**

Payroll for North America, and then **Employee Pay Data CAN**, and then **Tax Information**, and then **Update Employee Tax Data**, and then **Quebec Income Tax Data**

See the PeopleSoft Payroll for North America: Quebec Income Tax Data Page in the PeopleSoft Payroll for North America product documentation.

Provincial Income Tax Data Page

(CAN) Use the Provincial Income Tax Data page (TAX_DATA_CAN4) to enter provincial TD1 personal tax credit amounts.

Navigation:

Payroll Interface, and then **Update Payroll Information**, and then **Employee Tax Data CAN**, and then **Provincial Income Tax Data**

Payroll for North America, and then **Employee Pay Data CAN**, and then **Tax Information**, and then **Update Employee Tax Data**, and then **Provincial Income Tax Data**

See the PeopleSoft Payroll for North America: Provincial Income Tax Data Page in the PeopleSoft Payroll for North America product documentation.

7

Setting Up Payroll Schedules

Understanding Payroll Schedules

To track and export changes that occur to employee-level payroll data, you run the Payroll Interface processes at least once each pay period using the payroll schedules that you establish in PeopleSoft HCM.

Payroll schedules consist of pay groups and pay calendars. Pay groups tell the system which employees to process. Pay calendars tell the system when to process these employees.

To enable payroll scheduling, perform these tasks:

1. Set up the pay groups.
2. Set up a balance ID—required for pay calendars.
3. Set up a pay run ID—required for pay calendars.
4. Set up the pay calendars.

Note

Set up your pay groups and pay calendars following the requirements of the third-party payroll system. The payroll schedules that you use to run the Payroll Interface processes should coincide with the payroll schedules that are used by the third-party payroll system.

Setting Up Pay Groups

To set up pay groups, use the Pay Group Table (PAYGROUP_TABLE) component.

Pages Used to Set Up Pay Groups

Page Name	Definition Name	Usage
Pay Group Table - Definition Page	PAYGROUP_TABLE1	Set up a pay group and its basic characteristics. Enter the PI configuration ID.
Process Control Page	PAYGROUP_TABLE2	Set up process controls and establish default employee types.
Calc Parameters Page	PAYGROUP_TABLE3	Set up other processing parameters for pay groups.

Page Name	Definition Name	Usage
Paysheets Page	PAYGROUP_TABLE4	Set up the proration rules and paysheet options for each pay group that you establish. This page is used rarely by Payroll Interface.
Check Distribution Page	PAYGROUP_TABLE5	Set up the order in which you want to sort paychecks and to select address and delivery options. This page is used rarely by Payroll Interface.
Check Sequencing Page	PAYGROUP_TABLE6	Set up print sequence options. This page is used rarely by Payroll Interface.
Report Parameters Page	PAYGROUP_TABLE7	Define other report parameters for pay groups. This page is used rarely by Payroll Interface.
Bank/Tip Info Page (Bank/Tip Information)	PAYGROUP_TABLE8	Set up the bank from which employees are to be paid. Enter the source bank ID.
Time and Labor Page	PAYGROUP_TABLE9	This page is never used by Payroll Interface. Payroll Interface cannot process dynamic time and labor data.

Understanding Pay Groups

Pay groups are set up using the Pay Group Table component. The **PI Configuration ID** field on the Pay Group Table - Definition page is important for Payroll Interface. The **PI Configuration ID** links your PeopleSoft pay groups to the third-party payroll system.

Warning

If the **PI Configuration ID** is not set up correctly, the Payroll Interface processes will not function properly.

See [Setting Up the Configuration Table](#).

Additional information about pay groups is discussed in *PeopleSoft HCM Application Fundamentals*:

See Application Fundamentals: Setting Up Pay Groups.

Pay Group Table - Definition Page

Use the Pay Group Table - Definition page (PAYGROUP_TABLE1) to set up a pay group and its basic characteristics.

Navigation:

Set Up HCM, and then **Product Related**, and then **Payroll Interface**, and then **Payroll**, and then **Pay Group Table**, and then **Definition**

This example illustrates the fields and controls on the Pay Group Table - Definition page.

Field or Control	Description
PI Configuration ID (Payroll Interface Configuration ID)	Select to enter the Payroll Interface configuration ID. Note: If the PI configuration ID is not set up correctly, the Payroll Interface processes will not function properly.

Process Control Page

Use the Process Control page (PAYGROUP_TABLE2) to set up process controls and establish default employee types.

Navigation:

Set Up HCM, and then **Product Related**, and then **Payroll Interface**, and then **Payroll**, and then **Pay Group Table**, and then **Process Control**

This example illustrates the fields and controls on the Process Control page.

Definition | **Process Control** | Calc Parameters

Company GBI Global Business Institute
Pay Group KU4 US Monthly

Pay Group Information Find First 1 of 1 Last

Effective Date 12/26/2004 Status Active

Continue With Errors Processing Control

Continue With Errors Industry Core

Error Pay End Date Option None Chosen Industry Sector Core

Employee Type(s) for Pay Group Find View All First 1 of 3 Last

'Employee Type Excep Hrly

Print Paysheets

Confirmation Required for Job Earnings on Paysheet

Confirmation Required for Partial Pay Period on Paysheet

Pages 1 - 3 Pages 4 - 6 Pages 7 - 9

Calc Parameters Page

Use the Calc Parameters (calculate parameters) page (PAYGROUP_TABLE3) to set up other processing parameters for pay groups.

Navigation:

Set Up HCM, and then **Product Related**, and then **Payroll Interface**, and then **Payroll**, and then **Pay Group Table**, and then **Calc Parameters**

This example illustrates the fields and controls on the Calc Parameters page.

Definition | Process Control | **Calc Parameters**

Company GBI Global Business Institute
Pay Group KU4 US Monthly

Pay Group Information Find First 1 of 1 Last

Effective Date 12/26/2004 Status Active

Earnings Program ID KU1 US Earnings Program

Holiday Schedule KU01 US Holiday Schedule

Earnings

'Regular Hours REG 'Regular Earnings REG

'Overtime Hours OTP 'Holiday HOL

Default Benefit Program KU1

Retro Pay Program ID KU1

Retro Pay Trigger Program ID KU1

Final Check Program ID KU1

FLSA Required FLSA Period Definition

Pages 1 - 3 Pages 4 - 6 Pages 7 - 9

Bank/Tip Info Page

Use the Bank/Tip Info (Bank/Tip Information) page (PAYGROUP_TABLE8) to set up the bank from which employees are to be paid.

Navigation:

Set Up HCM, and then **Product Related**, and then **Payroll Interface**, and then **Payroll**, and then **Pay Group Table**, and then **Pages 7–9**, and then **Bank/Tip Info**

This example illustrates the fields and controls on the Bank/Tip Info page.

Field or Control	Description
Source Bank ID	Select the bank from which employees in this pay group are to be paid. Note: This field is not used by Payroll Interface. However, to save the pay group, you must enter a value.

Setting Up Balance IDs

To set up balance IDs, use the Balance ID Table (BALANCE_ID_TABLE) component.

See Application Fundamentals: Creating Balance IDs.

Setting Up Pay Run IDs

To set up pay run IDs, use the Pay Run Table (PAY_RUN_TABLE) component.

See Application Fundamentals: Creating Pay Run IDs.

Setting Up Pay Calendars

To set up pay calendars, use the Pay Calendar Table (PAY_CALENDAR_TABLE) component.

See Application Fundamentals: Creating Pay Calendars and FLSA Calendars.

8

Cloning a Payroll Interface Definition

Understanding the Cloning Process

Rather than setting up an entirely new interface definition, it may be easier to begin an implementation by cloning (copying) an existing interface definition, either a definition that you set up previously or one of the sample data definitions that is delivered with Payroll Interface.

PI Cloning Utility

The Payroll Interface control tables, sometimes referred to as the setup tables, are a set of 10 components that you use to set up an interface definition.

To create a copy of an interface definition, you use the PI cloning Utility to clone five of these components: PS Tables (PS_TABLES), Field Definition Table (INTRFC_FIELD), Group Table (INTRFC_GROUP), Instance Table (INTRFC_INSTANCE), and Definition Table (INTRFC_DEFINITION).

It is *not* necessary to clone these five components: System Table (SYSTEM_TABLE), Employee Table (INTRFC_EMPLOYEE), Process Table (INTRFC_PROCESS), File Handle Table (INTRFC_FILEHANDLE), and Configuration Table (INTRFC_CONFIG).

The PI Cloning Utility has two sub-utilities, the System ID Cloning Utility and the Interface Definition Cloning Utility. This table lists which components and underlying tables each sub-utility clones:

PI Cloning Utility	Component	Underlying Tables
Use the PI Cloning Utility, System ID Cloning Utility option to clone these components and the underlying tables, which include the System ID field as a key field.	PS Tables	<ul style="list-style-type: none">PI_PS_RECORDPI_PSREC_FLDPI_PS_REC_LANG
Field Definition Table	<ul style="list-style-type: none">PI_FIELD_TBLPI_FIELD_LANGPI_FIELD_XLAT	
Group Table	<ul style="list-style-type: none">PI_GROUP_TBLPI_GROUP_LANG	
Instance Table	<ul style="list-style-type: none">PI_INSTANCE_TBLPI_INSTANC_LANG	
Use the PI Cloning Utility, Interface Definition Cloning Utility option to clone this component and the underlying tables, which include the File ID as a key field.	Definition Table	<ul style="list-style-type: none">PI_DEFN_FILEPI_DEFN_F_LANGPI_DEFN_RECORDPI_DEFN_R_LANGPI_DEFN_FIELD

Cloning Procedure

Use the P.I. Cloning Utility Application Engine process (PI_CLONE) to clone an existing interface definition. The steps that you must perform before and after running the utility are outlined here.

To clone an interface definition:

1. Set up a system ID for the new interface definition using the System Table component.

2. Set up the file handles using the File Handle Table component.

For each file ID you will clone in step 3, create a file handle.

3. Clone the existing interface definition using the P.I. Cloning Utility process.

4. Update the file definitions using the Definition Table component.

For each file ID that you cloned in step 3, enter the system ID that you created in step 1.

5. Set up a configuration ID using the Configuration Table component.

Enter the system ID that you created in step 1, the file handles that you created in step 2, and the file IDs that the cloning process created in step 3.

See *PeopleTools: Process Scheduler*.

After you have performed these steps, you can manually configure the interface definition following the requirements of the third-party payroll system.

See:

- [Understanding the Control Tables](#)
- [Working with Interface Definitions](#)

Things to Consider

Verify the system ID after you have cloned the components. You may need to manually change the **System ID** field in the Definition Table component - Interface Definition File page (this is step 4 in the cloning procedure).

Verify the process IDs after you have cloned the components. Some processes may be specific to certain file types. For example, if you are cloning from a logical (LOG) file type to a comma-separated value (CSV) file type, then you don't want to retain Process ID = 00001 in the Deduction record definition.

Long description fields in the PS Tables component and in the Definition Table component - Interface Definition Record page become blank on the cloned records.

The PI_EMPLID_TBL table maps the PeopleSoft EMPLID to the third-party payroll system employee ID. When the Export process is run, every employee is assigned a row in this table. If the PI_EMPLID_TBL table contains data, you must delete it before running the Export process with the *new* (cloned) interface definition. If you do not delete the data, you will get a "duplicate rows" error message when you run the Export process.

Note

The PI_EMPLID_TBL table contains five fields: EMPLID, EMPL_RCD, EFFEDT, PI_SYSTEM_ID, and PI_EMPLID. To delete the data from this table, use this SQL statement: DELETE FROM PI_EMPLID_TBL.

See [Deduction Processing](#)

Cloning an Interface Definition

Pages Used to Clone an Interface Definition

Page Name	Definition Name	Usage
Clone Payroll Interface Page	PI_RUNCTL_SID_PNL	Select the cloning options and run the P.I. Cloning Utility Application Engine process (PI_CLONE) to copy an interface definition.

Clone Payroll Interface Page

Use the Clone Payroll Interface page (PI_RUNCTL_SID_PNL) to select the cloning options and run the P.I. Cloning Utility Application Engine process (PI_CLONE) to copy an interface definition.

Navigation:

Set Up HCM, and then **Product Related**, and then **Payroll Interface**, and then **Interface Controls**, and then **Clone Payroll Interface**, and then **Clone Payroll Interface**

This example illustrates the fields and controls on the Clone Payroll Interface page.

Clone Payroll Interface

Run Control ID PS Report Manager Process Monitor Run

Clone System ID

From Sys ID To Sys ID

PS Tables

Field Table

Group Table

Instance Table

Clone Interface Definition

From File ID To File ID

Clone System ID

Use the System ID Cloning Utility to copy the PS Tables, Field Table, Group Table, and Instance Table components and system IDs.

Field or Control	Description
Clone from Sys ID (clone from system ID)	Select the system ID of the interface definition that you want to copy (the existing interface definition).
Clone to Sys ID (clone to system ID)	Select the system ID of the interface definition that you want to create (the new interface definition). Note: You must set up the system ID using the System Table component before you can enter it here. See Setting Up the System Table .
PS Tables, Field Table, Group Table, and Instance Table	Select the components that you want to copy.

Clone Interface Definition

Use the Interface Definition Cloning Utility to copy the Definition Table component and file IDs.

Field or Control	Description
Clone from File ID	Select the file ID of the export or import file that you want to copy.
Clone to File ID	Select the file ID of the export or import file that you want to create.

Note

If you are copying more than one file ID (for example, the CSV sample data set includes four export files), set up and run the Interface Definition Cloning Utility separately for each file ID.

9

Setting Up a Payroll Interface Definition (Part 1)

Understanding the Control Tables

The Payroll Interface control tables, sometimes referred to as the setup tables, are a set of 10 components that you use to set up the export and import interface definitions. As shown in the following table, the components can be organized into four general usage groups. Although some dependencies exist, all 10 components work together and, for the most part, can be set up in any order.

Usage	Component
Use these components to identify the third-party payroll system and the employees who will be processed each pay period.	<ul style="list-style-type: none">• System Table (SYSTEM_TABLE) component• Employee Table (INTRFC_EMPLOYEE) component
Use these components to identify the PeopleSoft HCM tables and fields that store the payroll-related data, and to define the file and data formatting.	<ul style="list-style-type: none">• PS Tables (PS_TABLES) component• Field Definition Table (INTRFC_FIELD) component• Definition Table (INTRFC_DEFINITION) component
Use these components to set up additional processing for the payroll-related data. The processing can be simple (grouping fields) or more complex (invoking special COBOL routines).	<ul style="list-style-type: none">• Group Table (INTRFC_GROUP) component• Instance Table (INTRFC_INSTANCE) component• Process Table (INTRFC_PROCESS) component
Use these components to identify the export or import files and to connect the PeopleSoft HCM pay groups to the third-party payroll system for processing.	<ul style="list-style-type: none">• File Handle Table (INTRFC_FILEHANDLE) component• Configuration Table (INTRFC_CONFIG) component

Note

Beginning an implementation is often easier if you clone (copy) an existing interface definition. After you have created the clone, you can use the control tables to further configure the export or import interface definition.

Related Topics

- [Cloning an Interface Definition](#)

Common Elements Used in Working with Control Tables

Field or Control	Description
Null Blank Character Flds (null blank character fields), and Null Zero Numeric Flds (null zero numeric fields)	Select to indicate whether blank and zero PeopleSoft character fields should be written to the export file as null data. <i>Null</i> implies no data value for the field. You can override this option at the field level.
Convert Case	Select if the system requires uppercase. Note: You can override this setting for specific files.

Setting Up the System Table

To set up the System Table, use the System Table (SYSTEM_TABLE) component.

Pages Used to Set Up the System Table

Page Name	Definition Name	Usage
Interface System Table 1 Page	PI_SYSTEM_PNL	Set up system IDs.
Interface System Table 2 Page	PI_SYSTEM1_PNL	Set up payroll statuses.

Understanding the System Table

Use the System Table to set up a system ID that identifies the third-party payroll system.

Payroll Interface delivers several system IDs, including CSV, PHY, LOG, and NFC. These system IDs correspond to these delivered data formats: comma-separated-values, physical, logical, and National Finance Center. You can use the delivered system IDs or create your own.

You can use multiple system IDs to set up interface definitions for multiple third-party payroll providers. The system IDs separate the information required for each third-party implementation.

Related Topics

- [Sample Data Definitions](#)
PeopleSoft delivers sample data definitions for use with Payroll Interface. You can often more easily begin an implementation by cloning (copying) one of the sample data definitions.

Interface System Table 1 Page

Use the Interface System Table 1 page (PI_SYSTEM_PNL) to set up system IDs.

Navigation:

Set Up HCM, and then **Product Related**, and then **Payroll Interface**, and then **Interface Controls**, and then **System Table**, and then **Interface System Table 1**

This example illustrates the fields and controls on the Interface System Table 1 page.

Field or Control	Description
System ID	Select to enter a system ID that identifies the third-party payroll system. You can use one of the system IDs delivered with Payroll Interface (<i>CSV, LOG, NFC, PHY, and so on</i>) or you can define your own.
System Code	Select the appropriate system code. <ul style="list-style-type: none"> <i>ADP Interface</i>: ADP third-party payroll system. <i>Other</i>: Third-party payroll system other than ADP.
Version	For documentation only. Payroll Interface does not use this value.
Export	Select to indicate how data changes are exported. <ul style="list-style-type: none"> <i>Field Change Only</i>: Export only fields with changed data. <i>Record With Field Changes</i>: Export entire records, but only those with fields that have changed. <p>Note: The physical file format (PHY) does not export field changes only. The entire row is exported if a defined field changes.</p>

Field or Control	Description
Convert	<p>Select to indicate how employees are identified by the third-party payroll system.</p> <ul style="list-style-type: none"> <p><i>Using Interface Employee Table:</i> Converts the PeopleSoft EMPLID to the third-party payroll system employee ID (PI EmplID). Note: If you select this option, you <i>must</i> map the PeopleSoft EMPLID to the third-party payroll system employee ID (populate the PI_EMPLID_TBL table) for <i>each</i> employee before you run the Export process. If you do not do this, the system will issue an error message. Perform the mapping by either (1) manually entering the third-party payroll system employee ID in the Employee Table - Interface Employee Table page, PI Emplid field or (2) using PeopleCode to automate the process, when possible. You must update the mapping when employee changes occur, for example, new hires or terminations.</p> <p><i>Using PeopleSoft Employee ID:</i> Automatically inserts the PeopleSoft EmplID in the Employee Table - Interface Employee Table page, PI Emplid field (and populates PI_EMPLID_TBL) when you run the Export process.</p> <p><i>Using National ID:</i> Automatically inserts an applicable national identification code (for example, the employee's Social Security Number or Social Insurance Number) in the Employee Table component - Interface Employee Table page, PI Emplid field (and populates the PI_EMPLID_TBL table) when you run the Export process.</p>
Employee Field ID	<p>Select to indicate which Payroll Interface field contains the employee ID. The value of the employee field ID is defined on the Field Definition Table component - Interface Field2 page. Because of the three convert options, the field that you select as the employee field ID does not need any PS Record/PS fields mapped to it on the Interface Field2 page.</p>

Field or Control	Description
Effect Date Transaction Ind (effective date transaction indicator)	<p>Select <i>Current</i> to export only data that's current at the end of the pay period; select <i>All</i> to export both current and retroactive data.</p> <p>Note: Be sure to verify that your payroll vendor's import utility accepts multiple effective-dated transactions.</p> <p>The effective date indicator performs two main functions:</p> <ul style="list-style-type: none"> • Selecting employees for processing: If you choose <i>All</i>, all employees who have <i>ever</i> been in the pay group being processed are eligible for processing. If you choose <i>Current</i>, only those employees who were in the pay group <i>during</i> the pay period are eligible for processing. • Retrieving employee data: If you select <i>All</i>, the meaning of the value <i>All Effdts</i> (all effective dates) in the Where Clause Type field on the PS Tables page literally means <i>all</i> effective dates. If you choose <i>Current</i>, then <i>All Effdts</i> on the PS Tables page refers to all effective dates that are effective during the pay period.
Process Filter	<p>Select to indicate whether the system should process records with a company value that is different from the process company.</p> <ul style="list-style-type: none"> • <i>None</i>: All rows that are created by Payroll Interface for each company and pay group combination are inserted into the PI_PARTIC_EXPT table and are available for export. The last history rows that are created for the current system ID are retrieved for comparison. • <i>Company</i>: If you define a key field of <i>Company</i> on the Definition Table component - Interface Definition Fields page, this field is compared to the process company. The system exports only records with a matching company. For comparison, the system retrieves the last history rows that were created for the current system ID and company.
Character Set	<p>Select to enter the appropriate character set for the language that is used in the export or import file.</p> <p>Note: The Import process recognizes only the ASCII character set.</p> <p>See Working with Character Sets.</p>

Field or Control	Description
File Type	<p>Select a file type:</p> <ul style="list-style-type: none"> • <i>CSV</i> (comma-separated value): Data is delimited, or separated, by commas. • <i>Logical</i>: Data is defined using an identifier followed by its value, not fixed format. For example, the field identifier of 1X2 might always immediately precede a value of 1 or 2 to indicate tax status. The field identifier is defined by your third-party payroll system and must exactly match the field identifier that is defined in Payroll Interface. If you use a logical file, select <i>External Field ID Indicator</i> and enter the field length. • <i>Other Delm</i> (other delimited): Data is delimited by the character that you specify in the Data Delimiter field. <p>Note: A delimited data file can contain only one Payroll Interface record definition of the data type. You can have two record definitions only for a Stop Transaction record. Common examples are deductions, savings plans, additional pay, and direct deposit.</p> <p>Numeric values cannot contain the thousands edit characters. For example: 1,100,100 appears in both the import and export files as 1100100. The system <i>does</i> support a display character for the decimal place, for example, 100.50 or 100,50.</p> <ul style="list-style-type: none"> • <i>Physical</i>: Data is defined by its position in the file. For example, a value of 1 or 2 in the 30th character position in the file might represent tax status. In such files, blank characters are often inserted to maintain positional integrity when a data value is not available to take that position. • <i>Tab Delm</i> (tab delimited): Data is delimited by the Tab character.

Logical File Type and Delimiter File Types

Use the options in the Logical File Type group box and Delimiter File Types group box to further define the export file.

Field or Control	Description
Literal String Character	<p>If the decimal character is the same as the delimiter character, it must be enclosed in the literal string character. This applies to both export and import files. For example, if the decimal character is a comma, and the file type is CSV, all numeric values that contain decimals must be enclosed by the literal string character: "100,50" for example.</p> <p>In an export file, all character values must be enclosed by the literal string character. A sample record might be: 1235,"abcd","ef gh", "Last Name, First Name".</p> <p>When data values contain the literal string character, the single character is repeated within the data value when it is written to the export file. During the import process, the system examines the data value for two literal string characters together and changes them to just one. For example, a data value from the database is Suite 200, Unit "A" West. The data value is written to the export file as "Suite 200, Unit ""A"" West". The import process interprets the export data string and loads it into the database as: Suite 200, Unit "A" West.</p>
Remove Trailing Spaces	You can override this selection at the field level.
Include Header	<p>For delimited file types, select to indicate whether a header record is the first record. When this option is selected for export files, a header is written as the first record in the file. The header name is the external column name for each field on the record. When this option is selected for input files, the header record is compared to the record definition. If they do not match, the system stops processing for that file.</p>

Interface System Table 2 Page

Use the Interface System Table 2 page (PI_SYSTEM1_PNL) to set up payroll statuses.

Navigation:

Set Up HCM, and then **Product Related**, and then **Payroll Interface**, and then **Interface Controls**, and then **System Table**, and then **Interface System Table 2**

This example illustrates the fields and controls on the Interface System Table 2 page.

Interface System Table 1

Interface System Table 2

System ID PHY

Active Employees for Export
Find | View All
First ◀ 1 of 1 ▶ Last

Effective Date 01/01/1980 + -

Description Physical File Format

Payroll Statuses
Personalize | Find | View All | |
First ◀ 1 of 1 ▶ Last

Payroll Status

Active ▼

+ -

Payroll Statuses

Field or Control	Description
Payroll Status	<p>Select the pay statuses of the employees to process. This setting directly corresponds to the Selecting Active Employees check box on the Payroll Interface Run Control page.</p> <p>Note: Employee payroll status is assigned in Job data.</p> <p>Note: Payroll Interface processes only the current row if more than one effective sequence exists for a particular date.</p>

Setting Up the Employee Table

To set up the Employee Table, use the Employee Table (INTRFC_EMPLOYEE) component.

Page Used to Set Up the Employee Table

Page Name	Definition Name	Usage
Interface Employee Table Page	PI_EMPLID_PNL	Set up employee IDs when the third-party payroll system employee IDs are independent of the PeopleSoft EMPLID.

Understanding the Employee Table

Use the Employee Table component to determine how your employees are identified in the third-party payroll system.

You can export data from any table or view in PeopleSoft HCM, as long as the record includes the PeopleSoft EmplID. To identify employees in a third-party payroll system, you can use the PeopleSoft and map the PeopleSoft EmplID to a third-party employee ID (PI EmplID) or some other unique identifier such as a Social Security Number.

Related Topics

- [Deduction Processing and Multiple Jobs](#)
To calculate deductions for an employee with multiple jobs, the following criteria is used:
- [Export Processing and Multiple Jobs](#)
To export data for an employee with multiple jobs, the following criteria is used:

Interface Employee Table Page

Use the Interface Employee Table page (PI_EMPLID_PNL) to set up employee IDs when the third-party payroll system employee IDs are independent of the PeopleSoft EMPLID.

Navigation:

Set Up HCM, and then **Product Related**, and then **Payroll Interface**, and then **Interface Controls**, and then **Employee Table**, and then **Interface Employee Table**

This example illustrates the fields and controls on the Interface Employee Table page.

Interface Employee Table

The screenshot shows the 'Interface Employee Table' page for employee William Fraas. At the top, it displays 'William Fraas', 'EMP', 'ID KUI011', and 'Empl Record 0'. Below this is a search bar with 'Payroll Interface Employee ID' and navigation options 'Find | View All | First 1 of 1 | Last'. The main form contains three fields: 'Effective Date' with the value '12/04/2012', '*System ID' with the value 'PHY' and a dropdown menu showing 'Physical File Format', and 'PI Emplid' with the value 'KUI011'.

Field or Control	Description
System ID	Select the System ID for the third-party payroll system.
PI Emplid (Payroll Interface employee ID)	Enter the ID that uniquely identifies your employees to the third-party payroll system. Note: The value of the PI Emplid field can be the third-party payroll system employee ID, the PeopleSoft EMPLID, or a national identifier such as the employee's Social Security Number. The option that you select for the System Table - Interface System Table 1 page, Convert field determines how the PI Emplid field is populated. See Setting Up the System Table .

Setting Up the PS Tables

To set up the PS Tables, use the PS Tables (PS_TABLES) component.

Pages Used to Set Up the PS Tables

Page Name	Definition Name	Usage
PS Tables Page	PI_PSREC_PNL	Select PeopleSoft tables and fields that contain employee payroll-related data. Data is extracted from these tables and fields during the Export process.
PeopleSoft Field Inquiry	PI_PSFLD_INQ	View attributes for a selected field.

Understanding the PS Tables

Use the PS Tables component to identify the PeopleSoft HCM tables and fields that contain the data that will be exported to the third-party payroll system or used during the Export process.

You can export data from any table or view in PeopleSoft HCM, as long as the record includes the PeopleSoft EMPLID field. The system uses the parameters on the PS Tables page to construct the SQL select statements.

Note

Any field that is identified in the PS Tables component can be added to the Field Definition component. Any field that is defined in the Field Definition Table component can be added to the Definition Table component.

PS Tables Page

Use the PS Tables (PeopleSoft Tables) page (PI_PSREC_PNL) to select PeopleSoft tables and fields that contain employee payroll-related data.

Navigation:

Set Up HCM, and then **Product Related**, and then **Payroll Interface**, and then **Interface Controls**, and then **PS Tables**, and then **PS Tables**

This example illustrates the fields and controls on the PS Tables page.

PS Tables

Details
Find | View All First 1 of 1 Last

System ID PHY Physical File Format + -

Record (Table) Name ADDL_PAY_DATA

Description PeopleSoft Addition Pay Data

Process Type Export

Where Clause Type ID, All EffDts , Active EffSeq

Paygroup Company in Where Data Required
 Paygroup Country in Where Job Data
 Ded Calc Data

Field Details
Personalize | Find | View All First 1-3 of 36 Last

Field Attribute Button	Field Name	Order by	Collate Order	Key Field	Effective Date	Effective Sequence	
Field Attribute Button	ACCT_CD			<input type="checkbox"/>	<input type="checkbox"/>	<input type="checkbox"/>	+ -
Field Attribute Button	ADDLPAY_REASON			<input type="checkbox"/>	<input type="checkbox"/>	<input type="checkbox"/>	+ -
Field Attribute Button	ADDL_PAY_FREQUENCY			<input type="checkbox"/>	<input type="checkbox"/>	<input type="checkbox"/>	+ -

Data is extracted from these tables and fields during the Export process.

Field or Control	Description
System ID	The system ID for the third-party payroll system.
Process Type	Select to indicate which Payroll Interface process to perform with the table or view.

Field or Control	Description
Where Clause Type	<p>Select to indicate which type of SQL Where clause to construct when retrieving the data from the database:</p> <ul style="list-style-type: none"> • <i>Empl ID</i>: Employee ID only. • <i>ID and Active Effdt</i>: Employee ID and the active effective date as of the pay end date. • <i>ID, Active Effdt, Active EffSeq</i>: Employee ID, the active effective date, and the latest effective sequence as of the pay end date. • <i>ID, All Effdts, Active EffSeq</i>: Employee ID, all effective-dated rows that fall between the pay-begin date, the pay-end date (non-retroactive processing), and the latest effective sequence for each effective date. • <i>ID, All Effdts</i>: Employee ID and all the effective-dated rows that fall between the pay-begin date and the pay-end date (non-retroactive processing). • <i>ID, Effdt=Pay End Dt</i>: Employee ID and effective date equal the pay end date. <p>To become more familiar with the differences between these Where clause types, try them out using PeopleSoft Query.</p> <p>See <i>PeopleTools: PeopleSoft Query</i></p> <p>Note: If you select <i>Import</i> in the Process Type field, this field is not available.</p>
Paygroup Company in Where	<p>Select to indicate whether the Where clause for retrieving data from this PeopleSoft table should include a test on the Company field. When this check box is selected, the system compares the Company field in the record against the Company field in the employee's job data.</p> <p>Select this check box when an employee could have more than one entry in the PeopleSoft table that could be uniquely identified by the Company field. An example of this is the employee's tax data.</p>
Paygroup Country in Where	<p>Select to indicate whether the Where clause for retrieving data for this PeopleSoft table should include a test on the Country field. When this check box is selected, the system compares the Country field in the record against the Country field from the company/pay group to which the employee belongs. The company/pay group is based on the employee's job data.</p> <p>Select this check box when an employee could have more than one entry in the PeopleSoft table that could be uniquely identified by the Country field. An example of this is the employee's national ID data.</p>

Field or Control	Description
Ded Calc Data (deduction calculation data)	Select to indicate that one or more fields listed for this table or view comes from the PI_DED_CALC table. When you run the Export process with a run control defined to exclude DedCalc, the system excludes any record for which this check box is selected. When the PS record table name is PI_DED_CALC, this check box is always selected.
Data Required	Select to indicate that a row of data must be returned from the database for this table, but not that every field that is defined for this record must contain data. If a row of data is not returned for this record, the system issues an error message, and no data for the employee is written to the export file.
Job Data	Select if the record contains COMPANY, PAYGROUP, or ACTION. If the PS record table name is JOB, this check box is always selected.

Field Details

Use the Field Details group box to define field attributes.

Note

You should enter Order by (sequence) values for all key fields. The EFFDT and EFFSEQ fields *must* be in descending order (Collate Order Desc). All other fields should be in ascending order (Collate Order Asc).

Field or Control	Description
Order by	Select to indicate the sequence in which the field should be processed. A number from zero (blank) to 99 represents the sequence of the field in the ORDER BY clause of the SQL select statement.

Field or Control	Description
Collate Order	<p>This field is applicable only when the value for the Order by field is greater than zero. Select to indicate the sequence order of the field in the ORDER BY clause of the SQL select statement. (If the value of the Order by field is zero or not specified, the collate order is none by default.)</p> <p><i>Asc</i>: Ascending order. Sequences data from lowest to highest. This is the default value for all fields.</p> <p><i>Desc</i>: Descending order. Sequences data from highest to lowest.</p> <p>Note: The EFFDT and EFFSEQ fields <i>must</i> be in descending order.</p> <p>See Working with Key Fields.</p>
Key Field	<p>This check box is automatically selected if the field is defined in PeopleSoft Application Designer as a key for a PS record.</p> <p>You must manually select this check box for views.</p>
Effective Date	<p>Only one field can be the Effective Date field. The system uses the Effective Date field name in constructing the Where clause of the SQL select statement when the SELECT_WHERE_TYPE includes the effective date.</p> <p>The Effective Date field for the DED_CALC Table is Pay End Date.</p>
Effective Sequence	<p>Only one field can be marked as the <i>Effective Date</i> sequence number. The system uses the effective date sequence number in constructing the Where clause of the SQL select statement when the SELECT_WHERE_TYPE includes the <i>Effective Date</i> sequence field.</p> <p>This field is used with the JOB record and any other records with both an effective date and effective sequence.</p>
Field Attribute	<p>Select to view the PeopleSoft Field Inquiry secondary page.</p>

Setting Up the Field Definition Table

To set up the Field Definition Table, use the Field Definition Table (INTRFC_FIELD) component.

Pages Used to Set Up the Field Definition Table

Page Name	Definition Name	Usage
Interface Field1 Page	PI_FIELD1_PNL	Set up third-party payroll system fields.

Page Name	Definition Name	Usage
Interface Field2 Page	PI_FIELD2_PNL	Set up corresponding PeopleSoft fields.

Understanding the Field Definition Table

Use the Field Definition Table component to define the data type and format of the fields that appear in the export file. Any field that is identified in the PS Tables component can be added to the Field Definition component.

Note

The Field Definition Table component and the Definition Table component contain effective-dated entries. You must keep these components synchronized. Be sure that future-dated rows in the Field Definition Table component are not referenced in the Definition Table component before their effective dates. Also, if you mark a field inactive in the Field Definition Table component, be sure that the field is no longer included in the Definition Table component.

See [Working with Key Fields](#).

Interface Field1 Page

Use the Interface Field1 page (PI_FIELD1_PNL) to set up third-party payroll system fields.

Navigation:

Set Up HCM, and then **Product Related**, and then **Payroll Interface**, and then **Interface Controls**, and then **Field Definition Table**, and then **Interface Field1**

This example illustrates the fields and controls on the Interface Field1 page.

The screenshot shows the 'Interface Field1' page for Field ID D001. The page is divided into two main sections: 'Field Definition' and 'Field Format'.

Field Definition Section:

- 'Effective Date': 01/01/1980
- Description: Deduction Code
- External Field ID: D001
- 'Type': Character
- External Column Name: Deduction Code
- 'Status': Active
- Short Desc: Ded Cd
- Process Type: Export
- Text: (empty)
- Default Value: ZZ

Field Format Section:

- 'Field Length (in bytes)': 8
- Decimal Length: (empty)
- Display Decimal:
- Integer Length: (empty)
- Round Decimal: (empty)
- Blank If Zero:
- Sign Position: (empty)
- Negative: -
- Use Positive Sign:
- Justification: Left
- Pad Character: (empty)
- Date Format: (empty)
- Remove Trailing Spaces:
- Null Blank Character Flds:
- Null Zero Numeric Flds:

Field Definition

Field or Control	Description
Process Type	<p>Select the Payroll Interface process.</p> <p>Note: <i>Exp/Imp</i> (export/import) can be used as the process type only if the characteristics of the field are the same for both import and export. Otherwise, you need to set up records for each process type. The Employee ID field is the only field that is mapped as both an export and import type; you do not need to define a PS record or field name for it.</p>
External Field ID	<p>If the System Table - Interface System Table 1 page, External Field ID Indicator option is selected, the external field ID becomes by default the value that you enter here. The external field ID can be up to 10 characters.</p>
Type	<p>Select from the following options:</p> <ul style="list-style-type: none"> • <i>Character</i> Use the Justification field to specify whether characters are left or right justified. Note: When you are mapping from a large field to a smaller field, the results are truncated. For example, if you map '0123456789' from a 10-character field to a 7-character field, the result is '0123456'. • <i>Date</i> Use the Date Format field to specify the third-party payroll system's date format. • <i>Number</i> Use the Display Decimal and Decimal Char (decimal character) fields to specify a decimal separator. • <i>Signed</i> Use the Sign Position field to select the placement of the sign for signed numerical fields. • <i>Value</i> Select to specify a predefined data item for the Text field. For example, with the Pay Run ID field, enter <i>Pay Run ID</i> as the text. (Including <i>Pay Run ID</i> in the header record may help ensure that the correct file is processed.) If using the company filtering feature, use the <i>Processing Company</i> or <i>Processing Pay Group</i> values for the <i>Text</i> field. See Working with Company Filtering.
Text	<p>Select to enter a translate value.</p> <p>Note: This field is active only if you have selected <i>Value</i> in the Type field.</p> <p>See Working with Text Translate Values.</p>

Field or Control	Description
External Column Name	Select to enter a name of up to 50 characters if the Interface field is used in a delimited data file structure with a header. The system uses this name to construct the header record.
Default Value	If you use <i>constant</i> in the <i>Text</i> field, the value that you enter here is used. You can also use a default value for the character type. For example, if the field is part of a header record, you can specify some fixed text as the default value.
Field Format	
Use the options in the Field Format group box to define the file's field formats.	
Field or Control	Description
Field Length (in bytes)	For physical file formats, the length determines where the field will be positioned. When you are setting up the Interface Definition Fields page, you can view the exact character position of the field.
Integer Length	The system calculates the integer length to verify that you have set up a numeric field as intended. For a signed field type, the system subtracts one position from the integer length to allow for the sign. Use <i>Sign Position</i> to specify where the sign goes.
Blank if Zero	This field is active only for number or signed field types. Select if the payroll system uses blanks in place of zeros.

Interface Field2 Page

Use the Interface Field2 page (PI_FIELD2_PNL) to set up corresponding PeopleSoft fields.

Navigation:

Set Up HCM, and then **Product Related**, and then **Payroll Interface**, and then **Interface Controls**, and then **Field Definition Table**, and then **Interface Field2**

This example illustrates the fields and controls on the Interface Field2 page.

Interface Field1
Interface Field2

System ID CSV CSV Sample Layout
Field ID D001

Field Definition
Find | View All
First 1 of 1 Last

Effective Date 01/01/1980

PS Record Name

PS Field1 Name

PS Field3 Name

Instance ID

Description Deduction Code

Process ID Tilde Chr

PS Field2 Name

PI Translate Indicator

Translate Values
Personalize | Find | View All
First 1-2 of 4 Last

PS Value 1	PS Value 2	PS Value 3	PI Value
<input type="text" value="KUDEN9"/>	<input type="text" value="B"/>	<input type="text"/>	<input type="text" value="D1"/>
<input type="text" value="KUHMOK"/>	<input type="text" value="B"/>	<input type="text"/>	<input type="text" value="M1"/>

Field Definition

Field or Control	Description
PS Record Name and PS Field1 Name, PS Field2 Name, PS Field3 Name	Select the PeopleSoft record and field names that correspond to the third-party payroll system field. If the third-party payroll system field value is derived from multiple PeopleSoft fields, enter the additional field names as well.
Process ID	Select when a COBOL process is required to correctly translate or format a PeopleSoft value to a third-party payroll system value. Note: Process IDs are defined on the Interface Process Table.
PI Translate Indicator (payroll interface translate indicator)	Select to specify how translate values are handled: <ul style="list-style-type: none"> • <i>No Translate Values</i> • <i>Translate All</i> • <i>Translate or Use Default Value:</i> Translate if a translate value is found; if not, use the default value that is defined on the Interface Field1 page. • <i>Translate or Use PS Value:</i> Translate if a translate value is found; if not, use the PeopleSoft value.
Instance ID	Select to control which values of a field should be mapped to the external payroll system.

Translate Values

Select to translate PeopleSoft field value **PS Value 1** (and, if needed, **PS Value 2** and **PS Value 3**) to the **third-party payroll system value, PI Value**. For example, if **DEDCD** (deduction code) is **KUDEN9** and **DED_CLASS** (deduction class) is **B** (before tax), then the translated value is **D1**.

Translate values are available for all export fields and for the **Currency Code** field for import.

Related Topics

- [Creating COBOL Routines](#)

You can create your own COBOL routines for use with Payroll Interface. The system isolates your COBOL routines from the delivered Payroll Interface COBOL processes and calls them by retrieving the name specified on the Process Table component - Interface Process Table page, **User Exit Program** field.

Setting Up the Definition Table

To set up the Definition Table, use the Definition Table (INTRFC_DEFINITION) component.

Pages Used to Set Up the Definition Table

Page Name	Definition Name	Usage
Interface Definition File Page	PI_FILE1_PNL	Set up a file layout for the import or export file.
Interface Definition Record Page	PI_FILE2_PNL	Set up the records in a file.
Interface Definition Fields Page	PI_FILE3_PNL	Set up the fields in a record.

Understanding the Definition Table

Use the Definition Table component to define the physical structure of the export or import file, including the records in the file and the fields in the records. Any field defined in the Field Definition Table component can be added to the Definition Table component.

 **Note**

Each record in the file must include the field that is defined as the EMPLID on the System Table component.

 **Warning**

If you use PeopleSoft Application Designer to change any of the tables or fields set up using the PS Tables component, you must make sure that these changes are reflected in the PS Tables component as well. If you think that a change that you have made has not taken affect, delete the database cache file and log back into the system.

See PeopleTools: Application Designer Developer's Guide

Interface Definition File Page

Use the Interface Definition File page (PI_FILE1_PNL) to set up a file layout for the import or export file.

Navigation:

Set Up HCM, and then Product Related, and then Payroll Interface, and then Interface Controls, and then Definition Table, and then Interface Definition File

This example illustrates the fields and controls on the Interface Definition File page.

File ID Definition

Field or Control	Description
System ID	Select the system ID for the third-party payroll system.
Convert Case	Select this check box to have the system automatically select the Conv. Case check box for each <i>new</i> field that you enter on the Interface Definition Fields page of this component. If you need to update the value of the Conv. Case check box for <i>existing</i> fields, you must manually select or deselect that check box on the Interface Definition Fields page for each of those fields. Selecting or deselecting the check box on this page does not update existing values.
Include Header	Is on or off by default according to values that are set up on the System Table component for the selected system ID.
PI Record Length	Select to enter the record length for the file type. For comma-separated (CSV), tab-delimited, and other delimited file types, the value must be zero.
Max Fields Per Output Rec (maximum fields per output record)	Used for logical records. Select the value that is defined by the third-party payroll system.
External Field ID Indicator	Used for logical records. When this check box is selected, the data records contain the external field ID as defined on the Interface Field1 page for all of the fields that are defined in the interface definition record.

Interface Definition Record Page

Use the Interface Definition Record page (PI_FILE2_PNL) to set up the records in a file.

Navigation:

Set Up HCM, and then **Product Related**, and then **Payroll Interface**, and then **Interface Controls**, and then **Definition Table**, and then **Interface Definition Record**

This example illustrates the fields and controls on the Interface Definition Record page.

The screenshot shows the 'Interface Definition Record' page with the following fields and values:

- File ID:** PHY
- Physical File Layout:** Effective Date: 01/01/1980
- Record Definition:**
 - Rec Seq Nbr:** 9
 - Record ID:** HEAD
 - 'Record Type:** Header
 - Description:** Header for Personal Data
 - PS Record:** JOB
 - Base Rec:** (empty)
 - 'Occur Ind:** Single Rec to Single Defn Rec
 - InstanceID:** (empty)
 - Record Terminated Value:** ~
 - Process ID:** (empty)
 - Record Terminated Length:** 1
 - Description:** (empty text area)

Field or Control	Description
Rec Seq Nbr (record sequence number)	Select to indicate the sequence of each record within the file. Note: The system assigns sequence numbers as you add or delete records. If your external system requires a specific record sequence, make sure the sequence reflects that.
Record ID	Each record definition should have a unique ID. Record definitions are used for organizing data for the Export process and for defining the export file. So you are likely to have more record definitions on this table than are described by your payroll system documentation. If the third-party payroll system has its own record IDs, you might want to use those.

Field or Control	Description
Record Type	<p>Select from the following:</p> <ul style="list-style-type: none"> • <i>Header</i>: Written out first to identify the beginning of a file. Multiple headers are allowed. • <i>Trailer</i>: Written out last to identify the end of a file. • <i>Data</i>: Imported or exported data. A data record must have a primary PS record. • <i>Process</i>: Record definitions used by a COBOL process and associated with specific process events, such as stop deductions. Process records must also identify the Base Rec field (base record). • <i>Not Procd</i> (not processed): Used for import files only. This indicates a payroll system record within the import file that is not processed by Payroll Interface. <p>If you select any type other than <i>Process</i>, then the row builds a record type within the file.</p> <p>If you have multiple data-type records, the first data record should have the Primary PS Record set to Job.</p> <p>Note: (<i>for CSV files</i>) Each data-type record needs to be assigned to a separate, individual interface definition file. If you have multiple records (and interface definitions), assign each of them to the appropriate PI Configuration ID.</p>
PS Record	<p>Select to identify the PeopleSoft table that is selected from (for export) or inserted into (for import) as the primary PeopleSoft table for this interface record.</p> <p>Note: Each data record must contain the field that is defined as the employee field ID on the System Table component.</p>
Base Rec (base record)	<p>Available for process record types.</p> <p>The data value that is used in the Base Rec field is a record sequence number from another row on this table. The base record ties the indicated process to another sequence number row. For example, if the row that is labeled with sequence number 80 concerns deduction data and the row that is labeled 140 defines the process ID that is used to stop the deduction, then 80 is the base record for record sequence number 140.</p>

Field or Control	Description
Occur Ind (occurrence indicator)	<p>Select to identify the correspondence between rows in the PS record and the records in the export file.</p> <ul style="list-style-type: none"> <p><i>Multi Recs to Multi Defn Recs</i> (multiple records to multiple definition records)</p> <p>Data is pulled from a PeopleSoft record that may have multiple records (or rows) of information to multiple definition payroll system records (or rows) of information. The Occurrence Key field is required to distinguish each occurrence.</p> <p>Example: Ded Calc and Additional Pay may have more than one row of employee data that the system needs to read to determine whether data changed. You would pull all rows of data and write them to multiple rows on the payroll system data file.</p> <p>Example:</p> <p>(SSN, Ded Code, Ded Amount)</p> <p>"354567980","401K",200.00</p> <p>"354567980","HEALTH",150.00</p> <p>"354567980","UWAY",50.00</p> <p>"354567980","VISION",25.00</p> <p>or</p> <p>(SSN, Pay Code, Pay Amount)</p> <p>"354567980","CAR",200.00</p> <p>"354567980","DIEM",250.00</p> <p>"354567980","FLEX",60.00</p> <p><i>Multi Recs to Single Defn Rec</i> (multiple records to single definition record)</p> <p>Data is pulled from a PeopleSoft record that may have multiple records (or rows) of information to a single payroll system record (or row) of information.</p> <p>Example: Direct Deposit may have more than one row of employee data that the system needs to read in order to determine whether the data changed. You would want to pull all rows of data from PeopleSoft and write them to one row on the payroll system data file.</p> <p>Example:</p> <p>(SSN, Trans/ABA, Account #, Account Type, Amount)</p> <p>"354567980","123456789","85987-00","C",500.00,"123456789",85987-001","S",200.00,"123456789","85987-002","S",50.0</p> <p><i>Single Rec to Single Defn Rec</i> (single record to single definition record)</p> <p>Data is pulled from a single PeopleSoft record (or row) and put in a single payroll system record (or row) of information.</p> <p>Example:</p>

Field or Control	Description
	(Name, Address, City, Country) "Doe,Jane","854 Mill Rd","Anywhere","USA"
Instance ID	Defined on the Instance Table - Interface Instance Table page.
Process ID	Select when a special COBOL process is required to correctly translate or format PeopleSoft values for your payroll system. Payroll Interface delivers process IDs for several special events. These events set an indicator that can be used later by another special process indicator: See Reviewing Delivered COBOL Processes for Special Events .
Record Terminated Value and Record Terminated Length	Available for data entry only if the file type selected on the Interface Definition File page is <i>Physical</i> or <i>Logical</i> . Enter a value only if your external payroll system needs a specific value to identify the end of the record.

Interface Definition Fields Page

Use the Interface Definition Fields page (PI_FILE3_PNL) to set up the fields in a record.

Navigation:

Set Up HCM, and then **Product Related**, and then **Payroll Interface**, and then **Interface Controls**, and then **Definition Table**, and then **Interface Definition Fields**

This example illustrates the fields and controls on the Interface Definition Fields page.

The screenshot shows the 'Interface Definition Fields' page. It includes a navigation bar with 'Interface Definition File', 'Interface Definition Record', and 'Interface Definition Fields'. Below the navigation bar, there are sections for 'File ID' (PHY - Physical File Layout, Effective Date: 01/01/1980), 'Definition' (Rec Seq Nbr: 9, Record ID: HEAD, Header for Personal Data, PS Record: JOB), and 'Fields'. The 'Fields' section contains a table with the following data:

Field Sequence	Redefine	Field ID	Description	Start Position	Field Length	Field Name	Convert Case	Reverse Sign	Key Field	Group ID
10	<input type="checkbox"/>	COMPNY	Company	1	6		<input type="checkbox"/>	<input type="checkbox"/>	Record Lev	
20	<input type="checkbox"/>	RUNID	Run Id	7	6		<input type="checkbox"/>	<input type="checkbox"/>	Record Lev	

Fields

Use the options in the Fields group box to define, order, and group the individual fields in a record.

Field or Control	Description
Field Sequence (field sequence number) and Field ID	Select to enter a field and its position within the record (field IDs are defined on the Field Definition Table component). Note: When you set up a transaction and its corresponding stop transaction, the field sequences in both records must match.
Redefine (redefine)	If the field's position in a record is also used by a subsequent field for a different purpose, use this check box to select the secondary field for later use. The secondary field must immediately follow the first definition with this position in the record.
Start Position, Field Length, and Field1 Name	Calculated from the Interface Field Table. For physical files, the starting position and field length can be used to validate that the length of the fields has been set in the correct layout.
Convert Case	Used for ASCII files only. Select to override the case default for a field.
Reverse Sign	Select if the field is signed numeric type and the payroll system requires that the sign be reversed.
Key Field	Select from the following values: <ul style="list-style-type: none"> <i>None</i>: Indicates a data-only field. <i>Non Key</i>: Indicates a non-key field. <i>Record</i>: Defines a field as a primary record key. The system formats only one record per employee. Note: To make a field a record key, every key value in every row above the field must also be defined as a record key. The system delivers a COBOL error message if you order the key field in a manner such as <i>Non Key</i>, <i>Record</i>, and <i>Non Key</i>. <i>Occurrence</i>: Defines a field as an occurrence key. Occurrence key processing allows multiple records to be formatted. See Working with Key Fields. <i>Effdt</i>: Defines a field as an effective-date key. An effective-date key is special type of occurrence key. In addition to occurrence key functionality, further processing eliminates redundant information. See Working with Key Fields. <i>Company</i>: If a field is defined as <i>Company</i> and the value on the System Table, Interface System Table 1 page - Process Filter field is set to <i>Company</i>, the system activates a filtering mechanism. Only rows with a Company value matching the processing company (the company tied to the run ID) are formatted and passed to the interface. See Working with Company Filtering.

Field or Control	Description
Group ID	Select to indicate that the field belongs to a group of fields. All fields in the record with the same group ID are exported or imported together (if a data change occurs to one field in the group, all fields in the group are exported).

Setting Up the Group Table

To set up the Group Table, use the Group Table (INTRFC_GROUP) component.

Page Used to Set Up the Group Table

Page Name	Definition Name	Usage
Interface Group Table Page	PI_GROUP_PNL	Set up group IDs that identify multiple fields to be imported or exported together.

Understanding the Group Table

Use the Group Table component to define a group ID. Group IDs are used to group two or more fields for export or import:

- For export processing, a group ID is used to identify multiple fields that must be exported together when data changes in any field in the group.
- For import processing, a group ID identifies multiple fields that correspond to one row in the PI Check Table or the PI Balance Table. The PI Check Table and PI Balance Table are populated when you import data by way of Payroll Interface from your third-party payroll service.

Note

The import group ID can associate an additional field and value for the PeopleSoft import table. This allows a record position in the import file to be translated to a key value in the PeopleSoft import table.

Interface Group Table Page



Use the Interface Group Table page (PI_GROUP_PNL) to set up group IDs that identify multiple fields to be imported or exported together.

Navigation:

Set Up HCM, and then **Product Related**, and then **Payroll Interface**, and then **Interface Controls**, and then **Group Table**, and then **Interface Group Table**

This example illustrates the fields and controls on the Interface Group Table page.

Interface Group Table

System ID	PHY	Physical File Format
Group ID	DED	
Process Type	Export	
Description	Deduction Code and Amount	
Short Description	Deds	
PeopleSoft Record Name	EMPLOYEES	
PeopleSoft Field1 Name	EMPLID	
PS Key Value	EMPLID	

Field or Control	Description
Process Type	<p>Select to enter the Payroll Interface process, either export or import.</p> <p>For export processing, a group ID is used to identify multiple fields that must be exported together when data changes in any field in the group.</p> <p>For import processing, a group ID identifies multiple fields that correspond to one row in the PI Check Table or the PI Balance Table. The PI Check Table and PI Balance Table are populated when you import data by way of Payroll Interface from your third-party payroll service.</p> <p>Note: The import group ID can associate an additional field and value for the PeopleSoft import table. This allows a record position in the import file to be translated to a key value in the PeopleSoft import table.</p>
PeopleSoft Record Name and PeopleSoft Field1 Name	<p>Available for process type import. Select to define the PeopleSoft record and field where the import data is inserted. This allows translation of a record position in the import file to a key value in the PeopleSoft table.</p>

Setting Up the Instance Table

To set up the Instance Table, use the Instance Table (INTRFC_INSTANCE) component.

Page Used to Set Up the Instance Table

Page Name	Definition Name	Usage
Interface Instance Table Page	PI_INSTANCE_PNL	Set up instance IDs to filter PeopleSoft data that is mapped to Payroll Interface fields or records.

Understanding the Instance Table

Use the Instance Table component to define instance IDs that act as filters and process records (row instances) or fields (field instances) based on specific data values.

Instance IDs work like a dynamic Where clause and can be assigned to:

- *Records*: Select when the data that is mapped to the record is valid for only a subset of data within the primary PeopleSoft record. If the condition is not met, the record is not formatted. You can define instances for a specific ordinal row from a table or rows based on a value in a table.
- *Fields*: Select when you need to control which PeopleSoft values to use for the field. When the condition is met, a specified PeopleSoft value is mapped to the field.

See [Working with Transactions](#).

Interface Instance Table Page

Use the Interface Instance Table page (PI_INSTANCE_PNL) to set up instance IDs to filter PeopleSoft data that is mapped to Payroll Interface fields or records.

Navigation:

Set Up HCM, and then **Product Related**, and then **Payroll Interface**, and then **Interface Controls**, and then **Instance Table**, and then **Interface Instance Table**

This example illustrates the fields and controls on the Interface Instance Table page.

Interface Instance Table

System ID CSV CSV Sample Layout
InstanceID SALARY

Definition Find | View All First 1 of 1 Last

Effective Date: 01/01/1980 Description: Salaried Employees

Short Description: Salaried *Instance Indicator: Value

PeopleSoft Record Name: JOB PeopleSoft Field1 Name: EMPL_TYPE

Include Exclude Indicator: Include Values

Instance Information Personalize | Find | View All First 1 of 1 Last

*Sequence	Field1 Value
1	S

Definition

Field or Control	Description
Instance Indicator	Select either: <ul style="list-style-type: none"> <i>Value</i>: Controls selection according to the value in a field. <i>Deduction Class</i> is an example. The specified values indicate which condition must be met for the system to select data for processing. <p>Note: Use the word <i>ZERO</i> to specify that the value should be compared to the number 0.</p> <i>Ordinal</i>: Controls selection according to the occurrence of data or entry within a table. For example, in PeopleSoft, an employee can have several entries within the Direct Deposit Distribution Table. An ordinal instance type tells Payroll Interface which occurrence or row of data within the PeopleSoft record to select for export.
PeopleSoft Record Name and PeopleSoft Field1 Name	Select to identify the PeopleSoft record and PeopleSoft field that are tested against the specified values.
Include Exclude Indicator	Select to include or exclude the value when it matches the condition that you specified.

Instance Information

Field or Control	Description
Sequence	Select to indicate which occurrence or entry in the PeopleSoft record to use for processing. The sequence order is dictated by the select order on the primary PeopleSoft table used to define the interface ID field or record. <p>When using an ordinal instance type, Payroll Interface selects only the occurrence that corresponds to the row number from the PeopleSoft record defined for export.</p>
Field1 Value	Select to indicate a value to use during processing. <p>To create an instance ID based on the value of zero, use the literal value ZERO instead of 0.</p> <p>To create an instance ID based on the value of space, use the literal value SPACE instead of pressing the space bar.</p>

Setting Up the Process Table

To set up the Process Table, use the Process Table (INTRFC_PROCESS) component.

Page Used to Set Up the Process Table

Page Name	Definition Name	Usage
Interface Process Table Page	PI_PROCESS_PNL	Set up a COBOL process.

Understanding the Process Table

Use the Process Table component to access the COBOL processes that are delivered with Payroll Interface. These processes enable transaction processing or other types of processing such as data translation or data formatting.

You can add your own COBOL routines to the system. You can also document and control which user exit program is called for any process that you define and describe any changes that you make to the provided processes.

Interface Process Table Page

Use the Interface Process Table page (PI_PROCESS_PNL) to set up a COBOL process.

Navigation:

Set Up HCM, and then **Product Related**, and then **Payroll Interface**, and then **Interface Controls**, and then **Process Table**, and then **Interface Process Table**

This example illustrates the fields and controls on the Interface Process Table page.

Interface Process Table

The screenshot displays the 'Interface Process Table' page. At the top, there is a 'Process Details' section with the following fields and controls:

- Process ID:** 000003
- 'PI Process Phase':** A dropdown menu set to 'Before Field Translation'.
- 'Type':** A dropdown menu set to 'Field'.
- User Defined Process:** A checked checkbox.
- Short Description:** A text field containing 'City Code1'.
- User Exit Program:** A text field containing 'PIPSPADP'.
- Process Description:** A text area containing the text: 'This process will return the Locality Code for the City 1 field. If the employee has more than one Locality Code defined, the Locality Code returned is the Locality Code where they work.'

Below the process details is a 'Returned Values' table with the following structure:

Returned Value	Description

Process Details

Field or Control	Description
Process ID	<p>Select the process ID for one of the delivered COBOL processes or enter a process ID for your own COBOL routine.</p> <p>See Reviewing Delivered COBOL Processes.</p> <p>If you create your own COBOL routine, you must set up a process ID for the routine using this page.</p> <p>See Creating COBOL Routines.</p>
PI Process Phase	<p>Select to identify when the system runs the COBOL process. A process phase is hard-coded into each COBOL process that is delivered with Payroll Interface; if you change the process phase, you must also modify the COBOL process.</p> <p>A process ID can have more than one PI process phase attached to it. The following are translate values for PI process phase:</p> <ul style="list-style-type: none"> • <i>After Field Translation</i> • <i>Before Field Translation</i> • <i>Export File Creation</i> • <i>Import Processing</i> • <i>Record Processing</i>
Type	Select to indicate whether the process applies to a record or a field.
User Defined Process	Select if the process is one that you have defined or it is delivered with this turned on.
User Exit Program	If User Defined Process is selected, select to specify the name of the user-defined program that will transfer the control to run the process. A value of space characters indicates a common routine (PIPSPRCS) that is delivered with the Payroll Interface system.

Returned Values

Field or Control	Description
Returned Value	Applies only when the value for the PI Process Phase field is <i>Before Field Translation</i> .

Setting Up the File Handle Table

To set up the File Handle table, use the File Handle Table (INTRFC_FILEHANDLE) component.

Page Used to Set Up the File Handle Table

Page Name	Definition Name	Usage
Interface File Handle Table Page	PI_FLHANDLE_PNL	Assign a handle to each external file that is imported or exported.

Understanding the File Handle Table

Use the File Handle Table component to define file handles that identify the export or import files and their physical location on the computer system. File handles are connected to the file IDs, which are set up using the Definition Table component.

This diagram shows the relationship between file IDs and file handles:

This diagram shows the relationship between file IDs and file handles.

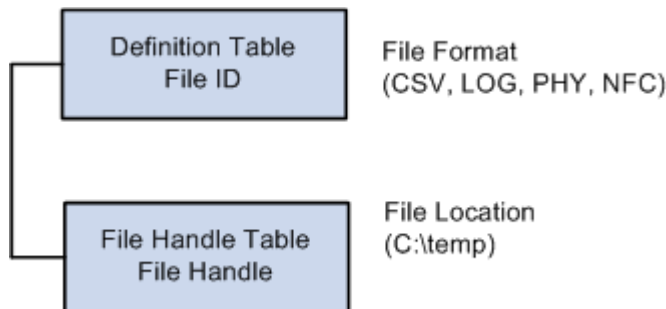

Interface File Handle Table Page

Use the Interface File Handle Table page (PI_FLHANDLE_PNL) to assign a handle to each external file that is imported or exported.

Navigation:

Set Up HCM, and then **Product Related**, and then **Payroll Interface**, and then **Interface Controls**, and then **File Handle Table**, and then **Interface File Handle Table**

This example illustrates the fields and controls on the Interface File Handle Table page.

Interface File Handle Table

Definition				Personalize Find View All [?] []		First	1-5 of 9	Last
File Handle	File Name	Description						
61	C:\temp\SEQOUT61	PACT						
62	C:\temp\SEQOUT62	PMSO						
C1	C:\TEMP\MASTER.CSV	Sample CSV Master File						
C2	C:\TEMP\DEDUCTION.CSV	Sample CSV Deduction File						
C3	C:\TEMP\BEFORE-TAX-SAVINGS.CSV	Sample Before Tax Savings File						

Field or Control	Description
File Handle	Select to enter any combination of two-digit alphanumeric characters, regardless of the external file's format. Each file handle number should be assigned a unique process type (export or import).
File Name	Select to enter the exact path and file name that corresponds to the file handle's location. Be sure to use the appropriate syntax for your operating system (Windows-based, Unix-based, and so on).

Setting Up the Configuration Table

To set up the Configuration table, use the Configuration Table (INTRFC_CONFIG) component.

Page Used to Set Up the Configuration Table

Page Name	Definition Name	Usage
Interface Configuration Table Page	PI_CONFIG_PNL	Set up configuration IDs and link file IDs to file handles.

Understanding the Configuration Table

Use the Configuration Table component to define a configuration ID. The configuration ID is the connection mechanism that joins PeopleSoft HCM to the third-party payroll system and enables the exchange of data.

This diagram shows that the configuration ID connects the file ID to the file handle:

This diagram shows that the configuration ID connects the file ID to the file handle.

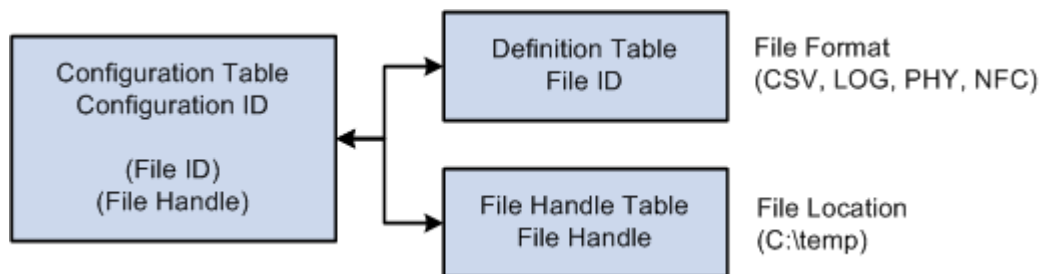

This diagram shows that the configuration ID also connects the PeopleSoft HCM pay group to the third-party payroll system:

This diagram shows that the configuration ID also connects the PeopleSoft HCM pay group to the third-party payroll system.

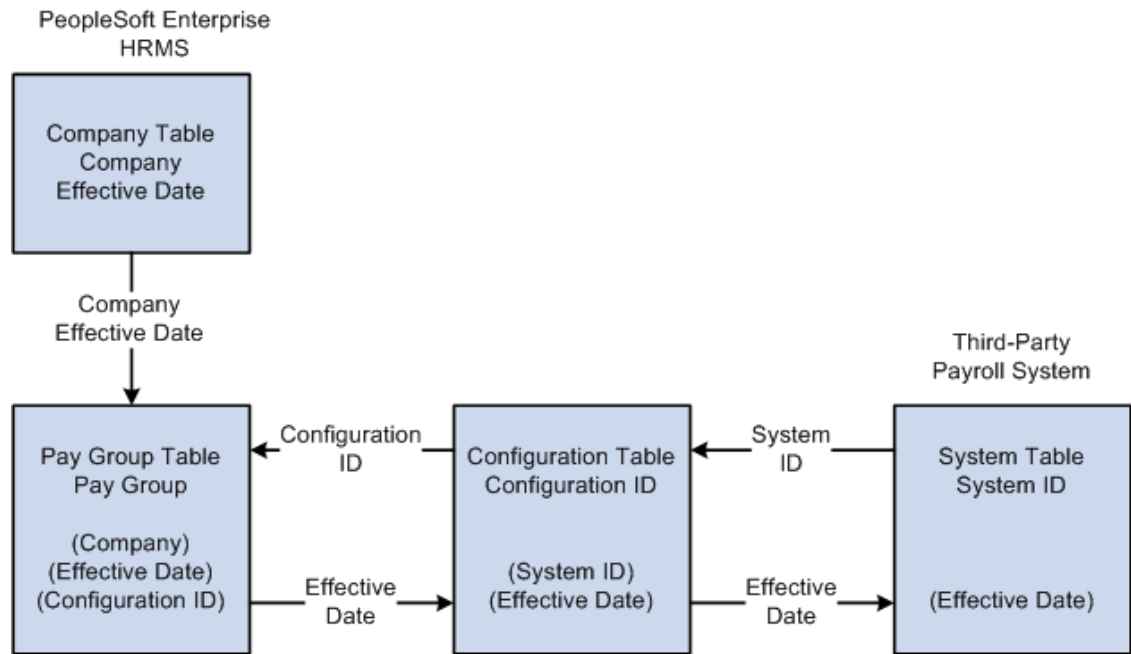

Note

The configuration ID is entered on the Pay Group Table - Definition page, **PI Configuration ID** field and is used to identify the payroll system and the interface files that apply to the pay groups.

Related Topics

- [Understanding Payroll Schedules](#)
To track and export changes that occur to employee-level payroll data, you run the Payroll Interface processes at least once each pay period using the payroll schedules that you establish in PeopleSoft HCM.

Interface Configuration Table Page

Use the Interface Configuration Table page (PI_CONFIG_PNL) to set up configuration IDs and link file IDs to file handles.

Navigation:

Set Up HCM, and then **Product Related**, and then **Payroll Interface**, and then **Interface Controls**, and then **Configuration Table**, and then **Interface Configuration Table**

This example illustrates the fields and controls on the Interface Configuration Table page.

Interface Configuration Table

Config ID PHY

Definition Find | View All First 1 of 1 Last

'Effective Date 01/01/1980

'Status Active

Description Physical File Format

*System ID PHY Physical File Format

File IDs Personalize | Find | View All First 1 of 1 Last

File ID	Descr	File Handle	File Name
PHY <input type="button" value="🔍"/>	Physical File Layout	P1 <input type="button" value="🔍"/>	C:\TEMP\PHYSICAL.TXT <input type="button" value="+"/> <input type="button" value="-"/>

Field or Control	Description
System ID	Select to identify the system ID for the third-party payroll system.

File IDs

Use the options in the File IDs group box to link file IDs to file handles.

Field or Control	Description
File ID and File Handle	Select to identify the export file or import file and to specify each file's handle as defined using the File Handle Table component.

10

Setting Up a Payroll Interface Definition (Part 2)

Working with Interface Definitions

This topic discusses how to:

- (USF) Set up an NFC export interface definition.
- Set up a DETI import interface definition.
- Set up a new import interface definition.

(USF) Setting Up an NFC Export Interface Definition

Use the National Finance Center (NFC) sample data definition to set up an export interface for federal agencies, who primarily use the National Finance Center as the third-party payroll system.

Note

Federal agencies generally do not import NFC data (the processed payroll results) back into PeopleSoft HCM. You can configure Payroll Interface to import the data, but most agencies do not take advantage of this feature

Payroll Interface uses the NFC system ID as well as the Industry and Industry Sector codes set up in PeopleSoft HR to identify federal workers. Because the NFC sample data definition is configured to export position and job data, you should implement full position management within PeopleSoft HR.

The NFC sample data definition includes two export files: the Entry, Processing, Inquiry, Correction (EPIC) file contains employee data; the Position Management Data (PMSO) file contains position and job code data. Both files include the appropriate header information required by the NFC. When you export a full set of records, the NFC export sends only the last effective-dated row for both employee data and position and job code data.

The NFC sample data definition includes six additional tables (views):

Table	Description
GVT_PI_AWD_VW	SF50/52 award information for the NFC's 110 record.
GVT_PI_DATA_VW	The personal, employment, and job data that is used to process SF50/52 forms for the NFC's EPIC 063 Data record.
GVT_PI_EDUC_VW	Education information for the NFC's EPIC 063 Data record.

Table	Description
GVT_PI_RMKS_VW	SF50/52 remarks information for the NFC's Remark (RMK) record.
GVT_PI_POIP_VW	The NFC's PMSO Individual Position record (2056).
GVT_PI_POMR_VW	The NFC's PMSO Position Master record (2055).

Related Topics

- PeopleSoft Human Resources Administer Workforce: Understanding NFC Processing

Setting Up a DETI Import Interface Definition

Use the Detail Interface (DETI) sample data definition to set up an import interface definition that loads the employee check detail information produced by the third-party payroll system.

To set up the import interface, obtain a copy of the data file from the third-party payroll vendor that matches the DETI sample data definition. Then, examine the Payroll Interface fields and records that are associated with it:

1. Ensure that the key values that you map using the PI_CHECK table are the same values that are mapped on the three DETAIL child records, plus one more to make it a unique child.

You must also create a field definition for each data field that is present in the file, including a filler for unwanted data when the data is defined by its position in the record.

2. Define the import records.
3. Attach your file definition to the Payroll Interface configuration ID and define the external file handle to enable the COBOL program to find the input file.

For physical file types, some data fields may be defined according to type (such as OASDI tax type) by their position in the import record. As shown in this example, Payroll Interface reflects this tax type by creating a separate row for each occurrence and captures the tax type during import by attaching a group ID:

This example of the Interface Group Table page shows a sample Group ID used for import.

Interface Group Table

System ID CSV CSV Sample Layout

Group ID D03

Process Type Import

Description Soc Security Tax (OASDI)

Short Description OASDI

PeopleSoft Record Name PI_TAX_DETAIL

PeopleSoft Field1 Name PI_TAX_TYPE

PS Key Value OASDI

As shown in this example of the Interface Group Table page (**Set Up HCM**, and then **Product Related**, and then **Payroll Interface**, and then **Interface Controls**, and then **Group Table**, and then **Interface Group Table**), Payroll Interface uses the entry in the **PS Key Value** (PeopleSoft key value) field to populate the field defined in PeopleSoft Field1 Name with *OASDI*, as it builds the data for the record given by PeopleSoft Record Name from the import row being processed:

This example of the Interface Definition Fields page shows a sample interface definition used for import.

Interface Definition Fields										
File ID		File ID		Effective Date						
CSVDED		CSV - Ded_Calc - Sample File		01/01/1980						
Definition										
Rec Seq Nbr		Record ID								
10		PDED		Deduction Record						
PS Record DED_CALC										
Fields										
Field Sequence	Redefine	Field ID	Description	Start Position	Field Length	Field1 Name	Convert Case	Reverse Sign	Key Field	Group ID
10	<input type="checkbox"/>	C001	Company Code	1	3		<input type="checkbox"/>	<input type="checkbox"/>	Record Lev	
20	<input type="checkbox"/>	J001	Employee ID	4	11		<input type="checkbox"/>	<input type="checkbox"/>	Record Lev	
30	<input type="checkbox"/>	D001	Deduction Code	15	8	DEDCD	<input type="checkbox"/>	<input type="checkbox"/>	Occurrence	DED
40	<input type="checkbox"/>	D002	Deduction Amount	23	7	DED_CUR	<input type="checkbox"/>	<input type="checkbox"/>	Not a Key F	DED

This example of the Interface Definition Fields page (**Set Up HCM**, and then **Product Related**, and then **Payroll Interface**, and then **Interface Controls**, and then **Definition Table**, and then **Interface Definition Fields**), shows a sample interface definition used for import.

This example of the Interface Field1 page shows a sample field ID used for import.

As shown in this example of the Interface Field1 page (**Set Up HCM**, and then **Product Related**, and then **Payroll Interface**, and then **Interface Controls**, and then **Field Definition Table**, and then **Interface Field1**), group ID D03 is attached to the field ID DPD03.

Defining a New Import Interface Definition

This topic discusses how to set up a new import file definition. For this example, you use a physical, fixed-length data file to import pay period data into the PI_CHECK, PI_EARN_DETAIL, PI_DED_DETAIL, and PI_TAX_DETAIL import tables.

Basic File Layout

Header and footer records are optional. To use data that's not at the employee level, place it here. For examples, see the DETI sample data file header and footer.

Note

You can map fields that are derived from the PeopleSoft pay calendar or that are derived during the Payroll Interface process. At the field level, select *value* as the type, and view the text list.

Record Identifiers

For each physical record to be read, set up an interface field as a record flag. On the Interface Field 1 page, enter *value* in the **Type** field and *External Record Code* in the **Text** field. Then each record has a unique flag at the beginning of the input data record.

Sample Values

This table lists sample values:

Default Value	Record Name	Field Name
A	PI_CHECK	CHK01
B	PI_EARN_DETAIL	ERN01
C	PI_DED_DETAIL	DED01

Default Value	Record Name	Field Name
D	PI_TAX_DETAIL	TAX01

Record Key Fields

Examine each PeopleSoft system record definition into which you want to import data. Examine the DETI sample data file and ensure that you map the same key fields from the data file into the Payroll Interface tables, as a minimum.

Sample Data File Layout

Each record is physical, with a fixed length, but the records do not have to be the same length. Enter the longest record length on the Definition Table component - Interface Definition File page, **PI Record Length** field.

Record A: Contains PI_EMPLID and all other data fields that are mapped to PI_CHECK. Key record fields are:

- CHK01
- Check Number
- PI_EMPLID, as defined on the System Table component - Interface System Table 1, **Employee Field ID** field.

Record B, C, D, and subsequent records: These records do not need the **PI_EMPLID** field. The Import process uses the same Payroll Interface employee ID for these data records until it reads another record A with another Payroll Interface employee ID.

To process multiple records repeatedly, set the Definition Table component - Interface Definition Record page, **Occur Ind** field to *Multi Recs to Single Defn Rec*. For an example, see the DETI sample data file, Record ID DPE, Coded Hours.

Record B (Earn Detail)

ERN01 (RECORD)

Earn Type (NON KEY)

Earn Code (NON KEY)

Amount (NON KEY)

The data file might look like this:

A, Emplid, check nbr, data field, data field, etc.

B , earn type, code, amount

B, earn type, code, amount

B , earn type, code, amount

B, earn type, code, amount

Each subsequent record repeats many times as necessary (using Multi Recs to Single Defn Rec).

Record C (Deduction Detail)

DED01 (RECORD)

Ded Code (NON KEY)

Ded Amount (NON KEY)

The data file might look like this:

A, Emplid, check nbr, data field, data field, etc.

B , earn type, code, amount

B, earn type, code, amount

B , earn type, code, amount

B, earn type, code, amount

C, code, amount

C, code, amount

C, code, amount

C, code, amount

C, code, amount

C, code, amount

The PeopleSoft system imports subsequent records in the same way.

Working with Character Sets

Use the System Table component - Interface System Table 1 page, **Character Set** field to select a character set for export or import processing.

See [Setting Up the System Table](#).

The following table lists the character sets that Payroll Interface supports.

For example, suppose your headquarters is in the U.S., but you have an office in Japan where the payroll system uses Kanji. When Payroll Interface is run for the U.S., the **Character Set** field is set to *ISO 8859-1*, the Latin character set. When Payroll Interface is run for the Japanese site, the **Character Set** field must be set to *JIS X 0208*, the Kanji character set.

Character Set	Description
ANSI	Current ANSI Code Page
ASCII	US 7-bit ASCII
Big5	Big5 (Traditional Chinese)
CCSID1027	IBM EBCDIC 1027 (Jap.-Latin)
CCSID1047	IBM EBCDIC 1047 (Latin1)
CCSID290	IBM EBCDIC 290 (Katakana)
CCSID300	IBM EBCDIC 300 (Kanji)
CCSID930	IBM EBCDIC 930 (Kana-Kanji)
CCSID935	IBM EBCDIC 935 (Simplified Chinese)
CCSID937	IBM EBCDIC 937 (Traditional Chinese)
CCSID939	IBM EBCDIC 939 (Latin-Kanji)
CCSID942	IBM EBCDIC 942 (Japanese PC)
CP1026	Windows 1026 (EBCDIC)
CP1250	Windows 1250 (Eastern Europe)
CP1251	Windows 1251 (Cyrillic)
CP1252	Windows 1252 (Latin1)
CP1253	Windows 1253 (Greek)
CP1254	Windows 1254 (Turkish)
CP1255	Windows 1255 (Hebrew)
CP1256	Windows 1256 (Arabic)
CP1257	Windows 1257 (Baltic)
CP1258	Windows 1258 (Vietnamese)
CP1361	Windows 1361 (Korean Johab)
CP437	MS-DOS 437 (US)
CP500	Windows 500 (EBCDIC 500V1)
CP708	Windows 708 (Arabic - ASMO708)
CP720	Windows 720 (Arabic - ASMO)
CP737	Windows 737 (Greek - 437G)
CP775	Windows 775 (Baltic)
CP850	MS-DOS 850 (Latin1)
CP852	MS-DOS 852 (Latin2)
CP855	MS-DOS 855 (IBM Cyrillic)
CP857	MS-DOS 857 (IBM Turkish)
CP860	MS-DOS 860 (IBM Portuguese)
CP861	MS-DOS 861 (Icelandic)
CP862	MS-DOS 862 (Hebrew)
CP863	MS-DOS 863 (Canadian French)

Character Set	Description
CP864	MS-DOS 864 (Arabic)
CP865	MS-DOS 864 (Nordic)
CP866	MS-DOS 866 (Russian)
CP869	MS-DOS 869 (Modern Greek)
CP870	Windows 870
CP874	Windows 864 (Thai)
CP875	Windows 875 (EBCDIC)
CP932	Windows 932 (Japanese)
CP936	Windows 936 (Simplified Chinese)
CP949	Windows 949 (Korean)
CP950	Windows 950 (Traditional Chinese)
EBCDIC	IBM EBCDIC CCSID37 (USA)
EUC-JP	Extended Unix Code (Japanese)
EUC-KR	Extended Unix Code (Korean)
EUC-TW	Extended Unix Code (Taiwan)
EUC-TW-1986	Extended Unix Code (TW-1986)
GB12345	GB 2312 (Simplified Chinese)
GB2312	GB 2312 (Simplified Chinese)
ISO-2022-JP	ISO-2022-JP Japanese
ISO-2022-KR	ISO-2022-JP Korean
ISO_8859-1	ISO 8859-1 (Latin1)
ISO_8859-10	ISO 8859-10 (Latin6)
ISO_8859-11	ISO 8859-11 (Thai)
ISO_8859-14	ISO 8859-14 (Latin8)
ISO_8859-15	ISO 8859-15 (Latin9 / Latin0)
ISO_8859-2	ISO 8859-2 (Latin2)
ISO_8859-3	ISO 8859-3 (Latin3)
ISO_8859-4	ISO 8859-4 (Latin4)
ISO_8859-5	ISO 8859-5 (Cyrillic)
ISO_8859-6	ISO 8859-6 (Arabic)
ISO_8859-7	ISO 8859-7 (Greek)
ISO_8859-8	ISO 8859-8 (Hebrew)
ISO_8859-9	ISO 8859-9 (Latin5)
JIS_X0201	Japanese Half-width Katakana
JIS_X_0208	Japanese Kanji
Java	Java (Unicode encoding)
Johab	Johab (Korean)
Shift_JIS	Shift-JIS (Japanese)
UCS2	Unicode UCS-2
UTF7	Unicode UTF-7

Character Set	Description
UTF8	Unicode UTF-8

Working with Text Translate Values

Use the Field Definition Table component - Interface Field1 page, **Text** field to select translate values.

See [Setting Up the Field Definition Table](#).

Translate values correspond to data elements that are already available to the COBOL process. The following table lists the field values, their translate values, and where the data originates.

Value	Translate Value	Source
B	Pay Period Begin Date	PAY_CALENDAR.PAY_BEGIN_DT
C	Constant	PI_FIELD_TBL.PI_DFLT_VALUE
D	Compare Date	PI_RUN_PYGRP.COMPARE_DTTM
E	Export Date	System date at runtime
F	PI Config ID	PAYGROUP.PI_CONFIG_ID
G	Termination Count	Process Calculation
H	Hire count	Process Calculation = Hired this run
I	External Record Code	PI_DEFN_RECORD.PI_RECORD_ID
L	Logical Record Count	Process Calculation
M	Société de Traitement	(Processing Paygroup) Derived during Processing
N	Interface Run Number	PI_RUN_TBL.PI_RUN_NUM
O	Process Option	PI_RUNCTL.PI_RUN_OPT
P	Pay End Date	PAY_CALENDAR.PAY_END_DT
Q	Check Date	PAY_CALENDAR.PAY_CHECK_DT
R	Pay Run ID	PI_RUN_CTL.RUN_ID
S	System ID	PI_CONFIG_TBL.PI_SYSTEM_ID
T	Compare Time	PI_RUN_PYGRP.COMPARE_DTTM
U	Lot de Paie de Traitement	(Processing Company) Derived during Processing
X	Export Time	System Date Time value at runtime
Y	Physical Record Count	Process Calculation

Working with Company Filtering

Use the Definition Table component - Interface Definition Fields page, **Key Field** field to select *Company* as the key field.

See [Setting Up the Definition Table](#).

Company filtering restricts Payroll Interface processing to a single company. With company filtering, the *Company* value that is assigned to a particular row of data must be the same as the company that you are processing for the row to be formatted and passed to the interface. If company filtering is not used, all rows created by Payroll Interface for each company and pay group combination are available for export.

For example, in PeopleSoft, you indicate that an employee has transferred from one company to another by adding a new JOB row with the Transfer action. In some third-party payroll systems, however, the company is part of the employee key; therefore, when an employee transfers to another company, Payroll Interface creates a new employee dossier (pool of data). For the transferred employee, you issue a termination on the old company and a hire on the new company.

After a transfer occurs, the system creates two images within Payroll Interface, one for each company. With company filtering, a change in employee data may apply to both images (the case for personal data rows, which would not have *Company* as a key field). In other cases, it may apply to one image (such as JOB row data, which you would generally want to filter by company). You can track retroactive changes even if the changes pertain to a company that the employee has already left. If you had not used company filtering, the third-party payroll system would store one set of transactions, without creating separate dossiers and without redundant data (like personal data rows).

This graphic shows how company filtering maps an employee's company data into separate files:

This diagram shows how company filtering maps an employee's company data into separate files.

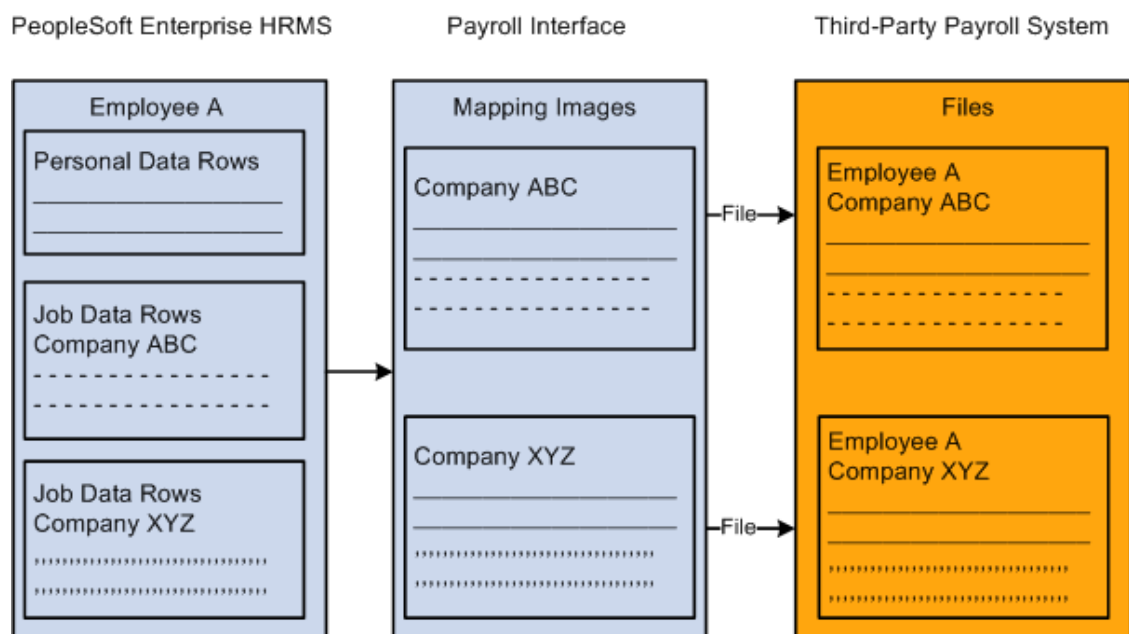

This example shows a worker employed in multiple companies over a period of five years. Assume that only one pay group exists per company.

Company	Effdt	Comprate
CCB	01-01-1999	500
CCB	01-01-1998	450
PST	01-01-1997	425
PST	01-01-1996	400
CCB	01-01-1995	325

If you change data in the 1995 row, you must send the data to company CCB. If you change the 1997 row, you send the data to company PST.

To implement company filtering:

1. Select *Company* for the System Table component, Interface System Table 1 page, Process Filter field.
2. Select *Company* for the Definition Table component - Interface Definition Fields page, **Key Field** field for those records that will be filtered by company.
3. For the company fields, use either a constant value equal to the processing company (used for personal data) or use the company from the Job Data component (or from a view based on the tables underlying the Job Data component).

Note

The system compares the field that is mapped as company to the processing company only after translation.

Working with Key Fields

Use the Definition Table component - Interface Definition Fields page, **Key Field** field to define a field as an occurrence (*Occurrence*) key or and effective-date(*Effdt*) key.

See [Setting Up the Definition Table](#).

When you define a field as an occurrence key, multiple records (rows) are formatted for export. When you define a field as an effective-date key, the retrieved data is put through an extra process to eliminate redundant records (rows) from the PI_PARTIC_EXPT table.

For example, suppose the Job Data table contains the data shown in this table:

Effective Date	Effective Sequence	Comprate	Department ID
1999-01-15	0	100	00100
1998-12-12	0	100	00200
1998-12-10	0	85	00200
1997-06-10	0	85	00300
1997-05-31	0	75	00400

If you define the Effective Date field as an occurrence key, the following data is formatted for export:

Effective Date	Comprate
1999-01-15	100
1998-12-12	100
1998-12-10	85
1997-06-10	85
1997-05-31	75

If you define the Effective Date field as an effective-date key, the following data is formatted for export:

Effective Date	Comprate
1998-12-12	100
1997-06-10	85
1997-05-31	75

Warning

Accurate processing depends on the collate order that you specify for the effective-dated field. On the PS Tables component - PS Tables page, **Collate Order** field, you must select *Asc* (ascending). If you do not select the ascending collate order, you will eliminate all but the last row.

Working with COBOL Processes

This topic discusses how to:

- Review delivered COBOL processes.
- Review delivered COBOL processes for special events.
- Create COBOL routines.

Reviewing Delivered COBOL Processes

Use the Process Table component - Interface Process Table page, **Process Description** field to review descriptions of the COBOL processes that are delivered with Payroll Interface.

The delivered COBOL processes are either field or record processes (you can associate a process with either a field or a record) that perform processing tasks outside the normal scope of Payroll Interface.

See [Setting Up the Process Table](#).

Example: Process ID 000015

This COBOL process performs a validation against some data values and sets the value of the field to which the process is attached to one of the values listed in the Interface Process Table page, **Returned Value** field. Because the timing is Before Field Translation, you can then use

these values in the Field Translation list. The list of values in the **Returned Value** field documents the process so that you know which values can be used in the Field Translation list and what they represent. This technique enables you to leverage one COBOL routine for two fields.

This process is useful because the PeopleSoft system stores certain tax values in two separate fields: one field for percents and another field for flat amounts. For this type of field, some payroll systems have one field with a Type code to specify whether it is a percent or an amount. The COBOL process determines which PeopleSoft field contains the value and returns those fields that are equal to the one identified in the **Returned Value** field. The Payroll Interface process then converts or translates the value in the **Returned Value** field to another value based on the Field Translation list.

Delivered Processes

This table lists and describes the COBOL processes that are delivered with PeopleSoft Payroll Interface:

Process ID	Process Phase	Description	Type	User Defined Process	User Exit Program	Description
000001	Record Processing	Ded End Dt	Record	No	None	When the primary PeopleSoft source for the transaction is additional earnings, matches the earnings end date against the pay end date to determine whether the additional earnings should be stopped.
000002	Before Field Translation	Area Code	Field	No	None	Extracts the U.S. area code from the phone number field if the field contains 10 characters. If the field contains fewer than 10 characters, spaces are returned.
000003	Before Field Translation	City Code1	Field	Yes	PIPSPAD P	Returns the locality code for the City 1 field. If the employee has more than one locality code defined, the code returned is where he or she works.

Process ID	Process Phase	Description	Type	User Defined Process	User Exit Program	Description
000004	Before Field Translation	City Code2	Field	Yes	PIPSPAD P	Uses the City2 Code value only if resident state and work state are different. Uses the translate entries when needed.
000005	Before Field Translation	Cnt Deduct	Field	Yes	PIPSPAD P	Adds 1 to a counter for deductions using fields that are mapped to the ON1 field. Issues a warning message when the employee has more than 24 deductions.
000005	Export File Creation	Tilde Chr	Field	No	None	For delimited data file structures only. Inserts a Delete character as defined in the working storage of the COBOL program PIPXPRCS.CBL A tilde (~) follows the value of the field to be deleted. Only works when invoked from a Process Control record definition.

Process ID	Process Phase	Description	Type	User Defined Process	User Exit Program	Description
000006	Record Processing	Co change	Record	No	None	Recognizes that the PeopleSoft company ID for this employee has changed. When using this process, the PeopleSoft company ID must be mapped to a field within the record. If the converted value for the PeopleSoft company ID changes, the record containing this process ID is formatted.
000008	After Field Translation	Excess	Field	Yes	PIPSPAD P	Returns the translated deduction code for the direct deposit bank account identified to contain the "excess" within PeopleSoft.
000008	Export File Creation	Skip Blank	Field	Yes	PIPXPAD P	Bypasses this field in the output file if the Export Full option is selected and the field is blank.
000009	Before Field Translation	Lcl recip	Field	Yes	PIPSPAD P	Creates values to apply to the translate table. If Local 2 exists, then Field 1 will be resident local and Field 02 will be work local.
000010	Before Field Translation	First Name	Field	No	None	Extracts the first name from the PeopleSoft Name field on the Personal Data Table.

Process ID	Process Phase	Description	Type	User Defined Process	User Exit Program	Description
000011	Before Field Translation	Last Name	Field	No	None	Extracts the last name from the PeopleSoft Name field on the Personal Data Table.
000012	After Field Translation	New Hire	Field	Yes	PIPSPAD P	Sets the new hire action to a lowercase <i>N</i> . This is set when no history records exist for the employee.
000013	Before Field Translation	Old PI ID	Field	No	None	Uses the employee's previous PI_EMPLID.
000014	Before Field Translation	Before Field Translation	Field	No	None	Maps the previous export value for this field into the current record.
000015	Before Field Translation	Pct or Amt	Field	No	None	Derives a type code from data in two related numeric fields. The first is the amount; the second is the percent. Both fields must be on the same table and row. The return values reflect non-zero entries in the fields. Examples include Federal Tax Data, Additional Amount, and Additional Percent.
000016	Export File Creation	Bypass Rec	Record	No	None	Bypasses the entire record on the output file.
000016	Import Processing	Bypass Rec	Record	Yes	PIPMPA DP	Validates and bypasses the record during the import process.

Process ID	Process Phase	Description	Type	User Defined Process	User Exit Program	Description
000017	Before Field Translation	Phone No	Field	No	None	Extracts the 7-digit phone number from the free-form Phone field.
000018	Record Processing	Pygrp chg	Record	No	None	Recognizes that the PeopleSoft pay group for this employee has changed. When using this process, the PeopleSoft pay group must be mapped to a field within the record. If the translated value for the PeopleSoft pay group changes, the record containing this process ID is formatted.
000019	After Field Translation	Rehire Cd	Field	Yes	PIPSPAD P	If the employee's status code was terminated the last time this employee's data was exported, but the current status code is Active, sets the Rehire code.
000020	Before Field Translation	RmSlsh/Dsh	Field	No	None	Returns the data value from the PeopleSoft database minus any embedded slashes or dashes. Use to return the U.S. ZIP code value without the separating dash and to return a phone number without dashes.

Process ID	Process Phase	Description	Type	User Defined Process	User Exit Program	Description
000021	Before Field Translation	State 2 Cd	Field	Yes	PIPSPAD P	Uses the Resident State Code if resident state and work state are different. Uses the translate entries when needed.
000022	Before Field Translation	Std Hours	Field	No	None	Calculates standard hours per pay period from standard weekly hours and pay frequency of the pay group.
000023	Record Processing	Stop DirDp	Record	No	None	Recognizes that the Direct Deposit code no longer applies for this employee. The record containing this process ID is formatted.
000024	Record Processing	Stop AdPay	Record	No	None	Recognizes that Additional Payment no longer applies for this employee. The record containing this process ID is formatted.
000025	Before Field Translation	Stop Code	Field	No	None	Returns a Yes indicator (a returned value of "Y") when one of the following events occurs: Stop Deduction, Stop Direct Deposit, Stop Additional Pay, PI Employee ID change, Company change or Pay Group change.

Process ID	Process Phase	Description	Type	User Defined Process	User Exit Program	Description
000026	Record Processing	Stop Ded	Record	No	None	Recognizes that the deduction code no longer applies for this employee. The record containing this process ID is formatted.
000027	Record Processing	Stop Goals	Record	No	None	Recognizes that deduction goals no longer apply for this employee. The record containing this process ID is formatted.
000028	Before Field Translation	Stop Date	Field	No	None	Returns a stop date when any of the following events occur: Stop Deduction, Stop Direct Deposit, Stop Additional Pay, PI Employee ID change, Company change and Pay Group change. The date supplied is the pay begin date minus one day. If the event does not occur, spaces are supplied for the stop data.
000029	Record Processing	Stop Save	Record	No	None	Recognizes that the savings plan deduction no longer applies for this employee. The record containing this process ID is formatted.

Process ID	Process Phase	Description	Type	User Defined Process	User Exit Program	Description
000030	Before Field Translation	ST Recip	Field	Yes	PIPSPAD P	Creates values to apply to the translate table. If State 2 exists, then Field 1 is the resident state and Field 2 is the work state.
000031	Record Processing	Transfer	Record	Yes	PIPSPAD P	Detects when the transfer transaction should be formatted.
000031	Export File Creation	Transfer	Record	Yes	PIPXPAD P	Recognizes when the PI_EMPID for an employee has changed. The transfer transaction is generated to include the appropriate change indicators for the fields that have changed.
000032	Before Field Translation	MD Local %	Field	No	None	Calculates the Maryland locality percentage. Translate values apply only when State 1 is Maryland.
000033	After Field Translation	SUI/SDI	Field	Yes	PIPSPAD P	Generates an error message and does not export the employee's data to ADP if a change is detected in this field and the employee has not been assigned a new PI_EMPLID. Use to validate a change to the SUI/SDI state tax code.

Process ID	Process Phase	Description	Type	User Defined Process	User Exit Program	Description
000034	Before Field Translation	> 3 DirDep	Field	Yes	PIPSPAD P	Edits the employee data for more than three direct deposit accounts.
000035	After Field Translation	New PI ID	Field	No	None	Uses the current or "new" PI-EMPLID when the old PI_EMPLID is not the same as the current PI_EMPLID assigned to the PeopleSoft employee ID.
000036	Import Processing	DPA09	Field	Yes	PIPMPA DP	Saves pay date 1 from the Direct Pay header record for access by process 000040.
000037	Import Processing	DPA10	Field	Yes	PIPMPA DP	Saves the pay period end date 1 from the Direct Pay header record for access by process 000040.
000038	Import Processing	DPA11	Field	Yes	PIPMPA DP	Saves the pay date 2 from the Direct Pay header record for access by process 000040.
000039	Import Processing	DPA12	Field	Yes	PIPMPA DP	Saves pay period end date 2 from the Direct Pay header record for access by process 000040.
000040	Import Processing	DPB11	Field	Yes	PIPMPA DP	Selects pay dates 1 or 2 from the Direct Pay header record. PI_CHECK key fields are based upon the value of this field.

Process ID	Process Phase	Description	Type	User Defined Process	User Exit Program	Description
000041	Import Processing	PCX 3E8	Field	Yes	PIPMPA DP	Updates PI-BALANCE_YEAR, PI_BALANCE_PERIOD and PI_BALANCE_QUARTER based upon the as of date.
000042	Import Processing	PCX 3E9	Field	Yes	PIPMPA DP	Updates all of the current employee's balance entries before they are inserted in the database.
000043	After Field Translation	Goal Amts	Field	Yes	PIPSPAD P	Paired with special process 000044. Does not send the goal limit amount if it is zero on setup. Formats the reset of a goal limit amount to zero when needed.
000044	After Field Translation	Goal Code	Field	Yes	PIPSPAD P	Pairs the Goal Limit codes with the Goal Limit Amount.
000045	Before Field Translation	Middle Int	Field	No	None	Retrieves the person's middle initial from the Name field. Names are entered last name, first name, and middle name. This routine takes the first character following the space after the first name.
000046	Before Field Translation	Middle Nme	Field	No	None	Retrieves the person's middle name from the Name field.

Process ID	Process Phase	Description	Type	User Defined Process	User Exit Program	Description
000047	Export File Creation	Skip Field	Field	Yes	PIPXPAD P	Causes the export process to bypass the field on the output file when the Export Full option is used and the field is blank.
000048	Export File Creation	Bypass Fld	Field	No	None	Bypasses the field in the output transaction file.
000049	Record Processing	Eff Status	Record	No	None	Checks the effective status field. If it is not active, the data will not be formatted for export.
000050	Record Processing	CSV	Record	Yes	PIPSRCS	Marks records with a stop deduction as having a stop on the PI Partic Export.
000200	Before Field Translation	GVT Remark	Field	No	None	(USF only) Creates an array of remarks codes from the SF50 remarks for inclusion in EPIC Record.
000201	Before Field Translation	Tang Amt	Field	No	None	(USF only) If Tangible Benefits > 0 sets to "Y" else blank.
000202	Before Field Translation	Intang Amt	Field	No	None	(USF only) If Intangible Benefits > 0 sets to "Y" else blank.
000203	Export File Creation	Geo Code	Field	No	None	(USF only) Process GVT_GEOLOC_CD Code.
000204	Before Field Translation	Hire Date	Field	No	None	(USF only) Hire Date evaluation.
000205	Before Field Translation	Posn Title	Field	No	None	(USF only) Position Title Code/Description.

Reviewing Delivered COBOL Processes for Special Events

The Definition Table component - Interface Definition Record page, **Process ID** field enables you to access COBOL processes that signal special events (transactions) such as a Stop Deduction. These events set an indicator that can be used later by another special process indicator. The following table lists the processes that PeopleSoft Payroll Interface delivers for special events.

See [Setting Up the Definition Table](#).

Note

The processes listed in this topic are a subset of the COBOL processes that are delivered with Payroll Interface.

See [Reviewing Delivered COBOL Processes](#).

See [Working with Transactions](#).

Process ID	Description	Record Type	Special Event
00001	0N1 Change	Data	Used for logical file types. Assigned to data records for DED_CALC and savings.
000023	Stop DirDP	Process	Stops direct deposit.
000024	Stop AdPay	Process	Stops additional payment. Assigned the stop record.
000026	Stop Ded	Process	Stop deduction. Assigned the stop record.
000027	Stop Goals	Process	Stop deduction goal. Assigned the stop record.
000029	Stop Save	Process	Stop savings plan deduction. Assigned the stop record.
000050	Savings, Additional Pay	Data	Assigned to the data records for non-logical file formats (such as CSV) for additional pay and savings plan before and after tax. These record IDs must be named: "SAVE" for before-tax savings "SPAT" for after-tax savings "APAY" for additional pay

Creating COBOL Routines

You can create your own COBOL routines for use with Payroll Interface. The system isolates your COBOL routines from the delivered Payroll Interface COBOL processes and calls them by retrieving the name specified on the Process Table component - Interface Process Table page, **User Exit Program** field.

Shell programs for three user exit invocation points are provided with Payroll Interface. You can use these programs as templates for your COBOL routines:

- PIPMPOTH: For routines performed during the Import process.
- PIPSPOTH: For routines performed during the Export process select/compare phases.
- PIPXPOTH: For routines performed during the Export process create export file phase.

To define your own COBOL routine:

1. Make a copy of the shell program that is associated with the Payroll Interface process phase in which your special process routine will be performed.

Do not modify the shell programs. These programs are set up with all the necessary working storage and linkage section data elements already defined and should be preserved as modules for future development.

2. Change all references to the shell program name to the name of your new routine.

Follow the PeopleSoft naming convention to make it easier to identify the timing of your own routines. You should change the last three characters of the program name to the system ID for which the routine is written. For example, the ADP system ID has three routines: *PIPMPADP*, *PIPSPADP*, and *PIPXPADP*.

3. Select a process ID for your new routine.

Review copy member *PICPRCSW.CBL* and select an unassigned number between 80000 and 899999. These numbers will not be used by PeopleSoft development. Add an 88 level description for your new routine in the copy member. Code your program logic and compile your program.

4. Define your new routine to Payroll Interface by setting up a process ID using the Process Table component.

Note

For AS400 and Oracle/VMS platforms, you must specify the calls to your user exit programs in copy member *PICUEXIT.CBL*. Edit this copy member to add your new program in the appropriate place.

Related Topics

- [Setting Up the System Table](#)
To set up the System Table, use the System Table (SYSTEM_TABLE) component.
- [Setting Up the Process Table](#)
To set up the Process Table, use the Process Table (INTRFC_PROCESS) component.

Working with Smart Select

The Select Type field on the Import/Export Payroll Data component - Import/Export Payroll Data page has three options: *All Employees in Group*, *Manually Select*, and *Smart Select*. The Smart Select option provides substantial performance benefits by enabling you to process only those employees who have had online changes since the last time the Export process was run.

When deciding whether to use Smart Select, consider the following:

- Smart Select is recommended for use with very large companies.
- To activate Smart Select, you must add a PeopleCode function, UPDATE_SMARTSELECT, to each EMPLID-keyed table that is set up in the PS Tables component—including those EMPLID-keyed tables that are referenced indirectly through views.

When data changes in these tables, a record that includes the EMPLID and EMPL_RCD key fields, as well as the data change, is written to the PS_PI_PRESELECT table. When you run the Export process using the *Smart Select* option, Payroll Interface processes only those records in the PS_PI_PRESELECT table.

- Smart Select detects online changes only.

At least once per payroll cycle you should run the Export process with the *All Employees in Group* option selected to process records that have changes but do not have the PeopleCode function attached, or to process records that have changes that were made outside of the online system (for example, deduction calculations or a batch update to your employees).

Note

If you update employees other than online, but they represent only a small percentage of all employees, you can manually update the PS_PI_PRESELECT table for these employees and then run the Export process with the *Smart Select* option selected.

- Smart Select detects changes to EMPLID-keyed tables only. You should run the Export process with the All Employees in Group option selected whenever you change the Payroll Interface definition, change any tables referenced in the PS Tables component that is not keyed on the EMPLID field, or are processing a group of employees for the first time.

Activating Smart Select

Payroll Interface provides a PeopleCode function, UPDATE_SMARTSELECT, which tracks online changes and makes the information available to the Export process. To activate Smart Select, you must add this function to each EMPLID-keyed table that is referenced by the PS Tables component—including those EMPLID-keyed tables that are referenced indirectly through views. The example in this topic shows how to activate Smart Select for the Citizenship table (record). Follow these same steps to activate Smart Select for other EMPLID-keyed tables.

To activate the Smart Select code for the Citizenship table:

1. Start PeopleSoft Application Designer.
2. Select File, Open.

The Open Definition dialog box appears.

3. From the Open Definition dialog box, do the following:
 - For the **Definition** field, select Record.
 - For the **Name** field, enter CITIZENSHIP.
 - Select **Open**.

The CITIZENSHIP (Record) dialog box appears.

4. Select View, PeopleCode Display.

The CITIZENSHIP (Record) dialog box displays a grid.

5. For the EMPLID field, locate the SPo (SavePostChange) cell in the grid.

PeopleCode may or may not be indicated for the EMPLID field in the SPo cell.

6. Double-click the SPo cell to open the PeopleCode editor.

The CITIZENSHIP.EMPLID.SavePostChange (Record PeopleCode) dialog box appears.

7. For the EMPLID field, add the following PeopleCode:

```
Declare Function UPDATE_SMARTSELECT PeopleCode PI_PRESELECT.PI_SELECT_TYPE
FieldFormula;
```

8. For the EMPLID field, add the following PeopleCode:

- If EMPL_RCD is a field in the CITIZENSHIP table, add:

```
UPDATE_SMARTSELECT (EMPLID, EMPL_RCD, 'Y');
```

- If EMPL_RCD is not a field in the CITIZENSHIP table, add:

```
UPDATE_SMARTSELECT (EMPLID, 0, 'N');
```

Note

The 'Y' or 'N' at the end of the parameter list indicates whether EMPL_RCD exists in the record. If it does not exist, then all jobs for a multijob employee will be processed in the next Smart Select export.

9. Save the PeopleCode and the table (record).

This example shows the Citizenship table (record):

This example illustrates the fields and controls on the CITIZENSHIP table (record).

Num	Field Name	Type	FCh	FFo	RIn	RIc	RDe	RSe	SEd	SPr	SPo	SrI	SrS	Wrk	PPr
1	EMPLID	Char									✓				
2	DEPENDENT_ID	Char						✓							
3	COUNTRY	Char	✓		✓						✓				
4	CITIZENSHIP_STATUS	Char			✓				✓						
5	CITIZEN_SGP_SBR	SRec													

This example shows the PeopleCode that is required to activate Smart Select:

This example illustrates the fields and controls on the PeopleCode function UPDATE_SMARTSELECT.

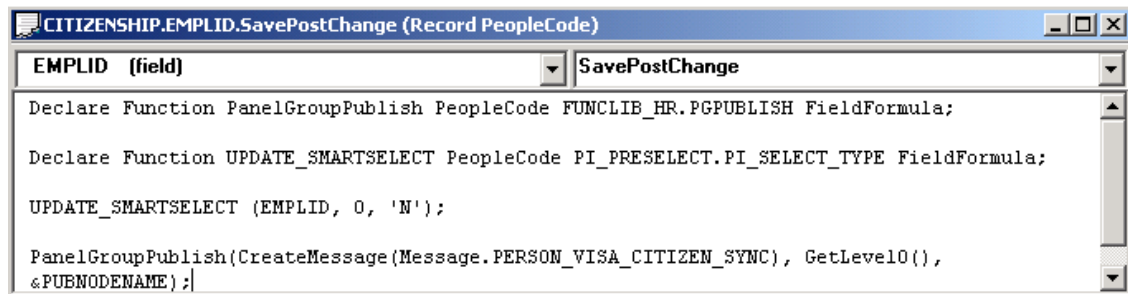

PeopleCode Function UPDATE_SMARTSELECT

The PeopleCode function UPDATE_SMARTSELECT tracks and records online data changes using the PS_PI_PRESELECT table.

```
Function UPDATE_SMARTSELECT(&EMPLID, &EMPL_RCD, &EMPL_RCDN_FLAG) &COUNT = 0;
SQLExec("SELECT COUNT(*) FROM PS_PI_PRESELECT WHERE EMPLID=:1 AND EMPL_RCD = :2
AND PI_SELECT_TYPE='C' AND PI_RUN_NUM= 0", &EMPLID, &EMPL_RCD, &COUNT); If &COUNT
> 0 Then SQLExec("UPDATE PS_PI_PRESELECT SET DATETIME_STAMP=%CurrentDateTimeIn
WHERE EMPLID=:1 AND EMPL_RCD = :2 AND PI_SELECT_TYPE='C' AND PI_RUN_NUM= 0",
&EMPLID, &EMPL_RCD); Else SQLExec("INSERT INTO PS_PI_PRESELECT
(PI_SELECT_TYPE,EMPLID,EMPL_RCD,DATETIME_STAMP, EMPL_RCDN_FLAG,PI_RUN_NUM) VALUES
('C',:1,:2,%CurrentDateTimeIn,:3,0)", &EMPLID, &EMPL_RCD, &EMPL_RCDN_FLAG); End-
If; End-Function;
```

Working with Transactions

This topic provides an overview of transactions and discusses how to:

- Set up a transaction.
- Set up a stop transaction.
- Verify a transaction.
- Verify a stop transaction.

Understanding Transactions

The LOG sample data that is delivered with Payroll Interface includes transactions and corresponding stop transactions for deductions, savings plans, and additional pay. This topic describes how to set up the transaction and the stop transaction for deductions using the LOGEXP export file.

When setting up transactions, the implementation details will vary depending on the type of transaction and the requirements of the third-party payroll system. The following procedures, however, show which Payroll Interface components need to be defined.

To set up a transaction:

1. Set up the PS Tables component—identify the tables and fields that are required for the transaction.

2. Set up the Field Definition Table component—define the fields that will be included in the export file.
3. (Optional) Set up the Instance Table component—create an instance ID if you want to restrict or modify the data that is sent to the third-party payroll system.
4. Set up the Definition Table component—define the transaction record and field sequences.

To set up a stop transaction:

1. Set up the Field Definition Table component—define the fields that will be included in the export file.
2. Review the Process Table component—identify the COBOL process that will perform the stop transaction.
3. Set up the Definition Table component—define the stop transaction record and field sequences.

Setting Up a Transaction

Follow these steps to set up a deduction transaction using the LOGEXP export file.

Step 1: Set Up the PS Tables Component

Identify the PeopleSoft tables and fields that store the data that is required for the transaction:

- Table: DED_CALC.
- Fields: DEDCD (deduction code), DED_CLASS (deduction class), and DED_CUR (deduction amount).

Use the PS Table (PI_PSREC_PNL) page to set up the PeopleSoft table and fields:

Navigation:

Set Up HCM, and then **Product Related**, and then **Payroll Interface**, and then **Interface Controls**, and then **PS Tables**, and then **PS Table**

This example illustrates the fields and controls on the PS Tables page for Step 1: Set Up the PS Tables Component.

PS Tables

Details
Find | View All
First 1 of 1 Last

System ID LOG Logical File Sample + -

Record (Table) Name DED_CALC

Description

'Process Type' Export

'Where Clause Type' ID, EffDt = Pay End Dt

Paygroup Company in Where
 Data Required
 Paygroup Country in Where
 Job Data
 Ded Calc Data

Field Details		Personalize Find View All					First 1-3 of 11 Last
Field Attribute Button	Field Name	Order by	Collate Order	Key Field	Effective Date	Effective Sequence	
Field Attribute Button	BENEFIT_PLAN	<input type="text"/>		<input checked="" type="checkbox"/>	<input type="checkbox"/>	<input type="checkbox"/>	
Field Attribute Button	CALCULATED_BASE	<input type="text"/>		<input type="checkbox"/>	<input type="checkbox"/>	<input type="checkbox"/>	
Field Attribute Button	COMPANY	<input type="text"/>		<input checked="" type="checkbox"/>	<input type="checkbox"/>	<input type="checkbox"/>	

Step 2a: Set Up the Field Definition Table Component, Export File Fields

Define the fields for the deduction transaction: DEDAMT (shown in the following example) and DEDCD (not shown).

The default value for DEDAMT is the calculated deduction amount. The default value for DEDCD is the deduction code.

Note

The DED_CLASS field, identified in the PS Tables component, is not included in the export file. However, an instance ID for this field is set up in step 3.

Use the Interface Field1 page to set up the field definition for the DEDAMT field.

Navigation:

Set Up HCM, and then **Product Related**, and then **Payroll Interface**, and then **Interface Controls**, and then **Field Definition Table**, and then **Interface Field1**

This example illustrates the fields and controls on the Interface Field1 page for Step 2a: Set Up the Field Definition Table Component, Export File Fields.

Interface Field1 | Interface E_jeld2

System ID LOG Logical File Sample Field ID DEDAMT

Field Definition Find | View All First 1 of 1 Last

Effective Date 01/01/1980 Description Deduction Amount Status Active

External Field ID AMOUNT Short Desc Ded Amount

Type Signed Number Process Type Export

External Column Name Default Value

Field Format

Field Length (in bytes) 10 Decimal Length 2 Display Decimal Decimal Char .

Integer Length 6 Round Decimal Standard Rounding Rules Blank If Zero

Sign Position Trailing Negative - Use Positive Sign

Justification Left Pad Character

Date Format Remove Trailing Spaces

Null Blank Character Flds Null Zero Numeric Flds

Step 2b: Set Up the Field Definition Table Component, PeopleSoft Table and Fields

Identify the corresponding PeopleSoft table and field for the DEDAMT field:

- Table: DED_CALC
- Field: DED_CUR

Note

You *must* set up the DED_CALC table and DED_CUR field in the PS Tables component before you can access them through the Field Definition component.

Use the Field Definition Table - Interface Field2 page to identify the PeopleSoft record (table) and fields:

Navigation:

Set Up HCM, and then **Product Related**, and then **Payroll Interface**, and then **Interface Controls**, and then **Field Definition Table**, and then **Interface Field2**

This example illustrates the fields and controls on the Interface Field2 page for Step 2b: Set Up the Field Definition Table Component, PeopleSoft Table and Fields.

Interface Field1 | **Interface Field2**

System ID LOG Logical File Sample Field ID DEDAMT

Field Definition Find | View All First 1 of 1 Last

Effective Date 01/01/1980 Description Deduction Amount

PS Record Name DED_CALC Process ID

PS Field1 Name DED_CUR PS Field2 Name

PS Field3 Name PI Translate Indicator No Translate Values

Instance ID

Translate Values Personalize | Find | View All First 1 of 1 Last

PS Value 1	PS Value 2	PS Value 3	PI Value

Step 3: (Optional) Set Up the Instance Table Component

Instance IDs enable you to restrict or modify the data that is sent to the third-party payroll system.

Deduction class values are A (after tax), B (before tax), N (non-taxable or employer paid), and T (taxable or imputed income). The Calculate Deductions process calculates deductions for all classes (A, B, N, T). In this example, the third-party payroll system wants to receive deductions only for class values A and B. Therefore, set up an instance ID DEDCLS for the DED_CLASS field to export calculated deductions for class values A and B. (Alternatively, you can set up the instanced ID to exclude class values N and T.)

Note

When setting up an instance ID, you can either *include* the values that you want to export or *exclude* values that you don't want to export. You may need to experiment to determine which set up works best. Alternatively, you can create a view to retrieve a restricted data set.

Use the Interface Instance Table page to set up instance IDs.

Navigation:

Set Up HCM, and then **Product Related**, and then **Payroll Interface**, and then **Interface Controls**, and then **Instance Table**, and then **Interface Instance Table**

This example illustrates the fields and controls on the Interface Instance Table page for Step 3: (Optional) Set Up the Instance Table Component.

Interface Instance Table

System ID LOG Logical File Sample
InstanceID DEDCLS

Definition Find | View All First 1 of 1 Last

Effective Date 01/01/1980 Description Include Deduction Types + -

Short Description Ded Types 'Instance Indicator Value v

PeopleSoft Record Name DED_CALC PeopleSoft Field1 Name DED_CLASS

Include Exclude Indicator Include Values v

Instance Information Personalize | Find | View All | 1-3 of 3 Last

*Sequence	Field1 Value		
1	A	+ -	
2	B	+ -	
3	T	+ -	

Step 4a: Set Up the Definition Table Component, File

Define the file, record, and field sequences for the export file.

Note

If you change any of the records or fields for a transaction, be sure to make the same changes to the records or fields for the corresponding stop transaction.

Use the Interface Definition File page to access the LOGEXP export file.

Navigation:

Set Up HCM, and then **Product Related**, and then **Payroll Interface**, and then **Interface Controls**, and then **Definition Table**, and then **Interface Definition File**

This example illustrates the fields and controls on the Interface Definition File page for Step 4a: Set Up the Definition Table Component, File.

The screenshot shows the 'Interface Definition File' page for File ID LOGEXP. The page has three tabs: 'Interface Definition File' (selected), 'Interface Definition Record', and 'Interface Definition Fields'. The main content area is titled 'File ID Definition' and contains the following fields and controls:

- Effective Date:** 01/01/1980
- Description:** Logical Export Sample
- System ID:** LOG (Logical)
- Process Type:** Export
- File Type:** Logical
- PI Record Length:** 80
- Data Delimiter:** (empty)
- Status:** Active
- Short Desc:** Logical
- Convert Case:**
- Include Header:**
- Max Fields Per Output Rec:** 5
- External Field ID Indicator:** Y

Step 4b: Set Up the Definition Table Component, Record

The LOGEXP export file includes nine record sequences. Record 40 is the deduction transaction. Record 50 is the deduction stop transactions.

Record Sequence	Record ID	Description
10	PERS	Personal Data
20	EMPL	Employment Data
30	JOB	Job Data
40	DED	Deductions
50	SDED	Stop Deductions
60	SAVE	Savings
70	SSAV	Stop Savings
80	APAY	Additional Pay
90	SPAY	Stop Additional Pay

Record 40, the deduction transaction (DED), includes:

- Record type: Data

- Instance ID: DEDCLS—the instance ID created in step 3.
- Process ID: 000001 ON1 Change—a process required for the deduction transaction.

Use the Interface Definition Record page to set up the record sequences for the export file.

Navigation:

Set Up HCM, and then **Product Related**, and then **Payroll Interface**, and then **Interface Controls**, and then **Definition Table**, and then **Interface Definition Record**

This example illustrates the fields and controls on the Interface Definition Record page for Step 4b: Set Up the Definition Table Component, Record.

The screenshot shows the Oracle Interface Definition Record page for File ID LOGEXP. The page has three tabs: "Interface Definition File", "Interface Definition Record", and "Interface Definition Fields". The "Interface Definition Record" tab is active. The page displays the following fields and controls:

- File ID:** LOGEXP
- File ID Definition:** Find | View All | First 1 of 1 | Last
- Effective Date:** 01/01/1980
- Status:** Active
- Description:** Logical Export Sample
- Short Desc:** Logical
- System ID:** LOG (Logical)
- Process Type:** Export
- File Type:** Logical
- Convert Case:**
- Include Header:**
- PI Record Length:** 80
- Max Fields Per Output Rec:** 5
- Data Delimiter:** |
- External Field ID Indicator:** Y

Step 4c: Set Up the Definition Table Component, Fields

Record 40, the deduction transaction, includes five field sequences:

- Field Seq#: 10–50.
- Field Seq 40 and 50 are a grouped field (Group ID 001).
- Field Seq 50 is DEDAMT, the actual deduction amount.

Note

The field sequences (10–50) for transaction record 40 must be identical to the field sequences for stop transaction record 50. The *value* of field sequence 50 changes from DEDAMT to ZAMT.

Use the Interface Definition Fields page to set up the field sequences for the record:

Navigation:

Set Up HCM, and then **Product Related**, and then **Payroll Interface**, and then **Interface Controls**, and then **Definition Table**, and then **Interface Definition Fields**

This example illustrates the fields and controls on the Interface Definition Fields page for Step 4c: Set Up the Definition Table Component, Fields.

Interface Definition Fields										
File ID		LOGEXP		Logical Export Sample		Effective Date		01/01/1980		
Definition		Rec Seq Nbr		40		Record ID		DED Deduction Data		
PS Record		DED_CALC								
Field Sequence	Redefine	Field ID	Description	Start Position	Field Length	Field1 Name	Convert Case	Reverse Sign	Key Field	Group ID
10	<input type="checkbox"/>	CMPKEY	Company Key	1	9	COMPANY	<input checked="" type="checkbox"/>	<input type="checkbox"/>	Record Lev	
20	<input type="checkbox"/>	EMPLID	EMPLID	10	6		<input checked="" type="checkbox"/>	<input type="checkbox"/>	Record Lev	
30	<input type="checkbox"/>	BLNK4	4 Blanks	16	4		<input checked="" type="checkbox"/>	<input type="checkbox"/>	Record Lev	
40	<input type="checkbox"/>	DEDCD	Deduction Code	20	10	DEDCD	<input checked="" type="checkbox"/>	<input type="checkbox"/>	Occurrence	001
50	<input type="checkbox"/>	DEDAMT	Deduction Amount	30	10	DED_CUR	<input type="checkbox"/>	<input type="checkbox"/>	Not a Key F	001

Setting Up a Stop Transaction

Follow these steps to set up a stop transaction for deductions using the LOGEXP export file.

Step 1: Set Up the Field Definition Table Component, Export File Fields

For Payroll Interface to recognize a stop transaction, the delivered record-level process IDs must be used. PeopleSoft code moves the pay period end date (of the pay calendar entry being used with the run control) to the DATE_VAL field in the PI_PARTIC_EXTBL table when a stop process is identified. Along with the date, you'll see the corresponding field ID and CHAR_VAL (for example, for a deduction code).

See [Export Processing](#).

Define the field for the deduction stop transaction: ZAMT. When the stop transaction is processed, the ZAMT default value, rather than the DEDAMT default value, is written to the export file.

The default value is determined by the requirements of the third-party payroll system (refer to the vendor documentation). For LOG systems, the default value may be 000.00 or zero. For CSV systems, the default value may be probably ~, the tilde character.

Use the Interface Field1 page to set up a field definition for the ZAMT field:

Navigation:

Set Up HCM, and then **Product Related**, and then **Payroll Interface**, and then **Interface Controls**, and then **Field Definition Table**, and then **Interface Field1**

This example illustrates the fields and controls on the Interface Field1 page for Step 1: Set Up the Field Definition Table Component, Export File Fields.

Interface Field1 | Interface_Ejeld2

System ID CSV CSV Sample Layout Field ID D001

Field Definition Find | View All First 1 of 1 Last

*Effective Date 01/01/1980 *Status Active

Description Deduction Code Short Desc Ded Cd

External Field ID D001 Process Type Export

*Type Character Text

External Column Name Deduction Code Default Value ZZ

Field Format

*Field Length (in bytes) 8 Decimal Length Display Decimal

Integer Length Round Decimal Blank If Zero

Sign Position Negative Use Positive Sign

Justification Left Pad Character

Date Format Remove Trailing Spaces

Null Blank Character Flds Null Zero Numeric Flds

Note

Because the ZAMT field does not correspond to a PeopleSoft table or field, the Interface Field2 page does not need to be set up.

Step 2: Review the Process Table

Identify the COBOL process that will perform the stop transaction. This can be one of the processes delivered with Payroll Interface or a user-defined process. In this example, use Payroll Interface Process ID 000026.

See [Working with COBOL Processes](#).

After the process is attached to the stop transaction record (see step 3), it runs in the background during the Export process. If the process determines that a deduction code is missing, the ZAMT default value (rather than the DEDAMT default value) is written to the export file and a flag on the PI_PARTIC_EXPT table is set to P.

See [Export Processing](#).

Use the Interface Process Table page to view the processes that are delivered with Payroll Interface.

Navigation:

Set Up HCM, and then **Product Related**, and then **Payroll Interface**, and then **Interface Controls**, and then **Process Table**, and then **Interface Process Table**

This example illustrates the fields and controls on the Interface Process Table page for Step 2: Review the Process Table.

Interface Process Table

Process Details Find | View All First 1 of 1 Last

Process ID 000001 + -

*PI Process Phase Record Processing Short Description Ded End Dt

*Type Record + -

User Defined Process

Process Description Deduction End Date. When the primary PeopleSoft source for the transaction is Additional Earnings, the earnings end date is matched against the Pay End Date to determine if the Additional Earnings should be stopped.

Returned Values Personalize | Find | View All | First 1 of 1 Last

Returned Value	Description

Step 3a: Set Up the Definition Table Component, File

Define the file, record, and field sequences for the export file.

Use the Interface Definition File page to access the LOGEXP export file.

Navigation:

Set Up HCM, and then **Product Related**, and then **Payroll Interface**, and then **Interface Controls**, and then **Definition Table**, and then **Interface Definition File**

This example illustrates the fields and controls on the Interface Definition File page for Step 3a: Set Up the Definition Table Component, File.

Interface Definition File | Interface Definition Record | Interface Definition Fields

File ID LOGEXP

File ID Definition Find | View All First 1 of 1 Last

*Effective Date 01/01/1980 *Status Active + -

Description Logical Export Sample Short Desc Logical

System ID LOG Logical

Process Type Export

File Type Logical Convert Case Include Header

PI Record Length 80 Max Fields Per Output Rec 5

Data Delimiter External Field ID Indicator Y

Step 3b: Set Up the Definition Table Component, Record

Record 50, the deduction stop transaction (SDED), includes:

- Record Type: Process
- Base Rec: 40—the corresponding record for the deduction transaction.

- Process ID: 000026—the process that stops the deduction.

Note

The Base Rec field joins the transaction to the stop transaction: record 40 is joined to record 50.

Use the Interface Definition Record page to set up the record sequences for the export file.

Navigation:

Set Up HCM, and then **Product Related**, and then **Payroll Interface**, and then **Interface Controls**, and then **Definition Table**, and then **Interface Definition Record**

This example illustrates the fields and controls on the Interface Definition Record page for Step 3b: Set Up the Definition Table Component, Record.

The screenshot displays the 'Interface Definition Record' page. At the top, there are tabs for 'Interface Definition File', 'Interface Definition Record', and 'Interface Definition Fields'. The main window shows a record definition for 'LOGEXP Logical Export Sample' with an effective date of 01/01/1980. The record sequence number is 40, the record ID is DED, and the record type is Data. The description is 'Deduction Data'. The PS Record is DED_CALC, and the Base Rec field is empty. The Occur Ind is set to 'Multi Recs to Multi Defn Recs'. The Instance ID is DEDCLS, and the Ded Types field is empty. The Process ID is 000001, and the Record Terminated Length is 1. The Record Terminated Value field is empty.

Step 3c: Set Up the Definition Table Component, Fields

Record 50, the deduction stop transaction, includes five field sequences:

- Field Seq#: 10–50.
- Field Seq 40 and 50 are a grouped field (Group ID 001).
- Field Seq 50 is now ZAMT, the zero amount that is sent when the deduction is stopped.

Note

The field sequences (10–50) for stop transaction record 50 must be identical to the field sequences for transaction record 40. The *value* of field sequence 50 changes from DEDAMT to ZAMT.

Use the Interface Definition Fields page to set up the field sequences for the record:

Navigation:

Set Up HCM, and then Product Related, and then Payroll Interface, and then Interface Controls, and then Definition Table, and then Interface Definition Fields

This example illustrates the fields and controls on the Interface Definition Fields page for Step 3c: Set Up the Definition Table Component, Fields.

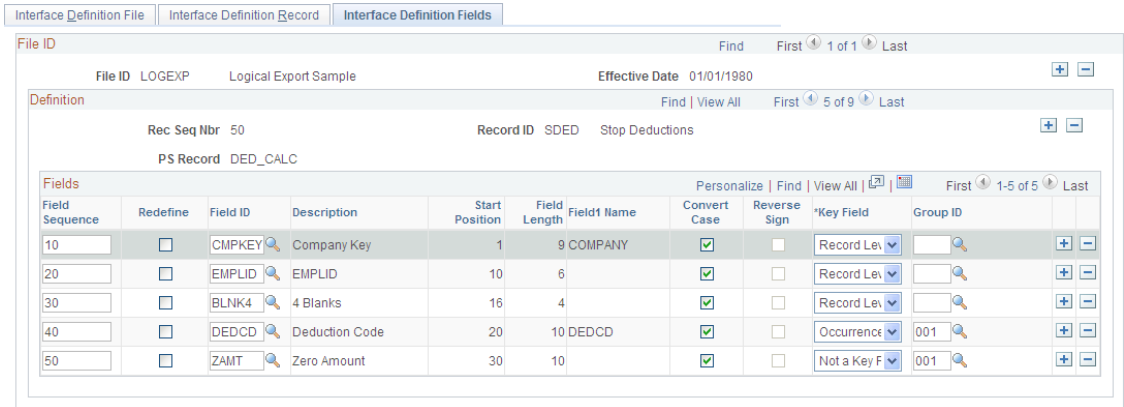

Verifying a Transaction

To verify the transaction:

1. Run the Calculate Deductions and Confirmation processes.
2. Run the Export process.

Step 1: Run the Calculate Deductions and Confirmation Processes

Calculate and confirm the deductions for the employee.

Use the Calculate Deductions page to calculate the deductions:

Navigation:

Payroll Interface, and then **Pay Period Deductions**, and then **Calculate Deductions**, and then **Calculate Deductions**

This example illustrates the fields and controls on the Calculate Deductions page for Step 1: Run the Calculate Deductions and Confirmation Processes.

Calculate Deductions

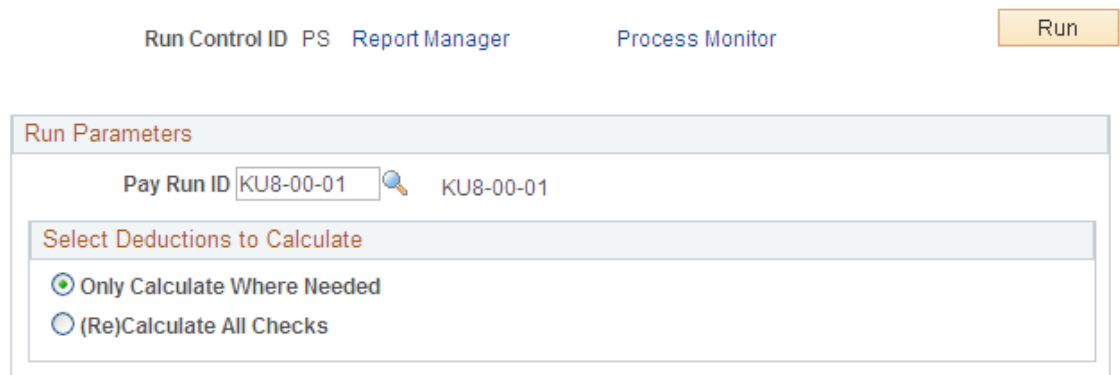

Review the results. The employee has medical and dental before-tax and nontaxable deductions. However, because the DEDCLS instance ID is set up, only the before-tax deductions will appear in the export file.

Use the Review Deductions page to review deductions.

Navigation:

Payroll Interface, and then **Pay Period Deductions**, and then **Review Deductions**, and then **Review Deductions**

This example illustrates the fields and controls on the Review Deductions page for Step 1: Run the Calculate Deductions and Confirmation Processes.

Review Deductions

Deduction Details							
Employee ID KUI011				Company GBI			
Empl Record 0				Pay Group KU8			
Name William Fraas				Pay End Date 01/02/2000			
Deductions							
Personalize Find View All First 1-4 of 4 Last							
Plan Type	Benefit Plan	Deduction Class	Deduction Code	Description	Current Deduction	Coverage Base	Current Deduction Payback
Medical	KUHMO1	Before-Tax	KUHMOK	Kaiser HMO	59.77		
Medical	KUHMO1	Nontaxable	KUHMOK	Kaiser HMO	60.00		
Dental	KUDEN2	Before-Tax	KUDEN9	Dental Plan	7.79		
Dental	KUDEN2	Nontaxable	KUDEN9	Dental Plan	1.85		

Step 2: Run the Export Process

Use the Import/Export Payroll Data page to run the Export process:

Navigation:

Payroll Interface, and then **Payroll Data Exchanges**, and then **Import/Export Payroll Data**, and then **Import/Export Payroll Data**

This example illustrates the fields and controls on the Import/Export Payroll Data page for Step 2: Run the Export Process.

Import/Export Payroll Data

Run Control ID PS Report Manager Process Monitor Run

Run Parameters

*Pay Run ID Run Type

*PI Run Option *PI Run Number

Check Point Interval

Export Options

*Select Type Run Select and Compare Only

*Export Change or Full Exclude Calculated Deductions

Active Employees

Reprocess

Compare Export

Review the export file. Because the instance ID DEDCLS is set up, only the before-tax deductions appear in the export file. Notice, however, that the transaction has worked. The DEDAMT or 59.77 value appears in the export file for deduction code KUHMOK:

This example illustrates the fields and controls on the Export file showing the transaction for deduction KUHMOK is the amount of 59.77.

GBI	KUI011	ID	KUI011		
GBI	KUI011	LAST	FRAAS		
GBI	KUI011	FIRST	WILLIAM		
GBI	KUI011	ADDRESS	310 DONTELL ST.		
GBI	KUI011	ADDRESS2			
GBI	KUI011	CITY	KERNVILLE		
GBI	KUI011	STATE	CA		
GBI	KUI011	ZIP	932238		
GBI	KUI011	PHONE	9256947911		
GBI	KUI011	SSNUM	550555001		
GBI	KUI011	HIREDATE	03/15/1990		
GBI	KUI011	REHIREDT			
GBI	KUI011	SERVDT	03/15/1990		
GBI	KUI011	BIRTHDATE	01/08/1951		
GBI	KUI011	LAST_DAY			
GBI	KUI011	TERMDATE			
GBI	KUI011	ORIGHIRE	03/15/1990		
GBI	KUI011	SEX	M		
GBI	KUI011	TITLE			
GBI	KUI011	HDEPT	63000		
GBI	KUI011	JOBTITLE	820050		
GBI	KUI011	HCCODE	820050		
GBI	KUI011	EMPTYTYPE	S		
GBI	KUI011	STATUS	A		
GBI	KUI011	ST_CLASS	RFT		
GBI	KUI011	CYCLE	W		
GBI	KUI011	SAL_HR	S		
GBI	KUI011	STDHRS	000040.00		
GBI	KUI011	RATE1	000000080000.0000		
GBI	KUI011	LASTRAISE			
GBI	KUI011	SHIFT1	N		
GBI	KUI011	PAYBYEX	Y		
GBI	KUI011	OTEXEMPT	Y		
GBI	KUI011	FLSA	E		
GBI	KUI011	SUPERNAME			
GBI	KUI011	PAYGROUP	KU8		
GBI	KUI011	DEDUCTION	KUHMOK	AMOUNT	000059.77
GBI	KUI011	DEDUCTION	KUDEN9	AMOUNT	000007.79

Verifying a Stop Transaction

To verify the stop transaction:

1. Terminate one of the benefits for the employee.
2. Run the Calculate Deductions and Deduction Confirmation processes.
3. Run the Export process.

Step 1: Terminate a Benefit

Terminate the medical benefits for the employee, deduction code KUHMOK.

Use the Health Benefits page to terminate the medical benefits.

Navigation:

Workforce Administration, and then **Benefit Information NLD**, and then **Enroll in Benefits**, and then **Health Benefits**, and then **Health Benefits**

This example illustrates the fields and controls on the Health Benefits page for Step 1: Terminate a Benefit.

Health Benefits

William Fraas Employee ID KUI011 Benefit Record Number 0

Plan Type 10 Medical

*Coverage Begin Date 03/15/1990 *Deduction Begin Date 03/15/1990

Coverage Election: Elect Waive Terminate *Election Date 03/15/1990

Benefit Program GBI US Pgm
Benefit Plan KUHMO1 Medical HMO Plan 1 Option Code A4
Coverage Code 4 Family
Health Provider ID Previously Seen
Employee Status Active

ID	Name	Relationship to Employee	Health Provider ID	Prev Seen	Covered Person Type	Age Limit Flg
01	Fraas, Jennifer	Spouse	<input type="text"/>	<input type="checkbox"/>	Spouse	N
02	Fraas, Jeffrey	Child	<input type="text"/>	<input type="checkbox"/>	Child	Y

Step 2: Run the Calculate Deductions and Confirmation Processes

Calculate and confirm the deductions for the employee. The terminated medical benefits no longer appear.

Use the Review Deductions page to review the deductions.

Navigation:

Payroll Interface, and then **Pay Period Deductions**, and then **Review Deductions**, and then **Review Deductions**

This example illustrates the fields and controls on the Review Deductions page for Step 2: Run the Calculate Deductions and Confirmation Processes.

Review Deductions

Plan Type	Benefit Plan	Deduction Class	Deduction Code	Description	Current Deduction	Coverage Base	Current Deduction Payback
Medical	KUHMO1	Before-Tax	KUHMOK	Kaiser HMO	59.77		
Medical	KUHMO1	Nontaxable	KUHMOK	Kaiser HMO	60.00		
Dental	KUDEN2	Before-Tax	KUDEN9	Dental Plan	7.79		
Dental	KUDEN2	Nontaxable	KUDEN9	Dental Plan	1.85		

Step 3: Run the Export Process

Run the Export process and review the export file. Notice that the stop transaction succeeded. The ZAMT or 000.00 value appears in the export file for deduction code KUHMOK, the terminated medical benefit.

This example illustrates the export file showing the stop transaction for deduction KUHMOK is the amount of 00.00.

```

GBI      KUI011      ID          KUI011
GBI      KUI011      LAST        FRAAS
GBI      KUI011      FIRST      WILLIAM
GBI      KUI011      ADDRESS    310 DONTELL ST.
GBI      KUI011      ADDRESS2
GBI      KUI011      CITY       KERNVILLE
GBI      KUI011      STATE      CA
GBI      KUI011      ZIP        932238
GBI      KUI011      PHONE      9256947911
GBI      KUI011      SSNUM      550555001
GBI      KUI011      HIREDATE   03/15/1990
GBI      KUI011      REHIREDT
GBI      KUI011      SERVDT     03/15/1990
GBI      KUI011      BIRTHDATE  01/08/1951
GBI      KUI011      LAST_DAY
GBI      KUI011      TERMDATE
GBI      KUI011      ORIGHIRE   03/15/1990
GBI      KUI011      SEX        M
GBI      KUI011      TITLE
GBI      KUI011      HDEPT      63000
GBI      KUI011      JOBTITLE   820050
GBI      KUI011      HCCODE     820050
GBI      KUI011      EMPTYPE    S
GBI      KUI011      STATUS     A
GBI      KUI011      ST_CLASS   RFT
GBI      KUI011      CYCLE      W
GBI      KUI011      SAL_HR     S
GBI      KUI011      STDHRS     000040.00
GBI      KUI011      RATE1      000000080000.0000
GBI      KUI011      LASTRAISE
GBI      KUI011      SHIFT1     N
GBI      KUI011      PAYBYEX    Y
GBI      KUI011      OTEXEMPT   Y
GBI      KUI011      FLSA       E
GBI      KUI011      SUPERNAME
GBI      KUI011      PAYGROUP   KUS
GBI      KUI011      DEDUCTION  KUDEN9      AMOUNT      000007.79
GBI      KUI011      DEDUCTION  KUHMOK      AMOUNT      000000.00

```

11

Maintaining Payroll Data

Understanding Payroll Data

After the interface definitions are set up and payroll processing has commenced, Payroll Interface enables you to maintain certain payroll data, including additional pay, general deductions, employee tax withholding information, direct deposits, and information for employees with multiple jobs.

Maintenance tasks include the initial setup of the component pages followed by the additions, changes, or deletions that normally occur to payroll-related data over time. Because most of the payroll data works in conjunction with other information that you are required to set up for Payroll Interface, the maintenance tasks are discussed in this topic as well as other related setup topics in this product documentation.

Note

Depending on the requirements of the third-party payroll system, you may not need to maintain all of the data that is discussed in this topic. Or if the data *is* required, to simplify data entry, conversion, and maintenance issues, it may be easier to have the third-party payroll system manage the data.

This diagram illustrates the types of payroll data that you may need to maintain:

This diagram illustrates the types of payroll data that you may need to maintain.

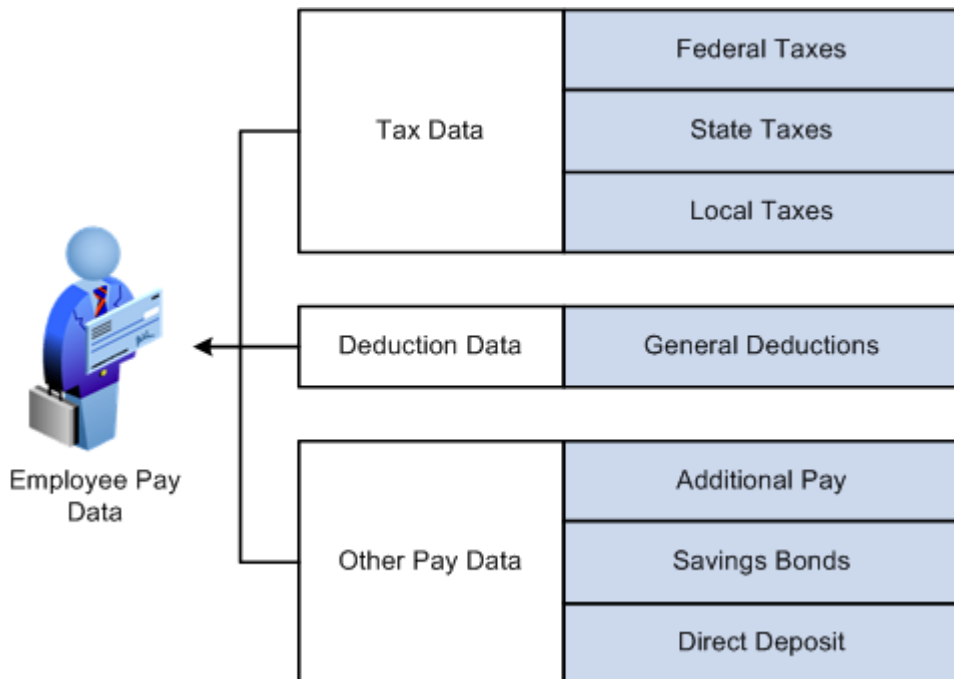

Maintaining Additional Pay

To maintain additional pay, use the Additional Pay (ADDITIONAL_PAY) component.

Related Topics

- [Setting Up and Maintaining Additional Pay](#)
To set up and maintain additional pay, use the Additional Pay (ADDITIONAL_PAY) component.

Maintaining General Deductions

To maintain general deductions, use the General Deduction (GENL_DED_DATA) and Override General Deductions (GENL_DED_OVERRIDE) components.

Related Topics

- [Setting Up and Maintaining General Deductions](#)
To set up and maintain general deductions, use the Deduction Table (DEDUCTION_TABLE) and General Deduction Table (GENL_DEDUCTION_TBL) components.

Maintaining Tax Distribution Data

To maintain tax distribution data, use the Tax Distribution Data USA (TAX_DISTRIBUTION) and Tax Distribution Data CAN (TAX_DISTRIBUTION) components.

Related Topics

- [\(CAN\) \(USA\) Setting Up and Maintaining Tax Distribution Data](#)
Use the Update Tax Distribution component in Payroll for North America to set up and maintain USA and CAN tax distribution data.

Maintaining Employee Tax Data

To maintain employee tax data, use the Employee Tax Data USA (TAX_DATA) and Employee Tax Data CAN (TAX_DATA_CAN) components.

Related Topics

- [\(USA\) Setting Up and Maintaining U.S. Employee Tax Data](#)
Use the Employee Tax Data USA component to maintain USA employee tax data.
- [\(CAN\) Setting Up and Maintaining Canadian Employee Tax Data](#)
Use the Update Employee Tax Data component in Payroll for North America to set up and maintain CAN employee tax data.

(CAN) (USA) Setting Up and Maintaining Direct Deposit

For information on setting up direct deposits of employee pay, see:

- *Payroll for North America*, PeopleSoft Payroll for North America: Setting Up Banks and Direct Deposit
- *Payroll for North America*, PeopleSoft Payroll for North America: Setting Up Direct Deposits

Setting Up and Maintaining Optional Payroll Data

To set up and maintain optional payroll data, use the Payroll Options (PAYROLL_DATA) component.

Pages Used to Set Up and Maintain Optional Payroll Data

Page Name	Definition Name	Usage
Payroll Options 1 Page	PAYROLL_DATA1	Set up paycheck delivery and distribution options.
Payroll Options 2 Page	PAYROLL_DATA2	Set up paycheck location and payroll deduction subset options.

Understanding Optional Payroll Data

Optional payroll processing information, such as check distribution and deduction subset options, is often necessary when employees have multiple jobs or have multiple jobs and need to be paid through more than one payroll system.

If you are setting up multiple jobs:

- Calculate Deductions — Follow guidelines in your *PeopleSoft Benefits Administration* product documentation.
- Benefit Deductions — Follow guidelines in your *PeopleSoft Benefits Administration* product documentation.
- General Deductions — Set up and maintain the Payroll Options component, Payroll Options 2 page.

See [Payroll Options 2 Page](#).

Payroll Options 1 Page

Use the Payroll Options 1 page (PAYROLL_DATA1) to set up paycheck delivery and distribution options.

Navigation:

Payroll Interface, and then **Update Payroll Information**, and then **Payroll Options**, and then **Payroll Options 1**

This example illustrates the fields and controls on the Payroll Options 1 page.

Payroll Options 1

Payroll Options 2

Charles Koberg ID KUI006 Company GBI

Paycheck Delivery Option

Company Distribution
 Postal Service

Distribution Mail Option

Home Address
 Mailing Address
 Check Address
 [Update Check Address](#)

Employee's Current Address

Country USA United States
Address 874 Westheimer Rd.
 Houston, TX 77063

Paycheck Delivery Option

Field or Control	Description
Company Distribution	Select to indicate that the check should be handed out as part of a regular company distribution.
Postal Service	Select to indicate that the check should be mailed using the Postal Service.

Distribution Mail Option

Use the options in the Distribution Mail Option group box to indicate how an employee's check should be distributed.

Field or Control	Description
Home Address	Select to send checks to the employee's home address. The system automatically displays the home address from the employee's personal data in PeopleSoft HCM.
Mailing Address	Select to send checks to the employee's mailing address. The system automatically displays the mailing address from the employee's personal data in PeopleSoft HCM.
Check Address	Select to send checks to the employee's check address. The system automatically displays the check address from the employee's personal data in PeopleSoft HCM.
Update Check Address	Select to update the employee's check address here, rather than on the Personal Data component.

Payroll Options 2 Page

Use the Payroll Options 2 page (PAYROLL_DATA2) to set up paycheck location and payroll deduction subset options.

Navigation:

Payroll Interface, and then **Update Payroll Information**, and then **Payroll Options**, and then **Payroll Options 2**

This example illustrates the fields and controls on the Payroll Options 2 page.

The screenshot shows the 'Payroll Options 2' page for employee Charles Koberg (ID KUJ006, Company GBI). The 'Primary PayGroup' is set to KU7 and 'Deduction Calc Record' is 0. The 'Paycheck Location Option' section has three radio buttons: 'Home Department Location' (selected), 'Job Location', and 'Other Location'. Below this is the 'Other Location Information' section with 'Set ID' and 'Location Code' fields. Further down are 'Mail Drop ID' and 'Paycheck Name' fields. The 'Deductions Taken' section shows a dropdown menu set to 'No Override' and a 'Deduction Subset ID' field.

Field or Control	Description
Primary PayGroup	Select to identify the pay group for which a consolidated paysheet will be created when an employee is being paid in different pay groups during the same pay run. The primary pay group also controls whether deductions or additional pay should be taken for the pay period. For employees with multiple jobs, PeopleSoft recommends that you select, as the primary pay group, the one in which the employee is paid most often. If you leave this field blank, the system uses the default pay group that is associated with the first job into which the employee was hired. Note: You are responsible for verifying that this value is correct for each employee.

Paycheck Location Option

Use the options in the Paycheck Location Option group box to specify which location code to use as a sort option for printing paychecks for this pay group. These options are used only if:

- The **Company Distribution Order** option is selected as the paycheck sequence option on the Pay Group Table - Check Distribution page.

- The **Select on Payroll Data Panel** option is selected as the paycheck location option on the Pay Group Table - Check Distribution page.
- The location is entered as a check print sequence on the Pay Group Table - Check Sequencing page.

See PeopleSoft Payroll Interface: Understanding Payroll Schedules.

Note

You must create location codes in the Location table before you can use them here or elsewhere in the system.

Field or Control	Description
Home Department Location	Select the location code (in the Department table) that is associated with the department ID on the employee's Job record that is used as a sort option for printing checks.
Job Location	Select the location on the employee's Job record that is used as a sort option for printing checks.
Other Location	Select to enter a different location code to use as a sort option for printing checks. In this case, the system uses the designated agent address and transmits the check for office delivery. If you select the Other Location option, you also must select a setID and a location code.
SetID	Select the setID for the location code.
Location CD (location code)	Select a location code to indicate this location as a sort option for printing checks. Use this option only if the <i>Select on Payroll Data Panel</i> option is selected as the paycheck location option on the Pay Group Table - Check Distribution page.
Mail Drop ID	Select to enter the employee's mail drop ID.
Paycheck Name	Select to enter a name, other than the employee name that is entered on the Personal Data record, to whom the paycheck should be made out. This field is not formatted, so enter the name exactly as you want it to appear on the paycheck.

Deductions Taken

Use the options in the Deductions Taken group box to indicate how to take deductions for an employee. Selections made on this page override the values that are entered for the pay run in the **General Deductions Taken** field on the Pay Calendar table. Values include:

Field or Control	Description
Deductions Taken	<ul style="list-style-type: none"> <i>NoOverride</i>: This is the default value. If this is unchanged, the deductions that are specified on the Pay Calendar table are not overridden on the paysheet at this stage in deduction override evaluation processing. <i>Deduction</i>: Select this value to process the standard general deductions for this employee as set up on the Deduction table. <i>None</i>: Select this value if no general deductions should be taken out of the paycheck. <i>Subset</i>: Select this value to take only those general deductions that are included in the deduction subset that you specify in the Deduction Subset ID field.
Deduction Subset ID	You must specify the subset ID if you select <i>Subset</i> in the Deductions Taken field.

(CAN) Setting Up and Maintaining Source Deductions

To set up and maintain source deductions, use the Update Source Deductions CAN (RUN_TAX103CN) component.

Page Used to Set Up and Maintain Source Deductions

Page Name	Definition Name	Usage
Update Source Deductions Page	RUN_TAX103CN	Run the Update Source Deductions SQR Report process (TAX103CN).

Understanding Source Deduction Processing

Use the Update Source Deductions SQR Report process (TAX103CN) to calculate and update federal, Quebec, and provincial basic source deductions for employees by generating a new Canadian Income Tax Data record for each employee who is active as of the effective date specified.

Set up and run this process at predefined intervals in preparation for the new year's payroll processing. The corresponding report (TAX103CN) provides a list of all records created.

Update Source Deductions Page

Use the Update Source Deductions page (RUN_TAX103CN) to run the Update Source Deductions SQR Report process (TAX103CN).

Navigation:

Payroll Interface, and then **Update Payroll Information**, and then **Update Source Deductions CAN**, and then **Update Source Deductions**

This example illustrates the fields and controls on the Update Source Deductions page (1 of 2).

Update Source Deductions

Run Control ID ES Report Manager Process Monitor

Language English ▼

Report Request Parameter(s)

Effective Date

Reset Options

Reset Special Letters	<input type="text" value="Y"/>	Reset Special Letters (Quebec)	<input type="text" value="Y"/>
Reset Federal Commission	<input type="text" value="Y"/>	Reset Quebec Commission	<input type="text" value="Y"/>
Reset CPP Subject Months	<input type="text" value="N"/>	Reset Quebec Health	<input type="text" value="Y"/>
Reset Cross Province	<input type="text" value="Y"/>		

This example illustrates the fields and controls on the Update Source Deductions page (2 of 2).

Basic Claim Amounts

Override Or Increase Federal By

Override Amount

Percent

Amount

Quebec Increase By

Percent

Amount

Provincial Increase By 🔍 | ⏪ ⏩ 1 of 1 ▼ ⏭ ⏮

*Province 🔍 + -

Percent Amount

Percentage changes will be applied before fixed amount changes.

Field or Control	Description
Reset Special Letters	Enter Y (yes) to reset the special letters amount to zero.
Reset Federal Commission	Enter Y to reset the federal commission amounts to zero.

Field or Control	Description
Reset CPP Subject Months (reset Canada Pension Plan subject months)	<p>Y (yes): Reset the employee's CPP subject months to 12.</p> <p>N (no): Reset the employee's CPP subject months to zero when the employee's original CPP subject months are fewer than 12 (for example, to reset CPP subject months to zero for employees who no longer contribute to CPP). If the employee's original CPP subject months are 12, they remain 12.</p>
Reset Cross Province	<p>Y (yes): The Cross Province check box on the Canadian Income Tax Data 2 page is deselected when the new record is created.</p> <p>N (no): The Reset Cross Province check box and associated field values are copied to the newly created record.</p>
Reset Special Letters (Quebec)	Enter Y (yes) to reset the Quebec special letters amount to zero.
Reset Quebec Commission	Enter Y (yes) to reset the Quebec commission amounts to zero.
Reset Quebec Health	Enter Y (yes) to deselect the Exempt from Quebec Health check box on the Quebec Income Tax Data page for all employees for whom Exempt from Quebec Health is currently selected. Resetting in this way makes no employee exempt from Quebec Health.
Field or Control	Description
Override Or Increase Federal By	<p>Use this group box to perform updates to employees' federal basic claim amounts.</p> <p>Use percent, amount, or both to specify the value of the increase when the Override Amount check box is not selected.</p> <p>Use amount to specify the override amount when the Override Amount check box is selected. The amount will default to the Federal Basic Personal Amount from the Canadian Tax Table if amount is zero or blank.</p>
Quebec Increase By	Use this group box to perform updates to employees' Quebec basic claim amounts. Use either percent or amount to specify the value of the increase.
Provincial Increase By	Use this group box to perform updates to employees' provincial basic personal amounts. Add rows to enter multiple provinces. Use either percent or amount to specify the value of the increase.

12

Running Deductions

Understanding Deduction Processing

If you maintain deduction information using Payroll Interface and the Manage Base Benefits business process in PeopleSoft HR, then you must run the Calculate Deductions and Confirm Deductions processes before running the Export process.

The deduction processes use the information that you set up through the Manage Base Benefit business process to calculate and confirm *per pay period* deduction amounts. When the Export process is run, these amounts are exported, along with the other payroll data, to the third-party payroll system. The third-party payroll system performs the gross to net calculations.

Note

If you do not maintain deductions (that is, if the third-party payroll system manages all deduction information), then you do not need to run the Calculate Deductions or Confirm Deductions processes.

See [Understanding Data Exchanges](#).

See *PeopleTools: Process Scheduler*

Calculating Deductions

Use the Calculate Deductions COBOL SQL process (PSPDCRUN) to calculate pay period deduction amounts. If an error occurs, correct the problem and then run the process again. You can run the Calculate Deductions process as many times as necessary to correct errors. After you have resolved all of the errors, you can run the Confirm Deductions process.

Note

To determine whether errors occurred during the Calculate Deductions process, examine *both* the deduction run (Review Deductions component) and the deduction messages (Review Error Messages component). You cannot run the Confirm Deductions process until all deduction calculation errors have been resolved.

To calculate deductions:

1. Run the Calculate Deductions process to calculate deductions.
See [Calculating Deductions](#).
2. Review the results of the deduction calculation run.
See [Reviewing Deductions](#).

Confirming Deductions

Use the Confirm Deductions COBOL SQL process (PSPDCCNF) to signify that the pay period deduction amounts have been calculated and are error free; that is, you have run the Calculate Deductions process, checked the results, rerun the process if necessary, and verified that the results are accurate. When you run the Confirm Deductions process, the system stores the results in the DED_CALC and DED_MESSAGE tables, and flags the pay calendar as confirmed (F flag). The deductions are now ready for the Export process.

Note

Again, to determine whether errors occurred during the Confirm Deductions process, examine *both* the deduction run (Review Deductions component) and the deduction messages (Review Error Messages component).

To confirm deductions:

1. Run the Confirm Deductions process to confirm the calculated deductions.
See [Confirming or Unconfirming Deductions](#).
2. Review the results of the deductions confirmation run.
See [Reviewing Deductions](#).

Reprocessing Deductions

Use the Deductions Unconfirm COBOL SQL process (PSPDCUNC) to unconfirm and reprocess deductions that have already been calculated and confirmed.

To process deductions, you run (and review) the Calculate Deductions and Confirm Deductions processes. After the Confirm Deductions process is run, no further changes can be made to deduction data for the pay period unless you reprocess the deductions.

To reprocess deductions:

1. Update or make the necessary changes to the deduction data.
2. Run the Deductions Unconfirm process to unconfirm the calculated deductions.
See [Confirming or Unconfirming Deductions](#).
3. Run the Calculate Deductions process to recalculate deductions.
4. Run the Confirm Deductions process to reconfirm the calculated deductions.

Calculating Deductions

To calculate deductions, use the Calculate Deductions (RUNCTL_DED_CALC) component.

Pages Used to Calculate Deductions

Page Name	Definition Name	Usage
Calculate Deductions Page	RUNCTL_DED_CALC	Select the deduction calculation options and run the Calculate Deductions COBOL SQL process (PSPDCRUN) to calculate deductions.

Calculate Deductions Page

Use the Calculate Deductions page (RUNCTL_DED_CALC) to select the deduction calculation options and run the Calculate Deductions COBOL SQL process (PSPDCRUN) to calculate deductions.

Navigation:

Payroll Interface, and then **Pay Period Deductions**, and then **Calculate Deductions**, and then **Calculate Deductions**

This example illustrates the fields and controls on the Calculate Deductions page.

Calculate Deductions

[Run Control ID](#) [PS](#) [Report Manager](#) [Process Monitor](#) Run

Run Parameters

Pay Run ID US KU1 Weekly Pay 01Jan 04

Select Deductions to Calculate

Only Calculate Where Needed
 (Re)Calculate All Checks

Field or Control	Description
Pay Run ID	Select a pay run ID. The pay run ID identifies the pay groups to be processed. See Understanding Payroll Schedules .

Field or Control	Description
Select Deductions to Calculate	<p>Select:</p> <ul style="list-style-type: none"> • Only Calculate Where Needed when employee-level changes occur. The system calculates deductions for employees who: <ul style="list-style-type: none"> – Were not yet calculated this pay period. – Were calculated, but errors occurred during the calculation process. – Had benefit or job changes since the last deduction calculation for the pay period. • (Re)Calculate All Checks when benefit-table-level changes occur that will affect deduction calculation, such as benefit premium adjustments. <p>Note: This option processes both benefit-table-level changes and employee-level changes.</p>

Confirming or Unconfirming Deductions

To confirm or unconfirm deductions, use the Confirm Deductions (RUNCTL_DED_CONF) component.

Pages Used to Confirm or Unconfirm Deductions

Page Name	Definition Name	Usage
Confirm Deductions Page	RUNCTL_DED_CONF	<p>Enter parameters to run the Confirm Deductions COBOL SQL process (PSPDCCNF) to confirm the calculated deductions.</p> <p>Enter parameters to run the Deductions Unconfirm COBOL SQL process (PSPDCUNC) to unconfirm the calculated deductions</p>

Confirm Deductions Page

Use the Confirm Deductions page (RUNCTL_DED_CONF) to enter parameters to run Confirm Deductions COBOL SQL process (PSPDCCNF) to confirm the calculated deductions.

Also use the page to enter parameters to run the Deductions Unconfirm COBOL SQL process (PSPDCUNC) to unconfirm the calculated deductions.

Navigation:

Payroll Interface, and then **Pay Period Deductions**, and then **Confirm Deductions**, and then **Confirm Deductions**

This example illustrates the fields and controls on the Confirm Deductions page.

Confirm Deductions

Run Control ID PS Report Manager Process Monitor

Run

Run Parameters

Pay Run ID US KU1 Weekly Pay 01 Jan 04

Field or Control	Description
Pay Run ID	Select the pay run ID of the deduction calculation run that you want to confirm or unconfirm. See Calculate Deductions Page .

Reviewing Deductions

To review deductions, use the Review Error Messages (DED_MESSAGE) and Review Deductions (DED_CALCULATIONS) components.

Pages Used to Review Deductions

Page Name	Definition Name	Usage
Error Messages Page	DED_MESSAGE	Review error messages after running a deduction process.
Review Deductions Page	DED_CALCULATIONS	Review deduction amounts after running a deduction process.

Review Deductions Page

Use the Review Deductions page (DED_CALCULATIONS) to review deduction amounts after running a deduction process.

Navigation:

Payroll Interface, and then **Pay Period Deductions**, and then **Review Deductions**, and then **Review Deductions**

This example illustrates the fields and controls on the Review Deductions page.

Review Deductions

Deduction Details							
Employee ID	KUI011			Company	GBI		
Empl Record	0			Pay Group	KU8		
Name	William Fraas			Pay End Date	01/02/2000		
Deductions							
				Personalize	Find	View All	First 1-4 of 4 Last
Plan Type	Benefit Plan	Deduction Class	Deduction Code	Description	Current Deduction	Coverage Base	Current Deduction Payback
Medical	KUHMO1	Before-Tax	KUHMOK	Kaiser HMO	59.77		
Medical	KUHMO1	Nontaxable	KUHMOK	Kaiser HMO	60.00		
Dental	KUDEN2	Before-Tax	KUDEN9	Dental Plan	7.79		
Dental	KUDEN2	Nontaxable	KUDEN9	Dental Plan	1.85		

Review Deductions

To access the Review Deductions page, you must first make selections on the Review Deductions search page. The Payline Calculation Status field has several options.

Field or Control	Description
Payline Calculation Status	<p>Always select and review the information for the <i>Calculation Error</i>, <i>Pay in Progress</i>, and <i>Updated by User</i> options.</p> <p>Note: Calculation errors (E) are automatically displayed, but the pay in progress (P) and updated by user (U) errors are not. If pay in progress or updated by user errors exist and are not corrected during the Calculate Deductions process, the Confirm Deductions process will fail.</p> <p>The Payline Calculation Status option is:</p> <ul style="list-style-type: none"> • Set to <i>Calculated</i> if no errors occur during the Calculate Deductions run. • Set to <i>Confirmed</i> if no errors occur during the Confirm Deductions run. • Reset to <i>Calculated</i> after the Deduction Unconfirm process is run.

13

Running Exports and Imports

Understanding Data Exchanges

Payroll Interface enables you to exchange data between PeopleSoft HCM and a third-party payroll system. Data is exported from PeopleSoft HCM to the third-party payroll system using either a file or table. Data is imported from the third-party payroll system back into PeopleSoft HCM using *only* an ASCII formatted file. You use the same run-control process to export or import data.

Note

If you maintain deduction information, you must run the Calculate Deductions and Confirm Deductions processes before running the Export process.

See [Understanding Deduction Processing](#).

See *PeopleTools: Process Scheduler*

Exporting Data

Use the Export Application Engine process (PI_INRUN) to export data. The Export process retrieves, maps, and exports data using the definitions and processing routines that are set up through the export interface. When the Export process is complete (the export file or the export table is created), the third-party payroll vendor uses the appropriate software to load the data and process the payroll.

The export process includes three phases: select, compare, and export.

- During the select phase, employee payroll data is retrieved from the PeopleSoft HCM tables.
- During the compare phase, the selected data is compared against the data from the previous export run. The comparison phase identifies any data changes that have occurred since the last export.
- During the export phase, the data is exported to either a flat file or a table.

A full-records export performs the select and export phases; all employee data is exported. A changes-only export performs the select, compare, and export phases; only employee data that has changed is exported.

To export data:

1. Set up and run the Export process.
See [Exporting or Importing Data](#).
2. Review the results of the Export process run.
See [Reviewing Exports or Imports](#).

Importing Data

Use the Import Application Engine process (PI_INRUN) to import data. The Import process loads the processed payroll information (check detail and balance data) generated by the third-party payroll system into seven Payroll Interface import tables for online viewing and reporting. Further processing or technical configuration may be required to check the validity of the data or to ensure that employee-level data can be accessed in a secure manner.

To import data:

1. Obtain a copy of the ASCII import file from the third-party payroll vendor.
2. (Optional) If the file is tab-delimited, convert it to comma-delimited.
See [Converting Tab-Delimited Import Files](#).
3. Store the import file in the location that is defined in the File Handle Table component.
4. Set up and run the Import process.
See [Exporting or Importing Data](#).
5. Review the results of the Import process run.
See [Exporting or Importing Data](#).

Exporting or Importing Data

To export or import data, use the Import/Export Payroll Data (PI_RUNCTL_PNL) component.

Pages Used to Export and Import Data

Page Name	Definition Name	Usage
Import/Export Payroll Data Page	PI_RUNCTL_PNL	Select the export or import process options and run the P.I. Export/Import Driver Application Engine process (PI_INRUN) to export or import data.

Import/Export Payroll Data Page

Use the Import/Export Payroll Data page (PI_RUNCTL_PNL) to select the export or import process options and run the P.I. Export/Import Driver Application Engine process (PI_INRUN) to export or import data.

Navigation:

Payroll Interface, and then **Payroll Data Exchanges**, and then **Import/Export Payroll Data**, and then **Import/Export Payroll Data**

This example illustrates the fields and controls on the Import/Export Payroll Data page.

Import/Export Payroll Data

Run Control ID 1

Report Manager

Process Monitor

Run

Run Parameters

*Pay Run ID KU7-00-01 Run Type

*PI Run Option *PI Run Number

Check Point Interval

Export Options

*Select Type Run Select and Compare Only

*Export Change or Full Exclude Calculated Deductions

Active Employees

Reprocess

Compare Export

Run Parameters

Field or Control	Description
Run Type	Select which process to run, either <i>Export</i> or <i>Import</i> .
PI Run Option (Payroll Interface run option)	Select a run option: <ul style="list-style-type: none"> <i>New</i>: Increments the payroll interface run number and runs a new <i>Export</i> process. <i>Reprocess</i>: Reruns an existing <i>Export</i> process. You must select the payroll interface run number of the process that you want to reprocess. <i>Restart</i>: Restarts the most recent <i>Export</i> process (the most recently selected payroll interface run number).
PI Run Number	Each time that you run a new <i>Export</i> process, the system increments the run number. During the compare phase, the <i>Export</i> process uses the run numbers to compare the results of the current export with the results of the previous export.
Check Point Interval (check point interval in minutes)	Select to specify how often, in minutes, the system should commit during a process run. Note: To determine the interval using number of employees rather than number of minutes — that is, to use the Installation Table - Third Party/System page, Commit After Empl Processed (commit after employee processed) field value — leave the Check Point Interval field blank or enter 0.

Export Options

Use this group box to select options for the Export process. (These options do not apply to the Import process).

Field or Control	Description
Select Type	<p>Select which employees to process:</p> <ul style="list-style-type: none"> • <i>All Employees in Group</i>: Process all employees in the pay group. • <i>Manually Select</i>: Process those employees that are specified in the <i>Selected Employees</i> group box. • <i>SmartSelect</i>: Process those employees that are in the pay group for whom online changes have been made since the last export run. If the selection process finds that all employees in the group have not yet been run for this company and pay group combination, <i>SmartSelect</i> is overridden at the pay group level and changed to <i>All Employees in Group</i>. <p>Note: Before selecting this option, you <i>must</i> activate SmartSelect by attaching a PeopleCode function to all EMPLID-keyed tables that are defined in the PS Tables component.</p> <p>See Working with Smart Select.</p> <p>Note: (USF) For National Finance Center (NFC) interface definitions, the Select Type field does not appear. The Output Files (s) field appears instead. You can output all files or just the EPIC file or PMSO file.</p> <p>See Working with Smart Select.</p>
Export Change or Full	<p>Select to identify which employee records to process:</p> <ul style="list-style-type: none"> • <i>Chgs Only</i> (changes only): Process only employee records with changed data. • <i>Full Recs</i> (full records): Process all employee records. <p>Note: If you attempt to run a changes-only export (select, compare, export) before running a full-records export (select, export), processing becomes <i>Full Recs</i> by default. To perform a changes-only export, data from a previous run must be in place.</p>
Run Select and Compare Only	<p>Select this option to run the Export process but not create the export file.</p> <p>This option enables you to review the export data before creating the export file. It also enables you to run the Export process at one location and create the export file at another location.</p> <p>Note: If you select this option, use the Complete Export to File (complete export to external file) component to create the export file.</p>

Field or Control	Description
Exclude Calculated Deductions	Select if you do not want to process deductions. Note: <i>Always</i> select this option if you do not maintain deductions (if you never run the Calculate Deductions and Confirm Deductions processes). See Understanding Deduction Processing .
Active Employees	Select to process only employees whose employee status is defined as active (on the System Table - Interface System Table 2 page, <i>Employee Status</i> field). Note: Do not select this option if you want to process all employees, regardless of their status (for example, for year-end processing).

Reprocess

Field or Control	Description
Reprocess	Select to rerun a previously completed Export process. <ul style="list-style-type: none"> <i>Compare:</i> Rerun the Export process compare and export phases. This option deletes the data from the PS_PI_PARTIC, PS_PI_PARTIC_EXPT, and PS_PI_MESSAGE tables where the PI_RUN_NUMBER matches the reprocess PI_RUN_NUMBER. The Export process performs the select, compare, and export phases. <i>Export:</i> Rerun the Export process export phase. This option uses the data that is currently stored in the PS_PI_PARTIC, PS_PI_PARTIC_EXPT, and PS_PI_MESSAGE tables where the PI_RUN_NUMBER matches the reprocess PI_RUN_NUMBER. The Export process performs the export phase only. Note: To reprocess an Export run, you usually select the <i>Compare</i> option.

Selected Employees

This group box appears only when you select **Select Type, Manually Select**. Manually enter each employee that you want to include in the Export process.

Field or Control	Description
Employee ID and Empl Record (employee record)	Enter the employee identifiers as defined on the Employee Table - Interface Employee Table page.

Creating the Export File Separately

To create the export file separately, use the Complete Export to File (PI_RUNCTL_AE) component.

Pages Used to Create the Export File Separately

Page Name	Definition Name	Usage
Complete Export to File Page	PI_RUNCTL_AE_PNL	Select the export file run options and run the P.I. External File I/O Application Engine process (PI_EXTFL) to create the export file separately. Use this page only if you have already run the Export process using the Import/Export Payroll Data page with the Run Select and Compare Only option selected.

Complete Export to File Page

Use the Complete Export to File page (PI_RUNCTL_AE_PNL) to select the export file run options and run the P.I. External File I/O Application Engine process (PI_EXTFL) to create the export file separately.

Navigation:

Payroll Interface, and then **Payroll Data Exchanges**, and then **Complete Export to File**, and then **Complete Export to File**

This example illustrates the fields and controls on the Complete Export to File page.

Complete Export to File

Run Control ID PS Report Manager Process Monitor Run

Run Parameters

*Pay Run ID US KU1 Weekly Pay 01 Jan 04

Run Type

*PI Run Option

*PI Run Number

Note

Use this page only if you have already run the Export process using the Import/Export Payroll Data page with the **Run Select and Compare Only** option selected.

Field or Control	Description
Pay Run ID	Select the pay run ID of the export run that you want to complete.
Run Type	Select and enter <i>Export</i> .
PI Run Option (payroll interface run option)	Select to enter a run option.
Payroll Interface Run Number	Select to enter the run number that corresponds to the pay run ID.

Converting Tab-Delimited Import Files

To convert tab-delimited import files, use the Convert Tab Delimiter (RUNCTL_PICNVT_TAB) component.

Pages Used to Convert Tab-Delimited Import Files

Page Name	Definition Name	Usage
Convert Tab Delimiter Page	RUNCTL_PICNVT_TAB	Select the tab-delimited import file options to run the Convert Tab Delimited Files SQR Report process (PI002) to convert a tab-delimited import file.

Convert Tab Delimiter Page

Use the Convert Tab Delimiter page (RUNCTL_PICNVT_TAB) to select the tab-delimited import file options to run the Convert Tab Delimited Files SQR Report process (PI002) to convert a tab-delimited import file.

Navigation:

Payroll Interface, and then **Payroll Data Exchanges**, and then **Convert Tab Delimiter**, and then **Convert Tab Delimiter**

This example illustrates the fields and controls on the Convert Tab Delimiter page.

Convert Tab Delimiter

Run Control ID PS Report Manager Process Monitor Run

Run Parameters

*System ID	<input type="text" value="CSV"/>		CSV Sample Layout
Configuration ID	<input type="text" value="CSV"/>		CSV Sample Config ID

Note

Use this page to convert tab-delimited import files. Because COBOL automatically changes a tab to a space when reading a file, you must convert tab-delimited files into comma-delimited files before importing them.

Field or Control	Description
System ID	Select the system ID that identifies the third-party payroll system.
Configuration ID	Select the configuration ID that identifies the import files to be converted.

Reviewing Exports or Imports

To review exports and imports, use the Error Messages (PI_MESSAGES), Run Table (INTERFACE_RUN_TBL), Export Details (INTERFACE_PARTIC), Table Export (PI_PARTIC_EXTBL), Check Summary (PI_CHECK_SUMM), Earnings Balances (INTERFACE_EARN_BAL), Deduction Balances (INTERFACE_DED_BAL), and Tax Balances (INTERFACE_TAX_BAL) components.

Pages Used to Review Exports or Imports

Page Name	Definition Name	Usage
Interface Messages Page	PI_MESSAGES	Export/Import Process Review error messages generated by Payroll Interface. The Error Key field indicates the Payroll Interface field that has the problem. Refer to PSCPMSG.CBL (COBOL) for technical troubleshooting.
Run Table Page	PI_RUNTBL_PNL	Export/Import Process Review information about import and export runs.
Export Details Page	PI_PARTIC_PNL	Export Process Review the results of the Export process. The data shown here represents the contents of the PI_PARTIC_EXPT table.
Table Export Page	PI_PARTIC_EXTBL	Export Process Review the results of the Export process when writing data to a table. The data shown here represents the contents of the PI_PARTIC_EXTBL table (the export table).

Page Name	Definition Name	Usage
Check Summary Page	PI_CHECK_SUMM	Import Process Review check data that is imported from your third-party payroll system. Select the Tax Detail link to view a page with tax details for the check summary that you're reviewing.
Check Tax Detail Page	PI_CHECK_SUMM_S1	Import Process Review tax details for a check summary.
Earnings Balances Page	PI_ERNBAL_PNL	Import Process Review earnings balances that are imported from your payroll system.
Deduction Balances Page	PI_DEDBAL_PNL	Import Process Review deduction balances that are imported from your payroll system.
Tax Balances Page	PI_TAXBAL_PNL	Import Process Review tax balances that are imported from your payroll system.

PeopleSoft Payroll Interface Reports

PeopleSoft Payroll Interface Reports: A to Z

Tables in this topic list PeopleSoft Payroll Interface reports, sorted by report ID.

For more information about running the reports, refer to:

- The corresponding topic in this product documentation.
- *PeopleTools: Process Scheduler*
- *PeopleTools: BI Publisher for PeopleSoft*
- *PeopleTools: SQL Language Reference for PeopleSoft*

For samples of the reports, see the Report Samples that are published with this online documentation.

Data Reports

This table lists and describes the data reports that are included in PeopleSoft Payroll Interface, listed alphanumerically.

Report ID and Report Name	Description	Navigation	Run Control Page
Pay031 Benefit Deductions Register	For each company/pay group, lists the deduction type and calculated deduction amount for each employee. This report can be run only after the Calculate Deductions process is run.	Payroll Interface , and then Reports , and then Benefit Deductions Register , and then Benefit Deductions Register	RUNCTL_PAYINIT2
PI001 Export Changes Report	Lists detailed information for employees who will be included in the export file, including both old and new values for fields that changed since the last export file was created.	Payroll Interface , and then Reports , and then Export Changes , and then Export Changes Report	RUNCTL_PIEXP2
TAX016 Default Tax Data Report	(USA) Lists employees with default data in their Tax records.	Payroll Interface , and then Reports , and then Default Tax Data USA , and then Default Tax Data Report	RUNCTL_FRMTHRU_PA Y

Report ID and Report Name	Description	Navigation	Run Control Page
TAX016CN Default Tax Data Report	(CAN) Provides the data that is auto-generated by the system, such as the employee's hire date, default net claim amount from the Canadian Tax Tables, and province. This report also includes the provincial tax credit amounts from the Canadian Income Tax Data record.	Payroll Interface , and then Reports , and then Default Tax Data CAN , and then Default Tax Data Report	RUNCTL_FRMTHRU_PA Y
TAX019 Employee Tax Information Report	(USA) Provides an individual listing of the employee's tax withholding information.	Payroll Interface , and then Reports , and then Employee Tax Information USA , and then Employee Tax Information Report	RUNCTL_TAX019
TAX019 Employee Tax Information Report	(CAN) Provides an individual listing of the employee's tax withholding information.	Payroll Interface , and then Reports , and then Employee Tax Information CAN , and then Employee Tax Information Report	RUNCTL_TAX019
TAX100 W-4 Exemptions Report	(USA) Lists all employees in each company who are exempt from federal income tax withholding.	Payroll Interface , and then Reports , and then W-4 Exemption , and then W-4 Exemptions Report	RUNCTL_TAX100
TAX100CN Exemption Report	(CAN) Lists all employees whose Canadian or Quebec Tax Data records indicate that they are exempt from income tax withholding, are exempt from unemployment insurance payments, or have fewer than 12 months subject to Canada or Quebec pension plan contributions.	Payroll Interface , and then Reports , and then Exemption CAN , and then Exemption Report	RUNCTL_TAX100CN

Report ID and Report Name	Description	Navigation	Run Control Page
TAX103 Reset W-4 Exempt List	(USA) Identifies employees who have not yet filed a new Form W-4 by the due date to continue their exemption status, and inserts a new Tax record to reset the special withholding tax status and tax status of each of those employees. The report also updates future-dated records that currently specify exempt status.	Payroll Interface , and then Reports , and then Reset W-4 Exempt List , and then Reset W-4 Exempt List	RUNCTL_TAX103
TAX107 W-4 Audit Report	(USA) Lists all employees who either created or updated their W4 information on the web.	Payroll Interface , and then Reports , and then W-4 Audit , and then W-4 Audit Report	RUNCTL_TAX107

Payroll Reports

This table lists and describes the payroll reports that are included in PeopleSoft Payroll Interface, listed alphanumerically.

Report ID and Report Name	Description	Navigation	Run Control Page
PAY703 General Ded/ Frequency Report (general deduction/ frequency report)	Lists information from the General Deduction/ Deduction Frequency Table, which contains payroll deductions that do not fit into a category covered by a benefit table, such as United Way, union dues, or parking fees.	Set Up HCM , and then Product Related , and then Payroll Interface , and then Payroll Reports , and then General Deduction/ Frequency , and then General Ded/ Frequency Report	PRCSRUNCNTL
PAY704 Deduction/Frequency Report	Lists information from the Deduction/ Deduction Frequency Table, which contains deduction priority, tax effect, and frequency for benefit deductions and general deductions.	Set Up HCM , and then Product Related , and then Payroll Interface , and then Payroll Reports , and then Deduction/ Frequency , and then Deduction/Frequency Report	PRCSRUNCNTL

Report ID and Report Name	Description	Navigation	Run Control Page
PAY705A/B Deduction Class Report	Lists deduction classification codes from the Deduction Table.	Set Up HCM , and then Product Related , and then Payroll Interface , and then Payroll Reports , and then Deduction Class , and then Deduction Class Report	PRCSRUNCNTL
PAY708 Shift Report	Lists information from the Shift table, where you identify the work shifts to which you can assign an employee. Because it contains the rate or factor that the system uses to calculate the shift differential, this table works with the Earnings and Special Accumulator Tables to calculate earnings.	Set Up HCM , and then Product Related , and then Payroll Interface , and then Payroll Reports , and then Shift Table , and then Shift Report	PRCSRUNCNTL
PAY709 Wage Loss Plan Report	(CAN) Lists information from the Wage Loss Plan Table for Canadian employers.	Set Up HCM , and then Product Related , and then Payroll Interface , and then Payroll Reports , and then Wage Loss Plan CAN , and then Wage Loss Plan Report	PRCSRUNCNTL
PAY711 Pay Group Report	Lists pay groups, effective dates, and processing characteristics from the Pay Group Table.	Set Up HCM , and then Product Related , and then Payroll Interface , and then Payroll Reports , and then Pay Group Table , and then Pay Group Report	PRCSRUNCNTL
PAY712A/B/C Earnings Report	Lists earnings types and their payroll characteristics.	Set Up HCM , and then Product Related , and then Payroll Interface , and then Payroll Reports , and then Earnings Table , and then Earnings Report	PRCSRUNCNTL

Report ID and Report Name	Description	Navigation	Run Control Page
PAY714 Pay Calendar Report	Lists information from the Pay Calendar Table, which contains the cycles that you create for payroll processing by pay group. Each entry in the table corresponds to a pay period for a pay group.	Set Up HCM , and then Product Related , and then Payroll Interface , and then Payroll Reports , and then Pay Calendar , and then Pay Calendar Report	PRCSRUNCNTL
PAY717 Earnings Program Report	Lists information from the Earnings Program Table.	Set Up HCM , and then Product Related , and then Payroll Interface , and then Payroll Reports , and then Earnings Program , and then Earnings Program Report	PRCSRUNCNTL
TAX702 Federal/State Tax Report	(USA) Prints information from the State Tax Table and the State Other Tax Table, which store the most current tax rates and other parameters that are used in calculating state and federal withholding, disability, and unemployment taxes.	Set Up HCM , and then Product Related , and then Payroll Interface , and then Payroll Reports , and then Federal/State Tax , and then Federal/State Tax Report	PRCSRUNCNTRL
TAX703 Local Tax Report	(USA) Lists information from the Local Tax Table, which contains calculations for local income taxes.	Set Up HCM , and then Product Related , and then Payroll Interface , and then Payroll Reports , and then Local Tax , and then Local Tax Report	PRCSRUNCNTRL
TAX705 Company Local Tax Report	(USA) Lists information from the Company Local Tax Table, which identifies the localities for which your company collects and pays taxes.	Set Up HCM , and then Product Related , and then Payroll Interface , and then Payroll Reports , and then Agency Local Tax USF , and then Company Local Tax Report	PRCSRUNCNTRL
TAX707 State Tax Rate Report	(USA) Lists information from the State Tax Rate Table, which contains bracket rates that are needed for calculating state and federal taxes.	Set Up HCM , and then Product Related , and then Payroll Interface , and then Payroll Reports , and then State Tax Rate , and then State Tax Rate Report	PRCSRUNCNTRL

Interface Definition Reports

This table lists and describes the interface definition reports that are included in PeopleSoft Payroll Interface, listed alphanumerically.

Report ID and Report Name	Description	Navigation	Run Control Page
PI701 System Table Listing	Shows each system ID, its description, and its effective date, along with other data on the System Interface Table.	Set Up HCM , and then Product Related , and then Payroll Interface , and then Interface Definition Reports , and then System Table Listing , and then System Table Listing	PRCSRUNCNTL
PI702 PS Record Listing	Lists PeopleSoft tables and views that you can use in PeopleSoft Payroll Interface.	Set Up HCM , and then Product Related , and then Payroll Interface , and then Interface Definition Reports , and then PS Record Listing , and then PS Record Listing	PRCSRUNCNTL
PI703 PS Record-Field Listing	Lists each field on the PeopleSoft tables and views that you can use in PeopleSoft Payroll Interface.	Set Up HCM , and then Product Related , and then Payroll Interface , and then Interface Definition Reports , and then PS Record-Field Listing , and then PS Record-Field Listing	PRCSRUNCNTL
PI704 Field Listing	Shows fields that are defined for the third-party payroll system and how PeopleSoft fields are mapped to them for both import and export processing.	Set Up HCM , and then Product Related , and then Payroll Interface , and then Interface Definition Reports , and then Field Listing , and then Field Listing	PRCSRUNCNTL
PI705 Field-Translation Listing	For each defined system ID, lists the third-party payroll system's fields along with the PeopleSoft source fields. Also lists translate values.	Set Up HCM , and then Product Related , and then Payroll Interface , and then Interface Definition Reports , and then Field-Translation Listing , and then Field-Translation Listing	PRCSRUNCNTL

Report ID and Report Name	Description	Navigation	Run Control Page
PI706 Instance Listing	Displays each instance of a PeopleSoft record to be exported to the third-party payroll system.	Set Up HCM , and then Product Related , and then Payroll Interface Definition Reports , and then Instance Listing , and then Instance Listing	PRCSRUNCNTL
PI707 Process Listing	Displays descriptions for each defined COBOL process that filters data before creating the export file.	Set Up HCM , and then Product Related , and then Payroll Interface Definition Reports , and then Process Listing , and then Process Listing	PRCSRUNCNTL
PI708 Process Values	Displays values that are returned from a special COBOL process. These values are used in the field translation process.	Set Up HCM , and then Product Related , and then Payroll Interface Definition Reports , and then Process Values , and then Process Values	PRCSRUNCNTL
PI709 Definition Table-File	Lists each file that is used in PeopleSoft Payroll Interface.	Set Up HCM , and then Product Related , and then Payroll Interface Definition Reports , and then Definition Table-File , and then Definition Table-File	PRCSRUNCNTL
PI710 Definition Table-Record	Lists the layout of each record that is used to format import and export files.	Set Up HCM , and then Product Related , and then Payroll Interface Definition Reports , and then Definition Table-Record , and then Definition Table-Record	PRCSRUNCNTL
PI711 Definition Table-Field	Lists the layout and content of each field for every record on each file that is used in PeopleSoft Payroll Interface.	Set Up HCM , and then Product Related , and then Payroll Interface Definition Reports , and then Definition Table-Field , and then Definition Table-Field	PRCSRUNCNTL

Report ID and Report Name	Description	Navigation	Run Control Page
PI712 Configuration Listing	Displays processing groups, file names, and descriptions that are needed for the third-party payroll system.	Set Up HCM , and then Product Related , and then Payroll Interface Definition Reports , and then Configuration Listing , and then Configuration Listing	PRCSRUNCNTL
PI713 Group Listing	Lists group IDs that represent fields to be processed together in the export file.	Set Up HCM , and then Product Related , and then Payroll Interface Definition Reports , and then Group Listing , and then Group Listing	PRCSRUNCNTL
PI714 Employee Listing	Where they differ, lists each PeopleSoft employee ID along with the third-party payroll system's employee ID.	Set Up HCM , and then Product Related , and then Payroll Interface Definition Reports , and then Employee Listing	PRCSRUNCNTL
PI715 File Handle Listing	Displays each file handle, file name, and description.	Set Up HCM , and then Product Related , and then Payroll Interface Definition Reports , and then File Handle Listing , and then File Handle Listing	PRCSRUNCNTL