

# Oracle® Database

## Backup and Recovery Reference



21c  
F31837-08  
March 2024

The Oracle logo, consisting of a solid red square with the word "ORACLE" in white, uppercase, sans-serif font centered within it.

ORACLE®

Oracle Database Backup and Recovery Reference, 21c

F31837-08

Copyright © 2023, 2024, Oracle and/or its affiliates.

Primary Authors: Padmaja Potineni, Ramya P

Contributors: Prakash Jashnani, Jean-Francois VERRIER, K. Weill, L. Ashdown, T. Bednar, A. Beldalker, T. Chien, M. Dilman, S. Dizdar, W. Fisher, S. Fogel, R. Guzman, S. Haisley, W. Hu, A. Hwang, A. Joshi, V. Krishnaswamy, J. W. Lee, V. Moore, S. Nagaraja Rao, M. Olagappan, V. Panteleenko, B. Patel, C. Pedregal-Martin, S. Ranganathan, S. Samaranayake, F. Sanchez, V. Schupmann, V. Srihari, M. Susairaj, M. Stewart, M. Townsend, S. Wertheimer, W. Yang, R. Zijlstra, Matthew Arrocha, Silvio Martinez

This software and related documentation are provided under a license agreement containing restrictions on use and disclosure and are protected by intellectual property laws. Except as expressly permitted in your license agreement or allowed by law, you may not use, copy, reproduce, translate, broadcast, modify, license, transmit, distribute, exhibit, perform, publish, or display any part, in any form, or by any means. Reverse engineering, disassembly, or decompilation of this software, unless required by law for interoperability, is prohibited.

The information contained herein is subject to change without notice and is not warranted to be error-free. If you find any errors, please report them to us in writing.

If this is software, software documentation, data (as defined in the Federal Acquisition Regulation), or related documentation that is delivered to the U.S. Government or anyone licensing it on behalf of the U.S. Government, then the following notice is applicable:

U.S. GOVERNMENT END USERS: Oracle programs (including any operating system, integrated software, any programs embedded, installed, or activated on delivered hardware, and modifications of such programs) and Oracle computer documentation or other Oracle data delivered to or accessed by U.S. Government end users are "commercial computer software," "commercial computer software documentation," or "limited rights data" pursuant to the applicable Federal Acquisition Regulation and agency-specific supplemental regulations. As such, the use, reproduction, duplication, release, display, disclosure, modification, preparation of derivative works, and/or adaptation of i) Oracle programs (including any operating system, integrated software, any programs embedded, installed, or activated on delivered hardware, and modifications of such programs), ii) Oracle computer documentation and/or iii) other Oracle data, is subject to the rights and limitations specified in the license contained in the applicable contract. The terms governing the U.S. Government's use of Oracle cloud services are defined by the applicable contract for such services. No other rights are granted to the U.S. Government.

This software or hardware is developed for general use in a variety of information management applications. It is not developed or intended for use in any inherently dangerous applications, including applications that may create a risk of personal injury. If you use this software or hardware in dangerous applications, then you shall be responsible to take all appropriate fail-safe, backup, redundancy, and other measures to ensure its safe use. Oracle Corporation and its affiliates disclaim any liability for any damages caused by use of this software or hardware in dangerous applications.

Oracle®, Java, MySQL, and NetSuite are registered trademarks of Oracle and/or its affiliates. Other names may be trademarks of their respective owners.

Intel and Intel Inside are trademarks or registered trademarks of Intel Corporation. All SPARC trademarks are used under license and are trademarks or registered trademarks of SPARC International, Inc. AMD, Epyc, and the AMD logo are trademarks or registered trademarks of Advanced Micro Devices. UNIX is a registered trademark of The Open Group.

This software or hardware and documentation may provide access to or information about content, products, and services from third parties. Oracle Corporation and its affiliates are not responsible for and expressly disclaim all warranties of any kind with respect to third-party content, products, and services unless otherwise set forth in an applicable agreement between you and Oracle. Oracle Corporation and its affiliates will not be responsible for any loss, costs, or damages incurred due to your access to or use of third-party content, products, or services, except as set forth in an applicable agreement between you and Oracle.

For information about Oracle's commitment to accessibility, visit the Oracle Accessibility Program website at <http://www.oracle.com/pls/topic/lookup?ctx=acc&id=docacc>.

# Contents

## Preface

---

Audience	ix
Documentation Accessibility	ix
Related Documentation	ix
Conventions	x

## 1 About RMAN Commands

---

1.1 RMAN Syntax Diagrams	1-1
1.1.1 Keywords in RMAN Syntax	1-2
1.1.2 Placeholders in RMAN Syntax	1-2
1.1.3 Quotes in RMAN Syntax	1-3
1.2 Format of RMAN Commands	1-3
1.3 About RMAN Reserved Words	1-3
1.4 Summary of RMAN Commands	1-4
1.5 Summary of RMAN Subclauses	1-6

## 2 RMAN Commands: @ (at sign) to QUIT

---

2.1 @ (at sign)	2-2
2.2 @@ (double at sign)	2-3
2.3 ADVISE FAILURE	2-5
2.4 ALLOCATE CHANNEL	2-8
2.5 ALLOCATE CHANNEL FOR MAINTENANCE	2-11
2.6 BACKUP	2-15
2.7 CATALOG	2-59
2.8 CHANGE	2-64
2.9 CONFIGURE	2-73
2.10 CONNECT	2-97
2.11 CONVERT	2-101
2.12 CREATE CATALOG	2-115
2.13 CREATE SCRIPT	2-118
2.14 CROSSCHECK	2-121

2.15	DELETE	2-125
2.16	DELETE SCRIPT	2-131
2.17	DESCRIBE	2-133
2.18	DROP CATALOG	2-134
2.19	DROP DATABASE	2-135
2.20	DUPLICATE	2-136
2.21	EXECUTE SCRIPT	2-164
2.22	EXIT	2-166
2.23	FLASHBACK DATABASE	2-167
2.24	GRANT	2-175
2.25	HOST	2-178
2.26	IMPORT CATALOG	2-179
2.27	LIST	2-182
2.28	PRINT SCRIPT	2-204
2.29	QUIT	2-206

### 3 RMAN Commands: RECOVER to VALIDATE

---

3.1	RECOVER	3-2
3.2	REGISTER DATABASE	3-26
3.3	RELEASE CHANNEL	3-27
3.4	REPAIR FAILURE	3-30
3.5	REPLACE SCRIPT	3-34
3.6	REPORT	3-37
3.7	RESET DATABASE	3-46
3.8	RESTORE	3-48
3.9	RESYNC CATALOG	3-74
3.10	REVOKE	3-78
3.11	RMAN	3-80
3.12	RUN	3-85
3.13	SEND	3-87
3.14	SET	3-89
3.15	SHOW	3-101
3.16	SHUTDOWN	3-104
3.17	SPOOL	3-106
3.18	SQL	3-107
3.19	SQL (Quoted)	3-110
3.20	STARTUP	3-111
3.21	SWITCH	3-113
3.22	TRANSPORT TABLESPACE	3-117
3.23	UNREGISTER	3-122

3.24	UPGRADE CATALOG	3-125
3.25	VALIDATE	3-127

## 4 RMAN Subclauses

---

4.1	allocOperandList	4-2
4.2	archivelogRecordSpecifier	4-5
4.3	completedTimeSpec	4-10
4.4	connectStringSpec	4-11
4.5	datafileSpec	4-14
4.6	dbObject	4-15
4.7	deviceSpecifier	4-16
4.8	fileNameConversionSpec	4-17
4.9	forDbUniqueNameOption	4-19
4.10	foreignFileSpec	4-20
4.11	foreignlogRecordSpecifier	4-24
4.12	formatSpec	4-25
4.13	keepOption	4-28
4.14	listObjList	4-30
4.15	maintQualifier	4-33
4.16	maintSpec	4-35
4.17	obsOperandList	4-37
4.18	recordSpec	4-38
4.19	sizeSpec	4-40
4.20	tempfileSpec	4-40
4.21	toDestSpec	4-41
4.22	untilClause	4-42

## 5 Recovery Catalog Views

---

5.1	Summary of RMAN Recovery Catalog Views	5-1
5.2	RC_ARCHIVED_LOG	5-4
5.3	RC_BACKUP_ARCHIVELOG_DETAILS	5-6
5.4	RC_BACKUP_ARCHIVELOG_SUMMARY	5-8
5.5	RC_BACKUP_CONTROLFILE	5-9
5.6	RC_BACKUP_CONTROLFILE_DETAILS	5-10
5.7	RC_BACKUP_CONTROLFILE_SUMMARY	5-11
5.8	RC_BACKUP_COPY_DETAILS	5-12
5.9	RC_BACKUP_COPY_SUMMARY	5-14
5.10	RC_BACKUP_CORRUPTION	5-14
5.11	RC_BACKUP_DATAFILE	5-16

5.12	RC_BACKUP_DATAFILE_DETAILS	5-19
5.13	RC_BACKUP_DATAFILE_SUMMARY	5-20
5.14	RC_BACKUP_FILES	5-21
5.15	RC_BACKUP_PIECE	5-25
5.16	RC_BACKUP_PIECE_DETAILS	5-27
5.17	RC_BACKUP_REDOLOG	5-30
5.18	RC_BACKUP_SET	5-31
5.19	RC_BACKUP_SET_DETAILS	5-34
5.20	RC_BACKUP_SET_SUMMARY	5-36
5.21	RC_BACKUP_SPFILE	5-37
5.22	RC_BACKUP_SPFILE_DETAILS	5-38
5.23	RC_BACKUP_SPFILE_SUMMARY	5-39
5.24	RC_CHECKPOINT	5-39
5.25	RC_CONTROLFILE_COPY	5-39
5.26	RC_COPY_CORRUPTION	5-41
5.27	RC_DATABASE	5-42
5.28	RC_DATABASE_BLOCK_CORRUPTION	5-43
5.29	RC_DATABASE_INCARNATION	5-44
5.30	RC_DATAFILE	5-45
5.31	RC_DATAFILE_COPY	5-48
5.32	RC_DISK_RESTORE_RANGE	5-51
5.33	RC_LOG_HISTORY	5-51
5.34	RC_OFFLINE_RANGE	5-52
5.35	RC_PDBS	5-53
5.36	RC_PLUGGABLE_DATABASE_INC	5-53
5.37	RC_PROXY_ARCHIVEDLOG	5-55
5.38	RC_PROXY_ARCHIVELOG_DETAILS	5-57
5.39	RC_PROXY_ARCHIVELOG_SUMMARY	5-58
5.40	RC_PROXY_CONTROLFILE	5-58
5.41	RC_PROXY_COPY_DETAILS	5-60
5.42	RC_PROXY_COPY_SUMMARY	5-62
5.43	RC_PROXY_DATAFILE	5-63
5.44	RC_REDO_LOG	5-65
5.45	RC_REDO_THREAD	5-66
5.46	RC_RESTORE_POINT	5-67
5.47	RC_RESTORE_RANGE	5-67
5.48	RC_RESYNC	5-68
5.49	RC_RMAN_BACKUP_JOB_DETAILS	5-69
5.50	RC_RMAN_BACKUP_SUBJOB_DETAILS	5-71
5.51	RC_RMAN_BACKUP_TYPE	5-72
5.52	RC_RMAN_CONFIGURATION	5-72

5.53	RC_RMAN_OUTPUT	5-73
5.54	RC_RMAN_STATUS	5-74
5.55	RC_SBT_RESTORE_RANGE	5-76
5.56	RC_SITE	5-77
5.57	RC_STORED_SCRIPT	5-77
5.58	RC_STORED_SCRIPT_LINE	5-78
5.59	RC_TABLESPACE	5-78
5.60	RC_TEMPFILE	5-80
5.61	RC_UNUSABLE_BACKUPFILE_DETAILS	5-82

## A RMAN Reserved Words

---

A.1	List of RMAN Reserved Words	A-1
-----	-----------------------------	-----

## B RMAN Command Examples Quick Reference

---

## C Deprecated RMAN Syntax

---

## D RMAN Compatibility

---

D.1	About RMAN Compatibility	D-1
D.2	Determining the Recovery Catalog Schema Version	D-1
D.3	RMAN Compatibility Matrix	D-2
D.4	Cross-Version Compatibility of Recovery Catalog Exports and Imports	D-3
D.5	RMAN Compatibility: Scenario	D-4

## E Oracle Database Cloud Backup Module

---

## F Oracle Secure Backup (OSB) Cloud Module

---

F.1	About Backup on the Cloud Using Oracle Secure Backup Cloud Module	F-1
F.1.1	Configuration Parameters for the Oracle Secure Backup Cloud Module	F-2
F.2	Using Oracle Secure Backup Cloud Module on Amazon S3	F-3
F.2.1	Hardware and Software Prerequisites for Oracle Secure Backup Cloud Module	F-4
F.2.2	Registering for An Oracle Technology Network (OTN) Account	F-5
F.2.3	Signing Up For Amazon S3 - AWS Account	F-5
F.2.4	Getting Your AWS Credentials	F-6
F.2.5	Installing the OSB Cloud Module Library	F-6
F.2.6	Running the S3 Backup Installer	F-9

F.2.7	Storing Configuration Information in the RMAN Repository (Optional)	F-11
F.2.8	Using the OSB Web Services Library and First Backup	F-11
F.3	Securing OSB Cloud Module Backups	F-12
F.4	Helpful Links: Oracle Secure Backup Cloud Module	F-12
F.5	Troubleshooting the OSB Cloud Module	F-12

## Index

---



# Preface

This preface contains these topics:

- [Audience](#)
- [Documentation Accessibility](#)
- [Related Documentation](#)
- [Conventions](#)

## Audience

*Backup and Recovery Reference* is intended for database administrators who perform the following tasks:

- Use Recovery Manager (RMAN) to back up, restore, and recover Oracle databases
- Perform maintenance on RMAN backups of database files

To use this document, you must know the following:

- Relational database concepts and basic database administration as described in *Oracle Database Concepts* and the *Oracle Database Administrator's Guide*
- RMAN concepts and tasks as described in *Oracle Database Backup and Recovery User's Guide*
- The operating system environment under which you run Oracle Database

## Documentation Accessibility

For information about Oracle's commitment to accessibility, visit the Oracle Accessibility Program website at <http://www.oracle.com/pls/topic/lookup?ctx=acc&id=docacc>.

### Access to Oracle Support

Oracle customers that have purchased support have access to electronic support through My Oracle Support. For information, visit <http://www.oracle.com/pls/topic/lookup?ctx=acc&id=info> or visit <http://www.oracle.com/pls/topic/lookup?ctx=acc&id=trs> if you are hearing impaired.

## Related Documentation

For more information, see these Oracle resources:

- *Oracle Database Backup and Recovery User's Guide*
- *Oracle Database Reference*
- *Oracle Database Utilities*

Many of the examples in this book use the sample schemas of the seed database, which is installed by default when you install Oracle. Refer to *Oracle Database Sample Schemas* for information on how these schemas were created and how you can use them yourself.

## Conventions

The text in this reference adheres to the following conventions:

- UPPERCASE monospace  
RMAN keywords, SQL keywords, column headings in tables and views, and initialization parameters.
- lowercase monospace  
Variable text in RMAN examples.
- *italics*  
RMAN or SQL placeholders, that is, text that should not be entered as is, but represents a value to be entered by the user.



### See Also:

[About RMAN Commands](#) for more information about RMAN conventions

# 1

## About RMAN Commands

This chapter includes the following topics:

- [RMAN Syntax Diagrams](#)
- [Format of RMAN Commands](#)
- [RMAN Reserved Words](#)
- [Summary of RMAN Commands](#)
- [Summary of RMAN Subclauses](#)

### 1.1 RMAN Syntax Diagrams

Syntax descriptions are provided in this book for RMAN command-line constructs in graphic form or Backus Naur Form (BNF).

This section explains RMAN conventions exclusively. See *Oracle Database SQL Language Reference* for general information about how to interpret syntax diagrams and BNF notation.

Recovery Manager syntax diagrams use lines and arrows to show syntactic structure, as shown in the following example for the `CATALOG` command.

**catalog::=**

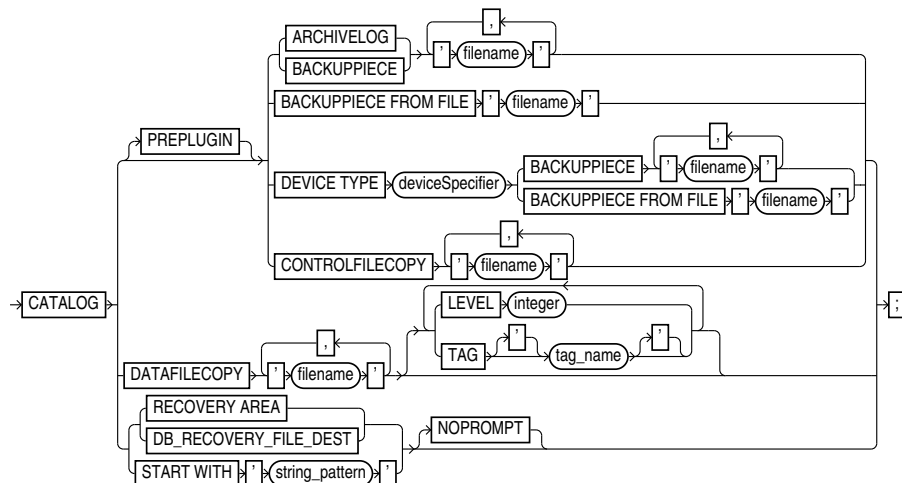

This section describes the components of syntax diagrams and gives examples of how to write RMAN commands. Syntax diagrams are made up of these items:

- [Keywords in RMAN Syntax](#)
- [Placeholders in RMAN Syntax](#)

- [Quotes in RMAN Syntax](#)

## 1.1.1 Keywords in RMAN Syntax

Keywords have special meanings in Recovery Manager syntax.

In the syntax diagrams, keywords appear in rectangular boxes and an uppercase font, like the word `CATALOG` in the example diagram. When used in text and code examples, RMAN keywords appear in uppercase, monospace font, for example, `CATALOG DATAFILECOPY`. You must use keywords in RMAN statements exactly as they appear in the syntax diagram, except that they can be either uppercase or lowercase.

## 1.1.2 Placeholders in RMAN Syntax

Placeholders in syntax diagrams indicate non-keywords.

In the syntax diagrams, placeholders appear in ovals, as in the word *integer* in the example diagram. When described in text, RMAN placeholders appear in lowercase italic, for example, '*filename*'.

Placeholders are usually:

- Names of database objects (*tablespace\_name*)
- Oracle data type names (*date\_string*)
- Subclauses (*datafileSpec*)

When you see a placeholder in a syntax diagram, substitute an object or expression of the appropriate type in the RMAN statement. For example, to write a `DUPLICATE TARGET DATABASE TO 'database_name'` command, use the name of the duplicate database you want to create, such as `dupdb`, for the *database\_name* placeholder in the diagram.

The only system-independent, valid environment variables in RMAN quoted strings are a question mark (?) for the Oracle home and an at-sign (@) for the SID. However, you can use operating system-specific environment variables on the target system within quoted strings. The environment variables are interpreted by the database server and not the RMAN client.

The following table shows placeholders that appear in the syntax diagrams and provides examples of the values you might substitute for them in your statements.

Placeholder	Description	Examples
Quoted strings such as ' <i>filename</i> ', ' <i>tablespace_name</i> ', ' <i>channel_name</i> ', ' <i>channel_parms</i> '	A string of characters contained in either single or double quotes. A quoted string may contain white space, punctuation, and RMAN and SQL keywords.	"?/dbs/cf.f" 'dev1'
Nonquoted strings such as <i>channel_id</i> , <i>tag_name</i> , <i>date_string</i>	A sequence of characters containing no white space and no punctuation characters and starting with an alphabetic character.	ch1
<i>integer</i>	Any sequence of only numeric characters.	67843

## 1.1.3 Quotes in RMAN Syntax

RMAN syntax diagrams contain some placeholder values that are enclosed in required or optional quotes.

The syntax diagrams show single quotes, though in all cases double quotes are also valid in RMAN syntax. For example, you may specify either '*filename*' or "*filename*".

## 1.2 Format of RMAN Commands

The RMAN language is free-form. Keywords must be separated by at least one white space character (such as a space, tab, or line break).

An RMAN command starts with a keyword corresponding to a command described in [RMAN Commands: @ \(at sign\) to QUIT](#), followed by arguments and ending with a semicolon, as shown in the syntax diagrams.

The following example shows an RMAN backup command:

```
BACKUP DATABASE;
```

A command can span multiple lines. For example, you can rewrite each keyword in the preceding command on a separate line as follows:

```
BACKUP
  DATABASE
;
```

The maximum length for an RMAN command in a single line is 4000 characters. When a command exceeds this length, you can either split the command into multiple commands or use multiple lines for the command (use the Enter key to make the command span multiple lines). For example, if a `BACKUP` command that backs up multiple data files exceeds 4000 characters, then you can either split this command into two separate `BACKUP` commands or make the single `BACKUP` command span multiple lines.

You can insert a comment by using a pound (#) character at any point in a line. After the # character, the remainder of the line is ignored. For example:

```
# run this command once each day
BACKUP INCREMENTAL LEVEL 1
  FOR RECOVER OF COPY      # using incrementally updated backups
  WITH TAG "DAILY_BACKUP" # daily backup routine
DATABASE;
```

## 1.3 About RMAN Reserved Words

The RMAN language contains reserved words, which are or have been used in RMAN commands. In general, avoid using reserved words in ways that conflict with their primary meaning in the RMAN command language.

If you must use a reserved word as an argument to an RMAN command (for example, as a file name, tablespace name, tag name, and so on), then surround it with single or double quotes. Otherwise, RMAN cannot parse your command correctly and generates an error. [Example 1-1](#) shows correct and incorrect usage of RMAN reserved words in RMAN commands.

### Example 1-1 Using Reserved Words as Arguments to RMAN Commands

```

ALLOCATE CHANNEL backup DEVICE TYPE DISK;           # incorrect
ALLOCATE CHANNEL "backup" DEVICE TYPE DISK;        # correct
BACKUP DATABASE TAG full;                          # incorrect
BACKUP DATABASE TAG 'full';                        # correct

```



#### See Also:

[RMAN Reserved Words](#) for a list of all the current reserved words

## 1.4 Summary of RMAN Commands

RMAN commands can be executed at the RMAN prompt, within a `RUN` command, or both.

All commands from previous RMAN releases work with the current release, although some commands and options are now deprecated (see [Deprecated RMAN Syntax](#)). For command-line options for the RMAN client, refer to [RMAN. Table 1-1](#) provides a functional summary of the RMAN commands.

**Table 1-1 Recovery Manager Commands**

Command	Purpose
<a href="#">@ (at sign)</a>	Run a command file.
<a href="#">@@ (double at sign)</a>	Run a command file in the same directory as another command file that is currently running. The @@ command differs from the @ command only when run from within a command file.
<a href="#">ADVISE FAILURE</a>	Display repair options.
<a href="#">ALLOCATE CHANNEL</a>	Establish a channel, which is a connection between RMAN and a database instance.
<a href="#">ALLOCATE CHANNEL FOR MAINTENANCE</a>	Allocate a channel in preparation for issuing maintenance commands such as <a href="#">DELETE</a> .
<a href="#">BACKUP</a>	Back up database files, copies of database files, archived logs, or backup sets.
<a href="#">CATALOG</a>	Add information about file copies and user-managed backups to the repository.
<a href="#">CHANGE</a>	Mark a backup piece, image copy, or archived redo log as having the status <code>UNAVAILABLE</code> or <code>AVAILABLE</code> ; remove the repository record for a backup or copy; override the retention policy for a backup or copy; update the recovery catalog with the <code>DB_UNIQUE_NAME</code> for the target database.
<a href="#">CONFIGURE</a>	Configure persistent RMAN settings. These settings apply to all RMAN sessions until explicitly changed or disabled.
<a href="#">CONNECT</a>	Establish a connection between RMAN and a target, auxiliary, or recovery catalog database.
<a href="#">CONVERT</a>	Convert data file formats for transporting tablespaces and databases across platforms.
<a href="#">CREATE CATALOG</a>	Create the schema for the recovery catalog.
<a href="#">CREATE SCRIPT</a>	Create a stored script and store it in the recovery catalog.

Table 1-1 (Cont.) Recovery Manager Commands

Command	Purpose
CROSSCHECK	Determine whether files managed by RMAN, such as archived logs, data file copies, and backup pieces, still exist on disk or tape.
DELETE	Delete backups and copies, remove references to them from the recovery catalog, and update their control file records to status <code>DELETED</code> .
DELETE SCRIPT	Delete a stored script from the recovery catalog.
DESCRIBE	List the column definitions of a table or view.
DROP CATALOG	Remove the schema from the recovery catalog.
DROP DATABASE	Delete the target database from disk and unregisters it.
DUPLICATE	Use backups of the target database to create a duplicate database that you can use for testing purposes or to create a standby database.
EXECUTE SCRIPT	Run an RMAN stored script.
EXIT	Quit the RMAN executable.
FLASHBACK DATABASE	Return the database to its state at a previous time or SCN.
GRANT	Grant privileges to a recovery catalog user.
HOST	Invoke an operating system command-line subshell from within RMAN or run a specific operating system command.
IMPORT CATALOG	Imports the metadata from one recovery catalog into a different recovery catalog.
LIST	Produce a detailed listing of backup sets or copies.
PRINT SCRIPT	Display a stored script.
QUIT	Exit the RMAN executable.
RECOVER	Apply redo log files and incremental backups to data files or data blocks restored from backup or data file copies, to update them to a specified time.
REGISTER DATABASE	Register the target database in the recovery catalog.
RELEASE CHANNEL	Release a channel that was allocated with an <code>ALLOCATE CHANNEL</code> command or <code>ALLOCATE CHANNEL FOR MAINTENANCE</code> command.
REPAIR FAILURE	Repair one or more failures recorded in the automated diagnostic repository.
REPLACE SCRIPT	Replace an existing script stored in the recovery catalog. If the script does not exist, then <code>REPLACE SCRIPT</code> creates it.
REPORT	Perform detailed analyses of the content of the recovery catalog.
RESET DATABASE	Inform RMAN that the SQL statement <code>ALTER DATABASE OPEN RESETLOGS</code> has been executed and that a new incarnation of the target database has been created, or reset the target database to a prior incarnation.
RESTORE	Restore files from backup sets or from disk copies to the default or a new location.
RESYNC CATALOG	Perform a full resynchronization, which creates a snapshot control file and then copies any new or changed information from that snapshot control file to the recovery catalog.
REVOKE	Revoke privileges from a recovery catalog user.
RMAN	Start RMAN from the operating system command line.

Table 1-1 (Cont.) Recovery Manager Commands

Command	Purpose
<a href="#">RUN</a>	Execute a sequence of one or more RMAN commands, which are one or more statements executed within the braces of <code>RUN</code> .
<a href="#">SEND</a>	Send a vendor-specific quoted string to one or more specific channels.
<a href="#">SET</a>	Set the value of various attributes that affect RMAN behavior for the duration of a <code>RUN</code> block or a session.
<a href="#">SHOW</a>	Display the current <code>CONFIGURE</code> settings.
<a href="#">SHUTDOWN</a>	Shut down the target database. This command is equivalent to the SQL*Plus <code>SHUTDOWN</code> command.
<a href="#">SPOOL</a>	Write RMAN output to a log file.
<a href="#">SQL</a>	Execute a SQL statement or PL/SQL procedures from within Recovery Manager.
<a href="#">SQL (Quoted)</a>	Execute a SQL statement from within Recovery Manager. See the <code>SQL</code> command for improved syntax.
<a href="#">STARTUP</a>	Start the target database. This command is equivalent to the SQL*Plus <code>STARTUP</code> command.
<a href="#">SWITCH</a>	Specify that a data file copy is now the <b>current data file</b> , that is, the data file pointed to by the control file.
<a href="#">TRANSPORT TABLESPACE</a>	Create transportable tablespace sets from backup for one or more tablespaces.
<a href="#">UNREGISTER</a>	Unregister a database from the recovery catalog.
<a href="#">UPGRADE CATALOG</a>	Upgrade the recovery catalog schema from an older version to the version required by the RMAN executable.
<a href="#">VALIDATE</a>	Examine a backup set and report whether its data is intact. RMAN scans all of the backup pieces in the specified backup sets and looks at the checksums to verify that the contents can be successfully restored.

## 1.5 Summary of RMAN Subclauses

RMAN subclauses are used in multiple commands.

Subclauses are documented in a separate chapter to avoid unnecessary duplication. The descriptions of commands that use these subclauses include a cross-reference to the subclause entry in [RMAN Subclauses](#). [Table 1-2](#) summarizes the RMAN subclauses.

Table 1-2 Recovery Manager Subclauses

Subclause	Specifies . . .
<a href="#">allocOperandList</a>	Channel control options such as <code>PARMS</code> and <code>FORMAT</code>
<a href="#">archivelogRecordSpecifier</a>	A range of archived redo log files
<a href="#">completedTimeSpec</a>	A time range during which the backup or copy completed
<a href="#">connectStringSpec</a>	The user name, password, and net service name for connecting to a target, recovery catalog, or auxiliary database. The connection is necessary to authenticate the user and identify the database



**Table 1-2 (Cont.) Recovery Manager Subclauses**

Subclause	Specifies . . .
<a href="#">datafileSpec</a>	A data file by file name or absolute file number
<a href="#">dbObject</a>	A database or part of a database.
<a href="#">deviceSpecifier</a>	The type of storage device for a backup or copy
<a href="#">fileNameConversionSpec</a>	Patterns to transform source to target file names during <code>BACKUP AS COPY</code> , <code>CONVERT</code> and <code>DUPLICATE</code>
<a href="#">forDbUniqueNameOption</a>	All databases in a Data Guard environment or a database with the specified <code>DB_UNIQUE_NAME</code>
<a href="#">foreignFileSpec</a>	Names of database objects to be recovered and the backup sets that contain these objects
<a href="#">foreignlogRecordSpecifier</a>	A range of foreign archived redo log files
<a href="#">formatSpec</a>	A file name format for a backup or copy
<a href="#">keepOption</a>	A backup or copy is or is not exempt from the current retention policy
<a href="#">listObjList</a>	Items to be displayed by the <code>LIST</code> command
<a href="#">maintQualifier</a>	Additional options for maintenance commands such as <code>DELETE</code> and <code>CHANGE</code>
<a href="#">maintSpec</a>	Files operated on by maintenance commands such as <code>CHANGE</code> , <code>CROSSCHECK</code> , and <code>DELETE</code>
<a href="#">obsOperandList</a>	Backups that are obsolete according to specified criteria
<a href="#">recordSpec</a>	Objects that the maintenance commands operate on
<a href="#">sizeSpec</a>	Size of the data
<a href="#">tempfileSpec</a>	A temp file by path or by file number
<a href="#">untilClause</a>	An upper limit by time, SCN, or log sequence number. This clause is usually used to specify the desired point in time for an incomplete recovery

# 2

## RMAN Commands: @ (at sign) to QUIT

This chapter describes RMAN commands in alphabetical order. For a summary of the RMAN commands and command-line options, refer to "[Summary of RMAN Commands](#)".

- @ (at sign)
- @@ (double at sign)
- ADVISE FAILURE
- ALLOCATE CHANNEL
- ALLOCATE CHANNEL FOR MAINTENANCE
- BACKUP
- CATALOG
- CHANGE
- CONFIGURE
- CONNECT
- CONVERT
- CREATE CATALOG
- CREATE SCRIPT
- CROSSCHECK
- DELETE
- DELETE SCRIPT
- DESCRIBE
- DROP CATALOG
- DROP DATABASE
- DUPLICATE
- EXECUTE SCRIPT
- EXIT
- FLASHBACK DATABASE
- GRANT
- HOST
- IMPORT CATALOG
- LIST
- PRINT SCRIPT
- QUIT

 **Note:**

A multitenant container database is the only supported architecture in Oracle Database 21c. While the documentation is being revised, legacy terminology may persist. In most cases, "database" and "non-CDB" refer to a CDB or PDB, depending on context. In some contexts, such as upgrades, "non-CDB" refers to a non-CDB from a previous release.

## 2.1 @ (at sign)

### Purpose

Use the @ command to execute a series of RMAN commands stored in an operating system file with the specified path name.

 **Note:**

The file must contain complete RMAN commands. Partial commands generate syntax errors.

### Prerequisites

The command file must contain complete RMAN commands.

If you use the @ command within a [RUN](#) command, then the @ command must be on its own line (see [Example 2-2](#)).

### Usage Notes

RMAN processes the file as though its contents were entered instead of the @ command. As shown in [Example 2-3](#), you can specify substitution variables in a command file and then pass values to the command file during execution.

 **See Also:**

[RMAN](#) to learn more about using substitution variables in RMAN

### Syntax

@::=

→ @ filename →

## Semantics

Syntax Element	Description
<i>filename</i>	Specifies the name of a command file, for example, <code>@/oracle/dbs/cmd/cmd1.rman</code> . If you do not specify the absolute path name, then the current working directory is assumed, for example, <code>@cmd1.rman</code> .  Any file extension (or no file extension) is valid. Do not use quotes around the string or leave whitespace between the <code>@</code> keyword and the file name.

### Examples

#### Example 2-1 Running a Command File from the Operating System Command Line

This example creates an RMAN command file and then executes it from the operating system command line.

```
% echo "BACKUP DATABASE;" > backup_db.rman
% rman TARGET / @backup_db.rman
```

#### Example 2-2 Running a Command File Within RMAN

This example shows how you can execute a command file from the RMAN prompt and from within a `RUN` command. User-entered text appears in bold.

```
RMAN> @backup_db.rman
RMAN> RUN {
2> @backup_db.rman
3> backup database;
4> **end-of-file**
5> }
```

#### Example 2-3 Specifying Substitution Variables

Suppose that you use a text editor to create command file `whole_db.rman` with the following contents:

```
# name: whole_db.rman
BACKUP TAG &1 COPIES &2 DATABASE;
EXIT;
```

The following example starts RMAN from the operating system prompt and connects to the target database. The example then runs the `@` command, passing variables to the command file to create two database backups with tag `Q106`:

```
% rman TARGET /
RMAN> @/tmp/whole_db.rman Q106 2
```

## 2.2 @@ (double at sign)

### Purpose

Use the `@@` command to execute a series of RMAN commands stored in an operating system file with the specified file name.

If @@ is contained in a command file, then @@*filename* directs RMAN to look for the specified file name in the same directory as the command file from which it was called. If not used within a command file, the @@ command is identical to the @ (at sign) command.

### Prerequisites

The command file must contain complete RMAN commands.

### Usage Notes

The command file is local to the RMAN client. The name resolution of the file is dependent on the operating system. For example, @tmp/cmd1.rman in UNIX or Windows means that tmp is a subdirectory of the current directory and that the file cmd1.rman is in this subdirectory.

To illustrate the differences between the @ and @@ commands, assume that you invoke RMAN as follows:

```
% rman TARGET /
RMAN> @/tmp/cmd1.rman
```

Assume that the command @@cmd2.rman appears inside the cmd1.rman script. In this case, the @@ command directs RMAN to search for the file cmd2.rman in the directory /tmp.

As with the @ command, you can specify substitution variables in a command file and then pass values to the command file during execution of @@ (see [Example 2-4](#)).

### Syntax

@@::=

→ @@ → filename →

### Semantics

Syntax Element	Description
<i>filename</i>	Specifies the name of a command file, for example, @@cmd2.rman.

### Example

#### Example 2-4 Calling a Command File Within Another Command File

The following operating system commands create command files backup\_logs.rman and backup\_db.rman:

```
% echo "BACKUP ARCHIVELOG ALL;" > /tmp/bkup_logs.rman
% echo "BACKUP TAG &1 DATABASE;" > /tmp/bkup_db.rman
% echo "@@bkup_logs.rman" >> /tmp/bkup_db.rman
```

The following example starts RMAN from the command line and connects to the target database with operating system authentication. The @ command executes bkup\_db.rman, which contains the command @@bkup\_logs.rman. The @@ command looks for the bkup\_logs.rman script in the same directory in which bkup\_db.rman is

located. The example uses a substitution variable to specify the tag `WHOLE_DB` for the database backup.

```
% rman TARGET /  
RMAN> @/tmp/bkup_db.rman whole_db
```

## 2.3 ADVISE FAILURE

### Purpose

Use the `ADVISE FAILURE` command to display repair options for the specified failures. This command prints a summary of the failures identified by the Data Recovery Advisor and implicitly closes all open failures that are fixed.

The recommended workflow is to run the following commands in an RMAN session: `LIST FAILURE` to display failures, `ADVISE FAILURE` to display repair options, and `REPAIR FAILURE` to fix the failures.

Starting in Oracle Database 19c, the Data Recovery Advisor (DRA) feature is deprecated.

The deprecation of DRA includes deprecation of the following Oracle Recovery Manager (RMAN) commands: `LIST FAILURE`, `ADVISE FAILURE`, `REPAIR FAILURE`, and `CHANGE FAILURE`. Database administrators will no longer have access to these commands. There is no replacement feature for DRA.

### Prerequisites

RMAN must be connected to a target database. See the `CONNECT` and `RMAN` commands to learn how to connect to a database as `TARGET`.

The target database instance must be started. The target database must be a single-instance database and must not be a physical standby database, although it can be a logical standby database.

In the current release, Data Recovery Advisor only supports single-instance databases. Oracle Real Application Clusters (Oracle RAC) databases are not supported.

### Usage Notes

Data Recovery Advisor verifies repair feasibility before proposing a repair strategy. For example, Data Recovery Advisor checks that all backups and archived redo log files needed for media recovery are available. The `ADVISE FAILURE` output indicates the repair strategy that Data Recovery Advisor considers optimal for a given set of failures. The `ADVISE FAILURE` command can generate both manual and automated repair options.

### Manual Repair Options

Manual repair options are either mandatory or optional. The optional actions may fix the failures more quickly or easily than automated repairs. For example, Data Recovery Advisor may recommend a failover to a standby database as an alternative to a primary database repair.

In other cases, the only options are manual because automated repairs are not feasible. For example, I/O failures often cannot be repaired automatically. Also, it is sometimes impossible to diagnose a failure because insufficient data is returned by the operating system or the disk subsystem.

### Automated Repair Options

Each automated repair option is either a single repair or a set of repair steps (see [Table 2-1](#) for a description of command output). When a repair option has a script that contains multiple repair steps, `ADVISE FAILURE` generates the script so that the repair steps are in the correct order. A single repair always fixes critical failures together. You must repair critical failures, but you can also repair noncritical failures at the same time. You can repair noncritical failures in a random order, one by one, or in groups.

### Oracle RAC and Data Recovery Advisor

If a data failure brings down all instances of an Oracle RAC database, then you can mount the database in single-instance mode and use Data Recovery Advisor to detect and repair control file, `SYSTEM` data file, and dictionary failures. You can also initiate health checks to test other database components for data failures. This approach does not detect data failures that are local to other cluster instances, for example, an inaccessible data file.

### Syntax

**`advise::=`**

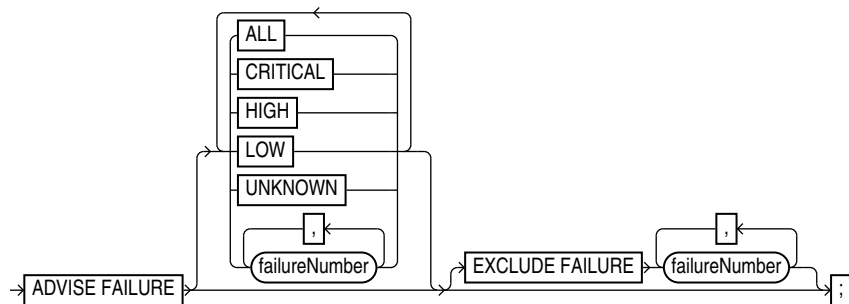

### Semantics

**`advise`**

Syntax Element	Description
<code>ADVISE FAILURE</code>	Displays information for all <code>CRITICAL</code> and <code>HIGH</code> priority failures recorded in the automatic diagnostic repository. You can only use <code>ADVISE FAILURE</code> with no options when a <code>LIST FAILURE</code> command was previously executed in the current session. <b>Note:</b> If a new failure has been recorded in the diagnostic repository since the last <code>LIST FAILURE</code> command in the current RMAN session, then RMAN issues a warning before advising on <code>CRITICAL</code> and <code>HIGH</code> failures.
<code>ALL</code>	Lists options that repair all open failures together.
<code>CRITICAL</code>	Lists options that repair only critical failures.
<code>HIGH</code>	Lists options that repair only failures with <code>HIGH</code> priority.
<code>LOW</code>	Lists options that repair only failures with <code>LOW</code> priority.
<code>UNKNOWN</code>	Lists options that repair only failures whose priority cannot be determined until the database is mounted.
<code>failureNumber</code>	Lists options that repair only the specified failures.

Syntax Element	Description
EXCLUDE FAILURE <i>failureNumber</i>	Excludes the specified failures from the list.

### ADVISE FAILURE Command Output

The ADVISE FAILURE output includes the LIST FAILURE output, which is described in Table 2-27. See Example 2-5 for sample output.

RMAN presents mandatory and optional manual actions in an unordered list. If manual options exist, then they appear before automated options. Table 2-1 describes the output for automated repair options.

**Table 2-1 Automated Repair Options**

Column	Indicates
Option	The identifier for the automated repair option.
Strategy	A strategy to fix the failure with the REPAIR FAILURE command. The Data Recovery Advisor always presents an automated repair option with no data loss when possible. Automated repair options fall into the following basic categories: <ul style="list-style-type: none"> <li>Repair with no data loss</li> <li>Repair with data loss, for example, Flashback Database</li> </ul> <b>Note:</b> The ADVISE command maps a set of failures to the set of repair steps that Data Recovery Advisor considers to be optimal. When possible, Data Recovery Advisor consolidates multiple repair steps into a single repair. For example, if the database has corrupted data file, missing control file, and lost current redo log group, then Data Recovery Advisor would recommend a single, consolidated repair plan to restore the database and perform point-in-time recovery.
Repair Description	A description of the proposed repair. For example, the proposed repair could be to restore and recover data file 17.
Repair Script	The location of an editable script with all repair actions and comments. If you do not choose an automated repair, then you can review this script and edit it for use in a manual recovery strategy.

### Examples

#### Example 2-5 Displaying Repair Options for All Failures

This example shows repair options for all failures known to the Recovery Data Advisor. The example indicates two failures: missing data files and a data file with corrupt blocks.

```
RMAN> LIST FAILURE;
```

```
List of Database Failures
=====
```

```
Failure ID Priority Status Time Detected Summary
-----
```

142	HIGH	OPEN	23-APR-13	One or more non-system datafiles are missing
101	HIGH	OPEN	23-APR-13	Datafile 1: '/disk1/oradata/prod/system01.dbf' contains one or more corrupt blocks

```
RMAN> ADVISE FAILURE;
```

```
List of Database Failures
=====
```



```

Failure ID Priority Status Time Detected Summary
-----
142 HIGH OPEN 23-APR-13 One or more non-system datafiles
are missing
101 HIGH OPEN 23-APR-13 Datafile 1: '/disk1/oradata/prod/system01.dbf'
contains one or more corrupt blocks

analyzing automatic repair options; this may take some time
using channel ORA_DISK_1
analyzing automatic repair options complete

Mandatory Manual Actions
=====
no manual actions available

Optional Manual Actions
=====
1. If file /disk1/oradata/prod/users01.dbf was unintentionally renamed or moved, restore it

Automated Repair Options
=====
Option Repair Description
-----
1 Restore and recover datafile 28; Perform block media recovery of
block 56416 in file 1
Strategy: The repair includes complete media recovery with no data loss
Repair script: /disk1/oracle/log/diag/rdbms/prod/prod/hm/reco_660500184.hm

```

## 2.4 ALLOCATE CHANNEL

### Purpose

`ALLOCATE CHANNEL` manually allocates a **channel**, which is a connection between RMAN and a database instance. The `ALLOCATE CHANNEL` command must be issued within a `RUN` block. It allocates a channel only in the block where the command is issued.

### Prerequisites

The target instance must be started.

### Usage Notes

Manually allocated channels are distinct from automatically allocated channels specified with `CONFIGURE`. Automatic channels apply to any RMAN job in which you do *not* manually allocate channels. You can override automatic channel configurations by manually allocating channels within a `RUN` command, but you cannot use `BACKUP DEVICE TYPE` or `RESTORE DEVICE TYPE` to use automatic channels after specifying manual channels with `ALLOCATE CHANNEL`.

### Multiple Channels

You can allocate up to 255 channels; each channel can read up to 64 files in parallel. You can control the degree of parallelism within a job by the number of channels that you allocate. Allocating multiple channels simultaneously allows a single job to read or write multiple backup sets or disk copies in parallel, with each channel operating on a separate backup set or copy.

When making backups to disk, the guideline is to allocate one channel for each output device (see [Example 2-7](#)). If RMAN is writing to a striped file system or an ASM disk

group, however, then multiple channels can improve performance. When backing up to tape, the guideline is that the number of tape channels equals the number of tape devices divided by the number of duplexed copies (see [Example 2-8](#)).

### Channels in an Oracle RAC Environment

If the password for the `SYS` and `SYSBACKUP` users all Oracle RAC instances is the same, then you do not need to put passwords in the `CONNECT` option of the `ALLOCATE` or `CONFIGURE` command. If you use a connect string of the form `user@database`, then RMAN automatically uses the same password that was used for the `TARGET` connection when the RMAN session was started.

### Syntax

**allocate::=**

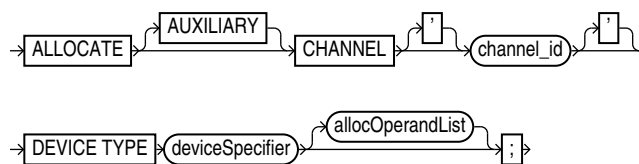

([deviceSpecifier::=](#), [allocOperandList::=](#))

### Semantics

Syntax Element	Description
AUXILIARY	<p>Specifies a connection between RMAN and an auxiliary database instance. An auxiliary instance is used when executing the <a href="#">DUPLICATE</a> or <a href="#">TRANSPORT TABLESPACE</a> command, and when performing TSPITR with <a href="#">RECOVER TABLESPACE</a> (see <a href="#">Example 2-9</a>). When specifying this option, the auxiliary instance must be started but not mounted.</p> <p><b>See Also:</b> <a href="#">DUPLICATE</a> to learn how to duplicate a database, and <a href="#">CONNECT</a> to learn how to connect to a duplicate database instance</p>
CHANNEL <i>channel_id</i>	<p>Specifies a connection between RMAN and the target database instance. The <i>channel_id</i> is the case-sensitive name of the channel. The database uses the <i>channel_id</i> to report I/O errors.</p> <p>Each connection initiates a database server session on the target or auxiliary instance: this session performs the work of backing up, restoring, or recovering RMAN backups. You cannot make a connection to a shared server session.</p> <p>Whether <code>ALLOCATE CHANNEL</code> allocates operating system resources immediately depends on the operating system. On some platforms, operating system resources are allocated at the time the command is issued. On other platforms, operating system resources are not allocated until you open a file for reading or writing.</p> <p>Each channel operates on one backup set or image copy at a time. RMAN automatically releases the channel at the end of the job.</p> <p><b>Note:</b> You cannot prefix <code>ORA_</code> to a channel name. RMAN reserves channel names beginning with the <code>ORA_</code> prefix for its own use.</p>

Syntax Element	Description
DEVICE TYPE <a href="#">deviceSpecifier</a>	Specifies the type of storage for a backup. Query the V\$BACKUP_DEVICE view for information about available device types and names. <b>Note:</b> When you specify DEVICE TYPE DISK, no operating system resources are allocated other than for the creation of the server session. <b>See Also:</b> <a href="#">deviceSpecifier</a>
<a href="#">allocOperandList</a>	Specifies control options for the allocated channel. The channel parameters for sequential I/O devices are platform-specific (see <a href="#">Example 2-6</a> ). <b>See Also:</b> <a href="#">allocOperandList</a>

## Examples

### Example 2-6 Manually Allocating a Channel for a Backup

This example allocates a single tape channel for a whole database and archived redo log backup. The PARMS parameter specifies the Oracle Secure Backup media family named wholedb\_mf.

```
RUN
{
  ALLOCATE CHANNEL c1 DEVICE TYPE sbt
    PARMS 'ENV=(OB_MEDIA_FAMILY=wholedb_mf)';
  BACKUP DATABASE;
  BACKUP ARCHIVELOG ALL NOT BACKED UP;
}
```

### Example 2-7 Distributing a Backup Across Multiple Disks

When backing up to disk, you can spread the backup across several disk drives. Allocate one DEVICE TYPE DISK channel for each disk drive and specify the format string so that the output files are on different disks.

```
RUN
{
  ALLOCATE CHANNEL disk1 DEVICE TYPE DISK FORMAT '/disk1/%U';
  ALLOCATE CHANNEL disk2 DEVICE TYPE DISK FORMAT '/disk2/%U';
  BACKUP DATABASE PLUS ARCHIVELOG;
}
```

### Example 2-8 Creating Multiple Copies of a Backup on Tape

In this example, four tape drives are available for writing: stape1, stape2, stape3, and stape4. You use the SET BACKUP COPIES command to instruct RMAN to create two identical copies of the database backup. Because the guideline is that the number of tape channels equals the number of tape devices divided by the number of duplexed copies, you allocate two channels. In this case the BACKUP\_TAPE\_IO\_SLAVES initialization parameter must be set to TRUE.

In the OB\_DEVICE\_n parameter for Oracle Secure Backup, the n specifies the copy number of the backup piece. RMAN writes copy 1 of each backup piece to tape drives stape1 and stape2 and writes copy 2 of each backup piece to drives stape3 and stape4. Thus, each copy of the database backup is distributed between two tape drives, so that part of the data is on each drive.

```
RUN
{
```

```

ALLOCATE CHANNEL t1 DEVICE TYPE sbt
  PARMS 'ENV=(OB_DEVICE_1=stape1,OB_DEVICE_2=stape3)';
ALLOCATE CHANNEL t2 DEVICE TYPE sbt
  PARMS 'ENV=(OB_DEVICE_1=stape2,OB_DEVICE_2=stape4)';
SET BACKUP COPIES 2;
BACKUP DATABASE;
}

```

### Example 2-9 Allocating an Auxiliary Channel for Database Duplication

This example creates a duplicate database from backups. RMAN can use configured channels for duplication even if they do not specify the `AUXILIARY` option. In this example, no SBT channel is preconfigured, so an auxiliary SBT channel is manually allocated.

```

RUN
{
  ALLOCATE AUXILIARY CHANNEL c1 DEVICE TYPE sbt;
  DUPLICATE TARGET DATABASE
    TO dupdb
  DB_FILE_NAME_CONVERT '/disk2/dbs/', '/disk1/'
  SPFILE
    PARAMETER_VALUE_CONVERT '/disk2/dbs/',
                             '/disk1/'
  SET LOG_FILE_NAME_CONVERT '/disk2/dbs/',
                             '/disk1/';
}

```

#### See Also:

*Oracle Database Reference* for more information on the parameter `DB_FILE_NAME_CONVERT`

## 2.5 ALLOCATE CHANNEL FOR MAINTENANCE

### Purpose

Use the `ALLOCATE CHANNEL FOR MAINTENANCE` command to manually allocate a channel in preparation for issuing a `CHANGE`, `DELETE`, or `CROSSCHECK` command. You can use the `RELEASE CHANNEL` command to unallocate the channel.

#### Note:

If you `CONFIGURE` at least one channel for each device type in your configuration, then you do not need to use `ALLOCATE CHANNEL FOR MAINTENANCE`. Oracle recommends that you use configured channels instead of maintenance channels. You can use configured channels for all RMAN I/O to the specified device, not just the maintenance tasks supported by maintenance channels. The configured channels persist across RMAN sessions.

## Prerequisites

Execute this command only at the RMAN prompt, not within a `RUN` block. The target instance must be started. You cannot allocate a maintenance channel to a shared session.

## Usage Notes

As a rule, allocate one maintenance channel for each device. Manually allocated channels and automatic channels are never mixed. In general, allocate multiple maintenance channels for a single job only in these situations:

- To enable cross-checking or deletion of all backup pieces both on disk and tape, with a single command (see [Example 2-11](#))
- To make cross-checking and deleting work correctly in an Oracle Real Application Clusters (Oracle RAC) configuration in which each backup piece exists only on one node (see [Example 2-12](#))

RMAN uses the following convention for naming of maintenance channels:

`ORA_MAINT_devicetype_n`, where *devicetype* refers to `DISK` or `sbt` and *n* refers to the channel number. For example, RMAN uses these names for two manually allocated disk channels:

```
ORA_MAINT_DISK_1
ORA_MAINT_DISK_2
```



### See Also:

*Oracle Database Backup and Recovery User's Guide* to learn how to cross-check and delete on multiple channels

## Syntax

***allocateForMaint::=***

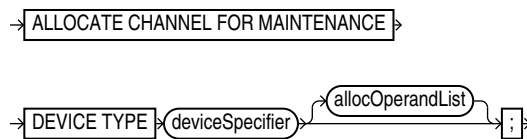

([deviceSpecifier::=](#), [allocOperandList::=](#))

## Semantics

***allocateForMaint***

Syntax Element	Description
DEVICE TYPE <a href="#">deviceSpecifier</a>	Specifies the type of storage for a backup. Query the V\$BACKUP_DEVICE view for information about available device types and names. <b>See Also:</b> <a href="#">deviceSpecifier</a>
<a href="#">allocOperandList</a>	Specifies control options for the allocated channel. The channel parameters for sequential I/O devices are platform-specific. <b>See Also:</b> <a href="#">allocOperandList</a>

## Examples

### Example 2-10 Deleting Backup Sets

Assume that you want to recycle a set of tapes by deleting all RMAN backups. In this example, only a disk channel is configured by default. The example manually allocates an SBT channel, deletes all backups from tape, and then releases the channel.

```

RMAN> ALLOCATE CHANNEL FOR MAINTENANCE DEVICE TYPE sbt;

```

```

allocated channel: ORA_MAINT_SBT_TAPE_1
channel ORA_MAINT_SBT_TAPE_1: SID=135 device type=SBT_TAPE
channel ORA_MAINT_SBT_TAPE_1: Oracle Secure Backup

```

```

RMAN> DELETE NOPROMPT BACKUP;

```

List of Backup Pieces

BP Key	BS Key	Pc#	Cp#	Status	Device Type	Piece Name
9957	9954	1	1	AVAILABLE	SBT_TAPE	8oic41ad_1_1
9974	9972	1	1	AVAILABLE	SBT_TAPE	c-28014364-20130308-17
10024	10021	1	1	AVAILABLE	SBT_TAPE	8qic41c3_1_1
10045	10042	1	1	AVAILABLE	SBT_TAPE	c-28014364-20130308-18
10446	10443	1	1	AVAILABLE	SBT_TAPE	8uic47fg_1_1
10487	10482	1	1	AVAILABLE	SBT_TAPE	90ic47ih_1_1
10488	10483	1	1	AVAILABLE	SBT_TAPE	91ic47j1_1_1
10524	10514	1	1	AVAILABLE	SBT_TAPE	92ic47q4_1_1
10540	10538	1	1	AVAILABLE	SBT_TAPE	c-28014364-20130308-1a

```

deleted backup piece
backup piece handle=8oic41ad_1_1 RECID=198 STAMP=616695118
deleted backup piece
backup piece handle=c-28014364-20130308-17 RECID=199 STAMP=616695145
deleted backup piece
backup piece handle=8qic41c3_1_1 RECID=200 STAMP=616695171
deleted backup piece
backup piece handle=c-28014364-20130308-18 RECID=201 STAMP=616695188
deleted backup piece
backup piece handle=8uic47fg_1_1 RECID=204 STAMP=616701424
deleted backup piece
backup piece handle=90ic47ih_1_1 RECID=205 STAMP=616701521
deleted backup piece
backup piece handle=91ic47j1_1_1 RECID=206 STAMP=616701538
deleted backup piece
backup piece handle=92ic47q4_1_1 RECID=207 STAMP=616701764
deleted backup piece
backup piece handle=c-28014364-20130308-1a RECID=208 STAMP=616701783
Deleted 11 objects

```

```

RMAN> RELEASE CHANNEL;

```

```
released channel: ORA_MAINT_SBT_TAPE_1
```

### Example 2-11 Cross-Checking Backups on Multiple Devices

Assume that you want to cross-check backups of archived redo log files on disk and tape. Assume also that you have the default device type configured to disk, and also have an SBT channel configured, but you want to use different channel settings for both disk and tape. In this case, you can manually allocate maintenance channels with the desired settings.

```
RMAN> SHOW DEFAULT DEVICE TYPE;

RMAN configuration parameters for database with db_unique_name PROD are:
CONFIGURE DEFAULT DEVICE TYPE TO DISK;

RMAN> SHOW CHANNEL;

RMAN configuration parameters for database with db_unique_name PROD are:
CONFIGURE CHANNEL DEVICE TYPE 'SBT_TAPE' PARMS 'SBT_LIBRARY=/usr/local/oracle/
backup/lib/libobk.so, ENV=(OB_DEVICE_1=stapel)';

RMAN> ALLOCATE CHANNEL FOR MAINTENANCE DEVICE TYPE sbt PARMS 'SBT_LIBRARY=/usr/
local/oracle/backup/lib/libobk.so, ENV=(OB_DEVICE_1=stape2)';

allocated channel: ORA_MAINT_SBT_TAPE_1
channel ORA_MAINT_SBT_TAPE_1: SID=135 device type=SBT_TAPE
channel ORA_MAINT_SBT_TAPE_1: Oracle Secure Backup

RMAN> ALLOCATE CHANNEL FOR MAINTENANCE DEVICE TYPE DISK FORMAT "/disk2/%U";

allocated channel: ORA_MAINT_DISK_2
channel ORA_MAINT_DISK_2: SID=101 device type=DISK

Finished Control File and SPFILE Autobackup at 09-MAR-13

RMAN> CROSSCHECK BACKUP OF ARCHIVELOG ALL;

crosschecked backup piece: found to be 'AVAILABLE'
backup piece handle=/disk2/95ic69jc_1_1 RECID=210 STAMP=616769132
crosschecked backup piece: found to be 'EXPIRED'
backup piece handle=/disk2/96ic69jf_1_1 RECID=211 STAMP=616769135
Crosschecked 2 objects

crosschecked backup piece: found to be 'AVAILABLE'
backup piece handle=/disk2/96ic69jf_1_1 RECID=211 STAMP=616769135
Crosschecked 1 objects

RMAN> RELEASE CHANNEL;

released channel: ORA_MAINT_SBT_TAPE_1
released channel: ORA_MAINT_DISK_2
```

### Example 2-12 Cross-Checking in an Oracle Real Application Clusters (Oracle RAC) Configuration

All nodes in an Oracle RAC configuration should have the same access to all backups on all storage devices, but this is not a requirement. Assume that you want to cross-check backups on two nodes of an Oracle RAC configuration, where each node has access to a subset of disk backups. It is assumed that all backups are accessible by at

least a two nodes used in the cross-check. Any backup not accessible from at least one node is marked `EXPIRED` after the cross-check.

The following example illustrates channel connections to Oracle RAC instances `inst1` and `inst2`. For both channel connections, RMAN uses the same user name and password that were entered for the target database connection.

```
ALLOCATE CHANNEL FOR MAINTENANCE DEVICE TYPE DISK
  CONNECT '@inst1';
ALLOCATE CHANNEL FOR MAINTENANCE DEVICE TYPE DISK
  CONNECT '@inst2';
CROSSCHECK BACKUP;
```

## 2.6 BACKUP

### Purpose

Use the `BACKUP` command to back up a primary or standby database, the root, one or more pluggable databases (PDBs), tablespace, data file (current or copy), control file (current or copy), server parameter file, archived redo log file, or backup set.

### Additional Topics

- [Prerequisites](#)
- [Usage Notes](#)
- [Syntax](#)
- [Semantics](#)
- [Examples](#)

### Prerequisites

RMAN must be connected to a target database. See the [CONNECT](#) and [RMAN](#) commands to learn how to connect to a database as `TARGET`.

### Database Archiving Modes

If the target database is in `ARCHIVELOG` mode, then the database must be mounted or open with a current control file. Backups made while the database is open are inconsistent. You must apply redo log files after restoring an inconsistent backup to make the database consistent.

If the target database is in `NOARCHIVELOG` mode, then the database must be mounted after a consistent shutdown when you make the backup. The shutdown is only consistent if you successfully execute the `SHUTDOWN` command with the `NORMAL`, `IMMEDIATE`, or `TRANSACTIONAL` options. You cannot use RMAN to back up a `NOARCHIVELOG` database after an instance failure or `SHUTDOWN ABORT`.

### Encrypted Backups

To create encrypted backups using a password-based software keystore, you must have the `SYSCONNECT` and `SYSKM` privileges. The `SYSKM` privilege is required to .

### Backing Up Data for Cross-Platform Transport

To create backup sets that transport data to another platform, the `COMPATIBLE` parameter in the target database must be 12.0.0 or higher.



To back up the entire database for cross-platform transport, the source and destination platform must use the same endian format. The source database must be open in read-only mode.

While backing up tablespaces for cross-platform transport, if the `ALLOW INCONSISTENT` clause is not used, the tablespaces must be in read-only mode.

### Preplugin Backups

- The `COMPATIBLE` initialization parameter must be set to 18.0.0 or higher on both the source and destination CDB.
- The source database must be in `ARCHIVELOG` mode.
- The source database must be in read-write mode.
- The backup location containing the preplugin backups must be accessible to the destination database.

### Backup Media

RMAN can only back up files onto valid media. If you specify `DEVICE TYPE DISK`, then RMAN makes backups to random access disks. You can make a backup on any device that can store a data file. If the statement `CREATE TABLESPACE tablespace_name DATAFILE 'filename'` works, then `'filename'` is a valid backup path name. If you specify `DEVICE TYPE sbt`, then you can back up files to any media supported by the media manager.

When backing up Oracle Database files to disk, the logical block size of the files must be an even multiple of the physical block size of the destination device. For example, a disk device with a block size of 2 KB can only be used as a destination for backups of Oracle files with logical block sizes of 2 KB, 4 KB, 6 KB and so on. In practice, most disk drives have physical block sizes of 512 bytes, so this limitation rarely affects backup. However, you can encounter this limitation when using `BACKUP ... DEVICE TYPE DISK` to back your database up to a writeable CD or DVD, or some other device that has a larger physical block size.

### Channels

If no automatic channel is configured for the specified device type, then you must manually allocate a channel for each `BACKUP` execution. If no manual channel is allocated, then RMAN uses the default channels set with the `CONFIGURE` command. RMAN has a `DISK` channel preconfigured but no preconfigured `sbt` channels.

#### Note:

Backups that use the disk test API are not supported for production backups. Instead, use the preconfigured `DISK` channel or manually allocate a `DISK` channel.

### Usage Notes

RMAN can only back up data files, control files, server parameter files, archived redo log files, and RMAN backups of these files. RMAN cannot make backups of other database-related files such as network configuration files, password files, the block change tracking file, and the contents of the Oracle home directory. Likewise, some

features of Oracle Database, such as external tables or the `BFILE` data type, store data in files other than those in the preceding list. RMAN cannot back up these files.

RMAN decomposes a `BACKUP` command into multiple independent backup steps. RMAN can execute each independent step on any channel allocated for a specific device. If multiple channels are allocated, and if one channel fails or encounters a problem during a backup step, then RMAN attempts to complete the work on another channel. RMAN reports a message in `V$RMAN_OUTPUT` and in the output to the interactive session or log file when channel failover occurs.

RMAN backups made on one platform can be transported to a different platform only if you use either the `FOR TRANSPORT` or `TO PLATFORM` clause while creating the backup.

RMAN backups made in a previous release of Oracle Database are usable after a database migration or upgrade. See My Oracle Support Note 790559.1 at <https://support.oracle.com/rs?type=doc&id=790559.1> for information about this procedure.

If you change the `DB_NAME` for a database, but not its `DBID`, then RMAN considers backups made of the database with the previous `DB_NAME` as eligible to be restored.

### Incremental Backups

An `INCREMENTAL` backup at level 0 backs up all data blocks in data files being backed up. An incremental backup at level 0 is identical in content to a `FULL` backup, but unlike a full backup the level 0 backup is a part of the incremental backup strategy.

A level 1 backup copies only changed blocks. A level 1 incremental backup is either differential or `CUMULATIVE`. If cumulative, RMAN backs up all blocks changed since the most recent level 0 backup. If differential, RMAN backs up blocks updated since the most recent level 0 or level 1 incremental backup. You can apply a level 1 backup of a standby database to a level 0 backup of a primary database, and also apply a level 1 backup of a primary database to a level 0 backup of a standby database.

Incremental backups at level 0 can be either backup sets or image copies, but incremental backups at level 1 can only be backup sets.

The database performs checks when attempting to create a level 1 incremental backup to ensure that the incremental backup is usable by a subsequent `RECOVER` command. Among the checks performed are:

- A level 0 backup must exist for each data file in the `BACKUP` command as the base backup for an incremental strategy. Level 0 backups must not have status `UNAVAILABLE`. If no level 0 backup exists, then RMAN makes a level 0 backup automatically.
- Sufficient incremental backups taken since level 0 must exist and be available such that the incremental backup to be created is usable.

#### Note:

When creating an incremental backup, RMAN considers backups from parent incarnations as valid. For example, assume you make a level 0 backup and then `OPEN RESETLOGS`. If you make a level 1 incremental backup, then RMAN backs up all blocks changed since the `pre-RESETLOGS` level 0 backup. When making a level 1 backup, RMAN only makes a new level 0 backup if no level 0 is available in either the current or parent database incarnation.

You can improve incremental backup performance by enabling **block change tracking** on a primary or standby database. In this case, RMAN keeps a record of which blocks have changed in the block change tracking file.

The change tracking file maintains bitmaps that mark changes in the data files between backups. The database performs a bitmap switch before each backup. Oracle Database automatically manages space in the change tracking file to retain block change data that covers the 8 most recent backups. After the maximum of 8 bitmaps is reached, the most recent bitmap is overwritten by the bitmap that tracks the current changes.

The first level 0 incremental backup scans the entire data file. Subsequent incremental backups use the block change tracking file to scan only the blocks that have been marked as changed since the last backup. An incremental backup can be optimized only when it is based on a parent backup that was made after the start of the oldest bitmap in the block change tracking file.

Consider the 8-bitmap limit when developing your incremental backup strategy. For example, if you make a level 0 database backup followed by 7 differential incremental backups, then the block change tracking file now includes 8 bitmaps. If you then make a cumulative level 1 incremental backup, RMAN cannot optimize the backup because the bitmap corresponding to the parent level 0 backup is overwritten with the bitmap that tracks the current changes.



#### See Also:

*Oracle Database Backup and Recovery User's Guide* for details about block change tracking

## Backups of Sparse Databases

RMAN enables you to back up sparse databases. This could include backing up a sparse data file, a tablespace containing some sparse data files, a PDB containing some sparse data files, and a CDB containing some sparse PDBs in the backup set or image copy format. A sparse backup is an RMAN object that contains data blocks of sparse data files from their dedicated delta storage space. To perform a sparse backup, the `COMPATIBLE` initialization parameter for the sparse database must be 12.2 or higher.

While performing a sparse backup, RMAN, by default, backs up data blocks of sparse data files from their delta storage space during a backup. It does not back up the logical data blocks from the backing data files. The backing data files in a sparse database environment must be read-only.

If you want to perform a traditional full or incremental backup on a sparse database to back up both, local and remote data blocks, then you can choose to run the backup with the `FROM NONSPARSE` option.

For databases with the `COMPATIBLE` initialization parameter less than 12.2, RMAN continues to perform the traditional backup and recovery operation for sparse databases in the non-sparse mode.

## Encryption of Backup Sets

RMAN can transparently encrypt data written to backup sets and decrypt those backup sets when they are needed in a `RESTORE` operation. To create encrypted backups on disk, the database must use the Advanced Security Option. To create encrypted backups directly on tape, RMAN must use the Oracle Secure Backup SBT interface, but does not require the Advanced Security Option. RMAN issues an `ORA-19916` error if you attempt to create encrypted RMAN backups using an SBT library other than Oracle Secure Backup.

RMAN can encrypt backups by using several different encryption algorithms, which are listed in `V$RMAN_ENCRYPTION_ALGORITHMS`. RMAN supports three modes of encryption for backups:

- Transparent encryption, in which RMAN can create and restore encrypted backups with no special DBA intervention if the data is already protected with Transparent Data Encryption (TDE) in the Oracle Database
- Password-based encryption, where a password is specified during the backup, and the same password must be supplied to restore the backup
- Dual-mode encryption, where backups can be created using either transparent encryption or password-based encryption, and where decryption can be performed based upon either the Oracle software keystore, or a password the DBA supplies at decryption time

 **Note:**

Keystore-based encryption is more secure than password-based encryption because no passwords are involved. Use password-based encryption only when absolutely necessary because your backups must be transportable.

The `CONFIGURE` and `SET` commands manage the encryption settings for database backups. See the reference entries for those commands for more details. Backup sets containing archived redo log files are encrypted if any of the following is true:

- `SET ENCRYPTION ON` is in effect when the backup is being created.
- Encryption is configured for the whole database or at least one tablespace.

 **See Also:**

- *Oracle Database Backup and Recovery User's Guide* for an overview of the backup encryption, a guide to its use, and information on choosing among different modes of encryption
- *Oracle Database Advanced Security Guide* to learn about TDE tablespace encryption and Oracle software keystores

## Backing Up Standby Databases

The RMAN `BACKUP` command backs up the standby database exactly the same as a primary database, except that the backup takes place on the standby site. The primary database has no influence on the backup of the standby database.

When you connect to the standby database to perform the backup, use the `TARGET` keyword and not the `AUXILIARY` keyword.

The state of the standby database when the backup is made determines whether the backup is consistent or inconsistent. To make a consistent backup, the standby database must shutdown cleanly and be mounted, but not placed in recovery mode. Any other status results in an inconsistent backup and must be restored using media recovery.

### RMAN Backups in a Data Guard Environment

A recovery catalog is required when you are performing RMAN operations in a Data Guard environment. The catalog enables all RMAN operations to be transparently executable at any primary or standby database. You can offload primary database backups onto any standby database in the environment; the RMAN backups are interchangeable. If you use RMAN in `NOCATALOG` mode, then RMAN uses only the metadata in the mounted control file.

In a Data Guard environment, the database that creates a backup or copy is associated with the file. For example, if RMAN connects as `TARGET` to database `prod` and backs it up, then this database backup is associated with `prod`. A backup remains associated with the database that created it unless you use the `CHANGE ... RESET DB_UNIQUE_NAME` to associate the backup with a different database.

The association of a backup is different from its accessibility. The recovery catalog considers disk backups as accessible only to the database in the Data Guard environment on which it was created, whereas tape backups created on one database are considered accessible to all databases. If a backup file is not associated with any database, then the row describing it in the recovery catalog view shows `null` for the `SITE_KEY` column. By default, RMAN associates files whose `SITE_KEY` is `null` with the database to which RMAN is connected as `TARGET`.

In a Data Guard environment, RMAN commands can operate on any backups that are accessible. For example, assume that databases `prod` and `standby1` reside on different hosts. RMAN backs up data file 1 on `prod` to `/prodhst/disk1/df1.dbf` on the production host and also to tape. RMAN backs up data file 1 on `standby1` to `/sby1hst/disk2/df1.dbf` on the standby host and also to tape. If RMAN is connected to database `prod` as `TARGET`, then you cannot use RMAN to perform operations with the `/sby1hst/disk2/df1.dbf` backup located on the standby host. However, RMAN considers the tape backup made on `standby1` as eligible to be restored.

#### Note:

You can FTP a backup from a standby host to a primary host or vice versa and then `CATALOG` it. After a file is cataloged by the target database, the file is associated with the target database.

If backups are accessible to RMAN, you can use RMAN maintenance commands such as `CHANGE`, `CROSSCHECK`, and `DELETE` for backups when connected to any primary or standby database.

**See Also:**

*Oracle Data Guard Concepts and Administration* to learn how to use RMAN to back up and restore files in a Data Guard environment

**Backing Up Data for Cross-Platform Transport**

The `BACKUP` command can create backup sets that are used to transport an entire database, data files, or tablespaces from one platform to another. To create cross-platform backups, use either the `FOR TRANSPORT` or `TO PLATFORM` clause in the `BACKUP` command. The `V$TRANSPORTABLE_PLATFORM` view contains the list of platforms supported for cross-platform transport.

**See Also:**

*Oracle Database Backup and Recovery User's Guide* for information about how to create backup sets for cross-platform data transportation

**List of Clauses Incompatible with TO PLATFORM and FOR TRANSPORT**

You can use the `BACKUP` command to create backup sets for cross-platform data transportation. To indicate that a backup is for cross-platform transportation, use either the `FOR TRANSPORT` or `TO PLATFORM` clauses.

When you use either the `FOR TRANSPORT` or `TO PLATFORM` clause, you cannot use the following clauses of the `BACKUP` command:

- `CUMULATIVE`
- `forRecoveryOfSpec`
- `keepOption`
- `notBackedUpSpec`
- `PROXY`
- `TAG`
- `VALIDATE`

**Syntax**

**`backup::=`**

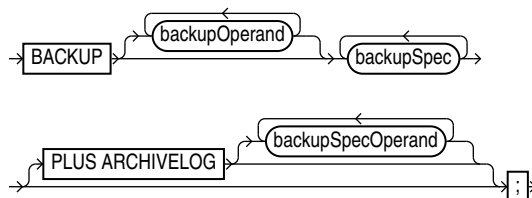

(backupOperand::=, backupSpec::=, backupSpecOperand::=)

**backupOperand::=**

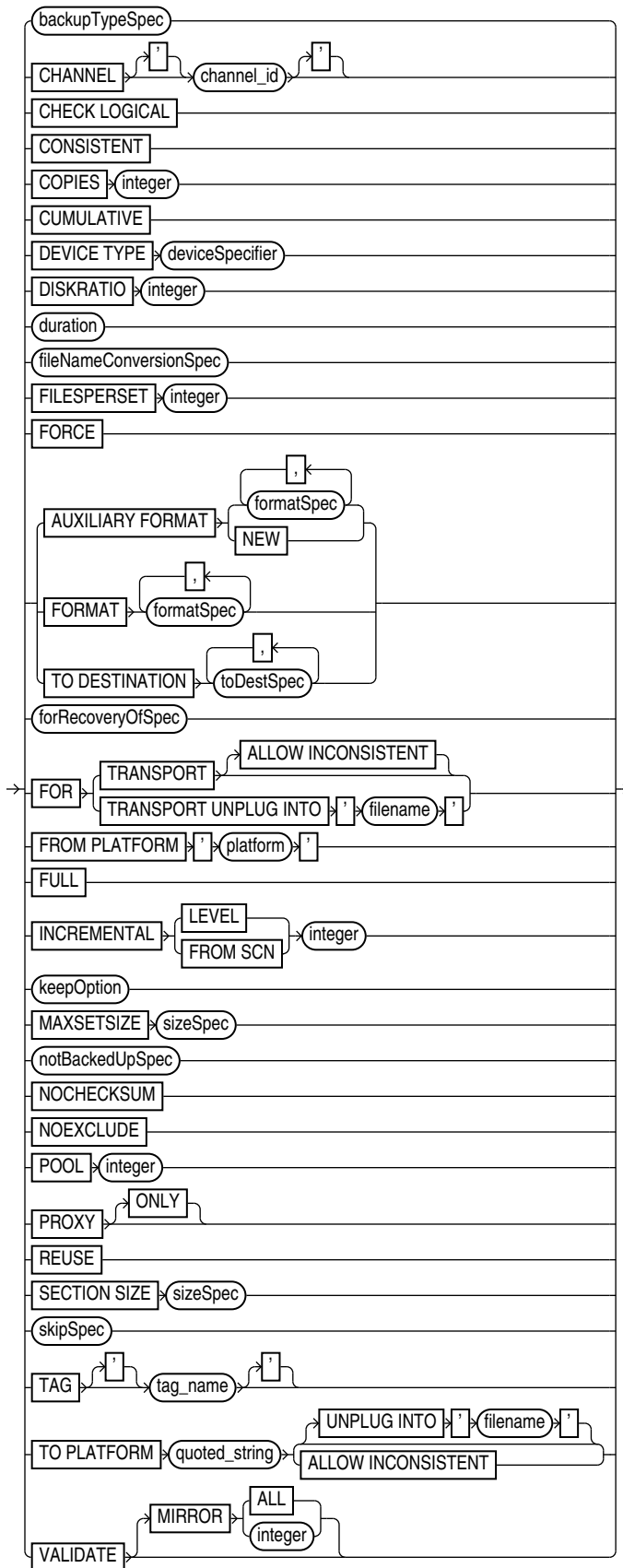



(backupTypeSpec::=, deviceSpecifier::=, fileNameConversionSpec::=, formatSpec::=, toDestSpec::=, forRecoveryOfSpec::=, keepOption::=, notBackedUpSpec::=, sizeSpec::=, skipSpec::=)

**backupSpec::=**

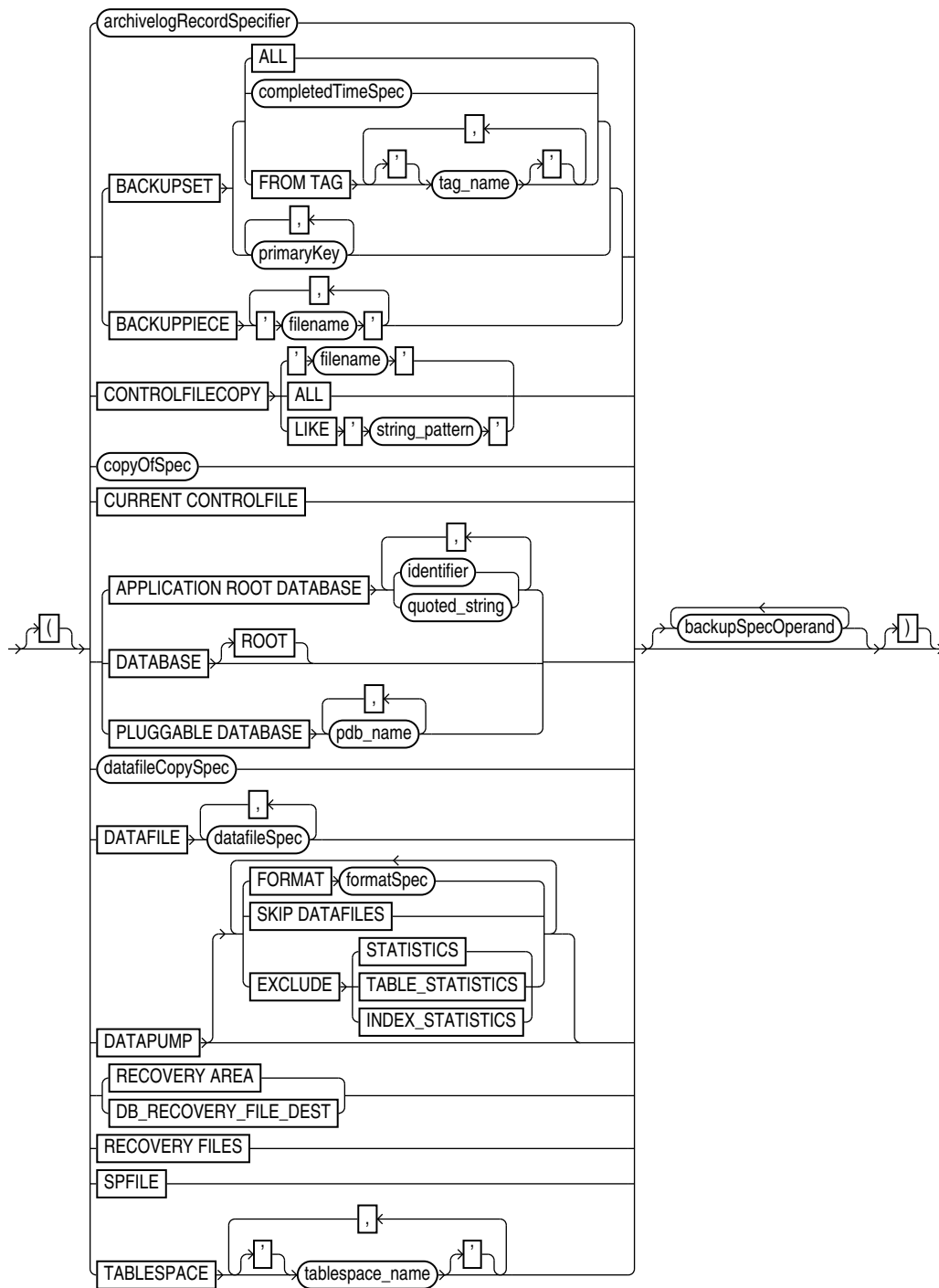

(archiveLogRecordSpecifier::=, completedTimeSpec::=, copyOfSpec::=, datafileCopySpec::=, datafileSpec::=, backupSpecOperand::=)

**backupSpecOperand::=**

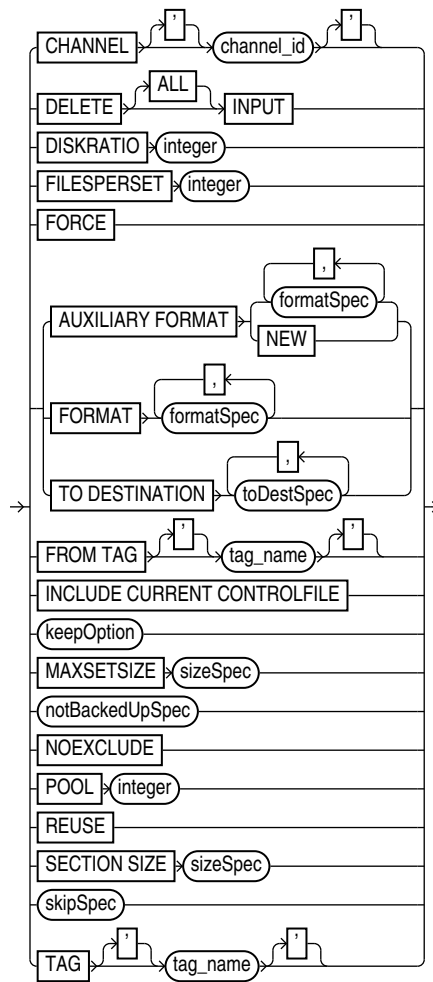

(formatSpec::=, toDestSpec::= keepOption::=, notBackedUpSpec::=, sizeSpec::=, skipSpec::=)

**backupTypeSpec::=**

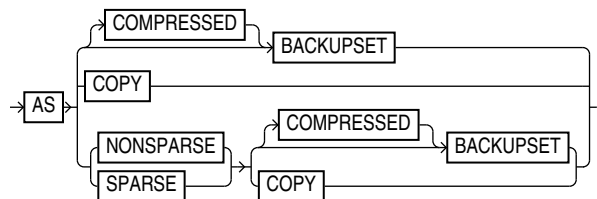

**copyOfSpec::=**

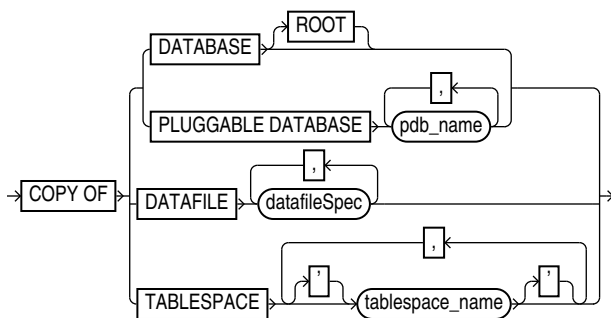

(*datafileSpec::=*)

***datafileCopySpec::=***

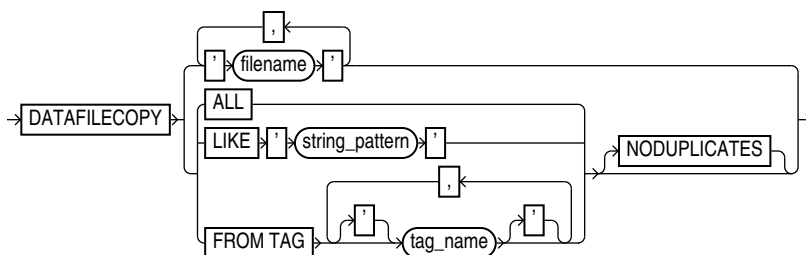

***duration::=***

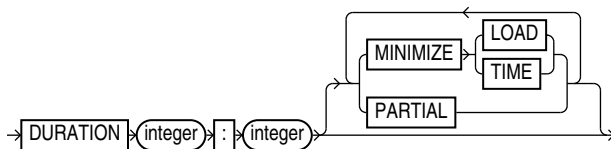

***forRecoveryOfSpec::=***

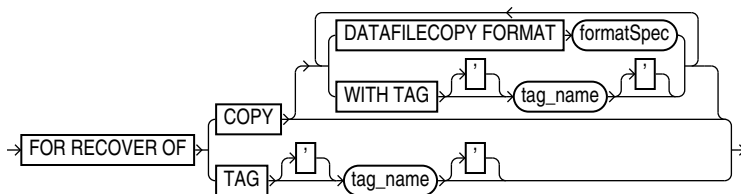

(*formatSpec::=*)

***notBackedUpSpec::=***

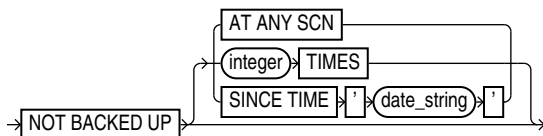

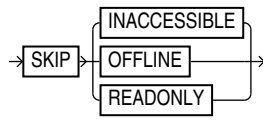
**skipSpec::=****Semantics****backup**

This clause specifies the objects to be backed up and the options to control the backup. Refer to [backupOperand::=](#) for the syntax diagram.

Syntax Element	Description
<a href="#">backupOperand</a>	Specifies various options for the BACKUP command.
<a href="#">backupSpec</a>	Specifies one or more objects to be backed up. Each <i>backupSpec</i> clause generates one or more backup sets ( <a href="#">AS BACKUPSET</a> ) or image copies ( <a href="#">AS COPY</a> ). For <code>AS BACKUPSET</code> , the <i>backupSpec</i> clause generates multiple backup sets if the number of data files specified in or implied by its list of objects exceeds the <code>FILESERSET</code> limit.
<code>PLUS ARCHIVELOG</code>	Includes archived redo log files in the backup (see <a href="#">Example 2-13</a> ). Causes RMAN to perform the following steps: <ol style="list-style-type: none"> <li>1. Run an <code>ALTER SYSTEM ARCHIVE LOG CURRENT</code> statement.</li> <li>2. Run the <code>BACKUP ARCHIVELOG ALL</code> command. If backup optimization is enabled, then RMAN only backs up logs that have not yet been backed up.</li> <li>3. Back up the files specified in the BACKUP command.</li> <li>4. Run an <code>ALTER SYSTEM ARCHIVE LOG CURRENT</code> statement.</li> <li>5. Back up any remaining archived redo log files. If backup optimization is not enabled, then RMAN backs up the logs generated in step 1 plus all the logs generated during the backup.</li> </ol> <p>In a CDB, you can backup archived redo logs only when you connect to the root as a common user with the <code>SYSDBA</code> or <code>SYSBACKUP</code> privilege. You cannot include archive logs in the backup when connected to a PDB.</p> <p><b>Note:</b> You cannot specify <code>PLUS ARCHIVELOG</code> on the <code>BACKUP ARCHIVELOG</code> command or <code>BACKUP AS COPY INCREMENTAL</code> command (or <code>BACKUP INCREMENTAL</code> command when the default backup type is <code>COPY</code>). You cannot specify <code>PLUS ARCHIVELOG</code> when also specifying <a href="#">INCREMENTAL FROM SCN</a>.</p> <p><b>Note:</b> Unless the online redo log is archived at the end of the backup, <code>DUPLICATE</code> is not possible with this backup.</p> <p><b>Note:</b> This clause cannot be used with the <code>KEEP UNTIL</code> clause.</p>
<a href="#">backupSpecOperand</a>	Specifies a variety of options and parameters that affect the <a href="#">backupSpec</a> clause.

**backupOperand**

This subclass specifies options such as the device type and output format. Refer to [backupOperand::=](#) for the syntax diagram.

Syntax Element	Description
<code>backupTypeSpec</code>	<p>Specifies the type of backup being created, either backup sets (<a href="#">AS BACKUPSET</a>) or image copies (<a href="#">AS COPY</a>).</p> <p><b>See Also:</b> <a href="#">backupTypeSpec</a> for details</p>
<code>CHANNEL channel_id</code>	<p>Specifies the case-sensitive name of a channel to use when creating backups. Use any meaningful name, for example <code>ch1</code> or <code>dev1</code>. The database uses the channel ID to report I/O errors. If you do not set this parameter, then RMAN dynamically assigns the backup sets to any available channels during execution. As shown in <a href="#">Example 2-23</a>, you can use <code>CHANNEL</code> to specify which channels back up which files.</p> <p><b>Note:</b> You can also specify this parameter in the <a href="#">backupSpec</a> clause.</p>
<code>CHECK LOGICAL</code>	<p>Tests data and index blocks that pass physical corruption checks for logical corruption (see <a href="#">Example 2-25</a>). This option typically adds 1-3% overhead. Examples of logical corruption are corruption of a row piece or index entry. If RMAN finds logical corruption, then it logs the block in the alert log and server session trace file. The <code>SET MAXCORRUPT</code> command specifies the total number of physical and logical corruptions permitted in a data file.</p> <p>By default, the <code>BACKUP</code> command computes a checksum for each block and stores it in the backup. If you specify the <code>NOCHECKSUM</code> option, then RMAN does not perform a checksum of the blocks when writing the backup.</p> <p>If <code>SET MAXCORRUPT</code> and <code>NOCHECKSUM</code> are not set, then <code>CHECK LOGICAL</code> detects all types of corruption that are possible to detect during a backup.</p>
<code>CONSISTENT</code>	<p>Creates consistent backupsets of the specified database or PDB. A single consistent backup is sufficient to restore a database or a PDB to a consistent state.</p> <p><b>Note:</b> This clause cannot be used with the <code>KEEP</code> and <code>AS COPY</code> options.</p>
<code>COPIES integer</code>	<p>Sets the number of identical backups (1 - 4) that RMAN creates. The default value is 1.</p> <p>You can use multiple format strings to specify different names and locations for the copies. <a href="#">Example 2-22</a> illustrates a duplexed backup to different locations on disk.</p> <p>RMAN can duplex backups to either disk or tape, but cannot duplex backups to tape and disk simultaneously. When backing up to tape, ensure that the number of copies does not exceed the number of available tape devices. Also, if <code>COPIES</code> is greater than 1, then the <code>BACKUP_TAPE_IO_SLAVES</code> initialization parameter must be enabled on the target database.</p> <p>You can specify duplexing in multiple commands. The order of precedence is as follows, with settings higher on the list overriding lower settings:</p> <ol style="list-style-type: none"> <li>1. <code>BACKUP COPIES</code></li> <li>2. <code>SET BACKUP COPIES</code></li> <li>3. <code>CONFIGURE . . . BACKUP COPIES</code></li> </ol> <p><b>Note:</b> This option does not apply with <code>AS COPY</code> and results in an error message.</p> <p><b>Note:</b> Duplexing cannot be used when creating files in the fast recovery area.</p>
<code>CUMULATIVE</code>	<p>Copies the data blocks used since the most recent level 0 backup (see <a href="#">Example 2-16</a>).</p> <p><b>Note:</b> This option does not apply with <code>AS COPY</code> and results in an error message.</p>

Syntax Element	Description
<code>DEVICE TYPE</code> <a href="#">deviceSpecifier</a>	<p>Allocates automatic channels for the specified device type only. For example, if you configure disk and tape channels, then configure <code>sbt</code> as the default device type, then the following command allocates disk channels only:</p> <pre>BACKUP DEVICE TYPE DISK DATABASE;</pre> <p>The <code>DEVICE TYPE</code> option is valid only for automatic channels and is not valid for manually allocated channels. You cannot use the <code>DEVICE TYPE</code> option for a device other than <code>DISK</code> if you have not run <a href="#">CONFIGURE DEVICE TYPE</a> for this device.</p> <p><b>Note:</b> To specify a disk channel for the <code>BACKUP RECOVERY AREA</code> command, you must use the <code>TO DESTINATION</code> of the subclause <a href="#">toDestSpec</a>.</p> <p><b>See Also:</b> <a href="#">deviceSpecifier</a></p>
<code>DISKRATIO</code> <i>integer</i>	<p>Directs RMAN to populate each backup set with data files from at least <i>integer</i> disks.</p> <p>This parameter is only enabled when you are backing up data files or control files, and when the operating system can give RMAN disk contention and node affinity data. To manually disable this feature, set <code>DISKRATIO</code> to 0.</p> <p>For example, assume that data files are distributed across 10 disks. If the disks supply data at 10 bytes/second, and if the tape drive requires 50 bytes/second to keep streaming, then set <code>DISKRATIO</code> to 5 to direct RMAN to include data files from at least 5 disks in each backup set.</p> <p>If you set <a href="#">FILESERSET</a> but not <code>DISKRATIO</code>, then <code>DISKRATIO</code> defaults to the same value as <code>FILESERSET</code>. If you specify neither parameter, then <code>DISKRATIO</code> defaults to 4. RMAN compares the <code>DISKRATIO</code> value to the actual number of devices involved in the backup and uses the lowest value. For example, if <code>DISKRATIO</code> is 4 and the data files are located on three disks, then RMAN attempts to include data files from three disks in each backup set.</p> <p>The <code>DISKRATIO</code> parameter is easier for data file backups when the data files are striped or reside on separate disk spindles and you either:</p> <ul style="list-style-type: none"> <li>• Use a high-bandwidth tape drive that requires several data files to be multiplexed to keep the tape drive streaming.</li> <li>• Make backups while the database is open and spread the I/O load across several disk spindles to leave bandwidth for online operations.</li> </ul> <p><b>Note:</b> Do not spread I/O over more than the minimum number of disks required to keep the tape streaming. Otherwise, you increase restore time for a file without increasing performance.</p>
<a href="#">duration</a>	<p>Specifies options related to the maximum time for a backup command to run.</p> <p><b>See Also:</b> <a href="#">duration</a></p>
<a href="#">fileNameConversionSpec</a>	<p>This option is valid only when <code>BACKUP</code> is creating image copies. Files being copied are renamed according to the specified patterns. If a file being backed up has a name that does not match any of the specified rename patterns, then RMAN uses <a href="#">FORMAT</a> to name the output image copies. If no <code>FORMAT</code> is specified, then RMAN uses the default format <code>%U</code>.</p> <p><b>See Also:</b> <a href="#">fileNameConversionSpec</a> for file renaming patterns</p>

Syntax Element	Description
<code>FILESPPERSET integer</code>	<p>Specifies the maximum number of input files to include in each output backup set. This parameter is only relevant when <code>BACKUP</code> generates backup sets.</p> <p>RMAN backs up the files in each <code>backupSpec</code> as one or more backup sets. When the number of files in each <code>backupSpec</code> exceeds the <code>FILESPPERSET</code> setting, then RMAN splits the files into multiple backup sets accordingly. The default value for <code>FILESPPERSET</code> is 64.</p> <p>The RMAN behavior is illustrated by the following <code>BACKUP</code> commands:</p> <pre>BACKUP AS BACKUPSET (DATAFILE 3, 4, 5, 6, 7) (DATAFILE 8, 9); BACKUP AS BACKUPSET DATAFILE 3, 4, 5, 6, 7, 8, 9; BACKUP AS BACKUPSET DATAFILE 3, ... 72;</pre> <p>In the first command, RMAN places data files 3, 4, 5, 6, and 7 into one backup set and data files 8 and 9 into another backup set. In the second command, RMAN places all data files into one backup set. In the third command, the ellipses indicate data files 3 through 72. Because in this case RMAN is backing up 70 data files, RMAN places 64 files in one backup set and 6 in another.</p> <p>By default, RMAN divides files among backup sets to make optimal use of channel resources. The number of files to be backed up is divided by the number of channels. If the result is less than 64, then this number is the <code>FILESPPERSET</code> value. Otherwise, <code>FILESPPERSET</code> defaults to 64.</p> <p><b>Note:</b> You cannot specify the number of backup pieces that are in a backup set.</p>
<code>FORCE</code>	<p>Forces RMAN to ignore backup optimization. That is, even if <code>CONFIGURE BACKUP OPTIMIZATION</code> is set to <code>ON</code>, RMAN backs up all specified files.</p> <p><b>Note:</b> You can also specify this option in the <code>backupSpecOperand</code> clause.</p> <p>The command <code>BACKUP DATABASE FORCE PLUS ARCHIVELOG</code> is equivalent to <code>BACKUP DATABASE PLUS ARCHIVELOG FORCE</code>.</p>
<code>AUXILIARY FORMAT</code>	<p>Copies the files on the target database to the specified location on the auxiliary instance. RMAN can only generate image copies when <code>AUXILIARY FORMAT</code> is specified. RMAN must be connected to both <code>TARGET</code> and <code>AUXILIARY</code> instances and have access to auxiliary channels.</p> <p>You can use the <code>BACKUP AUXILIARY FORMAT</code> command to copy data files, archived logs, controlfile, and server parameter file (spfile) over the network between primary and standby databases. For example, if a data file on a primary database was lost, you could <code>CONNECT</code> to the standby database as <code>TARGET</code> and the primary database as <code>AUXILIARY</code>, and copy an intact data file from the standby host to the primary host.</p> <p><b>See Also:</b> <a href="#">Example 2-30</a></p>
<code>formatSpec</code>	<p>Specifies a pattern for naming the output image copies on an auxiliary instance. The path must be valid on the auxiliary host.</p> <p><b>See Also:</b> <code>formatSpec</code> for valid substitution variables</p>
<code>NEW</code>	<p>Creates an image copy in the directory specified in the <code>DB_CREATE_FILE_DEST</code> initialization parameter of the auxiliary instance. The image copy is an Oracle-managed file.</p>

Syntax Element	Description
FORMAT <a href="#">formatSpec</a>	<p>Specifies a pattern for naming the output backup pieces or image copies (see <a href="#">Example 2-17</a>). For <code>AS COPY</code>, if one or more of the directories mentioned in the specified format does not exist, then RMAN signals an error.</p> <p>The default location for disk backups depends on whether a fast recovery area is enabled and whether <code>FORMAT</code> is specified:</p> <ul style="list-style-type: none"> <li>• If a fast recovery area is enabled, and if you <i>do</i> specify <code>FORMAT</code>, then RMAN names the output files according to the <code>FORMAT</code> setting. If no location is specified in <code>FORMAT</code>, then RMAN creates the backup in a platform-specific location—not in the recovery area.</li> <li>• If a fast recovery area is enabled, and if you do <i>not</i> specify <code>FORMAT</code>, then RMAN creates the backup in the recovery area and uses the substitution variable <code>%U</code> to name the backup.</li> <li>• If a fast recovery area is <i>not</i> enabled, and if you do <i>not</i> specify <code>FORMAT</code>, then RMAN creates the backup in a platform-specific location and uses <code>%U</code> to name the backup.</li> </ul> <p>To create RMAN backups in the fast recovery area with names in Oracle Managed Files format, do not specify the <code>FORMAT</code> clause on the <code>BACKUP</code> command or channel.</p> <p><b>Note:</b> You cannot specify an Oracle Managed Files file name as the format for a backup. For example, if <code>+DISK1/datafile/system.732.609791431</code> is an OMF file name, then you cannot specify this file name in the <code>FORMAT</code> parameter.</p> <p>Backup pieces must have unique names. The maximum length of a backup piece file name is platform-specific. For backups to a media manager, the length is also limited by the limit in the supported version of the media management API. Vendors supporting SBT 1.1 must support file names up to 14 characters. Some SBT 1.1 vendors may support longer file names. Vendors supporting SBT 2.0 must support file names up to 512 characters. Some SBT 2.0 vendors may support longer file names.</p> <p>You cannot specify multiple, identical <code>FORMAT</code> strings within a single <a href="#">backupSpec</a> (for example, <code>BACKUP DATAFILE 3 TO '/tmp/df3.f', DATAFILE 4 TO '/tmp/df4.f'</code>). However, RMAN permits a single <code>FORMAT</code> string to exist in multiple <a href="#">backupSpec</a> clauses.</p> <p><b>Note:</b> If you are making an archival backup with the <code>KEEP</code> option (see <a href="#">Example 2-26</a>), then the format string must contain <code>%U</code>. The autobackup also uses this format string.</p> <p><b>See Also:</b> <a href="#">formatSpec</a> for valid substitution variables</p>
TO DESTINATION <a href="#">toDestSpec</a>	<p>Specifies the directory where the backup is created. This parameter is valid for disk and not SBT channels. The backup files are created in an Oracle Managed Files (OMF) directory. Backup skips the files only when backups do not exist in the specified <code>TO DESTINATION</code>.</p>
<a href="#">forRecoveryOfSpec</a>	<p>Identifies the backup being created as an incremental backup to be used in rolling forward an image copy.</p> <p><b>See Also:</b> <a href="#">forRecoveryOfSpec</a></p>



Syntax Element	Description
FOR TRANSPORT	<p>Creates a cross-platform backup using backup sets. You can back up data files, tablespaces, or an entire database. While creating a cross-platform tablespace backup, use the <code>DATA PUMP</code> clause to back up the metadata of the transported tablespaces. This metadata is used on the destination database to plug in the transported tablespaces.</p> <p>Backup sets created by a cross-platform backup are not catalogued in the control file.</p> <p>Before you backup the whole database for cross-platform transport, ensure that the database is in read-only mode. You can transport a database only if the source and destination use the same endian format.</p> <p>While backing up tablespaces, the tablespaces being backed must be in read-only mode, unless the <code>ALLOW INCONSISTENT</code> clause is used. To transport tablespaces, the source and destination can use different endian formats. When <code>FOR TRANSPORT</code> is used, endian conversion is performed on the destination database.</p> <p><b>See Also:</b> <a href="#">"Backing Up Data for Cross-Platform Transport"</a></p> <p><b>Note:</b> Cross-platform backups using backup sets are supported from Oracle Database 12c Release 1 (12.1).</p>
ALLOW INCONSISTENT	<p>Enables you to backup tablespaces that are not in read-only mode.</p> <p>You cannot use <code>ALLOW INCONSISTENT</code> for cross-platform whole database backups.</p> <p>Although the backup is created, you cannot plug these tablespaces directly into the target database because they are inconsistent. You must later create an incremental backup of the tablespaces when they are in read-only mode. This incremental backup must contain the <code>DATA PUMP</code> clause, which is used to create a backup set containing an export dump file of the tablespace metadata.</p> <p><b>See Also:</b> <i>Oracle Database Backup and Recovery User's Guide</i> for more information about creating an restoring inconsistent tablespace backups.</p>
FOR TRANSPORT UNPLUG INTO <i>filename</i>	<p>Creates a cross-platform consistent backup of a PDB using backup sets. The metadata required to plug the PDB into a different CDB is stored in the XML file specified using <i>filename</i>.</p> <p>You can use this backup to perform cross-platform transport of the PDB to any supported platform. The PDB that is being transported must be closed before it is unplugged. The CDB to which this PDB belongs must be in read-write mode.</p>
FULL	<p>Creates a backup of all blocks of data files included in the backup. <code>FULL</code> is the opposite of <code>INCREMENTAL</code>. <code>RMAN</code> makes full backups by default if neither <code>FULL</code> nor <code>INCREMENTAL</code> is specified.</p> <p>A full backup has no effect on subsequent incremental backups and is not considered a part of any incremental backup strategy. A full image copy backup can be incrementally updated, however, by applying incremental backups with the <code>RECOVER</code> command.</p> <p><b>Note:</b> Unused block compression, which is described in the entry for <code>BACKUP AS BACKUPSET</code>, causes some data file blocks to be skipped during full backups.</p>
INCREMENTAL LEVEL <i>integer</i>	<p>Copies only those data blocks that have changed since the last incremental <i>integer</i> backup, where <i>integer</i> is 0 or 1 (see <a href="#">Example 2-16</a>).</p> <p>See <a href="#">"Incremental Backups"</a> for an explanation of incremental backups.</p>

Syntax Element	Description
INCREMENTAL FROM SCN <i>integer</i>	<p>Creates an incremental backup of all specified data files that includes all data file blocks changed at SCNs greater than or equal to the specified SCN.</p> <p>One use of this option is to refresh a standby database with changes from the primary database (see <a href="#">Example 2-24</a>, and the chapter on RMAN backups in <i>Oracle Data Guard Concepts and Administration</i>). This backup contains all changed blocks since the standby database was created or last synchronized. At the standby database, you can use <a href="#">RECOVER</a> with <code>NOREDO</code> to apply the incremental backup. All changed blocks captured in the incremental backup are applied at the standby database, bringing it current with the primary database.</p> <p>If you are <i>not</i> making incremental backups based on Volume Shadow Copy Service (VSS) snapshots, then specify <a href="#">formatSpec</a> when you specify <code>INCREMENTAL FROM SCN</code>. The <code>FORMAT</code> string should include substitution variables such as <code>%U</code> because RMAN generates a control file backup.</p> <p>If you specify <code>FROM SCN</code> with the <code>NOKEEP</code> option, and if you do <i>not</i> specify <a href="#">formatSpec</a> when you specify <code>INCREMENTAL FROM SCN</code>, then RMAN creates incremental backups in the fast recovery area so that you can create incremental backups based on VSS snapshots in a Windows environment. In this way, you can use incremental backup sets and VSS shadow copies in conjunction. The checkpoint SCN value specified in the <code>FROM SCN</code> parameter should be same as the <code>BACKUP_CHECKPOINT</code> value in the VSS backup metadata document. If block change tracking is enabled, then the backups use the change tracking mechanism, which significantly reduces the time taken to create incremental backups. RMAN can apply incremental backups from the fast recovery area during recovery transparently.</p> <p><b>Note:</b> You cannot use <code>PLUS ARCHIVELOG</code> when also specifying <code>INCREMENTAL FROM SCN</code>.</p> <p><b>See Also:</b> <i>Oracle Database Platform Guide for Microsoft Windows</i> to learn about making backups with VSS</p>
<a href="#">keepOption</a>	<p>Overrides any configured retention policy for this backup so that the backup is not considered obsolete, as shown in <a href="#">Example 2-26</a>.</p> <p>You can use the <code>KEEP</code> syntax to generate archival database backups that satisfy business or legal requirements. The <code>KEEP</code> setting is an attribute of the backup set (not individual backup piece) or image copy.</p> <p><b>Note:</b> You cannot use <code>KEEP</code> with <code>BACKUP BACKUPSET</code>.</p> <p>With the <code>KEEP</code> syntax, you can keep the backups so that they are considered obsolete after a specified time (<code>KEEP UNTIL</code>), or make them never obsolete (<code>KEEP FOREVER</code>). As shown in <a href="#">Example 2-27</a>, you must be connected to a recovery catalog when you specify <code>KEEP FOREVER</code>.</p> <p><b>Note:</b> You can use <a href="#">CHANGE</a> to alter the status of a backup generated with <code>KEEP</code>.</p> <p><b>Note:</b> You cannot use <code>KEEP UNTIL</code> with <code>PLUS ARCHIVELOG</code>.</p> <p><b>See Also:</b> <a href="#">keepOption</a> for more information about backups made with the <code>KEEP</code> option</p>

Syntax Element	Description
<code>MAXSETSIZE</code> <a href="#">sizeSpec</a>	<p>Specifies a maximum size for a backup set (as shown in <a href="#">Example 2-17</a>). RMAN limits all backup sets to this size.</p> <p>It is possible for a backup set to span multiple tapes, so blocks from each data file are written to multiple tapes. If one tape of a multivolume backup set fails, then you lose the data on all the tapes rather than just one. Because a backup set always includes a whole file rather than part of a file, you can use <code>MAXSETSIZE</code> to specify that each backup set can fit on one tape.</p> <p>Specify size in bytes (default), kilobytes (K), megabytes (M), or gigabytes (G). For example, to limit a backup set to 3 MB, specify <code>MAXSETSIZE 3M</code>. The default size is in bytes, rounded down from kilobytes. For example, <code>MAXSETSIZE 3000</code> is rounded down to 2 KB (2048 bytes). The minimum value must be greater than or equal to the database block size.</p> <p>The default number of files in each backup set is determined by <code>FILESERSET</code>, which defaults to 64. When you specify <code>MAXSETSIZE</code>, RMAN attempts to limit the size in bytes of the backup sets according to the <code>MAXSETSIZE</code> parameter. The limit on the number of files in a backup set applies even if the total size of the resulting backup set is less than <code>MAXSETSIZE</code>.</p> <p><b>Note:</b> This option results in an error message if used with <code>BACKUP AS COPY</code>. If you run <code>BACKUP AS COPY</code> on a channel that has <code>MAXSETSIZE</code> set, then <code>MAXSETSIZE</code> is silently ignored.</p>
<a href="#">notBackedUpSpec</a>	<p>Limits the set of archived redo log files to be backed up according to whether a specified number of backups are present (and not obsolete), or whether the logs have been backed up since a specified date.</p> <p><b>See Also:</b> <a href="#">notBackedUpSpec</a></p>
<code>NOCHECKSUM</code>	<p>Suppresses block checksums during the backup.</p> <p>A checksum is a number that is computed from the contents of a data block. <code>DB_BLOCK_CHECKSUM</code> is a database initialization parameter that controls the writing of checksums for the blocks in data files in the database (not backups). If <code>DB_BLOCK_CHECKSUM</code> is <code>typical</code>, then the database computes a checksum for each block during normal operations and stores it in the block before writing it to disk. When the database reads the block from disk later, it recomputes the checksum and compares it to the stored value. If they do not match, then the block is damaged.</p> <p><b>Note:</b> You cannot disable checksums for data files in the <code>SYSTEM</code> tablespace even if <code>DB_BLOCK_CHECKSUM=false</code>.</p> <p>By default, the <code>BACKUP</code> command computes a checksum for each block and stores it in the backup. The <code>BACKUP</code> command ignores the values of <code>DB_BLOCK_CHECKSUM</code> because this initialization parameter applies to data files in the database, not backups. If you specify the <code>NOCHECKSUM</code> option, then RMAN does not perform a checksum of the blocks when writing the backup.</p> <p>When restoring a backup data file, RMAN honors the <code>DB_BLOCK_CHECKSUM</code> initialization parameter setting. RMAN clears the checksum if <code>DB_BLOCK_CHECKSUM</code> is set to <code>false</code>. If set to <code>typical</code>, then RMAN verifies the checksum when restoring from the backup and writing to the data file.</p> <p><b>Note:</b> You can turn off checksum checking by specifying <code>NOCHECKSUM</code>, but other physical consistency checks, such as checks of the block headers and footers, cannot be disabled.</p> <p><b>See Also:</b> <i>Oracle Database Reference</i> for more information about the <code>DB_BLOCK_CHECKSUM</code> initialization parameter</p>

Syntax Element	Description
NOEXCLUDE	When specified on a <code>BACKUP DATABASE</code> or <code>BACKUP COPY OF DATABASE</code> command, RMAN backs up all tablespaces, including any for which a <code>CONFIGURE EXCLUDE</code> command has been entered. This option does not override <code>SKIP OFFLINE</code> or <code>SKIP READONLY</code> .
<code>POOL integer</code>	Specifies the media pool in which the backup is stored. Consult your media management documentation to see whether <code>POOL</code> is supported. <b>Note:</b> This option does not work with <code>AS COPY</code> and results in an error.
PROXY	Backs up the specified files with the proxy copy functionality, which gives the media management software control over the data transfer between storage devices and the data files on disk. The media manager—not RMAN—decides how and when to move data. When you run <code>BACKUP</code> with the <code>PROXY</code> option, RMAN performs these steps: <ol style="list-style-type: none"> <li>1. Searches for a channel of the specified device type that is proxy-capable. If no such channel is found, then RMAN issues a warning and attempts a conventional (that is, non-proxy) backup of the specified files.</li> <li>2. If RMAN locates a proxy-capable channel, then it calls the media manager to check if it can proxy copy the files. If the media manager cannot proxy copy, then RMAN uses conventional backup sets to back up the files.</li> </ol> <b>Note:</b> If you specify <code>PROXY</code> , then the <code>%p</code> variable must be included in the <code>FORMAT</code> string either explicitly or implicitly within <code>%U</code> . <b>Note:</b> This option does not work with <code>AS COPY</code> and results in an error.
ONLY	Causes the database to issue an error message when it cannot proxy copy rather than creating conventional backup sets. If you do not want RMAN to try a conventional copy when a proxy copy fails, use the <code>ONLY</code> option.
REUSE	Enables RMAN to overwrite an existing backup or copy with the same name as the file that <code>BACKUP</code> is currently creating.
<code>SECTION SIZE sizeSpec</code>	Specifies the size of each backup section produced during a data file or data file copy backup. By setting this parameter, RMAN can create a <b>multisection backup</b> . In a multisection backup, RMAN creates a backup piece that contains one <b>file section</b> , which is a contiguous range of blocks in a file. All sections of a multisection backup are the same size. File sections enable RMAN to create multiple steps for the backup of a single large data file. RMAN channels can process each step independently and in parallel, with each channel producing one section of a multisection backup set. Multisection backups can be stored either as image copies or backup sets (both full and incremental). To create multisection image copies or incremental backups, the <code>COMPATIBLE</code> parameter must be 12.0.0 or higher. <b>See Also:</b> <i>Oracle Database Backup and Recovery User's Guide</i> for more information about multisection image copies. <b>Note:</b> RMAN always creates multisection backups with <code>FILESPERSET</code> set to 1. If you specify a section size that is larger than the size of the file, then RMAN does not use multisection backup for the file. If you specify a small section size that would produce more than 256 sections, then RMAN increases the section size to a value that results in exactly 256 sections. <b>Note:</b> Depending on where you specify this parameter in the RMAN syntax, you can specify different section sizes for different files in the same backup job. <b>Note:</b> You cannot use <code>SECTION SIZE</code> with <code>MAXPIECESIZE</code> .

Syntax Element	Description
<a href="#">skipSpec</a>	Excludes data files or archived redo log files from the backup if they are inaccessible, offline, or read-only. <b>See Also:</b> <a href="#">skipSpec</a> for details.
TAG <i>tag_name</i>	Specifies a user-specified tag name for a backup set, proxy copy, data file copy, or control file copy. The tag is applied to the output files generated by the <code>BACKUP</code> command.  The tag name is not case-sensitive. The name must be 30 characters or less. The characters are limited to the characters that are valid in file names on the target file system. For example, ASM does not support the use of the hyphen (-) character in the file names it uses internally, so <code>weekly-incremental</code> is not a valid tag name for backups in ASM disk groups. Environment variables are not valid in the <code>TAG</code> parameter.  Typically, a tag name is a meaningful name such as <code>MON_PM_BKUP</code> or <code>WEEKLY_FULL_BKUP</code> . Tags are reusable, so that backup set 100 can have the tag <code>MON_PM_BKUP</code> one week while backup set 105 has the same tag the next week.  If you do not specify a tag name, then by default RMAN creates a tag for backups (except for control file autobackups). The default tag uses the format <code>TAGYYYYMMDDTHHMMSS</code> , where <code>YYYY</code> is the year, <code>MM</code> is the month, <code>DD</code> is the day, <code>HH</code> is the hour (in 24-hour format), <code>MM</code> is the minutes, and <code>SS</code> is the seconds. For example, a backup of data file 1 might receive the tag <code>TAG20130208T133437</code> . The date and time refer to when RMAN started the backup. If multiple backup sets are created by one <code>BACKUP AS BACKUPSET</code> command, then each backup piece is assigned the same default tag.  You can also specify the tag at the <a href="#">backupSpec</a> level. If you specify the tag at: <ul style="list-style-type: none"> <li>• The command level, then all backup sets created by the command have the tag.</li> <li>• The <code>backupSpec</code> level, then backup sets created with different backup specifications can have different tags.</li> <li>• Both levels, then the tag in the <code>backupSpec</code> takes precedence.</li> </ul> <b>Note:</b> A tag is an attribute of each backup piece in a given copy of a backup set (for <code>AS BACKUPSET</code> ) or each image copy (for <code>AS COPY</code> ). For example, if you run <code>BACKUP AS BACKUPSET COPIES 1 DATABASE TAG TUE_PM</code> , then only one copy of the backup set exists and each backup piece has tag <code>TUE_PM</code> . Assume that this backup set has primary key 1234. If you then run <code>BACKUP BACKUPSET 1234 TAG WED_PM</code> , then the first copy of the backup set has tag <code>TUE_PM</code> and the second copy of the backup set has tag <code>WED_PM</code> .

Syntax Element	Description
<code>TO PLATFORM 'platform'</code>	<p>Specifies the full name of the destination platform to which the cross-platform backup will be transported. If you omit <code>TO PLATFORM</code>, RMAN assumes that the destination platform is the same as the source platform.</p> <p>Backup sets created by a cross-platform backup are not catalogued in the control file.</p> <p>You can use either <code>FOR TRANSPORT</code> or <code>TO PLATFORM</code> to indicate that a backup is a cross-platform backup. If you specify a platform name using <code>TO PLATFORM</code>, endianness conversion, if required, is performed on the source platform. Therefore, you can restore this cross-platform backup only on the specified platform. If you omit <code>TO PLATFORM</code>, you can restore this cross-platform backup on any supported platform. The <code>V\$TRANSPORTABLE_PLATFORM</code> view provides information about the supported platforms.</p> <p><b>See Also:</b> "<a href="#">FOR TRANSPORT</a>"</p> <p><b>See Also:</b> "<a href="#">Backing Up Data for Cross-Platform Transport</a>" for information about the mode in which the database or tablespace is opened before creating a cross-platform backup</p> <p><b>Note:</b> Cross-platform backups using backup sets are supported from Oracle Database 12c Release 1 (12.1).</p>
<code>ALLOW INCONSISTENT</code>	<p>Enables you to backup tablespaces that are not in read-only mode.</p> <p>You cannot use <code>ALLOW INCONSISTENT</code> for cross-platform whole database backups.</p> <p><b>See Also:</b> "<a href="#">ALLOW INCONSISTENT</a>"</p>
<code>TO PLATFORM UNPLUG INTO filename</code>	<p>Creates a cross-platform consistent backup of a PDB using backup sets. The metadata required to plug the PDB into a different CDB is stored in the XML file specified using <i>filename</i>.</p> <p>You use this backup to perform cross-platform transport of the PDB to the specified platform. The PDB must be closed before it is unplugged. The CDB must be in read-write mode.</p>
<code>VALIDATE</code>	<p>Scans the specified files and verifies their contents, testing whether this file can be backed up and whether the data blocks are corrupt.</p> <p>RMAN creates no output files. This option is equivalent to using the <a href="#">VALIDATE</a> command on the database files specified in the backup.</p> <p>If you do not specify <code>CHECK LOGICAL</code>, then <code>BACKUP VALIDATE</code> checks for physical corruption only. If you specify <code>CHECK LOGICAL</code>, then <code>BACKUP VALIDATE</code> checks for both physical and logical corruption. RMAN populates the <code>V\$DATABASE_BLOCK_CORRUPTION</code> view with any corruptions that it finds.</p> <p>You can use the <a href="#">SET MAXCORRUPT</a> command to set a limit for the number of corrupt blocks tolerated during the backup validation. The default is zero.</p> <p>If you execute <code>BACKUP INCREMENTAL</code> with <code>VALIDATE</code>, then the behavior depends on whether block change tracking is enabled. If change tracking is enabled, then RMAN validates only changed blocks; otherwise, RMAN validates all blocks in the files included in the backup.</p> <p><b>Note:</b> You cannot validate backups of backup sets.</p>

### **backupSpec**

This subclause specifies a list of one or more objects to be backed up. Each *backupSpec* clause generates one or more backup sets ([AS BACKUPSET](#)) or image copies ([AS COPY](#)). For [AS BACKUPSET](#), the *backupSpec* clause generates multiple backup sets if the number of data files specified in or implied by its list of objects exceeds the default limit of 4 data files or 16 archived redo log files in each backup set. Refer to [backupSpec::=](#) for the syntax diagram.

---

Syntax Element	Description
<a href="#">archivelogRecordSpecifier</a>	<p>Specifies a range of archived redo log files to be backed up.</p> <p>To back up archived redo logs in a CDB, connect to the root as a common user with the SYSDBA or SYSBACKUP privilege. You cannot back up archived redo logs when connected to a PDB.</p> <p>When backing up archived redo log files, RMAN can perform archived log failover automatically. RMAN backs up the log when at least one archived log corresponding to a given log sequence number and thread is available. Also, if the copy that RMAN is backing up contains corrupt blocks, then it searches for good copies of these blocks in other copies of the same archived redo log files.</p> <p>RMAN does not signal an error if the command finds no logs to back up, since this situation probably exists because no new logs were generated after the previous <code>BACKUP ARCHIVELOG ALL DELETE INPUT</code> command. The only exception to this behavior is when the <code>SEQUENCE</code> number clause is specified. In this scenario, RMAN signals the <code>RMAN-06004</code> error if an archived redo log file of the specified sequence is not found.</p> <p>If you specify <code>BACKUP ARCHIVELOG ALL</code>, then RMAN backs up exactly one copy of each distinct log sequence number. For example, if you archive to multiple destinations, RMAN backs up <i>one</i> copy of each log sequence number—not each copy of each log sequence number. For other commands, such as <code>DELETE ALL</code> does refer to every log, even duplicate log sequences.</p> <p>If the database is open when you run <code>BACKUP ARCHIVELOG</code>, and if the <code>UNTIL</code> clause or <code>SEQUENCE</code> parameter is not specified, then RMAN runs <code>ALTER SYSTEM ARCHIVE LOG CURRENT</code>.</p> <p><b>Note:</b> If you run <code>BACKUP ARCHIVELOG ALL</code>, or if the specified log range includes logs from prior incarnations, then RMAN backs up logs from prior incarnations to ensure availability of all logs that may be required for recovery through an <code>OPEN RESETLOGS</code>.</p> <p><b>See Also:</b> <a href="#">archivelogRecordSpecifier</a> for syntax, and <i>Oracle Database Backup and Recovery User's Guide</i> explanations of backup failover for logs and automatic log switching</p>

---

Syntax Element	Description
BACKUPSET	<p>Specifies a backup of backup sets. Use this parameter with the <a href="#">DEVICE TYPE sbt</a> clause to offload backups on disk to tape (as shown in <a href="#">Example 2-21</a>). You cannot back up from tape to tape or from tape to disk: only from disk to disk or disk to tape.</p> <p>If you specify the <a href="#">DELETE INPUT</a> option on the <code>BACKUP BACKUPSET</code> command, then RMAN deletes all copies of the backup set that exist on disk. For example, if you duplexed a backup to 4 locations, then RMAN deletes all 4 backup sets. The <code>ALL</code> option does not add any functionality.</p> <p>RMAN performs <b>backup set failover</b> when backing up backup sets. RMAN searches for all available backup copies when the copy that it is trying to back up is corrupted or missing. This behavior is similar to RMAN's behavior when backing up archived redo log files that exist in multiple archiving destinations.</p> <p>If <b>backup optimization</b> is enabled when you back up a backup set, and if the identical backup set has been backed up to the same device type, then RMAN skips the backup of this backup set.</p> <p>Starting with Oracle Database Release 18c, you can use the <code>BACKUP AS COMPRESSED BACKUPSET</code> command to compress backup sets that were not created using compression.</p> <p>You can use <code>BACKUP ... BACKUPSET</code> to back up unencrypted backup sets in encrypted format. Before running the <code>BACKUP</code> command, enable encryption using the <code>SET ENCRYPTION FOR DATABASE ON</code> command.</p> <p><b>Note:</b> When you use the <code>BACKUP BACKUPSET</code> command with encrypted backup sets, the backup sets are backed up in their encrypted form. Because <code>BACKUP BACKUPSET</code> just copies the encrypted backup set to disk or tape, no decryption key is needed during a <code>BACKUP BACKUPSET</code> operation. The data is never decrypted during any part of the operation. The <code>BACKUP BACKUPSET</code> command can neither encrypt nor decrypt backup sets.</p> <p><b>Note:</b> You can duplex backups of backup sets with <code>BACKUP COPIES</code> and <code>SET BACKUP COPIES</code>.</p>
ALL	<p>Specifies all backup sets.</p> <p>When used with CDBs, RMAN skips backing up the backups of PDBs that were dropped. There is no way to back up backup sets of dropped PDBs.</p>
<a href="#">completedTimeSpec</a>	<p>Identifies backup sets according to completion time.</p> <p><b>See Also:</b> <a href="#">completedTimeSpec</a></p>
<i>integer</i>	<p>Specifies backup sets according to primary key. You can obtain the primary keys for backup sets from the output of the <code>LIST BACKUP</code> command.</p>
FROM TAG <i>tag_name</i>	<p>Identifies one or more backup sets by tag name. If multiple backup sets have the same tag name, then they are all are backed up. The <i>tag_name</i> is not case-sensitive.</p>
CONTROLFILECOPY	<p>Specifies one or more control file copies for backups.</p> <p>A control file copy can be created with the <code>BACKUP AS COPY CURRENT CONTROLFILE</code> command or the <code>SQL ALTER DATABASE BACKUP CONTROLFILE TO '...'</code> command.</p> <p><b>Note:</b> A control file autobackup is not a control file copy.</p>
' <i>filename</i> '	<p>Specifies a control file copy by file name.</p>
ALL	<p>Specifies all control file copies.</p>
LIKE ' <i>string_pattern</i> '	<p>Specifies a control file copy by a file name pattern. The percent sign (%) as a wildcard meaning 0 or more characters; an underscore (_) is a wildcard meaning 1 character.</p>



Syntax Element	Description
<code>copyOfSpec</code>	Makes a backup of previous image copies of data files and possibly control files. <b>See Also:</b> <a href="#">copyOfSpec</a>
<code>CURRENT CONTROLFILE</code>	Specifies the current control file. When backing up as a backup set, RMAN first creates a snapshot control file for read consistency. You can configure the location of the snapshot control file with the <a href="#">CONFIGURE</a> command. In an Oracle Real Application Clusters (Oracle RAC) environment, the following restrictions apply: <ul style="list-style-type: none"> <li>• The snapshot control file location must be on shared storage—that is, storage that is accessible by all Oracle RAC instances.</li> <li>• The destination of an image copy of the current control file must be shared storage.</li> </ul>
<code>APPLICATION ROOT</code> <code>DATABASE app_root_name</code>	Creates a backup of all data files in the application root. Connect to the CDB root as a common user with the <code>SYSDBA</code> or <code>SYSBACKUP</code> privilege. Or, connect to the application root as an application common user with the <code>SYSDBA</code> or <code>SYSBACKUP</code> privilege.
<code>DATABASE</code>	Creates a backup of all data files in the whole database or a single pluggable database (PDB). To back up a CDB, connect to the root as a common user with the <code>SYSDBA</code> or <code>SYSBACKUP</code> privilege. To back up a PDB, connect to the PDB as a common user or local user with the <code>SYSDBA</code> or <code>SYSBACKUP</code> privilege.  If generating a backup set, then RMAN can include only data files and control files: it cannot include archived redo log files.  In an application container, creates a backup of all data files in the application container. This includes the application root and all application PDBs that belong to this application root. Connect to the application root as an application common user with the <code>SYSDBA</code> or <code>SYSBACKUP</code> privilege.  If the <code>backupSpec</code> includes data file 1, and if <a href="#">CONFIGURE CONTROLFILE AUTOBACKUP</a> is <code>OFF</code> , then RMAN automatically includes the control file in the backup. If the instance is started with a server parameter file, then RMAN also includes this parameter file in the backup.  If the <code>backupSpec</code> includes data file 1, and if <a href="#">CONFIGURE CONTROLFILE AUTOBACKUP</a> is <code>ON</code> , then RMAN does <i>not</i> automatically include the control file in the output. Instead, RMAN generates a separate control file autobackup piece. If the instance is started with a server parameter file, then RMAN includes this parameter file in the autobackup piece.  Full database backups are usually either image copies or compressed backup sets. Image copies are more flexible than backup sets for some purposes (such as use in an incrementally updated backups strategy), and compressed backup sets make more efficient use of storage space, if the CPU overhead involved in creating them is tolerable.  <b>Note:</b> To force RMAN to include the current control file in the backup when <code>CONTROLFILE AUTOBACKUP</code> is <code>ON</code> , specify the <a href="#">INCLUDE CURRENT CONTROLFILE</a> clause.  <b>Note:</b> Proxy PDBs are not backed up during a CDB backup.  <b>See Also:</b> The <a href="#">TABLESPACE</a> description to learn about backup behavior when the database includes bigfile tablespaces
<code>DATABASE ROOT</code>	In a CDB, creates a backup of the data files in the root. Connect to the root as a common user with the common <code>SYSDBA</code> or <code>SYSBACKUP</code> privilege.  In an application container, creates a backup of the files in the application root and all application PDBs. Connect to the application root as an application common user with the <code>SYSDBA</code> or <code>SYSBACKUP</code> privilege.  See the previous description of <code>DATABASE</code> .

Syntax Element	Description
PLUGGABLE DATABASE <i>pdb_name</i>	<p>Creates a backup of the data files in one or more PDBs. Specify multiple PDBs using a comma-delimited list. Connect to the root as a common user with the SYSDBA or SYSBACKUP privilege.</p> <p>With application containers, use this clause as follows:</p> <ul style="list-style-type: none"> <li>To back up one or more application PDBs, connect to the application root as an application common user with the SYSDBA or SYSBACKUP privilege. Use a comma-delimited list to specify multiple application PDBs.</li> <li>To back up the application root and all application PDBs, connect to the CDB root as a common user with the SYSDBA or SYSBACKUP privilege and specify the application root name as <i>pdb_name</i>.</li> </ul> <p><b>Note:</b> Backing up a proxy PDB is not supported</p>
<a href="#">datafileCopySpec</a>	<p>Specifies the file names of one or more data file image copies.</p> <p><b>See Also:</b> <a href="#">datafileCopySpec</a> for details</p>
DATAFILE <a href="#">datafileSpec</a>	<p>Specifies a list of one or more data files. Refer to description of BACKUP DATABASE for RMAN behavior when data file 1 is backed up.</p> <p><b>See Also:</b> <a href="#">datafileSpec</a></p>
DATAPUMP	<p>Specifies that a Data Pump export dump file is created while performing a cross-platform tablespace backup.</p> <p>The export dump file contains the metadata of the read-only tablespaces being transported. You need this metadata to plug in the tablespaces at the destination database. The dump file is created in a separate backup set. If you use the DATAPUMP clause with the INCREMENTAL FROM SCN, then the tablespace must be in read-only mode.</p> <p>This clause cannot be used with the ALLOW INCONSISTENT clause.</p>
FORMAT <a href="#">formatSpec</a>	<p>Specifies the pattern used to store the backup piece that contains the export dump file. If the FORMAT is omitted, then the format provided in the BACKUP command is used. If no FORMAT clause was used for the BACKUP command too, the default format is used for the backup pieces.</p>
SKIP DATAFILES	<p>Excludes data files for backup.</p>
EXCLUDE	<p>Excludes statistics from the data pump export operation.</p> <p>To avoid creating large memory demands, you can choose to exclude statistics data in the export dump file. Use any or all of the following keywords to specify the criteria for EXCLUDE:</p> <ul style="list-style-type: none"> <li>STATISTICS</li> <li>TABLE STATISTICS</li> <li>INDEX STATISTICS</li> </ul>
STATISTICS	<p>Excludes statistics while creating the export dump file.</p>
TABLE STATISTICS	<p>Excludes table statistics while creating the export dump file.</p>
INDEX STATISTICS	<p>Excludes index statistics while creating the export dump file.</p>

Syntax Element	Description
RECOVERY AREA	<p>Backs up recovery files created in the current and all previous fast recovery area destinations. Backups can go to SBT and disk. To backup to disk, you must use the <code>TO DESTINATION</code> syntax outlined in <a href="#">toDestSpec</a>.</p> <p>Recovery files are full and incremental backup sets, control file autobackups, data file copies, and archived redo log files. If an archived redo log file is missing or corrupted, then RMAN looks outside of the recovery area for a good copy of the log that it can use for the backup. Flashback logs, the current control file, and online redo log files are <i>not</i> backed up.</p> <p>By default, backup optimization is enabled for this command even if the <a href="#">CONFIGURE BACKUP OPTIMIZATION</a> setting is <code>OFF</code>. You can disable backup optimization for <code>BACKUP RECOVERY AREA</code> by specifying <code>FORCE</code>.</p> <p><b>Note:</b> If the fast recovery area is not enabled but was enabled previously, then files created in the previous fast recovery area location are backed up.</p>
DB_RECOVERY_FILE_DEST	<p><code>RECOVERY AREA</code> and <code>DB_RECOVERY_FILE_DEST</code> are synonyms.</p>
RECOVERY FILES	<p>Backs up <i>all</i> recovery files on disk, whether they are stored in the fast recovery area or other locations on disk. The backups can go to SBT or disk. To backup to disk, you must use the <code>TO DESTINATION</code> syntax outlined in <a href="#">toDestSpec</a>.</p> <p>Recovery files include full and incremental backup sets, control file autobackups, archived redo log files, and data file copies.</p> <p>By default, backup optimization is enabled for this command even if the <a href="#">CONFIGURE BACKUP OPTIMIZATION</a> setting is <code>OFF</code>. You can disable backup optimization for <code>RECOVERY FILES</code> by specifying <code>FORCE</code>.</p>
SPFILE	<p>Includes the server parameter file in a backup set. The <code>AS COPY</code> option is not supported for server parameter file backups.</p> <p>RMAN backs up the server parameter file currently in use by the target database. RMAN cannot back up the server parameter file when the instance was started with an initialization parameter file. RMAN cannot make incremental backups of the <code>SPFILE</code>.</p>
TABLESPACE <i>tablespace_name</i>	<p>Specifies the names of one or more tablespaces. RMAN translates tablespace names internally into a list of data files, then backs up all data files that are currently part of the tablespaces. If the <code>SYSTEM</code> tablespace (and thus data file 1) is included in the backup, and if <a href="#">CONTROLFILE AUTOBACKUP</a> is not configured, then RMAN also creates a copy of the control file.</p> <p>When connected to the root in a CDB, refers to tablespaces in the root. Refers to tablespaces in a PDB when connected directly to a PDB.</p> <p>You cannot back up locally-managed temporary tablespaces, although you can back up dictionary-managed tablespaces.</p> <p>If the following conditions are met, then RMAN can back up transportable tablespaces that have <i>not</i> been made read/write after being transported:</p> <ul style="list-style-type: none"> <li>• The <code>COMPATIBLE</code> initialization parameter is set to 11.0.0 or higher.</li> <li>• You are using an Oracle Database 11g or later RMAN client.</li> </ul> <p>If any of the preceding conditions is not met, then RMAN automatically skips transportable tablespaces that have not yet been made read/write. If you specify a transportable tablespace explicitly when any of the conditions is not met, then RMAN issues an error saying that the tablespace does not exist.</p> <p><b>Note:</b> If you rename a tablespace, then RMAN detects that the tablespace has changed its name and updates the recovery catalog on the next resynchronization.</p>
<a href="#">backupSpecOperand</a>	<p>The <a href="#">backupSpecOperand</a> that follows a <a href="#">backupSpec</a> specifies options that apply to the <a href="#">backupSpec</a>.</p>

**backupSpecOperand**

This subclause specifies a variety of options and parameters that affect the `backupSpec` clause. Many subclauses are also used with `backupOperand`. Options that are not shared in common with `backupOperand` are listed here. Refer to `backupSpecOperand::=` for the syntax diagram.

Syntax Element	Description
<code>DELETE [ALL] INPUT</code>	<p>Deletes the input files after successfully backing them up.</p> <p>Specify this option only when backing up archived redo log files, data file copies (<code>COPY OF</code> or <code>DATAFILECOPY</code>), or backup sets. The <code>BACKUP ARCHIVELOG</code> command only backs up one copy of each distinct log sequence number, so if the <code>DELETE INPUT</code> option is used <i>without</i> the <code>ALL</code> keyword, RMAN only deletes the copy of the file that it backs up.</p> <p>Specifying the <code>DELETE INPUT</code> option is equivalent to issuing the <code>DELETE</code> command for the input files. When backing up archived redo log files, RMAN uses the configured settings to determine whether an archived redo log can be deleted (<code>CONFIGURE ARCHIVELOG DELETION POLICY TO BACKED UP</code>).</p> <p>The <code>ALL</code> option applies only to archived redo log files. If you run <code>DELETE ALL INPUT</code>, then the command deletes all copies of corresponding archived redo log files or data file copies that match the selection criteria in the <code>BACKUP</code> command (as shown in <a href="#">Example 2-19</a>). For example, if you specify the <code>SEQUENCE n</code> clause, then RMAN deletes all archived redo log files with same sequence number <code>n</code>.</p> <p><b>Note:</b> The database retains archived redo log files in the fast recovery area if possible and deletes them automatically when disk space is required. You can use the <code>BACKUP DELETE INPUT</code>, <code>DELETE ARCHIVELOG</code>, and <code>DELETE OBSOLETE</code> commands to delete log files manually from inside or outside the recovery area. You do not need to specify <code>BACKUP DELETE INPUT</code> when backing up the recovery area because the database automatically deletes log files based on the archived redo log deletion policy and other fast recovery area rules.</p>
<code>FROM TAG tag_name</code>	<p>Identifies files by tag name (see <a href="#">Example 2-18</a>). Only the files that match the <code>tag_name</code> are backed up. Defined in context with several other commands.</p>
<code>INCLUDE CURRENT CONTROLFILE</code>	<p>Creates a snapshot of the current control file and places it into one of backup sets produced by the <code>BACKUP</code> command.</p> <p><b>Note:</b> This option does not apply with <code>AS COPY</code> and results in an error message.</p>

**backupTypeSpec**

This subclause specifies the form of the `BACKUP` command output: backup set or image copy. Refer to `backupTypeSpec::=` for the syntax diagram.

Syntax Element	Description
AS BACKUPSET	<p>Creates backup sets on the specified device. This is the default backup type.</p> <p>AS BACKUPSET is the only possibility when backing up to tape, and for creating level 1 incremental backups to any destination. Backup sets are RMAN-specific logical structures. The backup set is the smallest unit of a backup.</p> <p>The <b>FILESERSET</b> parameter of the <b>BACKUP</b> command determines the maximum number of files in each backup set. Archived redo log files and data files are never combined into a single backup set.</p> <p>When using encrypted backups, data files from tablespaces with different encryption settings are never written into the same backup set.</p> <p>RMAN cannot back up files with different block sizes into the same backup set. RMAN can back up tablespaces with different block sizes, but puts each differently sized data file into its own backup set.</p> <p>When <b>unused block compression</b> is applied, RMAN reads only the blocks that are currently allocated to a table. RMAN still checks each of the blocks to see whether the header has marked the block as unused. If a block has been unused, it is not written to the backup.</p> <p>Unused block compression is turned on automatically when all of the following five conditions are true:</p> <ol style="list-style-type: none"><li>1. The <b>COMPATIBLE</b> initialization parameter is set to 10.2 or higher. <b>Note:</b> If <b>COMPATIBLE</b> is set to 10.2, then only tablespaces created with 10.2 compatibility are optimized to exclude blocks that do not currently contain data. If <b>COMPATIBLE</b> is set to 11.0.0 or higher, however, then the first backup that produces backup sets after <b>COMPATIBLE</b> is set to 11.0.0 or higher updates the headers of all locally managed data files so that all locally managed data files can be optimized.</li><li>2. There are currently no guaranteed restore points defined for the database.</li><li>3. The data file is locally managed</li><li>4. The data file is being backed up to a backup set as part of a full backup or a level 0 incremental backup</li><li>5. The backup set is created on disk or Oracle Secure Backup is the media manager. <b>Note:</b> When backing up to a media manager that is not Oracle Secure Backup, RMAN copies all the blocks regardless of whether they contain data or not.</li></ol> <p><b>Note:</b> A corrupt unused block is not harmful. This is because when a block is corrupt and RMAN does not read it because of unused block compression, RMAN does not detect the corruption.</p> <p>Each backup set contains at least one <b>backup piece</b>, which is an RMAN-specific physical file containing the backed up data. You can also use the <b>BACKUP</b> command to generate a <b>proxy copy</b>, which is a backup in which the entire data transfer is conducted by a media manager.</p> <p>RMAN only records complete backup sets in the RMAN repository. There are no partial backup sets. When a <b>BACKUP</b> command creates backup pieces but does not produce a complete backup set, the backup pieces are discarded.</p> <p><b>Note:</b> You cannot stripe a single backup set across multiple channels. You also cannot stripe a single input file across multiple backup sets.</p> <p><b>See Also:</b> <i>Oracle Secure Backup Administrator's Guide</i> to learn how to use Oracle Secure Backup with RMAN</p>

Syntax Element	Description
AS COMPRESSED BACKUPSET	<p>Enables binary compression.</p> <p>RMAN compresses the data written into the backup set to reduce the overall size of the backup set. All backups that create backup sets can create compressed backup sets. Restoring compressed backup sets is no different from restoring uncompressed backup sets.</p> <p>RMAN applies a binary compression algorithm as it writes data to backup sets. This compression is similar to the compression provided by many media manager vendors. When backing up to a <i>locally attached</i> tape device, compression provided by the media management vendor is usually preferable to the binary compression provided by <code>BACKUP AS COMPRESSED BACKUPSET</code>. Therefore, use uncompressed backup sets and turn on the compression provided by the media management vendor when backing up to locally attached tape devices. Do not use RMAN binary compression and media manager compression together.</p> <p>Some CPU overhead is associated with compressing backup sets. If the target database is running at or near its maximum load, then you may find the overhead unacceptable. In most other circumstances, compressing backup sets saves enough disk space to be worth the CPU overhead.</p>
AS COPY	<p>Creates image copies (rather than backup sets).</p> <p>An image copy is a byte-for-byte identical copy of the original file. You can create image copy backups of data files, control files, data file copies, control file copies, and archived redo log files. Image copy files can only exist on disk. When using incrementally updated backups, the level 0 incremental must be an image copy backup.</p> <p>By default, <code>BACKUP</code> generates backup sets. You can change the default backup type for disk backups to image copies using the <code>CONFIGURE DEVICE TYPE ... BACKUP TYPE TO COPY</code> command.</p> <p>RMAN chooses a location for the copy according to the following rules, listed in order of precedence:</p> <ol style="list-style-type: none"> <li>1. <code>FORMAT</code> specified on <code>BACKUP</code> command for the object being backed up</li> <li>2. <code>FORMAT</code> specified for the <code>BACKUP</code> command</li> <li>3. <code>fileNameConversionSpec</code> setting for <code>BACKUP</code> command</li> <li>4. <code>CONFIGURE CHANNEL integer ... FORMAT</code></li> <li>5. <code>CONFIGURE CHANNEL DEVICE TYPE ... FORMAT</code></li> <li>6. Platform-specific default <code>FORMAT</code> (which includes a <code>%U</code> for generating a unique file name)</li> </ol> <p>You can create and restore image copy backups with RMAN or use a native operating system command for copying files. When you use RMAN, copies are recorded in the RMAN repository and are more easily available for use in restore and recovery. Otherwise, you must use the <code>CATALOG</code> command to add the user-managed copies to the RMAN repository so that RMAN can use them.</p> <p>You cannot make a copy of a backup set, although you can make an image copy of an image copy. To back up a backup set, use <code>BACKUP BACKUPSET</code>.</p>

Syntax Element	Description
AS SPARSE BACKUPSET	<p>Creates sparse backups of sparse data files in the backup set format. To use this clause, the <code>COMPATIBLE</code> initialization parameter of the database being backed up must be set to 12.2 or higher.</p> <p>If you run this command on a non-sparse database, then RMAN performs a traditional backup in the backup set format.</p> <p>This setting overrides the default device type parameter set using the <a href="#">CONFIGURE</a> command.</p> <p>See the <code>AS BACKUPSET</code> clause for more information on the backup set format.</p>
AS NONSPARSE BACKUPSET	<p>Creates traditional (non-sparse) backups of data files in a sparse environment, in the backup set format. The source data files can be sparse and non-sparse. To use this clause, the <code>COMPATIBLE</code> initialization parameter of the database being backed up must be set to 12.2 or higher.</p> <p>See the <code>AS BACKUPSET</code> clause for more information on the backup set format.</p>
AS SPARSE COMPRESSED BACKUPSET	<p>Creates sparse backups of sparse data files in the compressed backup set format. To use this clause, the <code>COMPATIBLE</code> initialization parameter of the database must be set to 12.2 or higher.</p> <p>If you run this command on a non-sparse database, then RMAN performs a traditional backup in the compressed backup set format.</p> <p>This setting overrides the default device type parameter set using the <a href="#">CONFIGURE</a> command.</p> <p>See the <code>AS COMPRESSED BACKUPSET</code> clause for more information on the compressed backup set format.</p>
AS NONSPARSE COMPRESSED BACKUPSET	<p>Creates traditional (non-sparse) backups of data files in a sparse environment, in the compressed backup set format. The source data files can be sparse and non-sparse. To use this clause, the <code>COMPATIBLE</code> initialization parameter of the database must be set to 12.2 or higher.</p> <p>See the <code>AS COMPRESSED BACKUPSET</code> clause for more information on the compressed backup set format.</p>
AS SPARSE COPY	<p>Creates sparse backups of sparse data files in the image copy format. To use this clause, the <code>COMPATIBLE</code> initialization parameter of the database must be set to 12.2 or higher.</p> <p>If you run this command on a non-sparse database, then RMAN performs a traditional full backup in the image copy format.</p> <p>This setting overrides the default device type parameter set using the <a href="#">CONFIGURE</a> command.</p> <p>See the <code>AS COPY</code> clause for more information on the image copy format.</p>
AS NONSPARSE COPY	<p>Creates traditional (non-sparse) backups of data files in a sparse environment in the image copy format. The source data files can be sparse and non-sparse. To use this clause, the <code>COMPATIBLE</code> initialization parameter of the database must be set to 12.2 or higher.</p> <p>See the <code>AS COPY</code> clause for more information on the image copy format.</p>

### *copyOfSpec*

This subclause specifies the form of the `BACKUP` command output: backup set or image copy. Refer to [copyOfSpec::=](#) for the syntax diagram.

Syntax Element	Description
<code>COPY OF DATABASE</code>	<p>Makes a backup of previous image copies of all data files and control files in the database. All data files that would normally be included by <code>BACKUP DATABASE</code> are expected to have copies: if not, RMAN signals an error. It is not necessary for all copies to have been produced by a single <code>BACKUP</code> command. If multiple copies exist of data file, then RMAN backs up the latest. Optionally, specify the copies by tag name (for example, <code>FULL_COLD_COPY</code>).</p> <p>In a CDB, creates a backup of previous image copies of all data files and control files in the CDB. You connect to the root to back up the whole CDB. In a PDB, creates a backup of previous image copies of all data files and control files in the PDB. To backup a PDB, connect to that PDB.</p> <p><b>Note:</b> The output of this command can be image copies or backup sets.</p>
<code>COPY OF DATABASE ROOT</code>	<p>In a CDB, makes a backup of previous image copies of the data files and control files in the root. See the previous description of <code>COPY OF DATABASE</code>.</p>
<code>COPY OF PLUGGABLE DATABASE <i>pdb_name</i></code>	<p>In a CDB, makes a backup of previous image copies of the data files and controls files in one or more PDBs. Use a comma-delimited list to specify multiple PDBs and connect to the root.</p>
<code>COPY OF DATAFILE <i>datafileSpec</i></code>	<p>Makes a backup of a previous image copy of one or more data files. Specify the data file by file number (<code>DATAFILE 3</code>) or file name (<code>DATAFILE '?/oradata/trgt/users01.dbf'</code>). You specify the data file name and <i>not</i> the file name of the copy of the data file. If multiple copies of a data file exist, then RMAN backs up the most recent copy.</p> <p><b>Note:</b> It is not necessary for the image copies that you are backing up to have been created by a single <code>BACKUP</code> command.</p> <p><b>Note:</b> The output of this command can be image copies or backup sets.</p> <p><b>See Also:</b> <a href="#">datafileSpec</a></p>
<code>COPY OF TABLESPACE <i>tablespace_name</i></code>	<p>Makes a backup of previous image copies of the data files in one or more specified tablespaces. All data files that are normally included by <code>BACKUP TABLESPACE</code> should have copies: if not, then RMAN signals an error. It is not necessary for all copies to have been produced by a single <code>BACKUP</code> command. If multiple copies exist of data file, then RMAN backs up the latest.</p> <p>Specify the tablespaces in the list by tablespace name (for example, <code>users</code>) or specify a particular copy by tag name (for example, <code>0403_CPY_OF_USERS</code>). If you do not specify <code>TAG</code>, then RMAN backs up the most recent data file copy for each data file in the tablespace.</p> <p><b>Note:</b> The output of this command can be image copies or backup sets.</p>

### ***datafileCopySpec***

This subclause specifies data file copies. Refer to [datafileCopySpec::=](#) for the syntax diagram.

Syntax Element	Description
<code>'filename'</code>	Specifies the file names of one or more data file image copies.
<code>ALL</code>	Specifies all data file image copies for back up.
	When used with CDBs, RMAN skips backing up all copies of PDBs that were dropped.
<code>LIKE 'string_pattern'</code>	Specifies a file name pattern. The percent sign (%) is a wildcard that means zero or more characters; an underscore (_) is a wildcard that means one character.



Syntax Element	Description
FROM TAG <i>tag_name</i>	Specifies a list of one or more data file copies, identified by the tag name. If multiple data file copies with this tag exist, then RMAN backs up only the most current data file copy of any particular data file. Tags are not case sensitive.
NODUPLICATES	Prevents the inclusion of identical data file copies in a backup operation (Example 2-29). For each set of duplicate data file copies, the file with the most recent timestamp is selected.

### ***duration***

This subclause specifies data file copies. Refer to [duration::=](#) for the syntax diagram.

Syntax Element	Description
DURATION <i>hh:mm</i>	Specifies a maximum time for a backup command to run. If a backup command does not complete in the specified duration, then the backup stops. Without the PARTIAL option, the backup command is considered to have failed if it does not complete in the specified duration, and RMAN reports an error. If the backup command is part of a RUN block, then subsequent commands in the RUN block do not execute.
MINIMIZE {LOAD   TIME}	With disk backups, you can use MINIMIZE TIME run the backup at maximum speed (default), or MINIMIZE LOAD to slow the rate of backup to lessen the load on the system. With MINIMIZE LOAD the backup takes the full specified duration. If you specify TIME, then file most recently backed up is given the lowest priority to back up. This scheduling mechanism provides for the eventual complete backup of the database during successive backup windows, as different data files are backed up in round-robin fashion.
PARTIAL	With the PARTIAL option, the command is considered to have completed successfully and no error is reported by RMAN even if the whole backup is not completed in the specified duration. Without the PARTIAL option, the backup command is considered to have failed if it does not complete in the specified duration, and RMAN reports an error. If the backup command is part of a RUN block, then subsequent commands in the RUN block do not execute. Whether PARTIAL is used or not, all backup sets completed before the backup is interrupted are retained and can be used in RESTORE and RECOVER operations.

### ***forRecoveryOfSpec***

This subclause specifies a backup for use in an incrementally updated backup strategy. You must specify INCREMENTAL LEVEL 1 when specifying FOR RECOVER OF. Refer to [forRecoveryOfSpec::=](#) for the syntax diagram.

Syntax Element	Description
FOR RECOVER OF COPY	<p>Specifies that this incremental backup contains all changes since a previous data file copy or incremental backup. By default, RMAN creates a differential incremental backup. You must specify <code>CUMULATIVE</code> to force RMAN to create cumulative backups.</p> <p>Use the <code>WITH TAG</code> clause to separate this incremental backup strategy from the rest of your backup strategies. If you do <i>not</i> specify <code>WITH TAG</code>, then RMAN uses the most recent data file copy as the basis for the incremental backup.</p> <p>A <code>BACKUP INCREMENTAL LEVEL 1 FOR RECOVER OF COPY</code> command can create image copies or backup sets. RMAN creates level 0 image copies if no such copies exist, but otherwise creates backup sets.</p> <p><b>See Also:</b> <i>Oracle Database Backup and Recovery User's Guide</i> to learn how to make incrementally updated backups</p>
WITH TAG <i>tag_name</i>	<p>Specifies the tag of the level 0 incremental backup serving as the basis of the backup strategy (see <a href="#">Example 2-20</a>).</p> <p>By using the <code>BACKUP INCREMENTAL . . . WITH TAG</code> syntax, you can create level 1 incremental backups suitable for rolling forward a level 0 image copy. You can then use <code>RECOVER COPY OF . . . WITH TAG</code> to apply level 1 backups to this copy. In this way, the strategy continues to roll forward the data file copy so that media recovery does not need to apply as many changes. This technique is the basis for the Enterprise Manager strategy for disk backups.</p> <p>When <code>WITH TAG</code> is specified, RMAN automatically assigns all new incremental backups in the strategy the same tag as the level 0 data file copy. RMAN decides which blocks to include in the level 1 backup based on the available incremental backups that have this tag.</p> <p><b>Note:</b> If the <code>BACKUP</code> command has both the <code>TAG</code> and <code>WITH TAG</code> options, then RMAN issues a warning stating that the <code>TAG</code> option is ignored and that incremental backups receive the tag specified by <code>WITH TAG</code>.</p> <p>If no level 0 backup with the tag specified in the <code>WITH TAG</code> parameter exists in either the current or parent database incarnation, then <code>FOR RECOVER OF COPY</code> option creates a level 0 data file copy tagged with the value specified in the <code>WITH TAG</code> parameter.</p>
DATAFILECOPY FORMAT <i>formatSpec</i>	<p>Specifies a pattern for naming the output image copies.</p> <p>If you add a data file to the database, then you do not need to change the backup script because RMAN automatically creates the level 0 data file copy required by the incrementally updated backup strategy for the newly created file.</p>
FOR RECOVER OF TAG <i>tag_name</i>	<p>Backs up the archived redo log files or incremental backups that are intended to recover the level 0 incremental backup specified by <i>tag_name</i>.</p> <p>For example, the <code>BACKUP INCREMENTAL LEVEL 1 FOR RECOVER OF TAG wholedb ARCHIVELOG ALL</code> command backs up all archived redo log files needed to recover the level 0 incremental backup tagged <code>wholedb</code>.</p>

### ***notBackedUpSpec***

This subclause specifies that RMAN only backs up files that have not yet been backed up to the same device type. Refer to `notBackedUpSpec::=` for the syntax diagram.

Syntax Element	Description
NOT BACKED UP	<p>Backs up only those files—of the files specified on the <code>BACKUP</code> command—that RMAN has never backed up for the same device type (see <a href="#">Example 2-28</a>).</p> <p>This subclause is a convenient way to back up new data files after adding them to the database. RMAN does not examine data file checkpoints, but backs up any data file that is not already backed up. You can also specify <code>NOT BACKED UP</code> when backing up backup sets.</p> <p>Using <code>BACKUP</code> with this clause does manually what an archived redo log deletion policy can do automatically. If you specify the <code>CONFIGURE ARCHIVELOG DELETION POLICY TO BACKED UP integer TIMES</code> command, then a <code>BACKUP ARCHIVELOG ALL</code> command copies all logs unless <i>integer</i> backups exist on the specified device type. If <i>integer</i> backups of the logs exist, then the <code>BACKUP</code> command skips the logs. In this way, the archived log deletion policy functions as a default <code>NOT BACKED UP integer TIMES</code> clause on the <code>BACKUP</code> command.</p> <p>Archival backups created with the <code>KEEP</code> option are not counted when evaluating the <code>NOT BACKED UP</code> subclause. For example, if you issue the command</p> <pre>BACKUP ARCHIVELOG SEQUENCE 345 NOT BACKED UP 3 TIMES</pre> <p>and the specified log is already backed up into two non-<code>KEEP</code> backup sets and one <code>KEEP</code> backup set, then that command backs up the log one more time.</p> <p><b>Note:</b> This clause overrides backup optimization (<code>CONFIGURE BACKUP OPTIMIZATION</code>) and archived redo log file deletion policies (<code>CONFIGURE ARCHIVELOG DELETION POLICY</code>).</p>
AT ANY SCN	<p>Backs up only those data files that have not been backed up at any SCN.</p> <p>This option is a convenient way to back up only the new data files. When you use the <code>BACKUP DATAFILECOPY ALL</code> command to back up disk backups that are part of an incrementally updated backup strategy to tape or Oracle Cloud, using the <code>SINCE TIME</code> clause also backs up data files that are already backed up. Use <code>AT ANY SCN</code> to only back up new data files that have never been backed up.</p>
<i>integer</i> TIMES	<p>Backs up only those archived redo log files that have not been backed up at least <i>integer</i> times.</p> <p><b>Note:</b> You can only specify <code>NOT BACKED UP integer TIMES</code> when backing up archived redo log files into backup sets.</p> <p>To determine the number of backups for a file, RMAN only considers backups created on the same device type as the current backup.</p> <p>This option is a convenient way to back up archived redo log files on a specified media. For example, you want to keep at least three copies of each log on tape.</p>

Syntax Element	Description
<code>SINCE TIME 'date_string'</code>	<p>Specifies the date after which RMAN backs up files that have no backups. The <i>date_string</i> is either a date in the current <code>NLS_DATE_FORMAT</code> or a SQL date expression such as <code>'SYSDATE-1'</code>. When calculating the number of backups for a file, RMAN only considers backups created on the same device type as the current backup.</p> <p>This option is a convenient way to back up data files that were not backed up during a previous failed backup. For example, you back up the database, but the instance fails halfway through. You can restart the backup with the <code>NOT BACKED UP SINCE TIME</code> clause and avoid backing up those files that are already backed up. If <a href="#">AS BACKUPSET</a> is specified, then this feature is only useful if RMAN generates multiple backup sets during the backup.</p> <p>When determining whether a file has been backed up, the <code>SINCE</code> date is compared with the completion time of the most recent backup. For <code>BACKUP AS BACKUPSET</code>, the completion time for a file in a backup set is the completion time of the entire backup set. In other words, all files in the same backup set have the same completion time.</p>

### *skipSpec*

This subclause specifies which files to exclude from the backup. Refer to [skipSpec::=](#) for the syntax diagram.

Syntax Element	Description
<code>SKIP</code>	<p>Excludes data files or archived redo log files according to the criteria specified by the following keywords.</p> <p><b>Note:</b> You can also specify this option in the <a href="#">backupSpec</a> clause.</p>
<code>INACCESSIBLE</code>	<p>Excludes data files or archived redo log files that cannot be read due to I/O errors.</p> <p>A data file is only considered inaccessible if it cannot be read. Some offline data files can still be read because they still exist on disk. Others have been deleted or moved and so cannot be read, making them inaccessible.</p>
<code>OFFLINE</code>	Excludes offline data files.
<code>READONLY</code>	Excludes read-only data files.

### Examples

#### Example 2-13 Backing Up a Database

This example starts the RMAN client from the operating system command line and then connects to a target database using operating system authentication. The `BACKUP` command backs up all data files, the current control file, the server parameter file, and archived redo log files to the default storage device:

```
% rman
RMAN> CONNECT TARGET /
RMAN> BACKUP DATABASE PLUS ARCHIVELOG;
```

#### Example 2-14 Backing Up a Sparse Database

This example uses the `BACKUP` command to backup a sparse database in the backup set format and the archive log.

```
RMAN> BACKUP AS SPARSE BACKUPSET DATABASE PLUS ARCHIVELOG;
```

### Example 2-15 Backing Up Multiple PDBs

This example connects to the root using operating system authentication and then creates backups of the PDBs `hr_pdb` and `sales_pdb`.

```
%rman
RMAN> CONNECT TARGET /
RMAN> BACKUP PLUGGABLE DATABASE hr_pdb, sales_pdb;
```

### Example 2-16 Performing a Cumulative Incremental Backup

This example backs up all blocks changed in the database since the most recent level 0 incremental backup. If no level 0 backup exists when you run a level 1 backup, then RMAN makes a level 0 backup automatically. Any inaccessible files are skipped.

```
BACKUP
  INCREMENTAL LEVEL 1 CUMULATIVE
  SKIP INACCESSIBLE
  DATABASE;
```

### Example 2-17 Distributing a Backup Across Multiple Disks

This example backs up tablespaces to two different disks and lets RMAN perform automatic parallelization of the backup. The `%U` in the `FORMAT` string is a substitution variable that generates a unique file name for each output image copy.

```
RUN
{
  ALLOCATE CHANNEL dev1 DEVICE TYPE DISK FORMAT '/disk1/%U';
  ALLOCATE CHANNEL dev2 DEVICE TYPE DISK FORMAT '/disk2/%U';
  BACKUP AS COPY
    TABLESPACE SYSTEM, tools, users, undotbs;
}
```

### Example 2-18 Identifying Data File Copies by Tag

In this example, you back up data file image copies to tape. The `BACKUP` command locates all data file copies with the tag `LATESTCOPY`, backs them up to tape, and names the backups using substitution variables. The variable `%f` specifies the absolute file number, whereas `%d` specifies the name of the database. After the data file copies are on tape, the example deletes all image copies with the tag `LATESTCOPY`.

```
BACKUP
  DEVICE TYPE sbt
  DATAFILECOPY
  FROM TAG 'LATESTCOPY'
  FORMAT 'Datafile%f_Database%d';
DELETE COPY TAG 'LATESTCOPY';
```

### Example 2-19 Backing Up and Deleting Archived Redo Log Files

This example assumes that you have two archiving destinations set: `/disk2/PROD/archive/` and `/disk1/arch/`. The command backs up one archived redo log for each unique sequence number. For example, if archived redo log 1000 is in both directories, then RMAN only backs up one copy of this log. The `DELETE INPUT` clause with the `ALL` keyword deletes all archived redo log files from both archiving directories after the backup.

```
BACKUP DEVICE TYPE sbt
  ARCHIVELOG LIKE '/disk%arc%'
  DELETE ALL INPUT;
```

Sample output for the preceding command appears as follows:

```

Starting backup at 12-MAR-13
allocated channel: ORA_SBT_TAPE_1
channel ORA_SBT_TAPE_1: SID=150 device type=SBT_TAPE
channel ORA_SBT_TAPE_1: Oracle Secure Backup
channel ORA_SBT_TAPE_1: starting archived log backup set
channel ORA_SBT_TAPE_1: specifying archived log(s) in backup set
input archived log thread=1 sequence=4 RECID=4 STAMP=616789551
input archived log thread=1 sequence=5 RECID=5 STAMP=616789551
input archived log thread=1 sequence=6 RECID=6 STAMP=616789554
input archived log thread=1 sequence=7 RECID=7 STAMP=616789731
input archived log thread=1 sequence=8 RECID=8 STAMP=616789825
input archived log thread=1 sequence=9 RECID=10 STAMP=616789901
input archived log thread=1 sequence=10 RECID=12 STAMP=616789985
channel ORA_SBT_TAPE_1: starting piece 1 at 12-MAR-13
channel ORA_SBT_TAPE_1: finished piece 1 at 12-MAR-13
piece handle=0vice0g7_1_1 tag=TAG20130312T105917 comment=API Version 2.0,MMS Version 10.1.0.3
channel ORA_SBT_TAPE_1: backup set complete, elapsed time: 00:00:25
channel ORA_SBT_TAPE_1: deleting archived log(s)
archived log file name=/disk2/PROD/archivelog/2013_03_09/oi_mf_1_4_2z45sgrc_.arc RECID=4
STAMP=616789551
archived log file name=/disk2/PROD/archivelog/2013_03_09/oi_mf_1_5_2z45sgrc_.arc RECID=5
STAMP=616789551
archived log file name=/disk2/PROD/archivelog/2013_03_09/oi_mf_1_6_2z45s13g_.arc RECID=6
STAMP=616789554
archived log file name=/disk2/PROD/archivelog/2013_03_09/oi_mf_1_7_2z45z2kt_.arc RECID=7
STAMP=616789731
archived log file name=/disk2/PROD/archivelog/2013_03_09/oi_mf_1_8_2z4620sk_.arc RECID=8
STAMP=616789825
archived log file name=/disk1/arch/archiver_1_8_616789153.arc RECID=9 STAMP=616789825
archived log file name=/disk2/PROD/archivelog/2013_03_09/oi_mf_1_9_2z464dhk_.arc RECID=10
STAMP=616789901
archived log file name=/disk1/arch/archiver_1_9_616789153.arc RECID=11 STAMP=616789901
archived log file name=/disk2/PROD/archivelog/2013_03_09/oi_mf_1_10_2z4670gr_.arc RECID=12
STAMP=616789985
archived log file name=/disk1/arch/archiver_1_10_616789153.arc RECID=13 STAMP=616789985
Finished backup at 12-MAR-13

Starting Control File and SPFILE Autobackup at 12-MAR-13
piece handle=c-28643857-20130312-02 comment=API Version 2.0,MMS Version 10.1.0.3
Finished Control File and SPFILE Autobackup at 12-MAR-13

```

### Example 2-20 Scripting Incrementally Updated Backups

By incrementally updating backups, you can avoid the overhead of making full image copy backups of data files, while also minimizing media recovery time. For example, if you run a daily backup script, then you never have more than one day of redo to apply for media recovery.

Assume you run the following script daily. On first execution, the script creates an image copy backup of the database on disk with the specified tag. On second execution, the script creates a level 1 differential incremental backup of the database. On every subsequent execution, RMAN applies the level 1 incremental backup to the data file copy and then makes a new level 1 backup.

```

RUN
{
  RECOVER COPY OF DATABASE
  WITH TAG 'incr_update';
  BACKUP
  INCREMENTAL LEVEL 1
  FOR RECOVER OF COPY WITH TAG 'incr_update'
  DATABASE;
}

```

### Example 2-21 Backing Up Disk-Based Backup Sets to Tape

Assume your goal is to keep recent backup sets on disk and older backup sets on tape. Also, you want to avoid keeping copies of the same backup set on disk and tape simultaneously. This example backs up backup sets created more than two weeks ago to tape and then deletes the backup pieces from disk.

```
BACKUP
  DEVICE TYPE sbt
  BACKUPSET
    COMPLETED BEFORE 'SYSDATE-14'
  DELETE INPUT;
```

### Example 2-22 Duplexing a Database Backup

This example uses the **COPIES** parameter to create two compressed backups of the database, with each backup on a separate disk. The output locations are specified in the **FORMAT** parameter.

```
BACKUP AS COMPRESSED BACKUPSET
  DEVICE TYPE DISK
  COPIES 2
  DATABASE
  FORMAT '/disk1/db_%U', '/disk2/db_%U';
```

### Example 2-23 Specifying How Channels Divide Workload

This example explicitly parallelizes a backup by using the **CHANNEL** parameter to specify which channels back up which files and to which locations.

```
RUN
{
  ALLOCATE CHANNEL ch1 DEVICE TYPE sbt
    PARMS 'ENV=(OB_DEVICE_1=stape1)';
  ALLOCATE CHANNEL ch2 DEVICE TYPE sbt
    PARMS 'ENV=(OB_DEVICE_1=stape2)';
  BACKUP
    (DATABASE          # ch1 backs up database to tape drive stape1
      CHANNEL ch1)
    (ARCHIVELOG ALL
      CHANNEL ch2); # ch2 backs up archived redo log files to tape drive stape2
}
```

### Example 2-24 Creating an Incremental Backup for Refresh of a Standby Database

In this example, your goal is make an incremental backup of the primary database and use it to update an associated standby database. You start the RMAN client, **CONNECT** to the primary database as **TARGET**, and then connect to the recovery catalog. The **BACKUP** command creates an incremental backup of the primary database that can be applied at a standby database to update it with changes since the specified SCN.

```
RMAN> CONNECT TARGET /

connected to target database: PROD (DBID=39525561)

RMAN> CONNECT CATALOG rco@catdb

recovery catalog database Password: password
connected to recovery catalog database

RMAN> BACKUP DEVICE TYPE DISK
2> INCREMENTAL FROM SCN 404128 DATABASE
3> FORMAT '/disk1/incr_standby_%U';
```

### Example 2-25 Specifying Corruption Tolerance for Data File Backups

This example assumes a database that contains five data files. It uses the `SET MAXCORRUPT` command to indicate that only one corruption is tolerated in each data file. Because the `CHECK LOGICAL` option is specified on the `BACKUP` command, RMAN checks for both physical and logical corruption.

```
RUN
{
  SET MAXCORRUPT FOR DATAFILE 1,2,3,4,5 TO 1;
  BACKUP CHECK LOGICAL
    DATABASE;
}
```

### Example 2-26 Creating a Consistent Database Backup for Archival Purposes

This example uses a `keepOption` to create an archival backup set that cannot be considered obsolete for one year. The example backs up the database, archives the redo in the current online logs to ensure that this new backup is consistent, and backs up only those archived redo log files needed to restore the data file backup to a consistent state.

The `BACKUP` command also creates a restore point to match the SCN at which this backup is consistent. The `FORMAT` parameter must be capable of creating multiple backup pieces in multiple backup sets.

```
BACKUP DATABASE
  FORMAT '/disk1/archival_backups/db_%U.bck'
  TAG quarterly
  KEEP UNTIL TIME 'SYSDATE + 365'
  RESTORE POINT Q1FY06;
```

### Example 2-27 Exempting Copies from the Retention Policy

The following example copies two data files and exempts them from the retention policy forever. The control file and server parameter file are also backed up, even with autobackup off.

`KEEP FOREVER` requires a recovery catalog.

```
SHUTDOWN IMMEDIATE;
STARTUP MOUNT;
BACKUP
  KEEP FOREVER
  FORMAT '?/dbs/%U_longterm.cpy'
  TAG LONGTERM_BCK
  DATAFILE 1 DATAFILE 2;
ALTER DATABASE OPEN;
```

### Example 2-28 Backing Up Files That Need Backups

Assume that you back up the database and archived redo log files every night to tape by running the following command.

```
BACKUP
  MAXSETSIZE 500M
  DATABASE PLUS ARCHIVELOG;
```

The preceding command sets an upper limit to the size of each backup set so that RMAN produces multiple backup sets. Assume that the media management device fails halfway through the backup and is then restarted. The next day you discover that only half the backup sets completed. In this case, you can run the following command in the evening:

```
BACKUP
  NOT BACKED UP SINCE TIME 'SYSDATE-1'
```



```
MAXSETSIZE 500M
DATABASE PLUS ARCHIVELOG;
```

With the preceding command, RMAN backs up only files not backed up during in the previous 24 hours. When RMAN determines that a backup from the specified time window is available, it displays output like the following:

```
skipping datafile 1; already backed up on 18-JAN-13
skipping datafile 2; already backed up on 18-JAN-13
skipping datafile 3; already backed up on 18-JAN-13
```

If you place the `NOT BACKED UP SINCE` clause immediately after the `BACKUP` command, then it affects all objects to be backed up. You can also place it after individual `backupSpec` clauses to cause only backups for those objects described by the `backupSpec` to be subject to the limitation.

### Example 2-29 Using NODUPLICATES To Back Up Data File Copies

This example creates a data file copy of data file 2 named `/disk2/df2.cpy`. The example then backs up this data file copy to the `/disk1` and `/disk3` directories. The `NODUPLICATES` option on the final `BACKUP` command indicates that only one copy of data file 2 is backed up.

```
BACKUP AS COPY
  DATAFILE 2
  FORMAT '/disk2/df2.cpy' TAG my_tag;
BACKUP AS COPY
  DATAFILECOPY '/disk2/df2.cpy'
  FORMAT '/disk1/df2.cpy';
BACKUP AS COPY
  DATAFILECOPY '/disk1/df2.cpy'
  FORMAT '/disk3/df2.cpy';
BACKUP
  DEVICE TYPE sbt
  DATAFILECOPY ALL NODUPLICATES; # backs up only copy of data file 2
```

### Example 2-30 Copying Archived Log From Operating System File to ASM

```
BACKUP AS COPY REUSE
ARCHIVELOG LIKE "/ade/b/369893928/oracle/work/arc_dest/arcr_1_11_686060575.arc"
AUXILIARY FORMAT "+RCVAREA";
```

### Example 2-31 Multisection Backup of Data Files as Image Copies

This example creates a multisection backup of the data file `users_df.dbf`. The backup is created as image copies and each backup piece cannot exceed 150MB.

```
BACKUP AS COPY
SECTION SIZE 150M
DATAFILE '/oradata/dbs/users_df.dbf';
```

### Example 2-32 Multisection Incremental Backup of Database as Backup Sets

This example creates a multisection incremental backup of the database as backup sets. The incremental backup includes all data file blocks that changed at SCN greater than or equal to 8564. The `FORMAT` clause is mandatory when you use `INCREMENTAL FROM SCN` to create a multisection incremental backup.

```
BACKUP
FORMAT '/tmp/datafiles/db_incr_ms_%U'
INCREMENTAL FROM SCN 8564
SECTION SIZE 400M
DATABASE;
```

**Example 2-33 Multisection Incremental Backup of Tablespaces**

This example creates a multisection incremental backup of the tablespace `orders` as backup sets. Before creating the backup, three channels are explicitly allocated using the `ALLOCATE CHANNEL` command. Therefore, RMAN uses these channels to write, in parallel, to the backup pieces.

```
run {
  ALLOCATE CHANNEL MY_CH1 TYPE DISK;
  ALLOCATE CHANNEL MY_CH2 TYPE DISK;
  ALLOCATE CHANNEL MY_CH3 TYPE DISK;
  BACKUP
    INCREMENTAL LEVEL 1
    AS COMPRESSED BACKUPSET
    SECTION SIZE 100M
    TABLESPACE sales;
};
```

**Example 2-34 Cross-Platform Backup of the Entire Database**

This example creates a cross-platform backup of the entire database for transport to the Linux x86 64-bit platform. The source platform is Microsoft Windows IA (32-bit) and the backup is stored in a backup set named `full_db.bck`. The database must be placed in read-only mode before the backup is created.

```
BACKUP
  TO PLATFORM='Linux x86 64-bit'
  FORMAT '/tmp/xplat_backups/full_db.bck'
  DATABASE;
```

**Example 2-35 Cross-Platform Backup of a Consistent Tablespace**

This example backs up the tablespace `example` for cross-platform transport. The tablespace must be placed in read-only mode before the backup is performed. The backup set containing the tablespace data is called `example_readonly.bck`. The metadata required to plug this tablespace into the target database is stored in the backup set `example_dmp.bck`.

```
BACKUP
  FOR TRANSPORT
  FORMAT '/tmp/xplat_backups/example_readonly.bck'
  TABLESPACE example
  DATAPUMP FORMAT '/tmp/xplat_backups/example_dmp.bck';
```

**Example 2-36 Cross-Platform Backup of a Tablespace Using Multiple Backup Sets**

This example creates a cross-platform backup of the tablespace `example` using multiple backup sets. Ensure that the tablespace is read-only before you create the backup. Because `FILESERSET` is set to 1, each backup set contains only one input file. The backup sets use unique names that begin with `db_multiple_`.

```
BACKUP
  FOR TRANSPORT
  FILESERSET 1
  FORMAT '/tmp/xplat_backups/db_multiple_%U'
  TABLESPACE example
  DATAPUMP FORMAT '/tmp/xplat_backups/db_multiple.dmp';
```

**Example 2-37 Cross-Platform Backup of a Tablespace Using Multiple Backup Pieces**

This example creates a cross-platform backup of the tablespace `example`. The backup uses multiple backup pieces because `MAXPIECESIZE` is set in the `ALLOCATE CHANNEL` command. Ensure that the tablespace is in read-only mode before the backup is created.

```
RUN
{
  ALLOCATE CHANNEL c1 DEVICE TYPE disk MAXPIECESIZE 301464;
  BACKUP
    FOR TRANSPORT
    FORMAT '/tmp/xplat_backups/example_multi-piece.bck'
    TABLESPACE example
    DATAPUMP FORMAT '/tmp/xplat_backups/example_multi-piece_dmp.bck';}
```

**Example 2-38 Cross-Platform Inconsistent Backup of a Tablespace**

This example creates a cross-platform level 0 incremental backup of the tablespace `example`. The tablespace is in read-write mode at the time of creating the backup and, therefore, you use `ALLOW INCONSISTENT` to create an inconsistent backup.

Note that inconsistent backups of tablespaces cannot be used to directly plug the tablespace into the destination database. You must use an incremental backup of the tablespace that is created when the tablespace is read-only to make the tablespace consistent. [Example 2-39](#) describes how to create a cross-platform incremental backup.

```
BACKUP
  FOR TRANSPORT
  ALLOW INCONSISTENT
  INCREMENTAL LEVEL 0
  FORMAT '/tmp/xplat_backups/example_inconsist.bck'
  TABLESPACE example;
```

**Example 2-39 Cross-Platform Incremental Backup of a Tablespace**

This example creates a cross-platform level 1 incremental backup of the tablespace `example`. The tablespace is placed in read-only mode before this backup is created. This backup contains changes made to the tablespace after the most recent incremental backup was created. The backup is stored in a backup set called `example_inconsist_incr.bck`. The metadata required to plug the tablespace into the destination database is stored in the backup set `example_incr_dmp.bck`.

You can use this level 1 incremental backup, along with the level 0 incremental backup created in [Example 2-38](#), to transport the tablespace `example` to a different platform. On the destination database, you first restore the level 0 incremental backup created in [Example 2-38](#) to create a set of foreign data files. These foreign data files are inconsistent because the tablespace was in read/write mode when the level 0 incremental backup was created. You then apply a level 1 incremental backup to the foreign data files. Next, you plug the tablespace in to the destination database by restoring the backup set specified in the `DATAPUMP` clause. See *Oracle Database Backup and Recovery User's Guide* for a complete example of performing cross-platform inconsistent tablespace transport using backup sets.

In most scenarios, after creating the level 0 incremental backup, you create multiple level 1 incremental backups with the tablespace is placed in read/write mode. The final incremental level 1 backup is created with the tablespace placed in read-only mode.

These incremental backups that are created and applied over time help minimize the data divergence between the source and destination database.

```
BACKUP
  FOR TRANSPORT
  INCREMENTAL LEVEL 1
  TABLESPACE example
  FORMAT '/tmp/xplat_backups/example_inconsist_incr.bck'
  DATAPUMP FORMAT '/tmp/xplat_backups/example_incr_dmp.bck';
```

## 2.7 CATALOG

### Purpose

Use the `CATALOG` command to do the following:

- Add backup pieces and image copies on disk to the RMAN repository
- Record a data file copy as a level 0 incremental backup in the RMAN repository, which enables you to use it as part of an incremental backup strategy



### See Also:

*Oracle Database Backup and Recovery User's Guide* to learn how to manage target database records stored in the catalog

### Prerequisites

You must be connected to the target database, which must be mounted or open. If RMAN is connected to a recovery catalog, then the catalog database must be open.

The file that you are cataloging must meet the following conditions:

- It must not exist on an SBT device.
- If it is a user-managed copy, then it must be a data file copy, control file copy, archived redo log, or backup piece.

### Usage Notes

RMAN considers all user-managed backups as image copies. While cataloging, RMAN does not check whether the file was correctly copied by the operating system utility: it just checks the header.

A recovery catalog is required when using RMAN in a Data Guard environment. The recovery catalog supports a unified file namespace for all primary and standby databases with the same DBID but different `DB_UNIQUE_NAME` values. Thus, the recovery catalog keeps track of database file names for all primary and standby databases, and also where online redo logs, standby redo logs, temp files, archived redo log files, backup sets, and image copies were created.

"[RMAN Backups in a Data Guard Environment](#)" explains how RMAN handles backups made on a different primary and standby databases. In general, tape backups made on one database are accessible to any database in the environment, whereas disk backups are accessible only to the database that created them.

If backups are accessible to the connected target database, RMAN commands such as [RESTORE](#) and [RECOVER](#) behave transparently across different databases. You can manually transfer a disk backup from one host in the environment to another host and then catalog the backup. If a backup is on shared disk, then you can use [CHANGE RESET DB\\_UNIQUE\\_NAME](#) to associate the backup with a new database.

## Syntax

**catalog::=**

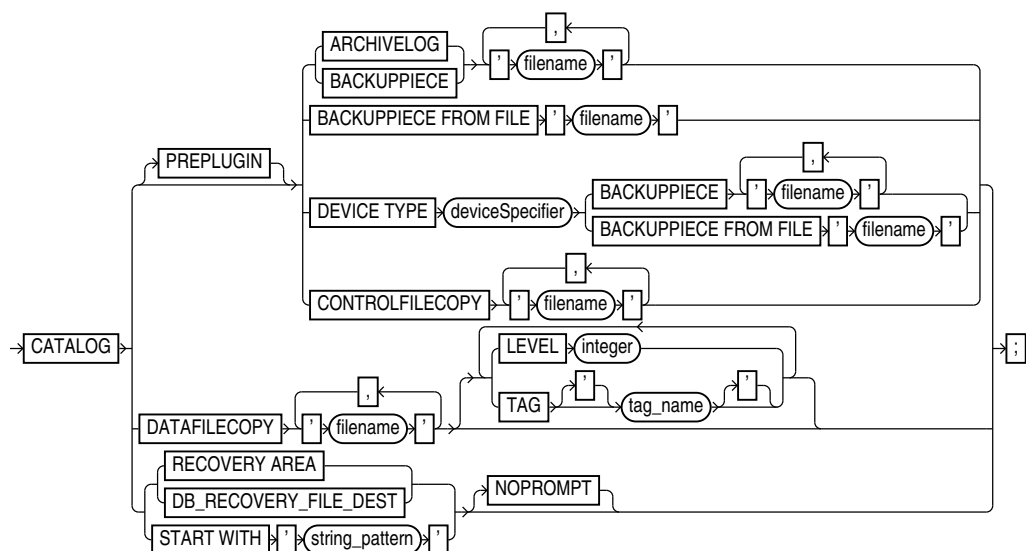

## Semantics

Syntax Element	Description
PREPLUGIN ARCHIVELOG	Specifies the names of preplugin archived redo logs that must be added to the RMAN repository. Use a comma-separated list to specify multiple names. This command is used to catalog preplugin backups that were created on a source database and subsequently moved to a different backup location. The CDB must be open in read-write mode and you must be connected to the root as a common user with the SYSDBA or SYSBACKUP privilege. <b>Note:</b> You cannot catalog preplugin backups created on standby databases. To restore standby data files, you must copy the data files from the primary using RESTORE...FROM SERVICE command.
PREPLUGIN BACKUPPIECE	This clause is not supported in the current release.
PREPLUGIN CONTROLFILECOPY	This clause is not supported in the current release.
ARCHIVELOG 'filename'	Specifies the file name of an archived redo log to be added to the RMAN repository. <b>Note:</b> This command does not catalog foreign archived redo log files, which are redo logs received by a logical standby database for a LogMiner session. Unlike normal archived redo log files, foreign archived redo log files have a different DBID.

Syntax Element	Description
BACKUPPIECE ' <i>filename</i> '	<p>Specifies the name of a backup piece to be added to the RMAN repository (see <a href="#">Example 2-40</a>).</p> <p>The backup piece must be on disk. RMAN verifies the backup piece header before cataloging it. RMAN can catalog a backup piece from a previous database incarnation.</p> <p>You may choose to catalog backup pieces in the following situations:</p> <ul style="list-style-type: none"> <li>You copy or move a backup piece with an operating system utility and want it to be usable by RMAN.</li> <li>The RMAN metadata for the backup piece was removed, but the backup piece still exists. This situation can occur if you ran the <code>DELETE</code> command on a backup piece that was only temporarily unavailable.</li> <li>You make a <code>NOCATALOG</code> backup on one database host in a Data Guard environment and move the backup piece to the same location on a different database host. In this case, the recovery catalog has no record of the original backup piece.</li> <li>You do not use a recovery catalog and must re-create the control file, thereby losing all RMAN repository data. Cataloging your backups makes them available again.</li> <li>When control file autobackup is disabled, you back up the control file and then back up the archived redo log files. You can restore and mount the control file, but must catalog the backup pieces containing the archived redo log files backed up after the control file.</li> </ul> <p>If you specify a list of backup pieces, then RMAN attempts to catalog all pieces in the given list even if some of them fail. Cataloging a backup piece creates a new row in <code>V\$BACKUP_PIECE</code>. A backup set is only usable when <i>all</i> backup pieces are cataloged because otherwise it is only in a partially available state.</p> <p><b>Note:</b> If RMAN creates a server parameter file backup when the <code>COMPATIBLE</code> parameter of the database is set to 11.0.0 or higher, then the backup is associated with this database. In this case, even if you connect RMAN to a different database and explicitly catalog the backup piece, the <code>DB_UNIQUE_NAME</code> associated with this backup does not change. For example, if RMAN backs up the server parameter file of the database with <code>DB_UNIQUE_NAME 'NEWYORK'</code> when <code>COMPATIBLE</code> is 11.0.0, then RMAN cannot use the server parameter file backup created at database <code>NEWYORK</code> to restore the server parameter file on database <code>BOSTON</code>.</p>
BACKUPPIECE FROM FILE ' <i>filename</i> '	<p>Specifies the name of the XML file that contains the list of backup piece names to be added to the RMAN repository.</p> <p>If the backup piece names are stored in an XML file, then use the <code>BACKUPPIECE FROM FILE</code> clause to specify the location of the XML file using <i>filename</i>.</p> <p>For example: <code>CATALOG BACKUPPIECE FROM FILE 'home/oracle/OPC/metadata.xml'</code></p> <p>See <a href="#">Extracting Backup Metadata from a Storage Bucket or a Container in <i>Using Oracle Database Backup Cloud Service</i></a> to learn how to construct an XML file for backups stored in Oracle Cloud.</p> <p><a href="#">Example 2-44</a> includes the sample contents of an XML file that contains the backup piece names.</p>

Syntax Element	Description
CONTROLFILECOPY ' <i>filename</i> '	<p>Specifies the file name of a control file copy to be added to the RMAN repository. The control file copy can be a normal or standby control file copy created by one of the following commands:</p> <ul style="list-style-type: none"> <li>• RMAN: <b>BACKUP</b> AS COPY CURRENT CONTROLFILE</li> <li>• SQL: ALTER DATABASE BACKUP CONTROLFILE</li> <li>• SQL: ALTER DATABASE CREATE STANDBY CONTROLFILE</li> </ul> <p><b>Note:</b> RMAN can automatically convert a primary database control file backup to a standby control file during a restore operation.</p>
DATAFILECOPY ' <i>filename</i> '	<p>Specifies the file name of a data file copy to be added to the RMAN repository (see <a href="#">Example 2-40</a>). You can create data file copies with the RMAN <b>BACKUP</b> AS COPY command or with operating system utilities used with ALTER TABLESPACE BEGIN/END BACKUP.</p>
LEVEL <i>integer</i>	<p>Records the data file copy as a level 0 incremental backup (0 is the only valid value of LEVEL).</p> <p>You can perform incremental backups by using this data file copy as the base level 0 backup.</p>
TAG <i>tagname</i>	<p>Specifies a tag for the data file copy.</p>
RECOVERY AREA	<p>Catalogs all valid backup sets, data file copies, and archived redo log files in the fast recovery area (see <a href="#">Example 2-42</a>).</p> <p>RMAN must be connected to a database as TARGET. The target database must be mounted or open. The keywords RECOVERY AREA and DB_RECOVERY_FILE_DEST are exact synonyms.</p> <p><b>Note:</b> This command also catalogs foreign archived redo log files, which are archived redo log files received by logical standby for a LogMiner session, if they exist in the fast recovery area.</p>
DB_RECOVERY_FILE_DEST	<p>The keywords RECOVERY AREA and DB_RECOVERY_FILE_DEST are exact synonyms.</p>
START WITH ' <i>string_pattern</i> '	<p>Catalogs all valid backup sets, data file and control file copies, and archived redo log files whose name start with <i>string_pattern</i>. The string pattern can be an ASM disk group, Oracle-managed files directory, or part of a file name (see <a href="#">Example 2-41</a>).</p> <p>RMAN reports any files in the disk location that it cannot catalog. RMAN must be connected to a mounted target database.</p> <p>If the string pattern specifies a file name, then it matches the left part of the file name pattern. For example, /tmp/arc matches everything in directories /tmp/arc_dest and /tmp/archive/january, and file /tmp/arc.cpy.</p> <p><b>Note:</b> You cannot use wildcard characters in the string pattern, only a strict prefix.</p>
NOPROMPT	<p>Suppresses the confirmation prompt. By default, RMAN prompts after every match.</p>

## Examples

### Example 2-40 Cataloging a Data File Copy as an Incremental Backup

Assume that you used a Linux utility to back up the users01.dbf data file to /disk2/backup/users01.bak. This example catalogs the data file copy as an incremental level 0 backup and then lists all copies.

```
CATALOG DATAFILECOPY '/disk2/backup/users01.bak' LEVEL 0;
LIST COPY;
```

**Example 2-41 Cataloging Multiple Copies in a Directory**

This example catalogs a directory full of archived redo log files that were copied into the /disk2/archlog directory with an operating system utility. The example includes sample output.

```
CATALOG START WITH '/disk2/archlog' NOPROMPT;

searching for all files that match the pattern /disk2/archlog

List of Files Unknown to the Database
=====
File Name: /disk2/archlog/o1_mf_1_10_24trtc7s_.arc
File Name: /disk2/archlog/o1_mf_1_11_24trtg7s_.arc
File Name: /disk2/archlog/o1_mf_1_12_24trtk84_.arc
File Name: /disk2/archlog/o1_mf_1_13_24trtn85_.arc
File Name: /disk2/archlog/o1_mf_1_14_24trtq84_.arc
File Name: /disk2/archlog/o1_mf_1_15_24trtt84_.arc
File Name: /disk2/archlog/o1_mf_1_16_24trtx84_.arc
File Name: /disk2/archlog/o1_mf_1_17_24trv085_.arc
File Name: /disk2/archlog/o1_mf_1_18_24trv385_.arc
File Name: /disk2/archlog/o1_mf_1_19_24trv685_.arc
cataloging files...
cataloging done

List of Cataloged Files
=====
File Name: /disk2/archlog/o1_mf_1_10_24trtc7s_.arc
File Name: /disk2/archlog/o1_mf_1_11_24trtg7s_.arc
File Name: /disk2/archlog/o1_mf_1_12_24trtk84_.arc
File Name: /disk2/archlog/o1_mf_1_13_24trtn85_.arc
File Name: /disk2/archlog/o1_mf_1_14_24trtq84_.arc
File Name: /disk2/archlog/o1_mf_1_15_24trtt84_.arc
File Name: /disk2/archlog/o1_mf_1_16_24trtx84_.arc
File Name: /disk2/archlog/o1_mf_1_17_24trv085_.arc
File Name: /disk2/archlog/o1_mf_1_18_24trv385_.arc
File Name: /disk2/archlog/o1_mf_1_19_24trv685_.arc
```

**Example 2-42 Cataloging Files in the Fast Recovery Area**

This example catalogs all files in the currently enabled fast recovery area without prompting the user for each one. As shown in the sample output, RMAN displays a message if it finds no files to catalog.

```
CATALOG RECOVERY AREA;

searching for all files in the recovery area
no files found to be unknown to the database
```

**Example 2-43 Cataloging a Backup Piece**

Assume that you use an operating system utility to copy a backup piece from one location to another. This example catalogs the backup piece in the new location (sample output included):

```
CATALOG BACKUPPIECE '/disk1/c-874220581-20131128-01';

using target database control file instead of recovery catalog
cataloged backup piece
backup piece handle=/disk1/c-874220581-20131128-01 RECID=12 STAMP=607695990
```



### Example 2-44 Sample of a Backup Metadata XML File

The `metadata.xml` file stores the metadata of a backup piece.

```
<MetaData>
  <File>
    <Filename>6GJ28IEKFL_07CEC18D372F4D29E06379624664E053</Filename>
    <SetStamp>1150345378</SetStamp>
    <IsSpfile>NO</IsSpfile>
    <IsControlFile>NO</IsControlFile>
    <PieceNo>1</PieceNo>
    <Dbname>SALESDB</Dbname>
    <Dbid>3483424530</Dbid>
  </File>
  <File>
    <Filename>6GJ28IEKFL_07CEC1A6254D4D36E0637962466444CD</Filename>
    <SetStamp>1150345451</SetStamp>
    <IsSpfile>NO</IsSpfile>
    <IsControlFile>NO</IsControlFile>
    <PieceNo>1</PieceNo>
    <Dbname>SALESDB</Dbname>
    <Dbid>3483424530</Dbid>
  </File>
</MetaData>
```

## 2.8 CHANGE

### Purpose

Use the `CHANGE` command to perform the following tasks:

- Update the availability status of backups and copies recorded in the RMAN repository
- Change the priority of or close failures recorded in the automatic diagnostic repository
- Update the `DB_UNIQUE_NAME` recorded in the recovery catalog for the target database
- Associate the backup of a database in a Data Guard environment with a different database in the environment

#### See Also:

*Oracle Database Backup and Recovery User's Guide* to change the availability status of a backup or copy

### Prerequisites

RMAN must be connected as `TARGET` to a database instance, which must be started.

### Usage Notes

"[RMAN Backups in a Data Guard Environment](#)" explains the difference between the association and accessibility of a backup. In a Data Guard environment, the database that creates a backup or copy is associated with the file. You can use maintenance commands such as `CHANGE`, `DELETE`, and `CROSSCHECK` for backups when connected to any database in the Data Guard environment if the backups are accessible. In general, RMAN considers tape backups created on any database as accessible to all databases in the environment, whereas disk backups are accessible only to the database that created them.

For example, suppose that you connect RMAN as `TARGET` to standby database `standby1` and back it up to tape and disk. If the tape drive becomes unavailable, then you can connect RMAN as `TARGET` to any primary or standby database in the Data Guard environment to change the status of the tape backup to `UNAVAILABLE`. After the tape drive is repaired, you can connect RMAN as `TARGET` to any database to change the status of the tape backup back to `AVAILABLE`. However, if the disk backup is accidentally removed by an operating system utility, then RMAN can only change the status of the disk backup when connected as `TARGET` to `standby1`.

### Syntax

**change::=**

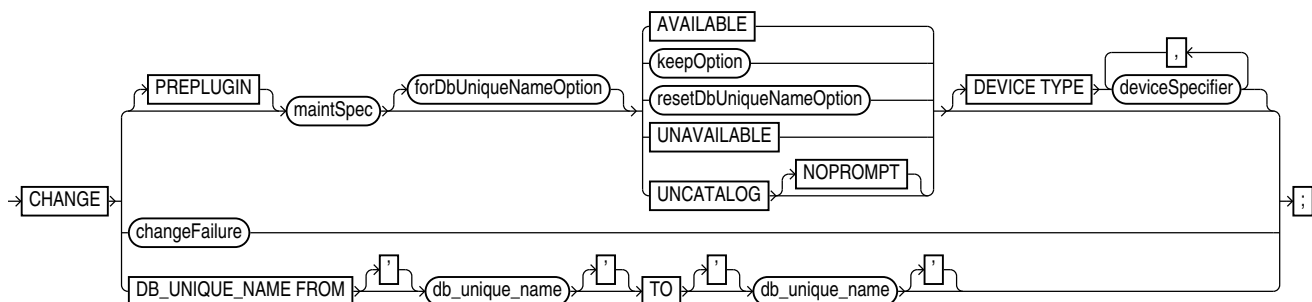

([maintSpec::=](#), [forDbUniqueNameOption::=](#), [keepOption::=](#), [deviceSpecifier::=](#))

**maintSpec::=**

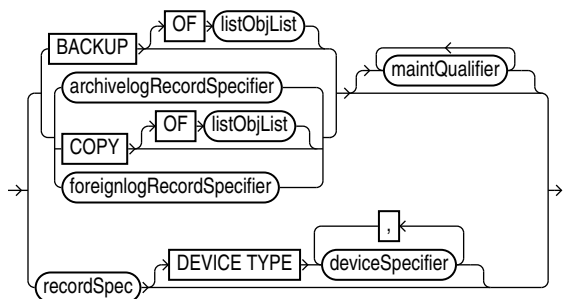

([listObjList::=](#), [archivelogRecordSpecifier::=](#), [maintQualifier::=](#), [recordSpec::=](#), [deviceSpecifier::=](#))

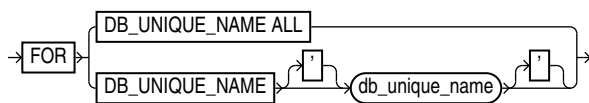
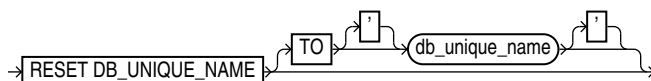
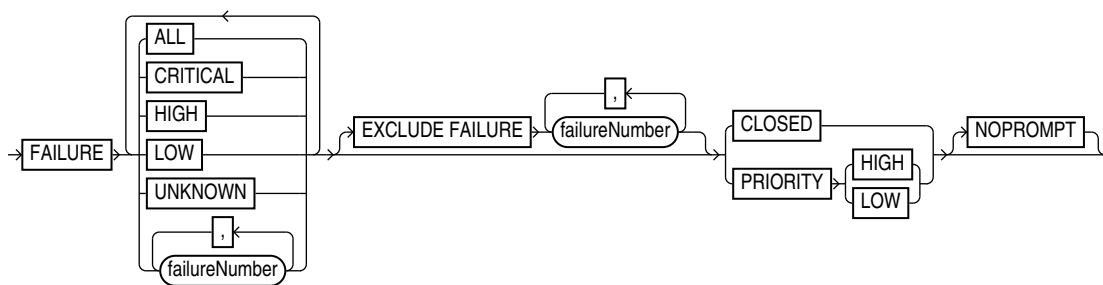
**forDbUniqueNameOption::=****resetDbUniqueNameOption::=****changeFailure::=****Semantics****change**

This clause enables you to change the status of RMAN repository records. To obtain the primary keys of RMAN repository records whose status you want to change, run a [LIST](#) command or query the recovery catalog views.

Syntax Element	Description
PREPLUGIN	Specifies the preplugin files that you want to <b>CHANGE</b> .
<a href="#">maintSpec</a>	Specifies which files you want to <b>CHANGE</b> .  The <a href="#">maintQualifier</a> clause sets rules for the repository records that must be changed. To change the status of repository records associated with PDBs that were dropped, use the <a href="#">GUID</a> clause to specify the GUID of the dropped PDB. The <a href="#">dba_pdb_history</a> view contains the GUID of dropped PDBs. <b>See Also:</b> <a href="#">maintSpec</a> for descriptions of the options in this clause.
<a href="#">forDbUniqueNameOption</a>	Changes the metadata for objects that are exclusively associated with the specified <code>DB_UNIQUE_NAME</code> in a Data Guard environment. <b>See Also:</b> <a href="#">forDbUniqueNameOption</a> for descriptions of the options in this clause.

Syntax Element	Description
AVAILABLE	<p>Changes the status of a backup or copy to <code>AVAILABLE</code> in the repository. RMAN searches for the file and verifies that it exists.</p> <p>This feature is useful when a previously unavailable file is made available again. You can also use this option to alter the repository status of backups and copies from prior incarnations.</p> <p>This is the only <code>CHANGE</code> option that requires either a manual or automatic maintenance channel. A maintenance channel is not required, however, when <code>CHANGE . . . AVAILABLE</code> is used with a file that is disk only (that is, an <code>ARCHIVELOG</code>, <code>DATAFILECOPY</code>, or <code>CONTROLFILECOPY</code>). If you use <code>CHANGE . . . AVAILABLE</code> on files that are not disk-only, and have objects created on device types that are not configured for automatic channels, then issue manual maintenance commands on these channels. For example, if you created a backup on an <code>sbt</code> channel, but have only a <code>DISK</code> channel automatically configured, then you must manually allocate an <code>sbt</code> channel before <code>CHANGE . . . AVAILABLE</code> can operate on the backup.</p> <p>If you execute <code>CHANGE . . . AVAILABLE</code> for a file in a Data Guard environment, then RMAN attempts to cross-check the file before updating its status to <code>AVAILABLE</code>. If the file is inaccessible, then RMAN prompts you to perform the same operation when connected as <code>TARGET</code> to the database associated with the file. If the file is accessible, then RMAN updates the status as requested.</p> <p><b>Note:</b> You can view the status of backups in the <a href="#">LIST</a> output or recovery catalog views.</p> <p><b>Note:</b> <code>CHANGE . . . AVAILABLE</code> is not valid for foreign archived redo log files, which are received by a logical standby database for a LogMiner session. Unlike normal archived redo log files, foreign archived redo log files have a different DBID.</p>
<a href="#">keepOption</a>	<p>Changes the exemption status of a backup or copy in relation to the configured retention policy. For example, specify <code>CHANGE . . . NOKEEP</code> to remove the <code>KEEP</code> attributes for a backup, making it subject to the backup retention policy.</p> <p>The <code>KEEP FOREVER</code> clause requires use of a recovery catalog (see <a href="#">Example 2-47</a>). The <code>RESTORE POINT</code> option is not valid with <code>CHANGE</code>. You cannot use <code>CHANGE . . . UNAVAILABLE</code> or <code>KEEP</code> attributes for files stored in the fast recovery area.</p> <p><b>See Also:</b> <a href="#">keepOption</a></p>
<a href="#">resetDbUniqueNameOption</a>	<p>Associates the files in <a href="#">maintSpec</a> with a different database in a Data Guard environment.</p> <p><b>See Also:</b> <a href="#">resetDbUniqueNameOption</a></p>

Syntax Element	Description
UNAVAILABLE	<p>Changes the status of a backup or copy to <code>UNAVAILABLE</code> in the repository (see <a href="#">Example 2-45</a>). View the status in the <code>LIST</code> output or recovery catalog views.</p> <p>This option is useful when a file cannot be found or has migrated offsite. RMAN does not use a file that is marked <code>UNAVAILABLE</code> in a <code>RESTORE</code> or <code>RECOVER</code> command. If the file is later found or returns to the main site, then use the <code>AVAILABLE</code> option to update its status. The <code>UNAVAILABLE</code> option is also useful when you do not want a specific backup or copy to be eligible to be restored but also do not want to delete it, or when you want to alter the repository status of backups and copies from prior incarnations.</p> <p><code>CHANGE . . . UNAVAILABLE</code> is not valid for files in the fast recovery area. This command is also not valid for foreign archived redo log files, which are received by a logical standby database for a LogMiner session. Unlike normal archived redo log files, foreign archived redo log files have a different DBID.</p> <p><b>Note:</b> If you execute <code>CHANGE . . . UNAVAILABLE</code> for a file in a Data Guard environment, then RMAN does not attempt to cross-check the file before updating its status to <code>UNAVAILABLE</code>. RMAN updates the status as requested regardless of whether the file physically exists.</p> <p><b>Note:</b> The <code>CHANGE . . . UNAVAILABLE</code> command cannot be used when you back up target databases to Zero Data Loss Recovery Appliance, commonly known as Recovery Appliance.</p>
UNCATALOG	<p>Removes references to a data file copy, backup piece, backup set, or archived redo log from the recovery catalog, and updates records in the target control file to status <code>DELETED</code> (see <a href="#">Example 2-46</a>). Use <code>CHANGE BACKUPSET ... UNCATALOG</code> to uncatalog all the backup pieces in a backupset.</p> <p>The <code>CHANGE . . . UNCATALOG</code> command does not touch physical backups and copies. Use this command to notify RMAN when a file is deleted by some means other than a <code>DELETE</code> command.</p> <p>If you execute <code>CHANGE . . . UNCATALOG</code> for a file in a Data Guard environment, then RMAN does not attempt to cross-check the file before removing its metadata from the recovery catalog. RMAN removes the metadata as requested regardless of whether the file physically exists.</p> <p><b>Caution:</b> If you resynchronize from a backup control file, or upgrade the recovery catalog, then records previously removed from the RMAN repository with <code>CHANGE . . . UNCATALOG</code> may reappear in the recovery catalog.</p> <p><b>Note:</b> The <code>CHANGE . . . UNCATALOG</code> command cannot be used when you back up target databases to Zero Data Loss Recovery Appliance, commonly known as Recovery Appliance.</p>
NOPROMPT	<p>Does not display a prompt when performing an uncatalog operation with the recovery catalog.</p>
<a href="#">DEVICE TYPE deviceSpecifier</a>  <a href="#">changeFailure</a>	<p>Executes the <code>CHANGE</code> for the specified device type only (see <a href="#">deviceSpecifier</a>). This option is valid only if you have configured automatic channels and have not manually allocated channels. For example, if you run <code>CHANGE UNCATALOG . . . DEVICE TYPE DISK</code>, then RMAN only uncatalogs files on disk.</p> <p>Specifies changes for failures recorded by the Data Recovery Advisor. Starting in Oracle Database 19c, the Data Recovery Advisor (DRA) feature is deprecated.</p> <p>The deprecation of DRA includes deprecation of the following Oracle Recovery Manager (RMAN) commands: <code>LIST FAILURE</code>, <code>ADVISE FAILURE</code>, <code>REPAIR FAILURE</code>, and <code>CHANGE FAILURE</code>. Database administrators will no longer have access to these commands. There is no replacement feature for DRA.</p>

Syntax Element	Description
<pre>DB_UNIQUE_NAME FROM db_unique_name TO db_unique_name</pre>	<p>Updates the metadata in the recovery catalog to reflect a new <code>DB_UNIQUE_NAME</code> for a database in a Data Guard environment. The first value specifies the old <code>DB_UNIQUE_NAME</code> for the database currently recorded in the recovery catalog, whereas the second specifies the new <code>DB_UNIQUE_NAME</code>.</p> <p>RMAN must be connected to a recovery catalog and a mounted target database. The target database must not have the <code>DB_UNIQUE_NAME</code> specified in the <code>FROM db_unique_name</code> parameter; otherwise, RMAN signals an error.</p> <p>Typically, you use this command after you have changed the <code>DB_UNIQUE_NAME</code> initialization parameter of a database and must update its metadata in the recovery catalog. In general, do not run this command before performing any other RMAN operations on a renamed database. The recommended practice is to execute <code>LIST DB_UNIQUE_NAME</code> before <code>CHANGE DB_UNIQUE_NAME</code>.</p> <p>Assume that you changed the <code>DB_UNIQUE_NAME</code> initialization parameter for a standby database from <code>standby_old</code> to <code>standby_new</code>. Typically, you execute <code>CHANGE DB_UNIQUE_NAME</code> in the following scenarios:</p> <ul style="list-style-type: none"> <li>• A <code>LIST DB_UNIQUE_NAME</code> command shows the old <code>DB_UNIQUE_NAME</code> value but does <i>not</i> show the new one (see <a href="#">Example 2-50</a>).</li> <li>• A <code>LIST DB_UNIQUE_NAME</code> command shows both the old <i>and</i> new <code>DB_UNIQUE_NAME</code> values. When RMAN connects as <code>TARGET</code> to a database with an unrecognized <code>DB_UNIQUE_NAME</code>, RMAN implicitly registers the instance as a new database. For this reason, <code>LIST DB_UNIQUE_NAME</code> command can show both the old and new names (in this example, <code>standby_old</code> and <code>standby_new</code>) for a database whose <code>DB_UNIQUE_NAME</code> initialization parameter has been changed.</li> </ul> <p>In the scenario in which only the old name is listed, execute <code>CHANGE DB_UNIQUE_NAME FROM standby_old TO standby_new</code> so that RMAN changes the <code>DB_UNIQUE_NAME</code> for <code>standby_old</code> to <code>standby_new</code> in the recovery catalog.</p> <p>In the scenario in which both the old and new names are listed, RMAN automatically executes the following commands when you run <code>CHANGE DB_UNIQUE_NAME FROM standby_old TO standby_new</code>:</p> <ol style="list-style-type: none"> <li>1. <code>CHANGE ARCHIVELOG ALL FOR DB_UNIQUE_NAME standby_old RESET DB_UNIQUE_NAME</code></li> <li>2. <code>CHANGE BACKUP FOR DB_UNIQUE_NAME standby_old RESET DB_UNIQUE_NAME</code></li> <li>3. <code>UNREGISTER DB_UNIQUE_NAME standby_old</code></li> </ol> <p>Thus, RMAN changes the association of all backups for the <code>DB_UNIQUE_NAME</code> specified in the <code>FROM</code> clause to the <code>DB_UNIQUE_NAME</code> specified in the <code>TO</code> clause.</p>

### ***resetDbUniqueNameOption***

This clause enables you to associate backups made on one database in a Data Guard environment with a different database in the environment. The following table explains the RMAN behavior when different options are specified with `RESET DB_UNIQUE_NAME`.

Table 2-2 RESET DB\_UNIQUE\_NAME Options

TO <i>db_unique_name</i>	FOR DB_UNIQUE_NAME	RMAN Behavior
No	No	RMAN associates the <a href="#">maintSpec</a> files with the target database. RMAN also changes the association of all backups that are not associated with any database.  Typically, you would execute <code>CHANGE</code> with these options after upgrading to an Oracle Database 11g or later recovery catalog schema, so that you can associate the backups with the target database.
Yes	No	RMAN associates the <a href="#">maintSpec</a> files with the database indicated by the TO <i>db_unique_name</i> . RMAN also changes the association of all backups that are not associated with any database.
No	Yes	RMAN restricts its operations to <a href="#">maintSpec</a> files that are associated with the database in the FOR DB_UNIQUE_NAME clause, and then associates these files with the target database.
Yes	Yes	RMAN restricts its operations to <a href="#">maintSpec</a> files that are associated with the database in the FOR DB_UNIQUE_NAME clause, and then associates these files with the database specified by TO <i>db_unique_name</i> .

Syntax Element	Description
<code>RESET DB_UNIQUE_NAME</code>	<p>Associates the files in <a href="#">maintSpec</a> with the target database (see <a href="#">Example 2-49</a>). <a href="#">Table 2-2</a> explains the RMAN behavior when different options are specified.</p> <p>When changing the association of the files from one database to another database, RMAN deletes the duplicate names from the recovery catalog. For example, if you change the association of data file copy <code>/d1/df1.bak</code> from database <code>standby1</code> to database <code>prod</code>, then the recovery catalog has only one record for this file rather than two.</p> <p>Use caution when specifying the <code>RESET DB_UNIQUE_NAME</code> option because you cannot undo the effect of this command. For example, after you have changed the association of the files associated with database <code>standby1</code> to database <code>prod</code>, the recovery catalog does not retain historical metadata about the database with which these files were previously associated. However, you can unregister database <code>standby1</code> and connect RMAN again to <code>standby1</code>, but the recovery catalog is updated with all metadata from the <code>standby1</code> control file.</p>
<code>TO <i>db_unique_name</i></code>	Associates the files in <a href="#">maintSpec</a> with the specified database in a Data Guard environment.

**changeFailure**

This clause enables you to change the status of failures. Use the `LIST FAILURE` command to show the list of failures.

 **Note:**

Starting in Oracle Database 19c, the Data Recovery Advisor (DRA) feature is deprecated.

The deprecation of DRA includes deprecation of the following Oracle Recovery Manager (RMAN) commands: `LIST FAILURE`, `ADVISE FAILURE`, `REPAIR FAILURE`, and `CHANGE FAILURE`. Database administrators will no longer have access to these commands. There is no replacement feature for DRA.

Syntax Element	Description
FAILURE	Enables you to change priority or close failures recorded in the Automatic Diagnostic Repository. By default RMAN prompts for confirmation before performing the requested change. The target database to which RMAN is connected must be a single-instance database and must not be a physical standby database.
ALL	Changes only open failures.
CRITICAL	Changes only critical failures.
HIGH	Changes only failures with HIGH priority.
LOW	Changes only failures with LOW priority.
UNKNOWN	Changes only failures whose priority cannot be determined until the database is mounted.
<i>failnum</i>	Changes only the specified failure.
EXCLUDE FAILURE <i>failnum</i>	Excludes the specified failures from the change. Use a comma-delimited list to specify multiple failures
CLOSED	Closes the specified failures by setting their status to CLOSED.
PRIORITY	Changes the priority of the specified failures to LOW or HIGH.
NOPROMPT	Does not prompt for confirmation before modifying the specified failures.

## Examples

### Example 2-45 Updating Backups to Status UNAVAILABLE

Assume that you have temporarily moved backup set 4 to a different location because of a space issue on disk. The backup, which has the key 4, is still listed as available:

```
RMAN> LIST BACKUP SUMMARY;
```

```
List of Backups
```

```
=====
```

Key	TY	LV	S	Device	Type	Completion Time	#Pieces	#Copies	Compressed	Tag
1	B	A	A	DISK		24-FEB-13	1	1	NO	TAG20130427T115348
3	B	A	A	DISK		24-MAR-13	1	1	NO	TAG20130427T115452
4	B	F	A	DISK		24-APR-13	1	1	NO	TAG20130427T115456

You do not want to uncatalog the backup because you plan to move it back to its original location when more disk space is available. Thus, you make the backup unavailable as follows (sample output included):

```
RMAN> CHANGE BACKUPSET 4 UNAVAILABLE;
```



```

changed backup piece unavailable
backup piece handle=/disk2/backup/c-3257893776-20130424-00 RECID=4 STAMP=588858897
Changed 1 objects to UNAVAILABLE status

```

### Example 2-46 Uncataloging and Recataloging Archived Redo Log Files

In this example, you move all archived redo log files to a new directory, uncatalog them, and then recatalog them in the new location:

```

RMAN> HOST '/bin/mv $ORACLE_HOME/dbs/*.arc /disk2/archlog/';
RMAN> CHANGE ARCHIVELOG ALL UNCATALOG;
RMAN> CATALOG START WITH '/disk2/archlog' NOPROMPT;

```

### Example 2-47 Changing a Database Backup into an Archival Backup

Assume your goal is to change a database backup into an archival backup, which you plan to store offsite. Because the backup is consistent and requires no recovery, you do not need to store archived redo log files with the backup. The example uses the `CHANGE ... KEEP FOREVER` command to specify that the backup is never obsolete.

```

RMAN> CONNECT TARGET /
RMAN> CONNECT CATALOG rco@catdb

recovery catalog database Password: password

RMAN> CHANGE BACKUP TAG 'consistent_db_bkup' KEEP FOREVER;

```

### Example 2-48 Changing the Status of a Failure

In the following example, the `LIST FAILURE` command shows that a data file has corrupt blocks. The failure number is 5 and has a priority of `HIGH`. This data file contains nonessential data, so you decide to change the priority of this failure to low.

```

RMAN> LIST FAILURE;

List of Database Failures
Failure ID Priority Status      Time Detected Summary
-----
5          HIGH      OPEN      11-DEC-13  datafile 8 contains corrupt blocks

RMAN> CHANGE FAILURE 5 PRIORITY LOW;

List of Database Failures
Failure ID Priority Status      Time Detected Summary
-----
5          HIGH      OPEN      11-DEC-13  datafile 8 contains corrupt blocks

Do you really want to change the above failures (enter YES or NO)? YES
changed 1 failures to LOW priority

```

 **Note:**

Starting in Oracle Database 19c, the Data Recovery Advisor (DRA) feature is deprecated.

The deprecation of DRA includes deprecation of the following Oracle Recovery Manager (RMAN) commands: `LIST FAILURE`, `ADVISE FAILURE`, `REPAIR FAILURE`, and `CHANGE FAILURE`. Database administrators will no longer have access to these commands. There is no replacement feature for DRA.

### Example 2-49 Associating Backups with a New Database in a Data Guard Environment

Assume that `standby1`, `standby2`, and `standby3` are standby databases associated with primary database is `prod`. This example assumes that RMAN is connected to target database `prod` and a recovery catalog.

You are planning to remove `standby1` from your environment, so you want to associate the `standby1` backups with your primary database. You are also planning to remove `standby3` from your environment, so you want to associate the `standby3` backups with `standby2`. You execute the following commands:

```
CHANGE BACKUP FOR DB_UNIQUE_NAME standby1 RESET DB_UNIQUE_NAME;  
CHANGE BACKUP FOR DB_UNIQUE_NAME standby3 RESET DB_UNIQUE_NAME TO standby2;
```

### Example 2-50 Updating a DB\_UNIQUE\_NAME in the Recovery Catalog

Assume that a standby database has the `DB_UNIQUE_NAME` initialization parameter setting of `dgrdbms4`, which you decide to change to `sfrdbms4`. You shut down the standby instance, change the `DB_UNIQUE_NAME` initialization parameter to `sfrdbms4`, and restart the standby instance.

Later, to update the recovery catalog to reflect the changed unique name of the standby database, you connect RMAN to the primary database and recovery catalog, and then execute the `CHANGE` command as follows:

```
RMAN> CONNECT TARGET /  
RMAN> CONNECT CATALOG rco@catdb  
  
recovery catalog database Password: password  
  
RMAN> CHANGE DB_UNIQUE_NAME FROM dgrdbms4 TO sfrdbms4;
```

## 2.9 CONFIGURE

### Purpose

Use the `CONFIGURE` command to create or change a persistent configuration affecting RMAN backup, restore, duplication, and maintenance jobs on a particular database. A configuration is in effect for any RMAN session on this database until the configuration is explicitly cleared or changed. You can use the `SHOW` command to display the configurations for one or more databases.

 **See Also:**

*Oracle Database Backup and Recovery User's Guide* to learn how to configure the RMAN environment

### Additional Topics

- [Prerequisites](#)
- [Usage Notes](#)
- [Syntax](#)
- [Semantics](#)
- [Examples](#)

### Prerequisites

Execute this command only at the RMAN prompt.

Unless you specify the `FOR DB_UNIQUE_NAME` clause, an RMAN connection to a target database is required. The target database must be mounted or open.

In CDBs, you must connect to the root to create or change configuration settings. You cannot configure settings when connected to a PDB.

### Usage Notes

The `CONFIGURE` command always stores a configuration for a target database in the target database control file. If you use RMAN with a recovery catalog, then RMAN also stores persistent configuration settings for each registered database in the catalog.

### Default RMAN Configuration Settings

The RMAN `CONFIGURE` settings have defaults. You can return to the default for any `CONFIGURE` command by rerunning the command with the `CLEAR` option, but you cannot clear individual parameters in this way. For example, the following command is valid:

```
CONFIGURE CHANNEL DEVICE TYPE sbt CLEAR
```

However, the following command is invalid:

```
CONFIGURE CHANNEL DEVICE TYPE sbt MAXPIECESIZE 5M CLEAR
```

### RMAN Configuration in a Data Guard Environment

In a Data Guard environment, Oracle recommends that you always use RMAN with a recovery catalog. You can use the `CONFIGURE` command to create persistent RMAN configurations for any individual primary or standby database in the Data Guard environment, except settings for backup retention policy, tablespace exclusion, and auxiliary names. Thus, the primary and standby databases can have different channel configurations, control file autobackup locations, and so on.

You can use the `FOR DB_UNIQUE_NAME` clause to configure a database to which RMAN is not connected as `TARGET`. You can use `CONFIGURE DB_UNIQUE_NAME` to make a new physical standby database known to the recovery catalog and implicitly register it.

Syntax

**configure::=**

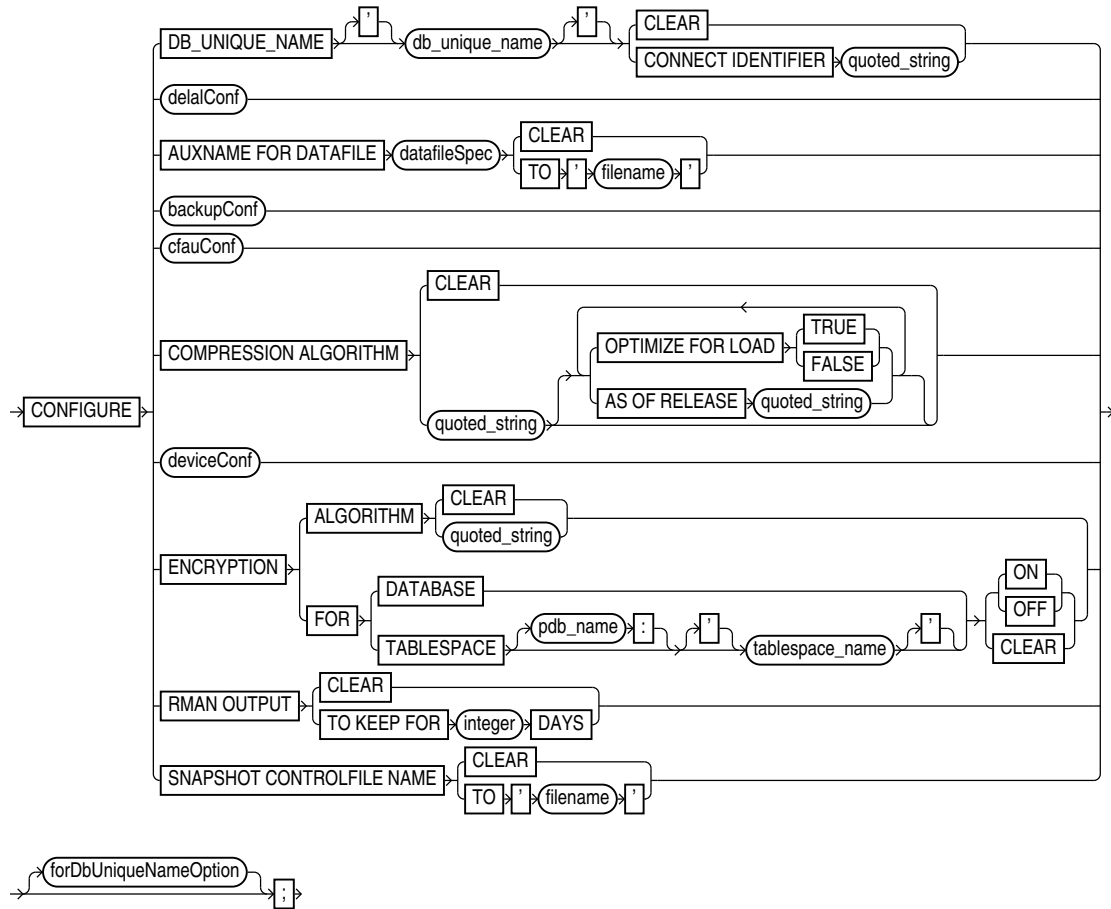

(datafileSpec::=, backupConf::=, cfauConf::=, deviceConf::=, forDbUniqueNameOption::=)

**delalConf::=**

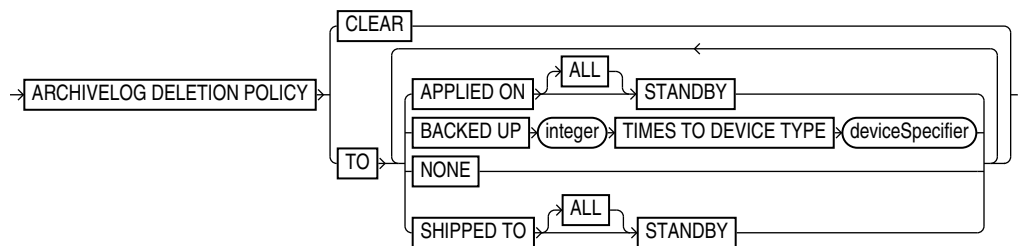

(deviceSpecifier::=)

**backupConf::=**

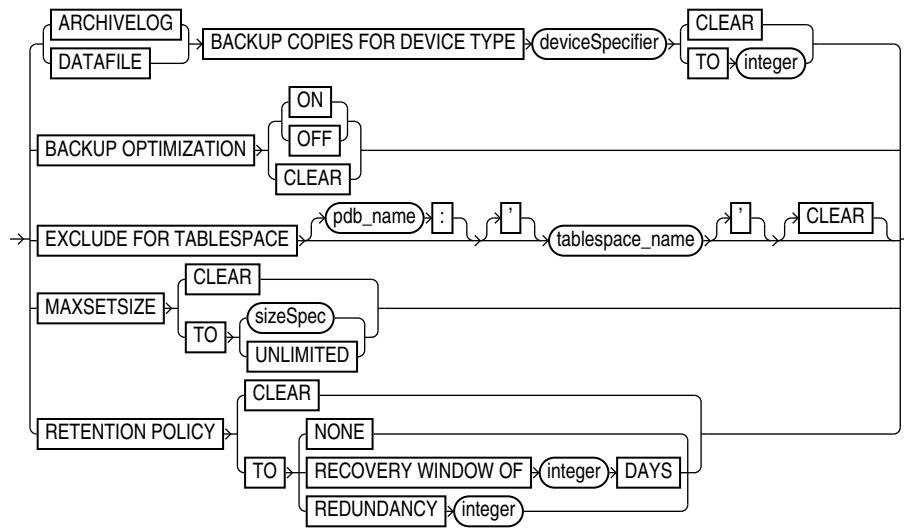

(deviceSpecifier::=, sizeSpec::=)

**cfauConf::=**

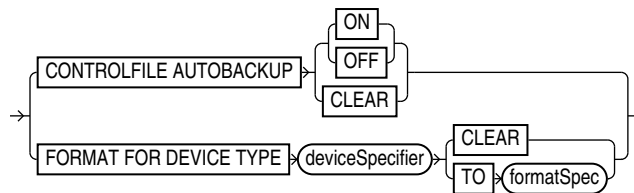

(deviceSpecifier::=, formatSpec::=)

**deviceConf::=**

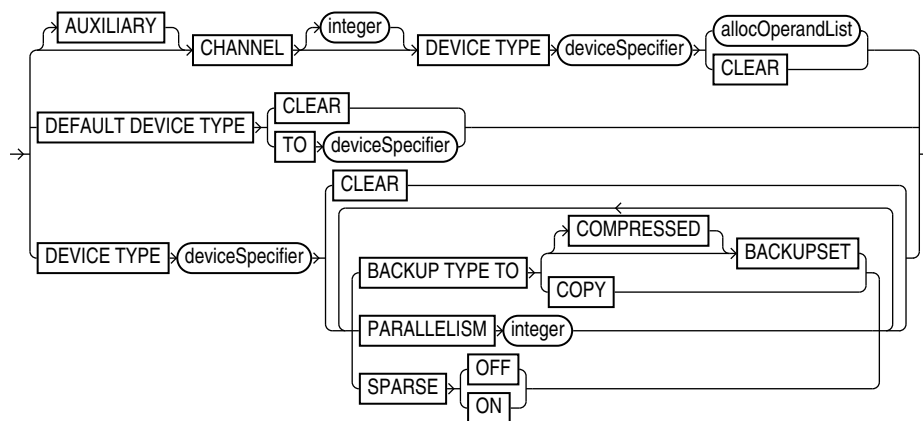

(deviceSpecifier::=, allocOperandList::=)

**forDbUniqueNameOption::=**

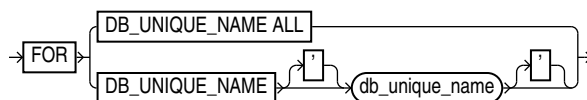

## Semantics

### *configure*

Syntax Element	Description
<code>DB_UNIQUE_NAME</code> <code>db_unique_name</code> <i>CONNECT IDENTIFIER</i> <code>'connect_string'</code>	<p>Specifies the net service name for the physical standby database specified by <code>DB_UNIQUE_NAME</code>. The <code>CONNECT IDENTIFIER</code> string must not include the database user name and password.</p> <p>RMAN must also be connected to the primary database as <code>TARGET</code>. RMAN must be connected to a recovery catalog.</p> <p>When you run the <code>RESYNC CATALOG FROM DB_UNIQUE_NAME</code> command, databases in a Data Guard environment use the net service name to connect with the <code>db_unique_name</code> database. For example, assume that a standby database has the unique name <code>standby1</code> and the net service name <code>sby1</code>. You connect RMAN as <code>TARGET</code> to the primary database and execute <code>CONFIGURE DB_UNIQUE_NAME 'standby1' CONNECT IDENTIFIER 'sby1'</code>. Every primary and standby database in the environment uses the net service name <code>sby1</code> when it needs to make an Oracle Net connection to <code>standby1</code>.</p> <p><b>Note:</b> When the target database needs to connect to other standby or primary databases, it connects as the <code>SYSDBA</code> or <code>SYSBACKUP</code> user by using the existing Data Guard authentication mechanisms.</p> <p>Suppose that you recently connected RMAN as <code>TARGET</code> to the primary database and used <code>CONFIGURE ... FOR DB_UNIQUE_NAME standby_new</code> to configure backup settings for standby database <code>standby_new</code>. However, you have not yet connected RMAN as <code>TARGET</code> to <code>standby_new</code>. In this case, you can execute <code>RESYNC CATALOG FROM DB_UNIQUE_NAME standby_new</code>. The primary database uses the connect identifier to make an Oracle Net connection to the standby database. When you later connect RMAN to the standby database, RMAN pushes the configuration from the recovery catalog to the mounted control file.</p> <p><b>Note:</b> If the database specified by <code>CONFIGURE DB_UNIQUE_NAME</code> is not registered in the recovery catalog, then RMAN implicitly registers it.</p>
<code>CLEAR</code>	Returns a parameter to its default setting. See the Usage Notes.
<code>delalConf</code>	Configures an archived redo log deletion policy.

Syntax Element	Description
<code>AUXNAME FOR DATAFILE datafileSpec CLEAR   TO 'filename'</code>	<p>Configures the auxiliary file name for the specified target data file to <i>'filename'</i> (see <a href="#">Example 2-55</a>). Specify <code>CLEAR</code> to unspecify the auxiliary file name.</p> <p>If you are performing TSPITR or using <a href="#">DUPLICATE</a>, then you can set <code>AUXNAME</code> to preconfigure the file names for use on the auxiliary database without manually specifying the auxiliary file names during the procedure. You cannot use <code>CONFIGURE AUXNAME</code> for recovery set, you must use <code>SET NEWNAME</code>.</p> <p>For example, use this command during TSPITR if the data files are on raw disk and you must restore auxiliary data files to raw disk for performance reasons. Typically, you set the <code>AUXNAME</code> parameter in TSPITR for the data files of the <code>SYSTEM</code> and <code>SYSAUX</code> tablespaces and the tablespaces containing rollback or undo segments. Do not overlay files which are in use by the production database and can be discarded after TSPITR completes. In essence, the <code>AUXNAME</code> of a data file is the location where TSPITR can create a temporary copy of it.</p> <p>When renaming files with the <code>DUPLICATE</code> command, <code>CONFIGURE AUXNAME</code> is an alternative to <code>SET NEWNAME</code>. The difference is that after you set the <code>AUXNAME</code> the first time, you do not need to reset the file name when you issue another <code>DUPLICATE</code> command: the <code>AUXNAME</code> setting remains in effect until you issue <code>CONFIGURE AUXNAME . . . CLEAR</code>. In contrast, you must reissue the <code>SET NEWNAME</code> command every time you execute the <code>DUPLICATE</code> command.</p> <p><b>See Also:</b> <i>Oracle Database Backup and Recovery User's Guide</i> to learn how to perform RMAN TSPITR, and <i>Oracle Database Backup and Recovery User's Guide</i> to learn how to duplicate a database with RMAN</p>
<code>backupConf</code>	Configures default backup options such as duplexing, optimization, excluding tablespaces, backup set sizes, and retention policies.
<code>cfauConf</code>	Configures control file autobackup settings.

Syntax Element	Description
<pre>COMPRESSION ALGORITHM 'algorithm_name'</pre>	<p>Specifies the algorithm that RMAN uses to create compressed backup sets. The default compression algorithm setting is <code>BASIC</code> and does not require the Advanced Compression Option.</p> <p>If, however, you have enabled the Advanced Compression Option, you can choose from the following compression levels:</p> <ul style="list-style-type: none"> <li>• <code>HIGH</code> - Best suited for backups over slower networks where the limiting factor is network speed</li> <li>• <code>MEDIUM</code> - Recommended for most environments. Good combination of compression ratios and speed</li> <li>• <code>LOW</code> - Least impact on backup throughput and suited for environments where CPU resources are the limiting factor.</li> </ul> <p><b>Note:</b> The compression ratio generally increases from <code>LOW</code> to <code>HIGH</code>, with a trade-off of potentially consuming more CPU resources.</p> <p>Since the performance of the various compression levels depends on the nature of the data in the database, network configuration, system resources and the type of computer system and its capabilities, Oracle cannot document universally applicable performance statistics. The decision about which level is best must factor in on how balanced your system is regarding bandwidth into the CPU and the actual speed of the CPU. It is highly recommended that you run tests with the different compression levels on the data in your environment. Choosing a compression level based on your environment, network traffic characteristics (workload) and data set is the only way to ensure that the backup set compression level can satisfy your organization's performance requirements and any applicable service level agreements.</p> <p><b>Note:</b> The <code>V\$RMAN_COMPRESSION_ALGORITHM</code> view describes the supported algorithms.</p> <p><b>See Also:</b> <i>Oracle Database Reference</i> entry for <code>V\$RMAN_COMPRESSION_ALGORITHM</code>.</p>
<pre>OPTIMIZE FOR LOAD {TRUE FALSE}</pre>	<p>Specifies whether Oracle Database performs pre-compression block processing when compressed backups have been requested. <code>TRUE</code> is the default and <code>FALSE</code> enables pre-compression processing. The default behavior is not to perform pre-compression block processing. Such processing can consume extra CPU resources, and is not needed for blocks that contain all originally loaded data, and have never been the subject of single-row inserts and deletes. Specifying <code>FALSE</code> uses additional CPU resources to perform pre-compression block processing which consists of internal block cleanups and defragmentation that can result in improved levels of binary compression.</p> <p><b>See Also:</b> <i>Oracle Database Backup and Recovery User's Guide</i> to learn more about this option.</p>
<pre>AS OF RELEASE 'version'</pre>	<p>Specifies the release version. The version number uses the release number format and may use as many as 5 numbers to fully qualify the release. For example, 10.2.0.3.0 and 11.2 are acceptable values. This option ensures compression algorithm stability across future releases.</p>
<pre>deviceConf</pre>	<p>Configures default backup settings for devices, such as the default backup device, channel configurations for devices, default backup types for each device, and parallelism.</p>



Syntax Element	Description
ENCRYPTION	<p>Specifies transparent-mode encryption settings for the database or tablespaces. This configuration applies unless overridden with the <code>SET ENCRYPTION</code> command. Options specified for an individual tablespace take precedence over options specified for the whole database.</p> <p><b>See Also:</b> "Encryption of Backup Sets" to learn about the different modes of backup encryption, and <i>Oracle Database Advanced Security Guide</i> to learn about transparent data encryption</p>
<pre>ALGORITHM 'algorithm_name'</pre>	<p>Specifies the default algorithm to use for encryption when writing backup sets. Possible values are listed in <code>V\$RMAN_ENCRYPTION_ALGORITHMS</code>. The <code>CLEAR</code> option resets the database to the default value.</p>
<pre>FOR DATABASE [ON   OFF   CLEAR]</pre>	<p>Specifies whether to enable transparent encryption for the entire database. The options are as follows:</p> <ul style="list-style-type: none"> <li>• <code>ON</code> enables encryption for all database files.</li> <li>• <code>OFF</code> turns off encryption for all database files.</li> <li>• <code>CLEAR</code> restores the default setting of <code>OFF</code>.</li> </ul> <p><b>Note:</b> You must use the <code>SET ENCRYPTION IDENTIFIED BY</code> command to enable password encryption.</p>
<pre>FOR TABLESPACE tablespace_name [ON   OFF   CLEAR]</pre>	<p>Specifies whether to enable transparent encryption for one or more tablespaces. Configured settings for a tablespace always override configuration set at the database level. The options are as follows:</p> <ul style="list-style-type: none"> <li>• <code>ON</code> enables encryption for the specified tablespace unless <code>SET ENCRYPTION OFF FOR ALL TABLESPACES</code> is used.</li> <li>• <code>OFF</code> disables encryption for the specified tablespace unless <code>SET ENCRYPTION ON FOR ALL TABLESPACES</code> is used.</li> <li>• <code>CLEAR</code> means that encryption for the specified tablespace is determined by the current default for the whole database.</li> </ul> <p><b>Note:</b> You must use the <code>SET ENCRYPTION IDENTIFIED BY</code> command to enable password encryption.</p>
<pre>FOR TABLESPACE pdb_name:tablespace_name [ON   OFF   CLEAR]</pre>	<p>The name of the tablespace in a CDB. Multiple databases can have tablespaces with the same name. A qualifier before the name uniquely identifies the tablespace. <code>pdb-name</code> is the name of a PDB.</p> <p>See the previous description of <code>FOR TABLESPACE</code>.</p>
<pre>RMAN OUTPUT TO KEEP FOR integer DAYS</pre>	<p>Configures RMAN output logging to the number of days specified by <code>integer</code>. Information regarding the output of RMAN commands is stored in two views, <code>RC_RMAN_OUTPUT</code> and <code>V\$RMAN_OUTPUT</code>. When you configure output logging to <code>integer days</code>, any logging entry that is older than <code>integer days</code> is deleted from both the <code>RC_RMAN_OUTPUT</code> and <code>V\$RMAN_OUTPUT</code> views.</p> <p>For example, assume that the existing output logging configuration is set to 20 days. You use the <code>CONFIGURE</code> command to change output logging to 10 days. Any logging entries that are older than 10 days are deleted from <code>RC_RMAN_OUTPUT</code> and <code>V\$RMAN_OUTPUT</code>.</p> <p>To disable RMAN output logging, set <code>integer</code> to zero, as shown in the following example.</p> <pre>CONFIGURE RMAN OUTPUT TO KEEP FOR 0 DAYS;</pre> <p>When you disable output logging, no logging information is stored in the <code>RC_RMAN_OUTPUT</code> and <code>V\$RMAN_OUTPUT</code> views. Existing logging entries in <code>RC_RMAN_OUTPUT</code> are deleted.</p>

Syntax Element	Description
CLEAR	<p>Clears the existing RMAN output logging configuration and resets it to 7 days, which is the default.</p> <p>RMAN stores output logging information in the <code>RC_RMAN_OUTPUT</code> and <code>V\$RMAN_OUTPUT</code> views. When you clear the output logging configuration, any logging entry that is older than 7 days (the default value) is deleted from the <code>RC_RMAN_OUTPUT</code> view. Entries older than 7 days in the <code>V\$RMAN_OUTPUT</code> view are not deleted immediately. They are deleted only when the maximum number of rows permitted for this view is exceeded.</p>
SNAPSHOT CONTROLFILE NAME TO ' <i>filename</i> '	<p>Configures the snapshot control file name and location to '<i>filename</i>'. If you run <code>CONFIGURE SNAPSHOT CONTROLFILE NAME CLEAR</code>, then RMAN sets the snapshot control file name to its default.</p> <p>The default value for the snapshot control file name is platform-specific and dependent on Oracle home. For example, the default on some UNIX systems is <code>~/dbs/snapcf_@.f</code>. If you clear the control file name, and if you change Oracle home, then the default location of the snapshot control file changes as well.</p> <p>The snapshot control file name is valid for this database only. Assume that you configure the snapshot control file name to a nondefault value on the primary database. If you use <a href="#">DUPLICATE</a> to create a standby database, then the snapshot control file location on the standby database is set to the default value. If desired, you can then configure the snapshot location on the standby database to a nondefault value.</p> <p><b>See Also:</b> <i>Oracle Database Backup and Recovery User's Guide</i> for more information about snapshot control files</p>
<a href="#">forDbUniqueNameOption</a>	<p>Creates an RMAN configuration in the recovery catalog for the database in a Data Guard environment specified by <code>DB_UNIQUE_NAME</code>. You can specify a single database with <code>db_unique_name</code> or use <code>ALL</code> for all databases in the recovery catalog that share the DBID of the target database (or DBID specified by the <a href="#">SET DBID</a> command).</p> <p>A recovery catalog is required when performing operations in a Data Guard environment. RMAN must be connected as <code>TARGET</code> to a mounted or open database (which can be a primary or standby database), or you must identify the target database with the <a href="#">SET DBID</a> command. Thus, you can use this clause to create a persistent configuration for a standby database <i>without</i> connecting as <code>TARGET</code> to the standby or primary database. For example, you can create a configuration for a standby database before its creation so that the configuration applies after the database is created (see <a href="#">Example 2-57</a>).</p> <p>When you specify <code>FOR DB_UNIQUE_NAME</code>, RMAN directly updates the configuration metadata in the recovery catalog. When RMAN connects as <code>TARGET</code> to a database whose configurations were changed with <code>FOR DB_UNIQUE_NAME</code>, RMAN updates the mounted control file with the configuration metadata from the recovery catalog.</p> <p><b>Note:</b> It is possible to run <code>CONFIGURE</code> locally on a standby database and then run <code>CONFIGURE FOR DB_UNIQUE_NAME</code> for the same database while RMAN is not connected to this database as <code>TARGET</code>. In this case, the configuration in the recovery catalog overrides the configuration in the control file for the specific database.</p>

***delalConf***

This subclause manages persistent configurations for archived redo log deletion policy.

Syntax Element	Description
<code>ARCHIVELOG DELETION POLICY</code>           <code>TO APPLIED ON [ALL] STANDBY</code>	<p>Determines when archived redo log files are eligible for deletion.</p> <p>The archived log deletion policy applies to all log archiving destinations, including the fast recovery area. The policy does not apply to archived redo log files in backup sets.</p> <p>Only archived redo log files in the fast recovery area are automatically deleted by the database. You can execute the <code>BACKUP ... DELETE INPUT</code>, <code>DELETE ARCHIVELOG</code>, or <code>DELETE OBSOLETE</code> commands to delete logs manually from log archiving destinations, including the recovery area. If <code>FORCE</code> is not specified on the deletion commands, then these deletion commands obey the archived log deletion policy. If <code>FORCE</code> is specified, then the deletion commands ignore the archived log deletion policy.</p> <p>In the recovery area, the database retains logs eligible for deletion if possible. The database deletes the oldest logs first when disk space is required. When the recovery area is under disk pressure, the database may delete archived redo log files that are reclaimable according to the fast recovery area rules.</p> <p><b>Note:</b> The deletion policy does not apply to foreign archived redo log files, which are logs received by a logical standby database for a LogMiner session. These logs are transferred from a primary database, but unlike ordinary archived redo log files they have a different DBID. Foreign archived redo log files cannot be backed up or restored on a logical standby database.</p> <p>Archived redo log files are eligible for deletion if <i>both</i> of the following conditions are met:</p> <ul style="list-style-type: none"><li>• The archived redo log files have been applied to the required standby databases.</li><li>• The logs are not needed by the <code>BACKED UP ... TIMES TO DEVICE TYPE</code> deletion policy. If the <code>BACKED UP</code> policy is not set, then this condition is always met.</li></ul> <p>When valid standby remote databases exist, this policy is applicable to primary databases, standby databases, and <code>FAR SYNC</code> standby databases.</p> <p>For primary databases, the archived redo log files are eligible for deletion after they are applied on the standby. If no valid standby database exists, then <code>RMAN</code> uses <code>TO NONE</code> as the policy. For standby databases, the archived redo log files are eligible for deletion after they are applied on the standby database and on any cascading standby databases.</p> <p>Which remote destinations are considered depends on the following criteria:</p> <ul style="list-style-type: none"><li>• If you do not specify <code>ALL</code>, then archived redo log files are eligible for deletion after being applied to all mandatory remote destinations.</li><li>• If you specify <code>ALL</code>, then archived redo log files are eligible after being applied or consumed on all remote destinations, whether mandatory or not.</li></ul> <p>For example, standby database <code>sby1</code> may be the only remote destination receiving logs, but other remote destinations may apply logs by referring to the same location on <code>sby1</code>. With <code>ALL</code>, <code>sby1</code> marks the log on the primary database as consumed as soon as it is not required at <code>sby1</code>, but does not permit deletion of this log until it is applied or consumed by all other dependent remote destinations referring to the same location.</p> <p><b>Note:</b> It is invalid to specify the <code>TO APPLIED</code> clause in combination with either <code>NONE</code> or the <code>TO SHIPPED</code> clause.</p> <p><b>See Also:</b> <i>Oracle Data Guard Concepts and Administration</i> for details</p>

Syntax Element	Description
BACKED UP <i>integer</i> TIMES TO DEVICE TYPE <a href="#">deviceSpecifier</a>	<p>Archived redo log files are eligible for deletion if <i>both</i> of the following conditions are met:</p> <ul style="list-style-type: none"> <li>The specified number of archived log backups exist on the specified device type.</li> <li>The logs are not needed by the TO SHIPPED TO ... STANDBY or TO APPLIED ON ... STANDBY deletion policy. If the TO SHIPPED TO policy is not set, then this condition is always met.</li> </ul> <p>If you configure the deletion policy with this clause, then a BACKUP ARCHIVELOG command copies the logs unless <i>integer</i> backups exist on the specified device type. If <i>integer</i> backups of the logs exist, then the BACKUP ARCHIVELOG command skips the logs. In this way, the archived log deletion policy functions as a default NOT BACKED UP <i>integer</i> TIMES clause on the BACKUP ARCHIVELOG command. You can override this deletion policy by specifying FORCE option on the BACKUP command.</p> <p><b>See Also:</b> <a href="#">deviceSpecifier</a></p>
TO NONE	<p>Disables the archived log deletion policy. This is the default setting.</p> <p>Archived redo log files can be located inside or outside of the fast recovery area. Logs in any location can be deleted by manual commands. Only logs in the fast recovery area can be deleted automatically by the database.</p> <ul style="list-style-type: none"> <li>When remote destinations are configured for the target database, archived redo log files, whether in the fast recovery area or outside of it, are eligible for deletion if have been transferred to the required remote destinations specified by LOG_ARCHIVE_DEST_ <i>n</i>.</li> <li>When no remote destinations are configured, archived redo log files in the fast recovery area are eligible for deletion if they have been backed up at least once to disk or SBT or the logs are obsolete according to the backup retention policy.</li> </ul> <p>The backup retention policy considers logs obsolete <i>only if</i> the logs are not needed by a guaranteed restore point <i>and</i> the logs are not needed by Flashback Database. Archived redo log files are needed by Flashback Database if the logs were created later than  <code>SYSDATE-'DB_FLASHBACK_RETENTION_TARGET'</code>.</p> <p>For example, suppose that archived redo log files have been transferred to required remote destinations. The logs are obsolete according to the recovery window retention policy, but have not been backed up. In this case, the logs are eligible for deletion. Alternatively, suppose that the logs are obsolete and have been backed up to SBT, but have <i>not</i> been transferred to required remote destinations. In this case, the logs are not eligible for deletion.</p> <p>If the deletion policy is set to NONE, and if you execute a deletion command for archived redo log files outside the fast recovery area, then RMAN obeys only the conditions specified on the deletion command.</p>

Syntax Element	Description
TO SHIPPED TO [ALL] STANDBY	<p>Archived redo log files are eligible for deletion if <i>both</i> of the following conditions are met:</p> <ul style="list-style-type: none"> <li>The archived redo log files have been transferred to the required remote destinations.</li> <li>The logs are not needed by the <code>BACKED UP ... TIMES TO DEVICE TYPE</code> deletion policy. If the <code>BACKED UP</code> deletion policy is not set, then this condition is always met.</li> </ul> <p>When valid standby remote databases exist, this policy is applicable to primary databases, standby databases, and <code>FAR SYNC</code> standby databases.</p> <ul style="list-style-type: none"> <li>For primary databases: <ul style="list-style-type: none"> <li>If valid standby configurations exist, then the archived redo log files are eligible for deletion after they are shipped to the standby.</li> <li>If no valid standby database exists, then RMAN uses <code>TO NONE</code> as the default policy.</li> </ul> </li> <li>For standby databases: <ul style="list-style-type: none"> <li>If valid cascading standby configurations exist, then the archived redo log files are eligible for deletion after they are shipped to the cascading standby database.</li> <li>If no valid cascading standby configurations exist, then RMAN uses <code>TO NONE</code> as the default policy.</li> </ul> </li> </ul> <p>Which remote destinations are considered depends on the following criteria:</p> <ul style="list-style-type: none"> <li>If you do not specify <code>ALL</code>, then the archived redo log files are eligible for deletion after transfer to mandatory remote destinations only.</li> <li>If you specify <code>ALL</code>, then the logs are eligible for deletion after transfer to all remote destinations, whether mandatory or not.</li> </ul> <p><b>Note:</b> It is invalid to specify the <code>TO SHIPPED</code> clause in combination with <code>NONE</code> or the <code>TO APPLIED</code> clause.</p> <p><b>See Also:</b> <i>Oracle Data Guard Concepts and Administration</i> for details</p>

### **backupConf**

This subclause manages persistent configurations relating to the `BACKUP` command. One configuration is backup optimization. If you enable backup optimization, then RMAN does not back up a file to a device type if the identical file is already backed up on the device type.

[Table 2-3](#) explains the criteria used by backup optimization to determine whether a file is identical and can potentially be skipped. The table also explains the algorithm that RMAN uses when backup optimization is enabled and it needs to determine whether to skip the backup of an identical file. If RMAN does not skip a backup, then it makes the backup exactly as specified.

Table 2-3 Backup Optimization Algorithm

File Type	Criteria for an Identical File	Backup Algorithm When Backup Optimization Is Enabled
Data file	The data file must have the same DBID, checkpoint SCN, creation SCN, and <code>RESETLOGS</code> SCN and time as a data file already in a backup. The data file must be offline-normal, read-only, or closed normally.	<p>If a recovery window-based retention policy is enabled, then whether RMAN skips a data file depends on the backup media.</p> <p>For backups to tape, if the most recent backup is older than the recovery window, then RMAN takes another backup of a data file even if a backup of an identical data file exists. In this way, tapes can be recycled after they expire.</p> <p>For backups to disk, RMAN skips the backup if an identical data file is available on disk, even if that backup is older than the beginning of the recovery window. The window-based retention policy causes RMAN to retain the old backup if it is needed.</p> <p>If a retention policy is enabled with <code>CONFIGURE RETENTION POLICY TO REDUNDANCY <math>r</math></code>, then RMAN skips backups only if at least <math>n</math> backups of an identical file exist on the specified device, where <math>n=r+1</math>.</p> <p>If no retention policy is enabled, then RMAN skips a backup only if at least <math>n</math> backups of an identical file exist on the specified device. RMAN searches for values of <math>n</math> in this order of precedence (that is, values higher on the list override values lower on the list):</p> <ol style="list-style-type: none"> <li>1. <code>BACKUP ... COPIES <math>n</math></code></li> <li>2. <code>SET BACKUP COPIES <math>n</math></code></li> <li>3. <code>CONFIGURE DATAFILE BACKUP COPIES FOR DEVICE TYPE ... TO <math>n</math></code></li> <li>4. <math>n=1</math></li> </ol>
Archived redo log	The archived redo log must have the same thread, sequence number, and <code>RESETLOGS</code> SCN and time as an archived log already in a backup.	<p>RMAN skips a backup only if at least <math>n</math> backups of an identical file exist on the specified device. RMAN searches for values of <math>n</math> in this order of precedence (that is, values higher on the list override values lower on the list):</p> <ol style="list-style-type: none"> <li>1. <code>BACKUP ... COPIES <math>n</math></code></li> <li>2. <code>SET BACKUP COPIES <math>n</math></code></li> <li>3. <code>CONFIGURE ARCHIVELOG BACKUP COPIES FOR DEVICE TYPE ... TO <math>n</math></code></li> <li>4. <math>n=1</math></li> </ol>
Backup set	The backup set must have the same record ID and stamp as an existing backup set.	<p>RMAN skips a backup only if at least <math>n</math> backups of an identical file exist on the specified device. By default, <math>n=1</math>. RMAN searches for other values of <math>n</math> in this order of precedence (that is, values higher on the list override values lower on the list):</p> <ol style="list-style-type: none"> <li>1. <code>BACKUP ... COPIES <math>n</math></code></li> <li>2. <code>SET BACKUP COPIES <math>n</math></code></li> <li>3. <math>n=1</math></li> </ol>

Syntax Element	Description
<pre>{ARCHIVELOG   DATAFILE} BACKUP COPIES FOR DEVICE TYPE deviceSpecifier TO integer</pre>	<p>Specifies the number of copies of each backup set for <code>DATAFILE</code> (both data files and control files) or <code>ARCHIVELOG</code> files on the specified device type (see <a href="#">Example 2-52</a>). You can create from 1 (default) to 4 copies.</p> <p>RMAN can duplex backups to either disk or tape, but cannot duplex backups to tape and disk simultaneously. When backing up to tape, ensure that the number of copies does not exceed the number of available tape devices. Also, if <code>COPIES</code> is greater than 1, then the <code>BACKUP_TAPE_IO_SLAVES</code> initialization parameter must be enabled on the target database.</p> <p>Control file autobackups are never duplexed. Also, duplexing is not permitted in the fast recovery area.</p> <p>If duplexing is specified in the <code>BACKUP</code> command or in a <code>SET BACKUP COPIES</code> command, then the <code>CONFIGURE</code> setting is overridden.</p>
<pre>BACKUP OPTIMIZATION [ON   OFF   CLEAR]</pre>	<p>Toggles backup optimization <code>ON</code> or <code>OFF</code> (default). Specify <code>CLEAR</code> to return optimization to its default value of <code>OFF</code>.</p> <p>Backup optimization is enabled when all of the following conditions are met:</p> <ul style="list-style-type: none"> <li>The <code>CONFIGURE BACKUP OPTIMIZATION ON</code> command has been run.</li> <li>You run <code>BACKUP DATABASE, BACKUP ARCHIVELOG</code> with the <code>ALL</code> or <code>LIKE</code> options, <code>BACKUP BACKUPSET ALL</code>, <code>BACKUP RECOVERY AREA</code>, <code>BACKUP RECOVERY FILES</code>, or <code>BACKUP DATAFILECOPY</code>.</li> <li>The RMAN job uses a channel of only one device type.</li> </ul> <p>Optimization prevents RMAN from backing up a file to a device type if the identical file is already backed up on the device type. RMAN does not signal an error if backup optimization causes all files to be skipped during a backup. The backup retention policy affects which files backup optimization skips.</p> <p>For two files to be identical, their content must meet the requirements described in <a href="#">Table 2-3</a>. When you create backup pieces on disk or on media managed by Oracle Secure Backup, optimization excludes undo data from the backup when the data does not belong to an active transaction.</p> <p><b>Note:</b> <code>BACKUP ... DELETE INPUT</code> deletes all specified archived redo log whether or not optimization would skip these files during a backup.</p> <p><b>Note:</b> You can override backup optimization with the <code>FORCE</code> option of the <code>BACKUP</code> command.</p> <p><b>See Also:</b> <i>Oracle Database Backup and Recovery User's Guide</i> for a description of how RMAN determines that it can skip the backup of a file</p>
<pre>EXCLUDE FOR TABLESPACE tablespace_name [CLEAR]</pre>	<p>Excludes the specified tablespace from <code>BACKUP DATABASE</code> and <code>RESTORE DATABASE</code> commands (see <a href="#">Example 2-54</a>). You cannot exclude the <code>SYSTEM</code> tablespace.</p> <p>The <code>BACKUP</code> command default does not exclude tablespaces. You must declare the option to use it. The exclusion is stored as an attribute of the tablespace and not to the individual data files. In this manner, the exclusion applies not only to the present set of data files but also to any files that are added to this tablespace in the future. If you run <code>CONFIGURE ... CLEAR</code> on a tablespace after excluding it, then it returns to the default configuration of nonexclusion.</p> <p>You can still back up an excluded tablespace by explicitly specifying it in a <code>BACKUP</code> command or by specifying the <code>NOEXCLUDE</code> option on a <code>BACKUP DATABASE</code> command. Similarly, you can restore an excluded tablespace by specifying it in the <code>RESTORE TABLESPACE</code> command.</p>

Syntax Element	Description
EXCLUDE FOR TABLESPACE <i>pdb_name:tablespace_name</i> [CLEAR]	<p>The name of the tablespace in a PDB. Multiple PDBs can have tablespaces with the same name. A qualifier before the name uniquely identifies the tablespace. <i>pdb-name</i> is the name of a PDB.</p> <p>See the previous description of EXCLUDE FOR TABLESPACE.</p>
MAXSETSIZE	<p>Specifies the maximum size of each backup set created on a channel. Use the CLEAR option to return MAXSETSIZE to the default value of UNLIMITED.</p> <p><b>Note:</b> This option is ignored by BACKUP AS COPY.</p>
TO <i>sizeSpec</i>	<p>Specifies the maximum size of each backup set as <i>integer</i> gigabytes, kilobytes, or megabytes.</p>
TO UNLIMITED	<p>Specifies no size limit for backup sets.</p>
RETENTION POLICY	<p>Specifies a persistent, ongoing policy for backup sets and copies that RMAN marks as obsolete, that is, not needed and eligible for deletion.</p> <p>As time passes, RMAN marks backup sets and copies as obsolete according to the criteria specified in the retention policy. RMAN automatically deletes obsolete backup sets and copies in the fast recovery area when space is needed. RMAN does not automatically delete obsolete files outside the fast recovery area: you must manually execute DELETE OBSOLETE to remove them.</p> <p>For backups, the basic unit of the retention policy is a backup set (not a backup piece) or image copy. For example, BACKUP AS BACKUPSET COPIES 4 TABLESPACE <i>users</i> creates a single backup set that is duplexed into four identical backup pieces. The retention policy considers this as <i>one</i> backup, not four separate backups.</p> <p><b>Note:</b> Use the CLEAR option to return RETENTION POLICY to its default of REDUNDANCY 1.</p>
TO NONE	<p>Disables the retention policy feature. RMAN does not consider any backup sets or copies as obsolete.</p>
TO RECOVERY WINDOW OF <i>integer</i> DAYS	<p>Specifies a time window in which RMAN can recover the database.</p> <p>The window stretches from the current time (SYSDATE) to the point of recoverability, which is the earliest date to which you want to recover. The point of recoverability is SYSDATE - <i>integer</i> days in the past. Use this setting to restore or recover dropped tablespaces or data files.</p> <p><b>Note:</b> The REDUNDANCY and RECOVERY WINDOW options are mutually exclusive. Only one type of retention policy can be in effect at any time.</p>



Syntax Element	Description
<code>TO REDUNDANCY integer</code>	<p>Retains <i>integer</i> full or level 0 backups of each data file and control file. The default retention policy setting is <code>REDUNDANCY 1</code>. This setting considers only the current set of data files.</p> <p>If more than <i>integer</i> full or level 0 backups of a data file or control file exist, then RMAN marks these extra files as obsolete. RMAN then determines the oldest of the retained backups and marks all archived redo log files and log backups older than this backup as obsolete. The <code>DELETE OBSOLETE</code> command removes obsolete data file backups (full or incremental), control file backups, and archived log backups or image copies.</p> <p>The following scenario illustrates how redundancy works in an incremental backup strategy. Assume that the redundancy level is 1. You run a level 0 database backup at noon Monday, a level 1 cumulative backup at noon on Tuesday and Wednesday, and a level 0 backup at noon on Thursday. Immediately after each daily backup you run a <code>DELETE OBSOLETE</code>. The Wednesday <code>DELETE</code> command does not remove the Tuesday level 1 backup because this backup is not redundant: the Tuesday level 1 backup could be used to recover the Monday level 0 backup to a time between noon on Tuesday and noon on Wednesday. However, the <code>DELETE</code> command on Thursday removes the previous level 0 and level 1 backups.</p> <p><b>Note:</b> The <code>REDUNDANCY</code> and <code>RECOVERY WINDOW</code> options are mutually exclusive. Only one type of retention policy can be in effect at any time.</p>

### *cfauConf*

This subclause creates persistent configurations relating to control file autobackups.

Syntax Element	Description
<code>CONTROLFILE AUTOBACKUP</code>	<p>Controls the control file autobackup feature.</p> <p>By default, control file autobackup is turned on when the <code>COMPATIBLE</code> initialization parameter is set to 12.2 or higher.</p> <p><b>Note:</b> Oracle recommends that you enable the control file autobackup feature.</p>

Syntax Element	Description
ON	<p>Performs a control file autobackup in the following circumstances:</p> <ul style="list-style-type: none"> <li>• After every <code>BACKUP</code> or <code>CREATE CATALOG</code> command issued at the RMAN prompt.</li> <li>• Whenever a <code>BACKUP</code> command within a <code>RUN</code> block is followed by a command that is not <code>BACKUP</code>.</li> <li>• At the end of every <code>RUN</code> block if the last command in the block was <code>BACKUP</code>.</li> <li>• After structural changes for databases in <code>ARCHIVELOG</code> mode. The autobackup after structural changes does not occur for databases in <code>NOARCHIVELOG</code> mode.</li> </ul> <p>Structural changes include adding tablespaces, altering the state of a tablespace or data file (for example, bringing it online), adding a new online redo log, renaming a file, adding a new redo thread, enabling or disabling Flashback Database, and so on. This type of autobackup, unlike autobackups that occur in the preceding circumstances, is only to disk. You can run <code>CONFIGURE CONTROLFILE AUTOBACKUP FOR DEVICE TYPE DISK</code> to set a nondefault disk location.</p> <p>Starting with Oracle 11g Release 2, RMAN creates a single autobackup file encompassing all of the structural changes that have occurred within a few minutes of each other rather than creating a new backup of the controlfile on each structural change to the database.</p> <p>The first channel allocated during the backup or copy job creates the autobackup and places it into its own backup set; for post-structural autobackups, the default disk channel makes the backup. RMAN writes the control file and server parameter file to the same backup piece. After the control file autobackup completes, the database writes a message containing the complete path of the backup piece and the device type to the alert log.</p> <p>The default location for the autobackup on disk is the fast recovery area (if configured) or a platform-specific location (if not configured). RMAN automatically backs up the current control file using the default format of <code>%F</code>. You can change the location and file name format with the <code>CONFIGURE CONTROLFILE AUTOBACKUP FORMAT</code> and <code>SET CONTROLFILE AUTOBACKUP FORMAT</code> commands.</p> <p>You cannot configure RMAN to write the autobackup to multiple locations. To create multiple control file backups, you can make the last command in your backup job a <code>BACKUP CURRENT CONTROLFILE FORMAT</code> command, which backs up the control file to the specified <code>FORMAT</code> location and then executes an autobackup.</p> <p><b>Note:</b> The <code>SET CONTROLFILE AUTOBACKUP FORMAT</code> command, which you can specify either within a <code>RUN</code> block or at the RMAN prompt, overrides the configured autobackup format in the session only. The order of precedence is:</p> <ol style="list-style-type: none"> <li>1. <code>SET</code> within a <code>RUN</code> block</li> <li>2. <code>SET</code> at RMAN prompt</li> <li>3. <code>CONFIGURE CONTROLFILE AUTOBACKUP FORMAT</code></li> </ol> <p>You can configure the autobackup format even when <code>CONFIGURE CONTROLFILE AUTOBACKUP</code> is set to <code>OFF</code>, but RMAN does not generate autobackups in this case. For RMAN to make autobackups, you must set <code>CONFIGURE CONTROLFILE AUTOBACKUP</code> to <code>ON</code>.</p>
OFF	<p>Disables the autobackup feature.</p> <p>Any <code>BACKUP</code> command that includes data file 1 automatically includes the current control file and server parameter file in the backup set. Otherwise, RMAN does not include these files.</p>

Syntax Element	Description
CLEAR	Returns this configuration to its default setting of ON.
FORMAT FOR DEVICE TYPE <i>deviceSpecifier</i> TO <i>formatSpec</i>	<p>Configures the default location and file name format for the control file autobackup on the specified device type (see <a href="#">Example 2-56</a>).</p> <p>By default, the format is %F for all devices. Any default format string specified with CONFIGURE must include the %F substitution variable. Use of any other substitution variable is an error. Specify CLEAR to return the format to the default %F.</p> <p>If a fast recovery area is enabled, and if the format is the default '%F', then RMAN creates the autobackup in the recovery area in a directory named <code>autobackup</code>. Otherwise, the default autobackup location is an operating system-specific location (<code>*/dbs</code> on UNIX, Linux, and Windows).</p> <p>The string <code># default</code> in the output of the SHOW command indicates when RMAN is using the default format. If you manually configure the disk format to '%F', then RMAN creates the autobackups in the operating system-specific default location even though the recovery area is enabled. To change the format back to its default so that RMAN creates the autobackups in the recovery area, run <code>CONFIGURE AUTOBACKUP FORMAT FOR DEVICE TYPE DISK CLEAR</code>.</p> <p>The <i>formatSpec</i> can specify an Automatic Storage Management disk group. The following example configures a channel for an ASM disk group:</p> <pre>CONFIGURE CONTROLFILE AUTOBACKUP FOR DEVICE TYPE DISK TO '+dgroup1';</pre> <p><b>See Also:</b> <a href="#">formatSpec</a> for the semantics of the %F substitution variable</p>

### *deviceConf*

This subclause creates persistent configurations relating to channels and devices.

#### Names for Configured Channels

RMAN determines the names for configured channels. RMAN uses the following convention: `ORA_devicetype_n`, where *devicetype* refers to the user device type (such as `DISK` or `sbt_tape`) and *n* refers to the channel number. Channel names beginning with the `ORA_` prefix are reserved by RMAN for its own use. You cannot manually allocate a channel with a name that begins with `ORA_`.



#### Note:

The `sbt` and `sbt_tape` device types are synonymous, but RMAN output always displays `sbt_tape` whether the input is `sbt` or `sbt_tape`.

RMAN names the first `DISK` channel `ORA_DISK_1`, the second `ORA_DISK_2`, and so on. RMAN names the first `sbt` channel `ORA_SBT_TAPE_1`, the second `ORA_SBT_TAPE_2`, and so on. When you parallelize channels, RMAN always allocates channels in numeric order, starting with 1 and ending with the parallelism setting (`CONFIGURE DEVICE TYPE ... PARALLELISM n`).

To run `BACKUP` or jobs on specific configured channels, use the system-generated channel names. If you specify channel numbers in the `CONFIGURE CHANNEL` command

(see the [deviceConf](#) clause), then RMAN uses the same numbers in the system-generated channel names.

Automatic channel allocation also applies to maintenance commands. If RMAN allocates an automatic maintenance channel, then it uses the same naming convention as any other automatically allocated channel.

### Configured Channels in an Oracle RAC Environment

When using RMAN in an Oracle RAC environment, Oracle recommends that you specify a `TARGET` connect string that establishes sessions on various instances in the cluster, depending on their load and availability.

Oracle does not recommend using the `CONNECT` option to configure individual channels to connect to specific Oracle RAC instances, because they make your RMAN script dependent on the particular instances named in the channel configuration. If just one of those instances is unavailable, then your backup script fails to run. Using a load-balancing connect string makes your RMAN scripts both easier to code and more resilient to individual instance failures.

If you decide to use the `CONNECT` option to direct RMAN channels to specific nodes, then Oracle strongly recommends that you not use passwords in your channel configuration. If the password for the user with `SYSBACKUP` privilege for every instance is the same as the password in the `TARGET` connection, you only need to configure your channels with `CONNECT "@nodename"`. RMAN connects to that channel with the user ID and password from the `TARGET` connection.

Syntax Element	Description
[AUXILIARY] CHANNEL [ <i>integer</i> ] DEVICE TYPE <a href="#">deviceSpecifier</a>	<p>Specifies the standard or AUXILIARY channel that you are configuring or clearing, and the device type of the channel.</p> <p><b>Note:</b> Channels allocated with <a href="#">ALLOCATE CHANNEL</a> within a <code>RUN</code> command override configured automatic channels.</p> <p>Either configure a generic channel or specify a channel number, where <i>integer</i> is less than 255. See <a href="#">Example 2-54</a> for an illustration of numbered channels.</p> <p>If AUXILIARY is specified, then this configuration is used only for channels allocated at the auxiliary instance. Specify configuration information for auxiliary channels if they require different parameters from the channels allocated at the target instance. If no auxiliary device configuration is specified, then RMAN configures any auxiliary channels using the target database device configuration.</p> <p>You must specify at least one channel option. For example, you cannot issue a command such as <code>CONFIGURE CHANNEL 2 DEVICE TYPE DISK</code>, but you can issue a command such as <code>CONFIGURE CHANNEL 2 DEVICE TYPE DISK MAXPIECESIZE 2500K</code>.</p> <p>For generic channels of a specified device type, a new command erases previous settings for this device type. Assume that you run these commands:</p> <pre>CONFIGURE CHANNEL DEVICE TYPE sbt MAXPIECESIZE 1G; CONFIGURE CHANNEL DEVICE TYPE sbt FORMAT 'bkup_%U';</pre> <p>The second command erases the <code>MAXPIECESIZE</code> setting of the first command.</p> <p><b>Note:</b> RMAN does not simultaneously allocate automatic channels for multiple device types in the <a href="#">BACKUP</a> command.</p> <p><b>See Also:</b> <i>Oracle Database Backup and Recovery User's Guide</i> to learn how to configure automatic channels specified by channel number</p>

Syntax Element	Description
<a href="#">allocOperandList</a>	<p>Specifies control options for the configured channel.</p> <p>If you configure channels by using the nondefault <code>CONNECT</code> or <code>PARMS</code> options to create backups or copies, then you must either use the same configured channels or manually allocate channels with the same options to restore or cross-check these backups.</p> <p>The <code>FORMAT</code> parameter can specify an Automatic Storage Management disk group. The following example configures a channel for an ASM disk group:</p> <pre>CONFIGURE CHANNEL DEVICE TYPE DISK FORMAT '+dgroup1';</pre> <p><b>See Also:</b> <a href="#">allocOperandList</a></p>
<code>CLEAR</code>	<p>Clears the specified channel. For example, <code>CONFIGURE CHANNEL 1 DEVICE TYPE DISK CLEAR</code> returns only channel 1 to its default, whereas <code>CONFIGURE CHANNEL DEVICE TYPE DISK CLEAR</code> returns the generic disk channel to its default. You cannot specify any other channel options (for example, <code>PARMS</code>) when you specify <code>CLEAR</code>.</p>
<code>DEFAULT DEVICE TYPE TO</code> <a href="#">deviceSpecifier</a>	<p>Specifies the default device type for automatic channels. By default, <code>DISK</code> is the default device type. <code>CLEAR</code> returns the default device type to <code>DISK</code>.</p> <p>By default, the <a href="#">BACKUP</a> command only allocates channels of the default device type. For example, if you configure automatic channels for <code>DISK</code> and <code>sbt</code> and set the default device type to <code>sbt</code>, then <code>RMAN</code> only allocates tape channels when you run the <code>BACKUP DATABASE</code> command. You can override this behavior either by manually allocating channels in a <code>RUN</code> command, or by specifying <code>DEVICE TYPE</code> on the <code>BACKUP</code> command itself (see <a href="#">Example 2-52</a>).</p> <p>The <a href="#">RESTORE</a> command allocates automatic channels of all configured device types, regardless of the default device type. The <code>RESTORE</code> command obeys the <code>PARALLELISM</code> setting for each configured device type.</p>
<code>DEVICE TYPE</code> <a href="#">deviceSpecifier</a>	<p>Specifies the device type (disk or <code>sbt</code>) to which to apply the settings specified in this <code>CONFIGURE</code> command. The <code>CLEAR</code> option resets backup type and parallelism settings for this device to their defaults.</p> <p>If you run the <code>CONFIGURE DEVICE TYPE</code> command to configure default settings for a device type and do not run <code>CONFIGURE CHANNEL</code> for this device type, then <code>RMAN</code> allocates all channels without other channel control options. Assume that you configure the <code>sbt</code> device and run a backup as follows:</p> <pre>CONFIGURE DEVICE TYPE sbt PARALLELISM 1; BACKUP DEVICE TYPE sbt DATABASE;</pre> <p>In effect, <code>RMAN</code> does the following when executing this backup:</p> <pre>RUN {   ALLOCATE CHANNEL ORA_SBT_TAPE_1 DEVICE TYPE sbt;   BACKUP DATABASE; }</pre>

Syntax Element	Description
<pre>BACKUP TYPE TO [[COMPRESSED] BACKUPSET   COPY]</pre>	<p>Configures the default backup type for disk or tape backups. For SBT devices the COPY option is not supported. The default for disk is BACKUPSET.</p> <p>If BACKUP TYPE is set to BACKUPSET, then the BACKUP command always produces backup sets regardless of which media the backup is created on. With the COMPRESSED option, the backup sets produced use binary compression.</p> <p>The default location for disk backups is the fast recovery area, if one is configured; otherwise, RMAN stores backups in a platform-specific location. The default format for backup file names is %U.</p>
<pre>PARALLELISM integer</pre>	<p>Configures the number of automatic channels of the specified device type allocated for RMAN jobs. By default, PARALLELISM is set to 1.</p> <p><b>Note:</b> The CONFIGURE ... PARALLELISM parameter specifies channel parallelism, that is, the number of channels that RMAN allocates during backup and restore operations. The RECOVERY_PARALLELISM initialization parameter specifies the number of processes used in instance recovery.</p> <p>Suppose you set PARALLELISM for disk backups to 2 (see Example 2-53). If you set the default device type as disk, then RMAN allocates two disk channels when you run BACKUP DATABASE at the RMAN prompt. RMAN always allocates the number of channels set by PARALLELISM, although it may use only a subset of these channels.</p> <p><b>Note:</b> If you configure <i>n</i> manually numbered channels, then the PARALLELISM setting can be greater than or less than <i>n</i>. For example, you can manually number 10 automatic channels and configure PARALLELISM to 2 or 12.</p> <p>To change the parallelism for a device type to <i>n</i>, run a new CONFIGURE DEVICE TYPE ... PARALLELISM <i>n</i> command. For example, you can change configure PARALLELISM to 3 for sbt and then change it to 2 as follows:</p> <pre>CONFIGURE DEVICE TYPE sbt PARALLELISM 3; CONFIGURE DEVICE TYPE sbt PARALLELISM 2;</pre>
<pre>SPARSE [ON OFF]</pre>	<p>Configures the device type of the database as sparse or non-sparse before performing backup and recovery on sparse datafiles. This setting can only be used if the COMPATIBLE initialization parameter for the database is set to 12.2 or higher.</p> <p>If the SPARSE setting is set to ON, then the BACKUP command creates sparse backups and the RESTORE command performs restore operations from sparse backups. If the SPARSE setting for the device is set to OFF, then RMAN continues to perform database backup and restore operations as before.</p> <p>If COMPATIBLE is set to 12.2 or higher for the database, then ON is the default setting. This setting overrides the default sparseness mode of the database.</p> <p>See <i>Oracle Database Backup and Recovery User's Guide</i> for more information on sparse databases</p>

## Examples

### Example 2-51 Configuring Device and Backup Options

This example configures channels of device type DISK and sbt and sets the default device type as sbt. The example also enables backup optimization and configures a recovery windows of two weeks.

```
CONFIGURE CHANNEL DEVICE TYPE DISK FORMAT '/disk1/backups/%U';
CONFIGURE CHANNEL DEVICE TYPE sbt PARMS 'ENV=(OB_DEVICE_1=tape1)';
CONFIGURE DEFAULT DEVICE TYPE TO sbt;
```

```
CONFIGURE BACKUP OPTIMIZATION ON;
CONFIGURE RETENTION POLICY TO RECOVERY WINDOW OF 14 DAYS;
```

### Example 2-52 Overriding the Default Device Type

This example configures duplexing to 2 for DISK backups of data files and control files (control file autobackups on disk are a special case and are never duplexed), then configures sbt as the default device.

```
CONFIGURE DATAFILE BACKUP COPIES FOR DEVICE TYPE DISK TO 2;
CONFIGURE CHANNEL DEVICE TYPE sbt PARMS 'ENV=(OB_DEVICE_1=tape1)';
CONFIGURE DEFAULT DEVICE TYPE TO sbt;
```

The first BACKUP command backs up the archived redo log files on the default sbt channel. The second BACKUP command backs up the database to disk locations. Because duplexing is enabled for disk backups, two copies of each output backup set are created.

```
BACKUP ARCHIVELOG ALL;
BACKUP DEVICE TYPE DISK
  DATABASE
  FORMAT '/disk1/db_backup_%U','/disk2/db_backup_%U';
```

### Example 2-53 Configuring Automatic Channels Across File Systems

This example configures automatic disk channels across two file systems:

```
CONFIGURE DEVICE TYPE DISK PARALLELISM 2;
CONFIGURE CHANNEL 1 DEVICE TYPE DISK FORMAT '/disk1/%U';
CONFIGURE CHANNEL 2 DEVICE TYPE DISK FORMAT '/disk2/%U';
```

Because PARALLELISM is set to 2, the following command divides the output data between two file systems:

```
BACKUP DEVICE TYPE DISK
  DATABASE PLUS ARCHIVELOG;
```

The following LIST command shows how the data file backup was parallelized:

```
RMAN> LIST BACKUPSET 2031, 2032;
```

```
List of Backup Sets
```

```
=====
```

BS Key	Type	LV	Size	Device	Type	Elapsed Time	Completion Time		
2031	Full		401.99M	DISK		00:00:57	19-JAN-13		
				BP Key:	2038	Status: AVAILABLE	Compressed: NO	Tag: TAG20130119T100532	
				Piece Name:	/disk1/24i7ssnc_1_1				
				List of Datafiles in backup set 2031					
				File	LV	Type	Ckp SCN	Ckp Time	Name
				-----					-----
				1	Full	973497	19-JAN-13	/disk3/oracle/dbs/t_db1.f	
				5	Full	973497	19-JAN-13	/disk3/oracle/dbs/tbs_112.f	
2032	Full		133.29M	DISK		00:00:57	19-JAN-13		
				BP Key:	2039	Status: AVAILABLE	Compressed: NO	Tag: TAG20130119T100532	
				Piece Name:	/disk2/25i7ssnc_1_1				
				List of Datafiles in backup set 2032					

File	LV	Type	Ckp SCN	Ckp Time	Name
2		Full	973501	19-JAN-13	/disk3/oracle/dbs/t_ax1.f
3		Full	973501	19-JAN-13	/disk3/oracle/dbs/t_undol.f
4		Full	973501	19-JAN-13	/disk3/oracle/dbs/tbs_111.f

### Example 2-54 Configuring Automatic Channels in an Oracle Real Application Clusters (Oracle RAC) Configuration

This example assumes an Oracle RAC database with two nodes. Oracle Secure Backup is the media manager. Tape drive `tape1` is directly attached to `node1`, while tape drive `tape2` is directly attached to `node2`. The example configures an automatic SBT channel for each cluster node.

This example illustrates channel connections to Oracle RAC instances `node1` and `node2`. For both channel connections, RMAN uses the same user name and password that were entered for the target database connection.

```
CONFIGURE DEVICE TYPE sbt PARALLELISM 2;
CONFIGURE DEFAULT DEVICE TYPE TO sbt;
CONFIGURE CHANNEL 1 DEVICE TYPE sbt CONNECT '@node1'
  PARMS 'ENV=(OB_DEVICE=tape1)';
CONFIGURE CHANNEL 2 DEVICE TYPE sbt CONNECT '@node2'
  PARMS 'ENV=(OB_DEVICE=tape2)';
```

### Example 2-55 Configuring Auxiliary File Names

This example uses `CONFIGURE AUXNAME` to specify new file names for the data files. The `DUPLICATE` command duplicates a database to a remote host with a different directory structure.

```
# set auxiliary names for the data files
CONFIGURE AUXNAME FOR DATAFILE 1 TO '/oracle/auxfiles/aux_1.f';
CONFIGURE AUXNAME FOR DATAFILE 2 TO '/oracle/auxfiles/aux_2.f';
CONFIGURE AUXNAME FOR DATAFILE 3 TO '/oracle/auxfiles/aux_3.f';
CONFIGURE AUXNAME FOR DATAFILE 4 TO '/oracle/auxfiles/aux_4.f';

RUN
{
  ALLOCATE AUXILIARY CHANNEL dupdb1 TYPE DISK;
  DUPLICATE TARGET DATABASE TO dupdb
  LOGFILE
    GROUP 1 ('?/dbs/dupdb_log_1_1.f',
             '?/dbs/dupdb_log_1_2.f') SIZE 4M,
    GROUP 2 ('?/dbs/dupdb_log_2_1.f',
             '?/dbs/dupdb_log_2_2.f') SIZE 4M REUSE;
}
# Unspecify the auxiliary names for the data files so that they are not
# overwritten by mistake:
CONFIGURE AUXNAME FOR DATAFILE 1 CLEAR;
CONFIGURE AUXNAME FOR DATAFILE 2 CLEAR;
CONFIGURE AUXNAME FOR DATAFILE 3 CLEAR;
CONFIGURE AUXNAME FOR DATAFILE 4 CLEAR;
```

### Example 2-56 Specifying the Default Format for Control File Autobackup

The following example enables the autobackup feature and configures the default autobackup format for the `DISK` and `sbt` devices:



```
CONFIGURE CONTROLFILE AUTOBACKUP ON;
CONFIGURE CONTROLFILE AUTOBACKUP FORMAT FOR DEVICE TYPE DISK TO '/disk2/%F';
CONFIGURE CONTROLFILE AUTOBACKUP FORMAT FOR DEVICE TYPE sbt TO 'cf_auto_%F';
```

### Example 2-57 Creating Configurations for Standby Databases

Assume that primary database `prod` is associated with two standby databases with the `DB_UNIQUE_NAME` names `dgprod3` and `dgprod4`. Assume that you start RMAN and connect to `prod` as `TARGET` and connect to a recovery catalog. The following commands configure the default device type for databases `dgprod3` and `dgprod4`.

```
CONFIGURE DEFAULT DEVICE TYPE TO sbt
  FOR DB_UNIQUE_NAME dgprod3;
CONFIGURE DEVICE TYPE sbt PARALLELISM 2
  FOR DB_UNIQUE_NAME dgprod3;
CONFIGURE DEFAULT DEVICE TYPE TO DISK
  FOR DB_UNIQUE_NAME dgprod4;
```

The control files of the two standby databases are updated with the configuration only after the reverse resynchronization from the recovery catalog to the control file, which occurs the first time that the user connects to `dgprod3` and `dgprod4`.

The following `SHOW` command displays the persistent device type configurations for the database whose unique name is `dgprod3`:

```
RMAN> SHOW DEVICE TYPE FOR DB_UNIQUE_NAME dgprod3;
RMAN configuration parameters for database with db_unique_name DGPROD3 are:

CONFIGURE DEVICE TYPE 'SBT_TAPE' PARALLELISM 2 BACKUP TYPE TO BACKUPSET;
CONFIGURE DEVICE TYPE DISK PARALLELISM 1 BACKUP TYPE TO BACKUPSET; # default
```

The following `SHOW` command displays the persistent configurations for all databases known to the recovery catalog whose `DBID` is 3257174182 (the value specified by the preceding `SET DBID` command):

```
SHOW ALL FOR DB_UNIQUE_NAME ALL;
```

### Example 2-58 Optimizing Backups

This scenario illustrates the backup optimization behavior described in [Table 2-3](#). Assume that backup optimization is disabled. At 9 a.m., you back up three copies of all existing archived redo log files to tape. The `BACKUP_TAPE_IO_SLAVES` initialization parameter must be `true` when duplexing backups to tape.

```
BACKUP DEVICE TYPE sbt COPIES 3 ARCHIVELOG ALL;
```

At 11 a.m., you enable backup optimization:

```
CONFIGURE BACKUP OPTIMIZATION ON;
```

At noon, you run the following archived redo log backup:

```
BACKUP DEVICE TYPE sbt COPIES 2 ARCHIVELOG ALL;
```

```
Starting backup at 19-JAN-13
current log archived
using channel ORA_SBT_TAPE_1
skipping archived log file /d1/db1r_605ab325_1_34_612112605.arc; already backed up 3
time(s)
skipping archived log file /d1/db1r_605ab325_1_35_612112605.arc; already backed up 3
time(s)
skipping archived log file /d1/db1r_605ab325_1_36_612112605.arc; already backed up 3
```

```

time(s)
skipping archived log file /d1/db1r_605ab325_1_37_612112605.arc; already backed up 3 time(s)
skipping archived log file /d1/db1r_605ab325_1_38_612112605.arc; already backed up 3 time(s)
skipping archived log file /d1/db1r_605ab325_1_39_612112605.arc; already backed up 3 time(s)
channel ORA_SBT_TAPE_1: starting archived log backup set
channel ORA_SBT_TAPE_1: specifying archived log(s) in backup set
input archived log thread=1 sequence=40 RECID=170 STAMP=612270506
channel ORA_SBT_TAPE_1: starting piece 1 at 19-JAN-13
channel ORA_SBT_TAPE_1: finished piece 1 at 19-JAN-13 with 2 copies and tag TAG20130119T110827
piece handle=2hi7t0db_1_1 comment=API Version 2.0,MMS Version 10.1.0.0
piece handle=2hi7t0db_1_2 comment=API Version 2.0,MMS Version 10.1.0.0

```

In this case, the `BACKUP ... COPIES` setting overrides the `CONFIGURE ... COPIES` setting, so RMAN sets  $n=2$ . RMAN skips the backup of a log only if at least two copies of the log exist on the `sbt` device. Because three copies of each log exist on `sbt` of all the logs generated on or before 9 a.m., RMAN skips the backups of these logs. However, RMAN backs up two copies of all logs generated after 9 a.m. because these logs have not yet been backed up to tape.

### Example 2-59 Configuring a Default Compression Algorithm

This example assumes that you have a license for the Advanced Compression Option (ACO) of the database.

If you want to make the `MEDIUM` compression algorithm the default compression algorithm for all compressed backups, issue the following:

```
CONFIGURE COMPRESSION ALGORITHM 'MEDIUM';
```

From this point on, you can use the `MEDIUM` compression algorithm by issuing the following command:

```
BACKUP AS COMPRESSED BACKUPSET DATABASE;
```

### Example 2-60 Configuring Sparse Backups

This example creates a persistent configuration that, by default, creates sparse backups to disk and in the backup set format.

```
CONFIGURE DEVICE TYPE DISK BACKUP TYPE TO BACKUPSET SPARSE ON;
```

## 2.10 CONNECT

### Purpose

Use the `CONNECT` command to establish a connection between RMAN and a target, auxiliary, or recovery catalog database.

### Prerequisites

RMAN connections to a database are specified and authenticated in the same way as SQL\*Plus connections to a database. The only difference is that RMAN connections to a target or auxiliary database require the `SYSPRIVILEGE` or `SYSDBA` privilege.

To connect to the CDB, you connect to the root as a common user with the `SYSDBA` or `SYSPRIVILEGE` privilege.

To connect to a PDB, you can connect either as a common user or a local user. The user creating the connection must have the privileges described in "[connectStringSpec](#)".

 **See Also:**

- *Oracle Database Administrator's Guide* to learn about database connection options when using SQL\*Plus
- *Oracle Database Backup and Recovery User's Guide* to learn about using the `SYSBACKUP` administrative privilege

 **Caution:**

Good security practice requires that passwords are not entered in plain text on the command line. Enter passwords in RMAN only when requested by an RMAN prompt. See *Oracle Database Security Guide* to learn about password protection.

 **See Also:**

[RMAN](#) for command-line connection options

You can only run the `CONNECT TARGET`, `CONNECT CATALOG`, and `CONNECT AUXILIARY` commands at the RMAN prompt and only if RMAN is not already connected to the databases specified by these commands. To connect to a different target, catalog, or auxiliary database you must start a new RMAN session.

### Usage Notes

To perform operations on the whole CDB, the root, or multiple PDBs, you connect as `TARGET` to the root and as a common user with the `SYSDBA` or `SYSBACKUP` privilege. To perform operations on a single PDB, you can connect as `TARGET` either to the root or to the PDB and as a local user or common user with the `SYSDBA` or `SYSBACKUP` privilege.

An RMAN session runs in `NOCATALOG` mode by default if all of the following conditions are met:

- You did not specify `CATALOG` or `NOCATALOG` when you started [RMAN](#).
- You have not yet run `CONNECT CATALOG` in an RMAN session.
- You run a command such as `BACKUP` that requires an RMAN repository connection (as shown in [Example 2-62](#)).

 **See Also:**

- *Oracle Database Concepts* for information about multitenant architecture concepts
- *Oracle Database Administrator's Guide* for information about managing a multitenant environment

 **See Also:**

*Oracle Database Backup and Recovery User's Guide* for additional information about connecting to CDBs and PDBs

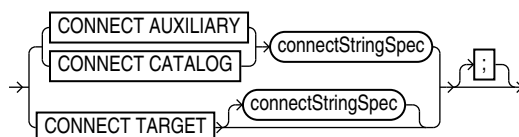
**Syntax****connect::=****(connectStringSpec::=)****Semantics**

Syntax Element	Description
CONNECT AUXILIARY	Establishes a connection between RMAN and an auxiliary database instance. Auxiliary instances are used with the <a href="#">TRANSPORT TABLESPACE</a> and <a href="#">DUPLICATE</a> commands, and during RMAN TSPITR.
CONNECT CATALOG	Establishes a connection between RMAN and a recovery catalog database. If the recovery catalog is a virtual private catalog (see <a href="#">CREATE CATALOG</a> ), then the RMAN client connecting to this catalog must be at patch level 10.1.0.6 or 10.2.0.3. Oracle9i RMAN clients cannot connect to a virtual private catalog. This version restriction does not affect RMAN client connections to an Oracle Database 11g base recovery catalog, even if it has some virtual private catalog users. RMAN issues an RMAN-06445 error if you attempt to use the <code>CONNECT CATALOG</code> command in an RMAN session when RMAN is in the default <code>NOCATALOG</code> mode (see " <a href="#">Usage Notes</a> "). <b>Note:</b> You must use RMAN with a recovery catalog in a Data Guard environment.

Syntax Element	Description
CONNECT TARGET	Establishes a connection between RMAN and a target database. <b>Note:</b> RMAN can connect to physical standby databases as TARGET in a Data Guard environment. If you run CONNECT TARGET for a database that has a DB_UNIQUE_NAME that is unknown to the recovery catalog, but the DBID identifies a registered database, then RMAN automatically and implicitly registers the database in the recovery catalog.
<a href="#">connectStringSpec</a>	Specifies the connection information for the database.

## Examples

### Example 2-61 Connecting to a Target Database Without a Recovery Catalog

This example starts RMAN in NOCATALOG mode and then connects to the target database with an Oracle Net service name prod1. sbu is a user who is granted the SYSBACKUP privilege.

```
% rman NOCATALOG
RMAN> CONNECT TARGET "sbu@prod1 AS SYSBACKUP";

target database Password: password
connected to target database: PROD1 (DBID=39525561)
```

### Example 2-62 Connecting to a Target Database in the Default NOCATALOG Mode

This example starts RMAN without specifying either CATALOG or NOCATALOG and then uses operating system authentication to connect to a target database with operating system authentication. Because no CONNECT CATALOG command has been run, RMAN defaults to NOCATALOG mode when you run the BACKUP command.

```
% rman
RMAN> CONNECT TARGET /
RMAN> BACKUP DATABASE;
```

At this point in the RMAN session, you cannot run CONNECT CATALOG because the session has defaulted to NOCATALOG mode. An attempt to connect to the catalog in this session receives an error:

```
RMAN> CONNECT CATALOG rco@catdb

RMAN-00571: =====
RMAN-00569: ===== ERROR MESSAGE STACK FOLLOWS =====
RMAN-00571: =====
RMAN-06445: cannot connect to recovery catalog after NOCATALOG has been used
```

### Example 2-63 Connecting to Target, Recovery Catalog, and Auxiliary Databases

This example connects to a target database with operating system authentication and connects to the recovery catalog and auxiliary databases with password files. sbu is a user who is granted the SYSBACKUP privilege. RMAN prompts for the password.

```
% rman
RMAN> CONNECT TARGET;

connected to target database: PROD (DBID=39525561)
```

```
RMAN> CONNECT CATALOG rco@catdb;

recovery catalog database Password: password
connected to recovery catalog database

RMAN> CONNECT AUXILIARY "sbu@dupdb AS SYSBACKUP";

auxiliary database Password: password
connected to auxiliary database: DUPDB (not mounted)
```

### Example 2-64 Connecting to the Root Using Operating System Authentication

This example connects to the root in a CDB using operating system authentication. By default, the connection is established using `SYSDBA` privilege.

```
%rman
RMAN> CONNECT TARGET /
```

### Example 2-65 Connecting to a PDB as a Local User

This example connects to the PDB `hr_pdb` as the local user `sbu_pdb` who is granted the `SYSBACKUP` privilege on the `hr_pdb` PDB. `hrpdb` is the net service name corresponding to the PDB `hr_pdb`.

```
%rman
RMAN> CONNECT TARGET "sbu_pdb@hrpdb AS SYSBACKUP";
```

## 2.11 CONVERT

### Purpose

Use the `CONVERT` command to convert a tablespace, data file, or database to the format of a destination platform in preparation for transport across different platforms.

The `CONVERT DATAFILE` or `CONVERT TABLESPACE` command is required in the following scenarios:

- Transporting data files between platforms for which the value in `V$TRANSPORTABLE_PLATFORM.ENDIAN_FORMAT` differs.
- Transporting tablespaces with undo segments (typically `SYSTEM` and `UNDO` tablespaces, but also tablespaces using rollback segments) between platforms, regardless of whether the `ENDIAN_FORMAT` is the same or different. Typically, the `SYSTEM` and `UNDO` tablespaces are converted only when converting the entire database.
- Performing any required conversion on other platform-specific data files, such as when converting to or from the HP Tru64 operating system.

One use of `CONVERT` is to transport a tablespace into a database stored in Oracle Automatic Storage Management (Oracle ASM). Native operating system commands such as Linux `cp` and Microsoft Windows `COPY` cannot read from or write to Oracle ASM disk groups.

Note that `CONVERT` cannot be used to convert a database from one Oracle Database version to another.

 **See Also:**

*Oracle Database Backup and Recovery User's Guide* for a complete discussion of the use of `CONVERT DATAFILE`, `CONVERT TABLESPACE`, and `CONVERT DATABASE`

### Prerequisites

The source and destination platforms must be supported by the `CONVERT` command. Query `V$TRANSPORTABLE_PLATFORM` to determine the supported platforms. Cross-platform tablespace transport is only supported when both the source and destination platforms are contained in this view.

Both source and destination databases must be running with initialization parameter `COMPATIBLE` set to 10.0.0 or higher. Note the following compatibility prerequisites:

- If `COMPATIBLE` is less than 11.0.0, then read-only tablespaces or existing transported tablespaces must have been made read/write at least once before they can be transported to a different platform. You can open a tablespace read/write and then immediately make it read-only again.
- If `COMPATIBLE` is 11.0.0 or higher, then the preceding read/write tablespace restriction does not apply. However, any *existing* transported tablespaces must have been made read/write with `COMPATIBLE` set to 10.0 before they were transported.

### CONVERT TABLESPACE Prerequisites

You can only use `CONVERT TABLESPACE` when connected as `TARGET` to the *source* database and converting tablespaces on the source platform.

The source database must be mounted or open. The tablespaces to be converted must be read-only at the time of the conversion. The state of the destination database is irrelevant when converting tablespaces on the source database.

### CONVERT DATAFILE Prerequisites

You can only use `CONVERT DATAFILE` when connected as `TARGET` to the *destination* database and converting data file copies on the destination platform.

If you run a `CONVERT DATAFILE` script generated by `CONVERT DATABASE ON DESTINATION`, then the destination database instance must be started with the `NOMOUNT` option. If you are *not* running a `CONVERT DATAFILE` script generated by `CONVERT DATABASE ON DESTINATION`, then the destination database can be started, mounted, or open.

The state of the source database is irrelevant when converting data file copies on the destination database. However, if you run a `CONVERT DATAFILE` script as part of a database conversion on the destination database, and if the script is directly accessing the data files on the source database (for example, through an NFS mount), then the source database must be open read-only.

When converting a tablespace on the destination host, you must use `CONVERT DATAFILE` rather than `CONVERT TABLESPACE` because the target database cannot associate the data files with tablespaces during the conversion. After you have

converted the data files required for a tablespace, you can transport them into the destination database.

### CONVERT DATABASE Prerequisites

You can only use `CONVERT DATABASE` when connected as `TARGET` to the *source* database, which must be opened read-only. The state of the destination database is irrelevant when executing `CONVERT DATABASE`, even if you run `CONVERT DATABASE ON DESTINATION`.

Because `CONVERT DATABASE` uses the same mechanism as `CONVERT TABLESPACE` and `CONVERT DATAFILE` to convert the data files, the usage notes and restrictions for tablespaces and data files also apply.

The primary additional prerequisite for `CONVERT DATABASE` is that the source and target platforms must share the same endian format. For example, you can transport a database from Microsoft Windows to Linux for x86 (both little-endian), or from HP-UX to AIX (both big-endian), but not from Solaris to Linux x86. You can create a new database on a target platform manually, however, and transport individual tablespaces from the source database with `CONVERT TABLESPACE` or `CONVERT DATAFILE`.

Even if the endian formats for the source and destination platform are the same, the data files for a transportable database must undergo a conversion on either the source or destination host. Unlike transporting tablespaces across platforms, where conversion is not necessary if the endian formats are the same, transporting an entire database requires that certain types of blocks, such as blocks in undo segments, be converted to ensure compatibility with the destination platform.

### Usage Notes

Input files are not altered by `CONVERT` because the conversion is not performed in place. Instead, `RMAN` writes converted files to a specified output destination.

### Data Type Restrictions

`CONVERT` does not perform endian conversions of data stored in the following data types:

- RAW
- LONG RAW
- BLOB
- ANYTYPE/ANYDATA/ANYDATASET
- User-defined types or Oracle abstract types (such as the `ORDImage` media type) that contain attributes of any of the above data types

#### Note:

Although the file locator within the `BFILE` data type is converted, the external file to which the `BFILE` points is not converted.

To transport objects between databases that are built on underlying types that store data in a platform-specific format, use the Data Pump Import and Export utilities.

Before Oracle Database 10g, CLOBs in a variable-width character set such as `UTF8` were stored in an endian-dependent fixed width format. The `CONVERT` command does not perform



conversions on these CLOBs. Instead, RMAN captures the endian format of each LOB column and propagates it to the target database. Subsequent reads of this data by the SQL layer interpret the data correctly based on either endian format and write it out in an endian-independent way if the tablespace is writeable. CLOBs created in Oracle Database 10g and later releases are stored in character set AL16UTF16, which is platform-independent.



**See Also:**

*Oracle Database Administrator's Guide* to learn how to transport tablespaces

**Syntax**

**convert::=**

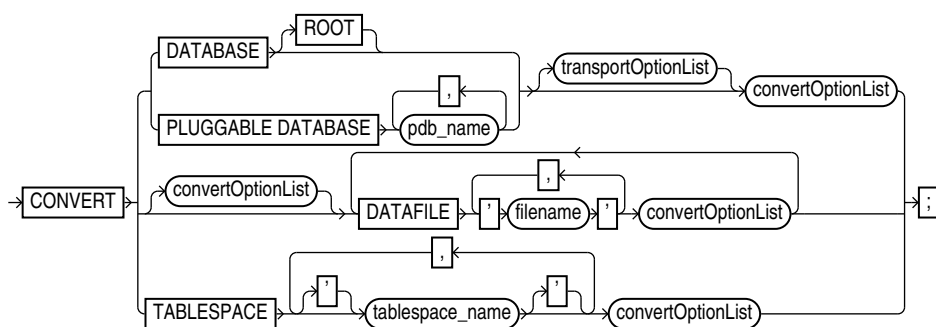

([transportOptionList::=](#), [convertOptionList::=](#))

**transportOptionList::=**

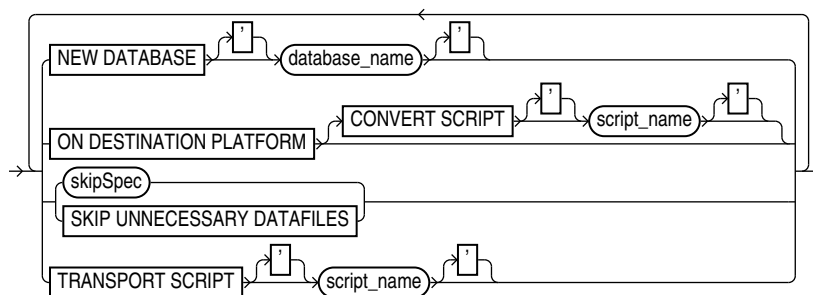

([skipSpec::=](#))

**skipSpec::=**

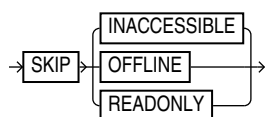

***convertOptionList::=***

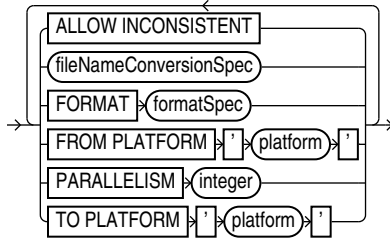

([fileNameConversionSpec::=](#), [formatSpec::=](#))

***formatSpec::=***

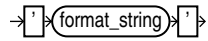

### Semantics

#### ***convert***

This clause specifies the objects to be converted: data files, tablespaces, or database.

Syntax Element	Description
DATABASE	<p>Converts all the data files of a database to the format of the destination platform and ensures the creation of other required database files.</p> <p>In a multitenant container database (CDB), converts all the data files in the CDB. You connect to the root to convert the whole CDB.</p> <p><b>Note:</b> Converting a PDB by connecting to the PDB and then using the <code>CONVERT DATABASE</code> command is not supported.</p> <p>You use <code>CONVERT DATABASE</code> to transport an entire database from a source platform to a destination platform. The source and destination platforms must have the same endian format.</p> <p>Depending on the situation, you can use <code>CONVERT DATABASE</code> on either the source or destination platform (see <a href="#">Example 2-69</a>). The following parts of the database are not transported directly:</p> <ul style="list-style-type: none"> <li>Redo logs and control files from the source database are not transported. RMAN creates new control files and redo logs for the target database during the transport and performs an <code>OPEN RESETLOGS</code> after the new database is created. The control file for the converted database does not contain the RMAN repository from the source database. Backups from the source database are not usable with the converted database.</li> <li>BFILEs are not transported. The <code>CONVERT DATABASE</code> output provides a list of objects that use the BFILE data type, but you must copy the BFILEs manually and fix their locations on the target platform.</li> <li>Data files for locally managed temporary tablespaces are not transported. The temporary tablespaces are re-created at the target platform by running the transport script.</li> <li>External tables and directories are not transported. The <code>CONVERT DATABASE</code> output shows a list of affected objects, but you must redefine these objects on the target platform. See <i>Oracle Database Administrator's Guide</i> for more information on managing external tables and directories.</li> <li>Password files are not transported. If a password file was used with the source database, then the output of <code>CONVERT DATABASE</code> includes a list of all user names and their associated privileges. Create a new password file on the target database with this information. See <i>Oracle Database Administrator's Guide</i> for more information on managing password files.</li> </ul> <p>When using <code>CONVERT DATABASE</code>, RMAN detects the following problems and does not proceed until they are fixed:</p> <ul style="list-style-type: none"> <li>The database has active or in-doubt transactions.</li> <li>The database has save undo segments.</li> <li>The database <code>COMPATIBILITY</code> setting is below 10.</li> <li>Some tablespaces have not been open read/write when the database <code>COMPATIBILITY</code> setting is 10 or higher.</li> </ul>
DATABASE ROOT	<p>In a CDB, converts the data files of the root to the format of the destination platform and ensures the creation of other required database files. Connect to the root and convert the data files.</p> <p>See the previous description of the <code>DATABASE</code> parameter for general information about converting databases.</p>
<a href="#">transportOptionList</a>	<p>Specifies options that control the transport.</p> <p><b>See Also:</b> <a href="#">transportOptionList</a></p>
PLUGGABLE DATABASE <i>pdb_name</i>	<p>This clause is not supported for converting one or more PDBs.</p> <p>You can use the <code>BACKUP</code> command with the <code>FOR TRANSPORT</code> or <code>TO PLATFORM</code> clause to create backup sets that can be used to transport one or more PDBs.</p>

Syntax Element	Description
<a href="#">[convertOptionList]</a> DATAFILE 'filename' <a href="#">convertOptionList</a>	<p>Specifies the name of a data file to be transported into a destination database (see <a href="#">Example 2-67</a>). To transport a data file in a PDB, connect to the PDB.</p> <p><b>Note:</b> You cannot convert a tablespace that contains undo segments when connected as <code>TARGET</code> to a PDB.</p> <p>The <code>CONVERT DATAFILE</code> command is only one part of a multiple-step procedure for transporting data files across platforms. You can transport data files using your live data files with the procedure described in <i>Oracle Database Administrator's Guide</i> or from backups using the procedure described in <i>Oracle Database Backup and Recovery User's Guide</i>. Refer to that document before attempting to transport a tablespace across platforms.</p> <p>Use <code>FROM PLATFORM</code> in <a href="#">convertOptionList</a> to identify the source platform of the data files to be converted. If you do not specify <code>FROM PLATFORM</code>, then the value defaults to the platform of the destination database, that is, the database to which RMAN is connected as <code>TARGET</code>. The destination platform is, implicitly, the platform of the destination host.</p> <p>You can use <code>CONVERT DATAFILE</code> without <code>FROM PLATFORM</code> or <code>TO PLATFORM</code> to move data files into and out of ASM (see <a href="#">Example 2-68</a>). In this case, <code>CONVERT DATAFILE</code> creates data files copies that do not belong to the target database. Thus, a <a href="#">LIST DATAFILECOPY</a> command does not display them. The following query shows all converted data files that do not belong to the database:</p> <pre>SELECT NAME FROM   V\$DATAFILE_COPY WHERE  CONVERTED_FILE='YES';</pre> <p>The <code>CONVERT DATAFILE</code> syntax supports multiple format names, so that each data file can have a separate format. The <code>DATAFILE</code> syntax supports <a href="#">convertOptionList</a> both immediately following the <code>CONVERT</code> keyword and after each <code>DATAFILE 'filename'</code> clause. However, RMAN generates an error in the following situations:</p> <ul style="list-style-type: none"> <li>• Any option in <a href="#">convertOptionList</a> except <code>FORMAT</code> is specified more than once</li> <li>• Any option in <a href="#">convertOptionList</a> except <code>FORMAT</code> is specified in the <code>DATAFILE</code> options list when multiple <code>DATAFILE</code> clauses are specified</li> </ul>

Syntax Element	Description
TABLESPACE <i>tablespace_name</i> <a href="#">convertOptionList</a>	<p>Specifies the name of a tablespace in the source database that you intend to transport into the destination database on a different platform (see <a href="#">Example 2-66</a>).</p> <p>To transport a tablespace in a PDB, you must connect to the PDB.</p> <p>Specify this option to produce data files for the specified tablespaces in the format of a different destination platform. You can then transport the converted files to the destination platform.</p> <p>When connected to the root in a CDB, refers to tablespaces in the root. Refers to a tablespace in a PDB when connected directly to a PDB.</p> <p>You can only use <code>CONVERT TABLESPACE</code> when connected as <code>TARGET</code> to the source database and converting on the source platform. The tablespaces to be converted must be read-only at the time of the conversion. You use <code>CONVERT TABLESPACE</code> when the data files that you intend to convert are known to the database.</p> <p>Use <code>TO PLATFORM</code> to identify the destination platform of the tablespaces to be converted. If you do not specify <code>TO PLATFORM</code>, then the value defaults to the platform of the database to which RMAN is connected as <code>TARGET</code>. The source platform is, implicitly, the platform of the source host.</p> <p>The <code>CONVERT TABLESPACE</code> command is only one part of a multiple-step process for transporting tablespaces across platforms. You can transport tablespaces using your live data files with the procedure described in <i>Oracle Database Administrator's Guide</i> or from backups using the procedure described in <i>Oracle Database Backup and Recovery User's Guide</i>. Refer to that document before attempting to transport a tablespace across platforms.</p> <p><b>Note:</b> To convert the data files of a tablespace on the source host, use <code>CONVERT TABLESPACE . . . TO</code> and identify the tablespace to be converted and the destination platform. Do not convert individual data files on the source platform with <code>CONVERT DATAFILE</code> because RMAN does not verify that data files belong to a read-only tablespace, which means you might convert active data files.</p> <p><a href="#">convertOptionList</a></p> <p>Specifies options that control the conversion.</p> <p><b>See Also:</b> <a href="#">convertOptionList</a></p>

### *transportOptionList*

This clause specifies options for the data files, tablespaces, or database to be transported.

Syntax Element	Description
NEW DATABASE <i>database_name</i>	<p>Specifies the <code>DB_NAME</code> for the new database produced by the <code>CONVERT DATABASE</code> command.</p>

Syntax Element	Description
ON DESTINATION PLATFORM	<p>Generates a convert script of <code>CONVERT DATAFILE</code> commands (see <code>CONVERT SCRIPT</code> parameter) that you can run on the destination host to create the database.</p> <p><b>Note:</b> When this option is specified, <code>CONVERT</code> generates a script but does not generate converted data file copies.</p> <p>This option is useful for avoiding the overhead of the conversion on the source platform, or in cases in which you do not know the destination platform. For example, you may want to publish a transportable tablespace to be used by recipients with many different target platforms.</p> <p>When you run <code>CONVERT</code> with the <code>ON DESTINATION PLATFORM</code> option, the source database must be open read-only. However, the script generated by <code>CONVERT ON DESTINATION PLATFORM</code> must be run on a database instance that is started <code>NOMOUNT</code>. If the convert script reads data files from the source database during execution of the <code>CONVERT DATAFILE</code> commands, then the source database must not be open read/write during the execution.</p>
<code>CONVERT SCRIPT</code> <i>script_name</i>	<p>Specifies the location of the file to contain the convert script generated by <code>CONVERT DATABASE ... ON TARGET PLATFORM</code>.</p> <p>If not specified, the convert script is not generated.</p>
<a href="#">skipSpec</a>	<p><code>CONVERT DATABASE</code> skips inaccessible, offline, or read-only data files during the conversion process.</p>
SKIP UNNECESSARY DATAFILES	<p>Converts only data files with undo segments. If converting at the destination platform then the generated <code>CONVERT</code> script only includes data files with undo segments. Data files without undo segments do not need to be converted and can be copied directly from the source database to the destination database. If the command is converting from or to hp Tru64, data files with ASSM segment headers must also be converted.</p>
TRANSPORT SCRIPT <i>script_name</i>	<p>Specifies the location of the file to contain the transport script generated by <code>CONVERT DATABASE</code>. If omitted, the transport script is not generated.</p>

### *skipSpec*

This subclause specifies which files are excluded from the conversion.

Syntax Element	Description
SKIP	Excludes data files according to the criteria specified by the following keywords.
INACCESSIBLE	<p>Excludes data files that cannot be read due to I/O errors.</p> <p>A data file is only considered inaccessible if it cannot be read. Some offline data files can still be read because they still exist on disk. Others have been deleted or moved and so cannot be read, making them inaccessible.</p>
OFFLINE	Excludes offline data files.
READONLY	Excludes read-only data files.

### *convertOptionList*

This subclause specifies input and output options for the conversion.

You can use either the `FORMAT` or [fileNameConversionSpec](#) arguments to control the names of the output files generated by the `CONVERT` command. If you do not specify either, then the rules governing the location of the output files equal those governing the output files from a `BACKUP AS COPY` operation. These rules are described in the [backupTypeSpec](#) entry.

Syntax Element	Description
ALLOW INCONSISTENT	<p>Enables you to create an inconsistent backup of tablespaces that are not in read-only mode. Although the backup is created, you cannot plug in these tablespaces directly into the target database.</p> <p><b>Note:</b> You cannot use <code>ALLOW INCONSISTENT</code> for cross-platform database backups.</p>
<code>fileNameConversionSpec</code>	<p>A set of string pairs. Whenever an input file name contains the first half of a pair anywhere in the file name, it is replaced with the second half of the same pair. You can use as many pairs of replacement strings as required. You can use single or double quotation marks.</p> <p><b>See Also:</b> "Duplication with Oracle Managed Files" to learn about restrictions related to ASM and Oracle Managed Files</p>
FORMAT <code>formatSpec</code>	<p>Specifies the name template for the output files. See the <code>BACKUP AS COPY</code> command for the format values that are valid here.</p> <p>If the database to which RMAN is connected as <code>TARGET</code> uses a recovery area, then you must specify the <code>FORMAT</code> clause.</p> <p>You can use <code>CONVERT ... FORMAT</code> without specifying <code>FROM PLATFORM</code> or <code>TO PLATFORM</code>. If you do not specify platforms, then running <code>CONVERT TABLESPACE</code> on the source database generates data file copies that are not cataloged. If you run <code>CONVERT DATAFILE</code> on the destination database, and if the data file copy uses the same endianness, then the command generates another data file copy.</p> <p>As shown in <a href="#">Example 2-68</a>, you can use <code>CONVERT DATAFILE ... FORMAT</code> to convert a data file into ASM format. For very large data files, copying data files between hosts consumes a large amount of space. Consider using NFS or disk sharing. You can create a backup on the source host, mount the disk containing the backups on the destination host, and then convert the data file into ASM.</p>
FROM PLATFORM ' <i>platform</i> '	<p>Specifies the name of the source platform. If not specified, the default is the platform of the database to which RMAN is connected as <code>TARGET</code>.</p> <p>The specified platform must be a platform listed in the <code>PLATFORM_NAME</code> column of <code>V\$TRANSPORTABLE_PLATFORM</code>. You must use the exact name of the source or target platform as a parameter to the <code>CONVERT</code> command. The following statement queries supported Linux platforms:</p> <pre>SELECT PLATFORM_NAME, ENDIAN_FORMAT FROM   V\$TRANSPORTABLE_PLATFORM WHERE  UPPER(PLATFORM_NAME) LIKE 'LINUX%';</pre>
PARALLELISM <i>integer</i>	<p>Specifies the number of channels to be used to perform the operation. If not used, then channels allocated or configured for disk determine the number of channels.</p>
TO PLATFORM ' <i>platform</i> '	<p>Specifies the name of the destination platform. If not specified, the default is the platform of the database to which RMAN is connected as <code>TARGET</code>.</p> <p>The specified platform must be a platform listed in the <code>PLATFORM_NAME</code> column of <code>V\$TRANSPORTABLE_PLATFORM</code>. You must use the exact name of the source or target platform as a parameter to the <code>CONVERT</code> command. The following SQL statement queries supported Linux platforms:</p> <pre>SELECT PLATFORM_NAME, ENDIAN_FORMAT FROM   V\$TRANSPORTABLE_PLATFORM WHERE  UPPER(PLATFORM_NAME) LIKE 'LINUX%';</pre>

## Examples

### Example 2-66 Converting Tablespaces on the Source Platform

Suppose you must convert tablespaces `finance` and `hr` in source database `prodlin` to the platform format of destination database `prodsun`. The `finance` tablespace includes data files `/disk2/orahome/fin/fin01.dbf` and `/disk2/orahome/fin/fin02.dbf`. The `hr` tablespace includes data files `/disk2/orahome/fin/hr01.dbf` and `/disk2/orahome/fin/hr02.dbf`.

The `prodlin` database runs on Linux host `lin01`. You query `V$DATABASE` and discover that platform name is `Linux IA (32-bit)` and uses a little-endian format. The `prodsun` database runs on Solaris host `sun01`. You query `V$TRANSPORTABLE_PLATFORM` and discover that the `PLATFORM_NAME` for the Solaris host is `Solaris[tm] OE (64-bit)`, which uses a big-endian format.

You plan to convert the tablespaces on the source host and store the converted data files in `/tmp/transport_to_solaris/` on host `lin01`. The example assumes that you have set `COMPATIBLE` is to 10.0 or greater on the source database.

On source host `lin01`, you start the RMAN client and run the following commands, where `SBU` is any user with the `SYSBACKUP` privilege:

```
CONNECT TARGET "sbu@prodlin AS SYSBACKUP"

target database Password: password
connected to target database: PRODLIN (DBID=39525561)

ALTER TABLESPACE finance READ ONLY;
ALTER TABLESPACE hr READ ONLY;
CONVERT TABLESPACE finance, hr
  TO PLATFORM 'Solaris[tm] OE (64-bit)'
  FORMAT '/tmp/transport_to_solaris/%U';
```

The result is a set of converted data files in the `/tmp/transport_to_solaris/` directory, with data in the right endian-order for the Solaris 64-bit platform.

From this point, you can follow the rest of the general outline for tablespace transport. Use the Data Pump Export utility to create the file of structural information, move the structural information file and the converted data files from `/tmp/transport_to_solaris/` to the desired directories on the destination host, and plug the tablespace into the new database with the Data Pump Import utility.

### Example 2-67 Converting Data Files on the Destination Platform

This example assumes that you want to convert the `finance` and `hr` tablespaces from database `prodsun` on host `sun01` into a format usable by database `prodlin` on destination host `lin01`. You temporarily store the unconverted data files in directory `/tmp/transport_from_solaris/` on destination host `lin01` and perform the conversion with `CONVERT DATAFILE`. When you transport the data files into the destination database, they are stored in `/disk2/orahome/dbs`.

The example assumes that you have carried out the following steps in preparation for the tablespace transport:

- You used the Data Pump Export utility to create the structural information file (named, in our example, `expdat.dmp`).



- You made the `finance` and `hr` tablespaces read-only on the source database.
- You used an operating system utility to copy `expdat.dmp` and the unconverted data files to be transported to the destination host `lin01` in the `/tmp/transport_from_solaris` directory. The data files are stored as:
  - `/tmp/transport_from_solaris/fin/fin01.dbf`
  - `/tmp/transport_from_solaris/fin/fin02.dbf`
  - `/tmp/transport_from_solaris/hr/hr01.dbf`
  - `/tmp/transport_from_solaris/hr/hr02.dbf`
- You queried the name for the source platform in `V$TRANSPORTABLE_PLATFORM` and discovered that the `PLATFORM_NAME` is `Solaris[tm] OE (64-bit)`.

Note the following considerations when performing the conversion:

- Identify the data files by file name, not by tablespace name. Until the data files are plugged in, the local instance has no way of knowing the intended tablespace names.
- The `FORMAT` argument controls the name and location of the converted data files.
- When converting on the destination host, you must specify the source platform with the `FROM` argument. Otherwise, `RMAN` assumes that the source platform is also the platform of the host performing the conversion.

You start the `RMAN` client and connect to the destination database `prodlin` as `TARGET`. `sbu` is a user who is granted the `SYSBACKUP` privilege. The following `CONVERT` command converts the data files to be transported to the destination host format and deposits the results in `/disk2/orahome/dbs`:

```
CONNECT TARGET "sbu@prodlin AS SYSBACKUP"

target database Password: password
connected to target database: PRODLIN (DBID=39525561)

CONVERT DATAFILE
  '/tmp/transport_from_solaris/fin/fin01.dbf',
  '/tmp/transport_from_solaris/fin/fin02.dbf',
  '/tmp/transport_from_solaris/hr/hr01.dbf',
  '/tmp/transport_from_solaris/hr/hr02.dbf'
DB_FILE_NAME_CONVERT
  '/tmp/transport_from_solaris/fin','/disk2/orahome/dbs/fin',
  '/tmp/transport_from_solaris/hr','/disk2/orahome/dbs/hr'
FROM PLATFORM 'Solaris[tm] OE (64-bit)';
```

The result is that the following data files have been converted to the Linux format:

- `/disk2/orahome/dbs/fin/fin01.dbf`
- `/disk2/orahome/dbs/fin/fin02.dbf`
- `/disk2/orahome/dbs/hr/hr01.dbf`
- `/disk2/orahome/dbs/hr/hr02.dbf`

From this point, follow the rest of the general outline for tablespace transport. Use Data Pump Import to plug the converted tablespaces into the new database, and make the tablespaces read/write if applicable.

**Example 2-68 Copying Data Files to and from ASM with CONVERT DATAFILE**

This example illustrates copying data files into ASM from normal storage. The generated files are not considered data file copies that belong to the target database, so `LIST DATAFILECOPY` does not display them.

Use `CONVERT DATAFILE` without specifying a source or destination platform. Specify ASM disk group `+DATAFILE` for the output location, as shown here:

```
RMAN> CONVERT DATAFILE '/disk1/oracle/dbs/my_tbs_f1.df',
      '/disk1/oracle/dbs/t_ax1.f'
      FORMAT '+DATAFILE';
```

```
Starting conversion at 29-MAY-13
using channel ORA_DISK_1
channel ORA_DISK_1: starting datafile conversion
input filename=/disk1/oracle/dbs/t_ax1.f
converted datafile=+DATAFILE/asmv/datafile/sysaux.280.559534477
channel ORA_DISK_1: datafile conversion complete, elapsed time: 00:00:16
channel ORA_DISK_1: starting datafile conversion
input filename=/disk1/oracle/dbs/my_tbs_f1.df
converted datafile=+DATAFILE/asmv/datafile/my_tbs.281.559534493
channel ORA_DISK_1: datafile conversion complete, elapsed time: 00:00:04
Finished conversion at 29-MAY-13
```

The following example illustrates copying the data files of a tablespace out of ASM storage to directory `/tmp`, with uniquely generated file names.

```
RMAN> CONVERT TABLESPACE tbs_2 FORMAT '/tmp/tbs_2_%U.df';
```

```
Starting conversion at 03-JUN-13
using target database control file instead of recovery catalog
allocated channel: ORA_DISK_1
channel ORA_DISK_1: sid=20 devtype=DISK
channel ORA_DISK_1: starting datafile conversion
input datafile fno=00006 name=+DATAFILE/tbs_21.f
converted datafile=/tmp/tbs_2_data_D-L2_I-2786301554_TS-TBS_2_FNO-6_11gm2fq9.df
channel ORA_DISK_1: datafile conversion complete, elapsed time: 00:00:01
channel ORA_DISK_1: starting datafile conversion
input datafile fno=00007 name=+DATAFILE/tbs_22.f
converted datafile=/tmp/tbs_2_data_D-L2_I-2786301554_TS-TBS_2_FNO-7_12gm2fqa.df
channel ORA_DISK_1: datafile conversion complete, elapsed time: 00:00:01
channel ORA_DISK_1: starting datafile conversion
input datafile fno=00019 name=+DATAFILE/tbs_25.f
converted datafile=/tmp/tbs_2_data_D-L2_I-2786301554_TS-TBS_2_FNO-19_13gm2fqb.df
channel ORA_DISK_1: datafile conversion complete, elapsed time: 00:00:01
channel ORA_DISK_1: starting datafile conversion
input datafile fno=00009 name=+DATAFILE/tbs_23.f
converted datafile=/tmp/tbs_2_data_D-L2_I-2786301554_TS-TBS_2_FNO-9_14gm2fqc.df
channel ORA_DISK_1: datafile conversion complete, elapsed time: 00:00:01
channel ORA_DISK_1: starting datafile conversion
input datafile fno=00010 name=+DATAFILE/tbs_24.f
converted datafile=/tmp/tbs_2_data_D-L2_I-2786301554_TS-TBS_2_FNO-10_15gm2fqd.df
channel ORA_DISK_1: datafile conversion complete, elapsed time: 00:00:01
Finished conversion at 03-JUN-13
```

**Example 2-69 Transporting a Database to a Different Platform**

The arguments to `CONVERT DATABASE` vary depending on whether you plan to convert the data files on the source or destination platform. For a description of the conversion process on

source and destination platforms and extended examples, refer to *Oracle Database Backup and Recovery User's Guide*. Read that discussion in its entirety before attempting a database conversion.

Assume that you want to transport database `prod` on a Linux host to a Windows host. You decide to convert the data files on the source host rather than on the destination host. The following example connects RMAN to the `PROD` database on the Linux host and uses `CONVERT DATABASE NEW DATABASE` to convert the data files and generate the transport script:

```
CONNECT TARGET "sbu@lin01 AS SYSBACKUP"

target database Password: password
connected to target database: PROD (DBID=39525561)

CONVERT DATABASE
  NEW DATABASE 'prodwin'
  TRANSPORT SCRIPT '/tmp/convertldb/transportscript'
  TO PLATFORM 'Microsoft Windows IA (32-bit)'
  DB_FILE_NAME_CONVERT '/disk1/oracle/dbs', '/tmp/convertldb';
```

In the following variation, you want to transport a database running on a Linux host to a Windows host, but you want to convert the data files on the destination host rather than the source host. `sbu` is a user who is granted the `SYSBACKUP` privilege. The following example connects RMAN to the `prod` database on the Linux host and executes `CONVERT DATABASE ON DESTINATION PLATFORM`:

```
CONNECT TARGET "sbu@lin01 AS SYSBACKUP"

target database Password: password
connected to target database: PROD (DBID=39525561)

CONVERT DATABASE
  ON DESTINATION PLATFORM
  CONVERT SCRIPT '/tmp/convertldb/convertscript.rman'
  TRANSPORT SCRIPT '/tmp/convertldb/transportscript.sql'
  NEW DATABASE 'prodwin'
  FORMAT '/tmp/convertldb/%U';
```

The `CONVERT DATABASE ON DESTINATION PLATFORM` command, which is executed on a Linux database, generates a convert script that can be run on the Windows host to convert the data files to the Windows format. The `CONVERT DATABASE` command also generates a transport script.

### Example 2-70 Transporting a Database to a Different Platform and Storage Type

In this scenario, you have a database `prod` on a Solaris host named `sun01` that you want to move to an AIX host named `aix01`. The Solaris data files are stored in a non-ASM file system, but you want to store the data files in ASM on the AIX host.

The following example connects to `sun01` and runs `CONVERT DATABASE` to generate the necessary scripts:

```
CONNECT TARGET "sbu@sun01 AS SYSBACKUP"

target database Password: password
connected to target database: PROD (DBID=39525561)

CONVERT DATABASE
```

```

ON DESTINATION PLATFORM
CONVERT SCRIPT '/tmp/convert_newdb.rman'
TRANSPORT SCRIPT '/tmp/transport_newdb.sql'
NEW DATABASE 'prodaix'
DB_FILE_NAME_CONVERT '/u01/oradata/DBUA/datafile','+DATA';

```

The convert script contains statements of the following form, where *your\_source\_platform* stands for your source platform:

```

CONVERT DATAFILE '/u01/oradata/DBUA/datafile/o1_mf_system_2lg3905p_.dbf'
FROM PLATFORM 'your_source_platform'
FORMAT '+DATA/o1_mf_system_2lg3905p_.dbf';

```

To reduce downtime for the conversion, you can use NFS rather than copying data files over the network or restoring a backup. For example, you could mount the Solaris files system on the AIX host as `/net/solaris/oradata`. In this case, you would edit the convert script to reference the NFS-mounted directory as the location of the source data files to convert, putting the commands into the following form:

```

CONVERT DATAFILE '/net/solaris/oradata/DBUA/datafile/o1_mf_system_2lg3905p_.dbf'
FROM PLATFORM 'your_source_platform'
FORMAT '+DATA/o1_mf_system_2lg3905p_.dbf';

```

You then connect RMAN to the destination database instance, in this case the instance on host `aix01`, and convert the data files. During the conversion, the database at host `sun01` remains in open read only mode. Afterward, you connect SQL\*Plus to the database instance on `aix01` and run the transport script to create the database.

## 2.12 CREATE CATALOG

### Purpose

Use the `CREATE CATALOG` command to create a base recovery catalog. A virtual private catalog is created automatically when catalog privileges are granted to the virtual private catalog owner.

- A base recovery catalog is a database schema that contains RMAN metadata for a set of target databases.
- A virtual private catalog is a set of security policies that restrict user access to a subset of a base recovery catalog.

### See Also:

- *Oracle Database Backup and Recovery User's Guide* to learn how to create the recovery catalog
- "[RMAN Compatibility](#)" to learn about the requirements for the compatibility of the recovery catalog and the other components of the RMAN environment

### Prerequisites

Execute this command only at the RMAN prompt. RMAN must be connected to the recovery catalog database either through the `CATALOG` command-line option or the `CONNECT CATALOG`

command, and the catalog database must be open. A connection to a target database is not required.

The recovery catalog owner for the base recovery catalog must be granted the `RECOVERY_CATALOG_OWNER` role. The recovery catalog is created in the default tablespace of the recovery catalog owner.

You must have run the `dbmsrmansys.sql` script to grant additional privileges that are required for the `RECOVERY_CATALOG_OWNER` role.

 **Note:**

Starting with Oracle Database 12c Release 1 (12.1.0.2), the recovery catalog database must use the Enterprise Edition.

The database user who owns a virtual private catalog must be granted the `CREATE SESSION` privilege. Starting with Oracle Database 12c Release 1 (12.1.0.2), virtual private catalogs can be created only when using Oracle Database Enterprise Edition.

If you are creating a virtual private catalog, then:

- You must use SQL\*Plus to connect to the recovery catalog database as the `SYS` user with `SYSDBA` privilege.
- The base recovery catalog owner must have used the `RMAN GRANT` command to grant either the `CATALOG` or `REGISTER` privilege (see [Example 2-72](#)).

See the `CONNECT CATALOG` description for restrictions for RMAN client connections to a virtual catalog when the RMAN client is from release Oracle Database 10g or earlier.

### Usage Notes

Typically, you create the recovery catalog in a database created especially for this purpose. Do not create the recovery catalog in a privileged schema such as `SYS` or `SYSBACKUP`.

The best practice is to create one recovery catalog that serves as the central RMAN repository for many databases. For this reason it is called the **base recovery catalog**.

The owner of the base recovery catalog can `GRANT` or `REVOKE` restricted access to the catalog to other database users. Each restricted user has full read/write access to his own metadata, which is called a **virtual private catalog**. The RMAN metadata is stored in the schema of the virtual private catalog owner. The owner of the base recovery catalog controls what each virtual catalog user can access.

### Syntax

**`createCatalog::=`**



## Examples

### Example 2-71 Creating a Recovery Catalog and Registering a Database

Assume that you start SQL\*Plus and connect to the recovery catalog `catdb` with administrator privileges. You execute the `CREATE USER` statement as follows, replacing `password` with a user-specified password (see *Oracle Database Security Guide* for information on creating secure passwords). The SQL statement creates a user `rco` in database `catdb` and grant the `rco` user the `RECOVERY_CATALOG_OWNER` role.

```
SQL> CREATE USER rco IDENTIFIED BY password
  2  DEFAULT TABLESPACE cattbs
  3  QUOTA UNLIMITED ON cattbs;
SQL> GRANT recovery_catalog_owner TO rco;
SQL> EXIT
```

Next, you run the `dbmsrmansys.sql` script to grant additional privileges that are required for the `RECOVERY_CATALOG_OWNER` role.

```
SQL> @$ORACLE_HOME/rdbms/admin/dbmsrmansys.sql
```

You then start RMAN and run the following RMAN commands to connect to the recovery catalog database as `rco` and create the recovery catalog:

```
RMAN> CONNECT CATALOG rco@catdb

recovery catalog database Password: password
connected to recovery catalog database

RMAN> CREATE CATALOG;
```

In the same RMAN session, you connect to a target database using operating system authentication and use the `REGISTER DATABASE` command to register this database in the catalog:

```
RMAN> CONNECT TARGET /
RMAN> REGISTER DATABASE;
RMAN> EXIT
```

### Example 2-72 Creating a Virtual Private Catalog

Assume that you created the recovery catalog and registered a database as shown in [Example 2-71](#). Now you want to create a virtual private catalog for database user `vpc1`. The database version is Oracle Database 12c Release 1 (12.1.0.2). You start SQL\*Plus and connect to recovery catalog database `catdb` as the `SYS` user with `SYSDBA` privilege.

You create the `vpc1` user and grant recovery catalog ownership as follows, replacing `password` with a user-specified password (see *Oracle Database Security Guide* for information on creating secure passwords):

```
SQL> CREATE USER vpc1 IDENTIFIED BY password
  2  DEFAULT TABLESPACE vpcusers;
SQL> GRANT CREATE SESSION TO vpc1;
SQL> EXIT
```

You then start RMAN and connect to the recovery catalog database as the catalog owner `rco`. By default, the virtual catalog owner has no access to the base recovery catalog. You

use the [GRANT](#) command to grant virtual private catalog access to `vpcl` for RMAN operations on database `prod1` (but not `prod2`):

```
RMAN> CONNECT CATALOG rco@catdb

recovery catalog database Password: password
connected to recovery catalog database

RMAN> GRANT CATALOG FOR DATABASE prod1 TO vpcl;
RMAN> EXIT;
```

Now the backup operator who will use virtual private catalog `vpcl` is ready to create the virtual catalog. In the following example, the backup operator connects to the recovery catalog database as `vpcl` and registers the database `prod1` with `vpcl`.

The virtual private catalog is created automatically when catalog privileges are granted to the virtual private catalog owner.

```
RMAN> CONNECT CATALOG vpcl@catdb

recovery catalog database Password: password
connected to recovery catalog database

RMAN> REGISTER DATABASE prod1;
RMAN> EXIT;
```

## 2.13 CREATE SCRIPT

### Purpose

Use the `CREATE SCRIPT` command to create a stored script in the recovery catalog. A stored script is a sequence of RMAN commands that is given a name and stored in the recovery catalog for later execution.

#### See Also:

- *Oracle Database Backup and Recovery User's Guide* to learn how to use stored scripts
- [REPLACE SCRIPT](#) to learn how to update a stored script

### Prerequisites

Execute `CREATE SCRIPT` only at the RMAN prompt. RMAN must be connected to a target database and a recovery catalog. The recovery catalog database must be open.

If `GLOBAL` is specified, then a global script with this name must not already exist in the recovery catalog. If `GLOBAL` is not specified, then a local script must not already exist with the same name for the same target database. In you do not meet these prerequisites, then RMAN returns error `RMAN-20401`.

## Usage Notes

A stored script may be local or global. A local script is created for the current target database only, whereas a global script is available for use with any database registered in the recovery catalog.

It is permissible to create a global script with the same name as a local script, or a local script with the same name as a global script.

## Substitution Variables in Stored Scripts

RMAN supports the use of substitution variables in a stored script. &1 indicates where to place the first value, &2 indicate where to place the second value, and so on. Special characters must be quoted.

The substitution variable syntax is *&integer* followed by an optional period, for example, &1.3. The optional period is part of the variable and replaced with the value, thus enabling the substitution text to be immediately followed by another integer. For example, if you pass the value `mybackup` to a command file that contains the substitution variable `&1.3`, then the result of the substitution is `mybackup3`. To create the result `mybackup.3`, use two periods in the syntax `&1..3`.

When you create a stored script with substitution variables, you must provide example values at create time. You can provide these values with the `USING` clause when starting RMAN (see [RMAN](#)) or enter them when prompted (see [Example 2-75](#)).

## Syntax

**createScript::=**

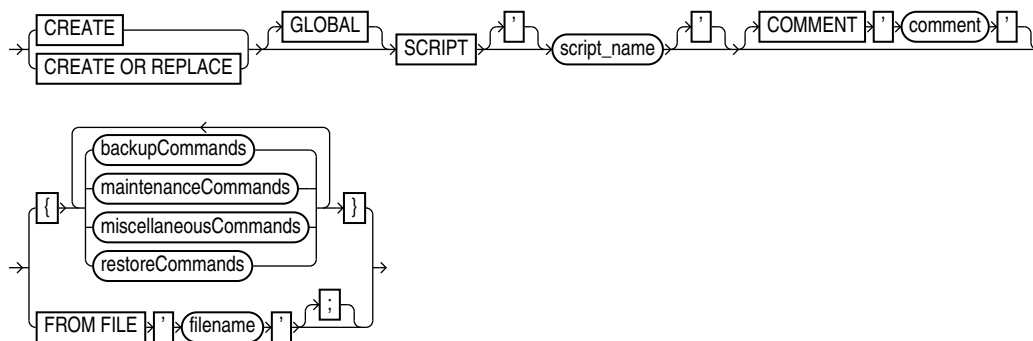

`backupCommands::=`, `maintenanceCommands::=`, `miscellaneousCommands::=`,  
`restoreCommands::=`)

## Semantics

Syntax Element	Description
CREATE OR REPLACE	Creates a new script, if a script with the specified name does not exist. If a script with the specified name already exists, it is recreated.



Syntax Element	Description
GLOBAL	Identifies the script as global. <b>Note:</b> A virtual private catalog has read-only access to global scripts. Creating or updating global scripts must be done while connected to the base recovery catalog.
SCRIPT <i>script_name</i>	Specifies the name of the script. Quotes must be used around the script name when the name contains either spaces or reserved words.
COMMENT ' <i>comment</i> '	Associates an explanatory comment with the stored script in the recovery catalog. The comment is used in the output of <a href="#">LIST SCRIPT NAMES</a> .
<i>backupCommands</i> <i>maintenanceCommands</i> <i>miscellaneousCommands</i> <i>restoreCommands</i>	Specifies commands to include in the stored script. The commands allowable within the brackets of the <code>CREATE SCRIPT '<i>script_name</i>' {...}</code> command are the same commands supported within a <a href="#">RUN</a> command. Any command that is valid within a <code>RUN</code> command is permitted in the stored script. The following commands are not valid within stored scripts: <code>RUN</code> , <code>@</code> (at sign), and <code>@@</code> (double at sign).
FROM FILE ' <i>filename</i> '	Reads the sequence of commands to define the script from the specified file. The file looks like the body of a valid stored script. The first line of the file must be a left brace ( { ) and the last line must contain a right brace ( } ). The <code>RMAN</code> commands in the file must be valid in a stored script.

## Examples

### Example 2-73 Creating a Local Stored Script

Assume that you want to create a local stored script for backing up database `prod`. You start `RMAN`, connect to `prod` as `TARGET`, and connect to a recovery catalog. You create a stored script called `backup_whole` and then use [EXECUTE SCRIPT](#) to run it as follows:

```
CREATE SCRIPT backup_whole
COMMENT "backup whole database and archived redo log files"
{
    BACKUP
        INCREMENTAL LEVEL 0 TAG backup_whole
        FORMAT "/disk2/backup/%U"
        DATABASE PLUS ARCHIVELOG;
}
RUN { EXECUTE SCRIPT backup_whole; }
```

### Example 2-74 Creating a Global Stored Script

This example connects `RMAN` to target database `prod` and recovery catalog database `catdb` as catalog user `rco`. The example creates a global script called `global_backup_db` that backs up the database and archived redo log files:

```
RMAN> CONNECT TARGET "sbu@prod AS SYSBACKUP"

target database Password: password
connected to target database: PROD (DBID=39525561)

RMAN> CONNECT CATALOG rco@catdb

recovery catalog database Password: password
connected to recovery catalog database
```

```
RMAN> CREATE GLOBAL SCRIPT global_backup_db { BACKUP DATABASE PLUS ARCHIVELOG; }
RMAN> EXIT;
```

You can now connect RMAN to a different target database such as `prod2` and run the global stored script:

```
RMAN> CONNECT TARGET "sbu@prod2 AS SYSBACKUP"

target database Password: password
connected to target database: PROD2 (DBID=36508508)

RMAN> CONNECT CATALOG rco@catdb

recovery catalog database Password: password
connected to recovery catalog database

RMAN> RUN { EXECUTE SCRIPT global_backup_db; }
```

### Example 2-75 Creating a Stored Script That Uses Substitution Variables

The following example connects RMAN to a target database and recovery catalog and uses [CREATE SCRIPT](#) to create a backup script that includes three substitution variables. RMAN prompts you to enter initial values for the variables (user input is shown in bold).

```
RMAN> CONNECT TARGET /
RMAN> CONNECT CATALOG rco@catdb

recovery catalog database Password: password
connected to recovery catalog database

RMAN> CREATE SCRIPT backup_df
2> { BACKUP DATAFILE &1 TAG &2.1 FORMAT '/disk1/&3_%U'; }
  Enter value for 1: 1

Enter value for 2: df1_backup

Enter value for 3: df1

starting full resync of recovery catalog
full resync complete
created script backup_df
```

When you run [EXECUTE SCRIPT](#), you can pass different values to the script. The following example passes the values `3`, `test_backup`, and `test` to the substitution variables in the stored script:

```
RMAN> RUN { EXECUTE SCRIPT backup_df USING 3 test_backup df3; }
```

After the values are substituted, the script executes as follows:

```
BACKUP DATAFILE 3 TAG test_backup1 FORMAT '/disk1/df3_%U';
```

## 2.14 CROSSCHECK

### Purpose

Use the `CROSSCHECK` command to synchronize the physical reality of backups and copies with their logical records in the RMAN repository.

 **Note:**

A multitenant container database is the only supported architecture in Oracle Database 21c. While the documentation is being revised, legacy terminology may persist. In most cases, "database" and "non-CDB" refer to a CDB or PDB, depending on context. In some contexts, such as upgrades, "non-CDB" refers to a non-CDB from a previous release.

 **See Also:**

*Oracle Database Backup and Recovery User's Guide* to learn how to manage database records in the recovery catalog

### Prerequisites

RMAN must be connected to a target database instance, which must be started.

A maintenance channel is not required for a disk cross-check. If you use a media manager and have not configured automatic channels for it, then you must use run [ALLOCATE CHANNEL FOR MAINTENANCE](#) before `CROSSCHECK`. For example, if you created a backup on an SBT channel, but have not configured automatic SBT channels for this device, then you must manually allocate an SBT channel before `CROSSCHECK` can check the backup. Furthermore, if you performed backups with different media manager options (pools, servers, libraries, and so on), then you must allocate maintenance channels for each combination.

`CROSSCHECK` validates all specified backups and copies, even if they were created in previous database incarnations.

For preplugin backups, the CDB must be open in read-write mode and you must connect as a common user with the `SYSDBA` or `SYSBACKUP` privilege.

### Usage Notes

RMAN always maintains metadata about backups in the control file of every target database on which it performs operations. If you use RMAN with a recovery catalog, then RMAN also maintains the metadata from every registered database in the recovery catalog.

If a backup is on disk, then `CROSSCHECK` determines whether the header of the file is valid. If a backup is on tape, then RMAN queries the RMAN repository for the names and locations of the backup pieces to be checked. RMAN sends this metadata to the target database server, which queries the media management software about the backups. The media management software then checks its media catalog and reports back to the server with the status of the backups.

### EXPIRED and AVAILABLE Status

You can view the status of backup sets and copies recorded in the RMAN repository through [LIST](#), `v$` views, or recovery catalog views (if you use RMAN with a catalog). [Table 2-4](#) describes the meaning of each status.

The `CROSSCHECK` command only processes files created on the same device type as the channels used for the cross-check. The `CROSSCHECK` command checks only objects marked `AVAILABLE` or `EXPIRED` in the repository by examining the files on disk for `DISK` channels or by querying the media manager for `sbt` channels.

**Table 2-4 Meaning of CROSSCHECK Status**

Status	Description
EXPIRED	<p>Object is not found either in file system (for <code>DISK</code>) or in the media manager (for <code>sbt</code>). A backup set is <code>EXPIRED</code> if any backup piece in the set is <code>EXPIRED</code>.</p> <p>The <code>CROSSCHECK</code> command does not delete the repository records of files that it does not find, but updates their repository records to <code>EXPIRED</code>. You can run <code>DELETE EXPIRED</code> to remove the repository records for expired files and any existing physical files whose status is <code>EXPIRED</code>.</p> <p>If backups are <code>EXPIRED</code>, then you can reexecute the cross-check later and determine whether expired backups are available. This precaution is especially useful when you use RMAN with a media manager. For example, if some backup pieces or copies were erroneously marked as <code>EXPIRED</code> because the <code>PARMS</code> channel settings were incorrect, then after ensuring that the files really do exist in the media manager, run the <code>CROSSCHECK BACKUP</code> command again to restore those files to <code>AVAILABLE</code> status.</p>
AVAILABLE	<p>Object is available for use by RMAN. For a backup set to be <code>AVAILABLE</code>, all backup pieces in the set must have the status <code>AVAILABLE</code>.</p>

### Cross-Checks in a Data Guard Environment

"[RMAN Backups in a Data Guard Environment](#)" explains the difference between the association and accessibility of a backup. In a Data Guard environment, the database that creates a backup or copy is associated with the file. You can use maintenance commands such as `CHANGE`, `DELETE`, and `CROSSCHECK` for backups when connected to any database in the Data Guard environment if the backups are accessible. In general, RMAN considers tape backups created on any database as accessible to all databases in the environment, whereas disk backups are accessible only to the database that created them.

RMAN can only update the status of a backup from `AVAILABLE` to `EXPIRED` or `DELETED` when connected as `TARGET` to the database associated with the backup. If RMAN cannot delete a backup because it is not associated with the target database, then RMAN prompts you to perform the same `CROSSCHECK` operation for the file at the database with which it is associated. In this way RMAN protects against unwanted status changes that result from incorrect SBT configurations.

For example, assume that you connect RMAN as `TARGET` to standby database `standby1` and back it up to tape. If the backup is manually removed from the tape, and if you perform a cross-check of the backup on `standby2`, then RMAN prompts you to run the cross-check on `standby1`. A cross-check on `standby1` updates the status of the tape backup to `EXPIRED` when the media manager reports that the backup has been deleted.

### Syntax

**`crosscheck::=`**



***maintSpec*::=**

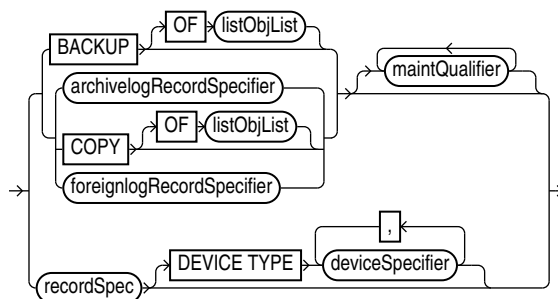

([listObjList](#)::=, [archivelogRecordSpecifier](#)::=, [foreignlogRecordSpecifier](#)::=, [maintQualifier](#)::=, [recordSpec](#)::=, [deviceSpecifier](#)::=)

### Semantics

Syntax Element	Description
PREPLUGIN	Cross-checks preplugin backups. The preplugin backups can be that of a non-CDB or a PDB, before they were plugged in to the current CDB as a PDB.
<a href="#">maintSpec</a>	Cross-checks backups. For <i>maintSpec</i> options, refer to the parameter descriptions in <a href="#">maintSpec</a> .

### Examples

#### Example 2-76 Cross-Checking All Backups and Copies

This example, which assumes that the default configured channel is `DEVICE TYPE sbt`, cross-checks all backups and disk (partial output is included). Because RMAN preconfigures a disk channel, you do not need to manually allocate a disk channel.

```
RMAN> CROSSCHECK BACKUP;
```

```

allocated channel: ORA_SBT_TAPE_1
channel ORA_SBT_TAPE_1: SID=84 device type=SBT_TAPE
channel ORA_SBT_TAPE_1: Oracle Secure Backup
allocated channel: ORA_DISK_1
channel ORA_DISK_1: SID=86 device type=DISK
backup piece handle=/disk2/backup/08i9umon_1_1 RECID=7 STAMP=614423319
crosschecked backup piece: found to be 'EXPIRED'
backup piece handle=/disk2/backup/09i9umso_1_1 RECID=8 STAMP=614423448
crosschecked backup piece: found to be 'EXPIRED'
backup piece handle=/disk1/cfauto/c-26213402-20130213-00 RECID=9 STAMP=614423452
crosschecked backup piece: found to be 'AVAILABLE'
backup piece handle=0bi9uo81_1_1 RECID=10 STAMP=614424833
crosschecked backup piece: found to be 'AVAILABLE'
backup piece handle=c-26213402-20130213-01 RECID=11 STAMP=614424851
crosschecked backup piece: found to be 'AVAILABLE'

```

·  
·  
·

### Example 2-77 Cross-Checking Within a Range of Dates

This example queries the media manager for the status of the backup sets in a given six week range. RMAN uses the date format specified in the `NLS_DATE_FORMAT` parameter, which is 'DD-MON-YY' in this example. The first command cross-checks backups on tape only:

```
ALLOCATE CHANNEL FOR MAINTENANCE DEVICE TYPE sbt;
CROSSCHECK BACKUP
  COMPLETED BETWEEN '01-JAN-13' AND '14-FEB-13';
RELEASE CHANNEL;
```

The following command specifies `DEVICE TYPE DISK` to cross-check only disk:

```
CROSSCHECK BACKUP DEVICE TYPE DISK
  COMPLETED BETWEEN '01-JAN-13' AND '14-FEB-13';
```

If the default channel is SBT, then you can cross-check both disk and SBT backups by running `CROSSCHECK` with the default channels:

```
CROSSCHECK BACKUP COMPLETED BETWEEN '01-JAN-13' AND '14-FEB-13';
```

## 2.15 DELETE

### Purpose

Use the `DELETE` command to perform the following actions:

- Delete physical backups and copies.
- Delete obsolete backups of sparse databases.
- Update the repository records in the target control file to show that the files are deleted. For example, the record for a backup piece in `V$BACKUP_PIECE.STATUS` shows the value `D`.
- Remove the repository records for deleted files from the recovery catalog (if you use a catalog). For example, `RC_BACKUP_PIECE` no longer contains a row for a deleted backup piece.



#### See Also:

[BACKUP](#) to learn about the `BACKUP ... DELETE INPUT` command

### Prerequisites

RMAN must be connected to a target database, which must be mounted or open.

RMAN uses all configured channels to perform the deletion. If you use `DELETE` for files on devices that are *not* configured for automatic channels, then you must use [ALLOCATE CHANNEL FOR MAINTENANCE](#). For example, if you made a backup with an SBT channel, but only a disk channel is configured, then you must manually allocate an SBT channel for

DELETE. An automatic or manually allocated maintenance channel is required when you use DELETE on a disk-only file.

For preplugin backups, the CDB must be open in read-write mode and you must connect as a common user with the SYSDBA or SYSBACKUP privilege.

### Usage Notes

The best practice is to run CROSSCHECK to update the status of backups and copies in the repository and then run DELETE to remove the desired files. When running RMAN interactively, DELETE displays a list of files and prompts for confirmation before deleting any file in the list. If you confirm, then RMAN shows each item as it is deleted. When reading commands from a command file, RMAN does not prompt for confirmation.

You can view the status of backups and copies recorded in the RMAN repository through LIST, V\$ views, or recovery catalog views (if you use a catalog). The repository record for a backup can fail to reflect its physical status. For example, a user deletes a disk backup with the Linux rm command. The backup record cannot be updated by rm, so the RMAN repository shows the file as available although it no longer exists.

### Behavior of DELETE Command for Files of Different Status Values

Table 2-5 describes the behavior of DELETE when the FORCE option is not specified.

**Table 2-5 Behavior of DELETE Command Without FORCE Option**

Repository Status	Physical Status	Behavior of DELETE Command
AVAILABLE	Not found on media	Does not delete the object and reports the list of mismatched objects at the end of the job. RMAN does not update the repository status.
EXPIRED	Found on media	Does not delete the object and reports the list of mismatched objects at the end of the job. RMAN does not update the repository status.
UNAVAILABLE	Any	Removes repository record and deletes object if it exists. All I/O errors are ignored.

### Backup Deletion in a Data Guard Environment

"RMAN Backups in a Data Guard Environment" explains the difference between the association and accessibility of a backup. In a Data Guard environment, the database that creates a backup or copy is associated with the file. You can use maintenance commands such as CHANGE, DELETE, and CROSSCHECK for backups when connected to any database in the Data Guard environment if the backups are accessible. In general, RMAN considers tape backups created on any database as accessible to all databases in the environment, whereas disk backups are accessible only to the database that created them.

If a deletion is successful, then RMAN removes the metadata for the file, even if the file is associated with another database. If a deletion was not successful, and if the file is associated with another database in the Data Guard environment, then RMAN prompts you to perform the same DELETE command while connected as TARGET to the database associated with the file. You must use DELETE . . . FORCE to delete the file metadata.

**Syntax**

**delete::=**

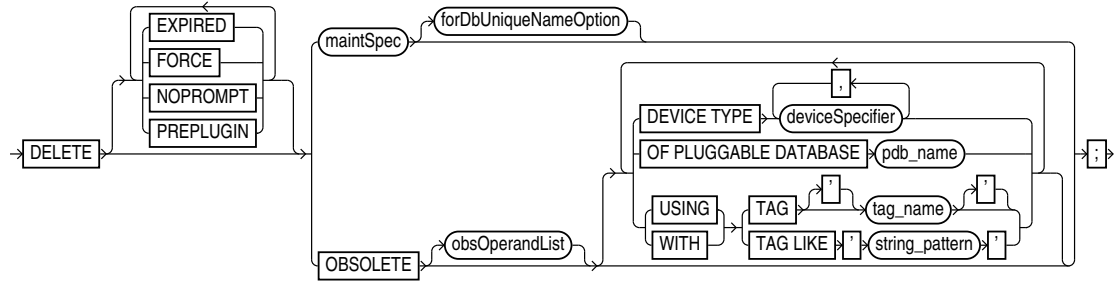

(maintSpec::=, obsOperandList::=, deviceSpecifier::=)

**maintSpec::=**

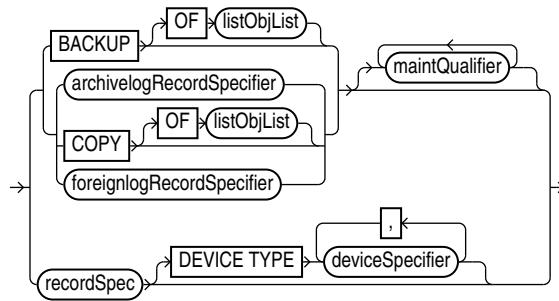

(listObjList::=, archivelogRecordSpecifier::=, maintQualifier::=, deviceSpecifier::=, recordSpec::=)

**forDbUniqueNameOption::=**

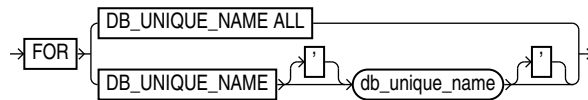

**Semantics**

Syntax Element	Description
FORCE	Deletes specified files—whether or not they exist on the media—and removes repository records (see <a href="#">Example 2-81</a> ). RMAN ignores any I/O errors for the deleted objects. RMAN also ignores any <a href="#">CONFIGURE ARCHIVELOG DELETION POLICY</a> settings. RMAN displays the number of deleted objects at the end of the job.



Syntax Element	Description
NOPROMPT	Deletes specified files without first listing the files or prompting for confirmation. The <code>DELETE NOPROMPT</code> command displays each item as it is deleted.
PREPLUGIN	Deletes preplugin backups and removes their repository records.
EXPIRED	Removes only files whose status in the repository is <code>EXPIRED</code> (see <a href="#">Example 2-78</a> ). RMAN marks backups and copies as expired when you run a <code>CROSSCHECK</code> command and the files are absent or inaccessible. To determine which files are expired, run a <code>LIST EXPIRED</code> command.  If for some reason a backup marked <code>EXPIRED</code> exists when you run the <code>DELETE EXPIRED</code> command, then RMAN does not delete the physical file.
<a href="#">maintSpec</a>	Deletes backups and copies.  You can set rules for the deletion with the <a href="#">maintQualifier</a> clause. For example, you can delete archived redo log files that are backed up to tape (see <a href="#">Example 2-80</a> ).  When deleting backups of PDBs that were dropped, you identify the PDB using its GUID. Use the <code>GUID</code> clause with the <code>DELETE</code> command to delete backups of dropped PDBs. The <code>dba_pdb_history</code> view contains the GUID of dropped PDBs.  <b>Note:</b> <code>DELETE ARCHIVELOG ALL</code> considers only the archived log deletion policy and does not consider the configured retention policy.  <b>Note:</b> In CDBs, you must connect to the root as a user with the <code>SYSDBA</code> or <code>SYSBACKUP</code> privilege to delete archived redo logs. You cannot delete archived redo logs when connected to a PDB.  <b>See Also:</b> <a href="#">maintSpec</a> and <a href="#">maintQualifier</a>
<a href="#">forDbUniqueNameOption</a>	Deletes the backups and copies in <a href="#">maintSpec</a> that are exclusively associated with the specified <code>DB_UNIQUE_NAME</code> in a Data Guard environment.  <b>Note:</b> The <code>FOR DB_UNIQUE_NAME</code> option is not allowed with the <code>DELETE OBSOLETE</code> command.  If RMAN successfully deletes tape backups associated with the specified <code>DB_UNIQUE_NAME</code> , then RMAN removes the metadata for these files from the recovery catalog. If RMAN could not delete these files because they are associated with a different database in the Data Guard environment, then RMAN prompts you to perform the same <code>DELETE</code> operation for these files at the database that is associated with them.  <b>Note:</b> You cannot use <code>FORCE</code> to override the default behavior and specify that RMAN deletes files that are associated with a different database. In this way, RMAN protects you from accidental deletions caused by incorrect RMAN configurations for SBT. To remove the metadata for files that RMAN prevents you from deleting, use the <code>CHANGE RESET DB_UNIQUE_NAME</code> command.  <b>See Also:</b> <a href="#">forDbUniqueNameOption</a> for descriptions of the options in this clause

Syntax Element	Description
OBSOLETE	<p>Deletes data file backups and copies recorded in the RMAN repository that are obsolete, that is, no longer needed (see <a href="#">Example 2-79</a>). RMAN also deletes obsolete archived redo log files and log backups.</p> <p>RMAN determines which backups and copies of data files are no longer needed, which in turn determines when logs (and backups of logs) are no longer needed. RMAN considers the creation of a data file as a backup when deciding which logs to keep.</p> <p>RMAN first uses the options specified with <a href="#">obsOperandList</a> to determine which files are obsolete. If you do not specify options in <a href="#">obsOperandList</a>, then RMAN uses the options specified in <code>CONFIGURE RETENTION POLICY</code>.</p> <p><b>Note:</b> <code>DELETE OBSOLETE</code> considers only the backup retention policy and does not use the configured archived log deletion policy to determine which logs are obsolete. In contrast, <code>DELETE ARCHIVELOG ALL</code> considers only the configured archived log deletion policy.</p> <p><b>Note:</b> If you make a backup with the <code>KEEP UNTIL TIME</code> clause, then this backup becomes obsolete after the specified <code>KEEP</code> time passes and is removed by <code>DELETE OBSOLETE</code>. RMAN does not consider the backup retention policy for archival backups whose <code>KEEP</code> time has expired.</p> <p><b>Note:</b> The <code>DELETE . . . OBSOLETE</code> command cannot be used when backups are stored to Zero Data Loss Recovery Appliance, commonly known as Recovery Appliance.</p>
<a href="#">obsOperandList</a>	<p>Specifies the criteria for determining which backups and copies are obsolete.</p> <p><b>See Also:</b> <a href="#">obsOperandList</a></p>
<code>DEVICE TYPE</code> <a href="#">deviceSpecifier</a>	<p>Restricts the deletion to obsolete backups and copies created on the specified device type only.</p> <p><b>See Also:</b> <a href="#">deviceSpecifier</a></p>
<code>OF PLUGGABLE DATABASE</code> <i>pdb_name</i>	<p>Restricts the deletion to obsolete backups and copies of the PDB <i>pdb_name</i>.</p>
<code>TAG tag_name</code>	<p>Restricts the deletion to obsolete backups and copies with the TAG specified by <i>tag_name</i>.</p>
<code>TAG LIKE</code> <i>string_pattern</i>	<p>Restricts the deletion to obsolete backups and copies with TAG values that match the specified string pattern.</p>

## Examples

### Example 2-78 Deleting Expired Backups

This example uses a configured `sbt` channel to check the media manager for expired backups of the tablespace `users` that are more than one month old and removes their recovery catalog records.

```
CROSSCHECK BACKUPSET OF TABLESPACE users
  DEVICE TYPE sbt COMPLETED BEFORE 'SYSDATE-31';
DELETE NOPROMPT EXPIRED BACKUPSET OF TABLESPACE users
  DEVICE TYPE sbt COMPLETED BEFORE 'SYSDATE-31';
```

### Example 2-79 Deleting Obsolete Backups

This example deletes backups and copies that are not needed to recover the database to an arbitrary SCN within the last week. RMAN also deletes archived redo log files that are no longer needed.

```
DELETE NOPROMPT OBSOLETE RECOVERY WINDOW OF 7 DAYS;
```

### Example 2-80 Deleting Archived Redo Log Files That Are Backed Up

Assume that you have configured RMAN settings as follows:

```
CONFIGURE DEFAULT DEVICE TYPE TO sbt;
CONFIGURE ARCHIVELOG DELETION POLICY TO
  BACKED UP 2 TIMES
  TO DEVICE TYPE sbt;
```

The following `DELETE` command deletes all archived redo log files on disk if they are not needed to meet the configured deletion policy, which specifies that logs must be backed up twice to tape (sample output included):

```
RMAN> DELETE ARCHIVELOG ALL;
```

```
allocated channel: ORA_DISK_1
channel ORA_DISK_1: SID=84 device type=DISK
```

```
List of Archived Log Copies for database with db_unique_name PROD
```

```
=====
```

Key	Thrd	Seq	S	Low Time
107	1	4	A	12-FEB-13
	Name: /orcva/PROD/archivelog/2013_02_12/ol_mf_1_4_2x28bpcm_.arc			
108	1	5	A	12-FEB-13
	Name: /orcva/PROD/archivelog/2013_02_12/ol_mf_1_5_2x28g7s9_.arc			
109	1	6	A	12-FEB-13
	Name: /orcva/PROD/archivelog/2013_02_13/ol_mf_1_6_2x3bbqym_.arc			
157	1	7	A	13-FEB-13
	Name: /orcva/PROD/archivelog/2013_02_13/ol_mf_1_7_2x3w2cvs_.arc			
164	1	8	A	13-FEB-13
	Name: /orcva/PROD/archivelog/2013_02_13/ol_mf_1_8_2x3w40vr_.arc			
171	1	9	A	13-FEB-13
	Name: /orcva/PROD/archivelog/2013_02_13/ol_mf_1_9_2x3w8pf7_.arc			
318	1	10	A	13-FEB-13
	Name: /orcva/PROD/archivelog/2013_02_13/ol_mf_1_10_2x3zx6d9_.arc			
330	1	11	A	13-FEB-13
	Name: /orcva/PROD/archivelog/2013_02_13/ol_mf_1_11_2x403wco_.arc			
448	1	12	A	13-FEB-13
	Name: /orcva/PROD/archivelog/2013_02_13/ol_mf_1_12_2x40wn6x_.arc			
455	1	13	A	13-FEB-13
	Name: /orcva/PROD/archivelog/2013_02_13/ol_mf_1_13_2x412s3m_.arc			
583	1	14	A	13-FEB-13
	Name: /orcva/PROD/archivelog/2013_02_13/ol_mf_1_14_2x428p9d_.ar			
638	1	15	A	13-FEB-13
	Name: /orcva/PROD/archivelog/2013_02_13/ol_mf_1_15_2x42f0gj_.arc			

```
Do you really want to delete the above objects (enter YES or NO)?
```

### Example 2-81 Forcing the Deletion of a Backup Set

The following example attempts to delete the backup set copy with tag `weekly_bkup`:

```
RMAN> DELETE NOPROMPT BACKUPSET TAG weekly_bkup;
```

RMAN displays a warning because the repository shows the backup set as available, but the object is not actually available on the media:

```

List of Backup Pieces
BP Key  BS Key  Pc# Cp# Status      Device Type Piece Name
-----  -
809     806     1  1  AVAILABLE  SBT_TAPE   Ori9uu08_1_1

RMAN-06207: WARNING: 1 objects could not be deleted for SBT_TAPE channel(s) due
RMAN-06208:           to mismatched status. Use CROSSCHECK command to fix status
RMAN-06210: List of Mismatched objects
RMAN-06211: =====
RMAN-06212:  Object Type  Filename/Handle
RMAN-06213: -----
RMAN-06214: Backup Piece  Ori9uu08_1_1

```

The following command forces RMAN to delete the backup set (sample output included):

```

RMAN> DELETE FORCE NOPROMPT BACKUPSET TAG weekly_bkup;

using channel ORA_SBT_TAPE_1
using channel ORA_DISK_1

List of Backup Pieces
BP Key  BS Key  Pc# Cp# Status      Device Type Piece Name
-----  -
809     806     1  1  AVAILABLE  SBT_TAPE   Ori9uu08_1_1
deleted backup piece
backup piece handle=Ori9uu08_1_1 RECID=26 STAMP=614430728
Deleted 1 objects

```

## 2.16 DELETE SCRIPT

### Purpose

Use the `DELETE SCRIPT` command to delete a local or global stored script from the recovery catalog.

### Prerequisites

Execute `DELETE SCRIPT` only at the RMAN prompt. RMAN must be connected to a recovery catalog and target database. The recovery catalog database must be open.

### Usage Notes

A stored script may be local or global. A local script is created for the current target database only, whereas a global script is available for use with any database registered in the recovery catalog.

If `GLOBAL` is specified, then a global script with this name must exist in the recovery catalog; otherwise, RMAN returns error `RMAN-06710`. If you do not specify `GLOBAL`, then RMAN looks for a local stored script with the specified name defined on the current target database. If no such script is defined on the target database, then RMAN checks for a global stored script with this name and deletes it if it exists.

### Syntax

**`deleteScript::=`**



## Semantics

Syntax Element	Description
GLOBAL	Identifies the script as global. If you attempt to delete a global script, then RMAN must not be connected to a virtual private catalog. Virtual catalog users cannot modify global scripts, although they can execute them. <b>See Also:</b> <a href="#">"Usage Notes"</a> for an explanation of the difference between global and local scripts
SCRIPT <i>script_name</i>	Specifies the name of the script to delete. Quotes must be used around the script name when the name contains either spaces or reserved words.

### Example

#### Example 2-82 Deleting a Global Script

This example deletes global script `backup_db` from the recovery catalog (sample output included):

```
RMAN> LIST SCRIPT NAMES;
```

```
List of Stored Scripts in Recovery Catalog
```

```
Scripts of Target Database PROD
```

```
Script Name  
Description
```

```
-----  
backup_whole  
backup whole database and archived redo log files
```

```
Global Scripts
```

```
Script Name  
Description
```

```
-----  
global_backup_db  
back up any database from the recovery catalog, with logs
```

```
RMAN> DELETE GLOBAL SCRIPT global_backup_db;
```

```
deleted global script: global_backup_db
```

```
RMAN> LIST SCRIPT NAMES;
```

```
List of Stored Scripts in Recovery Catalog
```

```
Scripts of Target Database PROD
```

```
Script Name  
Description
```

```
-----
```

```
backup_whole
backup whole database and archived redo log files
```

## 2.17 DESCRIBE

### Purpose

Use the `DESCRIBE` command to list the column definitions of a table or view.

This command provides the functionality of the SQL\*Plus `DESCRIBE` command within RMAN.

### Prerequisites

To access a table or view in another schema, you must have `READ` or `SELECT` privileges on the object or connect in `AS SYSDBA` mode. The `SYSBACKUP` privilege does not grant access to user tables or views.

### Usage Notes

Descriptions provide this information for each column in the table or view:

- Name
- Whether null values are permitted (`NULL` or `NOT NULL`)
- Data type and, where applicable, the precision or scale

### Syntax

***describecmd::=***

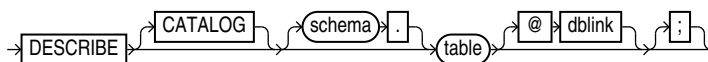

### Semantics

Syntax Element	Description
CATALOG	Identifies the object as residing in the database containing the recovery catalog,
<i>schema</i>	Schema location of the table or view, required only when it is not in your login schema.
<i>table</i>	Name of a table or view.
<i>dblink</i>	Database link name for the database where the object exists, required only when it is not in the login database.

### Examples

This example describes the `V$CONTROLFILE` table:

```
RMAN> desc v$controlfile
Name                               Null?    Type
-----
STATUS                              VARCHA2 (7)
NAME                                VARCHA2 (513)
IS_RECOVERY_DEST_FILE               VARCHA2 (3)
BLOCK_SIZE                           NUMBER
```

FILE\_SIZE\_BLKs  
CON\_IDNUMBER  
NUMBER

## 2.18 DROP CATALOG

### Purpose

Use the `DROP CATALOG` command to remove the recovery catalog.

#### See Also:

*Oracle Database Backup and Recovery User's Guide* to learn how to drop the recovery catalog

### Prerequisites

Execute this command only at the RMAN prompt.

You must be connected to the recovery catalog schema with the `CATALOG` command-line option or the `CONNECT CATALOG` command. The recovery catalog database must be open.

You do not have to be connected to a target database.

### Usage Notes

After you execute `DROP CATALOG`, RMAN prompts you to enter the command again to confirm that you want to perform the operation.

To bypass the command confirmation step, execute the `DROP CATALOG` command with the `NOPROMPT` option when you run it the first time.

A base recovery catalog is created with `CREATE CATALOG`. To drop the base recovery catalog, execute `DROP CATALOG` while connected to the recovery catalog database as the recovery catalog owner.

#### Note:

When you drop the base recovery catalog, all RMAN metadata is removed from the recovery catalog. Any backups recorded in the recovery catalog but not in a target database control are not usable by RMAN.

When connected to a virtual private catalog, the `DROP CATALOG` command does *not* remove the base recovery catalog itself, but only drops the security policies that are used to restrict user access to the base catalog..

### Syntax

***dropCatalog::=***

```
→ DROP CATALOG [NOPROMPT] [;]
```

## Semantics

### NOPROMPT

Bypasses the confirmation step while dropping a catalog.

## 2.19 DROP DATABASE

### Purpose

Use the `DROP DATABASE` command to delete the target database and, if RMAN is connected to a recovery catalog, unregister it. RMAN removes the server parameter file, all data files, online redo logs, and control files belonging to the target database. By default, RMAN prompts for confirmation.



### Note:

This command cannot be used to delete a protected database that is configured to create backups to Zero Data Loss Recovery Appliance, commonly known as Recovery Appliance.

### Prerequisites

Execute this command only at the RMAN prompt. You must be connected to a target database. The target database must be mounted exclusive and not open, and started in `RESTRICT` mode.

### Syntax

***dropDatabase::=***



### Semantics

Syntax Element	Description
INCLUDING BACKUPS	Deletes backup sets, proxy copies, image copies, and archived redo log files associated with the target database from all configured device types. <b>Note:</b> If you use a recovery catalog but run RMAN in <code>NOCATALOG</code> mode when you drop the database, then RMAN does not delete any backups which are known to the recovery catalog but no longer exist in the target database control file.
NOPROMPT	Does not prompt for confirmation before deleting the database.

### Example

#### Example 2-83 Deleting a Database

In this example, you want to delete a test database called `test1` that is registered in the recovery catalog. You start the RMAN client, connect to database `test1` as `TARGET`, and



connect to the recovery catalog. You then run the following commands to delete the target database files, and all backups, copies, and archived redo log files associated with the database:

```
RMAN> CONNECT TARGET "sbu@test1 AS SYSBACKUP"

target database Password: password
connected to target database: TEST1 (DBID=39525561)

RMAN> STARTUP FORCE MOUNT
RMAN> ALTER SYSTEM ENABLE RESTRICTED SESSION;
RMAN> DROP DATABASE INCLUDING BACKUPS NOPROMPT;
```

## 2.20 DUPLICATE

### Purpose

Use the `DUPLICATE` command to create a copy of a **source database**. RMAN can create either of the following types of databases:

- A **duplicate database**, which is a copy of the source database (or a subset of the source database) with a unique DBID. Because a duplicate database has a unique DBID, it is independent of the source database and can be registered in the same recovery catalog. Typically, duplicate databases are used for testing.

You can duplicate the root, a whole CDB, or a PDB. Connect to the root as a user with the `SYSBACKUP` or `SYSDBA` privilege. When duplicating a PDB to a new CDB, the auxiliary instance must be a CDB.

Sparse databases can be duplicated using backup-based duplication in the target connection mode. To duplicate a sparse database, RMAN first performs an implicit restore and then picks the data files from the selected backup.

- A **standby database**, which is a special copy of the source database (called a **primary database** in a Data Guard environment) that is updated by applying redo data from the primary database. A standby database is not assigned a new DBID.

RMAN can perform the duplication in any of the following supported modes:

- **Active duplication**

RMAN duplicates the files directly from either an open or mounted database.

Active duplication can use image copies or backup sets. Backup sets offer several advantages, including unused block compression and encryption.

- **Backup-based duplication without a target connection**

RMAN creates duplicate files from pre-existing RMAN backups and copies. The `DUPLICATE` command must have been issued with the `DATABASE` clause. This form requires a connection to an auxiliary instance and a recovery catalog.

This mode is useful when the target database is not available or a connection to it is not desirable (as mandated by security policy restrictions or a firewall).

- **Backup-based duplication with a target connection**

RMAN creates duplicate files from pre-existing RMAN backups and copies.

- **Backup-based duplication without a connection to target or a recovery catalog**

RMAN creates duplicate files from RMAN backups and copies that were placed in a designated `BACKUP LOCATION`.

 **See Also:**

- *Oracle Database Backup and Recovery User's Guide* to learn how to create a duplicate database with the `DUPLICATE` command
- *Oracle Data Guard Concepts and Administration* to learn how to create, manage, and back up a standby database

**Additional Topics**

- [Prerequisites](#)
- [Usage Notes](#)
- [Syntax](#)
- [Semantics](#)
- [Examples](#)

**Prerequisites**

The prerequisites vary depending on the type of duplication.

 **See Also:**

For information about the versions supported for the RMAN client and auxiliary instance, see [RMAN Compatibility Matrix](#).

**Prerequisites Common to All Forms of Duplication**

RMAN must be connected as `AUXILIARY` to the instance of the duplicate database. The instance of the duplicate database is called the **auxiliary instance**. The auxiliary instance must be started with the `NOMOUNT` option.

The **source host** is the database on which the source database resides. The **destination host** is the host on which you intend to create the duplicate database. If you intend to create the duplicate database on the source host, then set the `CONTROL_FILES` initialization parameter appropriately so that the `DUPLICATE` command does not generate an error because the source control file is in use. Also, set all `*_DEST` or other related initialization parameters appropriately so that the source database files are not overwritten by the duplicate database files.

Typically, the source and duplicate databases must be on the same platform; however some cross-platform duplication is supported. For `DUPLICATE`, 32-bit and 64-bit versions of the same platform are considered the same platform. For example, Linux IA (32-bit) is considered the same platform as Linux IA (64-bit). However, after duplicating a database between 32-bit and 64-bit platforms, you must run the `utlirp.sql` script to convert the PL/SQL code to the new format. This script is located in `ORACLE_HOME/rdbms/admin` on Linux and UNIX platforms.

 **Note:**

In certain cases, the source and duplicate databases can be on different platforms. For more information about mixed platform support for the `DUPLICATE` command, refer to the My Oracle Support Note 1079563.1 at <https://support.oracle.com/rs?type=doc&id=1079563.1>

The `DUPLICATE` command requires one or more auxiliary channels. These channels perform the work of the duplication on the auxiliary database instance. In the following circumstances, RMAN uses the channel configuration from the source database for auxiliary channels:

- You have not used `ALLOCATE CHANNEL` to manually allocate auxiliary channels.
- You have not used `CONFIGURE` to configure auxiliary channels.

If you have configured automatic target channels to use `CONNECT` strings, then RMAN attempts to replicate the channel allocation on the auxiliary instance. However, if you must control or vary the channel allocation for duplication, you manually allocate auxiliary channels.

If the `COMPATIBLE` initialization parameter is set greater than or equal to 11.0.0, then by default RMAN duplicates transportable tablespaces that were not made read/write after being transported. Otherwise, RMAN cannot duplicate transportable tablespaces unless they have been made read/write after being transported.

To duplicate a CDB, the `COMPATIBLE` initialization parameter of the source CDB and the auxiliary instance must be 12.2.0 or higher. To duplicate a PDB to a new CDB, the `COMPATIBLE` initialization parameter of the source CDB and the auxiliary instance must be 12.2.0 or higher. To duplicate a PDB to an existing CDB, the `COMPATIBLE` initialization parameter of the source CDB and the destination CDB must be 18.0.0 or higher.

You must configure a static listener to perform duplication.

The following database encryption features use the Oracle software keystore: Transparent Data Encryption (TDE), which functions at the column level, and tablespace encryption. If you are duplicating an encrypted tablespace, then you must manually copy the Oracle keystore to the duplicate database. Auto-login keystores can be opened by RMAN when required. When a password-based Oracle keystore is used, the password required to open the Oracle keystore must be specified using the `SET DECRYPTION WALLET OPEN IDENTIFIED BY` command.

 **See Also:**

*Oracle Database Advanced Security Guide* to learn about TDE

### Prerequisites Specific to Backup-Based Duplication

As shown in [Table 2-6](#), the prerequisites for backup-based duplication depend on whether RMAN is connected as `TARGET` to the source database.

**Table 2-6 Prerequisites for Three Modes of Backup-Based Duplication**

Prerequisite	No Target and No Recovery Connection	No Target Connection	Target Connection
RMAN requires a connection to a recovery catalog.	No	Yes	No
All backups and archived redo log files used for creating and recovering the duplicate database must be accessible by the server session on the destination host.	Yes	Yes	Yes
If the destination host is different from the source host, then you must make backups on disk on the source host available to the destination host with the same full path name as in the source database.	No	Yes	Yes
You must provide the name of the source database with the <code>DATABASE</code> clause. If the name of the source database is not unique in the recovery catalog, then you must also provide the database ID (DBID) in the <code>DATABASE</code> clause.	No if <code>BACKUP LOCATION</code> does not have backups from multiple databases.	Yes	No
<code>UNTIL</code> clause must be specified in the current incarnation.	Not applicable	No	Yes
<code>NOREDO</code> must be specified when RMAN must prevent application of archived redo log files to the backups (see description of <code>NOREDO</code> for more information).	Yes	Yes	Yes
If you duplicate a subset of tablespaces, and if the source database is not open, then any duplicated tablespaces with undo segments must be listed in the <code>UNDO TABLESPACE</code> clause.	Yes	No	Yes (if no catalog used and target is not open)
RMAN automatically enforces the rule that the set of tablespaces must be self-contained and must not contain database objects owned by <code>SYS</code> .	No	No	Yes

### Prerequisites Specific to Active Database Duplication

When you execute `DUPLICATE` with `FROM ACTIVE DATABASE`, at least one normal target channel and at least one `AUXILIARY` channel are required. If you do not configure or preallocate channels, RMAN allocates the necessary channels by default. If you configure or manually allocate channels for active duplication with backup sets, ensure that the number of auxiliary channels is greater than or equal to the number of target channels.

When you connect RMAN to the source database as `TARGET`, you must specify a user name and password, even if RMAN uses operating system authentication. The connection to the auxiliary instance must use the same user name and password as the source database connection. The source database must be mounted or open. If the source database is open, then archiving must be enabled. If the source database is not open, then it must have been shut down consistently.

When you connect RMAN to the auxiliary instance, the following rules apply:

- When running RMAN on the same host as the auxiliary instance, you can connect locally without a net service name, provided that you connect using a user name and password, and provided that your `DUPLICATE` command does not include the `PASSWORD FILE` clause. The connecting user must have the `SYSDBA` or `SYSBACKUP` privilege.

- When connecting remotely, or when using the `PASSWORD FILE` clause in the `DUPLICATE` command, you must connect using a net service name. You must first create a password file for the auxiliary instance.

The source database and auxiliary instances must use the same `SYS` and `SYSBACKUP` password, which means that both instances must have password files. The password file must contain at least two passwords, for the `SYS` and `SYSBACKUP` users. You can start the auxiliary instance and enable the source database to connect to it.

The `DUPLICATE` behavior for password files varies depending on whether your duplicate database will act as a standby database. If you create a duplicate database that is not a standby database, then RMAN does not copy the password file by default. You can specify the `PASSWORD FILE` option to indicate that RMAN can overwrite the existing password file on the auxiliary instance. If you create a standby database, then RMAN copies the password file to the standby host by default, overwriting the existing password file. In this case, the `PASSWORD FILE` clause is not necessary.

You cannot use the `UNTIL` clause when performing active database duplication. RMAN chooses a time based on when the online data files have been completely copied, so that the data files can be recovered to a consistent point in time.



#### See Also:

*Oracle Database Security Guide* to learn about password protection

### Prerequisites for Duplicating a PDB to an Existing CDB

In addition to the prerequisites for active database duplication, the following prerequisites are applicable:

- The `COMPATIBLE` initialization parameter on the source CDB and the destination CDB must set to 18.0.0 or higher
- The source CDB and the auxiliary (duplicate) CDB must use local undo
- The PDB being duplicated must be in read-only or read-write mode
- The destination CDB to which the PDB is being duplicated must be open in read-write mode
- The destination CDB must use a server parameter file (spfile)
- The initialization parameter `REMOTE_RECOVERY_FILE_DEST` must be set on the destination CDB
- RMAN must connect to the root of the auxiliary (duplicate) CDB

### Prerequisites for Performing Duplication with Encryption

In addition to the prerequisites specific to the form of duplication being used, the following prerequisites are applicable when using the `AS ENCRYPTED` or `AS DECRYPTED` clauses.

- The `COMPATIBLE` initialization parameter must be set to 18.0.0 or higher
- The master key must be set at least once using the `ADMINISTER KEY MANAGEMENT SET ENCRYPTION KEY` command.

- Oracle keystore used to encrypt databases, CDBs, or tablespaces on the source database must be copied to the duplicate/auxiliary database and then opened.

### Usage Notes

When you duplicate a whole multitenant container database (CDB) or one or more pluggable databases (PDBs), you must create the auxiliary instance as a CDB and must connect to the root of both the target and auxiliary instances. To create the auxiliary instance as a CDB, include the declaration `enable_pluggable_database=TRUE` in the initialization parameter file.

Active database duplication with image copies uses the auxiliary net service name to copy the source database over the network to the auxiliary instance on the destination host. Conversely, in active database duplication with backup sets, the auxiliary instance uses the target instance net service name to retrieve the source database files over the network. Backup-based duplication uses pre-existing RMAN backups and copies.

Table 2-7 shows which files from the source database are duplicated.

**Table 2-7 Duplicated Files**

Source Database Files	Active Database	Backup-Based
Control files	Copied from source database when <code>FOR STANDBY</code> specified; otherwise re-created	Restored from backups
Data files	Copied from source database (unless excluded with a <code>SKIP</code> option)	Restored from backups (unless excluded with a <code>SKIP</code> option)
Tempfiles	Re-created (see " <a href="#">Temp File Re-Creation</a> ")	Re-created (see " <a href="#">Temp File Re-Creation</a> ")
Online redo log files	Re-created	Re-created
Standby redo log files	Re-created when <code>FOR STANDBY</code> specified and defined on primary database	Re-created when <code>FOR STANDBY</code> specified and defined on primary database
Archived redo log files	Copied from source database, but only if needed for the duplication	Obtained from backups or cataloged copies, but only if needed for the duplication
Server parameter file	Copied from source database (see <code>SPFILE</code> clause in <a href="#">dupOptionList</a> )	Restored from backup if <code>SPFILE</code> clause is specified (see <a href="#">dupOptionList</a> )
Flashback log files	Not re-created	Not re-created
Block change tracking file	Not re-created	Not re-created
Password file	Copied by default for standby databases; for nonstandby databases, copied only if <code>PASSWORD FILE</code> option is specified	Not re-created
Backups and other files in fast recovery area	Not copied	Not copied

All data files are included in the duplicate database unless they are offline clean or excluded. You can exclude tablespaces with the `SKIP` clause, or by including only a subset of tablespaces with `DUPLICATE ... TABLESPACE`.

The fast recovery area is defined on the duplicate or standby database if you explicitly define it. Also, if a fast recovery area was defined on the source database, and if the auxiliary instance uses a server parameter file that was copied or restored with the `DUPLICATE` command, then a fast recovery area is defined on the duplicate or standby database.

If you use active database duplication, then see the `FROM ACTIVE DATABASE` description in [dupOptionList](#) for usage notes.

### Backup-Based Duplication

In backup-based duplication of databases with a connection to the target database and in `NOARCHIVELOG` mode, media recovery uses the `NOREDO` option. Thus, if incremental backups exist, RMAN applies only these incremental backups to the restored files during recovery.

For backup-based duplication of databases in `ARCHIVELOG` mode, RMAN recovers by default up to the last archived redo log generated at the time the command was executed, or until a time specified with a `SET UNTIL` clause.

For backup-based duplication of databases without a connection to the target database, RMAN cannot determine whether the source database was in `NOARCHIVELOG` mode. Therefore, you must use the `NOREDO` option when the source database was in `NOARCHIVELOG` mode when the backups were taken. You can also use the `NOREDO` option when you do not want to apply archived redo log files to a consistent backup.

If you are using backup-based duplication, and if the source database and auxiliary instances reside on different hosts, then you must decide how to make the backups of the source database available to the auxiliary instance. For more information on how to do this with `BACKUP LOCATION`, review the options described in "*Oracle Database Backup and Recovery User's Guide*".

If the target database does not use a recovery area in ASM storage, then perform one of the following tasks before executing the `DUPLICATE` command:

- If you are using SBT backups, then make the tapes with the backups accessible to the destination host.
- If you are using disk backups, and if you can use the same backup directory names on the destination host as the source host, then do one of the following:
  - Manually transfer the backups and copies from the source host to the destination host to an identical path.
  - Use NFS or shared disks and ensure that the same path is accessible in the destination host.
- If you are using disk backups, and if you *cannot* use the same backup directory names on the destination host as the source host, then use of the techniques described in *Oracle Database Backup and Recovery User's Guide*.

If the source database uses a recovery area in ASM storage, then perform one of the following tasks before executing the `DUPLICATE` command:

- Make a database backup to a location outside the fast recovery area. You can make this backup accessible in the following ways:
  - Use NFS to mount the backup on the destination host with the same name.

- Use NFS to mount the backup on the destination host with a different name, and then `CATALOG` the backup while RMAN is connected as `TARGET` to the source database.
- Back up the fast recovery area to tape and use it for duplication.

### Duplication with Oracle Managed Files

If the source database files are in the Oracle Managed Files (OMF) format, then you cannot use the `DB_FILE_NAME_CONVERT` and `LOG_FILE_NAME_CONVERT` initialization parameters or the `fileNameConversionSpec` clause to generate new OMF file names for the duplicate database. If you do not follow this rule, the new OMF files generated from these three methods can cause problems. For more information on OMF names, see the "Considerations When Renaming OMF Auxiliary Set Files in TSPITR" in the *Oracle Database Backup and Recovery User's Guide*

The only exception to this rule is when changing only an ASM disk group name. Assume that source data files and online redo log files are stored in ASM disk group `+SOURCEFSK`. You want to store the duplicate database files in ASM disk group `+DUPFSK`. In this case, you can set the initialization parameters as follows:

```
DB_FILE_NAME_CONVERT = ("+SOURCEFSK", "+DUPFSK")
LOG_FILE_NAME_CONVERT = ("+SOURCEFSK", "+DUPFSK")
```

RMAN uses `DB_FILE_NAME_CONVERT` or `LOG_FILE_NAME_CONVERT` to convert the disk group name, and then generates a new, valid file name based on the converted disk group name.

You have the following other supported options for naming data files when the source files are in the Oracle Managed Files format:

- Use `SET NEWNAME` to specify names for individual data files.
- Set `DB_CREATE_FILE_DEST` to make all data files of the new database Oracle-managed files, except the files for which `SET NEWNAME` is used. Do not set `DB_FILE_NAME_CONVERT` if you set `DB_CREATE_FILE_DEST`.

Supported options for naming online redo logs duplicated from Oracle-managed files are `DB_CREATE_FILE_DEST`, `DB_RECOVERY_FILE_DEST`, or `DB_CREATE_ONLINE_LOG_DEST_n`.

### Temp File Re-Creation

The `DB_FILE_NAME_CONVERT` parameter can convert the temp file names for the new database that are not Oracle-managed files (OMF). The only exception to this restriction are Automatic Storage Management (ASM) OMF names where you can change only the name of the disk group.

The other method for converting temp file names for the new database is to use `SET NEWNAME FOR TEMPFILE TO 'filename'` or `TO NEW`. With this latter method, it does not matter if the data files are OMF or non-OMF, the temp files are re-created in the `DB_CREATE_FILE_DEST` directory location when the database is opened.

To specify different file names for the temp files, see the discussion of `SWITCH TEMPFILE`.

### Syntax

***duplicate::=***



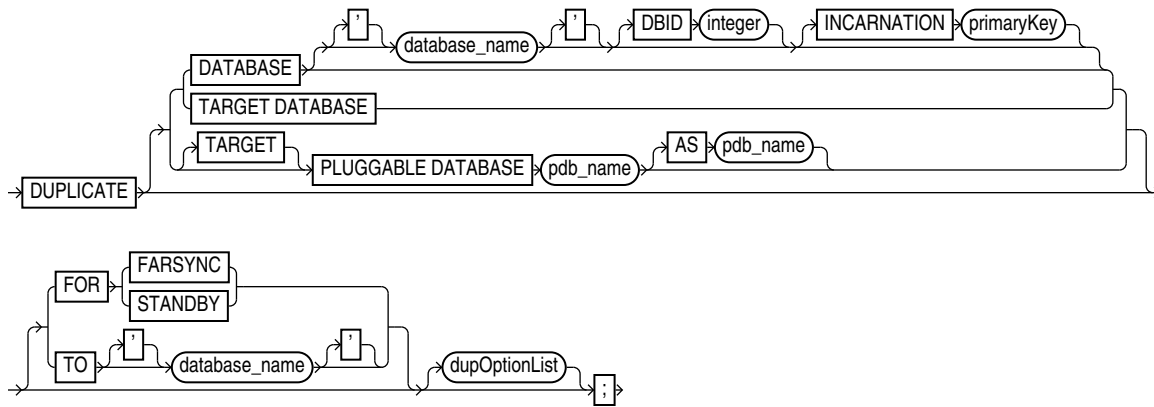

**(dupOptionList::=)**

**dupOptionList::=**

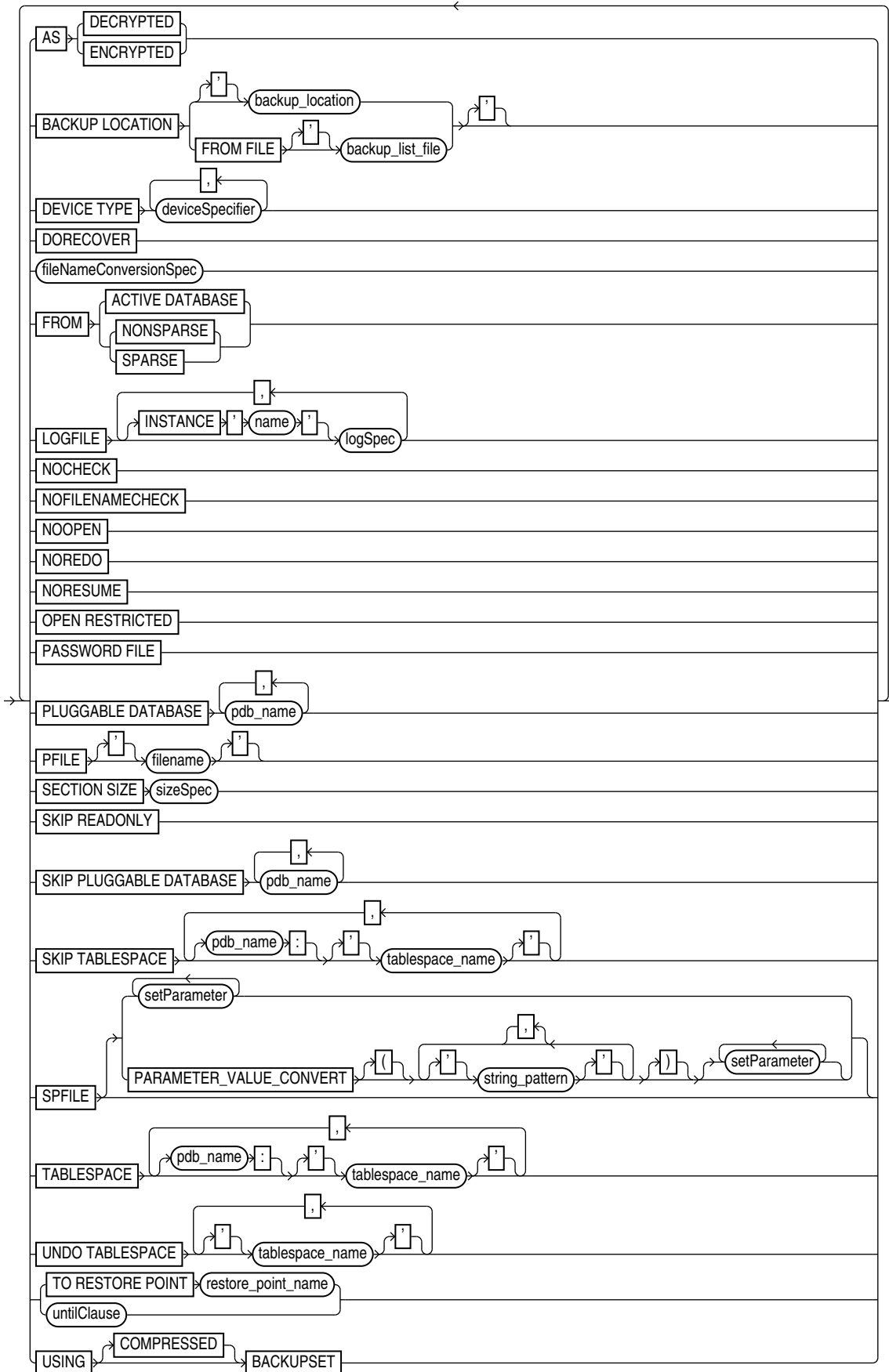

(deviceSpecifier::=, fileNameConversionSpec::=, logSpec::=, setParameter::=, sizeSpec::=, untilClause::=)

**setParameter::=**

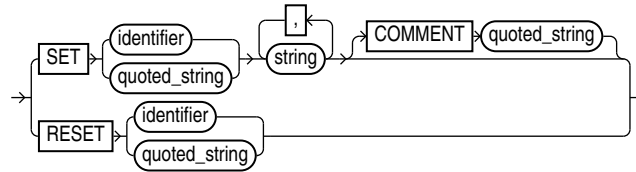

**logSpec::=**

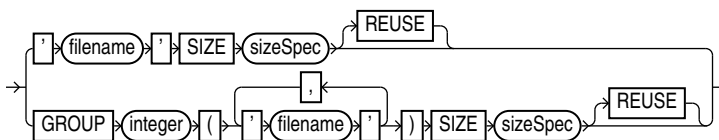

(sizeSpec::=)

**Semantics**

**duplicate**

This clause enables you to duplicate a database or tablespace. Refer to the [duplicate::=](#) diagram for the syntax.

Syntax Element	Description
TARGET DATABASE	Specifies the source database, which is the database you want to duplicate. Starting with Oracle Database 11g Release 2 the <code>TARGET</code> keyword is optional.
DATABASE	Specifies the source database. In a CDB, specifies the whole CDB. Specifies the PDB when connected to a PDB.
'database_name'	Specifies the name of the source database, which is the database to duplicate. This clause can be used instead of <code>TARGET DATABASE</code> when RMAN is connected as <code>TARGET</code> to the source database. When performing duplicate with a target connection, then you must specify the currently connected database and not use the <code>INCARNATION</code> subclause. For backup-based duplication without a target connection, you must either specify the database name or run the <code>SET DATABASE 'database_name'</code> command.
DBID integer	Specifies the database ID (DBID) of the source database. The <code>DBID</code> parameter is required when you duplicate without a <code>TARGET</code> connection to the source database and the database name in the recovery catalog is not unique. Another option is to use the <code>SET DBID</code> command. When RMAN duplicates the database while connected to the source database as <code>TARGET</code> , the <code>DBID</code> parameter is not needed. If you specify <code>DBID</code> , then set the value to match the <code>DBID</code> of the source database.

Syntax Element	Description
<code>INCARNATION primaryKey</code>	<p>Specifies an orphan incarnation.</p> <p>By default, the <code>DUPLICATE</code> command with the <code>UNTIL</code> clause refers to a point in time in the current database incarnation or the direct ancestor of the current incarnation. This clause enables you to designate an incarnation not in the current incarnation path, known as an orphan incarnation. It is invalid to specify <code>INCARNATION</code> when connected to a target database or when using <code>BACKUP LOCATION</code>.</p> <p>Another option is to use the <code>SET INCARNATION</code> command.</p>
<code>[TARGET] PLUGGABLE DATABASE pdb_name</code>	<p>Specifies the source PDB, which is the PDB that you want to duplicate to an existing CDB.</p> <p>You must connect to the root as a common user with the <code>SYSDBA</code> or <code>SYSBACKUP</code> privilege.</p> <p><b>Note:</b> Only active duplication is supported when using this option.</p>
<code>AS pdb_name</code>	<p>Specifies the name of the PDB in the destination CDB when duplicating a PDB to an existing CDB. If a PDB with the specified name exists in the destination CDB, then the command fails.</p>
<code>FOR FARSYNC</code>	<p>Creates an Oracle Data Guard far sync instance. You can use active database duplication or backup-based duplication to create a far sync instance.</p> <p>This option does not work with <code>DORECOVER</code> and results in an error message. See <i>Oracle Data Guard Concepts and Administration</i>.</p>
<code>FOR STANDBY</code>	<p>Designates the database being duplicated as a standby database (see <a href="#">Example 2-93</a>).</p> <p>To create a standby database with the <code>DUPLICATE</code> command you must specify the <code>FOR STANDBY</code> option. The <code>DUPLICATE ... FOR STANDBY</code> command creates the standby database by restoring a standby control file and mounting the standby control file. If you specify <code>FROM ACTIVE DATABASE</code>, then RMAN copies the data files from the primary to standby database. Otherwise, RMAN restores backups of the source database data files to the standby database. RMAN restores the most recent files, unless <code>SET UNTIL</code> is specified.</p> <p>If you are duplicating the SPFILE, then specify a unique <code>DB_UNIQUE_NAME</code> in the <code>SPFILE</code> clause. If not, then manually set this parameter to a unique value in the PFILE or SPFILE of the auxiliary instance.</p> <p>You cannot use <code>TO database_name</code> for a standby database.</p> <p>If you specify <code>DORECOVER</code>, then RMAN also recovers the database. The standby database remains mounted after duplication is complete.</p> <p>You cannot use <code>SET NEWNAME</code> or <code>CONFIGURE AUXNAME</code> to transform the file names for the online redo logs on the standby database.</p> <p>You cannot <code>CONNECT</code> RMAN to the standby database and then use <code>DUPLICATE ... FOR STANDBY</code> to create an additional standby database. To create additional standby databases, connect RMAN to the original primary database and run <code>DUPLICATE ... FOR STANDBY</code>.</p> <p><b>Note:</b> RMAN does not support partial PDB duplication. Therefore, you cannot use the <code>SKIP TABLESPACE</code>, <code>TABLESPACE</code>, <code>SKIP PLUGGABLE DATABASE</code>, and <code>PLUGGABLE DATABASE</code> options when creating a standby database.</p> <p><b>Note:</b> Although you can use the <code>DUPLICATE</code> command to create a standby database, you cannot use this command to activate a standby database.</p> <p>When you connect RMAN to the standby database and the recovery catalog in which the primary database is registered, RMAN recognizes the standby database and implicitly registers it. Do not attempt to use the <code>REGISTER</code> command for the standby database.</p>

Syntax Element	Description
<code>TO database_name</code>	<p>Specifies the name of the duplicate database when duplicating a CDB or PDB to a new CDB. This duplicate database is not a standby database, so this clause cannot be used with <code>FOR STANDBY</code>.</p> <p>Specifies the name of the CDB into which a source PDB must be duplicated when duplicating a PDB to an existing CDB. The CDB must exist and be opened in read-write mode.</p> <p>If you do not specify the <code>SPFILE</code> clause, then the specified database name must match the name in the initialization parameter file of the duplicate database instance, which is the instance to which RMAN is connected as <code>AUXILIARY</code>. Otherwise, the database signals an error.</p> <p>You cannot use the same database name for the source database and duplicate database when the duplicate database resides in the same Oracle home as the source database. However, if the duplicate database resides in a different Oracle home from the source database, then its database name just has to differ from other database names in its Oracle home. To simplify administration of duplicate database, Oracle recommends that you use different names for the source and duplicate databases.</p>
<code>dupOptionList</code>	<p>Specifies options for creating a duplicate or standby database. See <a href="#">dupOptionList</a>.</p>

### *dupOptionList*

This subclause includes options that control aspects of duplication such as naming the files and determining an end point for the duplication. Refer to the [dupOptionList::=](#) diagram for the syntax.

Specify new file names or convert source database file names for the data files and online redo logs when the file names of the duplicate database must be different from the file names of the source database (as when the destination host and source host are the same). If you do not specify file names for the online redo logs and data files of the duplicate database, then RMAN uses the data file names from the source database.

Syntax Element	Description
<code>AS ENCRYPTED</code>	<p>Specifies that data blocks must be encrypted at the destination database when duplicating a source CDB, PDBs, or tablespaces that are not encrypted.</p> <p>This is useful when you want to duplicate an on-premises database that does not use encryption to Oracle Cloud. Duplicating the database or PDB using <code>AS ENCRYPTED</code> ensures that the PDB on Oracle Cloud is encrypted.</p> <p><b>Note:</b> The <code>COMPATIBLE</code> initialization parameter must be set to 18.0.0 or higher to use this clause.</p> <p><b>Note:</b> You cannot use this clause with the <code>CONTROLFILE</code>, <code>SPFILE</code>, <code>ARCHIVELOG</code>, <code>FOREIGN ARCHIVELOG</code>, <code>DATAFILE</code>, <code>FOREIGN DATAFILE</code>, and <code>BACKUPSET</code> clauses.</p> <p><b>Note:</b> This clause is not supported for the following operations:</p> <ul style="list-style-type: none"> <li>• creating a standby database</li> <li>• duplicating a PDB to an existing CDB</li> <li>• performing point-in-time recovery</li> </ul>

Syntax Element	Description
AS DECRYPTED	<p>Specifies that a source database or PDB containing encrypted tablespaces or columns must be duplicated with the data blocks in the duplicate database being unencrypted.</p> <p><b>Note:</b> The <code>COMPATIBLE</code> initialization parameter must be set to 18.0.0 or higher to use this clause.</p> <p><b>Note:</b> You cannot use this clause with the <code>CONTROLFILE</code>, <code>SPFILE</code>, <code>ARCHIVELOG</code>, <code>FOREIGN ARCHIVELOG</code>, <code>DATAFILE</code>, <code>FOREIGN DATAFILE</code>, and <code>BACKUPSET</code> clauses.</p> <p><b>Note:</b> This clause is not supported for the following operations:</p> <ul style="list-style-type: none"> <li>• creating a standby database</li> <li>• duplicating a PDB to an existing CDB</li> <li>• performing point-in-time recovery</li> </ul>
BACKUP LOCATION <i>backup_location</i>	<p>Specifies the backup location on disk where the backups and copies of the database to be duplicated have been placed. This option is valid for duplication without a target or a recovery catalog connection.</p>
BACKUP LOCATION FROM FILE <i>backup_list_file</i>	<p>Specifies the name of the XML file that contains the backup metadata of the source database that you want to duplicate.</p> <p>Use this option if you are performing backup-based duplication of source database whose backups are stored in a non-disk location.</p> <p>For example, the source database backups, required for the duplication, may be stored in an Object Storage container on Oracle Cloud. In this case, you must first extract the source database backup metadata into an XML file, and then run the <code>DUPLICATE</code> command along with the <code>BACKUP LOCATION FROM FILE</code> clause. Indicate the location of the XML file using <code>backup_list_file</code>.</p> <p>For example, <code>BACKUP LOCATION FROM FILE '/home/oracle/OPC/duplicate.xml'</code>. See, <a href="#">Example 2-97</a></p> <p>You must ensure that the backup metadata file or the XML file is accessible to the destination host.</p>
DEVICE TYPE <i>deviceSpecifier</i>	<p>Allocates automatic channels for the specified device only (for example, <code>DISK</code> or <code>sbt</code>).</p> <p>This option is valid only if you have configured automatic channels and have <i>not</i> manually allocated channels. For example, if you <code>CONFIGURE</code> automatic disk and tape channels, and if you run <code>DUPLICATE...DEVICE TYPE DISK</code>, then RMAN allocates only disk channels.</p> <p><b>See Also:</b> <a href="#">deviceSpecifier</a></p>
DORECOVER	<p>Recovers the standby database after creating it. If you specify an <a href="#">untilClause</a>, then RMAN recovers to the specified SCN or time and leaves the database mounted.</p> <p>RMAN leaves the standby database mounted after media recovery is complete, but does not place the standby database in manual or managed recovery mode. After RMAN creates the standby database, you must resolve any gap sequence before placing it in manual or managed recovery mode, or opening it in read-only mode.</p> <p>The checkpoint SCN of the control file must be included in an archived redo log that is either available at the standby site or included in an RMAN backup. For example, assume that you create the standby control file and then immediately afterward archive the current log, which has a sequence of 100. In this case, you must recover the standby database up to at least log sequence 100, or the database signals an <code>ORA-1152</code> error message because the standby control file backup was taken after the point in time.</p>

Syntax Element	Description
<a href="#">fileNameConversionSpec</a>	<p>Specifies one or more patterns to map source database file names to duplicate database file names (see <a href="#">Example 2-87</a>).</p> <p><code>DB_FILE_NAME_CONVERT</code> set on the <code>DUPLICATE</code> command overrides the initialization parameter <code>DB_FILE_NAME_CONVERT</code> (if set). For example, if the initialization parameter file setting is <code>DB_FILE_NAME_CONVERT=('disk1', 'disk2')</code>, but you execute <code>DUPLICATE ... DB_FILE_NAME_CONVERT ('disk1', 'disk3')</code>, then RMAN does not convert the <code>disk1</code> substring to <code>disk2</code>. Instead, RMAN converts the <code>disk1</code> substring to <code>disk3</code>.</p> <p>If a file in the specification list is not affected by the conversion parameter in <code>DUPLICATE</code>, then you must rename it by other means, such as <code>SET NEWNAME</code>.</p> <p><b>Note:</b> If you specify the <a href="#">SPFILE</a> clause, then <code>DUPLICATE ... DB_FILE_NAME_CONVERT</code> overrides any conversion parameter specified in the <code>SPFILE</code> syntax. For example, if you specify <code>DB_FILE_NAME_CONVERT</code> twice in the <code>DUPLICATE</code> command, both in the <code>SPFILE</code> clause and outside of the <code>SPFILE</code> clause, then the setting outside of the <code>SPFILE</code> clause takes precedence.</p> <p><b>See Also:</b> <a href="#">fileNameConversionSpec</a></p>
FROM ACTIVE DATABASE	<p>Provides the files for the duplicate database directly from the source database and not from a backup of the source database (see <a href="#">Example 2-84</a>).</p> <p><b>See Also:</b> "<a href="#">Prerequisites Specific to Active Database Duplication</a>" for command prerequisites</p>
FROM SPARSE	<p>Provides the sparse data files for the duplicate database by internally restoring them from a sparse database. To use this setting, ensure that the <code>COMPATIBLE</code> initialization parameter of the database being duplicated is 12.2 or higher.</p>
FROM NONSPARSE	<p>Specifies that only non-sparse data files must be internally restored and then duplicated. This setting overrides the default sparseness mode of the duplication environment. To use this setting, ensure that the <code>COMPATIBLE</code> initialization parameter of the database being duplicated is 12.2 or higher. This setting does not affect the behavior of the other options of the <code>DUPLICATE</code> command.</p>
LOGFILE	<p>Specifies options for creating online redo logs when creating a duplicate database that is not a standby database (see <a href="#">Example 2-87</a>).</p>
INSTANCE 'inst_name'	<p>Creates online redo logs for the specified instance in a Real Applications Cluster (Oracle RAC) database. The instance name is a string of up to 80 characters.</p> <p>RMAN automatically uses the thread mapped to the specified instance. If no <code>INSTANCE</code> name is specified, then the log files are for the default instance.</p> <p>This clause is relevant when you use <code>DUPLICATE TARGET DATABASE</code> to duplicate an Oracle RAC database to a single-instance database. Otherwise, you do not need to use <code>INSTANCE</code>. If you use the <code>LOGFILE</code> clause, then use <code>INSTANCE</code> to specify the name of the Oracle RAC instance for each thread that was open during the database backup (for backup-based duplication) or during the <code>UNTIL TIME</code> (for active database duplication).</p>
<a href="#">logSpec</a>	<p>Specifies the file names and groups for the online redo log files.</p> <p><b>See Also:</b> <a href="#">logSpec</a> for the valid options</p>
NOCHECK	<p>Disables the RMAN ability to check that a set of tablespaces must be self-contained. This check is performed automatically by RMAN when backup based duplication with a target connection is performed.</p>

Syntax Element	Description
NOFILENAMECHECK	<p>Prevents RMAN from checking whether the data files and online redo logs files of the source database are in use when the source database files share the same names as the duplicate database files. You are responsible for determining that the duplicate operation does not overwrite useful data.</p> <p>This option is necessary when you are creating a duplicate database in a different host that has the same disk configuration, directory structure, and file names as the host of the source database. For example, assume that you have a small database located in the /dbs directory of srchost:</p> <pre>/oracle/dbs/system_prod1.dbf /oracle/dbs/users_prod1.dbf /oracle/dbs/rbs_prod1.dbf</pre> <p>Assume that you want to duplicate this database to desthost, which has the same file system /oracle/dbs/*, and you want to use the same file names in the duplicate database as in the source database. In this case, specify the NOFILENAMECHECK option to avoid an error message. Because RMAN is not aware of the different hosts, RMAN cannot determine automatically that it need not check the file names.</p> <p>If duplicating a database on the same host as the source database, then ensure that NOFILENAMECHECK is not set. Otherwise, RMAN can potentially overwrite and corrupt the target database data files, temp files, or online logs. It may also signal the following error:</p> <pre>RMAN-10035: exception raised in RPC: ORA-19504: failed to create file "/oracle/dbs/tbs_01.f" ORA-27086: skgfglk: unable to lock file - already in use SVR4 Error: 11: Resource temporarily unavailable Additional information: 8 RMAN-10031: ORA-19624 occurred during call to DBMS_BACKUP_RESTORE.RESTOREBACKUPPIECE</pre>
NOOPEN	<p>Specifies that the duplicate database must not be opened after it is created. By default, RMAN creates a duplicate database and then opens it in RESETLOGS mode.</p>
NOREDO	<p>Applies no archived redo log files when recovering a consistent backup in any of the following scenarios:</p> <ul style="list-style-type: none"> <li>You do not want to apply archived redo log files to the consistent backup even though the archived redo log files are available.</li> <li>The source database was running in NOARCHIVELOG mode at backup time and DUPLICATE is not connected to the target database.</li> <li>The source database is currently running in ARCHIVELOG mode but the backup was taken when the database was in NOARCHIVELOG mode.</li> </ul>
NORESUME	<p>Disables the ability for RMAN to automatically recover from a failed duplication operation. Using NORESUME in the first invocation of duplicate permanently prevents any subsequent duplicate command for the new database from using this automatic optimization.</p> <p><b>See Also:</b> <i>Oracle Database Backup and Recovery User's Guide</i> to learn more about the automated recovery from a failed DUPLICATE operation.</p>
OPEN RESTRICTED	<p>Enables a restricted session in the duplicate database by issuing the following SQL statement: ALTER SYSTEM ENABLE RESTRICTED SESSION. RMAN issues this statement immediately before the duplicate database is opened.</p>



Syntax Element	Description
PASSWORD FILE	<p>Uses the password file on the source database to overwrite the password file currently used by the auxiliary instance (see <a href="#">Example 2-84</a>). This option is only valid when <code>FROM ACTIVE DATABASE</code> is specified; otherwise, RMAN signals an error.</p> <p>If <code>FOR STANDBY</code> is specified, then RMAN copies the password file by default; if not specified, then RMAN does not copy the password file by default. You can use <code>PASSWORD FILE</code> to request that RMAN overwrite the existing password file with the password file from the source database. If you want the duplicate database to contain all the passwords available on your production database, then use the <code>PASSWORD FILE</code> option.</p>
PLUGGABLE DATABASE <i>pdb_name</i>	<p>Duplicates one or more PDBs specified in a comma-delimited list to a new CDB. To duplicate PDBs, you must connect to the root. To perform backup-based duplication of PDBs, you must also back up the root and the seed database (<code>PDB\$SEED</code>) of the CDB that contains the listed PDBs.</p> <p>By default, RMAN duplicates the <code>root</code> and the seed database of the CDB that contains the listed PDBs.</p> <p>See <i>Oracle Database Backup and Recovery User's Guide</i> for examples about duplicating PDBs.</p>
PFILE <i>filename</i>	<p>Specifies a text-based initialization parameter file used by the auxiliary instance (see <a href="#">Example 2-87</a>). RMAN automatically shuts down and restarts the auxiliary instance during duplication. If the auxiliary does not use a server parameter file in the default location, then you must specify the text-based initialization parameter file that RMAN uses when starting the auxiliary instance. The initialization parameter file must reside on the same host as the RMAN client used to perform the duplication.</p> <p>If the auxiliary instance uses a server parameter file in the default location, then you do not need to specify <code>PFILE</code>.</p>
SECTION SIZE <i>sizeSpec</i>	<p>Specifies the size of each backup section produced during the data transfer phase of the active duplicate operation. When this option is used, RMAN uses active duplication with backup sets by default. Therefore, ensure that prerequisites for this type of duplication are met.</p> <p>See <a href="#">SECTION SIZE <i>sizeSpec</i></a>.</p>
SKIP READONLY	<p>Excludes data files in current read-only tablespaces from the duplicate database. By default RMAN duplicates current read-only tablespaces.</p> <p>If a tablespace is currently read/write, but you use <a href="#">untilClause</a> to duplicate the database to an SCN at which the tablespace was read-only, then RMAN does not include the tablespace in the duplicate database. Tablespaces that were previously read-only are considered offline tablespaces and so are not included in the duplication.</p> <p><b>Note:</b> The read-only tablespaces must be self-contained for the <code>DUPLICATE</code> command to succeed with this option.</p>
SKIP PLUGGABLE DATABASE <i>pdb_name</i>	<p>Duplicates all the PDBs within the CDB, except the ones specified in the comma-separated list <i>pdb_name</i> to a new CDB. To duplicate PDBs, you must connect to the root.</p> <p>By default, RMAN duplicates the <code>root</code> and the seed database of the CDB.</p>

Syntax Element	Description
SKIP TABLESPACE <i>tablespace_name</i>	<p>Excludes the specified tablespace from the duplicate database (see <a href="#">Example 2-87</a>).</p> <p><b>Note:</b> This clause cannot be used when creating a standby database using <code>DUPLICATE ... FOR STANDBY</code>.</p> <p><b>Note:</b> You must not exclude <code>SYS</code>-owned objects or tablespaces with rollback segments, nor tablespaces containing materialized views. The set of tablespaces to be duplicated must be self-contained.</p> <p>If you must duplicate a database when some backups of the source database do not exist, then <code>SKIP TABLESPACE</code> is required. If you do not specify <code>SKIP TABLESPACE</code>, then RMAN attempts to duplicate the following:</p> <ul style="list-style-type: none"> <li>• All data files in online tablespaces, whether or not the data files are online.</li> <li>• All tablespaces taken offline with an option <i>other than</i> <code>NORMAL</code>. For example, RMAN attempts to duplicate tablespaces taken offline with the <code>IMMEDIATE</code> option. You cannot duplicate <code>OFFLINE NORMAL</code> tablespaces, although you can add these tablespaces manually after duplication.</li> </ul>
SKIP TABLESPACE <i>pdb-name:tablespace_name</i>	<p>Excludes the specified tablespaces from the duplicate PDB when duplicating a PDB to a new CDB. Multiple databases can have tablespaces with the same name, so a qualifier before the name uniquely identifies the tablespace. <i>pdb-name</i> is the name of a PDB.</p> <p>See the previous description of <code>SKIP TABLESPACE</code> for general information about excluding tablespaces from a duplicate database.</p> <p><b>Note:</b> You cannot use this clause with <code>CREATE PLUGGABLE DATABASE</code> to duplicate a PDB to an existing CDB.</p>
SPFILE  <a href="#">setParameter</a>	<p>Copies the server parameter file from the source database to the duplicate database. No initialization parameters previously set in the duplicate database are used.</p> <p>Sets the specified initialization parameters to the specified values. Refer to <a href="#">setParameter</a>.</p>
PARAMETER_VALUE_CONVERT RT <i>string_pattern</i> [ <a href="#">setParameter</a> ]	<p>Replaces the first string with the second string in all matching initialization parameter values. Refer to the description of <code>PARAMETER_VALUE_CONVERT</code> in <a href="#">dupOptionList</a>.</p>
TABLESPACE <i>tablespace_name</i>	<p>Specifies which tablespaces are included in the specified database.</p> <p>Unlike <code>SKIP TABLESPACE</code>, which specifies which tablespaces are <i>excluded</i> from the duplicate database, this option specifies which tablespaces are included and then skips the remaining tablespaces.</p> <p><b>Note:</b> RMAN automatically includes the <code>SYSTEM</code>, <code>SYSAUX</code>, and undo tablespaces in the duplicate database. These tablespaces cannot be skipped and the set of tablespaces that you want to duplicate must be self-contained.</p>
TABLESPACE <i>pdb-name:tablespace_name</i>	<p>Specifies which tablespaces are included in a CDB when duplicating a PDB to a new CDB. Multiple databases can have tablespaces with the same name. A qualifier before the name uniquely identifies the tablespace. <i>pdb-name</i> is the name of a PDB.</p> <p>See the previous descriptions of <code>TABLESPACE</code> and <code>UNDO TABLESPACE</code> for general information about these parameters.</p>

Syntax Element	Description
UNDO TABLESPACE <i>tablespace_name</i>	Specifies the names of the tablespaces with undo segments. This option is only required when a subset of tablespaces are being duplicated with the <code>SKIP TABLESPACE</code> and <code>TABLESPACE</code> clauses. You must provide the list of tablespaces with undo segments in the following cases: <ul style="list-style-type: none"> <li>No connection to the target database or the recovery catalog</li> <li>No connection to a recovery catalog, a connection to the target but the target database is not open.</li> </ul>
TO RESTORE POINT <i>restore_point_name</i>	Specifies a restore point for backup-based duplication, with the SCN at which the restore point was created as the upper, inclusive limit. Because the limit is inclusive, RMAN selects only files that it can use to duplicate a database up to <i>and including</i> the corresponding SCN. <b>Note:</b> The same restrictions that apply to <a href="#">untilClause</a> also apply to <code>TO RESTORE POINT</code> .
<a href="#">untilClause</a>	Sets the end time, SCN, or log sequence number for point-in-time recovery in backup-based duplication (see <a href="#">Example 2-87</a> ). The <code>UNTIL</code> clause is not supported in active database duplication. You can achieve the same result by running <code>SET UNTIL</code> before the <code>DUPLICATE</code> command. If you specify the <code>UNTIL</code> clause for duplication, then the following restrictions apply: <ul style="list-style-type: none"> <li>RMAN determines whether to use <code>NOREDO</code> based on the current state of the database. If the database was in an archiving mode at the specified <code>UNTIL</code> time or SCN that is different from the current archiving mode, then RMAN does not use <code>NOREDO</code>.</li> <li>The end point for a <code>DUPLICATE</code> command cannot be before the SCN of the most recent <code>ALTER DATABASE OPEN RESETLOGS</code>. Duplication with a connection to a target does not support previous database incarnations. However, you can specify previous incarnations if you are duplicating without a connection to a target database.</li> <li>You cannot recover the duplicate database to the current point in time, that is, the most recent SCN. RMAN recovers the duplicate database up to or before the most recent available archived log, but cannot recover into the online redo logs.</li> </ul>
USING BACKUPSET	Performs active database duplication by copying all or a subset of data from the source database to the destination database using backup sets.
USING COMPRESSED BACKUPSET	Enables binary compression of the data transfer from the source database to the auxiliary database, thereby reducing the network bandwidth consumption.

**setParameter**

This subclause specifies server parameter file values.

Syntax Element	Description
<code>SET identifier string</code>	<p>Sets the specified initialization parameters to the specified values (see <a href="#">Example 2-85</a>). You can use <code>SET</code> to adjust for differences in memory, turn off replication options, and set other options for the duplicate database.</p> <p>This <code>SET</code> functionality is equivalent to pausing the duplication after restoring the server parameter file and issuing <code>ALTER SYSTEM SET</code> statements to change the initialization parameter file.</p> <p>RMAN processes <code>SET</code> after <code>PARAMETER_VALUE_CONVERT</code>. If <code>PARAMETER_VALUE_CONVERT</code> sets the file name specified by a parameter, and if <code>SET</code> sets the file name specified by the same parameter, then the <code>SET</code> value overrides the <code>PARAMETER_VALUE_CONVERT</code> setting.</p> <p><b>Note:</b> If <code>DB_FILE_NAME_CONVERT</code> is specified on the <code>DUPLICATE</code> command, then its file name settings override competing settings specified by <code>SPFILE SET</code>.</p>
<code>COMMENT 'string'</code>	Specifies an optional comment for the parameter setting.
<code>RESET identifier string</code>	<p>Deletes specified initialization parameters from the parameter file. You can use <code>RESET</code> to remove unneeded initialization parameters.</p> <p>This <code>RESET</code> functionality is equivalent to pausing the duplication after restoring the server parameter file and issuing <code>ALTER SYSTEM RESET</code> statements to change the initialization parameter file.</p>

### logSpec

This subclause specifies the online redo logs when creating a duplicate database that is not a standby database. Refer to the [logSpec::=](#) diagram for the syntax diagram.

If you do not specify `LOGFILE`, then RMAN first checks whether any of the following initialization parameters are set: `LOG_FILE_NAME_CONVERT`, `DB_CREATE_FILE_DEST`, `DB_RECOVERY_FILE_DEST` or `DB_CREATE_ONLINE_LOG_DEST_n`. If these parameters are set, RMAN directs duplicate database online redo log files to Oracle managed storage based on these parameter settings. If none of these initialization parameters are set, then RMAN uses the original redo log file names of the source database for redo log files of the duplicate database. You must specify the `NOFILENAMECHECK` option in this case.

Syntax Element	Description
<code>'filename' SIZE sizeSpec</code>	Specifies the file name of the online redo log member and the size of the file in kilobytes (K) or megabytes (M). The default is in bytes.
<code>REUSE</code>	Allows the database to reuse an existing file. If the file exists, then the database verifies that its size matches the value of the <code>SIZE</code> parameter. If the file does not exist, then it is created.
<code>GROUP integer ('filename', ...)</code>	Specifies the group containing the online redo log members, the file name of the online redo log member, and the size of the file in kilobytes (K) or megabytes (M). The default is in bytes.
<code>SIZE sizeSpec</code>	The default is in bytes.
<code>REUSE</code>	Allows the database to reuse an existing log.

### Examples

#### Example 2-84 Duplicating from an Active Database to a Host with the Same Directory Structure

Assume that you want to create a test database from database `prod1` on a new host. The new host has the same directory structure as the source host, so the files in the duplicate

database can use the same names as the files in the source database. You want to create the database without using RMAN backups and allow `prod1` to remain open during the duplication.

If `prod1` uses a server parameter file, then you can create an initialization parameter file on the destination host that contains only the `DB_NAME` parameter set to a new value and the `DB_DOMAIN` parameter set to the appropriate domain. Setting `DB_DOMAIN` enables you to connect with RMAN to the default database service. Before starting the auxiliary instance, create a password file that has the same `SYS` and `SYSBACKUP` password as the source database. Afterward, start the auxiliary instance using an `spfile`, if available. If you start the auxiliary instance with a `pfile`, then RMAN creates an `spfile` in the default location, possibly overwriting any `spfile` residing there.

By default, RMAN does not duplicate the password file when creating a duplicate database that is not a standby database. The `PASSWORD FILE` option copies the password file to the destination host. If you want the duplicate database to contain all the passwords available on your source database, then use the `PASSWORD FILE` option.

You do not need to change your source database channel configuration or configure auxiliary channels. Start the RMAN client, connect to the source and auxiliary database instances with net service names, and duplicate the database as follows:

```
% rman
RMAN> CONNECT TARGET "sbu@prod1 AS SYSBACKUP"

target database Password: password
connected to target database: PROD1 (DBID=39525561)

RMAN> CONNECT AUXILIARY "sbu@dup1 AS SYSBACKUP"

auxiliary database Password: password
connected to auxiliary database: DUPL (not mounted)

RMAN> DUPLICATE TARGET DATABASE TO dup1
2> FROM ACTIVE DATABASE
3> NOFILENAMECHECK
4> PASSWORD FILE
5> SPFILE;
```

### Example 2-85 Copying the Server Parameter File in Active Database Duplication

Assume that you want to create a standby database from database `prod1` on a new host. The destination host has a different directory structure from the source host, so the standby database files are stored in `/disk2` rather than `/disk1`. You want to create the standby database without using RMAN backups and let `prod1` remain open during the duplication.

Your first step is to create a minimal initialization parameter file for the standby database and then start the standby instance. This parameter file is minimal because when you use the `SPFILE` option, RMAN copies the server parameter file to the new host and sets various parameters to the new values provided.

Start the RMAN client, `CONNECT` to the source database as `TARGET` and connect to the auxiliary instance. Allocate multiple channels to the target instance and a channel to the auxiliary instance as shown here:

```
ALLOCATE CHANNEL tgt10 TYPE DISK;
ALLOCATE CHANNEL tgt20 TYPE DISK;
```

```

ALLOCATE CHANNEL tgt30 TYPE DISK;
ALLOCATE CHANNEL tgt40 TYPE DISK;
ALLOCATE AUXILIARY CHANNEL dup1 TYPE DISK;

```

You can then enter the following command:

```

DUPLICATE TARGET DATABASE
  FOR STANDBY
  FROM ACTIVE DATABASE
  PASSWORD FILE
  SPFILE
  PARAMETER_VALUE_CONVERT '/disk1', '/disk2'
  SET DB_FILE_NAME_CONVERT '/disk1', '/disk2'
  SET LOG_FILE_NAME_CONVERT '/disk1', '/disk2'
  SET DB_UNIQUE_NAME 'dup1'
  SET SGA_MAX_SIZE 200M
  SET SGA_TARGET 125M;

```

### Example 2-86 Duplicating a Database Without a Target Connection to a Host with the Same Directory Structure

Assume that you want to duplicate source database `prod` using backups and do not want to connect RMAN as `TARGET` to this database because it is shut down for maintenance. A description of the environment follows:

- The source and destination hosts have identical directory structures. The data file and online redo log names in the duplicate database are identical to the names in the source database.
- The same number of online redo log files are used in the duplicate database.
- A recovery catalog is available. The source database name `prod` is unique in the recovery catalog.
- Auxiliary channels have been configured with the `CONFIGURE CHANNEL` command.

The following commands create a duplicate database named `DUPDB`:

```

% rman

RMAN> CONNECT CATALOG rco@catdb;

recovery catalog database Password: password
connected to recovery catalog database

RMAN> CONNECT AUXILIARY "sbu@dupdb AS SYSBACKUP";

auxiliary database Password: password
connected to auxiliary database: DUPDB (not mounted)

RMAN> DUPLICATE DATABASE 'PROD' TO 'DUPDB' NOFILENAMECHECK;

```

Assume a different scenario in which the database name `prod` is not unique in the recovery catalog. The following `DUPLICATE` command uses the `DBID` parameter to uniquely identify the source database:

```

RMAN> DUPLICATE DATABASE 'PROD' DBID 39525561 TO 'DUPDB' NOFILENAMECHECK;

```

### Example 2-87 Setting New File Names in the DUPLICATE Command

Assume that you want to use tape backups to duplicate the source database `prod` on `srchost` to `newdb` on `desthost`.

In this scenario, the source database does not use a server parameter file. You create a text-based initialization parameter file on `desthost` and use it to start the database instance. Thus, backup-based duplication must use a target connection (see [Table 2-6](#)).

When executing `DUPLICATE` on `desthost`, you must use the `PFILE` parameter to specify the location of the initialization parameter file. You must use the RMAN client on the same host as the initialization parameter file for the duplicate database.

You do not want the tablespaces `example` and `history` to be included in the duplicate database, so you specify `DUPLICATE ... SKIP TABLESPACE` for these tablespaces. Also, you want the duplicate database to be in the state that the production database was in 24 hours ago, so you use `DUPLICATE ... UNTIL TIME`.

This example assumes that the data files of the source database are on `srchost` in directory `/h1/oracle/dbs/trgt`. You intend to duplicate the data files to the directory `/h2/oracle/oradata/newdb`, so you specify `DUPLICATE ... DB_FILE_NAME_CONVERT` to generate the names for the duplicate data files. You use `DUPLICATE ... LOGFILE` to specify names for the online redo log files in the duplicate database.

Start the RMAN client on `desthost`, `CONNECT` to the source database as `TARGET`, and connect to the auxiliary instance. You can then enter the following `RUN` command:

```
RUN
{
  ALLOCATE AUXILIARY CHANNEL newdb DEVICE TYPE sbt;
  DUPLICATE TARGET DATABASE TO newdb
    PFILE ?/dbs/initNEWDB.ora
    UNTIL TIME 'SYSDATE-1' # specifies incomplete recovery
    SKIP TABLESPACE example, history # skip desired tablespaces
    DB_FILE_NAME_CONVERT ('/h1/oracle/dbs/trgt/', '/h2/oracle/oradata/newdb/')
    LOGFILE
      GROUP 1 ('/h2/oradata/newdb/redo01_1.f',
              '/h2/oradata/newdb/redo01_2.f') SIZE 4M,
      GROUP 2 ('/h2/oradata/newdb/redo02_1.f',
              '/h2/oradata/newdb/redo02_2.f') SIZE 4M,
      GROUP 3 ('/h2/oradata/newdb/redo03_1.f',
              '/h2/oradata/newdb/redo03_2.f') SIZE 4M REUSE;
}
```

### Example 2-88 Using SET NEWNAME FOR DATABASE to Name Duplicate Files

In this scenario, you intend to use backup-based duplication without a target connection.

The source database `prod` contains eight data files spread out over multiple directories. The data files are not Oracle Managed Files. You want to duplicate the source database to `dupdb` on destination host `desthost`.

In this scenario, `srchost` and `desthost` have different directory structures. You want to store the data files in `desthost` in the `/oradata1` subdirectory, so you use `SET NEWNAME FOR DATABASE` to specify the file names stripped of directory paths. For example, if a source data file has the name  `'/oradata/prod/financial.dbf'`, then `%b` results in `'financial.dbf'`.

The source database does not use a server parameter file, so you cannot use the `SPFILE` technique to specify names for the duplicate data files. You decide to use the

`SET NEWNAME DATABASE` command because you want all duplicate data files in the same directory on the destination host.

You want to create two online redo log groups, each with two members of size 200 KB, in the directory `/duplogs` on the destination host. Assume that `srchost` and `desthost` cannot mount each other's file systems by any means such as NFS.

You have disk copies or backup sets stored on disk for all the data files and archived redo log files in the source database, and you have manually copied them to `desthost` with an operating system utility. These backups and copies exist in the same location on `desthost` as they do in `srchost`.

You use an operating system utility to copy the initialization parameter file from `srchost` to an appropriate location in `desthost`. You have reset all initialization parameters that end in `_DEST` and specify a path name. You do not set `DB_FILE_NAME_CONVERT` and `LOG_FILE_NAME_CONVERT` because you are specifying names for data files and online logs in the `RUN` command itself. The auxiliary instance uses a server-side initialization parameter file in the default location so the `PFILE` parameter is not necessary on the `DUPLICATE` command.

The following sample script creates the duplicate database. A `RUN` command is necessary because you can only execute `SET NEWNAME` within `RUN`.

```
RUN
{
  SET NEWNAME FOR DATABASE TO '/oradata1/%b';
  DUPLICATE TARGET DATABASE TO dupdb
  LOGFILE
    GROUP 1 ('/duplogs/redo01a.log',
            '/duplogs/redo01b.log') SIZE 4M REUSE,
    GROUP 2 ('/duplogs/redo02a.log',
            '/duplogs/redo02b.log') SIZE 4M REUSE;
}
```

### Example 2-89 Using SET NEWNAME FOR DATAFILE and SET NEWNAME FOR TABLESPACE to Name Duplicate Files

In this scenario, you intend to duplicate database by using backup-based duplication.

Assume that the source database `PROD` is on `SRCHOST` and contains nine data files, which are spread out over multiple directories. You want to duplicate the source database to database `DUPDB` on remote host `DESTHOST`. The `DUPDB` database excludes tablespace `TOOLS`, but keeps all of the other tablespaces.

The source database does not use a server parameter file, so you cannot use the `SFILE` technique to specify names for the duplicate data files. You decide to use `SET NEWNAME` commands to specify the file names because the duplicate data files will be spread across several directories.

In this scenario, `srchost` and `desthost` have different directory structures. You want to store the data files in `desthost` in the `/oradata1` through `/oradata7` subdirectories. You want to place each data file in a different directory, except the `USERS` tablespace, which contains two data files that you intend to duplicate to `/oradata7`.

You want to create two online redo log groups, each with two members of size 200 KB, in the directory `/duplogs` on the destination host. Assume that `srchost` and `desthost` cannot mount each other's file systems by any means such as NFS.



You have disk copies or backup sets stored on disk for all the data files and archived redo log files in the source database, and you have manually copied them to `desthost` with an operating system utility. These backups and copies exist in the same location on `desthost` as they do in `srchost`.

You use an operating system utility to copy the initialization parameter file from `srchost` to an appropriate location in `desthost`. You have reset all initialization parameters that end in `_DEST` and specify a path name. You do not set `DB_FILE_NAME_CONVERT` and `LOG_FILE_NAME_CONVERT` because you are specifying names for data files and online logs in the `RUN` command itself. The auxiliary instance uses a server-side initialization parameter file in the default location so the `PFILE` parameter is not necessary on the `DUPLICATE` command.

The following sample scripts creates the duplicate database. A `RUN` command is necessary because you can only execute `SET NEWNAME` within `RUN`.

```
RUN
{
  SET NEWNAME FOR DATAFILE 1 TO '/oradata1/system01.dbf';
  SET NEWNAME FOR DATAFILE 2 TO '/oradata2/undotbs01.dbf';
  SET NEWNAME FOR DATAFILE 3 TO '/oradata3/cwmlite01.dbf';
  SET NEWNAME FOR DATAFILE 4 TO '/oradata4/drsys01';
  SET NEWNAME FOR DATAFILE 5 TO '/oradata5/example01.dbf';
  # because the users tablespace contains 2 data files, the following command
  # generates unique names for both data files, placing them in /oradata7
  SET NEWNAME FOR TABLESPACE users TO '/oradata7/users%b.dbf';
  DUPLICATE TARGET DATABASE TO dupdb
    SKIP TABLESPACE tools
    LOGFILE
      GROUP 1 ('/duplogs/redo01a.log',
              '/duplogs/redo01b.log') SIZE 4M REUSE,
      GROUP 2 ('/duplogs/redo02a.log',
              '/duplogs/redo02b.log') SIZE 4M REUSE;
}
```

### Example 2-90 Using SET NEWNAME FOR DATAFILE to Name Oracle-Managed Files

There are two ways to store specific data files or temp files in an Oracle-managed files destination that is independent of the locations of the rest of the database files.

1. Set the parameter `DB_CREATE_FILE_DEST` in the initialization parameter file of the auxiliary instance to the desired location
2. Set the initialization parameters `DB_CREATE_FILE_DEST` and `DB_FILE_NAME_CONVERT`. At this point, you can use the `SET NEWNAME` command for those data files that you do not want to be converted by `DB_FILE_NAME_CONVERT`.

The specified data files or temp files are created with Oracle-managed file names in the location specified by `DB_CREATE_FILE_DEST`.

As shown in the following sample script, you can also use `SET NEWNAME` to direct individual data files or temp files to a specific ASM disk group.

```
RUN
{
  SET NEWNAME FOR DATAFILE 1 TO "+DGROUP1";
  SET NEWNAME FOR DATAFILE 2 TO "+DGROUP2";
  .
  .
}
```

```

DUPLICATE TARGET DATABASE
  TO dupdb
  FROM ACTIVE DATABASE
  SPFILE SET DB_CREATE_FILE_DEST +DGROUP3;
}

```

### Example 2-91 Using CONFIGURE AUXNAME to Name Duplicate Files

This section assumes the same circumstances described in [Example 2-89](#). This example is a variation that uses `CONFIGURE AUXNAME` instead of `SET NEWNAME` to specify the new data file names. These new file names are recorded in the control file and used every time you perform the duplication in the future.

This example also uses automatic channels and a client-side initialization parameter file for the database duplication, and uses the `LOGFILE` clause to specify names and sizes for the online redo logs. In this case the `RUN` command is not necessary because you are not using `SET NEWNAME`.

```

CONFIGURE AUXNAME FOR DATAFILE 1 TO '/oradata1/system01.dbf';
CONFIGURE AUXNAME FOR DATAFILE 2 TO '/oradata2/undotbs01.dbf';
CONFIGURE AUXNAME FOR DATAFILE 3 TO '/oradata3/cwmlite01.dbf';
CONFIGURE AUXNAME FOR DATAFILE 4 TO '/oradata4/drsys01';
CONFIGURE AUXNAME FOR DATAFILE 5 TO '/oradata5/example01.dbf';
CONFIGURE AUXNAME FOR DATAFILE 6 TO '/oradata6/indx01.dbf';
DUPLICATE TARGET DATABASE
  TO dupdb
  SKIP TABLESPACE tools
  LOGFILE
    GROUP 1 ('/duplogs/redo01a.log',
            '/duplogs/redo01b.log') SIZE 4M REUSE,
    GROUP 2 ('/duplogs/redo02a.log',
            '/duplogs/redo02b.log') SIZE 4M REUSE;

```

RMAN uses all incremental backups, archived redo log backups, and archived redo log files to perform incomplete recovery and then opens the database with the `RESETLOGS` option to create the online redo logs.

After the duplication is complete, you can clear the configured auxiliary names for the data files in the duplicate database, so that they are not overwritten by future operations. For example, enter the following commands:

```

CONFIGURE AUXNAME FOR DATAFILE 1 CLEAR;
CONFIGURE AUXNAME FOR DATAFILE 2 CLEAR;
CONFIGURE AUXNAME FOR DATAFILE 3 CLEAR;
CONFIGURE AUXNAME FOR DATAFILE 4 CLEAR;
CONFIGURE AUXNAME FOR DATAFILE 5 CLEAR;
CONFIGURE AUXNAME FOR DATAFILE 6 CLEAR;

```

Alternatively, you may want to periodically synchronize a duplicate database with the original database that was duplicated. In this case, you can run the `DUPLICATE` command again, essentially re-creating the duplicate database. This technique requires making complete copies of the data files of the duplicate database. Run the following script whenever you want to synchronize the duplicate with the source database. For example, you might run the script daily or weekly.

```

DUPLICATE TARGET DATABASE TO dupdb
SKIP TABLESPACE tools
LOGFILE
  GROUP 1 ('/duplogs/redo01a.log',

```

```

        '/duplogs/redo01b.log') SIZE 4M REUSE,
GROUP 2 ('/duplogs/redo02a.log',
        '/duplogs/redo02b.log') SIZE 4M REUSE;

```

### Example 2-92 Creating a Standby Database with the Same Directory Structure

Assume that you want to use RMAN backups to create a standby database on a remote host with the same directory structure as the source host. The source database is called `prod1` and is the primary database in the Data Guard environment.

First, start the RMAN client, **CONNECT** to the source database `prod1` as `TARGET`, and connect to the auxiliary instance. You can then **CONFIGURE** the default device type to `sbt` for a standby database with the `DB_UNIQUE_NAME` of `standby1`:

```

CONFIGURE DEFAULT DEVICE TYPE sbt FOR DB_UNIQUE_NAME standby1;
CONFIGURE DEVICE TYPE sbt PARALLELISM 2 FOR DB_UNIQUE_NAME standby1;

```

Assume all backups needed to create the standby database are on tape. In the standby database initialization parameter file, you set `DB_UNIQUE_NAME` to `standby1`.

The default initialization parameter file location is in use on the standby database. After starting the standby instance `NOMOUNT`, you start the RMAN client, **CONNECT** to the source database as `TARGET`, and connect to the auxiliary instance and recovery catalog. You run the following **DUPLICATE** command, specifying the `NOFILENAMECHECK` option because the standby and primary data files and online redo log files have the same names:

```

DUPLICATE TARGET DATABASE FOR STANDBY
NOFILENAMECHECK;

```

### Example 2-93 Creating a Standby Database in OMF and ASM

Assume that you want to use RMAN backups to create a standby database on a host that uses OMF and ASM. The source database is called `prod1` and is the primary database in the Data Guard environment.

First, start the RMAN client, **CONNECT** to database `prod1` as `TARGET`, and connect to the recovery catalog. Run the following commands to **CONFIGURE** the default device type to `sbt` for a standby database with the `DB_UNIQUE_NAME` of `standby1` and the net service name `sby1`.

```

CONFIGURE CONNECT IDENTIFIER "sby1" FOR DB_UNIQUE_NAME standby1;
CONFIGURE DEFAULT DEVICE TYPE TO sbt FOR DB_UNIQUE_NAME standby1;
CONFIGURE DEVICE TYPE sbt PARALLELISM 2 FOR DB_UNIQUE_NAME standby1;

```

Assume all backups needed to create the standby database are stored on tape. You set the following parameters in the initialization parameter file for database `standby1`:

- Set `DB_UNIQUE_NAME` to the value `standby1`.
- Set `DB_CREATE_FILE_DEST` and `DB_RECOVERY_FILE_DEST` to the desired ASM disk groups on the standby host. For example, set `DB_CREATE_FILE_DEST` to `+DATAFILE` and `DB_RECOVERY_FILE_DEST` to `+FLASH_REC_AREA`.

Ensure that the standby instance is in `NOMOUNT` mode. Start the RMAN client, **CONNECT** to database `prod1` as `TARGET`, connect to the `standby1` instance as `AUXILIARY`, and connect to the recovery catalog. Enter the following command to create the standby database:

```

DUPLICATE TARGET DATABASE FOR STANDBY;

```

RMAN automatically generates new OMF/ASM data file names for the restored data files.

### Example 2-94 Duplicating a Database Without Connection to Target Database and Recovery Catalog

In this example, all the necessary backups of data files, control file and archived logs of database `prod` can be accessed from the location: `/net/prod/backups`. This location is where only backups of database `prod` reside. The only connection is to the new instance as `AUXILIARY`.

Enter the following command to create a test database when there is no connection to the recovery catalog or target database:

```
DUPLICATE DATABASE TO 'TEST' BACKUP LOCATION '/net/prod/backups' NOFILENAMECHECK;
```

### Example 2-95 Selecting a Specific Database When Duplicating Without Connection to Target Database and Recovery Catalog

In this example, `/backups` contains backups from several databases, including more than two databases with the name `PROD`. In this case, you must specify the `DBNAME` and the `DBID` of the database to duplicate. The only connection is to the auxiliary instance.

```
DUPLICATE DATABASE 'PROD' dbid 8675309 to 'TEST'
  UNTIL TIME "to_date('11/01/2013', 'MM/DD/YYYY')"
  BACKUP LOCATION '/backups' NOFILENAMECHECK
  PFILE='?/dbs/inittest.ora' db_file_name_convert='prod','test';
```

### Example 2-96 Duplicating PDBs and Specific Tablespaces in a PDB to a New CDB

In this example, the PDBs `pdb1`, `pdb5`, and the `users` tablespace in PDB `pdb2` are duplicated to a new CDB. By default, RMAN also duplicates the `root` and the `seed` database in the CDB. The auxiliary instance must have been started with an initialization parameter file that contains the declaration `enable_pluggable_database=TRUE`. You are connected to the `root` as a user with the common `SYSBACKUP` privilege.

```
DUPLICATE TARGET DATABASE TO cdb
  PLUGGABLE DATABASE pdb1,pdb5
  TABLESPACE pdb2:users;
```

### Example 2-97 Duplicating an On-premise Database Using Its Cloud Backup and Without a Connection to the Target Database and Recovery Catalog

This example assumes the source database backups are stored in Oracle Cloud. The backup metadata, required for the duplication, is stored in an XML file called `duplicate.xml` in the location `/dsk1/bkps` on the destination database.

This is a sample content of an XML file.

```
<MetaData>
  <File>
    <Filename>6GJ28IEKFL_07CEC18D372F4D29E06379624664E053</Filename>
    <SetStamp>1150345378</SetStamp>
    <IsSpfile>NO</IsSpfile>
    <IsControlFile>NO</IsControlFile>
    <PieceNo>1</PieceNo>
    <Dbname>SALESDB</Dbname>
    <Dbid>3483424530</Dbid>
  </File>
</File>
```

```

        <Filename>6GJ28IEKFL_07CEC1A6254D4D36E0637962466444CD</Filename>
        <SetStamp>1150345451</SetStamp>
        <IsSpfile>NO</IsSpfile>
        <IsControlFile>NO</IsControlFile>
        <PieceNo>1</PieceNo>
        <Dbname>SALESDB</Dbname>
        <Dbid>3483424530</Dbid>
    </File>
</MetaData>

```

Run the `DUPLICATE` command along with the `BACKUP LOCATION FROM FILE` clause to specify the location of the backup metadata file `duplicate.xml`.

```

RMAN>
RUN {
ALLOCATE AUXILIARY CHANNEL ch1 DEVICE TYPE SBT PARMS 'SBT_LIBRARY=/
home/oracle/OPC/lib/libopc.so,
ENV=(OPC_PFILE=/home/oracle/OPC/opcConfig.ora)';
SET NEWNAME FOR DATABASE TO '/u01/app/oracle/oradata/DUP122/%b';
DUPLICATE DATABASE SALESDB to DUPSLESDB
LOGFILE
GROUP 1 ('/u01/app/oracle/oradata/DB122/redo01.log') size 100M reuse,
GROUP 2 ('/u01/app/oracle/oradata/DB122/redo02.log') size 100M reuse
BACKUP LOCATION FROM FILE '/dsk1/bkps/duplicate.xml';

```

## 2.21 EXECUTE SCRIPT

### Purpose

Use the `EXECUTE SCRIPT` command to run a local or global RMAN script stored in the recovery catalog.



#### See Also:

- *Oracle Database Backup and Recovery User's Guide* to learn how to use stored scripts
- [CREATE SCRIPT](#) and [REPLACE SCRIPT](#)

### Prerequisites

Use `EXECUTE SCRIPT` only within the braces of a `RUN` command. RMAN must be connected to the recovery catalog with the `CATALOG` command-line option or the `CONNECT CATALOG` command. The recovery catalog database must be open.

### Usage Notes

When you run an `EXECUTE SCRIPT` command within a `RUN` block, RMAN places the contents of the script in that `RUN` block. Therefore, do not allocate a channel within the `RUN` block if you also allocate it in the script.

If `GLOBAL` is specified, then a global script with this name must exist in the recovery catalog; otherwise, RMAN returns error `RMAN-06004`. If `GLOBAL` is not specified, then RMAN searches for a local stored script defined for the current target database. If no local script with this name is found, then RMAN searches for a global script by the same name and executes it if one is found.

## Syntax

**`executeScript::=`**

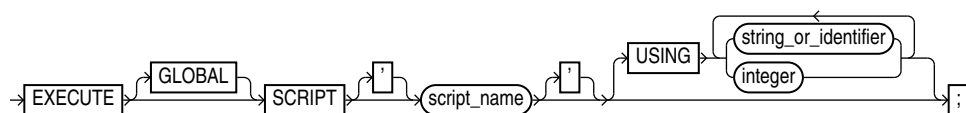

## Semantics

Syntax Element	Description
GLOBAL	Specifies the execution of a global stored script instead of a local one. <b>See Also:</b> "Usage Notes" for an explanation of the difference between global and local scripts
SCRIPT <i>script_name</i>	Specifies the name of the stored script to execute. Quotes must be used around the script name when the name contains either spaces or reserved words.
USING [ <i>string_or_identifier</i>   <i>integer</i> ]	Specifies one or more values for use in substitution variables in a stored script (see <a href="#">Example 2-99</a> ). <b>See Also:</b> <a href="#">CREATE SCRIPT</a> to learn how to create a stored script with substitution variables, and <a href="#">RMAN</a> and <a href="#">@ (at sign)</a> to learn how to use substitution variables with RMAN

## Example

### Example 2-98 Executing a Stored Script

This example uses `LIST` to list the script stored in the recovery catalog and `PRINT SCRIPT` to show the contents of `global_backup_db`, which was created in [Example 2-74](#). Finally, the example runs `global_backup_db` to back up the database.

```
RMAN> LIST SCRIPT NAMES;
```

```
List of Stored Scripts in Recovery Catalog
```

```
Global Scripts
```

```
Script Name
Description
-----
```

```
global_backup_db
back up any database from the recovery catalog, with logs
```

```
RMAN> PRINT SCRIPT global_backup_db;
```

```
printing stored global script: global_backup_db
{
  BACKUP DATABASE PLUS ARCHIVELOG;
}
```

```
RMAN> RUN { EXECUTE GLOBAL SCRIPT global_backup_db; }

executing global script: global_backup_db

Starting backup at 07-JUN-13
current log archived
allocated channel: ORA_DISK_1
channel ORA_DISK_1: SID=120 device type=DISK
.
.
.
```

### Example 2-99 Creating and Executing a Stored Script That Uses Substitution Variables

After starting RMAN and connecting to a target database and recovery catalog, use [REPLACE SCRIPT](#) to create a backup script that includes three substitution variables. RMAN prompts you to enter initial values for the variables (user input is in bold).

```
RMAN> REPLACE SCRIPT
2> backup_df { BACKUP DATAFILE &1 TAG &2.1 FORMAT '/disk1/&3_%U'; }
  Enter value for 1: 1

Enter value for 2: df1_backup

Enter value for 3: df1

starting full resync of recovery catalog
full resync complete
created script backup_df
```

Later, you can execute the `backup_df` script with different values. The following example passes the values `3`, `test_backup`, and `test` to the substitution variables in the stored script:

```
RMAN> RUN { EXECUTE SCRIPT backup_df USING 3 test_backup df3; }
```

After the values are substituted, RMAN executes the `BACKUP` command as follows:

```
BACKUP DATAFILE 3 TAG test_backup1 FORMAT '/disk1/df3_%U';
```

## 2.22 EXIT

### Purpose

Use the `EXIT` command to shut down the Recovery Manager utility. This command is functionally equivalent to the [QUIT](#) command.

### Prerequisites

Execute only at the RMAN prompt.

### Syntax

**exit::=**



### Example

#### Example 2-100 Exiting RMAN

This example terminates RMAN:

```
RMAN> EXIT
```

## 2.23 FLASHBACK DATABASE

### Purpose

Use the `FLASHBACK DATABASE` command to rewind the database to a target time, SCN, log sequence number, or restore point.

This command undoes changes made by Oracle Database to the data files that exist when you run the command. Flashback can fix logical failures, but not physical failures. As a result, you cannot use the command to recover from disk failures or the accidental deletion of data files.

`FLASHBACK DATABASE` is usually much faster than a `RESTORE` operation followed by point-in-time recovery because no data files are restored. The time needed to perform `FLASHBACK DATABASE` depends on the number of changes made to the database since the desired flashback time. On the other hand, the time needed to do a traditional point-in-time recovery from restored backups depends on the size of the database.

Flashback Database operations also have several uses in a Data Guard environment.

#### Note:

Flashback operations on a proxy PDB are not supported.

#### See Also:

- *Oracle Database SQL Language Reference* for a complete list of command prerequisites and usage notes for `FLASHBACK DATABASE`
- *Oracle Data Guard Concepts and Administration* to learn about uses of Flashback Database in a Data Guard environment

### Prerequisites

- You can run this command from the RMAN prompt or from within a `RUN` command.
- RMAN must be connected as `TARGET` to a database, which must be Oracle Database 10g or later. The target database must be mounted with a current control file, that is, the control file cannot be a backup or re-created.
- The database must run in `ARCHIVELOG` mode.



- The fast recovery area must be configured to enable flashback logging.  
Flashback logs are stored as Oracle-managed files in the fast recovery area and cannot be created if no fast recovery area is configured.
- You must enable flashback logging before the target time for flashback by issuing the SQL statement `ALTER DATABASE ... FLASHBACK ON`.  
Query `V$DATABASE.FLASHBACK_ON` to see whether flashback logging has been enabled.
- You cannot use `FLASHBACK DATABASE` to return to a point in time before the restore or re-creation of a control file. If the database control file is restored from backup or re-created, then all existing flashback log information is discarded.
- The database must contain no online tablespaces for which flashback functionality was disabled with the SQL statement `ALTER TABLESPACE ... FLASHBACK OFF`.

### Prerequisites for Flashback Operations on PDBs

The following are additional prerequisites for performing flashback operations on a pluggable database (PDB):

- The `COMPATIBLE` initialization parameter must be set to 12.2.0.0 or higher.
- RMAN must be connected to the root as a common user with the `SYSDBA` or `SYSBACKUP` privilege.
- The PDB on which a Flashback Database operation is being performed must be closed. Other PDBs may be open and operational.
- The root must be open when opening the PDB with `resetlogs`.

### Usage Notes

A Flashback Database operation applies to the whole database. You cannot flash back individual tablespaces. A Flashback Database operation is similar to a database point-in-time recovery (DBPITR) performed with `RECOVER`, but RMAN uses **flashback logs** to undo changes to a point before the target time or SCN. RMAN automatically restores from backup any archived redo log files that are needed and recovers the database to make it consistent. RMAN never flashes back data for temporary tablespaces.

The earliest SCN that can be used for a Flashback Database operation depends on the setting of the `DB_FLASHBACK_RETENTION_TARGET` initialization parameter, and on the actual retention of flashback logs permitted by available disk. View the current database SCN in `V$DATABASE.CURRENT_SCN`.

In a multitenant environment, you can perform a flashback database operation either for the whole CDB or for a particular PDB. When using restore points, you can rewind the PDB either to a PDB restore point or CDB restore point.

 **See Also:**

- “Overview of Restore Points in a Multitenant Environment” in *Oracle Database Backup and Recovery User's Guide* for information about PDB restore points and CDB restore points
- “Performing Point-in-Time Recovery of CDBs and PDBs” in *Oracle Database Backup and Recovery User's Guide* for the steps to rewind a PDB to a specific point in time

**Effect of NOLOGGING Operations on Flashback Database**

When using `FLASHBACK DATABASE` with a target time at which a `NOLOGGING` operation was in progress, block corruption is likely in the database objects and data files affected by the `NOLOGGING` operation. For example, assume that you do a direct-path `INSERT` operation in `NOLOGGING` mode and that the operation runs from 9:00 to 9:15 on April 3. If you later use Flashback Database to return to 09:07 on this date, then the objects and data files updated by the direct-path `INSERT` may be left with block corruption after Flashback Database completes.

If possible, avoid using `FLASHBACK DATABASE` with a target time or SCN that coincides with a `NOLOGGING` operation. Also, perform a full or incremental backup of the affected data files immediately after any `NOLOGGING` operation to ensure recoverability to points in time after the operation. If you expect to use `FLASHBACK DATABASE` to return to a point in time during an operation such as a direct-path `INSERT`, then consider performing the operation in `LOGGING` mode.

 **See Also:**

The discussion of `logging_clause` in *Oracle Database SQL Language Reference* for more information about operations that support `NOLOGGING` mode

**Effect of Data File Status Changes on Flashback Database**

The `FLASHBACK DATABASE` command does not start modifying the database until it has made sure that it has all the files and resources that it needs. A Flashback Database operation does not fail due to missing data files, redo log files, or flashback logs.

If a data file has changed status between the current SCN and the target SCN of the flashback, then the `FLASHBACK DATABASE` command behaves differently depending on the nature of the status change. Refer to [Table 2-8](#) for details.

**Table 2-8 How FLASHBACK DATABASE Responds to Data File Status Changes**

If this data file operation occurred during the flashback window ...	Then the FLASHBACK DATABASE command ...
Added	Removes the data file record from the control file.

Table 2-8 (Cont.) How FLASHBACK DATABASE Responds to Data File Status Changes

If this data file operation occurred during the flashback window ...	Then the FLASHBACK DATABASE command ...
Dropped	Adds the data file to the control file, but marks it as offline and does not flash it back. You can then restore and recover the data file to the same time or SCN.
Renamed	Ignores the renaming. The data file retains its current name.
Resized	May fail. You can take the data file offline and then rerun the FLASHBACK DATABASE command. The data file is not flashed back. You can then restore and recover the data file to the same time or SCN.
Taken offline	Ignores the operation. The data file retains its current online status.
Brought online	Ignores the operation. The data file retains its current offline status.
Made read-only or read/write	Changes the status of the data file in the control file.

### Tablespaces with Flashback Logging Disabled

It is possible for the `ALTER TABLESPACE ... FLASHBACK OFF` statement to have been executed for some tablespaces. If `FLASHBACK DATABASE` has insufficient flashback data to rewind a tablespace to the target SCN, then `RMAN` issues an error and does not modify the database. Whenever `FLASHBACK DATABASE` fails or is interrupted, the database is left mounted.

In this scenario, query `V$TABLESPACE` to determine which tablespaces have flashback logging disabled. You have the following options:

- Take the data files in the affected tablespaces offline. Afterwards, run `RESTORE` and then `RECOVER` to bring these data files to the same point in time as the rest of the database.
- Drop the affected data files with the `ALTER DATABASE DATAFILE ... OFFLINE FOR DROP` statement. You can then open the database with the `RESETLOGS` option. After the database is open, execute `DROP TABLESPACE` statements for the tablespaces that contain the dropped data files.

### State of the Database After Flashback Database

After running `FLASHBACK DATABASE`, the database may not be left at the SCN most immediately before the target time. Events other than transactions can cause the database SCN to be updated. If you use the `FLASHBACK DATABASE TO` form of the command, and if a transaction is associated with the target SCN, then after the flashback the database includes all changes up to and including this transaction. Otherwise, all changes up to but *not* including this transaction are included in the data files, whether you use the `FLASHBACK DATABASE TO` or `FLASHBACK DATABASE TO BEFORE` form of the command. Changes after the specified target SCN are never applied because of `FLASHBACK DATABASE`.

After `FLASHBACK DATABASE` completes, you may want to open the database read-only and run queries to ensure that you achieved the intended result. If you are not satisfied, then you can use `RECOVER DATABASE` to recover the database to its state when you started the flashback. You can then rerun `FLASHBACK DATABASE`.

If you are satisfied with the results of the flashback, then you can `OPEN RESETLOGS` to abandon all changes after the target time. Alternatively, you can use Data Pump to

export lost data, use `RECOVER DATABASE` to return the database to its state before the flashback operation, and then use Data Pump to reimport the lost data.

### Syntax

**flashback::=**

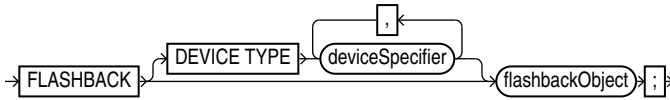

**flashbackObject::=**

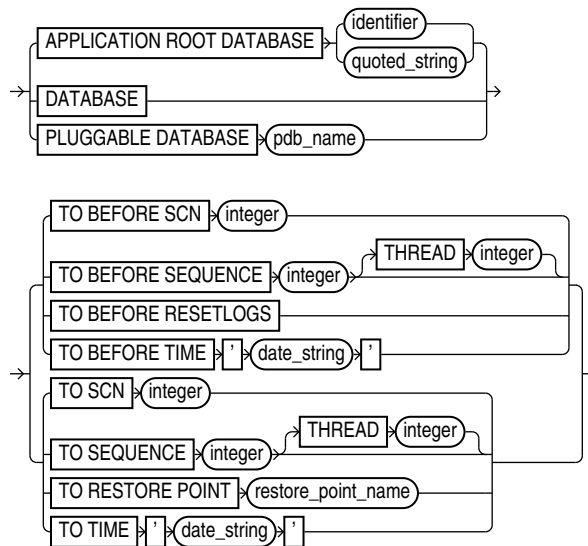

(**deviceSpecifier::=**)

### Semantics

**flashback::=**

Syntax Element	Description
DEVICE TYPE <a href="#">deviceSpecifier</a>	Allocates automatic channels for the specified device type only. For example, if you configure automatic disk and tape channels, and issue <code>FLASHBACK . . . DEVICE TYPE DISK</code> , then RMAN allocates only disk channels. RMAN may need to restore redo logs from backup during the flashback database process. Changes between the last flashback log and the target time must be re-created based on the archived redo log. If no automatic channels are allocated for tape and a needed redo log is on tape, then the <code>FLASHBACK DATABASE</code> operation fails. <b>See Also:</b> <a href="#">deviceSpecifier</a>

**flashbackObject::=**

Syntax Element	Description
DATABASE	Rewinds the entire CDB, including the root and all PDBs.
PLUGGABLE DATABASE <i>pdb_name</i>	Rewinds the specified PDB. All other PDBs can be open and operational, but the specified PDB must be closed.  When the CDB uses shared undo, an auxiliary destination is used to store temporary files used during the flashback operation. The default auxiliary destination is the fast recovery area. You can use the <code>AUXILIARY DESTINATION</code> clause to explicitly specify an alternate auxiliary destination that is not the fast recovery area.
TO BEFORE SCN <i>integer</i>	Returns the database to its state just before the specified SCN. Any changes at an SCN lower than that specified are applied, but if there is a change associated with the specified SCN it is not applied. By default, the provided SCN resolves to the current or ancestor incarnation. You can override the default by using the <code>RESET DATABASE INCARNATION</code> command.  Query <code>OLDEST_FLASHBACK_SCN</code> in <code>V\$FLASHBACK_DATABASE_LOG</code> to see the approximate lowest SCN to which you can flash back.
TO BEFORE SEQUENCE <i>integer</i> [ <code>THREAD integer</code> ]	Specifies a redo log sequence number and thread as an upper limit. RMAN applies changes up to (but not including) the last change in the log with the specified sequence and thread number.
TO BEFORE RESETLOGS	Returns the database to its state including all changes up to the SCN of the most recent <code>OPEN RESETLOGS</code> .  <b>Note:</b> <code>FLASHBACK DATABASE</code> can only return the database to a point before the most recent <code>OPEN RESETLOGS</code> operation if your database has been upgraded to Oracle Database 10g Release 2 or later.  For PDBs, the Flashback Operation must return the PDB to its state including all changes up to the most recent <code>OPEN RESETLOGS</code> operation on the CDB or the most recent <code>OPEN RESETLOGS</code> operation on the PDB, whichever of the two is more recent.
TO BEFORE TIME ' <i>date_string</i> '	Returns the database to its state including all changes up to but not including changes at the specified time.  Query <code>OLDEST_FLASHBACK_TIME</code> in <code>V\$FLASHBACK_DATABASE_LOG</code> to see the approximate lowest time to which you can flash back.
TO SCN <i>integer</i>	Returns the database to the point up to (and including) the specified SCN. By default, the provided SCN resolves to the current or ancestor incarnation. You can override the default by using the RMAN <code>RESET DATABASE</code> command to set the recovery target incarnation.  Query <code>OLDEST_FLASHBACK_SCN</code> in <code>V\$FLASHBACK_DATABASE_LOG</code> to see the approximate lowest SCN to which you can flash back.
TO SEQUENCE <i>integer</i> THREAD <i>integer</i>	Specifies a redo log sequence number and thread as an upper limit. RMAN applies changes up to (and including) the last change in the log with the specified sequence and thread number.
TO RESTORE POINT <i>restore_point_name</i>	Returns the database to the SCN associated with the specified restore point. This can be an ordinary restore point or a guaranteed restore point.  For CDBs, you must specify a CDB restore point. The entire CDB is returned to the SCN associated with the specified CDB restore point.  For PDBs, you can specify either a CDB restore point, PDB restore point, or a clean PDB restore point. RMAN returns the PDB to the SCN associated with the specified restore point. The remaining PDBs in the CDB are not impacted by a flashback operation on a particular PDB.

Syntax Element	Description
TO TIME 'date_string'	Returns the database to its state at the specified time. You can use any SQL DATE expressions to convert the time to the current format, for example, FLASHBACK DATABASE TO TIME 'SYSDATE-7'.  Query OLDEST_FLASHBACK_TIME in V\$FLASHBACK_DATABASE_LOG to see the approximate lowest time to which you can flash back.
AUXILIARY DESTINATION 'location'	Specifies the location where temporary database files used during flashback database operations in a multitenant environment are stored. When a CDB uses shared undo, you must specify an auxiliary destination. For CDBs that use local undo, specifying an auxiliary destination is optional.

## Examples

### Example 2-101 FLASHBACK DATABASE to a Specific SCN

Assume that you inserted corrupted rows in many tables at 5:00 p.m. on February 14. You connect SQL\*Plus to the database and query the earliest SCN in the flashback window:

```
SQL> SELECT OLDEST_FLASHBACK_SCN, OLDEST_FLASHBACK_TIME
       2 FROM V$FLASHBACK_DATABASE_LOG;
```

```
OLDEST_FLASHBACK_SCN OLDEST_FLASHBACK
-----
411010 2013/02/14 16:49
```

You then open a new terminal, start the RMAN client, and connect to the target database and recovery catalog. You enter RMAN commands as follows (sample output for the FLASHBACK DATABASE is included):

```
RMAN> SHUTDOWN IMMEDIATE
RMAN> STARTUP MOUNT
RMAN> FLASHBACK DATABASE TO SCN 411010;
```

```
Starting flashback at 15-FEB-13
allocated channel: ORA_DISK_1
channel ORA_DISK_1: SID=104 device type=DISK
```

```
starting media recovery
media recovery complete, elapsed time: 00:00:07
```

```
Finished flashback at 15-FEB-13
```

```
RMAN> ALTER DATABASE OPEN RESETLOGS;
```

### Example 2-102 FLASHBACK DATABASE to a Restore Point

Assume that you are preparing to load a massive number of updates to the database. You create a guaranteed restore point before the performing the updates:

```
SQL> CREATE RESTORE POINT before_update GUARANTEE FLASHBACK DATABASE;
```

The bulk update fails, leaving the database with extensive corrupted data. You start an RMAN session, connect to the target database and recovery catalog, and list the guaranteed restore points:

```
RMAN> LIST RESTORE POINT ALL;
```

SCN	RSP Time	Type	Time	Name
412742		GUARANTEED	15-FEB-13	BEFORE_UPDATE

You mount the database, flash back the database to the restore point (sample output included), and then open the database with the `RESETLOGS` option:

```

RMAN> SHUTDOWN IMMEDIATE
RMAN> STARTUP MOUNT
RMAN> FLASHBACK DATABASE TO RESTORE POINT 'BEFORE_UPDATE';

```

```

Starting flashback at 15-FEB-13
allocated channel: ORA_DISK_1
channel ORA_DISK_1: SID=104 device type=DISK

```

```
starting media recovery
```

```

archived log for thread 1 with sequence 34 is already on disk as file /disk2/
oracle/oradata/prod/arch/archivel_34_614598462.dbf
media recovery complete, elapsed time: 00:00:01
Finished flashback at 15-FEB-13

```

```
RMAN> ALTER DATABASE OPEN RESETLOGS;
```

### Example 2-103 FLASHBACK DATABASE for a PDB to a Guaranteed PDB Restore Point

Assume that you need to upgrade an application that performs DML operations on the tables in the PDB `hr_pdb`. Before you perform the application upgrade, you create a guaranteed PDB restore point in `hr_pdb` when connected to the PDB (the PDB is mounted):

```
SQL> CREATE RESTORE POINT hr_pdb_grp_before_upgrade GUARENTEE FLASHBACK DATABASE;
```

The application upgrade fails leaving the PDB with corrupted data. You want to rewind the PDB to its state before the upgrade failure. You start SQL\*Plus, connect to the CDB as a common user with the `SYSDBA` or `SYSBACKUP` privilege, and then run the following command to view all the restore points:

```
SQL> SELECT name, guarantee_flashback_database, pdb_restore_point, con_id
FROM v$restore_point;
```

NAME	GUARANTEE_FLASHBACK_DATABASE	PDB_RESTORE_POINT	CON_ID
CDB_GRP_BEFORE_PATCH	YES		0
HR_PDB_GRP_BEFORE_UPGRADE	YES		1

The output indicates that the restore point `HR_PDB_GRP_BEFORE_UPGRADE` is a guaranteed PDB restore point. You can reverse the effects of data corruption by rewinding `hr_pdb` to this guaranteed PDB restore point. To perform a flashback operation for `hr_pdb`, this PDB must be closed. All other PDBs in the CDB can remain open and operational.

You place the CDB in mount mode, flash back the PDB to the guaranteed PDB restore point, and then open the PDB with `resetlogs`. In this example, the CDB uses shared

undo and, therefore, an auxiliary instance is used to store temporary files during the flashback operation.

```
RMAN> SHUTDOWN IMMEDIATE;
RMAN> STARTUP MOUNT;
RMAN> FLASHBACK PLUGGABLE DATABASE hr_pdb TO RESTORE POINT hr_pdb_grp_before_upgrade
      AUXILIARY DESTINATION '/temp/aux_dest';
RMAN> ALTER PLUGGABLE DATABASE hr_pdb OPEN RESETLOGS;
```

## 2.24 GRANT

### Purpose

Use the `GRANT` command to assign privileges for a virtual private catalog schema to a database user. By default, a virtual catalog user has no access to the base recovery catalog.

### Prerequisites

Execute this command at the RMAN prompt.

A base recovery catalog must have been created with `CREATE CATALOG` before you can use `GRANT` to assign privileges for a virtual private catalog.

### Usage Notes

The best practice is to create a **base recovery catalog** that stores metadata for all databases. You can then create an Oracle Database user to own the virtual private catalog schema. In Oracle Database 12c Release 1 (12.1.0.1), the virtual private catalog user must be granted the `RECOVERY_CATALOG_OWNER` role. Starting with Oracle Database 12c Release 1 (12.1.0.2), the virtual private catalog user only needs the `CREATE SESSION` privilege.

Connect RMAN to the base recovery catalog and use the `GRANT` command to assign recovery catalog privileges to the virtual catalog owner. Afterwards, run `CREATE VIRTUAL CATALOG` to create a virtual catalog schema for this user. You can use `REVOKE` to revoke catalog privileges.

### Relationship Between Users with CATALOG Privileges on the Same Database

As an illustration of `GRANT` usage, suppose databases `prod1` and `prod2` are registered in the base recovery catalog. While logged in as a user with the `SYSBACKUP` or `SYSDBA` privilege to the base recovery catalog, you create two virtual private catalog users: `VPC1` and `VPC2`. You grant both users `CATALOG FOR DATABASE` access for database `PROD1`, but not `PROD2`.

In this scenario, both `VPC1` and `VPC2` can access the metadata for backups of `PROD1` made by the base recovery catalog owner. Both users can also access the metadata for backups of `PROD1` made by each other. Neither `VPC1` nor `VPC2` can access backup metadata for database `PROD2`.

### Relationship Between GRANT REGISTER and GRANT CATALOG

When you grant `REGISTER DATABASE` to a user, RMAN implicitly grants recovery `CATALOG FOR DATABASE` privileges for any database registered by this user. If you `REVOKE` only the `REGISTER DATABASE` privilege from a user (for example, `VIRTCAT`), then it does not implicitly revoke the `CATALOG FOR DATABASE` privilege for a database registered by `virtcat` (for example, `PROD`). Because the `CATALOG FOR DATABASE` privilege includes registration privileges for `prod`, `virtcat` can continue to unregister and register `prod`. To prevent `VIRTCAT` from



performing any operations on `prod`, including reregistering it, `REVOKE ALL PRIVILEGES` from `VIRTCAT`.

## Syntax

**grant::=**

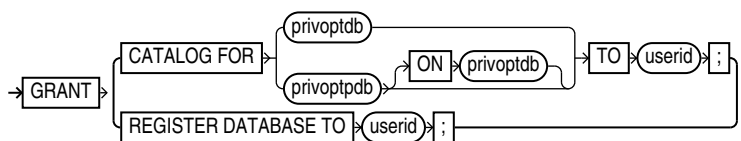

**privoptdb::=**

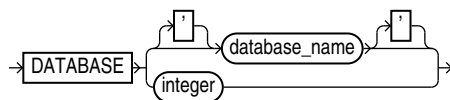

**privoptpdb::=**

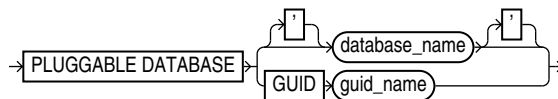

## Semantics

Syntax Element	Description
<code>CATALOG FOR DATABASE [database_name   integer] TO userid</code>	<p>Grants recovery catalog access for the specified database to the specified user.</p> <p><b>Note:</b> The catalog operations granted on the specified database include registering and unregistering this database.</p> <p>Specify the database by either database name or DBID. If you specify a name when multiple databases with this name are registered in the catalog, then RMAN returns an error. In this case, specify the database by DBID.</p> <p>To grant access to databases that are registered in the recovery catalog, you must use the <code>GRANT CATALOG</code> command. You can also grant access for a target database that is not yet registered in the catalog, thereby enabling a virtual private catalog user to register a database. You must grant access by using the DBID of the database that has not yet been registered.</p>
<code>CATALOG FOR PLUGGABLE DATABASE [database_name   GUID guid_name] TO userid</code>	<p>Grants recovery catalog access for the specified pluggable database (PDB) to the specified user.</p> <p>Specify the PDB by using either the PDB name or the PDB GUID. If you specify a PDB name when multiple PDBs with this name are registered in the recovery catalog, then RMAN returns an error. In this case, specify the GUID of the PDB.</p> <p><b>Note:</b> The catalog operations granted on the specified database include registering and unregistering this database.</p>

Syntax Element	Description
REGISTER DATABASE TO <i>userid</i>	<p>Grants the specified user the ability to use REGISTER DATABASE to register databases that are currently unknown to the recovery catalog.</p> <p>When you grant REGISTER DATABASE to a user, RMAN implicitly grants recovery CATALOG FOR DATABASE privileges for any database registered by the user. The CATALOG FOR DATABASE privileges on the database include registering and unregistering this database.</p> <p>For example, assume that user <code>virtcat</code> is granted REGISTER DATABASE and registers database <code>prod</code> in the catalog. RMAN implicitly grants recovery CATALOG FOR DATABASE privileges for <code>prod</code> to <code>virtcat</code>.</p>

## Examples

### Example 2-104 Granting Privileges for a Virtual Private Catalog

Assume that database user `RCO` owns the base recovery catalog in database `CATDB`. This base recovery catalog stores the RMAN metadata for a large number of databases in a data center. Your goal is to create virtual private catalogs for two backup operators in the data center. The database version is Oracle Database 12c Release 1 (12.1.0.2).

You start SQL\*Plus and connect to the `CATDB` database as `SYS`. You then use the CREATE USER statement to create the `BCKOP2` and `BCKOP3` users on `CATDB`. You can grant the CREATE SESSION privilege to these users as follows:

```
SQL> GRANT CREATE SESSION TO bckop2, bckop3;
SQL> EXIT
```

You then start the RMAN client and connect to the recovery catalog database as user `RCO`. You use the RMAN GRANT command to give `BCKOP2` the ability to register any database in her virtual private catalog, but grant `BCKOP3` access to only a subset of the databases in the data center:

```
RMAN> CONNECT CATALOG rco@catdb

recovery catalog database Password: password
connected to recovery catalog database

RMAN> GRANT REGISTER DATABASE TO bckop2;
RMAN> GRANT CATALOG FOR DATABASE prod TO bckop3;
RMAN> GRANT CATALOG FOR DATABASE prodb TO bckop3;
RMAN> EXIT;
```

You start a new RMAN session and connect as user `BCKOP2`. When you connect for the first time, RMAN automatically creates the virtual private catalog. You must exit and restart RMAN after creating each virtual catalog.

```
RMAN> CONNECT CATALOG bckop2@catdb

recovery catalog database Password: password
connected to recovery catalog database

RMAN> EXIT;
```

You start a new RMAN session and connect as user `BCKOP3` to create the virtual private catalog associated with this user:

```

RMAN> CONNECT CATALOG bckop3@catdb

recovery catalog database Password: password
connected to recovery catalog database

RMAN> EXIT;

```

In the following example, backup operator DBA1 uses her virtual private catalog, which is stored in the BCKOP3 schema on CATDB, to store the metadata for a backup of a target database:

```

RMAN> CONNECT TARGET /
RMAN> CONNECT CATALOG bckop3@catdb

recovery catalog database Password: password
connected to recovery catalog database

RMAN> BACKUP DATABASE PLUS ARCHIVELOG;

```

### Example 2-105 Granting Privileges for a PDB

Assume that the recovery catalog owner, in the database `catdb`, is `rco` and the VPC user `vpc1`. You need to grant access to the PDB `mypdb` to `vpc1`.

Connect to the base recovery catalog `rco` by using the following command:

```

RMAN> CONNECT CATALOG rco@catdb

recovery catalog database Password: password
connected to recovery catalog database

```

Use the following command to grant privileges to the access metadata for the PDB `mypdb` to the VPC user `vpc1`:

```

RMAN> GRANT CATALOG FOR PLUGGABLE DATABASE mypdb TO vpc1;

```

## 2.25 HOST

### Purpose

Use the `HOST` command to invoke an operating system command-line sub-shell from within RMAN.

### Syntax

**host::=**



### Prerequisites

Execute this command at the RMAN prompt or within the braces of a [RUN](#) command.

## Semantics

Syntax Element	Description
HOST	Displays a command prompt and resumes after you exit the subshell (see <a href="#">Example 2-106</a> ).
'command'	Runs the command in the specified string and then continues (see <a href="#">Example 2-107</a> ).

## Examples

### Example 2-106 Hosting to the Operating System Within a Backup

This example makes an image copy of data file 3, hosts out to the Linux prompt to check that the copy is in the directory (the Linux session output is indented and displayed in bold), and then resumes the RMAN session:

```

RMAN> BACKUP DATAFILE 3 FORMAT '/disk2/df3.cpy';

Starting backup at 15-FEB-13
using channel ORA_DISK_1
channel ORA_DISK_1: starting full datafile backup set
channel ORA_DISK_1: specifying datafile(s) in backup set
input datafile file number=00003 name=/disk1/oracle/oradata/prod/undotbs01.d bf
channel ORA_DISK_1: starting piece 1 at 15-FEB-13
channel ORA_DISK_1: finished piece 1 at 15-FEB-13
piece handle=/disk2/df3.cpy tag=TAG20130215T111326 comment=NONE
channel ORA_DISK_1: backup set complete, elapsed time: 00:00:01
Finished backup at 15-FEB-13

RMAN> HOST;

% ls /disk2/df3.cpy
/disk2/df3.cpy
% exit
exit
host command complete

RMAN>

```

### Example 2-107 Executing an Operating System Copy Within RMAN

This example makes a backup of data file `system01.dbf` and then executes the Linux `ls` command to display all files in the `/disk2` directory:

```

BACKUP DATAFILE '?/oradata/prod/system01.dbf'
  FORMAT '/disk2/system01.dbf';
HOST 'ls -lt /disk2/*';

```

## 2.26 IMPORT CATALOG

### Purpose

Use the `IMPORT CATALOG` command to import the metadata from one recovery catalog schema into a different catalog schema. If you created catalog schemas of different versions to store metadata for multiple target databases, then this command enables you to maintain a single catalog schema for all databases.

**See Also:**[CREATE CATALOG](#)**Prerequisites**

RMAN must be connected to the destination recovery catalog, which is the catalog into which you want to import catalog data. This recovery catalog must not be a virtual private catalog.

No target database connection is needed to merge catalog schemas. Execute this command at the RMAN prompt.

The version of the source recovery catalog schema must be equal to the current version of the destination recovery catalog schema. If they are not equal, then upgrade the schemas to the same version.

Ensure that the same database is not registered in both the source recovery catalog schema and destination catalog schema. If a database is registered in both schemas, then [UNREGISTER](#) this database from source recovery catalog and execute the `IMPORT` command again.

**Usage Notes**

If the operation fails in the middle of the import, then the import is rolled back. Thus, a partial import is not permitted. The unregister operation is separate from the import. By default, the imported database IDs are unregistered from the source recovery catalog schema after a successful import.

Stored scripts are either global or local. It is possible for global scripts, but not local scripts, to have name conflicts during import because the destination schema contains an object with the same name. In this case, RMAN renames the global script name to `COPY OF script_name`. For example, RMAN renames `bp_cmd` to `COPY OF bp_cmd`.

If the renamed global script is still not unique, then RMAN renames it to `COPY(2) OF script_name`. If this script name also exists, then RMAN renames the script to `COPY(3) OF script_name`. RMAN continues the `COPY(n) OF` pattern until the script is uniquely named.

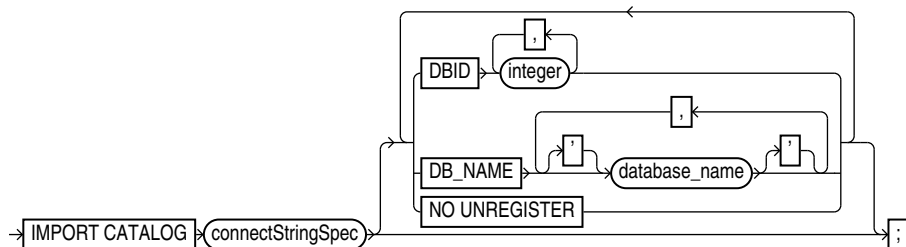
**Syntax****`import::=`**`(connectStringSpec::=)`

## Semantics

Syntax Element	Description
<code>connectStringSpec</code>	Specifies the connection string for the source recovery catalog, which is the catalog whose metadata is imported.
DBID <i>integer</i>	Specifies the list of DBIDs for the databases whose metadata is imported from the source catalog schema (see <a href="#">Example 2-109</a> ). When not specified, RMAN merges metadata for all database IDs from the source catalog schema into the destination catalog schema. RMAN issues an error if the database whose metadata is merged is already registered in the recovery catalog schema.
DB_NAME <i>database_name</i>	Specifies the list of databases whose metadata is imported from the source catalog schema (see <a href="#">Example 2-109</a> ). When not specified, RMAN merges metadata for all databases from the source catalog schema into the destination catalog schema. RMAN issues an error if the same DBID is registered in both recovery catalogs.
NO UNREGISTER	Forces RMAN to keep imported database IDs in the source catalog schema. By default, the imported database IDs are unregistered from source recovery catalog schema.

## Examples

**Example 2-108 Importing Metadata for All Registered Databases**

In this example, database `prod` contains a 10.2 catalog schema owned by user `rcat`, while database `catdb` contains an 11.1 catalog schema owned by user `rco`. RMAN imports metadata for all database IDs registered in `rcat` into the recovery catalog owned by `rco`. All target databases registered in `rcat` are unregistered.

```

RMAN> CONNECT CATALOG rco@catdb

recovery catalog database Password: password
connected to recovery catalog database

RMAN> IMPORT CATALOG rcat@prod;

Starting import catalog at 15-FEB-13
source recovery catalog database Password: password
connected to source recovery catalog database
import validation complete
database unregistered from the source recovery catalog
Finished import catalog at 15-FEB-13

```

**Example 2-109 Importing Metadata for a Subset of Registered Databases**

This example is a variation on [Example 2-108](#). Instead of importing the entire recovery catalog, it imports only the metadata for the database with DBID 1618984270.

```

RMAN> CONNECT CATALOG rco@catdb

recovery catalog database Password: password
connected to recovery catalog database

RMAN> IMPORT CATALOG rcat@inst1 DBID=1618984270;

Starting import catalog at 15-FEB-13

```

```
source recovery catalog database Password: password
connected to source recovery catalog database
import validation complete
database unregistered from the source recovery catalog
Finished import catalog at 15-FEB-13
```

## 2.27 LIST

### Purpose

Use the `LIST` command to display backups and information about other objects recorded in the RMAN repository.



#### See Also:

*Oracle Database Backup and Recovery User's Guide* to learn how to make lists and reports, and [REPORT](#)

### Additional Topics

- [Prerequisites](#)
- [Usage Notes](#)
- [Syntax](#)
- [Semantics](#)
- [LIST Command Output](#)
- [Examples](#)

### Prerequisites

Execute `LIST` only at the RMAN prompt. Either of the following conditions must be met:

- RMAN must be connected to a target database. If RMAN is *not* connected to a recovery catalog, and if you are not executing the `LIST FAILURE` command, then the target database must be mounted or open. If RMAN *is* connected to a recovery catalog, then the target database instance must be started.
- RMAN must be connected to a recovery catalog and `SET DBID` must have been run.

To list preplugin backups, you must connect to the root as a common user with the `SYSDBA` or `SYSBACKUP` privilege.

### Usage Notes

Except for `LIST FAILURE`, the `LIST` command displays the backups and copies against which you can run `CROSSCHECK` and `DELETE` commands. The `LIST FAILURE` command displays failures against which you can run the `ADVISE FAILURE` and `REPAIR FAILURE` commands.

 **Note:**

Starting in Oracle Database 19c, the Data Recovery Advisor (DRA) feature is deprecated.

The deprecation of DRA includes deprecation of the following Oracle Recovery Manager (RMAN) commands: `LIST FAILURE`, `ADVISE FAILURE`, `REPAIR FAILURE`, and `CHANGE FAILURE`. Database administrators will no longer have access to these commands. There is no replacement feature for DRA.

"[RMAN Backups in a Data Guard Environment](#)" explains how RMAN handles backups in a Data Guard environment. In general, RMAN considers tape backups created on one database in the environment as accessible to all databases in the environment, whereas disk backups are accessible only to the database that created them. In a Data Guard environment, `LIST` displays those files that are accessible to the connected target database.

RMAN prints the `LIST` output to either standard output or the message log, but not to both at the same time.

**Syntax**

***list::=***



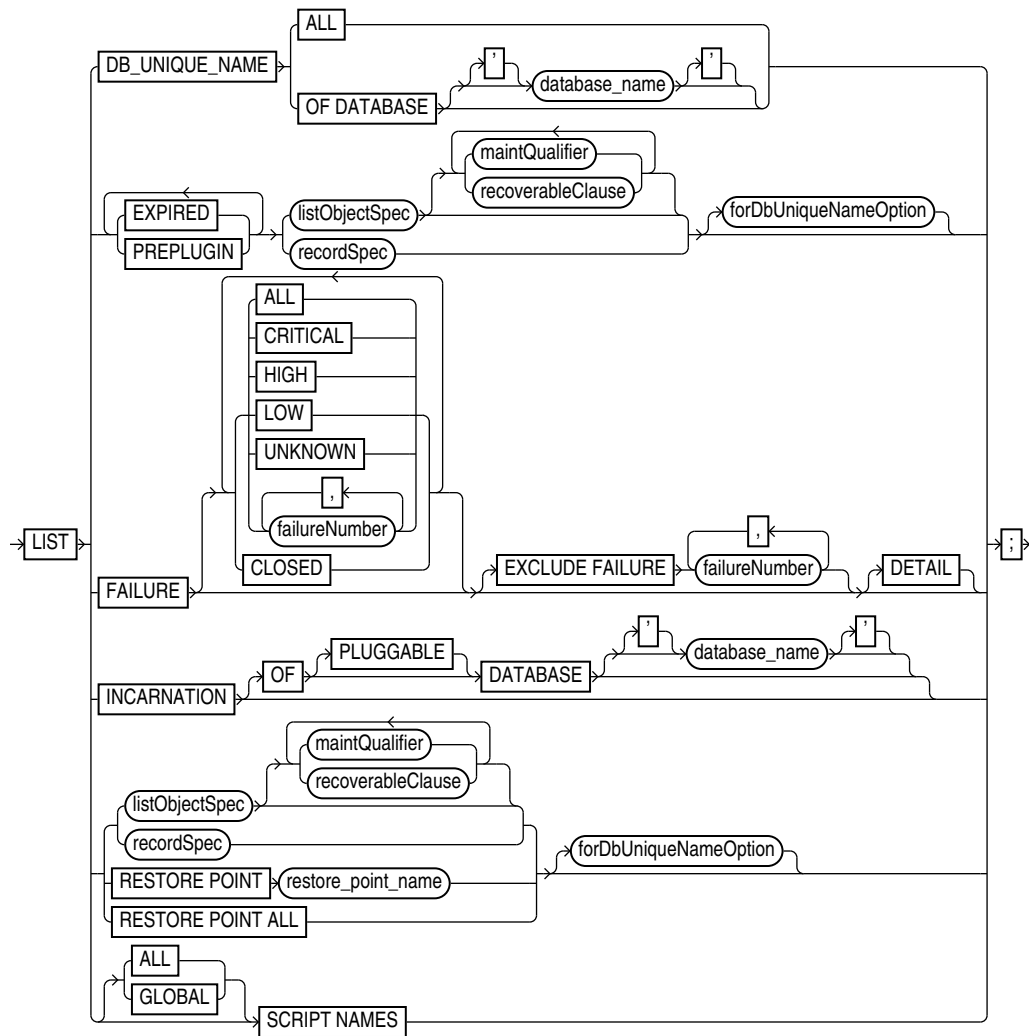

(listObjectSpec::=, recordSpec::=, maintQualifier::=, forDbUniqueNameOption::=, untilClause::=)

***maintQualifier::=***

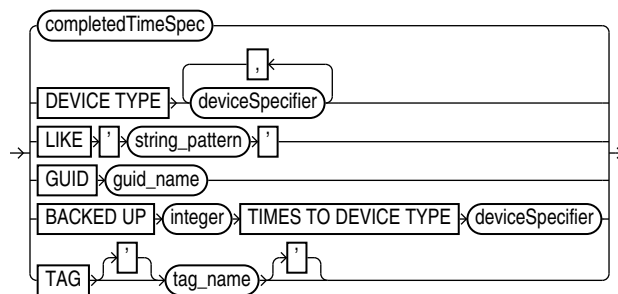

(completedTimeSpec::=, deviceSpecifier::=)

***listObjectSpec::=***

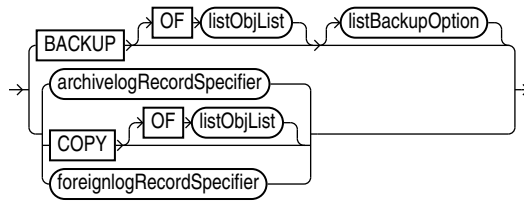

(listObjList::=, listBackupOption::=, archivelogRecordSpecifier::=, foreignlogRecordSpecifier::=)

**recoverableClause::=**

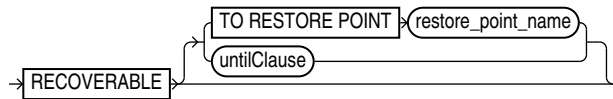

(untilClause::=)

**listBackupOption::=**

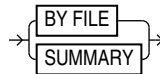

## Semantics

### list

Syntax Element	Description
DB_UNIQUE_NAME	Lists the DB_UNIQUE_NAME of one or more databases registered in the recovery catalog.  RMAN must be connected to a recovery catalog. RMAN must also be connected to a mounted or open target database, or you must identify the target database with the <a href="#">SET DBID</a> command. The DBID for a primary database is identical to the DBID of its associated standby databases: they are distinguished by DB_UNIQUE_NAME.  <b>See Also:</b> <a href="#">Table 2-28</a> for a description of the output
ALL	Lists the DB_UNIQUE_NAME of every database registered in the RMAN repository.
OF DATABASE database_name	Lists the DB_UNIQUE_NAME of every database with the specified DB_NAME.
EXPIRED	Displays backup sets, proxy copies, and image copies marked in the repository as EXPIRED, which means they were not found. See <a href="#">Table 2-9</a> for a description of the output.  To ensure that LIST EXPIRED shows up-to-date output, use a <a href="#">CROSSCHECK</a> command periodically. When you use a CROSSCHECK command, RMAN searches disk and tape for backups and copies recorded in the repository. If it does not find them, then it updates their repository records to status EXPIRED.
PREPLUGGIN	Lists preplugin backups.

---

Syntax Element	Description
<a href="#">listObjectSpec</a>	Specifies the type of expired object or objects that you are listing. <b>See Also:</b> <a href="#">listObjectSpec</a>
<a href="#">maintQualifier</a>	Restricts the range of the listing. <b>See Also:</b> <a href="#">maintQualifier</a>
<a href="#">recordSpec</a>	To display backups of PDBs that were dropped, use the <code>GUID</code> option with the <code>LIST</code> command and specify the GUID of the dropped PDB. Query the <code>dba_pdb_history</code> view to determine the GUID, of dropped PDBs. Specifies the expired object or objects that you are listing. <b>See Also:</b> <a href="#">recordSpec</a>
<a href="#">forDbUniqueNameOption</a>	Lists the expired files in <a href="#">listObjectSpec</a> or <a href="#">recordSpec</a> that are exclusively associated with the specified <code>DB_UNIQUE_NAME</code> in a Data Guard environment. You can specify a database with <code>db_unique_name</code> or use <code>ALL</code> for all uniquely named databases recorded in the catalog for a particular DBID. A database is uniquely identified in the recovery catalog by a DBID and the value of the <code>DB_UNIQUE_NAME</code> initialization parameter. RMAN must be connected to a recovery catalog. RMAN must also be connected to a mounted or open target database, or you must have run the <code>SET DBID</code> command. <b>See Also:</b> <a href="#">forDbUniqueNameOption</a> for descriptions of the options in this clause

---

Syntax Element	Description
FAILURE	<p>Lists failures recorded by the Data Recovery Advisor. The database to which RMAN is connected must be a single-instance database and must not be a physical standby database.</p> <p><b>See Also:</b> "Oracle RAC and Data Recovery Advisor"</p> <p>The Data Recovery Advisor can detect and repair a wide variety of physical problems that cause data loss and corruption. Physical corruptions are typically caused by faulty I/O subsystems or human error. The Data Recovery Advisor may not detect or handle some types of logical corruptions. Corruptions of this type require help from Oracle Support Services.</p> <p>For Data Recovery Advisor, a <b>failure</b> is a persistent data corruption that is mapped to a set of repair actions. Data failures are detected by checks, which are diagnostic procedures that assess the health of the database or its components. Each check can diagnose one or more failures, which are mapped to a set of repairs.</p> <p>The typical use case is to run <code>LIST FAILURE</code> to list any failures, then use <code>ADVISE FAILURE</code> to display repair options, and <code>REPAIR FAILURE</code> to fix the failures. Run these commands in the same RMAN session.</p> <p>Starting in Oracle Database 19c, the Data Recovery Advisor (DRA) feature is deprecated.</p> <p>The deprecation of DRA includes deprecation of the following Oracle Recovery Manager (RMAN) commands: <code>LIST FAILURE</code>, <code>ADVISE FAILURE</code>, <code>REPAIR FAILURE</code>, and <code>CHANGE FAILURE</code>. Database administrators will no longer have access to these commands. There is no replacement feature for DRA.</p> <p>If no options are specified on <code>LIST FAILURE</code>, then the command lists only the highest priority failures that have status <code>OPEN</code>. Therefore, <code>CRITICAL</code> and <code>HIGH</code> failures are always listed in the command output if they exist. Failures with <code>LOW</code> priority are listed only if no <code>CRITICAL</code> or <code>HIGH</code> priority failures exist. Failures are sorted in reverse order of occurrence, with the most recent failure listed first.</p> <p>The <code>LIST FAILURE</code> command does not initiate checks to diagnose new failures; rather, it lists the results of previously executed assessments. Thus, repeatedly executing <code>LIST FAILURE</code> reveals new failures only if the database automatically diagnosed them in response to errors that occurred in between command executions. However, <code>LIST FAILURE</code> revalidates all existing failures when the command is issued. If a user fixed failures manually, or if the failures were transient problems that disappeared, then Data Recovery Advisor removes these failures from the <code>LIST FAILURE</code> output.</p> <p><b>See Also:</b> <a href="#">Table 2-27</a> for an explanation of the column headings of the <code>LIST FAILURE</code> output table and <a href="#">Example 2-115</a> for an illustration</p>
ALL	Lists failures with all priorities and status <code>OPEN</code> .
CRITICAL	Lists only critical failures with status <code>OPEN</code> .
HIGH	Lists only failures with <code>HIGH</code> priority and status <code>OPEN</code> .
LOW	Lists only failures with <code>LOW</code> priority with status <code>OPEN</code> .
UNKNOWN	Lists only failures whose priority cannot be determined until the database is mounted.
<i>failureNumber</i>	Specifies the failures by failure number.
CLOSED	Lists only closed failures.
EXCLUDE FAILURE <i>failureNumber</i>	Excludes the specified failures from the list.

Syntax Element	Description
DETAIL	Lists failures by expanding the consolidated failure. For example, if multiple block corruptions existed in a file, then specifying the <code>DETAIL</code> option would list each of the block corruptions.
INCARNATION	Displays information about the incarnations of a database.  Whenever you open a database with the <code>RESETLOGS</code> option, you create a new incarnation of the database. If <code>LIST INCARNATION</code> displays $n$ incarnations of a database, then you have reset the online redo logs for this database $n-1$ times.  The <code>LIST</code> output includes the primary keys of all database incarnation records for the specified database name (in the column <code>Inc Key</code> , which contains the incarnation key). Use the key in a <code>RESET DATABASE</code> command to change the incarnation that RMAN considers to be current to a previous incarnation.  <b>See Also:</b> <a href="#">Table 2-24</a> for an explanation of the column headings of the <code>LIST INCARNATION</code> output table and <a href="#">Example 2-114</a> for an illustration
OF DATABASE <i>database_name</i>	Specifies the name of the database. If you do not specify the <code>OF DATABASE</code> option, then <code>LIST</code> displays all databases registered in the recovery catalog.
OF PLUGGABLE DATABASE <i>pluggable_database_name</i>	Specifies the name of the PDB. Information about all incarnations of the specified PDB is displayed. You must connect to the root as a common user with the <code>SYSDBA</code> or <code>SYSEBACKUP</code> privilege.
<a href="#">listObjectSpec</a>	Specifies the type of expired object or objects that you are listing.  <b>See Also:</b> <a href="#">listObjectSpec</a>
<a href="#">maintQualifier</a>	Restricts the range of the listing.  <b>See Also:</b> <a href="#">maintQualifier</a>
<a href="#">recoverableClause</a>	Restricts the list to data file backups or copies whose status in the repository is <code>AVAILABLE</code> and which can be used for restore and recovery in the current incarnation of the target database.  <b>See Also:</b> <a href="#">recoverableClause</a>
<a href="#">recordSpec</a>	Specifies the object or objects that you are listing.  <b>See Also:</b> <a href="#">recordSpec</a>
<a href="#">untilClause</a>	Specifies an end time, SCN, or log sequence number.  <b>See Also:</b> <a href="#">untilClause</a>
RESTORE POINT	Displays restore points known to the RMAN repository.  <b>See Also:</b> <a href="#">Table 2-26</a> for an explanation of the column headings of the <code>LIST RESTORE POINT</code> output table
<i>restore_point_name</i>	Displays the specified restore point.
ALL	Displays all restore points known to the RMAN repository.
<a href="#">forDbUniqueNameOption</a>	Lists the backups and restore points that are exclusively associated with the specified <code>DB_UNIQUE_NAME</code> in a Data Guard environment.  You can specify a database with <i>db_unique_name</i> or use <code>ALL</code> for all uniquely named databases recorded in the catalog for a particular DBID. A database is uniquely identified in the recovery catalog by a DBID and the value of the <code>DB_UNIQUE_NAME</code> initialization parameter.  RMAN must be connected to a recovery catalog. RMAN must also be connected to a mounted or open target database.  <b>See Also:</b> <a href="#">forDbUniqueNameOption</a> for descriptions of the options in this clause

Syntax Element	Description
ALL SCRIPT NAMES	RMAN lists all global and local scripts defined for all databases in the connected recovery catalog, along with any descriptive comments. You must be connected to a recovery catalog, but you do not need to be connected to a target database.
GLOBAL SCRIPT NAMES	RMAN lists only global scripts defined in the connected recovery catalog, along with any descriptive comments. You must be connected to a recovery catalog, but you do not need to be connected to a target database.
SCRIPT NAMES	Lists local and global scripts that can be executed on the current target database. You must be connected to a target database and a recovery catalog to use this form of the command. <b>See Also:</b> <a href="#">Table 2-25</a> for a description of the output and <a href="#">Example 3-19</a> for an illustration

### *listObjectSpec*

This subclause specifies the type of object or objects that you are listing.

Syntax Element	Description
BACKUP	Displays information about backup sets (including detail on backup pieces) and proxy copies. <b>See Also:</b> <a href="#">Table 2-9</a> for a description of LIST BACKUP output and <a href="#">Example 2-110</a> for an illustration
OF <a href="#">listObjList</a>	Restricts the list of objects operated on to the object type specified in the <i>listObjList</i> clause. If you do not specify an object, then LIST defaults to OF DATABASE CONTROLFILE ARCHIVELOG ALL. <b>Note:</b> The LIST BACKUP ... LIKE command is not valid. The only valid exception is LIST BACKUP OF ARCHIVELOG LIKE. <b>See Also:</b> <a href="#">listObjList</a>
<a href="#">listBackupOption</a>	Specifies whether to list summary information about backups or detailed information.
<a href="#">archivelogRecordSpecifier</a>	Displays information about a range of archived redo log files.
COPY	Displays only information about data file copies, archived redo log files, and image copies of archived redo log files. By default, LIST COPY displays copies of all database files and archived redo log files. Both usable and unusable image copies are included in the output, even those that cannot be restored or are expired or unavailable. <b>See Also:</b> <a href="#">Table 2-21</a> and <a href="#">Table 2-23</a> for an explanation of the column headings of the LIST COPY output tables
OF <a href="#">listObjList</a>	Restricts the list of objects operated on to the object type specified in the <i>listObjList</i> clause. <b>See Also:</b> <a href="#">listObjList</a>
<a href="#">foreignlogRecordSpecifier</a>	Displays information about a range of foreign archived redo log files.

### *recoverableClause*

This subclause specifies recoverable backups.

Syntax Element	Description
RECOVERABLE	Restricts the list to expired data file backups or copies whose status in the repository is <code>AVAILABLE</code> and which can be used for restore and recovery in the current incarnation of the target database. This list includes all backups and copies except the incremental backups that have no valid parent to which the incremental can be applied.
TO RESTORE POINT <i>restore_point_name</i>	Specifies a restore point, with the SCN at which the restore point was created as the upper, inclusive limit. Because the limit is inclusive, RMAN only lists files that are recoverable up to <i>and including</i> the SCN corresponding to the restore point.
<a href="#">untilClause</a>	Specifies an end time, SCN, or log sequence number. <b>See Also:</b> <a href="#">untilClause</a>

### ***listBackupOption***

Specifies whether to summarize backups or list the backups for a particular data file.

Syntax Element	Description
BY FILE	Lists backups of each data file, archived redo log file, control file, and server parameter file. <b>See Also:</b> <a href="#">Table 2-18</a> , <a href="#">Table 2-19</a> , and <a href="#">Table 2-20</a> for a description of <code>LIST BACKUP ... BY FILE</code> output
SUMMARY	Gives a one-line summary for each backup. <b>See Also:</b> <a href="#">Table 2-16</a> for a description of <code>LIST BACKUP ... SUMMARY</code> output and <a href="#">Example 2-111</a> for sample output

### **LIST Command Output**

The information that appears in the output is described in the following tables:

- [Table 2-9](#)
- [Table 2-10](#)
- [Table 2-11](#)
- [Table 2-12](#)
- [Table 2-13](#)
- [Table 2-14](#)
- [Table 2-15](#)
- [Table 2-16](#)
- [Table 2-17](#)
- [Table 2-18](#)
- [Table 2-19](#)
- [Table 2-20](#)
- [Table 2-21](#)
- [Table 2-22](#)
- [Table 2-23](#)

- [Table 2-24](#)
- [Table 2-25](#)
- [Table 2-26](#)
- [Table 2-27](#)
- [Table 2-28](#)

**Table 2-9 List of Backup Sets (for data file backup sets)**

Column	Indicates
BS Key	A unique key identifying this backup set. If RMAN is connected to a recovery catalog, then BS Key is the primary key of the backup set in the catalog. It corresponds to BS_KEY in the RC_BACKUP_SET view. If RMAN is connected in the default NOCATALOG mode, then BS Key displays the RECID from V\$BACKUP_SET.
Type	The type of backup: Full or Incr (incremental). <b>Note:</b> Column only included in data file backup sets.
LV	The level of the backup: NULL for nonincrementals, level 0 or level 1 for incrementals. <b>Note:</b> Column only included in data file backup sets.
Size	The size of the backup in bytes. <b>Note:</b> Column only included in data file backup sets.
Device Type	The type of device on which the backup was made, for example, DISK or sbt.
Elapsed Time	The duration of the backup.
Completion Time	The date and time that the backup set completed. The format of this field depends on the NLS_LANG and NLS_DATE_FORMAT environment settings.
List of data files in backup set ...	See <a href="#">Table 2-11</a>

**Table 2-10 List of Backup Pieces (for sets with only one piece)**

Column	Indicates
BP Key	A unique identifier for this backup piece in the recovery catalog or target database control file. If RMAN is connected to a recovery catalog, then BP Key is the primary key of the backup piece in the catalog. It corresponds to BP_KEY in the RC_BACKUP_PIECE view. If RMAN is connected in NOCATALOG mode, then BP Key displays the RECID from V\$BACKUP_PIECE. <b>Note:</b> The values for KEY in the recovery catalog and the control file are different.
Status	The backup piece status: AVAILABLE, UNAVAILABLE, or EXPIRED (refer to the <a href="#">CHANGE</a> , <a href="#">CROSSCHECK</a> , and <a href="#">DELETE</a> commands for an explanation of each status).
Compressed	Whether the backup piece is compressed (YES or NO).



**Table 2-10 (Cont.) List of Backup Pieces (for sets with only one piece)**

Column	Indicates
Tag	The tag applied to the backup set. Tag names are not case sensitive and appear in all uppercase.
Piece Name/Handle	The file name or handle of the backup piece. If the backup piece is on SBT, then the Media ID is displayed with the name.
SPFILE Included	A server parameter file is included in the backup.
Control File Included	A control file is included in the backup. <b>Note:</b> This row appears only if the current control file is included in the backup.
Ckp SCN	The SCN of the backup control file checkpoint. All database changes recorded in the redo records before the specified SCN are reflected in this control file. <b>Note:</b> This row appears only if the current control file is included in the backup.
Ckp time	The time of the backup control file checkpoint. All database changes recorded in the redo records before the specified time are reflected in this control file. <b>Note:</b> This row appears only if the current control file is included in the backup.

**Table 2-11 List of Data Files in backup set ...**

Column	Indicates
File	The number of the file that was backed up.
LV	The level of the backup: NULL for nonincrementals, level 0 or 1 for incrementals.
Type	The type of backup: Full or Incr (incremental).
Ckp SCN	The checkpoint of the data file at the time it was backed up. All database changes before the SCN were written to the file; changes after the specified SCN were not written to the file.
Ckp Time	The checkpoint of the data file at the time it was backed up. All database changes before the time were written to the file; changes after the specified time were not written to the file.
Name	The location where this file would be restored now if it were restored from this backup set and no <a href="#">SET NEWNAME</a> command was entered. <b>See Also:</b> <a href="#">SET</a>

**Table 2-12 List of Archived Logs in backup set ...**

Column	Indicates
Thrd	The thread number of the redo log.
Seq	The log sequence number of the archived log.
Low SCN	The lowest SCN in the archived log.

**Table 2-12 (Cont.) List of Archived Logs in backup set ...**

Column	Indicates
Low Time	The time when the database switched into the redo log having this sequence number.
Next SCN	The low SCN of the next archived log sequence.
Next Time	The low time of the next archived log sequence.

**Table 2-13 Backup Set Copy ... of backup set ... (only if multiple pieces)**

Column	Indicates
Device Type	The type of device on which the backup was made, for example, DISK or sbt.
Elapsed Time	The duration of the backup.
Completion Time	The date and time that the backup set completed. The format of this field depends on the NLS_LANG and NLS_DATE_FORMAT environment settings.
Tag	The tag applied to the backup set. Tag names are not case sensitive and appear in all uppercase.

**Table 2-14 List of Backup Pieces for backup set ... Copy ... (if multiple pieces)**

Column	Indicates
BP Key	<p>A unique identifier for this backup piece in the recovery catalog or target database control file.</p> <p>If RMAN is connected to a recovery catalog, then BP Key is the primary key of the backup piece in the catalog. It corresponds to BP_KEY in the RC_BACKUP_PIECE view. If RMAN is connected in NOCATALOG mode, then BP Key displays the RECID from V\$BACKUP_PIECE.</p> <p><b>Note:</b> The values for KEY in the recovery catalog and the control file are different.</p>
Pc#	The number of the backup piece in the backup set.
Status	The backup piece status: AVAILABLE, UNAVAILABLE, or EXPIRED (refer to the <a href="#">CHANGE</a> , <a href="#">CROSSCHECK</a> , and <a href="#">DELETE</a> commands for an explanation of each status).
Piece Name	The file name or handle of the backup piece. If the backup piece is stored on SBT, then the media ID is also displayed.

**Table 2-15 List of Proxy Copies**

Column	Indicates
PC Key	A unique key identifying this proxy copy. If RMAN is connected to a catalog, then <code>PC Key</code> is the primary key of the proxy copy in the catalog. It corresponds to <code>XDF_KEY</code> in the <code>RC_PROXY_DATAFILE</code> view or <code>XCF_KEY</code> in the <code>RC_PROXY_CONTROLFILE</code> view. If RMAN is connected in <code>NOCATALOG</code> mode, then <code>PC Key</code> displays the <code>RECID</code> from <code>V\$PROXY_DATAFILE</code> .
File	The absolute data file number of the file that was copied.
Status	The proxy copy status: <code>AVAILABLE</code> , <code>UNAVAILABLE</code> , or <code>EXPIRED</code> (refer to the <a href="#">CHANGE</a> , <a href="#">CROSSCHECK</a> , and <a href="#">DELETE</a> commands for an explanation of each status).
Completion Time	The date and time that the backup set completed. The format of this field depends on the <code>NLS_LANG</code> and <code>NLS_DATE_FORMAT</code> environment settings.
Ckp SCN	The SCN of the proxy copy control file checkpoint. All database changes recorded in the redo records before the specified SCN are reflected in this control file.
Ckp time	The time of the proxy copy control file checkpoint. All database changes recorded in the redo records before the specified time are reflected in this control file.
Datafile name	The location where this file would be restored now if it were restored from this backup set and no <code>SET NEWNAME</code> command was entered. <b>See Also:</b> <a href="#">SET</a> command
Handle	The media manager's handle for the proxy copy. If the object is on <code>sbt</code> , then the media ID is also displayed.
Tag	The tag applied to the proxy copy. Tag names are not case sensitive and appear in all uppercase.

**Table 2-16 List of Backup Sets (LIST BACKUP ... SUMMARY)**

Column	Indicates
Key	A unique key identifying this backup set. If RMAN is connected to a recovery catalog, then <code>BS Key</code> is the primary key of the backup set in the catalog. It corresponds to <code>BS_KEY</code> in the <code>RC_BACKUP_SET</code> view. If RMAN is connected in <code>NOCATALOG</code> mode, then <code>BS Key</code> displays the <code>RECID</code> from <code>V\$BACKUP_SET</code> .
TY	The type of backup: backup set (B) or proxy copy (P).
LV	For incremental backups, the incremental backup level (0 or 1). For backup sets containing full backups of data files, F. For backup sets containing archived redo log files, A.

**Table 2-16 (Cont.) List of Backup Sets (LIST BACKUP ... SUMMARY)**

Column	Indicates
S	The status of the backup: A (available), U (unavailable), or X (all backup pieces in set expired). Refer to the <a href="#">CHANGE</a> , <a href="#">CROSSCHECK</a> , and <a href="#">DELETE</a> commands for an explanation of each status.
Device Type	The type of device on which the backup was made, for example, DISK or sbt.
Completion Time	The date and time that the backup set completed. The format of this field depends on the NLS_LANG and NLS_DATE_FORMAT environment settings.
#Pieces	The number of backup pieces in the backup set.
#Copies	The number of copies made of each backup piece in the set. The number is 1 if no duplexing was performed. Otherwise, the value ranges from 2 to 4.
Compressed	YES if the backup set was compressed by RMAN; NO if not compressed by RMAN.
Tag	The tag applied to the backup set. An asterisk (*) indicates that backup pieces have different tags within the same backup set, which occurs when a user changes the tag when using CATALOG or BACKUP BACKUPSET. Tag names are not case sensitive and appear in all uppercase.

**Table 2-17 List of Backup Pieces (LIST BACKUPPIECE ...)**

Column	Indicates
BP Key	A unique identifier for this backup piece in the recovery catalog or target database control file.  If RMAN is connected to a catalog, then BP Key is the primary key of the backup piece in the catalog. It corresponds to BP_KEY in the RC_BACKUP_PIECE view. If RMAN is connected in NOCATALOG mode, then BP Key displays the RECID from V\$BACKUP_PIECE.  <b>Note:</b> The values for KEY in the recovery catalog and the control file are different.
BS Key	A unique key identifying this backup set.  If RMAN is connected to a recovery catalog, then BS Key is the primary key of the backup set in the catalog. It corresponds to BS_KEY in the RC_BACKUP_SET view. If RMAN is connected in NOCATALOG mode, then BS Key displays the RECID from V\$BACKUP_SET.
Pc#	The number of the backup piece in the backup set.
Cp#	The copy number of this backup piece in the backup set. The number is 1 if no duplexing was performed. Otherwise, the value ranges from 2 to 4.
Status	The backup piece status: AVAILABLE, UNAVAILABLE, or EXPIRED (refer to the <a href="#">CHANGE</a> , <a href="#">CROSSCHECK</a> , and <a href="#">DELETE</a> commands for an explanation of each status).

**Table 2-17 (Cont.) List of Backup Pieces (LIST BACKUPPIECE ...)**

Column	Indicates
Device Type	The type of device on which the backup was made, for example, DISK or sbt.
Piece Name	The file name or handle of the backup piece. If the piece is stored on SBT, then the Handle and media ID are displayed.

**Table 2-18 List of Datafile Backups (LIST BACKUP ... BY FILE)**

Column	Indicates
File	The absolute data file number.
Key	A unique key identifying this backup set. If RMAN is connected to a recovery catalog, then <i>Key</i> is the primary key of the backup set in the catalog. It corresponds to <i>BS_KEY</i> in the <i>RC_BACKUP_SET</i> view. If RMAN is connected to a target database in <i>NOCATALOG</i> mode, then <i>Key</i> displays the <i>RECID</i> from <i>V\$BACKUP_SET</i> .
TY	The type of backup: backup set (B) or proxy copy (P).
LV	The backup level: F for nonincrementals, level 0 or 1 for incrementals.
S	The status of the backup: A (available), U (unavailable), or X (all backup pieces in set expired). Refer to the <a href="#">CHANGE</a> , <a href="#">CROSSCHECK</a> , and <a href="#">DELETE</a> commands for an explanation of each status.
Ckp SCN	The checkpoint of the data file at the time it was backed up. All database changes prior to the SCN have been written to the file; changes after the specified SCN have not been written to the file.
Ckp Time	The checkpoint of the data file at the time it was backed up. All database changes prior to the time have been written to the file; changes after the specified time have not been written to the file.
#Pieces	The number of backup pieces in the backup set.
#Copies	The number of copies made of each backup piece in the set. The number is 1 if no duplexing was performed. Otherwise, the value ranges from 2 to 4.
Compressed	YES if the backup was compressed by RMAN; NO if not compressed by RMAN.
Tag	The tag applied to the backup set. An asterisk (*) indicates that backup pieces have different tags within the same backup set, which occurs when a user changes the tag when using <i>CATALOG</i> or <i>BACKUP BACKUPSET</i> . Tag names are not case sensitive and appear in all uppercase.

**Table 2-19 List of Archived Log Backups (LIST BACKUP ... BY FILE)**

Column	Indicates
Thrd	The thread number of the redo log.

**Table 2-19 (Cont.) List of Archived Log Backups (LIST BACKUP ... BY FILE)**

Column	Indicates
Seq	The log sequence number of the archived log.
Low SCN	The lowest SCN in the archived log.
Low Time	The time when the database switched into the redo log having this sequence number.
BS Key	A unique key identifying this backup set. If RMAN is connected to a recovery catalog, then <code>BS Key</code> is the primary key of the backup set in the catalog. It corresponds to <code>BS_KEY</code> in the <code>RC_BACKUP_SET</code> view. If RMAN is connected in <code>NOCATALOG</code> mode, then <code>BS Key</code> displays the <code>RECID</code> from <code>V\$BACKUP_SET</code> .
S	The status of the backup: A (available), U (unavailable), or X (all backup pieces in set expired). Refer to the <a href="#">CHANGE</a> , <a href="#">CROSSCHECK</a> , and <a href="#">DELETE</a> commands for an explanation of each status.
#Pieces	The number of backup pieces in the backup set.
#Copies	The number of copies made of each backup piece in the set. The number is 1 if no duplexing was performed. Otherwise, the value ranges from 2 to 4.
Compressed	YES if the backup was compressed by RMAN; NO if not compressed by RMAN.
Tag	The tag applied to the backup set. Tag names are not case sensitive and appear in all uppercase.

**Table 2-20 List of Control File Backups (LIST BACKUP ... BY FILE)**

Column	Indicates
CF Ckp SCN	Checkpoint SCN of the control file.
Ckp Time	The log sequence number of the archived log.
BS Key	A unique key identifying this backup set. If RMAN is connected to a recovery catalog, then <code>BS Key</code> is the primary key of the backup set in the catalog. It corresponds to <code>BS_KEY</code> in the <code>RC_BACKUP_SET</code> view. If RMAN is connected in <code>NOCATALOG</code> mode, then <code>BS Key</code> displays the <code>RECID</code> from <code>V\$BACKUP_SET</code> .
S	The status of the backup: A (available), U (unavailable), or X (all backup pieces in set expired). Refer to the <a href="#">CHANGE</a> , <a href="#">CROSSCHECK</a> , and <a href="#">DELETE</a> commands for an explanation of each status.
#Pieces	The number of backup pieces in the backup set.
#Copies	The number of copies made of each backup piece in the set. The number is 1 if no duplexing was performed. Otherwise, the value ranges from 2 to 4.
Compressed	YES if the backup was compressed by RMAN; NO if not compressed by RMAN.
Tag	The tag applied to the backup set. Tag names are not case sensitive and appear in all uppercase.

**Table 2-21 List of Datafile Copies**

Column	Indicates
Key	<p>The unique identifier for the data file copy. Use this value in a <a href="#">CHANGE</a> command to alter the status of the data file copy.</p> <p>If RMAN is connected to a recovery catalog, then <i>Key</i> is the primary key of the data file copy in the catalog. It corresponds to <i>CDF_KEY</i> in the <i>RC_DATAFILE_COPY</i> view. If RMAN is connected in <i>NOCATALOG</i> mode, then <i>Key</i> displays the <i>RECID</i> from <i>V\$DATAFILE_COPY</i>.</p> <p><b>Note:</b> The values for <i>KEY</i> in the recovery catalog and the control file are different.</p>
File	The file number of the data file from which this copy was made.
S	The status of the copy: A (available), U (unavailable), or X (expired). Refer to the <a href="#">CHANGE</a> , <a href="#">CROSSCHECK</a> , and <a href="#">DELETE</a> commands for an explanation of each status.
Completion Time	The date and time that the copy completed. The value of this field is sensitive to the <i>NLS_LANG</i> and <i>NLS_DATE_FORMAT</i> environment variables.
Ckp SCN	The checkpoint of this data file when it was copied. All database changes prior to this SCN have been written to this data file.
Ckp TIME	The checkpoint of this data file when it was copied. All database changes prior to this time have been written to this data file.
Name	The file name of the data file copy.
Tag	The tag applied to the data file copy. Tag names are not case sensitive and appear in all uppercase.

**Table 2-22 List of Control File Copies**

Column	Indicates
Key	<p>The unique identifier for the control file copy. Use this value in a <a href="#">CHANGE</a> command to alter the status of the copy.</p> <p>If RMAN is connected to a recovery catalog, then <i>Key</i> is the primary key of the control file copy in the catalog. It corresponds to <i>CCF_KEY</i> in the <i>RC_CONTROLFILE_COPY</i> view. If RMAN is connected in <i>NOCATALOG</i> mode, then <i>Key</i> displays the <i>RECID</i> from <i>V\$DATAFILE_COPY</i>.</p> <p><b>Note:</b> The values for <i>Key</i> in the recovery catalog and the control file are different.</p>
S	The status of the copy: A (available), U (unavailable), or X (expired). Refer to the <a href="#">CHANGE</a> , <a href="#">CROSSCHECK</a> , and <a href="#">DELETE</a> commands for an explanation of each status.
Completion Time	The date and time that the copy completed. The value of this field is sensitive to the <i>NLS_LANG</i> and <i>NLS_DATE_FORMAT</i> environment variables.
Ckp SCN	The checkpoint of this control file when it was copied.
Ckp TIME	The checkpoint of this control file when it was copied.
Name	The file name of the control file copy.

**Table 2-22 (Cont.) List of Control File Copies**

Column	Indicates
Tag	The tag applied to the control file copy. Tag names are not case sensitive and appear in all uppercase.

**Table 2-23 List of Archived Log Copies**

Column	Indicates
Key	The unique identifier for this archived redo log copy. Use this value in a <a href="#">CHANGE</a> command to alter the status of the copy. If RMAN is connected to a recovery catalog, then <code>Key</code> is the primary key of the backup set in the catalog. It corresponds to <code>AL_KEY</code> in the <code>RC_ARCHIVED_LOG</code> view. If RMAN is connected in <code>NOCATALOG</code> mode, then <code>Key</code> displays the <code>RECID</code> from <code>V\$ARCHIVED_LOG</code> . <b>Note:</b> The values for <code>Key</code> in the recovery catalog and the control file are different.
Thrd	The redo log thread number.
Seq	The log sequence number.
S	The status of the copy: <code>A</code> (available), <code>U</code> (unavailable), or <code>X</code> (expired). Refer to the <a href="#">CHANGE</a> , <a href="#">CROSSCHECK</a> , and <a href="#">DELETE</a> commands for an explanation of each status.
Low Time	The time when the database switched into the redo log having this sequence number.
Name	The file name of the archived redo log copy.

**Table 2-24 List of Database Incarnations**

Column	Indicates
DB Key	When combined with the <code>Inc Key</code> , the unique key by which RMAN identifies the database incarnation in the recovery catalog. Use this key to unregister a database from a recovery catalog, that is, delete all the rows associated with that database from the recovery catalog.
Inc Key	When combined with <code>DB Key</code> , the unique key by which RMAN identifies the database incarnation in the recovery catalog. Use this key in <a href="#">RESET DATABASE TO INCARNATION</a> when recovering the database to a time before the most recent <code>RESETLOGS</code> .
DB Name	The database name as listed in the <code>DB_NAME</code> parameter.
DB ID	The database identification number, which the database generates automatically at database creation.
STATUS	<code>CURRENT</code> for the current incarnation, <code>PARENT</code> for the parent incarnations of the current incarnation, and <code>ORPHAN</code> for orphaned incarnations.
Reset SCN	The SCN at which the incarnation was created.
Reset Time	The time at which the incarnation was created.



**Table 2-25 List of Stored Scripts in the Recovery Catalog (LIST SCRIPT NAMES)**

Column	Indicates
Script Name	The name of the stored script.
Description	The comment provided when the script was created.

**Table 2-26 List of Restore Points (LIST RESTORE POINT)**

Column	Indicates
SCN	The SCN for the restore point.
RSP Time	The time specified in the <code>CREATE RESTORE POINT</code> statement; otherwise null.
Type	<code>GUARANTEED</code> if a guaranteed restore point; null if a normal restore point.
Time	The time that the restore point was created.
Name	The name of the restore point.

**Table 2-27 List of Failures**

Column	Indicates
Failure ID	The unique identifier for a failure.
Priority	<p>The priority of the failure: <code>CRITICAL</code>, <code>HIGH</code>, or <code>LOW</code>.</p> <p>Failures with <code>CRITICAL</code> priority require immediate attention because they make the whole database unavailable. Typically, critical failures bring down the instance and are diagnosed during the subsequent startup. The database is not available until all critical failures are fixed (see <a href="#">ADVISE FAILURE</a>).</p> <p>Failures with <code>HIGH</code> priority make a database partially unavailable or unrecoverable, and usually have to be repaired in a reasonably short time. Examples of such failures include physical data block corruptions, nonfatal I/O errors, missing archived redo log files or backup files, and so on.</p> <p>Failures with <code>LOW</code> priority can be ignored until more important failures are fixed. For example, a block corruption is initially assigned a high priority, but if this block is not important for the database availability, you can use <a href="#">CHANGE FAILURE</a> to change the priority to <code>LOW</code>.</p>
Status	The repair status of the failure. The status of a failure is <code>OPEN</code> (not repaired) until the appropriate repair action is invoked. The failure status changes to <code>CLOSED</code> when the repair is completed.
Time Detected	The date when the failure was diagnosed.
Summary	Summary of the failure.

 **Note:**

Starting in Oracle Database 19c, the Data Recovery Advisor (DRA) feature is deprecated.

The deprecation of DRA includes deprecation of the following Oracle Recovery Manager (RMAN) commands: `LIST FAILURE`, `ADVISE FAILURE`, `REPAIR FAILURE`, and `CHANGE FAILURE`. Database administrators will no longer have access to these commands. There is no replacement feature for DRA.

**Table 2-28 List of Databases (LIST DB\_UNIQUE\_NAME)**

Column	Indicates
DB Key	When combined with <code>Inc Key</code> , the unique key by which RMAN identifies the database incarnation in the recovery catalog. Primary and standby databases share the same <code>DB Key</code> value.
DB Name	The <code>DB_NAME</code> of the database. Primary and standby databases share the same <code>DB Name</code> value.
DB ID	The <code>DBID</code> of the database. Primary and standby databases share the same <code>DBID</code> .
Database Role	<code>PRIMARY</code> if the database is a primary database; <code>STANDBY</code> if it is a standby database.
<code>Db_unique_name</code>	The <code>DB_UNIQUE_NAME</code> of the database. Primary and standby databases have different <code>DB_UNIQUE_NAME</code> values.

## Examples

### Example 2-110 Listing Backups

This example lists all backups. The output shows two backup sets on disk: one containing data files and the other containing autobackups. The output also shows one SBT backup containing archived redo log files.

```
RMAN> LIST BACKUP;
```

```
List of Backup Sets
```

```
=====
```

```
BS Key   Type LV Size          Device Type Elapsed Time Completion Time
-----
200      Full  509.78M DISK          00:01:03    15-FEB-13
        BP Key: 202   Status: AVAILABLE Compressed: NO Tag: TAG20130215T171219
        Piece Name: /disk2/PROD/backupset/2013_02_15/o1_mf_nnndf_TAG20130215T171219_2xb17nbb_.bkp
List of Datafiles in backup set 200
File LV Type Ckp SCN    Ckp Time Name
-----
1      Full  421946  15-FEB-13 /disk1/oradata/prod/system01.dbf
2      Full  421946  15-FEB-13 /disk1/oradata/prod/sysaux01.dbf
3      Full  421946  15-FEB-13 /disk1/oradata/prod/undotbs01.dbf
4      Full  421946  15-FEB-13 /disk1/oradata/prod/cwmlite01.dbf
5      Full  421946  15-FEB-13 /disk1/oradata/prod/drsys01.dbf
6      Full  421946  15-FEB-13 /disk1/oradata/prod/example01.dbf
7      Full  421946  15-FEB-13 /disk1/oradata/prod/indx01.dbf
8      Full  421946  15-FEB-13 /disk1/oradata/prod/tools01.dbf
9      Full  421946  15-FEB-13 /disk1/oradata/prod/users01.dbf
```

```

BS Key  Type LV Size          Device Type Elapsed Time Completion Time
-----
201     Full  7.98M    DISK          00:00:03    15-FEB-13
        BP Key: 203   Status: AVAILABLE Compressed: NO   Tag: TAG20130215T171219
        Piece Name: /disk2/PROD/backupset/2013_02_15/
ol_mf_ncsnf_TAG20130215T171219_2xb19prg_.bkp
        SPFILE Included: Modification time: 15-FEB-13
        SPFILE db_unique_name: PROD
        Control File Included: Ckp SCN: 421968          Ckp time: 15-FEB-13

```

```

BS Key  Size          Device Type Elapsed Time Completion Time
-----
227     30.50M    SBT_TAPE   00:00:11    15-FEB-13
        BP Key: 230   Status: AVAILABLE Compressed: NO   Tag: TAG20130215T171334
        Handle: 0bia4rtv_1_1  Media:

```

## List of Archived Logs in backup set 227

Thrd	Seq	Low SCN	Low Time	Next SCN	Next Time
1	5	389156	15-FEB-13	411006	15-FEB-13
1	6	411006	15-FEB-13	412972	15-FEB-13
1	7	412972	15-FEB-13	417086	15-FEB-13
1	8	417086	15-FEB-13	417114	15-FEB-13
1	9	417114	15-FEB-13	417853	15-FEB-13
1	10	417853	15-FEB-13	421698	15-FEB-13
1	11	421698	15-FEB-13	421988	15-FEB-13

**Example 2-111 Listing a Summary of Backups**

This example summarizes the RMAN backups listed in [Example 2-110](#).

```
RMAN> LIST BACKUP SUMMARY;
```

## List of Backups

```

=====
Key      TY LV S Device Type Completion Time #Pieces #Copies Compressed Tag
-----
200     B F A DISK          15-FEB-13          1         1         NO   TAG20130215T171219
201     B F A DISK          15-FEB-13          1         1         NO   TAG20130215T171219
227     B A A SBT_TAPE     15-FEB-13          1         1         NO   TAG20130215T171334

```

**Example 2-112 Listing Backups by File**

This example groups all backups by file. The tag column of the data file backup indicates that one backup set contains backup pieces with different tags. The status column of the archived log backup indicates that the backup set is unavailable.

```
RMAN> LIST BACKUP BY FILE;
```

## List of Datafile Backups

```

=====
File Key      TY LV S Ckp SCN      Ckp Time #Pieces #Copies Compressed Tag
-----
1      329     B F A 454959     16-FEB-13 1         1         NO   DF1
2      349     B F A 454997     16-FEB-13 1         1         NO   DF2
3      527     B F A 455218     16-FEB-13 1         1         NO   FRI_BKP
        368     B F A 455022     16-FEB-13 1         1         NO   DF3
4      387     B F X 455042     16-FEB-13 1         1         NO   DF4
5      407     B F A 455063     16-FEB-13 1         1         NO   DF5
6      428     B F A 455083     16-FEB-13 1         2         NO   *
7      450     B F X 455103     16-FEB-13 1         1         NO   DF7
8      473     B F A 455123     16-FEB-13 1         1         NO   DF8
9      497     B F A 455143     16-FEB-13 1         1         NO   DF9

```

## List of Archived Log Backups

```

=====

```

Thrd	Seq	Low SCN	Low Time	BS Key	S	#Pieces	#Copies	Compressed	Tag
1	5	389156	15-FEB-13	227	U	1	1	NO	TAG20130215T171334
1	6	411006	15-FEB-13	227	U	1	1	NO	TAG20130215T171334
1	7	412972	15-FEB-13	227	U	1	1	NO	TAG20130215T171334
1	8	417086	15-FEB-13	227	U	1	1	NO	TAG20130215T171334
1	9	417114	15-FEB-13	227	U	1	1	NO	TAG20130215T171334
1	10	417853	15-FEB-13	227	U	1	1	NO	TAG20130215T171334
1	11	421698	15-FEB-13	227	U	1	1	NO	TAG20130215T171334

List of Control File Backups

=====

CF Ckp	SCN	Ckp Time	BS Key	S	#Pieces	#Copies	Compressed	Tag
454974	16-FEB-13	330	A	1	1	NO	DF1	
421968	15-FEB-13	201	A	1	1	NO	TAG20130215T171219	

List of SPFILE Backups

=====

Modification Time	BS Key	S	#Pieces	#Copies	Compressed	Tag
15-FEB-13	330	A	1	1	NO	DF1
15-FEB-13	201	A	1	1	NO	TAG20130215T171219

### Example 2-113 Listing Image Copies

The following example lists all data file, control file, and archived redo log copies known to RMAN:

RMAN> LIST COPY;

List of Datafile Copies

=====

Key	File S	Completion Time	Ckp SCN	Ckp Time
618	1	A 16-FEB-13	461057	16-FEB-13
Name: /disk2/PROD/datafile/o1_mf_system_2xdbrg13_.dbf				
Tag: TAG20130216T140706				
631	2	A 16-FEB-13	461163	16-FEB-13
Name: /disk2/PROD/datafile/o1_mf_sysaux_2xdbzybx_.dbf				
Tag: TAG20130216T141109				

List of Control File Copies

=====

Key	S	Completion Time	Ckp SCN	Ckp Time
619	A	16-FEB-13	461133	16-FEB-13
Name: /disk2/PROD/controlfile/o1_mf_TAG20130216T140706_2xdbz5tb_.ctl				
Tag: TAG20130216T140706				
594	A	16-FEB-13	460650	16-FEB-13
Name: /disk2/PROD/controlfile/o1_mf_TAG20130216T135954_2xdbbz99_.ctl				
Tag: TAG20130216T135954				

List of Archived Log Copies for database with db\_unique\_name PROD

=====

Key	Thrd	Seq	S	Low Time
105	1	5	A	15-FEB-13
Name: /disk1/oradata/prod/arch/archive1_5_614616887.dbf				
122	1	6	A	15-FEB-13
Name: /disk1/oradata/prod/arch/archive1_6_614616887.dbf				

```

123      1      7          A 15-FEB-13
        Name: /disk1/oradata/prod/arch/archive1_7_614616887.dbf

124      1      8          A 15-FEB-13
        Name: /disk1/oradata/prod/arch/archive1_8_614616887.dbf

125      1      9          A 15-FEB-13
        Name: /disk1/oradata/prod/arch/archive1_9_614616887.dbf

185      1     10          A 15-FEB-13
        Name: /disk1/oradata/prod/arch/archive1_10_614616887.dbf

221      1     11          A 15-FEB-13
        Name: /disk1/oradata/prod/arch/archive1_11_614616887.dbf

262      1     12          A 15-FEB-13
        Name: /disk1/oradata/prod/arch/archive1_12_614616887.dbf

263      1     13          A 15-FEB-13
        Name: /disk1/oradata/prod/arch/archive1_13_614616887.dbf

```

**Example 2-114 Listing Database Incarnations**

This example lists all database incarnations recorded in the recovery catalog.

```

RMAN> LIST INCARNATION;

```

```

List of Database Incarnations
DB Key  Inc Key DB Name  DB ID          STATUS  Reset SCN  Reset Time
-----
78      94      PROD    1619073740    PARENT  1          14-FEB-13
78      79      PROD    1619073740    CURRENT 388003     15-FEB-13

```

**Example 2-115 Listing Failures**

This example lists all failures regardless of their priority. If you do not specify ALL, then LIST FAILURE output does not include failures with LOW priority.

```

RMAN> LIST FAILURE ALL;

```

```

List of Database Failures
=====

Failure ID Priority Status   Time Detected Summary
-----
142      HIGH    OPEN    23-APR-13  One or more non-system datafiles are missing
101      HIGH    OPEN    23-APR-13  Datafile 1: '/disk1/oradata/prod/system01.dbf'
                                     contains one or more corrupt blocks

```

**Example 2-116 Listing Information About PDB Incarnations**

This example lists details about all the incarnations of PDB my\_pdb.

```

LIST INCARNATION OF PLUGGABLE DATABASE my_pdb;

```

## 2.28 PRINT SCRIPT

**Purpose**

Use the PRINT SCRIPT command to print a local or global stored script to standard output or to a file.

## Prerequisites

Execute `PRINT SCRIPT` only at the RMAN prompt. RMAN must be connected to a target database and a recovery catalog. The recovery catalog database must be open.

If the specified script is a local script, then RMAN must be connected to the target database that it was connected to when you created or replaced the script.

## Usage Notes

If `GLOBAL` is not specified, then RMAN looks for a local or global script `script_name` to print. If a local script is found, then it is printed. If no local script is found, but a global script `script_name` is found, then the global script is printed.

## Syntax

**`printScript::=`**

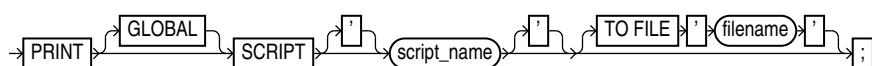

## Semantics

Syntax Element	Description
<code>GLOBAL</code>	Identifies the script as global. If <code>GLOBAL</code> is specified, then a global script with the specified name must exist in the recovery catalog. Otherwise, RMAN returns error <code>RMAN-06004</code> . <b>See Also:</b> " <a href="#">Usage Notes</a> " for an explanation of the difference between global and local scripts
<code>script_name</code>	Specifies the name of the script to print. Quotes must be used around the script name when the name contains either spaces or reserved words.
<code>TO FILE 'filename'</code>	Sends output to the specified file instead of standard output.

## Examples

### Example 2-117 Printing a Script to a File

This example prints a script to the file `/tmp/global_backup_db.rman`:

```
RMAN> PRINT GLOBAL SCRIPT global_backup_db TO FILE "/tmp/global_backup_db.rman";
```

### Example 2-118 Printing a Script to the Screen

This example prints a stored script to standard output (and includes sample output):

```
RMAN> PRINT SCRIPT backup_whole;

printing stored script: backup_whole
{
  BACKUP
    INCREMENTAL LEVEL 0 TAG backup_whole
    FORMAT "/disk2/backup/%U"
    DATABASE PLUS ARCHIVELOG;
}
```

## 2.29 QUIT

### Purpose

Use the `QUIT` command to shut down the Recovery Manager utility. This command is functionally equivalent to the `EXIT` command.

### Prerequisites

Execute only at the RMAN prompt.

### Syntax

***quit::=***

```
→ QUIT →
```

### Example

#### Example 2-119 Quitting RMAN

This example terminates RMAN (sample output included):

```
RMAN> QUIT
```

```
Recovery Manager complete.
```

# 3

## RMAN Commands: RECOVER to VALIDATE

This chapter describes RMAN commands in alphabetical order. For a summary of the RMAN commands and command-line options, refer to "[Summary of RMAN Commands](#)".

- RECOVER
- REGISTER DATABASE
- RELEASE CHANNEL
- REPAIR FAILURE
- REPLACE SCRIPT
- REPORT
- RESET DATABASE
- RESTORE
- RESYNC CATALOG
- REVOKE
- RMAN
- RUN
- SEND
- SET
- SHOW
- SHUTDOWN
- SPOOL
- SQL
- SQL (Quoted)
- STARTUP
- SWITCH
- TRANSPORT TABLESPACE
- UNREGISTER
- UPGRADE CATALOG
- VALIDATE



 **Note:**

A multitenant container database is the only supported architecture in Oracle Database 21c. While the documentation is being revised, legacy terminology may persist. In most cases, "database" and "non-CDB" refer to a CDB or PDB, depending on context. In some contexts, such as upgrades, "non-CDB" refers to a non-CDB from a previous release.

## 3.1 RECOVER

### Purpose

Use the `RECOVER` command to perform one of the following distinct tasks:

- Perform complete recovery of a whole multitenant container database (CDB), the root, one or more pluggable databases (PDBs), one or more tablespaces, or one or more restored data files
- Perform point-in-time recovery of a whole multitenant container database (CDB), one or more pluggable databases (PDBs), one or more tablespaces, tables, or table partitions
- Apply incremental backups to a data file image copy (*not* a restored data file) to roll it forward in time
- Recover a corrupt data block or set of data blocks within a data file

 **See Also:**

*Oracle Database Backup and Recovery User's Guide* to learn how to recover data files

### Prerequisites

All redo or incremental changes required for the recovery must exist on disk or in SBT. If RMAN needs to restore incremental backups or archived redo log files during recovery, then you must either have automatic channels configured or manually allocate channels of the same type that created these backups.

If you perform media recovery on an encrypted database or tablespace, then the Oracle keystore must be open when performing media recovery. See *Oracle Database Administrator's Guide* to learn about encrypted tablespaces.

To perform recovery in a destination CDB using preplugin backups, the root must be open and you must connect to the root as a common user with the `SYSDBA` or `SYSBACKUP` privilege.

In a CDB that uses shared undo, to perform point-in-time recovery of one or more PDBs, backups of the root and the seed database of the CDB that contains the listed PDBs must be available.

To perform TSPITR of tablespaces in a PDB, backups of the root and the seed database (PDB\$SEED) of the CDB that contains the PDBs must be available.

### Prerequisites Specific to RECOVER BLOCK

The following prerequisites apply to `RECOVER BLOCK`:

- The target database must run in `ARCHIVELOG` mode and be open or mounted with a current control file.
- RMAN can only recover blocks marked media corrupt. The `V$DATABASE_BLOCK_CORRUPTION` view indicates which blocks in a file were marked corrupt since the most recent `BACKUP` or `BACKUP ... VALIDATE` command was run against the file.
- The backups of the data files containing the corrupt blocks must be full backups and not proxy backups. If only proxy backups exist, then you can restore them to a nondefault location on disk, in which case RMAN considers them data file copies. You can then use the data file copies for block media recovery.
- RMAN can use only archived redo log files for recovery. Block media recovery cannot survive a missing or inaccessible log, although it can sometimes survive missing or inaccessible records (see *Oracle Database Backup and Recovery User's Guide*).
- For RMAN to be able to search the flashback logs for good copies of corrupt blocks, Flashback Database must be enabled on the target database.
- For RMAN to be able to search a standby database for good copies of corrupt blocks, the target database must be associated with a physical standby database in a Data Guard environment. In addition, the physical standby database must be open read-only in managed recovery.



#### Note:

An active Data Guard license is required for this operation.

### Usage Notes

By default, RMAN performs complete recovery. For point-in-time recovery, the best practice is to enter a `SET UNTIL` command before both the `RESTORE` and `RECOVER` commands in a `RUN` command so that the `UNTIL` time applies to both commands. If you run `SET UNTIL` after restoring the database, then you may not be able to recover the database to the target time because the restored files may have timestamps later than the target time.



#### Note:

You must open the database with the `RESETLOGS` option after incomplete recovery or recovery with a backup control file.

RMAN enables you to recover a whole multitenant container database (CDB), the root, one or more PDBs, and tablespaces in a root or PDB. You can perform complete recovery or point-in-time recovery for PDBs and CDBs. However, you cannot recover the root to a specified point in time.

To recover the whole CDB, the root, or multiple PDBs, you connect to the root. To recover a particular PDB, connect to that PDB. To recover PDBs, you use the `RECOVER PLUGGABLE DATABASE` command. To recover a whole CDB, use the `RECOVER DATABASE` command and to recover the root, use the `RECOVER DATABASE ROOT` command.

 **See Also:**

*Oracle Database Backup and Recovery User's Guide* for information about performing recovery of CDBs PDBs

In a Data Guard environment, you may need to restore the entire CDB after the point-in-time recovery of a primary database, for the standby database to follow the primary database.

### Incremental Backups and Archived Redo Log Files

Except for `RECOVER BLOCK`, RMAN can use both incremental backups and archived redo log files for recovery. RMAN uses the following search order:

1. Incremental backup sets on disk or tape
2. Archived redo log files on disk
3. Archived redo log backups on disk
4. Archived redo log backup sets on tape

When RMAN chooses a destination to restore archived redo log files, it uses the following order of precedence:

1. `SET ARCHIVELOG DESTINATION`
2. The `LOG_ARCHIVE_DEST_n` parameter whose value is set to `LOCATION=USE_DB_RECOVERY_FILE_DEST`
3. `LOG_ARCHIVE_DEST_1`

RMAN can apply incremental backups to data files that were not restored from an incremental backup. If overlapping levels of incremental backup exist, then RMAN automatically chooses the level covering the longest period of time.

### Recovery Using Storage Snapshots

Storage Snapshot Optimization enables you to use third-party technologies to take storage snapshots without putting the database or associated data files in `BACKUP` mode. When recovering the database using a storage snapshot, specify the `SNAPSHOT TIME` option.

 **See Also:**

*Oracle Database Backup and Recovery User's Guide* for information about specifying the snapshot time

To be usable in recovery operations, the snapshots must conform to the following requirements. Ask your vendor for a guarantee of compliance.

- The database is crash consistent during the snapshot.
- The snapshot preserves write order for each file.
- The snapshot technology stores the time at which the snapshot is completed.

#### **Caution:**

Take care that the database snapshots are usable. Oracle Database does not use a snapshot for recovery if structural changes were made during the snapshot. Some SQL operations can make database structural changes and should not be used during a snapshot. A few examples of such operations include the `OFFLINE`, `ONLINE`, `READONLY`, `DROP`, `RENAME`, `SHRINK`, and `ADD` clauses.

#### **See Also:**

`ALTER DATABASE` and `ALTER TABLESPACE` commands in *Oracle Database SQL Language Reference* for information about clauses that make database structural changes

## Recovery Through RESETLOGS

You must [RESTORE](#) data files before you can recover them. RMAN can recover through `RESETLOGS` operations transparently if the data files to be recovered are from a parent incarnation. If required, the `RECOVER` command can also restore and apply archived redo log files and incremental backups from previous database incarnations, even if those logs were generated in previous releases of Oracle Database.

When recovering through an `OPEN RESETLOGS`, ensure that you have all logs needed for recovery. In a previous database incarnation, you must have the logs from the time of the backup until the SCN that is 1 less than the `RESETLOGS SCN`. The incarnation table must have a complete history of `RESETLOGS` operations from the creation time of the database backup. If the complete metadata is not found in `V$DATABASE_INCARNATION`, then you can re-create this metadata by using [CATALOG](#) for the archived redo log files from the missing incarnations.

#### **See Also:**

[RESTORE](#) command for explanation of the default location for restoring archived redo log files. RMAN automatically specifies the `MAXSIZE` option when staging logs in the fast recovery area.

## Recovery of Sparse Databases

RMAN also enables you to perform point-in-time recovery for sparse databases when the `COMPATIBLE` initialization parameter is set to 12.2 or higher. For complete recovery, RMAN recovers data files by applying archived redo log files and online redo logs. Therefore, the `FROM SPARSE` and `FROM NONSPARSE` clauses are not applicable to complete recovery. For point-

in-time recovery, RMAN first restores data files and then recovers them, and therefore, the FROM SPARSE and FROM NONSPARSE clauses are applicable to PITR.

### Syntax

**recover::=**

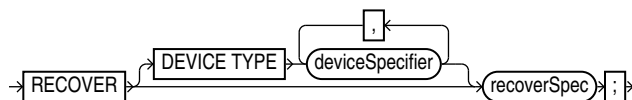

(deviceSpecifier::=, recoverObject::=, recoverOptionList::=)

**recoverSpec::=**

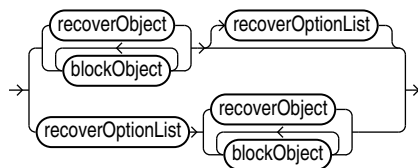

(recoverObject::=, blockObject::=, recoverOptionList::=)

**recoverObject::=**

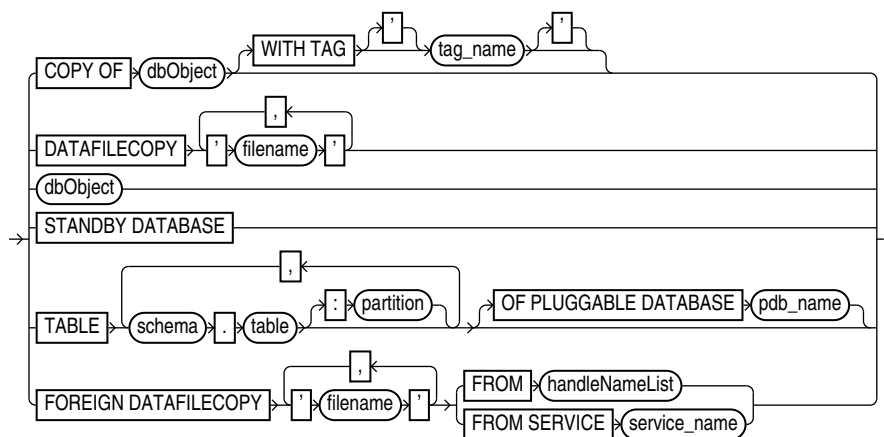

(dbObject, untilClause::=)

**dbObject::=**

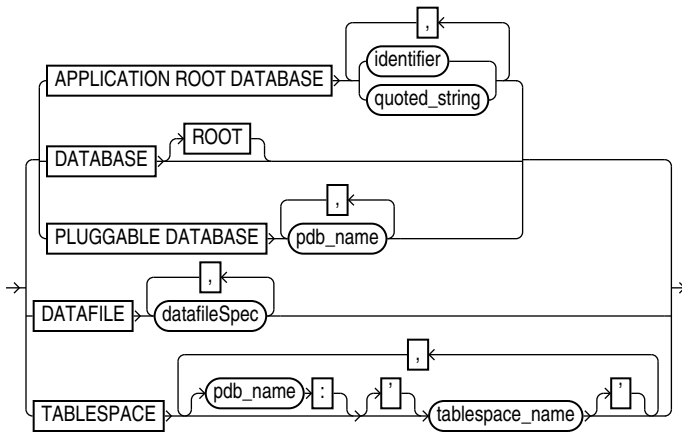

**blockObject ::=**

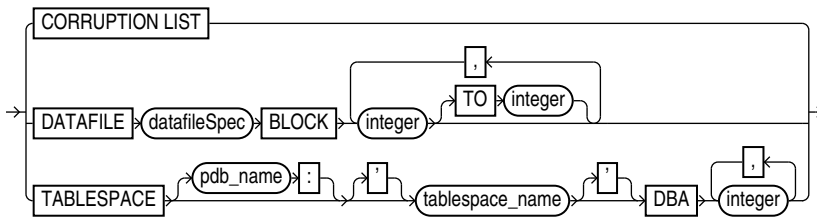

**(datafileSpec ::=)**

**recoverOptionList ::=**

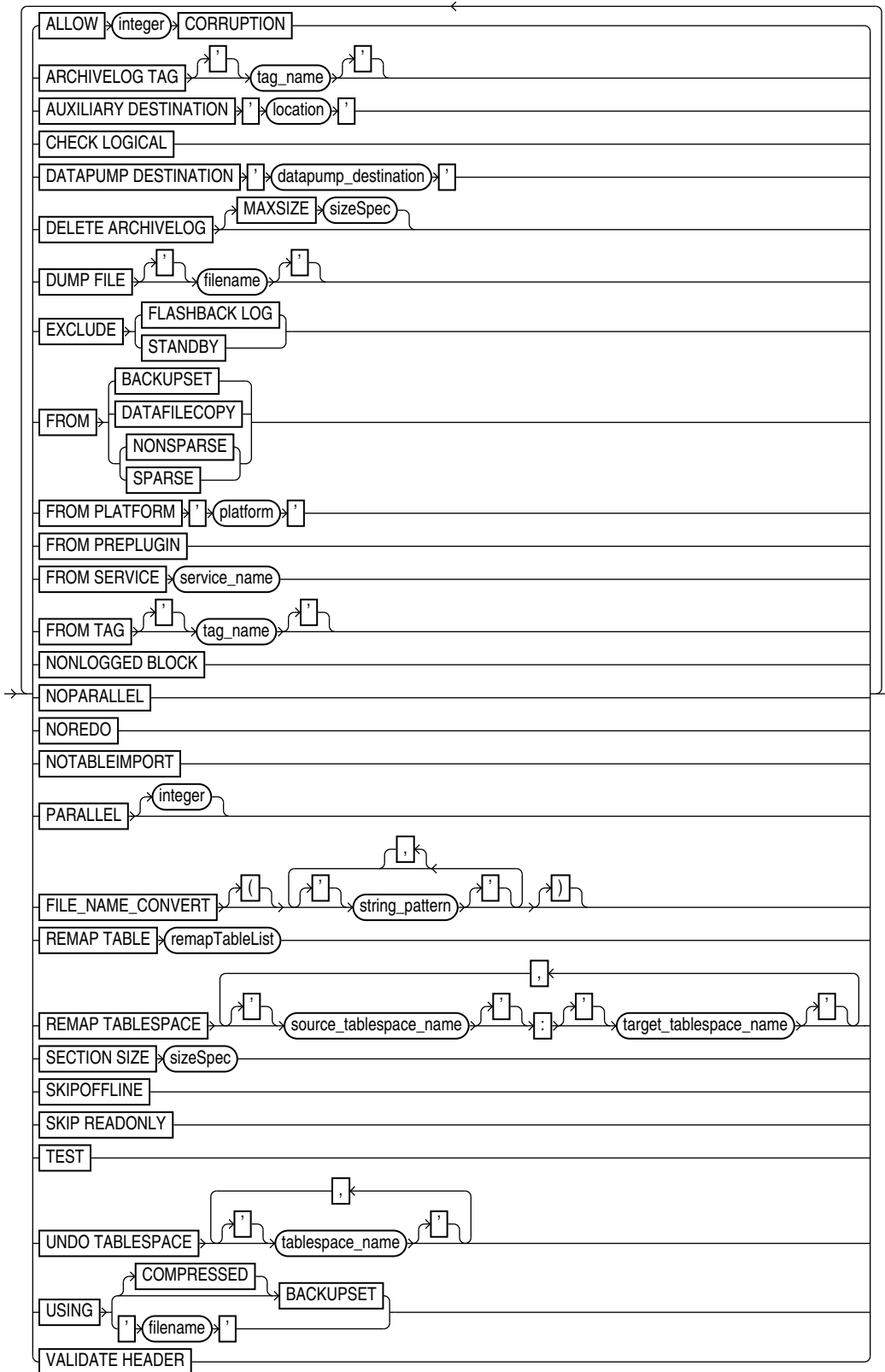

(*remapTableList::=*, *sizeSpec::=*)

***remapTableList::=***

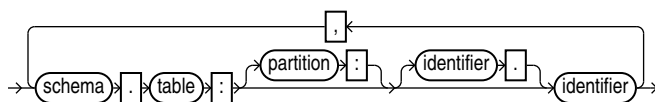

## Semantics

### *recover*

Syntax Element	Description
DEVICE TYPE <a href="#">deviceSpecifier</a>	<p>Allocates automatic channels for the specified device type only. For example, if you configure automatic disk and tape channels, and if you issue <code>RECOVER DEVICE TYPE DISK</code>, then RMAN allocates only disk channels.</p> <p>You configure a device type with the <code>CONFIGURE DEVICE TYPE</code> command (except for <code>DISK</code>, which is preconfigured) before specifying the <code>DEVICE TYPE</code> option.</p> <p><b>Note:</b> You cannot manually allocate channels and then run <code>RECOVER DEVICE TYPE</code>.</p> <p><b>See Also:</b> <a href="#">deviceSpecifier</a></p>
<a href="#">recoverSpec</a>	Specifies the type of object being recovered.

### *recoverSpec*

Syntax Element	Description
<a href="#">recoverObject</a>	Specifies the type of object being recovered.
<a href="#">blockObject</a>	Specifies the blocks to be recovered with block media recovery.
<a href="#">recoverOptionList</a>	Specifies recovery options.

### *recoverObject*

This subclause specifies which files to recover. Refer to [recoverObject::=](#) for the syntax diagram.

Syntax Element	Description
COPY OF <a href="#">dbObject</a>	<p>Applies incremental backups to the specified image copy to roll it forward to any time equal to or before the most recent incremental backup of the file. The existing image copy is overwritten and remains in a fuzzy state during the recovery. RMAN makes an autobackup after recovering the image copy.</p> <p>This command updates a data file copy and is <i>not</i> a media recovery of a current database file. This command is meant to be used with the <code>BACKUP . . . FOR RECOVER OF COPY</code> syntax to implement a strategy using incrementally updated backups.</p> <p>The following requirements must be met:</p> <ul style="list-style-type: none"> <li>• At least one copy of each data file that you are recovering must exist.</li> <li>• Incremental backups taken after the image copy that you are recovering must exist.</li> </ul> <p>RMAN selects one suitable copy if there are multiple possible copies to which the incremental backups can be applied to carry out the operation.</p> <p><b>Note:</b> RMAN issues a warning (not an error) if it cannot recover to the specified time because no incremental backups are available.</p>



Syntax Element	Description
WITH TAG <i>tag_name</i>	Specifies a tag name to identify the image copy to be rolled forward.
DATAFILECOPY ' <i>filename</i> '	Applies incremental backups to the specified data file image copy (see <a href="#">Example 3-4</a> ). Refer to description of RECOVER COPY OF.
<b>dbObject</b>	Specifies the data blocks that require recovery.
STANDBY DATABASE	Applies incremental backups, rolls forward, and then restarts the physical standby database.  Use the FROM SERVICE clause to specify the primary database required to refresh the standby database. First, connect to the physical standby database as target, and then specify the net service name of the primary database using the FROM SERVICE clause.  <b>Note:</b> PFILE and FROM SERVICE are the only allowed options for the STANDBY DATABASE clause.
FOREIGN DATAFILECOPY ' <i>filename</i> '	Specifies the names of the foreign data file copies that need to be made consistent by applying an incremental backup. These foreign data file copies were created during an inconsistent cross-platform backup by using either the CONVERT or BACKUP command with the ALLOW INCONSISTENT clause.
FROM BACKUPSET ' <i>filename</i> '	Specifies the name of the backup set containing the cross-platform incremental backup that must be applied to the foreign data file copies specified using the FOREIGN DATAFILECOPY ' <i>filename</i> ' clause.  The following conditions must be satisfied for a cross-platform incremental backup to be applied: <ul style="list-style-type: none"> <li>• The start SCN of each data file in the cross-platform incremental backup must be less than the current checkpoint SCN of the foreign data file copy.</li> <li>• The foreign data file copy must not be modified.</li> </ul> For example, it should not have been plugged in to the target database, changed to read-write mode, and then changed back to read-only mode. This changes the database ID and file number in the foreign data file copy header.  If these conditions are not met, an error occurs and the cross-platform incremental backup is not applied to the foreign data file copies.  <b>Note:</b> You cannot apply an incremental backup consisting of multiple backup sets to a set of foreign data files.
TABLE <i>schema.table[:partition]</i>	Specifies the tables or table partitions that must be recovered. The target database must be in read-write mode.  Before performing the recovery, RMAN checks if there is sufficient space on the target host to store files for the auxiliary instance that is used during recovery. If sufficient space does not exist, then RMAN displays an error message and exits. You can assign new names for recovered tables or table partitions in the target database by using the REMAP TABLE option.  When the recovered tables are imported into the target database, if a table with the same name exists in the target database, an error message is displayed indicating that the REMAP TABLE clause must be used to rename the tables.  When you recover only certain partitions from a partitioned table, each partition is imported into the target database as separate table. If REMAP TABLE is not used to rename recovered objects, RMAN names each table by using a concatenation of the table name and partition name. The table names of the recovered objects are in the format <i>tablename_partitionname</i> . If a table with this name exists in the target database, RMAN appends <i>_1</i> to the generated table name. If a table with this name too exists, RMAN appends <i>_2</i> to the table name, and so on.  See <a href="#">Example 3-8</a>

Syntax Element	Description
OF PLUGGABLE DATABASE <i>pdb_name</i>	In a CDB, the name of a PDB in which the table or table partition that must be recovered resides. To recover tables or table partitions in a PDB, you must connect to the root.
SKIP	Takes the data files in the specified tablespaces offline before starting media recovery. These files are left offline after the media recovery is complete. This option is useful for avoiding recovery of tablespaces containing only temporary data or for postponing recovery of some tablespaces.
FOREVER	Takes the data files offline with the DROP option (see <a href="#">Example 3-3</a> ). Use SKIP FOREVER TABLESPACE when you intend to drop the specified tablespaces after opening the database with the RESETLOGS option. <b>Note:</b> If you perform incomplete recovery, then SKIP requires the FOREVER option.
TABLESPACE <i>tablespace_name</i>	Specifies the name of the tablespace to take offline.
TABLESPACE <i>pdb_name:tablespace_name</i>	The name of a tablespace in a PDB.
SNAPSHOT TIME ' <i>date_string</i> '	Specifies time-based recovery from a snapshot backup that was created using Storage Snapshot Optimization. <i>date_string</i> is the time at which the snapshot was completed and is specified in RMAN TIME format (defined by NLS_DATE_FORMAT environment variable). You can combine SNAPSHOT TIME with UNTIL TIME or UNTIL SCN to do a database point-in-time recovery (DBPITR). However, you can only do a DBPITR to a time or an SCN greater than specified snapshot completion time. <b>See Also:</b> " <a href="#">Recovery Using Storage Snapshots</a> " for information about the requirements of the snapshot system and how to specify the snapshot time.
TO RESTORE POINT <i>restore_point_name</i>	Specifies a restore point for termination of the RECOVER command, with the SCN at which the restore point was created as the upper, inclusive limit. Because the limit is inclusive, RMAN selects only files that it can use to recover up to <i>and including</i> the SCN corresponding to the restore point.
<a href="#">untilClause</a>	Specifies a past time, SCN, or log sequence number for termination of the RECOVER command. When used with one or more tablespaces, the clause indicates a tablespace point-in-time recovery (TSPITR) operation for the named tablespaces. Do not use this clause with RECOVER DATAFILE or for RECOVER DATABASE (see " <a href="#">Usage Notes</a> "). After database point-in-time recovery (DBPITR), you must open the database with the RESETLOGS option. <b>See Also:</b> <a href="#">untilClause</a>
UNTIL AVAILABLE REDO	Finds the last available archived redo log and online redo logs, and recovers the database to the point where a log is missing. You can use this option only while performing recovery for a whole database. You cannot recover a data file, tablespace, or PDB using the UNTIL AVAILABLE REDO option. To perform point-in-time recovery for a PDB, you must specify the SCN for recovery.

**dbObject**

This subclause specifies whether to recover the database or a subset of the database. Refer to [dbObject::=](#) for the syntax diagram.

---

Syntax Element	Description
APPLICATION ROOT DATABASE	<p>Specifies all data files in the application root.</p> <p>Connect to the CDB root as a common user with the <code>SYSDBA</code> or <code>SYSBACKUP</code> privilege. Or, connect to application root as an application common user with the <code>SYSDBA</code> or <code>SYSBACKUP</code> privilege.</p>
DATABASE	<p>Specifies the entire database CDB. To recover the entire CDB, you must connect to the root as a common user with the <code>SYSDBA</code> or <code>SYSBACKUP</code> privilege.</p> <p>In an application container, recovers the entire application container to the specified point in time. This includes the application root and all application PDBs that belong to this application root. You connect to the application root as an application common user with the <code>SYSDBA</code> or <code>SYSBACKUP</code> privilege.</p> <p>By default, the <code>RECOVER DATABASE</code> command does not recover files that are offline normal at the point in time to which the files are being recovered. <code>RMAN</code> omits offline normal files with no further checking.</p> <p>When recovering after the loss of control files, <code>RMAN</code> automatically updates the control file to point to the actual location of the data files on disk (see <a href="#">Example 3-5</a>).</p> <p>If <code>RMAN</code> encounters redo for adding a data file, then <code>RMAN</code> automatically creates a new data file unless the tablespace containing the added data file is skipped during recovery. This situation can arise when a backup control file is restored before recovery and the backup control file does not contain a record of the recently-added data file.</p>
DATABASE ROOT	<p>Specifies only the root in a CDB. Connect to the root as a common user with the <code>SYSDBA</code> or <code>SYSBACKUP</code> privilege.</p> <p>In an application container, recovers online data files belonging to the application root and all the application PDBs. Connect to the application root as an application common user with the <code>SYSDBA</code> or <code>SYSBACKUP</code> privilege.</p>
PLUGGABLE DATABASE <i>pdb_name</i>	<p>Specifies one or more PDBs in a CDB. No other PDBs are affected; they can remain open and operational. Use a comma-delimited list to specify multiple PDBs. To recover multiple PDBs, connect to the root as a common user with the <code>SYSDBA</code> or <code>SYSBACKUP</code> privilege. To perform complete recovery of a particular PDB, connect to the PDB as a common user or local user with the <code>SYSDBA</code> or <code>SYSBACKUP</code> privilege.</p> <p>You must connect to the root, as a common user with the <code>SYSDBA</code> or <code>SYSBACKUP</code> privileges, to perform any of the following operations for PDBs: point-in-time recovery, table recovery, TSPITR, or duplication.</p> <p>In an application container, connect to the CDB root as a common user with the <code>SYSDBA</code> or <code>SYSBACKUP</code> privilege and specify the name of the application root in <i>pdb_name</i> to recover the application root and all application PDBs.</p> <p>To recover an application PDB, connect to the application root as an application common user with the <code>SYSDBA</code> or <code>SYSBACKUP</code> privilege. To recover multiple application PDBs, specify a common-separated list of application PDB names.</p>

---

Syntax Element	Description
DATAFILE <a href="#">datafileSpec</a>	<p>Specifies a list of one or more data files by either file name or absolute data file number.</p> <p>The target database must be mounted or open. If the database is open, then the data files to be recovered must be offline.</p> <p>If you are not using a recovery catalog, then the file name must be the name of the data file as recorded in the control file. If you are using a recovery catalog, then the file name of the data file must be the most recent name recorded in the catalog, even if the name in the control file has been updated more recently. For example, assume that a data file was renamed in the control file, but the instance fails before you resynchronize the catalog. Specify the old name of the data file in the <a href="#">RECOVER</a> command because this is the name recorded in the catalog.</p> <p><b>Note:</b> You cannot arbitrarily recover individual data files to different points in time, although you can recover the whole database to a single point in time or recover wholly contained tablespaces to a point in time different from the rest of the database (TSPITR). For more information on TSPITR, see the procedure described in <i>Oracle Database Backup and Recovery User's Guide</i>.</p> <p><b>See Also:</b> <a href="#">datafileSpec</a></p>
TABLESPACE <i>tablespace_name</i>	<p>Specifies a list of one or more tablespaces. The target database must be mounted or open. If the database is open, then the tablespaces to be recovered must be offline.</p> <p>When connected to the root, specifies the tablespaces in the root container. Specifies the names of tablespaces in a PDB when connected to a PDB.</p> <p><b>Note:</b> If the RMAN encounters redo for adding a data file, then RMAN automatically creates a new data file. This situation can arise when a backup control file is restored before recovery and the backup control file does not contain a record of the recently-added data file.</p>
TABLESPACE <i>pdb-name:tablespace_name</i>	<p>The name of the tablespace in a PDB. Multiple PDBs can have tablespaces with the same name. A qualifier before the name uniquely identifies the tablespace. This syntax is needed only when connected to the root. When connected directly to a PDB, use <code>TABLESPACE tablespace_name.pdb-name</code> is the name of a PDB.</p> <p>See the previous description for <code>TABLESPACE</code> for general information.</p>

### **blockObject**

This subclause specifies the data blocks that require recovery. Refer to [blockObject::=](#) for the syntax diagram. Refer to "[Prerequisites Specific to RECOVER BLOCK](#)" for prerequisites specific to block media recovery.

You can either use `RECOVER CORRUPTION LIST` to recover all blocks reported in the `V$DATABASE_BLOCK_CORRUPTION` view, or specify the data file number and block number or the tablespace and data block address (DBA). RMAN can only perform complete recovery of individual blocks.

By default, if Flashback Database is enabled, then RMAN searches the flashback logs for good copies of corrupt blocks. By default, if the target database exists in a Data Guard environment, then `RECOVER BLOCK` command can automatically retrieve blocks from a physical standby database to a primary database and vice-versa.

Syntax Element	Description
CORRUPTION LIST	<p>Recovers all physically corrupt blocks listed in the <code>V\$DATABASE_BLOCK_CORRUPTION</code> view. Block media recovery may not be able to repair all listed logically corrupt blocks. In these cases, alternate recovery methods, such as tablespace point-in-time recovery, or dropping and recreating the affected objects, may repair the corruption.</p> <p>The <code>V\$DATABASE_BLOCK_CORRUPTION</code> view displays blocks marked corrupt by Oracle Database components such as RMAN commands, <code>ANALYZE</code>, <code>SQL</code> queries, and so on. In short, any process that encounters an <code>ORA-1578</code> error records the block corruption in this view. The following types of corruption result in rows added to this view:</p> <ul style="list-style-type: none"> <li>Physical corruption (sometimes called media corruption). The database does not recognize the block at all: the checksum is invalid, the block contains all zeros, or the header and footer of the block do not match.</li> <li>Logical corruption. The block has a valid checksum, the header and footer match, and so forth, but the contents are logically inconsistent.</li> </ul> <p>The view does not record corruptions that can be detected by validating relationships between blocks and segments, but cannot be detected by a check of an individual block.</p> <p><b>Note:</b> Any RMAN command that fixes or detects that a block is repaired updates <code>V\$DATABASE_BLOCK_CORRUPTION</code>. For example, RMAN updates the repository at the end of successful block media recovery. If a <code>BACKUP</code>, <code>RESTORE</code>, or <code>VALIDATE</code> command detects that a block is no longer corrupted, then it removes the repaired block from the view.</p>
DATAFILE <a href="#">datafileSpec</a> BLOCK <i>integer</i> TO <i>integer</i>	<p>Recovers an individual data block or set of data blocks within a data file. It can copy blocks from either a standby or a primary database. The <code>TO</code> range is inclusive, so that <code>BLOCK 10 TO BLOCK 20</code> includes both block 10 and block 20.</p> <p>Block media recovery is useful when the data loss or corruption applies to a small number of blocks rather than to an entire data file. Typically, block corruption is reported in error messages in trace files or by the <code>ADVISE FAILURE</code> command. Block-level data loss usually results from:</p> <ul style="list-style-type: none"> <li>I/O errors causing minor data loss</li> <li>Memory corruptions that get written to disk</li> </ul> <p>If you do not specify an option from <a href="#">recoverOptionList</a>, and if Flashback Database is enabled on the database, then <code>RECOVER BLOCK</code> first searches the flashback logs and then the backups for a good version of the block to restore.</p> <p>Blocks marked media corrupt are not accessible until recovery completes.</p> <p><b>Note:</b> You can only perform complete recovery of individual blocks. In other words, you cannot stop recovery before all redo has been applied to the block.</p> <p><b>See Also:</b> <a href="#">datafileSpec</a></p>
TABLESPACE <i>tablespace_name</i> DBA <i>integer</i>	<p>Specifies the tablespace name or number containing the corrupt blocks and the data block address (DBA) of the corrupt block. You can only perform block media recovery on corrupt blocks.</p> <p><b>Note:</b> The data file header block (block 1) cannot be recovered.</p>
TABLESPACE <i>pdb-</i> <i>name:tablespace_name</i> DBA <i>integer</i>	<p>The name of the tablespace in a PDB. Multiple PDBs can have tablespaces with the same name. A qualifier before the name uniquely identifies the tablespace. <i>pdb-name</i> is the name of a PDB.</p> <p>See the previous description of <code>TABLESPACE</code> for general information.</p>

### ***recoverOptionList***

This subclause specifies various recovery options. Refer to [recoverOptionList::=](#) for the syntax diagram.

Syntax Element	Description
ALLOW <i>integer</i> CORRUPTION	Specifies the number of corrupt blocks that can be tolerated while allowing recovery to proceed. You can set this parameter in case of redo log corruption.
ARCHIVELOG TAG <i>tag_name</i>	Specifies the tag for an archived log backup to be used during recovery. Tag names are not case sensitive and display in all uppercase. If the tagged backup does not contain all the necessary archived redo log files for recovery, then RMAN uses logs or incremental backups as needed from whatever is available.
AUXILIARY DESTINATION ' <i>location</i> '	<p>Specifies a location where auxiliary set data files, control files, and online redo logs are created during TSPITR if another location for an individual file is not explicitly specified.</p> <p>If you do not specify AUXILIARY DESTINATION for a TSPITR, then you must specify the naming of individual auxiliary set data files, control files, and online redo logs before executing RECOVER TABLESPACE with the UNTIL clause. Otherwise, TSPITR fails.</p> <p>While performing point-in-time recovery of PDBs, if no auxiliary destination is specified, then the fast recovery area is used as the auxiliary destination. When an auxiliary destination is not specified and a fast recovery area is not configured, the recovery of the PDB fails.</p> <p><b>See also:</b> The chapter on TSPITR in <i>Oracle Database Backup and Recovery User's Guide</i> for more details about the auxiliary destination</p>
CHECK LOGICAL	<p>Tests data and index blocks that pass physical corruption checks for logical corruption, for example, corruption of a row piece or index entry. If RMAN finds logical corruption, then it logs the block in the <code>alert.log</code> and server session trace file.</p> <p>The SET MAXCORRUPT setting represents the total number of physical and logical corruptions permitted on a file. By default, MAXCORRUPT is 0, so that if any corrupt blocks exist, media recovery fails. If recovery including corrupt blocks is permissible, then set MAXCORRUPT to the smallest number of corrupt blocks that causes media recovery to fail. For example, to tolerate one corrupt block, set MAXCORRUPT to 1.</p> <p>If the total number of physical and logical corruptions detected for a file is less than its MAXCORRUPT setting, then the RMAN command completes and the database populates V\$DATABASE_BLOCK_CORRUPTION with corrupt block ranges. Otherwise, the command terminates without populating V\$DATABASE_BLOCK_CORRUPTION.</p>
DATAPUMP DESTINATION ' <i>datapump_destination</i> '	<p>Specifies the location of the Data Pump export dump file that contains the tables or table partitions that are recovered from an RMAN backup.</p> <p>If you do not specify a Data Pump destination, RMAN creates the export dump file in the destination indicated by AUXILIARY DESTINATION. If no auxiliary destination is specified, RMAN creates the dump file in a default operating system-specific location. On Linux, the default location is <code>\$ORACLE_HOME/dbs</code>. On Windows the default location is <code>%ORACLE_HOME%\database</code>.</p>
DELETE ARCHIVELOG	<p>Deletes archived redo log files restored from backups or copies that are no longer needed. RMAN does not delete archived redo log files that were on disk before the RESTORE command started. If you do not specify MAXSIZE, then RMAN deletes restored archived redo log files as they are applied.</p> <p><b>Note:</b> If archived redo log files are restored to the fast recovery area, then the DELETE ARCHIVELOG option is enabled by default.</p>

Syntax Element	Description
<code>MAXSIZE sizeSpec</code>	<p>Does not use more than <i>sizeSpec</i> amount of disk space for restored archived redo log files. If recovery requires the restore of a log larger than the <code>MAXSIZE</code> value, then RMAN reports an error indicating that you must increase the <code>MAXSIZE</code> value. If <code>MAXSIZE</code> is smaller than the backup set containing the logs, then RMAN must read the backup set more than once to extract the logs. In this situation, RMAN issues a warning to increase <code>MAXSIZE</code>.</p> <p><b>Note:</b> To conserve space during tablespace recovery, consider using the <code>DELETE ARCHIVELOG</code> option and the <code>MAXSIZE</code> option. This approach may help to avoid recovery failure caused due to space constraints, but may increase the potential recovery time.</p> <p>This example recovers a tablespace <code>users</code> and allocates 100K disk space for archived redo log files. If recovery requires the restore of a log larger than 100K, then RMAN reports an error indicating that you must increase the <code>MAXSIZE</code> value.</p> <pre>RECOVER TABLESPACE users DELETE ARCHIVELOG MAXSIZE 100K;</pre>
<code>DUMP FILE 'filename'</code>	<p>Specifies the name of the Data Pump export dump file that contains the recovered tables or table partitions. If you do not specify a name for the dump file, RMAN assigns a default name based on the operating system of the target database. The default name is <code>tsplitr_SID-of-clone_n.dmp</code> where <code>SID-of-clone</code> is the Oracle SID of the auxiliary database used by RMAN for recovery and <code>n</code> is a randomly-generated number. The dump file is created in the location specified by <code>DATAPUMP DESTINATION</code>.</p> <p>If <code>DATAPUMP DESTINATION</code> contains a file with the name specified in <code>DUMP FILE</code>, the recovery process fails.</p> <p><b>See Also:</b> <a href="#">DATAPUMP DESTINATION</a></p>
<code>EXCLUDE FLASHBACK LOG</code>	<p>Does not search the flashback logs for blocks to restore. By default, RMAN searches the flashback logs if Flashback Database is enabled.</p>
<code>EXCLUDE STANDBY</code>	<p>Does not search a physical standby database for blocks to restore. By default, in a Data Guard environment RMAN searches the blocks from a physical standby database.</p>
<code>FROM BACKUPSET</code>	<p>Specifies that only backup sets are restored. This clause is supported only while performing block media recovery. The <code>RECOVER . . . BLOCK</code> command is used to perform block media recovery.</p>
<code>FROM DATAFILECOPY</code>	<p>Restores only data file image copies.</p> <p>This clause is supported only while performing block media recovery. The <code>RECOVER . . . BLOCK</code> command is used to perform block media recovery.</p>
<code>FROM SPARSE</code>	<p>Recovers data files from archive logs and redo logs after restoring data files from the selected sparse backup. RMAN first restores data files from sparse backups and then recovers the data files.</p> <p>To perform recovery with the <code>FROM SPARSE</code> clause, the <code>COMPATIBLE</code> initialization parameter of the sparse database being restored must be 12.2 or higher.</p> <p><b>Note:</b> This clause can be used only when performing point-in-time recovery.</p>
<code>FROM NONSPARSE</code>	<p>Performs traditional complete recovery for the specified non-sparse database. Data files are first restored from non-sparse backups and then recovered. To perform point-in-time recovery with the <code>FROM NONSPARSE</code> clause, the <code>COMPATIBLE</code> initialization parameter of the sparse database being restored must be set to 12.2 or higher. Data files are restored from non-sparse backups first and then recovered.</p> <p><b>Note:</b> This clause can be used only when performing point-in-time recovery.</p>

Syntax Element	Description
FROM PLATFORM ' <i>platform</i> '	<p>Specifies the name of the source platform on which the cross-platform backup was created. The platform name specified must match the platform identifier stored in the cross-platform backup header.</p> <p>This clause is required when conversion is performed on the destination database. If conversion is performed on the source database (by using the TO PLATFORM clause in the BACKUP command), then this clause is optional. When this clause is omitted, you can still recover a cross-platform backup by specifying the FOREIGN DATAFILECOPY clause with the FROM BACKUPSET clause.</p> <p>To perform cross-platform tablespace transport by connecting over the network to a remote database, use the FROM PLATFORM clause with the FROM SERVICE clause. RMAN then creates the required backup sets on the source database, transfers them to the destination database, and then restores them on the destination.</p> <p>See <a href="#">FOREIGN DATAFILECOPY 'filename'</a>.</p> <p><b>See Also:</b> <i>Oracle Database Backup and Recovery User's Guide</i> for more information about source and destination platform conversion.</p>
FROM PREPLUGIN	<p>Uses preplugin incremental backups and preplugin archive redo log backups to recover a PDB. The PDB may be a source non-CDB or a PDB that was plugged in to the current CDB.</p>
FROM SERVICE <i>service_name</i>	<p>Recovers data files using backup sets that are transferred, over the network, from a remote database. <i>service_name</i> specifies the service name of the remote database.</p> <p>See "<a href="#">Restoring Data Files and Control Files Using Files from a Remote Host</a>".</p> <p>To perform cross-platform tablespace transport by connecting over the network to a remote database, use the FROM PLATFORM clause with the FROM SERVICE clause. RMAN connects to the source database, creates the required backups, transfers them to the destination, and then restores the backups on the destination.</p>
NONLOGGED BLOCK	<p>Extends the recovery to nonlogged blocks which are listed in the V\$NONLOGGED_BLOCK view. RMAN first performs a validation to determine the nonlogged block ranges and then uses these ranges to perform recovery of the objects specified in the <i>dbObject</i> clause. In Oracle Database 11.2 and earlier releases, information about nonlogged blocks was available in the V\$DATABASE_BLOCK_CORRUPTION view.</p> <p>When run on a physical standby database, RECOVER fetches data blocks from the primary database. When run on a primary database, data blocks are fetched from the most appropriate standby database. In this case, the primary database must be mounted.</p> <p>You must stop standby recovery before issuing a RECOVER command with this option.</p> <p>If the target database does not use Automatic Memory Management and the SGA_TARGET parameter is not set, then you must specify a value for the DATA_TRANSFER_CACHE_SIZE initialization parameter.</p> <p><b>See Also:</b> <i>Oracle Data Guard Concepts and Administration</i></p> <p><b>See Also:</b> <i>Oracle Database Administrator's Guide</i></p> <p><b>See Also:</b> <i>Oracle Database Reference</i></p>



Syntax Element	Description
FROM TAG 'tag_name'	<p>Specifies the tag for an incremental backup to be used during recovery. If the tagged backup does not contain all the necessary incrementals for recovery, then RMAN uses logs or incremental backups as needed from whatever is available. Tag names are not case sensitive and display in all uppercase.</p> <p><b>See Also:</b> <a href="#">BACKUP</a> to learn how a tag can be applied to an individual copy of a duplexed backup set, and to learn about the default file name format for backup tags</p>
NOPARALLEL	<p>Does not perform media recovery in parallel. Parallel execution is the default for RECOVER (see the description of the RECOVER . . . PARALLEL option).</p>
NOREDO	<p>Suppresses the application of redo logs during recovery. Only incremental backups are applied.</p> <p>One use of this option is to use incremental backups to update full backups of NOARCHIVELOG databases (see <a href="#">Example 3-6</a>). The NOREDO options is required if redo logs are not available. If you do not specify NOREDO when recovering a NOARCHIVELOG database, then RMAN ends recovery and issues an error.</p> <p><b>Note:</b> Incremental backups of NOARCHIVELOG databases can only be taken after a consistent shutdown.</p> <p>Another use is to update standby or duplicate databases. Incremental backups created with the BACKUP INCREMENTAL FROM SCN command can be applied at a standby or duplicate database. The standby database procedure is described in <i>Oracle Data Guard Concepts and Administration</i>.</p>
NOTABLEIMPORT	<p>Specifies that RMAN must not import recovered tables or table partitions into the target database.</p> <p>The recovered objects are stored in an Data Pump export dump file that is specified using DUMP FILE and DATAPUMP DESTINATION. If these clauses are omitted, the export dump file is created in a default location.</p> <p>When required, you need to explicitly import the tables or table partitions contained in the export dump file into the target database. Use the Data Pump import utility to import the recovered objects.</p> <p><b>Note:</b> You cannot use NOTABLEIMPORT with the REMAP TABLE or REMAP TABLESPACE clauses.</p>

Syntax Element	Description
PARALLEL	<p>Specifies parallel recovery (default).</p> <p>By default, the database uses parallel media recovery to improve performance of the roll forward phase of media recovery. To override the default behavior of performing parallel recovery, use the <code>RECOVER</code> with the <code>NOPARALLEL</code> option, or <code>RECOVER PARALLEL 0</code>.</p> <p>In parallel media recovery, the database uses a "division of labor" approach to allocate different processes to different data blocks while rolling forward, thereby making the operation more efficient. The number of processes is derived from the <code>CPU_COUNT</code> initialization parameter, which by default equals the number of CPUs on the system. For example, if parallel recovery is performed on a system where <code>CPU_COUNT</code> is 4, and only one data file is recovered, then four spawned processes read blocks from the data file and apply redo.</p> <p>Typically, recovery is I/O-bound on reads from and writes to data blocks. Parallelism at the block level may only help recovery performance if it increases total I/Os, for example, by bypassing operating system restrictions on asynchronous I/Os. Systems with efficient asynchronous I/O see little benefit from parallel media recovery.</p> <p><b>Note:</b> The <code>RECOVERY_PARALLELISM</code> initialization parameter controls instance or crash recovery only. Media recovery is not affected by the value used for <code>RECOVERY_PARALLELISM</code>.</p> <p><b>See Also:</b> The description of the <code>PARALLEL</code> clause in the discussion of <code>CREATE TABLE</code> in <i>Oracle Database SQL Language Reference</i></p>
<i>integer</i>	<p>Specifies the <i>integer</i> degree of parallelism.</p> <p>Each parallel thread may use one or two parallel execution servers. Optional.</p>
FILE_NAME_CONVERT	<p>Specifies how database file names on the source CDB map to the corresponding files on the destination CDB during cross-platform transport of a PDB to a destination CDB.</p> <p>Specify the pairs of strings used to convert the file names. You can use as many pairs of source and destination replacement strings as required. For example, you can set the string pattern to a value such as:</p> <pre>FILE_NAME_CONVERT = ('str1','str2','str3', 'str4' ...)</pre>
REMAP TABLE	<p>Renames recovered tables or table partitions in the target database.</p> <p>The recovered tables or table partitions can be mapped to a target database schema that is different from the one in which they originally existed. While recovering tables or table partitions into a different schema, you can either rename the objects or retain the original object names. You can import all the specified objects into the same target schema or into different target schemas.</p> <p>A single <code>RECOVER</code> command can contain tables and table partitions belonging to different source schemas.</p> <p>When you recover a partitioned table, if you remap only some partitions in the table, then all the table partitions are imported as separate tables. Named constraints and indexes are not imported when you use the <code>REMAP TABLE</code> option.</p> <p><b>Note:</b> You cannot remap a table or partition that is not listed in the <code>TABLE</code> clause of the <code>RECOVER</code> command.</p>

Syntax Element	Description
REMAP TABLESPACE <i>source_tablespace_name</i> : <i>target_tablespace_name</i>	Imports the recovered tables or table partitions into a tablespace that is different from the one to which they belonged in the source database. <i>source_tablespace_name</i> refers to the name of the tablespace in which the tables or partitions resided in the source database and <i>target_tablespace_name</i> refers to the name of the tablespace into which the tables or table partitions must be imported. Named constraints and indexes are not imported when you use the REMAP option.
SECTION SIZE <i>sizeSpec</i>	Parallelizes the validation by dividing each file into the specified section size. See " <a href="#">SECTION SIZE sizeSpec</a> ".
SKIP OFFLINE	Skips offline data files during recovery.
SKIP READONLY	Omits read-only files from the recovery.
TEST	Initiates a trial recovery. A trial recovery is useful if a normal recovery procedure has encountered a problem. It enables the database to look ahead into the redo stream to detect possible problems. The trial recovery applies redo in a way similar to normal recovery, but it does not write changes to disk and it rolls back its changes at the end of the trial recovery. <b>Note:</b> You can use this clause only if you have restored a backup taken since the last RESETLOGS operation. Otherwise, the database returns an error.
UNDO TABLESPACE <i>tablespace_name</i>	Specifies a list of tablespaces with undo segments at the target time. Only for use with RECOVER TABLESPACE. During TSPITR, RMAN needs information about which tablespaces had undo segments at the TSPITR target time. This information is usually available in the recovery catalog, if one is used. If there is no recovery catalog, or if the information is not found in the recovery catalog, then RMAN proceeds if the set of tablespaces with undo segments at the target time equals the set of tablespaces with undo segments now. If this assumption is not correct, then TSPITR fails with an error. In such a case, you can use UNDO TABLESPACE.
USING [COMPRESSED] BACKUPSET	Specifies that the files being recovered must be transferred from the remote database as compressed backup sets, if USING COMPRESSED BACKUPSET is used. By default, RMAN transfers files as backup sets. Therefore, even if you do not use the USING BACKUPSET clause, the files are transferred as backup sets. The compression algorithm from the RMAN configuration is used to perform compression. You can use a different compression algorithm by running the SET COMPRESSION ALGORITHM before your RECOVER command.
USING ' <i>filename</i> '	Performs cross-platform transport of a PDB into a different destination CDB. The XML file that contains the metadata required to plug the PDB into the destination CDB is specified using <i>filename</i> .
VALIDATE HEADER	Reports and validates—but does not restore—the backups that RMAN could use to restore files needed for the recovery. When you run RECOVER with VALIDATE HEADER, RMAN performs the same functions as when you specify the RESTORE . . . PREVIEW option. However, in addition to listing the files needed for restore and recovery, RMAN validates the backup file headers to determine whether the files on disk or in the media management catalog correspond to the metadata in the RMAN repository. <b>See Also:</b> The description of the RESTORE . . . PREVIEW option

**remapTableList**

This subclause specifies the tables or table partitions that must be recovered.

Syntax Element	Description
old_schema	Name of the schema that contains the tables or table partitions that are being recovered.
old_tablename	Name of the table that must be recovered.
partition	Name of the table partition that must be recovered.
new_schema	Name of the schema into which the tables and table partitions must be recovered.
new_tablename	Name of the recovered table or table partitions in the target database.

**Examples****Example 3-1 Recovering a Tablespace in an Open Database**

Assume that the disk containing the data files for tablespace `users` becomes unavailable because of a hardware error, but is repaired after a few minutes. This example takes tablespace `users` offline, uses automatic channels to restore the data files to their default location and recover them (deleting the logs that it restored from tape), then brings the tablespace back online.

```
ALTER TABLESPACE users OFFLINE IMMEDIATE;
RESTORE TABLESPACE users;
RECOVER TABLESPACE users DELETE ARCHIVELOG MAXSIZE 2M;
ALTER TABLESPACE users ONLINE;
```

**Example 3-2 Recovering Data Files Restored to New Locations**

This example uses the preconfigured disk channel and manually allocates one media management channel to use data file copies on disk and backups on tape, and restores a data file in tablespace `USERS` to a different location.

```
RUN
{
  ALLOCATE CHANNEL ch1 DEVICE TYPE sbt;
  ALTER TABLESPACE users OFFLINE IMMEDIATE;
  SET NEWNAME FOR DATAFILE '/disk1/oradata/prod/users01.dbf'
    TO '/disk2/users01.dbf';
  RESTORE TABLESPACE users;
  SWITCH DATAFILE ALL;
  RECOVER TABLESPACE users;
  ALTER TABLESPACE users ONLINE;
}
```

**Example 3-3 Performing DBPITR with a Backup Control File and Recovery Catalog**

Assume that all data files, all control files, and archived redo log 58 were lost due to a disk failure. Also assume that you do not have incremental backups. You must recover the database with available archived redo log files. You do not need to restore tablespace `TOOLS` because it has been read-only since before the most recent backup. After connecting RMAN to the target database and recovery catalog, issue the following commands:

```
STARTUP FORCE NOMOUNT;
RUN
```

```

{
  SET UNTIL SEQUENCE 40 THREAD 1; # Recover database until log sequence 40
  RESTORE CONTROLFILE;
  ALTER DATABASE MOUNT;
  RESTORE DATABASE SKIP TABLESPACE tools;
  RECOVER DATABASE SKIP TABLESPACE tools;
}
ALTER DATABASE OPEN RESETLOGS;

```

RMAN automatically skips the restore and recovery of data file 8, which is the data file in the read-only tablespace. The following portion of sample output indicates the skip:

```

using channel ORA_DISK_1
allocated channel: ORA_SBT_TAPE_1
channel ORA_SBT_TAPE_1: SID=104 device type=SBT_TAPE
channel ORA_SBT_TAPE_1: Oracle Secure Backup

skipping datafile 8; already restored to file /disk1/oradata/prod/tools01.dbf
channel ORA_DISK_1: starting datafile backup set restore
.
.
.
Finished restore at 19-FEB-13

Starting recover at 19-FEB-13
using channel ORA_DISK_1
using channel ORA_SBT_TAPE_1
datafile 8 not processed because file is read-only

```

### Example 3-4 Incrementally Updating Backups

By incrementally updating backups, you can avoid the overhead of making full image copy backups of data files, while also minimizing time required for media recovery of your database. This example enables you to recover to any SCN within the previous week, but enables you to avoid having to apply more than one day of redo.

Assume you run the following script daily. On first execution, the script creates an image copy backup of the database on disk with the specified tag. On the second through the seventh executions, the script creates a level 1 differential backup of the database. On the eighth and all subsequent executions, RMAN applies the level 1 incremental to the data file copy made 7 days ago and then makes a new level 1 backup with the changes from the previous day.

```

RUN
{
  RECOVER COPY OF DATABASE
    WITH TAG 'incr_update'
    UNTIL TIME 'SYSDATE - 7';
  BACKUP
    INCREMENTAL LEVEL 1
    FOR RECOVER OF COPY WITH TAG 'incr_update'
    DATABASE;
}

```

### Example 3-5 Recovery from Loss of a Control File on a Standby Database

Assume that the standby database `dgprod3` control files are lost because of a media failure. The primary and standby database share SBT storage. A backup of the primary database control file exists on tape.

You start the RMAN client and connect to `dgprod3` as `TARGET` and connect to the recovery catalog. The following RMAN commands restore a control file that is usable by the standby database, update the file names to existing files on disk, and recover the standby database:

```
RESTORE CONTROLFILE;
ALTER DATABASE MOUNT;
RECOVER DATABASE;
```

You can then start redo apply on the standby database.

### Example 3-6 Recovering a NOARCHIVELOG Database

You can perform limited recovery of changes to a database running in `NOARCHIVELOG` mode by applying incremental backups. The incremental backups must be consistent, like all backups of a database run in `NOARCHIVELOG` mode, so you cannot back up the database when it is open.

Assume that you run database `prod` in `NOARCHIVELOG` mode with a recovery catalog. You shut down the database consistently and make a level 0 backup of database `prod` to tape on Sunday afternoon. You shut down the database consistently and make a level 1 differential incremental backup to tape at 3:00 a.m. on Wednesday and Friday.

On Saturday, a media failure destroys half of the data files and all the online redo logs. Because the online logs are lost, you must specify the `NOREDO` option in the `RECOVER` command. Otherwise, RMAN searches for the redo logs after applying the Friday incremental backup and issues an error message when it does not find them.

After connecting RMAN to `prod` and the catalog database, recover as follows:

```
STARTUP FORCE NOMOUNT;
RESTORE CONTROLFILE;      # restore control file from consistent backup
ALTER DATABASE MOUNT;
RESTORE DATABASE;        # restore data files from consistent backup
RECOVER DATABASE NOREDO; # specify NOREDO because online redo logs are lost
ALTER DATABASE OPEN RESETLOGS;
```

The recovered database reflects only changes up through the time of the Friday incremental backup. Because there are no archived redo log files, there is no way to recover changes made after the incremental backup.

### Example 3-7 Recovering All Block Corruption in the Database

This example runs a backup validation to populate the `V$DATABASE_BLOCK_CORRUPTION` view, then recovers any corrupt blocks recorded in the view. Sample output is included for both commands.

```
RMAN> VALIDATE DATABASE;
```

```
Starting validate at 19-FEB-13
using channel ORA_DISK_1
channel ORA_DISK_1: starting validation of datafile
channel ORA_DISK_1: specifying datafile(s) for validation
.
.
.
List of Datafiles
=====
File Status Marked Corrupt Empty Blocks Blocks Examined High SCN
-----
1    FAILED 0                4070          57600          555975
```

```

File Name: /disk1/oradata/prod/system01.dbf
Block Type Blocks Failing Blocks Processed
-----
Data      1          41550
Index     0          7677
Other     0          4303
.
.
.
RMAN> RECOVER CORRUPTION LIST;

Starting recover at 19-FEB-13
using channel ORA_DISK_1
allocated channel: ORA_SBT_TAPE_1
channel ORA_SBT_TAPE_1: SID=104 device type=SBT_TAPE
channel ORA_SBT_TAPE_1: Oracle Secure Backup
searching flashback logs for block images until SCN 547548
finished flashback log search, restored 1 blocks

starting media recovery
media recovery complete, elapsed time: 00:00:03

Finished recover at 19-FEB-13

```

### Example 3-8 Recovering Tables Partitions from a Backup

This example recovers the partitions `sales_2009` and `sales_2010` from the table `SALES` to the time when the SCN of the target database was 34582. In the source database, the tables are owned by the schema `SH`. While importing these partitions into the target database, the partitions are created as tables named `historic_sales_2009` and `historic_sales_2010`.

```

RECOVER TABLE SH.SALES:SALES_2009, SH.SALES:SALES_2010
UNTIL SCN 34582
AUXILIARY DESTINATION '/tmp/oracle/recover'
REMAP TABLE 'SH'. 'SALES': 'SALES_2009': 'HISTORIC_SALES_2009',
'SH'. 'SALES': 'SALES_2010': 'HISTORIC_SALES_2010';

```

### Example 3-9 Recovering Tables to a Specified Log Sequence and Renaming the Tables

This example uses an auxiliary instance to recover the table `EMP` from the `SCOTT` schema to the time when the log sequence number of the database was 5466. After the `EMP` table is recovered, it is imported into the target database using the name `MY_EMP`.

```

RECOVER TABLE SCOTT.EMP
UNTIL SEQUENCE 5466
AUXILIARY DESTINATION '/tmp/recover'
REMAP TABLE 'SCOTT'. 'EMP': 'MY_EMP';

```

### Example 3-10 Recovering Tables to a Specified Time and Into a Different Tablespace

This example recovers tables `EMP` and `DEPT` to the point in time specified by the `UNTIL TIME` clause. The tables were originally part of the `EXAMPLE_TBS` tablespace. However, after the recovery operation, they are mapped to the tablespace `MY_TBS` in the target database.

```
RECOVER TABLE SCOTT.EMP, SCOTT.DEPT
  UNTIL TIME "TO_CHAR('12/23/2012 12:00:00','mm/dd/yyyy hh24:mi:ss')"
  AUXILIARY DESTINATION '/tmp/oracle/recover'
  REMAP TABLESPACE 'EXAMPLE_TBS':'MY_TBS';
```

### Example 3-11 Recovering Multiple Tables Into a Different Schema

This example recovers the tables `HR.EMPLOYEES` and `SH.CHANNELS` tables until the specified SCN. The recovered `EMPLOYEES` table is mapped to the `EXAMPLES` schema and the recovered `CHANNELS` table is mapped to the `TEST` schema. These schemas are already created in the target database. The `CHANNELS` table was stored in the `SALES_TBS` tablespace. After the table is recovered, it is mapped to the `NEW_SALES_TBS` tablespace. An auxiliary destination is used to store the temporary database files created as part of the table recovery process.

To recover this table, you must have a backup of the `SYSTEM`, `SYSAUX`, `undo`, `HR`, and `SH` tablespaces. The database must be in `ARCHIVELOG` mode when the backup was created.

```
RECOVER TABLE hr.employees, sh.channels
  UNTIL SCN 3456
  REMAP TABLE hr.employees:examples.employees, sh.channels:test.channels
  REMAP TABLESPACE 'SALES_TBS':'NEW_SALES_TBS'
  AUXILIARY DESTINATION '/tmp/auxdest';
```

### Example 3-12 Recovering Table Partitions into a Different Schema

This example recovers the partitions `SALES_H1_1997` and `SALES_H2_1997` in the `SH` schema to a previous point in time that is specified using an SCN. The partitions are renamed as `historic_sales_h1_1997` and `historic_sales_h2_1997` respectively. The recovered partitions must be imported into the schema `new_sh`, which exists in the target database.

`COMPATIBLE` must be set to 11.1.0 or higher because partitions are being recovered. A backup of the `SYSTEM`, `SYSAUX`, `UNDO`, and `SH` tablespaces at the specified recovery SCN exists. The database must be in `ARCHIVELOG` mode when the backup was created.

```
RECOVER TABLE sh.sales:sales_h1_1997, sh.sales:sales_h2_1997
  UNTIL SCN 810234878
  REMAP TABLE sh.sales:sales_h1_1997:sh.historic_sales_h1_1997,
  sh.sales:sales_h2_1997:sh.historic_sales_h2_1997
  AUXILIARY DESTINATION '/tmp/auxdest/';
```

### Example 3-13 Recovering a Cross-platform Backup of a PDB Into a Destination CDB

This example restores a cross-platform consistent incremental level 1 backup of the PDB `pdb2` on a destination database. The destination CDB and the source CDB are on different platforms, but use the same endian format.

The `USING` clause specifies the name of the XML file that contains metadata required to plug the PDB into a destination CDB. The `FOREIGN DATAFILECOPY` clause lists all the data files that were created when this PDB's data files were restored. Recovery needs to be performed for all these data files. The `FILE_NAME_CONVERT` clause specifies how file names on the source CDB must be renamed in the destination CDB

```
RECOVER
  FROM PLATFORM 'Linux x86 64-bit'
  USING '/u02/backup_restore/metadata_pdb2.xml'
  FILE_NAME_CONVERT = ('/u01/oradata', '/u02/oradata/cdb')
```



```
FOREIGN DATAFILECOPY '/u02/oradata/pdb1.dbf', '/u02/oradata/  
pdb1_tmp.dbf'  
FROM BACKUPSET '/u02/backup_restore/bkup_level1_pdb1.bck';
```

## 3.2 REGISTER DATABASE

### Purpose

Use the `REGISTER DATABASE` command to register the target database in the recovery catalog so that RMAN can maintain its metadata. RMAN obtains all information it needs to register the target database from the target database itself.



### See Also:

*Oracle Database Backup and Recovery User's Guide* and [CREATE CATALOG](#)

### Prerequisites

Execute this command only at the RMAN prompt. RMAN must be connected to a recovery catalog and a mounted or open target database. The database that you are registering must not be currently registered in the recovery catalog.

You can only register a target database with a DBID that is unique within the recovery catalog. Databases with the same name are permitted if the DBID values are different. The database that you are registering must not be a standby database.

### Usage Notes

RMAN automatically registers a new standby database in the recovery catalog when the primary database for the standby database is registered in the recovery catalog and either of the following conditions is true:

- RMAN is connected to a database instance that has a `DB_UNIQUE_NAME` unknown to the recovery catalog.
- You execute the `CONFIGURE DB_UNIQUE_NAME` command for a database that is not known to the recovery catalog.

The `REGISTER DATABASE` command fails when RMAN detects duplicate DBIDs. This situation can arise when databases are created by copying files from an existing database rather than by using the `DUPLICATE` command. If this failure occurs, then you can change the DBID of the copied database with the `DBNEWID` utility and then retry the `REGISTER DATABASE` command.

If you open a database with the `RESETLOGS` option and later register this database in the recovery catalog, then the recovery catalog records the `DB_NAME` for the old incarnations as `UNKNOWN` because the old incarnations were not previously registered. Do not try to remove these records.

 **Note:**

If you are using RMAN with different target databases that have the same database name and DBID, then be careful to always specify the correct recovery catalog schema when invoking RMAN.

 **See Also:**

*Oracle Database Utilities* to learn how to use the DBNEWID utility

**Syntax****register::=**

```
→ REGISTER DATABASE > ; →
```

**Example****Example 3-14 Registering a Database**

This example registers a new target database in the recovery catalog. Sample output is included.

```
RMAN> CONNECT TARGET /  
  
connected to target database: PROD (DBID=1619241818)  
  
RMAN> CONNECT CATALOG rco@catdb  
  
recovery catalog database Password: password  
connected to recovery catalog database  
  
RMAN> REGISTER DATABASE;  
  
database registered in recovery catalog  
starting full resync of recovery catalog  
full resync complete
```

## 3.3 RELEASE CHANNEL

**Purpose**

Use the `RELEASE CHANNEL` command to release a normal or maintenance channel while maintaining a connection to a target database instance. A normal channel is allocated with `ALLOCATE CHANNEL`, whereas a maintenance channel is allocated with `ALLOCATE CHANNEL FOR MAINTENANCE`.

## Prerequisites

To release a normal channel, use the syntax shown in the `release::=` diagram. Execute this form of `RELEASE CHANNEL` only within a `RUN` command and specify the channel name with the same identifier used in the `ALLOCATE CHANNEL` command.

To release a maintenance channel, use the syntax shown in the `releaseForMaint::=` diagram. Execute this form of `RELEASE CHANNEL` only at the RMAN prompt, not within a `RUN` command.

## Usage Notes

Maintenance channels are unaffected by `ALLOCATE CHANNEL` and `RELEASE CHANNEL` commands issued within a `RUN` command.

Using `RELEASE CHANNEL` to release channels within `RUN` is optional, because RMAN automatically releases all normal channels when a `RUN` command terminates.

## Syntax

### `release::=`

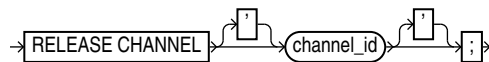

### `releaseForMaint::=`

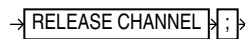

## Semantics

Syntax Element	Description
<code>channel_id</code>	Specifies the case-sensitive channel ID used in the <code>ALLOCATE CHANNEL</code> command (see <a href="#">Example 3-15</a> ).

## Examples

### Example 3-15 Releasing a Channel Allocated in a RUN Command

This example allocates an SBT channel named `ch1` with parameters for a set of tapes intended for daily backups, backs up the database, and then releases this channel. The example then allocates an SBT channel named `ch1` with parameters for a set of tapes intended for weekly backups, and makes another database backup:

```

RUN
{
  ALLOCATE CHANNEL ch1 DEVICE TYPE sbt
    PARMS='ENV=(OB_MEDIA_FAMILY=daily_bkp)';
  BACKUP DATABASE;
  RELEASE CHANNEL ch1;
  ALLOCATE CHANNEL ch1 DEVICE TYPE sbt
    PARMS='ENV=(OB_MEDIA_FAMILY=weekly_bkp)';
}
  
```

```

    BACKUP DATABASE;
}

```

A `RELEASE CHANNEL` command at the end of the `RUN` command is optional because RMAN automatically releases channel `ch1`.

### Example 3-16 Releasing a Maintenance Channel

This example shows the transcript of an RMAN session. The example allocates an SBT maintenance channel and then crosschecks and deletes backups on tape. After the SBT channel is released, RMAN uses the default disk channel to back up the database.

```

RMAN> ALLOCATE CHANNEL FOR MAINTENANCE DEVICE TYPE sbt;

```

```

allocated channel: ORA_MAINT_SBT_TAPE_1
channel ORA_MAINT_SBT_TAPE_1: SID=105 device type=SBT_TAPE
channel ORA_MAINT_SBT_TAPE_1: Oracle Secure Backup

```

```

RMAN> CROSSCHECK BACKUP;

```

```

crosschecked backup piece: found to be 'AVAILABLE'
backup piece handle=1jiah8ln_1_1 RECID=25 STAMP=615031479
crosschecked backup piece: found to be 'AVAILABLE'
backup piece handle=1kiah8pk_1_1 RECID=26 STAMP=615031612
crosschecked backup piece: found to be 'AVAILABLE'
backup piece handle=1niah973_1_1 RECID=28 STAMP=615032036
Crosschecked 3 objects

```

```

RMAN> DELETE BACKUP;

```

List of Backup Pieces

BP Key	BS Key	Pc#	Cp#	Status	Device Type	Piece Name
1333	1331	1	1	AVAILABLE	SBT_TAPE	1jiah8ln_1_1
1334	1332	1	1	AVAILABLE	SBT_TAPE	1kiah8pk_1_1
1427	1423	1	1	AVAILABLE	SBT_TAPE	1niah973_1_1

```

Do you really want to delete the above objects (enter YES or NO)? YES
deleted backup piece
backup piece handle=1jiah8ln_1_1 RECID=25 STAMP=615031479
deleted backup piece
backup piece handle=1kiah8pk_1_1 RECID=26 STAMP=615031612
deleted backup piece
backup piece handle=1niah973_1_1 RECID=28 STAMP=615032036
Deleted 3 objects

```

```

RMAN> RELEASE CHANNEL;

```

```

released channel: ORA_MAINT_SBT_TAPE_1

```

```

RMAN> BACKUP DATABASE;

```

```

Starting backup at 20-FEB-13
allocated channel: ORA_DISK_1
channel ORA_DISK_1: SID=105 device type=DISK
channel ORA_DISK_1: starting full datafile backup set
channel ORA_DISK_1: specifying datafile(s) in backup set

```

## 3.4 REPAIR FAILURE

### Purpose

Use the `REPAIR FAILURE` command to repair database failures identified by the Data Recovery Advisor.

The recommended workflow is to run `LIST FAILURE` to display failures, `ADVISE FAILURE` to display repair options, and `REPAIR FAILURE` to fix the failures.

### Note:

Starting in Oracle Database 19c, the Data Recovery Advisor (DRA) feature is deprecated.

The deprecation of DRA includes deprecation of the following Oracle Recovery Manager (RMAN) commands: `LIST FAILURE`, `ADVISE FAILURE`, `REPAIR FAILURE`, and `CHANGE FAILURE`. Database administrators will no longer have access to these commands. There is no replacement feature for DRA.

### Prerequisites

The target database instance must be started. The database must be a single-instance database and must not be a physical standby database.

Ensure that only one RMAN session is running the `REPAIR FAILURE` command. The only exception is `REPAIR FAILURE ... PREVIEW`, which is permitted in concurrent RMAN sessions.

To perform an automated repair, the Data Recovery Advisor may require specific backups and archived redo log files. If the files needed for recovery are not available, then recovery is not possible.

### Usage Notes

Repairs are consolidated whenever possible so that a single repair can fix multiple failures. Be advised that `REPAIR FAILURE` requires you to explicitly run `ADVISE FAILURE` in the current session to successfully repair each of the identified failures. You typically iterate through a `REPAIR` session with the following commands:

- `REPAIR FAILURE;`
- `LIST FAILURE;`
- `ADVISE FAILURE;`
- `REPAIR FAILURE;`

RMAN always verifies that failures are still relevant and automatically closes fixed failures. RMAN does not attempt to repair a failure that is fixed, nor does it repair a failure that is obsolete because new failures were introduced after `ADVISE FAILURE` ran.

By default, `REPAIR FAILURE` prompts for confirmation before it begins executing. After executing a repair, RMAN reevaluates all existing failures on the chance that they may also have been fixed.

 **See Also:**

[Example 3-17](#) for a complete example on using the Data Recovery Advisor to diagnose and repair failures

**Oracle RAC and Data Recovery Advisor**

If a data failure brings down all instances of an Oracle RAC database, then you can mount the database in single-instance mode and use Data Recovery Advisor to detect and repair control file, `SYSTEM` data file, and dictionary failures. You can also initiate health checks to test other database components for data failures. This approach does not detect data failures that are local to other cluster instances, for example, an inaccessible data file.

**Syntax**

***repair***::=

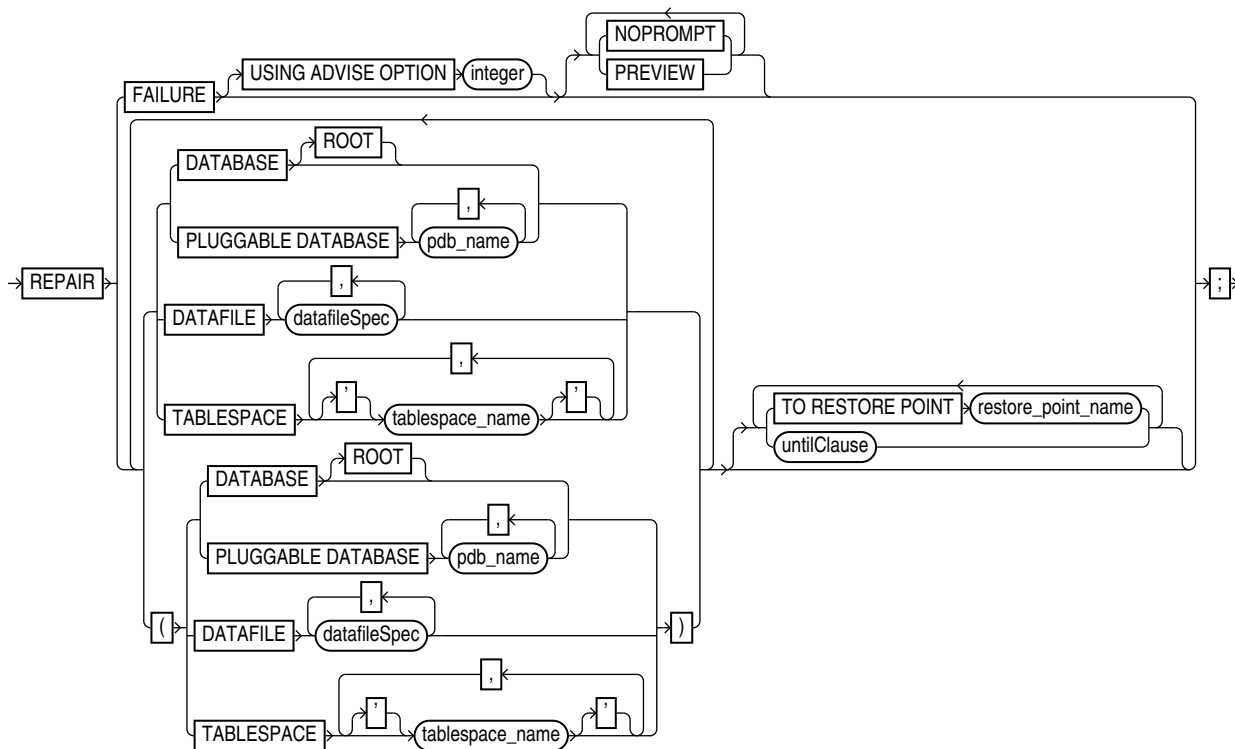

**Semantics**

***repair***

Syntax Element	Description
REPAIR FAILURE	Repairs failures recorded in the Automated Diagnostic Repository. If you execute <code>REPAIR FAILURE</code> with no other command options, then RMAN uses the first repair option of the most recent <code>ADVISE FAILURE</code> command in the current session.
USING ADVISE OPTION <i>integer</i>	Specifies a repair option by its option number ( <i>not</i> its failure number). You can obtain repair option numbers from the <code>ADVISE FAILURE</code> command.
NOPROMPT	Suppresses the confirmation prompt. This is the default option if you run <code>REPAIR FAILURE</code> in a command file.
PREVIEW	Does not make any repairs and generates a script with all repair actions and comments. By default the script is displayed to standard output. You can use the <code>SPOOL</code> command to write the script to an editable file (see <a href="#">Example 3-18</a> ).
DATABASE	Repairs all data files of the selected database. To repair all data files of a CDB, run the <code>REPAIR DATABASE</code> command when connected to root. Where possible, <code>REPAIR</code> also automatically takes a file offline, restores and recovers it, and then brings it back online again.
PLUGGABLE DATABASE <i>pdb_name</i>	Repairs all data files in one or more PDBs specified in a comma-delimited list.
DATABASE ROOT	Repairs data files in the CDB root. Connect to the root as a common user with the <code>SYSDBA</code> or <code>SYSBACKUP</code> privilege.
DATAFILE <i>datafileSpec</i>	Specifies a list of one or more data files for repair. See <a href="#">datafileSpec</a> for more information on how you can list the data files.
TABLESPACE <i>tablespace_name</i>	Specifies the names of one or more tablespaces for repair. RMAN translates tablespace names internally into a list of data files while repairing the tablespace. In a CDB, it repairs the tablespaces in the root. In a PDB, it repairs the tablespaces in that selected PDB.
TO RESTORE POINT <i>restore_point_name</i>	Specifies a restore point as an upper, inclusive limit for data files that will be repaired.
<i>untilClause</i>	Sets the end time, SCN, or log sequence number for repair. See <a href="#">untilClause</a> for more information on how to use this clause.

## Examples

### Example 3-17 Repairing Failures

This example repairs all failures known to the Data Recovery Advisor. The example repairs two failures: missing data files and a data file with corrupt blocks. After the recovery, RMAN asks whether it should open the database (user-entered text is in bold).

```

RMAN> LIST FAILURE;

List of Database Failures
=====

Failure ID Priority Status   Time Detected Summary
-----
142          HIGH    OPEN    23-APR-13  One or more non-system datafiles are missing
101          HIGH    OPEN    23-APR-13  Datafile 1: '/disk1/oradata/prod/system01.dbf'
                                     contains one or more corrupt blocks

RMAN> ADVISE FAILURE;

List of Database Failures
=====

```

```
=====
Failure ID Priority Status Time Detected Summary
-----
142 HIGH OPEN 23-APR-13 One or more non-system datafiles
are missing
101 HIGH OPEN 23-APR-13 Datafile 1: '/disk1/oradata/prod/system01.dbf'
contains one or more corrupt blocks

analyzing automatic repair options; this may take some time
using channel ORA_DISK_1
analyzing automatic repair options complete

Mandatory Manual Actions
=====
no manual actions available

Optional Manual Actions
=====
1. If file /disk1/oradata/prod/users01.dbf was unintentionally renamed or moved, restore it

Automated Repair Options
=====
Option Repair Description
-----
1 Restore and recover datafile 28; Perform block media recovery of
block 56416 in file 1
Strategy: The repair includes complete media recovery with no data loss
Repair script: /disk1/oracle/log/diag/rdbms/prod/prod/hm/reco_660500184.hm

RMAN> REPAIR FAILURE;

Strategy: The repair includes complete media recovery with no data loss
Repair script: /disk1/oracle/log/diag/rdbms/prod/prod/hm/reco_475549922.hm
contents of repair script:
# restore and recover datafile
alter database datafile 28 offline;
restore datafile 28;
recover datafile 28;
alter database datafile 28 online;
# block media recovery
recover datafile 1 block 56416;

Do you really want to execute the above repair (enter YES or NO)? YES
executing repair script

sql statement: alter database datafile 28 offline

Starting restore at 23-APR-13
using channel ORA_DISK_1

channel ORA_DISK_1: starting datafile backup set restore
channel ORA_DISK_1: specifying datafile(s) to restore from backup set
channel ORA_DISK_1: restoring datafile 00028 to /disk1/oradata/prod/users01.dbf
channel ORA_DISK_1: reading from backup piece /disk2/PROD/backupset/2013_04_18/
o1_mf_nnndf_TAG20130418T182042_32fjzd3z_.bkp
channel ORA_DISK_1: piece handle=/disk2/PROD/backupset/2013_04_18/
o1_mf_nnndf_TAG20130418T182042_32fjzd3z_.bkp tag=TAG20130418T182042
channel ORA_DISK_1: restored backup piece 1
channel ORA_DISK_1: restore complete, elapsed time: 00:00:03
Finished restore at 23-APR-13

Starting recover at 23-APR-13
using channel ORA_DISK_1

starting media recovery
media recovery complete, elapsed time: 00:00:01

Finished recover at 23-APR-13
```



```
sql statement: alter database datafile 28 online

Starting recover at 23-APR-13
using channel ORA_DISK_1
searching flashback logs for block images until SCN 429690
finished flashback log search, restored 1 blocks

starting media recovery
media recovery complete, elapsed time: 00:00:03

Finished recover at 23-APR-13
repair failure complete
```

### Example 3-18 Previewing a Repair

The following example previews a repair of the first repair option of the most recent [ADVISE FAILURE](#) command in the current session. The sample output for the `LIST FAILURE` and `ADVISE FAILURE` commands is not shown in the example.

```
RMAN> LIST FAILURE;
.
.
.
RMAN> ADVISE FAILURE;
.
.
.
RMAN> REPAIR FAILURE PREVIEW;

Strategy: The repair includes complete media recovery with no data loss
Repair script: /disk1/oracle/log/diag/rdbms/prod/prod/hm/reco_3200987003.hm

contents of repair script:
# block media recovery
recover datafile 1 block 56416;
```

You can use [SPOOL](#) with `REPAIR FAILURE ... PREVIEW` to write a repair script to a file. You can then edit this script and execute it manually. The following example spools a log a repair preview to `/tmp/repaircmd.dat`.

```
RMAN> SPOOL LOG TO '/tmp/repaircmd.dat';
RMAN> REPAIR FAILURE PREVIEW;
RMAN> SPOOL LOG OFF;
```

## 3.5 REPLACE SCRIPT

### Purpose

Use the `REPLACE SCRIPT` command to replace an existing script stored in the recovery catalog. If the script does not exist, then `REPLACE SCRIPT` creates it.



#### See Also:

[CREATE SCRIPT](#) to learn how to create stored scripts

## Prerequisites

Execute `REPLACE SCRIPT` only at the RMAN prompt. RMAN must be connected to a target database and a recovery catalog. The recovery catalog database must be open.

If you are replacing a local script, then you must be connected to the target database that you connected to when you created the script.

## Substitution Variables in Stored Scripts

RMAN supports the use of substitution variables in a stored script. `&1` indicates where to place the first value, `&2` indicate where to place the second value, and so on. Special characters must be quoted.

The substitution variable syntax is `&integer` followed by an optional period, for example, `&1.3`. The optional period is part of the variable and replaced with the value, thus enabling the substitution text to be immediately followed by another integer. For example, if you pass the value `mybackup` to a command file that contains the substitution variable `&1.3`, then the result of the substitution is `mybackup3`. To create the result `mybackup.3`, you use two periods in `&1..3`.

When you create a stored script with substitution variables, you must provide example values at create time. You can provide these values with the `USING` clause when starting RMAN (see [RMAN](#)) or enter them when prompted (see [Example 2-75](#)).

## Syntax

**`replaceScript::=`**

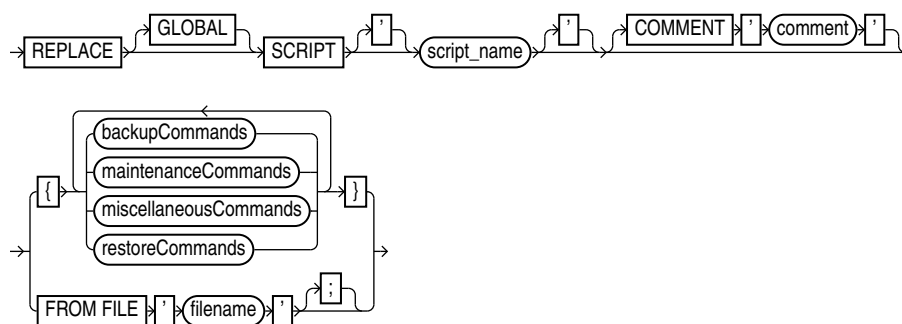

([backupCommands::=](#), [maintenanceCommands::=](#), [miscellaneousCommands::=](#), [restoreCommands::=](#))

## Semantics

Syntax Element	Description
GLOBAL	Identifies the script as global. <b>Note:</b> A virtual private catalog has read-only access to global scripts. Creating or updating global scripts must be done while RMAN is connected to the base recovery catalog. <b>See Also:</b> " <a href="#">Usage Notes</a> " for an explanation of the difference between global and local scripts

Syntax Element	Description
<code>SCRIPT <i>script_name</i></code>	Identifies the local or global script being replaced.
<code>COMMENT '<i>comment</i>'</code>	Associates an explanatory comment with the stored script in the recovery catalog. The comment is shown in the output of <code>LIST SCRIPT NAMES</code> .
<code><i>backupCommands</i></code> <code><i>maintenanceCommands</i></code> <code><i>restoreCommands</i></code> <code><i>miscellaneousCommands</i></code>	Specifies commands to include in the stored script. The commands allowable within the brackets of the <code>REPLACE SCRIPT '<i>script_name</i>' {...}</code> command are the same commands supported within a <code>RUN</code> block. Any command that is valid within a <code>RUN</code> command is permitted in the stored script. The following commands are not permitted within stored scripts: <code>RUN</code> , <code>@</code> (at sign), and <code>@@</code> (double at sign).
<code>FROM FILE '<i>filename</i>'</code>	Reads the sequence of commands to define the script from the specified file. The file resembles the body of a valid stored script. The first line of the file must be a left brace ( { ) and the last line must contain a right brace ( } ). The <code>RMAN</code> commands in the file must be valid in a stored script.

## Example

### Example 3-19 Replacing a Recovery Catalog Script

Assume that you start the RMAN client and connect to database `prod` as `TARGET` and then connect to a recovery catalog. You use `CREATE SCRIPT` to create a global script named `backup_db` as follows:

```
CREATE GLOBAL SCRIPT backup_db
COMMENT "back up any database from the recovery catalog, with logs"
{
    BACKUP DATABASE;
}
```

You then use `LIST SCRIPT NAMES` to list all scripts known to the recovery catalog:

```
RMAN> LIST SCRIPT NAMES;
```

List of Stored Scripts in Recovery Catalog

Global Scripts

```
Script Name
Description
-----
backup_db
back up any database from the recovery catalog, with logs
```

You then run the following `REPLACE SCRIPT` command with the intention of editing the `backup_db` global script:

```
RMAN> REPLACE SCRIPT backup_db { BACKUP DATABASE PLUS ARCHIVELOG; }

replaced script backup_db
```

Because you did not specify the `GLOBAL` keyword, RMAN creates a local script named `backup_db` in addition to the global script named `backup_db`. `LIST SCRIPT NAMES` shows both the global and local script recorded in the recovery catalog:

```

RMAN> LIST SCRIPT NAMES;

```

List of Stored Scripts in Recovery Catalog

Scripts of Target Database PROD

```

Script Name
Description
-----

```

```

backup_db

```

Global Scripts

```

Script Name
Description
-----

```

```

backup_db
back up any database from the recovery catalog, with logs

```

You can then delete the local script named `backup_db` with **DELETE SCRIPT** and replace the global script as follows:

```

RMAN> DELETE SCRIPT backup_db;

```

```

deleted script: backup_db

```

```

RMAN> REPLACE GLOBAL SCRIPT backup_db { BACKUP DATABASE PLUS ARCHIVELOG; }

```

```

replaced global script backup_db

```

The **LIST SCRIPT NAMES** command now shows that only one script named `backup_db` exists in the catalog:

```

RMAN> LIST SCRIPT NAMES;

```

List of Stored Scripts in Recovery Catalog

Global Scripts

```

Script Name
Description
-----

```

```

backup_db

```

The **PRINT SCRIPT** command confirms the changes to the global script:

```

RMAN> PRINT GLOBAL SCRIPT backup_db;

```

```

printing stored global script: backup_db
{ BACKUP DATABASE PLUS ARCHIVELOG; }

```

## 3.6 REPORT

### Purpose

Use the **REPORT** command to perform detailed analyses of the RMAN repository. RMAN writes the report to standard output or the message log file.

 **See Also:**

*Oracle Database Backup and Recovery User's Guide* to learn how to create RMAN reports

**Prerequisites**

Execute this command only at the RMAN prompt. Either of the following conditions must be met:

- RMAN must be connected to a target database.
- RMAN must be connected to a recovery catalog and **SET DBID** must have been run.

**Syntax**

**report::=**

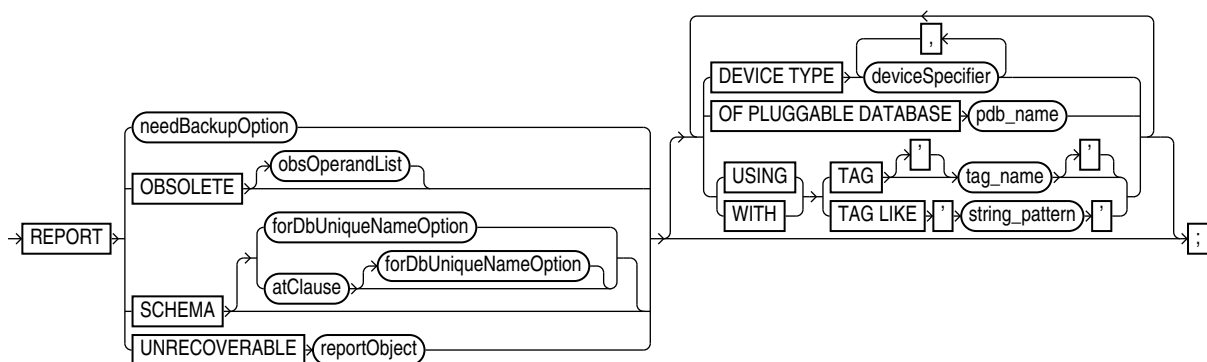

([needBackupOption::=](#), [atClause::=](#), [reportObject::=](#), [obsOperandList::=](#), [deviceSpecifier::=](#))

**needBackupOption::=**

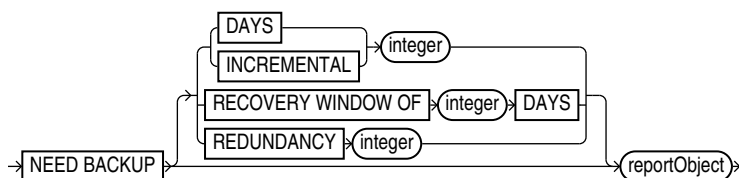

([reportObject::=](#))

**reportObject::=**

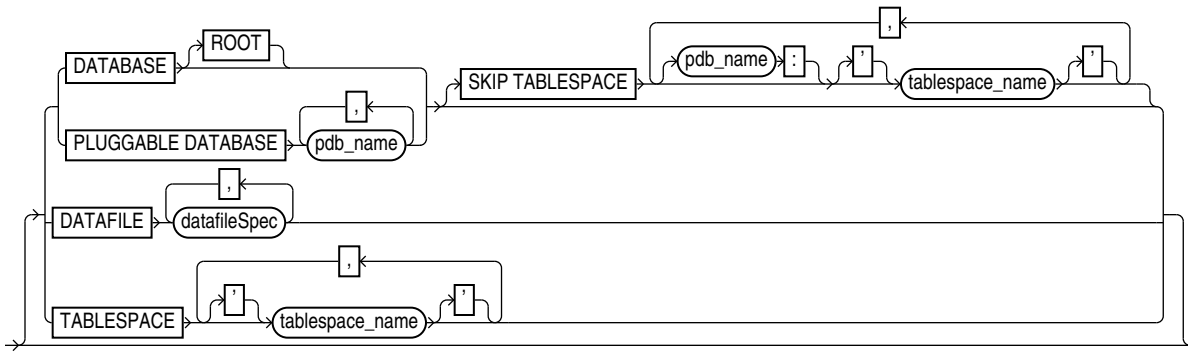

(datafileSpec::=)

**atClause::=**

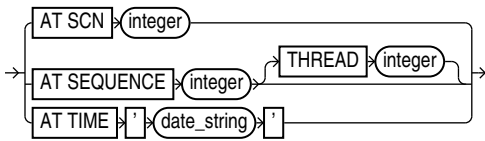

### Semantics

#### **report**

This clause specifies the type of report.

Syntax Element	Description
<a href="#">needBackupOption</a>	Lists files that require backups. <b>See Also:</b> <a href="#">needBackupOption</a>

Syntax Element	Description
OBSOLETE <a href="#">obsOperandList</a>	<p>Lists full backups, data file copies, and archived redo log files recorded in the RMAN repository that can be deleted because they are no longer needed. See <a href="#">Table 3-6</a> for description of output. The command works in two steps:</p> <ol style="list-style-type: none"> <li>1. For each data file that has been backed up, RMAN identifies the oldest full backup, level 0 backup, or image copy that is not obsolete under the retention policy. Any backup of the data file older than the one identified in this step is considered obsolete.</li> <li>2. Any archived redo log files and level 1 incremental backups that are older than the oldest nonobsolete full backup are considered obsolete. These files are obsolete because no full or level 0 backup exists to which they can be applied. Incremental level 1 backups or archived redo log files are not considered obsolete if they can be applied to nonobsolete level 0 or full backups.</li> </ol> <p>The subclause <a href="#">obsOperandList</a> describes the criteria that RMAN uses to determine what is obsolete. If you do not specify parameters in <a href="#">obsOperandList</a>, then RMAN uses the options specified in <a href="#">CONFIGURE RETENTION POLICY</a> (see <a href="#">Example 3-22</a>). If you use this option with <code>DEVICE TYPE</code>, then RMAN only considers backups and copies created on the specified device. If the retention policy is disabled, then RMAN does not consider any backups as obsolete. Thus, RMAN issues an error when you run <code>REPORT OBSOLETE</code> with no other options and the retention policy is <code>NONE</code>.</p> <p><b>Note:</b> A backup made with the <code>KEEP UNTIL TIME</code> clause is obsolete after the <code>KEEP</code> time passes, regardless of the configured retention policy settings.</p>
SCHEMA	<p>Lists the names of all data files (permanent and temporary) and tablespaces for the target database at the specified point in time. See <a href="#">Table 3-1</a> for description of output.</p> <p>For <code>REPORT SCHEMA</code> without <a href="#">forDbUniqueNameOption</a>, a target database connection is required, but a recovery catalog connection is optional.</p>
<a href="#">forDbUniqueNameOption</a>	<p>Reports the names of all data files and tablespaces for the database specified by its <code>DB_UNIQUE_NAME</code>.</p> <p>You can specify a database with <code>db_unique_name</code> or use <code>ALL</code> for all uniquely named databases recorded in the catalog for a particular <code>DBID</code>. A database is uniquely identified in the recovery catalog by a <code>DBID</code> and the value of the <code>DB_UNIQUE_NAME</code> initialization parameter.</p> <p>RMAN must be connected to a recovery catalog. RMAN must be connected to a target database or <code>SET DBID</code> must have been run.</p> <p><b>See Also:</b> <a href="#">forDbUniqueNameOption</a> for descriptions of the options in this clause</p>
<a href="#">atClause</a>	<p>Specifies an SCN, log sequence number, or time.</p>
UNRECOVERABLE <a href="#">reportObject</a>	<p>Lists all unrecoverable data files. See <a href="#">Table 3-7</a> for description of output.</p> <p>A data file is considered unrecoverable if an unrecoverable operation has been performed against an object residing in the data file since the last backup of the data file. In an unrecoverable operation, redo is not generated. Examples are direct load of table data and updates with the <code>NOLOGGING</code> option.</p> <p><b>Note:</b> The nonexistence of any backup of a data file is not sufficient reason to consider it unrecoverable. Such data files can be recovered with the <code>CREATE DATAFILE</code> command, if redo logs starting from when the file was created still exist.</p>
DEVICE TYPE <a href="#">deviceSpecifier</a>	<p>Specifies the type of storage device. RMAN only considers backups and copies available on the specified device for its report.</p>

Syntax Element	Description
OF PLUGGABLE DATABASE <i>pdb_name</i>	Reports the backups and copies for the PDB specified by <i>pdb_name</i> .
TAG <i>tag_name</i>	Reports the backups and copies with tag specified by <i>tag_name</i> .
TAG LIKE <i>string_pattern</i>	Reports the backups and copies whose tag matches the pattern specified by <i>string_pattern</i> .

### ***needBackupOption***

This clause reports only on files that need backups.

Syntax Element	Description
NEED BACKUP	Lists all data files in the specified <a href="#">reportObject</a> that require a new backup.  The report assumes that you restore the most recent backup. If you do not specify any option, then RMAN uses the current retention policy configuration. If the retention policy is disabled ( <code>CONFIGURE RETENTION POLICY TO NONE</code> ), then RMAN generates an error.
DAYS <i>integer</i>	Lists all data files requiring more than the specified number of days' worth of archived redo log files for complete recovery. For example, <code>REPORT NEED BACKUP DAYS 7 DATABASE</code> shows the data files whose recovery requires more than seven days' worth of archived redo log files. See <a href="#">Table 3-2</a> for description of output.  If the target database control file is mounted and current, then RMAN makes the following optimizations to this report: <ul style="list-style-type: none"> <li>Files that are offline and whose most recent backup contains all changes to the file are not included.</li> <li>Files that were offline and are now online, and whose most recent backup contains all changes up to the offline time, are only reported if they have been online for more than the specified number of days.</li> </ul>
INCREMENTAL <i>integer</i>	Specifies a threshold number of incremental backups required for recovery (see <a href="#">Example 3-21</a> ). If complete recovery of a data file requires more than <i>integer</i> incremental backups, then the data file requires a new full backup. See <a href="#">Table 3-3</a> for description of output.  <b>Note:</b> Files for which no backups exist do not appear in this list: issue the <code>REPORT NEED BACKUP REDUNDANCY</code> command to display them.
RECOVERY WINDOW OF <i>integer</i> DAYS	Reports data files for which there are not sufficient backups to satisfy a recovery window-based retention policy for the specified number of days, that is, data files without sufficient backups for point-in-time recovery to any point back to the time <code>SYSDATE - integer</code> . See <a href="#">Table 3-4</a> for description of output.
REDUNDANCY <i>integer</i>	Specifies the minimum number of backups or copies that must exist for a data file to be considered <i>not</i> in need of a backup. In other words, a data file needs a backup if there are fewer than <i>integer</i> backups or copies of this file. For example, <code>REDUNDANCY 2</code> means that if there are fewer than two copies or backups of a data file, then it needs a new backup. See <a href="#">Table 3-5</a> for description of output.
<a href="#">reportObject</a>	Specifies the object for which you are generating the report.

### ***reportObject***



This subclause specifies the data files to be included in the report. The report can include the entire database (optionally skipping certain tablespaces), a list of tablespaces, or a list of data files. RMAN includes objects from prior incarnations.

Syntax Element	Description
DATABASE	Lists backups or data file copies of all files in the database. <b>Note:</b> Specify <code>SKIP TABLESPACE <i>tablespace_name</i></code> to exclude the specified tablespace from the DATABASE specification.
DATABASE ROOT	Specifies the root in a CDB. Connect to the root.
PLUGGABLE DATABASE <i>pdb_name</i>	Lists backups or data file copies in one or more PDBs in a CDB. Use a comma-delimited list to specify multiple PDBs. Connect to the root to report on one or more PDBs using this syntax,.
DATAFILE <a href="#">datafileSpec</a>	Lists the specified data files. RMAN reports on backups or data file copies that contain at least one specified data file.
TABLESPACE <i>tablespace_name</i>	Lists data files in the specified tablespace. RMAN reports on backups or data file copies that include at least one data file from a specified tablespace. When connected to the root in a CDB, refers to tablespaces in the root. Refers to tablespaces in a PDB when connected directly to a PDB.

### **atClause**

This subclause specifies a point in time as a time, SCN, or log sequence number. You must be connected to a recovery catalog when issuing a `REPORT SCHEMA` command with an `AT` clause.

Syntax Element	Description
AT SCN <i>integer</i>	Specifies an SCN.
AT SEQUENCE <i>integer</i>	Specifies a log sequence number. The integer indicates the time when the specified log was first opened.
THREAD <i>integer</i>	Specifies a redo THREAD number. The integer indicates the time when the thread was first opened.
AT TIME ' <i>date_string</i> '	Specifies a date (see <a href="#">Example 3-20</a> ). The <code>NLS_LANG</code> and <code>NLS_DATE_FORMAT</code> environment variables specify the format for the time.

### **Report Output**

The information that appears in the output is described in the following tables:

- [Table 3-1](#)
- [Table 3-2](#)
- [Table 3-3](#)
- [Table 3-4](#)
- [Table 3-5](#)
- [Table 3-6](#)
- [Table 3-7](#)

**Table 3-1 Report of Database Schema**

Column	Indicates
File	The absolute data file number.
Size (MB)	The size of the file in megabytes.
Tablespace	The tablespace name.
RB segs	For data files only. YES if rollback segments exist in the tablespace and NO if they do not (only if connected to the recovery catalog). If RMAN is not connected to the catalog, then *** is displayed.
Datafile Name	For permanent data files only. The name of the data file.
Maxsize (MB)	For temp files only. The maximum size of the temp file.
Tempfile Name	For temp files only. The name of the temp file.

**Table 3-2 Report of Files Whose Recovery Needs More Than n Days of Archived Logs**

Column	Indicates
File	The absolute file number of a data file that requires more than <i>n</i> days of archived redo log files for recovery.
Days	The number of days of archived redo data required for recovery.
Name	The name of the data file.

**Table 3-3 Report of Files That Need More than n Incrementals During Recovery**

Column	Indicates
File	The absolute file number of a data file that requires more than <i>n</i> incrementals for complete recovery.
Incrementals	The number of incremental backups required for complete recovery.
Name	The name of the data file.

**Table 3-4 Report of Files That Must Be Backed Up to Satisfy n Days Recovery Window**

Column	Indicates
File	The absolute file number of a data file that must be backed up to satisfy a recovery window of <i>n</i> days.
Days	The number of days required for complete recovery.
Name	The name of the data file that requires backup.

**Table 3-5 Report of Files with Fewer Than n Redundant Backups**

Column	Indicates
File	The absolute data file number of a data file with less than <i>n</i> redundant backups.

**Table 3-5 (Cont.) Report of Files with Fewer Than n Redundant Backups**

Column	Indicates
#bkps	The number of backups that exist for this file.
Name	The name of the file.

**Table 3-6 Report of Obsolete Backups and Copies**

Column	Indicates
Type	Whether the object is a backup set, backup piece, proxy copy, or data file copy.
Key	A unique key that identifies this backup in the target database control file.
Completion Time	The time that the backup or copy completed.
Filename/handle	The file name or media handle of the backup or data file copy.

**Table 3-7 Report of Files that Need Backup Due to Unrecoverable Operations**

Column	Indicates
File	The absolute number of the data file that needs a new backup due to unrecoverable operations.
Type Of Backup Required	FULL or INCREMENTAL, depending on which type of backup is necessary to ensure the recoverability of all of the data in this file. If FULL, then create a full backup, level 0 backup, or a data file copy. If INCREMENTAL, then an incremental backup also suffices.
Name	The name of the data file.

## Examples

### Example 3-20 Reporting a Database Schema

This example, which requires a recovery catalog, reports the names of all data files and tablespaces 20 minutes ago.

```
RMAN> REPORT SCHEMA AT TIME 'sysdate-20/1440';
```

```
Report of database schema for database with db_unique_name PROD
```

```
List of Permanent Datafiles
```

```
=====
```

File	Size (MB)	Tablespace	RB segs	Datafile Name
1	450	SYSTEM	YES	/disk1/oradata/prod/system01.dbf
2	197	SYSAUX	YES	/disk1/oradata/prod/sysaux01.dbf
3	20	UNDOTBS	YES	/disk1/oradata/prod/undotbs01.dbf
4	10	CWMLITE	YES	/disk1/oradata/prod/cwmlite01.dbf
5	10	DRSYS	YES	/disk1/oradata/prod/drsys01.dbf
6	10	EXAMPLE	YES	/disk1/oradata/prod/example01.dbf
7	10	INDX	YES	/disk1/oradata/prod/indx01.dbf
8	10	TOOLS	YES	/disk1/oradata/prod/tools01.dbf

```
9 10 USERS YES /disk1/oradata/prod/users01.dbf
```

#### List of Temporary Files

```
=====
File Size(MB) Tablespace      Maxsize(MB) Tempfile Name
-----
1 40 TEMP 32767 /disk1/oradata/prod/temp01.dbf
```

### Example 3-21 Reporting Data Files Needing Incremental Backups

This example reports all data files in the database that require the application of one or more incremental backups to be recovered to their current state:

```
RMAN> REPORT NEED BACKUP INCREMENTAL 1;
```

Report of files that need more than 1 incrementals during recovery

```
File Incrementals Name
-----
1 2 /disk1/oradata/prod/system01.dbf
2 2 /disk1/oradata/prod/sysaux01.dbf
3 2 /disk1/oradata/prod/undotbs01.dbf
4 2 /disk1/oradata/prod/cwmlite01.dbf
5 2 /disk1/oradata/prod/drsys01.dbf
6 2 /disk1/oradata/prod/example01.dbf
7 2 /disk1/oradata/prod/indx01.dbf
9 2 /disk1/oradata/prod/users01.dbf
```

### Example 3-22 Reporting Obsolete Backups and Copies

The following example reports obsolete backups and copies that are redundant according to the current retention policy. The retention policy is set to redundancy 1.

```
RMAN> REPORT OBSOLETE;
```

RMAN retention policy will be applied to the command

RMAN retention policy is set to redundancy 1

Report of obsolete backups and copies

```
Type          Key      Completion Time      Filename/Handle
-----
Archive Log   1022   19-FEB-13           /disk1/prod/arch/archive1_59_614712405.dbf
Archive Log   1023   19-FEB-13           /disk1/prod/arch/archive1_61_614712405.dbf
Archive Log   1024   19-FEB-13           /disk1/prod/arch/archive1_60_614712405.dbf
Archive Log   1025   19-FEB-13           /disk1/prod/arch/archive1_55_614712405.dbf
Backup Set    1032   19-FEB-13
  Backup Piece 1050   19-FEB-13
  /disk2/PROD/backupset/2013_02_19/o1_mf_nnndf_TAG20130219T173839_2xnpmp01_.bkp
Datafile Copy 1073   19-FEB-13
  /disk2/PROD/datafile/o1_mf_system_2xmz515m_.dbf
Backup Set    1035   19-FEB-13
  Backup Piece 1053   19-FEB-13
  /disk2/PROD/backupset/2013_02_19/o1_mf_nnndf_TAG20130219T111434_2xnpozym_.bkp
Datafile Copy 1074   19-FEB-13
  /disk2/PROD/datafile/o1_mf_sysaux_2xmz6zdg_.dbf
Datafile Copy 1075   19-FEB-13
  /disk2/PROD/datafile/o1_mf_undotbs_2xmz7rof_.dbf
Datafile Copy 1076   19-FEB-13
  /disk2/PROD/datafile/o1_mf_cwmlite_2xmz7vrg_.dbf
Datafile Copy 1077   19-FEB-13           /disk2/PROD/datafile/o1_mf_drsys_2xmz7wyc_.dbf
Datafile Copy 1078   19-FEB-13
  /disk2/PROD/datafile/o1_mf_example_2xmz7y5s_.dbf
Datafile Copy 1079   19-FEB-13           /disk2/PROD/datafile/o1_mf_indx_2xmz81jg_.dbf
Datafile Copy 1081   19-FEB-13           /disk2/PROD/datafile/o1_mf_users_2xmz85vo_.dbf
Datafile Copy 1777   20-FEB-13           /disk2/users01.dbf
```

## 3.7 RESET DATABASE

### Purpose

Use the `RESET DATABASE TO INCARNATION` command to reset the incarnation of the target database in the RMAN repository to a previous database incarnation. You are only required to use this command in the following scenarios:

- You use `RESTORE` or `RECOVER` to return the database to an SCN before the current `RESETLOGS` timestamp.
- You use `FLASHBACK DATABASE` to rewind the database to an orphaned database incarnation.

### See Also:

*Oracle Database Backup and Recovery User's Guide* to learn about the circumstances in which it is necessary to use the `RESET DATABASE` command

### Prerequisites

Execute `RESET DATABASE TO INCARNATION` only at the RMAN prompt. RMAN must be connected to a target database.

If RMAN runs in `NOCATALOG` mode, then the target database must be mounted. The mounted control file must contain a record of the specified database incarnation.

If RMAN runs in `CATALOG` mode, then the target database can be mounted or unmounted. If the database is mounted, then the control file must contain a record of the specified database incarnation.

### Usage Notes

When you use RMAN in `NOCATALOG` mode, the `RESET DATABASE TO INCARNATION` command is persistent across RMAN sessions.

### Usage Notes for CDBs

The initial incarnation number of a pluggable database (PDB) is 0. Subsequent incarnation numbers are unique, but not always sequential.

### Syntax

**reset::=**

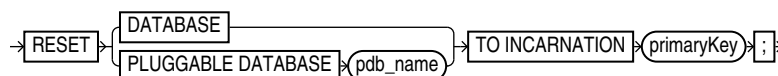

## Semantics

Syntax Element	Description
DATABASE	Specifies the whole multitenant container database (CDB).
PLUGGABLE DATABASE	Specifies the incarnation of the pluggable database (PDB). Use this clause to perform flashback or recovery of a PDB to an orphan PDB incarnation or an ancestor PDB incarnation. You need SYSDBA privileges to run this command. <b>Note:</b> This clause is not supported on a standby database.
<i>primaryKey</i>	Changes the current incarnation to a noncurrent database incarnation specified by the primary key of the DBINC record for the database incarnation. An incarnation key is used to uniquely tag and identify a stream of redo. Run <code>LIST INCARNATION OF DATABASE</code> to obtain possible key values. After you issue <code>RESET DATABASE TO INCARNATION</code> , you can run RMAN commands such as <code>FLASHBACK DATABASE</code> , <code>RESTORE</code> , and <code>RECOVER</code> .

## Examples

**Example 3-23 Resetting RMAN to a Previous Incarnation in NOCATALOG Mode**

In NOCATALOG mode, you must mount a control file that contains information about the incarnation that you want to recover. The following scenario resets the database to an abandoned incarnation of database `trgt` and performs incomplete recovery.

```
CONNECT TARGET / NOCATALOG

# step 1: start and mount a control file that knows about the incarnation to which
# you want to return. Refer to the RESTORE command for appropriate options.
STARTUP NOMOUNT;
RESTORE CONTROLFILE FROM AUTOBACKUP;
ALTER DATABASE MOUNT;

# step 2: obtain the primary key of old incarnation
LIST INCARNATION OF DATABASE trgt;

List of Database Incarnations
DB Key  Inc Key  DB Name  DB ID          STATUS  Reset SCN  Reset Time
-----
1       2       TRGT     1334358386    PARENT  154381    OCT 30 2013 16:02:12
1       116     TRGT     1334358386    CURRENT 154877    OCT 30 2013 16:37:39

# step 3: in this example, reset database to incarnation key 2
RESET DATABASE TO INCARNATION 2;

# step 4: restore and recover the database to a point before the RESETLOGS
RESTORE DATABASE UNTIL SCN 154876;
RECOVER DATABASE UNTIL SCN 154876;

# step 5: make this incarnation the current incarnation and list incarnations:
ALTER DATABASE OPEN RESETLOGS;
LIST INCARNATION OF DATABASE trgt;

List of Database Incarnations
DB Key  Inc Key  DB Name  DB ID          STATUS  Reset SCN  Reset Time
-----
1       2       TRGT     1334358386    PARENT  154381    OCT 30 2013 16:02:12
```

1	116	TRGT	1334358386	PARENT	154877	OCT 30 2013 16:37:39
1	311	TRGT	1334358386	CURRENT	156234	AUG 13 2013 17:17:03

**Example 3-24 Resetting the PDB Incarnation**

This example resets the pluggable database `my_pdb` to an orphan incarnation, 3.

```
RESET PLUGGABLE DATABASE TO INCARNATION 3;
```

## 3.8 RESTORE

**Purpose**

Use the `RESTORE` command to restore, validate, or preview RMAN backups. Typically, you restore backups when a media failure has damaged a current data file, control file, or archived redo log or before performing a point-in-time recovery.

**Prerequisites**

To restore data files to their current location, the database must be started, mounted, or open with the tablespaces or data files to be restored offline.

If you use RMAN in a Data Guard environment, then connect RMAN to a recovery catalog.

If you are performing a trial restore of the production database, then perform either of the following actions before restoring the database in the test environment:

- If the test database uses a fast recovery area that is physically *different* from the recovery area used by the production database, then set `DB_RECOVERY_FILE_DEST` in the test database instance to the new location.
- If the test database uses a fast recovery area that is physically the *same* as the recovery area used by the production database, then set `DB_UNIQUE_NAME` in the test database instance to a different name from the production database.

If you do not perform either of the preceding actions, then RMAN assumes that you are restoring the production database and deletes flashback logs from the fast recovery area because they are considered unusable.

If you restore encrypted databases or tablespaces, then the Oracle keystore must be open before performing the restore operation.

To restore data files in a destination CDB using preplugin backups, the root must be open and you must connect to the root as a common user with the `SYSDBA` or `SYSBACKUP` privilege.

**Usage Notes**

The `RESTORE` command restores full backups, level 0 incremental backups, or image copies. You can restore files to their default location or a different location.

By default, RMAN examines read-only data files to make sure they exist, are readable, and have the correct checkpoint. If any of the conditions is not met, then RMAN restores the files. If all of the conditions are met, then RMAN does not restore the files.

You cannot use a single `RESTORE` command to restore data files belonging to more than one PDB backups.

## Backup Selection

By default, `RESTORE` chooses the most recent backup set or file copy, that is, the file copy or backup set that needs the least media recovery. RMAN only restores backups created on the same type of channels allocated by the `RESTORE` command. For example, if you made backups of a data file with `DISK` and `sbt` channels, and if only a `DISK` channel is allocated for the `RESTORE` command, then RMAN does not restore the `sbt` backups. If you do not manually allocate channels, then RMAN allocates all automatic channels that it possibly needs, subject to any restrictions imposed by the `DEVICE TYPE` option.

In an Oracle RAC configuration, RMAN automatically restores backups, control file copies, and data file copies from channels that can read the files on tape or a local file system. For example, if channel `ch1` connected to `inst1` can read log 1000 from its tape drive, but channel `ch2` connected to `inst2` cannot read the same log from its tape drive, then `ch2` cannot participate in restoring the log and so `ch1` restores the log. Autolocation is automatically enabled when the channels have different `PARMS` or `CONNECT` settings.

If data file names are symbolic links, then the control file stores the file names of the link files but RMAN performs I/O on the data files pointed to by the link files. If a link file is lost and you restore a data file without re-creating the symbolic link, then RMAN restores the data file to the location of the link file rather than to the location pointed to by the link file.



### See Also:

*Oracle Database Backup and Recovery User's Guide* for details on restore failover

## Restore Operations for Sparse Databases

To restore sparse databases, the `COMPATIBLE` initialization parameter must be set to 12.2 or higher. You can perform a sparse restore of a data file, tablespace, PDB, or a whole CDB.

By default, RMAN determines the most appropriate backup (backup set or image copy) of the specified object. The selected backup may be a sparse backup or a non-sparse backup. To specify that a sparse backup must be used, include the `FROM SPARSE` clause in the `RESTORE` command. To specify that a non-sparse backup must be used, include the `FROM NONSPARSE` clause in the `RESTORE` command.

For non-temp sparse files, if the sparse data file was originally on a sparse disk group but the alternate location specified by `DB_CREATE_FILE_DEST` is a non-sparse disk group, then RMAN creates the data file in its original disk group (instead of the diskgroup specified by `DB_CREATE_FILE_DEST`).

## Restore Operations Using Encrypted Backup Sets

As explained in "[Encryption of Backup Sets](#)", how RMAN handles encrypted backup sets during restore operations depends on the encryption mode with which the backup was created. You can use `CONFIGURE` and `SET` to manage the RMAN backup encryption settings for your database. Note the following restore considerations:

- For transparent-mode encrypted backups, the required passwords must be available in the Oracle software keystore. The same keystore used when creating the backup must be open and available when restoring it. If a password-based keystore was used while creating the backups, then you must use `SET DECRYPTION WALLET OPEN IDENTIFIED BY` to provide the password used to open the keystore.



- For password-mode encrypted backups, the required passwords must be provided with `SET DECRYPTION`.
- For dual-mode encrypted backups, the required passwords must be available in the Oracle software keystore or provided with `SET DECRYPTION`.

 **Note:**

Keystore-based encryption is more secure than password-based encryption because no passwords are involved. Use password-based encryption only when absolutely necessary because your backups must be transportable.

### Restore Failover

If a backup piece, image copy or proxy copy is inaccessible or if a block is corrupted, then RMAN performs restore failover. The `RESTORE` command automatically looks for another usable copy of a backup or image copy on the same device and other devices. If no usable copies are available, then RMAN searches for previous backups. RMAN continuously searches for previous usable backups until it has exhausted all possibilities. RMAN automatically uses eligible backups from previous database incarnations if required.

If you are restoring a data file for which no backups are available, then RMAN creates an empty data file with the checkpoint change as creation SCN. During recovery, all archived redo log files back to the creation of the data file are restored, and all changes during the history of the data file are reapplied to re-create its contents.

 **See Also:**

"[Encryption of Backup Sets](#)" and the extended discussion in *Oracle Database Backup and Recovery User's Guide*

### Location of Restored Data Files

If you restore data files to the default location, then RMAN overwrites files with the same file names. By default, RMAN does not restore a data file if it is in the correct place and its header contains the expected data. RMAN does not scan the data file body for corrupt blocks.

If RMAN detects that the default file name cannot be used (for example, the file may be an Oracle-managed file or on an Automatic Storage Management disk group), then RMAN attempts to create a new file in the same location or disk group.

RMAN restores data files to the location currently stored in the recovery catalog. This default behavior eliminates problems with restoring data files to locations that may have become obsolete since the time of the original backup. It also means that if you have changed the location of the data files from their original backup location, that RMAN restores the files to the most current or changed location.

To restore files to a nondefault location, use `SET NEWNAME` commands to rename the restored files and then use a `SWITCH` command to make the restored files current (as illustrated in [Example 3-26](#)). If you do not issue `SWITCH` commands, then RMAN

considers the restored files as valid copies for use in future restore operations. [Table 3-8](#) describes the behavior of the `RESTORE`, `SET NEWNAME`, and `SWITCH` commands.

**Table 3-8 SET NEWNAME, SWITCH, and RESTORE**

SET NEWNAME Run	SWITCH Run	RESTORE Behavior
No	N/A	RMAN restores the files to the most recent location stored in the recovery catalog.
Yes	Yes	RMAN restores the files to the path names specified by <code>SET NEWNAME</code> . RMAN replaces the current data file names in the control file with the names of the restored files. RMAN records the data files with the old names as data file copies.
Yes	No	RMAN restores the files to the path names specified by <code>SET NEWNAME</code> . RMAN does not update the current data file names in the control file. The restored files are listed in the RMAN repository as data file copies.

Because temp files cannot be backed up and because no redo is ever generated for them, RMAN never restores or recovers temp files. RMAN does track the names of temp files, but only so that it can automatically re-create them when needed.

#### RMAN Behavior When Restoring Control Files

The behavior of RMAN when restoring control files depend on a variety of factors, which are summarized in [Table 3-9](#). Required commands and options for restoring autobackups are summarized in [Table 3-10](#).

**Table 3-9 RESTORE CONTROLFILE Scenarios**

RMAN Connection	RESTORE CONTROLFILE;	RESTORE CONTROLFILE FROM AUTOBACKUP;	RESTORE CONTROLFILE ... TO 'filename';	RESTORE CONTROLFILE ... FROM 'media_handle' or TAG 'user_tag';
No catalog, target database started in NOMOUNT state	Error. Must specify FROM AUTOBACKUP .	Restores to CONTROL_FILES locations. See <a href="#">Table 3-10</a> for required commands and options.	Must specify FROM AUTOBACKUP. Restores only to <i>filename</i> .	First run <code>SET DBID</code> . Restores from specified file (cannot restore from TAG). If TO ' <i>filename</i> ' not used, restores to all CONTROL_FILES locations.
No catalog, target database mounted or open	Error. Must use TO ' <i>filename</i> ', where <i>filename</i> is not in CONTROL_FILES list.	Error. Must use TO ' <i>filename</i> ', where <i>filename</i> is not in CONTROL_FILES list.	Restores only to <i>filename</i> , where <i>filename</i> is not in CONTROL_FILES list.	RMAN issues error RMAN-06496. Use TO ' <i>filename</i> ' instead.

Table 3-9 (Cont.) RESTORE CONTROLFILE Scenarios

RMAN Connection	RESTORE CONTROLFILE;	RESTORE CONTROLFILE FROM AUTOBACKUP;	RESTORE CONTROLFILE ... TO 'filename';	RESTORE CONTROLFILE ... FROM 'media_handle' or TAG 'user_tag';
Catalog, target database started in NOMOUNT state	Restores to CONTROL_FILES locations. Run SET DBID only if DB_NAME not unique in catalog.	Only use with recovery catalog for testing.	Restores only to <i>filename</i> , where <i>filename</i> is not in CONTROL_FILES list.	Restores from specified file. If TO 'filename' not used, restores to all CONTROL_FILES locations.
Catalog, target database mounted or open	Error. Must use TO 'filename', where <i>filename</i> is not in CONTROL_FILES list.	Do not use with recovery catalog.	Restores only to <i>filename</i> , where <i>filename</i> is not in CONTROL_FILES list.	RMAN issues error RMAN-06496. Use TO 'filename' instead.

If you use RMAN in a Data Guard environment, then RMAN transparently converts primary control files to standby control files and vice versa. RMAN automatically updates file names for data files, online redo logs, standby redo logs, and temp files when you issue `RESTORE` and `RECOVER`. The recovery catalog always contains the correct information about the backup file names for each database, as explained in "[RMAN Backups in a Data Guard Environment](#)".

#### Control File and Server Parameter File Autobackup Options

When restoring an autobackup, the commands and options that you use depend on the autobackup type (control file or server parameter file) and location (inside or outside fast recovery area). The options are summarized in [Table 3-10](#).

Table 3-10 RESTORE ... FROM AUTOBACKUP

Restore Object	Autobackup Location	Run SET DBID?	Specify RECOVERY AREA on RESTORE?	Specify DB_NAME or DB_UNIQUE_NAME on RESTORE?	Run SET CONTROLFILE AUTOBACKUP FORMAT?
SPFILE	Recovery area	No	Yes	Yes	No
SPFILE	Outside recovery area	Yes	No	No	Only if autobackup is not in default location
Control file	Recovery area	No	Only if autobackup is in noncurrent recovery area	Only if autobackup is in noncurrent recovery area and uses a noncurrent DB_UNIQUE_NAME	No
Control file	Outside recovery area	Yes	No	No	Only if autobackup is not in default location

## Restoring Control Files From Archived Backups in NOCATALOG Mode

You can offload backups stored on disk either to tape or Oracle Cloud. When control file autobackup is enabled, and you use one of the following commands to archive disk backups to tape or Oracle Cloud, RMAN includes a backup of the latest control file to tape or Oracle Cloud:

- `BACKUP BACKUPSET ALL`
- `BACKUP RECOVERY AREA`
- `BACKUP DATAFILE COPY ALL`

To restore these backups, when a recovery catalog is not used, you must configure one or more disk and SBT channels (for tape or Oracle Cloud).

See [Example 3-30](#).

## Restoring Data Files and Control Files Using Files from a Remote Host

Starting with Oracle Database 12c, you can restore a database, data files, control files, tablespaces, or an spfile using files from a remote database. RMAN connects to the remote database and transfers the required files, over the network, to the target database using backup sets. This is very useful in a Data Guard environment. You can restore data files on a primary database by connecting to a standby database over the network. You can also restore data files on a standby database by connecting to the primary database.

While restoring files from a remote host over the network, you must use `FROM SERVICE` to specify the service name of the remote host from which the files are obtained. Optionally, use `SECTION SIZE` to restore files from the source database as multisection backup sets. You can compress the transferred files by specifying the `USING COMPRESSED BACKUPSET`.

To encrypt the files being transferred from the source database, use the `SET ENCRYPTION` command before the `RESTORE` command. You can also use `SET COMPRESSION ALGORITHM` to specify the algorithm used to compress the backup sets before transferring them over the network.

### Prerequisites for Restoring Files Using a Remote Host

- The password file on the source database and the target database must be the same.
- The `tnsnames.ora` file in the target database must contain an entry that corresponds to the remote database.

### Syntax

**`restore::=`**

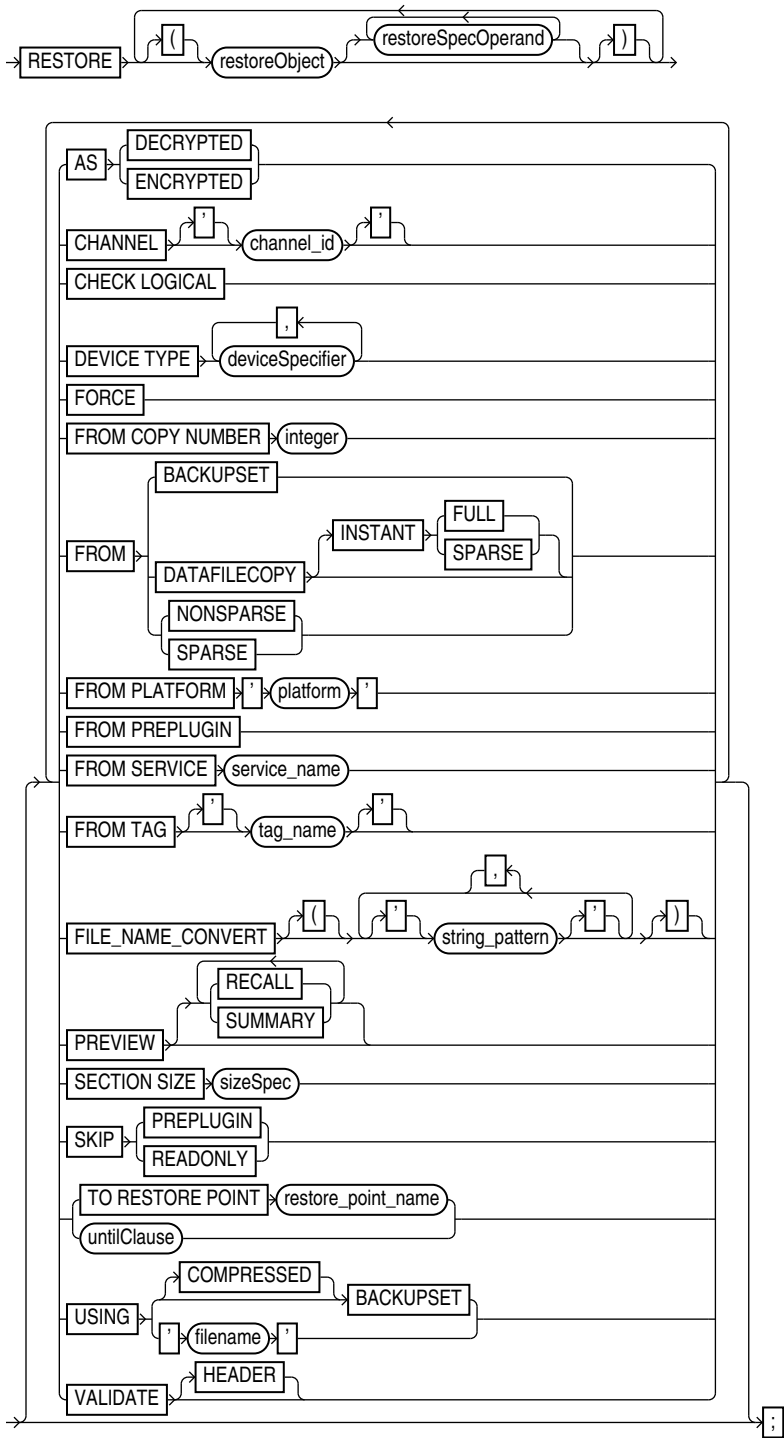

(restoreObject::=, restoreSpecOperand::=, deviceSpecifier::=, untilClause::=)

**restoreObject::=**

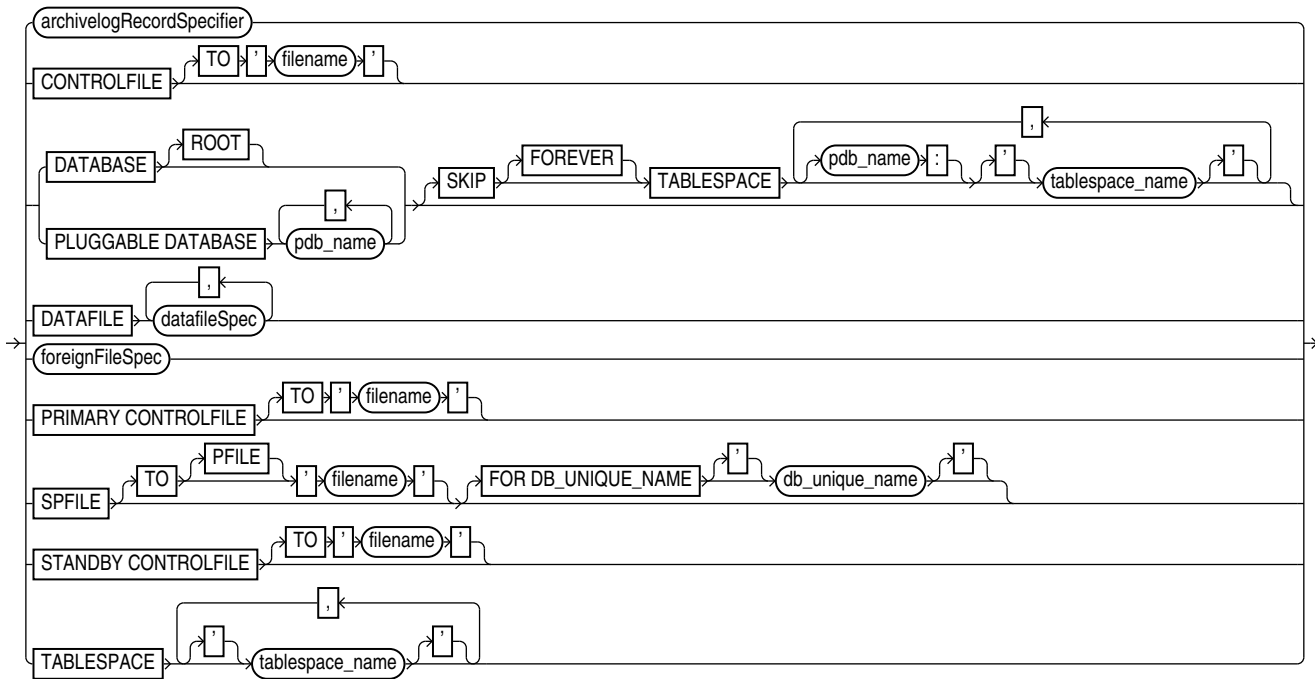

(`archivelogRecordSpecifier::=`, `datafileSpec::=`, `foreignFileSpec::=`)

**`restoreSpecOperand::=`**

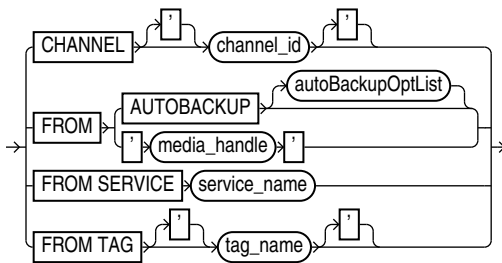

**`autoBackupOptList::=`**

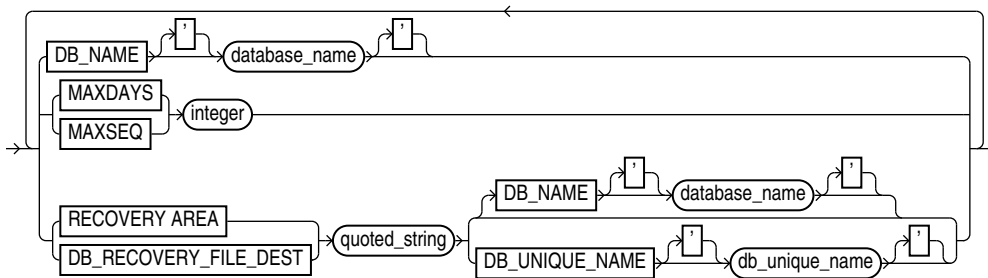

**Semantics**

**`restore`**

This clause enables you to select which files you want to restore and specify parameters that control the behavior of the restore operation.

Syntax Element	Description
<a href="#">restoreObject</a>	Specifies the files to be restored.
<a href="#">restoreSpecOperand</a>	Specifies options for the <a href="#">restoreObject</a> clause.
AS ENCRYPTED	<p>Restores backups of a database or specified tablespaces by encrypting the restored data file blocks. This is useful when you want use existing RMAN backups to move an on-premises database to Oracle Cloud. The on-premises database and its backups are unencrypted. Restoring these backups using AS ENCRYPTED ensures that the Oracle Cloud database is encrypted. RMAN uses the database key to encrypt the data.</p> <p>The target database must be mounted. The wallet must be created and open before you run the RESTORE . . . AS ENCRYPTED command.</p> <p>To use this clause, the COMPATIBLE parameter of the target database must be set to 12.2 or higher and the backups used must be created with COMPATIBLE set to 11.2 or higher.</p> <p><b>Note:</b> This clause is supported only when restoring whole databases or tablespaces.</p> <p><b>Note:</b> You cannot use the DATAFILE, FOREIGN DATAFILE, ARCHIVELOG, FOREIGN ARCHIVELOG, SPFILE, and CONTROLFILE clauses with AS ENCRYPTED.</p>
AS DECRYPTED	<p>Restores backups of an encrypted database or tablespace such that the restored data blocks are not encrypted. This is useful when moving a database on Oracle Cloud to an on-premises environment by using existing RMAN backups. Encryption is used for data files and backups to Oracle Cloud. You can choose to restore the backups of the encrypted database or tablespace that were created on Oracle Cloud and create an on-premises database that does not use encryption. The target database must be mounted.</p> <p>You can only restore tablespaces encrypted with the database key as unencrypted backups. This includes tablespaces that were previously restored with encryption or tablespaces created on Oracle Cloud without an explicit encryption clause. Tablespaces that are created as encrypted or that are explicitly rekeyed after a restore operation with encryption will not be decrypted.</p> <p>To use this clause, the COMPATIBLE parameter must be set to 12.2 or higher and the backups must be created with COMPATIBLE set to 12.2 or higher.</p> <p><b>Note:</b> It is recommended that you do not decrypt the SYSTEM and UNDO tablespaces after they have been encrypted. This would result in rollback segments for encrypted tablespaces being decrypted.</p> <p><b>Note:</b> This clause is supported only when restoring whole databases or tablespaces.</p> <p><b>Note:</b> You cannot use the DATAFILE, FOREIGN DATAFILE, ARCHIVELOG, FOREIGN ARCHIVELOG, SPFILE, and CONTROLFILE clauses with AS DECRYPTED.</p>
CHANNEL <i>channel_id</i>	Refer to the <a href="#">restoreSpecOperand</a> clause.

Syntax Element	Description
CHECK LOGICAL	<p>Tests data and index blocks that pass physical corruption checks for logical corruption, for example, corruption of a row piece or index entry. If RMAN finds logical corruption, then it logs the block in the alert log and server session trace file.</p> <p>If the total number of physical and logical corruptions detected in a file is less than its <a href="#">SET MAXCORRUPT</a> setting, then the RMAN command completes and the database populates the <code>V\$DATABASE_BLOCK_CORRUPTION</code> view with corrupt block ranges. If <code>MAXCORRUPT</code> is exceeded, then the command terminates without populating the views.</p> <p>When restoring a backup data file, RMAN honors the <code>DB_BLOCK_CHECKSUM</code> initialization parameter setting. RMAN clears the checksum if <code>DB_BLOCK_CHECKSUM</code> is set to <code>false</code>. If set to <code>typical</code>, then RMAN verifies the checksum when restoring from the backup and writing to the data file. If the initialization parameter <code>DB_BLOCK_CHECKSUM=typical</code>, and if <code>MAXCORRUPT</code> is not set, then specifying <code>CHECK LOGICAL</code> detects all types of corruption that are possible to detect.</p> <p><b>Note:</b> The <code>MAXCORRUPT</code> setting represents the total number of physical and logical corruptions permitted on a file.</p>
DEVICE TYPE <a href="#">deviceSpecifier</a>	<p>Allocates automatic channels for the specified device type only. For example, if you configure automatic disk and tape channels, and issue <code>RESTORE . . . DEVICE TYPE DISK</code>, then RMAN allocates only disk channels. You must configure a device type by using <a href="#">CONFIGURE</a> (except for <code>DISK</code>, which is preconfigured) before specifying the <code>DEVICE TYPE</code> option.</p> <p><b>Note:</b> You cannot manually allocate channels within a <a href="#">RUN</a> block and then run <code>RESTORE</code> with the <code>DEVICE TYPE</code> clause.</p> <p><b>See Also:</b> <a href="#">deviceSpecifier</a></p>
FORCE	<p>Overrides the restartable restore feature and restores all files regardless of whether they must be restored. If you do not specify <code>FORCE</code>, then RMAN restores a file only if its header information does not match the information in the control file.</p>
FROM COPY NUMBER <i>integer</i>	<p>Specifies the copy number of the backup piece within a set of duplexed backup pieces. If no duplexing was performed, the copy number is 1. Otherwise, the copy number value ranges from 2 to 4.</p>
FROM BACKUPSET	<p>Restores from backup sets only. By default <code>RESTORE</code> chooses the file copy or backup set that needs the least media recovery.</p> <p>If you use the <code>FROM BACKUPSET</code> option, then channels for the appropriate type of storage devices must be allocated for the backup sets that must be restored. For example, if needed backups are only available on tape, and no <code>sbt</code> channels have been allocated, then RMAN cannot find a candidate backup set to restore, and the <code>RESTORE</code> command fails.</p>
FROM DATAFILECOPY	<p>Restores data file copies only. By default <code>RESTORE</code> chooses the file copy or backup set that needs the least media recovery. If you use the <code>FROM DATAFILECOPY</code> option, then the allocated channels must be of <code>DEVICE TYPE DISK</code>.</p>
FROM SPARSE	<p>Restores data files from the appropriate sparse backup set or image copy of the selected backup. The restored data files are sparse. If no sparse backup is available for this operation, the restore will fail.</p> <p>The database compatibility parameter must be set to 12.2 or higher to perform <code>RESTORE FROM SPARSE</code>.</p>



Syntax Element	Description
FROM NONSPARSE	Restores data files from the appropriate non-sparse backup. This selected backup can be in either the backup set format or image copy format. The restored data files are non-sparse. If no non-sparse backup is available for this operation, the restore will fail.
INSTANT FULL	This clause is reserved for a future release.
INSTANT SPARSE	This clause is reserved for a future release.
FROM PLATFORM <i>platform</i>	<p>Specifies the name of the platform on which the cross platform backup was created. Cross-platform data transportation is supported starting with Oracle Database 12c Release 1 (12.1). This clause must be accompanied by a <i>foreignFileSpec</i> that specifies the backup sets that contain the data to be restored. The FROM PLATFORM clause is optional. You can restore a cross-platform backup by specifying only a <i>foreignFileSpec</i>. However, if you specify a platform name using FROM PLATFORM, the name must match the platform identifier stored in the cross-platform backup header.</p> <p>To perform cross-platform tablespace transport by connecting over the network to a remote database, use the FROM PLATFORM clause with the FROM SERVICE clause. RMAN then creates the required backup sets on the source database, transfers them to the destination database, and then restores them on the destination.</p>
FROM PREPLUGIN	Restores data files and archived redo log files in the target CDB by using preplugin backups that were created before a source non-CDB or PDB was plugged in to the target CDB as a PDB.
FROM SERVICE <i>service_name</i>	<p>Restores data files, control files, or the spfile on the target database using files transferred over the network from a remote database. <i>service_name</i> specifies the service name of the remote database.</p> <p>To perform cross-platform tablespace transport by connecting over the network to a remote database, use the FROM PLATFORM clause with the FROM SERVICE clause. RMAN connects to the source database, creates the required backups, transfers them to the destination, and then restores the backups on the destination.</p>
FROM TAG <i>tag_name</i>	Refer to the <a href="#">restoreSpecOperand</a> clause.
FILE_NAME_CONVERT <i>string_pattern</i>	<p>Specifies how Oracle Database file names on the source CDB map to the corresponding files on the destination CDB during cross-platform transport of a PDB to a destination CDB.</p> <p>Specifies pairs of strings used to convert the file names. You can use as many pairs of source and destination replacement strings as required. For example, you can set the string pattern to a value such as:</p> <pre>FILE_NAME_CONVERT = ('str1','str2','str3', 'str4' ...)</pre>

Syntax Element	Description
PREVIEW	<p>Reports—but does not restore—the backups and archived redo log files that RMAN could use to restore and recover the database to the specified time. RMAN queries the metadata and does not actually read the backup files.</p> <p>The <code>RESTORE ... PREVIEW</code> output is in the same format as the <code>LIST BACKUP</code> output (see <a href="#">Example 3-32</a>).</p> <p>Some media managers provide status information to RMAN about which backups are offsite. Offsite backups are stored in a remote location, such as a secure storage facility, and cannot be used without retrieving media.</p> <p>Offsite backups are marked as <code>AVAILABLE</code> in the RMAN repository even though the media must be retrieved from storage before the backup can be restored. If RMAN attempts to restore a offsite backup, then the restore operation fails. <code>RESTORE ... PREVIEW</code> can identify backups needed for a <code>RESTORE</code> operation that are stored on media that requires retrieval. The output indicates whether backups are stored offsite.</p> <p>If a needed backup is stored offsite, but the media manager does not support offsite backups, then your options are:</p> <ul style="list-style-type: none"> <li>• Use <code>CHANGE ... UNAVAILABLE</code> to prevent RMAN from selecting the needed offsite backups, and attempt the <code>RESTORE ... PREVIEW</code> operation again to determine whether RMAN selects another offsite backup. When RMAN does not select any offsite backups, you can perform the restore operation.</li> <li>• Use <code>RESTORE ... PREVIEW</code> with the <code>RECALL</code> option.</li> </ul> <p><b>See Also:</b> <a href="#">LIST</a>, specifically the <code>BACKUPS</code> and <code>SUMMARY</code> options, and the <code>RECOVER ... VALIDATE HEADER</code> command</p>
RECALL	<p>Instructs the media manager to retrieve the backup media needed for the specified restore operation from offsite storage (see <a href="#">Example 3-33</a>).</p> <p>When restoring backups that are stored in archive storage in Oracle Cloud Infrastructure Classic, use this option to first recall backups before you restore them.</p> <p><b>Note:</b> This option only works if your media manager supports this functionality. You can use <code>RESTORE ... PREVIEW</code> periodically to monitor whether the needed backups are stored locally again.</p>
SUMMARY	<p>Summarizes the backups that RMAN would restore. The output is in the same format as the output of the <code>LIST BACKUPS ... SUMMARY</code> command.</p>
SECTION SIZE	<p>Restores a multi-section backup.</p>
SKIP PREPLUGIN	<p>Excludes preplugin data files.</p>
SKIP READONLY	<p>Does not restore read-only files.</p>
TO RESTORE POINT <i>restore_point_name</i>	<p>Specifies a restore point, with the SCN at which the restore point was created as the upper, inclusive limit. Because the limit is inclusive, RMAN selects only files that it can use to restore files up to <i>and including</i> the SCN corresponding to the restore point.</p>
<a href="#">untilClause</a>	<p>Limits the selection to backup sets or file copies that are suitable for a point-in-time recovery to the specified time, SCN, or log sequence number.</p> <p>In the absence of any other criteria, RMAN selects the most current file copy or backup set to restore. The time specified in the <code>UNTIL</code> clause must fall within the current database incarnation.</p> <p><b>See Also:</b> <a href="#">untilClause</a></p>

Syntax Element	Description
USING [COMPRESSED] BACKUPSET	Specifies that the files being restored, over the network, must be transferred from the remote database as compressed backup sets. By default, RMAN transfers files as backup sets. Therefore, even when you omit the USING BACKUPSET clause, the files are transferred as backup sets. By default, compression is performed by using the compression algorithm that is set in the RMAN configuration. You can use a different compression algorithm by executing the SET COMPRESSION ALGORITHM command before executing the RESTORE command.
VALIDATE	<p>RMAN identifies which backup sets, data file copies, and archived redo log files must be restored, and then validates them (see <a href="#">Example 3-34</a>). No files are restored.</p> <p>For files on both disk and tape, RMAN reads all blocks in the backup piece or image copy. RMAN also validates offsite backups. The validation is identical to a real restore operation except that RMAN does not write output files.</p> <p><b>Note:</b> If you use RESTORE with the VALIDATE option, then the database can be open with data files online.</p> <p><b>See Also:</b> <a href="#">VALIDATE</a></p>
HEADER	<p>Reports and validates—but does not restore—the backups that RMAN could use to restore to the specified time.</p> <p>When you specify this option, RMAN performs the same functions as when you run RESTORE with the <a href="#">PREVIEW</a> option. However, in addition to listing the files needed for restore and recovery, RMAN validates the backup file headers to determine whether the files on disk or in the media management catalog correspond to the metadata in the RMAN repository.</p> <p><b>See Also:</b> The descriptions of the RESTORE <a href="#">PREVIEW</a> option and the <a href="#">RECOVER ... VALIDATE HEADER</a> option</p>

### *restoreObject*

This subclause specifies the objects to be restored: control files, data files, archived redo log files, or the server parameter file. RMAN does not support backup and recovery of the change tracking file. RMAN re-creates the change tracking file after database restore and recovery; the next incremental backup after any recovery can use the file. Thus, restore and recovery has no user-visible effect on change tracking.

Syntax Element	Description
<a href="#">archivelogRecordSpecifier</a>	<p>Restores the specified range of archived redo log files.</p> <p>The default restore location is <code>DB_RECOVERY_FILE_DEST</code> (if one of <code>LOG_ARCHIVE_DEST_n</code> is configured to <code>USE_DB_RECOVERY_FILE_DEST</code> either implicitly or explicitly). Otherwise, the default restore file names are constructed with the <code>LOG_ARCHIVE_FORMAT</code> and <code>LOG_ARCHIVE_DEST_1</code> initialization parameters of the target database. These parameters combine in a port-specific fashion to derive the name of the restored log. You can override the default location with the <code>SET ARCHIVELOG DESTINATION</code> command.</p> <p>Because the <code>RECOVER</code> command automatically restores archived redo log files as needed, you seldom need to restore logs manually. Possible reasons for manually restoring archived redo log files are to speed up recovery, to stage the logs to multiple destinations, or to analyze the log contents after a point-in-time recovery. To restore logs from a previous incarnation without shutting down the database, you can use <code>RESTORE ARCHIVELOG</code> with:</p> <ul style="list-style-type: none"> <li>• ... FROM SCN</li> <li>• ...SCN BETWEEN... AND</li> <li>• FROM SCN ... INCARNATION &lt;integer&gt;</li> <li>• FROM SCN... INCARNATION ALL</li> </ul> <p><b>Note:</b> The database can be started, mounted, or open for this operation.</p> <p><b>See Also:</b> <a href="#">archivelogRecordSpecifier</a>.</p>
CONTROLFILE	<p>Restores either a standby or backup control file depending on the target database role.</p> <p>If the control file is lost, then restore the control file (see <a href="#">Table 3-9</a>) and restore the database after mounting the restored control file. You must always run the <code>RECOVER</code> command after mounting a restored control file and you must open the database with the <code>RESETLOGS</code> option.</p> <p><b>Note:</b> If the target database is not mounted, and if RMAN is not connected to a recovery catalog, then you must specify the <code>FROM AUTOBACKUP</code> clause with <code>RESTORE CONTROLFILE</code>. If the autobackup is in a nondefault format, then first use the <code>SET CONTROLFILE AUTOBACKUP FORMAT</code> command to specify the format. If the target database is mounted or open, then you must specify the <code>TO filename</code> clause with <code>RESTORE CONTROLFILE</code>.</p> <p>When you run <code>RESTORE</code> with a backup control file while connected to a recovery catalog (see <a href="#">Example 3-27</a>), RMAN automatically updates the control file to reflect the structure of the restored database based on the metadata in the catalog.</p>
TO 'filename'	<p>Restores the control file to the specified file name.</p> <p><a href="#">Table 3-9</a> explains RMAN behavior when restoring the control file with the <code>TO</code> clause.</p>
APPLICATION ROOT DATABASE	<p>Specifies all data files in the application root.</p> <p>Connect to the CDB root as a common user with the <code>SYSDBA</code> or <code>SYSBACKUP</code> privilege. Or, connect to application root as an application common user with the <code>SYSDBA</code> or <code>SYSBACKUP</code> privilege.</p>

Syntax Element	Description
DATABASE	<p>Restores all data files in the a whole CDB or a PDB, except those that are offline. By default, RMAN restores data files in read-only tablespaces. To restore data files in a CDB, connect to the root as a common user with the <code>SYSDBA</code> or <code>SYSPRIV</code> privilege. To restore data files in a single PDB, connect to the PDB as a common user or local user with the <code>SYSDBA</code> or <code>SYSPRIV</code> privilege.</p> <p>In an application container, restores the entire application container. This includes the application root and all application PDBs that belong to this application root. You connect to the application root as an application common user with the <code>SYSDBA</code> or <code>SYSPRIV</code> privilege.</p> <p>Unlike <code>BACKUP DATABASE</code>, <code>RESTORE DATABASE</code> does <i>not</i> automatically include the control file and the server parameter file—you must issue additional <code>RESTORE CONTROLFILE</code> and <code>RESTORE SPFILE</code> commands to restore these files.</p> <p><b>Note:</b> To restore offline data files you must use <code>RESTORE DATAFILE</code> or <code>RESTORE TABLESPACE</code>.</p>
DATABASE ROOT	<p>Restores all online data files belonging to the root. Connect to the root as a common user with the <code>SYSDBA</code> or <code>SYSPRIV</code> privilege..</p> <p>In an application container, restores online data files belonging to the application root and all application PDBs. Connect to the application root as an application common user with the <code>SYSDBA</code> or <code>SYSPRIV</code> privilege.</p>
PLUGGABLE DATABASE <i>pdb_name</i>	<p>Restores all data files belonging to the specified PDB. No other PDBs are affected; they can remain open and operational. Use a comma-separated list to restore multiple PDBs. Connect to the root as common user with the <code>SYSDBA</code> or <code>SYSPRIV</code> privilege.</p> <p>In an application container, connect to the CDB root as a common user with the <code>SYSDBA</code> or <code>SYSPRIV</code> privilege and specify the name of the application root in <i>pdb_name</i> to restore data files belonging to the application root and all application PDBs.</p> <p>To restore all data files belonging to a specified application PDB, connect to the application root as an application common user with the <code>SYSDBA</code> or <code>SYSPRIV</code> privilege. To restore files for multiple application PDBs, specify a common-separated list of application PDB names.</p>
SKIP [FOREVER] TABLESPACE <i>tablespace_name</i>	<p>Excludes the specified tablespaces from the restore operation. This option is useful to avoid restoring tablespaces containing temporary data. In a CDB, refers to a tablespace in the root when connected to the root, and refers to a tablespace in a PDB when connected directly to the PDB.</p> <p>Specifying the <code>FOREVER</code> keyword does not change the behavior of <code>SKIP</code>. The <code>FOREVER</code> keyword exists solely to maintain compatible syntax between <code>RESTORE SKIP FOREVER</code> and <code>RECOVER SKIP FOREVER</code>.</p>
SKIP TABLESPACE <i>pdb_name:tablespace_name</i>	<p>Excludes the specified tablespaces in the named PDB from the restore operation. This syntax is required only when connected to the root. When connected directly to a PDB, use <code>TABLESPACE tablespace_name</code>.</p>
TABLESPACE <i>pdb_name:tablespace_name</i>	<p>In a CDB, restores all data files belonging to the specified PDB. No other PDBs are affected; they can remain open and operational. Use a comma separated list to restore multiple PDBs. Connect to the root as described in <code>CONNECT</code>.</p> <p>This syntax is required only when connected to the root. When connected directly to a PDB, use <code>TABLESPACE tablespace_name</code>.</p>

Syntax Element	Description
DATAFILE <a href="#">datafileSpec</a>	<p>Restores the data files specified by file name or absolute data file number (see <a href="#">Example 3-26</a>).</p> <p><b>Note:</b> Do not specify a data file more than once in a restore job. For example, the following command is invalid because data file 1 is both specified explicitly and implied by the SYSTEM tablespace:</p> <pre>RESTORE TABLESPACE SYSTEM DATAFILE 1;</pre> <p><b>See Also:</b> <a href="#">datafileSpec</a></p>
<a href="#">foreignFileSpec</a>	<p>Restores a cross-platform backup that uses backup sets. Specifying <a href="#">foreignFileSpec</a> is mandatory when you perform a cross-platform restore operation. This clause specifies the data that must be restored (data files, tablespaces, or entire database) and the backup sets that contain the data to be restored. The cross-platform backup that is being restored can consist of multiple backup sets or multiple backup pieces.</p> <p>Use the BACKUPSET syntax to specify the backup set to be restored. To restore data files, use ALL FOREIGN DATAFILES or FOREIGN DATAFILE. To restore tablespaces, use FOREIGN TABLESPACE. To restore an entire database, use FOREIGN DATABASE.</p> <p>To plug the restored tablespaces in to the destination database, you use the export dump file containing the tablespace metadata that was created along with the backup. Use DUMP FILE to indicate that the backup contains an export dump file and BACKUPSET to specify the backup set that contains the export dump file.</p> <p><b>Note:</b> This clause can be used only to restore data that was backed up using backup sets. It cannot be used for backups created as image copies.</p> <p><b>See Also:</b> <a href="#">foreignFileSpec</a></p>
FOREIGN PLUGGABLE DATABASE <i>pdb_name</i> FROM SERVICE	
PRIMARY CONTROLFILE	<p>Restores a control file for a primary database in a Data Guard environment. RMAN restores either a normal or standby control file as appropriate, depending on the most recent database role known to the recovery catalog (<a href="#">RC_SITE</a>.DATABASE_ROLE) for the target database. The purpose of this option is to override the default setting in cases where the most recent database role is out-of-date.</p> <p>Assume that you perform a switchover from primary database <i>dgny</i> to standby database <i>dgsf</i>, so that <i>dgsf</i> is the new primary database. You want to restore a control file on <i>dgsf</i>, but the recovery catalog was not resynchronized and still shows <i>dgsf</i> as a standby database. In this case, you can specify PRIMARY CONTROLFILE to override the default RMAN behavior and restore a normal control file.</p>

Syntax Element	Description
SPFILE	<p>Restores a primary or standby server parameter file to the location from which it was backed up. RMAN cannot overwrite a server parameter file currently in use by the target database.</p> <p>By default RMAN restores the most current server parameter file. Specify the UNTIL or TAG options to restore older versions of the server parameter file.</p> <p>If the server parameter file is lost, then connect RMAN to the target database (and recovery catalog if used) and run <code>SET DBID</code>. Run <code>STARTUP FORCE NOMOUNT</code> before running <code>RESTORE SPFILE</code>. Then run <code>STARTUP FORCE</code> to restart the database instance with the restored server parameter file.</p> <p><b>Note:</b> If the target database is not mounted, and if RMAN is not connected to a recovery catalog, then you must specify the <code>FROM AUTOBACKUP</code> clause with <code>RESTORE SPFILE</code>. If the autobackup is in a nondefault format, then first use the <code>SET CONTROLFILE AUTOBACKUP FORMAT</code> command to specify the format. If the target database is started, mounted, or open, and if the database was started with a server parameter file, then you must specify the <code>TO filename</code> clause with <code>RESTORE SPFILE</code>.</p>
TO [PFILE] 'filename'	<p>Restores a primary or standby server parameter file to the location specified by the TO clause. Specify PFILE to save the server parameter file as a text-based initialization parameter file.</p>
FOR DB_UNIQUE_NAME db_unique_name	<p>Specifies the DB_UNIQUE_NAME for the target database when the instance is not started. This parameter is only useful in a Data Guard environment.</p> <p>When FOR DB_UNIQUE_NAME is specified, RMAN can locate the correct RMAN configurations for the host on which the SPFILE is being restored and use them to access backup devices. Otherwise, RMAN cannot choose the correct channel configurations and returns an RMAN-6758 error.</p> <p>In a Data Guard environment, the primary and standby hosts may have different channel configurations for communicating with their associated SBT backup and disk devices. If both the primary and standby databases are known to the recovery catalog, then the configuration settings for both databases are recorded in the recovery catalog. Because the two databases have the same DB_NAME, the records in the recovery catalog can only be distinguished with the DB_UNIQUE_NAME initialization parameter.</p> <p><b>Note:</b> Using <code>RESTORE SPFILE</code> when the DB_NAME is not unique in the recovery catalog produces an RMAN-6758 error.</p> <p><b>See Also:</b> <i>Oracle Data Guard Concepts and Administration</i> for a detailed procedure for restoring the server parameter file in a Data Guard environment</p>
TO 'filename'	<p>Restores the standby control file to the specified file name. <a href="#">Table 3-9</a> explains the RMAN behavior when restoring the control file with the TO clause.</p>

Syntax Element	Description
STANDBY CONTROLFILE	<p>Restores a control file for a standby database. RMAN can transparently restore a normal control file backup and make it usable for a standby database.</p> <p>RMAN restores either a normal or standby control file as appropriate, depending on the most recent database role known to the recovery catalog (<code>RC_SITE.DATABASE_ROLE</code>) for the target database. The purpose of this option to override the default setting in cases where the most recent database role is out-of-date. Assume that you perform a switchover from primary database <code>dgny</code> to standby database <code>dgsf</code>, so that <code>dgsf</code> is the new primary database. Later, you make <code>dgny</code> a standby database for <code>dgsf</code>. You want to restore a control file on <code>dgny</code>, but the recovery catalog was not resynchronized and still shows <code>dgny</code> as a primary database. In this case, you can specify <code>STANDBY CONTROLFILE</code> to override the default RMAN behavior and restore a standby control file.</p> <p>If you restore the control file of a database whose <code>DB_UNIQUE_NAME</code> is known to the recovery catalog, then RMAN updates all file names in the control file to file names known to the recovery catalog. Any file names explicitly renamed with <code>ALTER DATABASE RENAME FILE</code> take precedence over the file names in the recovery catalog.</p> <p><b>See Also:</b> <a href="#">Table 3-9</a> for restrictions and usage notes</p> <p><b>Note:</b> You must always run the <code>RECOVER</code> command after mounting a restored control file, and must also always open the database with the <code>RESETLOGS</code> option.</p>
TABLESPACE <i>tablespace_name</i>	<p>Restores all data files in the specified tablespaces (see <a href="#">Example 3-25</a>).</p> <p>RMAN translates the tablespace name internally into a list of data files. If you rename a tablespace (for example, from <code>users</code> to <code>customers</code>), then so long as an additional tablespace with the old name (<code>users</code>) has not been created, you can use either the old name (<code>users</code>) or the new name (<code>customers</code>) for the tablespace. RMAN detects that the tablespace has changed its name and updates the recovery catalog on the next resynchronization.</p> <p><b>Note:</b> RMAN can back up and restore dictionary-managed temporary tablespaces, but it cannot back up locally managed temporary tablespaces. However, RMAN automatically re-creates locally managed temporary tablespaces after restoring the database.</p>

### *restoreSpecOperand*

This subclause specifies options for the `restoreObject` clause. These parameters override the parameters with the same name at the `RESTORE` command level.

Syntax Element	Description
CHANNEL <i>channel_id</i>	Specifies the case-sensitive name of a channel to use for this restore operation. If you do not specify a channel, then <code>RESTORE</code> uses any available channel allocated with the correct device type.



Syntax Element	Description
FROM AUTOBACKUP	Restores a control file autobackup (see <a href="#">Example 3-28</a> ). This option is only valid on the RESTORE CONTROLFILE and RESTORE SPFILE commands. When restoring either type of file in NOCATALOG mode, the FROM AUTOBACKUP clause is required. RMAN begins the search on the current day or on the day specified with the SET UNTIL. On the first day searched, the search begins with sequence number 256 (or the sequence number specified by MAXSEQ, if provided) and counts back to sequence 0. If no autobackup is found in the current or SET UNTIL day, then RMAN checks preceding days, starting with sequence 256 and counting back to 0. The search continues up to MAXDAYS days (default of 7, maximum of 366) before the current or SET UNTIL day. If no autobackup is found within MAXDAYS days, then RMAN signals an error and the command stops. <b>See Also:</b> <a href="#">Table 3-9</a> for restrictions and usage notes.
<a href="#">autoBackupOptList</a>	Specifies parameters that control the search for a control file autobackup.
'media_handle'	Specifies the name of the control file copy or backup piece containing a control file. The media_handle can be any backup piece that contains a backup of a control file: the control file backup does not need to be an autobackup. <b>See Also:</b> <a href="#">Table 3-9</a> for restrictions and usage notes.
FROM SERVICE service_name	Restores data files or control files using backups transferred, over the network, from the remote database. service_name specifies the service name of the remote database.
FROM TAG tag_name	Overrides the default selection of the most recent backups or file copy available. The tag restricts the automatic selection to backup sets or file copies created with the specified tag. If multiple backup sets or copies have a matching tag, then RMAN selects the most recent one. Tag names are not case sensitive. <b>See Also:</b> <a href="#">BACKUP</a> for a description of how a tag can be applied to an individual copy of a duplexed backup set, and for a description of the default file name format for tags.

### **autoBackupOptList**

This subclause specifies parameters that control the search for a control file autobackup.

Syntax Element	Description
DB_NAME database_name	Provides a DB_NAME to be used in searching for control file autobackups. See <a href="#">Table 3-10</a> to determine when to set this parameter. The default value of the DB_UNIQUE_NAME initialization parameter is the DB_NAME initialization parameter setting. If no DB_UNIQUE_NAME initialization parameter is set for a target database, then use either RESTORE ... DB_NAME or RESTORE ... DB_UNIQUE_NAME. If the DB_UNIQUE_NAME initialization parameter setting for a target database is different from DB_NAME, then use RESTORE ... DB_UNIQUE_NAME.
MAXDAYS integer	Limits the search for a control file autobackup to within the specified number of days earlier.
MAXSEQ integer	Specifies the highest sequence number for the control file autobackup search.
RECOVERY AREA 'pathname'	Specifies a path to the fast recovery area to search for autobackups. RECOVERY AREA and DB_RECOVERY_FILE_DEST are synonyms. See <a href="#">Table 3-10</a> to determine when to set this parameter.

Syntax Element	Description
DB_RECOVERY_FILE_DEST 'pathname'	RECOVERY AREA and DB_RECOVERY_FILE_DEST are synonyms.
DB_NAME database_name	Provides a DB_NAME to be used in searching for control file autobackups. See <a href="#">Table 3-10</a> to determine when to set this parameter. The default value of the DB_UNIQUE_NAME initialization parameter is the DB_NAME initialization parameter setting. If no DB_UNIQUE_NAME initialization parameter is set for a target database, then use either RESTORE ... DB_NAME or RESTORE ... DB_UNIQUE_NAME. If the DB_UNIQUE_NAME initialization parameter setting for a target database is different from DB_NAME, then use RESTORE ... DB_UNIQUE_NAME.
DB_UNIQUE_NAME db_unique_name	Specifies the DB_UNIQUE_NAME of the database in the specified fast recovery area that is the target of the restore operation. The default value of the DB_UNIQUE_NAME initialization parameter is the DB_NAME initialization parameter setting. If no DB_UNIQUE_NAME initialization parameter is set for a target database, then use either RESTORE ... DB_NAME or RESTORE ... DB_UNIQUE_NAME. If the DB_UNIQUE_NAME initialization parameter setting for a target database is different from DB_NAME, then use RESTORE ... DB_UNIQUE_NAME.

## Examples

### Example 3-25 Restoring a Tablespace

This example takes a tablespace offline, restores it, then performs media recovery.

```
ALTER TABLESPACE users OFFLINE IMMEDIATE;
RESTORE TABLESPACE users;
RECOVER TABLESPACE users;
ALTER TABLESPACE users ONLINE;
```

### Example 3-26 Setting a New Name for a Restored Data File

Assume that /disk1, which contains data file 9, suffers a media failure. This example specifies a new name for the data file, restores it, updates the control file to use the new name, recovers it, and then brings it online:

```
RUN
{
  ALTER DATABASE DATAFILE 9 OFFLINE;
  SET NEWNAME FOR DATAFILE 9 TO '/disk2/users01.dbf';
  RESTORE DATAFILE 9;
  SWITCH DATAFILE ALL;
  RECOVER DATAFILE 9;
  ALTER DATABASE DATAFILE 9 ONLINE;
}
```

### Example 3-27 Restoring the Control File When Using a Recovery Catalog

Assume that you want to restore the control file backup with the tag monday\_cf\_backup. You start the RMAN client, connect to the target and recovery catalog databases, and run the following commands:

```
RUN
{ # SET DBID is not necessary when RMAN is connected to a recovery catalog
  STARTUP FORCE NOMOUNT;
```

```

RESTORE CONTROLFILE FROM TAG 'monday_cf_backup';
ALTER DATABASE MOUNT;
RESTORE DATABASE;
RECOVER DATABASE;
}
ALTER DATABASE OPEN RESETLOGS; # required after recovery with backup control file

```

RMAN restores the control file to its default location and replicates it automatically to all `CONTROL_FILES` locations. RMAN mounts the control file and restores and recovers the database. RMAN automatically updates the control file to reflect the structure of the restored database based on the metadata in the recovery catalog.

### Example 3-28 Recovering the Database with a Control File Autobackup

Assume that the control file and some data files are lost and must be restored from tape. Because RMAN does not use a recovery catalog in this scenario, the `SET DBID` command is necessary to identify the control file to be restored. The example restores the control file from tape, mounts the database, and then restores and recovers the database.

```

CONNECT TARGET /
STARTUP FORCE NOMOUNT;
SET DBID 36508508; # required when restoring control file in NOCATALOG mode
RUN
{
  ALLOCATE CHANNEL c1 DEVICE TYPE sbt;
  RESTORE CONTROLFILE FROM AUTOBACKUP;
  ALTER DATABASE MOUNT;
  RESTORE DATABASE;
  RECOVER DATABASE;
}
ALTER DATABASE OPEN RESETLOGS;

```

### Example 3-29 Restoring a Control File Autobackup to a Nondefault Location

This example is a variation on [Example 3-28](#). In this scenario, the control file autobackup is located on disk in a nondefault location. RMAN starts searching for backups with a sequence number of 20, and searches backward for 5 months:

```

CONNECT TARGET /
STARTUP FORCE NOMOUNT
SET DBID 36508508; # required when restoring control file in NOCATALOG mode
RUN
{
  SET CONTROLFILE AUTOBACKUP FORMAT FOR DEVICE TYPE DISK
  TO '/disk1/prod_cf_auto_%F';
  RESTORE CONTROLFILE TO '/tmp/cf_auto.dbf' FROM AUTOBACKUP
  MAXSEQ 20 MAXDAYS 150;
  ALTER DATABASE MOUNT;
  RESTORE DATABASE;
  RECOVER DATABASE;
}
ALTER DATABASE OPEN RESETLOGS;

```

### Example 3-30 Restoring Control File Autobackups Stored on Tape or Oracle Cloud

Database backups are created on disk according to a backup schedule. Control file autobackups are enabled, but a recovery catalog is not used. Subsequently, these backup sets are backed up to Oracle Cloud using the `BACKUP BACKUPSET ALL`

command. This example restores a control file using the autobackup that was created on Oracle Cloud. RMAN scans both disk and Oracle Cloud backups and then retrieves the latest control file autobackup. You must configure one disk channel and one SBT channel, for Oracle Cloud.

```
RUN
{
SET DBID 1928835918;
ALLOCATE CHANNEL disk1 DEVICE TYPE DISK;
ALLOCATE CHANNEL sbt1 DEVICE TYPE 'SBT_TAPE' PARMS 'SBT_LIBRARY=/disk1/oss/
libopc.so ENV=(OPC_PFILE=/disk1/oss/opc_sbt.ora)';
RESTORE CONTROLFILE FROM AUTOBACKUP;
}
```

### Example 3-31 Restoring a Server Parameter File Autobackup to the Current Location

The following series of commands restores the current server parameter file in NOCATALOG mode and then starts the instance with the restored server parameter file.

```
CONNECT TARGET /
SET DBID 1620189241; # set dbid to dbid of target database
STARTUP FORCE NOMOUNT; # start instance with dummy SPFILE
RUN
{
  ALLOCATE CHANNEL c1 DEVICE TYPE sbt;
  RESTORE SPFILE FROM AUTOBACKUP; # FROM AUTOBACKUP needed in NOCATALOG mode
  STARTUP FORCE; # startup with restored SPFILE
}
```

### Example 3-32 Previewing Backups

This example shows the results of a RESTORE ... PREVIEW command, which identifies the backup sets RMAN selects for use in restoring archived redo log files.

```
RMAN> RESTORE ARCHIVELOG ALL DEVICE TYPE sbt PREVIEW;
```

```
Starting restore at 01-MAR-13
released channel: ORA_SBT_TAPE_1
allocated channel: ORA_SBT_TAPE_1
channel ORA_SBT_TAPE_1: SID=85 device type=SBT_TAPE
channel ORA_SBT_TAPE_1: Oracle Secure Backup
```

```
List of Backup Sets
```

```
=====
```

BS Key	Size	Device Type	Elapsed Time	Completion Time
53	1.25M	SBT_TAPE	00:00:18	01-MAR-13
BP Key: 53 Status: AVAILABLE Compressed: NO Tag: TAG20130301T150155				
Handle: 2aibhej3_1_1 Media: RMAN-DEFAULT-000001				

```
List of Archived Logs in backup set 53
```

Thrd	Seq	Low SCN	Low Time	Next SCN	Next Time
1	8	526376	01-MAR-13 527059	527059	01-MAR-13
1	9	527059	01-MAR-13 527074	527074	01-MAR-13
1	10	527074	01-MAR-13 527091	527091	01-MAR-13
1	11	527091	01-MAR-13 527568	527568	01-MAR-13
1	12	527568	01-MAR-13 527598	527598	01-MAR-13

validation succeeded for backup piece  
Finished restore at 01-MAR-13

### Example 3-33 Recalling Offsite Backups from Offsite Storage

When used with a media manager that reports information about offsite storage of backups and supports recalling offsite backups, RESTORE ... PREVIEW RECALL requests that any media needed to restore archived redo log files from backup be recalled from offsite storage.

```
RMAN> RESTORE ARCHIVELOG ALL PREVIEW RECALL;
```

```
Starting restore at 10-JUN-13
using channel ORA_DISK_1
using channel ORA_SBT_TAPE_1
```

List of Backup Sets

=====

BS Key	Size	Device Type	Elapsed Time	Completion Time
31	12.75M	SBT_TAPE	00:00:02	10-JUN-13
BP Key: 33 Status: AVAILABLE Compressed: NO Tag: TAG20130610T152755				
Handle: 15gmknbs Media: /v1,15gmknbs				

List of Archived Logs in backup set 31

Thrd	Seq	Low SCN	Low Time	Next SCN	Next Time
1	1	221154	06-JUN-13	222548	06-JUN-13
1	2	222548	06-JUN-13	222554	06-JUN-13
1	3	222554	06-JUN-13	222591	06-JUN-13
1	4	222591	06-JUN-13	246629	07-JUN-13
1	5	246629	07-JUN-13	262451	10-JUN-13

BS Key	Size	Device Type	Elapsed Time	Completion Time
32	256.00K	SBT_TAPE	00:00:01	10-JUN-13
BP Key: 34 Status: AVAILABLE Compressed: NO Tag: TAG20130610T153105				
Handle: 17gmknhp_1_1 Media: /v1,17gmknhp_1_1				

List of Archived Logs in backup set 32

Thrd	Seq	Low SCN	Low Time	Next SCN	Next Time
1	6	262451	10-JUN-13	262547	10-JUN-13
1	7	262547	10-JUN-13	262565	10-JUN-13

Initiated recall for the following list of offsite backup files

=====

```
Handle: 15gmknbs Media: /v1,15gmknbs
Finished restore at 10-JUN-13
```

### Example 3-34 Validating the Restore of a Backup

The following example illustrates using RESTORE ... VALIDATE to confirm that backups required to restore the database are present on disk or tape, readable, and not corrupted:

```
RMAN> RESTORE DATABASE VALIDATE;
```

```
Starting restore at 01-MAR-13
```

```

using channel ORA_DISK_1
allocated channel: ORA_SBT_TAPE_1
channel ORA_SBT_TAPE_1: SID=85 device type=SBT_TAPE
channel ORA_SBT_TAPE_1: Oracle Secure Backup

channel ORA_DISK_1: starting validation of datafile backup set
channel ORA_DISK_1: reading from backup piece /disk2/PROD/backupset/2013_03_01/
ol_mf_nnndf_TAG20130301T161038_2ygtvzg0_.bkp
channel ORA_DISK_1: piece handle=/disk2/PROD/backupset/2013_03_01/
ol_mf_nnndf_TAG20130301T161038_2ygtvzg0_.bkp tag=TAG20130301T161038
channel ORA_DISK_1: restored backup piece 1
channel ORA_DISK_1: validation complete, elapsed time: 00:00:16
Finished restore at 01-MAR-13

```

### Example 3-35 Restoring Data Files on the Primary Database Using the Standby

This example restores the data file `users.dbf` that was lost on the primary database by restoring it, over the network, from the standby database:

```

RESTORE DATAFILE '/oradata/files/users.dbf'
        FROM SERVICE standby_tns
        SECTION SIZE 200M
        USING COMPRESSED BACKUPSET;

```

The service name of the remote database that contains the data file to be restored is `standby_tns`. The `SECTION SIZE` clause indicates that the data file is restored using multisection backup sets. The `USING COMPRESSED BACKUPSET` clause specifies that the backup sets are compressed using the default compression algorithm that is configured for RMAN.

### Example 3-36 Restoring a Database from a Cross-Platform Database Backup

This example restores the database using a cross-platform backup that was created in [Example 2-34](#). This backup was created on a Microsoft Windows IA (32-bit) platform and is being restored on Linux x86 64-bit. The backup set containing the database is stored in `/tmp/xplat_restores/full_db.bck`. The restored data files are stored in `/oradata/datafiles` using unique file names that begin with `df_`

```

RESTORE
        FROM PLATFORM 'Microsoft Windows IA (32-bit)'
        ALL FOREIGN DATAFILES
        FORMAT '/oradata/datafiles/df_%U'
        FROM BACKUPSET '/tmp/xplat_restores/full_db.bck';

```

### Example 3-37 Restoring a Tablespace from a Cross-Platform Tablespace Backup

This example restores the tablespace `example` from the cross-platform backup created in [Example 2-35](#). The backup set containing the tablespace to be restored is stored in `/tmp/xplat_restores/example_readonly.bck`. The restored data files use unique names that begin with `example_readonly_`. The metadata required to plug this tablespace into the target database is stored in the backup set `/tmp/xplat_restores/example_dmp.bck`.

```

RESTORE
        FOREIGN TABLESPACE example
        FORMAT '/tmp/xplat_restores/example_readonly_%U %n'
        FROM BACKUPSET '/tmp/xplat_restores/example_readonly.bck' DUMP FILE
        DATAPUMP DESTINATION '/tmp/datapump'
        FROM BACKUPSET '/tmp/xplat_restores/example_dmp.bck';

```

 **See Also:**

*Oracle Database Backup and Recovery User's Guide* for an example of backing up and restoring multiple tablespaces

### Example 3-38 Restoring a Tablespace Using a Cross-Platform Backup Consisting of Multiple Backup Sets

This example restores the tablespace `example` from a cross-platform backup consisting of multiple backup sets that was created in [Example 2-36](#). You must use a separate `BACKUPSET` clause for each backup set. The backup sets must be listed in the order in which they were created, starting with the first backup set.

```
RESTORE
  BACKUPSET '/tmp/xplat_restores/db_multiple_59nkcln6_1_1'
  BACKUPSET '/tmp/xplat_restores/db_multiple_5ankcln7_1_1'
  BACKUPSET '/tmp/xplat_restores/db_multiple_5bnkcln8_1_1'
  BACKUPSET '/tmp/xplat_restores/db_multiple_5cnkcln9_1_1'
  DUMP FILE
    FROM BACKUPSET '/tmp/xplat_restores/db_multiple.dmp';
```

### Example 3-39 Restoring a Tablespace Using a Cross-Platform Consistent Backup that Contains Multiple Backup Pieces

This example restores the tablespace `example` from a cross-platform backup consisting of multiple backup pieces that was created in [Example 2-37](#). The export dump file containing the metadata of the tablespace is stored in `/tmp/xplat_restores/example_multi-piece_dmp.bck`. The `FROM BACKUPSET` clause contains a comma-separated list of all the backup pieces. List the backup pieces in the same order in which they were created.

```
RESTORE
  FOREIGN TABLESPACE sales
  FORMAT '/tmp/xplat_restores/datafiles/example_mult_%u'
  FROM BACKUPSET
    '/tmp/xplat_restores/example_multi-piece_0lnjnujs_1_1',
    '/tmp/xplat_restores/example_multi-piece_0lnjnujs_2_1',
    '/tmp/xplat_restores/example_multi-piece_0lnjnujs_3_1'
  DUMP FILE
    FROM BACKUPSET '/tmp/xplat_restores/example_multi-piece_dmp.bck';
```

### Example 3-40 Restoring a Cross-Platform Inconsistent Tablespace Backup

This example restores the tablespace `example` from the cross-platform inconsistent backup created in [Example 2-38](#). The restored data files are stored using unique names that begin with `inconsist_`. Because the tablespace was not read-only when the backup was created, you cannot directly plug it into the target database. You must apply an incremental backup of the tablespace taken when the tablespace is read-only to the recovered foreign data files.

```
RESTORE
  FOREIGN TABLESPACE example
  FORMAT '/tmp/xplat_restores/datafiles/inconsist_%u'
  FROM BACKUPSET '/tmp/xplat_backups/example_inconsist.bck';
```

**Example 3-41 Restoring a PDB into a New CDB Using Cross-platform Backups of the PDB**

This example restores a cross-platform backup of the pluggable database (PDB) `pdb3` on the destination CDB. The destination CDB and the source CDB are on different platforms, but use the same endian format.

The destination CDB is open in read-write mode. The backup set contained the cross-platform backup of the source PDB is stored in `/u02/backups/backup_full_pdb3.bck`. The metadata required to plug the source PDB into the destination CDB is stored in `/u02/backups/metadata_pdb3.xml`. The `FILE_NAME_CONVERT` clause specifies how file names on the source CDB must be renamed in the destination CDB.

```
RESTORE FROM PLATFORM 'Linux x86 64-bit'
USING '/u02/backups/metadata_pdb3.xml'
FILE_NAME_CONVERT = ('/u01/oradata', '/u02/oradata/cdb')
FOREIGN PLUGGABLE DATABASE pdb3 FORMAT '/u02/oradata/cdb/pdb3_%U'
FROM BACKUPSET '/u02/backups/backup_full_pdb3.bck';
```

**Example 3-42 Moving an On-premises Database to Oracle Cloud with Encryption**

This example moves an on-premises Oracle Database to Oracle Cloud by restoring database backups. The on-premises database does not use encryption and the database backups are also not encrypted. However, the database on Oracle Cloud must use encryption. Therefore, to maintain consistency and security, the backups of the unencrypted database must be restored on Oracle Cloud using encryption. You can achieve this by using the `AS ENCRYPTED` clause with the `RESTORE` command. The Oracle keystore must be open before the `RESTORE...AS ENCRYPTED` command is run.

The `COMPATIBLE` parameter for the on-premises database is set to 12.2 and the backups are created with `COMPATIBLE` set to 11.2 or higher. The following commands restore the unencrypted backups to create a database on Oracle Cloud with encryption:

```
SELECT ts#, encryptionalg, encryptedts, key_version, status FROM
v$encrypted_tablespaces;
STARTUP FORCE MOUNT;
RESTORE DATABASE AS ENCRYPTED;
RECOVER DATABASE;
ALTER DATABASE OPEN;
```

**Example 3-43 Moving a Database from Oracle Cloud to an On-premises Environment**

This example moves a database from Oracle Cloud, which uses encryption, to an on-premises Oracle Database. Because encryption is not mandatory for on-premises databases, you decide to restore the encrypted backups from Oracle Cloud without using encryption. Use the `AS DECRYPTED` clause of the `RESTORE` command to perform this restore operation.

The `COMPATIBLE` parameter for the on-premises database is set to 12.2. Backups were created with `COMPATIBLE` set to 12.2. The following commands restore the encrypted backups from Oracle Cloud to an on-premises database and without using encryption:

```
SELECT ts#, encryptionalg, encryptedts, key_version, status FROM
v$encrypted_tablespaces;
```



```
STARTUP FORCE MOUNT;  
RESTORE DATABASE AS DECRYPTED  
RECOVER DATABASE;  
ALTER DATABASE OPEN;
```

## 3.9 RESYNC CATALOG

### Purpose

Use the `RESYNC CATALOG` command to perform a full resynchronization of metadata in a recovery catalog schema with metadata in a target database control file. You can also use the `FROM CONTROLFILECOPY` clause to resynchronize the current control file with the RMAN metadata in a control file copy.

Typically, you run `RESYNC CATALOG` in the following situations:

- The recovery catalog was unavailable when you executed RMAN commands that automatically perform a resynchronization.
- The target database is running in `ARCHIVELOG` mode, because the recovery catalog is *not* updated automatically when an online redo log switch occurs or when a redo log is archived.
- You made changes to the physical structure of the target database such as adding or dropping a tablespace. As with log archiving, the recovery catalog is *not* updated automatically when the physical schema changes.
- RMAN is connected as `TARGET` to a standby database. You want to update the recovery catalog with metadata about RMAN operations performed on this database.
- RMAN is connected as `TARGET` to a standby database. You want to update the recovery catalog with metadata about a physical change on the primary database (see [Example 3-46](#)).

### Prerequisites

RMAN must be connected as `TARGET` to a mounted or open database and connected as `CATALOG` to a recovery catalog database. When running `RESYNC CATALOG` with multiple databases, a network connection is required for each target database.

### Usage Notes

Resynchronizations are full or partial. If full, and if the target database has mounted the current control file (but not a newly created control file or a control file that is less current than a control file that was used previously), then RMAN updates all changed records for the physical schema: data files, tablespaces, redo threads, and online redo logs. If the database is open, then RMAN also obtains data about rollback segments. If the resynchronization is partial, then RMAN does not resynchronize metadata about the physical schema or rollback segments.

If the target control file is mounted and the catalog database is available at command execution, then RMAN automatically resynchronizes the recovery catalog as needed when you use RMAN commands. RMAN performs a full resynchronization after structural changes to database (adding or dropping database files, creating new incarnation, and so on) or after changes to the RMAN persistent configuration.

Starting with Oracle Database 11g, a single recovery catalog schema can keep track of database file names for all databases in a Data Guard environment. This catalog schema also keeps track of where the online redo logs, standby redo logs, temp files, archived redo log files, backup sets, and image copies are created for all databases. If RMAN is connected as `TARGET` to a standby database, then RMAN implicitly executes a full resynchronization if the standby control file contains information about a physical schema change on the primary database.



**See Also:**

*Oracle Database Backup and Recovery User's Guide* for more information about catalog resynchronization

**Syntax**

**resync::=**

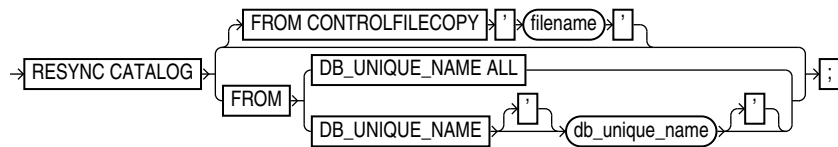

**Semantics**

Syntax Element	Description
RESYNC CATALOG	<p>Updates the recovery catalog with RMAN metadata in the current control file of the target database (default).</p> <p>RMAN creates a snapshot control file to obtain a read-consistent view of the control file, then updates the recovery catalog with any new information from the snapshot. The <code>RESYNC CATALOG</code> command updates the following classes or records:</p> <ul style="list-style-type: none"> <li>• Log history records, which are created when a log switch occurs. Log history records describe an online log switch, not a log archival.</li> <li>• Archived redo log records, which are associated with archived redo log files created by archiving an online redo log, copying an existing archived log, or restoring backups of archived redo log files.</li> <li>• Backup records, which are records of backup sets, backup pieces, proxy copies, and image copies.</li> <li>• Physical schema records, which are associated with data files and tablespaces. If the target database is open, then rollback segment information is also updated.</li> </ul>

Syntax Element	Description
<pre>FROM CONTROLFILECOPY 'filename'</pre>	<p>Updates the current control file and recovery catalog with RMAN metadata from a control file copy (see <a href="#">Example 3-45</a>). Use <i>filename</i> to specify the name of the control file copy to use for resynchronization.</p> <p>The primary use for <code>FROM CONTROLFILECOPY</code> occurs when you re-create the control file, which causes you to lose RMAN records stored in the control file. You can then resynchronize the newly created control file with an old copy. Physical schema information is not updated when you use this option.</p> <p><b>Note:</b> The control file copy can either be in the current database incarnation, or created in a prior incarnation (that is, before the most recent <code>OPEN RESETLOGS</code>).</p>
<pre>FROM DB_UNIQUE_NAME {ALL   db_unique_name}</pre>	<p>Resynchronizes the recovery catalog with control file metadata in the specified database or databases (see <a href="#">Example 3-47</a>).</p> <p>When the <code>FROM DB_UNIQUE_NAME ALL</code> option is used to perform resynchronization, you must connect to the target database as the <code>SYS</code> user and using password file authentication.</p> <p>You can specify a single database with <i>db_unique_name</i> or use <code>ALL</code> for all databases in the recovery catalog that share the DBID of the target database. If you specify <code>ALL</code>, then RMAN resynchronizes all databases in the Data Guard environment that are known to the recovery catalog.</p> <p><b>Note:</b> You must have previously used <code>CONFIGURE DB_UNIQUE_NAME ... CONNECT IDENTIFIER</code> to specify a net service name to be used for an Oracle Net connection to the database specified in <code>FROM DB_UNIQUE_NAME</code>.</p> <p>When you run <code>RESYNC FROM DB_UNIQUE_NAME</code> for a specified database, RMAN performs both a normal resynchronization and a reverse resynchronization. In a normal resynchronization, RMAN updates the recovery catalog with metadata from the control file. In a reverse resynchronization, RMAN updates the persistent configurations in the control file if they do not match the information in the recovery catalog for the specified database.</p> <p>For a sample use case, suppose that you recently connected RMAN as <code>TARGET</code> to the primary database and ran <code>CONFIGURE</code> to create an RMAN configuration for standby database <code>standby_new</code>. However, you have not yet connected RMAN as <code>TARGET</code> to <code>standby_new</code>. In this case, you can run <code>RESYNC CATALOG FROM DB_UNIQUE_NAME standby_new</code>. When you later connect RMAN to <code>standby_new</code> as <code>TARGET</code>, RMAN pushes the configuration from the recovery catalog to the mounted control file of <code>standby_new</code>.</p> <p><b>Note:</b> The password file must be identical on all of the remote databases for this feature to work properly. You must manually copy it to all the remote databases in the configuration.</p>

## Examples

### Example 3-44 Resynchronizing the Recovery Catalog in ARCHIVELOG Mode

This example performs a full resynchronization of the target database after archiving all unarchived redo log files.

```

RMAN> CONNECT TARGET "sbu@prod AS SYSBACKUP"
RMAN> CONNECT CATALOG rco@catdb

```

```

recovery catalog database Password: password
connected to recovery catalog database

```

```

RMAN> ALTER SYSTEM ARCHIVE LOG CURRENT;
RMAN> RESYNC CATALOG;

```

**Example 3-45 Resynchronizing the Recovery Catalog from a Control File Copy**

Suppose you want to retrieve some backup information from a control file copy.

Assume that you start the RMAN client and connect to a target database and recovery catalog. The following commands shut down and mount the target database, update the RMAN repository in the current control file with metadata from a backup control file, and then open the database.

```
STARTUP FORCE MOUNT
RESYNC CATALOG FROM CONTROLFILECOPY '/disk1/cfile.dbf';
ALTER DATABASE OPEN;
```

**Example 3-46 Resynchronizing the Recovery Catalog After a Structural Change**

Suppose you have the following:

- A Data Guard environment containing primary database `prod` and standby database `standby3`
- Both the primary and the standby databases are registered with the catalog
- You take a backup of the database and archive logs
- You start SQL\*Plus, connect to database `prod`, and add a data file to tablespace `users` as follows:

```
SQL> ALTER TABLESPACE users ADD DATAFILE '?/oradata/prod/users03.dbf'
      2 SIZE 1M AUTOEXTEND ON
      3 NEXT 10K MAXSIZE 10M;
```

The goal is to update the recovery catalog with metadata about this change. After the change is propagated to `standby3`, you start the RMAN client, connect to `standby3` as `TARGET`, and connect to the recovery catalog.

The next step is to define the connect identifiers for the standby database in your Data Guard environment with the `CONNECT IDENTIFIER` clause of the `CONFIGURE` command:

```
CONFIGURE DB_UNIQUE_NAME standby3 CONNECT IDENTIFIER 'inst2';
```

At this point, you use the `RESYNC CATALOG ... ALL` command to resynchronize the recovery catalog with changes for all the databases in the Data Guard environment. While you can resynchronize the catalog with a specific standby site's information, Oracle recommends you use the `ALL` option to keep the recovery catalog schema current with any database changes that may have occurred within your Data Guard environment:

```
RMAN> RESYNC CATALOG FROM DB_UNIQUE_NAME ALL;
```

The recovery catalog is updated with metadata about the data file added to the `users` tablespace of database `prod`.

**Example 3-47 Resynchronizing the Recovery Catalog with a Standby Database**

Suppose that primary database `prod` and standby database `dgprod3` exist in a Data Guard environment. Your goal is to create an RMAN configuration for `dgprod3`.

You connect RMAN to database `prod` as `TARGET` and then connect to the recovery catalog. You use `CONFIGURE` to update the persistent RMAN configuration for `dgprod3` in the recovery catalog as follows:

```
CONFIGURE DEFAULT DEVICE TYPE TO sbt FOR DB_UNIQUE_NAME dgprod3;
CONFIGURE DB_UNIQUE_NAME dgprod3 CONNECT IDENTIFIER 'inst3';
```

You have not yet performed any backups or other RMAN operations on `dgprod3`, so the control file of `dgprod3` and the recovery catalog metadata for `dgprod3` are not synchronized. In the same RMAN session, you synchronize the `dgprod3` control file with the recovery catalog as follows:

```
RESYNC CATALOG FROM DB_UNIQUE_NAME dgprod3;
```

RMAN updates the default device type to SBT at `dgprod3` and also updates the recovery catalog with the names from the `dgprod3` control file.

## 3.10 REVOKE

### Purpose

Use the `REVOKE` command to revoke recovery catalog privileges previously granted with the `GRANT` command.

### Prerequisites

Execute this command at the RMAN prompt only.

### Usage Notes

Assume that a virtual private catalog user is granted the `REGISTER DATABASE` privilege, which implicitly grants the `CATALOG FOR DATABASE` privilege for any registered database. This user registers multiple databases. If you `REVOKE` the `REGISTER DATABASE` privilege from this user, then this user retains `CATALOG FOR DATABASE` privileges for the registered databases. The `CATALOG` privileges include registering and unregistering the specified databases.

To prevent this user from accessing the metadata for any databases or registering additional databases, execute `REVOKE ALL PRIVILEGES` for this user. To revoke `CATALOG` privileges for a subset of the databases registered by this user, execute `REVOKE CATALOG FOR DATABASE` for each database in the subset.

### Syntax

**revoke::=**

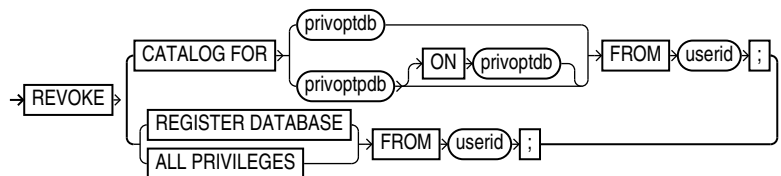

**privoptdb::=**

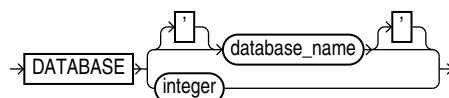

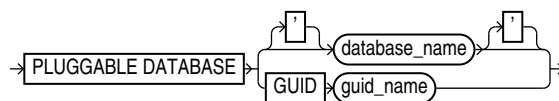
**privoptpdb:-****Semantics**

Syntax Element	Description
CATALOG FOR DATABASE { <i>database_name</i>   <i>integer</i> }	Revokes recovery catalog access for the specified database from the specified user.  You can specify the database by either database name or DBID. If you specify a database name when multiple databases with this name are registered in the recovery catalog, then RMAN returns an error. In this case, specify the database by DBID.
CATALOG FOR PLUGGABLE DATABASE { <i>database_name</i>   GUID <i>guid_name</i> }	Revokes recovery catalog access for the specified pluggable database (PDB) from the specified user.  You can specify the PDB either by the name or GUID of the PDB. If you specify a PDB name when multiple PDBs with this name are registered in the recovery catalog, then RMAN returns an error. In this case, specify the PDB using the GUID.
REGISTER DATABASE	Revokes the ability to for the specified user to register new databases in this recovery catalog (see <a href="#">Example 3-48</a> ).
ALL PRIVILEGES FROM <i>userid</i>	Revokes all CATALOG and REGISTER privileges from the specified user.  Specifies the name of the user from which you are revoking privileges.

**Examples****Example 3-48 Revoking Privileges from a Virtual Private Catalog User**

Assume that you connect RMAN to a base recovery catalog as the recovery catalog owner `rco`. As the base catalog owner, you use the RMAN `GRANT` command as follows to give `bckop2` the ability to register any database in her virtual private catalog, but grant `bckop3` access to only a subset of the databases in the data center:

```
RMAN> CONNECT CATALOG rco@catdb

recovery catalog database Password: password
connected to recovery catalog database

RMAN> GRANT REGISTER DATABASE TO bckop2;
RMAN> GRANT CATALOG FOR DATABASE prod TO bckop3;
RMAN> GRANT CATALOG FOR DATABASE prodb TO bckop3;
RMAN> EXIT;
```

Later, you want to restrict the privileges for user `BCKOP2` so that this user cannot register new databases, so you connect to the base catalog as `rco` and execute a `REVOKE` command. `BCKOP2` retains catalog privileges on the database that this user registered.

```
RMAN> CONNECT CATALOG rco@catdb

recovery catalog database Password: password
connected to recovery catalog database
```

```
RMAN> REVOKE REGISTER DATABASE FROM bckop2;
```

## 3.11 RMAN

### Purpose

Use the `RMAN` command to start RMAN from the operating system command line.

### Prerequisites

You must issue the `RMAN` command and any options at the operating system command line rather than at the RMAN prompt.

RMAN connections to a database are specified and authenticated in the same way as SQL\*Plus connections to a database. The only difference is that RMAN connections to a target or auxiliary database require the `SYSBACKUP` privilege.

#### See Also:

- *Oracle Database Administrator's Guide* to learn about database connection options when using SQL\*Plus
- *Oracle Database Backup and Recovery User's Guide* to learn about using the `SYSBACKUP` administrative privilege

#### Caution:

Good security practice requires that passwords are not entered in plain text on the command line. Enter passwords in RMAN only when requested by an RMAN prompt. See *Oracle Database Security Guide* to learn about password protection.

### Usage Notes

The command name that you enter at the operating system prompt is operating system-dependent. For example, enter `rman` in lowercase on Linux and UNIX systems.

If you start RMAN without specifying either `CATALOG` or `NOCATALOG` on the operating system command line, then the RMAN session is effectively in `NOCATALOG` mode unless you execute a `CONNECT CATALOG` command (see [Example 3-49](#)). If you maintain a recovery catalog, then the best practice is to connect RMAN to the recovery catalog before performing RMAN operations.

### Syntax

```
cmdLine::=
```

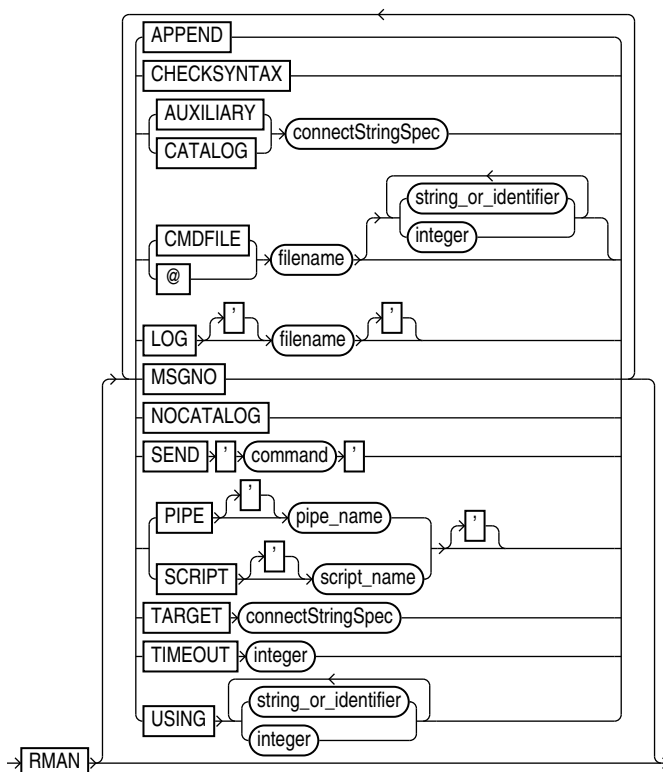

## Semantics

### cmdLine

Syntax Element	Description
APPEND	Causes new output to be appended to the end of the message log file. If you do not specify this parameter, and if a file with the same name as the message log file exists, then RMAN overwrites it.
CHECKSYNTAX	Causes RMAN to start in a mode in which commands entered are checked for syntax errors, but no other processing is performed (see <a href="#">Example 3-52</a> ). If used with a CMDFILE or @ argument, then the RMAN client starts, checks all commands in the file, then exits. If used without specifying a command file, then RMAN prompts the user for input and parses each command until the user exits the RMAN client.  RMAN reports an RMAN-0558 error for each command that is not syntactically correct.
AUXILIARY <a href="#">connectStringSpec</a>	Specifies a connect string to an auxiliary database, for example, AUXILIARY sbu@dupdb.  <b>See Also:</b> <a href="#">connectStringSpec</a>
CATALOG <a href="#">connectStringSpec</a>	Specifies a connect string to the database containing the recovery catalog, for example, CATALOG rco@inst2.  <b>See Also:</b> <a href="#">connectStringSpec</a>



Syntax Element	Description
<code>CMDFILE filename</code>	<p>Parses and compiles all RMAN commands in a file and then sequentially executes each command in the file. RMAN exits if it encounters a syntax error during the parse phase or if it encounters a runtime error during the execution phase. If no errors are found, then RMAN exits after the job completes.</p> <p>If the first character of the file name is alphabetic, then you can omit the quotes around the file name. The contents of the command file are identical to commands entered at the RMAN prompt.</p> <p><b>Note:</b> If you run a command file at the RMAN prompt rather than as an option on the operating system command line, then RMAN does <i>not</i> run the file as a single job. RMAN reads each line sequentially and executes it, only exiting when it reaches the last line of the script.</p>
<code>@filename</code>	Equivalent to <code>CMDFILE</code> .
<code>{string_or_identifier   integer}</code>	Equivalent to options specified after <code>USING</code> syntax.
<code>LOG filename</code>	<p>Specifies the file where RMAN records its output, that is, the commands that were processed and their results. RMAN displays command input at the prompt but does not display command output, which is written to the log file. By default RMAN writes its message log file to standard output.</p> <p>RMAN output is also stored in the <code>V\$RMAN_OUTPUT</code> view, which is a memory-only view for jobs in progress, and in <code>V\$RMAN_STATUS</code>, which is a control file view for completed jobs and jobs in progress.</p> <p>The <code>LOG</code> parameter does not cause RMAN to terminate if the specified file cannot be opened. Instead, RMAN writes to standard output.</p> <p><b>Note:</b> The easiest way to send RMAN output both to a log file and to standard output is to use the Linux <code>tee</code> command or its equivalent. For example:</p> <pre>% rman   tee rman.log</pre>
<code>MSGNO</code>	Causes RMAN to print message numbers, that is, <code>RMAN-xxxx</code> , for the output of all commands. By default, RMAN does not print the <code>RMAN-xxxx</code> prefix.
<code>NOCATALOG</code>	Indicates that you are using RMAN without a recovery catalog.
<code>SEND 'command'</code>	<p>Sends a vendor-specific command string to all allocated channels.</p> <p><b>See Also:</b> Your media management documentation to determine whether this feature is supported, and <a href="#">SEND</a></p>
<code>PIPE pipe_name</code>	<p>Invokes the RMAN pipe interface. RMAN uses two public pipes: one for receiving commands and the other for sending output. The names of the pipes are derived from the value of the <code>PIPE</code> parameter. For example, you can invoke the RMAN pipe interface with the following options: <code>PIPE rpi TARGET /</code>.</p> <p>RMAN opens the following pipes in the target database:</p> <ul style="list-style-type: none"> <li>• <code>ORA\$RMAN_RPI_IN</code>, which RMAN uses to receive user commands</li> <li>• <code>ORA\$RMAN_RPI_OUT</code>, which RMAN uses to send all output</li> </ul> <p>All messages on both the input and output pipes are of type <code>VARCHAR2</code>.</p> <p><b>See Also:</b> <i>Oracle Database Backup and Recovery User's Guide</i> to learn how to pass commands to RMAN through a pipe</p>

Syntax Element	Description
SCRIPT <i>script_name</i>	<p>Specifies the name of a stored script.</p> <p>After connecting to a target database and recovery catalog (which must be specified with the <code>TARGET</code> and <code>CATALOG</code> options), RMAN runs the named stored script from the recovery catalog against the target database. If both a global script and a local stored script exist on the target database with the name <i>script_name</i>, then RMAN runs the local script.</p> <p>The single quotes around the stored script name are required when the script name either begins with a number or is an RMAN reserved word (see "RMAN Reserved Words"). Avoid using such names.</p> <p><b>See Also:</b> <a href="#">CREATE SCRIPT</a> for more details about stored scripts</p>
TARGET <a href="#">connectStringSpec</a>	<p>Specifies a connect string to the target database, for example, <code>TARGET /</code>.</p> <p><b>See Also:</b> <a href="#">connectStringSpec</a></p>
TIMEOUT <i>integer</i>	<p>Causes RMAN to exit automatically if it does not receive input from an input pipe within <i>integer</i> seconds. The <code>PIPE</code> parameter must be specified when using <code>TIMEOUT</code>.</p> <p><b>See Also:</b> <i>Oracle Database Backup and Recovery User's Guide</i> to learn how to pass commands to RMAN through a pipe</p>
USING { <i>string_or_identifier</i>   <i>integer</i> }	<p>Specifies one or more values for use in substitution variables in a command file. As in SQL*Plus, <code>&amp;1</code> indicates where to place the first value, <code>&amp;2</code> indicate where to place the second value, and so on. <a href="#">Example 3-51</a> illustrates how to pass values specified in a <code>USING</code> clause to an RMAN command file.</p> <p>The substitution variable syntax is <code>&amp;integer</code> followed by an optional dot, for example, <code>&amp;1.3</code>. The optional dot is part of the variable and replaced with the value, thus enabling the substitution text to be immediately followed by another integer. For example, if you pass the value <code>mybackup</code> to a command file that contains the substitution variable <code>&amp;1.3</code>, then the result of the substitution is <code>mybackup3</code>.</p> <p><b>See Also:</b> <a href="#">EXECUTE SCRIPT</a> to learn how to specify the <code>USING</code> clause when executing a stored script</p>

## Examples

### Example 3-49 Connecting RMAN to a Target Database in Default NOCATALOG Mode

In this example, you start the RMAN client without specifying database connection options at the operating system prompt. At the RMAN prompt, you run the `CONNECT` command to connect to a target database. Because `CONNECT CATALOG` was not run at the RMAN prompt, RMAN connects in default `NOCATALOG` mode when the first command requiring a repository connection is run, which in this case is the `BACKUP DATABASE` command.

```
% rman
RMAN> CONNECT TARGET /
RMAN> BACKUP DATABASE;
```

### Example 3-50 Connecting RMAN to an Auxiliary Database Instance

This example connects to target database `prod` and recovery catalog database `catdb` with net service names, and connects to an auxiliary database instance with operating system authentication. `sbu` is a user who is granted the `SYSPRIVILEGE` privilege.

```
$ RMAN TARGET "sbu@prod AS SYSBACKUP"
```

Recovery Manager: Release 12.1.0.1.0 - Production on Wed Jan 16 09:29:02 2013

Copyright (c) 1982, 2013, Oracle and/or its affiliates. All rights reserved.

```
target database Password: password
connected to target database: REL12 (DBID=3152825380)
```

```
RMAN> CONNECT CATALOG rco@catdb
```

```
recovery catalog database Password: password
connected to recovery catalog database
```

```
RMAN> CONNECT AUXILIARY /
```

```
connected to auxiliary database: REL12 (DBID=3152825380)
```

### Example 3-51 Specifying Substitution Variables

Suppose that you want to create a Linux shell script that backs up the database. You want to use shell variables so that you can pass arguments to the RMAN backup script at run time. Substitution variables solve this problem. First, you create a command file named `whole_db.cmd` with the following contents:

```
cat > /tmp/whole_db.cmd <<EOF
# name: whole_db.cmd
CONNECT TARGET /
BACKUP TAG &1 COPIES &2 DATABASE FORMAT '/disk2/db_%U';
EXIT;
EOF
```

Next, you write the following Linux shell script, which sets `csh` shell variables `tagname` and `copies`. The shell script starts RMAN, connects to target database `prod1`, and runs `whole_db.cmd`. The `USING` clause passes the values in the variables `tagname` and `copies` to the RMAN command file at execution time.

```
#!/bin/csh
# name: runbackup.sh
# usage: use the tag name and number of copies as arguments
set tagname = $argv[1]
set copies = $argv[2]
rman @'/tmp/whole_db.cmd' USING $tagname $copies LOG /tmp/runbackup.out
# the preceding line is equivalent to:
# rman @'/tmp/whole_db.cmd' $tagname $copies LOG /tmp/runbackup.out
```

Finally, you execute the shell script `runbackup.sh` from a Linux shell as follows to create two backups of the database with the tag `Q106`:

```
% runbackup.sh Q106 2
```

### Example 3-52 Checking the Syntax of a Command File

Suppose that you create command file `backup_db.cmd` as follows:

```
cat > /tmp/backup_db.cmd <<EOF
CONNECT TARGET /
BACKUP DATABASE;
EXIT;
EOF
```

The following example checks the syntax of the contents of command file `backup_db.cmd` (sample output included):

```
% rman CHECKSYNTAX @'/tmp/backup_db.cmd'

Recovery Manager: Release 12.1.0.1.0 - Production on Wed Jan 16 17:51:30 2013

Copyright (c) 1982, 2013, Oracle and/or its affiliates. All rights reserved.

RMAN> CONNECT TARGET *
2> BACKUP DATABASE;
3> EXIT;
The cmdfile has no syntax errors

Recovery Manager complete.
```

### Example 3-53 Running a Stored Script and Appending Output to a Message Log

This example connects to a target database using operating system authentication and then runs stored script `wdbb`. RMAN writes output to message log `/tmp/wdbb.log`.

```
% rman TARGET / SCRIPT wdbb LOG /tmp/wdbb.log
```

### Example 3-54 Invoking the RMAN Pipe Interface

This example invokes the RMAN pipe `newpipe` with a 90 second timeout option.

```
% rman PIPE newpipe TARGET / TIMEOUT 90
```

## 3.12 RUN

### Purpose

Use the `RUN` command to group a series RMAN commands into a block to be executed sequentially. On reading the closing brace of the `RUN` block, RMAN compiles the list of job commands into one or more job steps and then executes the steps immediately.

### Prerequisites

Execute this command only at the RMAN prompt. You must precede the list of job commands with an opening brace (`{`) and terminate it with a closing brace (`}`).

### Usage Notes

You can use `RUN` to create a scope within which a script can override default configurations. For example, you can override configured channels with the [ALLOCATE CHANNEL](#) and [RELEASE CHANNEL](#) commands and other parameters with the [SET](#) command (as shown in [Example 3-55](#)). After executing the commands listed in the `RUN` block, the channels allocated within the `RUN` block are released and settings returned to their values.

As shown in [Example 3-56](#), you must use the [EXECUTE SCRIPT](#) command within a `RUN` block.

### Syntax

***run::=***

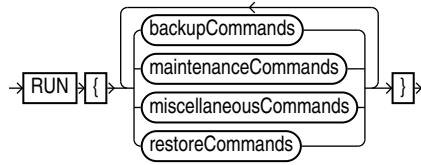

([backupCommands::=](#), [maintenanceCommands::=](#), [miscellaneousCommands::=](#), [restoreCommands::=](#))

***backupCommands::=***



***maintenanceCommands::=***

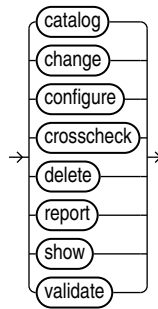

***miscellaneousCommands::=***

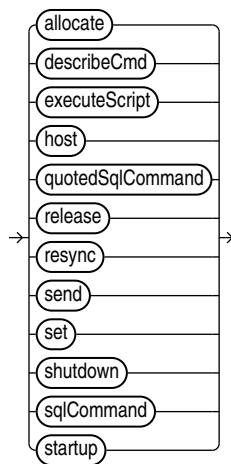

***restoreCommands::=***

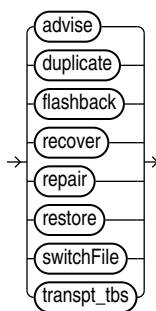

### Semantics

Refer to individual command entries for information about commands that you can run from the RMAN prompt.

### Examples

#### Example 3-55 Overriding Configured Settings

Assume that your configured device configuration is as follows:

```
RMAN> SHOW DEVICE TYPE;
```

```
RMAN configuration parameters for database with db_unique_name PROD1 are:
CONFIGURE DEVICE TYPE DISK PARALLELISM 1 BACKUP TYPE TO BACKUPSET; # default
CONFIGURE DEVICE TYPE SBT_TAPE PARALLELISM 1 BACKUP TYPE TO BACKUPSET; # default
```

You want to make a backup to a nondefault directory. Instead of changing the configuration, you can override it in the job as follows:

```
RUN
{
  ALLOCATE CHANNEL c1 DEVICE TYPE DISK FORMAT "/disk2/%U";
  BACKUP DATABASE PLUS ARCHIVELOG;
}
```

#### Example 3-56 Executing an RMAN Script

Assume that you use the [CREATE SCRIPT](#) command to create a backup script named `backup_db`. This example executes the stored script:

```
RUN { EXECUTE SCRIPT backup_db; }
```

## 3.13 SEND

### Purpose

Use the `SEND` command to send a vendor-specific string to one or more channels supported by a media manager. Refer to your media management documentation to determine which commands are supported.

### Usage Notes

Unless you specify `DEVICE TYPE` or `CHANNEL`, RMAN uses all allocated channels.

On Windows platforms, use `SEND` to pass command strings to the SBT library, instead of using `ENV` settings in the `PARAMS` option during channel allocation. In Oracle Database, operations that run in parallel on Windows use multiple threads within a single process. The environment variables set by one thread are visible to all threads. Thus, parallel operations that depend on environment variables set by a particular thread may not work as expected.

## Syntax

**send::=**

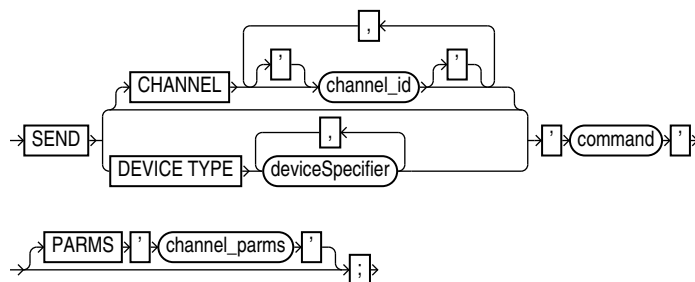

([deviceSpecifier::=](#))

## Semantics

Syntax Element	Description
CHANNEL <i>channel_id</i>	Specifies which channel to use. You must specify a case-sensitive channel ID, which is the name of the channel, after the CHANNEL keyword. The database uses the channel ID to report I/O errors.
DEVICE TYPE <a href="#">deviceSpecifier</a>	Specifies the type of storage device and sends the command to all channels of the specified type. <b>See Also:</b> <a href="#">deviceSpecifier</a>
' <i>command</i> '	Specifies a vendor-specific media management command. <b>See Also:</b> Your media management documentation to determine which commands are supported. You must only send commands supported by the media manager. The contents of the string are not interpreted by the database, but are passed unaltered to the media management subsystem.
PARMS ' <i>channel_parms</i> '	Specifies parameters for the channel communicating with the media manager.

## Example

### Example 3-57 Specifying a Tape Drive in Oracle Secure Backup

This example uses the `SEND` command to specify a tape drive for a backup of the `users` tablespace to Oracle Secure Backup. No equal sign is inserted between the parameter `OB_DEVICE` and the names of the tape drive.

```
RUN
{
  ALLOCATE CHANNEL c1 DEVICE TYPE sbt;
  SEND 'OB_DEVICE stapel';
  BACKUP TABLESPACE users;
}
```

## 3.14 SET

### Purpose

Use the `SET` command to control RMAN behavior within a job or session. Use `CONFIGURE` to configure options that persist across sessions.

### Prerequisites

You can use the `SET` command either at the RMAN prompt or within a `RUN` block. When used at the RMAN prompt, changes made by `SET` persist until you exit the RMAN client (see [setRmanOption](#)). When used inside of a `RUN` block, changes made by `SET` persist until the end of the `RUN` block or the next `SET` command that changes the value of the same attribute (see [setRunOption](#)).

### Syntax

**set::=**

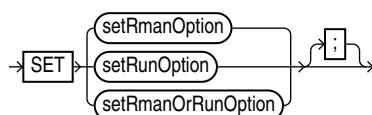

([setRmanOption::=](#), [setRunOption::=](#))

**setRmanOption::=**

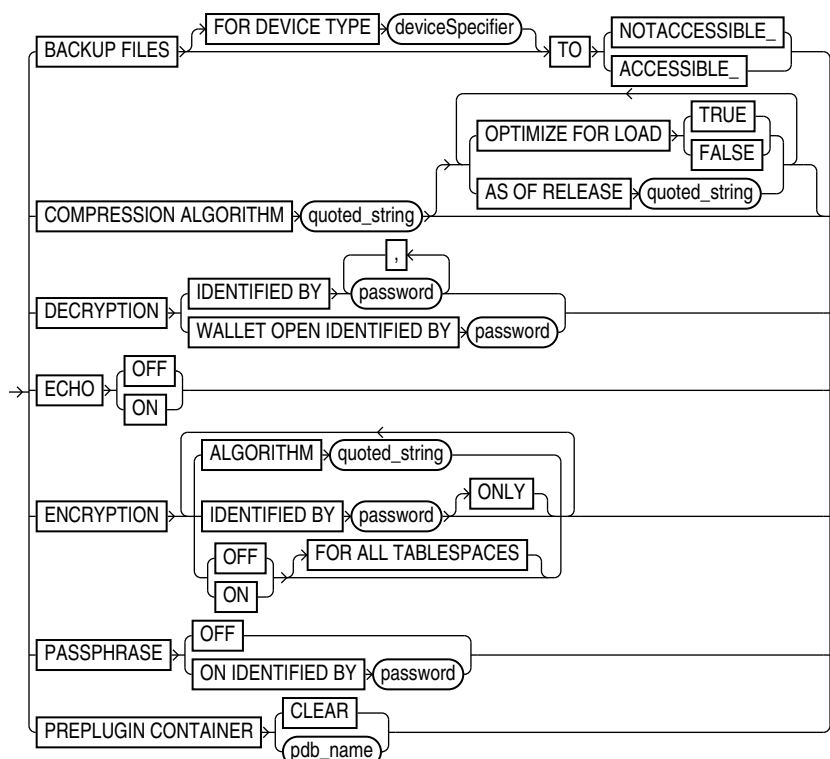

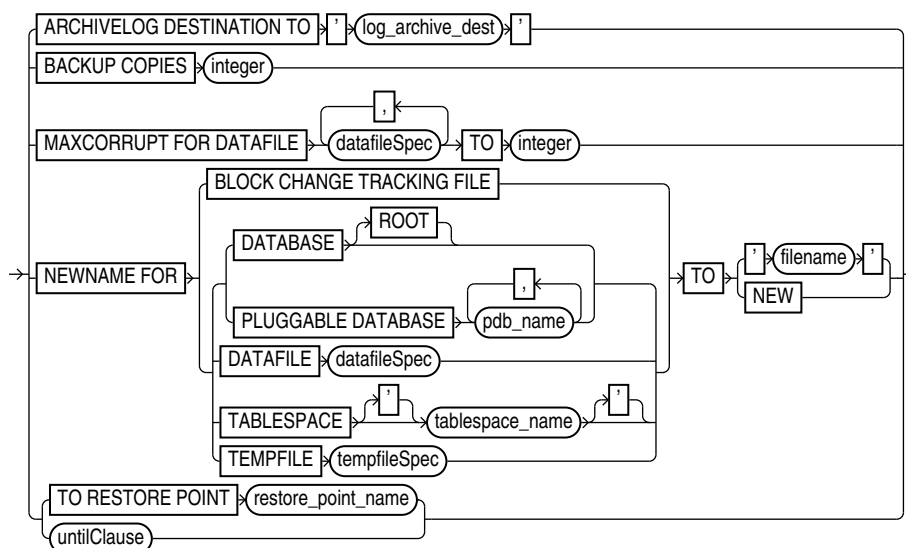

(deviceSpecifier::=, formatSpec::=)

**setRunOption::=**

(deviceSpecifier::=, formatSpec::=, datafileSpec::=, tempfileSpec::=, untilClause::=)

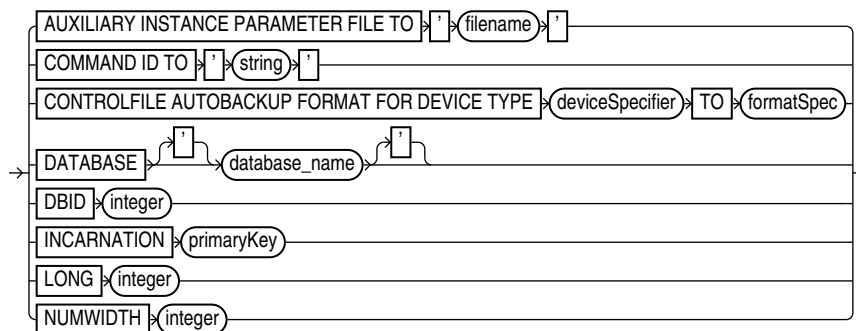
**setRmanOrRunOption::=**

(deviceSpecifier::=, formatSpec::=)

**Semantics****setRmanOption**

This subclause specifies SET options that are usable outside of a RUN block.

Syntax Element	Description
BACKUP FILES	Specifies the visibility of backups in a Data Guard environment. By default, disk backups are visible only to the database with which the backups are associated. The association is determined by the DB_UNIQUE_NAME of the database.

Syntax Element	Description
FOR DEVICE TYPE <i>device_specifier</i>	Specifies the device type for which visibility of backups must be modified.
TO NOTACCESSIBLE	Makes disk backups created on the primary database or standby database available only to the database that created these backups.
TO ACCESSIBLE	Makes backups created on the primary database or standby database accessible to databases whose DB_UNIQUE_NAME is different from that on which the backups were created.
COMPRESSION ALGORITHM ' <i>algorithm_name</i> '	<p>Specifies the compression algorithm for backup sets. This command overrides the current <b>CONFIGURE</b> COMPRESSION ALGORITHM setting for the current RMAN session.</p> <p>You can configure the basic compression level, which does not require the Advanced Compression Option, by specifying <b>BASIC</b> for the <i>algorithm_name</i>.</p> <p>If you have enabled the Advanced Compression Option, you can choose from the following compression levels:</p> <ul style="list-style-type: none"> <li><b>HIGH</b> - Best suited for backups over slower networks where the limiting factor is network speed</li> <li><b>MEDIUM</b> - Recommended for most environments. Good combination of compression ratios and speed</li> <li><b>LOW</b> - Least impact on backup throughput and suited for environments where CPU resources are the limiting factor.</li> </ul> <p><b>Note:</b> The compression ratio generally increases from <b>LOW</b> to <b>HIGH</b>, with a trade-off of potentially consuming more CPU resources.</p> <p>Because the performance of the various compression levels depends on the nature of the data in the database, network configuration, system resources and the type of computer system and its capabilities, universally applicable performance statistics are not available. When deciding which level is best, you must consider how balanced your system is regarding bandwidth into the CPU and the actual speed of the CPU. Oracle recommends that you run tests with the different compression levels on the data in your environment. Choose a compression level based on your environment, network traffic characteristics (workload), and data set. This is the only way to ensure that the backup set compression level can satisfy your organization's performance requirements and any applicable service level agreements.</p> <p><b>Note:</b> <code>V\$RMAN_COMPRESSION_ALGORITHM</code> describes supported algorithms.</p> <p><b>See Also:</b> <i>Oracle Database Reference</i> entry for <code>\$RMAN_COMPRESSION_ALGORITHM</code>.</p>
OPTIMIZE FOR LOAD {TRUE FALSE}	<p>Specifies whether Oracle performs pre-compression block processing when compressed backups have been requested. <b>TRUE</b> is the default and <b>FALSE</b> enables pre-compression processing. The default behavior is not to perform pre-compression block processing. Such processing can consume extra CPU resources, and is not needed for blocks that contain all originally loaded data, and have never been the subject of single-row inserts and deletes. Specifying <b>FALSE</b> uses additional CPU resources to perform pre-compression block processing which consists of internal block cleanups and defragmentation that can result in improved levels of binary compression.</p> <p><b>See Also:</b> <i>Oracle Database Backup and Recovery User's Guide</i> to learn more about this option.</p>
AS OF RELEASE ' <i>version_number</i> '	Specifies the release version. The version number uses the release number format and may use as many as 5 numbers to fully qualify the release. For example, 10.2.0.3.0 and 11.2 are acceptable values. This option ensures compression algorithm stability across future releases.

Syntax Element	Description
<pre>DECRYPTION IDENTIFIED BY password</pre>	<p>Specifies one or more decryption passwords to be used when reading dual-mode or password-encrypted backups.</p> <p>Password-encrypted backups require the correct password to be entered before they can be restored. When RMAN reads an encrypted backup piece, it tries each password in the list until it finds the correct one to decrypt this backup piece. RMAN signals an error if no specified keys work.</p> <p><b>Note:</b> If restoring from a group of backups created with different passwords, then specify all of the required passwords on the <code>SET DECRYPTION</code> command. RMAN automatically uses the correct password with each backup set.</p> <p><b>See Also:</b> "<a href="#">Encryption of Backup Sets</a>"</p>
<pre>DECRYPTION WALLET OPEN IDENTIFIED BY password</pre>	<p>Specifies the password that must be used to open the password-based software keystore. Keystores are used while encrypting backup sets using transparent mode encryption.</p> <p>If the database or tablespace uses Transparent Data Encryption (TDE) and you have a password-based software keystore, then you must use the <code>SET DECRYPTION WALLET OPEN IDENTIFIED BY</code> command to open the keystore before you perform complete recovery, PITR, and database duplication.</p> <p>When restoring backups that were created by using transparent encryption with a password-based software keystore, you must specify the password that is used to open the keystore. When duplicating a database that is configured to use transparent encryption with a password-based software keystore, the password that is required to open the keystore must be provided to the auxiliary instance by using this command.</p> <p>The password specified is valid for the session in which the <code>SET</code> command is run. Therefore, even if the auxiliary instance is restarted during database duplication, the password required to open the keystore is available to the auxiliary instance.</p>
<pre>ECHO {OFF   ON}</pre>	<p>Controls whether RMAN commands appear in the message log. When reading commands from a command file, RMAN automatically echoes them to the message log. When reading commands from standard input, by default RMAN does not echo these commands to the message log. To force RMAN to echo the commands, run the <code>SET ECHO ON</code> command before running your command file. Run <code>SET ECHO OFF</code> to disable echoing to the command log.</p> <p>The command is useful when <code>stdin</code> and <code>stdout</code> have been redirected. For example, in UNIX you can redirect RMAN's input and output in this manner:</p> <pre>% rman TARGET / &lt; in_file &gt; out_file</pre> <p>By including <code>SET ECHO ON</code> in the <code>in_file</code>, you enable the commands contained in <code>in_file</code> to be visible in <code>out_file</code>.</p>
<pre>ENCRYPTION</pre>	<p>Specifies encryption-related options that apply to <a href="#">BACKUP</a> commands that create backup sets for the duration of the RMAN session.</p> <p><b>See Also:</b> "<a href="#">Encryption of Backup Sets</a>"</p>
<pre>ALGORITHM 'algorithm_ name'</pre>	<p>Specifies the algorithm used during this RMAN session. Overrides the configured default encryption algorithm specified by <code>CONFIGURE ALGORITHM</code>. Possible values are listed in <code>V\$RMAN_ENCRYPTION_ALGORITHMS</code>.</p>

Syntax Element	Description
IDENTIFIED BY <i>password</i> [ONLY]	<p>Specifies whether to employ a user-specified password in backup encryption according to the following rules:</p> <ul style="list-style-type: none"> <li>• Omit IDENTIFIED BY <i>password</i> clause to specify transparent-mode encrypted backups.</li> <li>• Use IDENTIFIED BY <i>password</i> ONLY to specify password-mode encrypted backups.</li> <li>• Use IDENTIFIED BY <i>password</i> without ONLY to specify dual-mode encrypted backups.</li> </ul> <p>Create a password that is secure. See <i>Oracle Database Security Guide</i> for more information.</p> <p>If the password is <i>not</i> surrounded by quotes, then it is translated internally into upper case. Thus, the following clauses are all synonyms for IDENTIFIED BY "PASSWORD":</p> <ul style="list-style-type: none"> <li>• IDENTIFIED BY <i>password</i></li> <li>• IDENTIFIED BY <i>Password</i></li> <li>• IDENTIFIED BY <i>pAsSwOrD</i></li> </ul> <p><b>Caution:</b> Keystore-based encryption is more secure than password-based encryption because no passwords are involved. Use password-based encryption only when absolutely necessary because your backups must be transportable.</p> <p><b>See Also:</b> "<a href="#">Encryption of Backup Sets</a>" for details on the different encryption modes</p>
{OFF   ON}	<p>Specifies whether to encrypt backup sets. If ON, then the default is to encrypt backup sets. If OFF, then the default is not to encrypt backup sets.</p> <p>This option overrides settings made with the <a href="#">CONFIGURE ENCRYPTION FOR</a> command. If no data files are configured for encryption, then you must explicitly use ON to encrypt required data files.</p> <p>If FOR ALL TABLESPACES is not specified, then this setting controls encryption of backups for tablespaces where <a href="#">CONFIGURE ENCRYPTION FOR TABLESPACE <i>tablespace_name</i></a> has not been used to control encryption behavior.</p>
FOR ALL TABLESPACES	<p>Controls encryption for all tablespaces, overriding any <a href="#">CONFIGURE ENCRYPTION FOR TABLESPACE <i>tablespace_name</i></a> setting.</p>
PASSPHRASE OFF	<p>Deletes the passphrase that was set during backup or restore operations involving TDE-encrypted tablespaces from the memory.</p> <p>It is recommended that you set the passphrase off after you perform a backup or restore of TDE-encrypted tablespaces.</p>
PASSPHRASE ON IDENTIFIED BY	<p>Specifies the passphrase used to wrap the master key when creating or restoring backups of TDE-encrypted tablespaces.</p>
PREPLUGIN CONTAINER	<p>Sets the container for RMAN operations that use preplugin backups to <i>pdb_name</i>. A CDB may contain preplugin metadata for multiple PDBs. While using preplugin backups, use this command to specify the PDB for which the specified operation must be performed. The operations include listing preplugin backups, changing the status of preplugin backups, cataloging preplugin archived redo log files, restoring preplugin backups, and recovering preplugin backups.</p> <p>Use the CLEAR option to clear the current setting for preplugin container.</p>

### setRunOption

This subclause specifies SET options that are usable within a RUN block.

Syntax Element	Description
ARCHIVELOG DESTINATION TO 'log_archive_dest'	<p>Overrides the LOG_ARCHIVE_DEST_1 initialization parameter in the target database when forming names for restored archived redo log files during subsequent <a href="#">RESTORE</a> and <a href="#">RECOVER</a> commands. RMAN restores the logs to the destination specified in 'log_archive_dest'.</p> <p>You can use this command to stage archived redo log files to different locations while restoring a database. RMAN knows where to find the newly restored archived redo log files; it does not require them to be in the destination specified by LOG_ARCHIVE_DEST_1. For example, if you specify a different destination from the one in the parameter file and restore archived log backups, subsequent restore and recovery operations detect this new location.</p> <p>Use this parameter to restore archived redo log files that are not on disk. RMAN always looks for logs on disk first before restoring them from backups.</p>
BACKUP COPIES <i>integer</i>	<p>Specifies the number of copies of each backup piece that the channels create: 1, 2, 3, or 4 (see <a href="#">Example 3-59</a>).</p> <p>RMAN can duplex backups to either disk or tape but cannot duplex backups to tape and disk simultaneously. When backing up to tape, ensure that the number of copies does not exceed the number of available tape devices. Also, if BACKUP COPIES is greater than 1, then the BACKUP_TAPE_IO_SLAVES initialization parameter must be enabled on the target database.</p> <p>The SET BACKUP COPIES command affects all <a href="#">BACKUP</a> commands in the <a href="#">RUN</a> block issued after SET BACKUP COPIES (but not before) and is in effect until explicitly disabled or changed. The SET BACKUP COPIES command affects only <a href="#">BACKUP</a> commands, but does not apply to the <a href="#">BACKUP AS COPY</a> command.</p> <p>The SET BACKUP COPIES command affects all channels allocated in the session. The order of precedence is as follows, with settings higher on the list overriding settings lower on the list:</p> <ol style="list-style-type: none"> <li>1. <a href="#">BACKUP COPIES</a></li> <li>2. <a href="#">SET BACKUP COPIES</a></li> <li>3. <a href="#">CONFIGURE ... BACKUP COPIES</a></li> </ol> <p>The names of the backup pieces are dependent on the <a href="#">FORMAT</a> clause in the <a href="#">BACKUP</a> command. You can specify up to four <a href="#">FORMAT</a> strings. RMAN uses the second, third, and fourth values only when <a href="#">BACKUP COPIES</a>, <a href="#">SET BACKUP COPIES</a>, or <a href="#">CONFIGURE ... BACKUP COPIES</a> is in effect. When choosing which format to use for each backup piece, RMAN uses the first format value for copy 1, the second format value for copy 2, and so on. If the number of format values exceeds the number of copies, then the extra formats are not used. If the number of format values is less than the number of copies, RMAN reuses the format values, starting with the first one.</p> <p><b>Note:</b> <a href="#">BACKUP COPIES</a> option is not valid when files are created in fast recovery area. Backups to the fast recovery area cannot be duplexed.</p> <p><b>Note:</b> Control file autobackups on disk are a special case and are never duplexed: RMAN always writes one and only copy.</p>

Syntax Element	Description
<pre>MAXCORRUPTFOR DATAFILE datafileSpec TO integer</pre>	<p>Sets a limit on the number of previously undetected block corruptions that the database permits in a specified data file or group of data files. The default limit is zero, meaning that RMAN tolerates no corrupt blocks.</p> <p>The <code>SET MAXCORRUPT</code> command specifies the total number of physical and logical corruptions permitted in a data file during a backup job. If the sum of physical and logical corruptions detected for a data file is no more than its <code>MAXCORRUPT</code> setting, then the <code>BACKUP</code> command completes. If more than <code>MAXCORRUPT</code> corrupt blocks exist, then RMAN terminates without creating output files.</p> <p>Whether or not the <code>MAXCORRUPT</code> limit is exceeded, RMAN populates the <code>V\$DATABASE_BLOCK_CORRUPTION</code> view with any corrupt block ranges that it finds. However, a backup or restore job is terminated after <code>MAXCORRUPT+1</code> corrupt blocks are found, so in this case RMAN only records <code>MAXCORRUPT+1</code> corruptions. Any block corruptions beyond the point at which the backup job terminated are not recorded.</p> <p><b>Note:</b> If you specify <code>CHECK LOGICAL</code>, then the <code>MAXCORRUPT</code> limit applies to the sum of logical and physical corruptions detected. Otherwise, <code>MAXCORRUPT</code> only applies to the number of physical block corruptions.</p> <p><b>See Also:</b> <a href="#">datafileSpec</a></p>
<pre>NEWNAME FOR DATABASE</pre>	<p>Sets new default names for all data files and temp files in the specified database that have not been named with the <code>SET NEWNAME FOR TABLESPACE</code>, <code>SET NEWNAME FOR TEMPFILE</code> or <code>SET NEWNAME FOR DATAFILE</code> command.</p> <p>This command enables you to change the names for multiple files in the database and provides a quick alternative to naming each file individually (see <a href="#">Example 2-88</a>). This command does not set names for temp files.</p> <p>When issuing <code>SET NEWNAME FOR DATABASE</code>, you must specify at least one of the following substitution variables to avoid name collisions: <code>%b</code>, <code>%f</code>, and <code>%U</code>. See the semantic entry for <code>TO 'filename'</code> for descriptions of the possible substitution variables.</p> <p>The new names are used for all subsequent <a href="#">DUPLICATE</a>, <a href="#">RESTORE</a>, <a href="#">SWITCH</a> commands that affect the files in the database and when using the RMAN TSPITR utility. If you do not issue this command before the restore operation, then RMAN restores the files to their default locations.</p> <p>You do not have to issue the <code>SET NEWNAME</code> commands in any particular order. For example, assume that you run the following series of commands:</p> <pre>SET NEWNAME FOR DATABASE TO '/oradata1/%b'; SET NEWNAME FOR TABLESPACE users TO '/oradata2/%U'; SET NEWNAME FOR DATAFILE 1 TO '+data';</pre> <p>The preceding series of commands is equivalent to the following differently ordered series of commands:</p> <pre>SET NEWNAME FOR DATAFILE 1 TO '+data'; SET NEWNAME FOR DATABASE TO '/oradata1/%b'; SET NEWNAME FOR TABLESPACE users TO '/oradata2/%U';</pre> <p><b>Note:</b> The <code>SET NEWNAME</code> command supports ASM disk groups.</p> <p><b>See Also:</b> <a href="#">formatSpec</a> to learn about substitution variables that are valid in <code>SET NEWNAME FOR DATABASE</code></p>
<pre>NEWNAME FOR DATABASE ROOT</pre>	<p>In a CDB, sets new default names for data files and temp files only in the root. Connect to the root as a common user with the <code>SYSDBA</code> or <code>SYSBACKUP</code> privilege.</p>

Syntax Element	Description
NEWNAME FOR PLUGGABLE DATABASE <i>pdb_name</i>	<p>In a CDB, sets new default names for data files and temp files only in the specified PDBs. Connect to the root as a common user with the SYSDBA or SYSBACKUP privilege.</p>
NEWNAME FOR DATAFILE <a href="#">datafileSpec</a>	<p>Sets the default name for the specified data file.</p> <p>This command enables you to specify the names of each data file individually (see <a href="#">Example 2-89</a>). The new names are used for all subsequent <a href="#">DUPLICATE</a>, <a href="#">RESTORE</a>, <a href="#">SWITCH</a> commands that affect the files in the database and when using the RMAN TSPITR utility.</p> <p>If you run <code>SET NEWNAME FOR DATAFILE</code> and then restore a data file to a new location, then you can run <a href="#">SWITCH</a> to rename the file in the control file to the NEWNAME. If you do not run <a href="#">SWITCH</a>, then RMAN records the restored file as a data file copy in the RMAN repository.</p> <p><b>Note:</b> The <code>SET NEWNAME</code> command supports ASM disk groups.</p> <p><b>See Also:</b> <a href="#">datafileSpec</a></p>
NEWNAME FOR TABLESPACE <i>tablespace_name</i>	<p>Sets new default names for all the files in the specified tablespace that have not been named with the <code>SET NEWNAME FOR DATAFILE</code> command.</p> <p>This command enables you to change the names for multiple files in the duplicate tablespace and provides an alternative to naming each file of the tablespace individually (see <a href="#">Example 2-89</a>).</p> <p>When issuing <code>SET NEWNAME FOR TABLESPACE</code>, you must specify at least a first three of the following substitution variables to avoid name collisions: <code>%b</code>, <code>%f</code>, and <code>%U</code>. See the semantic entry for <code>TO 'filename'</code> for descriptions of the possible substitution variables.</p> <p>The new names are used for all subsequent <a href="#">DUPLICATE</a>, <a href="#">RESTORE</a> or <a href="#">SWITCH</a> commands that affect the files in the tablespace. If you do not issue this command before the restore operation, then RMAN restores the files to their default locations.</p> <p><b>Note:</b> The <code>SET NEWNAME</code> command supports ASM disk groups.</p> <p><b>See Also:</b> <a href="#">formatSpec</a> to learn about substitution variables that are valid in <code>SET NEWNAME FOR DATABASE</code></p>
NEWNAME FOR TABLESPACE <i>pdb-name:tablespace_name</i>	<p>The name of the tablespace in a CDB. Multiple databases can have tablespaces with the same name. A qualifier before the name uniquely identifies the tablespace. <i>pdb-name</i> is the name of a PDB.</p>
NEWNAME FOR TEMPFILE <a href="#">tempfileSpec</a>	<p>Sets the new temp file name for a subsequent <a href="#">SWITCH</a> command that renames the specified temp file to the specified name.</p> <p><b>Note:</b> The <code>SET NEWNAME</code> command supports ASM disk groups.</p> <p><b>See Also:</b> <a href="#">tempfileSpec</a></p>

Syntax Element	Description
TO 'filename'	<p>Specifies a user-defined file name or ASM disk group for the restored data file or temp file.</p> <p>When issuing <code>SET NEWNAME FOR DATABASE</code> or <code>SET NEWNAME FOR TABLESPACE</code>, you must specify substitution variables within <i>filename</i> to avoid name collisions. Specify at least a first three of the following substitution variables (the %I and %N variables are optional):</p> <ul style="list-style-type: none"> <li>• %b Specifies the file name without the fully qualified directory path. For example, the data file name <code>/oradata/prod/financial.dbf</code> is transformed to <code>financial.dbf</code>. This variable enables you to preserve the names of the data files while you move them to different directory. During backup, you can use it for creating image copies. You cannot use this variable for OMF data files or backup sets.</li> <li>• %f Specifies the absolute file number of the data file for which the new name is generated. For example, if data file 2 is duplicated, then %f generates the value 2.</li> <li>• %U Specifies a system-generated unique file name. The name is in the following format: <code>data-D-%d_id-%I_TS-%N_FNO-%f</code>. The %d variable specifies the database name. For example, a possible name might be <code>data-D-prod_id-22398754_TS-users_FNO-7</code>.</li> <li>• %I Specifies the DBID.</li> <li>• %N Specifies the tablespace name.</li> </ul> <p><b>Note:</b> Use of other substitution variables defined in <a href="#">formatSpec</a> is undefined: some yield an error, while others result in zero values and are not supported.</p> <p>If you set the <code>NEWNAME</code> to an ASM disk group for a data file and run <code>RESTORE</code>, then RMAN restores the file to the disk group. If you specify a file name for a temp file, then it is the new name of the temp file after the database is recovered and opened.</p>
TO NEW	<p>Creates an Oracle-managed file in the directory specified by the <code>DB_CREATE_FILE_DEST</code> initialization parameter.</p> <p>For example, <code>SET NEWNAME FOR TABLESPACE users TO NEW</code> sets OMF names for the data files of the <code>users</code> tablespace to be created in the <code>DB_CREATE_FILE_DEST</code> location (see <a href="#">Example 2-90</a>).</p> <p>If the original file is an Oracle-managed file or is on an ASM disk group, then RMAN attempts to delete the original file. If you specify <code>TO NEW</code> for a temp file, then RMAN creates the temp file in <code>DB_CREATE_FILE_DEST</code> when the database is opened.</p> <p><b>See Also:</b> <i>Oracle Database Administrator's Guide</i> for information about Oracle-managed files</p>



Syntax Element	Description
TO RESTORE POINT <i>restore_point_name</i>	Specifies a restore point for a subsequent <a href="#">RESTORE</a> or <a href="#">RECOVER</a> command, with the SCN at which the restore point was created as the upper, inclusive limit. Because the limit is inclusive, RMAN selects only files that it can use to restore or recover up to <i>and including</i> the SCN corresponding to the restore point.  <b>Note:</b> You can only use <code>SET TO RESTORE POINT</code> when the database is mounted, because the defined restore points are recorded in the control file. For example, you cannot use <code>SET TO RESTORE POINT</code> to specify the target SCN for a <a href="#">RESTORE CONTROLFILE</a> operation.
<a href="#">untilClause</a>	Specifies an end time, SCN, or log sequence number for a subsequent <a href="#">RESTORE</a> or <a href="#">RECOVER</a> command.  <b>See Also:</b> <a href="#">untilClause</a>

### ***setRmanOrRunOption***

This subclass specifies `SET` options that are usable inside or outside of a `RUN` block.

Syntax Element	Description
AUXILIARY INSTANCE PARAMETERFILE TO <i>'filename'</i>	Specifies the path to the parameter file to use in starting the instance. You can use this parameter when customizing TSPITR with an automatic auxiliary instance or when cloning RMAN tablespaces with RMAN.  <b>Note:</b> The <i>filename</i> is on the host running the RMAN client.
COMMAND ID TO <i>'string'</i>	Enters the specified string into the <code>V\$SESSION.CLIENT_INFO</code> column of all channels. Use this information to determine which database server sessions correspond to which RMAN channels. The <code>SET COMMAND ID</code> command applies only to channels that are allocated.  The <code>V\$SESSION.CLIENT_INFO</code> column contains information for each RMAN server session. The data appears in one of the following formats: <ul style="list-style-type: none"> <li><code>id=string</code></li> <li><code>id=string,ch=channel_id</code></li> </ul> The first form appears in the RMAN target database connection. The second form appears in all allocated channels. When the current job is complete, the <code>V\$SESSION.CLIENT_INFO</code> column is cleared.  <b>See Also:</b> <i>Oracle Database Reference</i> for more information about <code>V\$SESSION.CLIENT_INFO</code>
CONTROLFILE AUTOBACKUPFORMAT FOR DEVICE TYPE <a href="#">deviceSpecifier</a> TO <a href="#">formatSpec</a>	Overrides the default file name format for the control file autobackup on the specified device type. You can use this command either in <code>RUN</code> or at the RMAN prompt. The order of precedence is as follows: <ol style="list-style-type: none"> <li><code>SET CONTROLFILE AUTOBACKUP</code> executed within a <code>RUN</code> block</li> <li><code>SET CONTROLFILE AUTOBACKUP</code> executed at the RMAN prompt</li> <li><code>CONFIGURE CONTROLFILE AUTOBACKUP FORMAT</code></li> </ol> The <code>%F</code> substitution variable is required to be in the new <i>formatSpec</i> . No other substitution variable is valid in a control file autobackup <i>formatSpec</i> .  <b>See Also:</b> <a href="#">formatSpec</a> for the semantics of the <code>%F</code> substitution variable
DATABASE <i>'database_name'</i>	Specifies the name of the database to copy (source database) when duplicating without a connection to the target database. Alternatively, you can use the <code>DATABASE</code> clause of the <code>DUPLICATE</code> command to specify the source database when you have chosen not to connect to the target database for the duplicate.

Syntax Element	Description
<code>DBID integer</code>	<p>Specifies the DBID, which is a unique 32-bit identification number computed when the database is created.</p> <p>RMAN displays the DBID upon connection to the target database. You can obtain the DBID by querying the <code>V\$DATABASE</code> view or the <code>RC_DATABASE</code> and <code>RC_DATABASE_INCARNATION</code> recovery catalog views.</p> <p>Run the <code>SET DBID</code> command only in the following specialized circumstances:</p> <ul style="list-style-type: none"> <li>You are not connected to a recovery catalog and want to restore the control file (see <a href="#">Example 3-60</a>). The same restriction applies when you use the Data Recovery Advisor to restore a control file autobackup. <code>CONFIGURE</code> can locate an autobackup and restore it only if <code>SET DBID</code> is issued before <code>ADVISE FAILURE</code>.</li> </ul> <p>Starting in Oracle Database 19c, the Data Recovery Advisor (DRA) feature is deprecated.</p> <p>The deprecation of DRA includes deprecation of the following Oracle Recovery Manager (RMAN) commands: <code>LIST FAILURE</code>, <code>ADVISE FAILURE</code>, <code>REPAIR FAILURE</code>, and <code>CHANGE FAILURE</code>. Database administrators will no longer have access to these commands. There is no replacement feature for DRA.</p> <ul style="list-style-type: none"> <li>You want to restore the server parameter file (see <a href="#">Example 3-61</a>).</li> <li>You are connected to the recovery catalog but not the target database and use the <code>FOR DB_UNIQUE_NAME</code> option on the <code>CONFIGURE</code>, <code>LIST</code>, <code>REPORT</code>, <code>SHOW</code>, or <code>UNREGISTER</code> commands.</li> <li>You are connected to the recovery catalog and want to restore the controlfile but the target database is not mounted and the database name is not unique in the recovery catalog.</li> <li>You are performing a <code>DUPLICATE</code> without a target connection but are not using the <code>DBID</code> subclause in the <code>DUPLICATE</code> command and the database name specified in <code>SET DATABASE</code> or <code>DATABASE</code> clause is not unique in the recovery catalog.</li> </ul>
<code>INCARNATION primaryKey</code>	<p>Specifies an orphan incarnation when duplicating without a target connection under the following conditions:</p> <ul style="list-style-type: none"> <li>You have not specified <code>INCARNATION</code> within the <code>DATABASE</code> clause of the <code>DUPLICATE</code> command.</li> <li>You want to duplicate to an incarnation not in the current incarnation path (orphan incarnation).</li> </ul>
<code>LONG integer</code>	<p>Sets the number of characters displayed for <code>LONG</code> columns. The maximum is 4000, the default is 80.</p>
<code>NUMWIDTH integer</code>	<p>Sets the number of characters displayed for <code>NUMBER</code> columns. The default is 10.</p>

## Examples

### Example 3-58 Setting the Command ID

This example sets the command ID to `rman`, backs up the database, and then archives the online redo logs. You can use the command ID to query `V$SESSION` with `WHERE CLIENT_INFO LIKE '%rman%'` for job status information.

```

RUN
{
  ALLOCATE CHANNEL d1 DEVICE TYPE DISK FORMAT '/disk1/%U';
  ALLOCATE CHANNEL d2 DEVICE TYPE DISK FORMAT '/disk2/%U';
  SET COMMAND ID TO 'rman';
  BACKUP INCREMENTAL LEVEL 0 DATABASE;
}

```

```
ALTER SYSTEM ARCHIVE LOG CURRENT;
}
```

### Example 3-59 Duplexing a Backup Set

Assume that the current duplexing configuration is as follows:

```
CONFIGURE ARCHIVELOG COPIES FOR DEVICE TYPE sbt TO 3;
CONFIGURE DATAFILE COPIES FOR DEVICE TYPE sbt TO 3;
```

A tape drive goes bad, leaving only two available. The guideline for tape backups is that the number of devices equals the number of copies multiplied by the number of channels. The following example overrides the persistent duplexing configuration with `SET BACKUP COPIES` and writes two copies of a database backup to the two functioning tape drives:

```
RUN
{
  ALLOCATE CHANNEL dev1 DEVICE TYPE sbt
    PARMS 'ENV=(OB_DEVICE_1=stape1,OB_DEVICE_2=stape2)';
  SET BACKUP COPIES 2;
  BACKUP DATABASE PLUS ARCHIVELOG;
}
```

### Example 3-60 Setting the Control File Autobackup Format During a Restore

Assume that the disk containing the control file fails. You edit the `CONTROL_FILES` parameter in the initialization parameter file to point to a new location.

In this example, you do not have access to a recovery catalog. The example starts the instance, sets the DBID, and then restores a control file autobackup. After the database is mounted, you can recover the database.

```
CONNECT TARGET /
STARTUP FORCE NOMOUNT
SET DBID 28014364;
RUN
{
  SET CONTROLFILE AUTOBACKUP FORMAT FOR DEVICE TYPE DISK TO '/disk2/cf_%F.bak';
  RESTORE CONTROLFILE FROM AUTOBACKUP MAXSEQ 100;
}
ALTER DATABASE MOUNT;
RECOVER DATABASE;
ALTER DATABASE OPEN RESETLOGS;
```

### Example 3-61 Restoring the Server Parameter File

Assume that the database is shut down while maintenance is being performed on the database host. During this time, the server parameter file is accidentally deleted. You start the RMAN client, `CONNECT` as `TARGET` to the database, and connect to the recovery catalog. The following example restores a server parameter file from an autobackup on tape and then restarts the instance.

```
SET DBID 3257174182; # set dbid so RMAN can identify the database
STARTUP FORCE NOMOUNT # RMAN starts database with a dummy server parameter file
RUN
{
  ALLOCATE CHANNEL t1 DEVICE TYPE sbt;
  RESTORE SPFILE FROM AUTOBACKUP;
}
STARTUP FORCE; # RMAN restarts database with restored server parameter file
```

**Example 3-62 Setting NEWNAME and Duplicating Without a Connection to Target Database**

Assume that you want to duplicate a database without a connection to the target database and that you want to duplicate to an incarnation that is not in the current incarnation path (451). The following example uses the various `SET NEWNAME` commands, sets the `DBID` and duplicates the database to `NEWDB`:

```
SET DATABASE PROD
SET DBID 22398754
SET INCARNATION 451
RUN
{
SET NEWNAME FOR TABLESPACE system TO '/test/oradata/system/%d%f';
SET NEWNAME FOR TABLESPACE users TO '/test/oradata/users/%b';
SET NEWNAME FOR DATAFILE 35 TO '/test/oradata/special/%N_%b%f';
SET NEWNAME FOR DATAFILE 50 TO '/test/oradata/special/%N_%b%f';
SET NEWNAME FOR DATABASE TO NEW;
DUPLICATE DATABASE TO newdb
SKIP READONLY
LOGFILE
GROUP 1 ('/test/onlinelogs/redo01_1.f',
'/?/test/onlinelogs/redo01_2.f') SIZE 4M,
GROUP 2 ('/?/test/onlinelogs/redo02_1.f',
'/?/test/onlinelogs/redo02_2.f') SIZE 4M,
GROUP 3 ('/?/test/onlinelogs/redo03_1.f',
'/?/test/onlinelogs/redo03_2.f') SIZE 4M REUSE;
}
```

**Example 3-63 Setting a Compression Level for a Backup**

This example assumes that you have a license for Advanced Compression Option (ACO) of the database.

To use the `LOW` compression algorithm for a backup of tablespace `users` that has high volatility:

```
SET COMPRESSION ALGORITHM 'LOW' OPTIMIZE FOR LOAD FALSE;
BACKUP AS COMPRESSED BACKUPSET TABLESPACE USERS;
```

## 3.15 SHOW

**Purpose**

Use the `SHOW` command to display the `CONFIGURE` commands used to set the current RMAN configuration for one or more databases. RMAN default configurations are suffixed with `#default`.

**Prerequisites**

Execute this command only at the RMAN prompt. Either of the following conditions must be met:

- RMAN must be connected to a target database, which must be mounted or open.
- RMAN must be connected to a recovery catalog and `SET DBID` must have been run.

## Syntax

**show ::=**

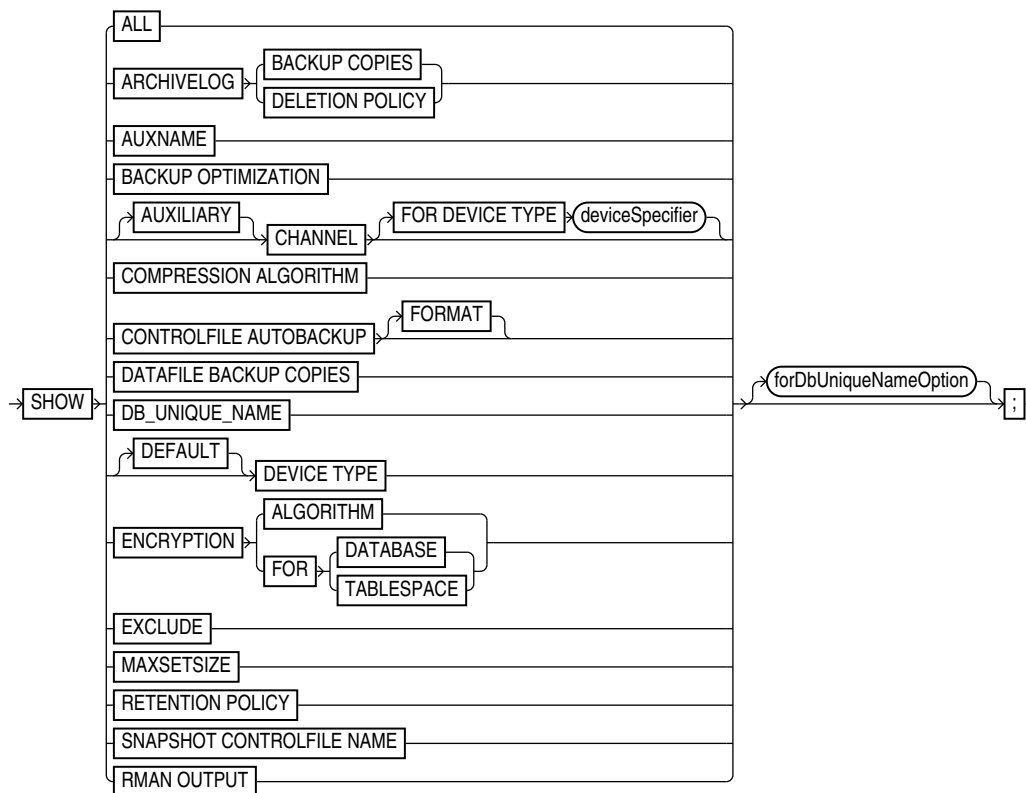

(**deviceSpecifier ::=**)

**forDbUniqueNameOption ::=**

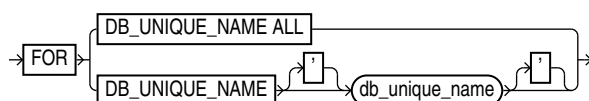

## Semantics

Syntax Element	Description
ALL	Shows all user-entered <a href="#">CONFIGURE</a> commands and default configurations.
ARCHIVELOG BACKUP COPIES	Shows the currently configured degree of duplexing for archived redo log backups.
ARCHIVELOG DELETION POLICY	Shows the <a href="#">CONFIGURE ARCHIVELOG DELETION POLICY</a> setting.
AUXNAME	Shows the <a href="#">CONFIGURE AUXNAME</a> settings.

Syntax Element	Description
BACKUP OPTIMIZATION	Shows the CONFIGURE BACKUP OPTIMIZATION settings: ON or OFF (default).
[AUXILIARY] CHANNEL	Shows the CONFIGURE CHANNEL settings. You can specify a normal channel or an AUXILIARY channel.
FOR DEVICE TYPE <a href="#">deviceSpecifier</a>	Specifies the device type of the channel. For example, SHOW CHANNEL FOR DEVICE TYPE DISK shows only channel settings for disk channels.
COMPRESSION ALGORITHM	Shows the configured backup compression algorithm.
CONTROLFILE AUTOBACKUP	Shows the CONFIGURE CONTROLFILE AUTOBACKUP settings: ON or OFF.
FORMAT	Shows the format for the control file autobackup file for configured devices.
DATAFILE BACKUP COPIES	Shows the CONFIGURE ... BACKUP COPIES setting for data files: 1, 2, 3, or 4.
DB_UNIQUE_NAME	Shows the DB_UNIQUE_NAME values known to the recovery catalog.
[DEFAULT] DEVICE TYPE	Shows the configured device types and parallelism settings. If DEFAULT is specified, then SHOW displays the default device type and settings.
ENCRYPTION	Shows currently configured encryption settings for the database or tablespaces within the database, when used with ALGORITHM or FOR {DATABASE   TABLESPACE}.
ALGORITHM	Shows the configured default algorithm to use for encryption when writing encrypted backup sets. Possible values are listed in V\$RMAN_ENCRYPTION_ALGORITHMS.
FOR DATABASE	Shows current encryption settings for the database.
FOR TABLESPACE	Shows current encryption settings for each tablespace.
EXCLUDE	Shows only the tablespaces that you excluded.
MAXSETSIZE	Shows the CONFIGURE MAXSETSIZE settings.
RETENTION POLICY	Shows the settings for CONFIGURE RETENTION POLICY for the current target database.
SNAPSHOT CONTROLFILE NAME	Shows the CONFIGURE SNAPSHOT CONTROLFILE settings.
<a href="#">forDbUniqueNameOption</a>	Shows the configuration in the recovery catalog for a uniquely named database even when RMAN is not connected to this database as TARGET. You can specify a database with <i>db_unique_name</i> or use ALL for all uniquely named databases. The unique name for a database is the value of its DB_UNIQUE_NAME initialization parameter setting. The FOR DB_UNIQUE_NAME clause is useful for showing the configurations of standby databases in a Data Guard environment. RMAN must be connected to a recovery catalog. RMAN must be connected to a mounted target database or you must identify the target database with SET DBID. For example, you could run SET DBID with the DBID of the target database and then show the configuration for all standby databases known to the recovery catalog (see <a href="#">Example 2-57</a> ). <b>See Also:</b> <a href="#">forDbUniqueNameOption</a> for descriptions of the options in this clause
RMAN OUTPUT	Shows the currently configured value for RMAN output logging.

## Examples

### Example 3-64 Showing All Configurations for a Target Database

Assume that you want to know all persistent RMAN configurations for a target database. You start the RMAN client, [CONNECT](#) to the target database and recovery catalog, and run the `SHOW` command as follows (sample output included):

```

RMAN> SHOW ALL;

RMAN configuration parameters for database with db_unique_name PROD1 are:
CONFIGURE RETENTION POLICY TO REDUNDANCY 1; # default
CONFIGURE BACKUP OPTIMIZATION OFF; # default
CONFIGURE DEFAULT DEVICE TYPE TO DISK; # default
CONFIGURE CONTROLFILE AUTOBACKUP ON;
CONFIGURE CONTROLFILE AUTOBACKUP FORMAT FOR DEVICE TYPE DISK TO '/disk1/oracle/dbs/%F';
CONFIGURE CONTROLFILE AUTOBACKUP FORMAT FOR DEVICE TYPE SBT_TAPE TO '%F'; # default
CONFIGURE DEVICE TYPE DISK PARALLELISM 1 BACKUP TYPE TO BACKUPSET; # default
CONFIGURE DEVICE TYPE SBT_TAPE PARALLELISM 1 BACKUP TYPE TO BACKUPSET; # default
CONFIGURE DATAFILE BACKUP COPIES FOR DEVICE TYPE DISK TO 1; # default
CONFIGURE DATAFILE BACKUP COPIES FOR DEVICE TYPE SBT_TAPE TO 1; # default
CONFIGURE ARCHIVELOG BACKUP COPIES FOR DEVICE TYPE DISK TO 1; # default
CONFIGURE ARCHIVELOG BACKUP COPIES FOR DEVICE TYPE SBT_TAPE TO 1; # default
CONFIGURE CHANNEL DEVICE TYPE 'SBT_TAPE'
  PARMS "SBT_LIBRARY=/usr/local/oracle/backup/lib/libobk.so";
CONFIGURE MAXSETSIZE TO UNLIMITED; # default
CONFIGURE ENCRYPTION FOR DATABASE ON;
CONFIGURE ENCRYPTION ALGORITHM 'AES128'; # default
CONFIGURE COMPRESSION ALGORITHM 'BASIC' AS OF RELEASE 'DEFAULT' OPTIMIZE FOR LOAD TRUE ;
  # default
CONFIGURE RMAN OUTPUT TO KEEP FOR 7 DAYS; # default
CONFIGURE ARCHIVELOG DELETION POLICY TO NONE; # default
CONFIGURE SNAPSHOT CONTROLFILE NAME TO '/disk1/oracle/dbs/cf_snap .f'

```

## 3.16 SHUTDOWN

### Purpose

Use the `SHUTDOWN` command to shut down the target database without exiting RMAN. This command is equivalent to the SQL\*Plus `SHUTDOWN` statement.



#### See Also:

*Oracle Database Administrator's Guide* for information on how to start and shut down a database, and *SQL\*Plus User's Guide and Reference* for `SHUTDOWN` syntax

### Usage Notes

You cannot use the RMAN `SHUTDOWN` command to shut down the recovery catalog database. To shut down this database, start a SQL\*Plus session and issue a `SHUTDOWN` statement.

If the database operates in `NOARCHIVELOG` mode, then you must shut down the database cleanly and then issue a `STARTUP MOUNT` before a making a backup.

## Syntax

**shutdown::=**

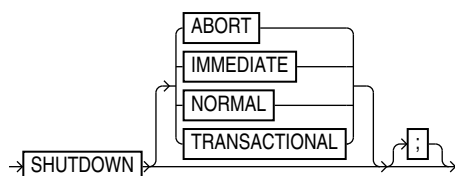

## Semantics

Syntax Element	Description
ABORT	Performs an inconsistent shutdown of the target instance, with the following consequences: <ul style="list-style-type: none"> <li>All current client SQL statements are immediately terminated.</li> <li>Uncommitted transactions are not rolled back until next startup.</li> <li>All connected users are disconnected.</li> <li>Instance recovery is performed on the database at next startup.</li> </ul>
IMMEDIATE	Performs an immediate, consistent shutdown of the target database, with the following consequences: <ul style="list-style-type: none"> <li>Current client SQL statements being processed by the database are allowed to complete.</li> <li>Uncommitted transactions are rolled back.</li> <li>All connected users are disconnected.</li> </ul>
NORMAL	Performs a consistent shutdown of the target database with normal priority (default option), which means: <ul style="list-style-type: none"> <li>No new connections are allowed after the statement is issued.</li> <li>Before shutting down, the database waits for currently connected users to disconnect</li> <li>The next startup of the database does not require instance recovery.</li> </ul>
TRANSACTIONAL	Performs a consistent shut down of the target database while minimizing interruption to clients, with the following consequences: <ul style="list-style-type: none"> <li>Clients currently conducting transactions are allowed to complete, that is, either commit or terminate before shutdown.</li> <li>No client can start a new transaction on this instance; any client attempting to start a new transaction is disconnected.</li> <li>After all transactions have either committed or terminated, any client still connected is disconnected.</li> </ul>

## Examples

### Example 3-65 Shutting Down a Database with the Immediate Option

This example waits for current SQL transactions to be processed before shutting down, then mounts the database:

```
SHUTDOWN IMMEDIATE;
STARTUP MOUNT;
```

### Example 3-66 Shutting Down a Database in NOARCHIVELOG Mode

This example backs up a database running in NOARCHIVELOG mode:



```

STARTUP FORCE DBA;
SHUTDOWN IMMEDIATE;
STARTUP MOUNT;
# executing the preceding commands ensures that database is in proper state
# for NOARCHIVELOG backups
BACKUP DATABASE;
ALTER DATABASE OPEN;

```

## 3.17 SPOOL

### Purpose

Use the `SPOOL` command to direct RMAN output to a log file.



### See Also:

[RMAN](#) for a description of `LOG` files

### Prerequisites

Execute the `SPOOL` command at the RMAN prompt.

### Syntax

**`spool::=`**



### Semantics

Syntax Element	Description
OFF	Turns off spooling.
TO <i>filename</i>	Specifies the name of the log file to which RMAN directs its output. RMAN creates the file if it does not exist, or overwrites the file if it does exist. If the specified file cannot be opened for writing, then RMAN turns <code>SPOOL</code> to OFF and continues execution.
APPEND	Appends the RMAN output to the end of the existing log.

### Example

#### Example 3-67 Spooling RMAN Output to a File

This example directs RMAN output to standard output for configuration of the default device type, spools output of the `SHOW` command to log file `current_config.log`, and then spools output to `db_backup.log` for the whole database backup:

```

CONFIGURE DEFAULT DEVICE TYPE TO sbt;
SPOOL LOG TO '/tmp/current_config.log';
SHOW ALL;

```

```

SPOOL LOG OFF;
SPOOL LOG TO '/tmp/db_backup.log';
BACKUP DATABASE;
SPOOL LOG OFF;

```

## 3.18 SQL

### Purpose

Use the SQL command to execute SQL commands and PL/SQL procedures. This command is easier to use than in Oracle Database 11.2 and earlier releases, because the SQL command does not need to be enclosed in quotation marks and does not need to be prefixed with "SQL". For the original syntax, see [SQL \(Quoted\)](#).



### See Also:

*Oracle Database SQL Language Reference*

### Prerequisites

None

### Syntax

**sqlcommand::=**

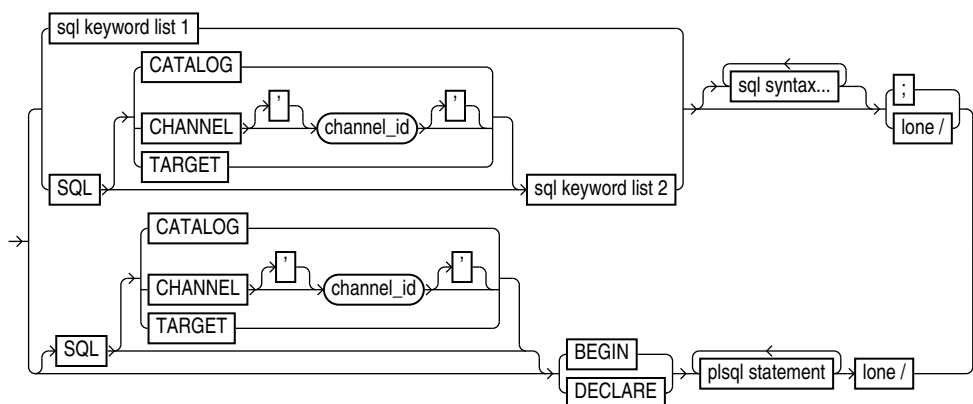

*(sqlKeyword::=, allSqlKeywords::=*

**sqlKeyword ::=**

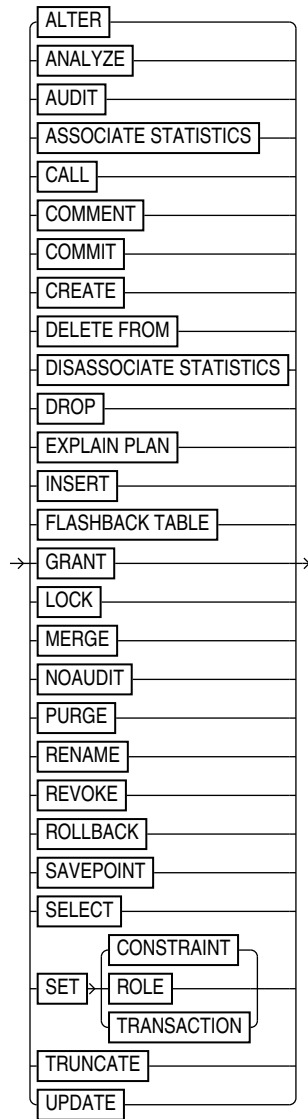

**allSqlKeywords ::=**

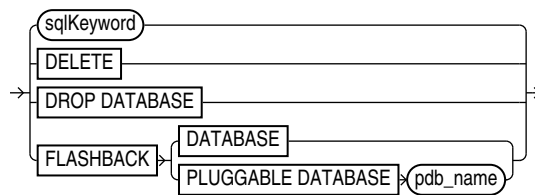

**sqlKeyword ::=**

## Semantics

### ***sqlcommand::=***

Syntax Element	Description
SQL CATALOG	Executes the SQL command in the catalog database.
SQL CHANNEL ' <i>channel_id</i> '	Executes the SQL command over the named channel.
TARGET	Executes the SQL command in the target database.
<i>sql syntax</i>	The appropriate SQL syntax for the specified keyword, which RMAN sends to SQL for processing.
BEGIN	Indicates the body of a PL/SQL block.
DECLARE	Indicates a declarative part of a PL/SQL block.
<i>plsql statement</i>	A PL/SQL statement or block, which RMAN sends to SQL for processing. Bind variables are not supported and cause execution errors. Any output cannot be viewed.
<i>lone /</i>	A single slash (/) as the first and only character on a line.

### ***sqlKeyword::=***

The *sqlkeyword* clause lists the SQL commands that you can execute in RMAN. For the SQL syntax, see the *Oracle Database SQL Language Reference*. The exceptions are described in the following table.

Syntax Element	Description
ALTER	Replaces the RMAN ALTER DATABASE command and provides the full functionality of the SQL ALTER command.
DELETE FROM	Requires the FROM keyword to execute the SQL DELETE command; otherwise, executes the RMAN DELETE command.
DROP DATABASE	Executes the RMAN DROP DATABASE command.
FLASHBACK	Executes the RMAN FLASHBACK DATABASE command.
SELECT	Uses these column widths to display the returned rows: Numbers: 10 characters Characters: Maximum length Long: 80 characters  Use the SQL SET command to change the display size of number and long columns. No other commands or options are available for formatting the output. Bind variables are not supported and cause execution errors. INTO clauses are ignored.

### ***allSqlKeywords::=***

The *allSqlKeywords* clause is preceded by the SQL keyword, which eliminates the ambiguity between SQL and RMAN commands.

Syntax Element	Description
DELETE	Executes the SQL DELETE command.

Syntax Element	Description
DROP DATABASE	Executes the SQL DROP DATABASE command.
FLASHBACK DATABASE	Executes the SQL FLASHBACK command.
FLASHBACK PLUGGABLE DATABASE	Executes the SQL FLASHBACK PLUGGABLE DATABASE command.

### Examples

#### Example 3-68 Adding a Data File

This example adds a data file to the USERS tablespace:

```
RMAN> ALTER TABLESPACE users ADD DATAFILE '/disk1/oradata/users02.dbf' SIZE 1M
AUTOEXTEND ON NEXT 10K MAXSIZE 2M;
```

Statement processed

#### Example 3-69 Querying a Table

This example selects a column from the V\$DATABASE dynamic performance view:

```
RMAN> SELECT dbid FROM v$database;
```

using target database control file instead of recovery catalog

```
      DBID
-----
3152825380
```

#### Example 3-70 Creating a Directory

This example creates the DEST\_DIR directory:

```
RMAN> CREATE DIRECTORY dest_dir AS '/usr/admin/destination';
```

Statement processed

## 3.19 SQL (Quoted)

### Purpose

The SQL command executes a SQL statement or a PL/SQL stored procedure from within RMAN. This syntax is available for compatibility with Oracle Database Release 11.2 and earlier, but for ease of use, refer to [SQL](#).



#### See Also:

*Oracle Database SQL Language Reference*

### Prerequisites

None.

## Syntax

**quotedsqlcommand::=**



## Semantics

Syntax Element	Description
CHANNEL <i>channel_id</i>	Specifies the case-sensitive name of a channel to use when executing an RMAN command within a <a href="#">RUN</a> command.  The channel must first be allocated by <a href="#">ALLOCATE CHANNEL</a> in this <code>RUN</code> command. If you do not set this parameter, then RMAN uses the default channel.
' <i>command</i> '	Specifies a SQL statement for execution (see <a href="#">Example 3-71</a> ). <code>SELECT</code> statements are not permitted.  You must use duplicate single quotes to insert a single quote into a quoted string when the quoted string uses the same style of quoting. For example, if the string that RMAN passes to SQL contains a file name, then the file name must be enclosed in duplicate <i>single</i> quotes and the entire string following the <code>SQL</code> keyword must be enclosed in <i>double</i> quotes (see <a href="#">Example 3-72</a> ).  <b>Note:</b> Because <code>EXECUTE</code> is a SQL*Plus command, you cannot execute a PL/SQL program unit by specifying <code>EXECUTE</code> within the RMAN <code>SQL</code> command. Instead, you must use the <code>BEGIN</code> and <code>END</code> keywords. For example, to execute the PL/SQL procedure <code>rman.rman_purge</code> with the <code>SQL</code> command, issue the following command:  <pre>SQL 'BEGIN rman.rman_purge; END;';</pre>

## Examples

### Example 3-71 Archiving the Unarchived Online Logs

This example backs up a tablespace and then archives all unarchived online redo logs.

```

BACKUP TABLESPACE users;
sql 'ALTER SYSTEM ARCHIVE LOG CURRENT';

```

### Example 3-72 Specifying a File Name Within a Quoted String

This example specifies a file name by using duplicate single quotes within a double-quoted string.

```

sql 'ALTER TABLESPACE users ADD DATAFILE '''/disk1/oradata/users02.dbf'''
    SIZE 100K AUTOEXTEND ON NEXT 10K MAXSIZE 100K';

```

## 3.20 STARTUP

### Purpose

Use the `STARTUP` command to start the target database from within the RMAN environment. This command is equivalent to using the SQL\*Plus `STARTUP` command.

Additionally, the RMAN `STARTUP` command can start an instance in `NOMOUNT` mode even if no server parameter file or initialization parameter file exists. This feature is useful when you must restore a lost server parameter file.

### See Also:

*Oracle Database Administrator's Guide* to learn how to start and shut down a database, and *SQL\*Plus User's Guide and Reference for SQL\*Plus STARTUP* syntax

### Prerequisites

RMAN must be connected to a target database. You can only use this command to start the target database.

### Usage Notes

The RMAN `STARTUP` command can start an instance in `NOMOUNT` mode even if no server parameter file or initialization parameter file exists. This feature is useful when you must restore a lost server parameter file (see [Example 3-74](#)).

### Syntax

**startup::=**

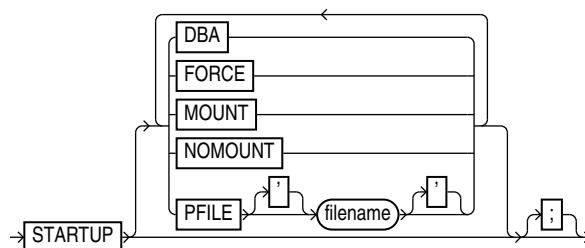

### Semantics

Syntax Element	Description
STARTUP	If you specify only <code>STARTUP</code> with no other options, then the instance starts the instance with the default server parameter file, mounts the control file, and opens the database.
DBA	Restricts access to users with the <code>RESTRICTED SESSION</code> privilege.
FORCE	If the database is open, then <code>FORCE</code> shuts down the database with a <code>SHUTDOWN ABORT</code> statement before re-opening it. If the database is closed, then <code>FORCE</code> opens the database.
MOUNT	Starts the instance, then mounts the database without opening it
NOMOUNT	Starts the instance without mounting the database. If no parameter file exists, then RMAN starts the instance with a temporary parameter file. You can then run <code>RESTORE SPFILE</code> to restore a backup server parameter file.

Syntax Element	Description
<code>PFILE filename</code>	Specifies the file name of the text-based initialization parameter file for the target database. If <code>PFILE</code> is not specified, then the default initialization parameter file name is used.

### Examples

#### Example 3-73 Mounting the Database While Specifying the Parameter File

This example forces a `SHUTDOWN ABORT` and then mounts the database with restricted access, specifying a nondefault initialization parameter file location:

```
CONNECT TARGET /
STARTUP FORCE MOUNT DBA PFILE=/tmp/initPROD.ora;
```

#### Example 3-74 Starting an Instance Without a Parameter File

Assume that the server parameter file was accidentally deleted from the file system. The following example starts an instance without using a parameter file, then runs `RESTORE SPFILE FROM AUTOBACKUP`. In this example, the autobackup location is the fast recovery area, so `SET DBID` is not necessary.

```
CONNECT TARGET /
STARTUP FORCE NOMOUNT; # RMAN starts instance with dummy parameter file
RESTORE SPFILE TO '?/dbs/spfileprod.ora'
FROM AUTOBACKUP
RECOVERY AREA '/disk2' DB_NAME='prod';
STARTUP FORCE; # restart instance with restored server parameter file
```

## 3.21 SWITCH

### Purpose

Use the `SWITCH` command to perform either of the following operations:

- Update the file names for a database, tablespace, or data file to the latest image copies available for the specified files
- Update the file names for data files and temp files for which you have issued a `SET NEWNAME` command

A `SWITCH` updates the names of the files in the RMAN repository, but the database does not rename the files at the operating system level.

### Prerequisites

RMAN must be connected to a target database. When switching tablespaces, data files, or temp files, the files must be offline. When switching the whole database, the database must not be open.

### Usage Notes

The `SWITCH` command deletes the RMAN repository records for the data file copy from the recovery catalog and updates the control file records to status `DELETED`.



If RMAN is connected to a recovery catalog, and if the database is using a control file restored from backup, then `SWITCH` updates the control file with records of any data files known to the recovery catalog but missing from the control file.

Execute `SWITCH ... TO COPY` only at the RMAN prompt. Use `SWITCH` without `TO COPY` only within a `RUN` block.

### Syntax

**switch::=**

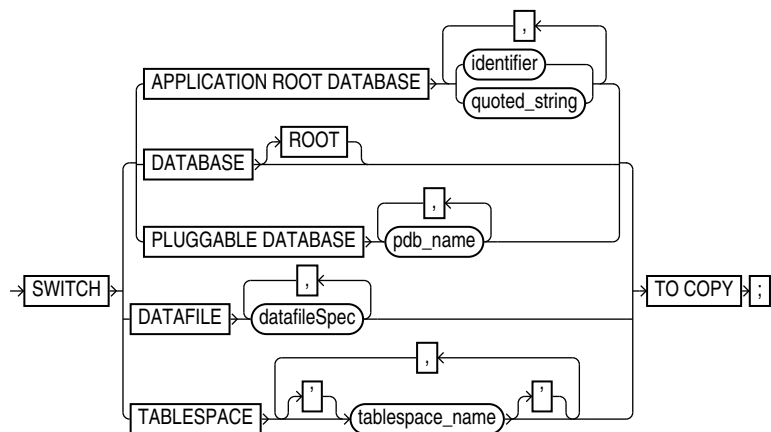

([datafileSpec::=](#))

**switchFile::=**

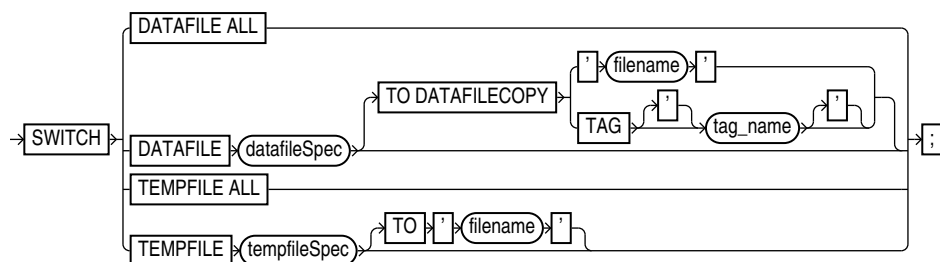

([datafileSpec::=](#), [tempfileSpec::=](#))

### Semantics

#### switch

This subclause switches file names for a database, tablespace, or data file to the latest image copies available for the specified files. By executing this command, you avoid restoring data files from backups. Execute `SWITCH ... TO COPY` only at the RMAN prompt.

Syntax Element	Description
DATABASE	<p>Renames the data files and control files to use the file names of image copies of these files. RMAN switches to the latest image copy of each database file.</p> <p>In a multitenant container database (CDB), switches file names for the root and all pluggable databases (PDBs) in the CDB. In a PDB, switches file names for the connected PDB.</p> <p>After a database switch, RMAN considers the previous database files as data file copies.</p>
DATABASE ROOT	Switches file names for the CDB root. Connect to the root as a common user with the SYSDEBA or SYSBACKUP privilege.
PLUGGABLE DATABASE <i>pdb_name</i>	Renames the data files and control files in one or more PDBs to use the file names of image copies of these files. Use a comma-delimited list to specify multiple PDBs. Connect to the root as a common user or local user with the SYSDBA or SYSBACKUP privilege.
DATAFILE <i>datafileSpec</i>	<p>Switches the specified data files to the latest image copies.</p> <p>After the switch, the control file no longer considers the specified data file as current.</p>
TABLESPACE <i>tablespace_name</i>	<p>Switches all data files within the specified tablespace, as with SWITCH DATAFILE ... TO COPY (see <a href="#">Example 3-75</a>).</p> <p>To switch data files for a tablespace in a PDB, connect to the PDB.</p>
TO COPY	Switches the specified active database files to image copies.

### **switchFile**

This subclause updates the names for data files and temp files for which you have issued a [SET NEWNAME](#) command. Use this clause only within a [RUN](#) block.

Syntax Element	Description
DATAFILE ALL	Switches all data files for which a <a href="#">SET NEWNAME FOR DATAFILE</a> command has been issued in this job to their new names (see <a href="#">Example 3-76</a> ).
DATAFILE <i>datafileSpec</i>	Specifies the data file for renaming. After the switch, the control file no longer considers the specified file as current. If you do not specify a TO option, then RMAN uses the file name specified on a prior <a href="#">SET NEWNAME</a> command in the <a href="#">RUN</a> block for this file as the switch target.
TO DATAFILECOPY {' <i>filename</i> '  TAG <i>tag_name</i> }	Specifies the input copy file for the switch, that is, the data file copy that you intend to rename (see <a href="#">Example 3-78</a> ).
TEMPFILE ALL	Switches all temp files for which a <a href="#">SET NEWNAME FOR TEMPFILE</a> command has been issued in this job to their new names.
TEMPFILE <i>tempfileSpec</i>	Specifies the temp file that you are renaming. If you do not specify a TO option, then RMAN uses the file name specified on a prior <a href="#">SET NEWNAME</a> command in the <a href="#">RUN</a> block for this file as the switch target. The target database must be mounted but not open.
TO ' <i>filename</i> '	Renames the temp file to the specified name (see <a href="#">Example 3-77</a> ). The target database must be mounted but not open.

## Examples

### Example 3-75 Switching to Image Copies to Avoid Restoring from Backup

Assume that a disk fails, rendering all data files in the `users` tablespace inaccessible. Image copies of all data files in this tablespace exist in the fast recovery area. After starting RMAN and connecting to the database as `TARGET`, you can run `SWITCH` to point the control file to the new data files and then run `RECOVER` as follows:

```
ALTER TABLESPACE users OFFLINE IMMEDIATE;
SWITCH TABLESPACE users TO COPY;
RECOVER TABLESPACE users;
ALTER TABLESPACE users ONLINE;
```

### Example 3-76 Switching Data File Names After a Restore to a New Location

Assume that a disk fails, forcing you to restore a data file to a new disk location. After starting RMAN and connecting to the database as `TARGET`, you can use the `SET NEWNAME` command to rename the data file, then `RESTORE` to restore the missing data file. You run `SWITCH` to point the control file to the new data file and then `RECOVER`. This example allocates both disk and tape channels.

```
RUN
{
  ALLOCATE CHANNEL dev1 DEVICE TYPE DISK;
  ALLOCATE CHANNEL dev2 DEVICE TYPE sbt;
  ALTER TABLESPACE users OFFLINE IMMEDIATE;
  SET NEWNAME FOR DATAFILE '/disk1/oradata/prod/users01.dbf'
    TO '/disk2/users01.dbf';
  RESTORE TABLESPACE users;
  SWITCH DATAFILE ALL;
  RECOVER TABLESPACE users;
  ALTER TABLESPACE users ONLINE;
}
```

### Example 3-77 Renaming Tempfiles Using SET NEWNAME and SWITCH TEMPFILE ALL

This example demonstrates using `SET NEWNAME` to specify new names for several temp files, and `SWITCH TEMPFILE ALL` to rename the temp files to the specified names. The database must be closed at the beginning of this procedure. The temp files are re-created at the new locations when the database is opened.

```
CONNECT TARGET /
STARTUP FORCE MOUNT
RUN
{
  SET NEWNAME FOR TEMPFILE 1 TO '/disk2/temp01.dbf';
  SET NEWNAME FOR TEMPFILE 2 TO '/disk2/temp02.dbf';
  SET NEWNAME FOR TEMPFILE 3 TO '/disk2/temp03.dbf';
  SWITCH TEMPFILE ALL;
  RESTORE DATABASE;
  RECOVER DATABASE;
  ALTER DATABASE OPEN;
}
```

### Example 3-78 Switching to a Data File Copy

The following command switches the data file in the `TOOLS` tablespace to the data file copy named `/disk2/tools.copy`:

```
RUN
{
  ALTER TABLESPACE tools OFFLINE IMMEDIATE;
  SWITCH DATAFILE '/disk1/oradata/prod/tools01.dbf'
  TO DATAFILECOPY '/disk2/tools.copy';
  RECOVER TABLESPACE tools;
  ALTER TABLESPACE tools ONLINE;
}
```

## 3.22 TRANSPORT TABLESPACE

### Purpose

Use the `TRANSPORT TABLESPACE` command to create transportable tablespace sets from RMAN backups instead of the live data files of the source database.



#### See Also:

*Oracle Database Backup and Recovery User's Guide* to learn how to transport tablespaces with RMAN

### Prerequisites

The limitations on creating transportable tablespace sets described in *Oracle Database Administrator's Guide* apply to transporting tablespaces from backup, except the requirement to make the tablespaces read-only.

The `SYSAUX` tablespace must not be part of the recovery set, which is the set of tablespaces to be transported. RMAN enforces inclusion of the `SYSAUX` tablespace in the auxiliary set, which contains data files and other files required for the tablespace transport.

`TRANSPORT TABLESPACE` does not convert endian formats. If the target platform has a different endian format, then after running `TRANSPORT TABLESPACE` use the `CONVERT` command to convert the endian format of the transportable set data files.

If you drop a tablespace, then you cannot later use `TRANSPORT TABLESPACE` to include this tablespace in a transportable tablespace set, even if the SCN for `TRANSPORT TABLESPACE` is earlier than the SCN at which the table was dropped. If you rename a tablespace, then you cannot use `TRANSPORT TABLESPACE` to create a transportable tablespace set as of a point in time before the tablespace was renamed.

### Backups and Backup Metadata

You must have a backup of all needed tablespaces (including those in the auxiliary set) and archived redo log files needed to recover to the target point in time.

If you do not use a recovery catalog, and if the database has re-used control file records containing metadata about required backups, then the command fails because RMAN cannot locate the backups. You may be able to use `CATALOG` to add backups to the RMAN

repository, but if the database is overwriting control file records, you may lose records of other backups.

### Data Pump Export and Import

Because the RMAN uses the Data Pump Export and Import utilities, you cannot use `TRANSPORT TABLESPACE` if the tablespaces to be transported use `XMLType`. In this case you must use the procedure in *Oracle Database Administrator's Guide*.

If a file under the name of the export dump file exists in the tablespace destination, then `TRANSPORT TABLESPACE` fails when it calls Data Pump Export. If you are repeating a previous `TRANSPORT TABLESPACE` job, then make sure to delete the previous output files, including the export dump file.

### Tablespace and Column Encryption

The following database encryption features both use the Oracle software keystore: Transparent Data Encryption (TDE) column encryption, which functions at the column level, and TDE tablespace encryption. Note the following restrictions for tablespaces that are encrypted or contain encrypted columns:

- If you are transporting an encrypted tablespace and if the destination database does not have a keystore, then you must manually copy the keystore to the destination database.
- If the destination database has an existing keystore, then you must ensure to export the master keys from the source database and import the keys into the existing keystore on the destination database. See *Exporting a TDE Master Encryption Key* in the *Oracle Database Advanced Security Guide* to learn more.

Alternatively, you can also merge the software keystore from the source database to the destination database. See *Merging One TDE Wallet into an Existing TDE Wallet* in the *Oracle Database Advanced Security Guide* to learn more.



#### See Also:

*Oracle Database Advanced Security Guide* to learn about TDE

### Usage Notes

Because RMAN creates the automatic auxiliary instance used for restore and recovery on the same node as the source instance, there is some performance overhead during the operation of the `TRANSPORT TABLESPACE` command.

If RMAN is not part of the backup strategy for your database, then you can still use `TRANSPORT TABLESPACE` if the needed data file copies and archived redo log files are available on disk. Use the `CATALOG` command to record the data file copies and archived redo log files in the RMAN repository. You can then use `TRANSPORT TABLESPACE`. You also have the option of using RMAN to back up your database specifically so you can use `TRANSPORT TABLESPACE`.

### Syntax

**`transpt_tbs::=`**

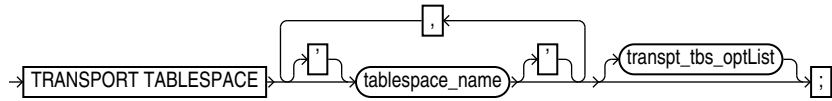

([transpt\\_tbs\\_optlist::=](#))

**transpt\_tbs\_optlist::=**

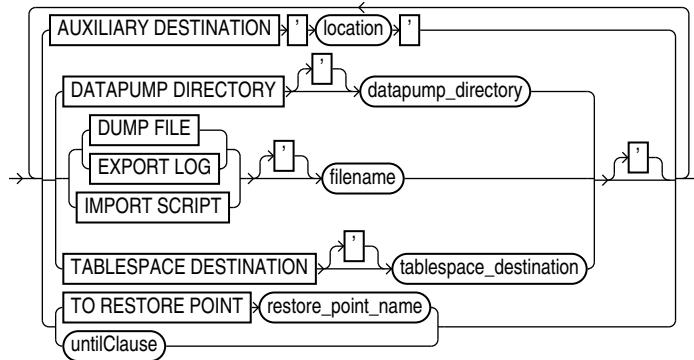

([untilClause::=](#))

**Semantics**

**transpt\_tbs**

Syntax Element	Description
<i>tablespace_name</i>	Specifies the name of each tablespace to transport. You must have a backup of all needed tablespaces (including those in the auxiliary set) and archived redo log files available for use by RMAN that can be recovered to the target time for the <code>TRANSPORT TABLESPACE</code> operation.

**transpt\_tbs\_optlist**

This subclause specifies optional parameters that affect the tablespace transport.

Syntax Element	Description
<code>AUXILIARY DESTINATION'location'</code>	Specifies the location for files for the auxiliary instance. You can use <code>SET NEWNAME</code> and <code>CONFIGURE AUXNAME</code> to override this argument for individual files. If using your own initialization parameter file to customize the auxiliary instance, then you can use the <code>DB_FILE_NAME_CONVERT</code> and <code>LOG_FILE_NAME_CONVERT</code> initialization parameters instead of <code>AUXILIARY DESTINATION</code> . <b>See Also:</b> <i>Oracle Database Backup and Recovery User's Guide</i> for details on the interactions among the different techniques for naming the auxiliary instance files

Syntax Element	Description
<code>DATAPUMP DIRECTORY</code> <code>datapump_directory</code>	Specifies a database directory object where Data Pump Export outputs are created (see <a href="#">Example 3-80</a> ). If not specified, then RMAN creates files in the location specified by <code>TABLESPACE DESTINATION</code> .  <b>See Also:</b> <i>Oracle Database Utilities</i> for more details on Data Pump Export and database directory objects
<code>DUMP FILE 'filename'</code>	Specifies where to create the Data Pump Export dump file. If not specified, the export dump file is named <code>dmpfile.dmp</code> and stored in the location specified by the <code>DATAPUMP DIRECTORY</code> clause or in the tablespace destination.  <b>Note:</b> If a file under the name of the export dump file exists in the tablespace destination, then <code>TRANSPORT TABLESPACE</code> fails when it calls Data Pump Export. If you are repeating a previous <code>TRANSPORT TABLESPACE</code> job, then make sure to delete the previous output files, including the export dump file.
<code>EXPORT LOG 'filename'</code>	Specifies the location of the log generated by Data Pump Export. If omitted, the export log is named <code>explog.log</code> and stored in the location specified by the <code>DATAPUMP DIRECTORY</code> clause or in the tablespace destination.
<code>IMPORT SCRIPT 'filename'</code>	Specifies the file name for the sample input script generated by RMAN for use in plugging in the transported tablespace at the destination database. If omitted, the import script is named <code>impscript.sql</code> . The script is stored in the tablespace destination.
<code>TABLESPACE DESTINATION</code> <code>tablespace_destination</code>	Specifies the location of the data files for the transported tablespaces after the tablespace transport operation completes.
<code>TO RESTORE POINT</code> <code>restore_point_name</code>	Specifies a restore point for tablespace restore and recovery, with the SCN at which the restore point was created as the upper, inclusive limit. Because the limit is inclusive, RMAN selects only files that it can use to restore or recover tablespaces up to <i>and including</i> the SCN corresponding to the restore point.
<a href="#">untilClause</a>	Specifies a past time, SCN, or log sequence number (see <a href="#">Example 3-79</a> ). If specified, RMAN restores and recovers the tablespaces at the auxiliary instance to their contents at that past point in time before export.  If you rename a tablespace, then you cannot use this command to create a transportable tablespace set as of a point in time before the tablespace was renamed. RMAN has no knowledge of the previous name of the tablespace.  Tablespaces including undo segments as of the <code>UNTIL</code> time or SCN for <code>TRANSPORT TABLESPACE</code> must be part of the auxiliary set. The control file only contains a record of tablespaces that include undo segments at the current time. If the set of tablespaces with undo segments was different at the <code>UNTIL</code> time or SCN, then <code>TRANSPORT TABLESPACE</code> fails. Thus, if you use RMAN in <code>NOCATALOG</code> mode and specify <code>UNTIL</code> , then the set of tablespaces with undo segments at the time <code>TRANSPORT TABLESPACE</code> executes must equal the set of tablespaces with undo segments at the <code>UNTIL</code> time or SCN.

## Examples

### Example 3-79 Using TRANSPORT TABLESPACE with a Past Time

In this example, the tablespaces for the transportable set are `example` and `tools`, the transportable set files are to be stored at `/disk1/transport_dest`, and the transportable tablespaces are to be recovered to a time 15 minutes ago:

```
TRANSPORT TABLESPACE example, tools
  TABLESPACE DESTINATION '/disk1/transportdest'
  AUXILIARY DESTINATION '/disk1/auxdest'
  UNTIL TIME 'SYSDATE-15/1440';
```

**Partial sample output follows:**

```
Creating automatic instance, with SID='egnr'

initialization parameters used for automatic instance:
db_name=PROD
compatible=11.0.0
db_block_size=8192
.
.
.
starting up automatic instance PROD
.
.
.
executing Memory Script

executing command: SET until clause

Starting restore at 07-JUN-13
allocated channel: ORA_AUX_DISK_1
channel ORA_AUX_DISK_1: SID=44 device type=DISK

channel ORA_AUX_DISK_1: starting datafile backup set restore
channel ORA_AUX_DISK_1: restoring control file
.
.
.
output file name=/disk1/auxdest/cntrl_tspitr_PROD_egnr.f
Finished restore at 07-JUN-13

sql statement: alter database mount clone database

sql statement: alter system archive log current

sql statement: begin dbms_backup_restore.AutoBackupFlag(FALSE); end;

starting full resync of recovery catalog
full resync complete
.
.
.
executing Memory Script
.
.
.

Starting restore at 07-JUN-13
using channel ORA_AUX_DISK_1

channel ORA_AUX_DISK_1: starting datafile backup set restore
channel ORA_AUX_DISK_1: specifying datafile(s) to restore from backup set
channel ORA_AUX_DISK_1: restoring datafile 00001 to /disk1/auxdest/TSPITR_PROD_EGNR/
datafile/ol_mf_system_%u_.dbf
datafile 1 switched to datafile copy
.
.
.
starting media recovery
.
.
```



```

.
Finished recover at 07-JUN-13

database opened
.
.
.
executing Memory Script
.
.
.
sql statement: alter tablespace EXAMPLE read only
Removing automatic instance
shutting down automatic instance
Oracle instance shut down
Automatic instance removed
auxiliary instance file /disk1/auxdest/cntrl_tspitr_PROD_egnr.f deleted
.
.
.

```

### Example 3-80 Using TRANSPORT TABLESPACE with Customized File Locations

This example illustrates the use of the optional arguments that control the locations of Data Pump-related files such as the dump file. The `DATAPUMP DIRECTORY` must refer to an object that exists in the target database. Use the `CREATE DIRECTORY SQL` statement to create a directory object.

```

TRANSPORT TABLESPACE example
  TABLESPACE DESTINATION '/disk1/transportdest'
  AUXILIARY DESTINATION '/disk1/auxdest'
  DATAPUMP DIRECTORY mypumpdir
  DUMP FILE 'mydumpfile.dmp'
  IMPORT SCRIPT 'myimportscript.sql'
  EXPORT LOG 'myexportlog.log';

```

## 3.23 UNREGISTER

### Purpose

Use the `UNREGISTER` command to remove the RMAN metadata for one or more registered databases from the recovery catalog.



#### See Also:

[DROP DATABASE](#) to learn how to delete a database and unregister it with one command

### Prerequisites

Execute this command only at the RMAN prompt. RMAN must be connected to a recovery catalog. The database to unregister must be currently registered in this catalog.

## Usage Notes

The UNREGISTER command cannot be used when the target database is configured to create backups to Zero Data Loss Recovery Appliance, commonly known as Recovery Appliance. In this case, use the DBMS\_RA.DELETE\_DB procedure to unregister a database from Recovery Appliance.

### See Also:

*Zero Data Loss Recovery Appliance Administrator's Guide* for information about the DBMS\_RA.DELETE\_DB procedure

## Syntax

**unregister::=**

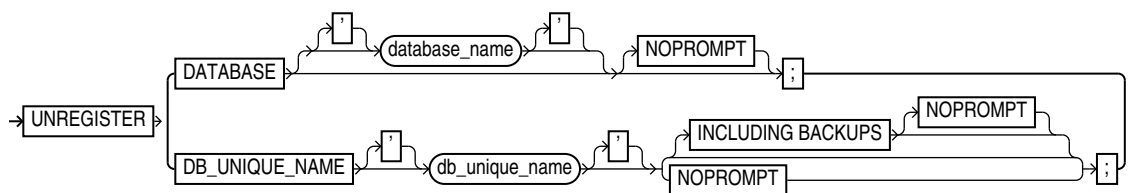

## Semantics

Syntax Element	Description
DATABASE	Specifies a primary database to be unregistered. RMAN unregisters the primary database and any of its associated standby databases (see <a href="#">Example 3-81</a> ). If <i>database_name</i> is not specified, then RMAN must identify the database in one of the following ways: <ul style="list-style-type: none"> <li>• If RMAN is connected to a database as TARGET, then RMAN unregisters the target database and any associated standby databases.</li> <li>• If RMAN is not connected to a database as TARGET, or if the name of the TARGET database is not unique in the recovery catalog, then RMAN uses the value specified in the SET DBID command (see <a href="#">Example 3-82</a>). RMAN unregisters all databases with this DBID.</li> </ul>
<i>database_name</i>	Specifies the name of the primary database that you are unregistering. This database name must be unique in the recovery catalog. Because the database name is unique, RMAN does not need to be connected to a target database or use the SET DBID command.

Syntax Element	Description
<code>DB_UNIQUE_NAME</code> <code>db_unique_name</code>	<p>Removes all metadata except backup metadata for the Data Guard database specified by <code>db_unique_name</code>.</p> <p>The specified database can be either a primary or standby database, although typically you use this clause to unregister a standby database (see <a href="#">Example 3-83</a>).</p> <p>You can use this clause only when RMAN is connected to a mounted or open target database or the <code>SET DBID</code> command has been run. Typically, the target database is not the database that you are unregistering. For example, you can connect as <code>TARGET</code> to <code>prod1</code> and use <code>DB_UNIQUE_NAME</code> to unregister <code>standby1</code>. The DBID used in <code>SET DBID</code> is the same for the primary database and its associated standby databases.</p> <p>The backups of a database have the <code>DB_UNIQUE_NAME</code> associated with the backup file names in the recovery catalog. When a database is unregistered, the database name for these backup files is marked as <code>null</code>. You can associate a database name with these files by using the <code>CHANGE ... RESET DB_UNIQUE_NAME</code> command.</p>
<code>INCLUDING BACKUPS</code>	<p>Removes backup metadata for the database specified by <code>db_unique_name</code>.</p> <p><b>Note:</b> This clause cannot be used when unregistering standby databases.</p> <p><b>Note:</b> Physical backups are not deleted by the <code>UNREGISTER</code> command. If you want the physical backups removed, then first remove them with the <code>DELETE</code> command and then execute <code>UNREGISTER</code> with the <code>INCLUDING BACKUPS</code> option.</p>
<code>NOPROMPT</code>	Does not prompt for confirmation before unregistering the database.

## Example

### Example 3-81 Unregistering a Primary Database and Its Standby Databases

Assume that primary database `prod` has associated standby databases `dgprod3` and `dgprod4`. In this example, you connect RMAN to target database `prod`, whose database name is unique in the recovery catalog, and unregister it. RMAN removes all metadata about `prod`, `dgprod3`, and `dgprod4` from the catalog. Sample output is included.

```

RMAN> CONNECT TARGET /

connected to target database: PROD (DBID=1627709917)

RMAN> CONNECT CATALOG rco@catdb

recovery catalog database Password: password
connected to recovery catalog database

RMAN> UNREGISTER DATABASE NOPROMPT;

database name is "PROD" and DBID is 1627709917
database unregistered from the recovery catalog

RMAN> LIST DB_UNIQUE_NAME ALL;

RMAN>

```

### Example 3-82 Unregistering a Database That is Not Unique in Catalog

Assume that two databases registered in a recovery catalog have the name `prod`. Your goal is to unregister the `prod` database that has the DBID 28014364. Because multiple databases called `prod` are registered in the recovery catalog, and because RMAN is not connected as TARGET to the 28014364 database (which has been deleted from the file system), you run `SET DBID` before `UNREGISTER DATABASE`. This example includes sample output.

```

RMAN> CONNECT CATALOG rco@catdb

recovery catalog database Password: password
connected to recovery catalog database

RMAN> SET DBID 28014364;

executing command: SET DBID
database name is "PROD" and DBID is 28014364

RMAN> UNREGISTER DATABASE;

Do you really want to unregister the database (enter YES or NO)? YES
database unregistered from the recovery catalog
```

### Example 3-83 Unregistering a Standby Database

Assume that primary database `prod` has associated standby databases `dgprod3` and `dgprod4`. You want to unregister `dgprod4`, but not remove the metadata for backups taken on this database because these backups are still usable by other databases in the environment. This example uses `SET DBID` to specify the DBID of the standby database and then unregisters it (sample output included):

```

RMAN> CONNECT CATALOG rco@catdb

recovery catalog database Password: password
connected to recovery catalog database

RMAN> SET DBID 1627367554;

executing command: SET DBID
database name is "PROD" and DBID is 1627367554

RMAN> UNREGISTER DB_UNIQUE_NAME dgprod4;

database db_unique_name is "dgprod4", db_name is "PROD" and DBID is 1627367554

Want to unregister the database with target db_unique_name (enter YES or NO)? YES
database with db_unique_name dgprod4 unregistered from the recovery catalog
```

## 3.24 UPGRADE CATALOG

### Purpose

Use the `UPGRADE CATALOG` command to upgrade a recovery catalog schema from an older version to the version required by the RMAN client.

## Prerequisites

RMAN must be connected to the recovery catalog database, which must be open, as the owner of the recovery catalog. You cannot use the `UPGRADE CATALOG` command while connected to a virtual private catalog (see [CREATE CATALOG](#) command). Only the base catalog can be upgraded.

The recovery catalog must not already be at a version greater than needed by the RMAN executable; otherwise, RMAN issues an error. RMAN displays all error messages generated during the upgrade in the message log.

The Oracle Database 10gR1 version of the recovery catalog schema requires the `CREATE TYPE` privilege. If you created the recovery catalog owner in a release before 10gR1, and if you granted the `RECOVERY_CATALOG_OWNER` role to this user when the role did not include the `CREATE TYPE` privilege, then you must grant `CREATE TYPE` to this user explicitly before performing the upgrade.

If you are upgrading a recovery catalog to Oracle Database 12c Release 2 (12.2) or higher, then you must run the `dbmsrmansys.sql` script that manages recovery catalog privileges. Additionally, if virtual private catalogs are used, then you must run the `dbmsrmanvpc.sql` script that upgrades virtual private catalogs. Starting with Oracle Database 12c Release 1 (12.1.0.2), the recovery catalog database must use Oracle Database Enterprise Edition.

## Usage Notes

RMAN prompts you to enter the `UPGRADE CATALOG` command two consecutive times to confirm the upgrade. To bypass the additional confirmation step, enter the `UPGRADE CATALOG` command with the `NOPROMPT` option while running it the first time.

RMAN permits the command to be run if the recovery catalog is already current so that the packages can be re-created if necessary.

If an upgrade to a base recovery catalog requires changes to an existing virtual private catalog, then RMAN makes these changes automatically the next time RMAN connects to that virtual private catalog.

The `UPGRADE CATALOG` command does not run scripts to perform an upgrade. Instead, RMAN sends various SQL DDL statements to the recovery catalog to update the recovery catalog schema with new tables, views, columns, and so on.

## Syntax

***upgradeCatalog::=***

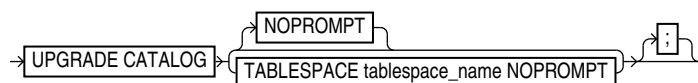

## Semantics

### **NOPROMPT**

Bypasses the confirmation step while upgrading the catalog.

**TABLESPACE *tablespace\_name* NOPROMPT**

Bypasses the confirmation step while upgrading the specified tablespace.

**Example****Example 3-84 Upgrading a Recovery Catalog**

This example connects RMAN to recovery catalog database `catdb` and then upgrades it to a more current version:

```

RMAN> CONNECT CATALOG rco@catdb

recovery catalog database Password: password
connected to recovery catalog database
PL/SQL package RCO.DBMS_RCVCAT version 11.02.00.04 in RCVCAT database is too old

RMAN> UPGRADE CATALOG;

recovery catalog owner is RCO
enter UPGRADE CATALOG command again to confirm catalog upgrade

RMAN> UPGRADE CATALOG;

recovery catalog upgraded to version 12.02.00.00
DBMS_RCVMAN package upgraded to version 12.02.00.00
DBMS_RCVCAT package upgraded to version 12.02.00.00
```

## 3.25 VALIDATE

**Purpose**

Use the `VALIDATE` command to check for corrupt blocks and missing files, or to determine whether a backup set can be restored.

If `VALIDATE` detects a problem during validation, then RMAN displays it and triggers execution of a failure assessment. If a failure is detected, then RMAN logs it into the Automated Diagnostic Repository. You can use `LIST FAILURE` to view the failures.

**Note:**

Starting in Oracle Database 19c, the Data Recovery Advisor (DRA) feature is deprecated.

The deprecation of DRA includes deprecation of the following Oracle Recovery Manager (RMAN) commands: `LIST FAILURE`, `ADVISE FAILURE`, `REPAIR FAILURE`, and `CHANGE FAILURE`. Database administrators will no longer have access to these commands. There is no replacement feature for DRA.

**Prerequisites**

The target database must be mounted or open.

## Usage Notes

The options in the `VALIDATE` command are semantically equivalent to options in the `BACKUP VALIDATE` command. Unlike `BACKUP VALIDATE`, however, `VALIDATE` can check individual backup sets and data blocks.

The `VALIDATE` command does not skip any blocks during validation. If RMAN does not read a block because of unused block compression, and if the block is corrupt, then RMAN does not detect the corruption. A corrupt unused block is not harmful.

In a physical corruption, the database does not recognize the block at all. In a logical corruption, the contents of the block are logically inconsistent. By default, the `VALIDATE` command checks for physical corruption only. You can specify `CHECK LOGICAL` to check for logical corruption as well. RMAN populates the `V$DATABASE_BLOCK_CORRUPTION` view with its findings.

Block corruptions can be divided into interblock corruption and intrablock corruption. In intrablock corruption, the corruption occurs within the block itself and can be either physical or logical corruption. In interblock corruption, the corruption occurs between blocks and can only be logical corruption. The `VALIDATE` command checks for intrablock corruptions only.

## Syntax

**`validate::=`**

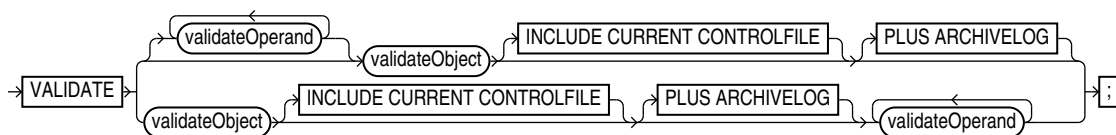

(`validateObject::=`, `validateOperand::=`)

**`validateObject::=`**

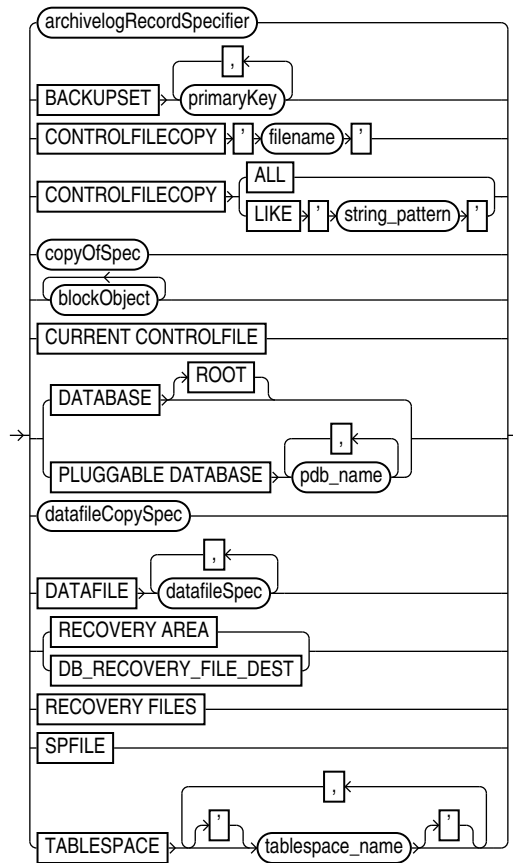

(archiveLogRecordSpecifier::=, copyOfSpec::=, blockObject::=, datafileCopySpec::=, datafileSpec::=)

**copyOfSpec::=**

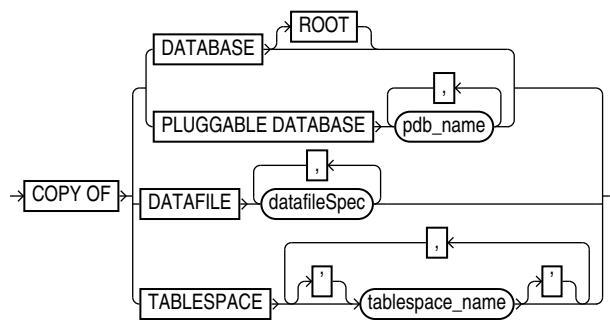

(datafileSpec::=)

**blockObject::=**



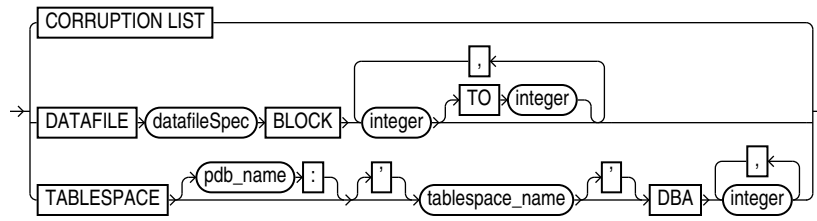

(datafileSpec::=)

**validateOperand::=**

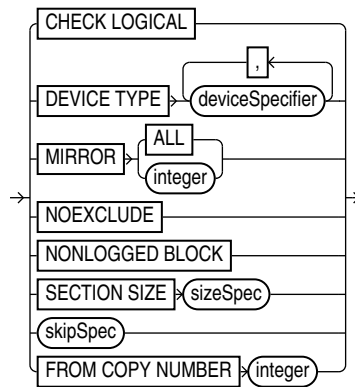

(deviceSpecifier::=, sizeSpec::=, skipSpec::=)

**skipSpec::=**

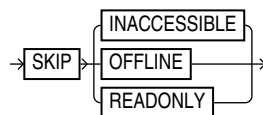

### Semantics

#### validate

This subclause specifies backup sets for validation. Refer to [validate::=](#) for syntax.

Syntax Element	Description
<a href="#">validateOperand</a>	Specifies options that control the validation. <b>See Also:</b> <a href="#">validateOperand</a>
<a href="#">validateObject</a>	Specifies the files to be validated. <b>See Also:</b> <a href="#">validateObject</a>
INCLUDE CURRENT CONTROLFILE	Creates a snapshot of the current control file and validates it.

Syntax Element	Description
PLUS ARCHIVELOG	<p>Includes archived redo log files in the validation. Causes RMAN to perform the following steps:</p> <ol style="list-style-type: none"> <li>1. Run an ALTER SYSTEM ARCHIVE LOG CURRENT statement.</li> <li>2. Run the VALIDATE ARCHIVELOG ALL command. If backup optimization is enabled, then RMAN only validates logs that have not yet been backed up.</li> <li>3. Validate the files specified in the VALIDATE command.</li> <li>4. Run an ALTER SYSTEM ARCHIVE LOG CURRENT statement.</li> <li>5. Validate any remaining archived redo log files.</li> </ol>

### *validateObject*

This subclause specifies database files for validation. Refer to [validateObject::=](#) for syntax.

Syntax Element	Description
<a href="#">archivelogRecordSpecifier</a>	Validates a range of archived redo log files. VALIDATE ARCHIVELOG is equivalent to BACKUP VALIDATE ARCHIVELOG.
BACKUPSET <i>primary_key</i>	<p>Checks that the backup sets specified by <i>primary_key</i> exist and can be restored.</p> <p>You can obtain the primary keys of backup sets by executing a <a href="#">LIST</a> statement or, if you use a recovery catalog, by querying the RC_BACKUP_SET recovery catalog view.</p> <p>The VALIDATE BACKUPSET command checks every block in the backup set to ensure that the backup is restorable. If RMAN finds block corruption, then it issues an error and terminates the validation. In contrast, the <a href="#">CROSSCHECK</a> command examines the headers of the specified files if they are on disk or queries the media management catalog if they are on tape.</p> <p>Use VALIDATE BACKUPSET when you suspect that one or more backup pieces in a backup set are missing or have been damaged. VALIDATE BACKUPSET selects which backups to test, whereas the VALIDATE option of the <a href="#">RESTORE</a> command lets RMAN choose which backups to validate. For validating image copies, run RESTORE VALIDATE FROM DATAFILECOPY.</p> <p>If you do not have automatic channels configured, then manually allocate at least one channel before executing VALIDATE BACKUPSET.</p> <p><b>Note:</b> If multiple copies of a backup set exist, then RMAN validates only the most recent copy. The VALIDATE command does not support an option to validate a specific copy. If one copy is on a different device from another copy, however, then you can use VALIDATE DEVICE TYPE to validate the copy on the specified device. If both copies exist on the same device, then you can use <a href="#">CHANGE</a> to make one copy temporarily UNAVAILABLE and then reissue VALIDATE.</p>

Syntax Element	Description
CONTROLFILECOPY{'filename'   ALL   LIKE 'string_pattern'}	<p>Validates control file copies. You can specify a control file copy in one of the following ways:</p> <ul style="list-style-type: none"> <li>'filename' specifies a control file copy by file name.</li> <li>ALL specifies all control file copies.</li> <li>LIKE 'pattern' specifies a file name pattern that matches one or more control file copies. The percent sign (%) is a wildcard matching zero or more characters; an underscore (_) is a wildcard matching one character.</li> </ul> <p>The control file copy can be created with the <a href="#">BACKUP AS COPY CURRENT CONTROLFILE</a> command or the SQL statement <code>ALTER DATABASE BACKUP CONTROLFILE TO '...'</code>.</p>
<a href="#">copyOfSpec</a>	<p>Validates image copies of data files and control files.</p> <p><b>See Also:</b> <a href="#">copyOfSpec</a> for details.</p>
CURRENT CONTROLFILE	Validates the current control file.
DATABASE	<p>Validates the whole CDB. Connect to the root as a common user with the SYSDBA or SYSBACKUP privilege.</p> <p>When connected to a pluggable database (PDB), validates the PDB.</p> <p>RMAN validates all data files and control files. If the database is currently using a server parameter file, then RMAN validates the server parameter file.</p> <p><b>Note:</b> The online redo log files and temp files are not validated.</p>
DATABASE ROOT	Validates only the CDB root.
PLUGGABLE DATABASE <i>pdb_name</i>	<p>In a CDB, validates the specified PDBs. Use a comma-delimited list to specify multiple PDBs. Connect to the root as a common user or local user with the SYSDBA or SYSBACKUP privilege.</p>
<a href="#">datafileCopySpec</a>	<p>Validates one or more data file image copies.</p> <p>When validating data file copies, RMAN checks for block corruption but does not terminate the validation if corruption is discovered. Unlike <code>VALIDATE BACKUPSET</code>, RMAN proceeds and reports the number of blocks that are corrupted.</p> <p><b>See Also:</b> <a href="#">datafileCopySpec</a> for details</p>
DATAFILE <a href="#">datafileSpec</a>	<p>Specifies a list of one or more data files that contain blocks requiring validation.</p> <p><b>Note:</b> You do not have to take a data file offline if you are validating it.</p> <p><b>See Also:</b> <a href="#">datafileSpec</a></p>
RECOVERY AREA	Validates recovery files created in the current and all previous fast recovery area destinations. Recovery files are full and incremental backup sets, control file autobackups, archived redo log files, and data file copies. Flashback logs, the current control file, and online redo logs are not validated.
DB_RECOVERY_FILE_DEST	Semantically equivalent to <code>RECOVERY AREA</code> .
RECOVERY FILES	Validates <i>all</i> recovery files on disk, whether they are stored in the fast recovery area or other locations on disk. Recovery files include full and incremental backup sets, control file autobackups, archived redo log files, and data file copies. Flashback logs are not validated.
SPFILE	Validates the server parameter file currently used by the database. RMAN cannot validate other copies of the server parameter file, and cannot validate the server parameter file when the instance was started with an initialization parameter file.

Syntax Element	Description
TABLESPACE <i>tablespace_name</i>	<p>Validates the specified tablespaces. RMAN translates tablespace names internally into a list of data files, then validates all data files that are currently part of the tablespaces. RMAN validates all data files that are currently members of the specified tablespaces.</p> <p>When connected to the root in a CDB, refers to tablespaces in the root. Refers to tablespaces in a PDB when connected directly to a PDB.</p>

### ***validateOperand***

This subclause specifies modifiers for the validation. Refer to [validateOperand::=](#) for syntax.

Syntax Element	Description
CHECK LOGICAL	<p>Tests data and index blocks in the files that pass physical corruption checks for logical corruption, for example, corruption of a row piece or index entry. If RMAN finds logical corruption, then it logs the block in the alert log and server session trace file. The RMAN command completes and V\$DATABASE_BLOCK_CORRUPTION is populated with corrupt block ranges.</p> <p><b>Note:</b> VALIDATE does not use MAXCORRUPT.</p>
DEVICE TYPE <a href="#">deviceSpecifier</a>	<p>Allocates automatic channels for the specified device type only. This option is valid only if you have configured automatic channels and have not manually allocated channels. For example, if you configure automatic disk and tape channels, and run VALIDATE ...DEVICE TYPE DISK, RMAN allocates only disk channels.</p> <p><b>See Also:</b> <a href="#">deviceSpecifier</a></p>
MIRROR ALL  <i>integer</i>	<p>Validates data files on the specified mirrors.</p> <p>Use the MIRROR ALL option to validate the specified data file on all mirrors. The number of mirrors depends on the maximum number of mirrors supported by the storage system.</p> <p>Use MIRROR <i>integer</i> to validate a data file on the specified mirror. The following example validates all blocks of data file 1 in mirror 2 only:</p> <pre>VALIDATE DATAFILE 1 MIRROR 2;</pre>
NOEXCLUDE	<p>When specified on a VALIDATE DATABASE or VALIDATE COPY OF DATABASE command, RMAN validates all tablespaces, including any for which a CONFIGURE EXCLUDE command has been entered. This option does not override SKIP OFFLINE or SKIP READONLY.</p>

Syntax Element	Description
NONLOGGED BLOCK	<p>Checks whether the entries in <code>V\$NONLOGGED_BLOCK</code> correspond to the current incarnation of the file to which they belong. If they do not, then the ranges are removed and the entire file is scanned to identify the actual ranges. Otherwise RMAN just scans the blocks identified by the existing <code>V\$NONLOGGED_BLOCK</code> entries to confirm if they are still invalid and makes required adjustments.</p> <p>This clause can be used only for a primary database that is mounted or a physical standby database that is mounted or open read-only. Because validation does not correct the object number associated with the entries in <code>V\$NONLOGGED_BLOCK</code>, standby databases may report nonlogged blocks for objects that have been dropped even after running the <code>VALIDATE</code> command.</p> <p>The results of the validation are displayed in the RMAN output and also stored in the <code>V\$NONLOGGED_BLOCK</code> view. The details include the data file number validated, the number of nonlogged blocks remaining after the validation, number of blocks skipped, and the status of the validation operation. The trace file contains additional information about any validation failures.</p>
SECTION SIZE <i>sizeSpec</i>	<p>Parallelizes the validation by dividing each file into the specified section size.</p> <p>Only specify this parameter when multiple channels are configured or allocated and you want the channels to parallelize the validation, so that multiple channels can validate a single data file. This parameter applies only when validating data files.</p> <p>If you specify a section size that is larger than the size of the file, then RMAN does not parallelize validation for the file. If you specify a small section size that would produce more than 256 sections, then RMAN increases the section size to a value that results in exactly 256 sections.</p> <p><b>See Also:</b> <a href="#">BACKUP SECTION SIZE</a> to learn how to make multisection backups</p>
skipSpec	Excludes the specified files from the validation.
FROM COPY NUMBER <i>integer</i>	Specifies a copy number of the backup piece that will be validated. If the backup was duplexed, then the copy number value ranges from 2 to 4. If no duplexing was performed, then the copy number is 1.

### ***skipSpec***

This subclause specifies files to be excluded from the validation.

Syntax Element	Description
SKIP	Excludes data files or archived redo log files if they are inaccessible, offline, or read-only.
INACCESSIBLE	<p>Excludes data files and archived redo log files that cannot be read due to I/O errors.</p> <p>A data file is only considered inaccessible if it cannot be read. Some offline data files can still be read because they still exist on disk. Others have been deleted or moved and so cannot be read, making them inaccessible.</p>
OFFLINE	Excludes offline data files.
READONLY	Excludes read-only data files.

**VALIDATE Command Output****Table 3-11 List of Data Files**

Column	Indicates
File	Absolute number of the data file being validated.
Status	OK if no corruption, or FAILED if block corruption is found.
Marked Corrupt	Number of blocks marked corrupt. These blocks were previously marked corrupt by the database. For example, the database may intentionally mark blocks corrupt during a recovery involving a NOLOGGING operation. Also, an RMAN backup may contain corrupt blocks permitted by the SET MAXCORRUPT command. When this backup is restored, the file contains blocks that are marked corrupt.
Empty Blocks	Number of blocks that either have never been used.
Blocks Examined	Total number of blocks in the file.
High SCN	The highest SCN recorded in the file.
File Name	The name of the file being validated.
Block Type	The type of block validated: Data, Index, or Other.
Blocks Failing	The number of blocks that fail the corruption check. These blocks are newly corrupt.
Blocks Processed	The number of blocks checked for corruption.

**Table 3-12 List of Control File and SPFILE**

Column	Indicates
File TYPE	Type of file: SPFILE or Control File.
Status	OK if no corruption, or FAILED if block corruption is found.
Blocks Failing	The number of blocks that fail the corruption check. These blocks are newly corrupt.
Blocks Examined	Total number of blocks in the file.

**Table 3-13 List of Archived Logs**

Column	Indicates
Thrd	The redo thread number.
Seq	The log sequence number.
Status	OK if no corruption, or FAILED if block corruption is found.
Blocks Failing	The number of blocks that fail the corruption check. These blocks are newly corrupt.
Blocks Examined	Total number of blocks in the file.
Name	The name of the archived redo log file.

## Examples

### Example 3-85 Validating a Backup Set

This example lists all available backup sets and then validates them. As the sample output indicates, RMAN confirms that it is possible to restore the backups.

```

RMAN> LIST BACKUP SUMMARY;

List of Backups
=====
Key       TY LV S Device Type Completion Time #Pieces #Copies Compressed Tag
-----
3871     B F A DISK      08-MAR-13      1       1       NO      TAG20130308T092426
3890     B F A DISK      08-MAR-13      1       1       NO      TAG20130308T092534

RMAN> VALIDATE BACKUPSET 3871, 3890;

Starting validate at 08-MAR-13
using channel ORA_DISK_1
channel ORA_DISK_1: starting validation of datafile backup set
channel ORA_DISK_1: reading from backup piece
/disk2/PROD/backupset/2013_03_08/o1_mf_nnndf_TAG20130308T092 426_2z0kpc72_.bkp
channel ORA_DISK_1: piece
handle=/disk2/PROD/backupset/2013_03_08/o1_mf_nnndf_TAG20130308T092426_2z0kpc72_.bkp ta
g=TAG20130308T092426
channel ORA_DISK_1: restored backup piece 1
channel ORA_DISK_1: validation complete, elapsed time: 00:00:18
channel ORA_DISK_1: starting validation of datafile backup set
channel ORA_DISK_1: reading from backup piece
/disk2/PROD/autobackup/2013_03_08/o1_mf_s_616670734_2z0krhjv_.bkp
channel ORA_DISK_1: piece
handle=/disk2/PROD/autobackup/2013_03_08/o1_mf_s_616670734_2z0krhjv_.bkp
tag=TAG20130308T092534
channel ORA_DISK_1: restored backup piece 1
channel ORA_DISK_1: validation complete, elapsed time: 00:00:00
Finished validate at 08-MAR-13

```

### Example 3-86 Validating the Database

This example validates the database and includes sample output. The validation finds one corrupt block in data file 1. The VALIDATE output indicates that more information about the corruption can be found in the specified trace file.

```

RMAN> VALIDATE DATABASE;

Starting validate at 26-FEB-13
using channel ORA_DISK_1
channel ORA_DISK_1: starting validation of datafile
channel ORA_DISK_1: specifying datafile(s) for validation
input datafile file number=00001 name=/disk1/oradata/prod/system01.dbf
input datafile file number=00002 name=/disk1/oradata/prod/sysaux01.dbf
input datafile file number=00003 name=/disk1/oradata/prod/undotbs01.dbf
input datafile file number=00004 name=/disk1/oradata/prod/cwmlite01.dbf
input datafile file number=00005 name=/disk1/oradata/prod/drsys01.dbf
input datafile file number=00006 name=/disk1/oradata/prod/example01.dbf
input datafile file number=00007 name=/disk1/oradata/prod/indx01.dbf
input datafile file number=00008 name=/disk1/oradata/prod/tools01.dbf
input datafile file number=00009 name=/disk1/oradata/prod/users01.dbf
channel ORA_DISK_1: validation complete, elapsed time: 00:01:25
List of Datafiles
=====
File Status Marked Corrupt Empty Blocks Blocks Examined High SCN
-----
1    FAILED 0          4140      57600      498288
   File Name: /disk1/oradata/prod/system01.dbf

```

```

Block Type Blocks Failing Blocks Processed
-----
Data      1          41508
Index     0          7653
Other     0          4299

File Status Marked Corrupt Empty Blocks Blocks Examined High SCN
-----
2  OK      0          8918          20040          498237
  File Name: /disk1/oradata/prod/sysaux01.dbf
  Block Type Blocks Failing Blocks Processed
  -----
  Data      0          2473
  Index     0          2178
  Other     0          6471

File Status Marked Corrupt Empty Blocks Blocks Examined High SCN
-----
3  OK      0          36           2560          498293
  File Name: /disk1/oradata/prod/undotbs01.dbf
  Block Type Blocks Failing Blocks Processed
  -----
  Data      0          0
  Index     0          0
  Other     0          2524

File Status Marked Corrupt Empty Blocks Blocks Examined High SCN
-----
4  OK      0          1           1280          393585
  File Name: /disk1/oradata/prod/cwmlite01.dbf
  Block Type Blocks Failing Blocks Processed
  -----
  Data      0          0
  Index     0          0
  Other     0          1279

File Status Marked Corrupt Empty Blocks Blocks Examined High SCN
-----
5  OK      0          1           1280          393644
  File Name: /disk1/oradata/prod/drsys01.dbf
  Block Type Blocks Failing Blocks Processed
  -----
  Data      0          0
  Index     0          0
  Other     0          1279

File Status Marked Corrupt Empty Blocks Blocks Examined High SCN
-----
6  OK      0          1           1280          393690
  File Name: /disk1/oradata/prod/example01.dbf
  Block Type Blocks Failing Blocks Processed
  -----
  Data      0          0
  Index     0          0
  Other     0          1279

File Status Marked Corrupt Empty Blocks Blocks Examined High SCN
-----
7  OK      0          1           1280          393722
  File Name: /disk1/oradata/prod/indx01.dbf
  Block Type Blocks Failing Blocks Processed
  -----
  Data      0          0
  Index     0          0
  Other     0          1279

File Status Marked Corrupt Empty Blocks Blocks Examined High SCN
-----
8  OK      0          1           1280          393754

```



```
File Name: /disk1/oradata/prod/tools01.dbf
Block Type Blocks Failing Blocks Processed
-----
Data      0          0
Index     0          0
Other     0         1279
```

```
File Status Marked Corrupt Empty Blocks Blocks Examined High SCN
-----
9  OK      0          1272      1280          393785
  File Name: /disk1/oradata/prod/users01.dbf
  Block Type Blocks Failing Blocks Processed
  -----
  Data      0          0
  Index     0          0
  Other     0          8
```

validate found one or more corrupt blocks

See trace file /disk2/oracle/log/diag/rdbms/prod/prod/trace/prod\_ora\_10609.trc for details

channel ORA\_DISK\_1: starting validation of datafile

channel ORA\_DISK\_1: specifying datafile(s) for validation

including current control file for validation

including current SPFILE in backup set

channel ORA\_DISK\_1: validation complete, elapsed time: 00:00:01

List of Control File and SPFILE

```
=====
File Type      Status Blocks Failing Blocks Examined
-----
SPFILE        OK      0          2
Control File OK      0         506
Finished validate at 26-FEB-13
```

# 4

## RMAN Subclauses

This chapter describes, in alphabetical order, Recovery Manager subclauses referred to within RMAN commands. For a summary of the RMAN subclauses, refer to "[Summary of RMAN Subclauses](#)".

- [allocOperandList](#)
- [archivelogRecordSpecifier](#)
- [completedTimeSpec](#)
- [connectStringSpec](#)
- [datafileSpec](#)
- [dbObject](#)
- [deviceSpecifier](#)
- [fileNameConversionSpec](#)
- [forDbUniqueNameOption](#)
- [foreignFileSpec](#)
- [foreignlogRecordSpecifier](#)
- [formatSpec](#)
- [keepOption](#)
- [listObjList](#)
- [maintQualifier](#)
- [maintSpec](#)
- [obsOperandList](#)
- [recordSpec](#)
- [sizeSpec](#)
- [tempfileSpec](#)
- [toDestSpec](#)
- [untilClause](#)



### Note:

A multitenant container database is the only supported architecture in Oracle Database 21c. While the documentation is being revised, legacy terminology may persist. In most cases, "database" and "non-CDB" refer to a CDB or PDB, depending on context. In some contexts, such as upgrades, "non-CDB" refers to a non-CDB from a previous release.

## 4.1 allocOperandList

### Purpose

Use the *allocOperandList* subclause to control options on a **channel**, which is a connection between RMAN and a database instance.

### Syntax

**allocOperandList::=**

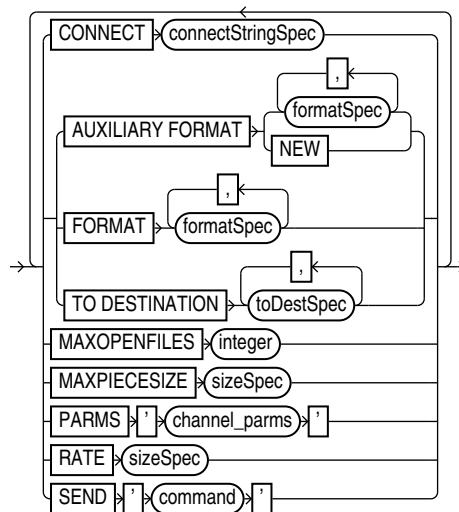

([connectStringSpec::=](#), [formatSpec::=](#), [sizeSpec::=](#), [toDestSpec::=](#))

### Semantics

**allocOperandList**

Syntax Element	Description
CONNECT <a href="#">connectStringSpec</a>	<p>Specifies a connect string to the database instance where RMAN conducts the backup or restore operations. Use this parameter to spread the work across different instances in an Oracle RAC configuration.</p> <p>If you do not specify this parameter, and if you did not specify the <code>AUXILIARY</code> option, then RMAN conducts all operations on the target database instance specified by the command-line <code>CONNECT</code> parameter or <code>CONNECT</code> command. Typically, do not use the <code>CONNECT</code> parameter with the <code>AUXILIARY</code> option.</p> <p><b>See Also:</b> <a href="#">connectStringSpec</a> and <a href="#">RMAN</a></p>
AUXILIARY FORMAT	<p>Specifies the format of image copies created on an auxiliary instance. RMAN must be connected to the auxiliary instance with <code>CONNECT AUXILIARY</code> and have access to auxiliary channels.</p>
<a href="#">formatSpec</a>	<p>Specifies a pattern for image copy names on an auxiliary instance. The path must be valid on the auxiliary host.</p> <p><b>See Also:</b> <a href="#">formatSpec</a> for valid substitution variables</p>

Syntax Element	Description
NEW	<p>Creates an image copy in the directory specified by the <code>DB_CREATE_FILE_DEST</code> initialization parameter of the auxiliary instance.</p> <p>The image copy name is in an Oracle Managed Files format.</p>
FORMAT <a href="#">formatSpec</a>	<p>Specifies the format to use for the names backup pieces or image copies created on this channel. <a href="#">Example 4-1</a> illustrates this technique.</p> <p>The <code>FORMAT</code> parameter is useful if you allocate multiple disk channels and want each channel to write to a different directory. The <code>FORMAT</code> parameter specified in <a href="#">CONFIGURE CHANNEL</a> or <a href="#">ALLOCATE CHANNEL</a> is semantically equivalent to the <code>FORMAT</code> parameter specified in the <code>BACKUP</code> command (not the <code>DATAFILECOPY</code> <code>FORMAT</code> parameter in <a href="#">forRecoveryOfSpec</a>). If you specify the <code>FORMAT</code> parameter in the <code>BACKUP</code> command, then it overrides the <code>FORMAT</code> parameter specified in <a href="#">CONFIGURE CHANNEL</a> or <a href="#">ALLOCATE CHANNEL</a>.</p> <p>If you do not specify <code>FORMAT</code>, then RMAN uses <code>%U</code> by default, which guarantees a unique name for the names of the backup files. If the fast recovery area is configured, then RMAN creates the backup files in the default disk location. Otherwise, the default disk location is operating system-specific (for example, <code>*/dbs</code> on Solaris).</p> <p>You can specify up to four <code>FORMAT</code> strings. RMAN uses the second, third, and fourth values only when <code>BACKUP COPIES</code>, <code>SET BACKUP COPIES</code>, or <code>CONFIGURE ... BACKUP COPIES</code> is in effect. When choosing which format to use for each backup piece, RMAN uses the first format value for copy 1, the second format value for copy 2, and so forth. If the number of format values exceeds the number of copies, then the extra formats are not used. If the number of format values is less than the number of copies, then RMAN reuses the format values, starting with the first one.</p> <p>Because the channels correspond to server sessions on the target database, the <code>FORMAT</code> string must use the conventions of the target host, not the client host. For example, if the RMAN client runs on a Windows host and the target database runs on a Linux host, then the <code>FORMAT</code> string must adhere to the naming conventions of a Linux file system or raw device.</p> <p><b>See Also:</b> <a href="#">formatSpec</a> for available <code>FORMAT</code> parameters</p>
TO DESTINATION <a href="#">toDestSpec</a>	<p>Specifies the directory where the backup is created. This parameter is valid for disk and not SBT channels. The backup files are created in an Oracle Managed Files (OMF) directory. Backup skips the files only when backups do not exist in the specified <code>TO DESTINATION</code>.</p>
MAXOPENFILES <i>integer</i>	<p>Controls the maximum number of input files that a <code>BACKUP</code> command can have open at any given time (the default is 8). Use this parameter to prevent "Too many open files" error messages when backing up a large number of files into a single backup set.</p>
MAXPIECESIZE <a href="#">sizeSpec</a>	<p>Specifies the maximum size of each backup piece created on this channel. <a href="#">Example 4-2</a> illustrates this technique. Specify the size in bytes, kilobytes (K), megabytes (M), or gigabytes (G). The default setting is in bytes and is rounded down into kilobytes. For example, if you set <code>MAXPIECESIZE</code> to 5000, RMAN sets the maximum piece size at 4 kilobytes, which is the lower kilobyte boundary of 5000 bytes.</p> <p><b>Note:</b> You cannot use <code>BACKUP ... SECTION SIZE</code> with <code>MAXPIECESIZE</code>.</p>

Syntax Element	Description
PARMS 'channel_parms'	<p>Specifies parameters for the <code>sbt</code> channel. <a href="#">Example 4-3</a> illustrates this technique. Do not use this port-specific string if you have specified <code>DEVICE TYPE DISK</code>.</p> <p>You can use the following formats for the channel parameters:</p> <ul style="list-style-type: none"> <li>'ENV=(var1=val1, var2=val2,...)'</li> </ul> <p>Specifies one or more environment variables required by the media manager in the server session corresponding to this RMAN client. Because RMAN is a client program, you can use the <code>ENV</code> parameter to set server session-specific variables that perform operations on behalf of the RMAN client, for example, <code>PARMS 'ENV=(OB_DEVICE_1=tape1)'</code>.</p> <ul style="list-style-type: none"> <li>'SBT_LIBRARY=lib_name'</li> </ul> <p>In cases where the media management library supports it, (for example, the OSB Cloud Module) you must use the <code>SBT_PARMS</code> parameter to specify environment variables. In all other scenarios, you use the <code>ENV</code> variable.</p> <p>Specifies which media library is used on this <code>sbt</code> channel, for example, <code>PARMS="SBT_LIBRARY=/oracle/lib/mmvs.so"</code>. The default library is operating system-specific (for example, <code>libobk.so</code> on Linux and <code>ORASBT.DLL</code> on Windows).</p> <p>On Windows, parameters set using <code>ENV</code> are visible to all the channels. This may cause indeterministic behavior if a channel clears or overrides an environment variable that is being used by another channel. This restriction is caused by the Oracle architecture on Windows. It is recommended that you use the <code>SEND</code> command to set environment variables for the SBT library, instead of using <code>ENV</code> in the <code>PARAMS</code> option.</p> <p><b>See Also:</b> <i>Oracle Database Backup and Recovery User's Guide</i> to learn how to integrate media management libraries</p>
RATE <a href="#">sizeSpec</a>	<p>Sets the maximum number of bytes (default), kilobytes (K), megabytes (M), or gigabytes (G) that RMAN reads each second on this channel. This parameter sets an upper limit for bytes read so that RMAN does not consume too much disk bandwidth and degrade performance.</p>
SEND 'command'	<p>Sends a vendor-specific command string to all allocated channels. For example, you could specify an Oracle Secure Backup media family with <code>SEND 'OB_MEDIA_FAMILY datafile_mf'</code>.</p> <p>On Windows, to send command strings to the SBT library, it is recommended that you use the <code>SEND</code> option instead of using <code>ENV</code> in the <code>PARAMS</code> option.</p> <p><b>See Also:</b> Your media manager documentation to determine whether this feature is supported and when to use it.</p>

### **toDestSpec**

This subclause specifies either a directory or an Automated Storage Management (ASM) disk group for a backup piece or image copy. Refer to [toDestSpec::=](#) for the syntax diagram.

### **Examples**

#### **Example 4-1 Specifying the Default Location for Disk Backups**

This example allocates a disk channel that specifies a nondefault format, and then backs up the database to the nondefault location.

```
RUN
{
```

```

ALLOCATE CHANNEL d1 DEVICE TYPE DISK FORMAT = '/disk1/bkup_%U';
BACKUP DATABASE;
}

```

### Example 4-2 Setting the Maximum Size of a Backup Piece

This example manually allocates an SBT channel, which specifies an Oracle Secure Backup tape drive, and makes a whole database backup. The `MAXPIECESIZE` parameter specifies that no backup piece written to tape can exceed 800 MB.

```

RUN
{
  ALLOCATE CHANNEL c1 DEVICE TYPE sbt
    PARMS 'SBT_LIBRARY=/usr/local/oracle/backup/lib/libobk.so,
ENV=(OB_DEVICE_1=stape1)'
    MAXPIECESIZE 800M;
  BACKUP DATABASE;
}

```

### Example 4-3 Setting SBT Channel Parameters

This example configures the default SBT channel to use the Oracle Secure Backup tape drive named `stape1` and makes a database backup with the default channel:

```

CONFIGURE DEFAULT DEVICE TYPE TO sbt;
CONFIGURE CHANNEL DEVICE TYPE sbt PARMS 'ENV=(OB_DEVICE_1=stape1)';
BACKUP DATABASE;

```

Later you decide to back up the database to drive `stape2`. The following examples uses a manually allocated SBT channel to back up the database to `stape2`.

```

RUN
{
  ALLOCATE CHANNEL st2 DEVICE TYPE sbt
    PARMS 'ENV=(OB_DEVICE_1=stape2)';
  BACKUP DATABASE;
}

```

## 4.2 archivelogRecordSpecifier

### Purpose

Use the *archivelogRecordSpecifier* subclause to specify a set of archived redo log files for use in RMAN operations.

### Syntax

**archivelogRecordSpecifier::=**

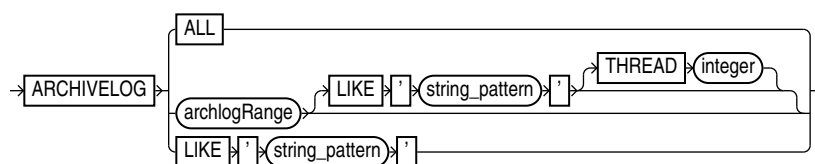

**archlogRange::=**

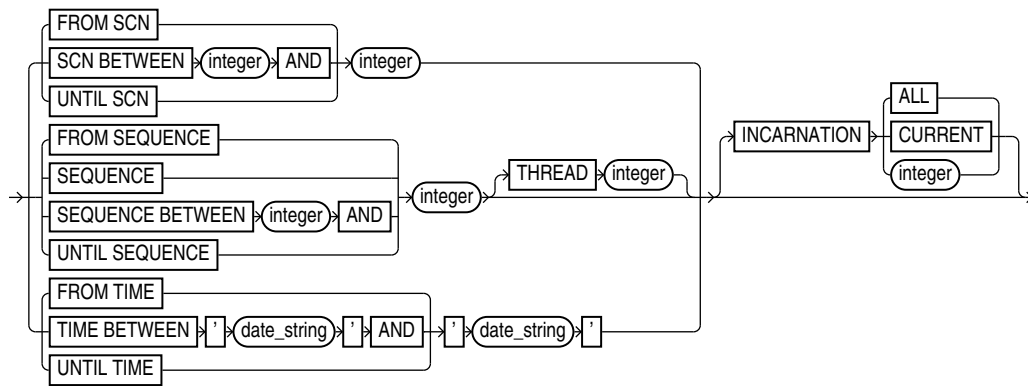

## Semantics

### *archivelogRecordSpecifier*

This subclause specifies either all archived redo log files or logs with file names that match a specified pattern.

Syntax Element	Description
ALL	Specifies all available archived logs.
LIKE ' <i>string_pattern</i> '	Specifies all archived logs that match the specified <i>string_pattern</i> . You can use the same pattern matching characters that are valid in the LIKE operator in the SQL language to match multiple files. <b>See Also:</b> <i>Oracle Real Application Clusters Administration and Deployment Guide</i> to learn about using RMAN in an Oracle RAC configuration

### *archlogRange*

This subclause specifies a range of archived redo log files by SCN, time, restore point (which is a label for a timestamp or SCN), or log sequence number. This subclause is useful for identifying the point to which you want the database to be recoverable.

RMAN queries the `V$ARCHIVED_LOG` or `RC_ARCHIVED_LOG` view to determine which logs to include in the range. When you specify a time, SCN, or restore point, RMAN determines the range according to the contents of the archived redo log files, not when the logs were created or backed up. When you specify the range by log sequence number, then RMAN uses the sequence number to determine the range.

[Table 4-1](#) explains how RMAN determines which logs are in the range. The columns `FIRST_TIME`, `NEXT_TIME`, and so on refer to columns in `V$ARCHIVED_LOG`. Additionally, the column `INCARNATION` corresponds to the incarnation column in the `v$database_incarnation` table which is joined with `v$archived_log` on the `resetlogs_change#` and `resetlogs_time` columns.

For example, if you specify `FROM SCN 1000 UNTIL SCN 2000`, then RMAN includes all logs whose `V$ARCHIVED_LOG.NEXT_SCN` value is greater than 1000 and whose `V$ARCHIVED_LOG.FIRST_SCN` value is less than or equal to 2000.

Table 4-1 Determining Logs for Inclusion in the Range

Subclause	FIRST_TIME	NEXT_TIME	FIRST_SCN	NEXT_SCN	SEQUENCE #	INCARNATION#
FROM TIME t1	n/a	Later than t1	n/a	n/a	n/a	n/a
FROM TIME t1 UNTIL TIME t2	Earlier than or equal to t2	Later than t1	n/a	n/a	n/a	n/a
UNTIL TIME t2	Earlier than or equal to t2	n/a	n/a	n/a	n/a	n/a
FROM SCN s1	n/a	n/a	n/a	Greater than s1	n/a	n/a
FROM SCN s1 UNTIL SCN s2	n/a	n/a	Less than or equal to s2	Greater than s1	n/a	n/a
UNTIL SCN s2	n/a	n/a	Less than or equal to s2	n/a	n/a	n/a
FROM SEQUENCE q1	n/a	n/a	n/a	n/a	Between q1 and the maximum sequence (inclusive)	n/a
FROM SEQUENCE q1 UNTIL SEQUENCE q2	n/a	n/a	n/a	n/a	Between q1 and q2 (inclusive)	n/a
UNTIL SEQUENCE q2	n/a	n/a	n/a	n/a	Between 0 and q2 (inclusive)	n/a
INCARNATION ALL	n/a	n/a	n/a	n/a	n/a	ANY
INCARNATION CURRENT	n/a	n/a	n/a	n/a	n/a	Active incarnation number
INCARNATION i	n/a	n/a	n/a	n/a	n/a	Equals i

The time must be formatted according to the Globalization Technology date format specification currently in effect. If your current Globalization settings do not specify the time, then string dates default to 00 hours, 00 minutes, and 00 seconds.

The *date\_string* can be any SQL expression of type DATE, such as SYSDATE. You can use TO\_DATE to specify hard-coded dates that work regardless of the current Globalization Technology settings. SYSDATE always has seconds precision regardless of the Globalization settings. Thus, if today is March 15, 2013, then SYSDATE-10 is not equivalent to 05-MAR-13 or TO\_DATE('03/15/2013', 'MM/DD/YYYY')-10.

Specifying a sequence of archived redo log files does not guarantee that RMAN includes all redo data in the sequence. For example, the last available archived log file may end before the end of the sequence, or an archived log file in the range may be missing from all archiving destinations. RMAN includes the archived redo log files it finds and does not issue a warning for missing files.



 **Note:**

If the database is open when you run `BACKUP ARCHIVELOG`, and if the `UNTIL` clause is specified, then RMAN does not run `ALTER SYSTEM ARCHIVE LOG CURRENT`.

 **See Also:**

*Oracle Database Reference* to learn how to use the `NLS_LANGUAGE` and `NLS_DATE_FORMAT` environment variables to specify time format

Syntax Element	Description
<code>FROM SCN integer</code>	Specifies the beginning SCN for a range of archived redo log files. If you do not specify the <code>UNTIL SCN</code> parameter, then RMAN includes all available log files beginning with SCN specified in the <code>FROM SCN</code> parameter.
<code>SCN BETWEEN integer AND integer</code>	Specifies the beginning and ending SCN for a range of logs. This syntax is semantically equivalent to <code>FROM SCN integer1 UNTIL SCN integer2</code> .
<code>UNTIL SCN integer</code>	Specifies the ending SCN for a range of archived redo log files (see <a href="#">Table 4-1</a> for the rules determining the range).
<code>FROM SEQUENCE integer</code>	Specifies the beginning log sequence number for a sequence of archived redo log files (see <a href="#">Table 4-1</a> for the rules determining the range). <b>Note:</b> You can specify all log sequence numbers in a thread by using the syntax shown in <a href="#">Example 4-6</a> .
<code>SEQUENCE integer</code>	Specifies a single log sequence number.
<code>SEQUENCE BETWEEN integer AND integer</code>	Specifies a range of log sequence numbers. This syntax is semantically equivalent to <code>FROM SEQUENCE integer1 UNTIL SEQUENCE integer2</code> .
<code>UNTIL SEQUENCE integer</code>	Specifies the terminating log sequence number for a sequence of archived redo log files (see <a href="#">Table 4-1</a> for the rules determining the range).
<code>THREAD integer</code>	Specifies the thread containing the archived redo log files you want to include. This parameter is only necessary if the database is in an Oracle RAC configuration. Although the <code>SEQUENCE</code> parameter does not require that <code>THREAD</code> be specified, a given log sequence always implies a thread. The thread defaults to 1 if not specified. Query <code>V\$ARCHIVED_LOG</code> to determine the thread number for a log.
<code>INCARNATION ALL CURRENT  integer</code>	Specifies the database incarnation for archived redo logs for the <code>BACKUP</code> , <code>RESTORE</code> and <code>LIST</code> commands. <code>INCARNATION</code> enables you to designate either current archive redo logs, archive redo logs from a previous incarnation of the database or all redo logs. <code>CURRENT</code> is the default. <b>Note:</b> The <code>INCARNATION</code> subclause is not valid for foreign archived redo log files that are received by a logical standby database for a LogMiner session. Unlike normal archived redo log files, foreign archived redo log files have a different <code>DBID</code> and cannot be backed up or restored on a logical standby database.
<code>FROM TIME 'date_string'</code>	Specifies the beginning time for a range of archived redo log files (see <a href="#">Table 4-1</a> for the rules determining the range). <a href="#">Example 4-5</a> shows <code>FROM TIME</code> in a <code>LIST</code> command.

Syntax Element	Description
TIME BETWEEN 'date_string' AND 'date_string'	Specifies a range of times. This syntax is semantically equivalent to FROM TIME 'date_string' UNTIL TIME 'date_string'.
UNTIL TIME 'date_string'	Specifies the end time for a range of archived redo log files (see <a href="#">Table 4-1</a> for the rules determining the range). <a href="#">Example 4-4</a> shows UNTIL TIME in a BACKUP command.

## Examples

### Example 4-4 Specifying Records by Recovery Point-in-Time

Assume that you want to be able to recover the database to a point in time 5 days before now. You want to back up a range of archived redo log files that makes this point-in-time recovery possible.

You can use the UNTIL TIME 'SYSDATE-5' clause to specify that all logs in the range have a first time (shown by V\$ARCHIVED\_LOG.FIRST\_TIME) that is earlier than or equal to SYSDATE-5. This function resolves to a time with seconds precision five days before now.

```
CONNECT TARGET /
BACKUP ARCHIVELOG UNTIL TIME 'SYSDATE-5';
```

### Example 4-5 Listing Archived Log Backups by Time

As shown in [Table 4-1](#), when you specify *date\_string* for a range of archived redo log files, you are not specifying the backup time or creation time of the log. Assume that archived log 32 has a next time of March 6.

```
SQL> SELECT SEQUENCE#, NEXT_TIME
       2 FROM V$ARCHIVED_LOG
       3 WHERE SEQUENCE#='32';
```

```
SEQUENCE# NEXT_TIME
-----
50 06-MAR-13
```

On March 8 you run the following BACKUP and LIST commands:

```
RMAN> BACKUP ARCHIVELOG SEQUENCE 32;
```

```
Starting backup at 08-MAR-13
allocated channel: ORA_SBT_TAPE_1
channel ORA_SBT_TAPE_1: SID=109 device type=SBT_TAPE
channel ORA_SBT_TAPE_1: Oracle Secure Backup
channel ORA_SBT_TAPE_1: starting archived log backup set
channel ORA_SBT_TAPE_1: specifying archived log(s) in backup set
input archived log thread=1 sequence=32 RECID=125 STAMP=616528547
channel ORA_SBT_TAPE_1: starting piece 1 at 08-MAR-13
channel ORA_SBT_TAPE_1: finished piece 1 at 08-MAR-13
piece handle=6kic3fkm_1_1 tag=TAG20130308T111014 comment=API Version 2.0,MMS
Version 10.1.0.3
```

```
channel ORA_SBT_TAPE_1: backup set complete, elapsed time: 00:00:25
Finished backup at 08-MAR-13
```

```
Starting Control File and SPFILE Autobackup at 08-MAR-13
piece handle=c-28014364-20130308-08 comment=API Version 2.0,MMS
Version 10.1.0.3
Finished Control File and SPFILE Autobackup at 08-MAR-13
```

```
RMAN> LIST BACKUP OF ARCHIVELOG FROM TIME 'SYSDATE-1';
```

Because the next time of log 32 is earlier than the range of times specified in the `FROM TIME` clause, the preceding `LIST BACKUP` command does not show the backup of archived log 32.

#### Example 4-6 Crosschecking All Logs in a Redo Thread

Assume that you are managing an Oracle RAC database with two threads of redo. This example crosschecks all archived redo log files in thread 1 only.

```
CROSSCHECK ARCHIVELOG FROM SEQUENCE 0 THREAD 1;
```

## 4.3 completedTimeSpec

### Purpose

Use the *completedTimeSpec* subclause to specify when a backup or copy completed.

### Usage Notes

All date strings must be either:

- Formatted according to the Global Technology date format specification currently in effect.
- Created by a SQL expression that returns a `DATE` value, as in the following examples:

```
– 'SYSDATE-30'
– TO_DATE('09/30/2013 08:00:00', 'MM/DD/YYYY HH24:MI:SS')
```

The `TO_DATE` function specifies dates independently of the current Global Technology environment variable settings.

### Syntax

***completedTimeSpec*::=**

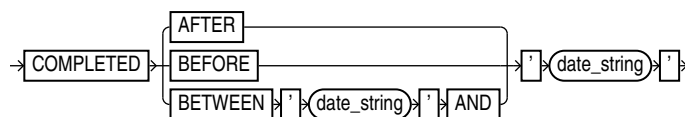

## Semantics

Syntax Element	Description
AFTER 'date_string'	Specifies the time after which the backup was completed (see <a href="#">Example 4-7</a> ).
BEFORE 'date_string'	Specifies the time before which the backup was completed (see <a href="#">Example 4-9</a> ).
BETWEEN 'date_string' AND 'date_string'	Specifies a time range during which the backup was completed (see <a href="#">Example 4-8</a> ). BETWEEN 'date1' AND 'date2' equals AFTER 'date1' BEFORE 'date2'.

## Examples

### Example 4-7 Crosschecking Backups Within a Time Range

This example crosschecks the backup sets of the database made last month:

```
CROSSCHECK BACKUP OF DATABASE
  COMPLETED BETWEEN 'SYSDATE-62' AND 'SYSDATE-31';
```

### Example 4-8 Deleting Expired Backups

This example deletes expired backups of archived logs made in the last two weeks:

```
DELETE EXPIRED BACKUP OF ARCHIVELOG ALL
  COMPLETED AFTER 'SYSDATE-14';
```

### Example 4-9 Listing Copies

This example lists image copies of data file /disk1/oradata/prod/users01.dbf made before March 9, 2013:

```
RMAN> LIST COPY OF DATAFILE '/disk1/oradata/prod/users01.dbf' COMPLETED BEFORE '9-
MAR-13';
```

List of Datafile Copies

=====

Key	File S	Completion Time	Ckp SCN	Ckp Time
3794	28 A	06-MAR-13	1010097	06-MAR-13
	Name: /disk1/oradata/prod/users01.dbf			
3793	28 A	06-MAR-13	1009950	06-MAR-13
	Name: /disk2/PROD/datafile/o1_mf_users_2yvg4v6o_.dbf			
	Tag: TAG20130306T105314			

## 4.4 connectStringSpec

### Purpose

Use the *connectStringSpec* subclause to specify the user name, password, and net service name for connecting to a target, recovery catalog, or auxiliary database. The connection is necessary to authenticate the user and identify the database.

### Prerequisites

You must have SYSBACKUP or SYSDBA privilege to **CONNECT** to a target or auxiliary database.

Do not connect to the recovery catalog database as the `SYS` user or a user with the `SYSDBA` or `SYSBACKUP` privilege.

### Usage Notes

RMAN connections to a database are specified and authenticated in the same way as SQL\*Plus connections to a database. The only difference is that RMAN connections to a target or auxiliary database require the `SYSBACKUP` or `SYSDBA` privilege.

`SYSBACKUP` grants the minimum privileges needed for backup and recovery. It grants `SELECT` privileges on database catalog views and dynamic performance views, but it does not grant privileges on user tables and views, such as `SELECT ANY TABLE`. If you connect to RMAN as a privileged user (such as `OE` with the `SYSBACKUP` privilege), your user name for the session is `SYSBACKUP`. Thus, you do not have privileges on the tables and views owned by `OE` or any other user.

When you connect by specifying `AS SYSBACKUP` in the connect string, the default mode used is `SYSBACKUP`, the session user name is `SYSBACKUP`, and the default schema is `SYS`. In all other cases, the default mode `SYSDBA`, the session user name is `SYS` and the default schema is `SYS`.

#### See Also:

- *Oracle Database Administrator's Guide* to learn about database connection options when using SQL\*Plus
- *Oracle Database Backup and Recovery User's Guide* to learn about using the `SYSBACKUP` or `SYSDBA` administrative privilege

#### Caution:

Good security practice requires that passwords are not be entered in plain text on the command line. Enter passwords in RMAN only when requested by an RMAN prompt. See *Oracle Database Security Guide* to learn about password protection.

### Syntax

**connectStringSpec::=**

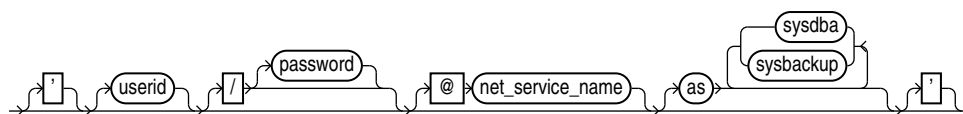

## Semantics

Syntax Element	Description
/	<p>If you do not specify a user ID or password when connecting to a target database, then a slash establishes a connection using the <code>SYSDBA</code> privilege by using operating system authentication (see <a href="#">Example 4-12</a>).</p> <p>In a multitenant container database (CDB), a connection is established with the root using the <code>SYSDBA</code> privilege.</p> <p><b>Note:</b> The slash depends on platform-specific environment variables.</p>
<code>userid</code>	<p>Establishes a connection to the database for the specified user.</p> <p>To connect to the root in a CDB, the user must be a common user with the common <code>SYSBACKUP</code> or <code>SYSDBA</code> privilege.</p> <p>To connect to a pluggable database (PDB), the user must be one of the following:</p> <ul style="list-style-type: none"> <li>• a common user with the common <code>SYSBACKUP</code> or <code>SYSDBA</code> privilege</li> <li>• a common user with <code>SYSBACKUP</code> or <code>SYSDBA</code> privilege in the specified PDB</li> <li>• a local user defined in the PDB and granted the <code>SYSBACKUP</code> or <code>SYSDBA</code> privilege</li> </ul> <p>See <i>Oracle Database Backup and Recovery User's Guide</i> for examples on connecting to CDBs and PDBs.</p> <p>Do not use a privileged account such as <code>SYSDBA</code> when connecting to a recovery catalog.</p> <p><b>Note:</b> The connect string must not contain any white space, but it can contain punctuation characters such as a slash (/) and an at sign (@).</p>
<code>/password</code>	<p>Establishes a connection for the specified user by using a password. If the target database is not open, then a password file must exist.</p> <p><b>Caution:</b> Passwords entered in plain text on the command line are a security vulnerability. Instead, omit the password from the command line and enter it in response to the prompt (see <a href="#">Example 4-11</a>).</p>
<code>@net_service_name</code>	<p>Establishes a connection to the database through an optional Oracle Net net service name (see <a href="#">Example 4-10</a>).</p>
<code>AS {SYSDBA   SYSBACKUP}</code>	<p>Invokes the administrative privileges that have been granted to / or <code>userid</code>. This clause is unnecessary for connecting with the default privileges. For tablespace point-in-time recovery (TSPITR), use the same mode as the connection to the target database. When this clause is omitted, the <code>SYSDBA</code> is used as the default.</p> <p>Do not use this clause when connecting to a recovery catalog.</p>

## Examples

**Example 4-10 Connecting to a Target Database Without a Recovery Catalog**

This example starts RMAN without specifying a database connection. The `CONNECT` command connects to a target database by using the Oracle Net service name `PROD` in the default `NOCATALOG` mode. `sbu` is a user who is granted the `SYSBACKUP` privilege. The `sbu` password is entered in response to a prompt.

```
% rman
RMAN> CONNECT TARGET "sbu@prod AS SYSBACKUP"

target database Password: password
connected to target database: PROD (DBID=39525561)
```

### Example 4-11 Connecting to a Target Database at the Operating System Command Line

This example connects to the target database as user `SBU` at the operating system command line, but without specifying a password. RMAN prompts for the password.

```
% rman TARGET SBU

Recovery Manager: Release 12.1.0.1.0 - Production on Fri Jan 11 09:15:53 2013

Copyright (c) 1982, 2013, Oracle and/or its affiliates. All rights reserved.

target database Password: password
```

### Example 4-12 Connecting to a Target Database with Operating System Authentication

This example starts RMAN and then connects to the target database `PROD` using operating system authentication. The example also connects to the recovery catalog database `CATDB` using a net service name.

```
% rman
RMAN> CONNECT TARGET /

connected to target database: PROD (DBID=39525561)

RMAN> CONNECT CATALOG rco@catdb

recovery catalog database Password: password
connected to recovery catalog database
```

## 4.5 datafileSpec

### Purpose

Use the *datafileSpec* subclause to specify a data file by file name or absolute file number.

### Syntax

***datafileSpec*::=**

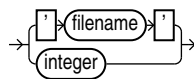

## Semantics

Syntax Element	Description
'filename'	<p>Specifies the data file by using either the full path or a relative file name. If you specify a relative file name, then the file name is qualified in a port-specific manner by the target database. You can use ? to represent the Oracle home and @ for the Oracle SID (see <a href="#">Example 4-14</a>).</p> <p>Double and single quotes are both valid (although only single quotes are shown in the diagram).</p> <p><b>See Also:</b> "<a href="#">Quotes in RMAN Syntax</a>" to learn about the difference between single and double quotes, and the behavior of environment variables in RMAN quoted strings</p>
integer	<p>Specifies the data file by using its absolute file number (see <a href="#">Example 4-13</a>). Obtain the file number from the V\$DATAFILE, V\$DATAFILE_COPY, or V\$DATAFILE_HEADER views or <a href="#">REPORT SCHEMA</a> command output.</p>

## Examples

**Example 4-13 Specifying a Data File by File Name**

This example copies data file /disk1/oradata/prod/users01.dbf to disk, specifying it by file name:

```
BACKUP AS COPY
  DATAFILE '/disk1/oradata/prod/users01.dbf'
  FORMAT '/disk2/users01.cpy';
```

**Example 4-14 Specifying a Data File by Absolute File Number**

This example copies data files 1 and 2 to disk, specifying them by file number:

```
BACKUP AS COPY
  DATAFILE 1 FORMAT '/disk2/df1.cpy'
  DATAFILE 2 FORMAT '/disk2/df1.cpy';
```

## 4.6 dbObject

**Purpose**

Use the *dbObject* subclause to identify a database or a subset of a database.

**Syntax**

**dbObject::=**



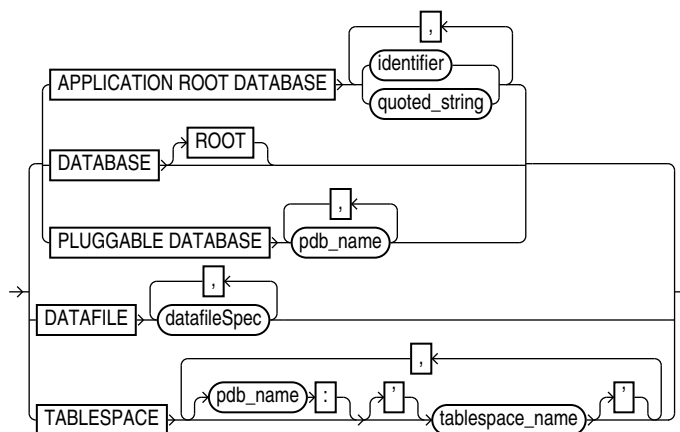

(datafileSpec::=)

### Semantics

Syntax Element	Description
DATABASE	Specifies the entire database. In a multitenant container database (CDB), specifies the whole CDB.
DATABASE ROOT	Specifies only the root in a CDB.
PLUGGABLE DATABASE <i>pdb_name</i>	Specifies one or more pluggable databases (PDBs) in a CDB. Use a comma-delimited list to specify multiple PDBs.
DATAFILE <a href="#">datafileSpec</a>	Specifies a list of one or more data files by either file name or absolute data file number. <b>See Also:</b> <a href="#">datafileSpec</a>
TABLESPACE <i>tablespace_name</i>	Specifies one or more tablespaces.
TABLESPACE <i>pdb_name:tablespace_name</i>	Specifies the name of a tablespace in a PDB. Use a comma-delimited list to specify multiple tablespaces. Multiple PDBs can have tablespaces with the same name. A qualifier before the name uniquely identifies the tablespace. <i>pdb_name</i> is the name of the PDB that contains <i>tablespace_name</i> . If <i>pdb_name</i> is omitted, root is used as the default container.

## 4.7 deviceSpecifier

### Purpose

Use the *deviceSpecifier* subclause to specify the type of storage for a backup.

### Syntax

***deviceSpecifier*::=**

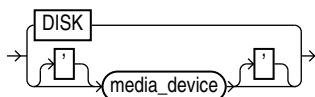

## Semantics

Syntax Element	Description
DISK	Specifies a disk storage device (see <a href="#">Example 4-16</a> ).
<i>media_device</i>	<p>Specifies a sequential I/O device or access method for storage (see <a href="#">Example 4-15</a>).</p> <p>The <i>media_device</i> variable specifies a case-insensitive name for a media manager. The syntax and semantics of sequential I/O device types are platform-specific. The most common value is <i>sbt</i> or <i>sbt_tape</i> (which are synonymous values).</p> <p><b>Note:</b> RMAN stores the value <i>sbt</i> in the recovery catalog as <i>sbt_tape</i> for backward compatibility.</p>

## Examples

### Example 4-15 Allocating a Tape Channel

This example allocates a maintenance channel for a media management device:

```
ALLOCATE CHANNEL FOR MAINTENANCE DEVICE TYPE sbt;
CROSSCHECK BACKUP;
RELEASE CHANNEL;
```

### Example 4-16 Backing Up the Database to Disk

This example backs up the multitenant container database (CDB) to disk:

```
BACKUP DEVICE TYPE DISK DATABASE;
```

## 4.8 fileNameConversionSpec

### Purpose

Use the *fileNameConversionSpec* subclause to specify one or more patterns to be used in generating new file names based on old file names. Used with [BACKUP](#), [CONVERT](#), and [DUPLICATE](#) as one way of generating output file names.

### Usage Notes

The rules for string patterns and how they affect file naming equal those for the initialization parameter `DB_FILE_NAME_CONVERT`. In parentheses, provide an even number of string patterns.

When RMAN generates a new file name based on an old one, it compares the original file name to the first member of each pair of string patterns. The first time that RMAN finds a pattern that is a substring of the original file name, RMAN generates the new file name by substituting the second member of the pair for the substring that matched.

The pattern does not have to match at the beginning of the file name. The following command creates an image copy of data file `/disk1/dbs/users.dbf` as `/disk1/newdbs/users.dbf`:

```
BACKUP AS COPY
  DB_FILE_NAME_CONVERT = ('dbs','newdbs');
  TABLESPACE users;
```

When multiple possible matches exist for a given file name being converted, RMAN uses the first match in the list of patterns to generate the new file name. The following command has the same effect as the previous example because the pattern `db`s matches the file name, so that the file name is never compared to the second pattern `/disk1`:

```
BACKUP AS COPY
  DB_FILE_NAME_CONVERT = ('dbs','newdbs','/disk1','/newdisk')
  TABLESPACE users;
```

For the `CONVERT TABLESPACE`, `CONVERT DATABASE`, and `BACKUP AS COPY` commands, if the source files for these operations are Oracle-managed files, then you cannot use `fileNameConversionSpec` to convert the source file names into new output file names. For Oracle-managed files, either in Automated Storage Management (ASM) or in ordinary file system storage, the database must be allowed to generate the file names for the output files. For example, an OMF file name for a data file in non-ASM storage might be of the following form:

```
/private/boston/datafile/01_mf_system_ab12554_.dbf
```

An OMF file name in ASM storage might be of the following form:

```
+DISK/boston/datafile/system.256.4543080
```

Only the database can generate and manage OMF file names. Typically, substituting the name of a different disk group or a different OMF location into an OMF file name does not produce a valid file name in the new destination. To convert OMF file names for storage in another OMF location, use an alternative such as a `FORMAT` clause with these commands to specify the new output location and allow the database to manage the specific output file names.

### Syntax

**fileNameConversionSpec::=**

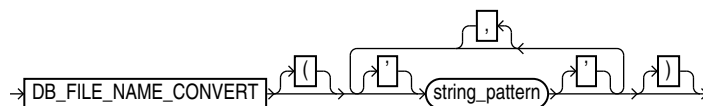

### Semantics

Syntax Element	Description
<code>string_pattern</code>	<p>Specifies pairs of strings used to convert the file names. For example, you could set the string pattern to a value such as:</p> <pre>DB_FILE_NAME_CONVERT = ('str1','str2','str3', 'str4' ...)</pre> <p>In this example, <code>str1</code> is a pattern matching the original file name, <code>str2</code> is the pattern replacing <code>str1</code> in the generated file name, <code>str3</code> is a pattern matching the original file name, and <code>str4</code> is the pattern replacing <code>str3</code> in the generated file name.</p> <p><b>Note:</b> You can specify multiple pairs of primary and standby replacement strings for this parameter, however, starting with Oracle Database 12c Release 2 (12.2), Oracle recommends that you limit the number of pairs to 99.</p>

## Examples

### Example 4-17 Using DB\_FILE\_NAME\_CONVERT with a Single Conversion Pair

In this example, the tablespace `users` contains data files in directory `/disk1/oradata/prod/`, whereas tablespace `tools` contains data files in `/disk1/oradata/prod/`. For each data file to be converted, if `disk1/oradata/prod` is a substring of the data file name, then the image copy name is created by replacing the string with `disk2`.

```
BACKUP AS COPY
  DB_FILE_NAME_CONVERT = ('disk1/oradata/prod','disk2')
  TABLESPACE users, tools;
```

### Example 4-18 Using DB\_FILE\_NAME\_CONVERT with Multiple Conversion Pairs

This example creates image copies of the same data files described in [Example 4-17](#). The first string in each pair specifies a pattern to match in the name of the source data files. The second string in each pair is the substitution pattern to use when generating the names of the image copies.

```
BACKUP AS COPY
  DB_FILE_NAME_CONVERT=('/disk1/oradata/prod/users','/disk2/users',
                       '/disk1/oradata/prod/tools','/tmp/tools')
  TABLESPACE tools, users;
```

The following sample output for this command demonstrates how RMAN uses the conversion pairs to name the output image copies:

```
Starting backup at 08-MAR-13
using channel ORA_DISK_1
channel ORA_DISK_1: starting datafile copy
input datafile file number=00027 name=/disk1/oradata/prod/tools01.dbf
output file name=/tmp/tools01.dbf tag=TAG20130308T143300 RECID=33 STAMP=616689181
channel ORA_DISK_1: datafile copy complete, elapsed time: 00:00:01
channel ORA_DISK_1: starting datafile copy
input datafile file number=00028 name=/disk1/oradata/prod/users01.dbf
output file name=/disk2/users01.dbf tag=TAG20130308T143300 RECID=34 STAMP=616689182
channel ORA_DISK_1: datafile copy complete, elapsed time: 00:00:01
Finished backup at 08-MAR-13
```

```
Starting Control File and SPFILE Autobackup at 08-MAR-13
piece handle=/disk2/PROD/autobackup/2013_03_08/o1_mf_s_616689184_2z13s1kx_.bkp comment=NONE
Finished Control File and SPFILE Autobackup at 08-MAR-13
```

## 4.9 forDbUniqueNameOption

### Purpose

Use the *forDbUniqueNameOption* subclause to specify either all databases or a specific database in a Data Guard environment.

### Usage Notes

The DBID for a primary database is identical to the DBID of its associated physical standby databases. A database is uniquely identified in the recovery catalog by a DBID and the value of its `DB_UNIQUE_NAME` initialization parameter.

When you specify *forDbUniqueNameOption* for any command, RMAN restricts its operations to the objects that are associated exclusively with the database with the specified `DB_UNIQUE_NAME`. For example, if you use this option with the [LIST](#) command, then RMAN lists

only the objects associated exclusively with the database with the specified `DB_UNIQUE_NAME`. Objects that are not associated with any database (`SITE_KEY` column in the recovery catalog view is `null`) are not listed.

### Syntax

**forDbUniqueNameOption::=**

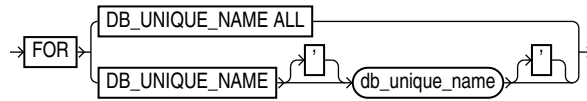

### Semantics

Syntax Element	Description
FOR DB_UNIQUE_NAME ALL	Specifies all primary and standby databases in the recovery catalog that share the DBID of the target database (or DBID specified by the <a href="#">SET DBID</a> command).
FOR DB_UNIQUE_NAME <i>db_unique_name</i>	Specifies the primary or standby database in the recovery catalog with the specified <i>db_unique_name</i> .

### Examples

#### Example 4-19 Listing Expired Backups Associated with a Standby Database

This example connects to a recovery catalog and sets the DBID for the Data Guard environment. All primary and standby databases in this environment share the same DBID. The `LIST` command lists all expired backups associated with database `standby1`:

```

RMAN> CONNECT CATALOG rco@catdb;

recovery catalog database Password: password
connected to recovery catalog database

RMAN> SET DBID 3257174182;
RMAN> LIST EXPIRED BACKUP FOR DB_UNIQUE_NAME standby1;
  
```

## 4.10 foreignFileSpec

### Purpose

Use the *foreignFileSpec* subclause to provide the information required to perform a cross-platform restore operation. This information includes the name of the backup set that contains the cross-platform backup and details of objects or files that must be restored.

### Usage Notes

Specifying a *foreignFileSpec* is mandatory to perform a cross-platform restore operation. You can restore tablespaces even if the source platform and the destination platform use different endian formats.

**Syntax**

**foreignFileSpec::=**

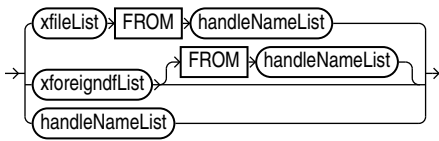

(xfileList::=, xforeigndfList::=, handleNameList::=)

**xfileList::=**

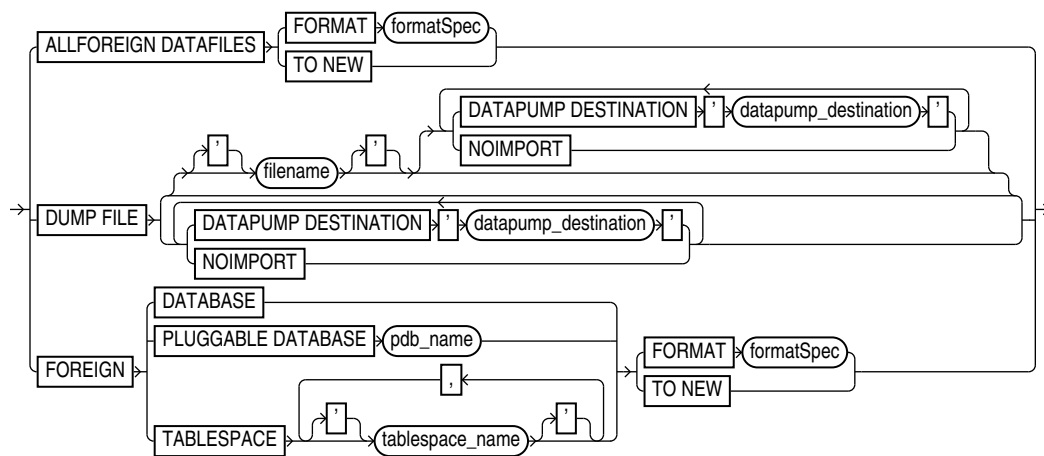

**xforeigndfList::=**

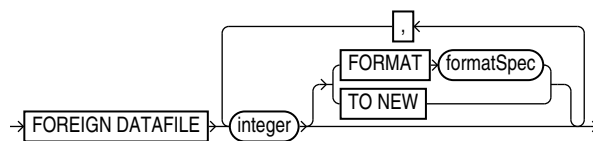

**handleNameList::=**



## Semantics

***xfilelist::=***

Syntax Element	Description
ALL FOREIGN DATAFILES	Specifies that all the data files contained in the cross-platform backup set must be restored. Use <code>FROM BACKUPSET</code> along with <code>ALL FOREIGN DATAFILES</code> to specify the name of the backup set that contains the data files to be restored.
FORMAT <i>formatSpec</i>	Specifies a pattern for the restored data files in the destination database.
TO NEW	Specifies that the data files must be restored to the location specified by the <code>DB_CREATE_FILE_DEST</code> initialization parameter using Oracle Managed File (OMF) names.
DUMP FILE ' <i>filename</i> '	Specifies that the backup set containing the Data Pump export dump file must be restored. The name of the backup set containing the dump file is specified using the <code>FROM BACKUPSET</code> clause. The dump file contains the metadata of the tablespaces that are being transported across platforms. You need this metadata to plug the restored tablespaces into the destination database. <i>filename</i> represents the name of the file into which the export dump file is restored.
DATAPUMP DESTINATION ' <i>datapump_destination</i> '	Specifies the location to which the export dump file must be restored. If you omit this clause, the export dump file is restored to an operating system-dependent default location. The database must be opened in read-write mode when this clause is used, otherwise an error occurs.
NOIMPORT	Specifies that the export dump file must be restored, but not imported into the destination database. Because the export dump file is not imported, the tablespaces are not plugged in to the destination database. You need to manually import the dump file into the destination database using the Data Pump Import to plug the tablespaces.
FOREIGN DATABASE	Specifies that the entire CDB must be restored from a cross-platform backup set. Use <code>FROM BACKUPSET</code> to specify the backup set that contains the cross-platform database backup. When <code>FOREIGN DATABASE</code> is used, the CDB must not be mounted, else an error occurs.
FOREIGN PLUGGABLE DATABASE <i>pdb_name</i>	Specifies that the pluggable database (PDB) specified by <i>pdb_name</i> must be restored from a cross-platform backup set. Use <code>FROM BACKUPSET</code> to specify the backup set that contains the cross-platform PDB backup. The CDB must not be mounted or else an error occurs.
FOREIGN TABLESPACE <i>tablespace_name</i>	Specifies the tablespaces that must be restored from the cross-platform backup set. The names of the tablespaces must be the original tablespaces names in the source database. Use <code>FROM BACKUPSET</code> to specify the name of the backup set that contains the cross-platform backup.

***xforeigndfList::=***

Syntax Element	Description
FOREIGN DATAFILE <i>integer</i>	Restores the specified data files that are contained in a cross-platform backup. You can choose to restore only some of the data files contained in the cross-platform backup set. Use FROM BACKUPSET to specify the name of the backup set that contains the cross-platform backup.  <i>integer</i> specifies the absolute number of the data file in the source database.
FORMAT <i>formatSpec</i>	Specifies a pattern for the restored data files in the destination database.
TO NEW	Specifies that the data files must be restored to the location specified by the DB_CREATE_FILE_DEST initialization parameter using Oracle Managed File (OMF) names.

### ***handleNameList::=***

Syntax Element	Description
BACKUPSET <i>filename</i>	Specifies the backup set that contains the cross-platform backup that must be restored.  Most backup sets contain only one backup piece. However, you can create a backup consisting of multiple backup pieces by configuring MAXPIECESIZE to specify the maximum size of each backup piece. When a backup set contains multiple backup pieces, the FROM BACKUPSET clause must include a comma-separated list of all the backup pieces in the backup set. The order of the backup pieces must be from the first piece to the last piece. If this order is not followed, the restore operation fails. See <a href="#">Example 3-39</a> for a RESTORE command that contains multiple backup pieces.  If a cross-platform backup consists of multiple backup sets, then you must use a separate BACKUPSET clause for each backup set that was created as part of the cross-platform backup. See <a href="#">Example 3-38</a> for a RESTORE command that contains multiple backup sets.

## Examples

### Example 4-20 Restoring all Data files from a Cross-Platform Backup

In the following example, the backup set `Oelmdipc_1_1` was created in the source database for cross-platform tablespace transport. The `RESTORE` command, with `foreignFileSpec`, is used to restore all data files contained in this cross-platform backup in the destination database. The destination database must be open in read-write mode.

```
RESTORE
  ALL FOREIGN DATAFILES TO NEW
  FROM BACKUPSET '/net/oracle/restores/Oelmdipc_1_1';
```



#### See Also:

"RESTORE" for additional examples on restoring cross-platform backups



## 4.11 foreignlogRecordSpecifier

### Purpose

Use the *foreignlogRecordSpecifier* subclause to specify a set of foreign archived redo log files for use in RMAN operations.

### Usage Notes

Foreign archived redo log files are received by a logical standby database for a LogMiner session. Unlike normal archived logs, foreign archived logs have a different DBID. For this reason, they cannot be backed up or restored on a logical standby database.

A logical standby database creates foreign archived logs in the fast recovery area if the following conditions are met:

- A fast recovery area is configured on the logical standby database.
- a LOG\_ARCHIVE\_DEST\_n initialization parameters is set to 'LOCATION=USE\_DB\_RECOVERY\_FILE\_DEST' with a proper VALID\_FOR setting to receive foreign archived logs.
- The COMPATIBLE initialization parameter is set to a value greater than or equal to 11.0.0.

### Syntax

**foreignlogRecordSpecifier::=**

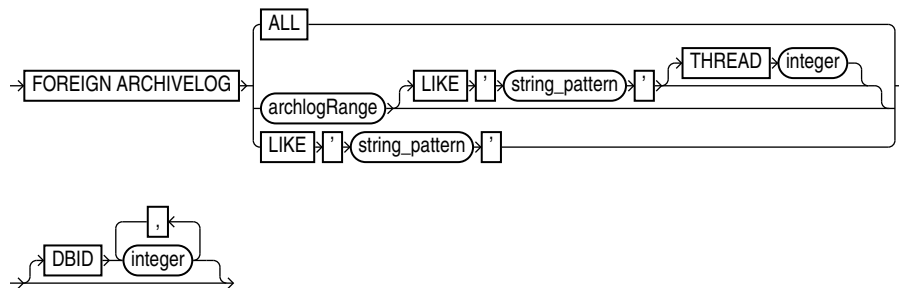

**archlogRange::=**

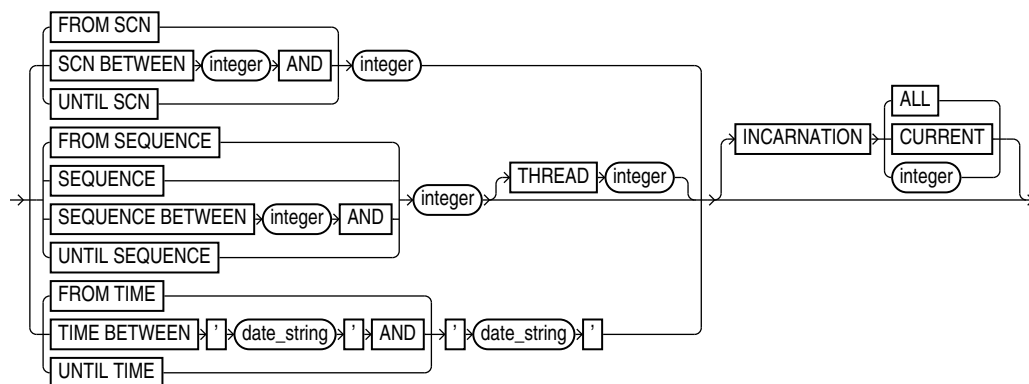

## Semantics

The semantics duplicate [archiveLogRecordSpecifier](#) except that the logs are foreign archived redo log files.

## Examples

### Example 4-21 Crosschecking Foreign Archived Redo Log Files

This example crosschecks all foreign archived redo log files:

```
RMAN> CROSSCHECK FOREIGN ARCHIVELOG ALL;
```

## 4.12 formatSpec

### Purpose

Use the *formatSpec* subclause to specify a file name format or an Automatic Storage Management disk group for a backup piece or image copy. If you do not specify a value for the `FORMAT` parameter, then RMAN either creates the backup in the fast recovery area if it is enabled, or in a platform-specific directory (for example, `*/dbs` on UNIX) if a fast recovery area is not enabled. In either case, RMAN uses the variable `%U` to name the backup.

#### Tip:

*Oracle Database SQL Language Reference* to learn how to create and name Automated Storage Manager disk groups

### Usage Notes

Any name that is valid as a sequential file name on the platform is allowed, so long as each backup piece or copy has a unique name. If backing up to disk, then any valid disk file name is allowed, provided it is unique.

You cannot specify an Oracle Managed Files file name as the format for a backup. For example, if `+DISK1/datafile/system.732.609791431` is an OMF file name, then you cannot specify this file name in the `FORMAT` parameter.

Environment variables are not valid in the `FORMAT` parameter.

The entire *format\_string* is processed in a port-specific manner by the target instance to derive the final backup piece name. The substitution variables listed in "[Semantics](#)" are available in `FORMAT` strings to aid in generating unique file names. The formatting of this information varies by platform.

You can specify up to four `FORMAT` strings. RMAN uses the second, third, and fourth values only when `BACKUP COPIES`, `SET BACKUP COPIES`, or `CONFIGURE ... BACKUP COPIES` is in effect. When choosing the format for each backup piece, RMAN uses the first format value for copy 1, the second format value for copy 2, and so on. If the number of format values exceeds the number of copies, then the extra formats are not used. If the number of format values is less than the number of copies, then RMAN reuses the format values, starting with the first one.

Specify *format\_string* in any of the following places, listed in order of precedence:

1. The `backupSpec` clause
2. The `BACKUP` command
3. The `ALLOCATE CHANNEL` command
4. The `CONFIGURE CHANNEL` command

If it is specified in multiple places, then RMAN searches for the `FORMAT` parameter in the order shown.

## Syntax

**formatSpec::=**

→ 'format\_string' →

## Semantics

### formatSpec

The following table lists RMAN substitution variables that are valid in format strings.

Syntax Element	Description
%a	Specifies the activation ID of the database.
%b	Specifies the file name stripped of directory paths. It is only valid for <code>SET NEWNAME</code> and backup resetwhen producing image copies. It yields errors if used as a format specification for a backup that produces backup pieces.
%c	Specifies the copy number of the backup piece within a set of duplexed backup pieces. If you did not duplex a backup, then this variable is 1 for backup sets and 0 for proxy copies. If a command is enabled, then the variable shows the copy number. The maximum value for %c is 256.
%d	Specifies the name of the database (see <a href="#">Example 4-23</a> ).
%D	Specifies the current day of the month from the Gregorian calendar in format DD.
%e	Specifies the archived log sequence number.
%f	Specifies the absolute file number (see <a href="#">Example 4-23</a> ).
%F	Combines the DBID, day, month, year, and sequence into a unique and repeatable generated name. This variable translates into <code>c-#####-YYYYMMDD-QQ</code> , where: <ul style="list-style-type: none"> <li>• ##### stands for the DBID. The DBID is printed in decimal so that it can be easily associated with the target database.</li> <li>• YYYYMMDD is a time stamp in the Gregorian calendar of the day the backup is generated</li> <li>• QQ is the sequence in hexadecimal number that starts with 00 and has a maximum of 'FF' (256)</li> </ul> <p><b>Note:</b> %F is valid only in the <code>CONFIGURE CONTROLFILE AUTOBACKUP FORMAT</code> command.</p>
%h	Specifies the archived redo log thread number.
%I	Specifies the DBID.
%M	Specifies the month in the Gregorian calendar in format MM.
%N	Specifies the tablespace name. This substitution variable is only valid when backing up data files as image copies.

Syntax Element	Description
%n	Specifies the name of the database, padded on the right with <i>x</i> characters to a total length of eight characters. For example, if <code>prod1</code> is the database name, then the padded name is <code>prod1xxx</code> .
%p	Specifies the piece number within the backup set. This value starts at 1 for each backup set and is incremented by 1 as each backup piece is created. <b>Note:</b> If you specify <code>PROXY</code> , then the <code>%p</code> variable must be included in the <code>FORMAT</code> string either explicitly or implicitly within <code>%U</code> .
%r	Specifies the resetlogs ID.
%s	Specifies the backup set number. This number is a counter in the control file that is incremented for each backup set. The counter value starts at 1 and is unique for the lifetime of the control file. If you restore a backup control file, then duplicate values can result. Also, <code>CREATE CONTROLFILE</code> initializes the counter back to 1.
%t	Specifies the backup set time stamp, which is a 4-byte value derived as the number of seconds elapsed since a fixed reference time. You can use a combination of <code>%s</code> and <code>%t</code> to form a unique name for the backup set.
%T	Specifies the year, month, and day in the Gregorian calendar in this format: <code>YYYYMMDD</code> .
%u	Specifies an 8-character name constituted by compressed representations of the backup set or image copy number and the time the backup set or image copy was created.
%U	Specifies a system-generated unique file name (default). The meaning of <code>%U</code> is different for image copies and backup pieces. For a backup piece, <code>%U</code> specifies a convenient shorthand for <code>%u_%p_%c</code> that guarantees uniqueness in generated backup file names. For an image copy of a data file, <code>%U</code> means the following: <code>data-D-%d_id-%I_TS-%N_FNO-%f_%u</code> For an image copy of an archived redo log, <code>%U</code> means the following: <code>arch-D_%d-id-%I_S-%e_T-%h_A-%a_%u</code> For an image copy of a control file, <code>%U</code> means the following: <code>cf-D_%d-id-%I_%u</code>
%Y	Specifies the year in this format: <code>YYYY</code> .
%%	Specifies the percent (%) character. For example, <code>%%Y</code> translates to the string <code>%Y</code> .

## Example

### Example 4-22 Specifying an ASM Disk Group

This example copies the database to ASM disk group `DISK1`:

```
BACKUP AS COPY DATABASE FORMAT '+DISK1';
```

### Example 4-23 Specifying a Format for Data File Copies

This example copies two data files with tag `LATESTCOPY` to directory `/disk2`:

```
BACKUP AS COPY
  COPY OF DATAFILE 27, 28
  FROM TAG 'LATESTCOPY'
  FORMAT '/disk2/Datafile%f_Database%d';
```

## 4.13 keepOption

### Purpose

Use the *keepOption* subclause to specify the status of a backup or copy in relation to a retention policy.

### Syntax

**keepOption::=**

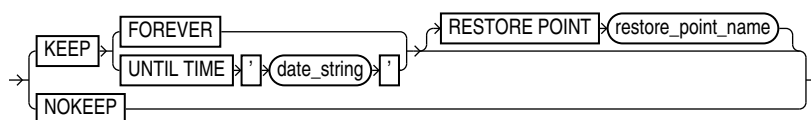

### Usage Notes

RMAN does not consider backup pieces with the `KEEP` option when computing the backup retention policy. If available, RMAN uses these backups for disaster recovery restore operations, but their purpose is to produce a snapshot of the database that can be restored on another system for testing or historical usage.

When creating archival backups with `KEEP`, RMAN only considers `KEEP` backups with the same tag. Thus, when using *keepOption* with *notBackedUpSpec*, RMAN only skips a backup if it finds the specified maximum number of `KEEP` backups with the same tag. Other backups are not counted.

## Semantics

Syntax Element	Description
KEEP	<p>Specifies the backup as an <b>archival backup</b>, which is a self-contained backup that is exempt from the configured retention policy.</p> <p>An archival backup is self-contained because it contains all files necessary to restore the backup and recover it to a consistent state. If the database is open during the backup, then RMAN automatically generates and backs up the archived redo log files needed to make the database backup consistent (see <a href="#">Example 2-26</a>).</p> <p><b>Note:</b> PDB backups are self-contained only when local undo is used. When shared undo is used, PDB backups are not self-contained.</p> <p>RMAN does not consider backup pieces with the KEEP option when computing the retention policy. If available, RMAN uses these backups for disaster recovery restore operations, but their purpose is to produce a snapshot of the database that can be restored on another system for testing or historical usage.</p> <p><b>Note:</b> You cannot use KEEP to override the retention policy for files stored in the fast recovery area. If you specify KEEP when backing up to the recovery area, then RMAN issues an error.</p> <p>When KEEP is specified, RMAN creates multiple backup sets. RMAN backs up data files, archived redo log files, the control file, and the server parameter file with the options specified in the first <i>backupOperand</i>. Since a backup of the control file is created, an autobackup of the control file is not created. RMAN uses the FORMAT, POOL, and TAG parameters for all the backups. For this reason, the FORMAT string must allow for the creation of multiple backup pieces. Specifying %U is the easiest way to meet this requirement.</p> <p><b>See Also:</b> <a href="#">CONFIGURE</a> and <i>Oracle Database Backup and Recovery User's Guide</i> to learn more about autobackup of the control file.</p> <p>When KEEP is specified with INCREMENTAL LEVEL, the parent backup must be a KEEP backup and have the same TAG string. Unless both these criteria are met, the backup cannot be created. Backups that meet these criteria do not interfere with other nightly or archival backup tasks.</p> <p><b>Note:</b> A recovery catalog is only required for KEEP FOREVER. No other KEEP options require a catalog.</p>
FOREVER	<p>Specifies that the backup or copy never becomes obsolete (see <a href="#">Example 2-27</a>). A recovery catalog is required when FOREVER is specified because the backup records eventually age out of the control file.</p>
UNTIL TIME 'date_string'	<p>Specifies the time until which the backup or copy must be kept. After this time the backup is obsolete, regardless of the backup retention policy settings.</p> <p>You can either specify a specific time by using the current NLS_DATE_FORMAT, or a SQL date expression such as 'SYSDATE+365'. If you specify a KEEP TIME such as 01-JAN-13, then the backup becomes obsolete one second after midnight on this date. If you specify a KEEP time such as 9:00 p.m., then the backup becomes obsolete at 9:01 p.m.</p>
RESTORE POINT restore_point_name	<p>Creates a normal restore point matching the SCN to which RMAN must recover the backup to a consistent state (see <a href="#">Example 2-26</a>). The restore point name must not already exist.</p> <p>The SCN is captured just after the data file backups complete. The restore point is a label for the SCN to which this archival backup can be restored and recovered, enabling the database to be opened. In contrast, the UNTIL TIME clause specifies the date until which the backup must be kept.</p> <p><b>Note:</b> The RESTORE POINT parameter is not valid with the <a href="#">CHANGE</a> command.</p>

Syntax Element	Description
NOKEEP	Specifies that any <code>KEEP</code> attributes no longer apply to the backup. Thus, the backup is a normal backup that is subject to the configured backup retention policy. This is the default behavior if no <code>KEEP</code> option is specified.

## Examples

### Example 4-24 Creating a Consistent Database Backup for Archival

This example makes a database backup with tag `Q107` and specifies that it is never considered obsolete (partial sample output included). The archived redo log files necessary to make the data files consistent are included in the backup set.

```
RMAN> BACKUP TAG Q107 DATABASE KEEP FOREVER;
```

```
Starting backup at 24-JAN-13
```

```
current log archived
allocated channel: ORA_SBT_TAPE_1
channel ORA_SBT_TAPE_1: SID=105 device type=SBT_TAPE
channel ORA_SBT_TAPE_1: Oracle Secure Backup
backup will never be obsolete
archived logs required to recover from this backup will be backed up
channel ORA_SBT_TAPE_1: starting full datafile backup set
channel ORA_SBT_TAPE_1: specifying datafile(s) in backup set
.
.
.
```

### Example 4-25 Removing the KEEP Attributes for a Backup

This example backs up all archived redo log files. The `KEEP` clause specifies that one second after midnight on January 1, 2013 the backup is considered obsolete.

```
RMAN> BACKUP KEEP UNTIL TIME '01-JAN-13' ARCHIVELOG ALL;
```

The following command removes the `KEEP` attributes of all archived redo log backups (sample output included):

```
RMAN> CHANGE BACKUP OF ARCHIVELOG ALL NOKEEP;
```

```
using channel ORA_SBT_TAPE_1
allocated channel: ORA_DISK_1
channel ORA_DISK_1: SID=77 device type=DISK
keep attributes for the backup are deleted
backup set key=330 RECID=19 STAMP=612722760
keep attributes for the backup are deleted
backup set key=397 RECID=22 STAMP=612722884
```

## 4.14 listObjList

### Purpose

Use the `listObjList` subclause to specify database files and archived redo log files.

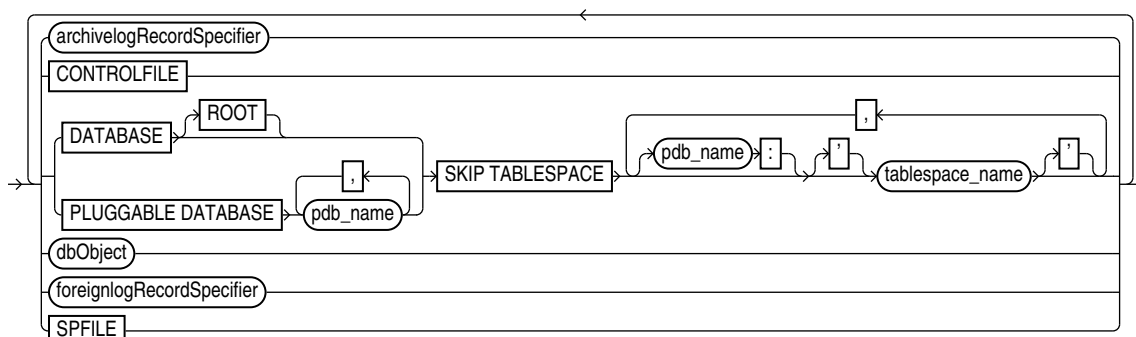
**Syntax****listObjList::=**

(archiveLogRecordSpecifier::=, dbObject::=, foreignLogRecordSpecifier::=)

**Semantics**

Syntax Element	Description
<a href="#">archiveLogRecordSpecifier</a>	Specifies a range of archived redo log files. <b>See Also:</b> <a href="#">archiveLogRecordSpecifier</a>
CONTROLFILE	Specifies the current control file.
DATABASE	Specifies the whole CDB.
DATABASE ROOT	Specifies only the CDB root.
PLUGGABLE DATABASE <i>pdb_name</i>	Specifies one or more pluggable databases (PDBs) in a CDB. Use a comma-delimited list to specify multiple PDBs.
SKIP TABLESPACE <i>tablespace_name</i>	Omits the specified tablespaces in the root.
SKIP TABLESPACE <i>pdb_name:tablespace_name</i>	The name of the tablespace in a PDB. Multiple PDBs can have tablespaces with the same name. A qualifier before the name uniquely identifies the tablespace. <i>pdb_name</i> is the name of a PDB.
<a href="#">foreignLogRecordSpecifier</a>	Processes the specified foreign archived redo log files. <b>See Also:</b> <a href="#">foreignLogRecordSpecifier</a>
SPFILE	Specifies the current server parameter file.

**Examples****Example 4-26 Listing Data File Copies**

The following command lists image copies of all the files in the database, skipping the `temp` tablespace, which is a dictionary-managed temporary tablespace:

```
LIST COPY OF DATABASE
  SKIP TABLESPACE temp;
```

**Example 4-27 Listing Data Files for a PDB**

The following command lists the backups of the PDB `hr_pdb`. Connect to the root as a common user with the `SYBACKUP` privilege before running this command.



```
LIST BACKUP OF PLUGGABLE DATABASE hr_pdb;
```

### Example 4-28 Crosschecking Archived Redo Log Files

The following example queries the media manager for the status of server parameter file and archived redo log backups created in the last three months. The example includes sample output.

```

RMAN> ALLOCATE CHANNEL FOR MAINTENANCE DEVICE TYPE sbt;

allocated channel: ORA_MAINT_SBT_TAPE_1
channel ORA_MAINT_SBT_TAPE_1: SID=103 device type=SBT_TAPE
channel ORA_MAINT_SBT_TAPE_1: Oracle Secure Backup

RMAN> CROSSCHECK BACKUP OF SPFILE ARCHIVELOG FROM TIME 'SYSDATE-90';

crosschecked backup piece: found to be 'AVAILABLE'
backup piece handle=8cic4031_1_1 RECID=195 STAMP=616693857
crosschecked backup piece: found to be 'AVAILABLE'
backup piece handle=c-28014364-20130308-15 RECID=196 STAMP=616693875
Crosschecked 2 objects

RMAN> RELEASE CHANNEL;

released channel: ORA_MAINT_SBT_TAPE_1

```

### Example 4-29 Deleting Expired Backups

The following command performs a crosscheck of all backups. One backup is found to be expired. The example then deletes all expired backups (sample output included).

```

RMAN> CROSSCHECK BACKUP;

allocated channel: ORA_SBT_TAPE_1
channel ORA_SBT_TAPE_1: SID=104 device type=SBT_TAPE
channel ORA_SBT_TAPE_1: Oracle Secure Backup
allocated channel: ORA_DISK_1
channel ORA_DISK_1: SID=103 device type=DISK
crosschecked backup piece: found to be 'EXPIRED'
backup piece handle=/disk2/PROD/autobackup/2013_03_08/o1_mf_s_616690991_2z15k15h_.bkp
  RECID=191 STAMP=616690994
crosschecked backup piece: found to be 'AVAILABLE'
backup piece handle=8cic4031_1_1 RECID=195 STAMP=616693857
crosschecked backup piece: found to be 'AVAILABLE'
backup piece handle=c-28014364-20130308-15 RECID=196 STAMP=616693875
Crosschecked 3 objects

RMAN> DELETE EXPIRED BACKUP;

using channel ORA_SBT_TAPE_1
using channel ORA_DISK_1

List of Backup Pieces
BP Key   BS Key   Pc# Cp# Status       Device Type Piece Name
-----
7678    7677    1  1  EXPIRED     DISK
/disk2/PROD/autobackup/2013_03_08/o1_mf_s_616690991_2z15k15h_.bkp

Do you really want to delete the above objects (enter YES or NO)? YES
deleted backup piece
backup piece handle=/disk2/PROD/autobackup/2013_03_08/o1_mf_s_616690991_2z15k15h_.bkp
  RECID=191 STAMP=616690994
Deleted 1 EXPIRED objects

```

## 4.15 maintQualifier

### Purpose

Use the *maintQualifier* subclause to specify database files and archived redo log files.

### Syntax

***maintQualifier*::=**

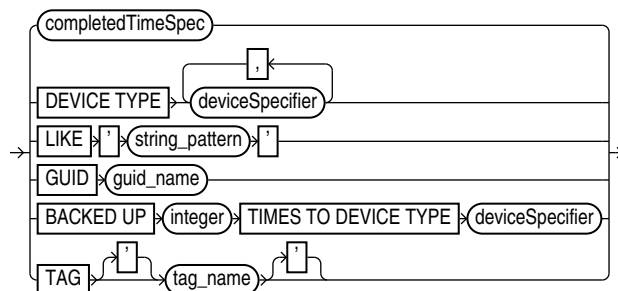

([completedTimeSpec::=](#), [deviceSpecifier::=](#))

### Semantics

***maintQualifier***

Syntax Element	Description
<a href="#">completedTimeSpec</a>	Specifies a range of time for completion of the backup or copy. <b>See Also:</b> <a href="#">completedTimeSpec</a>
DEVICE TYPE <a href="#">deviceSpecifier</a>	Allocates automatic channels for the specified device type only. This option is valid only if you have configured automatic channels and have not manually allocated channels. For example, if you configure automatic disk and tape channels, and issue CHANGE...DEVICE TYPE DISK, then RMAN allocates only disk channels. <b>See Also:</b> <a href="#">deviceSpecifier</a>
LIKE 'string_pattern'	Restricts data file copies by specifying a file name pattern. The pattern can contain Oracle pattern matching characters percent sign (%) and underscore (_). RMAN only operates on those files whose name matches the pattern. <b>Note:</b> You cannot use the LIKE option with the LIST...ARCHIVELOG command or with backup pieces.
GUID <i>guid_name</i>	Specifies the GUID of the pluggable database (PDB) on which the specified action is performed. Each PDB is identified using a unique GUID. You can determine the GUID of a dropped PDB by querying the <code>dba_pdb_history</code> view.

Syntax Element	Description
BACKED UP <i>integer</i> TIMES TO DEVICE TYPE <a href="#">deviceSpecifier</a>	<p>Restricts the command to archived logs and backup sets that have been successfully backed up <i>integer</i> or more times to the specified media.</p> <p>When the BACKED UP option is used with the <a href="#">DELETE</a> ARCHIVELOG command, RMAN uses the BACKED UP setting rather than the configured settings to determine whether an archived log can be deleted. That is, <a href="#">CONFIGURE ARCHIVELOG DELETION POLICY</a> is overridden. Use FORCE with DELETE ARCHIVELOG to override this configuration and any mismatches between media and repository.</p>
TAG <i>tag_name</i>	<p>Specifies the data file copies and backup sets by tag. Tag names are not case sensitive and display in all uppercase.</p> <p><b>See Also:</b> <a href="#">BACKUP</a> for a description of how a tag can be applied to an individual copy of a duplexed backup set, and also for a description of the default file name format for tags</p>

## Example

### Example 4-30 Listing Backups in a Specific Location

The following command lists all image copies located in directory `/disk2`:

```
RMAN> LIST COPY LIKE '/disk2/%';

List of Datafile Copies
=====

Key      File S Completion Time Ckp SCN      Ckp Time
-----
9855     1    A 08-MAR-13      1394701     08-MAR-13
        Name: /disk2/data_D-PROD_I-28014364_TS-SYSTEM_FNO-1_8eic410j
        Tag: TAG20130308TI60643

9856     2    A 08-MAR-13      1394735     08-MAR-13
        Name: /disk2/data_D-PROD_I-28014364_TS-SYSAUX_FNO-2_8fic412a
        Tag: TAG20130308TI60643
```

### Example 4-31 Deleting Archived Logs That Are Backed Up

The following command deletes only those archived logs that have been successfully backed up two or more times to tape. In this example, only the sequence 36 archived log meets these criteria.

```
RMAN> DELETE ARCHIVELOG ALL BACKED UP 2 TIMES TO DEVICE TYPE sbt;

released channel: ORA_SBT_TAPE_1
allocated channel: ORA_DISK_1
channel ORA_DISK_1: SID=104 device type=DISK
RMAN-08138: WARNING: archived log not deleted - must create more backups
archived log file name=/disk1/oradata/prod/arch/archiver_1_37_616443024.arc thread=1
sequence=37
List of Archived Log Copies for database with db_unique_name PROD
=====

Key      Thrd Seq      S Low Time
-----
9940     1    36      A 08-MAR-13
        Name: /disk1/oradata/prod/arch/archiver_1_36_616443024.arc

Do you really want to delete the above objects (enter YES or NO)? Y
deleted archived log
```

```

archived log file name=/disk1/oradata/prod/arch/archiver_1_36_616443024.arc RECID=129
STAMP=616695115
Deleted 1 objects

```

## 4.16 maintSpec

### Purpose

Use the *maintSpec* subclause to specify the backup files operated on by the [CHANGE](#), [CROSSCHECK](#), and [DELETE](#) commands.

### Syntax

***maintSpec*::=**

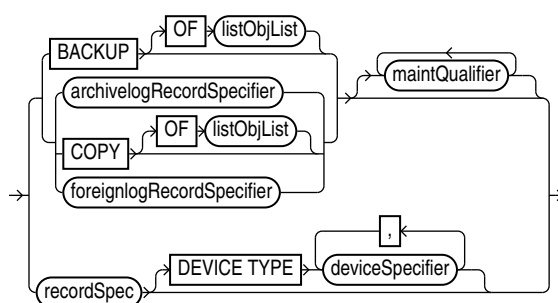

([listObjList::=](#), [maintQualifier::=](#), [archivelogRecordSpecifier::=](#), [recordSpec::=](#), [deviceSpecifier::=](#))

### Semantics

***maintSpec***

Syntax Element	Description
BACKUP	Processes backup sets. For processing image copies, use the option <code>COPY</code> . If you do not use the <code>OF</code> clause with <a href="#">CHANGE</a> BACKUP, then RMAN changes all backup sets recorded in the repository. If you do not use the <code>OF</code> clause with <a href="#">CROSSCHECK</a> BACKUP, then RMAN crosschecks backups of the whole database. If you do not use the <code>OF</code> clause with <a href="#">DELETE</a> BACKUP, then RMAN deletes backups of the whole database.
<code>OF</code> <a href="#">listObjList</a>	Restricts the list of files operated on to the object type specified in the <i>listObjList</i> clause. <b>See Also:</b> <a href="#">listObjList</a>

Syntax Element	Description
<a href="#">archivelogRecordSpecifier</a>	<p>Processes the specified archived redo log files.</p> <p>If you specify <b>DELETE ARCHIVELOG</b> without the <b>BACKED UP</b> clause, then RMAN uses the configured settings to determine whether an archived log can be deleted (<b>CONFIGURE ARCHIVELOG DELETION POLICY TO BACKED UP</b>). If you specify <b>DELETE ARCHIVELOG</b> with the <b>BACKED UP</b> clause, then RMAN uses the <b>DELETE</b> settings to determine whether an archived log can be deleted. Use <b>FORCE</b> with <b>DELETE ARCHIVELOG</b> to override a configured deletion policy and any mismatches between media and repository.</p> <p><b>See Also:</b> <a href="#">archivelogRecordSpecifier</a></p>
<b>COPY</b>	<p>Processes data file copies, control file copies, and archived redo log files.</p> <p>If you do not specify an option for <b>CHANGE COPY</b>, then the command operates on all image copies recorded in the repository. If you are using <b>CROSSCHECK COPY</b>, then by default the command checks all image copies of all files in the database with status <b>AVAILABLE</b> or <b>EXPIRED</b>. If you are using <b>DELETE COPY</b>, then by default <b>COPY</b> removes copies of all files in the database. Specify the <b>EXPIRED</b> option to remove only copies that are marked <b>EXPIRED</b> in the repository.</p>
<b>OF</b> <a href="#">listObjList</a>	<p>Restricts the list of objects operated on to the object type specified in the <i>listObjList</i> clause. If you do not specify an object, then the command defaults to all copies. <b>CHANGE COPY OF DATABASE</b> includes data files but not control files.</p> <p><b>See Also:</b> <a href="#">listObjList</a></p>
<a href="#">foreignlogRecordSpecifier</a>	<p>Processes the specified foreign archived redo log files.</p> <p><b>See Also:</b> <a href="#">foreignlogRecordSpecifier</a></p>
<a href="#">maintQualifier</a>	<p>Restricts the command based on the specified options.</p> <p><b>See Also:</b> <a href="#">maintQualifier</a></p>
<a href="#">recordSpec</a>	<p>Specifies the file that you are performing maintenance on.</p> <p>If you use the <b>BACKUPSET</b> parameter in <i>recordSpec</i>, then the keys identify backup sets for use with the <b>CHANGE</b>, <b>CROSSCHECK</b> and <b>DELETE</b> commands. For more details, see "<a href="#">LIST Command Output</a>" for an explanation of the column headings of the <b>LIST</b> output tables. Use the <b>KEY</b> column of the output to obtain the primary key usable in the <b>CHANGE</b> and <b>DELETE</b> commands.</p> <p><b>See Also:</b> <a href="#">recordSpec</a></p>
<b>DEVICE TYPE</b> <a href="#">deviceSpecifier</a>	<p>Allocates automatic channels for the specified device type only. This option is valid only if you have configured automatic channels and have not manually allocated channels. For example, if you configure automatic disk and tape channels and run <b>CROSSCHECK...DEVICE TYPE DISK</b>, then RMAN allocates only disk channels.</p> <p><b>See Also:</b> <a href="#">deviceSpecifier</a></p>

## Examples

### Example 4-32 Crosschecking Backups

The following command crosschecks backups of archived redo log files:

```
RMAN> CROSSCHECK BACKUP OF ARCHIVELOG ALL;

allocated channel: ORA_SBT_TAPE_1
channel ORA_SBT_TAPE_1: SID=103 device type=SBT_TAPE
channel ORA_SBT_TAPE_1: Oracle Secure Backup
using channel ORA_DISK_1
crosschecked backup piece: found to be 'AVAILABLE'
```

```

backup piece handle=8cic4031_1_1 RECID=195 STAMP=616693857
crosschecked backup piece: found to be 'AVAILABLE'
backup piece handle=8oic41ad_1_1 RECID=198 STAMP=616695118
crosschecked backup piece: found to be 'AVAILABLE'
backup piece handle=8qic41c3_1_1 RECID=200 STAMP=616695171
Crosschecked 3 objects

```

## 4.17 obsOperandList

### Purpose

Use the *obsOperandList* subclause used to specify which criteria are used to mark backups as obsolete.

### Usage Notes

Using both RECOVERY WINDOW and REDUNDANCY in a single REPORT OBSOLETE or DELETE OBSOLETE command is not supported.

### Syntax

**obsOperandList::=**

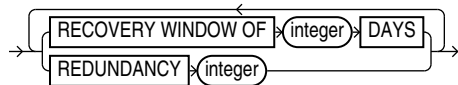

### Semantics

**obsOperandList**

Syntax Element	Description
RECOVERY WINDOW OF <i>integer</i> DAYS	Reports as obsolete those backup sets and image copies that are not needed to recover the database to any point within the last <i>integer</i> days. <b>See Also:</b> <a href="#">CONFIGURE</a> for an explanation of the recovery window
REDUNDANCY <i>integer</i>	Specifies the minimum level of redundancy considered necessary for a backup set or image copy to be obsolete. A data file copy is obsolete if there are at least <i>integer</i> more recent backup sets or image copies of this file; a data file backup set is obsolete if there are at least <i>integer</i> more recent backup sets or image copies of each data file contained in the backup set. For example, REDUNDANCY 2 means that there must be at least two more recent backup sets or image copies of a data file for any other backup set or image copy to be obsolete.

### Example

#### Example 4-33 Deleting Obsolete Backups

The following command deletes all backups and copies not needed to recover the database to an SCN within the last 30 days:

```
DELETE OBSOLETE RECOVERY WINDOW OF 30 DAYS;
```

## 4.18 recordSpec

### Purpose

Use the *recordSpec* subclause to specify which backups or copies the **CHANGE**, **CROSSCHECK**, **DELETE**, and **LIST** commands process.

Most *recordSpec* options allow you to specify a primary key. Use the output of the **LIST** command to obtain primary keys.

### Syntax

**recordSpec**::=

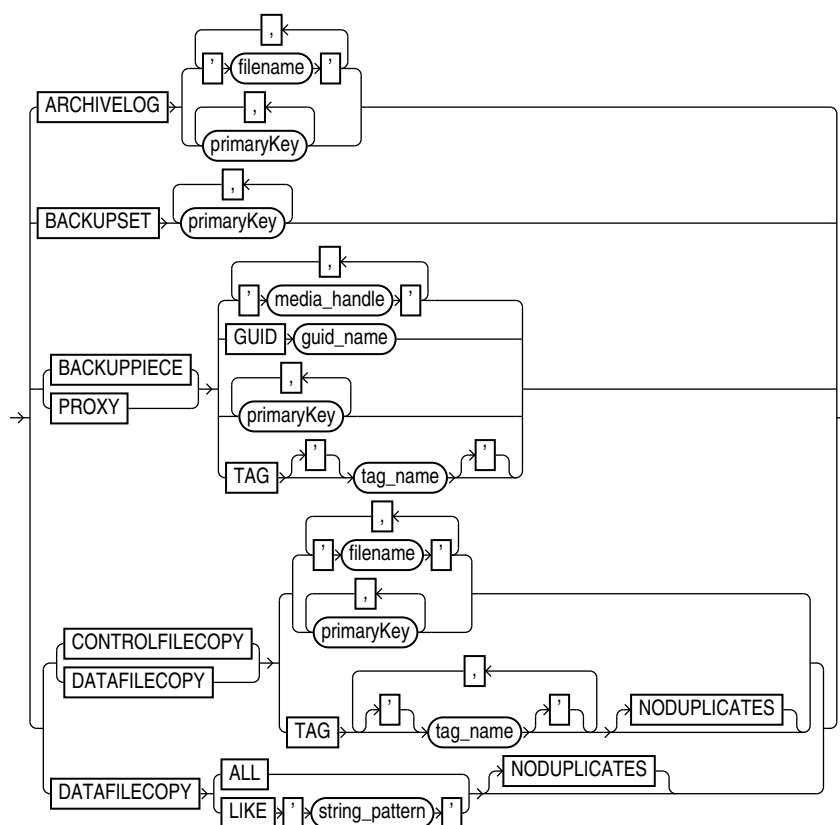

### Semantics

Syntax Element	Description
ARCHIVELOG	Specifies an archived redo log by either primary key or file name.
BACKUPSET	Specifies a backup set by primary key.
BACKUPPIECE	Specifies a backup piece by media handle, primary key, or tag name. Use <b>GUID</b> to specify the globally unique identifier (GUID) of the PDB for which the action must be performed.

Syntax Element	Description
PROXY	Specifies a proxy copy by media handle, primary key, or tag name.
CONTROLFILECOPY	Specifies a control file copy by primary key, file name pattern ('filename'), or TAG tag_name. If you crosscheck a control file copy, then you must specify a file name rather than a primary key.
DATAFILECOPY	Specifies a data file copy by primary key, file name pattern ('filename'), tag (TAG tag_name), or matching string (LIKE 'string_pattern'). Specify ALL to indicate all data file copies recorded in the RMAN repository.
NODUPLICATES	Targets only one copy of the control file or data file copy for the operation, even when there are multiple copies.

## Examples

### Example 4-34 Crosschecking Backups

This example crosschecks backup sets specified by primary key:

```
RMAN> LIST BACKUP SUMMARY;
```

```
List of Backups
```

```
=====
```

Key	TY	LV	S	Device	Type	Completion	Time	#Pieces	#Copies	Compressed	Tag
8504	B	A	A	SBT_TAPE		08-MAR-13		1	1	NO	TAG20130308T155057
8558	B	F	A	SBT_TAPE		08-MAR-13		1	1	NO	TAG20130308T155114
9872	B	F	A	DISK		08-MAR-13		1	1	NO	TAG20130308T160830
9954	B	A	A	SBT_TAPE		08-MAR-13		1	1	NO	TAG20130308T161157
9972	B	F	A	SBT_TAPE		08-MAR-13		1	1	NO	TAG20130308T161224
10021	B	A	A	SBT_TAPE		08-MAR-13		1	1	NO	TAG20130308T161251
10042	B	F	A	SBT_TAPE		08-MAR-13		1	1	NO	TAG20130308T161308
10185	B	F	A	DISK		08-MAR-13		1	1	NO	TAG20130308T170532
10210	B	F	A	DISK		08-MAR-13		1	1	NO	TAG20130308T170535

```
RMAN> CROSSCHECK BACKUPSET 9872, 10185, 10210;
```

```
allocated channel: ORA_SBT_TAPE_1
```

```
channel ORA_SBT_TAPE_1: SID=103 device type=SBT_TAPE
```

```
channel ORA_SBT_TAPE_1: Oracle Secure Backup
```

```
using channel ORA_DISK_1
```

```
crosschecked backup piece: found to be 'AVAILABLE'
```

```
backup piece handle=/disk2/PROD/autobackup/2013_03_08/o1_mf_s_616694910_2z19d0wg_.bkp RECID=197 STAMP=616694912
```

```
crosschecked backup piece: found to be 'AVAILABLE'
```

```
backup piece handle=/disk2/PROD/backupset/2013_03_08/o1_mf_nnsnf_TAG20130308T170532_2z1dpwz6_.bkp RECID=202 STAMP=616698332
```

```
crosschecked backup piece: found to be 'AVAILABLE'
```

```
backup piece handle=/disk2/PROD/autobackup/2013_03_08/o1_mf_s_616698335_2z1dq0d0_.bkp RECID=203 STAMP=616698336
```

```
Crosschecked 3 objects
```

### Example 4-35 Deleting Data File Copies

This example deletes the specified data file copy:

```
RMAN> DELETE NOPROMPT DATAFILECOPY '/disk1/oradata/prod/users01.dbf';
```



## 4.19 sizeSpec

### Purpose

The *sizeSpec* subclause specifies the size of the data.

### Syntax

**sizeSpec::=**

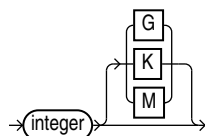

### Semantics

Syntax Element	Description
<i>integer</i> [G   K   M]	Specifies the size of data in gigabytes (G), kilobytes (K), or megabytes (M).

### Examples

#### Example 4-36 Setting the Maximum Size of a Backup Piece

This `ALLOCATE` command specifies in the `MAXPIECESIZE` parameter that no backup piece written to tape can exceed 800 MB.

```

RUN
{
  ALLOCATE CHANNEL c1 DEVICE TYPE sbt
    PARMS 'SBT_LIBRARY=/usr/local/oracle/backup/lib/libobk.so,
    ENV=(OB_DEVICE_1=stapel) '
    MAXPIECESIZE 800M;
}

```

## 4.20 tempfileSpec

### Purpose

Use the *tempfileSpec* subclause to specify a temp file by name or absolute file number.

### Syntax

**tempfileSpec::=**

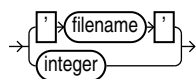

## Semantics

Syntax Element	Description
<code>'filename'</code>	Specifies the data file by using either the full path or a relative file name. If you specify a relative file name, the file name is qualified in a platform-specific manner by the target database.  You can specify an absolute path name, or a path name relative to the Oracle home. Double and single quotes are both valid (although only single quotes are shown in the diagram). Use a question mark (?) to represent the Oracle home and the at sign (@) for the Oracle SID.
<code>integer</code>	Specifies the data file by absolute file number. Obtain the file number from the <code>V\$TEMPFILE</code> view or <a href="#">REPORT SCHEMA</a> output.

## Examples

**Example 4-37 Specifying a Temp File by File Name**

This example renames temp file `/disk1/oradata/prod/temp01.dbf` to `/disk2/temp01.dbf`, specifying it by file name. The database must be mounted when performing this example.

```
SHUTDOWN IMMEDIATE
STARTUP MOUNT
RUN
{
  SWITCH TEMPFILE '/disk1/oradata/prod/temp01.dbf'
                  TO '/disk2/temp01.dbf';
}
ALTER DATABASE OPEN;
```

## 4.21 toDestSpec

## Purpose

Use the `toDestSpec` subclause to specify a directory or an Automatic Storage Management disk group for disk backups. If you do not specify a value for the `TO DESTINATION`, then RMAN either creates the backup in the fast recovery area if it is enabled, or in a platform-specific directory (for example, `*/dbs` on UNIX) if a fast recovery area is not enabled. RMAN uses Oracle Managed Files file names when the `TO DESTINATION` parameter is used.

## Usage Notes

This subclause can only be used with disk devices and cannot be used with the `FORMAT` option.

If backup optimization is enabled, RMAN only skips backups of files that have identical backups in the location designated by the `TO DESTINATION` field.

You can specify up to four `TO DESTINATION` strings. RMAN uses the second, third, and fourth values only when `BACKUP COPIES`, `SET BACKUP COPIES`, or `CONFIGURE . . . BACKUP COPIES` is in effect. When choosing the format for each backup piece, RMAN uses the first format value for copy 1, the second format value for copy 2, and so on. If the number of format values exceeds the number of copies, then the extra formats are not used. If the number of format values is less than the number of copies, then RMAN reuses the format values, starting with the first one.

Specify *toDest\_string* in any of the following places, listed in order of precedence:

1. The `backupSpec` clause
2. The `BACKUP` command
3. The `ALLOCATE CHANNEL` command
4. The `CONFIGURE CHANNEL` command

If it is specified in multiple places, then RMAN searches for the `TO DESTINATION` parameter in the order shown.

### Syntax

***toDestSpec*::=**

→ `'(toDest_string)'`

### Examples

#### Example 4-38 Specifying an ASM Disk Group

This example copies the database to ASM disk group `DISK1`:

```
BACKUP AS COPY DATABASE TO DESTINATION '+DISK1';
```

#### Example 4-39 Specifying a Destination for Data File Copies

This example copies two data files with tag `LATESTCOPY` to directory `/disk2`:

```
BACKUP AS COPY
  COPY OF DATAFILE 27, 28
  FROM TAG 'LATESTCOPY' TO DESTINATION '/disk2';
```

#### Example 4-40 Specifying a Destination for Recovery Area files

This example copies all recovery area files to `/disk2`:

Because Backup Recovery Area has backup optimization enabled by default, RMAN only skips backups of files that previously exist on `/disk2` and not ones that reside in other locations.

**Note:** This subclause, when used with the `BACKUP RECOVERY AREA`, enables you to designate a disk channel as a location.

```
BACKUP RECOVERY AREA TO DESTINATION '/disk2';
```

## 4.22 untilClause

### Purpose

Use the *untilClause* subclause to specify an upper limit by time, SCN, or log sequence number for various RMAN operations.

### Usage Notes

To specify a restore point, use the `TO RESTORE POINT` clause. See "SET" for an example.

## Syntax

**untilClause ::=**

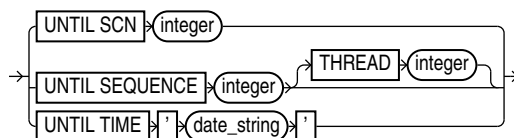

## Semantics

Syntax Element	Description
UNTIL SCN <i>integer</i>	Specifies an SCN as an upper, noninclusive limit. RMAN selects only files that it can use to restore or recover up to but not including the specified SCN (see <a href="#">Example 4-41</a> ). For example, <code>RESTORE DATABASE UNTIL SCN 1000</code> chooses only backups that could be used to recover to SCN 1000.
UNTIL SEQUENCE <i>integer</i>	Specifies a redo log sequence number and thread as an upper, noninclusive limit. RMAN selects only files that it can use to restore or recover up to but not including the specified sequence number. For example, <code>REPORT OBSOLETE UNTIL SEQUENCE 8000</code> reports only backups that could be used to recover through log sequence 7999.
THREAD <i>integer</i>	Specifies the number of the redo thread.
UNTIL TIME ' <i>date_string</i> '	Specifies a time as an upper, noninclusive limit (see <a href="#">Example 4-42</a> ). RMAN selects only files that it can use to restore and recover up to but not including the specified time. For example, <code>LIST BACKUP UNTIL TIME 'SYSDATE-7'</code> lists all backups that could be used to recover to a point one week ago. When specifying dates in RMAN commands, the date string must be either: <ul style="list-style-type: none"> <li>A literal string whose format matches the <code>NLS_DATE_FORMAT</code> setting.</li> <li>A SQL expression of type <code>DATE</code>, for example, <code>'SYSDATE-10'</code> or <code>"TO_DATE('01/30/2013', 'MM/DD/YYYY')"</code>. The second example includes its own date format mask and so is independent of the current <code>NLS_DATE_FORMAT</code> setting.</li> </ul> Following are examples of typical date settings in RMAN commands: <pre> BACKUP ARCHIVELOG FROM TIME 'SYSDATE-31' UNTIL TIME 'SYSDATE-14'; RESTORE DATABASE UNTIL TIME "TO_DATE('09/20/06', 'MM/DD/YY')";           </pre> <p><b>Note:</b> The granularity of time-based recovery is dependent on time stamps in the redo log. For example, suppose that you specify the following command:</p> <pre> RECOVER DATABASE UNTIL TIME '2013-07-26 17:45:00';           </pre> If no redo was written with a time stamp of 17:45:00, then recovery proceeds until it finds the next redo time stamp that is higher. For example, the next redo time stamp may be 17:45:04. You can check for the nearest time for a specific SCN by querying the <code>FIRST_TIME</code> and <code>FIRST_CHANGE#</code> columns in <code>V\$LOG_HISTORY</code> TABLE.

## Examples

### Example 4-41 Performing Incomplete Recovery to a Specified SCN

This example, which assumes a mounted database, recovers the database up to (but not including) the specified SCN:

```
STARTUP FORCE MOUNT
RUN
{
  SET UNTIL SCN 1418901; # set to 1418901 to recover database through SCN
1418900
  RESTORE DATABASE;
  RECOVER DATABASE;
}
ALTER DATABASE OPEN RESETLOGS;
```

### Example 4-42 Reporting Obsolete Backups

This example assumes that you want to be able to recover to any point within the last week. It considers as obsolete all backups that could be used to recover the database to a point one week ago:

```
REPORT OBSOLETE UNTIL TIME 'SYSDATE-7';
```

# 5

## Recovery Catalog Views

This chapter contains descriptions of recovery catalog views. You can only access these views if you have created a recovery catalog (see [CREATE CATALOG](#)). For a summary of the recovery catalog views, refer to "[Summary of RMAN Recovery Catalog Views](#)".

### Note:

These views are not normalized, but are optimized for RMAN and Enterprise Manager usage. Hence, most catalog views have redundant values that result from joining of several underlying tables.

The views intended for use by Enterprise Manager are generally less useful for direct querying than the other views.

### 5.1 Summary of RMAN Recovery Catalog Views

RMAN recovery catalog views store information about backups of all databases that are registered with the recovery catalog.

### Note:

A multitenant container database is the only supported architecture in Oracle Database 21c. While the documentation is being revised, legacy terminology may persist. In most cases, "database" and "non-CDB" refer to a CDB or PDB, depending on context. In some contexts, such as upgrades, "non-CDB" refers to a non-CDB from a previous release.

The following table provides a functional summary of RMAN recovery catalog views.

### Note:

The data type of some recovery catalog view columns is listed as `VARCHAR2(4000)`. This length for `VARCHAR2` columns is applicable when the initialization parameter `VARCHAR2_MAX_SIZE` is set to `LEGACY`. If you set the value of `VARCHAR2_MAX_SIZE` to `32767`, the columns with data type listed as `VARCHAR2(4000)` will be `VARCHAR2(32767)`.

**Table 5-1 Recovery Catalog Views**

Recovery Catalog View	Corresponding V\$ View	Catalog View Description
<a href="#">RC_ARCHIVED_LOG</a>	V\$ARCHIVED_LOG	Archived and unarchived redo log files
<a href="#">RC_BACKUP_ARCHIVELOG_DETAILS</a>	V\$BACKUP_ARCHIVELOG_DETAILS	Details about archived redo log backups for Enterprise Manager
<a href="#">RC_BACKUP_ARCHIVELOG_SUMMARY</a>	V\$BACKUP_ARCHIVELOG_SUMMARY	Summary of information about archived redo log backups for Enterprise Manager
<a href="#">RC_BACKUP_CONTROLFILE</a>	V\$BACKUP_DATAFILE	Control files backed up in backup sets
<a href="#">RC_BACKUP_CONTROLFILE_DETAILS</a>	V\$BACKUP_CONTROLFILE_DETAILS	Details about control file backups for Enterprise Manager
<a href="#">RC_BACKUP_CONTROLFILE_SUMMARY</a>	V\$BACKUP_CONTROLFILE_SUMMARY	Summary of information about control file backups for Enterprise Manager
<a href="#">RC_BACKUP_COPY_DETAILS</a>	V\$BACKUP_COPY_DETAILS	Details about data file image copy backups for Enterprise Manager
<a href="#">RC_BACKUP_COPY_SUMMARY</a>	V\$BACKUP_COPY_SUMMARY	Summary of information about data file image copy backups for Enterprise Manager
<a href="#">RC_BACKUP_CORRUPTION</a>	V\$BACKUP_CORRUPTION	Corrupt block ranges in data file backups
<a href="#">RC_BACKUP_DATAFILE</a>	V\$BACKUP_DATAFILE	Data files in backup sets
<a href="#">RC_BACKUP_DATAFILE_DETAILS</a>	V\$BACKUP_DATAFILE_DETAILS	Details about data file backups for Enterprise Manager
<a href="#">RC_BACKUP_DATAFILE_SUMMARY</a>	V\$BACKUP_DATAFILE_SUMMARY	Summary of information about data file backups for Enterprise Manager
<a href="#">RC_BACKUP_FILES</a>	V\$BACKUP_FILES	RMAN backups and copies known to the repository.
<a href="#">RC_BACKUP_PIECE</a>	V\$BACKUP_PIECE	Backup pieces
<a href="#">RC_BACKUP_PIECE_DETAILS</a>	V\$BACKUP_PIECE_DETAILS	Details about backup pieces for Enterprise Manager
<a href="#">RC_BACKUP_REDOLOG</a>	V\$BACKUP_REDOLOG	Archived redo log files in backup sets
<a href="#">RC_BACKUP_SET</a>	V\$BACKUP_SET	Backup sets for all incarnations of databases registered in the catalog
<a href="#">RC_BACKUP_SET_DETAILS</a>	V\$BACKUP_SET_DETAILS	Details about backup sets for Enterprise Manager
<a href="#">RC_BACKUP_SET_SUMMARY</a>	V\$BACKUP_SET_SUMMARY	Summary of information about backup sets for Enterprise Manager
<a href="#">RC_BACKUP_SPFILE</a>	V\$BACKUP_SPFILE	Server parameter files in backups
<a href="#">RC_BACKUP_SPFILE_DETAILS</a>	V\$BACKUP_SPFILE_DETAILS	Details about server parameter file backups for Enterprise Manager
<a href="#">RC_BACKUP_SPFILE_SUMMARY</a>	V\$BACKUP_SPFILE_SUMMARY	Summary of information about server parameter file backups for Enterprise Manager

**Table 5-1 (Cont.) Recovery Catalog Views**

Recovery Catalog View	Corresponding V\$ View	Catalog View Description
<a href="#">RC_CHECKPOINT</a>	n/a	Deprecated in favor of <a href="#">RC_RESYNC</a>
<a href="#">RC_CONTROLFILE_COPY</a>	V\$DATAFILE_COPY	Control file copies on disk
<a href="#">RC_COPY_CORRUPTION</a>	V\$COPY_CORRUPTION	Corrupt block ranges in data file copies
<a href="#">RC_DATABASE</a>	V\$DATABASE	Databases registered in the recovery catalog
<a href="#">RC_DATABASE_BLOCK_CORRUPTION</a>	V\$DATABASE_BLOCK_CORRUPTION	Database blocks marked as corrupted in the most recent RMAN backup or copy
<a href="#">RC_DATABASE_INCARNATION</a>	V\$DATABASE_INCARNATION	Database incarnations registered in the recovery catalog
<a href="#">RC_DATAFILE</a>	V\$DATAFILE	Data files registered in the recovery catalog
<a href="#">RC_DATAFILE_COPY</a>	V\$DATAFILE_COPY	Data file copies on disk
<a href="#">RC_DISK_RESTORE_RANGE</a>	V\$DISK_RESTORE_RANGE	Details about the restore range of the database for backup data stored on disk
<a href="#">RC_LOG_HISTORY</a>	V\$LOG_HISTORY	Online redo log history indicating when log switches occurred
<a href="#">RC_OFFLINE_RANGE</a>	V\$OFFLINE_RANGE	Offline ranges for data files
<a href="#">RC_PDBS</a>	V\$PDBS	Pluggable databases (PDBs) registered in the recovery catalog
<a href="#">RC_PLUGGABLE_DATABASE_INC</a>	V\$PDB_INCARNATION	PDB incarnations registered in the recovery catalog
<a href="#">RC_PROXY_ARCHIVEDLOG</a>	V\$PROXY_ARCHIVEDLOG	Archived log backups taken with the proxy copy functionality
<a href="#">RC_PROXY_ARCHIVELOG_DETAILS</a>	V\$PROXY_ARCHIVELOG_DETAILS	Details about proxy archived redo log files for Enterprise Manager
<a href="#">RC_PROXY_ARCHIVELOG_SUMMARY</a>	V\$PROXY_ARCHIVELOG_SUMMARY	Summary of information about proxy archived redo log files for Enterprise Manager
<a href="#">RC_PROXY_CONTROLFILE</a>	V\$PROXY_DATAFILE	Control file backups taken with the proxy copy functionality
<a href="#">RC_PROXY_COPY_DETAILS</a>	V\$PROXY_COPY_DETAILS	Details about data file proxy copies for Enterprise Manager
<a href="#">RC_PROXY_COPY_SUMMARY</a>	V\$PROXY_COPY_SUMMARY	Summary of information about data file proxy copies for Enterprise Manager
<a href="#">RC_PROXY_DATAFILE</a>	V\$PROXY_DATAFILE	Data file backups that were taken using the proxy copy functionality
<a href="#">RC_REDO_LOG</a>	V\$LOG and V\$LOGFILE	Online redo logs for all incarnations of the database since the last catalog resynchronization



Table 5-1 (Cont.) Recovery Catalog Views

Recovery Catalog View	Corresponding V\$ View	Catalog View Description
RC_REDO_THREAD	V\$THREAD	All redo threads for all incarnations of the database since the last catalog resynchronization
RC_RESTORE_POINT	V\$RESTORE_POINT	All restore points for all incarnations of the database since the last catalog resynchronization
RC_RESTORE_RANGE	V\$RESTORE_RANGE	Details about the restore range of databases registered in the recovery catalog
RC_RESYNC	n/a	Recovery catalog resynchronizations
RC_RMAN_BACKUP_JOB_DETAILS	V\$RMAN_BACKUP_JOB_DETAILS	Details about backup jobs for Enterprise Manager
RC_RMAN_BACKUP_SUBJOB_DETAILS	V\$RMAN_BACKUP_SUBJOB_DETAILS	Details about backup subjobs for Enterprise Manager
RC_RMAN_BACKUP_TYPE	V\$RMAN_BACKUP_TYPE	Used internally by Enterprise Manager
RC_RMAN_CONFIGURATION	V\$RMAN_CONFIGURATION	RMAN configuration settings
RC_RMAN_OUTPUT	V\$RMAN_OUTPUT	Output from RMAN commands for use in Enterprise Manager
RC_RMAN_STATUS	V\$RMAN_STATUS	Historical status information about RMAN operations.
RC_SBT_RESTORE_RANGE	V\$SBT_RESTORE_RANGE	Details about the restore range of the database for backup data stored on tape
RC_SITE	n/a	Databases in a Data Guard environment
RC_STORED_SCRIPT	n/a	Names of scripts stored in the recovery catalog
RC_STORED_SCRIPT_LINE	n/a	Contents of the scripts stored in the recovery catalog
RC_TABLESPACE	V\$TABLESPACE	All tablespaces registered in the recovery catalog, all dropped tablespaces, and tablespaces that belong to old incarnations
RC_TEMPFILE	V\$TEMPFILE	All temp files registered in the recovery catalog
RC_UNUSABLE_BACKUPFILE_DETAILS	V\$UNUSABLE_BACKUPFILE_DETAILS	Unusable backup files registered in the recovery catalog

## 5.2 RC\_ARCHIVED\_LOG

This view contains historical information about archived and unarchived redo log files. It corresponds to the V\$ARCHIVED\_LOG view in the target database control file.

Oracle inserts an archived redo log record after the online redo log is successfully archived. If a log that has not been archived is cleared, then a record is inserted with

the `NAME` column set to `NULL`. If the log is archived multiple times, then the view contains multiple archived log records with the same `THREAD#`, `SEQUENCE#`, and `RESETLOGS_CHANGE#`, but with a different name.

An archived log record is also inserted when an archived log is restored from a backup set or a copy. An archived log can have no record if the record ages out of the control file.

Column	Data Type	Description
<code>DB_KEY</code>	NUMBER	The primary key for this database in the recovery catalog. Use this column to join with almost any other catalog view.
<code>DBINC_KEY</code>	NUMBER	The primary key for the incarnation of the target database to which this record belongs. Use this column to join with <code>RC_DATABASE_INCARNATION</code> .
<code>DB_NAME</code>	VARCHAR2 (8)	The <code>DB_NAME</code> of the database incarnation to which this record belongs.
<code>AL_KEY</code>	NUMBER	The primary key of the archived redo log in the recovery catalog. If you issue the <code>LIST</code> command while <code>RMAN</code> is connected to the recovery catalog, then this value appears in the <code>KEY</code> column of the output.
<code>RECID</code>	NUMBER	The archived redo log <code>RECID</code> from <code>V\$ARCHIVED_LOG</code> . <code>RECID</code> and <code>STAMP</code> form a concatenated primary key that uniquely identifies this record in the target database control file.
<code>STAMP</code>	NUMBER	The archived redo log stamp from <code>V\$ARCHIVED_LOG</code> . <code>RECID</code> and <code>STAMP</code> form a concatenated primary key that uniquely identifies this record in the target database control file.
<code>NAME</code>	VARCHAR2 (1024)	The file name of the archived redo log.
<code>THREAD#</code>	NUMBER	The number of the redo thread.
<code>SEQUENCE#</code>	NUMBER	The log sequence number.
<code>RESETLOGS_CHANGE#</code>	NUMBER	The <code>SCN</code> of the most recent <code>RESETLOGS</code> when the record was created.
<code>RESETLOGS_TIME</code>	DATE	The time stamp of the most recent <code>RESETLOGS</code> when the record was created.
<code>FIRST_CHANGE#</code>	NUMBER	The first <code>SCN</code> of this redo log.
<code>FIRST_TIME</code>	DATE	The time when Oracle switched into the redo log.
<code>NEXT_CHANGE#</code>	NUMBER	The first <code>SCN</code> of the next redo log in the thread.
<code>NEXT_TIME</code>	DATE	The first time stamp of the next redo log in the thread.
<code>BLOCKS</code>	NUMBER	The size of this archived log in operating system blocks.
<code>BLOCK_SIZE</code>	NUMBER	The size of the block in bytes.
<code>COMPLETION_TIME</code>	DATE	The time when the redo log was archived or copied.

Column	Data Type	Description
ARCHIVED	VARCHAR2 (3)	Indicates whether the log was archived: YES (archived redo log) or NO (inspected file header of online redo log and added record to V\$ARCHIVED_LOG). Inspecting the online logs creates archived log records for them, which allows them to be applied during RMAN recovery. Oracle sets ARCHIVED to NO to prevent online logs from being backed up.
STATUS	VARCHAR2 (1)	The status of the archived redo log: A (available), U (unavailable), D (deleted), or X (expired).
IS_STANDBY	VARCHAR2 (3)	The database that archived this log: Y (belongs to a standby database) or N (belongs to the primary database).
DICTIONARY_BEGIN	VARCHAR2 (3)	Indicates whether this archived log contains the start of a LogMiner dictionary: YES or NO. If both DICTIONARY_BEGIN and DICTIONARY_END are YES, then this log contains a complete LogMiner dictionary. If DICTIONARY_BEGIN is YES but DICTIONARY_END is NO, this log contains the start of the dictionary, and it continues through each subsequent log of this thread and ends in the log where DICTIONARY_END is YES.
DICTIONARY_END	VARCHAR2 (3)	Indicates whether this archived log contains the end of a LogMiner dictionary: YES or NO. See the description of DICTIONARY_BEGIN for an explanation of how to interpret this value.
IS_RECOVERY_DEST_FILE	VARCHAR2 (3)	This copy is located in the fast recovery area: YES or NO.
COMPRESSED	VARCHAR2 (3)	Internal only
CREATOR	VARCHAR2 (7)	Creator of the archived redo log: <ul style="list-style-type: none"> <li>ARCH - Archiver process</li> <li>FGRD - Foreground process</li> <li>RMAN - Recovery Manager</li> <li>SRMN - RMAN at standby</li> <li>LGWR - Log Writer process</li> </ul>
TERMINAL	VARCHAR2 (3)	Indicates whether this log was created during terminal recovery of a standby database. Values are YES or NO.
SITE_KEY	NUMBER	Primary key of the Data Guard database associated with this file. Each database in a Data Guard environment has a unique SITE_KEY value. You can use SITE_KEY in a join with the RC_SITE view to obtain the DB_UNIQUE_NAME of the database.

## 5.3 RC\_BACKUP\_ARCHIVELOG\_DETAILS

RC\_BACKUP\_ARCHIVELOG\_DETAILS provides detailed information about backups of archived redo log files.

This view is primarily intended to be used internally by Enterprise Manager.

Column	Data Type	Description
BTYPE	CHAR (9)	The backup type container, which can be BACKUPSET, IMAGECOPY, or PROXYCOPY.
BTYPE_KEY	NUMBER	A unique identifier for the backup type. For backup sets, it is VS_KEY; for image copies, it is COPY_KEY; for proxy copies it is XAL_KEY.
SESSION_KEY	NUMBER	Unique identifier for this session. Use for joins with RC_RMAN_BACKUP_JOB_DETAILS.
SESSION_RECID	NUMBER	The RECID from the control file for the target database which corresponds to this RMAN session.
SESSION_STAMP	NUMBER	The STAMP from the control file for the target database which corresponds to this RMAN session.
DB_KEY	NUMBER	The primary key for this database in the recovery catalog. Use this column to join with almost any other catalog view.
DB_NAME	VARCHAR2 (8)	The DB_NAME of the database incarnation to which this record belongs.
ID1	NUMBER	For archived logs in backup sets, this column contains SET_STAMP. For proxy copy or image copy backups, this column contains the RECID from the control file.
ID2	NUMBER	For archived logs in backup sets, this column contains SET_COUNT. For image copy or proxy copy backups, this column contains STAMP.
THREAD#	NUMBER	Thread number of this archived redo log file.
SEQUENCE#	NUMBER	Sequence number of this archived redo log file.
RESETLOGS_CHANGE#	NUMBER	SCN of OPEN RESETLOGS branch for this archived log.
RESETLOGS_TIME	DATE	Time of OPEN RESETLOGS branch for this archived log.
FIRST_CHANGE#	NUMBER	Starting SCN for this archived log file.
FIRST_TIME	DATE	Time corresponding to starting SCN for this archived redo log file.
NEXT_CHANGE#	NUMBER	Ending SCN for this archived redo log file.
NEXT_TIME	DATE	Time corresponding to the ending SCN for this archived redo log file.
FILESIZE	NUMBER	Size of backed up redo log file, in bytes.
COMPRESSION_RATIO	NUMBER	Compression ratio for this backup.
FILESIZE_DISPLAY	VARCHAR2 (32K)	Same value as FILESIZE, but converted to a user-displayable format, for example, 798.01M or 5.25G.

## 5.4 RC\_BACKUP\_ARCHIVELOG\_SUMMARY

RC\_BACKUP\_ARCHIVELOG\_SUMMARY summarizes the backup of archived redo log files for a single or for multiple RMAN jobs.

This view is primarily intended to be used internally by Enterprise Manager.

Column	Data Type	Description
DB_NAME	VARCHAR2 (8)	The DB_NAME of the database incarnation to which this record belongs.
DB_KEY	NUMBER	The primary key for this database in the recovery catalog. Use this column to join with almost any other catalog view.
NUM_FILES_BACKED	NUMBER	The number of archived redo log files backed up. If an archived log is included in more than one backup job, then RMAN counts each backup separately.  For example, if the view summarizes two RMAN backup jobs, each of which backs up only archived log 1000, then the value of this column is 2 and the value of NUM_DISTINCT_FILES_BACKED is 1.
NUM_DISTINCT_FILES_BACKED	NUMBER	The number of distinct archived redo log files backed up, where files are distinguished by unique log sequence number, thread number, and RESETLOGS branch.  For example, if the view summarizes two RMAN backup jobs, each of which backs up only archived log 1000, then the value of this column is 1 and the value of NUM_FILES_BACKED is 2.
MIN_FIRST_CHANGE#	NUMBER	The lowest SCN in the range of archived redo log files that have been backed up.
MAX_NEXT_CHANGE#	NUMBER	The highest SCN in the range of archived redo log files that have been backed up.
MIN_FIRST_TIME	DATE	The earliest point in time covered by the archived redo log files that have been backed up.
MAX_NEXT_TIME	DATE	The latest point in time covered by the archived redo log files that have been backed up.
INPUT_BYTES	NUMBER	The total size in bytes of all archived redo log files that have been backed up.
OUTPUT_BYTES	NUMBER	Sum of sizes of all output pieces generated by this job.
COMPRESSION_RATIO	NUMBER	Compression ratio for this backup.
INPUT_BYTES_DISPLAY	VARCHAR2 (32K)	Same value as INPUT_BYTES, but converted to a user-displayable format, for example nM, nG, nT, nP.
OUTPUT_BYTES_DISPLAY	VARCHAR2 (32K)	Same value as OUTPUT_BYTES, but converted to a user-displayable format, for example, 798.01M or 5.25G.

## 5.5 RC\_BACKUP\_CONTROLFILE

This view lists information about control files in backup sets.

The `V$BACKUP_DATAFILE` view contains both data file and control file records: a backup data file record with file number 0 represents the backup control file. In the recovery catalog, the `RC_BACKUP_CONTROLFILE` view contains only control file records, while the `RC_BACKUP_DATAFILE` view contains only data file records.

Column	Data Type	Description
DB_KEY	NUMBER	The primary key for this database in the recovery catalog. Use this column to join with almost any other catalog view.
DBINC_KEY	NUMBER	The primary key for the incarnation of the target database. Use this column to join with <code>RC_DATABASE_INCARNATION</code> .
DB_NAME	VARCHAR2 (8)	The <code>DB_NAME</code> of the database incarnation to which this record belongs.
BCF_KEY	NUMBER	The primary key of the control file backup in the recovery catalog. If you issue the <code>LIST</code> command while <code>RMAN</code> is connected to the recovery catalog, then this value appears in the <code>KEY</code> column of the output.
RECID	NUMBER	The <code>RECID</code> value from <code>V\$BACKUP_DATAFILE</code> . <code>RECID</code> and <code>STAMP</code> form a concatenated primary key that uniquely identifies this record in the target database control file.
STAMP	NUMBER	The <code>STAMP</code> value from <code>V\$BACKUP_DATAFILE</code> . <code>RECID</code> and <code>STAMP</code> form a concatenated primary key that uniquely identifies this record in the target database control file.
BS_KEY	NUMBER	The primary key of the backup set to which this record belongs in the recovery catalog. Use this column to join with <code>RC_BACKUP_SET</code> or <code>RC_BACKUP_PIECE</code> .
SET_STAMP	NUMBER	The <code>SET_STAMP</code> value from <code>V\$BACKUP_SET</code> . <code>SET_STAMP</code> and <code>SET_COUNT</code> form a concatenated key that uniquely identifies the backup set to which this record belongs in the target database control file.
SET_COUNT	NUMBER	The <code>SET_COUNT</code> value from <code>V\$BACKUP_SET</code> . <code>SET_STAMP</code> and <code>SET_COUNT</code> form a concatenated key that uniquely identifies the backup set to which this record belongs in the target database control file.
RESETLOGS_CHANGE#	NUMBER	The SCN of the most recent <code>RESETLOGS</code> when the record was created.
RESETLOGS_TIME	DATE	The time stamp of the most recent <code>RESETLOGS</code> when the record was created.
CHECKPOINT_CHANGE#	NUMBER	The control file checkpoint SCN.

Column	Data Type	Description
CHECKPOINT_TIME	DATE	The control file checkpoint time.
CREATION_TIME	DATE	The control file creation time.
BLOCK_SIZE	NUMBER	The size of the blocks in bytes.
OLDEST_OFFLINE_RANGE	NUMBER	Internal use only.
STATUS	VARCHAR2 (1)	The status of the backup set: A (available), U (unavailable), or D (deleted).
BS_RECID	NUMBER	The control file <code>RECID</code> of the backup set that contains this backup control file.
BS_STAMP	NUMBER	The control file stamp of the backup set that contains this control file.
BS_LEVEL	NUMBER	The incremental level ( <code>NULL</code> , 0, 1) of the backup set that contains this backup control file. Although an incremental backup set can contain the control file, it is always contains a complete copy of the control file. There is no such thing as an incremental control file backup.
COMPLETION_TIME	DATE	The date that the control file backup completed.
CONTROLFILE_TYPE	VARCHAR2 (1)	The type of control file backup: B (normal backup) or S (standby backup).
BLOCKS	NUMBER	The number of blocks in the file.
AUTOBACKUP_DATE	DATE	The date of the control file autobackup.
AUTOBACKUP_SEQUENCE	NUMBER	The sequence of the control file autobackup: 1 - 255.

## 5.6 RC\_BACKUP\_CONTROLFILE\_DETAILS

`RC_BACKUP_CONTROLFILE_DETAILS` provides detailed information about control file backups that can be restored, including backups in control file image copies, backup sets, and proxy copies.

This view is primarily intended to be used internally by Enterprise Manager.

Column	Data Type	Description
BTYPE	CHAR (9)	The type of this control file backup. Possible values are <code>BACKUPSET</code> , <code>IMAGECOPY</code> or <code>PROXYCOPY</code> .
BTYPE_KEY	NUMBER	Unique identifier for the backup type. If <code>BTYPE</code> is <code>BACKUPSET</code> , then this value is the <code>BS_KEY</code> value for the backup set. If <code>BTYPE</code> is <code>IMAGECOPY</code> , this value is the value of <code>COPY_KEY</code> for the copy. If <code>BTYPE</code> is <code>PROXYCOPY</code> , this is the value of <code>XCF_KEY</code> for the proxy copy.
SESSION_KEY	NUMBER	Session identifier. Use in joins with <code>RC_RMAN_OUTPUT</code> and <code>RC_RMAN_BACKUP_JOB_DETAILS</code> .
SESSION_RECID	NUMBER	The <code>RECID</code> from the control file for the target database which corresponds to this RMAN session.

Column	Data Type	Description
SESSION_STAMP	NUMBER	The STAMP from the control file for the target database which corresponds to this RMAN session.
DB_KEY	NUMBER	The primary key for this database in the recovery catalog. Use this column to join with almost any other catalog view.
DB_NAME	VARCHAR2 (8)	The DB_NAME of the database incarnation to which this record belongs.
ID1	NUMBER	For backups taken as backup sets, this column contains SET_STAMP. For proxy copy or image copy backups, this column contains the RECID from the control file.
ID2	NUMBER	For backups taken as backup sets, this column contains SET_COUNT. For proxy copy or image copy backups, this column contains the value of STAMP.
CREATION_TIME	DATE	File creation time for the control file that was backed up.
RESETLOGS_CHANGE#	NUMBER	SCN of the RESETLOGS branch where this control file was backed up.
RESETLOGS_TIME	DATE	Time of the RESETLOGS branch where this control file was backed up.
CHECKPOINT_CHANGE#	NUMBER	Most recent checkpoint change SCN for the control file that was backed up.
CHECKPOINT_TIME	DATE	Most recent checkpoint time for the control file that was backed up.
FILESIZE	NUMBER	File size, in bytes, for the output of backing up this control file.
COMPRESSION_RATIO	NUMBER	Compression ratio for this backup.
FILESIZE_DISPLAY	VARCHAR2 (32K)	Same value as the FILESIZE column, but converted to a user-displayable format, for example, 798.01M or 5.25G.

## 5.7 RC\_BACKUP\_CONTROLFILE\_SUMMARY

RC\_BACKUP\_CONTROLFILE\_SUMMARY provides summary information about control file backups that can be restored, including backups in control file image copies, backup sets, and proxy copies.

This view is primarily intended to be used internally by Enterprise Manager.

Column	Data Type	Description
DB_NAME	VARCHAR2 (8)	The DB_NAME of the database incarnation to which this record belongs.
DB_KEY	NUMBER	The primary key for this database in the recovery catalog. Use this column to join with almost any other catalog view.



Column	Data Type	Description
NUM_FILES_BACKED	NUMBER	Total number of control file backups.
NUM_DISTINCT_FILES_BACKED	NUMBER	Number of distinct control files backed up.
MIN_CHECKPOINT_CHANGE#	NUMBER	Lowest checkpoint SCN among all backed up control files.
MAX_CHECKPOINT_CHANGE#	NUMBER	Highest checkpoint SCN among all backed up control files.
MIN_CHECKPOINT_TIME	DATE	Earliest checkpoint time of any control file in the summary.
MAX_CHECKPOINT_TIME	DATE	Latest checkpoint time of any control file in the summary.
INPUT_BYTES	NUMBER	Total size of input files, in bytes.
OUTPUT_BYTES	NUMBER	Sum of sizes of all output pieces generated by this job.
COMPRESSION_RATIO	NUMBER	Compression ratio for this backup.
INPUT_BYTES_DISPLAY	VARCHAR2 (32K)	Same value as INPUT_BYTES, but converted to a user-displayable format, for example, 798.01M or 5.25G.
OUTPUT_BYTES_DISPLAY	VARCHAR2 (32K)	Same value as OUTPUT_BYTES, but converted to a user-displayable format, for example, 798.01M or 5.25G.

## 5.8 RC\_BACKUP\_COPY\_DETAILS

RC\_BACKUP\_COPY\_DETAILS contains detailed information all AVAILABLE control file and data file copies.

Columns SESSION\_KEY, SESSION\_RECID, SESSION\_STAMP, and COPY\_KEY uniquely identify an RMAN session and data file copy. Other columns for this view have the same semantics as in RC\_DATAFILE\_COPY. This view is primarily intended to be used internally by Enterprise Manager.

Column	Data Type	Description
SESSION_KEY	NUMBER	Session identifier. Use in joins with RC_RMAN_OUTPUT and RC_RMAN_BACKUP_JOB_DETAILS.
SESSION_RECID	NUMBER	With SESSION_STAMP, uniquely identifies output for this backup job from RC_RMAN_OUTPUT.
SESSION_STAMP	NUMBER	With SESSION_RECID, uniquely identifies output for this backup job from RC_RMAN_OUTPUT.
DB_KEY	NUMBER	The primary key for this database in the recovery catalog. Use this column to join with almost any other catalog view.
DB_NAME	VARCHAR2 (8)	The DB_NAME of the database incarnation to which this record belongs.
RSR_KEY	NUMBER	Unique key for the row in RC_RMAN_STATUS corresponding to the job that created this copy.

Column	Data Type	Description
COPY_KEY	NUMBER	Unique identifier for this data file or control file copy.
FILE#	NUMBER	The absolute file number for the data file, for data file copies.
NAME	VARCHAR2 (1024)	The file name of the data file or control file copy.
TAG	VARCHAR2 (32)	The tag, if any, for this data file or control file copy.
CREATION_CHANGE#	NUMBER	The creation SCN of the data file, for data files.
CREATION_TIME	DATE	The creation time of the file.
CHECKPOINT_CHANGE#	NUMBER	The SCN of the most recent data file checkpoint.
CHECKPOINT_TIME	DATE	The time of the most recent data file checkpoint.
MARKED_CORRUPT	NUMBER	Number of blocks in the data file that are marked corrupt, based on RC_DATABASE_BLOCK_CORRUPTION view.
OUTPUT_BYTES	NUMBER	Sum of sizes of all output pieces generated by this job.
COMPLETION_TIME	DATE	The completion time for this file copy.
CONTROLFILE_TYPE	VARCHAR2 (1)	The type of control file backed up, for control file copies: B (normal copy) or S (standby copy). Otherwise, NULL.
KEEP	VARCHAR2 (3)	YES, if this copy has a retention policy different from the value for CONFIGURE RETENTION POLICY. Otherwise, NO.
KEEP_UNTIL	DATE	If the KEEP UNTIL TIME clause of the BACKUP command was specified, then this column shows the data after which this file copy becomes obsolete. If the column is NULL and KEEP_OPTIONS is not null, then this copy never becomes obsolete.
KEEP_OPTIONS	VARCHAR2 (11)	The KEEP options specified for this data file copy. Possible values are NOLOGS, BACKUP_LOGS, LOGS, and NULL. NOLOGS indicates a consistent backup made when the database was mounted. BACKUP_LOGS indicates that the backup while the database was open, so archived log backups must be applied to make it consistent. LOGS indicates a long-term backup made with the LOGS keyword, which is now deprecated. NULL indicates that this backup has no KEEP options and becomes obsolete based on the backup retention policy.
IS_RECOVERY_DEST_FILE	VARCHAR2 (3)	YES if this copy is located in the fast recovery area. Otherwise, NO.
OUTPUT_BYTES_DISPLAY	VARCHAR2 (32K)	Same value as OUTPUT_BYTES, but converted to a user-displayable format, for example, 798.01M or 5.25G.

## 5.9 RC\_BACKUP\_COPY\_SUMMARY

RC\_BACKUP\_COPY\_SUMMARY contains summary information about all AVAILABLE control file and data file copies for each database.

This view is primarily intended to be used internally by Enterprise Manager.

Column	Data Type	Description
DB_NAME	VARCHAR2 (8)	The DB_NAME of the database incarnation to which this record belongs.
DB_KEY	NUMBER	The primary key for this database in the recovery catalog. Use this column to join with almost any other catalog view.
NUM_COPIES	NUMBER	Total number of image copy backups.
NUM_DISTINCT_COPIES	NUMBER	Number of distinct image copy backups.
MIN_CHECKPOINT_CHANGE#	NUMBER	Minimum checkpoint SCN among all image copy backups described in this view.
MAX_CHECKPOINT_CHANGE#	NUMBER	Maximum checkpoint SCN among all image copy backups described in this view.
MIN_CHECKPOINT_TIME	DATE	Earliest checkpoint time among all copies described in this view.
MAX_CHECKPOINT_TIME	DATE	Latest checkpoint time among all copies described in this view.
OUTPUT_BYTES	NUMBER	Sum of sizes of all data file and control file copies.
OUTPUT_BYTES_DISPLAY	VARCHAR2 (32K)	Same value as OUTPUT_BYTES, but converted to a user-displayable format, for example, 798.01M or 5.25G.

## 5.10 RC\_BACKUP\_CORRUPTION

This view lists corrupt block ranges in data file backups, which may be detected when BACKUP VALIDATE is used or the MAXCORRUPT parameter is greater than 0.

It corresponds to the V\$BACKUP\_CORRUPTION view in the control file. Corruptions are not tolerated in control file and archived redo log backups.

Column	Data Type	Description
DB_KEY	NUMBER	The primary key for this database in the recovery catalog. Use this column to join with almost any other catalog view.
DBINC_KEY	NUMBER	The primary key for the incarnation of the target database. Use this column to join with RC_DATABASE_INCARNATION.
DB_NAME	VARCHAR2 (8)	The DB_NAME of the database incarnation to which this record belongs.

Column	Data Type	Description
RECID	NUMBER	The record identifier from V\$BACKUP_CORRUPTION. RECID and STAMP form a concatenated primary key that uniquely identifies this record in the target database control file.
STAMP	NUMBER	The stamp propagated from V\$BACKUP_CORRUPTION. RECID and STAMP form a concatenated primary key that uniquely identifies this record in the target database control file.
BS_KEY	NUMBER	The primary key of the backup set to which this record belongs in the recovery catalog. Use this column to join with RC_BACKUP_SET or RC_BACKUP_PIECE.
SET_STAMP	NUMBER	The SET_STAMP value from V\$BACKUP_SET. SET_STAMP and SET_COUNT form a concatenated key that uniquely identifies the backup set to which this record belongs in the target database control file.
SET_COUNT	NUMBER	The SET_COUNT value from V\$BACKUP_SET. SET_STAMP and SET_COUNT form a concatenated key that uniquely identifies the backup set to which this record belongs in the target database control file.
PIECE#	NUMBER	The backup piece that contains this corrupt block.
BDF_KEY	NUMBER	The primary key for the data file backup or copy in the recovery catalog. Use this key to join with RC_BACKUP_DATAFILE. If you issue the LIST command while RMAN is connected to the recovery catalog, then this value appears in the KEY column of the output.
BDF_RECID	NUMBER	The RECID value from V\$BACKUP_DATAFILE.
BDF_STAMP	NUMBER	The STAMP value from V\$BACKUP_DATAFILE.
FILE#	NUMBER	The absolute file number for the data file that contains the corrupt blocks.
CREATION_CHANGE#	NUMBER	The creation SCN of the data file containing the corrupt blocks.
BLOCK#	NUMBER	The block number of the first corrupted block in this range of corrupted blocks.
BLOCKS	NUMBER	The number of corrupted blocks found beginning with BLOCK#.
CORRUPTION_CHANGE#	NUMBER	For media corrupt blocks, this value is zero. For logically corrupt blocks, this value is the lowest SCN in the blocks in this corrupt range.

Column	Data Type	Description
MARKED_CORRUPT	VARCHAR2 (3)	YES if this corruption was not previously detected by Oracle, or NO if Oracle Database has discovered this corrupt block and marked it in the database as corrupt. When a corrupt block is encountered in a backup, and is not marked corrupt by Oracle Database, then the backup process does not mark the block as corrupt in the production data file. Thus, this field may be YES for the same block in multiple backup sets.
CORRUPTION_TYPE	VARCHAR2 (9)	Same as RC_DATABASE_BLOCK_CORRUPTION.CORRUPTION_TYPE.

## 5.11 RC\_BACKUP\_DATAFILE

This view lists information about data files in backup sets. It corresponds to the V\$BACKUP\_DATAFILE view. A backup data file is uniquely identified by BDF\_KEY.

Column	Data Type	Description
DB_KEY	NUMBER	The primary key for this database in the recovery catalog. Use this column to join with almost any other catalog view.
DBINC_KEY	NUMBER	The primary key for the incarnation of the target database. Use this column to join with RC_DATABASE_INCARNATION.
DB_NAME	VARCHAR2 (8)	The DB_NAME of the database incarnation to which this record belongs.
PDB_KEY	NUMBER	The primary key of the PDB in the recovery catalog. Use this column to identify the PDB that owns the backups.
BDF_KEY	NUMBER	The primary key of the data file backup in the recovery catalog. If you issue the LIST command while RMAN is connected to the recovery catalog, then this value appears in the KEY column of the output.
RECID	NUMBER	The backup data file RECID from V\$BACKUP_DATAFILE. RECID and STAMP form a concatenated primary key that uniquely identifies this record in the target database control file.
STAMP	NUMBER	The backup data file stamp from V\$BACKUP_DATAFILE. RECID and STAMP form a concatenated primary key that uniquely identifies this record in the target database control file.
BS_KEY	NUMBER	The primary key of the backup set to which this record belongs in the recovery catalog. Use this column to join with RC_BACKUP_SET or RC_BACKUP_PIECE.

Column	Data Type	Description
SET_STAMP	NUMBER	The SET_STAMP value from V\$BACKUP_SET. SET_STAMP and SET_COUNT form a concatenated key that uniquely identifies the backup set to which this record belongs in the target database control file.
SET_COUNT	NUMBER	The SET_COUNT value from V\$BACKUP_SET. SET_STAMP and SET_COUNT form a concatenated key that uniquely identifies the backup set to which this record belongs in the target database control file.
BS_RECID	NUMBER	The RECID from V\$BACKUP_SET.
BS_STAMP	NUMBER	The STAMP from V\$BACKUP_SET.
BACKUP_TYPE	VARCHAR2 (1)	The type of the backup: D (full or level 0 incremental) or I (incremental level 1).
INCREMENTAL_LEVEL	NUMBER	The level of the incremental backup: NULL, 0, or 1.
COMPLETION_TIME	DATE	The completion time of the backup.
FILE#	NUMBER	The absolute file number of the data file. When FILE#=0, the record refers to the control file. See the note following this table for special semantics of other columns when FILE#=0.
CREATION_CHANGE#	NUMBER	The creation SCN of the data file.
RESETLOGS_CHANGE#	NUMBER	The SCN of the most recent RESETLOGS in the data file header.
RESETLOGS_TIME	DATE	The time stamp of the most recent RESETLOGS in the data file header.
INCREMENTAL_CHANGE#	NUMBER	The SCN that determines whether a block is included in the incremental backup. A block is only included if the SCN in the block header is greater than or equal to INCREMENTAL_CHANGE#. The range of redo covered by the incremental backup begins with INCREMENTAL_CHANGE# and ends with CHECKPOINT_CHANGE#.
CHECKPOINT_CHANGE#	NUMBER	The checkpoint SCN of this data file in this backup set.
CHECKPOINT_TIME	DATE	The time associated with CHECKPOINT_CHANGE#.
ABSOLUTE_FUZZY_CHANGE#	NUMBER	The absolute fuzzy SCN. See the note following this table for special semantics when FILE#=0.
DATAFILE_BLOCKS	NUMBER	The number of data blocks in the data file.
BLOCKS	NUMBER	The number of data blocks written to the backup. This value is often less than DATAFILE_BLOCKS because for full backups, blocks that have never been used are not included in the backup, and for incremental backups, blocks that have not changed are not included in the backup. This value is never greater than DATAFILE_BLOCKS.
BLOCK_SIZE	NUMBER	The size of the data blocks in bytes.

Column	Data Type	Description
STATUS	VARCHAR2 (1)	The status of the backup set: A (all pieces available), D (all pieces deleted), O (some pieces are available but others are not, so the backup set is unusable).
BS_LEVEL	NUMBER	The incremental level (NULL, 0, or 1) specified when this backup was created. This value can be different from the INCREMENTAL_LEVEL column because if you run, for example, a level 1 incremental backup, but no previous level 0 backup exists for some files, a level 0 backup is automatically taken for these files. In this case, BS_LEVEL is 0 and INCREMENTAL_LEVEL is 0.
PIECES	NUMBER	The number of backup pieces in the backup set that contains this backup data file.
BLOCKS_READ	NUMBER	Number of blocks that were scanned while taking this backup. If this was an incremental backup, and change tracking was used to optimize the backup, then the value of this column is smaller than DATAFILE_BLOCKS. Otherwise, the value of this column equals DATAFILE_BLOCKS. Even when change tracking data is used, the value of this column may be larger than BLOCKS, because the data read by change tracking is further refined during the process of creating an incremental backup.
CREATION_TIME	DATE	Creation timestamp of the data file.
MARKED_CORRUPT	NUMBER	Number of blocks marked corrupt.
USED_CHANGE_TRACKING	VARCHAR2 (3)	Whether change tracking data was used to accelerate this incremental backup (YES) or was not used (NO).
USED_OPTIMIZATION	VARCHAR2 (3)	Whether backup optimization was applied (YES) or not (NO).
PCT_NOTREAD	NUMBER	The percentage of the file that was skipped during this backup. For incremental backups, this value indicates the efficiency of the block change tracking file.
FOREIGN_DBID	NUMBER	Foreign DBID of the database from which this data file was transported. The value is 0 if the file backed up is not a foreign database file.
PLUGGED_READONLY	VARCHAR2 (3)	YES if this is a backup of a transported read-only foreign file; otherwise NO.
PLUGIN_CHANGE#	NUMBER	SCN at which the foreign data file was transported into the database. The value is 0 if this file is not a foreign database file.
PLUGIN_RESETLOGS_CHANGE#	NUMBER	The SCN of the RESETLOGS operation for the incarnation into which this foreign file was transported. The value is 0 if this file is not a foreign database file.

Column	Data Type	Description
PLUGIN_RESETLOGS_TIME	DATE	The time of the RESETLOGS operation for the incarnation into which this foreign file was transported. The value is 0 if this file is not a foreign database file.
SECTION_SIZE	NUMBER	Specifies the number of blocks in each section of a multisection backup. Value is 0 for whole file backups.
SPARSE_BACKUP	VARCHAR2 (3)	Indicates if the backup is a sparse backup

## 5.12 RC\_BACKUP\_DATAFILE\_DETAILS

RC\_BACKUP\_DATAFILE\_DETAILS provides detailed information about available data file backups for databases registered in the recovery catalog.

This view is primarily intended to be used internally by Enterprise Manager.

Column	Data Type	Description
BTYPE	CHAR (9)	The backup type container, which can be BACKUPSET, IMAGECOPY, or PROXYCOPY.
BTYPE_KEY	NUMBER	Unique identifier for the backup type. If BTYPE is BACKUPSET, then this value is the BS_KEY value for the backup set. If BTYPE is IMAGECOPY, then this value is the value of COPY_KEY for the copy.
SESSION_KEY	NUMBER	Session identifier. Use in joins with RC_RMAN_OUTPUT and RC_RMAN_BACKUP_JOB_DETAILS.
SESSION_RECID	NUMBER	With SESSION_STAMP, uniquely identifies output for this backup job from RC_RMAN_OUTPUT.
SESSION_STAMP	NUMBER	With SESSION_RECID, uniquely identifies output for this backup job from RC_RMAN_OUTPUT.
DB_KEY	NUMBER	The primary key for this database in the recovery catalog. Use this column to join with almost any other catalog view.
DB_NAME	VARCHAR2 (8)	The DB_NAME of the database incarnation to which this record belongs.
ID1	NUMBER	For backups taken as backup sets, this column contains SET_STAMP. For proxy copy or image copy backups, this column contains the RECID from the control file.
ID2	NUMBER	For backups taken as backup sets, this column contains SET_COUNT. For proxy copy or image copy backups, this column contains STAMP.
FILE#	NUMBER	The number of this data file.
CREATION_CHANGE#	NUMBER	The checkpoint SCN when this data file was created.
CREATION_TIME	DATE	The time at which this data file was created.



Column	Data Type	Description
RESETLOGS_CHANGE#	NUMBER	The checkpoint SCN of the most recent RESETLOGS operation affecting this data file.
RESETLOGS_TIME	DATE	The time of the most recent RESETLOGS operation affecting this data file
INCREMENTAL_LEVEL	NUMBER	For incremental backups, the level of the incremental backup (0 or 1). Otherwise, NULL.
INCREMENTAL_CHANGE#	NUMBER	For incremental backups, the incremental backup SCN. Otherwise, NULL.
CHECKPOINT_CHANGE#	NUMBER	The current checkpoint SCN for the data file at the time it was backed up.
CHECKPOINT_TIME	DATE	The time corresponding to the current checkpoint SCN for the data file at the time it was backed up.
MARKED_CORRUPT	NUMBER	Number of data file blocks marked corrupt.
FILESIZE	NUMBER	The size of the data file at the time it was backed up.
COMPRESSION_RATIO	NUMBER	Compression ratio for this backup.
CON_ID	NUMBER	The ID of the container to which the data pertains. Possible values include: <ul style="list-style-type: none"> <li>• 0: Rows containing data that pertain to the whole multitenant container database (CDB)</li> <li>• 1: Rows containing data that pertains only to the root</li> <li>• <i>n</i>: Where <i>n</i> is the applicable container ID for the rows containing data</li> </ul>
PDB_NAME	VARCHAR2 (31)	Name of the pluggable database (PDB).
PDB_KEY	NUMBER	The primary key for this PDB in the recovery catalog.
TS#	NUMBER	Tablespace number.
TSNAME	VARCHAR2 (30)	The name of the tablespace containing this data file.
FILESIZE_DISPLAY	VARCHAR2 (32K)	Same value as FILESIZE, but converted to a user-displayable format, for example, 798.01M or 5.25G.

## 5.13 RC\_BACKUP\_DATAFILE\_SUMMARY

RC\_BACKUP\_DATAFILE\_SUMMARY provides summary information about available backups of data files.

This view is primarily intended to be used internally by Enterprise Manager.

Column	Data Type	Description
DB_KEY	NUMBER	The primary key for this database in the recovery catalog. Use this column to join with almost any other catalog view.

Column	Data Type	Description
DB_NAME	VARCHAR2 (8)	The DB_NAME of the database incarnation to which this record belongs.
NUM_FILES_BACKED	NUMBER	Number of data files backed up for this value of DB_KEY and DB_NAME.
NUM_DISTINCT_FILES_BACKED	NUMBER	Number of distinct files backed up for this value of DB_KEY and DB_NAME.
NUM_DISTINCT_TS_BACKED	NUMBER	Number of distinct tablespaces backed up for this value of DB_KEY and DB_NAME.
MIN_CHECKPOINT_CHANGE#	NUMBER	Minimum checkpoint of any data file backed up for this value of DB_KEY and DB_NAME.
MAX_CHECKPOINT_CHANGE#	NUMBER	Maximum checkpoint change number of any data file backed up for this value of DB_KEY and DB_NAME.
MIN_CHECKPOINT_TIME	DATE	Minimum checkpoint time for any data file backed up for this value of DB_KEY and DB_NAME.
MAX_CHECKPOINT_TIME	DATE	Maximum checkpoint time for any data file backed up for this value of DB_KEY and DB_NAME.
INPUT_BYTES	NUMBER	Total input bytes read for all files backed up for this value of DB_KEY and DB_NAME.
OUTPUT_BYTES	NUMBER	Sum of sizes of all output pieces generated by backups for this value of DB_KEY and DB_NAME.
COMPRESSION_RATIO	NUMBER	Compression ratio across all backups.
INPUT_BYTES_DISPLAY	VARCHAR2 (32K)	Same value as INPUT_BYTES, but converted to a user-displayable format, for example, 798.01M or 5.25G.
OUTPUT_BYTES_DISPLAY	VARCHAR2 (32K)	Same value as OUTPUT_BYTES, but converted to a user-displayable format, for example, 798.01M or 5.25G.

## 5.14 RC\_BACKUP\_FILES

This view lists backups known to the RMAN repository as reflected in the recovery catalog.

This view corresponds to the V\$BACKUP\_FILES control file view.

### Note:

- It is usually more convenient to access this information using the LIST BACKUP and LIST COPY commands from within RMAN.
- You must use DBMS\_RCVMAN.SetDatabase to select a database from the recovery catalog schema before you can use this view, even if only one database is registered in the recovery catalog. *Oracle Database Backup and Recovery User's Guide* explains how to perform this task.

Column	Data Type	Description
PKEY	NUMBER	The primary key for the backup.
BACKUP_TYPE	VARCHAR2 (32)	The type of the backup: BACKUP SET, COPY, or PROXY COPY.
FILE_TYPE	VARCHAR2 (32)	Type of the file backed up: DATAFILE, CONTROLFILE, SPFILE, REDO LOG, ARCHIVED LOG, COPY (for an image copy backup) or PIECE (for a backup piece).
KEEP	VARCHAR2 (3)	Whether this backup has KEEP attributes set that override the backup retention policy. Values are YES or NO.
KEEP_UNTIL	DATE	Date after which this backup is considered obsolete.
KEEP_OPTIONS	VARCHAR2 (13)	Attributes affecting retention for this backup. Possible values are NOLOGS, BACKUP_LOGS, LOGS, and NULL. NOLOGS indicates a consistent backup made when the database was mounted. BACKUP_LOGS indicates that the backup was made in open mode, so archived log backups must be applied to make it consistent. LOGS indicates a long-term backup made with the LOGS keyword, which is now deprecated. NULL indicates that this backup has no KEEP options and becomes obsolete based on the retention policy.
STATUS	VARCHAR2 (16)	Status of the backup. Possible values are: AVAILABLE, UNAVAILABLE, EXPIRED.
FNAME	VARCHAR2 (1024)	File name of this piece, copy, or file name of the file included in this backup set. For example, for a row whose BACKUP_TYPE is BACKUP SET and FILE_TYPE is DATAFILE, FNAME is the name of the data file in the backup. On the other hand, if BACKUP_TYPE is BACKUP SET and FILE_TYPE is PIECE, then FNAME shows the name of backup piece.
TAG	VARCHAR2 (32)	The tag for this backup piece or image copy. This column can only have a value if FILE_TYPE is PIECE or COPY.
MEDIA	VARCHAR2 (80)	Media ID for the media on which the backup is stored. This column can only have a value if BACKUP_TYPE is BACKUP SET and FILE_TYPE is PIECE.
RECID	NUMBER	ID of the control file record corresponding to this row.
STAMP	NUMBER	Timestamp of the control file record corresponding to this row.
DEVICE_TYPE	VARCHAR2 (255)	Device type on which this backup is stored. This column populated only if FILE_TYPE is PIECE or COPY.
BLOCK_SIZE	NUMBER	Block size for the backup or copy (in bytes).

Column	Data Type	Description
COMPLETION_TIME	NUMBER	Time when this backup was completed. This column populated only if FILE_TYPE is PIECE or COPY.
COMPRESSED	VARCHAR2 (3)	Whether the backup piece represented by this row is compressed. This column populated only if file-type is PIECE (since image copies cannot be compressed, by definition).
OBSOLETE	VARCHAR2 (3)	Whether this backup piece or copy is obsolete. Possible value: YES, NO. This column populated only if FILE_TYPE is PIECE or COPY.
BYTES	NUMBER	Size of file described by this row. If BACKUP_TYPE is BACKUP SET, this represents the total size of the backup set. If FILE_TYPE is PIECE or COPY, then this represents the size of the individual file. If FILE_TYPE is DATAFILE, ARCHIVED LOG, SPFILE or CONTROL FILE, the value represents how much data was incorporated into the backup set (but the corresponding backup set may be smaller, if compression was used in creating the backup set).
BS_KEY	NUMBER	Backup set key. This column populated only if BACKUP_TYPE is BACKUP SET. Use this column to join with RC_BACKUP_SET or RC_BACKUP_PIECE.
BS_COUNT	NUMBER	Backup set count. This column populated only if BACKUP_TYPE is BACKUP SET.
BS_STAMP	NUMBER	Backup set timestamp. This column populated only if BACKUP_TYPE is BACKUP SET.
BS_TYPE	VARCHAR2 (32)	Type of backup set contents (data files or archived redo log files). This column populated only if BACKUP_TYPE is BACKUP SET.
BS_INCR_TYPE	VARCHAR (32)	Backup set incremental type (full or not). This column populated only if BACKUP_TYPE is BACKUP SET.
BS_PIECES	NUMBER	Number of pieces in backup set. This column populated only if BACKUP_TYPE is BACKUP SET.
BS_COPIES	NUMBER	Number of copies of this backup set. This column populated only if BACKUP_TYPE is BACKUP SET.
BS_COMPLETION_TIME	DATE	Completion time of the backup set. This column populated only if BACKUP_TYPE is BACKUP SET.
BS_STATUS	VARCHAR2 (16)	Status of the backup set. Possible values are AVAILABLE, UNAVAILABLE, EXPIRED, or OTHER. (OTHER means that not all pieces of the backup set have the same status, which can happen if some are AVAILABLE and others UNAVAILABLE.) This column populated only if BACKUP_TYPE is BACKUP SET.
BS_BYTES	NUMBER	Sum of the sizes of all backup pieces in the backup set. This column populated only if BACKUP_TYPE is BACKUP SET.

Column	Data Type	Description
BS_COMPRESSED	VARCHAR2 (3)	Whether the backup pieces of this backup set are compressed. This column populated only if BACKUP_TYPE is BACKUP SET.
BS_TAG	VARCHAR2 (1024)	Tag or tags of the backup pieces of this backup set. If pieces have different tags, then BS_TAGS contains a comma-delimited list of all tags for pieces in the backup set. This column populated only if BACKUP_TYPE is BACKUP SET.
BS_DEVICE_TYPE	VARCHAR2 (255)	Type of device on which this backup set is stored. If multiple copies of this backup set exist and are stored on different devices, then this field contains a comma-delimited list of all device types. For example, for a backup set that is on disk and also backed up on tape, BS_DEVICE_TYPE might contain DISK, SBT_TAPE. This column populated only if BACKUP_TYPE is BACKUP SET.
BP_PIECE#	NUMBER	Number of backup pieces that compose this backup set. This column populated only if BACKUP_TYPE is BACKUP SET.
BP_COPY#	NUMBER	Number of copies of this backup set. This column populated only if BACKUP_TYPE is BACKUP SET.
DF_FILE#	NUMBER	File number of the data file described by this row. This column populated only if FILE_TYPE is DATAFILE.
DF_TABLESPACE	VARCHAR2 (30)	Tablespace name for the data file described by this row. This column populated only if FILE_TYPE is DATAFILE.
DF_RESETLOGS_CHANGE#	NUMBER	RESETLOGS change of the data file described by this row. This column populated only if FILE_TYPE is DATAFILE.
DF_CREATION_CHANGE#	NUMBER	Creation change number of the data file described by this row. This column populated only if FILE_TYPE is CONTROLFILE, DATAFILE or SPFILE.
DF_CHECKPOINT_CHANGE#	NUMBER	Checkpoint change number of the data file described by this row. This column populated only if FILE_TYPE is CONTROLFILE, DATAFILE or SPFILE.
DF_CKP_MOD_TIME	DATE	Checkpoint time of the data file described by this row. Valid only if FILE_TYPE is CONTROLFILE, DATAFILE or SPFILE.
RL_THREAD#	NUMBER	Redo log thread number of the archived redo log described by this row. Valid only if FILE_TYPE is ARCHIVED LOG.
RL_SEQUENCE#	NUMBER	Redo log sequence number of the archived redo log described by this row. Valid only if FILE_TYPE is ARCHIVED LOG.

Column	Data Type	Description
RL_RESETLOGS_CHANGE#	NUMBER	RESETLOGS change number of the archived redo log described by this row. Valid only if FILE_TYPE is ARCHIVED LOG.
RL_FIRST_CHANGE#	NUMBER	First change number in the archived redo log described by this row. Valid only if FILE_TYPE is ARCHIVED LOG.
RL_FIRST_TIME	DATE	Time of the first change in the archived redo log described by this row. Valid only if FILE_TYPE is ARCHIVED LOG.
RL_NEXT_CHANGE#	NUMBER	Change number after the archived log described by this row. Valid only if FILE_TYPE is ARCHIVED LOG.
RL_NEXT_TIME	DATE	Time of the first change after the archived log described by this row. Valid only if FILE_TYPE is ARCHIVED LOG.

## 5.15 RC\_BACKUP\_PIECE

This view lists information about backup pieces. This view corresponds to the V\$BACKUP\_PIECE view.

Each backup set contains one or more backup pieces. Multiple copies of the same backup piece can exist, but each copy has its own record in the control file and its own row in the view.

Column	Data Type	Description
DB_KEY	NUMBER	The primary key for this database in the recovery catalog. Use this column to join with almost any other catalog view.
DB_ID	NUMBER	The database identifier.
PDB_KEY	NUMBER	The primary key of the PDB in the recovery catalog. Use this column to identify the PDB that owns the backup piece.
BP_KEY	NUMBER	The primary key for the backup piece in the recovery catalog. If you issue the LIST command while RMAN is connected to the recovery catalog, then this value appears in the KEY column of the output.
RECID	NUMBER	The backup piece RECID from V\$BACKUP_PIECE. RECID and STAMP form a concatenated primary key that uniquely identifies this record in the target database control file.
STAMP	NUMBER	The backup piece stamp propagated from V\$BACKUP_PIECE. RECID and STAMP form a concatenated primary key that uniquely identifies this record in the target database control file.

Column	Data Type	Description
BS_KEY	NUMBER	The primary key of the backup set to which this record belongs in the recovery catalog. Use this column to join with RC_BACKUP_SET, RC_BACKUP_CONTROLFILE, RC_BACKUP_DATAFILE, and so on.
SET_STAMP	NUMBER	The SET_STAMP value from V\$BACKUP_SET. SET_STAMP and SET_COUNT form a concatenated key that uniquely identifies the backup set to which this record belongs in the target database control file.
SET_COUNT	NUMBER	The SET_COUNT value from V\$BACKUP_SET. SET_STAMP and SET_COUNT form a concatenated key that uniquely identifies the backup set to which this record belongs in the target database control file.
BACKUP_TYPE	VARCHAR2 (1)	The type of the backup: D (full or level 0 incremental), I (incremental level 1), L (archived redo log).
INCREMENTAL_LEVEL	NUMBER	The level of the incremental backup: NULL, 0, or 1.
PIECE#	NUMBER	The number of the backup piece. The first piece has the value of 1.
COPY#	NUMBER	The copy number of the backup piece.
DEVICE_TYPE	VARCHAR2 (255)	The type of backup device, for example, DISK.
HANDLE	VARCHAR2 (1024)	The file name of the backup piece.
COMMENTS	VARCHAR2 (255)	Comments about the backup piece.
MEDIA	VARCHAR2 (80)	A comment that contains further information about the media manager that created this backup.
MEDIA_POOL	NUMBER	The number of the media pool in which the backup is stored.
CONCUR	VARCHAR2 (3)	Specifies whether backup media supports concurrent access: YES or NO.
TAG	VARCHAR2 (32)	The tag for the backup piece. Refer to description in <a href="#">BACKUP</a> for default format for tag names.
START_TIME	DATE	The time when RMAN started to write the backup piece.
COMPLETION_TIME	DATE	The time when the backup piece was completed.
ELAPSED_SECONDS	NUMBER	The duration of the creation of the backup piece.
STATUS	VARCHAR2 (1)	The status of the backup piece: A (available), U (unavailable), D (deleted), or X (expired). Status D does not appear unless an older recovery catalog is upgraded.
BYTES	NUMBER	The size of the backup piece in bytes.
IS_RECOVERY_DEST_FILE	VARCHAR2 (3)	This backup piece is located in the fast recovery area: YES or NO.

Column	Data Type	Description
RSR_KEY	NUMBER	Unique key for the row in RC_RMAN_STATUS that created this backup piece.
COMPRESSED	VARCHAR2 (3)	Indicates whether the backup piece is compressed (YES) or not (NO).
SITE_KEY	NUMBER	Primary key of the Data Guard database associated with this file. Each database in a Data Guard environment has a unique SITE_KEY value. You can use SITE_KEY in a join with the RC_SITE view to obtain the DB_UNIQUE_NAME of the database.
ENCRYPTED	VARCHAR2 (3)	Indicates whether the backup piece is encrypted (YES) or not (NO).
BACKED_BY_OSB	VARCHAR2 (3)	Indicates whether the backup piece is backed up to Oracle Secure Backup (YES) or not (NO).
BA_ACCESS	VARCHAR2 (11)	Indicates how Zero Data Loss Recovery Appliance, commonly known as Recovery Appliance, will access the backup piece. This column is applicable only when RMAN is used with Recovery Appliance. The possible values are: <ul style="list-style-type: none"> <li>• <b>Unknown:</b> Recovery Appliance has no access to this backup piece</li> <li>• <b>Local:</b> The backup piece is stored in an Recovery Appliance storage location</li> <li>• <b>Tape:</b> The backup piece is accessible through an SBT interface installed on Recovery Appliance</li> <li>• <b>Disk:</b> The backup piece is available on a disk that is accessible to Recovery Appliance</li> </ul>
VB_KEY	NUMBER	The virtual backup ID. This value is NOT NULL if the backup piece is being dynamically built from the store location. Backup pieces with the same value for VB_KEY share a common source backup piece.
VIRTUAL	VARCHAR2 (3)	Indicates if the backup piece can be dynamically built. Possible values are: <ul style="list-style-type: none"> <li>• <b>Yes:</b> The backup piece can be dynamically built from the backup storage location.</li> <li>• <b>No:</b> The backup piece cannot be built from the backup storage location.</li> </ul>
LIB_KEY	NUMBER	The library key of the SBT library defined on Recovery Appliance to which the backup piece is written.

## 5.16 RC\_BACKUP\_PIECE\_DETAILS

RC\_BACKUP\_PIECE\_DETAILS contains detailed information about all available backup pieces recorded in the recovery catalog.



The semantics of most columns duplicate the RC\_BACKUP\_PIECE recovery catalog view. This view is primarily intended to be used internally by Enterprise Manager.

Column	Data Type	Description
SESSION_KEY	NUMBER	Session identifier. Use in joins with RC_RMAN_OUTPUT and RC_RMAN_BACKUP_JOB_DETAILS.
SESSION_RECID	NUMBER	With SESSION_STAMP, uniquely identifies output for this backup job from RC_RMAN_OUTPUT.
SESSION_STAMP	NUMBER	With SESSION_RECID, uniquely identifies output for this backup job from RC_RMAN_OUTPUT.
DB_NAME	VARCHAR2 (8)	The DB_NAME of the database incarnation to which this record belongs.
DB_KEY	NUMBER	The primary key for this database in the recovery catalog. Use this column to join with almost any other catalog view.
DB_ID	NUMBER	The DBID of the database incarnation to which this record belongs.
BP_KEY	NUMBER	The primary key for the backup piece in the recovery catalog. If you issue the LIST command while RMAN is connected to the recovery catalog, then this value appears in the KEY column of the output.
RECID	NUMBER	The backup piece RECID from RC_BACKUP_PIECE. RECID and STAMP form a concatenated primary key that uniquely identifies this record in the target database control file.
STAMP	NUMBER	The backup piece stamp propagated from V\$BACKUP_PIECE. RECID and STAMP form a concatenated primary key that uniquely identifies this record in the target database control file.
BS_KEY	NUMBER	The primary key of the backup set to which this record belongs in the recovery catalog. Use this column to join with RC_BACKUP_SET or RC_BACKUP_PIECE.
SET_STAMP	NUMBER	The SET_STAMP value from V\$BACKUP_SET. SET_STAMP and SET_COUNT form a concatenated key that uniquely identifies the backup set to which this record belongs in the target database control file.
SET_COUNT	NUMBER	The SET_COUNT value from V\$BACKUP_SET. SET_STAMP and SET_COUNT form a concatenated key that uniquely identifies the backup set to which this record belongs in the target database control file.
BACKUP_TYPE	VARCHAR2 (1)	The type of backup. Possible values are D for data file or control file backups, I for incremental backups, and L for archived log file backups.
INCREMENTAL_LEVEL	NUMBER	For incremental backups, indicates the level of incremental backup. Possible values are NULL (for full backups), 0 or 1.

Column	Data Type	Description
PIECE#	NUMBER	The number of the backup piece. The first piece has the value of 1.
COPY#	NUMBER	Indicates the copy number for backup pieces created with duplex enabled. 1 if the backup piece is not duplexed.
DEVICE_TYPE	VARCHAR2 (255)	Type of the device on which the backup piece resides. Set to <code>DISK</code> for backup sets on disk.
HANDLE	VARCHAR2 (1024)	The file name of the backup piece.
COMMENTS	VARCHAR2 (255)	Comments about the backup piece.
MEDIA	VARCHAR2 (80)	A comment that contains further information about the media manager that created this backup.
MEDIA_POOL	NUMBER	The number of the media pool in which the backup is stored. 0 indicates no media pool.
CONCUR	VARCHAR2 (3)	Specifies whether backup media supports concurrent access: <code>YES</code> or <code>NO</code> .
TAG	VARCHAR2 (32)	The tag associated with this backup piece.
START_TIME	DATE	The time when RMAN started to write the backup piece.
COMPLETION_TIME	DATE	The time when the backup piece was completed.
ELAPSED_SECONDS	NUMBER	The duration of the creation of the backup piece.
STATUS	VARCHAR2 (1)	The status of the backup piece: <code>A</code> for backup pieces that are <code>AVAILABLE</code> . (The value is always <code>A</code> , because this view shows only available backup pieces.)
BYTES	NUMBER	The size of the backup piece in bytes.
IS_RECOVERY_DEST_FILE	VARCHAR2 (3)	<code>YES</code> if this backup piece is located in the fast recovery area. <code>NO</code> otherwise.
RSR_KEY	NUMBER	Unique key for the row in <code>RC_RMAN_STATUS</code> corresponding to the job that created this backup piece.
COMPRESSED	VARCHAR2 (3)	<code>YES</code> if this backup piece is compressed. <code>NO</code> otherwise.
SITE_KEY	NUMBER	Primary key of the Data Guard database associated with this file. Each database in a Data Guard environment has a unique <code>SITE_KEY</code> value. You can use <code>SITE_KEY</code> in a join with the <code>RC_SITE</code> view to obtain the <code>DB_UNIQUE_NAME</code> of the database.
ENCRYPTED	VARCHAR2 (3)	Indicates whether the backup piece is encrypted ( <code>YES</code> ) or not ( <code>NO</code> ).
BACKED_BY_OSB	VARCHAR2 (3)	Indicates whether the backup piece is backed up to Oracle Secure Backup ( <code>YES</code> ) or not ( <code>NO</code> ).
PIECES_PER_SET	NUMBER	Number of backup pieces in the backup set containing this backup piece.

Column	Data Type	Description
SIZE_BYTES_DISPLAY	VARCHAR2 (32K)	Same value as BYTES, but converted to a user-displayable format, for example, 798.01M or 5.25G.

## 5.17 RC\_BACKUP\_REDOLOG

This view lists information about archived redo log files in backup sets. It corresponds to the `V$BACKUP_REDOLOG` view.

You cannot back up online logs directly: you must first archive them to disk and then back them up. An archived log backup set contains one or more archived logs.

Column	Data Type	Description
DB_KEY	NUMBER	The primary key for this database in the recovery catalog. Use this column to join with almost any other catalog view.
DBINC_KEY	NUMBER	The primary key for the incarnation of the target database. Use this column to join with <code>RC_DATABASE_INCARNATION</code> .
DB_NAME	VARCHAR2 (8)	The <code>DB_NAME</code> of the database incarnation to which this record belongs.
BRL_KEY	NUMBER	The primary key of the archived redo log in the recovery catalog. If you issue the <code>LIST</code> command while <code>RMAN</code> is connected to the recovery catalog, then this value appears in the <code>KEY</code> column of the output.
RECID	NUMBER	The record identifier propagated from <code>V\$BACKUP_REDOLOG</code> . <code>RECID</code> and <code>STAMP</code> form a concatenated primary key that uniquely identifies this record in the target database control file.
STAMP	NUMBER	The stamp from <code>V\$BACKUP_REDOLOG</code> . <code>RECID</code> and <code>STAMP</code> form a concatenated primary key that uniquely identifies this record in the target database control file.
BS_KEY	NUMBER	The primary key of the backup set to which this record belongs in the recovery catalog. Use this column to join with <code>RC_BACKUP_SET</code> or <code>RC_BACKUP_PIECE</code> .
SET_STAMP	NUMBER	The <code>SET_STAMP</code> value from <code>V\$BACKUP_SET</code> . <code>SET_STAMP</code> and <code>SET_COUNT</code> form a concatenated key that uniquely identifies the backup set to which this record belongs in the target database control file.
SET_COUNT	NUMBER	The <code>SET_COUNT</code> value from <code>V\$BACKUP_SET</code> . <code>SET_STAMP</code> and <code>SET_COUNT</code> form a concatenated key that uniquely identifies the backup set to which this record belongs in the target database control file.

Column	Data Type	Description
BACKUP_TYPE	VARCHAR2 (1)	The type of the backup: L (archived redo log).
COMPLETION_TIME	DATE	The time when the backup completed.
THREAD#	NUMBER	The thread number of the redo log.
SEQUENCE#	NUMBER	The log sequence number.
RESETLOGS_CHANGE#	NUMBER	The SCN of the most recent RESETLOGS when the record was created.
RESETLOGS_TIME	DATE	The time stamp of the most recent RESETLOGS when the record was created.
FIRST_CHANGE#	NUMBER	The SCN generated when Oracle switched into the redo log.
FIRST_TIME	DATE	The time when Oracle switched into the redo log.
NEXT_CHANGE#	NUMBER	The first SCN of the next redo log in the thread.
NEXT_TIME	DATE	The first time stamp of the next redo log in the thread.
BLOCKS	NUMBER	The number of operating system blocks written to the backup.
BLOCK_SIZE	NUMBER	The number of bytes in each block of this redo log.
STATUS	VARCHAR2 (1)	The status of the backup set: A (all pieces available), D (all pieces deleted), O (some pieces are available but others are not, so the backup set is unusable).
BS_RECID	NUMBER	The RECID value from V\$BACKUP_SET.
BS_STAMP	NUMBER	The STAMP value from V\$BACKUP_SET. BS_STAMP is different from SET_STAMP. BS_STAMP is the stamp of the backup set record when created in the control file, whereas SET_STAMP joins with SET_COUNT to make a unique identifier.
PIECES	NUMBER	The number of pieces in the backup set.
TERMINAL	VARCHAR2 (3)	Indicates whether this log was created during terminal recovery of a standby database. Values are YES or NO.
PARTIAL	VARCHAR2 (3)	Indicates that this archivelog is created during the activation of failover of a standby database and it contains partial archivelog contents. It is created by Zero Data Loss Recovery Appliance (ZDLRA) when the connection with the primary database is lost. A value of YES indicates that the log is partial.

## 5.18 RC\_BACKUP\_SET

This view lists information about backup sets for all incarnations of the database.

It corresponds to the V\$BACKUP\_SET view. A backup set record is inserted after the backup has successfully completed.

Column	Data Type	Description
DB_KEY	NUMBER	The primary key for this database in the recovery catalog. Use this column to join with almost any other catalog view.
DB_ID	NUMBER	The unique database identifier.
PDB_KEY	NUMBER	The primary key of the PDB in the recovery catalog. Use this column to identify the PDB that owns the backup set.
BS_KEY	NUMBER	The primary key of the backup set in the recovery catalog. If you issue the <code>LIST</code> command while RMAN is connected to the recovery catalog, then this value appears in the <code>KEY</code> column of the output. Use this column to join with <code>RC_BACKUP_PIECE</code> .
RECID	NUMBER	The backup set <code>RECID</code> from <code>V\$BACKUP_SET</code> . <code>RECID</code> and <code>STAMP</code> form a concatenated primary key that uniquely identifies this record in the target database control file. Use either <code>RECID</code> and <code>STAMP</code> or <code>SET_STAMP</code> and <code>SET_COUNT</code> to access <code>V\$BACKUP_SET</code> .
STAMP	NUMBER	The backup set <code>STAMP</code> from <code>V\$BACKUP_SET</code> . <code>RECID</code> and <code>STAMP</code> form a concatenated primary key that uniquely identifies this record in the target database control file. Use either <code>RECID</code> and <code>STAMP</code> or <code>SET_STAMP</code> and <code>SET_COUNT</code> to access <code>V\$BACKUP_SET</code> .
SET_STAMP	NUMBER	The <code>SET_STAMP</code> value from <code>V\$BACKUP_SET</code> . <code>SET_STAMP</code> and <code>SET_COUNT</code> form a concatenated key that uniquely identifies this record in the target database control file. Use either <code>RECID</code> and <code>STAMP</code> or <code>SET_STAMP</code> and <code>SET_COUNT</code> to access <code>V\$BACKUP_SET</code> .
SET_COUNT	NUMBER	The <code>SET_COUNT</code> value from <code>V\$BACKUP_SET</code> . <code>SET_STAMP</code> and <code>SET_COUNT</code> form a concatenated key that uniquely identifies this record in the target database control file. Use either <code>RECID</code> and <code>STAMP</code> or <code>SET_STAMP</code> and <code>SET_COUNT</code> to access <code>V\$BACKUP_SET</code> .
BACKUP_TYPE	VARCHAR2 (1)	The type of the backup: <code>D</code> (full backup or level 0 incremental), <code>I</code> (incremental level 1), <code>L</code> (archived redo log).
INCREMENTAL_LEVEL	NUMBER	The level of the incremental backup: <code>NULL</code> , <code>0</code> , or <code>1</code> .
PIECES	NUMBER	The number of backup pieces in the backup set.
START_TIME	DATE	The time when the backup began.
COMPLETION_TIME	DATE	The time when the backup completed.
ELAPSED_SECONDS	NUMBER	The duration of the backup in seconds.

Column	Data Type	Description
STATUS	VARCHAR2 (1)	The status of the backup set: A (all backup pieces available), D (all backup pieces deleted), O (some backup pieces are available but others are not, so the backup set is unusable).
CONTROLFILE_INCLUDED	VARCHAR2 (7)	Possible values are NONE (backup set does not include a backup control file), BACKUP (backup set includes a normal backup control file), and STANDBY (backup set includes a standby control file).
INPUT_FILE_SCAN_ONLY	VARCHAR2 (3)	This backup set record was created by the BACKUP VALIDATE command. No real backup set exists. This record is only a placeholder used to keep track of which data files were scanned and which corrupt blocks (if any) were found in those files.  If COMPATIBLE is set to 11.0.0 or greater, then RMAN does not populate this column.
KEEP	VARCHAR2 (3)	Indicates whether this backup set has a retention policy different from the value for CONFIGURE RETENTION POLICY. Possible values are YES and NO.
KEEP_UNTIL	DATE	If the KEEP UNTIL TIME clause of the BACKUP command was specified, then this column shows the date after which this backup becomes obsolete. If the column is NULL and KEEP OPTIONS is not NULL, then the backup never becomes obsolete.
KEEP_OPTIONS	VARCHAR2 (11)	The KEEP options specified for this backup set. Possible values are NOLOGS, BACKUP_LOGS, LOGS, and NULL. NOLOGS indicates a consistent backup made when the database was mounted. BACKUP_LOGS indicates that the backup was made in open mode, so archived log backups must be applied to make it consistent. LOGS indicates a long-term backup made with the LOGS keyword, which is now deprecated. NULL indicates that this backup has no KEEP options and becomes obsolete based on the retention policy.
BLOCK_SIZE	NUMBER	Block size of the backup set.
SITE_KEY	NUMBER	Primary key of the Data Guard database associated with this backup set. Each database in a Data Guard environment has a unique SITE_KEY value. You can use SITE_KEY in a join with the RC_SITE view to obtain the DB_UNIQUE_NAME of the database.
MULTI_SECTION	VARCHAR2 (3)	Y if this is a multisection backup; otherwise null.

## 5.19 RC\_BACKUP\_SET\_DETAILS

RC\_BACKUP\_SET\_DETAILS provides details about currently available backup sets, including backup sets created by the use of the BACKUP BACKUPSET command.

This view is primarily intended to be used internally by Enterprise Manager.

Column	Data Type	Description
SESSION_KEY	NUMBER	Session identifier. Use in joins with RC_RMAN_OUTPUT and RC_RMAN_BACKUP_JOB_DETAILS.
SESSION_RECID	NUMBER	With SESSION_STAMP, uniquely identifies output for this backup job from RC_RMAN_OUTPUT.
SESSION_STAMP	NUMBER	With SESSION_RECID, uniquely identifies output for this backup job from RC_RMAN_OUTPUT.
DB_KEY	NUMBER	The primary key for this database in the recovery catalog. Use this column to join with almost any other catalog view.
DB_NAME	VARCHAR2 (8)	The DB_NAME of the database incarnation to which this record belongs.
BS_KEY	NUMBER	The primary key of the backup set to which this record belongs in the recovery catalog. Use this column to join with RC_BACKUP_SET or RC_BACKUP_PIECE.
RECID	NUMBER	The backup set RECID and STAMP form a concatenated primary key that uniquely identifies this record in the target database control file.
STAMP	NUMBER	The backup set RECID and STAMP form a concatenated primary key that uniquely identifies this record in the target database control file.
SET_STAMP	NUMBER	The SET_STAMP value from V\$BACKUP_SET. SET_STAMP and SET_COUNT form a concatenated key that uniquely identifies this record in the target database control file.
SET_COUNT	NUMBER	The SET_COUNT value from V\$BACKUP_SET. SET_STAMP and SET_COUNT form a concatenated key that uniquely identifies this record in the target database control file.
BACKUP_TYPE	VARCHAR2 (1)	The type of the backup: D (full backup), I ( level 0 incremental or level 1 incremental), L (archived redo log).
CONTROLFILE_INCLUDED	VARCHAR2 (7)	Possible values are NONE (backup set does not include a backup control file), BACKUP (backup set includes a normal backup control file), and STANDBY (backup set includes a standby control file).
INCREMENTAL_LEVEL	NUMBER	The level of the incremental backup: NULL, 0, or 1.

Column	Data Type	Description
PIECES	NUMBER	The number of backup pieces in the backup set.
START_TIME	DATE	The time when the backup began.
COMPLETION_TIME	DATE	The time when the backup completed.
ELAPSED_SECONDS	NUMBER	The duration of the backup in seconds.
BLOCK_SIZE	VARCHAR2	The block size used when creating the backup pieces in the backup set.
KEEP	VARCHAR2 (3)	Indicates whether this backup set has a retention policy different from the value for <code>CONFIGURE RETENTION POLICY</code> . Possible values are <code>YES</code> and <code>NO</code> .
KEEP_UNTIL	DATE	If the <code>KEEP UNTIL TIME</code> clause of the <code>BACKUP</code> command was specified, then this column shows the date after which this backup becomes obsolete. If the column is <code>NULL</code> and <code>KEEP OPTIONS</code> is not <code>NULL</code> , the backup never becomes obsolete.
KEEP_OPTIONS	VARCHAR2 (11)	The <code>KEEP</code> options specified for this backup set. Possible values are <code>NOLOGS</code> , <code>BACKUP_LOGS</code> , <code>LOGS</code> , and <code>NULL</code> . <code>NOLOGS</code> indicates a consistent backup made when the database was mounted. <code>BACKUP_LOGS</code> indicates that the backup was made in open mode, so archived log backups must be applied to make it consistent. <code>LOGS</code> indicates a long-term backup made with the <code>LOGS</code> keyword, which is now deprecated. <code>NULL</code> indicates that this backup has no <code>KEEP</code> options and becomes obsolete based on the retention policy.
DEVICE_TYPE	VARCHAR2 (255)	Device type on which the backup is stored. If the backup set is stored on multiple types of devices (for example, if a backup set on disk is also backed up to tape using <code>BACKUP BACKUPSET</code> ), then this column contains an asterisk (*). Values are <code>DISK</code> or <code>SBT_TAPE</code> .
COMPRESSED	VARCHAR2 (3)	<code>YES</code> if <code>RMAN</code> 's binary compression was used in creating the backup set. <code>NO</code> , otherwise.
NUM_COPIES	NUMBER	Number of identical copies of this backup set created during the backup, for example if duplexing was used.
OUTPUT_BYTES	NUMBER	Sum of sizes of all output pieces generated by this job.
ORIGINAL_INPUT_BYTES	NUMBER	Sum of sizes of all input files backed up for this job.
COMPRESSION_RATIO	NUMBER	Compression ratio for this backup.
STATUS	CHAR (1)	The status of the backup set: always <code>A</code> (all backup pieces available), because this view only reflects available backup sets.
ORIGINAL_INPRATE_BYTES	NUMBER	Number of bytes read each second when the backup set was initially created.



Column	Data Type	Description
OUTPUT_RATE_BYTES	NUMBER	Number of bytes written each second when the backup set was initially created.
ORIGINAL_INPUT_BYTES_DISPLAY	VARCHAR2 (32K)	Same value as ORIGINAL_INPUT_BYTES, but converted to a user-displayable format, for example, 798.01M or 5.25G.
OUTPUT_BYTES_DISPLAY	VARCHAR2 (32K)	Same value as OUTPUT_BYTES, but converted to a user-displayable format, for example, 798.01M or 5.25G.
ORIGINAL_INPRATE_BYTES_DISPLAY	VARCHAR2 (32K)	Same value as ORIGINAL_INPRATE_BYTES, but converted to a user-displayable format, for example, 798.01M or 5.25G.
OUTPUT_RATE_BYTES_DISPLAY	VARCHAR2 (32K)	Same value as OUTPUT_RATE_BYTES, but converted to a user-displayable format, for example, 798.01M or 5.25G.
TIME_TAKEN_DISPLAY	VARCHAR2 (32K)	Same value as ELAPSED_SECONDS, but converted to a user-displayable format in hours, minutes and seconds.
ENCRYPTED	VARCHAR2 (3)	Indicates whether the backup piece is encrypted (YES) or not (NO).
BACKED_BY_OSB	VARCHAR2 (3)	Indicates whether the backup piece is backed up to Oracle Secure Backup (YES) or not (NO).

## 5.20 RC\_BACKUP\_SET\_SUMMARY

RC\_BACKUP\_SET\_SUMMARY provides aggregate information about available backup sets for each database registered in the recovery catalog.

This view is primarily intended to be used internally by Enterprise Manager.

Column	Data Type	Description
DB_NAME	VARCHAR2 (8)	The DB_NAME of the database incarnation to which this record belongs.
DB_KEY	NUMBER	The primary key for this database in the recovery catalog. Use this column to join with almost any other catalog view.
NUM_BACKUPSETS	NUMBER	Total number of available backup sets recorded in the recovery catalog for this database.
OLDEST_BACKUP_TIME	DATE	Creation time of the oldest available backup set recorded in the recovery catalog for this database.
NEWEST_BACKUP_TIME	DATE	Creation time of the newest available backup set recorded in the recovery catalog for this database.
OUTPUT_BYTES	NUMBER	Sum of sizes of all backup pieces for all available backup sets recorded in the recovery catalog for this database.

Column	Data Type	Description
ORIGINAL_INPUT_BYTES	NUMBER	Sum of sizes of all input files for all available backup sets recorded in the recovery catalog for this database.
ORIGINAL_INPRATE_BYTES	NUMBER	Average input rate in bytes for the creation of all available backup sets recorded in the recovery catalog for this database.
OUTPUT_RATE_BYTES	NUMBER	Average output rate in bytes for the creation of all available backup sets recorded in the recovery catalog for this database.
COMPRESSION_RATIO	NUMBER	Aggregate compression ratio for all available backup sets recorded in the recovery catalog for this database.
ORIGINAL_INPUT_BYTES_DISPLAY	VARCHAR2 (32K)	Total size of all input files stored in all available backup sets recorded in the recovery catalog for this database.
OUTPUT_BYTES_DISPLAY	VARCHAR2 (32K)	Same value as OUTPUT_BYTES, but converted to a user-displayable format, for example, 798.01M or 5.25G.
ORIGINAL_INPRATE_BYTES_DISPLAY	VARCHAR2 (32K)	Same value as ORIGINAL_INPRATE_BYTES, but converted to a user-displayable format, for example, 798.01M or 5.25G.
OUTPUT_RATE_BYTES_DISPLAY	VARCHAR2 (32K)	Same value as OUTPUT_RATE_BYTES, but converted to a user-displayable format, for example, 798.01M or 5.25G.

## 5.21 RC\_BACKUP\_SPFILE

This view lists information about server parameter files in backup sets.

Column	Data Type	Description
DB_KEY	NUMBER	The primary key for the target database. Use this column to join with almost any other catalog view.
BSF_KEY	NUMBER	The primary key of the server parameter file in the recovery catalog. If you issue the LIST command while RMAN is connected to the recovery catalog, then this value appears in the KEY column of the output.
RECID	NUMBER	The record identifier propagated from V\$BACKUP_SPFILE. RECID and STAMP form a concatenated primary key that uniquely identifies this record in the target database control file.
STAMP	NUMBER	The stamp from V\$BACKUP_SPFILE. RECID and STAMP form a concatenated primary key that uniquely identifies this record in the target database control file.

Column	Data Type	Description
BS_KEY	NUMBER	The primary key of the backup set to which this record belongs in the recovery catalog. Use this column to join with RC_BACKUP_SET.
SET_STAMP	NUMBER	The SET_STAMP value from V\$BACKUP_SET. SET_STAMP and SET_COUNT form a concatenated key that uniquely identifies the backup set to which this record belongs in the target database control file.
SET_COUNT	NUMBER	The SET_COUNT value from V\$BACKUP_SET. SET_STAMP and SET_COUNT form a concatenated key that uniquely identifies the backup set to which this record belongs in the target database control file.
MODIFICATION_TIME	DATE	The time when the server parameter file was last modified.
STATUS	VARCHAR2 (1)	The status of the backup set: A (all backup pieces available), D (all backup pieces deleted), O (some backup pieces are available but others are not, so the backup set is unusable).
BS_RECID	NUMBER	The RECID value from V\$BACKUP_SET.
BS_STAMP	NUMBER	The STAMP value from V\$BACKUP_SET. BS_STAMP is different from SET_STAMP. BS_STAMP is the stamp of the backup set record when created in the control file, whereas SET_STAMP joins with SET_COUNT to make a unique identifier.
COMPLETION_TIME	DATE	The time when the backup set completed.
BYTES	NUMBER	The size of the backup set in bytes.
DB_UNIQUE_NAME	VARCHAR2 (30)	The DB_UNIQUE_NAME of the database to which this record belongs.

## 5.22 RC\_BACKUP\_SPFILE\_DETAILS

RC\_BACKUP\_SPFILE\_DETAILS provides detailed information about SPFILE backups for each database registered in the recovery catalog.

This view is primarily intended to be used internally by Enterprise Manager.

Column	Data Type	Description
SESSION_KEY	NUMBER	Session identifier. Use in joins with RC_RMAN_OUTPUT and RC_RMAN_BACKUP_JOB_DETAILS.
SESSION_RECID	NUMBER	With SESSION_STAMP, uniquely identifies output for this backup job from RC_RMAN_OUTPUT.
SESSION_STAMP	NUMBER	With SESSION_RECID, uniquely identifies output for this backup job from RC_RMAN_OUTPUT.
DB_KEY	NUMBER	The primary key for this database in the recovery catalog. Use this column to join with almost any other catalog view.

Column	Data Type	Description
DB_NAME	VARCHAR2 (8)	The DB_NAME of the database incarnation to which this record belongs.
BS_KEY	NUMBER	Unique backup set identifier. Use this column to join with RC_BACKUP_SET or RC_BACKUP_PIECE.
SET_STAMP	NUMBER	Set stamp.
SET_COUNT	NUMBER	Set count.
MODIFICATION_TIME	DATE	Modification time.
FILESIZE	NUMBER	Size in bytes of the SPFILE that was backed up.
FILESIZE_DISPLAY	VARCHAR2 (32K)	Same value as FILESIZE, but converted to a user-displayable format, for example, 798.01M or 5.25G.

## 5.23 RC\_BACKUP\_SPFILE\_SUMMARY

RC\_BACKUP\_SPFILE\_SUMMARY provides summary information about server parameter file backups for databases registered in the recovery catalog.

This view is primarily intended to be used internally by Enterprise Manager.

Column	Data Type	Description
DB_NAME	VARCHAR2 (8)	The DB_NAME of the database incarnation to which this record belongs.
DB_KEY	NUMBER	The primary key for this database in the recovery catalog. Use this column to join with almost any other catalog view.
NUM_FILES_BACKED	NUMBER	Number of files backed up.
NUM_DISTINCT_FILES_BACKED	NUMBER	Number of distinct files backed up (based on differing modification timestamps).
MIN_MODIFICATION_TIME	DATE	Earliest modification time of any SPFILE backed up for this database.
MAX_MODIFICATION_TIME	DATE	Latest modification time of any SPFILE backed up for this database.
INPUT_BYTES	NUMBER	Total number of bytes in the input files backed up.
INPUT_BYTES_DISPLAY	VARCHAR2 (32K)	Same value as INPUT_BYTES, but converted to a user-displayable format, for example, 798.01M or 5.25G.

## 5.24 RC\_CHECKPOINT

This view is deprecated. See RC\_RESYNC instead.

## 5.25 RC\_CONTROLFILE\_COPY

This view lists information about control file copies on disk.

A data file copy record with a file number of 0 represents the control file copy in V\$DATAFILE\_COPY.

Column	Data Type	Description
DB_KEY	NUMBER	The primary key for the target database. Use this column to join with almost any other catalog view.
DBINC_KEY	NUMBER	The primary key for the incarnation of the target database. Use this column to join with RC_DATABASE_INCARNATION.
DB_NAME	VARCHAR2 (8)	The DB_NAME of the database incarnation to which this record belongs.
CCF_KEY	NUMBER	The primary key of the control file copy in the recovery catalog. If you issue the LIST command while RMAN is connected to the recovery catalog, then this value appears in the KEY column of the output.
RECID	NUMBER	The record identifier from V\$DATAFILE_COPY. RECID and STAMP form a concatenated primary key that uniquely identifies this record in the target database control file.
STAMP	NUMBER	The stamp from V\$DATAFILE_COPY. RECID and STAMP form a concatenated primary key that uniquely identifies this record in the target database control file.
NAME	VARCHAR2 (1024)	The control file copy file name.
TAG	VARCHAR2 (32)	The tag of the control file copy. NULL if no tag used.
RESETLOGS_CHANGE#	NUMBER	The SCN of the most recent RESETLOGS when the record was created.
RESETLOGS_TIME	DATE	The time stamp of the most recent RESETLOGS when the record was created.
CHECKPOINT_CHANGE#	NUMBER	The control file checkpoint SCN.
CHECKPOINT_TIME	DATE	The control file checkpoint time.
CREATION_TIME	DATE	The control file creation time.
BLOCKS	NUMBER	The number of blocks in the control file.
BLOCK_SIZE	NUMBER	The block size in bytes.
MIN_OFFR_RECID	NUMBER	Internal use only.
OLDEST_OFFLINE_RANGE	NUMBER	Internal use only.
COMPLETION_TIME	DATE	The time when the copy was generated.
STATUS	VARCHAR2 (1)	The status of the copy: A (available), U (unavailable), X (expired), or D (deleted).
CONTROLFILE_TYPE	VARCHAR2 (1)	The type of control file copy: B (normal copy) or S (standby copy).
KEEP	VARCHAR2 (3)	Indicates whether this copy has a retention policy different from the value for CONFIGURE RETENTION POLICY. Possible values are YES and NO.

Column	Data Type	Description
KEEP_UNTIL	DATE	If the <code>KEEP UNTIL TIME</code> clause of the <code>COPY</code> command was specified, then this column shows the date after which this file becomes obsolete. If the column is <code>NULL</code> and <code>KEEP OPTIONS</code> is not <code>NULL</code> , the file never becomes obsolete.
KEEP_OPTIONS	VARCHAR2 (11)	The <code>KEEP</code> options specified for this control file copy. Possible values are <code>NOLOGS</code> , <code>BACKUP_LOGS</code> , <code>LOGS</code> , and <code>NULL</code> . <code>NOLOGS</code> indicates a consistent backup made when the database was mounted. <code>BACKUP_LOGS</code> indicates that the backup was made in open mode, so archived log backups must be applied to make it consistent. <code>LOGS</code> indicates a long-term backup made with the <code>LOGS</code> keyword, which is now deprecated. <code>NULL</code> indicates that this backup has no <code>KEEP</code> options and becomes obsolete based on the retention policy.
IS_RECOVERY_DEST_FILE	VARCHAR2 (3)	This copy is located in the fast recovery area: <code>YES</code> or <code>NO</code> .
RSR_KEY	NUMBER	Unique key for the row in <code>RC_RMAN_STATUS</code> that created this backup piece.
SITE_KEY	NUMBER	Primary key of the Data Guard database associated with this file. Each database in a Data Guard environment has a unique <code>SITE_KEY</code> value. You can use <code>SITE_KEY</code> in a join with the <code>RC_SITE</code> view to obtain the <code>DB_UNIQUE_NAME</code> of the database.

## 5.26 RC\_COPY\_CORRUPTION

This view lists corrupt block ranges in data file copies. It corresponds to the `V$COPY_CORRUPTION` view.

Column	Data Type	Description
DB_KEY	NUMBER	The primary key for the target database. Use this column to join with almost any other catalog view.
DBINC_KEY	NUMBER	The primary key for the incarnation of the target database. Use this column to join with <code>RC_DATABASE_INCARNATION</code> .
DB_NAME	VARCHAR2 (8)	The <code>DB_NAME</code> of the database incarnation to which this record belongs.
RECID	NUMBER	The record identifier from <code>V\$COPY_CORRUPTION</code> . <code>RECID</code> and <code>STAMP</code> form a concatenated primary key that uniquely identifies this record in the target database control file.

Column	Data Type	Description
STAMP	NUMBER	The stamp from V\$COPY_CORRUPTION.RECID and STAMP form a concatenated primary key that uniquely identifies this record in the target database control file.
CDF_KEY	NUMBER	The primary key of the data file copy in the recovery catalog. If you issue the LIST command while RMAN is connected to the recovery catalog, then this value appears in the KEY column of the output. Use this column to join with RC_DATAFILE_COPY.
COPY_RECID	NUMBER	The RECID from RC_DATAFILE_COPY. This value is propagated from the control file.
COPY_STAMP	NUMBER	The STAMP from RC_DATAFILE_COPY. This value is propagated from the control file.
FILE#	NUMBER	The absolute file number of the data file.
CREATION_CHANGE#	NUMBER	The creation SCN of this data file. Because file numbers can be reused, FILE# and CREATION_CHANGE# are both required to uniquely identify a specified file over the life of the database.
BLOCK#	NUMBER	The block number of the first corrupted block in the file.
BLOCKS	NUMBER	The number of corrupted blocks found beginning with BLOCK#.
CORRUPTION_CHANGE#	NUMBER	For media corrupt blocks, this value is zero. For logically corrupt blocks, this value is the lowest SCN in the blocks in this corrupt range.
MARKED_CORRUPT	VARCHAR2 (3)	YES if this corruption was not previously detected by the database server or NO if it was known by the database server.
CORRUPTION_TYPE	VARCHAR2 (9)	Same as RC_DATABASE_BLOCK_CORRUPTION.CORRUPTION_TYPE.

## 5.27 RC\_DATABASE

This view gives information about the databases registered in the recovery catalog. It corresponds to the V\$DATABASE view.

Column	Data Type	Description
DB_KEY	NUMBER	The primary key for the database. Use this column to join with almost any other catalog view.
DBINC_KEY	NUMBER	The primary key for the current incarnation. Use this column to join with RC_DATABASE_INCARNATION.
DBID	NUMBER	Unique identifier for the database obtained from V\$DATABASE.

Column	Data Type	Description
NAME	VARCHAR2 (8)	The DB_NAME of the database for the current incarnation.
RESETLOGS_CHANGE#	NUMBER	The SCN of the RESETLOGS of the current database incarnation.
RESETLOGS_TIME	DATE	The timestamp of the RESETLOGS of the current database incarnation.
FINAL_CHANGE#	NUMBER	The highest SCN to which a database can be recovered when using backups and redo logs available on Zero Data Loss Recovery Appliance (Recovery Appliance). Use this value in the SET UNTIL SCN clause while recovering a database after the loss of all data files and online redo log files. <b>See Also:</b> <i>Zero Data Loss Recovery Appliance Protected Database Configuration Guide</i>

## 5.28 RC\_DATABASE\_BLOCK\_CORRUPTION

This view gives information about database blocks that were corrupted after the last backup. It corresponds to the V\$DATABASE\_BLOCK\_CORRUPTION view, which is populated in real time with corruption information.

Column	Data Type	Description
DB_KEY	NUMBER	The primary key for the database. Use this column to join with almost any other catalog view.
DBINC_KEY	NUMBER	The primary key for the current incarnation. Use this column to join with RC_DATABASE_INCARNATION.
FILE#	NUMBER	The absolute file number of the data file.
BLOCK#	NUMBER	The block number of the first corrupted block in this range of corrupted blocks.
BLOCKS	NUMBER	The number of corrupted blocks found beginning with BLOCK#.
CORRUPTION_CHANGE#	NUMBER	For media corrupt blocks, this value is zero. For logically corrupt blocks, this value is the lowest SCN in the blocks in this corrupt range.



Column	Data Type	Description
CORRUPTION_TYPE	VARCHAR2 (9)	<p>The type of block corruption in the data file. Possible values are:</p> <ul style="list-style-type: none"> <li>• <b>ALL ZERO.</b> The block header on disk contained only zeros. The block may be valid if it was never filled and if it is in an Oracle7 file. The buffer is reformatted to the Oracle8 standard for an empty block.</li> <li>• <b>FRACTURED.</b> The block header looks reasonable, but the front and back of the block are different versions.</li> <li>• <b>CHECKSUM.</b> The optional check value shows that the block is not self-consistent. It is impossible to determine exactly why the check value fails, but it probably fails because sectors in the middle of the block are from different versions.</li> <li>• <b>CORRUPT.</b> The block is wrongly identified or is not a data block (for example, the data block address is missing)</li> <li>• <b>LOGICAL.</b> Specifies the range for logically corrupt blocks.</li> <li>• <b>NOLOGGING.</b> The block does not have redo log entries (for example, <b>NOLOGGING</b> operations on primary database can introduce this type of corruption on a physical standby)</li> </ul>

## 5.29 RC\_DATABASE\_INCARNATION

This view lists information about all database incarnations registered in the recovery catalog.

Oracle creates a new incarnation whenever you open a database with the **RESETLOGS** option. Records about the current and immediately previous incarnation are also contained in the **V\$DATABASE** view.

Column	Data Type	Description
DB_KEY	NUMBER	The primary key for the database. Use this column to join with almost any other catalog view.
DBID	NUMBER	Unique identifier for the database.
DBINC_KEY	NUMBER	The primary key for the incarnation.
GUID	RAW (16)	Globally unique identifier (GUID) of this PDB.
NAME	VARCHAR2 (8)	The <b>DB_NAME</b> for the database at the time of the <b>RESETLOGS</b> . The value is <b>UNKNOWN</b> if you have done at least one <b>RESETLOGS</b> before registering the target database with <b>RMAN</b> , because <b>RMAN</b> does not know the <b>DB_NAME</b> before the <b>RESETLOGS</b> .

Column	Data Type	Description
REG_DB_UNIQUE_NAME	VARCHAR2 (30)	DB_UNIQUE_NAME of the database that registered this database.
RESETLOGS_CHANGE#	NUMBER	The SCN of the RESETLOGS operation that created this incarnation.
RESETLOGS_TIME	DATE	The time stamp of the RESETLOGS operation that created this incarnation.
CURRENT_INCARNATION	VARCHAR2 (3)	YES if it is the current incarnation; NO if it is not.
PARENT_DBINC_KEY	NUMBER	The DBINC_KEY of the previous incarnation for this database. The value is NULL if it is the first incarnation recorded for the database.
PRIOR_RESETLOGS_CHANGE#	NUMBER	The SCN of the RESETLOGS operation that created the parent of this incarnation.
PRIOR_RESETLOGS_TIME	DATE	The time stamp of the RESETLOGS operation that created the parent of this incarnation.
STATUS	VARCHAR2 (8)	CURRENT if this incarnation is the current database incarnation. PARENT if this is a noncurrent incarnation that is a direct ancestor of the current incarnation. ORPHAN if this is a noncurrent incarnation that is not a direct ancestor of the current incarnation.
CON_ID	NUMBER	ID of the container to which the data pertains. Possible values include: <ul style="list-style-type: none"> <li>• 0: Rows containing data that pertain to the whole multitenant container database (CDB)</li> <li>• 1: Rows containing data that pertains only to the root</li> <li>• <i>n</i>: Where <i>n</i> is the applicable container ID for the rows containing data</li> </ul>

## 5.30 RC\_DATAFILE

This view lists information about all data files registered in the recovery catalog. It corresponds to the V\$DATAFILE view.

A data file is shown as dropped if its tablespace was dropped.

Column	Data Type	Description
DB_KEY	NUMBER	The primary key for this database in the recovery catalog. Use this column to join with almost any other catalog view.
DBINC_KEY	NUMBER	The primary key for the incarnation of the target database. Use this column to join with RC_DATABASE_INCARNATION.
DB_NAME	VARCHAR2 (8)	The DB_NAME of the database incarnation to which this record belongs.

Column	Data Type	Description
CON_ID	NUMBER	The ID of the container to which the data pertains. Possible values include: <ul style="list-style-type: none"> <li>0: Rows containing data that pertain to the entire multitenant container database (CDB)</li> <li>1: Rows containing data that pertains only to the root</li> <li><i>n</i>: Where <i>n</i> is the applicable container ID for the rows containing data</li> </ul>
PDB_NAME	VARCHAR2 (31)	Name of the pluggable database (PDB) in the recovery catalog.
PDB_KEY	NUMBER	The primary key for this PDB in the recovery catalog.
PDBINC_KEY	NUMBER	The primary key for the incarnation of the PDB.
TS#	NUMBER	The number of the tablespace to which the data file belongs. The TS# may exist multiple times in the same incarnation if the tablespace is dropped and re-created.
TABLESPACE_NAME	VARCHAR2 (30)	The tablespace name. The name may exist multiple times in the same incarnation if the tablespace is dropped and re-created.
FILE#	NUMBER	The absolute file number of the data file. The same data file number may exist multiple times in the same incarnation if the data file is dropped and re-created.
CREATION_CHANGE#	NUMBER	The SCN at data file creation.
CREATION_TIME	DATE	The time of data file creation.
DROP_CHANGE#	NUMBER	The SCN recorded when the data file was dropped. If a new data file with the same file number is discovered, then the DROP_CHANGE# is set to CREATION_CHANGE# for the data file; otherwise the value is set to RC_CHECKPOINT.CKP_SCN.
DROP_TIME	DATE	The time when the data file was dropped. If a new data file with the same file number is discovered, then the DROP_TIME is set to CREATION_TIME for the data file; otherwise the value is set to RC_CHECKPOINT.CKP_TIME.
BYTES	NUMBER	The size of the data file in bytes.
BLOCKS	NUMBER	The size of the data file in blocks.
BLOCK_SIZE	NUMBER	The size of the data blocks in bytes.
NAME	VARCHAR2 (1024)	The data file name.
STOP_CHANGE#	NUMBER	For offline or read-only data files, the SCN value such that no changes in the redo stream at an equal or greater SCN apply to this file.
STOP_TIME	DATE	For offline normal or read-only data files, the time beyond which there are no changes in the redo stream that apply to this data file.
READ_ONLY	NUMBER	1 if the file is read-only; otherwise 0.

Column	Data Type	Description
RFILE#	NUMBER	The relative file number of this data file within its tablespace.
INCLUDED_IN_DATABASE_BACKUP	VARCHAR2 (3)	Indicates whether this tablespace is included in whole database backups: YES or NO. The NO value occurs only if CONFIGURE EXCLUDE was run on the tablespace that owns this data file.
AUX_NAME	VARCHAR2 (1024)	Indicates the auxiliary name for the data file as set by CONFIGURE AUXNAME.
ENCRYPT_IN_BACKUP	VARCHAR2 (3)	YES if this data file has been configured to be transparently encrypted when backed up; otherwise NULL.
SITE_KEY	NUMBER	Primary key of the Data Guard database associated with this file. Each database in a Data Guard environment has a unique SITE_KEY value. You can use SITE_KEY in a join with the RC_SITE view to obtain the DB_UNIQUE_NAME of the database.
DB_UNIQUE_NAME	VARCHAR2 (512)	The DB_UNIQUE_NAME of the database incarnation to which this record belongs. All databases in a Data Guard environment share the same DBID but different DB_UNIQUE_NAME values. The value in this column is null when the database name is not known for a specific file. For example, rows for databases managed by versions of RMAN before Oracle Database 11g are null.
FOREIGN_DBID	NUMBER	Foreign DBID from which this data file came from. The value is 0 if this file is not a foreign database file.
FOREIGN_CREATION_CHANGE#	NUMBER	Creation SCN of a foreign data file. The value is 0 if this file is not a foreign database file.
FOREIGN_CREATION_TIME	DATE	Creation time of a foreign data file. The value is 0 if this file is not a foreign database file.
PLUGGED_READONLY	VARCHAR2 (3)	YES if this is a transported read-only foreign file; otherwise NO.
PLUGIN_CHANGE#	NUMBER	SCN at which the foreign data file was transported into the database. The value is 0 if this file is not a foreign database file.
PLUGIN_RESETLOGS_CHANGE#	NUMBER	The SCN of the RESETLOGS operation for the incarnation into which this foreign file was transported. The value is 0 if this file is not a foreign database file.
PLUGIN_RESETLOGS_TIME	DATE	The time of the RESETLOGS operation for the incarnation into which this foreign file was transported. The value is 0 if this file is not a foreign database file.
CREATION_THREAD	NUMBER	The thread number of the data file describe by this row.
CREATION_SIZE	NUMBER	The size of the data file at the time of creation.

## 5.31 RC\_DATAFILE\_COPY

This view lists information about data file copies on disk. It corresponds to the `V$DATAFILE_COPY` view.

Column	Data Type	Description
DB_KEY	NUMBER	The primary key for the target database. Use this column to join with almost any other catalog view.
DBINC_KEY	NUMBER	The primary key for the incarnation of the target database. Use this column to join with <code>RC_DATABASE_INCARNATION</code> .
PDB_KEY	NUMBER	The primary key of the PDB in the recovery catalog. Use this column to identify the PDB that owns the data file copies.
DB_NAME	VARCHAR2 (8)	The <code>DB_NAME</code> of the database incarnation to which this record belongs.
CDF_KEY	NUMBER	The primary key of the data file copy in the recovery catalog. If you issue the <code>LIST</code> command while <code>RMAN</code> is connected to the recovery catalog, then this value appears in the <code>KEY</code> column of the output.
RECID	NUMBER	The data file copy record from <code>V\$DATAFILE_COPY</code> . <code>RECID</code> and <code>STAMP</code> form a concatenated primary key that uniquely identifies this record in the target database control file.
STAMP	NUMBER	The data file copy stamp from <code>V\$DATAFILE_COPY</code> . <code>RECID</code> and <code>STAMP</code> form a concatenated primary key that uniquely identifies this record in the target database control file.
NAME	VARCHAR2 (1024)	The file name of the data file copy.
TAG	VARCHAR2 (32)	The tag for the data file copy.
FILE#	NUMBER	The absolute file number for the data file.
CREATION_CHANGE#	NUMBER	The creation SCN of the data file.
CREATION_TIME	DATE	Data file creation timestamp.
RESETLOGS_CHANGE#	NUMBER	The SCN of the most recent <code>RESETLOGS</code> when the data file was created.
RESETLOGS_TIME	DATE	The time stamp of the most recent <code>RESETLOGS</code> in the data file header.
INCREMENTAL_LEVEL	NUMBER	The incremental level of the copy: 0 or <code>NULL</code> .
CHECKPOINT_CHANGE#	NUMBER	The SCN of the most recent data file checkpoint.
CHECKPOINT_TIME	DATE	The time of the most recent data file checkpoint.
ABSOLUTE_FUZZY_CHANGE#	NUMBER	The highest SCN in any block of the file, if known. Recovery must proceed to at least this SCN for the file to become not fuzzy.

Column	Data Type	Description
RECOVERY_FUZZY_CHANGE#	NUMBER	The SCN to which recovery must proceed for the file to become not fuzzy. If not <code>NULL</code> , this file must be recovered at least to the specified SCN before the database can be opened with this file.
RECOVERY_FUZZY_TIME	DATE	The time that is associated with the <code>RECOVERY_FUZZY_CHANGE#</code> .
ONLINE_FUZZY	VARCHAR2 (3)	YES/NO. If set to <code>YES</code> , this copy was made after an instance failure or <code>OFFLINE IMMEDIATE</code> (or is a copy that was taken improperly while the database was open). Recovery applies all redo up to the next crash recovery marker to make the file consistent.
BACKUP_FUZZY	VARCHAR2 (3)	YES/NO. If set to <code>YES</code> , this is a copy taken using the <code>BEGIN BACKUP/END BACKUP</code> technique. To make this copy consistent, the recovery process needs to apply all redo up to the marker that is placed in the redo stream when the <code>ALTER TABLESPACE END BACKUP</code> command is used.
BLOCKS	NUMBER	The number of blocks in the data file copy (also the size of the data file when the copy was made).
BLOCK_SIZE	NUMBER	The size of the blocks in bytes.
COMPLETION_TIME	DATE	The time when the copy completed.
STATUS	VARCHAR2 (1)	The status of the copy: <code>A</code> (available), <code>U</code> (unavailable), <code>X</code> (expired), or <code>D</code> (deleted).
KEEP	VARCHAR2 (3)	Indicates whether this copy has a retention policy different from the value for <code>CONFIGURE RETENTION POLICY</code> . Possible values are <code>YES</code> and <code>NO</code> .
KEEP_UNTIL	DATE	If the <code>KEEP UNTIL TIME</code> clause of the <code>COPY</code> command was specified, then this column shows the date after which this data file copy becomes obsolete. If the column is <code>NULL</code> and <code>KEEP OPTIONS</code> is not <code>NULL</code> , the copy never becomes obsolete.
KEEP_OPTIONS	VARCHAR2 (11)	The <code>KEEP</code> options specified for this data file copy. Possible values are <code>NOLOGS</code> , <code>BACKUP_LOGS</code> , <code>LOGS</code> , and <code>NULL</code> . <code>NOLOGS</code> indicates a consistent backup made when the database was mounted. <code>BACKUP_LOGS</code> indicates that the backup was made in open mode, so archived log backups must be applied to make it consistent. <code>LOGS</code> indicates a long-term backup made with the <code>LOGS</code> keyword, which is now deprecated. <code>NULL</code> indicates that this backup has no <code>KEEP</code> options and becomes obsolete based on the retention policy.

Column	Data Type	Description
SCANNED	VARCHAR2 (3)	<p>Whether RMAN scanned the file (YES or NO). If YES, then this copy was created by a server process that examined every block in the file, for example, by the RMAN COPY or RESTORE command. If NO, then RMAN did not examine every block in the file, as when RMAN inspects a non-RMAN generated image copy or restores by proxy copy.</p> <p>Whenever RMAN creates or restores a data file copy, it adds rows to the V\$DATABASE_BLOCK_CORRUPTION view and RC_DATABASE_BLOCK_CORRUPTION view if it discovers corrupt blocks in the file. If RMAN has scanned the entire file, then the absence of corruption records for this copy means that no corrupt blocks exist in the file. If RMAN did not scan the file, then the absence of corruption records means that corrupt blocks may or may not exist in the file.</p>
IS_RECOVERY_DEST_FILE	VARCHAR2 (3)	This data file copy is located in the fast recovery area: YES or NO.
RSR_KEY	NUMBER	Unique key for the row in RC_RMAN_STATUS that created this backup piece.
MARKED_CORRUPT	NUMBER	The number of blocks that were discovered to be corrupt during the course of this backup. These blocks were reformatted as known-corrupt blocks in the output image copy.
SITE_KEY	NUMBER	Primary key of the Data Guard database associated with this file. Each database in a Data Guard environment has a unique SITE_KEY value. You can use SITE_KEY in a join with the RC_SITE view to obtain the DB_UNIQUE_NAME of the database.
DB_UNIQUE_NAME	VARCHAR2 (512)	The DB_UNIQUE_NAME of the database incarnation to which this record belongs. All databases in a Data Guard environment share the same DBID but different DB_UNIQUE_NAME values. The value in this column is null when the database name is not known for a specific file. For example, rows for databases managed by versions of RMAN before Oracle Database 11g are null.
FOREIGN_DBID	NUMBER	Foreign DBID of the database from which this data file was transported. The value is 0 if the file backed up is not a foreign database file.
PLUGGED_READONLY	VARCHAR2 (3)	YES if this is a copy of a transported read-only foreign file; otherwise NO.
PLUGIN_CHANGE#	NUMBER	SCN at which the foreign data file was transported into the database. The value is 0 if this file is not a foreign database file.

Column	Data Type	Description
PLUGIN_RESETLOGS_CHANGE#	NUMBER	The SCN of the RESETLOGS operation for the incarnation into which this foreign file was transported. The value is 0 if this file is not a foreign database file.
PLUGIN_RESETLOGS_TIME	DATE	The time of the RESETLOGS operation for the incarnation into which this foreign file was transported. The value is 0 if this file is not a foreign database file.
SPARSE_BACKUP	VARCHAR2 (3)	Indicates if the backup is a sparse backup

## 5.32 RC\_DISK\_RESTORE\_RANGE

The RC\_DISK\_RESTORE\_RANGE view contains information about the restore range of the database for backup data that is stored on disk. This view corresponds to the V\$DISK\_RESTORE\_RANGE view.

Column	Data Type	Description
DB_KEY	NUMBER	The unique database identifier.
SITE_KEY	NUMBER	The primary key of the database site that is associated with this restore range. Each database in a Data Guard environment has a unique SITE_KEY value. You can use the SITE_KEY in join with the RC_SITE view to obtain the DB_UNIQUE_NAME of the database.
LOW_TIME	DATE	The earliest time to which the database can be restored.
HIGH_TIME	DATE	The latest time to which the database can be restored.
LOW_SCN	NUMBER	The lowest SCN to which the database can be restored.
HIGH_SCN	NUMBER	The highest SCN to which the database can be restored.
LOW_DBINC_KEY	NUMBER	The primary key for the incarnation of the database to which LOW_SCN belongs.
HIGH_DBINC_KEY	NUMBER	The primary key for the incarnation of the database to which HIGH_SCN belongs.

## 5.33 RC\_LOG\_HISTORY

This view lists historical information about the online redo logs.

RMAN adds a new row during a catalog resynchronization whenever Oracle has switched out of the online redo log. This catalog view corresponds to the V\$LOG\_HISTORY view.



Column	Data Type	Description
DB_KEY	NUMBER	The primary key for the target database. Use this column to join with almost any other catalog view.
DBINC_KEY	NUMBER	The primary key for the incarnation of the target database. Use this column to join with RC_DATABASE_INCARNATION.
DB_NAME	VARCHAR2 (8)	The DB_NAME of the database incarnation to which this record belongs.
RECID	NUMBER	The redo log history RECID from V\$LOG_HISTORY. RECID and STAMP form a concatenated primary key that uniquely identifies this record in the target database control file.
STAMP	NUMBER	The redo log history stamp from V\$LOG_HISTORY. RECID and STAMP form a concatenated primary key that uniquely identifies this record in the target database control file.
THREAD#	NUMBER	The thread number of the online redo log.
SEQUENCE#	NUMBER	The log sequence number of the redo log.
FIRST_CHANGE#	NUMBER	The SCN generated when switching into the redo log.
FIRST_TIME	DATE	The time stamp when switching into the redo log.
NEXT_CHANGE#	NUMBER	The first SCN of the next redo log in the thread.
CLEARED	VARCHAR2 (3)	YES if the redo log was cleared with the ALTER DATABASE CLEAR LOGFILE statement; otherwise, NULL. This statement allows a log to be dropped without archiving it first.

## 5.34 RC\_OFFLINE\_RANGE

This view lists the offline ranges for data files. It corresponds to the V\$OFFLINE\_RANGE view.

An offline range is created for a data file when its tablespace is first altered to be offline normal or read-only, and then subsequently altered to be online or read/write. No offline range is created if the data file itself is altered to be offline or if the tablespace is altered to be offline immediate.

Column	Data Type	Description
DB_KEY	NUMBER	The primary key for the target database. Use this column to join with almost any other catalog view.
DBINC_KEY	NUMBER	The primary key for the incarnation of the target database. Use this column to join with RC_DATABASE_INCARNATION.
DB_NAME	VARCHAR2 (8)	The DB_NAME of the database incarnation to which this record belongs.

Column	Data Type	Description
RECID	NUMBER	The record identifier for the offline range from V\$OFFLINE_RANGE. RECID and STAMP form a concatenated primary key that uniquely identifies this record in the target database control file.
STAMP	NUMBER	The stamp for the offline range from V\$OFFLINE_RANGE. RECID and STAMP form a concatenated primary key that uniquely identifies this record in the target database control file.
FILE#	NUMBER	The absolute file number of the data file.
CREATION_CHANGE#	NUMBER	The SCN at data file creation.
OFFLINE_CHANGE#	NUMBER	The SCN taken when the data file was taken offline.
ONLINE_CHANGE#	NUMBER	The online checkpoint SCN.
ONLINE_TIME	DATE	The online checkpoint time.
CF_CREATE_TIME	DATE	The time of control file creation.
RESETLOGS_CHANGE#	NUMBER	The SCN of the most recent RESETLOGS in the data file header.
RESETLOGS_TIME	DATE	The time corresponding to RESETLOGS_CHANGE#.
OFFR_KEY	NUMBER	The primary key of the offline range record in the recovery catalog.

## 5.35 RC\_PDBS

This view provides information about the pluggable databases (PDBs) registered in the recovery catalog. It corresponds to the V\$PDBS view.

Column	Data Type	Description
PDB_KEY	NUMBER	The primary key for this PDB in the recovery catalog.
DB_KEY	NUMBER	The primary key for the multitenant container database (CDB) in the recovery catalog. Use this column to join with almost any other catalog view.
NAME	VARCHAR2	Name of the PDB.
CON_ID	NUMBER	Unique identifier of the CDB.
DBID	NUMBER	Unique identifier of the PDB.
GUID	RAW(16)	Globally unique identifier (GUID) of this PDB.
CREATION_CHANGE#	NUMBER	SCN at which the PDB was created.

## 5.36 RC\_PLUGGABLE\_DATABASE\_INC

RC\_PLUGGABLE\_DATABASE\_INC displays information about all pluggable database (PDB) incarnations.

A new PDB incarnation is created whenever a PDB is opened with the `RESETLOGS` option. This view corresponds to the `V$PDB_INCARNATION` view.

Column	Data Type	Description
PDB_KEY	NUMBER	The primary key for this PDB in the recovery catalog.
NAME	VARCHAR2 (30)	Name of the PDB.
CON_ID	NUMBER	Unique identifier of the multitenant container database (CDB) that contains this PDB.
DBID	NUMBER	Unique identifier of the PDB.
GUID	RAW (16)	Globally unique identifier (GUID) of this PDB.
CREATE_SCN	NUMBER	Creation SCN of PDB.
PDBINC_KEY	NUMBER	The primary key for this PDB incarnation in recovery catalog.
DB_KEY	NUMBER	The primary key for this CDB in the recovery catalog.
CURRENT_INCARNATION	VARCHAR2 (3)	YES if it is the current incarnation; NO if it is not.
INCARNATION_SCN	NUMBER	The SCN to flashback or recover to for this PDB incarnation.
BEGIN_RESETLOGS_SCN	NUMBER	The SCN at the beginning of the PDB resetlogs.
BEGIN_RESETLOGS_TIME	DATE	The time of the SCN in <code>BEGIN_RESETLOGS_SCN</code> .
END_RESETLOGS_SCN	NUMBER	The SCN at the end of the PDB resetlogs.
DBINC_KEY	NUMBER	The primary key for the incarnation of CDB at which this PDB incarnation is created.
DB_RESETLOGS_SCN	NUMBER	The incarnation SCN of CDB at which this PDB incarnation is created.
DB_RESETLOGS_TIME	DATE	The incarnation time of CDB at which this PDB incarnation is created.
PRIOR_PDBINC_KEY	NUMBER	The primary key of the parent PDB incarnation.
PRIOR_INCARNATION_SCN	NUMBER	INCARNATION_SCN of parent PDB incarnation.
PRIOR_BEGIN_RESETLOGS_SCN	NUMBER	BEGIN_RESETLOGS_SCN of parent PDB incarnation
PRIOR_BEGIN_RESETLOGS_TIME	DATE	BEGIN_RESETLOGS_TIME of parent PDB incarnation.
PRIOR_END_RESETLOGS_TIME	NUMBER	END_RESETLOGS_TIME of parent PDB incarnation.
PRIOR_DBINC_KEY	NUMBER	DBINC_KEY of parent PDB incarnation.
PRIOR_DB_RESETLOGS_SCN	NUMBER	DB_RESETLOGS_SCN of parent PDB incarnation
PRIOR_DB_RESETLOGS_TIME	DATE	DB_RESETLOGS_TIME of parent PDB incarnation
STATUS	VARCHAR2 (8)	Incarnation status: <ul style="list-style-type: none"> <li>• ORPHAN: Orphan incarnation</li> <li>• CURRENT: Current incarnation of the PDB</li> <li>• PARENT: Parent of current incarnation</li> </ul>

## 5.37 RC\_PROXY\_ARCHIVEDLOG

This view contains descriptions of archived log backups that were taken using the proxy copy functionality. It corresponds to the `V$PROXY_ARCHIVEDLOG` view.

In a proxy copy, the media manager takes over the operations of backing up and restoring data. Each row represents a backup of one control file.

Column	Data Type	Description
DB_KEY	NUMBER	The primary key for the target database. Use this column to join with almost any other catalog view.
DBINC_KEY	NUMBER	The primary key for the incarnation of the target database. Use this column to join with <code>RC_DATABASE_INCARNATION</code> .
DB_NAME	VARCHAR2 (8)	The <code>DB_NAME</code> of the database incarnation to which this record belongs.
XAL_KEY	NUMBER	The proxy copy primary key in the recovery catalog. If you issue the <code>LIST</code> command while <code>RMAN</code> is connected to the recovery catalog, then this value appears in the <code>KEY</code> column of the output.
RECID	NUMBER	The proxy copy record identifier from <code>V\$PROXY_ARCHIVEDLOG</code> . <code>RECID</code> and <code>STAMP</code> form a concatenated primary key that uniquely identifies this record in the target database control file.
STAMP	NUMBER	The proxy copy stamp from <code>V\$PROXY_ARCHIVEDLOG</code> . <code>RECID</code> and <code>STAMP</code> form a concatenated primary key that uniquely identifies this record in the target database control file.
TAG	VARCHAR2 (32)	The tag for the proxy copy.
DEVICE_TYPE	VARCHAR2 (255)	The type of media device that stores the proxy copy.
HANDLE	VARCHAR2 (1024)	The name or "handle" for the proxy copy. <code>RMAN</code> passes this value to the media manager that created the proxy copy of the archived redo log.
COMMENTS	VARCHAR2 (255)	Comments about the proxy copy.
MEDIA	VARCHAR2 (80)	A comment that contains further information about the media manager that created this backup.
MEDIA_POOL	NUMBER	The number of the media pool in which the proxy copy is stored.
STATUS	VARCHAR2 (1)	The status of the backup set: <code>A</code> (available), <code>U</code> (unavailable), <code>X</code> (expired), or <code>D</code> (deleted).
THREAD#	NUMBER	The number of the redo thread.
SEQUENCE#	NUMBER	The log sequence number.
RESETLOGS_CHANGE#	NUMBER	The <code>RESETLOGS</code> SCN of the database incarnation to which this archived log belongs.

Column	Data Type	Description
RESETLOGS_TIME	DATE	The RESETLOGS time stamp of the database incarnation to which this archived log belongs.
FIRST_CHANGE#	NUMBER	The first SCN of this redo log.
FIRST_TIME	DATE	The time when Oracle switched into the redo log.
NEXT_CHANGE#	NUMBER	The first SCN of the next redo log in the thread.
NEXT_TIME	DATE	The first time stamp of the next redo log in the thread.
BLOCKS	NUMBER	The size of this archived redo log in operating system blocks.
BLOCK_SIZE	NUMBER	The block size for the copy in bytes.
DEVICE_TYPE	VARCHAR2 (255)	The type of sequential media device.
START_TIME	DATE	The time when proxy copy was initiated.
COMPLETION_TIME	DATE	The time when the proxy copy was completed.
ELAPSED_SECONDS	NUMBER	The duration of the proxy copy.
RSR_KEY	NUMBER	The primary key from the RMAN status record. Use this column to perform a join with RC_RMAN_STATUS.
TERMINAL	VARCHAR2 (3)	YES if this record corresponds to a terminal archived redo log, as defined in V\$ARCHIVED_LOG.
KEEP	VARCHAR2 (3)	Indicates whether this proxy copy has a retention policy different from the value for CONFIGURE RETENTION POLICY. Possible values are YES and NO.
KEEP_OPTIONS	VARCHAR2 (11)	The KEEP options specified for this proxy copy. Possible values are NOLOGS, BACKUP_LOGS, LOGS, and NULL. NOLOGS indicates a consistent backup made when the database was mounted. BACKUP_LOGS indicates that the backup was made in open mode, so archived log backups must be applied to make it consistent. LOGS indicates a long-term backup made with the LOGS keyword, which is now deprecated. NULL indicates that this backup has no KEEP options and becomes obsolete based on the retention policy.
KEEP_UNTIL	DATE	If the KEEP UNTIL TIME clause of the BACKUP command was specified, then this column shows the date after which this proxy copy becomes obsolete. If the column is NULL and KEEP_OPTIONS is not NULL, then the proxy copy never becomes obsolete.
SITE_KEY	NUMBER	Primary key of the Data Guard database associated with this file. Each database in a Data Guard environment has a unique SITE_KEY value. You can use SITE_KEY in a join with the RC_SITE view to obtain the DB_UNIQUE_NAME of the database.

## 5.38 RC\_PROXY\_ARCHIVELOG\_DETAILS

RC\_PROXY\_ARCHIVELOG\_DETAILS provides detailed information about proxy copy backups of archived redo log for each database registered in the recovery catalog.

This view shows one record for each database registered in the recovery catalog. Thus, if only one database is registered, then this view shows one row regardless of the number of proxy copies of archived redo log files that have been performed. This view is primarily intended to be used internally by Enterprise Manager.

Column	Data Type	Description
SESSION_KEY	NUMBER	Session identifier. Use in joins with RC_RMAN_OUTPUT and RC_RMAN_BACKUP_JOB_DETAILS.
SESSION_RECID	NUMBER	With SESSION_STAMP, uniquely identifies output for this backup job from RC_RMAN_OUTPUT.
SESSION_STAMP	NUMBER	With SESSION_RECID, uniquely identifies output for this backup job from RC_RMAN_OUTPUT.
DB_KEY	NUMBER	The primary key for this database in the recovery catalog. Use this column to join with almost any other catalog view.
DB_NAME	VARCHAR2 (8)	The DB_NAME of the database incarnation to which this record belongs.
COPY_KEY	NUMBER	Unique identifier for this proxy copy.
THREAD#	NUMBER	Redo thread number for the archived redo log file that was backed up.
SEQUENCE#	NUMBER	Log sequence number for the archived redo log file that was backed up.
RESETLOGS_CHANGE#	NUMBER	Checkpoint SCN of OPEN RESETLOGS for incarnation of the database of the archived redo log file that was backed up.
RESETLOGS_TIME	DATE	Time corresponding to RESETLOGS_CHANGE#.
HANDLE	VARCHAR2 (1024)	A file name for the proxy copy.
MEDIA	VARCHAR2 (80)	A comment that contains further information about the media manager that created this backup.
MEDIA_POOL	NUMBER	The number of the media pool in which the backup is stored.
TAG	VARCHAR2 (32)	Tag specified for this backup.
FIRST_CHANGE#	NUMBER	First change SCN included in the archived redo log file.
NEXT_CHANGE#	NUMBER	Next change SCN after this archived redo log file.
FIRST_TIME	DATE	Time corresponding to FIRST_CHANGE#.
NEXT_TIME	DATE	Time corresponding to NEXT_CHANGE#.
OUTPUT_BYTES	NUMBER	Sum of sizes of all output pieces generated by this job.

Column	Data Type	Description
COMPLETION_TIME	DATE	The time at which the job was completed.
OUTPUT_BYTES_DISPLAY	VARCHAR2 (32K)	Same value as OUTPUT_BYTES, but converted to a user-displayable format, for example, 798.01M or 5.25G.

## 5.39 RC\_PROXY\_ARCHIVELOG\_SUMMARY

RC\_PROXY\_ARCHIVELOG\_SUMMARY contains a summary of proxy copy backups of archived redo log files.

This view is primarily intended to be used internally by Enterprise Manager.

Column	Data Type	Description
DB_NAME	VARCHAR2 (8)	The DB_NAME of the database incarnation to which this record belongs.
DB_KEY	NUMBER	The primary key for this database in the recovery catalog. Use this column to join with almost any other catalog view.
NUM_FILES_BACKED	NUMBER	Total number of archived redo log files backed up.
NUM_DISTINCT_FILES_BACKED	NUMBER	Number of distinct archived redo log files backed up.
MIN_FIRST_CHANGE#	NUMBER	Minimum value for the first SCN of any redo log file in this summary.
MAX_NEXT_CHANGE#	NUMBER	Maximum value for the NEXT_CHANGE# SCN of any redo log file in this summary.
MIN_FIRST_TIME	DATE	Minimum value for the time of the first change in any redo log. Along with MAX_NEXT_TIME, forms the redo range.
MAX_NEXT_TIME	DATE	Maximum value for the time of the next change after any redo logs in this session.
OUTPUT_BYTES	NUMBER	Sum of sizes of all output pieces generated by this job.
OUTPUT_BYTES_DISPLAY	VARCHAR2 (32K)	Same value as OUTPUT_BYTES, but converted to a user-displayable format, for example, 798.01M or 5.25G.

## 5.40 RC\_PROXY\_CONTROLFILE

This view contains descriptions of control file backups that were taken using the proxy copy functionality. It corresponds to the V\$PROXY\_DATAFILE view.

In a proxy copy, the media manager takes over the operations of backing up and restoring data. Each row represents a backup of one control file.

Column	Data Type	Description
DB_KEY	NUMBER	The primary key for the target database. Use this column to join with almost any other catalog view.
DBINC_KEY	NUMBER	The primary key for the incarnation of the target database. Use this column to join with RC_DATABASE_INCARNATION.
DB_NAME	VARCHAR2 (8)	The DB_NAME of the database incarnation to which this record belongs.
XCF_KEY	NUMBER	The proxy copy primary key in the recovery catalog. If you issue the LIST command while RMAN is connected to the recovery catalog, then this value appears in the KEY column of the output.
RECID	NUMBER	The proxy copy record identifier from V\$PROXY_DATAFILE. RECID and STAMP form a concatenated primary key that uniquely identifies this record in the target database control file.
STAMP	NUMBER	The proxy copy stamp from V\$PROXY_DATAFILE.RECID and STAMP form a concatenated primary key that uniquely identifies this record in the target database control file.
TAG	VARCHAR2 (32)	The tag for the proxy copy.
RESETLOGS_CHANGE#	NUMBER	The RESETLOGS SCN of the database incarnation to which this data file belongs.
RESETLOGS_TIME	DATE	The RESETLOGS time stamp of the database incarnation to which this data file belongs.
CHECKPOINT_CHANGE#	NUMBER	Data file checkpoint SCN when this copy was made.
CHECKPOINT_TIME	DATE	Data file checkpoint time when this copy was made.
CREATION_TIME	DATE	The control file creation time.
BLOCK_SIZE	NUMBER	The block size for the copy in bytes.
BLOCKS	NUMBER	The number of blocks in the copy.
MIN_OFFR_RECID	NUMBER	Internal use only.
OLDEST_OFFLINE_RANGE	NUMBER	Internal use only.
DEVICE_TYPE	VARCHAR2 (255)	The type of sequential media device.
HANDLE	VARCHAR2 (1024)	The name or "handle" for the proxy copy. RMAN passes this value to the operating system-dependent layer that identifies the file.
COMMENTS	VARCHAR2 (255)	Comments about the proxy copy.
MEDIA	VARCHAR2 (80)	A comment that contains further information about the media manager that created this backup.
MEDIA_POOL	NUMBER	The number of the media pool in which the proxy copy is stored.



Column	Data Type	Description
START_TIME	DATE	The time when proxy copy was initiated.
COMPLETION_TIME	DATE	The time when the proxy copy was completed.
ELAPSED_SECONDS	NUMBER	The duration of the proxy copy.
STATUS	VARCHAR2 (1)	The status of the backup set: A (available), U (unavailable), X (expired), or D (deleted).
KEEP	VARCHAR2 (3)	Indicates whether this proxy copy has a retention policy different from the value for CONFIGURE RETENTION POLICY. Possible values are YES and NO.
KEEP_OPTIONS	VARCHAR2 (11)	The KEEP options specified for this control file backup. Possible values are NOLOGS, BACKUP_LOGS, LOGS, and NULL. NOLOGS indicates a consistent backup made when the database was mounted. BACKUP_LOGS indicates that the backup was made in open mode, so archived log backups must be applied to make it consistent. LOGS indicates a long-term backup made with the LOGS keyword, which is now deprecated. NULL indicates that this backup has no KEEP options and becomes obsolete based on the retention policy.
KEEP_UNTIL	DATE	If the KEEP UNTIL TIME clause of the BACKUP command was specified, then this column shows the date after which this control file backup becomes obsolete. If the column is NULL and KEEP_OPTIONS is not NULL, the backup never becomes obsolete.
CONTROLFILE_TYPE	VARCHAR2 (1)	The type of control file copy: B (normal copy) or S (standby copy).
RSR_KEY	NUMBER	Unique key for the row in RC_RMAN_STATUS that created this backup piece.
SITE_KEY	NUMBER	Primary key of the Data Guard database associated with this file. Each database in a Data Guard environment has a unique SITE_KEY value. You can use SITE_KEY in a join with the RC_SITE view to obtain the DB_UNIQUE_NAME of the database.

## 5.41 RC\_PROXY\_COPY\_DETAILS

RC\_PROXY\_COPY\_DETAILS contains detailed information about proxy copy backups for databases registered in the recovery catalog.

This view is primarily intended to be used internally by Enterprise Manager.

Column	Data Type	Description
SESSION_KEY	NUMBER	Session identifier. Use in joins with RC_RMAN_OUTPUT and RC_RMAN_BACKUP_JOB_DETAILS.

Column	Data Type	Description
SESSION_RECID	NUMBER	With SESSION_STAMP, uniquely identifies output for this proxy copy operation from RC_RMAN_OUTPUT.
SESSION_STAMP	NUMBER	With SESSION_RECID, uniquely identifies output for this proxy copy operation from RC_RMAN_OUTPUT.
DB_KEY	NUMBER	The primary key for this database in the recovery catalog. Use this column to join with almost any other catalog view.
DB_NAME	VARCHAR2 (8)	The DB_NAME of the database incarnation to which this record belongs.
RSR_KEY	NUMBER	Unique key for the row in RC_RMAN_STATUS corresponding to the job that created this proxy copy.
COPY_KEY	NUMBER	Unique identifier for this proxy copy.
FILE#	NUMBER	The absolute file number of the data file that is proxy copied.
HANDLE	VARCHAR2 (1024)	The proxy copy handle identifies the copy for purposes of restore operations.
COMMENTS	VARCHAR2 (255)	A comment that contains further information about the media manager that stores this backup.
MEDIA	VARCHAR2 (80)	Identifies the media manager that stores this backup.
MEDIA_POOL	NUMBER	The number of the media pool in which the copy is stored. This is the same value that was entered in the POOL operand of the Recovery Manager BACKUP command.
TAG	VARCHAR2 (32)	Tag associated with this proxy copy.
CREATION_CHANGE#	NUMBER	The data file creation SCN.
CREATION_TIME	DATE	The time corresponding to CREATION_CHANGE#.
CHECKPOINT_CHANGE#	NUMBER	Checkpoint SCN when the proxy copy was made.
CHECKPOINT_TIME	DATE	The time corresponding to CHECKPOINT_CHANGE#.
OUTPUT_BYTES	NUMBER	Sum of sizes of all output pieces generated by this proxy copy operation.
COMPLETION_TIME	DATE	Time when the proxy copy was completed.
CONTROLFILE_TYPE	VARCHAR2 (1)	Possible values are: B for a normal control file, and S for a standby control file.
KEEP	VARCHAR2 (3)	Indicates whether this backup has a retention policy different from the value for CONFIGURE RETENTION POLICY. Possible values are YES and NO.

Column	Data Type	Description
KEEP_UNTIL	DATE	If the <code>KEEP UNTIL TIME</code> clause was specified, then this column shows the date after which this backup becomes obsolete. If the column is <code>NULL</code> and <code>KEEP OPTIONS</code> is not <code>NULL</code> , the backup never becomes obsolete.
KEEP_OPTIONS	VARCHAR2 (11)	The <code>KEEP</code> options specified for this backup. Possible values are <code>NOLOGS</code> , <code>BACKUP_LOGS</code> , <code>LOGS</code> , and <code>NULL</code> . <code>NOLOGS</code> indicates a consistent backup made when the database was mounted. <code>BACKUP_LOGS</code> indicates that the backup was made in open mode, so archived log backups must be applied to make it consistent. <code>LOGS</code> indicates a long-term backup made with the <code>LOGS</code> keyword, which is now deprecated. <code>NULL</code> indicates that this backup has no <code>KEEP</code> options and becomes obsolete based on the retention policy.
OUTPUT_BYTES_DISPLAY	VARCHAR2 (32K)	Same value as <code>OUTPUT_BYTES</code> , but converted to a user-displayable format, for example, 798.01M or 5.25G.

## 5.42 RC\_PROXY\_COPY\_SUMMARY

`RC_PROXY_COPY_SUMMARY` contains aggregate information about all available proxy copy backups for databases registered in the recovery catalog.

This view is primarily intended to be used internally by Enterprise Manager.

Column	Data Type	Description
DB_KEY	NUMBER	The primary key for this database.
DB_NAME	VARCHAR2 (8)	The <code>DB_NAME</code> of the database incarnation to which this record belongs.
NUM_COPIES	NUMBER	Number of copies created by all proxy copy operations for this database.
NUM_DISTINCT_COPIES	NUMBER	Number of distinct copies created by all proxy copy operations for this database.
MIN_CHECKPOINT_CHANGE#	NUMBER	Minimum checkpoint SCN among any proxy copies for this database.
MAX_CHECKPOINT_CHANGE#	NUMBER	Maximum checkpoint SCN among any proxy copies for this database.
MIN_CHECKPOINT_TIME	DATE	The oldest checkpoint time among any proxy copies for this database.
MAX_CHECKPOINT_TIME	DATE	The most recent checkpoint time among any proxy copies for this database.
OUTPUT_BYTES	NUMBER	Sum of sizes of all output files generated by proxy copies.
OUTPUT_BYTES_DISPLAY	VARCHAR2 (32K)	Same value as <code>OUTPUT_BYTES</code> , but converted to a user-displayable format, for example, 798.01M or 5.25G.

## 5.43 RC\_PROXY\_DATAFILE

This view contains descriptions of data file backups that were taken using the proxy copy functionality. It corresponds to the `V$PROXY_DATAFILE` view.

In a proxy copy, the media manager takes over the operations of backing up and restoring data. Each row represents a backup of one database file.

Column	Data Type	Description
DB_KEY	NUMBER	The primary key for the target database. Use this column to join with almost any other catalog view.
DBINC_KEY	NUMBER	The primary key for the incarnation of the target database. Use this column to join with <code>RC_DATABASE_INCARNATION</code> .
DB_NAME	VARCHAR2 (8)	The <code>DB_NAME</code> of the database incarnation to which this record belongs.
PDB_KEY	NUMBER	The primary key of the PDB in the recovery catalog. Use this column to identify the PDB that owns the proxy copies.
XDF_KEY	NUMBER	The proxy copy primary key in the recovery catalog. If you issue the <code>LIST</code> command while <code>RMAN</code> is connected to the recovery catalog, then this value appears in the <code>KEY</code> column of the output.
RECID	NUMBER	The proxy copy record identifier from <code>V\$PROXY_DATAFILE</code> . <code>RECID</code> and <code>STAMP</code> form a concatenated primary key that uniquely identifies this record in the target database control file.
STAMP	NUMBER	The proxy copy stamp from <code>V\$PROXY_DATAFILE</code> . <code>RECID</code> and <code>STAMP</code> form a concatenated primary key that uniquely identifies this record in the target database control file.
TAG	VARCHAR2 (32)	The tag for the proxy copy.
FILE#	NUMBER	The absolute file number of the data file that is proxy copied.
CREATION_CHANGE#	NUMBER	The data file creation SCN.
CREATION_TIME	DATE	The data file creation time.
RESETLOGS_CHANGE#	NUMBER	The SCN of the most recent <code>RESETLOGS</code> in the data file header.
RESETLOGS_TIME	DATE	The time stamp of the most recent <code>RESETLOGS</code> in the data file header.
INCREMENTAL_LEVEL	NUMBER	0 if this copy is part of an incremental backup strategy, otherwise <code>NULL</code> .
CHECKPOINT_CHANGE#	NUMBER	Checkpoint SCN when the copy was made.
CHECKPOINT_TIME	DATE	Checkpoint time when the copy was made.

Column	Data Type	Description
ABSOLUTE_FUZZY_CHANGE#	NUMBER	The highest SCN in any block of the file, if known. Recovery must proceed to at least this SCN for the file to become not fuzzy.
RECOVERY_FUZZY_CHANGE#	NUMBER	The SCN to which recovery must proceed for the file to become not fuzzy. If not NULL, this file must be recovered at least to the specified SCN before the database can be opened with this file.
RECOVERY_FUZZY_TIME	DATE	The time that is associated with the RECOVERY_FUZZY_CHANGE#.
ONLINE_FUZZY	VARCHAR2 (3)	YES/NO. If set to YES, this copy was made after an instance failure or OFFLINE IMMEDIATE (or is a copy of a copy which was taken improperly while the database was open). Recovery must apply all redo up to the next crash recovery marker to make the file consistent.
BACKUP_FUZZY	VARCHAR2 (3)	YES/NO. If set to YES, this is a copy taken using the BEGIN BACKUP/END BACKUP backup method. To make this copy consistent, recovery must apply all redo up to the marker that is placed in the redo stream when the ALTER TABLESPACE END BACKUP statement is issued.
BLOCKS	NUMBER	Size of the data file copy in blocks (also the size of the data file when the copy was made).
BLOCK_SIZE	NUMBER	The block size for the copy in bytes.
DEVICE_TYPE	VARCHAR2 (255)	The type of sequential media device.
HANDLE	VARCHAR2 (1024)	The name or "handle" for the proxy copy. RMAN passes this value to the operating system-dependent layer that identifies the file.
COMMENTS	VARCHAR2 (255)	Comments about the proxy copy.
MEDIA	VARCHAR2 (80)	A comment that contains further information about the media manager that created this backup.
MEDIA_POOL	NUMBER	The number of the media pool in which the proxy copy is stored.
START_TIME	DATE	The time when proxy copy was initiated.
COMPLETION_TIME	DATE	The time when the proxy copy was completed.
ELAPSED_SECONDS	NUMBER	The duration of the proxy copy.
STATUS	VARCHAR2 (1)	The status of the backup set: A (available), U (unavailable), X (expired), or D (deleted).
KEEP	VARCHAR2 (3)	Indicates whether this proxy copy has a retention policy different from the value for CONFIGURE RETENTION POLICY (YES or NO).
KEEP_UNTIL	DATE	If the KEEP UNTIL TIME clause of the BACKUP command was specified, then this column shows the date after which this data file backup becomes obsolete. If the column is NULL and KEEP OPTIONS is not NULL, the backup never becomes obsolete.

Column	Data Type	Description
KEEP_OPTIONS	VARCHAR2 (11)	The KEEP options specified for this backup. Possible values are NOLOGS, BACKUP_LOGS, LOGS, and NULL. NOLOGS indicates a consistent backup made when the database was mounted. BACKUP_LOGS indicates that the backup was made in open mode, so archived log backups must be applied to make it consistent. LOGS indicates a long-term backup made with the LOGS keyword, which is now deprecated. NULL indicates that this backup has no KEEP options and becomes obsolete based on the retention policy.
RSR_KEY	NUMBER	Unique key for the row in RC_RMAN_STATUS corresponding to the job that created this proxy copy.
SITE_KEY	NUMBER	Primary key of the Data Guard database associated with this file. Each database in a Data Guard environment has a unique SITE_KEY value. You can use SITE_KEY in a join with the RC_SITE view to obtain the DB_UNIQUE_NAME of the database.
FOREIGN_DBID	NUMBER	Foreign DBID of the database from which this data file was transported. The value is 0 if the file backed up is not a foreign database file.
PLUGGED_READONLY	VARCHAR2 (3)	YES if this is a proxy copy of a transported read-only foreign file; otherwise NO.
PLUGIN_CHANGE#	NUMBER	SCN at which the foreign data file was transported into the database. The value is 0 if this file is not a foreign database file.
PLUGIN_RESETLOGS_CHANGE#	NUMBER	The SCN of the RESETLOGS operation for the incarnation into which this foreign file was transported. The value is 0 if this file is not a foreign database file.
PLUGIN_RESETLOGS_TIME	DATE	The time of the RESETLOGS operation for the incarnation into which this foreign file was transported. The value is 0 if this file is not a foreign database file.

## 5.44 RC\_REDO\_LOG

This view lists information about the online redo logs for all incarnations of the database since the last catalog resynchronization. This view corresponds to a join of the V\$LOG and V\$LOGFILE views.

Column	Data Type	Description
DB_KEY	NUMBER	The primary key for the target database. Use this column to join with almost any other catalog view.

Column	Data Type	Description
DBINC_KEY	NUMBER	The primary key for the incarnation of the target database. Use this column to join with RC_DATABASE_INCARNATION.
DB_NAME	VARCHAR2 (8)	The DB_NAME of the database incarnation to which this record belongs.
THREAD#	NUMBER	The number of the redo thread.
GROUP#	NUMBER	The number of the online redo log group.
NAME	VARCHAR2 (1024)	The name of the online redo log file.
SITE_KEY	NUMBER	Primary key of the Data Guard database associated with this file. Each database in a Data Guard environment has a unique SITE_KEY value. You can use SITE_KEY in a join with the RC_SITE view to obtain the DB_UNIQUE_NAME of the database.
BYTES	NUMBER	The size of the file in bytes.
TYPE	VARCHAR2 (7)	The type of redo log: ONLINE or STANDBY.

## 5.45 RC\_REDO\_THREAD

This view lists data about all redo threads for all incarnations of the database since the last catalog resynchronization. This view corresponds to V\$THREAD.

Column	Data Type	Description
DB_KEY	NUMBER	The primary key for the target database. Use this column to join with almost any other catalog view.
DBINC_KEY	NUMBER	The primary key for the incarnation of the target database. Use this column to join with RC_DATABASE_INCARNATION.
DB_NAME	VARCHAR2 (8)	The DB_NAME of the database incarnation to which this record belongs.
THREAD#	NUMBER	The redo thread number for the database incarnation.
STATUS	VARCHAR2 (1)	The status of the redo thread: D (disabled), E (enabled), or O (open).
SEQUENCE#	NUMBER	The last allocated log sequence number.
ENABLE_CHANGE#	NUMBER	The SCN at which this thread was enabled.
ENABLE_TIME	DATE	The time at which this thread was enabled.
DISABLE_CHANGE#	NUMBER	The most recent SCN at which this thread was disabled. If the thread is still disabled, then no redo at or beyond this SCN exists for this thread. If the thread is now enabled, then no redo exists between the DISABLE_CHANGE# and the ENABLE_CHANGE# for this thread.
DISABLE_TIME	DATE	The most recent time at which this thread was disabled.

## 5.46 RC\_RESTORE\_POINT

This view lists all restore points for all incarnations of the database since the last catalog resynchronization. This view corresponds to `V$RESTORE_POINT`.

Column	Data Type	Description
DBINC_KEY	NUMBER	The primary key for the incarnation of the target database. Use this column to join with <code>RC_DATABASE_INCARNATION</code> .
RECID	NUMBER	The recid of the corresponding row in the control file.
STAMP	NUMBER	The timestamp of the row in the control file. (Because control file records are reused, you must combine the timestamp and recid to get a value unique across all records in <code>RC_RMAN_STATUS</code> .)
SITE_KEY	NUMBER	Primary key of the Data Guard database associated with this restore point. Each database in a Data Guard environment has a unique <code>SITE_KEY</code> value. You can use <code>SITE_KEY</code> in a join with the <code>RC_SITE</code> view to obtain the <code>DB_UNIQUE_NAME</code> of the database.
NAME	VARCHAR2 (128)	The name of the restore point.
RESTORE_POINT_TIME	DATE	The database time associated with the restore point SCN.
CREATION_TIME	DATE	The date when the restore point was created.
SCN	NUMBER	The database SCN when the restore point was created
LONG_TERM	VARCHAR2 (3)	YES if the restore point is associated with a backup created with the <code>KEEP</code> option specified; otherwise NO.
PRESERVED	VARCHAR2 (3)	YES if the restore point must be explicitly deleted; otherwise NO.
GUARANTEE_FLASHBACK_DATABASE	VARCHAR2 (3)	YES if the flashback logs must be retained to guarantee a flashback to this point; otherwise NO.
PDB_KEY	NUMBER	The primary key of the PDB in the recovery catalog.
CLEAN	VARCHAR2 (3)	Indicates whether the restore point is a clean PDB restore point . Possible values are YES or NO.

## 5.47 RC\_RESTORE\_RANGE

The `RC_RESTORE_RANGE` view contains details about the restore range of databases registered in the recovery catalog.

Because a database can have multiple restore ranges, this view can contain multiple rows for a single database. This view corresponds to the `V$RESTORE_RANGE` view.



Column	Data Type	Description
DB_KEY	NUMBER	The unique database identifier.
SITE_KEY	NUMBER	The primary key of the database site that is associated with this restore range. Each database in a Data Guard environment has a unique <code>SITE_KEY</code> value. You can use the <code>SITE_KEY</code> in join with the <code>RC_SITE</code> view to obtain the <code>DB_UNIQUE_NAME</code> of the database.
LOW_TIME	DATE	The earliest time to which the database can be restored.
HIGH_TIME	DATE	The latest time to which the database can be restored.
LOW_SCN	NUMBER	The lowest SCN to which the database can be restored.
HIGH_SCN	NUMBER	The highest SCN to which the database can be restored.
LOW_DBINC_KEY	NUMBER	The primary key for the incarnation of the database to which <code>LOW_SCN</code> belongs.
HIGH_DBINC_KEY	NUMBER	The primary key for the incarnation of the database to which <code>HIGH_SCN</code> belongs.

## 5.48 RC\_RESYNC

This view lists information about recovery catalog resynchronizations. Every full resynchronization takes a snapshot of the target database control file and resynchronizes the recovery catalog from the snapshot.

Column	Data Type	Description
DB_KEY	NUMBER	The primary key for the target database. Use this column to join with almost any other catalog view.
DBINC_KEY	NUMBER	The primary key for the incarnation of the target database. Use this column to join with <code>RC_DATABASE_INCARNATION</code> .
DB_NAME	VARCHAR2 (8)	The <code>DB_NAME</code> of the database incarnation to which this record belongs.
RESYNC_KEY	NUMBER	The primary key for the resynchronization.
CONTROLFILE_CHANGE#	NUMBER	The control file checkpoint SCN from which the catalog was resynchronized.
CONTROLFILE_TIME	DATE	The control file checkpoint time stamp from which the catalog was resynchronized.
CONTROLFILE_SEQUENCE#	NUMBER	The control file sequence number.
CONTROLFILE_VERSION	DATE	The creation time for the version of the control file from which the catalog was resynchronized.
RESYNC_TYPE	VARCHAR2 (7)	The type of resynchronization: <code>FULL</code> or <code>PARTIAL</code> .
DB_STATUS	VARCHAR2 (7)	The status of the target database: <code>OPEN</code> or <code>MOUNTED</code> .

Column	Data Type	Description
RESYNC_TIME	DATE	The time of the resynchronization.

## 5.49 RC\_RMAN\_BACKUP\_JOB\_DETAILS

RC\_RMAN\_BACKUP\_JOB\_DETAILS provides detailed information on RMAN backup jobs.

An RMAN job is the set of commands executed within an RMAN session. An RMAN backup job is the set of `BACKUP` commands executed in one RMAN job. For example, a `BACKUP DATABASE and BACKUP ARCHIVELOG ALL` command executed in the same RMAN job compose a single RMAN backup job.

This view contains one row for each RMAN session, even if multiple `BACKUP` commands are executed in the same session. The `SESSION_KEY` column is the unique key for the RMAN session in which the backup job occurred. Details for operations performed during an RMAN session are available in the [RC\\_RMAN\\_BACKUP\\_SUBJOB\\_DETAILS](#) view.

This view is primarily intended to be used internally by Enterprise Manager.

Column	Data Type	Description
DB_KEY	NUMBER	The primary key for this database.
DB_NAME	VARCHAR2 (8)	The <code>DB_NAME</code> of the database incarnation to which this record belongs.
SESSION_KEY	NUMBER	Identifier for the RMAN session. Use in joins with <code>RC_RMAN_OUTPUT</code> and <code>RC_RMAN_BACKUP_JOB_DETAILS</code> .
SESSION_RECID	NUMBER	With <code>SESSION_KEY</code> and <code>SESSION_STAMP</code> , used to uniquely identify job's output from <code>RC_RMAN_OUTPUT</code>
SESSION_STAMP	NUMBER	With <code>SESSION_RECID</code> and <code>SESSION_KEY</code> , used to uniquely identify job's output from <code>RC_RMAN_OUTPUT</code>
COMMAND_ID	VARCHAR2 (33)	Either a user-specified value set using <code>SET COMMAND ID</code> , or an RMAN-generated unique command id.
START_TIME	DATE	Start time of the first backup command in the RMAN job.
END_TIME	DATE	End time of the last backup command in the RMAN job.
INPUT_BYTES	NUMBER	Sum of sizes of all input files backed up during this RMAN job.
OUTPUT_BYTES	NUMBER	Sum of sizes of all output backup pieces generated by this RMAN job.
STATUS_WEIGHT	NUMBER	Used internally by Enterprise Manager.
OPTIMIZED_WEIGHT	NUMBER	Used internally by Enterprise Manager.
INPUT_TYPE_WEIGHT	NUMBER	Used internally by Enterprise Manager.
OUTPUT_DEVICE_TYPE	VARCHAR2 (17)	<code>DISK</code> , <code>SBT_TAPE</code> , or <code>*</code> . An asterisk indicates a backup job that wrote its output to multiple device types.

Column	Data Type	Description
AUTOBACKUP_COUNT	NUMBER	Number of autobackups performed by this RMAN job.
BACKED_BY_OSB	VARCHAR2 (3)	Indicates whether the backup piece is backed up to Oracle Secure Backup (YES) or not (NO).
AUTOBACKUP_DONE	VARCHAR2 (3)	YES or NO, depending upon whether a control file autobackup was done as part of this backup job.
STATUS	VARCHAR2 (23)	<p>One of the following values: RUNNING, RUNNING WITH WARNINGS, RUNNING WITH ERRORS, COMPLETED, COMPLETED WITH WARNINGS, COMPLETED WITH ERRORS, FAILED.</p> <p>A failed job does not mean that no backup sets were created. It is possible that the job failed after RMAN created some backup sets. Thus, the RC_BACKUP_SET_DETAILS view may contain rows describing backup sets created successfully by the backup job. You can join this view with RC_BACKUP_SET_DETAILS to obtain more information about the failed backup job.</p>
INPUT_TYPE	VARCHAR2 (13)	<p>Contains a value indicating the type of input for this backup. For possible values, see the RC_RMAN_BACKUP_TYPE view.</p> <p>If a job includes backups corresponding to multiple values, then multiple rows appear in the view, corresponding to the different INPUT_TYPE values for each type of input, with corresponding values for the INPUT_BYTES, OUTPUT_BYTES, INPUT_BYTES_DISPLAY, OUTPUT_BYTES_DISPLAY fields.</p>
OPTIMIZED	VARCHAR2 (3)	YES or NO, depending on whether backup optimization was applied.
ELAPSED_SECONDS	NUMBER	Number of seconds elapsed during execution of this backup job.
COMPRESSION_RATIO	NUMBER	Compression ratio for this backup.
INPUT_BYTES_PER_SEC	NUMBER	Input read rate, in bytes/second.
OUTPUT_BYTES_PER_SEC	NUMBER	Output write rate, in bytes/second.
INPUT_BYTES_DISPLAY	VARCHAR2 (32K)	Same value as INPUT_BYTES, but converted to a user-displayable format, for example, 798.01M or 5.25G.
OUTPUT_BYTES_DISPLAY	VARCHAR2 (32K)	Same value as OUTPUT_BYTES, but converted to a user-displayable format, for example, 798.01M or 5.25G.
INPUT_BYTES_PER_SEC_DISPLAY	VARCHAR2 (32K)	Same value as INPUT_BYTES_PER_SEC, but converted to a user-displayable format, for example, 798.01M or 5.25G.
OUTPUT_BYTES_PER_SEC_DISPLAY	VARCHAR2 (32K)	Same value as OUTPUT_BYTES_PER_SEC, but converted to a user-displayable format, for example, 798.01M or 5.25G.
TIME_TAKEN_DISPLAY	VARCHAR2 (32K)	Total time for the RMAN job, converted to a user-displayable format, such as hh:mm:ss.

## 5.50 RC\_RMAN\_BACKUP\_SUBJOB\_DETAILS

RC\_RMAN\_BACKUP\_SUBJOB\_DETAILS provides details for groups of similar operations within an RMAN session.

This view is primarily intended to be used internally by Enterprise Manager.

Column	Data Type	Description
DB_KEY	NUMBER	The primary key for this database.
DB_NAME	VARCHAR2 (8)	The DB_NAME of the database incarnation to which this record belongs.
SESSION_KEY	NUMBER	Session identifier. Use in joins with RC_RMAN_OUTPUT and RC_RMAN_BACKUP_JOB_DETAILS.
SESSION_RECID	NUMBER	With SESSION_KEY and SESSION_STAMP, used to uniquely identify the job output from RC_RMAN_OUTPUT.
SESSION_STAMP	NUMBER	With SESSION_RECID and SESSION_KEY, used to uniquely identify the job output from RC_RMAN_OUTPUT.
OPERATION	VARCHAR2 (33)	The possible values are BACKUP, ROLLFORWARD, VALIDATE, or BACKUPSET. For each operation type in a session, the view contains one row with each value representing all operations of that type during the session.
COMMAND_ID	VARCHAR2 (33)	Either a user-specified value set using SET COMMAND ID, or an RMAN-generated unique command id.
START_TIME	DATE	Start time of the first backup command in the job
END_TIME	DATE	End time of the last backup job in the job.
INPUT_BYTES	NUMBER	Sum of sizes of all input files backed up during this job.
OUTPUT_BYTES	NUMBER	Sum of sizes of all output pieces generated by this job.
STATUS_WEIGHT	NUMBER	Used internally by Enterprise Manager.
OPTIMIZED_WEIGHT	NUMBER	Used internally by Enterprise Manager.
INPUT_TYPE_WEIGHT	NUMBER	Used internally by Enterprise Manager.
OUTPUT_DEVICE_TYPE	VARCHAR2 (17)	Type of output device: DISK, SBT_TAPE, or *. An asterisk (*) indicates a backup job that wrote its output to multiple device types.
BACKED_BY_OSB	VARCHAR2 (3)	Indicates whether the backup piece is backed up to Oracle Secure Backup (YES) or not (NO).
AUTOBACKUP_DONE	VARCHAR2 (3)	'Whether a control file autobackup was done as part of this job (YES) or not done (NO).

Column	Data Type	Description
STATUS	VARCHAR2 (23)	One of the following values: RUNNING, RUNNING WITH WARNINGS, RUNNING WITH ERRORS, COMPLETED, COMPLETED WITH WARNINGS, COMPLETED WITH ERRORS, FAILED.
INPUT_TYPE	VARCHAR2 (13)	Contains one of the following values: DATABASE FULL, RECOVERY AREA, DATABASE INCR, DATAFILE FULL, DATAFILE INCR, ARCHIVELOG, CONTROLFILE, SPFILE.  If a subjob includes backups corresponding to multiple values, then multiple rows appear in the view, corresponding to the different INPUT_TYPE values for each type of input, with corresponding values for the INPUT_BYTES, OUTPUT_BYTES, INPUT_BYTES_DISPLAY, OUTPUT_BYTES_DISPLAY fields.
OPTIMIZED	VARCHAR2 (3)	If the value of the OPERATION column is BACKUP, then OPTIMIZED is YES or NO, depending on whether backup optimization was applied.
AUTOBACKUP_COUNT	NUMBER	Number of autobackups performed by this job.
COMPRESSION_RATIO	NUMBER	Compression ratio for this backup.
INPUT_BYTES_DISPLAY	VARCHAR2 (32K)	Same value as INPUT_BYTES, but converted to a user-displayable format, for example, 798.01M or 5.25G.
OUTPUT_BYTES_DISPLAY	VARCHAR2 (32K)	Same value as OUTPUT_BYTES, but converted to a user-displayable for example, 798.01M or 5.25G.

## 5.51 RC\_RMAN\_BACKUP\_TYPE

This view contains information used in filtering the other Enterprise Manager views when generating reports on specific backup types.

This view is used internally by Enterprise Manager.

Column	Data Type	Description
WEIGHT	NUMBER	Used internally by Enterprise Manager to set precedence order of different backup types in reports.
INPUT_TYPE	VARCHAR2 (13)	Used internally by Enterprise Manager to represent possible filters used in creating various reporting screens.

## 5.52 RC\_RMAN\_CONFIGURATION

This view lists information about RMAN persistent configuration settings. It corresponds to the V\$RMAN\_CONFIGURATION view.

Column	Data Type	Description
DB_KEY	NUMBER	The primary key for the target database corresponding to this configuration. Use this column to join with almost any other catalog view.
CONF#	NUMBER	A unique key identifying this configuration record within the target database that owns it.
NAME	VARCHAR2 (65)	The type of configuration. All options of CONFIGURE command are valid types except: CONFIGURE EXCLUDE, (described in RC_TABLESPACE), CONFIGURE AUXNAME (described in RC_DATAFILE), and CONFIGURE SNAPSHOT CONTROLFILE (stored only in control file).
VALUE	VARCHAR2 (1025)	The CONFIGURE command setting. For example: RETENTION POLICY TO RECOVERY WINDOW OF 1 DAYS.
DB_UNIQUE_NAME	VARCHAR2 (512)	The DB_UNIQUE_NAME of the database incarnation to which this record belongs. All databases in a Data Guard environment share the same DBID but different DB_UNIQUE_NAME values. The value in this column is null when the database name is not known for a specific file. For example, rows for databases managed by versions of RMAN before Oracle Database 11g are null.
SITE_KEY	NUMBER	Primary key of the Data Guard database associated with this configuration. Each database in a Data Guard environment has a unique SITE_KEY value. You can use SITE_KEY in a join with the RC_SITE view to obtain the DB_UNIQUE_NAME of the database.

## 5.53 RC\_RMAN\_OUTPUT

RC\_RMAN\_OUTPUT corresponds to the control file view V\$RMAN\_OUTPUT. This view is primarily for internal use by Enterprise Manager.

Column	Data Type	Description
DB_KEY	NUMBER	The primary key for the target database. Use this column to join with almost any other catalog view.
RSR_KEY	NUMBER	Unique key for the row in RC_RMAN_STATUS corresponding to the job that created this output.
SESSION_KEY	NUMBER	Session identifier. Use in joins with RC_RMAN_OUTPUT and RC_RMAN_BACKUP_JOB_DETAILS.
RECID	NUMBER	Contains the value displayed in V\$RMAN_OUTPUT.RECID for this database.

Column	Data Type	Description
STAMP	NUMBER	Stamp (used for ordering) of when the row for this line out output was added.
OUTPUT	VARCHAR2 (130)	RMAN output text.

## 5.54 RC\_RMAN\_STATUS

This view contains information about the history of RMAN operations on all databases associated with this recovery catalog. It contains essentially the same information as `V$RMAN_STATUS`, except that it does not contain information about current sessions.

All RMAN operations such as backups, restores, deletion of backups, and so on are logged in this table. The table is organized to show the status of each RMAN session (the invocation of an RMAN client, including all actions taken until the RMAN client exits), operations executed during the session, and recursive operations.

`RC_RMAN_STATUS` also contains the `RSR_KEY`, `PARENT_KEY` and `SESSION_KEY` columns, which do not appear in `V$RMAN_STATUS`.

Column	Data Type	Description
DB_KEY	NUMBER	The primary key for the database. Use this column to join with almost any other catalog view.
DBINC_KEY	NUMBER	The primary key for the database incarnation.
DB_NAME	VARCHAR2 (8)	The <code>DB_NAME</code> of the database incarnation to which this record belongs.
RECID	NUMBER	The recid of the corresponding row in the control file.
STAMP	NUMBER	The timestamp of the row in the control file. (Because control file records are reused, you must combine the timestamp and recid to get a value unique across all records in <code>RC_RMAN_STATUS</code> .)
RSR_KEY	NUMBER	Unique key for this row.
PARENT_KEY	NUMBER	The value of <code>RSR_KEY</code> for the parent row of this row.
SESSION_KEY	NUMBER	The value of <code>RSR_KEY</code> for the session row associated with this row. Use in joins with <code>RC_RMAN_BACKUP_JOB_DETAILS</code> .
ROW_TYPE	VARCHAR2 (33)	This is the type of operation represented by this row. Possible values are: <ul style="list-style-type: none"> <li>• <code>SESSION</code> for rows at level 0</li> <li>• <code>COMMAND</code> for rows at level 1</li> <li>• <code>RECURSIVE OPERATION</code> for rows at level &gt;1</li> </ul>

Column	Data Type	Description
ROW_LEVEL	NUMBER	<p>The level of this row.</p> <ul style="list-style-type: none"> <li>If 0 then this is a session row, that is, ROW_TYPE=SESSION and the row represents an invocation of the RMAN client.</li> <li>If 1 then this row represents a command entered in the RMAN client and executed. ROW_TYPE=COMMAND for rows at level 1.</li> <li>If &gt;1 then this row represents a recursive operation, which is a suboperation of an RMAN command such as a control file autobackup performed with a database backup. ROW_TYPE=RECURSIVE OPERATION for rows at levels &gt;1.</li> </ul>
OPERATION	VARCHAR2 (33)	<p>The name of the operation presented by this row. For SESSION operations, this column is set to RMAN. For COMMAND operations, it describes the command executed, such as BACKUP, RESTORE, CONFIGURE, REPORT and so on.</p>
STATUS	VARCHAR2 (33)	<p>The status of the operation described by this row. Possible values are:</p> <ul style="list-style-type: none"> <li>COMPLETED - Job completed successfully - no warnings or errors during execution.</li> <li>COMPLETED WITH WARNINGS- Job completed successfully, but there were some warning messages during execution. For example, a warning message like the following: <p>RMAN-05019: WARNING: no channel of required type allocated to recover copy of datafile1</p> </li> <li>COMPLETED WITH ERRORS - Job completed successfully, but there were some errors which were overcome using failover features. For example, RESTORE FAILOVER or BACKUP FAILOVER was used to schedule the job on another channel.</li> <li>FAILED - Job failed.</li> <li>RUNNING - Job is executing and there are no errors or warnings during execution so far.</li> <li>RUNNING WITH ERRORS - Job is executing with error messages.</li> <li>RUNNING WITH WARNINGS - Job is executing with warning messages.</li> </ul>
COMMAND_ID	VARCHAR2 (33)	<p>The user-specified ID of the operation. The user can change this using the SET COMMAND ID syntax in RMAN. By default, the command ID is set to the time at which RMAN is invoked, in ISO standard format.</p>
MBYTES_PROCESSED	NUMBER	<p>If the operation represented by this row performed some data transfer (such as backing up or restoring data), then this column contains the number of megabytes processed in the operation. Otherwise, this row contains NULL.</p>



Column	Data Type	Description
START_TIME	DATE	The start time for the operation represented by this row.
END_TIME	DATE	The end time for the operation represented by this row.
JOB_KEY	NUMBER	The key of the RMAN session. Identical to SESSION_KEY.
INPUT_BYTES	NUMBER	Number of input bytes read.
OUTPUT_BYTES	NUMBER	Number of input bytes written.
OPTIMIZED	VARCHAR2 (3)	YES if backup optimization was applied during the backup job. Otherwise, NO.
OBJECT_TYPE	VARCHAR2 (80)	Contains one of the following values: DATABASE FULL, RECOVERY AREA, DATABASE INCR, DATAFILE FULL, DATAFILE INCR, ARCHIVELOG, CONTROLFILE, SPFILE.
SESSION_RECID	NUMBER	If ROW_TYPE=SESSION, that is, this row has no parents and represents an RMAN session, then this column contains NULL. Otherwise, it contains the recid of the row representing the session associated with this row.
SESSION_STAMP	NUMBER	If ROW_TYPE=SESSION, that is, this row has no parents and represents an RMAN session, then this column contains NULL. Otherwise, it contains the timestamp of the row representing the session associated with this row.
OUTPUT_DEVICE_TYPE	VARCHAR2 (17)	The type of output device: DISK, SBT_TAPE, or *. An asterisk (*) indicates that output was written to multiple device types.
SITE_KEY	NUMBER	Primary key of the Data Guard database associated with the RMAN status information. Each database in a Data Guard environment has a unique SITE_KEY value. You can use SITE_KEY in a join with the RC_SITE view to obtain the DB_UNIQUE_NAME of the database.
OSB_ALLOCATED	VARCHAR2 (3)	YES if this session allocated an SBT channel for Oracle Secure Backup; otherwise, NO.

## 5.55 RC\_SBT\_RESTORE\_RANGE

The RC\_SBT\_RESTORE\_RANGE view contains information about the restore range of the database for backup data that is stored on tape.

This view corresponds to the V\$SBT\_RESTORE\_RANGE view.

Column	Data Type	Description
DB_KEY	NUMBER	The unique database identifier.

Column	Data Type	Description
SITE_KEY	NUMBER	The primary key of the database site that is associated with this restore range. Each database in a Data Guard environment has a unique SITE_KEY value. You can use the SITE_KEY in join with the RC_SITE view to obtain the DB_UNIQUE_NAME of the database.
LOW_TIME	DATE	The earliest time to which the database can be restored.
HIGH_TIME	DATE	The latest time to which the database can be restored.
LOW_SCN	NUMBER	The lowest SCN to which the database can be restored.
HIGH_SCN	NUMBER	The highest SCN to which the database can be restored.
LOW_DBINC_KEY	NUMBER	The primary key for the incarnation of the database to which LOW_SCN belongs.
HIGH_DBINC_KEY	NUMBER	The primary key for the incarnation of the database to which HIGH_SCN belongs.

## 5.56 RC\_SITE

This view lists information about all databases in a Data Guard environment that are known to the recovery catalog.

You can use this view to obtain the DB\_UNIQUE\_NAME value for views which do not have this column.

Column	Data Type	Description
SITE_KEY	NUMBER	The unique key of this database. You can join the RC_SITE.SITE_KEY column with the RC_SITE column of other views to determine which DB_UNIQUE_NAME is associated with a backup.
DB_KEY	NUMBER	The primary key for this database in the recovery catalog. Use this column to join with almost any other catalog view.
DATABASE_ROLE	VARCHAR2 (7)	The role of the database in the Data Guard environment.
CF_CREATE_TIME	DATE	The creation date of the control file.
DB_UNIQUE_NAME	VARCHAR2 (30)	The DB_UNIQUE_NAME of the database. All databases in a Data Guard environment share the same DBID but different DB_UNIQUE_NAME values.

## 5.57 RC\_STORED\_SCRIPT

This view lists information about scripts stored in the recovery catalog.

The view contains one row for each stored script. RMAN commands for script management such as `LIST SCRIPT NAMES` and `LIST SCRIPT` provide more convenient ways of viewing this information.

Column	Data Type	Description
DB_KEY	NUMBER	The primary key for the database that owns this stored script. Use this column to join with almost any other catalog view.
DB_NAME	VARCHAR2 (8)	The DB_NAME of the database incarnation to which this record belongs.
SCRIPT_NAME	VARCHAR2 (100)	The name of the stored script.
SCRIPT_COMMENT	VARCHAR2 (255)	The comment that the user entered while creating this script. NULL if no comment was entered.

## 5.58 RC\_STORED\_SCRIPT\_LINE

This view lists information about individual lines of stored scripts in the recovery catalog.

The view contains one row for each line of each stored script.

Column	Data Type	Description
DB_KEY	NUMBER	The primary key for the database that owns this stored script. Use this column to join with almost any other catalog view.
SCRIPT_NAME	VARCHAR2 (100)	The name of the stored script.
LINE	NUMBER	The number of the line in the stored script. Each line of a stored script is uniquely identified by SCRIPT_NAME and LINE.
TEXT	VARCHAR2 (1024)	The text of the line of the stored script.

## 5.59 RC\_TABLESPACE

This view lists all tablespaces registered in the recovery catalog, all dropped tablespaces, and tablespaces that belong to old incarnations.

It corresponds to the `V$TABLESPACE` view. The current value is shown for tablespace attributes.

Column	Data Type	Description
DB_KEY	NUMBER	The primary key for the target database. Use this column to join with almost any other catalog view.
DBINC_KEY	NUMBER	The primary key for the incarnation of the target database. Use this column to join with RC_DATABASE_INCARNATION.
DB_NAME	VARCHAR2 (8)	The DB_NAME of the database incarnation to which this record belongs.

Column	Data Type	Description
CON_ID	NUMBER	The ID of the container to which the data pertains. Possible values include: <ul style="list-style-type: none"> <li>0: Rows containing data that pertain to the entire multitenant container database (CDB)</li> <li>1: Rows containing data that pertains only to the root</li> <li><i>n</i>: Where <i>n</i> is the applicable container ID for the rows containing data</li> </ul>
PDB_NAME	VARCHAR2 (30)	The name of the pluggable database (PDB) in the recovery catalog.
PDB_KEY	NUMBER	The primary key for the PDB in the recovery catalog.
PDBINC_KEY	NUMBER	The primary key for the incarnation of the PDB.
PLUGIN_CHANGE#	NUMBER	SCN at which the foreign tablespace was transported into the database. A value of 0 indicates that this is not a foreign tablespace.
TS#	NUMBER	The tablespace ID in the target database. The TS# may exist multiple times in the same incarnation if the tablespace is dropped and re-created.
NAME	VARCHAR2 (30)	The tablespace name. The name may exist multiple times in the same incarnation if the tablespace is dropped and re-created.
CREATION_CHANGE#	NUMBER	The creation SCN (from the first data file).
CREATION_TIME	DATE	The creation time of the tablespace. NULL for offline tablespaces after creating the control file.
DROP_CHANGE#	NUMBER	The SCN recorded when the tablespace was dropped. If a new tablespace with the same TS# is discovered, then the DROP_CHANGE# is set to CREATION_CHANGE# for the tablespace; otherwise, the value is set to RC_CHECKPOINT.CKP_SCN.
DROP_TIME	DATE	The date when the tablespace was dropped.
INCLUDED_IN_DATABASE_BACKUP	VARCHAR2 (3)	Indicates whether this tablespace is included in whole database backups: YES or NO. The YES value occurs only if CONFIGURE EXCLUDE was run on the tablespace that owns this data file.
BIGFILE	VARCHAR2 (3)	Indicates whether this tablespace is a tablespace created with the BIGFILE option.
TEMPORARY	VARCHAR2 (3)	YES if tablespace is a locally managed temporary tablespace. Otherwise, NO.

Column	Data Type	Description
ENCRYPT_IN_BACKUP	VARCHAR2 (3)	Possible values are: <ul style="list-style-type: none"> <li>• ON. Encryption is turned ON at tablespace level</li> <li>• OFF. Encryption is turned OFF at tablespace level</li> <li>• NULL. Encryption is neither explicitly turned on or off at tablespace level (default or when CLEARED)</li> </ul>

## 5.60 RC\_TEMPFILE

This view lists information about all temp files registered in the recovery catalog.

It corresponds to the `V$tempfile` view. A temp file is shown as dropped if its tablespace is dropped.

Column	Data Type	Description
DB_KEY	NUMBER	The primary key for the target database. Use this column to join with almost any other catalog view.
DBINC_KEY	NUMBER	The primary key for the incarnation of the target database. Use this column to join with <code>RC_DATABASE_INCARNATION</code> .
DB_NAME	VARCHAR2 (8)	The <code>DB_NAME</code> of the database incarnation to which this record belongs.
CON_ID	NUMBER	The ID of the current container: <ul style="list-style-type: none"> <li>• 0: Rows containing data that pertain to the entire multitenant container database (CDB)</li> <li>• 1: Rows containing data that pertains only to the root</li> <li>• <i>n</i>: Where <i>n</i> is the applicable container ID for the rows containing data</li> </ul>
PDB_NAME	VARCHAR2 (30)	The name of the pluggable database (PDB) in the recovery catalog.
PDB_KEY	NUMBER	The primary key for the PDB in the recovery catalog.
TS#	NUMBER	The tablespace ID in the target database. The <code>TS#</code> may exist multiple times in the same incarnation if the tablespace is dropped and re-created.
TABLESPACE_NAME	VARCHAR2 (30)	The tablespace name. The name may exist multiple times in the same incarnation if the tablespace is dropped and re-created.
FILE#	NUMBER	The absolute file number of the temp file. The same temp file number may exist in the same incarnation of the temp file is dropped and re-created.
CREATION_CHANGE#	NUMBER	The SCN when the temp file is created.

Column	Data Type	Description
CREATION_TIME	DATE	The time when the temp file is created.
DROP_CHANGE#	NUMBER	The SCN recorded when the temp file was dropped. If a new temp file with the same FILE# is discovered, then the DROP_CHANGE# is set to CREATION_CHANGE# for the temp file; otherwise, the value is set to RC_CHECKPOINT.CKP_SCN.
DROP_TIME	DATE	The time when the temp file was dropped. If a new temp file with the same FILE# is discovered, then the DROP_TIME is set to CREATION_TIME for the temp file; otherwise the value is RC_CHECKPOINT.CKP_TIME.
BYTES	NUMBER	The size of the temp file in bytes.
BLOCKS	NUMBER	Size of the file in blocks.
BLOCK_SIZE	NUMBER	The block size of the temp file in bytes.
NAME	VARCHAR2 (1024)	The temp file name.
RFILE#	NUMBER	The relative file number of this temp file within the tablespace.
AUTOEXTEND	VARCHAR2 (3)	ON if the temp file is autoextensible. Otherwise OFF.
MAXSIZE	NUMBER	Maximum file size in blocks to which the file can be extended. Valid only when AUTOEXTEND is ON. Always 0 when AUTOEXTEND is OFF.
NEXTSIZE	NUMBER	Amount of incremental size for file extensible in blocks. Valid only when AUTOEXTEND is ON. Always 0 when AUTOEXTEND is OFF.
BIGFILE	VARCHAR2 (3)	YES if the tablespace is a bigfile tablespace; otherwise, NO.
SITE_KEY	NUMBER	Primary key of the Data Guard database associated with this file. Each database in a Data Guard environment has a unique SITE_KEY value. You can use SITE_KEY in a join with the RC_SITE view to obtain the DB_UNIQUE_NAME of the database.
TABLESPACE_CREATION_CHANGE#	NUMBER	SCN at which this tablespace was created.
TABLESPACE_CREATION_TIME	DATE	Timestamp at which this tablespace was created.
TABLESPACE_DROP_CHANGE#	NUMBER	SCN at which this tablespace was dropped.
TABLESPACE_DROP_TIME	DATE	Timestamp at which the tablespace was dropped.
DB_UNIQUE_NAME	VARCHAR2 (512)	The DB_UNIQUE_NAME of the database incarnation to which this record belongs. All databases in a Data Guard environment share the same DBID but different DB_UNIQUE_NAME values. The value in this column is null when the database name is not known for a specific file. For example, rows for databases managed by versions of RMAN before Oracle Database 11g are null.

## 5.61 RC\_UNUSABLE\_BACKUPFILE\_DETAILS

This view lists all backup files (backup pieces, proxy copies or image copies) that are marked UNAVAILABLE or EXPIRED.

You can select a row and, using `BTYPE_KEY` or `FILETYPE_KEY`, change the status of a backup set or specific file to `AVAILABLE`. This view is primarily intended to be used internally by Enterprise Manager.

Column	Data Type	Description
DB_NAME	VARCHAR2 (8)	The <code>DB_NAME</code> of the database incarnation to which this record belongs.
DB_KEY	NUMBER	The primary key for this database in the recovery catalog. Use this column to join with almost any other catalog view.
SESSION_KEY	NUMBER	Session identifier. Use in joins with <code>RC_RMAN_OUTPUT</code> and <code>RC_RMAN_BACKUP_JOB_DETAILS</code> .
RSR_KEY	NUMBER	Unique key for the row in <code>RC_RMAN_STATUS</code> corresponding to the job that created this file.
BTYPE	CHAR (9)	The backup type container, which can be <code>BACKUPSET</code> , <code>IMAGECOPY</code> , or <code>PROXYCOPY</code> .
BTYPE_KEY	NUMBER	Unique identifier for the backup type. It is <code>BS_KEY/COPY_KEY</code> .
ID1	NUMBER	For backups taken as backup sets, this column contains <code>SET_STAMP</code> . For proxy copy or image copy backups, this column contains the <code>RECID</code> from the control file.
ID2	NUMBER	For backups taken as backup sets, <code>ID2</code> contains <code>SET_COUNT</code> . For image copy and proxy copy backups <code>ID2</code> contains <code>STAMP</code> .
FILETYPE	VARCHAR2 (15)	The type of this backup file. Possible values are <code>BACKUPPIECE</code> , <code>COPY</code> , or <code>PROXYCOPY</code> .
FILETYPE_KEY	NUMBER	Backup piece key if the file is a backup piece, otherwise <code>COPY_KEY</code> . You can use this key to directly change the status of the file to available.
STATUS	VARCHAR2 (1)	Can be either <code>U</code> (for unavailable backups) or <code>X</code> (for expired backups).
FILESIZE	NUMBER	Size in bytes of the unusable backup file.
DEVICE_TYPE	VARCHAR2 (255)	Device type storing this unusable backup file. Possible values are <code>DISK</code> and <code>SBT_TAPE</code> .
FILENAME	VARCHAR2 (1024)	File name.
MEDIA	VARCHAR2 (80)	A comment that contains further information about the media manager that created this backup.
MEDIA_POOL	NUMBER	The number of the media pool in which the backup is stored.

# A

## RMAN Reserved Words

RMAN reserved words cannot be used as nonquoted identifiers.

### A.1 List of RMAN Reserved Words

This section lists the RMAN reserved words.

```
,  
#  
(  
)  
\  
{  
}  
<<<  
>>>  
;  
&  
-  
,  
=  
^  
@  
.  
:  
ABORT  
ACCESSIBLE  
ACTIVE  
ADVISEID  
ADVISE  
AES128  
AES192  
AES256  
AFFINITY  
AFTER  
ALGORITHM  
ALLOCATE  
ALLOW  
ALL  
ALTER  
ANALYZE  
AND  
APPEND  
APPLIED
```



ARCHIVELOG  
AREA  
AS  
ATALL  
AT  
AUDIT  
AUTOBACKUP  
AUTOLOCATE  
AUXILIARY  
AUXNAME  
AVAILABILITY  
AVAILABLE  
BACKED  
BACKUPPIECE  
BACKUPSET  
BACKUPS  
BACKUP  
BEFORE  
BEGIN  
BETWEEN  
BLOCKRECOVER  
BLOCKS  
BLOCK  
BY  
CALL  
CANCEL  
CATALOG  
CATALOG\_RESTRICTED  
CHANGE  
CHANGED  
CHANNEL  
CHNAME  
CHECKSYNTAX  
CHECK  
CLEAR  
CLONCENAME  
CLONE  
CLONE\_CF  
CLOSED  
CMDFILE  
COMMAND  
COMMENT  
COMMIT  
COMPATIBLE  
COMPLETED  
COMPRESSED  
COMPRESSION  
CONFIGURE  
CONNECT

CONSISTENT  
CONSTRAINT  
CONTROLFILECOPY  
CONTROLFILE  
CONVERT  
COPIES  
COPY  
CORRUPTION  
CREATE  
CRITICAL  
CROSSCHECK  
CUMULATIVE  
CURRENT  
DATABASE  
DATAFILECOPY  
DATAFILES  
DATAFILE  
DATAPUMP  
DAYS  
DBID  
DB\_FILE\_NAME\_CONVERT  
DB\_NAME  
DB\_RECOVERY\_FILE\_DEST  
DB\_UNIQUE\_NAME  
DBA  
DEBUG  
DECLARE  
DECRYPTED  
DECRYPTION  
DEFAULT  
DEFINE  
DELETE  
DELETION  
DESCRIBE  
DESC  
DESTINATION  
DETAIL  
DEVICE  
DIRECTORY  
DISKRATIO  
DISK  
DISPLAY  
DORECOVER  
DROP  
DUMP  
DUPLEX  
DUPLICATE  
DURATION  
ECHO

ENCRYPTED  
ENCRYPTION  
END-OF-FILE  
EVENT  
EXCLUDE  
EXECUTE  
EXIT  
EXPIRED  
EXPORT  
FAILOVER  
FAILURE  
FAIL  
FALSE  
FARSYNC  
FILESPERSET  
FILES  
FILE  
FILE\_NAME\_CONVERT  
FINAL  
FLASHBACK  
FORCE  
FOREIGN  
FOREVER  
FORMAT  
FOR  
FROM  
FULL  
G  
GET  
GLOBAL  
GRANT  
GROUP  
GUARANTEE  
GUID  
HEADER  
HIGH  
HOST  
IDENTIFIED  
IDENTIFIER  
ID  
IDR  
IMMEDIATE  
IMPORT  
INACCESSIBLE  
INCARNATION  
INCLUDING  
INCLUDE  
INCONSISTENT  
INCREMENTAL

INPUT  
INSERT  
INSTANCE  
INSTANT  
INTO  
IO  
JOB  
KBYTES  
KEEP  
KRB  
KRMTEST  
K  
LEVEL  
LIBPARM  
LIBRARY  
LIKE  
LIMIT  
LINK  
LIST  
LOAD  
LOCATION  
LOCK  
LOGFILE  
LOGICAL  
LOGSCN  
LOGSEQ  
LOGS  
LOG  
LONG  
LOW  
M  
MACHINE  
MAINTENANCE  
MASK  
MAXCORRUPT  
MAXDAYS  
MAXOPENFILES  
MAXPIECESIZE  
MAXSEQ  
MAXSETSIZE  
MAXSIZE  
MERGE  
**MESSAGE**  
METHOD  
MINIMIZE  
MISC  
MOUNT  
MSGLOG  
MSGNO

NAMES  
NAME  
NEED  
NEWLINE  
NEW-NAME  
NEW  
NOAUDIT  
NOBACKUP  
NOCATALOG  
NOCATFOV  
NOCFAU  
NOCHECKSUM  
NOCHECK  
NODEVALS  
NODUPLICATES  
NOEXCLUDE  
NOFILENAMECHECK  
NOFILEUPDATE  
NOIMPORT  
NOKEEP  
NOLOGS  
NOMOUNT  
NONE  
NONLOGGED  
NONSPARSE  
NOOPEN  
NOPARALLEL  
NOPROMPT  
NOREDO  
NOREMOVE  
NORESUME  
NORMAL  
NOTABLEIMPORT  
NOTACCESSIBLE  
NOTTS  
NOT  
NO  
NULL  
NUMWIDTH  
NUMBER  
OBSOLETE  
OFFLINE  
OFF  
OF  
ONLY  
ON  
OPEN  
OPTIMIZATION  
OPTIMIZE

OPTION  
ORPHAN  
OR  
OUTPUT  
PACKAGES  
PARALLELISM  
PARALLELMEDIASTORE  
PARALLEL  
PARAMETER\_VALUE\_CONVERT  
PARAMETER  
PARMS  
PARTIAL  
PASSPHRASE  
PASSWORD  
PFILE  
PIPE  
PLAN  
PLATFORM  
PLSQL  
PLUGGABLE  
PLUS  
POINT  
POLICY  
POOL  
PREVIEW  
PREPLUGIN  
PRIMARY  
PRINT  
PRIORITY  
PRIVILEGES  
PROXY  
PURGE  
PUT  
QUIT  
RATE  
RASCHEMAVERSION  
RCVCAT  
RCVMAN  
READONLY  
READRATE  
RECALL  
RECOVERABLE  
RECOVERY  
RECOVER  
REDO  
REDUNDANCY  
REGISTER  
RELEASE  
RELOAD

REMAP  
REMOVE  
RENAME  
RENORMALIZE  
REPAIRID  
REPAIR  
REPLACE  
REPLICATE  
REPORT  
RESETLOGS  
RESET  
RESTORE  
RESTART  
RESTRICTED  
RETENTION  
RESYNC  
REUSE  
REVOKE  
RMAN  
ROLE  
ROLLBACK  
ROOT  
RPCTEST  
RPC  
RUN  
SAVEPOINT  
SAVE  
SCHEMA  
SCN  
SCRIPT  
SECONDS  
SECTION  
SELECT  
SEND  
SEQUENCE  
SERVER  
SERVICE  
SETLIMIT  
SETSIZE  
SET  
SHIPPED  
SHOW  
SHUTDOWN  
SINCE  
SIZE  
SKIP  
SLAXDEBUG  
SLEEP  
SNAPSHOT

SPARSE  
SPFILE  
SPOOL  
SQL  
STANDBY  
STARTUP  
START  
STATISTICS  
STEP  
SUMMARY  
SWITCH  
TABLESPACES  
TABLESPACE  
TABLE  
TAG  
TARGETFILE  
TARGET  
TDES168  
TEMPFILE  
TEST  
THREAD  
TIMEOUT  
TIMES  
TIME  
TO  
TRACE  
TRACKING  
TRANSACTIONAL  
TRANSACTION  
TRANSPORT  
**TRUE**  
TRUNCATE  
TSPITR  
TYPE  
UNAVAILABLE  
UNCATALOG  
UNDO  
UNKNOWN  
UNLIMITED  
UNNECESSARY  
UNPLUG  
UNRECOVERABLE  
UNREGISTER  
UNTIL  
UP  
UPDATE  
UPGRADE  
USING  
VALIDATE



VERBOSE  
VIRTUAL  
WALLET  
WINDOW  
WITH

# B

## RMAN Command Examples Quick Reference

This appendix provides a few examples for commonly used RMAN commands.

**Table B-1 Commonly Used RMAN Command Examples**

Operation	Command Example
<b>CONNECT</b> <i>Starting and connecting to RMAN</i>	<pre>RMAN&gt; TARGET "sbu@prod AS SYSBACKUP" AUXILIARY "sbu@dupdb AS SYSBACKUP";  RMAN&gt; CONNECT TARGET "sbu@inst1 AS SYSBACKUP";  RMAN&gt; CONNECT TARGET "sbu@prod AS SYSDBA";  rman target / rman AUXILIARY SYS/PWD@AUX_STRING  RMAN TARGET "sbu@prod AS SYSDBA" AUXILIARY "sbu@dupdb AS SYSDBA";</pre>

Table B-1 (Cont.) Commonly Used RMAN Command Examples

Operation	Command Example
<b>ALLOCATE CHANNEL</b>	<pre> RMAN&gt; ALLOCATE CHANNEL c1 DEVICE TYPE 'SBT_TAPE';  RMAN&gt; ALLOCATE CHANNEL c1 DEVICE TYPE DISK FORMAT 'c:\oraclebkp\db_u%';  RMAN&gt; ALLOCATE CHANNEL t1 DEVICE TYPE DISK CONNECT 'sys/pwd@bkp1';  RMAN&gt; ALLOCATE CHANNEL c1 DEVICE TYPE 'SBT_TAPE' PARMS 'ENV=(OB_MEDIA_FAMILY=wholedb_mf)';  RMAN&gt; ALLOCATE CHANNEL t1 DEVICE TYPE SBT_TAPE PARMS 'ENV=(OB_DEVICE_1=tape1, OB_DEVICE_2=tape3)';  RMAN&gt; ALLOCATE CHANNEL t1 TYPE 'SBT_TAPE' PARMS='SBT_LIBRARY=/usr/opensv/netbackup/bin/ libobk.so.1';  RMAN&gt; ALLOCATE CHANNEL t1 TYPE 'SBT_TAPE' SEND "NB_ORA_CLIENT=CLIENT_MACHINE_NAME";  RMAN&gt; ALLOCATE CHANNEL 'dev1' TYPE 'SBT_TAPE' PARMS 'ENV=OB2BARTYPE=ORACLE8, OB2APPNAME=ORCL, OB2BARLIST=MACHINENAME_ORCL_ARCHLOGS)';  RMAN&gt; ALLOCATE CHANNEL y1 TYPE DISK RATE 70M;  RMAN&gt; ALLOCATE AUXILIARY CHANNEL ac1 TYPE DISK;  RMAN&gt; ALLOCATE AUXILIARY CHANNEL ac2 DEVICE TYPE SBT;  <i>To simulate SBT_TAPE with Oracle internal API</i>  The internal API accepts sbt calls just as any media library. The output is redirected to BACKUP_DIR.  RMAN&gt; ALLOCATE CHANNEL t1 DEVICE TYPE sbt PARMS='sbt_library=oracle.disksbt, ENV=(backup_dir=/tmp)'; </pre>

**Table B-1 (Cont.) Commonly Used RMAN Command Examples**

Operation	Command Example
ALLOCATE CHANNEL FOR MAINTENANCE	<pre>RMAN&gt; ALLOCATE CHANNEL FOR MAINTENANCE DEVICE TYPE DISK;</pre>
	<pre>RMAN&gt; ALLOCATE CHANNEL FOR MAINTENANCE DEVICE TYPE DISK FORMAT "/disk2/%U";</pre>
	<p>See: <a href="#">formatSpec</a> for RMAN substitution variables.</p>
	<pre>RMAN&gt; ALLOCATE CHANNEL FOR MAINTENANCE DEVICE TYPE DISK CONNECT '@test1';</pre>
	<pre>RMAN&gt; ALLOCATE CHANNEL FOR MAINTENANCE DEVICE TYPE sbt;</pre>
	<pre>RMAN&gt; ALLOCATE CHANNEL FOR MAINTENANCE DEVICE TYPE sbt PARMS 'SBT_LIBRARY=/usr/local/oracle/ backup/lib/libobk.so, ENV=(OB_DEVICE_1=tape2)';</pre>
	<pre>RMAN&gt; ALLOCATE CHANNEL FOR MAINTENANCE DEVICE TYPE 'SBT_TAPE' PARMS='SBT_LIBRARY=ORACLE.DISKSBT, ENV=(BACKUP_DIR=/TMP)';</pre>

**Table B-1 (Cont.) Commonly Used RMAN Command Examples**

Operation	Command Example
BACKUP	RMAN> BACKUP DATABASE;
	RMAN> BACKUP DATABASE TAG='test backup';
	RMAN> BACKUP TAG 'Weekly_Full_DB_Backup' DATABASE MAXSETSIZE 10M;
	RMAN> BACKUP MAXSETSIZE 500M DATABASE PLUS ARCHIVELOG;
	RMAN> BACKUP DURATION 00:60 DATABASE;
	RMAN> BACKUP DURATION 00:30 MINIMIZE TIME DATABASE;
	RMAN> BACKUP DURATION 00:45 MINIMIZE LOAD DATABASE;
	RMAN> BACKUP DATABASE PLUS ARCHIVELOG;
	RMAN> BACKUP DATABASE KEEP FOREVER;
	RMAN> BACKUP DATABASE KEEP UNTIL TIME='SYSDATE+30';
	RMAN> BACKUP DATABASE UNTIL 'SYSDATE+365' NOLOGS;
	RMAN> BACKUP DATABASE NOEXCLUDE;
	RMAN> BACKUP DATABASE NOEXCLUDE KEEP FOREVER TAG='abc';
	RMAN> BACKUP DATABASE SKIP READONLY;
	RMAN> BACKUP DATABASE SKIP OFFLINE;
	RMAN> BACKUP DATABASE SKIP INACCESSIBLE;
	RMAN> BACKUP DATABASE SKIP READONLY SKIP OFFLINE SKIP INACCESSIBLE;

**Table B-1 (Cont.) Commonly Used RMAN Command Examples**

Operation	Command Example
	<p><i>To back up a read-only database regardless of optimization</i></p> <pre>RMAN&gt; BACKUP DATABASE FORCE;</pre> <pre>RMAN&gt; BACKUP DATABASE NOT BACKED UP;</pre> <pre>RMAN&gt; BACKUP DATABASE NOT BACKED UP SINCE TIME='SYSDATE-3';</pre> <pre>RMAN&gt; BACKUP NOT BACKED UP SINCE TIME 'SYSDATE-10' MAXSETSIZE 500M DATABASE PLUS ARCHIVELOG;</pre> <pre>RMAN&gt; BACKUP DATABASE COPIES=2;</pre> <pre>RMAN&gt; BACKUP DATABASE FORMAT '/DISK1/BACKUPS/ DB_%U.BCK' TAG quarterly KEEP UNTIL TIME 'SYSDATE+365' RESTORE POINT Q1FY12;</pre> <p>See: <a href="#">formatSpec</a> for RMAN substitution variables.</p> <pre>RMAN&gt; BACKUP DEVICE TYPE DISK DATABASE;</pre> <pre>RMAN&gt; BACKUP DEVICE TYPE SBT DATABASE PLUS ARCHIVELOG;</pre> <pre>RMAN&gt; BACKUP DEVICE TYPE SBT DATAFILECOPY FROM TAG 'Latest' FORMAT 'DF%F_%D';</pre> <p>See <a href="#">formatSpec</a> for RMAN substitution variables.</p> <pre>RMAN&gt; BACKUP DEVICE TYPE SBT ARCHIVELOG LIKE '/ disk%arc%' DELETE ALL INPUT;</pre> <pre>RMAN&gt; BACKUP DEVICE TYPE SBT BACKUPSET COMPLETED BEFORE 'SYSDATE-14' DELETE INPUT;</pre> <pre>RMAN&gt; BACKUP TABLESPACE TEST;</pre> <pre>RMAN&gt; BACKUP TABLESPACE SYSTEM, USERS, TOOLS;</pre>

**Table B-1 (Cont.) Commonly Used RMAN Command Examples**

Operation	Command Example
	RMAN> BACKUP TABLESPACE 4;
	RMAN> BACKUP TABLESPACE USERS PLUS ARCHIVELOG;
	RMAN> BACKUP TABLESPACE USERS INCLUDE CURRENT CONTROLFILE;
	RMAN> BACKUP TABLESPACE USERS INCLUDE CURRENT CONTROLFILE PLUS ARCHIVELOG;
	RMAN> BACKUP TABLESPACE USERS SECTION SIZE 100M;
	RMAN> BACKUP SECTION SIZE 250M TABLESPACE USERS;
	RMAN> BACKUP DATAFILE 9;
	RMAN> BACKUP DATAFILE '/U01/DATA/...';
	RMAN> BACKUP DATAFILE 1 PLUS ARCHIVELOG;
	RMAN> BACKUP KEEP FOREVER FORMAT '?/DBS/ %U_LONGTERM.CPY' TAG 'Longterm_bck' DATAFILE 1 DATAFILE 2;
	<b>See <a href="#">formatSpec</a> for RMAN substitution variables.</b>
	RMAN> BACKUP SECTION SIZE 500M DATAFILE 6;
	RMAN> BACKUP ARCHIVELOG ALL;
	RMAN> BACKUP ARCHIVELOG ALL DELETE INPUT;
	RMAN> BACKUP ARCHIVELOG LIKE '/arch%' DELETE ALL INPUT;
	RMAN> BACKUP ARCHIVELOG FROM TIME 'SYSDATE-3';
	RMAN> BACKUP ARCHIVELOG FROM SEQUENCE 100;

**Table B-1 (Cont.) Commonly Used RMAN Command Examples**

Operation	Command Example
	RMAN> BACKUP ARCHIVELOG FROM SEQUENCE 999 DELETE INPUT;
	RMAN> BACKUP ARCHIVELOG FROM SEQUENCE 123 DELETE ALL INPUT;
	RMAN> BACKUP ARCHIVELOG FROM SEQUENCE 21531 UNTIL SEQUENCE 21590 FORMAT '/tmp/archive_backup.bkp';
	RMAN> BACKUP ARCHIVELOG ALL FROM SEQUENCE 1200 DELETE ALL INPUT;
	RMAN> BACKUP CHECK LOGICAL DATABASE;
	RMAN> BACKUP ARCHIVELOG NOT BACKED UP 2 TIMES;
	RMAN> BACKUP ARCHIVELOG COMPLETION TIME BETWEEN 'SYSDATE-28' AND 'SYSDATE-7';
	RMAN> BACKUP FORMAT='AL_%D/%T/%S/%P' ARCHIVELOG LIKE '%arc_dest%';
	See <a href="#">formatSpec</a> for RMAN substitution variables.
	RMAN> BACKUP CURRENT CONTROLFILE TO '/backup/cntrlfile.copy';
	RMAN> BACKUP CONTROLFILE COPY '/u10/backup/control.bkp';
	RMAN> BACKUP SPFILE;
	RMAN> BACKUP DEVICE TYPE SBT SPFILE ARCHIVELOG ALL;
	RMAN> BACKUP DEVICE TYPE SBT DATAFILECOPY ALL NODUPLICATES;
	RMAN> BACKUP RECOVERY FILES;



**Table B-1 (Cont.) Commonly Used RMAN Command Examples**

Operation	Command Example
	<pre>RMAN&gt; BACKUP PLUGGABLE DATABASE pdb1,pdb2;</pre> <p><i>Backup - Validate Target</i></p> <pre>RMAN&gt; BACKUP VALIDATE CHECK LOGICAL DATABASE;</pre> <pre>RMAN&gt; BACKUP VALIDATE DATABASE;</pre> <pre>RMAN&gt; BACKUP VALIDATE DATABASE ARCHIVELOG ALL;</pre> <pre>RMAN&gt; BACKUP CHECK LOGICAL VALIDATE TABLESPACE DATA;</pre> <p><i>For bigfile tablespace data files</i></p> <pre>RMAN&gt; BACKUP CHECK LOGICAL VALIDATE TABLESPACE DATA SECTION SIZE 64G;</pre>
BLOCK LEVEL <b>RECOVER</b>	<pre>RMAN&gt; RECOVER CORRUPTION LIST;</pre> <pre>RMAN&gt; RECOVER DATAFILE 8 block 22;</pre> <pre>RMAN&gt; RECOVER DATAFILE 7 block 233,235 DATAFILE 4 block 101;</pre> <pre>RMAN&gt; RECOVER DATAFILE 2 block 12,13 DATAFILE 3 block 5,98,99 DATAFILE 4 block 19;</pre> <pre>RMAN&gt; RECOVER DATAFILE 3 block 2,4,5 TABLESPACE sales DBA 4194405,4194412 FROM DATAFILECOPY;</pre> <pre>RMAN&gt; RECOVER TABLESPACE DATA DBA 4194404,4194405 FROM TAG "weekly";</pre> <pre>RMAN&gt; RECOVER TABLESPACE DATA DBA 94404 RESTORE UNTIL TIME 'SYSDATE-2';</pre> <pre>RMAN&gt; RECOVER DATAFILE 40 block 1089408 NOFILEUPDATE SAVE all blocks;</pre>

**Table B-1 (Cont.) Commonly Used RMAN Command Examples**

Operation	Command Example
CATALOG	<pre>RMAN&gt; CATALOG DATAFILECOPY '/disk2/backup/ users01.bak';  RMAN&gt; CATALOG DATAFILECOPY '/disk2/backup/ users01.bak' LEVEL 0;  RMAN&gt; CATALOG CONTROLFILECOPY '/disk3/backup/ cf_copy.bkp';  RMAN&gt; CATALOG ARCHIVELOG '&lt;arch location&gt;';  RMAN&gt; CATALOG BACKUPPIECE '/disk1/ c-874220581-20131128-01';  RMAN&gt; CATALOG START WITH '/fs2/arch';  RMAN&gt; CATALOG START WITH '/disk2/archlog' noprompt;  RMAN&gt; CATALOG START WITH '+flash';  RMAN&gt; CATALOG RECOVERY AREA;</pre>

**Table B-1 (Cont.) Commonly Used RMAN Command Examples**

Operation	Command Example
CHANGE	RMAN> CHANGE BACKUPSET 333 KEEP FOREVER;
	RMAN> CHANGE BACKUPSET 431 KEEP FOREVER NOLOGS;
	RMAN> CHANGE BACKUPSET 100 UNAVAILABLE;
	RMAN> CHANGE BACKUPSET 123 NOKEEP;
	RMAN> CHANGE BACKUPSET 121,122,127,203,300 UNCATALOG;
	RMAN> CHANGE BACKUP OF DATABASE TAG='abc' UNAVAILABLE;
	RMAN> CHANGE BACKUP OF DATABASE DEVICE TYPE DISK UNAVAILABLE;
	RMAN> CHANGE COPY OF DATABASE CONTROLFILE NOKEEP;
	RMAN> CHANGE BACKUP OF SPFILE COMPLETED BEFORE 'SYSDATE-3' UNAVAILABLE;
	RMAN> CHANGE BACKUP TAG 'consistent_db_bkup' KEEP FOREVER;
	RMAN> CHANGE BACKUP TAG 'consistent_db_bkup' DATABASE KEEP FOREVER;
	RMAN> CHANGE BACKUP TAG 'consistent_db_bkup' KEEP FOREVER NOLOGS;
	RMAN> CHANGE BACKUP TAG 'consistent_db_bkup' NOKEEP;
	RMAN> CHANGE ARCHIVELOG ALL UNCATALOG;
	RMAN> CHANGE CONTROLFILECOPY '/tmp/cf.cpy' UNCATALOG;
	RMAN> CHANGE FAILURE 5 PRIORITY LOW;

**Table B-1 (Cont.) Commonly Used RMAN Command Examples**

Operation	Command Example
	RMAN> CHANGE BACKUP FOR DB_UNIQUE_NAME standby1 RESET DB_UNIQUE_NAME;
	RMAN> CHANGE BACKUP FOR DB_UNIQUE_NAME standby3 RESET DB_UNIQUE_NAME TO standby2;
	RMAN> CHANGE DB_UNIQUE_NAME FROM rdbms4 TO rdbms_dev;

**Table B-1 (Cont.) Commonly Used RMAN Command Examples**

Operation	Command Example
CONVERT	<pre> RMAN&gt; CONVERT DATABASE ON DESTINATION PLATFORM CONVERT SCRIPT '/tmp/convertdb/convertscript.rman' TRANSPORT SCRIPT '/tmp/convertdb/ transportscript.sql' NEW DATABASE 'prodwin' FORMAT '/tmp/convertdb/%U';  RMAN&gt; CONVERT DATABASE ON DESTINATION PLATFORM CONVERT SCRIPT '/tmp/convertdb/ convertscript.rman' TRANSPORT SCRIPT '/tmp/convertdb/ transportscript.sql' NEW DATABASE 'prodwin' FORMAT '/tmp/convertdb/%U';  RMAN&gt; CONVERT DATABASE ON DESTINATION PLATFORM CONVERT SCRIPT '/tmp/convert_newdb.rman' TRANSPORT SCRIPT '/tmp/transport_newdb.sql' NEW DATABASE 'prodaix' DB_FILE_NAME_CONVERT '/u01/oradata/ datafile','+DATA';  RMAN&gt; CONVERT TABLESPACE tbs_2 FORMAT '/tmp/ tbs_2_%U.df';  RMAN&gt; CONVERT TABLESPACE finance, hr TO PLATFORM 'Solaris[tm] OE (32-bit)';  RMAN&gt; CONVERT TABLESPACE finance, hr TO PLATFORM 'Solaris[tm] OE (32-bit)' FORMAT '/tmp/transport_to_solaris/%U';  RMAN&gt; CONVERT DATAFILE '/disk1/oracle/dbs/ tbs_f1.df', '/disk1/oracle/dbs/ax1.f' FORMAT '+DATAFILE';  RMAN&gt; CONVERT DATAFILE '/u01/oradata/datafile/ system.dbf' FROM PLATFORM 'linux x86 64-bit' FORMAT '+DATA/system.dbf';  RMAN&gt; CONVERT DATAFILE </pre>

**Table B-1 (Cont.) Commonly Used RMAN Command Examples**

Operation	Command Example
	<pre> '/tmp/from_solaris/fin/fin01.dbf','/tmp/ from_solaris/fin/fin02.dbf','/tmp/ from_solaris/hr/hr01.dbf', '/tmp/from_solaris/hr/hr02.dbf' DB_FILE_NAME_CONVERT '/tmp/from_solaris/fin','/disk2/orahome/dbs/ fin', '/tmp/from_solaris/hr','/disk2/orahome/dbs/hr' FROM PLATFORM 'Solaris[tm] OE (64-bit)'; </pre>
	<pre> RMAN&gt; CONVERT DATAFILE '/tmp/psmn.dbf' TO PLATFORM='solaris operating system (x86-64)' FROM PLATFORM='Solaris[tm] OE (64-bit)' FORMAT '/tmp/test/%n.dbf' DB_FILE_NAME_CONVERT='/ui/prod/oracle/oradata/ searchp/data /', '/tmp/test'; </pre>
	<p>See: <a href="#">formatSpec</a> for RMAN substitution variables.</p>

**Table B-1 (Cont.) Commonly Used RMAN Command Examples**

Operation	Command Example
DELETE	<pre>RMAN&gt; DELETE ARCHIVELOG ALL COMPLETED BEFORE 'SYSDATE-2';</pre>
	<pre>RMAN&gt; DELETE ARCHIVELOG ALL BACKED UP 2 TIMES TO DEVICE TYPE SBT;</pre>
	<pre>RMAN&gt; DELETE ARCHIVELOG ALL LIKE '%755153075%';</pre>
	<pre>RMAN&gt; DELETE ARCHIVELOG UNTIL SEQUENCE=79228;</pre>
	<pre>RMAN&gt; DELETE FORCE ARCHIVELOG ALL COMPLETED BEFORE 'SYSDATE-1.5';</pre>
	<pre>RMAN&gt; DELETE FORCE ARCHIVELOG UNTIL SEQUENCE=16364;</pre>
	<pre>RMAN&gt; DELETE NOPROMPT ARCHIVELOG UNTIL SEQUENCE = 7300;</pre>
	<pre>RMAN&gt; DELETE EXPIRED ARCHIVELOG ALL;</pre>
	<pre>RMAN&gt; DELETE NOPROMPT EXPIRED ARCHIVELOG ALL;</pre>
	<pre>RMAN&gt; DELETE BACKUPSET 101, 102, 103;</pre>
	<pre>RMAN&gt; DELETE NOPROMPT BACKUPSET TAG 'weekly_bkup';</pre>
	<pre>RMAN&gt; DELETE FORCE NOPROMPT BACKUPSET TAG 'weekly_bkup';</pre>
	<pre>RMAN&gt; DELETE DATAFILECOPY "+DG_DATA/DB/DATAFILE/ SYSTEM.259.699468079";</pre>
	<pre>RMAN&gt; DELETE CONTROLFILECOPY '/TMP/ CNTRLFILE.COPY';</pre>
	<pre>RMAN&gt; DELETE BACKUP DEVICE TYPE SBT;</pre>
	<pre>RMAN&gt; DELETE BACKUP DEVICE TYPE DISK;</pre>

**Table B-1 (Cont.) Commonly Used RMAN Command Examples**

Operation	Command Example
	RMAN> DELETE COPY;
	RMAN> DELETE EXPIRED COPY;
	RMAN> DELETE COPY TAG 'latest';



Table B-1 (Cont.) Commonly Used RMAN Command Examples

Operation	Command Example
DUPLICATE	<p data-bbox="683 352 1453 512"><i>Connect to an auxiliary instance and start RMAN duplicate. The duplicate operation will restore the root and the pluggable database <code>pdb3</code>, and skip two tablespaces from <code>pdb3</code>. When the duplicate operation is complete, a clone CDB with root and <code>pdb3</code> will exist, but without <code>tsb_arch</code> and data.</i></p> <pre data-bbox="683 541 1453 835">CONNECT AUXILIARY / SET ECHO ON RUN { DUPLICATE DATABASE TO M12123 PLUGGABLE DATABASE pdb3, root SKIP TABLESPACE pdb3:tsb_arch, pdb3:data BACKUP LOCATION '/ade/b/2963778449/oracle/work/ M1212'; }</pre> <p data-bbox="683 865 1453 1024"><i>The following command will execute duplicate of the CDB from tape backups while skipping a tablespace in the pluggable database <code>PDB1</code>. Only a subset of the PDB is recovered. With the <code>NODROP TABLESPACE</code> clause, the <code>PDB1:DATA1</code> will exist and the file will show as <code>MISSING</code>.</i></p> <pre data-bbox="683 1054 1453 1904">RUN { ALLOCATE AUXILIARY CHANNEL aux1 DEVICE TYPE 'SBT_TAPE' PARMS 'SBT_LIBRARY=oracle.disksbt, ENV=(BACKUP_DIR=/ade/b/1990733200/oracle/work/ clone/tape)'; ALLOCATE AUXILIARY CHANNEL aux2 DEVICE TYPE 'SBT_TAPE' PARMS 'SBT_LIBRARY=oracle.disksbt,ENV=(BACKUP_DIR=/ade /b/1990733200/oracle/work/clone/tape)'; SET UNTIL TIME "TO_DATE ('2022-08-04 14:10:00', 'YYYY-MM-DD HH24:MI:SS')"; SET DBID 2108978997; SET NEWNAME FOR DATABASE TO '/ade/b/1990733200/ oracle/work/clone/data/M195/%b'; DUPLICATE DATABASE M19 to M195 PFILE='/ade/b/ 1990733200/rdbms/dbs/initM195.ora' LOGFILE GROUP 1 ('/ade/b/1990733200/oracle/work/clone/data/ M195/orl_group1_log1.f', '/ade/b/1990733200/ oracle/work/clone/data/M195/orl_group1_log2.f') SIZE 25M REUSE, GROUP 2 ('/ade/b/1990733200/oracle/work/clone/ data/M195/orl_group2_log1.f', '/ade/b/1990733200/ oracle/work/clone/data/M195/orl_group2_log2.f') SIZE 25M REUSE PLUGGABLE DATABASE pdb1 SKIP TABLESPACE pdb1:data1</pre>

**Table B-1 (Cont.) Commonly Used RMAN Command Examples**

Operation	Command Example
	<pre>NODROP TABLESPACE NOOPEN; } EXIT</pre>
	<p>See <a href="#">formatSpec</a> for RMAN substitution variables.</p>
<b>FLASHBACK DATABASE</b>	<pre>RMAN&gt; LIST RESTORE POINT ALL;  RMAN&gt; FLASHBACK DATABASE TO SCN 411010;  RMAN&gt; FLASHBACK DATABASE TO RESTORE POINT 'before_update';  RMAN&gt; FLASHBACK PLUGGABLE DATABASE pdb1 TO RESTORE POINT 'pdb1_grp_before_upgrade' AUXILIARY DESTINATION '/temp/aux_dest';  RMAN&gt; FLASHBACK TABLE scott.emp TO BEFORE DROP;  SQL&gt; FLASHBACK TABLE scott.emp TO BEFORE DROP;</pre>

**Table B-1 (Cont.) Commonly Used RMAN Command Examples**

Operation	Command Example
LIST	RMAN> LIST BACKUP SUMMARY;
	RMAN> LIST BACKUP OF DATABASE;
	RMAN> LIST BACKUP;
	RMAN> LIST BACKUP OF PLUGGABLE DATABASE orcl, pdb1;
	RMAN> LIST COPY OF DATAFILE 2, 3 ,6;
	RMAN> LIST BACKUP OF DATAFILE 4 SUMMARY;
	RMAN> LIST ARCHIVELOG ALL;
	RMAN> LIST BACKUP OF ARCHIVELOG ALL;
	RMAN> LIST COPY OF DATABASE ARCHIVELOG ALL;
	RMAN> LIST INCARNATION;
	RMAN> LIST BACKUP OF CONTROLFILE;
	RMAN> LIST BACKUP OF SPFILE;
	RMAN> LIST BACKUP BY FILE;
	RMAN> LIST BACKUP BY FILE;
	RMAN> LIST BACKUP OF DATAFILE 1;
	RMAN> LIST EXPIRED BACKUP;
	RMAN> LIST EXPIRED BACKUP SUMMARY;
	RMAN> LIST EXPIRED BACKUP OF ARCHIVELOG ALL;
	RMAN> LIST EXPIRED BACKUP OF DATAFILE 10;

**Table B-1 (Cont.) Commonly Used RMAN Command Examples**

Operation	Command Example
	<pre>RMAN&gt; LIST EXPIRED BACKUP OF ARCHIVELOG ALL SUMMARY;</pre>
	<pre>RMAN&gt; LIST FAILURE;</pre>
	<pre>RMAN&gt; LIST FAILURE 641231 DETAIL;</pre>
	<pre>RMAN&gt; LIST BACKUP OF TABLESPACE test SUMMARY;</pre>
	<pre>RMAN&gt; LIST BACKUP OF TABLESPACE test;</pre>
	<pre>RMAN&gt; LIST BACKUP OF ARCHIVELOG FROM SEQUENCE 55;</pre>
	<pre>RMAN&gt; LIST BACKUPSET OF DATAFILE 1;</pre>
	<pre>RMAN&gt; LIST RECOVERABLE BACKUP;</pre>
	<pre>RMAN&gt; LIST CONTROLFILECOPY "/tmp/ cntrlfile.copy";</pre>
	<pre>RMAN&gt; LIST BACKUPSET OF DATAFILE 1;</pre>
	<pre>RMAN&gt; LIST BACKUP TAG 'ORCL_FULL';</pre>
	<pre>RMAN&gt; LIST BACKUPPIECE '&lt;piece_name&gt;';</pre>
	<pre>RMAN&gt; LIST BACKUP RECOVERABLE;</pre>
	<pre>RMAN&gt; LIST BACKUP OF ARCHIVELOG FROM SCN 853145 UNTIL SCN 854039;</pre>
	<pre>RMAN&gt; LIST DATAFILECOPY '/u01/app/oracle/copy/ users01.dbf';</pre>
	<pre>RMAN&gt; LIST COPY OF CONTROLFILE;</pre>
	<pre>RMAN&gt; LIST ARCHIVELOG ALL BACKED UP 1 TIMES TO DISK;</pre>

**Table B-1 (Cont.) Commonly Used RMAN Command Examples**

Operation	Command Example
	<pre> RMAN&gt; LIST BACKUP OF ARCHIVELOG FROM SCN 901427;  RMAN&gt; LIST INCARNATION OF DATABASE orcl;  RMAN&gt; LIST BACKUP OF CONTROLFILE DATABASE ARCHIVELOG ALL; </pre>
MERGED INCREMENTAL BACKUP	<p data-bbox="683 632 1281 659"><i>Recover to merge incremental backup to database copy</i></p> <pre> RUN { RECOVER COPY OF DATABASE WITH TAG 'mib_level_0'; BACKUP INCREMENTAL LEVEL 1 COPIES=1 FOR RECOVER OF COPY WITH TAG 'mib_level_0' DATABASE; }  RUN ( BACKUP INCREMENTAL LEVEL 1 COPIES=1 FOR RECOVER OF COPY WITH TAG 'mib_level_0' DATABASE; RECOVER COPY OF DATABASE WITH TAG 'mib_level_0'; } </pre>

**Table B-1 (Cont.) Commonly Used RMAN Command Examples**

Operation	Command Example
<b>RECOVER</b> Tablespace Point-in-Time Recovery (TSPITR)	<pre> RMAN&gt; RECOVER DATABASE;  RMAN&gt; RECOVER DATABASE NOREDO;  RMAN&gt; RECOVER DATABASE SKIP TABLESPACE foo;  RMAN&gt; RECOVER DATABASE SKIP FOREVER TABLESPACE baddata;  RMAN&gt; RECOVER DATABASE UNTIL SCN 154876;  RMAN&gt; RECOVER TABLESPACE users;  <i>If there is a space constraint to restore archive logs, use MAXSIZE to recover.</i>  RMAN&gt; RECOVER TABLESPACE DATA DELETE ARCHIVELOG MAXSIZE 2M;  RMAN&gt; RECOVER DATABASE DELETE ARCHIVELOG MAXSIZE 1024M;  RMAN&gt; RECOVER DATAFILE 33;  RMAN&gt; RECOVER DATAFILE 3 block 116 DATAFILE 4 block 10;  RMAN&gt; RECOVER DATAFILE 2 block 204 DATAFILE 9 block 109 FROM TAG=sundaynight;  RMAN&gt; RECOVER DATAFILECOPY '/disk1/img.df' UNTIL TIME 'SYSDATE-7';  RMAN&gt; RECOVER COPY OF DATABASE WITH TAG 'merge';  RMAN&gt; RECOVER COPY OF DATABASE WITH TAG 'merge' UNTIL TIME 'SYSDATE - 7';  RMAN&gt; RECOVER CORRUPTION LIST;  <i>Recover standby database from primary service</i>  RMAN&gt; RECOVER DATABASE FROM SERVICE boston </pre>

**Table B-1 (Cont.) Commonly Used RMAN Command Examples**

Operation	Command Example
	<pre>NOREDO USING COMPRESSED BACKUPSET SECTION SIZE 100m;</pre>
	<pre>RMAN&gt; RECOVER DATABASE FROM SERVICE prim SECTION SIZE 120M USING COMPRESSED BACKUPSET;</pre>
	<pre>RMAN&gt; RECOVER DATABASE FROM SERVICE prim SECTION SIZE 120M;</pre>
	<i>Table recovery</i>
	<pre>RMAN&gt; RECOVER TABLE "TEST.EMP" OF PLUGGABLE DATABASE pdb1 UNTIL TIME "TO_DATE('20-JUL-2022 15:00:00','DD- MON-YYYY HH24:MI:SS')"</pre> <p>AUXILIARY DESTINATION='/ade/b/56264301/oracle/work/aux_dest'</p> <p>DATAPUMP DESTINATION='/ade/b/56264301/oracle/work/aux_dest';</p>
	<i>Tablespace Point-in-Time Recovery (TSPITR)</i>
	<pre>RMAN&gt; RUN { SET NEWNAME FOR DATAFILE 'ORACLE_HOME/oradata/trgt/users01.dbf' TO '/newfs/users01.dbf'; ...other SET NEWNAME commands... RECOVER TABLESPACE users, tools UNTIL SEQUENCE 1300 THREAD 1; }</pre>
	<pre>RMAN&gt; RUN { SET NEWNAME FOR DATAFILE '*/oradata/prod/system01.dbf' TO '/disk1/auxdest/system01.dbf'; SET NEWNAME FOR DATAFILE '*/oradata/prod/ sysaux01.dbf' TO '/disk1/auxdest/sysaux01.dbf'; SET NEWNAME FOR DATAFILE '*/oradata/prod/ undotbs01.dbf' TO '/disk1/auxdest/undotbs01.dbf'; RECOVER TABLESPACE users, tools UNTIL SEQUENCE 1300 THREAD 1 AUXILIARY DESTINATION '/disk1/auxdest'; }</pre>

**Table B-1 (Cont.) Commonly Used RMAN Command Examples**

<b>Operation</b>	<b>Command Example</b>
<b>RESTORE</b>	<pre>RMAN&gt; RESTORE DATABASE;</pre>
	<pre>RMAN&gt; RESTORE DATABASE VALIDATE;</pre>
	<pre>RMAN&gt; RESTORE DATABASE PREVIEW;</pre>
	<pre>RMAN&gt; RESTORE DATABASE PREVIEW SUMMARY;</pre>
	<pre>RMAN&gt; RESTORE DATABASE SKIP TABLESPACE temp, history;</pre>
	<pre>RMAN&gt; RESTORE DATABASE UNTIL SCN 154876;</pre>
	<pre>RMAN&gt; RESTORE TABLESPACE users;</pre>
	<pre>RMAN&gt; RESTORE TABLESPACE data1, data2;</pre>
	<pre>RMAN&gt; RESTORE TABLESPACE tbs1 PREVIEW;</pre>
	<pre>RMAN&gt; RESTORE TABLESPACE users VALIDATE;</pre>
	<pre>RMAN&gt; RESTORE DATAFILE 45;</pre>
	<pre>RMAN&gt; RESTORE DATAFILE 23 PREVIEW;</pre>
	<pre>RMAN&gt; RESTORE DATAFILE 12 VALIDATE;</pre>
	<pre>RMAN&gt; RESTORE CONTROLFILE;</pre>
	<pre>RMAN&gt; RESTORE CONTROLFILE FROM AUTOBACKUP;</pre>
	<pre>RMAN&gt; RESTORE CONTROLFILE FROM TAG 'monday_cf_backup';</pre>
	<pre>RMAN&gt; RESTORE CONTROLFILE FROM '/u01/ control01.ctl';</pre>
	<pre>RMAN&gt; RESTORE CONTROLFILE VALIDATE;</pre>



**Table B-1 (Cont.) Commonly Used RMAN Command Examples**

Operation	Command Example
	<pre> RMAN&gt; RESTORE CONTROLFILE TO '/tmp/autobkp.dbf' FROM AUTOBACKUP MAXSEQ 20 MAXDAYS 150; </pre>
	<pre> RMAN&gt; RESTORE SPFILE; </pre>
	<pre> RMAN&gt; RESTORE SPFILE FROM AUTOBACKUP; </pre>
	<pre> RMAN&gt; RESTORE ARCHIVELOG ALL VALIDATE; </pre>
	<pre> RMAN&gt; RESTORE ARCHIVELOG ALL PREVIEW; </pre>
	<pre> RMAN&gt; RESTORE ARCHIVELOG ALL PREVIEW RECALL; </pre>
	<pre> RMAN&gt; RESTORE ARCHIVELOG ALL DEVICE TYPE SBT PREVIEW; </pre>
	<pre> RMAN&gt; RESTORE ARCHIVELOG LOW LOGSEQ 78311 HIGH LOGSEQ 78340 THREAD 1 ALL; </pre>
	<pre> RMAN&gt; RESTORE ARCHIVELOG FROM LOGSEQ=&lt;seq_no&gt; UNTIL LOGSEQ=&lt;seq_no&gt;; </pre>
	<pre> RMAN&gt; RESTORE STANDBY CONTROLFILE FROM TAG 'forstandby'; </pre>
	<pre> RMAN&gt; RESTORE CLONE CONTROLFILE TO '+DATA/pcrd/data2/control02.ct1' FROM '+DATA/pcrd/data1/control01.ct1'; </pre>
	<pre> RMAN&gt; RESTORE DATABASE VALIDATE HEADER PREVIEW; </pre>
	<pre> RMAN&gt; RESTORE PLUGGABLE DATABASE root, pdb1, pdb2; </pre>
	<pre> RMAN&gt; RESTORE PLUGGABLE DATABASE root, pdb1, pdb2 SKIP FOREVER TABLESPACE pdb:ts_name, pdb:ts_name, pdb:ts_name; </pre>

Table B-1 (Cont.) Commonly Used RMAN Command Examples

Operation	Command Example
	<p><i>To restore a control file and then restore the database using the control file:</i></p> <pre>STARTUP NOMOUNT; RUN { ALLOCATE CHANNEL c1 DEVICE TYPE sbt; RESTORE CONTROLFILE; ALTER DATABASE MOUNT; RESTORE DATABASE; }</pre>
SPOOL	<pre>RMAN&gt; SPOOL LOG TO '/tmp/spool.log';</pre> <pre>RMAN&gt; SPOOL LOG TO '/tmp/backup.log' APPEND;</pre> <pre>RMAN&gt; SPOOL LOG OFF;</pre> <p><i>Write RMAN output to a trace (.trc) file and then choose to enable debug. This operation provides <code>stdio</code> and a log. If you enable debug in RMAN, then the output to trace will include the debug output from RMAN.</i></p> <pre>RMAN&gt; SPOOL TRACE TO '/tmp/spool.trc';</pre> <pre>RMAN&gt; SPOOL TRACE TO '/tmp/backup.trc' APPEND;</pre> <pre>RMAN&gt; SPOOL TRACE OFF;</pre>

**Table B-1 (Cont.) Commonly Used RMAN Command Examples**

Operation	Command Example
<b>SWITCH</b>	<pre> RMAN&gt; SWITCH DATABASE TO COPY;  RMAN&gt; SWITCH TABLESPACE users to copy;  RMAN&gt; SWITCH DATAFILE ALL;  RMAN&gt; SWITCH DATAFILE '/disk1/tols.dbf' TO DATAFILECOPY '/disk2/tols.copy';  RMAN&gt; SWITCH DATAFILE "+dg_old/db/datafile/ sysaux.260.699468081" TO COPY;  RMAN&gt; SWITCH TEMPFILE 1;  RMAN&gt; SWITCH TEMPFILE 1 TO '/newdisk/dbs/ templ.f';  RMAN&gt; SWITCH TEMPFILE ALL;  RMAN&gt; SWITCH CLONE DATAFILE ALL;</pre>
<b>TRANSPORT TABLESPACE</b>	<pre> RMAN&gt; TRANSPORT TABLESPACE example, tools TABLESPACE DESTINATION '/disk1/trans' AUXILIARY DESTINATION '/disk1/aux' UNTIL TIME 'sysdate-15/1440';  RMAN&gt; TRANSPORT TABLESPACE exam TABLESPACE DESTINATION '/disk1/trans' AUXILIARY DESTINATION '/disk1/aux' DATAPUMP DIRECTORY dpdir DUMP FILE 'dmpfile.dmp' IMPORT SCRIPT 'impscript.sql' EXPORT LOG 'explog.log';</pre>

**Table B-1 (Cont.) Commonly Used RMAN Command Examples**

Operation	Command Example
VALIDATE	RMAN> VALIDATE BACKUPSET 3871, 3890;
	RMAN> VALIDATE DATABASE;
	RMAN> VALIDATE CHECK LOGICAL DATABASE;
	RMAN> VALIDATE SKIP INACCESSIBLE DATABASE;
	RMAN> VALIDATE COPY OF DATABASE;
	RMAN> VALIDATE TABLESPACE DATA;
	RMAN> VALIDATE COPY OF TABLESPACE DATA;
	RMAN> VALIDATE DATAFILE 2;
	RMAN> VALIDATE DATAFILE 4,8;
	RMAN> VALIDATE DATAFILE 4 BLOCK 56;
	RMAN> VALIDATE DATAFILE 8 SECTION SIZE = 200M;
	RMAN> VALIDATE CURRENT CONTROLFILE;
	RMAN> VALIDATE SPFILE;
	RMAN> VALIDATE RECOVERY FILES;
	RMAN> VALIDATE CHECK LOGICAL RECOVERY FILES;
	RMAN> VALIDATE RECOVERY AREA;
	RMAN> VALIDATE CHECK LOGICAL RECOVERY AREA;
	RMAN> VALIDATE DB_RECOVERY_FILE_DEST;
	RMAN> VALIDATE CHECK LOGICAL DB_RECOVERY_FILE_DEST;
	<i>Validate Mirror</i>

**Table B-1 (Cont.) Commonly Used RMAN Command Examples**

Operation	Command Example
	RMAN> VALIDATE DATAFILE 1 MIRROR ALL;
	RMAN> VALIDATE DATAFILE 1 MIRROR 1;
	RMAN> VALIDATE DATAFILE 1 MIRROR 2;
	RMAN> VALIDATE DATAFILE 1 MIRROR 3;

# C

## Deprecated RMAN Syntax

This appendix describes Recovery Manager syntax that is deprecated and describes preferred syntax if any exists.

Deprecated RMAN syntax continues to be supported in subsequent releases for backward compatibility. For example, the `SET AUXNAME` command replaced the `SET CLONENAME` command in Oracle8i, and the `CONFIGURE AUXNAME` command replaced the `SET AUXNAME` command in Oracle9i. However, you can continue to run both `SET CLONENAME` and `SET AUXNAME` in all subsequent RMAN releases.

**Table C-1** *Deprecated RMAN Syntax*

Deprecated in Release	Deprecated Syntax	Preferred Current Syntax
19c	ADVISE FAILURE	n/a
19c	CHANGE FAILURE	n/a
19c	LIST FAILURE	n/a
19c	REPAIR FAILURE	n/a
12.1	ALTER DATABASE	n/a
11.2.0	CONFIGURE or SET COMPRESSION ALGORITHM 'ZLIB'	CONFIGURE or SET COMPRESSION ALGORITHM 'MEDIUM'
11.2.0	CONFIGURE or SET COMPRESSION ALGORITHM 'BZIP2'	CONFIGURE or SET COMPRESSION ALGORITHM 'BASIC'
11.2.0	V\$FLASH_RECOVERY_AREA_USAGE	V\$RECOVERY_AREA_USAGE
11.1.0	CONVERT ON TARGET PLATFORM	CONVERT ON DESTINATION PLATFORM
11.1.0	UNTIL RESTORE POINT	TO RESTORE POINT
11.1.0	BACKUP ... AS STANDBY	n/a
11.1.0	... KEEP [LOGS   NOLOGS]	... KEEP
11.1.0	BLOCKRECOVER	RECOVER
10.0.1	BACKUP ... INCREMENTAL LEVEL [2,3,4]	Levels <i>other than</i> 0 and 1 are deprecated.
10.0.1	BACKUP ... PARMS	CONFIGURE CHANNEL ... PARMS
10.0.1	COPY	BACKUP AS COPY
10.0.1	CREATE CATALOG TABLESPACE	CREATE CATALOG
10.0.1	LIST ... BY BACKUP [SUMMARY]	n/a
10.0.1	LIST ... VERBOSE	n/a
10.0.1	RESTORE ... PARMS	CONFIGURE CHANNEL ... PARMS
10.0.1	SEND ... PARMS	CONFIGURE CHANNEL ... PARMS
9.2	REPLICATE	RESTORE CONTROLFILE FROM ...
9.2	SET AUTOLOCATE	Enabled by default

Table C-1 (Cont.) *Deprecated RMAN Syntax*

Deprecated in Release	Deprecated Syntax	Preferred Current Syntax
9.0.1	ALLOCATE CHANNEL FOR DELETE	n/a
9.0.1	ALLOCATE CHANNEL ... TYPE	CONFIGURE CHANNEL ... DEVICE TYPE
9.0.1	ALLOCATE CHANNEL ... KBYTES	CONFIGURE CHANNEL ... MAXPIECESIZE
9.0.1	ALLOCATE CHANNEL ... READRATE	CONFIGURE CHANNEL ... RATE
9.0.1	... ARCHIVELOG ... LOGSEQ	... ARCHIVELOG ... SEQUENCE
9.0.1	BACKUP ... SETSIZE	BACKUP ... MAXSETSIZE
9.0.1	CHANGE ... CROSSCHECK	CROSSCHECK
9.0.1	CHANGE ... DELETE	DELETE
9.0.1	REPORT ... AT LOGSEQ	REPORT ... AT SEQUENCE
9.0.1	SET AUXNAME	CONFIGURE AUXNAME
9.0.1	SET DUPLEX	SET BACKUP COPIES CONFIGURE BACKUP COPIES
9.0.1	SET LIMIT CHANNEL ...	ALLOCATE CHANNEL ... CONFIGURE CHANNEL ...
9.0.1	SET SNAPSHOT	CONFIGURE SNAPSHOT
9.0.1	UNTIL LOGSEQ (see <a href="#">untilClause</a> )	UNTIL SEQUENCE (see <a href="#">untilClause</a> )
8.1.7	CONFIGURE COMPATIBLE	n/a
8.1.5	ALLOCATE CHANNEL CLONE	CONFIGURE AUXILIARY CHANNEL
8.1.5	CHANGE ... VALIDATE	CROSSCHECK
8.1.5	CLONE (see <a href="#">RMAN</a> )	AUXILIARY (see <a href="#">RMAN</a> )
8.1.5	CONFIGURE CLONE	CONFIGURE AUXILIARY
8.1.5	MSGLOG (see <a href="#">RMAN</a> )	LOG (see <a href="#">RMAN</a> )
8.1.5	RCVCAT (see <a href="#">RMAN</a> )	CATALOG (see <a href="#">RMAN</a> )

# D

## RMAN Compatibility

This appendix describes the requirements for compatibility among the different components of the Recovery Manager (RMAN) environment. This appendix contains these topics:

- [About RMAN Compatibility](#)
- [Determining the Recovery Catalog Schema Version](#)
- [RMAN Compatibility Matrix](#)
- [Cross-Version Compatibility of Recovery Catalog Exports and Imports](#)
- [RMAN Compatibility: Scenario](#)



### See Also:

*Oracle Database Upgrade Guide*

### D.1 About RMAN Compatibility

[Table D-1](#) describes the components of an RMAN environment. Each component has a release number associated with it.

**Table D-1 Components of an RMAN Environment**

Component	Release Number Refers to ...
RMAN client	Version of RMAN client (displayed when you start RMAN)
Recovery catalog database	Version of Oracle Database
Recovery catalog schema in recovery catalog database	Version of RMAN client used to create the recovery catalog
Target database	Version of Oracle Database
Auxiliary database	Version of Oracle Database

Starting with Oracle Database 12c, the version of the RMAN client, target database, and auxiliary database must be the same. The recovery catalog schema can be any supported catalog schema whose version is greater than the version of the RMAN client. For example an Oracle Database 12c RMAN client can only connect to a target database whose version is Oracle Database 12c, an auxiliary database whose version is Oracle Database 12c, and a recovery catalog schema that is created in an Oracle Database 12c or higher version.

### D.2 Determining the Recovery Catalog Schema Version

Use a SQL query to determine the version of the recovery catalog schema.

To determine the current release of the recovery catalog schema:



1. Use SQL\*Plus to connect to the recovery catalog database as the catalog owner. For example, enter:

```
% sqlplus rco@catdb
```

2. Query the `rcver` catalog table. For example, run this query:

```
SQL> SELECT * FROM rcver;
```

```
VERSION
-----
12.01.00.01
```

## D.3 RMAN Compatibility Matrix

There are certain rules for RMAN compatibility.

Rules for RMAN compatibility include:

- The version of the RMAN client must be equal to the version of the target database.
- The version of the auxiliary database must be equal to the version of the RMAN client.
- The version of the recovery catalog schema must be greater than or equal to the version of the RMAN client.
- If the recovery catalog is a **virtual private catalog** (see [CREATE CATALOG](#)), then the version of the RMAN client connecting to it must be Oracle Database 10g Release 1 (10.1.0.6) or Oracle Database 10g Release 2 (10.2.0.3). Oracle 9i RMAN clients cannot connect to a virtual private catalog. This version restriction does not affect RMAN client connections to an Oracle Database 11g base recovery catalog, even if the base catalog has virtual private catalog users.
- While backing up an Oracle Database 10g or later release with the Oracle9i RMAN client, you cannot include a control file that was created using `COMPATIBLE=10.0.0` in a data file backup set. The workaround is to turn control file autobackup ON.
- Any release of Oracle Database can restore backup sets and copies created by any prior Oracle Database release.

[Table D-2](#) shows version-specific requirements for RMAN components. The symbol `>=` before a release means all Oracle Database releases from this release or later along with their patches.

**Table D-2 RMAN Compatibility Table**

Target/ Auxiliary Database version	RMAN client version	Recovery Catalog Database version	Recovery Catalog Schema version
11.1.0	<code>&gt;= 10.1.0.5</code> and <code>&lt;= target</code> database executable	<code>&gt;= 11.0</code> (with <code>COMPATIBLE</code> parameter <code>&gt;=11.0</code> )	<code>&gt;= RMAN client version</code>

Table D-2 (Cont.) RMAN Compatibility Table

Target/ Auxiliary Database version	RMAN client version	Recovery Catalog Database version	Recovery Catalog Schema version
11.2.0	>= 10.1.0.5 and <= target database executable	>= 11.0 (with COMPATIBLE parameter >=11.0)	>= RMAN client version
>= 12.1.0.x	= target database executable	>= 11.0 (with COMPATIBLE parameter >=11.0)	>= RMAN client version
18.x	= target database executable	>= 11.0 (with COMPATIBLE parameter >=11.0)	>= RMAN client version
19.x	= target database executable	>= 11.0 (with COMPATIBLE parameter >=11.0)	>= RMAN client version
20.x	= target database executable	>= 11.0 (with COMPATIBLE parameter >=11.0)	>= RMAN client version
21.x	= target database executable	>= 11.0 (with COMPATIBLE parameter >=11.0)	>= RMAN client version

When using an older version of the RMAN client with a newer version of the database, you do not get the features added in the newer version.

## D.4 Cross-Version Compatibility of Recovery Catalog Exports and Imports

Data Pump Exports of the recovery catalog are often used as a way to backup its contents. When planning to use Data Pump Export to make a logical backup of the recovery catalog, certain compatibility issues relating to the use of database exports across versions of Oracle Database must be kept in mind.

Exports from a later version of the database cannot be imported into databases running under earlier versions. You must export your recovery catalog data using the export utility from the earliest version of Oracle Database that you use for a recovery catalog.

For example, to export the recovery catalog data from an Oracle Database 11g Release 2 (11.2) database and import it into an Oracle Database 10g Release 1 (10.1.0.5) database for disaster recovery, you must use the export utility from Oracle Database 10g Release 1 (10.1.0.5) to perform the export operation. Otherwise, the import operation fails.

 **See Also:**

*Oracle Database Utilities* for details on compatibility issues relating to the use of database exports across versions of Oracle Database

## D.5 RMAN Compatibility: Scenario

This section contains an example of the RMAN client versions and recovery catalog database versions used for production databases that use various Oracle Database versions.

Assume that you maintain a production databases of the following releases:

- Oracle Database 11g Release 1 (11.2)
- Oracle Database 12c Release 1(12.1)
- Oracle Database 12c Release 2(12.2)
- Oracle Database release 18c, version 18.1

You want to record RMAN repository data about these databases in a single recovery catalog database. According to [RMAN Compatibility Matrix](#), you can use a single recovery catalog database whose version is Oracle Database Release 18c with a catalog schema whose version is Oracle Database Release 18c for all target databases.

Ensure that the version of the RMAN client used to back up each target database meets the following requirements:

- Use the Oracle Database 11g Release 1 (11.2) RMAN client to back up the Oracle Database 11g Release 1 (11.2) database.
- Use the Oracle Database 12c Release 1 (12.1) RMAN client to back up the Oracle Database 12c Release 1 (12.1) database.
- Use the Oracle Database 12c Release 2 (12.2) RMAN client to back up the Oracle Database 12c Release 2 (12.2) database.
- Use the Oracle Database release 18c version 18.1 RMAN client to back up the Oracle Database Release 18c database.

# E

## Oracle Database Cloud Backup Module

Oracle Database Cloud Backup Module enables you to back up Oracle databases to Oracle Cloud Infrastructure Object Storage by using the Oracle Database Backup Cloud Service.

Oracle Database Backup Cloud Service is the storage solution for backups and restores of Oracle databases with Oracle Cloud. Oracle Database Cloud Backup Module is an SBT interface that is integrated with Recovery Manager (RMAN). Database backups are created using RMAN and the Oracle Database Cloud Backup Module sends these backups, over the network, to Oracle Database Backup Cloud Service for offsite storage.

### See Also:

*Using Oracle Database Backup Cloud Service* for information about installing Oracle Database Cloud Backup Module and backing up Oracle databases to Oracle Cloud

# F

## Oracle Secure Backup (OSB) Cloud Module

The Oracle Secure Backup (OSB) Cloud Module enables you to take advantage of internet-based data storage services offered by Amazon Simple Storage Service (S3) for RMAN backup and recovery tasks.

This appendix contains the following topics:

- [About Backup on the Cloud Using Oracle Secure Backup Cloud Module](#)
- [Using Oracle Secure Backup Cloud Module on Amazon S3](#)
- [Securing OSB Cloud Module Backups](#)
- [Helpful Links: Oracle Secure Backup Cloud Module](#)
- [Troubleshooting the OSB Cloud Module](#)

### F.1 About Backup on the Cloud Using Oracle Secure Backup Cloud Module

The Oracle Secure Backup Cloud Module is part of the Oracle Secure Backup product family and provides the flexibility to back up your database to the Amazon S3 Cloud and to tape. With this cloud offering, local disk backups are sent directly to Amazon S3 for offsite storage and are fully integrated with Recovery Manager (RMAN) features and functionality.

The Oracle Secure Backup Cloud Module efficiently handles the backing up of Oracle databases to S3 storage. You can backup Oracle databases starting with Oracle Database 9*i* Release 2 or higher. In addition, Oracle Secure Backup Cloud Module backups work with tools like Oracle Enterprise Manager and your customized RMAN scripts. The Oracle Secure Backup Cloud Module does not back up operating system files.

The Oracle Secure Backup Cloud Module uses the RMAN SBT (System Backup to Tape) interface to extend the Amazon S3 functionality for Oracle backup operations. The Oracle Secure Backup Cloud Module offers an easy-to-manage, cost efficient, and scalable alternative to maintaining in-house data storage and managing a local, fully configured backup infrastructure.

The Oracle Secure Backup Cloud Module has several advantages over traditional tape-based offsite backups:

- Continuous Accessibility

Oracle Secure Backup Cloud Module backups stored on Amazon S3 storage are always accessible. The cloud storage services availability and access model helps an organization to streamline recovery operations. For example, there is no need to ship or load tapes before a restore can be performed. You can still use familiar and standard tools like Enterprise Manager and your organization's current scripts continue to execute backup and restore tasks. With the ability to continually and easily access backups, the time spent restoring backups may be substantially reduced.

- Improved Reliability

Because S3 storage is disk based, it is inherently more reliable than tape media. Internet storage service providers keep multiple, redundant copies of your data for availability and scalability purposes and the benefit of this practice to your organization and your data is increased reliability.

## F.1.1 Configuration Parameters for the Oracle Secure Backup Cloud Module

Use configuration parameters to specify the settings that are used when performing backups with the Oracle Secure Backup Cloud Module.

Configuration parameters can be set in one of the following locations:

- Configuration file for the Oracle Secure Backup Cloud Module  
The name of the configuration file is specified in the `OSB_WS_PFILE` parameter
- ENV variable when configuring SBT channels

The following table describes the configuration parameters that can be set when using the Oracle Secure Backup Cloud Module.

Parameter Name	Mandatory ?	Description
<code>OSB_WS_PFILE</code>	No	Indicates the configuration file for the SBT library. The default location for the configuration file is: Linux: <code>?/dbs/osbwsORACLE_SID.ora</code> Windows: <code>?\database\osbwsORACLE_SID.ora</code> Here, ? represents the <code>ORACLE_HOME</code> and <code>ORACLE_SID</code> represents the SID of the target database.
<code>OSB_WS_HOST</code>	Yes	Specifies the name of the host to which the backups are sent.
<code>OSB_WS_PROXY</code>	No	Specifies the proxy server and port when the target database is behind a firewall. It is specified in the <code>&lt;host&gt;:&lt;port&gt;</code> format.
<code>OSB_WS_BUCKET</code>	No	Specifies the bucket in which the SBT library stores backups. If this parameter is not specified, then the SBT library first attempts to find an existing bucket whose location matches the specified location from buckets whose names are prefixed with <code>oracle-data-account name-</code> . If no such bucket exists, then the SBT library creates a unique bucket with the above prefix.
<code>OSB_WS_LOCATION</code>	No	Specifies the Amazon S3 location where the backups must be stored. This value must match the location of the specified <code>OSB_WS_HOST</code> and the location of the <code>OSB_WS_BUCKET</code> (if specified). If this parameter is not specified, then the default Amazon S3 region is used.  Refer to the Amazon S3 documentation for a list of valid pairs of endpoints and locations.

Parameter Name	Mandatory ?	Description
OSB_WS_CHUNK_SIZE	No	Specifies the object size, in bytes, that will be used when storing backups to Amazon S3. The default size is 100MB.
OSB_WS_LICENSE_ID	No	Specifies the unique license ID generated during installation for each AWS account. The current installer does not perform registration and therefore, this parameter is available only for compatibility reasons.
OSB_WS_LICENSE_MAX_SESSIONS	No	Specifies the number of connection sessions that can run. The SBT library does not allow you to create more than the specified number of sessions at any given time.
OSB_WS_WALLET	Yes	Defines the wallet location, alias, and proxy authentication alias through which the SBT library reads credentials. The format of this parameter is: LOCATION=<filename> CREDENTIAL_ALIAS=<alias> PROXY_AUTH_ALIAS=<alias> LOCATION defines the location of wallet, CREDENTIAL_ALIAS defines the alias in the wallet from which AWS credentials are retrieved, and PROXY_AUTH_ALIAS defines the alias in the wallet from which the proxy authentication credentials are retrieved. PROXY_AUTH_ALIAS is optional, the others are mandatory.
OSB_WS_VIRTUAL_HOST	No	Specifies the format of the host. The default value is TRUE. When set to TRUE, the format is http[s]://<bucket>.<host>. When set to FALSE, the format is http[s]://<host>/<bucket>. Use FALSE when the storage provider is not Amazon S3, but is compatible with S3.
OSB_WS_IAM_ROLE	Yes, when using the metadata service.	Specifies the name of the IAM role that can be used to back up to Amazon S3. The Amazon EC2 instance must be configured with the specified IAM role.
OSB_WS_IAM_ROLE_METADATA_URI	No	Specifies the name of the metadata URI where temporary credentials for the IAM role are stored.
OSB_WS_PRIVATE_CLOUD	No	This parameter is the same as OSB_WS_VIRTUAL_HOST. It is obsolete and is available only for compatibility reasons.

## F.2 Using Oracle Secure Backup Cloud Module on Amazon S3

To use Oracle Secure Backup Cloud Module on Amazon S3, you must set up an Amazon Web Services (AWS) account. You also need the S3 Backup installer and a compatible version of Java software.

Here are the steps to set up, install, verify and run the Oracle Secure Backup Cloud Module:

Steps	Description
1	<a href="#">Hardware and Software Prerequisites for Oracle Secure Backup Cloud Module</a>
2	<a href="#">Signing Up For Amazon S3 - AWS Account</a>
3	<a href="#">Getting Your AWS Identifiers</a>
4	<a href="#">Installing the OSB Cloud Module Library</a>
5	<a href="#">Running the S3 Backup Installer</a> <ul style="list-style-type: none"> <li>• <a href="#">Verifying Java Version</a></li> <li>• <a href="#">Verifying \$ORACLE_HOME</a></li> </ul>
6	<a href="#">Storing Configuration Information in the RMAN Repository (Optional)</a>
7	<a href="#">Using the OSB Web Services Library and First Backup</a>

## F.2.1 Hardware and Software Prerequisites for Oracle Secure Backup Cloud Module

Certain hardware and software requirements must be met to use the Oracle Secure Backup Cloud module.

The following table lists the prerequisites for the Oracle Secure Backup Cloud Module:

Hardware/Software	Version
Java	Java 1.7 or later on the computer where you plan to run the S3 Backup Installer
Supported Platforms	<ul style="list-style-type: none"> <li>• Linux x86-64</li> <li>• Microsoft Windows (64-bit)</li> <li>• Oracle Solaris on SPARC (64-bit)</li> <li>• Oracle Solaris X64</li> <li>• ZLinux-64</li> <li>• AIX (PPC64)</li> <li>• HP-UX IA64</li> </ul> <p><b>Note:</b> HP-UX PA-RISC 64-bit is not supported.</p>
Oracle Database	You can backup databases starting with Oracle Database 9 <i>i</i> Release 2 or later. Operating system files cannot be backed up with RMAN or the RMAN SBT interface.



Hardware/Software	Version
S3 Backup Installer File	<p>osbws_install.jar</p> <p>The installer downloads the library that is appropriate for the platform it is running on. It also creates the library configuration file and the Oracle Wallet where the AWS credentials are stored.</p> <p>If you are using Oracle provided Amazon Machine Images (AMIs) to run the Oracle Database on Amazon's Elastic Compute Cloud (EC2), then the installer can be found in the <code>/home/oracle/scripts</code> directory. Otherwise, you can download the file from the Cloud Computing Center link found on the Oracle Technical Network (OTN) website at <a href="http://www.oracle.com/technetwork/products/secure-backup/secure-backup-s3-484709.html">http://www.oracle.com/technetwork/products/secure-backup/secure-backup-s3-484709.html</a></p> <p>Oracle recommends that users include any of the command-line options in a file and secure the file with appropriate operating system permissions. The S3 Backup Installer can then read the file, invoke the options, and prohibit unauthorized users from reading the file.</p>
Oracle Wallet Directory	<p>The Oracle Wallet Directory stores your AWS identifiers and must exist before you can run the S3 Backup installer. If you have not set up a wallet directory then you must create one.</p> <p>Here are the suggested platform-specific locations for the wallet directory:</p> <ul style="list-style-type: none"> <li>Linux: <code>\$ORACLE_HOME/dbs/osbws_wallet</code></li> <li>Windows: <code>\$ORACLE_HOME\database\osbws_wallet</code></li> </ul>
System Time	<p>The authentication method used by S3 relies on the client's system time being similar to S3's time. In this case, the client is the computer where you run the OSB Web Services library. S3 time is Coordinated Universal Time (UTC), so you must ensure that the system time on your client is within a few minutes of UTC.</p>

## F.2.2 Registering for An Oracle Technology Network (OTN) Account

You need an OTN account for downloading the S3 Backup installer for the OSB Cloud Module.

If you do not have an OTN account, you may register for one at: <http://www.oracle.com/technetwork/community/join/overview/index.html>

You can download the installer from the OTN Cloud Computing Center home page.

## F.2.3 Signing Up For Amazon S3 - AWS Account

Before you can use the Oracle Secure Backup Cloud Backup Module and access Amazon S3, you must create an AWS account.

You can open one at: <http://aws.amazon.com>. Click **My Account** and then select **Security Credentials**.

The account requires that you provide a means of payment for Amazon to charge for your AWS S3 usage.

## F.2.4 Getting Your AWS Credentials

AWS credentials are required to back up to Amazon S3.

You can use one of the following techniques to authenticate and access Amazon S3:

- **AWS Identifiers**

You obtain these credentials by going to the AWS website at <http://aws.amazon.com>, selecting **My Account**, and then **AWS Management Console**.

You need the following mandatory AWS identifiers that are assigned when you create your AWS account: Access Key ID and Secret Access Key.

**Note:** It is a good idea to secure these credentials since they authorize charges for all Amazon Web Services and enable access to RMAN backups stored on Amazon S3.

- **AWS IAM role**

Enables Amazon Elastic Cloud Compute (EC2) instance users to leverage the metadata service. When the EC2 instance is configured with an IAM role, applications running on EC2 can use temporary credentials associated with the IAM role to create backups to Amazon S3. EC2 stores the temporary credentials in a predetermined location in JSON format. The installer retrieves the temporary credentials and stores them in the Oracle wallet.

The IAM role must have the privileges required to access Amazon S3.

Provide the following parameters to use IAM roles: AWS IAM Role Name (mandatory) and Metadata URI for the specified IAM Role (optional).

 **See Also:**

For more information about IAM roles for Amazon EC2, refer to: <http://docs.aws.amazon.com/AWSEC2/latest/UserGuide/iam-roles-for-amazon-ec2.html>

## F.2.5 Installing the OSB Cloud Module Library

The Oracle Secure Backup Cloud Module library needs to be installed before you can back up databases to Amazon S3 Cloud.

If this is the first time you run the S3 Backup installer, Oracle recommends that you run it initially without any parameters to get a listing and explanation of the mandatory and optional parameters. Analyzing and reviewing this information before executing the S3 Backup installer helps to ensure a successful installation.

To run the S3 Backup installer without parameters, type:

```
% java -jar osbws_install.jar
```

The following table provides an explanation for the various parameters used during installation.

**Table F-1 Parameters Used when Installing the OSB Cloud Module Library**

Parameter Name	Description	Mandatory?
AWSID	Access Key ID for the Amazon Web Services account that is used to store RMAN backups.	Yes, if you use AWS identifiers to authenticate with Amazon S3.
AWSKey	Secret access key for the Amazon Web Services account specified in <code>-AWSID</code> . <b>Note:</b> To authenticate with Amazon S3, you must provide one of the following: <ul style="list-style-type: none"> <li>• <code>AWSID</code> along with <code>AWSKey</code></li> <li>• <code>IAMRole</code></li> </ul>	Yes, if you use AWS identifiers to authenticate with Amazon S3.
IAMRole	AWS IAM (Identity and Access Management) role name that contains the temporary credentials that RMAN will use for backup and recovery operations. This role must be assigned the appropriate privilege to access your S3 account. <b>Note:</b> To authenticate with Amazon S3, you must provide one of the following: <ul style="list-style-type: none"> <li>• <code>IAMRole</code></li> <li>• <code>AWSID</code> along with <code>AWSKey</code></li> </ul>	Yes, if you use IAM roles to authenticate with Amazon S3.
IAMRoleMetaURI	Metadata URI where temporary credentials for the specified IAM role are stored. For Amazon EC2 users, specifying the metadata URI is optional. If this parameter is omitted, the temporary credentials are retrieved from the instance metadata.	No
awsEndpoint	Host name to which backups must be sent. If this parameter is omitted, backups will be stored on the default host.	No
awsPort	Non-default HTTP/HTTPS connection port number. The default port number for HTTP is 80 and HTTPS is 443.	No
location	Amazon S3 location where the RMAN backups must be stored. If specified, the value must match the location of the value of <code>awsEndPoint</code> . For third-party S3-compatible services, if a location is not required, set location to "us". Refer to the Amazon S3 documentation for a list of valid locations..	No
walletDir	Location that stores the Oracle wallet that contains S3 credentials and proxy information. The Oracle wallet directory must exist before running the S3 Backup installer. Consult <a href="#">Hardware and Software Prerequisites for Oracle Secure Backup Cloud Module</a> for more information.	Yes

**Table F-1 (Cont.) Parameters Used when Installing the OSB Cloud Module Library**

Parameter Name	Description	Mandatory?
configFile	<p>Name, with the complete path, of the configuration file that will be created by the installer. The parameters that are used while running RMAN jobs are obtained from this configuration file.</p> <p>If this parameter is omitted, the installer creates the configuration file and places it in a default system-dependent location.</p> <p>Default Linux location: \$ORACLE_HOME/dbs/osbsws&lt;ORACLE_SID&gt;.ora</p> <p>Default Windows location: \$ORACLE_HOME\database\osbsws&lt;ORACLE_SID&gt;.ora</p>	No
libDir	<p>Directory into which the OSB Cloud Module library is downloaded. If this parameter is omitted, the installer does not download the library.</p> <p>Suggested Linux location: \$ORACLE_HOME/lib/</p> <p>Suggested Windows location: \$\$ORACLE_HOME\bin\</p>	No
libPlatform	<p>Platform on which the library must be installed.</p> <p>The install tool determines the platform automatically by examining the system where it is running. This parameter allows specifying it explicitly.</p> <p>Supported values for the parameter are: linux64, windows64, solaris_sparc64, solaris_x64, hpux_ia64</p> <p><b>Note:</b> The install tool determines the platform automatically by examining the system where it is running. This parameter allows specifying it explicitly.</p>	No
proxyHost	<p>Name of the HTTP proxy server, if required. If the proxy server is specified, then the -proxyID and -proxyPass parameters are required.</p>	No
proxyPort	<p>Port number of the HTTP proxy server.</p>	No
proxyID	<p>User name for the HTTP proxy server.</p>	No
proxyPass	<p>Password for the HTTP proxy server user</p>	No
trustedCerts	<p>List of SSL certificate to be imported into the Oracle wallet.</p>	No
argFile	<p>Name of the file from which arguments must be read during installation. To read arguments from the standard input, specify "-".</p>	No
useHttps	<p>Sets up an HTTPS connection. If omitted, and HTTP connection is used.</p>	No
useSigV2	<p>Sets up an authentication scheme. If this parameter is specified, Signature Version 2 authentication is set up; else Signature Version 4 is set up. The recommended scheme is Signature Version 4.</p>	No

Check and collect the relevant information for any optional parameters that you want to include. For example, you may need to know the proxy server name, port and credentials of your installation.

At this point, you are ready to execute the installer.

## F.2.6 Running the S3 Backup Installer

Oracle recommends running the Java installer in a secure mode, so avoid running it directly from the command line.

A preferred method is to include the command-line options in a file and secure access to the file with the appropriate operating system permissions:

```
% java -jar osbws_install.jar -ARGFILE filename
```

Another method is to embed the run command, parameters and values in a file that can be executed as either a shell script or a Windows batch file.

Follow these steps:

- Create a file
- Set file permissions to grant owner of the file exclusive access

 **Note:**

Setting the file permissions to restrict access is critical since the file contains AWS credentials.

- Edit the file to contain a single line with the installer's run command and the mandatory parameters. You can compose a one-line invocation by populating the parameters with the information you obtained in the previous section.
- Execute the file as a shell script or Windows batch file

**Note:** To make the following example easier to read, `$ORACLE_HOME` is set to `/orclhome`. In your installation, the value of `$ORACLE_HOME` is something like `/usr/oracle/product/11.2.0` (Linux).

### Example F-1 Running the S3 Backup Installer Using AWS Credentials

The following shows a sample run of the S3 Backup installer under Linux.

The first thing to do is to verify that the correct version of Java is present on the computer and that `$ORACLE_HOME` is defined.

Enter the following commands and review the output:

```
% java -version
java version "1.7.0"
Java(TM) SE Runtime Environment (build 1.7.0-b147)
Java HotSpot(TM) 64-Bit Server VM (build 21.0-b17, mixed mode)

% echo $ORACLE_HOME
/orclhome
```

Create a file that contains the installer's invocation line and ensure that the file permissions restrict access except to the file owner.

```
% touch osbws.sh
% chmod 700 osbws.sh
```

Edit the file and add a line to invoke the installer. This example uses AWS identifiers to authenticate.

```
java -jar osbws_install.jar -AWSID access key ID -AWSKey secret key -  
walletDir $ORACLE_HOME/dbs/osbws_wallet -libDir $ORACLE_HOME/lib/ -proxyHost www-  
proxy.example.com
```

Execute the file.

```
% ./osbws.sh
```

Here is the start of the S3 Backup installer output:

```
AWS credentials are valid.  
Oracle Secure Backup Web Service wallet created in directory /  
orclhome/dbs/osbws_wallet.  
Oracle Secure Backup Web Service initialization file /orclhome/dbs/  
osbwst1.ora created.  
Downloading OSB Web Services Software Library.  
Downloaded 13165919 bytes in 204 seconds. Transfer rate was 64538  
bytes/second.  
Download complete.  
Extracted file /orclhome/lib/libosbws.so
```

When the installer completes, you should have these three files on your system:

1. The OSB Web Services Library
2. The Configuration file
3. The OSB Web Services Wallet

**Note:** The installer requires the AWS credentials to create the wallet and perform other installation operations. Only your AWS credentials are retained when the installer has finished and they are stored in the Oracle Wallet. The AWS credentials are used solely to authenticate the library's interactions with S3 and are not used or sent anywhere else.

### Example F-2 Running the S3 Installer Using an IAM Role

This example shows a sample run of the S3 Backup installer on Linux using an IAM role names `s3access`.

```
java -jar osbws_install.jar -IAMRole s3access walletDir $ORACLE_HOME/dbs/  
osbws_wallet -libDir $ORACLE_HOME/lib/ -proxyHost www-proxy.example.com
```

Here is the start of the S3 installer output.

```
AWS credentials are valid.  
Oracle Secure Backup Web Service wallet created in directory /  
orclhome/dbs/osbws_wallet.  
Oracle Secure Backup Web Service initialization file /orclhome/dbs/  
osbwst1.ora created.  
Downloading OSB Web Services Software Library.  
Downloaded 13165919 bytes in 204 seconds. Transfer rate was 64538  
bytes/second.  
Download complete.  
Extracted file /orclhome/lib/libosbws.so
```

## F.2.7 Storing Configuration Information in the RMAN Repository (*Optional*)

To avoid having to provide the configuration information each time a backup is invoked, it is a good idea to store the Oracle Secure Backup Cloud Module configuration information in the RMAN repository.

This example is for a pre-11g Release 2 database:

```
RMAN> configure channel device type sbt parms
"SBT_LIBRARY=/orclhome/lib/libosbws11.so
ENV=(OSB_WS_PFILE=/orclhome/dbs/osbwst1.ora)';

using target database control file instead of recovery catalog
new RMAN configuration parameters:

"SBT_LIBRARY=/orclhome/lib/libosbws11.so
ENV=(OSB_WS_PFILE=/orclhome/dbs/osbwst1.ora)';
new RMAN configuration parameters are successfully stored
```

When this example completes, the system is configured for OSB Cloud Module backups and you can use your usual RMAN backup and restore commands.

**Note:** For 11g Release 2 databases and later, you must use the `SBT_PARMS` parameter to specify environment variables.

## F.2.8 Using the OSB Web Services Library and First Backup

After installing and configuring the Oracle Secure Backup Cloud Module, you are ready to connect to your target database and configure an RMAN channel.

You must specify both the library and the configuration file in the command.

The following example configures an RMAN channel for an Oracle 11g Release 2 database:

```
RMAN> run {
    allocate channel dev1 type
    sbt parms='SBT_LIBRARY=/orclhome/lib/libosbws11.so,
    SBT_PARMS=(OSB_WS_PFILE=/orclhome/dbs/osbwst1.ora)';
}
```

At this point, you can issue your usual RMAN backup and restore commands.

**Note:** For Oracle 11g Release 2 databases and later, you must use the `SBT_PARMS` parameter for specifying environment variables. For pre-Oracle 11g Release 2 databases, you can still use the `ENV` parameter of the `PARMS` option to specify environment variables.



### See Also:

*Database Backup in the Cloud* technical brief and the *Backup Database Demonstration* on the OTN: Cloud Computing Center website

## F.3 Securing OSB Cloud Module Backups

To ensure that your data is properly secured, Oracle recommends that you make RMAN backup encryption a standard part of your backup processes.

This recommendation is even more important to implement when you are storing critical backup data off-premises. Encrypting RMAN backups on Amazon S3 can also assist you in meeting key audit and regulatory compliance requirements for your organization's data.



### See Also:

"[Encryption of Backup Sets](#)" for a discussion of RMAN encryption options.

## F.4 Helpful Links: Oracle Secure Backup Cloud Module

For more information on Oracle Secure Backup Cloud Module, see the Frequently Asked Questions (FAQ) in My Oracle Support Note 740226.1 at <https://support.oracle.com/rs?type=doc&id=740226.1>

## F.5 Troubleshooting the OSB Cloud Module

This section lists potential issues that may affect the installation or the operation of the Oracle Secure Backup Cloud Module.

Symptoms	Error Messages	Resolution
The S3 Backup installation cannot create the license file on Amazon S3.	Time-out waiting for license file to be created.	The first time you run the S3 Backup installer for a set of AWS identifiers, the installer creates a license file on Amazon S3. If there are problems preventing its creation the time-out error message is displayed in the installation output.  Contact Oracle support to resolve the issue.



# Index

## Symbols

---

- ? symbol in quoted strings, [1-2](#)
- @ command, [2-2](#)
- @ symbol in quoted strings, [1-2](#)
- @@ command, [2-3](#)

## A

---

- Advanced Security Option, [2-15](#)
- ADVISE FAILURE command, [2-5](#)
- AL16UTF16 character set, CLOB storage, [2-101](#)
- ALL FOREIGN DATAFILES parameter, [foreignFileSpec](#), [4-22](#)
- ALL FOREIGN DATAFILES parameter, [foreignFileSpec](#) subclause, [4-22](#)
- ALLOCATE CHANNEL command, [2-8](#)
  - [allocOperandList](#) subclause, [4-2](#)
- ALLOCATE CHANNEL FOR MAINTENANCE command, [2-11](#)
  - shared server, [2-12](#)
- [allocOperandList](#) subclause
  - parameter descriptions, [4-2](#)
  - syntax diagram, [4-2](#)
- ALTER DATABASE BACKUP command (SQL), [2-39](#)
- analyzing RMAN repositories, [3-37](#)
- archived log backups, [2-182](#)
- archived log copies, [2-182](#)
- archived log failover, [2-38](#)
- archived logs
  - in backup sets, [2-182](#)
  - validation report, [3-127](#)
- archived redo files, optimization algorithms, [2-73](#)
- archived redo logs, [4-5](#)
  - backing up, [2-27](#), [2-38](#), [2-50](#), [4-34](#)
    - in CDBs, [2-27](#), [2-38](#)
  - cataloging in RMAN repository, [2-59](#)
  - deleting, [2-43](#), [2-86](#), [2-135](#)
  - deletion policies, [2-81](#)
  - excluding from backup, [2-36](#), [2-51](#)
  - foreign (LogMiner), [4-24](#)
  - image copies, [2-45](#)
  - limiting number of backups, [2-34](#)
  - missing or inaccessible, [3-2](#)
- archived redo logs (*continued*)
  - obsolete, [3-40](#)
  - recovering, [3-2](#)
  - report output, [3-37](#)
  - restoring, [3-48](#)
  - restoring a range, [3-61](#)
  - specifying a range, [4-5](#)
  - using for recovery (example), [3-21](#)
  - validating, [3-131](#)
- ARCHIVELOG BACKUP COPIES parameter
  - CONFIGURE command, [2-86](#)
- ARCHIVELOG mode, [2-15](#), [2-142](#), [2-167](#)
- ARCHIVELOG parameter
  - VALIDATE command, [3-131](#)
- archivelogRecordSpecifier subclause, [4-5](#), [4-24](#)
  - parameter descriptions, [4-5](#)
  - syntax diagram, [4-5](#)
- archlogRange subclause
  - parameter descriptions, [4-5](#)
  - syntax diagram, [4-5](#), [4-24](#)
- arguments to stored scripts, [2-119](#)
- at sign command (@), [2-2](#)
- atClause subclause
  - parameter descriptions, [3-37](#)
  - syntax diagram, [3-39](#)
- AUTOBACKUP parameter, RESTORE command, [3-66](#)
- autoBackupOptList subclause
  - parameter descriptions, [3-48](#)
  - syntax diagram, [3-55](#)
- autobackups
  - control files
    - in CDBs, [2-88](#)
- autobackups, control files, [2-89](#)
- Automated Diagnostic Repository, logging failures, [3-127](#)
- automated repair, [3-30](#)
- automatic diagnostic repository, [2-6](#)
  - changing logged failures, [2-64](#)
- Automatic Storage Management (ASM)
  - channel allocation, [2-8](#)
  - converting format to, [2-110](#)
  - converting format to (example), [2-113](#)
  - converting formats, [2-101](#)
  - disk groups, [3-50](#)

Automatic Storage Management (ASM) (*continued*)  
 duplicating databases, [2-142](#)  
 specifying disk groups, [2-90](#)  
 AUXILIARY CHANNEL parameter  
 SHOW command, [3-103](#)  
 auxiliary databases  
 connecting to, [2-97](#), [4-11](#)  
 initialization files, [2-152](#)  
 auxiliary instances, specifying channels, [2-91](#)  
 availability, changing status for backup or copy,  
[2-67](#), [2-68](#)

## B

BACKED UP parameter, maintQualifier  
 subclause, [4-34](#)

backing up, excluded files, [2-15](#)

backup clause

parameter descriptions, [2-27](#)  
 syntax diagram, [2-15](#)

BACKUP command, [2-15](#)

backup clause, [2-15](#), [2-27](#)

backupOperand subclause, [2-15](#)

backupSpec subclause, [2-15](#)

backupSpecOperand subclause, [2-15](#)

backupTypeSpec subclause, [2-15](#)

copyOfSpec subclause, [2-15](#), [2-25](#)

datafileCopySpec subclause, [2-15](#), [2-26](#)

duration subclause, [2-15](#), [2-26](#)

fileNameConversionSpec parameter, [4-17](#)

forRecoveryOfSpec subclause, [2-15](#), [2-26](#)

limiting processing time, [2-48](#)

notBackedUpSpec subclause, [2-15](#), [2-26](#)

skipSpec subclause, [2-15](#), [2-27](#)

backup commands, [3-85](#)

BACKUP COPIES parameter

SET command, [3-94](#)

SHOW command, [3-103](#)

backup levels, [2-15](#)

backup media, [2-15](#)

BACKUP OPTIMIZATION parameter

SHOW command, [3-103](#)

backup pieces

adding to repository, [2-59](#)

available information, [2-182](#)

cross-checking or deleting, [2-12](#)

definition, [2-44](#)

maximum size, [4-3](#)

obsolete, [3-37](#)

overriding default copies, [3-94](#)

restoring, [3-50](#)

backup sections, sizing, [2-35](#)

backup set failover, [2-39](#)

backup sets

about archived logs, [2-182](#)

backup sets (*continued*)

available information, [2-182](#)

backing up, [2-15](#)

backing up encrypted, [2-39](#)

backup pieces, available information, [2-182](#)

binary compression, [2-15](#), [2-45](#)

cataloging in RMAN repository, [2-59](#)

date ranges, [2-125](#)

deleting, [2-43](#), [2-135](#)

encryption, [2-15](#)

information about copies, [2-182](#)

information about data files, [2-182](#)

maximum size, [2-34](#)

obsolete

report output, [3-37](#)

optimization algorithms, [2-73](#)

status, [2-122](#)

summary information, [2-182](#)

tag names, [2-36](#)

unused block compression, [2-44](#)

BACKUP\_TAPE\_IO\_SLAVES initialization

parameter, [2-10](#), [2-86](#)

backupCommands subclause, syntax diagram,  
[3-85](#)

backupConf subclause

parameter descriptions, [2-73](#)

syntax diagram, [2-75](#)

backupOperand subclause

parameter descriptions, [2-15](#)

syntax diagram, [2-15](#)

backups

applying incremental, [3-2](#)

archive logs in CDBs, [2-27](#), [2-38](#)

binary compression, [2-15](#), [2-45](#)

CDBs, [2-15](#)

changing availability, [2-67](#), [2-68](#)

configuration, [2-73](#)

corruption tolerance (example), [2-55](#)

creating multiple copies, [2-86](#)

creating transportable tablespaces, [3-117](#)

criteria for obsolescence, [4-37](#)

cumulative, [2-15](#)

data files, [2-44](#)

deleting, [2-125](#)

duplexing example, [2-94](#)

duplicate copies, [2-10](#)

duplicating, [2-141](#)

for cross-platform transport, [2-15](#)

inconsistent, [2-15](#)

incremental, [2-15](#), [2-49](#)

limiting duration, [2-48](#)

listing, [2-182](#)

multisection, [2-35](#)

obsolete, [3-40](#)

overwriting, [2-35](#)

- backups (*continued*)
    - partial, [2-48](#)
    - PDBs, [2-15](#), [2-47](#)
    - redundant, [3-37](#)
    - restarting, [2-51](#)
    - retention policies, [2-85](#)
    - root, [2-15](#), [2-47](#)
    - tablespaces in CDBs, [2-42](#)
    - using incremental (example), [3-23](#)
    - using incremental updates (example), [3-22](#)
    - validating in repository, [2-121](#)
  - backupSpec subclause
    - parameter descriptions, [2-15](#)
    - syntax diagram, [2-15](#)
  - backupSpecOperand subclause
    - parameter descriptions, [2-15](#)
    - syntax diagram, [2-15](#)
  - backupTypeSpec subclause
    - parameter descriptions, [2-15](#)
    - syntax diagram, [2-15](#)
  - Backus Naur Form syntax diagrams, [1-1](#)
  - base recovery catalog, [2-115](#)
  - batch files, [2-2](#)
  - BFILE data type, excluded from backup, [2-15](#)
  - binary compression, [2-15](#), [2-45](#)
  - block change tracking files
    - excluded from backup, [2-15](#)
    - improving performance, [2-15](#)
  - block checksums, [2-34](#)
  - block corruptions
    - checking for, [3-128](#)
    - flashback, [2-169](#)
  - block media recovery, [3-2](#)
  - block sizes of backup media, [2-15](#)
  - blockObject subclause
    - parameter descriptions, [3-2](#)
    - syntax diagram, [3-7](#), [3-129](#)
  - blocks
    - corrupt, [3-127](#)
    - creating, [3-85](#)
  - BNF syntax diagrams, [1-1](#)
  - braces {}, [3-85](#)
- ## C
- 
- CATALOG command, [2-59](#)
  - CATALOG privilege, [2-116](#)
  - catalogs
    - importing, [2-179](#)
  - CDBs
    - backing up, [2-15](#)
      - as image copies, [2-47](#)
      - tablespaces, [2-42](#)
    - connecting to, [2-97](#), [4-11](#)
    - control file autobackups, [2-88](#)
  - CDBs (*continued*)
    - converting, [2-101](#)
    - deleting archived redo logs, [2-128](#)
    - duplicating, [2-146](#)
    - recovering, [3-2](#)
    - resetting the incarnation, [3-46](#)
    - restoring, [3-48](#)
    - transporting tablespaces, [2-108](#)
  - CDs as backup media, [2-15](#)
  - cfauConf subclause
    - parameter descriptions, [2-73](#)
    - syntax diagram, [2-76](#)
  - CHANGE command, [2-64](#)
    - changeFailure subclause, [2-64](#), [2-66](#)
    - forDbUniqueNameOption subclause, [2-66](#)
    - maintSpec subclause, [2-65](#), [4-35](#)
    - recordSpec subclause, [4-38](#)
    - resetDbUniqueNameOption subclause, [2-64](#), [2-66](#)
  - changeFailure subclause
    - parameter descriptions, [2-64](#)
    - syntax diagram, [2-66](#)
  - changes, reversing, [2-167](#)
  - channel names, [2-9](#)
  - CHANNEL parameter
    - SHOW command, [3-103](#)
  - channels
    - allocating manually, [2-8](#), [2-11](#)
    - allocating to shared server sessions, [2-12](#)
    - configuring for RAC (example), [2-95](#)
    - identifying database server sessions, [3-98](#)
    - maximum number, [2-8](#)
    - naming conventions, [2-90](#)
    - releasing, [3-27](#)
    - restoring in Data Guard, [3-64](#)
    - setting for restore (example), [3-21](#)
    - with proxy capabilities, [2-35](#)
  - character sets, CLOB storage, [2-101](#)
  - CHECK LOGICAL parameter
    - BACKUP command, [2-55](#)
  - checksums, [2-34](#)
  - clauses not compatible with, [2-15](#)
  - client compatibility, [D-1](#)
  - client, opening RMAN, [3-80](#)
  - CLOB data type, transporting, [2-101](#)
  - closing RMAN, [2-166](#), [2-206](#)
  - Cloud computing, [F-1](#)
  - cmdLine clause
    - parameter descriptions, [3-80](#)
    - syntax diagram, [3-80](#)
  - command examples commonly used, [B-1](#)
  - command files, [2-2](#), [2-3](#)
  - command format, [1-3](#)
  - COMMAND ID TO parameter
    - SET command, [3-98](#)

- command line arguments, [3-80](#)
- command subclause summary, [1-6](#)
- command summary, [1-4](#)
- command terminator, [1-3](#)
- commands
  - creating blocks, [3-85](#)
  - deprecated, [C-1](#)
  - executing host, [2-178](#)
  - executing SQL, [3-110](#)
  - RMAN, [3-80](#)
  - sending to media managers, [3-87](#)
- commands (
  - examples, [B-1](#)
  - samples, [B-1](#)
- commands(
  - commonly used, [B-1](#)
- comment character (#), [1-3](#)
- compatibility, [D-1](#)
- COMPATIBLE initialization parameter, [2-138](#)
- completedTimeSpec subclause, [4-10](#)
- compression, [2-45](#)
- COMPRESSION ALGORITHM parameter
  - HIGH, [2-79](#)
  - LOW, [2-79](#)
  - MEDIUM, [2-79](#)
- configuration
  - displaying, [2-73](#)
  - displaying settings, [3-101](#)
  - overriding, [3-85](#), [3-89](#)
  - restoring default settings, [2-74](#)
  - setting, [2-73](#)
- configuration files, excluded from backup, [2-15](#)
- configuration parameters
  - OSB Cloud Module, [F-2](#)
- CONFIGURE BACKUP OPTIMIZATION setting, [2-42](#)
- configure clause
  - parameter descriptions, [2-77](#)
  - syntax diagram, [2-75](#)
- CONFIGURE command, [2-73](#)
  - backupConf subclause, [2-73](#), [2-75](#)
  - cfauConf subclause, [2-73](#), [2-76](#)
  - configure clause, [2-75](#), [2-77](#)
  - delalConf subclause, [2-73](#), [2-75](#)
  - deviceConf subclause, [2-73](#), [2-76](#)
  - encryption settings, [2-15](#)
  - forDbUniqueNameOption subclause, [2-76](#)
- CONFIGURE commands, [3-101](#)
- CONFIGURE CONTROLFILE AUTOBACKUP
  - parameter, [2-40](#)
- CONNECT command, [2-97](#)
- connecting
  - to CDBs, [2-97](#), [4-11](#)
  - to PDBs, [2-97](#), [4-11](#), [4-13](#)
  - to root, [4-13](#)
- connections, changing, [2-98](#)
- connectStringSpec subclause, [4-11](#)
- consistent shutdowns, [2-15](#)
- control file copies
  - available information, [2-182](#)
  - tag names, [2-36](#)
- control files
  - automatic backups, [2-89](#)
  - backing up copies, [2-47](#)
  - copies
    - cataloging in RMAN repository, [2-59](#)
    - file names for control file autobackup, [3-98](#)
    - restoring, [3-48](#), [3-52](#)
    - restoring (example), [3-22](#)
    - restoring autobackups, [3-66](#)
    - restoring for primary database, [3-63](#)
    - resynchronization, [3-74](#)
    - snapshots, [2-43](#), [2-81](#)
    - validation report, [3-127](#)
- CONTROL\_FILES initialization parameter, [2-137](#)
- CONTROLFILE AUTOBACKUP FORMAT
  - parameter, SET command, [3-98](#)
- CONTROLFILE AUTOBACKUP parameter
  - SHOW command, [3-103](#)
- convert clause
  - parameter descriptions, [2-105](#)
  - syntax diagram, [2-101](#)
- CONVERT command
  - convert clause, [2-101](#), [2-105](#)
  - convertOptionList subclause, [2-101](#), [2-105](#)
  - fileNameConversionSpec parameter, [4-17](#)
  - formatSpec subclause, [2-105](#)
  - skipSpec subclause, [2-101](#), [2-104](#)
  - transportOptionList subclause, [2-101](#), [2-104](#)
- converting
  - CDBs, [2-101](#)
  - PDBs, [2-32](#), [2-37](#)
  - root, [2-106](#)
- convertOptionList subclause
  - parameter descriptions, [2-101](#)
  - syntax diagram, [2-105](#)
- copies
  - changing availability, [2-67](#), [2-68](#)
  - creating multiple backups, [2-86](#)
  - deleting, [2-125](#), [2-135](#)
  - of backup sets, available information, [2-182](#)
  - validating in repository, [2-121](#)
  - viewing status, [2-122](#)
- copy location, [2-45](#)
- COPY OF parameter
  - BACKUP command, [2-47](#)
- copying files, [2-45](#)
- copyOfSpec subclause
  - parameter descriptions, [2-15](#)
  - syntax diagram, [2-25](#), [3-127](#)

corrupt blocks  
 checking for, [3-127](#)  
 restoring, [3-50](#)  
 tolerance for (example), [2-55](#)  
 CORRUPTION LIST parameter, RECOVER  
 command, [3-14](#)  
 CPU\_COUNT initialization parameter, [3-19](#)  
 CREATE CATALOG command, [2-115](#)  
 CREATE SCRIPT command, [2-118](#)  
 CREATE TYPE privilege, [3-126](#)  
 cross-platform backup  
 export dump file, [2-41](#)  
 cross-platform compatibility, [2-15](#)  
 cross-platform transport  
 creating backups, [2-15](#)  
 CROSSCHECK command, [2-121](#)  
 maintSpec subclause, [2-121](#), [4-35](#)  
 recordSpec subclause, [4-38](#)  
 cumulative backups, [2-15](#)

## D

---

data blocks  
 checking for corrupted, [2-37](#)  
 recovering corrupt, [3-2](#)  
 recovering physically corrupt, [3-14](#)  
 data compression, [2-45](#)  
 data encryption, [2-138](#)  
 data file backup sets, available information,  
[2-182](#)  
 data file backups  
 available information, [2-182](#)  
 data file copies  
 available information, [2-182](#)  
 deleting, [2-43](#)  
 obsolete, [3-40](#)  
 report output, [3-37](#)  
 PDBs  
 listing, [3-42](#)  
 tag names, [2-36](#)  
 validating, [3-132](#)  
 data files  
 backing up, [2-15](#), [2-44](#)  
 backing up copies, [2-47](#)  
 backing up large, [2-35](#)  
 backing up new only, [2-50](#)  
 copies  
 cataloging in RMAN repository, [2-59](#)  
 incremental backups, [2-62](#)  
 tag names, [2-62](#)  
 excluding from backup, [2-36](#), [2-51](#)  
 excluding from conversion, [2-109](#)  
 flashback status changes, [2-169](#)  
 image copies, [2-45](#)

data files (*continued*)  
 in backup sets  
 available information, [2-182](#)  
 offline, [2-51](#)  
 optimization algorithms, [2-73](#)  
 readonly, [2-51](#)  
 recovering, [3-2](#)  
 recovering corrupt data blocks, [3-2](#)  
 renaming, [3-95](#), [3-96](#)  
 report output, [3-37](#)  
 requiring backup  
 report output, [3-37](#)  
 restored location, [3-50](#)  
 restoring, [3-48](#)  
 to new locations, [3-48](#)  
 restoring over the network, [3-53](#)  
 reversing changes, [2-167](#)  
 updating file names, [3-113](#)  
 validation report, [3-127](#)  
 Data Guard  
 changing backup associations, [2-69](#)  
 configuring databases, [2-74](#)  
 creating physical standby databases, [2-74](#)  
 creating standby databases (example), [2-162](#)  
 deleting backups and copies, [2-126](#)  
 restoring backups, [3-52](#)  
 RMAN configuration in recovery catalog,  
[2-81](#)  
 specifying databases, [4-19](#)  
 updating backup status, [2-123](#)  
 Data Guard backups  
 accessibility by databases, [2-15](#)  
 changing associated database, [2-64](#)  
 database association, [2-15](#)  
 Data Pump, [2-101](#), [2-170](#), [3-118](#), [D-3](#)  
 Data Recovery Advisor, [2-5](#), [3-30](#)  
 data types, endian conversion, [2-101](#)  
 database changes, reversing, [2-167](#)  
 database configuration, [3-101](#)  
 database duplication, [2-11](#)  
 database failure, repairing, [3-30](#)  
 database identifiers  
 changing, [2-15](#)  
 duplicates, [3-26](#)  
 database incarnations, [2-182](#)  
 DATABASE parameter, listObjList subclause,  
[4-31](#)  
 database point-in-time recovery (DBPITR), [3-2](#)  
 DATABASE ROOT parameter  
 REPORT command, [3-42](#)  
 RESTORE command, [3-48](#)  
 DATABASE ROOT parameter, dbObject  
 subclause, [4-16](#)  
 database schemas  
 report output, [3-37](#)

- database server sessions
  - identifying channels, [3-98](#)
- databases, [2-138](#)
  - available information, [2-182](#)
  - backing up, [2-15](#)
  - changing connections, [2-98](#)
  - connecting to, [2-97](#)
  - copying, [2-136](#)
  - deleting, [2-135](#)
  - platform conversion scripts, [2-109](#)
  - recovering, [3-2](#)
  - recovering with incremental backups (example), [3-23](#)
  - recovering with incremental updates, [3-22](#)
  - registering, [3-26](#)
  - removing from recovery catalog, [3-122](#)
  - resetting incarnation, [3-46](#)
  - resynchronization, [3-74](#)
  - shutting down target, [3-104](#)
  - specifying in Data Guard environment, [4-19](#)
  - starting target from RMAN, [3-111](#)
  - transparent encryption, [2-80](#)
  - transporting re-created files, [2-106](#)
  - updating file names, [3-113](#)
- DATAFILE BACKUP COPIES parameter
  - CONFIGURE command, [2-86](#)
  - SHOW command, [3-103](#)
- datafileCopySpec subclause
  - parameter descriptions, [2-15](#)
  - syntax diagram, [2-26](#)
- datafileSpec subclause, [4-14](#)
- DATAPUMP DIRECTORY parameter,
  - TRANSPORT TABLESPACE command, [3-120](#)
- date ranges of backup sets, [2-125](#)
- dates in RMAN commands, [4-43](#)
- DB\_BLOCK\_CHECKSUM initialization parameter, [2-34](#)
- DB\_CREATE\_FILE\_DEST initialization parameter, [4-3](#)
- DB\_FILE\_NAME\_CONVERT initialization parameter, [2-143](#), [2-150](#), [2-155](#), [3-119](#), [4-17](#)
- DB\_FLASHBACK\_RETENTION\_TARGET initialization parameter, [2-168](#)
- DB\_NAME, changing, [2-15](#)
- DB\_UNIQUE\_NAME initialization parameter, [3-66](#)
- DB\_UNIQUE\_NAME parameter
  - CONFIGURE command, [2-81](#)
  - DELETE command, [2-128](#)
- DB\_UNIQUE\_NAME setting, [2-61](#), [2-64](#), [2-182](#)
- DBIDs
  - available information, [2-201](#)
  - changing, [2-15](#)
- DBIDs (*continued*)
  - duplicates, [3-26](#)
  - of standby databases, [2-136](#)
- DBNEWID utility, [3-26](#)
- dbObject subclause
  - parameter descriptions, [4-15](#)
  - RECOVER command, [3-2](#)
- dbObject subclause diagram
  - RECOVER command, [3-6](#)
- DEFAULT DEVICE TYPE parameter
  - SHOW command, [3-103](#)
- delalConf subclause
  - command parameters, [2-73](#)
  - syntax diagram, [2-75](#)
- delete clause, syntax diagram, [2-125](#)
- DELETE command, [2-125](#)
  - delete clause, [2-125](#)
  - forDbUniqueNameOption subclause, [2-127](#)
  - maintSpec subclause, [2-127](#), [4-35](#)
  - recordSpec subclause, [4-38](#)
- DELETE SCRIPT command, [2-131](#)
- deleting
  - archived redo logs
    - in CDBs, [2-128](#)
- deprecated commands, [C-1](#)
- destinations for restoring data files, [3-48](#)
- DEVICE TYPE parameter
  - maintSpec subclause, [4-36](#)
  - SEND command, [3-88](#)
  - SHOW command, [3-103](#)
- device types, specifying, [2-91](#)
- deviceConf subclause
  - parameter descriptions, [2-73](#)
  - syntax diagram, [2-76](#)
- deviceSpecifier subclause, [4-16](#)
- diagnostic repository, [2-6](#)
- diagrams of syntax, [1-1](#)
- disk drives, using several for backup, [2-10](#)
- disk files, creating from stored scripts, [2-204](#)
- displaying scripts, [2-204](#)
- double at sign command (@@), [2-3](#)
- double quotes, [1-3](#)
- DROP CATALOG command, [2-134](#)
- DROP DATABASE command, [2-135](#)
- dual-mode encryption, [2-15](#)
- DUMP FILE parameter, foreignFileSpec, [4-22](#)
- DUMP FILE parameter, foreignFileSpec subclause, [4-22](#)
- duplexing, [2-86](#), [2-94](#), [3-94](#)
- duplicate clause
  - parameter descriptions, [2-136](#)
  - syntax diagram, [2-143](#)
- DUPLICATE command, [2-136](#)
  - duplicate clause, [2-136](#), [2-143](#)
  - dupOptionList subclause, [2-136](#), [2-144](#)

DUPLICATE command (*continued*)  
 fileNameConversionSpec parameter, [4-17](#)  
 logSpec subclause, [2-136](#), [2-146](#)  
 setParameter subclause, [2-136](#), [2-146](#)

duplicate databases  
 using CONFIGURE AUXNAME, [2-161](#)

duplicating  
 CDBs, [2-146](#)

duplicating files, [2-45](#)

duplication  
 backup based, [2-142](#)  
 configuration, [2-73](#)  
 example using auxiliary channels, [2-11](#)

dupOptionList subclause  
 parameter descriptions, [2-136](#)  
 syntax diagram, [2-144](#)

duration subclause  
 parameter descriptions, [2-15](#)  
 syntax diagram, [2-26](#)

DVDs as backup media, [2-15](#)

dynamic performance views  
 summary list, [5-1](#)  
 V\$DATABASE\_BLOCK\_CORRUPTION,  
[2-37](#), [3-3](#), [3-14](#), [3-128](#)  
 V\$DATABASE\_FLASHBACK\_ON, [2-168](#)  
 V\$DATABASE.CURRENT\_SCN, [2-168](#)  
 V\$FLASHBACK\_DATABASE\_LOG, [2-172](#)  
 V\$RMAN\_COMPRESSION\_ALGORITHM,  
[2-79](#), [3-91](#)  
 V\$RMAN\_ENCRYPTION\_ALGORITHMS,  
[2-15](#), [2-80](#), [3-92](#)  
 V\$RMAN\_OUTPUT, [2-15](#), [3-82](#)  
 V\$RMAN\_STATUS, [3-82](#)  
 V\$SESSION, [3-98](#)  
 V\$TABLESPACE, [2-170](#)  
 V\$TRANSPORTABLE\_PLATFORM, [2-101](#)

## E

---

encryption  
 backup sets, [2-15](#), [2-39](#), [3-48](#)  
 of duplicate databases, [2-138](#)  
 recovering tablespaces, [3-2](#)

ENCRYPTION ALGORITHM parameter,  
 CONFIGURATION command, [2-80](#)

encryption algorithms, [2-15](#)

encryption settings  
 overriding, [2-80](#)  
 V\$RMAN\_ENCRYPTION\_ALGORITHMS  
 view, [2-80](#)

end times  
 for restore, [3-98](#)

endian formats  
 converting, [2-101](#)  
 transportable tablespaces, [3-117](#)

endian formats (*continued*)  
 transporting across platforms, [2-101](#)

environment variables  
 in RMAN strings, [1-2](#)  
 NLS\_DATE\_FORMAT, [3-42](#)  
 NLS\_LANG, [3-42](#)

error messages  
 ORA-1152, [2-149](#)  
 ORA-1578, [3-14](#)  
 ORA-19504, [2-151](#)  
 ORA-19624, [2-151](#)  
 ORA-19916, [2-19](#)  
 ORA-27086, [2-151](#)  
 RMAN-0558, [3-81](#)  
 RMAN-06004, [2-165](#)  
 RMAN-06445, [2-99](#), [2-100](#)  
 RMAN-06496, [3-51](#), [3-52](#)  
 RMAN-10031, [2-151](#)  
 RMAN-10035, [2-151](#)  
 RMAN-6758, [3-64](#)  
 too many open files, [4-3](#)

EXECUTE SCRIPT command, [2-164](#)

EXIT command, [2-166](#)

exiting RMAN, [2-206](#)

EXPORT LOG parameter, TRANSPORT  
 TABLESPACE command, [3-120](#)

export utilities, [2-101](#)

external tables, excluded from backup, [2-15](#)

## F

---

failed backups, restarting, [2-51](#)

failure summary, [2-5](#)

failures, available information, [2-182](#)

fast recovery, [2-42](#)

fast recovery areas  
 defining for duplicate databases, [2-142](#)  
 location of autobackup, [2-90](#)

file copies, [2-45](#)

file name formats, [3-98](#)

file names  
 changing during platform conversion, [2-110](#)  
 data file image copies, [2-41](#)  
 generating new, [4-17](#)  
 updating, [3-113](#)

file sections, sizing, [2-35](#)

fileNameConversionSpec subclause, [4-17](#)

files  
 backing up new only, [2-50](#)  
 backing up with proxy copy, [2-35](#)  
 changing availability, [2-67](#), [2-68](#)  
 creating from stored scripts, [2-204](#)  
 excluded from backup, [2-15](#)  
 listing those needing backup, [3-39](#)  
 naming backups, [2-36](#)

files (*continued*)  
 overwriting backups, [2-35](#)  
 sources for duplication, [2-141](#)  
 unavailable, [2-68](#)  
 validating, [2-37](#)

FLASHBACK DATABASE command, [2-167](#)

flashback logs, [2-168](#), [3-48](#)

flashback NOLOGGING operations, [2-169](#)

FOR TRANSPORT  
 clauses not compatible with, [2-15](#)

forDbUniqueNameOption subclause  
 parameter descriptions, [4-19](#)  
 syntax, [4-19](#)  
 syntax diagram, [2-66](#), [2-76](#), [2-127](#)

foreignFileSpec, [4-20](#)

foreignFileSpec subclause, [4-20](#)

foreignlogRecordSpecifier subclause  
 syntax diagram, [4-24](#)

formatSpec subclause, syntax diagram, [2-105](#)

forRecoveryOfSpec subclause  
 parameter descriptions, [2-15](#)  
 syntax diagram, [2-26](#)

FROM AUTOBACKUP parameter, RESTORE  
 command, [3-66](#)

FTP, moving backups, [2-15](#)

## G

---

global scripts  
 executing, [2-164](#)  
 importing, [2-180](#)  
 printing, [2-204](#)

GRANT command, [2-175](#)

## H

---

hardware error recovery (example), [3-21](#)

HOST command, [2-178](#)

## I

---

image copies  
 adding to repository, [2-59](#)  
 applying incremental backups, [3-2](#)  
 backing up, [2-47](#)  
 in CDBs, [2-47](#)  
 creating, [2-45](#)  
 deleting, [2-135](#)  
 restoring, [3-50](#)

IMPORT CATALOG command, [2-179](#)

IMPORT SCRIPT parameter, TRANSPORT  
 TABLESPACE command, [3-120](#)

import utilities, [2-101](#)

INCARNATION parameter  
 DUPLICATE command  
 orphan, [2-147](#)  
 RESET DATABASE TO INCARNATION, [3-46](#)  
 SET command, [3-99](#)

incarnations, [2-182](#), [3-46](#)

inconsistent backups, [2-15](#)

inconsistent shutdowns, [2-15](#)

incremental backups, [2-15](#), [2-49](#)  
 adding data file copies, [2-62](#)  
 bitmap limit, [2-15](#)  
 report output, [3-37](#)  
 sample script, [2-53](#)  
 using data file copy, [2-59](#)

initialization files  
 for auxiliary databases, [2-152](#)

initialization parameters  
 BACKUP\_TAPE\_IO\_SLAVES, [2-86](#)  
 COMPATIBLE, [2-138](#)  
 CONTROL\_FILES, [2-137](#)  
 CPU\_COUNT, [3-19](#)  
 DB\_BLOCK\_CHECKSUM, [2-34](#)  
 DB\_CREATE\_FILE\_DEST, [4-3](#)  
 DB\_FILE\_NAME\_CONVERT, [2-143](#), [2-150](#),  
[3-119](#), [4-17](#)  
 DB\_FLASHBACK\_RETENTION\_TARGET,  
[2-168](#)  
 DB\_UNIQUE\_NAME, [3-66](#)  
 LOG\_ARCHIVE\_DEST\_n, [3-94](#)  
 LOG\_FILE\_NAME\_CONVERT, [2-143](#), [3-119](#)  
 RECOVERY\_PARALLELISM, [3-19](#)

input files, deleting, [2-43](#)

## J

---

job commands, [3-85](#)

## K

---

KEEP parameter  
 BACKUP command, [2-33](#)

keepOption subclause, [4-28](#)

keystore-based encryption, [2-15](#)

keystores, [2-138](#), [3-118](#)

keywords in syntax diagrams, [1-2](#)

## L

---

LIKE parameter  
 archivelogRecordSpecifier subclause, [4-5](#)

Linux commands, [2-178](#)

Linux-to-Windows conversion (example), [2-114](#)

list clause  
 parameter descriptions, [2-182](#)



list clause (*continued*)  
 syntax diagram, [2-183](#)

LIST command, [2-182](#)  
 list clause, [2-182](#), [2-183](#)  
 listBackupOption subclause, [2-182](#), [2-185](#)  
 listObjectSpec subclause, [2-182](#), [2-184](#)  
 maintQualifier subclause, [2-184](#)  
 recordSpec subclause, [4-38](#)  
 recoverableClause subclause, [2-182](#), [2-185](#)

listBackupOption subclause  
 parameter descriptions, [2-182](#)  
 syntax diagram, [2-185](#)

listObjectSpec subclause  
 parameter descriptions, [2-182](#)  
 syntax diagram, [2-184](#)

listObjList subclause, [4-30](#)  
 parameter descriptions, [4-30](#)  
 syntax diagram, [4-31](#)

LOB data types, transporting, [2-101](#)

local scripts  
 executing, [2-164](#)  
 printing, [2-204](#)

log files  
 directing output to, [3-106](#)

log sequence number, [3-98](#)

log sequence numbers  
 point-in-time recovery, [2-154](#)  
 undoing changes, [2-167](#)

LOG\_ARCHIVE\_DEST\_n initialization  
 parameter, [3-4](#), [3-94](#)

LOG\_FILE\_NAME\_CONVERT initialization  
 parameter, [2-143](#), [3-119](#)

logging in, [4-11](#)

LogMiner utility, [2-67](#), [2-82](#), [4-24](#)

logSpec subclause  
 parameter descriptions, [2-136](#)  
 syntax diagram, [2-146](#)

## M

---

maintenance channels  
 allocating, [2-11](#)  
 naming conventions, [2-12](#)  
 releasing, [3-27](#)

maintenance commands, [3-85](#)

maintenance job configuration, [2-73](#)

maintenanceCommands subclause, syntax  
 diagram, [3-85](#)

maintQualifier subclause  
 parameter descriptions, [4-33](#)  
 syntax diagram, [2-184](#), [4-33](#)

maintSpec subclause, [4-35](#)  
 syntax diagram, [2-65](#), [2-121](#), [2-127](#)

media failure, restoring backups, [3-48](#)

media libraries for sbt channels, [4-4](#)

media managers, [2-44](#)  
 compressing data, [2-45](#)  
 controlling data transfer, [2-35](#)  
 sending commands, [3-87](#)  
 specifying environment variables, [4-4](#)  
 status of offsite backups, [3-59](#)  
 validating metadata, [2-123](#)

media pool, backup storage, [2-35](#)

metadata  
 changing catalog schemas, [2-179](#)  
 resynchronization, [3-74](#)  
 validating in repository, [2-121](#)

miscellaneous commands, [3-85](#)

missing files  
 checking for, [3-127](#)

moving backups, [2-15](#)

multisection backups, [2-35](#)

multitenant container databases, [2-15](#)

## N

---

needBackupOption subclause  
 parameter descriptions, [3-37](#)  
 syntax diagram, [3-38](#)

nested command files, [2-3](#)

net service names, [4-11](#)

new files, backing up only, [2-50](#)

NEWNAME FOR DATABASE parameter, SET  
 command, [3-95](#)

NEWNAME FOR DATAFILE parameter, SET  
 command, [3-96](#)

NEWNAME FOR TABLESPACE parameter, SET  
 command, [3-96](#)

NEWNAME FOR TEMPFILE parameter, SET  
 command, [3-96](#)

NLS\_DATE\_FORMAT configuration setting,  
[2-191](#)

NLS\_DATE\_FORMAT environment variable, [3-42](#)

NLS\_LANG environment variable, [3-42](#)

NLS\_LANG environment variables, [2-191](#)

NOARCHIVELOG mode, [2-15](#), [2-142](#)

NOFILENAMECHECK parameter, DUPLICATE  
 command, [2-155](#)

nonquoted strings, [1-2](#)

NOREDO parameter  
 DUPLICATE command, [2-154](#)

normal resynchronization, [3-76](#)

notBackedUpSpec subclause  
 parameter descriptions, [2-15](#)  
 syntax diagram, [2-26](#)

## O

---

obsOperandList subclause, [4-37](#)

offsite backups, [3-59](#)

- OMF format, [2-143](#)
  - online redo logs
    - for duplicate database, [2-155](#)
    - for RAC, [2-150](#)
  - operating system commands, [2-178](#)
  - operating systems
    - compatibility, [2-15](#)
    - duplicating databases across, [2-137](#)
  - optimization algorithms, [2-73](#)
  - optimization, overriding backup, [2-86](#)
  - ORA-1152 error message, [2-149](#)
  - ORA-1578 error message, [3-14](#)
  - ORA-19504 error message, [2-151](#)
  - ORA-19624 error message, [2-151](#)
  - ORA-19916 error message, [2-19](#)
  - ORA-27086 error message, [2-151](#)
  - Oracle home, excluded from backup, [2-15](#)
  - Oracle keystores, [3-49](#), [3-118](#)
  - Oracle Managed Files (OMF), [2-143](#), [4-18](#)
    - duplicating databases (example), [2-162](#)
  - Oracle Net connections, [3-76](#)
  - Oracle RAC
    - recovering from failure, [3-31](#)
  - Oracle Secure Backup, [2-44](#)
    - creating encrypted backups, [2-15](#)
    - sending commands to (example), [3-88](#)
    - undo data, [2-86](#)
  - Oracle Secure Backup (OSB) Cloud Module
    - configuring RMAN channel, [F-11](#)
    - creating an AWS account, [F-5](#)
    - environment variables
      - ENV parameter of PARMS option, [F-11](#)
      - SBT\_PARMS parameter, [F-11](#)
    - getting AWS Identifiers, [F-6](#)
    - prerequisites, [F-4](#)
    - registering for OTN account, [F-5](#)
    - running the S3 Backup installer
      - first time, [F-6](#)
      - Linux example, [F-9](#)
    - Securing backups, [F-12](#)
    - storing configuration in RMAN repository, [F-11](#)
    - Troubleshooting, [F-12](#)
  - Oracle10g compatibility, [D-1](#)
  - Oracle8i compatibility, [D-1](#)
  - Oracle9i compatibility, [D-1](#)
  - overwriting backup files, [2-35](#)
- ## P
- 
- parallelism
    - allocating channels, [2-8](#)
    - backup using channels (example), [2-54](#)
    - channel allocation, [2-8](#)
  - parallelism settings, [3-103](#)
  - parameter files, [3-64](#)
    - backing up, [2-15](#), [2-42](#)
    - restoring, [3-52](#)
  - PARAMETER\_VALUE\_CONVERT parameter
    - overriding, [2-155](#)
  - parameters
    - deprecated, [C-1](#)
    - in syntax diagrams, [1-2](#)
  - parameters in stored scripts, [2-119](#)
  - partial backups, [2-48](#)
  - password encryption, [2-80](#)
  - password files
    - excluded from backup, [2-15](#)
    - for duplicate databases, [2-140](#)
  - password-based encryption, [2-15](#)
  - passwords, [4-11](#)
    - encrypted, [2-80](#)
    - encrypted backup sets, [3-50](#)
    - RAC SYSBACKUP, [2-9](#)
  - PDBs
    - backing up, [2-15](#), [2-47](#)
    - connecting to, [2-97](#), [4-11](#), [4-13](#)
    - converting, [2-32](#), [2-37](#)
    - listing backups, [3-42](#)
    - recovering, [3-2](#)
    - recovering tables, [3-11](#)
    - restoring, [3-48](#)
  - performance
    - allocating channels, [2-8](#)
    - incremental backups, [2-15](#)
  - PL/SQL code, converting formats, [2-137](#)
  - PL/SQL stored procedures, [3-110](#)
  - placeholders in syntax diagrams, [1-2](#)
  - platform compatibility, [2-15](#)
  - platforms
    - duplicating databases across, [2-137](#)
  - PLUGGABLE DATABASE parameter
    - REPORT command, [3-42](#)
  - pluggable databases, [2-15](#)
  - PLUS ARCHIVELOG parameter, VALIDATE
    - command, [3-131](#)
  - point-in-time recovery, [2-154](#), [3-2](#), [3-48](#), [4-9](#)
  - prerequisites
    - backups for cross-platform transport, [2-15](#)
    - cross-platform backups, [2-15](#)
  - previewing backups, [3-48](#)
  - primary databases
    - backing up, [2-15](#)
    - copying, [2-136](#)
  - PRINT SCRIPT command, [2-204](#)
  - private catalog schema, assigning privileges, [2-175](#)
  - privileges
    - assigning, [2-175](#)
    - CATALOG, [2-116](#)

privileges (*continued*)  
 CREATE TYPE, [3-126](#)  
 REGISTER, [2-116](#)  
 revoking, [3-78](#)  
 SYSBACKUP, [2-97](#)

processing time for backup, [2-48](#)

proxy backups, restoring, [3-3](#)

proxy copies  
 available information, [2-182](#)  
 cross-checking, [2-12](#)  
 definition, [2-44](#)  
 deleting, [2-12](#), [2-135](#)  
 obsolete  
   report output, [3-37](#)  
 restoring, [3-50](#)  
 tag names, [2-36](#)

## Q

---

QUIT command, [2-206](#)  
 quoted strings, [1-2](#)  
 QUOTEDSQLCOMMAND command, [3-110](#)

## R

---

### RAC

automatic channels (example), [2-95](#)  
 creating online redo logs, [2-150](#)  
 cross-checking or deleting, [2-12](#)  
 crosschecking backups, [2-14](#)  
 SYSBACKUP passwords, [2-9](#)

RC\_ARCHIVED\_LOG view, [5-4](#)

RC\_BACKUP\_ARCHIVELOG\_DETAILS view, [5-6](#)

RC\_BACKUP\_ARCHIVELOG\_SUMMARY view, [5-8](#)

RC\_BACKUP\_CONTROLFILE view, [5-9](#)

RC\_BACKUP\_CONTROLFILE\_DETAILS view, [5-10](#)

RC\_BACKUP\_CONTROLFILE\_SUMMARY view, [5-11](#)

RC\_BACKUP\_COPY\_DETAILS view, [5-12](#)

RC\_BACKUP\_COPY\_SUMMARY view, [5-14](#)

RC\_BACKUP\_CORRUPTION view, [5-14](#)

RC\_BACKUP\_DATAFILE view, [5-16](#)

RC\_BACKUP\_DATAFILE\_DETAILS view, [5-19](#)

RC\_BACKUP\_DATAFILE\_SUMMARY view, [5-20](#)

RC\_BACKUP\_FILES view, [5-21](#)

RC\_BACKUP\_PIECE view, [5-25](#)

RC\_BACKUP\_PIECE\_DETAILS, [5-27](#)

RC\_BACKUP\_REDOLOG view, [5-30](#)

RC\_BACKUP\_SET view, [5-31](#)

RC\_BACKUP\_SET\_DETAILS view, [5-34](#)

RC\_BACKUP\_SET\_SUMMARY view, [5-36](#)

RC\_BACKUP\_SPFILE view, [5-37](#)

RC\_BACKUP\_SPFILE\_DETAILS view, [5-38](#)

RC\_BACKUP\_SPFILE\_SUMMARY view, [5-39](#)

RC\_CHECKPOINT view, [5-39](#)

RC\_CONTROLFILE\_COPY view, [5-39](#)

RC\_COPY\_CORRUPTION view, [5-41](#)

RC\_DATABASE view, [5-42](#)

RC\_DATABASE\_BLOCK\_CORRUPTION view, [5-43](#)

RC\_DATABASE\_INCARNATION view, [5-44](#)

RC\_DATAFILE view, [5-45](#)

RC\_DATAFILE\_COPY view, [5-48](#)

RC\_DISK\_RESTORE\_RANGE view, [5-51](#)

RC\_LOG\_HISTORY view, [5-51](#)

RC\_OFFLINE\_RANGE view, [5-52](#)

RC\_PDBS view, [5-53](#)

RC\_PLUGGABLE\_DATABASE\_INC view, [5-53](#)

RC\_PROXY\_ARCHIVEDLOG view, [5-55](#)

RC\_PROXY\_ARCHIVELOG\_DETAILS view, [5-57](#)

RC\_PROXY\_CONTROLFILE view, [5-58](#)

RC\_PROXY\_COPY\_DETAILS view, [5-60](#)

RC\_PROXY\_COPY\_SUMMARY view, [5-62](#)

RC\_PROXY\_DATAFILE view, [5-63](#)

RC\_REDO\_LOG view, [5-65](#)

RC\_REDO\_THREAD view, [5-66](#)

RC\_RESTORE\_POINT view, [5-67](#)

RC\_RESTORE\_RANGE view, [5-67](#)

RC\_RESYNC view, [5-68](#)

RC\_RMAN\_BACKUP\_JOB\_DETAILS view, [5-69](#)

RC\_RMAN\_BACKUP\_SUBJOB\_DETAILS view, [5-71](#)

RC\_RMAN\_BACKUP\_TYPE view, [5-72](#)

RC\_RMAN\_CONFIGURATION view, [5-72](#)

RC\_RMAN\_OUTPUT view, [5-73](#)

RC\_RMAN\_STATUS view, [5-74](#)

RC\_SBT\_RESTORE\_RANGE view, [5-76](#)

RC\_SITE view, [5-77](#)

RC\_STORED\_SCRIPT view, [5-77](#)

RC\_STORED\_SCRIPT\_LINE view, [5-78](#)

RC\_TABLESPACE view, [5-78](#)

RC\_TEMPFILE view, [5-80](#)

RC\_UNUSABLE\_BACKUPFILE\_DETAILS view, [5-82](#)

Real Application Clusters, [2-14](#)

recordSpec subclause, [4-38](#)

recover clause  
   parameter descriptions, [3-2](#)  
   syntax diagram, [3-6](#)

RECOVER command, [3-2](#)  
   blockObject subclause, [3-2](#), [3-7](#)  
   dbObject subclause, [3-2](#)  
   recover clause, [3-2](#), [3-6](#)  
   recoverObject subclause, [3-2](#), [3-6](#)  
   recoverOptionList subclause, [3-2](#), [3-7](#)  
   recoverSpec subclause, [3-2](#), [3-6](#)

- recoverableClause subclause
  - parameter descriptions, [2-182](#)
  - syntax diagram, [2-185](#)
- recovering
  - PDBs, [3-2](#)
  - root, [3-2](#)
- recoverObject subclause
  - parameter descriptions, [3-2](#)
  - syntax diagram, [3-6](#)
- recoverOptionList subclause
  - parameter descriptions, [3-2](#)
  - syntax diagram, [3-7](#)
- recoverSpec subclause
  - parameter descriptions, [3-2](#)
  - syntax diagram, [3-6](#)
- recovery
  - CDBs, [3-2](#)
  - database in NOARCHIVELOG mode (example), [3-23](#)
  - PDBs, [3-2](#)
  - point-in-time of duplicate databases, [2-154](#)
  - search order for backups, [3-4](#)
  - using storage snapshots, [3-4](#)
- recovery catalog
  - connecting to, [4-11](#)
  - registering databases, [3-26](#)
  - removing databases, [3-122](#)
  - removing references, [2-68](#)
  - removing repository records, [2-125](#)
  - replacing scripts, [3-34](#)
  - updating DB\_UNIQUE\_NAME, [2-64](#)
  - upgrading versions, [3-125](#)
- recovery catalog databases, connecting to, [2-97](#)
- recovery catalog views, [5-1](#)
  - summary list, [5-1](#)
- recovery catalogs
  - creating, [2-115](#)
  - creating stored scripts, [2-118](#)
  - deleting, [2-134](#)
  - resynchronization, [3-74](#)
  - revoking privileges, [3-78](#)
  - stored scripts, available information, [2-182](#)
  - unregistering, [2-135](#)
- recovery catalogs, moving metadata, [2-179](#)
- recovery catalogs.NOCATALOG mode, [2-15](#)
- recovery files, backing up, [2-42](#)
- Recovery Manager
  - compatibility, [D-1](#)
  - dates in commands, [4-43](#)
- Recovery Manager client, opening, [3-80](#)
- Recovery Manager, control file autobackups, [2-89](#)
- recovery windows
  - report output, [3-37](#)
- recovery windows, report output, [3-37](#)
- RECOVERY\_CATALOG\_OWNER role, [3-126](#)
- RECOVERY\_PARALLELISM initialization
  - parameter, [3-19](#)
- redo logs
  - backing up, [2-15](#)
  - for RAC, [2-150](#)
- redo threads, [4-43](#)
- redundant backups, [3-37](#)
- REGISTER DATABASE command, [3-26](#)
- REGISTER privilege, [2-116](#)
- RELEASE CHANNEL command, [3-27](#)
  - release clause, [3-27](#)
  - releaseForMaint clause, [3-27](#)
- release clause, syntax diagram, [3-27](#)
- releaseForMaint clause
  - syntax diagram, [3-27](#)
- remote host
  - restoring data files, [3-53](#)
- repair clause
  - parameter description, [3-30](#)
  - syntax diagram, [3-31](#)
- REPAIR FAILURE command, [3-30](#)
  - repair clause, [3-30](#), [3-31](#)
- repair options, [2-5](#)
- repair status, [2-200](#)
- repair strategies, [2-5](#)
- REPLACE SCRIPT command, [3-34](#)
  - replaceScript clause, [3-34](#)
- replaceScript clause
  - syntax diagram, [3-34](#)
- report clause
  - parameter descriptions, [3-37](#)
  - syntax diagram, [3-38](#)
- REPORT command, [3-37](#)
  - atClause subclause, [3-37](#), [3-39](#)
  - needBackupOption subclause, [3-37](#), [3-38](#)
  - report clause, [3-37](#), [3-38](#)
  - reportObject subclause, [3-37](#), [3-38](#)
- reportObject subclause
  - parameter descriptions, [3-37](#)
  - syntax diagram, [3-38](#)
- repositories
  - analyzing, [3-37](#)
  - listing contents, [2-182](#)
  - updating, [2-125](#)
  - updating availability status, [2-64](#)
  - updating file names, [3-113](#)
  - validating contents, [2-121](#)
- reserved words, [1-3](#), [A-1](#)
- reset clause, syntax diagram, [3-46](#)
- RESET DATABASE command, [3-46](#)
  - reset clause, [3-46](#)
- resetDbUniqueNameOption subclause
  - parameter descriptions, [2-64](#)
  - syntax diagram, [2-66](#)

resetting incarnations  
     CDBs, [3-46](#)  
 restoration configuration, [2-73](#)  
 restore clause  
     parameter descriptions, [3-48](#)  
     syntax diagram, [3-53](#)  
 RESTORE command, [3-48](#)  
     autoBackupOptList subclause, [3-48](#), [3-55](#)  
     restore clause, [3-48](#), [3-53](#)  
     restoreObject subclause, [3-48](#), [3-54](#)  
     restoreSpecOperand subclause, [3-55](#)  
 restore commands, [3-85](#)  
 restore failover, [3-50](#)  
 RESTORE POINT parameter  
     RECOVER command, [3-11](#)  
     SET command, [3-98](#)  
     TRANSPORT TABLESPACE command,  
         [3-120](#)  
 restore points, [2-44](#), [2-182](#)  
 restoreCommands subclause, syntax diagram,  
     [3-85](#)  
 restoreObject subclause  
     parameter descriptions, [3-48](#)  
     syntax diagram, [3-54](#)  
 restoreSpecOperand subclause, syntax diagram,  
     [3-55](#)  
 restoring  
     CDBs, [3-48](#)  
     data files over the network, [3-53](#)  
     from remote hosts, [3-53](#)  
     PDBs, [3-48](#)  
     root, [3-48](#)  
 RESTRICTED SESSION privilege, [3-112](#)  
 RESYNC CATALOG command, [3-74](#)  
 RESYNC CATALOG, resync clause, [3-74](#)  
 resync clause, syntax diagram, [3-74](#)  
 resynchronization, [3-76](#)  
 retention policies, [4-28](#)  
     exemptions (example), [2-55](#)  
     overriding, [2-33](#), [2-67](#)  
 RETENTION POLICY parameter  
     SHOW command, [3-103](#)  
 reverse resynchronization, [3-76](#)  
 revoke clause, syntax diagram, [3-78](#)  
 REVOKE command, [3-78](#)  
     revoke clause, [3-78](#)  
 RMAN command, [3-80](#)  
     cmdLine clause, [3-80](#)  
 RMAN command (operating system), [3-80](#)  
 RMAN reserved words, [A-1](#)  
 RMAN-0558 error message, [3-81](#)  
 RMAN-06004 error message, [2-165](#)  
 RMAN-06445 error message, [2-99](#), [2-100](#)  
 RMAN-06496 error message, [3-51](#), [3-52](#)  
 RMAN-10031 error message, [2-151](#)

RMAN-10035 error message, [2-151](#)  
 RMAN-6758 error message, [3-64](#)  
 roles  
     RECOVERY\_CATALOG\_OWNER, [3-126](#)  
 rollback segments, resynchronization, [3-74](#)  
 root  
     backing up, [2-15](#), [2-47](#)  
     connecting to, [4-13](#)  
     converting, [2-106](#)  
     listing backups, [3-42](#)  
     listing data file copies, [3-42](#)  
     recovering, [3-2](#)  
     restoring, [3-48](#)  
 run clause, syntax diagram, [3-85](#)  
 RUN command, [3-85](#)  
     backupCommands subclause, [3-85](#)  
     maintenanceCommands subclause, [3-85](#)  
     restoreCommands subclause, [3-85](#)  
     run clause, [3-85](#)

## S

saving scripts, [2-204](#)  
 SCN  
     for restore, [3-98](#)  
     setting restore point, [3-98](#)  
 scopes, creating for scripts, [3-85](#)  
 scripts, [2-2](#)  
     available information, [2-182](#)  
     creating in recovery catalog, [2-118](#)  
     printing, [2-204](#)  
     replacing, [3-34](#)  
     substitution variables, [2-119](#)  
 Secure Backup, [2-15](#)  
 SEND command, [3-87](#)  
 SEQUENCE BETWEEN parameter,  
     archlogRange subclause, [4-8](#)  
 server parameter files, [3-64](#)  
     backing up, [2-15](#), [2-42](#)  
     for auxiliary databases, [2-152](#)  
     restoring, [3-52](#)  
     restoring lost, [3-112](#)  
     validation report, [3-127](#)  
 sessions  
     ending RMAN, [2-166](#)  
     identifying channels, [3-98](#)  
 set clause, syntax diagram, [3-89](#)  
 SET command, [3-89](#)  
     encryption settings, [2-15](#)  
     set clause, [3-89](#)  
     setRmanOption subclause, [3-89](#)  
     setRmanOrRunOption subclause, [3-89](#), [3-90](#)  
     setRunOption subclause, [3-89](#), [3-90](#)  
 SET MAXCORRUPT command, [2-55](#)  
 SET NEWNAME command, [3-48](#)

- setParameter subclause
    - parameter descriptions, [2-136](#)
    - syntax diagram, [2-146](#)
  - setRmanOption subclause
    - parameter descriptions, [3-89](#)
    - syntax diagram, [3-89](#)
  - setRmanOrRunOption subclause
    - parameter descriptions, [3-89](#)
    - syntax diagram, [3-90](#)
  - setRunOption subclause
    - parameter descriptions, [3-89](#)
    - syntax diagram, [3-90](#)
  - shared servers, allocating channels, [2-12](#)
  - shell commands, [2-178](#)
  - show clause, syntax diagram, [3-101](#)
  - SHOW command, [3-101](#)
    - show clause, [3-101](#)
  - SHUTDOWN command, [3-104](#)
  - shutdowns, [2-15](#)
  - single quotes, [1-3](#)
  - sizeSpec subclause, [4-40](#)
    - syntax diagram, [4-40](#)
  - skipSpec subclause
    - parameter descriptions, [2-15](#), [2-101](#), [3-127](#)
    - syntax diagram, [2-27](#), [2-104](#), [3-130](#)
  - SNAPSHOT CONTROLFILE parameter, SHOW command, [3-103](#)
  - snapshots
    - control file, [2-43](#)
    - storage, [3-4](#)
    - Volume Shadow Copy Service (VSS), [2-33](#)
  - source databases
    - copying, [2-136](#)
    - used for duplication, [2-141](#)
  - SPFILE SET, overriding, [2-155](#)
  - SPOOL command, [3-106](#)
  - SQL commands
    - executing, [3-110](#)
  - standard output
    - printing scripts, [2-204](#)
  - standby databases
    - backing up, [2-15](#)
    - copying, [2-136](#)
    - fast recovery areas, [2-142](#)
    - password files, [2-140](#)
    - updating (example), [2-54](#)
  - STARTUP command, [3-111](#)
  - stdout, redirecting, [3-106](#)
  - stored scripts, [2-119](#)
    - available information, [2-182](#)
    - deleting, [2-131](#)
    - executing, [2-164](#)
    - printing, [2-204](#)
  - strings
    - valid characters in RMAN commands, [1-2](#)
  - striped files, allocating channels, [2-8](#)
  - striping backup sets, [2-44](#)
  - subclause summary, [1-6](#)
  - substitution variables, [2-90](#)
    - complete list, [4-26](#)
    - example of %D, [2-52](#)
    - example of %F, [2-52](#)
    - example of %U, [2-52](#)
    - in scripts, [2-3](#), [2-119](#), [3-35](#)
    - passing to stored scripts, [2-165](#)
  - switch clause
    - parameter descriptions, [3-113](#)
    - syntax diagram, [3-114](#)
  - SWITCH command, [3-113](#)
    - effect on RESTORE, [3-48](#)
    - switch clause, [3-113](#), [3-114](#)
    - switchFile subclause, [3-113](#), [3-114](#)
  - switchFile subclause
    - parameter descriptions, [3-113](#)
    - syntax diagram, [3-114](#)
  - syntax conventions, [1-1](#)
  - syntax diagrams
    - keywords, [1-2](#)
    - parameters, [1-2](#)
    - placeholders, [1-2](#)
  - syntax, deprecated, [C-1](#)
  - SYSAUX tablespaces, [3-117](#)
  - SYSBACKUP passwords
    - RAC environment, [2-9](#)
  - SYSBACKUP privilege, [2-97](#), [4-12](#)
    - connectStringSpec, [4-11](#)
  - SYSDBA passwords
    - for active duplication, [2-140](#)
  - SYSDBA privilege, [4-12](#)
  - system change numbers (SCN), [2-154](#), [2-167](#)
- ## T
- 
- tables
    - recovering in PDBs, [3-11](#)
  - TABLESPACE DESTINATION parameter, TRANSPORT TABLESPACE command, [3-120](#)
  - tablespace point-in-time recovery (TSPITR), [3-2](#)
  - tablespace recovery (example), [3-21](#)
  - tablespaces
    - renamed, [2-42](#)
    - transparent encryption, [2-80](#)
    - updating file names, [3-113](#)
  - tablespaces7
    - backing up, [2-15](#)
  - tape backups, allocating channels, [2-8](#)
  - target control files, [2-125](#)
  - target databases
    - connecting to, [2-97](#), [4-11](#)

target databases (*continued*)

- deleting, [2-135](#)
- maintaining single metadata catalog, [2-179](#)
- registering, [3-26](#)
- starting from RMAN, [3-111](#)

target times, undoing changes, [2-167](#)

tee command (Linux), [3-82](#)

temp files

- re-creating, [2-143](#)
- renaming, [3-96](#)

tempfileSpec subclause, [4-40](#)

temporary tablespaces, [2-42](#)

time constraints

- partial backups, [2-48](#)

time limits, [4-42](#)

time-based backups, [2-51](#)

time, backup completion, [4-10](#)

TO PLATFORM, [2-21](#)

TO RESTORE POINT parameter

- RECOVER command, [3-11](#)
- SET command, [3-98](#)
- TRANSPORT TABLESPACE command, [3-120](#)

transferring backups, [2-15](#)

transparent encryption, [2-15](#), [2-138](#)

TRANSPORT TABLESPACE command, [3-117](#)

- transpt\_tbs clause, [3-117](#), [3-118](#)
- transpt\_tbs\_optlist subclause, [3-117](#), [3-119](#)

transportable tablespaces

- backing up read-only, [2-42](#)
- creating from backups, [3-117](#)
- duplicating, [2-138](#)

transporting

- tablespaces, [2-108](#)
  - in CDBs, [2-108](#)
  - in PDBs, [2-108](#)

transportOptionList subclause

- parameter descriptions, [2-101](#)
- syntax diagram, [2-104](#)

transpt\_tbs clause

- parameter descriptions, [3-117](#)
- syntax diagram, [3-118](#)

transpt\_tbs\_optlist subclause

- parameter descriptions, [3-117](#)
- syntax diagram, [3-119](#)

## U

---

undo data, [2-86](#)

undo segments, [2-101](#)

UNIX commands, [2-178](#)

unrecoverable operations

- report output, [3-37](#)

UNREGISTER DATABASE command, [3-122](#)

UNTIL SCN parameter

- untilClause subclause, [4-43](#)

UNTIL SEQUENCE parameter

- archlogRange subclause, [4-5](#)
- untilClause subclause, [4-43](#)

UNTIL TIME parameter

- archlogRange subclause, [4-5](#)
- untilClause subclause, [4-43](#)

untilClause subclause, [4-42](#)

unused block compression, [2-44](#)

UPGRADE CATALOG command, [3-125](#)

user names, [4-11](#)

user privileges, [2-97](#)

user-managed backups, [2-59](#)

UTF character set, CLOB storage, [2-101](#)

utlrip script, converting PL/SQL code, [2-137](#)

## V

---

V\$BACKUP\_DEVICE view, [2-10](#), [2-13](#)

V\$DATABASE\_BLOCK\_CORRUPTION view, [2-37](#), [3-3](#), [3-14](#), [3-128](#)

V\$DATABASE.CURRENT\_SCN view, [2-168](#)

V\$DATABASE.FLASHBACK\_ON view, [2-168](#)

V\$FLASHBACK\_DATABASE\_LOG view, [2-172](#)

V\$RMAN\_COMPRESSION\_ALGORITHM view, [2-79](#), [3-91](#)

V\$RMAN\_ENCRYPTION\_ALGORITHMS view, [2-15](#), [2-80](#), [3-92](#)

V\$RMAN\_OUTPUT view, [2-15](#), [3-82](#)

V\$RMAN\_STATUS view, [3-82](#)

V\$SESSION view, [3-98](#)

V\$TABLESPACE view, [2-170](#)

V\$TRANSPORTABLE\_PLATFORM view, [2-101](#)

validate clause

- parameter descriptions, [3-127](#)
- syntax diagram, [3-128](#)

VALIDATE command, [3-127](#)

- blockObject subclause, [3-129](#)
- copyOfSpec subclause, [3-127](#)
- skipSpec subclause, [3-127](#), [3-130](#)
- validate clause, [3-127](#), [3-128](#)
- validateObject subclause, [3-127](#)
- validateOperand subclause, [3-127](#), [3-130](#)

validateObject subclause

- parameter descriptions, [3-127](#)
- syntax diagram, [3-127](#)

validateOperand subclause

- parameter descriptions, [3-127](#)
- syntax diagram, [3-130](#)

validating backups, [3-48](#)

variables in command files, [2-3](#)

views, recovery catalog, [5-1](#)

virtual private catalog, [2-115](#)

virtual private catalog schema, assigning  
privileges, [2-175](#)  
virtual private catalogs  
deleting, [2-134](#)  
virtual recovery catalog, [2-115](#)  
Volume Shadow Copy Service (VSS) snapshots,  
[2-33](#)

## W

---

windows, [4-42](#)  
recovery, [2-48](#)

Windows commands, [2-178](#)

## X

---

XMLType datatype in transportable tablespaces,  
[3-118](#)