

Oracle® AI Database

Oracle True Cache User's Guide



26ai
G43017-05
February 2026

The Oracle logo, consisting of a solid red square with the word "ORACLE" in white, uppercase, sans-serif font centered within it.

ORACLE®

Copyright © 2024, 2026, Oracle and/or its affiliates.

This software and related documentation are provided under a license agreement containing restrictions on use and disclosure and are protected by intellectual property laws. Except as expressly permitted in your license agreement or allowed by law, you may not use, copy, reproduce, translate, broadcast, modify, license, transmit, distribute, exhibit, perform, publish, or display any part, in any form, or by any means. Reverse engineering, disassembly, or decompilation of this software, unless required by law for interoperability, is prohibited.

The information contained herein is subject to change without notice and is not warranted to be error-free. If you find any errors, please report them to us in writing.

If this is software, software documentation, data (as defined in the Federal Acquisition Regulation), or related documentation that is delivered to the U.S. Government or anyone licensing it on behalf of the U.S. Government, then the following notice is applicable:

U.S. GOVERNMENT END USERS: Oracle programs (including any operating system, integrated software, any programs embedded, installed, or activated on delivered hardware, and modifications of such programs) and Oracle computer documentation or other Oracle data delivered to or accessed by U.S. Government end users are "commercial computer software," "commercial computer software documentation," or "limited rights data" pursuant to the applicable Federal Acquisition Regulation and agency-specific supplemental regulations. As such, the use, reproduction, duplication, release, display, disclosure, modification, preparation of derivative works, and/or adaptation of i) Oracle programs (including any operating system, integrated software, any programs embedded, installed, or activated on delivered hardware, and modifications of such programs), ii) Oracle computer documentation and/or iii) other Oracle data, is subject to the rights and limitations specified in the license contained in the applicable contract. The terms governing the U.S. Government's use of Oracle cloud services are defined by the applicable contract for such services. No other rights are granted to the U.S. Government.

This software or hardware is developed for general use in a variety of information management applications. It is not developed or intended for use in any inherently dangerous applications, including applications that may create a risk of personal injury. If you use this software or hardware in dangerous applications, then you shall be responsible to take all appropriate fail-safe, backup, redundancy, and other measures to ensure its safe use. Oracle Corporation and its affiliates disclaim any liability for any damages caused by use of this software or hardware in dangerous applications.

Oracle®, Java, MySQL, and NetSuite are registered trademarks of Oracle and/or its affiliates. Other names may be trademarks of their respective owners.

Intel and Intel Inside are trademarks or registered trademarks of Intel Corporation. All SPARC trademarks are used under license and are trademarks or registered trademarks of SPARC International, Inc. AMD, Epyc, and the AMD logo are trademarks or registered trademarks of Advanced Micro Devices. UNIX is a registered trademark of The Open Group.

This software or hardware and documentation may provide access to or information about content, products, and services from third parties. Oracle Corporation and its affiliates are not responsible for and expressly disclaim all warranties of any kind with respect to third-party content, products, and services unless otherwise set forth in an applicable agreement between you and Oracle. Oracle Corporation and its affiliates will not be responsible for any loss, costs, or damages incurred due to your access to or use of third-party content, products, or services, except as set forth in an applicable agreement between you and Oracle.

Contents

1 Overview of Oracle True Cache

1.1	About Oracle True Cache	1
1.2	Benefits of Oracle True Cache	1
1.3	How True Cache Works	2
1.4	Considerations for Using True Cache	2
1.5	Application Usage Models	2
1.6	Lock-Free Concurrency Control	3

2 Configuring True Cache

2.1	Overview of the True Cache Configuration	1
2.1.1	Uniform Configuration	1
2.1.2	Partitioned Configuration	1
2.1.3	True Cache Configuration Process Overview	1
2.1.4	Best Practices for Database Application Services	2
2.1.5	Best Practices for Maximum Availability Architecture (MAA) with True Cache	2
2.1.6	Pluggable Database (PDB) Behavior and Restrictions with True Cache	2
2.2	Configuring True Cache with DBCA	3
2.2.1	Prerequisites	3
2.2.2	Creating True Cache with DBCA	4
2.2.3	Configuring True Cache Database Application Services with DBCA	5
2.2.4	Oracle DBCA Commands and Parameters for True Cache	8
2.2.4.1	configureDatabase	8
2.2.4.2	createTrueCache	9
2.3	Configuring True Cache Manually	12
2.3.1	Prerequisites	12
2.3.2	Creating True Cache Manually	13
2.3.2.1	Edit the tnsnames.ora File for True Cache and the Primary Database	13
2.3.2.2	Configure and Start the Local Listener on the True Cache Node	14
2.3.2.3	Copy the Password File or Wallet from the Primary Database to the True Cache Node	15
2.3.2.4	Prepare a PFILE for True Cache	16
2.3.2.5	Create and Start True Cache	18
2.3.3	Configuring True Cache Database Application Services Manually	19

2.3.3.1	Create Database Application Services on the Primary Database	19
2.3.3.2	Verify That the Database Application Services Are Created	21
2.3.3.3	Start the Database Application Services	21
2.4	Deploying True Cache for an Oracle RAC Primary Database	23
2.5	Verifying the True Cache Configuration	25
2.5.1	Verifying That True Cache Is Working as Expected	25
2.5.2	Verifying the Remote Listener Configuration	25
2.5.3	Verifying the True Cache and Primary Database Application Services	26
2.6	Enabling DML Redirection	27
3	Deploying True Cache on Oracle Base Database Service	
4	Deploying True Cache in Containers	
5	Shutting Down and Starting True Cache	
5.1	Shutting Down True Cache	1
5.2	Starting True Cache	1
6	Monitoring True Cache	
6.1	Monitoring True Cache with the V\$TRUE_CACHE View	1
6.1.1	V\$TRUE_CACHE Columns	2
6.2	Monitoring True Cache with the V\$TRUE_CACHE_STAT View	2
6.2.1	V\$TRUE_CACHE_STAT Columns	3
6.3	Using the Automatic Workload Repository for True Cache	4
6.4	Monitoring True Cache with Oracle Enterprise Manager	6
7	Using Oracle True Cache in Your Applications	
7.1	Methods for Connecting to True Cache	1
7.2	Sample Java Code Using the JDBC Thin Driver	2
7.3	Sample Java Code for Applications Using a Native Connection to the Database	4
7.4	Best Practices for Load Balancing in a Uniform Configuration	5
8	Complementary Caching Features	
8.1	Server-Side Result Set Cache	1
8.2	KEEP Buffer Pool	1
8.2.1	Overview of Using the KEEP Buffer Pool with True Cache	2
8.2.1.1	Supported Objects	2

8.2.1.2	How True Cache Works with the Primary Database Buffer Cache	2
8.2.2	Configuring DB_KEEP_CACHE_SIZE on True Cache	3
8.2.3	Assigning Objects to the KEEP Buffer Pool for True Cache	3
8.2.3.1	TRUE_CACHE_KEEP Procedure	3
8.2.4	Removing an Object's KEEP Buffer Pool Assignment for True Cache	4
8.2.4.1	TRUE_CACHE_UNKEEP Procedure	4
8.2.5	Viewing a List of KEEP Objects on True Cache	5
8.2.5.1	V\$TRUE_CACHE_KEEP Columns	5
8.3	Database Smart Flash Cache	6

9 Deleting True Cache

9.1	Using DBCA to Delete True Cache	1
9.1.1	Cleaning Up the True Cache Services from the Primary Database	1
9.1.2	Deleting True Cache from the True Cache Node	1
9.2	Deleting True Cache Manually	2

10 Deploying Oracle True Cache with Oracle Global Data Services

10.1	Global Data Services Overview	1
10.2	True Cache Integration with Global Data Services	2
10.3	True Cache Implementation with Global Data Services	2
10.3.1	Configuring True Cache for High Availability (Failover to Read-Write)	2
10.3.2	Using True Cache for Read Offloading and Write Redirection	3
10.3.3	Using True Cache for a Singleton Read-Only Service	4
10.3.4	Configuring True Cache as a Reader Farm (Read-Only)	5
10.4	Configuring Global Data Services for True Cache	6
10.4.1	Set Up the Environment	7
10.4.2	Install the Global Service Manager Software	7
10.4.3	Configure True Cache	7
10.4.4	Configure the GDS Catalog Database	8
10.4.5	Create the GDS Catalog	8
10.4.6	Set Up Global Service Managers	9
10.4.7	(Optional) Set Up Regions	9
10.4.8	Set Up the GDS Pool	10
10.4.9	Set Up Global Services	11
10.4.9.1	Global Service Best Practices for JDBC	13
10.4.9.2	GDSCTL add service Options	14
10.4.10	Set Up the Client TNS Entry	15
10.5	True Cache Restrictions with Oracle Global Data Services	16

A	True Cache Error Messages	
B	True Cache Database Statistics Descriptions	
C	True Cache Wait Events	
D	Licensing for True Cache	
E	Troubleshooting True Cache	
E.1	Rerunning DBCA	E-1
E.1.1	Rerunning DBCA After Creating True Cache	E-1
E.1.2	Rerunning DBCA After Configuring True Cache Database Application Services	E-1
E.2	Preventing SRVCTL from Restarting True Cache Services for Oracle RAC Primary Databases	E-2

1

Overview of Oracle True Cache

Oracle True Cache is an in-memory, consistent, and automatically managed SQL and key-value (object or JSON) cache for Oracle AI Database.

For an interactive tour, see [Oracle True Cache Technical Architecture](#).

1.1 About Oracle True Cache

True Cache is an in-memory, read-only cache in front of an Oracle AI Database.

Like Oracle Active Data Guard, True Cache is a fully functional, read-only replica of the primary database, except that it's mostly diskless.

Modern applications often require a high number of connections and fast, low-latency access to the data. A popular approach is to place caches in front of the database because applications typically perform many more reads than updates, and they can read from the cache without affecting the database performance. For example, an airline reservation system reads data frequently as people shop for flights, and it's okay if the data isn't the most current compared to what's in the database. The application only needs to access the most current data when someone reserves a flight.

Unlike conventional caches, True Cache automatically keeps the most frequently accessed data in the cache, and it keeps the cache consistent with the primary database, other objects in the same cache, and other caches. It caches all Oracle AI Database objects and data types, including JSON.

Because True Cache implements Oracle AI Database security policies, you can control access to the cache. This enables you to cache sensitive data, like private personal information, that you might not ordinarily cache.

1.2 Benefits of Oracle True Cache

Oracle True Cache provides several business benefits related to application development and performance.

- Improves scalability and performance by offloading queries from the primary database.
- Reduces application response time and network latency by deploying True Cache closer to the application. This especially benefits situations where a database is in a different location than the application due to data residency requirements.
- Creates a large, in-memory storage area by dividing data across multiple True Caches. The total size of the cached data across all True Caches can be much larger than it would be for a single primary database or cache.
- Automatically maintains the cache contents.
- Simplifies development and maintenance by being transparent to the application.

1.3 How True Cache Works

At a high level, here's how Oracle True Cache works.

- An application decides whether to query data from True Cache or the primary database. For details on how this works, see [Application Usage Models](#).
- True Cache satisfies queries by using data that's cached in its memory. When the data isn't in the cache, True Cache fetches the data from the primary database.
- True Cache is empty when it starts up, so it reads large chunks of data to populate the cache. After a block is cached, it's updated automatically through redo apply from the primary database. This is similar to the update mechanism used in Oracle Active Data Guard.
- A query to True Cache returns only committed data, and the data is always consistent.
- Like all caches, the True Cache data might not be the most current data as it exists in the primary database.
- If multiple True Caches exist and serve the same database application service, the listener automatically distributes and load balances sessions to each cache.

1.4 Considerations for Using True Cache

Consider these points when deciding whether to use Oracle True Cache.

- You need to configure enough memory for True Cache so your most frequently accessed data will stay in memory.
- True Cache only needs a small amount of storage for the standby redo log files. Configuration files like control files, the `SPFILE`, and temporary data files are automatically created.
- True Cache is a read-only cache, so you can't directly update the cache, but you can use DML redirection to indirectly update the cache.

Related Topics

- [Enabling DML Redirection](#)
True Cache is a read-only cache, so you can't directly update the cache, but you can use DML redirection to indirectly update the cache.

1.5 Application Usage Models

Applications can use True Cache in two ways.

- **Two physical connections**

The application maintains two physical connections: one to the primary database and one to True Cache. Each connection has a database application service, and the application chooses which connection to use based on whether it's reading or writing. You can use this model with any existing client drivers and any programming language.

The application sends queries that don't need to see the most current data to True Cache through a True Cache database application service. The application sends other queries and updates to the primary database through the primary database application service.

- **One logical connection (JDBC Thin driver)**

The application maintains one logical connection that uses the database application service for the primary database. The JDBC Thin driver (starting with Oracle AI Database 26ai) maintains physical connections to the primary database and True Cache. This model only works with Java applications.

The application switches between the primary database and True Cache without having to specify an instance name. The application uses special calls to flag the logical connection as read-only or read-write. If it's read-only, the query is sent to True Cache. Otherwise, it's sent to the primary database.

- **Single Oracle Call Interface (OCI) session pool**

Starting with Oracle AI Database 26ai, Release Update 23.26.0, you can use a single OCI session pool to manage connections to both a primary database and True Cache.

The application can either request a session from the primary database (default) or explicitly request a read-only session from True Cache. There's also an option to prefer True Cache, if available, and otherwise fall back to the primary database.

Related Topics

- [Using Oracle True Cache in Your Applications](#)

When True Cache is configured, applications must decide whether to query data from True Cache or the primary database.

1.6 Lock-Free Concurrency Control

For applications that work with JSON documents, Oracle extends HTTP entity tag (ETAG) support to implement lock-free, optimistic concurrency control.

A database GET request to True Cache automatically computes the ETAG and inserts it into the returned document. When the modified document is PUT back into the primary database, the following occurs:

1. The database verifies that the underlying document rows still match the ETAG that was computed by the GET request.
2. If the rows match the ETAG, the rows are atomically updated.
3. If there's not a match, another user has changed the data and the PUT request is rejected.
4. The PUT request can be retried using the new data.

2

Configuring True Cache

You can configure True Cache using the Database Configuration Assistant (DBCA) or you can configure it manually.

Note

True Cache for Oracle AI Database Free has a simplified configuration process. Get started with the *Oracle AI Database Free Installation Guide* for your platform. See [Configuring True Cache on Oracle AI Database Free \(Linux\)](#) or [Configuring True Cache on Oracle AI Database Free \(Windows\)](#).

2.1 Overview of the True Cache Configuration

A True Cache environment can have a uniform or partitioned configuration.

2.1.1 Uniform Configuration

In a uniform configuration, you can deploy multiple, identical True Caches that use the same True Cache database application service.

Client sessions are evenly distributed among True Caches, which all cache the same set of data.

See the following technical architecture diagram for details and an example of a uniform configuration:

[True Cache Uniform Configuration](#)

2.1.2 Partitioned Configuration

In a partitioned configuration, the data is divided across multiple True Caches, which each cache a different subset of the data.

The total size of the cached data across all True Caches can be much larger than it would be for a single primary database or a single cache in a uniform configuration.

See the following technical architecture diagrams for details and examples of partitioned configurations:

- [True Cache Configuration with colocation_tag](#)
- [True Cache Partitioned Configuration with Multiple Services](#)

2.1.3 True Cache Configuration Process Overview

At a high level, creating a True Cache configuration involves the following steps.

1. Configure the network for True Cache and the primary database, and optionally create a remote listener for high availability.

2. Create True Cache.
3. Create and start the True Cache database application services.

2.1.4 Best Practices for Database Application Services

Associate each primary database application service with a corresponding True Cache database application service.

To distinguish the True Cache database application services, it's a good practice to use the primary service name followed by `_TC`.

For example, if the primary service is `SALES`, the True Cache service would be `SALES_TC`.

Also, only start the True Cache services on True Caches, and make sure they're read-only.

2.1.5 Best Practices for Maximum Availability Architecture (MAA) with True Cache

Follow these best practices for maximum availability with True Cache.

- Configure True Cache for high availability with two identical True Caches per dataset using the uniform configuration architecture. To learn more, see [Uniform Configuration](#).
- Use the JDBC 26ai UCP connection configuration for the application to ensure minimal impact on the application if one True Cache becomes unavailable.
- Before enabling the database application service for True Cache, populate the cache by running critical workload queries. To learn more about how data is cached, see [How True Cache Works](#).
- Before shutting down True Cache for planned maintenance, stop the database application service on True Cache.
- Partition or design True Caches to minimize fetches from the primary database.

2.1.6 Pluggable Database (PDB) Behavior and Restrictions with True Cache

To achieve maximum availability, PDBs on True Cache and the primary database have the following behavior and restrictions.

- Because non-CDB database are deprecated in Oracle AI Database 26ai, True Cache does not support non-CDB primary databases.
- You can't perform administration tasks (for example, opening, closing, or shutting down) on PDBs on True Cache. However, applications can connect to specific PDBs on True Cache the same way they do for primary databases and Oracle Active Data Guard.
- True Cache's PDB availability depends on the PDB state on the primary database.
 - When True Cache connects to the primary database, all open PDBs on the primary database (in any Oracle RAC instances) are open on True Cache.
 - If a PDB isn't open on the primary database on all Oracle RAC instances, then True Cache effectively can't read anything from that PDB and sees the PDB in a mounted state. When the primary database opens the PDB, then True Cache automatically opens it as well.
 - When a PDB is closed on the primary database, it's marked as disconnected on True Cache and never closes, unless some other action on the primary database requires

the PDB to close, like dropping it, renaming it, or using flashback. Otherwise, the PDB remains open forever. Even if the primary CDB shuts down, when the primary CDB restarts, True Cache checks whether each PDB can resume or has to be closed and restarted.

- When the primary database shuts down, `ROOT` is marked as disconnected on True Cache, and it may remain disconnected for a maximum of 24 hours.

The following example illustrates how a PDB can be open on one True Cache and closed on another True Cache that's connected to the same primary database.

1. PDB 1 is open on the primary database.
2. True Cache 1 connects to the primary database and sees that PDB 1 is open, so it opens PDB 1.
3. The primary database closes PDB 1, but PDB 1 stays open on True Cache 1.
4. The primary database is bounced but doesn't reopen PDB 1.
5. True Cache 2 connects to the primary database and sees PDB 1 is in a mounted state, so PDB 1 stays closed and mounted on True Cache 2.

2.2 Configuring True Cache with DBCA

The simplest way to configure a True Cache environment is to use Database Configuration Assistant (DBCA).

DBCA is an assistant tool that comes with Oracle AI Database to simplify the process of creating, configuring, and managing Oracle AI Database and True Cache.

Note

True Cache for Oracle AI Database Free has a simplified configuration process. Get started with the *Oracle AI Database Free Installation Guide* for your platform. See [Configuring True Cache on Oracle AI Database Free \(Linux\)](#) or [Configuring True Cache on Oracle AI Database Free \(Windows\)](#).

2.2.1 Prerequisites

Before configuring True Cache, complete the following prerequisites.

- Set up a network path to access the primary (source) database with an Easy Connect (EZConnect) string from the True Cache node.
- Install the Oracle AI Database software on the True Cache nodes.
- Ensure that a primary database is running on the primary node in archive logging (ARCHIVELOG) mode.

The primary database must be in ARCHIVELOG mode to ship redo log files to the True Cache node. DBCA verifies that the primary database is in ARCHIVELOG mode.

If the primary database is not in ARCHIVELOG mode, restart it in mount mode, run the `ALTER DATABASE ARCHIVELOG` command, and open the primary database again.

- Don't set `LOG_ARCHIVE_CONFIG` and `LOG_ARCHIVE_DEST_n` on the primary database. True Cache automatically configures these for the primary database.

- If `LOG_ARCHIVE_DEST` is set on the primary database, remove it. `LOG_ARCHIVE_DEST` is incompatible with the `LOG_ARCHIVE_DEST_n` parameters. For more information, see [LOG_ARCHIVE_DEST](#).

2.2.2 Creating True Cache with DBCA

Follow these steps to create True Cache with DBCA.

1. Copy the password file, and optionally the Transparent Data Encryption (TDE) wallet, from the primary database to the True Cache node. You can use either of the following methods:

- Manually copy the primary database's password file (and optional TDE wallet) to any location on the True Cache node.
- Run a DBCA command on the primary database to package the password file (and optional TDE wallet) into a configuration BLOB file. Then copy the file to the True Cache node and ensure that the file is owned by the Oracle Home user.

Use the following command to prepare the configuration BLOB file on the primary database:

```
$ORACLE_HOME/bin/dbca -configureDatabase -prepareTrueCacheConfigFile -
sourceDB primary_db_sid_or_db_unique_name -trueCacheBlobLocation
primary_db_config_blob_path -silent
```

Example:

```
$ORACLE_HOME/bin/dbca -configureDatabase -prepareTrueCacheConfigFile -
sourceDB primdbli -trueCacheBlobLocation /tmp/blob_loc2 -silent
```

For descriptions of the parameters, see [configureDatabase](#).

2. On the True Cache node, run the `-createTrueCache` command to complete the True Cache configuration and start True Cache.

Choose one of the following command formats, depending on the method that you used to copy the primary database's password file (and optional TDE wallet) to the True Cache node in step 1.

- If you manually copied the password file (and optional TDE wallet), use this command:

```
$ORACLE_HOME/bin/dbca -createTrueCache -gdbName true_cache_global_name -
sid true_cache_sid -sourceDBConnectionString
primary_db_easy_connect_string -passwordFileFromSourceDB
password_file_path -sgaTargetInMB sga_memory_size -
pgaAggregateTargetInMB pga_memory_size -silent
```

Example using a password file:

```
$ORACLE_HOME/bin/dbca -createTrueCache -gdbName tcdb1 -sid tcdb1 -
sourceDBConnectionString primary.example.com:1522/primdbli.example.com -
passwordFileFromSourceDB /tmp/password_loc2/orapwddbmc1 -sgaTargetInMB
20000 -pgaAggregateTargetInMB 4000 -silent
```

- If you created the configuration BLOB file, use this command:

```
$ORACLE_HOME/bin/dbca -createTrueCache -gdbName true_cache_global_name -  
sid true_cache_sid -sourceDBConnectionString  
primary_db_easy_connect_string -trueCacheBlobFromSourceDB  
true_cache_config_blob_path -sgaTargetInMB sga_memory_size -  
pgaAggregateTargetInMB pga_memory_size -tdeWalletLoginType AUTO_LOGIN -  
listeners listener_name -silent
```

Example using a TDE wallet:

```
$ORACLE_HOME/bin/dbca -createTrueCache -gdbName tcdbl -sid tcdbl -  
sourceDBConnectionString primary.example.com:1522/primdbli.example.com -  
trueCacheBlobFromSourceDB /tmp/blob_loc2/blob.tar.gz -sgaTargetInMB  
20000 -pgaAggregateTargetInMB 4000 -tdeWalletLoginType AUTO_LOGIN -  
listeners LISTENER -silent
```

For descriptions of the parameters, see [createTrueCache](#).

Note

For Oracle RAC primary databases, set the `-sourceDBConnectionString` parameter to `SCAN:port/service_name`.

Related Topics

- [Rerunning DBCA After Creating True Cache](#)

If you need to rerun DBCA after creating True Cache, clean up the True Cache node first.

2.2.3 Configuring True Cache Database Application Services with DBCA

To use True Cache with the JDBC Thin driver, for each primary database application service that you want to cache, create a corresponding True Cache database application service.

This makes it easy for applications to switch an existing JDBC connection from a primary database to True Cache without having to change the JDBC connection URL. This is possible with the 26ai JDBC Thin driver by setting the `ReadOnly` parameter of the connection to `TRUE` or `FALSE`.

On the primary database, complete the following steps:

1. Configure the remote listener.

Note

Check to see if Valid Node Checking for Registration (VNCR) is configured for the listener. If so, add True Cache to the `REGISTRATION_INVITED_NODES_LISTENER` parameter in the `listener.ora` file of the remote listener.

Note

For Oracle RAC primary databases, add the True Cache node to the invited node list for the SCAN listener by using the `srvctl` command line utility. (Don't manually edit the `listener.ora` file as the grid owner user.)

For example:

```
srvctl modify scan_listener -invitednodes true_cache_host -
endpoints TCP:port
```

2. Create and start a primary database application service to use with the True Cache service, and then verify that the service is running.

Choose one of the following options based on the primary database configuration:

- For single instance primary databases, use the `DBMS_SERVICE` PL/SQL package. For services that are specific to a pluggable database (PDB), connect to the specific PDB, or set the correct PDB container in your session before starting the service using `DBMS_SERVICE`.

Here's an example using the `DBMS_SERVICE` package for a single instance primary database:

```
BEGIN
  DBMS_SERVICE.CREATE_SERVICE('SALES', 'SALES');
  DBMS_SERVICE.START_SERVICE('SALES');
END;
/
PL/SQL procedure successfully completed.
```

```
SELECT service_id, name, true_cache_service FROM v$active_services
WHERE name='SALES';
```

```
SERVICE_ID NAME                TRUE_CACHE_SERVICE
-----
        6 SALES
```

```
// TRUE_CACHE_SERVICE will be filled in by this (dbca -
configureTrueCacheInstanceService) command
```

- For Oracle RAC primary databases, use the `srvctl` command line utility to add the primary database service. Start the service on the primary instance. Use `srvctl` only for Oracle Clusterware-managed instances.

```
srvctl add service -db primary_db_unique_name -service
primary_db_service_name -preferred primary_db_instance_list -pdb
primary_pdb_name
```

```
srvctl start service -d primary_db_unique_name -s
primary_db_service_name
```

For example:

```
srvctl add service -db primdbli -service sales -preferred
primdbli1,primdbli2 -pdb sales_pdb
```

```
srvctl start service -d primdbli -s sales
```

3. Run the `dbca -configureDatabase` command with the `-configureTrueCacheInstanceService` parameter to configure True Cache.

This configures the True Cache database application service on the primary database and then starts the True Cache service on True Cache. Run this command for each True Cache database application service.

Note

The primary database application service must already exist before you run this command.

Note

For a uniform True Cache configuration with multiple True Caches serving the same service, run DBCA once. For `-trueCacheConnectString`, use the connect string for one True Cache node CDB. Then manually start the service on the other True Caches (see step 5).

```
$ORACLE_HOME/bin/dbca -configureDatabase -
configureTrueCacheInstanceService -sourceDB
primary_db_sid_or_db_unique_name -trueCacheConnectString
true_cache_cdb_easy_connect_string -trueCacheServiceName
true_cache_service_name -serviceName primary_db_service_name -pdbName
primary_pdb_name -silent
```

Example:

```
$ORACLE_HOME/bin/dbca -configureDatabase -
configureTrueCacheInstanceService -sourceDB primdbli -
trueCacheConnectString tc.example.com:1522/tcdb1.example.com -
trueCacheServiceName sales_tc -serviceName sales -pdbName sales_pdb -silent
```

For descriptions of the parameters, see [configureDatabase](#).

4. After the database application service starts on True Cache, use the `lsnrctl` command to validate the remote listener services for the True Cache service registration.

See [Verifying the Remote Listener Configuration](#).

5. For a uniform True Cache configuration with multiple True Caches serving the same service, start the service on all additional True Caches.

Run the command on the True Cache PDBs.

For example:

```
EXEC DBMS_SERVICE.START_SERVICE('SALES_TC');
```

Related Topics

- [CREATE_SERVICE Procedure](#)
- [MODIFY_SERVICE Procedure](#)
- [srvctl modify scan_listener](#)
- [Uniform Configuration](#)
In a uniform configuration, you can deploy multiple, identical True Caches that use the same True Cache database application service.
- [Rerunning DBCA After Configuring True Cache Database Application Services](#)
If you need to rerun DBCA after configuring True Cache database application services, you might need to delete the True Cache service from the primary pluggable database (PDB) using the DBMS_Service package.

2.2.4 Oracle DBCA Commands and Parameters for True Cache

Use the following DBCA commands and parameters to configure True Cache.

2.2.4.1 configureDatabase

The `configureDatabase` command configures the primary database for True Cache. Run this command on the primary database.

Parameters

For True Cache, use the `dbca -configureDatabase` command with the following syntax.

Note

This table lists the `configureDatabase` parameters that are specific to True Cache. For the full syntax and parameters, see [configureDatabase](#) in the *Oracle AI Database Multitenant Administrator's Guide*.

Table 2-1 `configureDatabase` Parameters

Parameter	Required/ Optional	Description
<code>--prepareTrueCacheConfigFile</code>	Required for True Cache	Use this option to prepare a configuration BLOB file that contains the primary database's password file or wallet. Enter the following additional parameters for this option: <ul style="list-style-type: none"> • <code>-sourceDB</code>: Enter the primary database system identifier (SID) or database unique name (<code>DB_UNIQUE_NAME</code>). • <code>-tdeWalletPassword</code>: If the primary database uses a Transparent Data Encryption (TDE) wallet, enter the password for the wallet. This parameter is optional. • <code>-trueCacheBlobLocation</code>: Enter the path where you want to save the configuration BLOB file on the primary database. This parameter is optional.

Table 2-1 (Cont.) configureDatabase Parameters

Parameter	Required/ Optional	Description
- configureTrueCacheInstanceService	Required for True Cache	Use this option to configure the True Cache database application service on the primary database and start the service on True Cache. Enter the following additional parameters for this option: <ul style="list-style-type: none"> -serviceName: Enter the primary database application service name. -sourceDB: For a single instance database, enter the primary database SID. For an Oracle RAC database, enter the database unique name (DB_UNIQUE_NAME). -trueCacheConnectionString: Enter the Easy Connect (EZConnect) string to connect to the True Cache CDB. Example: host:port/service_name -trueCacheServiceName: Enter a name for the True Cache database application service. -pdbName: Enter the primary pluggable database (PDB) name. This parameter is required to create the True Cache service for a PDB. In this case serviceName is an existing PDB service name in the primary database.
- cleanupTrueCacheInstanceService	Required for True Cache	Use this option to remove the True Cache database application services from the primary database configuration if, for example, you delete True Cache. Enter the following additional parameters for this option: <ul style="list-style-type: none"> -serviceName: Enter the primary database application service name. -sourceDB: Enter the primary database SID or database unique name (DB_UNIQUE_NAME). -trueCacheConnectionString: Enter the Easy Connect (EZConnect) string to connect to the True Cache CDB. Example: host:port/service_name -trueCacheServiceName: Enter a name for the True Cache database application service.

2.2.4.2 createTrueCache

The `createTrueCache` command configures True Cache. Run this command on the True Cache node.

Syntax and Parameters

Use the `dbca -createTrueCache` command with the following syntax:

```
dbca -createTrueCache
    -dbUniqueName true_cache_unique_name | -gdbName true_cache_global_name
    -sourceDBConnectionString primary_db_easy_connect_string
    -trueCacheBlobFromSourceDB true_cache_config_blob_path | -
passwordFileFromSourceDB password_file_path
    [-tdeWalletFromSourceDB tde_wallet_path]
    [-createListener new_database_listener]
    [-datafileDestination true_cache_control_file_path
```

```

[-initParams initialization_parameters_list
  [-initParamsEscapeChar initialization_parameters_escape_character]]
[-listeners listener_list]
[-pgaAggregateTargetInMB pga_memory_size]
[-sgaTargetInMB sga_memory_size]
[-sid true_cache_sid]
[-sourceTdeWalletPassword primary_db_wallet_password]
[-tdeWalletLoginType {PASSWORD | AUTO_LOGIN | LOCAL_AUTO_LOGIN}]
[-tdeWalletRoot tde_wallet_root_init_parameter]
[-useWalletForDBCredentials {true | false}
  -dbCredentialsWalletLocation wallet_files_directory
  [-dbCredentialsWalletPassword wallet_account_password]]

```

Table 2-2 createTrueCache Parameters

Parameter	Required/ Optional	Description
-dbUniqueName <i>true_cache_unique_name</i> or -gdbName <i>true_cache_global_name</i>	Required	Enter either the unique name for this True Cache or the global database name.
-sourceDBConnectionString <i>primary_db_easy_connect_string</i>	Required	Enter the Easy Connect (EZConnect) string to connect to the primary database. Example: host:port/service_name Note: For Oracle RAC primary databases, set the -sourceDBConnectionString parameter to SCAN:port/service_name.
-trueCacheBlobFromSourceDB <i>true_cache_config_blob_path</i> or -passwordFileFromSourceDB <i>password_file_path</i>	Required	Enter one of the following: <ul style="list-style-type: none"> The full path and file name for the configuration BLOB file that contains the primary database's password file or wallet. This is the path where the file is located on the True Cache node. The path to the primary database's password file that was copied to the True Cache node. If you use -passwordFileFromSourceDB, you can also enter the following additional parameter: -tdeWalletFromSourceDB: Enter the path to the primary database's Transparent Data Encryption (TDE) wallet file that was copied to the True Cache node. You can copy and use the TDE wallet file only if the primary (source) database has TDE enabled. Otherwise, the wallet file isn't required.
-createListener <i>new_database_listener</i>	Optional	Enter a new database listener to be created and to register the database in the form <i>LISTENER_NAME:PORT</i> .

Table 2-2 (Cont.) createTrueCache Parameters

Parameter	Required/ Optional	Description
-datafileDestination <i>true_cache_control_file_path</i>	Optional	Enter the location where the True Cache control file, standby redo log groups, and temporary data files are to be stored. If True Cache uses Oracle Automatic Storage Management (ASM) storage or Oracle Exadata Exascale Storage Vault, prefix the path with the ASM disk group or Exascale Vault name for -datafileDestination and use the following additional parameter: -useOMF: Enter true to use Oracle-Managed Files (OMF). Otherwise, enter false. Note: Make sure the directory has enough space to hold the temporary files in the primary database plus four times the maximum online redo log size per block size and per thread. For example, if the primary has two redo log threads and each thread has two 2GB online redo logs with 512-byte blocks, two 4GB online redo logs with 512-byte blocks, and three 8GB online redo logs with 4KB blocks, use the following formula: 2 threads x ((4GB x 2, for the biggest of the 512-byte blocks) + (8KB x 3, for the 4KB blocks)).
-initParams <i>initialization_parameters_list</i>	Optional	Enter a comma-separated list of name=value pairs with additional initialization parameter values for this True Cache. You can also provide the -initParamsEscapeChar parameter for using a specific escape character between multiple values of an initialization parameter. If an escape character is not specified, backslash (\) is used as the default escape character.
-listeners <i>listeners_list</i>	Optional	If one or more listeners already exist, enter a comma-separated list of existing listeners that the database can be configured with. If you don't specify the existing listeners, DBCA creates a new listener.
-pgaAggregateTargetInMB <i>pga_memory_size</i>	Optional	Enter a value in MB for the target aggregate Program Global Area (PGA) memory to make available to all server processes that are attached to this True Cache.
-sgaTargetInMB <i>sga_memory_size</i>	Optional	Enter a value in MB for the System Global Area (SGA) memory size for this True Cache.
-sid <i>true_cache_sid</i>	Optional	Enter the system identifier (SID) for this True Cache.
-sourceTdeWalletPassword <i>primary_db_wallet_password</i>	Optional	If the primary database uses a TDE wallet, enter the password for the wallet.
-tdeWalletLoginType {PASSWORD AUTO_LOGIN LOCAL_AUTO_LOGIN}	Optional	Oracle recommends the AUTO_LOGIN or LOCAL_AUTO_LOGIN wallet for True Cache to avoid having to manually open a password wallet for each True Cache startup. To learn more about wallet types, see About Oracle AI Database Wallets
-tdeWalletRoot <i>tde_wallet_root_init_parameter</i>	Optional	Enter the location for the True Cache TDE wallet root initialization parameter, which specifies where to place the wallet for True Cache.

Table 2-2 (Cont.) createTrueCache Parameters

Parameter	Required/ Optional	Description
-useWalletForDBCredentials {true false}	Optional	<p>If the primary database uses Oracle Wallet for database credentials, enter <code>true</code>. The default is <code>false</code>.</p> <p>If you enter <code>true</code>, also enter the following additional parameters:</p> <ul style="list-style-type: none"> -dbCredentialsWalletLocation: Enter the path of the directory that contains the Oracle Wallet files. -dbCredentialsWalletPassword: Enter the password for the Oracle Wallet account to open the wallet with auto-login disabled. This parameter is optional.

Related Topics

- *Oracle AI Database Multitenant Administrator's Guide*

2.3 Configuring True Cache Manually

Follow these steps to set up a True Cache environment manually if you're not using the Database Configuration Assistant (DBCA).

2.3.1 Prerequisites

Before configuring True Cache, complete the following steps.

- Install the Oracle AI Database software on the True Cache nodes.
- Ensure that a primary database is running on the primary node in archive logging (ARCHIVELOG) mode.

The primary database must be in ARCHIVELOG mode to ship redo log files to the True Cache node. To see if the primary database is in ARCHIVELOG mode, enter the following SQL query:

```
SELECT log_mode FROM v$database;
```

```
LOG_MODE
-----
ARCHIVELOG
```

If the primary database is not in ARCHIVELOG mode, restart it in mount mode, run the `ALTER DATABASE ARCHIVELOG` command, and open the primary database again.

- Don't set `LOG_ARCHIVE_CONFIG` and `LOG_ARCHIVE_DEST_n` on the primary database. True Cache automatically configures these for the primary database.
- If `LOG_ARCHIVE_DEST` is set on the primary database, remove it. `LOG_ARCHIVE_DEST` is incompatible with the `LOG_ARCHIVE_DEST_n` parameters. For more information, see [LOG_ARCHIVE_DEST](#).

2.3.2 Creating True Cache Manually

Follow these steps to create True Cache manually.

2.3.2.1 Edit the tnsnames.ora File for True Cache and the Primary Database

Configure the database network connections by editing the `tnsnames.ora` file on both True Cache and the primary database.

On most Linux platforms, you find the `tnsnames.ora` file in the `$ORACLE_HOME/network/admin` directory.

You can create this file manually or by using Oracle Net Configuration Assistant (NETCA).

Add the following information to all primary database and True Cache `tnsnames.ora` files if the information isn't already present:

- Network names for the primary database and all True Caches. These are needed to send redo to True Cache, and they enable redo shipping to work even if the database application services are not yet created.
- All primary database and True Cache database application service names. One True Cache can support multiple database application services that are started simultaneously.
- All participating listener network aliases, if you're using a remote listener.

Here are examples of the entries in the `tnsnames.ora` files for True Cache and the primary database:

```
# True Cache network name

tcdbli =
  (DESCRIPTION =
    (ADDRESS_LIST =
      (ADDRESS = (PROTOCOL = TCP)(HOST = true_cache_host)(PORT = 1521))
    )
    (CONNECT_DATA =
      (SID = tcdbli)
    )
  )

# True Cache database application service name

sales_tc =
  (DESCRIPTION =
    (ADDRESS_LIST =
      (ADDRESS = (PROTOCOL = TCP)(HOST = true_cache_host)(PORT = 1521))
    )
    (CONNECT_DATA =
      (SERVICE_NAME = sales_tc)
    )
  )

# Primary database network name
```

```

primdbli =
  (DESCRIPTION =
    (ADDRESS_LIST =
      (ADDRESS = (PROTOCOL = TCP)(HOST = primary_database_host)(PORT = 1521))
    )
    (CONNECT_DATA =
      (SID = primdbli)
    )
  )

# Primary database application service name

sales =
  (DESCRIPTION =
    (ADDRESS_LIST =
      (ADDRESS = (PROTOCOL = TCP)(HOST = primary_database_host)(PORT = 1521))
    )
    (CONNECT_DATA =
      (SERVICE_NAME = sales)
    )
  )

listener_primary =
  (DESCRIPTION =
    (ADDRESS = (PROTOCOL = TCP)(HOST = primary_database_host)(PORT=1521))
  )

listener_true_cache =
  (DESCRIPTION =
    (ADDRESS = (PROTOCOL = TCP)(HOST = true_cache_host)(PORT=1521))
  )

```

2.3.2.2 Configure and Start the Local Listener on the True Cache Node

Configure and start the local listener to enable the True Cache node to receive redo from the primary database.

1. Create the `listener.ora` file manually or by using NETCA.

Here's an example of `listener.ora` on a True Cache node:

```

SID_LIST_LISTENER =
  (SID_LIST =
    (SID_DESC =
      (GLOBAL_DBNAME = tcdbli)
      (ORACLE_HOME = local_oracle_home_on_true_cache)
      (SID_NAME = tcdbli)
    )
  )

LISTENER =
  (DESCRIPTION =

```

```
(ADDRESS = (PROTOCOL = TCP)(HOST = true_cache_host)(PORT = 1521))  
)
```

2. In a command window, ensure that the `ORACLE_HOME` and `ORACLE_SID` environment variables are set properly.
3. Ensure that the `$ORACLE_HOME/bin` directory is in your `PATH` environment variable.
4. Start the listener and verify that it started correctly.

```
lsnrctl start  
lsnrctl status
```

2.3.2.3 Copy the Password File or Wallet from the Primary Database to the True Cache Node

To provide authentication for redo transport sessions, copy the primary database's password file or wallet to the True Cache node.

True Cache uses Oracle Net to transport redo data and control messages between the members of a True Cache configuration. These redo transport sessions are authenticated using a password file, so every True Cache in the configuration needs an up-to-date copy of the password file from the primary database.

Copy the primary database's password file to the appropriate directory on the True Cache node. You can find the password file in the `V$PASSWORDFILE_INFO` view, and on Linux the file is usually in `$ORACLE_HOME/dbs/orapwSID`.

In the examples in this documentation, the primary database's password file is `$ORACLE_HOME/dbs/orapwprimdbli` and would be copied to a True Cache node and renamed to `$ORACLE_HOME/dbs/orapwtdbli`.

If True Cache is down when the SYS password changes on the primary database, you might need to copy the password file to True Cache again when it comes back up.

Copy the wallet instead of the password file in the following situations:

- If the primary database uses TLS certificate authentication instead of a password file.
- If the primary database configures Transparent Data Encryption (TDE). Include only the `ROOT` container's master key in the copy for True Cache, which is used to decrypt encrypted redo that's shipped from the primary database.

Note

When using a TDE wallet, Oracle recommends configuring an auto-login or local auto-login wallet for True Cache. For auto-login wallets, you can create the wallet on the primary database and copy both the password wallet (`ewallet.p12`) and auto-login wallet (`cwallet.sso`) to True Cache. Local auto-login wallets are host-specific, so you can't copy them to another node. Instead, for local auto-login wallets, copy the password wallet to True Cache, open it on True Cache, and create the local auto-login wallet there with the wallet password. The local auto-login wallet offers more security because it prevents someone from copying both wallets and using them without knowing the wallet password. To learn more about wallet types, see [About Oracle AI Database Wallets](#).

2.3.2.4 Prepare a PFILE for True Cache

For each True Cache, prepare a PFILE with the following parameters.

Table 2-3 Initialization Parameters

Parameter	Description
TRUE_CACHE=TRUE	This tells the server that this is a True Cache.
DB_NAME	Enter the same value as the one for the primary database.
DB_UNIQUE_NAME	Specify a unique name for this True Cache.
DB_FILES	Enter the same value as the one for the primary database.
SGA_TARGET	Enter the SGA memory size of this True Cache.
REMOTE_LISTENER	Enter the primary database listener. This is not needed for the CREATE TRUE CACHE command, but it's needed to use JDBC. Note: For Oracle RAC primary databases, set the REMOTE_LISTENER parameter to SCAN:port. Note: Check to see if Valid Node Checking for Registration (VNCR) is configured for the listener. If so, add True Cache to the REGISTRATION_INVITED_NODES_LISTENER parameter in the listener.ora file of the remote listener. (In the example following this table, this is the primary database's listener.ora file.) Note: To simplify configuration and avoid connection issues, you can use the LISTENER_NETWORKS parameter instead of specifying REMOTE_LISTENER and LOCAL_LISTENER separately. All listeners within the same network_name will cross-register. For example: <pre>LISTENER_NETWORKS='((NAME=network_name) (LOCAL_LISTENER=(DESCRIPTION=(ADDRESS=(PROTOCOL=TCP)(HOST=true_cache_host) (PORT=1521)))) (REMOTE_LISTENER=primary_database_host:1521))'</pre>

For more information, see [Best Practices for Load Balancing in a Uniform Configuration](#).

Table 2-3 (Cont.) Initialization Parameters

Parameter	Description
FAL_SERVER	<p>Enter the network name for the primary database.</p> <p>Note: For Oracle RAC primary databases, set the FAL_SERVER parameter to SCAN:port/service_name.</p> <p>If you have standby databases that could become a primary after a primary-standby switchover, True Cache automatically adds the existing standby databases to the FAL_SERVER list. However, if you add a new standby database after configuring True Cache, you need to append the new standby database to the FAL_SERVER parameter for True Cache. To do this, use the following command with a comma-separated list of databases:</p> <pre>ALTER SYSTEM SET FAL_SERVER='existing_databases,new_standby_database' SCOPE=BOTH</pre>
FAL_CLIENT	<p>Enter the True Cache network name. When you start True Cache, it automatically adds that network name to the corresponding primary database LOG_ARCHIVE_DEST_n initialization parameter so that the primary database knows where to send online redo log blocks.</p>
DB_CREATE_FILE_DEST	<p>Enter a directory to store the internal True Cache files (for example, control files and temp files).</p> <p>If True Cache uses Oracle Automatic Storage Management (ASM) storage or Oracle Exadata Exascale Storage Vault, prefix the path with the ASM disk group or Exascale Vault name.</p> <p>Note: Make sure the directory has enough space to hold the temporary files in the primary database plus four times the maximum online redo log size per block size and per thread. For example, if the primary has two redo log threads and each thread has two 2GB online redo logs with 512-byte blocks, two 4GB online redo logs with 512-byte blocks, and three 8GB online redo logs with 4KB blocks, use the following formula: 2 threads x ((4GB x 2, for the biggest of the 512-byte blocks) + (8KB x 3, for the 4KB blocks)).</p>
DB_DOMAIN	<p>This might be necessary if the primary database also sets DB_DOMAIN. Set this to the domain where the True Cache node resides.</p>
WALLET_ROOT and TDE_CONFIGURATION	<p>If the primary database configures TDE with the recommended WALLET_ROOT and TDE_CONFIGURATION parameters, configure them accordingly on this True Cache.</p>

For example, the following PFILE is named `init_tcdbli.ora` and stored in the `$ORACLE_HOME/dbs/` directory on the True Cache node:

```

true_cache=true
db_name=primaryd
db_unique_name=tcdbli
db_files=200
sga_target=20G
fal_server=primdbli
fal_client=tcdbli
instance_name=tcdbli
db_create_file_dest=local_directory_on_true_cache_node
local_listener=listener
remote_listener=listener_primary

```

The preceding example assumes that the primary database's `DB_UNIQUE_NAME` initialization parameter is set to `primarydb` and `DB_FILES` is set to 200.

Related Topics

- [TRUE_CACHE](#)
- [Initialization Parameters](#)

2.3.2.5 Create and Start True Cache

Follow these steps to create and start True Cache for the first time.

1. Start up True Cache in `NOMOUNT` mode using `SQL*Plus`.

```
export ORACLE_SID=tcdbli
```

```
sqlplus / as SYSDBA
```

```
STARTUP NOMOUNT PFILE=$ORACLE_HOME/dbs/init_tcdbli.ora;
```

2. Verify that the password file points to the right file.

```
SELECT file_name FROM v$passwordfile_info;
```

```
FILE_NAME
```

```
-----  
/u01/example/oracle/product/main/db_1/dbs/orapwtcdbli
```

3. Create and start True Cache.

```
CREATE TRUE CACHE;
```

4. To verify that True Cache is working, see [Verifying That True Cache Is Working as Expected](#).

When you create True Cache, it automatically creates standby redo logs with the appropriate size, control files, temp files (when needed), and an internal `SPFILE` based on the first `PFILE` that you created. This `SPFILE` is used automatically on later `STARTUP` commands without the need to specify any `PFILE` values.

At this point, your applications can use separate physical connections to the primary database and True Cache and choose which connection to use based on whether it's reading or writing.

To use True Cache with the JDBC Thin driver, continue to the next topic to configure the database application services for True Cache.

2.3.3 Configuring True Cache Database Application Services Manually

To use True Cache with the JDBC Thin driver, for each primary database application service that you want to cache, create a corresponding True Cache database application service.

This makes it easy for applications to switch an existing JDBC connection from a primary database to True Cache without having to change the JDBC connection URL. This is possible with the 26ai JDBC Thin driver by setting the `ReadOnly` parameter of the connection to `TRUE` or `FALSE`.

2.3.3.1 Create Database Application Services on the Primary Database

You can associate one primary database service with one True Cache service.

From the primary database, create or modify the True Cache and primary database services using one of the following methods.

True Cache and Single Instance Primary Databases

For True Cache and single instance primary databases, use the `DBMS_SERVICE` PL/SQL package. For services that are specific to a pluggable database (PDB), connect to the specific PDB, or set the correct PDB container in your session before starting the service using `DBMS_SERVICE`.

Here's an example of creating these two services using the `DBMS_SERVICE` package for a single instance primary database:

```
DECLARE
    db_params dbms_service.svc_parameter_array;
BEGIN
    -- create a database application service for True Cache called SALES_TC
    using SALES_TC tnsname
    DBMS_SERVICE.CREATE_SERVICE('SALES_TC', 'SALES_TC', db_params);

    -- create a database application service SALES for primary database using
    SALES tnsname and associate it to the SALES_TC service name using
    TRUE_CACHE_SERVICE attribute
    db_params('true_cache_service') := 'SALES_TC';
    DBMS_SERVICE.CREATE_SERVICE('SALES', 'SALES', db_params);

    -- or, modify an already existing primary database application service
    called SALES to associate it to the SALES_TC service name using the
    TRUE_CACHE_SERVICE attribute
    db_params('true_cache_service') := 'SALES_TC';
    DBMS_SERVICE.MODIFY_SERVICE('SALES', db_params);

END;
```

Oracle RAC Primary Databases

For Oracle RAC primary databases, use the `srvctl` command line utility to add the services. Start the service on the primary instance. Use `srvctl` only for Oracle Clusterware-managed instances.

To create both a True Cache service and the primary database service:

```
srvctl add service -db primary_db_unique_name -service  
true_cache_service_name -preferred primary_db_instance_list -pdb  
primary_pdb_name
```

```
srvctl add service -db primary_db_unique_name -service  
primary_db_service_name -preferred primary_db_instance_list -pdb  
primary_pdb_name -true_cache_service true_cache_service_name
```

For example:

```
srvctl add service -db primdbli -service sales_tc -preferred  
primdbli1,primdbli2 -pdb sales_pdb  
srvctl add service -db primdbli -service sales -preferred primdbli1,primdbli2  
-pdb sales_pdb -true_cache_service sales_tc
```

To create a True Cache service for an existing primary database service (`db_service_name`):

```
srvctl add service -db primary_db_unique_name -service  
true_cache_service_name -preferred primary_db_instance_list -pdb  
primary_pdb_name
```

```
srvctl modify service -db primary_db_unique_name -service  
primary_db_service_name -true_cache_service true_cache_service_name
```

For example:

```
srvctl add service -db primdbli -service sales_tc -preferred  
primdbli1,primdbli2 -pdb sales_pdb  
srvctl modify service -db primdbli -service sales -true_cache_service sales_tc
```

Note

Also disable the True Cache service on the cluster where it was added to prevent errors when stopping and restarting the primary database services. For example:

```
srvctl start service -d primdbli -s sales_tc
```

```
srvctl stop service -d primdbli -s sales_tc
```

```
srvctl disable service -d primdbli -s sales_tc
```

This doesn't affect standby databases or True Caches because they run outside the cluster where the True Cache service is disabled. The disabled status is not stored in the primary dictionary and `DBA_SERVICES`, but only in Cluster Ready Services (CRS), and only in the cluster where the True Cache service was added. Other databases outside the cluster can start the service with `DBMS_SERVICE.START_SERVICE` and aren't affected by this setting.

Related Topics

- [CREATE_SERVICE Procedure](#)
- [MODIFY_SERVICE Procedure](#)
- [Server Control Utility Reference](#)

2.3.3.2 Verify That the Database Application Services Are Created

After you create services on the primary database, True Cache automatically inherits their definitions. Using SQL*Plus, make sure that you can see the same results on both the primary database and True Cache.

For example:

```
connect / as SYSDBA
```

```
SELECT name, true_cache_service FROM DBA_SERVICES WHERE name='SALES' or
name='SALES_TC' ;
```

NAME	TRUE_CACHE_SERVICE
-----	-----
SALES_TC	
SALES	SALES_TC

2.3.3.3 Start the Database Application Services

Using SQL*Plus, start the database application services on both the primary database and True Cache. For services that are specific to a pluggable database (PDB), connect to the specific PDB, or set the correct PDB container in your session before starting the service using `DBMS_SERVICE`.

Example 2-1 True Cache

```

connect / as SYSDBA

SELECT database_role FROM v$databases;

DATABASE_ROLE
-----
TRUE CACHE

ALTER SESSION SET CONTAINER=pdb_name;

EXEC DBMS_SERVICE.START_SERVICE('SALES_TC');

SELECT service_id, name FROM v$active_services WHERE name='SALES_TC';

SERVICE_ID  NAME
-----  -----
          28  SALES_TC

```

Example 2-2 Primary Database

```

connect / as SYSDBA

SELECT database_role FROM v$databases;

DATABASE_ROLE
-----
PRIMARY

ALTER SESSION SET CONTAINER=pdb_name;

EXEC DBMS_SERVICE.START_SERVICE('SALES');

SELECT service_id, name, true_cache_service FROM v$active_services WHERE
name='SALES';

SERVICE_ID  NAME      TRUE_CACHE_SERVICE
-----  -----  -----
          29  SALES    SALES_TC

```

Related Topics

- [Verify That the Database Application Services Are Created](#)
After you create services on the primary database, True Cache automatically inherits their definitions. Using SQL*Plus, make sure that you can see the same results on both the primary database and True Cache.

- [START_SERVICE Procedure](#)
- [V\\$ACTIVE_SERVICES](#)
- [V\\$DATABASE](#)

2.4 Deploying True Cache for an Oracle RAC Primary Database

This section summarizes the configuration requirements for deploying True Cache for a primary database in an Oracle Real Application Clusters (Oracle RAC) environment. These requirements are also included in context within the detailed configuration steps.

Note

All of this information also appears in the context of the configuration steps for [Configuring True Cache with DBCA](#) and [Configuring True Cache Manually](#).

- True Cache needs to be able to access each instance in the Oracle RAC environment. To do this, use the single client access name (SCAN) listener when configuring True Cache.
 - If you're configuring True Cache with DBCA, set the `-sourceDBConnectionString` parameter to `SCAN:port/service_name`.
 - If you're manually configuring True Cache, use the following settings when preparing the `PFILE` for True Cache:
 - * Set the `REMOTE_LISTENER` parameter to `SCAN:port`.
 - * Set the `FAL_SERVER` parameter to `SCAN:port/service_name`.
 - Add the True Cache node to the invited node list for the SCAN listener by using the `srvctl` command line utility. (Don't manually edit the `listener.ora` file as the grid owner user.)

For example:

```
srvctl modify scan_listener -invitednodes true_cache_host -endpoints
TCP:port
```

- When creating the database application services on the primary database, use the `srvctl` command line utility to add the services. Start the service on the primary instance. Use `srvctl only` for Oracle Clusterware-managed instances.

To create both a True Cache service and the primary database service:

```
srvctl add service -db primary_db_unique_name -service
true_cache_service_name -preferred primary_db_instance_list -pdb
primary_pdb_name
```

```
srvctl add service -db primary_db_unique_name -service
primary_db_service_name -preferred primary_db_instance_list -pdb
primary_pdb_name -true_cache_service true_cache_service_name
```

For example:

```
srvctl add service -db primdbli -service sales_tc -preferred  
primdbli1,primdbli2 -pdb sales_pdb  
srvctl add service -db primdbli -service sales -preferred  
primdbli1,primdbli2 -pdb sales_pdb -true_cache_service sales_tc
```

To create a True Cache service for an existing primary database service
(*db_service_name*):

```
srvctl add service -db primary_db_unique_name -service  
true_cache_service_name -preferred primary_db_instance_list -pdb  
primary_pdb_name
```

```
srvctl modify service -db primary_db_unique_name -service  
primary_db_service_name -true_cache_service true_cache_service_name
```

For example:

```
srvctl add service -db primdbli -service sales_tc -preferred  
primdbli1,primdbli2 -pdb sales_pdb  
srvctl modify service -db primdbli -service sales -true_cache_service  
sales_tc
```

Note

Also disable the True Cache service on the cluster where it was added to prevent errors when stopping and restarting the primary database services. For example:

```
srvctl start service -d primdbli -s sales_tc
```

```
srvctl stop service -d primdbli -s sales_tc
```

```
srvctl disable service -d primdbli -s sales_tc
```

This doesn't affect standby databases or True Caches because they run outside the cluster where the True Cache service is disabled. The disabled status is not stored in the primary dictionary and `DBA_SERVICES`, but only in Cluster Ready Services (CRS), and only in the cluster where the True Cache service was added. Other databases outside the cluster can start the service with `DBMS_SERVICE.START_SERVICE` and aren't affected by this setting.

Related Topics

- [srvctl modify scan listener](#)

2.5 Verifying the True Cache Configuration

Verify that True Cache and the database application services are working as expected.

2.5.1 Verifying That True Cache Is Working as Expected

To verify that True Cache is applying redo and making progress, check the following queries on True Cache.

1. Run SQL*Plus on the True Cache.

```
sqlplus / as SYSDBA
```

2. Enter the following query:

```
SELECT database_role, open_mode FROM v$database;
```

The output should look like this:

```
DATABASE_ROLE      OPEN_MODE
-----
TRUE CACHE         READ ONLY WITH APPLY
```

If OPEN_MODE is READ ONLY WITH APPLY, it means that the True Cache redo apply is actively working.

3. Enter the following query multiple times:

```
SELECT current_scn FROM v$database;
```

If CURRENT_SCN is advancing over time, it means that True Cache is moving forward as expected.

4. To find the size of each log file, enter the following query:

```
SELECT THREAD#, SEQUENCE#, BYTES FROM v$standby_log;
```

2.5.2 Verifying the Remote Listener Configuration

After the database application service starts on True Cache, use the `lsnrctl` command to validate the remote listener services for the True Cache service registration.

Note

For Oracle RAC primary databases, before using the `lsnrctl` command, set your `$ORACLE_HOME` environment variable to the path for the Oracle Grid Infrastructure home (Grid home).

The following example shows two True Caches registered with the SCAN listener for an Oracle RAC primary database:

```
lsnrctl services LISTENER_SCAN1

Service "sales_tc" has 2 instance(s).
  Instance "tcdb1", status READY, has 1 handler(s) for this service...
    Handler(s):
      "DEDICATED" established:0 refused:0 state:ready
      REMOTE SERVER
      (DESCRIPTION=(ADDRESS=(PROTOCOL=TCP)(HOST=tc1.example.com)
(PORT=1521)))
  Instance "tcdb2", status READY, has 1 handler(s) for this service...
    Handler(s):
      "DEDICATED" established:0 refused:0 state:ready
      REMOTE SERVER
      (ADDRESS=(PROTOCOL=TCP)(HOST=tc2.example.com)(PORT=1521))
```

Note

If the True Cache service is not registered with the remote listener, validate the remote listener invited nodes and the True Cache initialization parameters for `REMOTE_LISTENER` or `LISTENER_NETWORKS`.

2.5.3 Verifying the True Cache and Primary Database Application Services

Verify that all database application services are active on both the primary database and True Cache.

True Cache

1. Run SQL*Plus on True Cache.

```
sqlplus / as SYSDBA
```

2. Enter the following query:

```
SELECT service_id,name FROM v$active_services WHERE
name='true_cache_service_name';
```

For example:

```
SELECT service_id, name FROM v$active_services WHERE name='SALES_TC';
```

```
SERVICE_ID  NAME
-----  -----
          28  SALES_TC
```

Primary Database

1. Run SQL*Plus on the primary database.

```
sqlplus / as SYSDBA
```

2. Enter the following query:

```
SELECT service_id, name, true_cache_service FROM v$active_services WHERE
name='primary_db_service_name';
```

For example:

```
SELECT service_id, name, true_cache_service FROM v$active_services WHERE
name='SALES';
```

SERVICE_ID	NAME	TRUE_CACHE_SERVICE
29	SALES	SALES_TC

Related Topics

- [Configuring True Cache Database Application Services Manually](#)
To use True Cache with the JDBC Thin driver, for each primary database application service that you want to cache, create a corresponding True Cache database application service.
- [V\\$ACTIVE_SERVICES](#)

2.6 Enabling DML Redirection

True Cache is a read-only cache, so you can't directly update the cache, but you can use DML redirection to indirectly update the cache.

DML redirection writes data to the primary database and then that data is automatically updated in the cache. This is similar to how Oracle Active Data Guard works. Because DML redirection uses more resources, it's not recommended for update-intensive applications.

To enable and use DML redirection, set the `ADG_REDIRECT_DML` initialization parameter to `TRUE` on True Cache.

Note

If the user logs in to True Cache with OS authentication, the user can't enable `ADG_REDIRECT_DML`. This is because the True Cache database administrator might not actually have the `SYSDBA` password but is allowed to use OS authentication to manage True Cache as `SYSDBA`. If the user can set `ADG_REDIRECT_DML`, then that user can update primary data as `SYSDBA` without knowing the `SYSDBA` password.

For more on enabling DML redirection, see [Managing Physical and Snapshot Standby Databases](#).

3

Deploying True Cache on Oracle Base Database Service

You can deploy True Cache on Oracle Base Database Service to run True Cache on virtual machines (VMs) in Oracle Cloud Infrastructure (OCI).

The following process creates the True Cache node on Oracle Base Database Service and configures True Cache using DBCA with the password file in a configuration BLOB file.

For other True Cache configuration options, see [Configuring True Cache](#).

1. Provision a database system (DB system) to use as the True Cache node.

For storage, select the **Logical Volume Manager** option.

For details, see [Overview of Creating a DB System](#).

2. Open port 1521 between the primary database and the True Cache node.

For details, see [Overview of Connecting to a DB System](#).

3. Delete the database that was created on the True Cache node in step 1.

Run the following command as the `oracle` user on the True Cache node:

```
$ORACLE_HOME/bin/dbca -deleteDatabase -sourceDB true_cache_sid -  
forceArchiveLogDeletion - silent
```

Example:

```
$ORACLE_HOME/bin/dbca -deleteDatabase -sourceDB DBD -  
forceArchiveLogDeletion -silent
```

4. Create True Cache.

For details, see [Creating True Cache with DBCA](#).

5. Create the True Cache service.

For details, see [Configuring True Cache Database Application Services with DBCA](#).

4

Deploying True Cache in Containers

Containers can simplify the deployment of True Cache configurations.

You can use the scripts that are provided in the True Cache container image to automatically create a True Cache configuration. The scripts complete the following configuration tasks:

- Create the primary database and True Cache containers.
- Create and start True Cache.
- Create and start the database application services for the primary database and True Cache.

See the complete instructions for downloading the images and creating the containers in the [Oracle AI Database Container Images README.md](#).

Create a separate container for each True Cache. Assign different container names, Oracle SIDs, and database application service names, as needed.

5

Shutting Down and Starting True Cache

You can shut down and start an existing True Cache.

Note

Perform these tasks on the True Cache container database (CDB), not on the pluggable database (PDB).

5.1 Shutting Down True Cache

To shut down True Cache, use the `SHUTDOWN` command.

Note

Before shutting down True Cache for planned maintenance, stop the database application service on True Cache.

```
connect / as SYSDBA;
```

```
SHUTDOWN;
```

When you shut down True Cache, the cached content is lost. When you restart True Cache, it fetches the content again from the primary database.

5.2 Starting True Cache

To start an existing True Cache, use the `STARTUP` command.

```
connect / as SYSDBA;
```

```
STARTUP;
```

Work is automatically routed to True Cache when it declares that it's ready to support the True Cache service.

6

Monitoring True Cache

You can monitor True Cache with the `V$TRUE_CACHE` view, Oracle Enterprise Manager, and the Automatic Workload Repository (AWR).

6.1 Monitoring True Cache with the `V$TRUE_CACHE` View

Use the `V$TRUE_CACHE` view to monitor the overall relationship and health of a True Cache configuration.

You can query the `V$TRUE_CACHE` view on the primary database and True Cache. On True Cache, the view displays a single row for the primary database that it connects to. On the primary database, the view shows one row for each True Cache that's connected to the primary database. Each row displays the status for the True Cache.

To use this view, enter the following query:

```
SELECT * FROM v$true_cache;
```

The following example shows output on True Cache:

MY_DG_ID	REMOTE_DG_ID	DEST_ID	TRUE_CACHE_NAME	PRIMARY_NAME	STATUS
REMOTE_VERSION	CON_ID				
2976625076	626116455	0	TCDB1	PRIMARYD	HEALTHY
23.0.0.0.0	0				

The following example shows output on a primary database:

MY_DG_ID	REMOTE_DG_ID	DEST_ID	TRUE_CACHE_NAME	PRIMARY_NAME	STATUS
REMOTE_VERSION	CON_ID				
626116455	2976625076	2	TCDB1	PRIMARYD	HEALTHY
23.0.0.0.0	0				
626116455	2499211322	3	TCDB2	PRIMARYD	HEALTHY
23.0.0.0.0	0				

6.1.1 V\$TRUE_CACHE Columns

The following table describes the columns in the V\$TRUE_CACHE view.

Table 6-1 V\$TRUE_CACHE Columns

Column	Datatype	Description
MY_DG_ID	NUMBER	The Data Guard ID (DGID) that uniquely identifies the True Cache or primary database in the True Cache configuration
REMOTE_DG_ID	NUMBER	On True Cache, this is the primary database's DGID. On the primary database, it's the True Cache DGID.
DEST_ID	NUMBER	On True Cache, this is always 0. On the primary database, it's the corresponding destination ID (<i>n</i>) of the LOG_ARCHIVE_DEST_ <i>n</i> initialization parameter. The LOG_ARCHIVE_DEST_ <i>n</i> initialization parameter specifies the network name of the True Cache so that the primary database knows where to send online redo log blocks.
TRUE_CACHE_NAME	VARCHAR2(30)	The unique name of the True Cache (DB_UNIQUE_NAME in the PFILE)
PRIMARY_NAME	VARCHAR2(30)	The unique name of the primary database (DB_UNIQUE_NAME in the PFILE)
STATUS	VARCHAR2(256)	Describes the current status of the True Cache. If no issues are found, it displays HEALTHY. Otherwise, it displays an error description. For example: ORA-01034: The Oracle instance is not available for use. Start the instance.
REMOTE_VERSION	VARCHAR2(18)	On True Cache, this is the database version of the primary database. On the primary database, this is the database version of the True Cache.
CURRENT_SCN	NUMBER	On True Cache, this is the SCN of the primary database from the last time the True Cache SCN was refreshed. On the primary database, this is the SCN of the True Cache.
CON_ID	NUMBER	The root container ID

Related Topics

- [V\\$TRUE_CACHE](#)

6.2 Monitoring True Cache with the V\$TRUE_CACHE_STAT View

Use the V\$TRUE_CACHE_STAT view to monitor True Cache statistics, including apply lag, transport lag, and block fetch latency.

Query V\$TRUE_CACHE_STAT on True Cache. On the primary database this query returns no rows.

To use this view, enter the following query:

```
SELECT * FROM v$true_cache_stat;
```

The following example shows output:

```

MY_DGID      REMOTE_DGID  DEST_ID NAME                                VALUE
UNIT                                                DATA_TIME      CON_ID
-----
3767970343  4224862145      0 single block fetch latency  3091
micro seconds per block  04/23/2025 21:12:10                                0
3767970343  4224862145      0 multiblock fetch latency   3432
micro seconds per request 04/23/2025 21:12:10                                0
3767970343  4224862145      0 list of blocks fetch latency 3663
micro seconds per request 04/23/2025 21:12:10                                0
3767970343  4224862145      0 prewarm progress           28.35
percentage completed      04/23/2025 21:12:10                                0
transport lag              +00 00:00:00
day(2) to second(0) interval 04/23/2025 21:12:10 04/23/2025 21:12:09 0
apply lag                  +00 00:00:00
day(2) to second(0) interval 04/23/2025 21:12:10 04/23/2025 21:12:09 0
apply finish time
day(2) to second(3) interval 04/23/2025 21:12:10                                0
estimated startup time
second                      04/23/2025 21:12:10                                0

```

6.2.1 V\$TRUE_CACHE_STAT Columns

The following table describes the columns in the V\$TRUE_CACHE_STAT view.

Column	Datatype	Description
MY_DGID	NUMBER	Data Guard hash ID for True Cache
REMOTE_DGID	NUMBER	Data Guard hash ID for the primary database
DEST_ID	NUMBER	Log archive destination parameter identifier The value of this column is always 0.

Column	Datatype	Description
NAME	VARCHAR2(32)	<p>Name of the metric:</p> <ul style="list-style-type: none"> apply lag - Apply lag is a measure of the degree to which the data in True Cache lags behind the data in the primary database, due to delays in propagating and applying redo to True Cache. list of blocks fetch latency - The average latency of True Cache while fetching blocks from the primary database in list of blocks fetch mode. multiblock fetch latency - The average latency of True Cache while fetching blocks from the primary database in multiblock fetch mode. prewarm progress - The current progress of True Cache prewarming its own buffer cache by proactively fetching the list of blocks remembered from the last warmed up state, that is, from the previous instance lifetime. single block fetch latency - The average latency of True Cache while fetching blocks from the primary database in single block fetch mode. transport lag - Transport lag is a measure of the degree to which the transport of redo to True Cache lags behind the generation of redo on the primary database. If there are one or more redo gaps on True Cache, the transport lag is calculated as if no redo has been received after the beginning of the earliest redo gap. <p>Note: The apply finish time and estimated startup time metrics are not meaningful on a True Cache and can be ignored.</p>
VALUE	VARCHAR2(64)	Value of the metric
UNIT	VARCHAR2(32)	Unit of measurement
TIME_COMPUTED	VARCHAR2(32)	Local time on True Cache when the metric was computed
DATA_TIME	VARCHAR2(32)	<p>Local time on True Cache when the data used to compute the metric was received</p> <p>The apply lag and transport lag metrics are computed based on data that is periodically received from the primary database. An unchanging value in this column across multiple queries indicates that True Cache is not receiving data from the primary database.</p>
CON_ID	NUMBER	<p>The ID of the container to which the data pertains.</p> <p>The value of this column is always 0 (CDB\$ROOT container).</p>

Related Topics

- [V\\$TRUE_CACHE_STAT](#)

6.3 Using the Automatic Workload Repository for True Cache

You can use the Automatic Workload Repository (AWR) to gather performance statistics for True Cache.

AWR snapshots for True Cache are enabled by default. Snapshots are automatically captured hourly.

You can also manually create a snapshot. For example:

```
// Create snapshots (snap_id 0 means failure)
SELECT DBMS_WORKLOAD_REPOSITORY.CREATE_SNAPSHOT FROM dual;
```

To generate an AWR snapshot report, complete the following steps on either the primary database or the True Cache:

1. Go to the `$ORACLE_HOME` directory and run the following script:

- On True Cache:

```
@?/rdbms/admin/awrrpt.sql
```

- On the primary database:

```
@?/rdbms/admin/awrrpti.sql
```

2. Specify whether you want an HTML or a text report. For example:

```
Enter value for report_type: text
```

The output displays a list of available database identifiers and instance numbers.

3. If you're generating the report on the primary database, enter the database identifier (dbid) and instance number (inst_num) for True Cache. For example:

```
Enter value for dbid: 3309173529
Using 3309173529 for database Id
Enter value for inst_num: 1
```

To get the dbid for True Cache, run the following query on the True Cache:

```
SELECT DBMS_WORKLOAD_REPOSITORY.GET_AWR_ID() FROM dual;
```

This step is not required if you're generating the report on True Cache because the `awrrpt.sql` script automatically derives the dbid of the local node.

4. Specify the number of days for which you want to list snapshot IDs. For example:

```
Enter value for num_days: 2
```

The output displays a list of existing snapshots for the specified time range.

5. Specify beginning and ending snapshot IDs for the workload repository report. For example:

```
Enter value for begin_snap: 150
Enter value for end_snap: 160
```

6. Enter a report name or accept the default report name. For example:

```
Enter value for report_name:
Using the report name awrrpt_1_150_160
```

Related Topics

- [Automatic Workload Repository \(AWR\)](#)
- [Managing Snapshots](#)

- [Generating an AWR Report Using the Command-Line Interface](#)
- [DBMS_WORKLOAD_REPOSITORY](#)

6.4 Monitoring True Cache with Oracle Enterprise Manager

You can discover, monitor, and manage Oracle True Cache in Oracle Enterprise Manager.

Discovery

True Caches can be discovered in Enterprise Manager manually or using Auto Discovery. For details, see [Discovering and Adding True Cache](#) in *Oracle Enterprise Manager Monitoring Guide*.

Monitoring

Once the primary database and True Caches are discovered and added, you can use Enterprise Manager to monitor their health and performance. If you have configured multiple True Caches for a single primary (a one-to-many setup), you can use Enterprise Manager to view the topology and obtain a comprehensive overview of the primary database and all its associated True Caches. From the **Configuration Topology** view, you can navigate to the Home page of a True Cache to view graphs that display transport lag, apply lag, and hit ratios. This lets you assess how current and efficient the cache is.

Metrics

Enterprise Manager provides standard database performance and usage metrics and key True Cache-specific metrics. True Cache metrics in Enterprise Manager include Database Load, Memory Usage, and True Cache Hit Ratios and Lags. Having these metrics readily available in the user interface enables you to quickly detect performance degradations and lag, and proactively fix issues. For details on the True Cache metrics in Enterprise Manager, see True Cache in *Oracle Enterprise Manager Oracle Database Metric Reference Manual*.

Performance Hub

Starting with Oracle Enterprise Manager 24ai Release 1 Update 7 (24.1.0.7), you can use Performance Hub in Enterprise Manager to monitor database activity, diagnose issues, and tune queries to improve True Cache performance.

You can use the following Performance Hub features with True Cache:

- **ASH Analytics:** Displays Active Session History (ASH) analytics charts that you can use to explore ASH data. In the **ASH Analytics** tab, you can select an Average Active Sessions dimension and view the top activity for that dimension for the selected time period.
- **SQL Monitoring:** Displays a table that lists monitored SQL statements by dimensions, such as **Last Active Time**, **CPU Time**, **Database Time**, and so on. The **SQL Monitoring** tab provides information about SQL statements that are currently running and SQL statements that completed, failed, or were terminated.
- **SQL History:** Provides granular statistics on all the SQL executions in the database. The table in the **SQL History** tab displays the top 500 executions by completion time along with information such as status, session ID, completion time, duration, SQL ID, SQL plan hash, user name, service, module, action, parallel execution, database time, and SQL text.

For details, see Using Performance Hub to Analyze Database Performance in *Oracle AI Database Performance Tuning Guide*.

7

Using Oracle True Cache in Your Applications

When True Cache is configured, applications must decide whether to query data from True Cache or the primary database.

7.1 Methods for Connecting to True Cache

Applications can use True Cache in the several ways.

- **Two physical connections**

The application maintains two physical connections: one to the primary database and one to True Cache. Each connection has a database application service, and the application chooses which connection to use based on whether it's reading or writing. You can use this model with any existing client drivers and any programming language.

The application sends queries that don't need to see the most current data to True Cache through a True Cache database application service. The application sends other queries and updates to the primary database through the primary database application service.

- **One logical connection (JDBC Thin driver)**

The application maintains one logical connection that uses the database application service for the primary database. The JDBC Thin driver (starting with Oracle AI Database 26ai) maintains physical connections to the primary database and True Cache. This model only works with Java applications.

The application switches between the primary database and True Cache without having to specify an instance name. The application uses special calls to flag the logical connection as read-only or read-write. If it's read-only, the query is sent to True Cache. Otherwise, it's sent to the primary database.

To enable the True Cache functionality for Java applications, set the value of the `oracle.jdbc.useTrueCacheDriverConnection` property to `true`. After you enable True Cache, the JDBC Thin driver uses the standard `java.sql.Connection.setReadOnly(boolean)` and `java.sql.Connection.isReadOnly()` methods to mark a connection as read-only. By default, the read-only mode is `false` for a connection.

- **Single Oracle Call Interface (OCI) session pool**

Starting with Oracle AI Database 26ai, Release Update 23.26.0, you can use a single OCI session pool to manage connections to both a primary database and True Cache.

The application can either request a session from the primary database (default) or explicitly request a read-only session from True Cache. There's also an option to prefer True Cache, if available, and otherwise fall back to the primary database.

To enable session pooling for True Cache, initialize the session pool in multiple service pool mode by specifying the mode `OCI_SPC_TRUECACHE` for `OCISessionPoolCreate()`. To get read-only sessions from True Cache, use `OCISessionGet()` with `OCI_SESSGET_READ_ONLY` mode. To fall back to the primary database if no True Cache session is available, use `OCI_SESSGET_READ_PREFER` mode. If the mode is not specified, the session gets the connection from the primary database instance by default.

For details, see True Cache Session Pooling in *Oracle Call Interface Developer's Guide*.
See the following technical architecture diagram for details and examples:

[True Cache Application](#)

Related Topics

- [Support for Oracle True Cache](#)
- [setReadOnly\(boolean\) method](#)
- [isReadOnly\(\) method](#)

7.2 Sample Java Code Using the JDBC Thin Driver

The JDBC method is illustrated by the following Java code using the JDBC Thin driver.

Warning

Do not use this code in a production environment.

The core of this basic code is in the `test1` function, which does the following:

1. Creates a connection to the primary database by using the JDBC Thin driver with either a default user name and password or values that are specified on the command line when invoking the program.
2. Prints some basic information about the primary database connection to verify that the application is connected to the database.
3. Changes the `isReadOnly` connection parameter to `TRUE` to automatically switch the connection to True Cache and verify that it's connected to it.

```
import java.sql.*;
import java.io.*;
import java.util.*;
import java.util.logging.FileHandler;
import java.util.logging.Level;
import java.util.logging.Logger;

import oracle.jdbc.driver.OracleLog;
import oracle.jdbc.pool.OracleDataSource;

public class TrueCache {
    static String url_primary = "jdbc:oracle:thin:@primary_database_host:1521/
SALES";
    static String user = "username";
    static String password = "password";

    public static void main(String args[]) {
        try {
            TrueCache t = new TrueCache();
            if(args != null && args.length > 0 ) {
                url_primary = args[0];
                user = args[1];
                password = args[2];
            }
        }
    }
}
```

```

    }
    t.test1();
} catch (Exception e) {
    e.printStackTrace();
}
}

public void test1() throws SQLException {
    show("Basic test to connect to primary and True Cache");
    try {
        show("Get Connection from True Cache instance using primary db and
properties");
        OracleDataSource ods1 = new OracleDataSource();
        show("URL = " + url_primary);
        ods1.setURL(url_primary);
        ods1.setUser(user);
        ods1.setPassword(password);
        ods1.setConnectionProperty("oracle.jdbc.useTrueCacheDriverConnection",
"true");

        Connection conn1 = ods1.getConnection();

        show("isReadOnly " + conn1.isReadOnly());
        verifyConnection(conn1); // This is connected to Primary

        conn1.setReadOnly(true);
        show("isReadOnly " + conn1.isReadOnly());
        verifyConnection(conn1); // This is connected to True Cache

        conn1.close();
    } catch (SQLException sqex) {
        show("test1 -- failed" + sqex.getMessage()+":"+sqex.getCause());
        sqex.printStackTrace();
    }
    show("The end");
}

public void verifyConnection(Connection conn) {
    try {
        Statement statement = conn.createStatement();
        ResultSet rs = statement.executeQuery("SELECT database_role from
v$databases");
        ResultSetMetaData rsmd = rs.getMetaData();
        int columnsNumber = rsmd.getColumnCount();
        rs.next();
        show("Database role : " + rs.getString(1));
        rs.close();
        ResultSet resultSet = statement.executeQuery("SELECT
SYS_CONTEXT('userenv', 'instance_name') as instance_name"
+ ", SYS_CONTEXT('userenv', 'server_host')" + " as server_host" +
", SYS_CONTEXT('userenv', 'service_name')"
+ " as service_name" + ", SYS_CONTEXT('USERENV','db_unique_name')"
+ " as db_unique_name" + " from sys.dual");
        resultSet.next();
        show("instance_name : " + resultSet.getString("instance_name"));
        show("server_host : " + resultSet.getString("server_host"));
    }
}

```

```

        show("service_name : " + resultSet.getString("service_name"));
        show("db_unique_name : " + resultSet.getString("db_unique_name"));
        resultSet.close();
        statement.close();
    } catch (SQLException sqex) {
        show("verifyConnection failed " + sqex.getMessage());
    }
}

public void show(String msg) {
    System.out.println(msg);
}
}

```

7.3 Sample Java Code for Applications Using a Native Connection to the Database

The following Java code illustrates how to use True Cache with applications that use an object-relational mapping (ORM) framework.

This is another example of maintaining only one logical connection to a database application service running on the primary database and letting the driver handle the underlying physical connections. It shows how to get the underlying connections from the framework so you can set the necessary parameter.

Warning

Do not use this code in a production environment.

1. Add the `oracle.jdbc.useTrueCacheDriverConnection=true` connection property to the connection URL in the `persistence.xml` file.
2. In the methods that need to use a True Cache connection, unwrap the session, use the `doWork` method to retrieve the underlying JDBC connection, and set the necessary read-only parameter for the connection. For example:

```

Session session = em.unwrap(Session.class);
session.doWork(new Work() {

    @Override
    public void execute(Connection con) throws SQLException {
        // if it is connected to primary, I want the connection to switch to
        true_cache now
        if(!con.isReadOnly()) {
            // The below code demonstrates the connection is to primary
            now
            System.out.println("Query getting executed on:");
            Statement statement = con.createStatement();
            ResultSet rs = statement.executeQuery("SELECT database_role from
v$database");
            rs.next();
            System.out.println("Database role : " + rs.getString(1));
            rs.close();
        }
    }
}

```

```

        // Now switching the connections to true cache
        con.setReadOnly(true);
        // The below code demonstrates the connection is to true cache
now
        System.out.println("After set read only true, Query getting
executed on:");
        Statement statement2 = con.createStatement();
        ResultSet rs2 = null;

        rs2 = statement2.executeQuery("SELECT database_role from
v$database");
        rs2.next();
        System.out.println("Database role : " + rs2.getString(1));
        rs2.close()
    }
}
});

```

7.4 Best Practices for Load Balancing in a Uniform Configuration

If multiple True Caches exist and serve the same database application service, the listener automatically distributes and load balances sessions to each cache. In a uniform configuration, the listener picks a True Cache randomly or based on load, and all True Caches cache the same data.

A uniform configuration uses runtime connection load balancing (CLB), which routes requests to the True Cache that offers the best performance. For this to work, all True Caches' `REMOTE_LISTENER` parameters should point to the same listener, which is also the primary database's listener (whether it's single instance primary database's local listener or an Oracle RAC primary database's SCAN listener).

The application's JDBC URL should point to the primary database. Then the JDBC Thin driver creates one logical connection and multiple physical connections to the primary database and to each True Cache. Setting the `setReadOnly(true)` flag in the Java code reroutes connections to the True Caches automatically. The True Caches are registered with the primary database listener, and they also send their load statistics to the primary database listener. You should see an even distribution between True Caches.

To simplify configuration and avoid connection issues, consider using the `LISTENER_NETWORKS` initialization parameter instead of specifying `REMOTE_LISTENER` and `LOCAL_LISTENER` separately. With `LISTENER_NETWORKS`, all listeners within the same network name will cross-register. For example:

```

listener_networks='((NAME=net1)
(LOCAL_LISTENER=(DESCRIPTION=(ADDRESS=(PROTOCOL=TCP)(HOST=tc1.example.com)
(PORT=1521))))(REMOTE_LISTENER=scan_primary:1521))',
    '((NAME=net2)(LOCAL_LISTENER=(DESCRIPTION=(ADDRESS=(PROTOCOL=TCP)
(HOST=tc1.example.com)(PORT=1521))))(REMOTE_LISTENER=scan_standby:1521))'

```

For more about configuring remote listeners and listener networks, see [Prepare a PFILE for True Cache](#).

Related Topics

- [About Run-Time Connection Load Balancing](#)

8

Complementary Caching Features

True Cache can be combined with other Oracle AI Database features to improve performance.

8.1 Server-Side Result Set Cache

The server-side result cache is used to cache the results of the current queries, query fragments, and PL/SQL functions in memory. The cached results are used in future uses of the query, query fragment, or PL/SQL function.

The cached results stay in the result cache memory part of the SGA. A cached result is automatically invalidated whenever a database object used in its creation is successfully changed. See [Tuning the Result Cache](#) for more information about configuring the server-side result set cache.

To enable the server-side result cache on True Cache:

1. On the primary database, verify that your query is eligible to take advantage of query result caching.

For a query to be eligible for result caching, it has to satisfy certain requirements. See [Requirements for the Result Cache](#).

2. On the primary database, allow the table's query results to be stored in the result cache for True Cache.

```
ALTER TABLE table_name RESULT_CACHE (STANDBY ENABLE);
```

3. On True Cache, verify that the result cache is working for queries against the table.

```
SELECT /*+ RESULT_CACHE */ DISTINCT(column_name) FROM table_name;
```

4. For query result caching on True Cache to behave the same as on the primary database, configure the query result cache size to be identical on both.

In particular, set `RESULT_CACHE_MAX_SIZE` to the same value (and greater than 0) on both the primary database and True Cache. If the result cache size is smaller than the query result set, the database will use physical reads.

Support for server-side result set caching is available for both DBCA Thin and DBCA Oracle Call Interface (DBCA OCI) drivers.

Related Topics

- [Using the Result Cache on Physical Standby Databases](#)

8.2 KEEP Buffer Pool

You can use the `KEEP` buffer pool to keep frequently accessed tables persistent in the buffer pool.

8.2.1 Overview of Using the KEEP Buffer Pool with True Cache

You can assign different objects to the `KEEP` buffer pool on different True Caches.

At a high level, this involves the following steps:

1. Configure `DB_KEEP_CACHE_SIZE` on True Cache.
2. Assign objects on True Cache to the `KEEP` buffer pool.

As with the primary database, when an object is assigned to the `KEEP` buffer pool on True Cache, the object's blocks are loaded for a query and then kept in the `KEEP` buffer pool. When new data is inserted into the object on the primary database, that new data is automatically propagated to the `KEEP` buffer pool on True Cache through the redo apply mechanism.

To propagate direct load data to True Cache, specify the `LOGGING` clause in the corresponding DDL or DML, or alter the corresponding object property to `LOGGING`. The `LOGGING` clause lets you specify whether certain operations will be logged in the redo log file (`LOGGING`) or not (`NOLOGGING`).

Related Topics

- [Configuring the KEEP Pool](#)
- [logging_clause](#)

8.2.1.1 Supported Objects

The `KEEP` mechanism only tracks objects that have physical data segments.

To see if an object can be tracked, make sure it has a `DATA_OBJECT_ID` in the `DBA_OBJECTS` view.

Related Topics

- [DBA_OBJECTS](#)

8.2.1.2 How True Cache Works with the Primary Database Buffer Cache

By default, marking something `KEEP` on the primary database also marks it `KEEP` on True Cache.

To prevent objects that are intended to be `KEEP` objects only on the primary database from filling up the True Cache `KEEP` buffer pool, you can use the `DBMS_CACHEUTIL.TRUE_CACHE_KEEP` procedure to mark objects as `KEEP` on True Cache. `DBMS_CACHEUTIL.TRUE_CACHE_KEEP` takes precedence and overrides objects that are marked as `KEEP` on the primary database.

Also consider the following points:

- `ALTER TABLE KEEP` assignments on the primary database are persistent because `ALTER TABLE` is a DDL. The `DBMS_CACHEUTIL.TRUE_CACHE_KEEP` procedure isn't persistent when True Cache restarts.
- You can't use the `DBMS_CACHEUTIL.TRUE_CACHE_UNKEEP` procedure to unkeep a primary `ALTER TABLE KEEP` assignment. Instead, either don't configure `DB_KEEP_CACHE_SIZE` on True Cache or assign a different object with `DBMS_CACHEUTIL.TRUE_CACHE_KEEP` on True Cache.
- All scans on True Cache use the `CACHE` path instead of the direct (`NOCACHE`) path, except temporary tables that are local to True Cache.

8.2.2 Configuring DB_KEEP_CACHE_SIZE on True Cache

To configure the KEEP buffer pool on True Cache, set the DB_KEEP_CACHE_SIZE initialization parameter to a large size (such as 10 GB).

For example:

```
ALTER SYSTEM SET DB_KEEP_CACHE_SIZE=size SCOPE=BOTH;
```

Related Topics

- [DB_KEEP_CACHE_SIZE](#)
- [Setting or Changing Initialization Parameter Values](#)

8.2.3 Assigning Objects to the KEEP Buffer Pool for True Cache

After configuring the KEEP buffer pool, assign the object to the KEEP buffer pool for True Cache.

To do this, call the DBMS_CACHEUTIL.TRUE_CACHE_KEEP() procedure on True Cache.

Example: Nonpartitioned Object

```
EXECUTE DBMS_CACHEUTIL.TRUE_CACHE_KEEP('SYS', 'TABLE1');
```

Example: Partition of a Partitioned Object

```
EXECUTE DBMS_CACHEUTIL.TRUE_CACHE_KEEP('SYS', 'TABLE2', 'TABLE2_PART1');
```

8.2.3.1 TRUE_CACHE_KEEP Procedure

When you call this procedure on True Cache, it assigns the object to the KEEP buffer pool on that cache.

To use this procedure, the DB_KEEP_CACHE_SIZE initialization parameter must be configured on True Cache.

Syntax

```
DBMS_CACHEUTIL.TRUE_CACHE_KEEP(
  schema           IN VARCHAR2,
  obj              IN VARCHAR2,
  partition        IN VARCHAR2 := NULL);
```

Parameters

Table 8-1 TRUE_CACHE_KEEP Procedure Parameters

Parameter	Description
schema	The name of the schema for the object.
obj	The name of the object.

Table 8-1 (Cont.) TRUE_CACHE_KEEP Procedure Parameters

Parameter	Description
partition	<ul style="list-style-type: none"> If the object is not partitioned, then this is NULL. If the object is partitioned, use the name of the partition segment. If it's a composited partitioned object, use the name of the subpartition segment.

Related Topics

- Oracle AI Database PL/SQL Packages and Types Reference*

8.2.4 Removing an Object's KEEP Buffer Pool Assignment for True Cache

You can use `DBMS_CACHEUTIL.TRUE_CACHE_UNKEEP()` to remove objects from the `KEEP` buffer pool.

Note that the block is not removed immediately. Instead, it will be naturally aged out as new blocks for other objects are brought into the `KEEP` buffer pool. Also, the `KEEP` buffer pool assignment on True Cache is only remembered while True Cache is up.

Example: Nonpartitioned Object

```
EXECUTE DBMS_CACHEUTIL.TRUE_CACHE_UNKEEP('SYS', 'TABLE1');
```

Example: Partition of a Partitioned Object

```
EXECUTE DBMS_CACHEUTIL.TRUE_CACHE_UNKEEP('SYS', 'TABLE2', 'TABLE2_PART1');
```

8.2.4.1 TRUE_CACHE_UNKEEP Procedure

When an object on True Cache no longer needs to be in the `KEEP` buffer pool, use this procedure to remove the object's `KEEP` assignment.

Syntax

```
DBMS_CACHEUTIL.TRUE_CACHE_UNKEEP(
  schema          IN VARCHAR2,
  obj             IN VARCHAR2,
  partition       IN VARCHAR2 := NULL);
```

Parameters**Table 8-2 TRUE_CACHE_UNKEEP Procedure Parameters**

Parameter	Description
schema	The name of the schema for the object.
obj	The name of the object.

Table 8-2 (Cont.) TRUE_CACHE_UNKEEP Procedure Parameters

Parameter	Description
partition	<ul style="list-style-type: none"> If the object is not partitioned, then this is NULL. If the object is partitioned, use the name of the partition segment. If it's a composited partitioned object, use the name of the subpartition segment.

Related Topics

- Oracle AI Database PL/SQL Packages and Types Reference*

8.2.5 Viewing a List of KEEP Objects on True Cache

Use the `V$TRUE_CACHE_KEEP` view to see which objects are assigned to the `KEEP` buffer cache for True Cache.

Example 1

```
SELECT * FROM v$true_cache_keep;
```

```
TS_NUMBER  DATA_OBJECT_ID  CON_ID
-----  -
          5          72948          3
          5          72950          3
```

Example 2

```
SELECT owner as schema, object_name as keepobj, subobject_name as partition,
o.data_object_id
FROM dba_objects o, sys_objects so, v$true_cache_keep vtck
WHERE o.data_object_id = so.object_id
      AND vtck.con_id = sys_context('USERENV', 'CON_ID')
      AND so.ts_number=vtck.ts_number
      AND o.data_object_id = vtck.data_object_id;
```

```
SCHEMA  KEEPOBJ  PARTITION  DATA_OBJECT_ID
-----  -
SYS     TABLE1
SYS     TABLE2  TABLE2_PART1  72950
```

8.2.5.1 V\$TRUE_CACHE_KEEP Columns

The following table describes the columns in the `V$TRUE_CACHE_KEEP` view.

Column	Description
TS_NUMBER	The tablespace number.
DATA_OBJECT_ID	The dictionary object number of the segment that contains the object.

Column	Description
CON_ID	The ID of the container to which the data pertains. Possible values include: <ul style="list-style-type: none">1: This value is used for rows containing data that pertain to only the root.n: Where n is the applicable container ID for the rows containing data.

8.3 Database Smart Flash Cache

If the data that you want to cache doesn't fit in memory, you can expand the capacity of True Cache by adding flash devices. You do this by configuring Database Smart Flash Cache.

To enable Database Smart Flash Cache, see [Configuring Database Smart Flash Cache](#).

Note

To ensure that flash cache encryption is activated on True Cache, the master key must be set and active on the primary database instance, and the TDE wallet must be copied to True Cache. Otherwise, no buffer is encrypted.

The `TABLESPACE_ENCRYPTION` initialization parameter behaves as follows on True Cache:

- When `TABLESPACE_ENCRYPTION` is set to `AUTO_ENABLE`, all buffers are encrypted in flash cache on True Cache.
- When `TABLESPACE_ENCRYPTION` is set to `MANUAL_ENABLE`, the buffer is encrypted in flash cache on True Cache if the buffer was originally encrypted when fetching from the primary database.
- When `TABLESPACE_ENCRYPTION` is set to `DECRYPT_ONLY`, all buffers are not encrypted in flash cache on True Cache.

Related Topics

- [TABLESPACE_ENCRYPTION](#)

9

Deleting True Cache

You can delete True Cache with DBCA or manually.

9.1 Using DBCA to Delete True Cache

You can use DBCA to clean up the True Cache services and delete True Cache.

9.1.1 Cleaning Up the True Cache Services from the Primary Database

To delete True Cache, you need to clean up its corresponding services on the primary database.

Run the following command on the primary database to delete all the services that correspond to the True Cache that you're planning to delete.

```
$ORACLE_HOME/bin/dbca -configureDatabase -cleanupTrueCacheInstanceService -  
sourceDB primary_sid_or_db_unique_name -trueCacheConnectString  
true_cache_easy_connect_string -serviceName primary_service_name -  
trueCacheServiceName true_cache_service_name -silent
```

Example:

```
$ORACLE_HOME/bin/dbca -configureDatabase -cleanupTrueCacheInstanceService -  
sourceDB primdbli -trueCacheConnectString tc.example.com:1522/  
tcdb1.example.com -serviceName sales -trueCacheServiceName sales_tc -silent
```

For descriptions of the parameters, see [configureDatabase](#).

9.1.2 Deleting True Cache from the True Cache Node

Run the following command to delete True Cache from the True Cache node.

```
$ORACLE_HOME/bin/dbca -deleteDatabase -sourceDB  
true_cache_sid_or_db_unique_name -silent
```

Example:

```
$ORACLE_HOME/bin/dbca -deleteDatabase -sourceDB tcdb1 -silent
```

9.2 Deleting True Cache Manually

To delete True Cache manually, use the following commands.

```
connect / as SYSDBA;
```

```
shutdown immediate;
```

```
startup mount exclusive restrict;
```

```
drop true cache;
```

Note

This does *not* drop the primary database. It deletes the True Cache `SPFILE`; drops the True Cache control, standby log, and temporary files; and removes `LOG_ARCHIVE_DEST` entries from the primary database.

10

Deploying Oracle True Cache with Oracle Global Data Services

You can deploy Oracle True Cache with Oracle AI Database Global Data Services (GDS) to manage workload routing, dynamic load balancing, and service failover across multiple True Caches and other database replicas.

10.1 Global Data Services Overview

Oracle Global Data Services (GDS) provides workload routing based on load, locality, or lag, as well as service failover across replicas.

This helps enterprises maximize application performance, mitigate downtime during planned and unplanned outages, and manage resources of replicas with one interface.

GDS supports Oracle AI Databases, standby databases, GoldenGate replicated databases, Oracle Globally Distributed AI Databases, True Caches, and more.

You create and manage the GDS configuration and global services with the `GDSCTL` command-line interface, which is similar to the `SRVCTL` command-line interface used to manage an Oracle Real Application Clusters (Oracle RAC) database and its services.

A GDS configuration includes the following components:

- The **GDS catalog** stores configuration data for a GDS configuration. The GDS catalog resides in an Oracle AI Database. For large-scale GDS configurations, Oracle recommends that the GDS catalog be hosted outside the databases in the GDS configuration.
- A **GDS region** is a group of databases, True Caches, and clients in close network proximity (for example, east and west). For high availability, assign a buddy region for each region. Only one buddy region is allowed for each region.
- A **global service manager (GSM)** is the central software of GDS, providing service-level load balancing, failover, and centralized management of services in the GDS configuration. For high availability, include two GSMs in each region.
- A **GDS pool** is a group of databases and True Caches that offer a common set of global services (for example, human resources and sales). A region can contain multiple GDS pools, and these pools can span multiple regions. A database or True Cache can only belong to a single GDS pool. All databases and True Caches that provide the same global service must belong to the same pool.
- **Global services** are functionally similar to the local database application services that are provided by single-instance or Oracle RAC databases. The main difference between global services and local services is that global services span the instances of multiple databases, whereas local services span the instances of a single database.
- A **client connection pool**, such as the Oracle universal connection pool (UCP) JDBC connection pool that can receive load balancing recommendations is required for global runtime connection load balancing.

- An **Oracle Notification Service (ONS) server** is located with each GSM. All ONS servers in a region are interconnected in an ONS server network. The GSMs create runtime load balancing advisories and publish them to the client connection pool through the ONS server network.

Related Topics

- [Introduction to Oracle Global Data Services](#)

10.2 True Cache Integration with Global Data Services

True Cache provides the following integrations with Oracle Global Data Services (GDS).

- GDS provides the `-role TRUE_CACHE` option for global services.
- The True Cache application programming model using `JDBC SetReadOnly()` supports global services.
- GDS provides load balancing and service failover between multiple True Caches.

10.3 True Cache Implementation with Global Data Services

These examples show some of the most common use cases for implementing True Cache with Oracle Global Data Services (GDS).

10.3.1 Configuring True Cache for High Availability (Failover to Read-Write)

In this mode, the application sends all read-write workloads to the primary database and all read-only workloads to True Cache.

If True Cache is unavailable, the application sends all read-only workloads to the primary database.

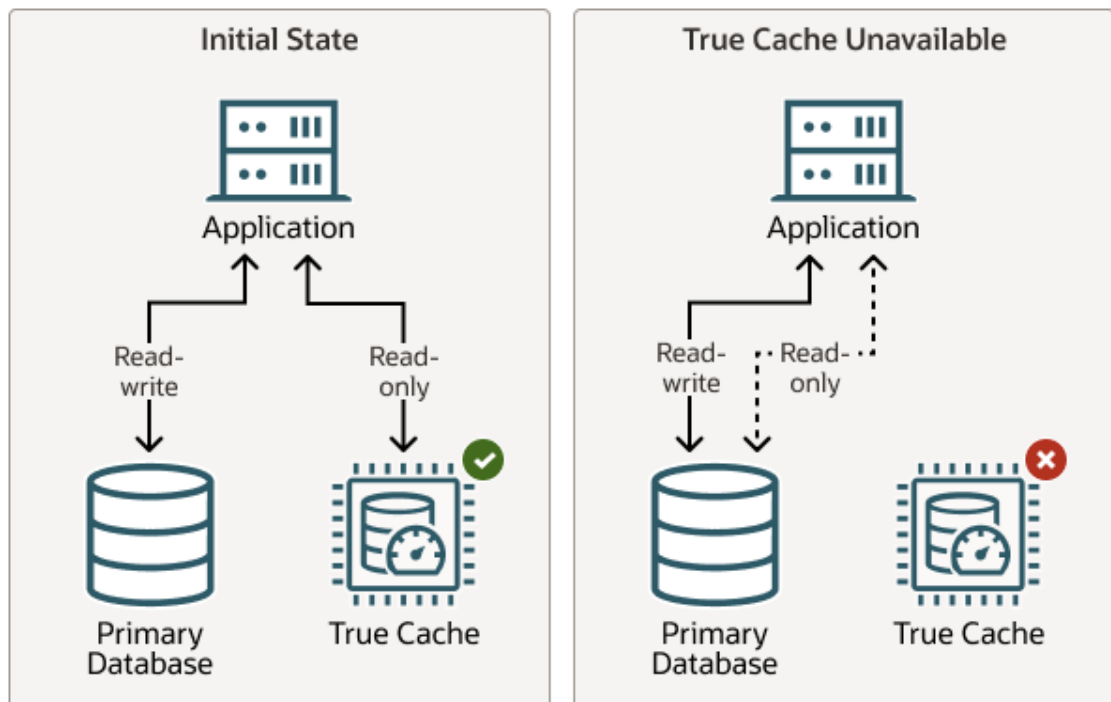

The following `GDSCCTL` commands add the services:

```
add service -service sales.example.com -gdspool sales -preferred primdbli -
pdbname sales_pdb -role primary
add service -service sales_tc.example.com -gdspool sales -preferred_all -
pdbname sales_pdb -role true_cache -failover_primary
```

Note

To use the `-failover_primary` option, install patch 37099586 on the GSM home.

10.3.2 Using True Cache for Read Offloading and Write Redirection

In this model, applications send read-write workloads to the primary database and offload some or all read-only workloads to True Cache.

The following example has two applications:

- Application 1 sends read-write workloads to the primary database and offloads infrequent read-only workloads to True Cache.
- Application 2 sends read-only workloads to True Cache and occasional read-write workloads to the primary database.

If True Cache is unavailable, both applications send all read-only workloads to the primary database.

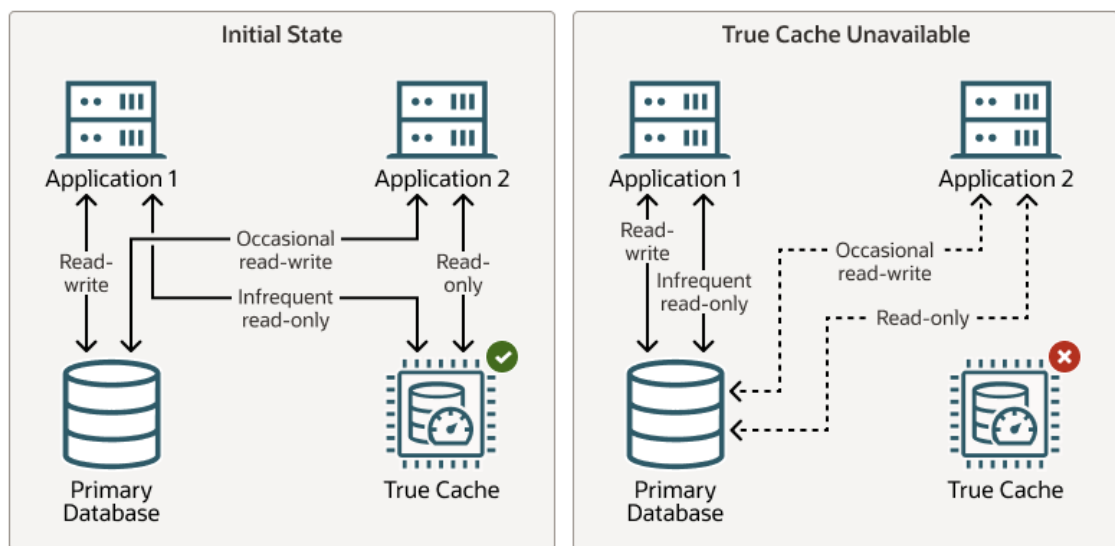

The following `GDSCCTL` commands add the services:

```
add service -service sales1.example.com -gdspool sales -preferred primdbli -
pdbname sales_pdb -role primary
add service -service sales2.example.com -gdspool sales -preferred primdbli -
pdbname sales_pdb -role primary
add service -service sales1_tc.example.com -gdspool sales -preferred_all -
```

```

pdbname sales_pdb -role true_cache -failover_primary
add service -service sales2_tc.example.com -gdspool sales -preferred_all -
pdbname sales_pdb -role true_cache -failover_primary

```

① Note

To use the `-failover_primary` option, install patch 37099586 on the GSM home.

10.3.3 Using True Cache for a Singleton Read-Only Service

In this model, applications share a service that runs on only one True Cache at a time, for example, because they need to read data from the same point in time.

The following example has two applications and two True Caches. The applications share one service to send read-write workloads to the primary database, and they share another service to send read-only workloads to the preferred True Cache. If the preferred True Cache is unavailable, the service fails over to the other available True Cache. If both True Caches are unavailable, the applications send read-only workloads to the primary database.

If a True Cache falls behind the primary database beyond the specified lag time, the service stop forwarding requests to that True Cache until it catches up.

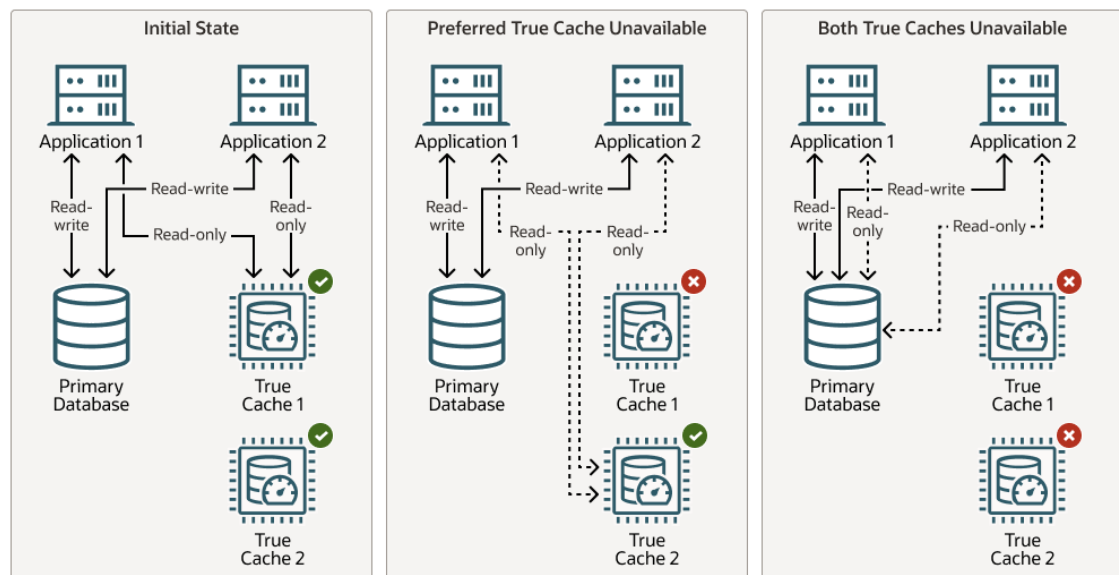

The following `GDSCCTL` commands add the services:

```

add service -service sales.example.com -gdspool sales -preferred primdbli -
pdbname sales_pdb -role primary
add service -service sales_tc.example.com -gdspool sales -preferred TC1 -
available TC2, primdbli -pdbname sales_pdb -role true_cache -failover_primary
-lag 15

```

Note

When adding True Cache services with a preferred True Cache, you currently need to include the primary database in the `-available` list. This might change in the future.

Note

To use the `-failover_primary` option, install patch 37099586 on the GSM home.

10.3.4 Configuring True Cache as a Reader Farm (Read-Only)

In this model, services for specific workloads run on dedicated True Caches and failover to True Caches that are dedicated to other services if the initial True Caches become unavailable.

The following example has three applications: music, video, and books. Each application sends read-only workloads to two dedicated True Caches.

If the dedicated True Caches for one application are unavailable, the application sends workloads to True Caches that are dedicated to another service.

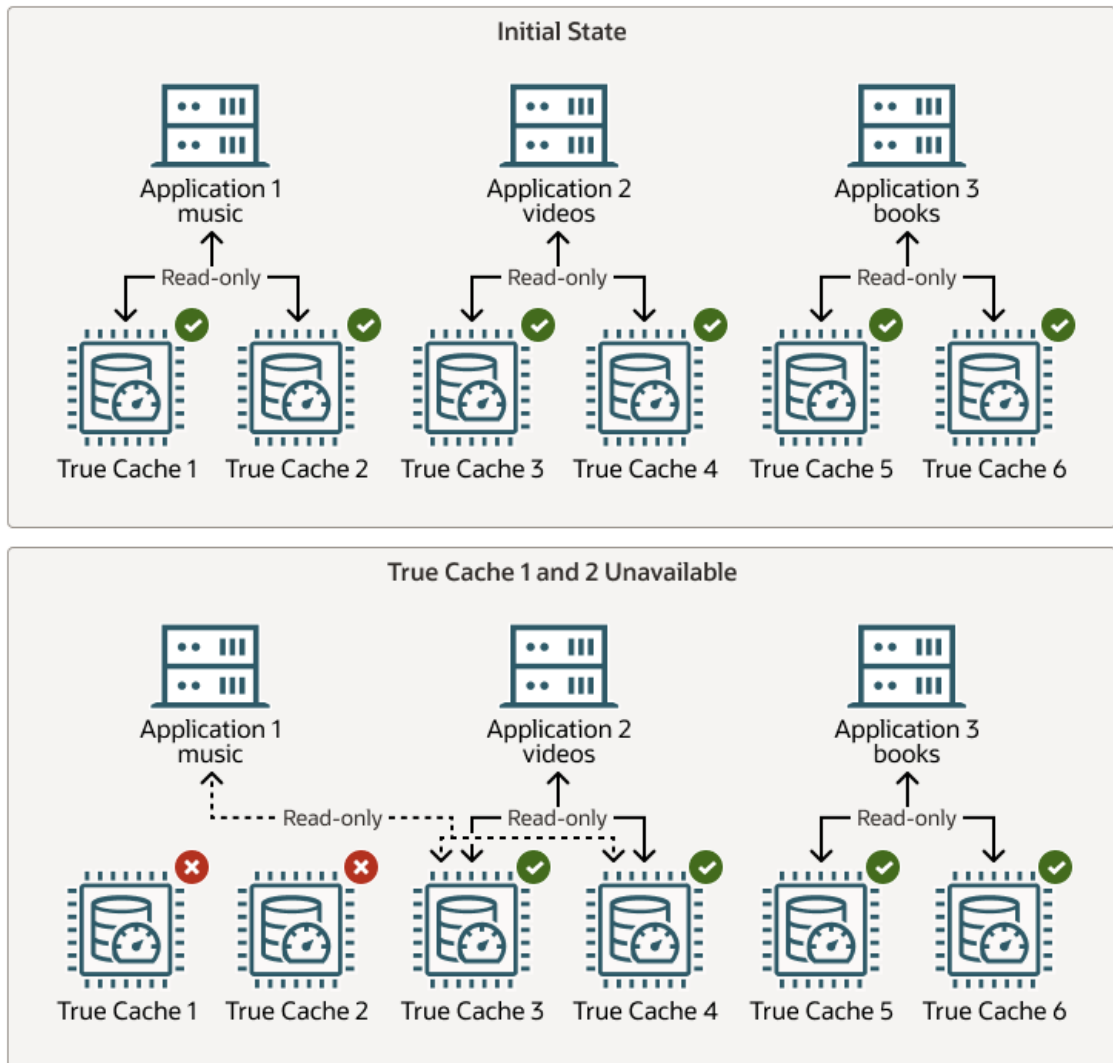

The following GDSCTL commands add the services:

```
add service -service music.example.com -gdspool sales -preferred TC1, TC2 -
available TC3, TC4, primdbli -pdbname sales_pdb -role true_cache
add service -service video.example.com -gdspool sales -preferred TC3, TC4 -
available TC5, TC6, primdbli -pdbname sales_pdb -role true_cache
add service -service books.example.com -gdspool sales -preferred TC5, TC6 -
available TC1, TC2, primdbli -pdbname sales_pdb -role true_cache
```

① Note

When adding True Cache services with a preferred True Cache, you currently need to include the primary database in the `-available` list. This might change in the future.

10.4 Configuring Global Data Services for True Cache

These are the basic steps to configure Oracle Global Data Services (GDS) for True Cache.

For additional GDS configuration options, see [Global Data Services Installation and Configuration](#).

10.4.1 Set Up the Environment

Before you install any software, review the hardware, network, operating system, and other software requirements for Linux.

- The primary database and all True Caches in the GDS pool must be able to reach (in both directions) every global service manager's (GSM's) listener and Oracle Notification Service (ONS) ports. The GSM listener ports and ONS ports must also be opened to the application tier, the primary database and all True Caches in the GDS pool, the GDS catalog, and all other GSMs.
- The TNS listener port (default: 1521) of the primary database and all True Caches in the GDS pool must be opened (in both directions) to the GSMs and the GDS catalog.
- If you run `GDSCTL` from a separate machine, you also must have a port opened (in both directions) from that machine directly to the primary database and all True Caches in the GDS pool.

For detailed information about memory, physical storage, kernel versions and packages required by Global Data Services see [Database Installation Guide for Linux](#).

Related Topics

- [Planning GDS Deployment](#)
- [Oracle Notification Service \(ONS\)](#)

10.4.2 Install the Global Service Manager Software

The global service manager (GSM) is the central component of the GDS framework, and it includes the `GDSCTL` command-line interface.

Install at least one GSM in each region. For high availability, include two GSMs in each region.

To install GSMs, see [GDS Software Installation](#).

Note

To use the `-failover_primary` option, install patch 37099586 on the GSM home.

10.4.3 Configure True Cache

Create True Caches using DBCA or manually.

Note

You don't need to configure the True Cache application services using DBCA or manually, because you will configure these as global services later using GDS.

For DBCA:

1. [Prerequisites](#)

2. [Creating True Cache with DBCA](#)

For a manual configuration:

1. [Prerequisites](#)
2. [Creating True Cache Manually](#)

10.4.4 Configure the GDS Catalog Database

Configure the database where the GDS catalog will reside.

Note

In addition to these steps, ensure that the GDS catalog is protected for high availability and disaster recovery.

1. Create the GDS administrator account and grant `GSMADMIN_ROLE` privileges.

For example:

```
CREATE USER gsm_admin IDENTIFIED BY ****
```

```
GRANT gsmadmin_role TO gsm_admin
```

2. Unlock the GDS system accounts on the catalog database.

```
sqlplus / as SYSDBA
```

```
ALTER USER gsmuser ACCOUNT UNLOCK IDENTIFIED BY ****
```

```
ALTER USER gsmcatuser ACCOUNT UNLOCK IDENTIFIED BY ****
```

3. Start `GDSCTL`.

```
gdctl
```

Related Topics

- [GDS Catalog Database and GDS Catalog Setup Catalog](#)

10.4.5 Create the GDS Catalog

Create the GDS catalog on the primary database or a database outside the GDS configuration.

For large-scale GDS configurations, Oracle recommends that the GDS catalog be hosted outside the databases in the GDS configuration.

```
create catalog -database db_name -region region_list -user user_name/password
```

For example:

```
create catalog -database gdsatdb -region DCX, DC_Y -user gsmcatuser/****
```

If you don't specify a region when setting up the catalog, then a default region named `REGIONORA` is created. You can optionally add more regions later.

10.4.6 Set Up Global Service Managers

Before you can start a global service manager (GSM), you need to register the GSM with the GDS catalog.

For high availability, include two GSMs in each region.

1. Add a GSM to the region.

```
add gsm -gsm gsm_name -pwd password -catalog catalog_db_name -region  
region_name
```

For example:

```
add gsm -gsm gsm_dc_x1 -catalog primdbli -pwd **** -region DC_X
```

Note

You can run this command only on the system that hosts the GSM. Repeat the command for each GSM on each system that runs the GSM.

2. Start the GSM.

```
start gsm -gsm gsm_name
```

For example:

```
start gsm -gsm gsm_dc_x1
```

3. Check the status of the GSM.

```
status gsm
```

10.4.7 (Optional) Set Up Regions

If you didn't already set up regions when creating the GDS catalog, add a GDS region for each data center.

For high availability, assign a buddy region for each region. Only one buddy region is allowed for each region.

Note

At least one GSM must be added and running before you can add regions.

```
add region -region region_list
```

```
modify region -region region_name -buddy region_name
```

For example:

```
add region -region DC_X, DC_Y
```

```
modify region -region DC_X -buddy DC_Y
```

10.4.8 Set Up the GDS Pool

Add a GDS pool and then add the primary database and True Caches to the pool.

```
add gdspool -gdspool db_pool_list
```

```
add database -connect db_name -region region_name -gdspool gds_pool_name
```

For example:

```
add gdspool -gdspool sales
```

```
add database -connect primdbli -pwd **** -gdspool sales -region DC_X //  
primary
```

```
add database -connect tcdb1 -pwd **** -gdspool sales -region DC_X // True  
Cache
```

Note

If you receive the following warning when you add a True Cache to a GDS pool that has existing True Caches and services running, you can ignore it: ORA-44311: service *service_name* not running.

Note

You can't add True Cache to an existing GDS pool that includes a brokerage configuration (`brokerconfig`) with primary and standby databases. Instead, delete the existing pool, create a new pool, and use `add database` to add True Cache and the primary and standby databases.

10.4.9 Set Up Global Services

Create and start the global database application services for the primary database and True Caches.

Note

If the application uses the JDBC programming model, both the primary database service and True Cache service names must be fully qualified with the domain name (for example, `sales.example.com` and `sales_tc.example.com`). This is because GDS has a default domain name and is different from the database's `domain_name` parameter. This also limits the fully qualified service name to a maximum of 64 characters.

Note

The PDB name is required to create a service for a PDB. If you don't specify the PDB name, the service is created in `CDB$ROOT`.

1. Create the global services for the primary database.

```
add service -service service_name.domain_name -gdspool gdspool_name -
preferred dbname_list -pdbname primary_pdb_name -role primary
```

For example:

```
add service -service sales.example.com -gdspool sales -preferred primdbli -
pdbname sales_pdb -role primary
```

2. Create the global services for True Cache.

```
add service -service service_name.domain_name -gdspool gdspool_name -
preferred_all -pdbname primary_pdb_name -clbgoal SHORT -rlbgoal
SERVICE_TIME -locality LOCAL_ONLY -region_failover -lag lag_value -role
true_cache -failover_primary
```

For example:

```
add service -service sales_tc.example.com -gdspool sales -preferred_all -
pdbname sales_pdb -clbgoal SHORT -rlbgoal SERVICE_TIME -locality
LOCAL_ONLY -region_failover -lag 15 -role true_cache -failover_primary
```

Note

To use the `-failover_primary` option, install patch 37099586 on the GSM home.

3. Associate the True Cache service with the primary database service.

- For True Cache and single instance primary databases, use the `DBMS_SERVICE_PRIVT` PL/SQL package.

On the primary database, connect to the PDB first. The following example uses the `sales.example.com` and `sales_tc.example.com` services.

```
ALTER SESSION SET CONTAINER=primary_pdb_name;
```

```
DECLARE
    db_params sys.dbms_service_privt.svc_parameter_array;
    cl_params sys.dbms_service_privt.svc_parameter_array;
BEGIN
    -- modify an already existing primary service SALES to set the
    TRUE_CACHE_SERVICE attribute and associate with SALES_TC
    db_params('true_cache_service') := 'sales_tc.example.com';
    DBMS_SERVICE_PRIVT.MODIFY_SERVICE('sales.example.com', cl_params,
    db_params, FALSE, 1);
END;
```

- For Oracle RAC primary databases, use the `srvctl` command line utility with the `-global_override` option to alter global services.

If you configure True Cache with DBCA, use the following command:

```
srvctl add service -db primary_db_unique_name -service
primary_db_service_name.domain_name -preferred primary_db_instance_list
-pdb primary_pdb_name -global_override
```

For example:

```
srvctl add service -db primdbli -service sales.example.com -preferred
primdbli1,primdbli2 -pdb sales_pdb -global_override
```

For manual configuration options, see [Create Database Application Services on the Primary Database](#).

Note

Also disable the True Cache service on the cluster where it was added to prevent errors when stopping and restarting the primary database services. For example:

```
srvctl start service -d primdbli -s sales_tc.example.com
```

```
srvctl stop service -d primdbli -s sales_tc.example.com
```

```
srvctl disable service -d primdbli -s sales_tc.example.com
```

This doesn't affect standby databases or True Caches because they run outside the cluster where the True Cache service is disabled. The disabled status is not stored in the primary dictionary and `DBA_SERVICES`, but only in Cluster Ready Services (CRS), and only in the cluster where the True Cache service was added. Other databases outside the cluster can start the service with `DBMS_SERVICE.START_SERVICE` and aren't affected by this setting.

4. Start the services.

```
start service -service service_name.domain_name
```

The following example starts the services on the primary database and on all True Caches:

```
start service -service sales.example.com
```

```
start service -service sales_tc.example.com
```

10.4.9.1 Global Service Best Practices for JDBC

To use global services with the JDBC `setReadOnly(TRUE)` flag, follow these best practices.

- Create the global services for the primary database and True Cache using fully qualified names (for example, `sales.example.com` and `sales_tc.example.com`). This is because GDS has a default domain name and is different from the database's `domain_name` parameter. This also limits the fully qualified service name to a maximum of 64 characters.
- Use `DBMS_SERVICE_PRIVT` instead of `DBMS_SERVICE` to associate the True Cache service with the primary database service.

10.4.9.2 GDSCTL add service Options

This table describes the GDSCTL add service options that apply to True Cache.

Option	Description
<code>-available dbname_list</code>	<p>Specify a comma-delimited list of available databases or True Caches on which the service runs if the preferred ones are not available. You can't specify a list of available instances, only databases and True Caches. You can use the <code>modify service</code> command with the <code>-server_pool</code> parameter to specify instance-level preferences.</p> <p>The list of available databases or True Caches must be mutually exclusive with the list of preferred ones.</p> <p>You cannot use this option with the <code>-preferred_all</code> option.</p> <p>Note: When adding True Cache services with a preferred True Cache, you currently need to include the primary database in the <code>-available</code> list. This might change in the future.</p>
<code>-clbgoal {SHORT LONG}</code>	<p>For True Cache services, set the connection load balancing goal to <code>SHORT</code> for runtime load balancing.</p>
<code>-failover_primary</code>	<p>If the <code>-role</code> is <code>TRUE_CACHE</code>, you can use this option to enable the service to failover to the primary database if no True Caches are available. Also include the primary database in the <code>-preferred</code> or <code>-available</code> list, or use the <code>-preferred_all</code> option.</p> <p>Note: To use the <code>-failover_primary</code> option, install patch 37099586 on the GSM home.</p>
<code>-gdspool gdspool_name</code>	<p>Specify the name of the global data services pool to which you want to add a service. If the pool name is not specified and there is only one <code>gdspool</code> with access granted to the user, then the <code>gdspool</code> with access granted is used as the default <code>gdspool</code>.</p>
<code>-lag {lag_value ANY}</code>	<p>Specify the maximum acceptable lag for the service in seconds. Enter <code>ANY</code> if there is no upper threshold. If a True Cache falls behind the primary database beyond the specified lag time, the service stop forwarding requests to that True Cache until it catches up.</p> <p>The default value for <code>lag</code>, if not specified, is <code>ANY</code>.</p>
<code>-locality {ANYWHERE LOCAL_ONLY}</code>	<p>For True Cache services, set the locality to <code>LOCAL_ONLY</code>. This indicates that GDS only routes to True Caches in the same region, regardless of load. Use this option together with <code>-region_failover</code> so that client connections and requests are routed to another region if all True Caches in a region have failed.</p>
<code>-pdbname primary_pdb_name</code>	<p>Enter the primary pluggable database (PDB) name.</p> <p>Note: The PDB name is required to create a service for a PDB. If you don't specify the PDB name, the service is created in <code>CDB\$ROOT</code>.</p>
<code>-preferred dbname_list</code>	<p>Specify a comma-delimited list of preferred databases or True Caches on which the service runs. You can't specify preferred instances, only databases and True Caches. You can use the <code>modify service</code> command to specify instance-level preferences.</p> <p>The list of preferred databases or True Caches must be mutually exclusive with the list of available ones.</p> <p>You cannot use this option with the <code>-preferred_all</code> option.</p>
<code>-preferred_all</code>	<p>For True Cache services, indicates that this service will be started on all existing and future True Caches and, if used with <code>-failover_primary</code>, the primary database.</p>

Option	Description
<code>-region_failover</code>	Indicates that the service is enabled for region failover. You can only use this option when you specify <code>LOCAL_ONLY</code> for the <code>-locality</code> option.
<code>-rlbgoal {SERVICE_TIME THROUGHPUT}</code>	For True Cache services, set the runtime load balancing goal to <code>SERVICE_TIME</code> to balance connections by response time instead of by throughput.
<code>-role {PRIMARY [PHYSICAL_STANDBY TRUE_CACHE]}</code>	Specify the database role that the database must have for this service to start on that database. For primary database services, use <code>PRIMARY</code> . For True Cache services, use <code>TRUE_CACHE</code> . This ensure that the service only runs on other True Caches, not on the primary database.
<code>-service service_name.domain_name</code>	Specify the name of the global service. Note: If the application uses the JDBC programming model, both the primary database service and True Cache service names must be fully qualified with the domain name (for example, <code>sales.example.com</code> and <code>sales_tc.example.com</code>). This is because GDS has a default domain name and is different from the database's <code>domain_name</code> parameter. This also limits the fully qualified service name to a maximum of 64 characters. A global service name must be unique within a GDS pool and when qualified by domain, must also be unique within a GDS configuration. A global service cannot be created at a database if a local or global service with the same name already exists at that database. A global service name can contain alphanumeric characters, underscore (<code>_</code>), and period (<code>.</code>). The first character must be alphanumeric. The maximum length of a global service name is 64 characters. The maximum length of a domain qualified global service name is 250 characters. An Oracle Net connect descriptor used to connect to a global service must contain a domain qualified service name. For True Cache service names, see Best Practices for Database Application Services .

Note

This table lists the add service options that are specific to True Cache. For the full syntax and parameters, see [add service](#) in the *Oracle AI Database Global Data Services Concepts and Administration Guide*.

10.4.10 Set Up the Client TNS Entry

Update the `tnsnames.ora` files for the primary database and True Caches based on region.

Example 10-1 Primary Database

In this example, the `ADDRESS_LIST` points to the GSM in the region where the primary database is located.

```
sales =
(DESCRIPTION =(CONNECT_TIMEOUT=90)(RETRY_COUNT=30)(RETRY_DELAY=3)
(TRANSPORT_CONNECT_TIMEOUT=3))
```

```
(FAILOVER=ON)
  (ADDRESS_LIST = //Lists DC_X's GSM listeners because primary is in DC_X
  (LOAD_BALANCE=ON)
  (ADDRESS = (PROTOCOL = TCP)(HOST = gsm_dc_x1)(PORT = 1572)))
(CONNECT_DATA =
  (SERVICE_NAME = sales.example.com))
```

Example 10-2 True Cache

In this example, the first ADDRESS_LIST points to the GSM in the region where the True Cache is located. The second ADDRESS_LIST points to the GSM in the associated buddy region.

```
sales_tc =
(DESCRIPTION = (CONNECT_TIMEOUT=90)(RETRY_COUNT=30)(RETRY_DELAY=3)
(TRANSPORT_CONNECT_TIMEOUT=3)
(FAILOVER=ON)
  (ADDRESS_LIST = //DC_X's GSM listeners
  (LOAD_BALANCE=ON)
  (ADDRESS = (PROTOCOL = TCP)(HOST = gsm_dc_x1)(PORT = 1572)))
  (ADDRESS_LIST = //buddy DC_Y's GSM listeners
  (LOAD_BALANCE=ON)
  (ADDRESS = (PROTOCOL = TCP)(HOST = gsm_dc_y1)(PORT = 1572)))
(CONNECT_DATA =
  (SERVICE_NAME = sales_tc.example.com) (REGION=DC_X)) // this client is
in DC_X
```

10.5 True Cache Restrictions with Oracle Global Data Services

Deploying True Cache with Oracle GDS has the following restrictions.

- When adding True Cache services in GDSCtl with the `-failover_primary` option, install patch 37099586 on the GSM home.
- When adding True Cache services with a preferred True Cache, you currently need to include the primary database in the `-available` list. This might change in the future.
- If the application uses the JDBC programming model, both the primary database service and True Cache service names must be fully qualified with the domain name (for example, `sales.example.com` and `sales_tc.example.com`). This is because GDS has a default domain name and is different from the database's `domain_name` parameter. This also limits the fully qualified service name to a maximum of 64 characters.

A

True Cache Error Messages

View error messages that you might encounter when using True Cache.

Select an error message to read the full description in the [Error Help Portal](#).

- [DBT-19951 True Cache feature is not supported on this database.](#)
- [DBT-19953 True Cache is not in redo apply mode.](#)
- [DBT-19961 Specified database 'string' is associated with following True Caches: 'string'. After deletion of 'string', the True Caches will be unusable.](#)
- [DBT-19963 Total size of SGA 'string' and PGA 'string' exceeded maximum memory allowed for Oracle Free True Cache.](#)
- [DBT-19964 The SID name for the Oracle Free True Cache is invalid.](#)
- [DBT-19965 Failed to create the Windows service for True Cache 'string'.](#)
- [DBT-19967 Failed to copy the password file to provided location 'string'.](#)
- [DBT-19968 Oracle True Cache can not be created in the current Oracle Home.](#)
- [DIA-24532 Heterogeneous session pool creation with true cache is failing.](#)
- [DIA-24533 True Cache session unavailable.](#)
- [DIA-24534 Could not create pool in True Cache mode.](#)
- [OCI-03180 Sequence values cannot be allocated for Oracle Active Data Guard standby or at True Cache.](#)
- [OCI-18719 The database does not support True Cache. Minimum supported version is 26ai](#)
- [OCI-18720 True Cache service is not configured on the database](#)
- [OCI-24532 Heterogeneous session pool creation with true cache is failing.](#)
- [OCI-24533 True Cache session unavailable.](#)
- [OCI-24534 Could not create pool in True Cache mode.](#)
- [OCI-61850 Oracle version mismatch between primary database and True Cache.](#)
- [OCI-61851 True Cache instance does not allow string operation.](#)
- [OCI-61852 CREATE TRUE CACHE failed.](#)
- [OCI-61853 Cannot start True Cache.](#)
- [OCI-61854 Cannot start True Cache with non True Cache control file.](#)
- [OCI-61856 True Cache requires a valid parameter value for string.](#)
- [OCI-61857 Communication with the primary database failed.](#)
- [OCI-61859 There was an error when executing a remote procedure call \(op: string-string-string\) at primary server string.](#)
- [OCI-61860 True Cache instance is being shutdown because it has been disconnected from the primary for too long.](#)

- [OCI-61861 Unable to receive redo since standby redo log is not available](#)
- [OCI-61862 String is not configured as a multitenant database](#)
- [OCI-61863 True Cache could not be started because there was a configuration parameter mismatch with the primary. Restart the database.](#)
- [OCI-61864 True Cache failed to read metadata from the primary.](#)
- [OCI-61865 The TNS alias string could not be translated.](#)
- [OCI-61866 Some static parameters \(string\) differed from the value in the primary database. These parameters have been fixed and the database will be shut down.](#)
- [OCI-61867 Oracle True Cache failed to restart. Shutting down.](#)
- [OCI-61868 True Cache entry corresponding to the hash ID string not found in a LOG_ARCHIVE_DEST_n parameter.](#)
- [OCI-61869 Unable to connect to True Cache.](#)
- [OCI-61870 True Cache requires ARCHIVELOG mode to be enabled at the primary database.](#)
- [OCI-61871 True Cache instance is being shut down.](#)
- [OCI-61872 The string command in pluggable database string failed because some process is keeping a lock on it for too long. True cache will be restarted.](#)
- [OCI-61873 True Cache could not be started because the system parameter 'string' is different in the PRIMARY database. Remove the parameter from the True Cache initialization file.](#)
- [OCI-61875 There was a failure adding the system parameter LOG_ARCHIVE_DEST_n at the primary database. True Cache database cannot be opened without it.](#)
- [OCI-61876 Failed to open True Cache because the primary database is configured for shared server.](#)
- [OCI-61877 True Cache recovery lags too far behind, exceeding string seconds.](#)
- [OCI-61878 PDB \(con_id:string\) is not open on the primary database.](#)
- [OCI-61879 db_keep_cache_size is not configured on True Cache](#)
- [OCI-61880 This operation \(string\) is only allowed on True Cache instance.](#)
- [OCI-61881 Failed to open True Cache because there has been an error reading metadata \(string\) from the primary database string.](#)
- [OCI-61882 Cannot start Free Edition True Cache because the maximum number of configured Free Edition True Caches \(string\) for the database has been reached already.](#)
- [ORA-03180 Sequence values cannot be allocated for Oracle Active Data Guard standby or at True Cache.](#)
- [ORA-18719 The database does not support True Cache. Minimum supported version is 26ai](#)
- [ORA-18720 True Cache service is not configured on the database](#)
- [ORA-24532 Heterogeneous session pool creation with true cache is failing.](#)
- [ORA-24533 True Cache session unavailable.](#)
- [ORA-24534 Could not create pool in True Cache mode.](#)
- [ORA-61850 Oracle version mismatch between primary database and True Cache.](#)
- [ORA-61851 True Cache instance does not allow string operation.](#)

- [ORA-61852 CREATE TRUE CACHE failed.](#)
- [ORA-61853 Cannot start True Cache.](#)
- [ORA-61854 Cannot start True Cache with non True Cache control file.](#)
- [ORA-61855 Invalid TRUE_CACHE_CONFIG attribute.](#)
- [ORA-61856 True Cache requires a valid parameter value for string.](#)
- [ORA-61857 Communication with the primary failed.](#)
- [ORA-61858 Unable to translate FAL_SERVER initialization parameter string.](#)
- [ORA-61859 There was an error when executing a remote procedure call \(op: string-string\) at primary server string.](#)
- [ORA-61860 True Cache instance is being shutdown because it has been disconnected from the primary for too long.](#)
- [ORA-61861 Unable to receive redo since standby redo log is not available.](#)
- [ORA-61862 String is not configured as a multitenant database.](#)
- [ORA-61863 True Cache could not be started because there was a configuration parameter mismatch with the primary. Restart the database.](#)
- [ORA-61864 True Cache failed to read metadata from the primary.](#)
- [ORA-61865 The TNS alias string could not be translated.](#)
- [ORA-61866 Some static parameters \(string\) differed from the value in the primary database. These parameters have been fixed and the database will be shut down.](#)
- [ORA-61867 Oracle True Cache failed to restart. Shutting down.](#)
- [ORA-61868 True Cache entry corresponding to the hash ID string not found in a LOG_ARCHIVE_DEST_n parameter.](#)
- [ORA-61869 Unable to connect to True Cache.](#)
- [ORA-61870 True Cache requires ARCHIVELOG mode to be enabled at the primary database.](#)
- [ORA-61871 True Cache instance is being shut down.](#)
- [ORA-61872 The string command in pluggable database string failed because some process is keeping a lock on it for too long. True cache will be restarted.](#)
- [ORA-61873 True Cache could not be started because the system parameter 'string' is different in the PRIMARY database. Remove the parameter from the True Cache initialization file.](#)
- [ORA-61874 Cannot fetch data block from the primary database \(file # string, block # string\).](#)
- [ORA-61875 There was a failure adding the system parameter LOG_ARCHIVE_DEST_n at the primary database. True Cache database cannot be opened without it.](#)
- [ORA-61876 Failed to open True Cache because the primary database is configured for shared server.](#)
- [ORA-61877 True Cache recovery lags too far behind, exceeding string seconds.](#)
- [ORA-61878 PDB \(con_id:string\) is not open on the primary database.](#)
- [ORA-61879 db_keep_cache_size is not configured on True Cache.](#)
- [ORA-61880 This operation \(string\) is only allowed on True Cache instance.](#)

- [ORA-61881 Failed to open True Cache because there has been an error reading metadata \(string\) from the primary database string.](#)
- [ORA-61882 Cannot start Free Edition True Cache because the maximum number of configured Free Edition True Caches \(string\) for the database has been reached already.](#)
- [PRKZ-05094 Mismatching number of services specified in {0} and {1}](#)
- [RMAN-06622 Recovery Manager \(RMAN\) cannot connect to a true cache database.](#)

B

True Cache Database Statistics Descriptions

The following table describes the True Cache-related statistics stored in the `V$SESSTAT` and `V$SYSSTAT` views.

For details on classes and `TIMED_STATISTICS`, see [Statistics Descriptions](#).

Table B-1 Database Statistics Descriptions

Name	Class	Description	TIMED_STATISTICS
TrueCache: block requests to preferred primary	264	Number of block fetch requests sent to the preferred primary Oracle RAC instance with object or undo affinity.	
TrueCache: block requests to primary	264	Total number of block fetch requests sent to the primary database.	
True Cache: message roundtrip time data send	256	Cumulative, elapsed, round-trip messaging time in microseconds of this primary instance sending data blocks to True Cache.	
True Cache: message roundtrip time request send	256	Cumulative, elapsed, round-trip messaging time in microseconds of this True Cache sending data block fetching requests to the primary database.	
True Cache: message count data send	256	Total number of messages this primary instance sends to True Cache for returning data blocks.	
True Cache: message count request send	256	Total number of messages this True Cache sends to the primary database for requesting data blocks.	
True Cache potentially current buffer made current	264	Count of data blocks arriving at True Cache as potentially current buffers due to timing conditions, and later confirmed to be real current buffers, so redo will continue to apply.	
True Cache potentially current buffer made CR	264	Count of data blocks arriving at True Cache as potentially current buffers due to timing conditions, and later deemed to be good only as consistent read buffers, so they will be aged out.	

C

True Cache Wait Events

The following True Cache-related wait events are used for block fetching.

Table C-1 Wait Events

Wait Event	Class
True Cache: single block fetch	User I/O
True Cache: multiblock fetch	User I/O
True Cache: list of blocks fetch	User I/O

Related Topics

- [Oracle Wait Events](#)

D

Licensing for True Cache

True Cache licensing is based on the edition of Oracle AI Database that you're using for both the primary database and True Cache.

See [Permitted Features, Options, and Management Packs by Oracle AI Database Offering](#) in the *Oracle AI Database Licensing Information User Manual*.

E

Troubleshooting True Cache

Follow these recommendations if you run into issues when configuring or using True Cache.

E.1 Rerunning DBCA

If you run into issues when configuring True Cache with DBCA, you need to clean up the True Cache node and then rerun DBCA.

E.1.1 Rerunning DBCA After Creating True Cache

If you need to rerun DBCA after creating True Cache, clean up the True Cache node first.

If you don't do the cleanup, DBCA might say that the instance already exists.

1. Shut down True Cache if it was started during the creation. See [Shutting Down True Cache](#).
2. Remove any newly created files in the `$ORACLE_HOME/dbs` directory for True Cache. File names contain the True Cache name.
3. If you used a Transparent Data Encryption (TDE) auto-login wallet, delete the wallet and auto-login file in the `$ORACLE_BASE/admin/true_cache_name/wallet_root/tde/` directory.
4. Create True Cache again. See [Creating True Cache with DBCA](#).

E.1.2 Rerunning DBCA After Configuring True Cache Database Application Services

If you need to rerun DBCA after configuring True Cache database application services, you might need to delete the True Cache service from the primary pluggable database (PDB) using the `DBMS_Service` package.

Example error message:

```
[DBT-19958] Database service 'trueCacheServiceName'
```

1. For services that are specific to a PDB, connect to the specific PDB, or set the correct PDB container in your session.
2. Connect to True Cache and stop the True Cache service on True Cache if it's running.

```
EXEC DBMS_SERVICE.STOP_SERVICE('trueCacheServiceName');
```
3. Delete the service on the primary database using `DBMS_SERVICE.DELETE_SERVICE`.

```
EXEC DBMS_SERVICE.DELETE_SERVICE('trueCacheServiceName');
```
4. Configuration the True Cache application service again. See [Configuring True Cache Database Application Services with DBCA](#).

E.2 Preventing SRVCTL from Restarting True Cache Services for Oracle RAC Primary Databases

To prevent errors when stopping and restarting primary database services for Oracle RAC database, disable the True Cache service on the cluster where it was added.

The following errors might occur:

```
PRCD-1133: failed to start services for database
PRCR-1095: Failed to start resources using filter
CRS-2501: Resource 'ora.primary_db.true_cache_service.svc' is disabled
```

To prevent these errors, disable the True Cache service on the cluster where it was added. For example:

```
srvctl disable service -d primdbli -s sales_tc
```

This doesn't affect standby databases or True Caches because they run outside the cluster where the True Cache service is disabled. The disabled status is not stored in `DBMS_SERVICE/service$`, but only in Cluster Ready Services (CRS), and only in the cluster where the True Cache service was added. Other databases outside the cluster can start the service with `DBMS_SERVICE.START_SERVICE` and aren't affected by this setting.

Related Topics

- [Configuring True Cache Database Application Services with DBCA](#)
To use True Cache with the JDBC Thin driver, for each primary database application service that you want to cache, create a corresponding True Cache database application service.
- [Configuring True Cache Database Application Services Manually](#)
To use True Cache with the JDBC Thin driver, for each primary database application service that you want to cache, create a corresponding True Cache database application service.
- [Deploying True Cache for an Oracle RAC Primary Database](#)
This section summarizes the configuration requirements for deploying True Cache for a primary database in an Oracle Real Application Clusters (Oracle RAC) environment. These requirements are also included in context within the detailed configuration steps.