

Oracle® Database Appliance X10

Owner's Guide



F92324-01
March 2024



Oracle Database Appliance X10 Owner's Guide,

F92324-01

Copyright © 2024, Oracle and/or its affiliates.

Primary Author: Ralph Woodley

This software and related documentation are provided under a license agreement containing restrictions on use and disclosure and are protected by intellectual property laws. Except as expressly permitted in your license agreement or allowed by law, you may not use, copy, reproduce, translate, broadcast, modify, license, transmit, distribute, exhibit, perform, publish, or display any part, in any form, or by any means. Reverse engineering, disassembly, or decompilation of this software, unless required by law for interoperability, is prohibited.

The information contained herein is subject to change without notice and is not warranted to be error-free. If you find any errors, please report them to us in writing.

If this is software, software documentation, data (as defined in the Federal Acquisition Regulation), or related documentation that is delivered to the U.S. Government or anyone licensing it on behalf of the U.S. Government, then the following notice is applicable:

U.S. GOVERNMENT END USERS: Oracle programs (including any operating system, integrated software, any programs embedded, installed, or activated on delivered hardware, and modifications of such programs) and Oracle computer documentation or other Oracle data delivered to or accessed by U.S. Government end users are "commercial computer software," "commercial computer software documentation," or "limited rights data" pursuant to the applicable Federal Acquisition Regulation and agency-specific supplemental regulations. As such, the use, reproduction, duplication, release, display, disclosure, modification, preparation of derivative works, and/or adaptation of i) Oracle programs (including any operating system, integrated software, any programs embedded, installed, or activated on delivered hardware, and modifications of such programs), ii) Oracle computer documentation and/or iii) other Oracle data, is subject to the rights and limitations specified in the license contained in the applicable contract. The terms governing the U.S. Government's use of Oracle cloud services are defined by the applicable contract for such services. No other rights are granted to the U.S. Government.

This software or hardware is developed for general use in a variety of information management applications. It is not developed or intended for use in any inherently dangerous applications, including applications that may create a risk of personal injury. If you use this software or hardware in dangerous applications, then you shall be responsible to take all appropriate fail-safe, backup, redundancy, and other measures to ensure its safe use. Oracle Corporation and its affiliates disclaim any liability for any damages caused by use of this software or hardware in dangerous applications.

Oracle®, Java, MySQL, and NetSuite are registered trademarks of Oracle and/or its affiliates. Other names may be trademarks of their respective owners.

Intel and Intel Inside are trademarks or registered trademarks of Intel Corporation. All SPARC trademarks are used under license and are trademarks or registered trademarks of SPARC International, Inc. AMD, Epyc, and the AMD logo are trademarks or registered trademarks of Advanced Micro Devices. UNIX is a registered trademark of The Open Group.

This software or hardware and documentation may provide access to or information about content, products, and services from third parties. Oracle Corporation and its affiliates are not responsible for and expressly disclaim all warranties of any kind with respect to third-party content, products, and services unless otherwise set forth in an applicable agreement between you and Oracle. Oracle Corporation and its affiliates will not be responsible for any loss, costs, or damages incurred due to your access to or use of third-party content, products, or services, except as set forth in an applicable agreement between you and Oracle.

For information about Oracle's commitment to accessibility, visit the Oracle Accessibility Program website at <http://www.oracle.com/pls/topic/lookup?ctx=acc&id=docacc>.

Contents

Preface

Audience	v
Documentation Accessibility	v
Related Documents	v
Conventions	vi

1 Oracle Database Appliance Setup Tasks

Task Checklist	1-1
----------------	-----

2 Overview of Oracle Database Appliance

Oracle Database Appliance X10 Series Components and Capabilities	2-1
Oracle Database Appliance X10-S/X10-L Front and Back Panels	2-4
Oracle Database Appliance X10-S/X10-L Front Panel	2-5
Oracle Database Appliance X10-S/X10-L Back Panel	2-6
Oracle Database Appliance X10-HA Front and Back Panels	2-8
Oracle Database Appliance X10-HA Front Panel	2-9
Server Node Front Panel Features	2-10
Storage Shelf Front Panel Features	2-11
Oracle Database Appliance X10-HA Back Panel	2-12
Server Node Back Panel Features	2-14
Storage Shelf Back Panel Features	2-15
Oracle Database Appliance Specifications	2-17
Physical Specifications for Oracle Database Appliance X10 Series	2-17
Electrical Specifications for Oracle Database Appliance X10 Series	2-18
Environmental Specifications for Oracle Database Appliance X10 Series	2-18
Technical Support	2-19

3 Site Preparation

Prepare Your Site	3-1
-------------------	-----

4 Installing Oracle Database Appliance Into a Rack

Task Overview	4-1
Optional Component Installation	4-2
Safety Precautions When Rackmounting	4-4
ESD Precautions	4-5
Rack Compatibility Requirements	4-5
Installing the System Into a Rack	4-6
Installing Oracle Database Appliance X10-S/X10-L Into a Rack	4-7
Contents of the Shipping Container	4-7
Tools and Equipment Needed	4-7
Stabilize the Rack for Installation	4-7
Rackmount Kit Contents	4-8
Install Mounting Brackets on the Server	4-8
Mark the Rackmount Location	4-9
Attach the AC Power Cables and Server Slide-Rails to the Rack	4-11
Install the Server Into the Slide-Rail Assemblies	4-13
Install the Cable Management Arm (Optional)	4-15
Installing Oracle Database Appliance X10-HA Into a Rack	4-23
Contents of the Shipping Container	4-24
Installation Sequence	4-25
Verify Component Compatibility	4-25
Tools and Equipment Needed	4-26
Stabilize the Rack for Installation	4-26
Apply Labels to Server Nodes	4-26
Install the Storage Shelf Into a Rack	4-27
Add a Storage Expansion Shelf to an Existing System	4-33
Rackmount Kit Contents	4-34
Install Mounting Brackets on the Server	4-34
Mark the Rackmount Location	4-35
Attach the AC Power Cables and Server Slide-Rails to the Rack	4-37
Install the Server Into the Slide-Rail Assemblies	4-39
Install the Cable Management Arm (Optional)	4-41

Index

Preface

This guide provides a system overview and instructions for racking the Oracle Database Appliance.

- [Audience](#)
- [Documentation Accessibility](#)
- [Related Documents](#)
- [Conventions](#)

Audience

This document is intended for technicians, system administrators, and authorized service providers responsible for installing the Oracle Database Appliance.

Documentation Accessibility

For information about Oracle's commitment to accessibility, visit the Oracle Accessibility Program website at <https://www.oracle.com/pls/topic/lookup?ctx=acc&id=docacc>.

Access to Oracle Support

Oracle customers that have purchased support have access to electronic support through My Oracle Support. For information, visit <https://www.oracle.com/pls/topic/lookup?ctx=acc&id=info> or visit <https://www.oracle.com/pls/topic/lookup?ctx=acc&id=trs> if you are hearing impaired.

Related Documents

For more information about Oracle Database Appliance, go to <https://www.oracle.com/goto/oda/docs> and click the appropriate release. The following documents are published in the Oracle Database Appliance online documentation library:

- *Oracle Database Appliance Release Notes*
- *Oracle Database Appliance Licensing Information User Manual*
- *Oracle Database Appliance Security Guide*
- *Oracle Database Appliance Accessibility Guide*
- *Oracle Database Appliance Deployment and User's Guide (model-specific)*
- *Oracle Database Appliance Owner's Guide*
- *Oracle Database Appliance Service Manual*

Conventions

The following text conventions are used in this document:

Convention	Meaning
boldface	Boldface type indicates graphical user interface elements associated with an action or terms defined in the text.
<i>italic</i>	Italic type indicates book titles, emphasis, or placeholder variables for which you supply particular values.
monospace	Monospace type indicates commands within a paragraph, URLs, code in examples, text that appears on the screen, or text that you enter.
# prompt	The pound (#) prompt indicates a command that is run as the root user.

1

Oracle Database Appliance Setup Tasks

Complete these tasks to setup Oracle Database Appliance.

- [Task Checklist](#)
List of steps with links to information describing the setup of Oracle Database Appliance.

Task Checklist

List of steps with links to information describing the setup of Oracle Database Appliance.

Step	Task	Refer to
1	Access the online product documentation for your release of Oracle Database Appliance.	https://www.oracle.com/goto/oda/docs
2	Review safety information before performing the installation.	<i>Oracle Database Appliance Series Safety and Compliance Guide</i> : Online at the product documentation site <i>Important Safety Information for Oracle's Hardware Systems</i> : Printed document included in the Accessory Kit
3	Review system features and components.	Overview of Oracle Database Appliance
4	Complete the site preparation procedures.	Site Preparation
5	Rackmount the system.	Installing Oracle Database Appliance Into a Rack
6	Connect cables.	<i>Oracle Database Appliance Deployment and User's Guide</i> (model-specific): Online at the product documentation site
7	Connect to Oracle Integrated Lights Out Manager (ILOM).	<i>Oracle Database Appliance Deployment and User's Guide</i> (model-specific): Online at the product documentation site
8	Deploy Oracle Database Appliance software.	<i>Oracle Database Appliance Deployment and User's Guide</i> (model-specific): Online at the product documentation site

2

Overview of Oracle Database Appliance

Learn about Oracle Database Appliance model supported components, capabilities and features.

- [Oracle Database Appliance X10 Series Components and Capabilities](#)
See a listing of the various supported capabilities for the Oracle Database Appliance X10 series.
- [Oracle Database Appliance X10-S/X10-L Front and Back Panels](#)
See views and descriptions of front and back panel features for Oracle Database Appliance X10-S/X10-L.
- [Oracle Database Appliance X10-HA Front and Back Panels](#)
See views and descriptions of front and back panel features for Oracle Database Appliance X10-HA.
- [Oracle Database Appliance Specifications](#)
This section describes the physical, electrical and environmental specifications for the various Oracle Database Appliance models.
- [Technical Support](#)
How to obtain technical support for your appliance.

Oracle Database Appliance X10 Series Components and Capabilities

See a listing of the various supported capabilities for the Oracle Database Appliance X10 series.

The following table lists supported components and capabilities for the Oracle Database Appliance X10 series systems.

Component	Oracle Database Appliance X10-S	Oracle Database Appliance X10-L	Oracle Database Appliance X10-HA
Server node	Single 2RU server.	Single 2RU server.	Two 2RU server nodes that share production under normal conditions, but can operate independently if the other server node goes down. The lower server is Node 0. The upper server is node 1.
CPUs	One 32-core 2.7 GHz AMD EPYC™ 9334 processor.	Two 32-core 2.7 GHz AMD EPYC™ 9334 processors.	Two 32-core 2.7 GHz AMD EPYC™ 9334 processors per server node.

Component	Oracle Database Appliance X10-S	Oracle Database Appliance X10-L	Oracle Database Appliance X10-HA
Memory	<p>256 GB – four 64 GB low-voltage DDR5 registered DIMMs rated at 4800 MT/sec.</p> <p>Optional memory expansion to 786 MB. See Optional Component Installation.</p>	<p>512 GB – eight 64 GB low-voltage DDR5 registered RDIMMs rated at 4800 MT/sec.</p> <p>Optional memory expansion to 1.5 TB. See Optional Component Installation.</p>	<p>512 GB – eight 64 GB low-voltage DDR5 registered DIMMs rated at 4800 MT/sec per server node.</p> <p>Optional memory expansion to 1.5 TB per node. Both server nodes must have the same amount of memory. See Optional Component Installation.</p>
Storage devices	<p>The server includes:</p> <ul style="list-style-type: none"> Two internal 480 GB M.2 NVMe SSDs reserved for operating system storage and system booting Two 2.5-inch 6.8 TB NVMe SSDs in front slots 0 and 1 <p>No additional storage options are supported.</p>	<p>The server includes:</p> <ul style="list-style-type: none"> Two internal 480 GB M.2 NVMe SSDs reserved for operating system storage and system booting Two 2.5-inch 6.8 TB NVMe SSDs in front slots 0 and 1 <p>Two optional NVMe SSDs can be added. In addition, up to four Oracle Flash Accelerator 680 PCIe Cards. See Optional Component Installation.</p>	<p>Each server node includes:</p> <ul style="list-style-type: none"> Two internal 480 GB M.2 NVMe SSDs reserved for operating system storage and system booting <p>The 4RU storage shelf includes one of the following available configurations:</p> <ul style="list-style-type: none"> Partially populated storage shelf with either six, twelve, or eighteen 2.5-inch 7.68 TB SAS SSDs (in 3.5-inch mounting brackets) Twenty-four 2.5-inch 7.68 TB SAS SSDs (in 3.5-inch mounting brackets) in slots 0-23 Six 2.5-inch 7.68 TB SAS SSDs (in 3.5-inch mounting brackets) in slots 0-5 and eighteen 3.5-inch 22 TB SAS HDDs in slots 6-23 <p>For a partially populated storage shelf, optional 7.68 TB SAS SSDs, or 22 TB SAS HDDs can be added. See Optional Component Installation.</p>
USB 3.0 ports	One external port at the back of the server.	One external port at the back of the server.	One external port at the back of each server node.

Component	Oracle Database Appliance X10-S	Oracle Database Appliance X10-L	Oracle Database Appliance X10-HA
PCI Express (PCIe) I/O slots	<p>Nine external low-profile PCIe Gen-5 slots. However, in this single processor configuration only slots 5-9 are functional. In the base configuration:</p> <p>PCIe slot 5 contains one of the following:</p> <ul style="list-style-type: none"> Dual Port (SFP28) 25 Gb Ethernet Adapter Quad Port (RJ-45) 10Gbase-T Adapter <p>Additional option card configurations can be ordered. See Optional Component Installation.</p>	<p>Nine external low-profile PCIe Gen-5 slots. In the base configuration:</p> <p>PCIe slot 5 contains one of the following:</p> <ul style="list-style-type: none"> Dual Port (SFP28) 25 Gb Ethernet Adapter Quad Port (RJ-45) 10Gbase-T Adapter <p>PCIe slot 6 contains an Oracle Retimer Card.</p> <p>The server also supports up to four optional Oracle Flash Accelerator 680 PCIe Cards in PCIe slots 1, 2, 3 and 9.</p> <p>Additional option card configurations can be ordered. See Optional Component Installation.</p>	<p>Nine external low-profile PCIe Gen-5 slots for each server node. In the base configuration:</p> <p>PCIe slot 1 contains a Dual Port (SFP28) 25 Gb Ethernet Adapter (node interconnect)</p> <p>PCIe slot 5 contains one of the following:</p> <ul style="list-style-type: none"> Dual Port (SFP28) 25 Gb Ethernet Adapter Quad Port (RJ-45) 10Gbase-T Adapter <p>PCIe slots 2 and 9 contain a Dual-port External 12Gb/s SAS3 host bus adapter</p> <p>Additional option card configurations can be ordered. See Optional Component Installation.</p>
Cluster device	N/A	N/A	One integrated cluster device with node-to-node interconnection is provided on each server node through two 25GbE ports with SFP28 connections.
SAS ports	N/A	N/A	<p>Four external SAS3 ports on each server node.</p> <p>Eight SAS3 ports on the storage shelf (four used).</p> <p>Eight SAS3 ports on the storage expansion shelf (four used).</p>
Onboard Ethernet ports	One 10/100/1000Base-T network interface port with RJ-45 connector on each server rear panel.	One 10/100/1000Base-T network interface port with RJ-45 connector on each server rear panel.	One 10/100/1000Base-T network interface port with RJ-45 connector on each server node rear panel.
Network management (NET MGT) port	One 10/100/1000Base-T network interface port with RJ-45 connector dedicated to the service processor (SP) on each server node rear panel.	One 10/100/1000Base-T network interface port with RJ-45 connector dedicated to the service processor (SP) on each server node rear panel.	One 10/100/1000Base-T network interface port with RJ-45 connector dedicated to the service processor (SP) on each server node rear panel.
Serial management (SER MGT) port	One RS-232 RJ-45 serial port on each server rear panel.	One RS-232 RJ-45 serial port on each server rear panel.	One RS-232 RJ-45 serial port on each server node rear panel.
VGA port	N/A	N/A	N/A

Component	Oracle Database Appliance X10-S	Oracle Database Appliance X10-L	Oracle Database Appliance X10-HA
Service Processor (SP)	<p>Each server has a service processor with the following features:</p> <ul style="list-style-type: none"> Includes the Baseboard Management Controller (BMC), which supports the industry-standard Intelligent Platform Management Interface (IPMI) feature set. Supports remote KVMs over IP. Supports Ethernet access to SP through a dedicated 10/100/1000Base-T management port and optionally through one of the host GbE ports (sideband management). 	<p>Each server has a service processor with the following features:</p> <ul style="list-style-type: none"> Includes the Baseboard Management Controller (BMC), which supports the industry-standard Intelligent Platform Management Interface (IPMI) feature set. Supports remote KVMs over IP. Supports Ethernet access to SP through a dedicated 10/100/1000Base-T management port and optionally through one of the host GbE ports (sideband management). 	<p>Each server node has a service processor with the following features:</p> <ul style="list-style-type: none"> Includes the Baseboard Management Controller (BMC), which supports the industry-standard Intelligent Platform Management Interface (IPMI) feature set. Supports remote KVMs over IP. Supports Ethernet access to SP through a dedicated 10/100/1000Base-T management port and optionally through one of the host GbE ports (sideband management).
Power supplies	Two hot-pluggable power supplies. The system requires high-line 200-240 VAC sources.	Two hot-pluggable power supplies. The system requires high-line 200-240 VAC sources.	Two hot-pluggable power supplies per server node and per storage shelf. The server nodes requires high-line 200-240 VAC sources. The storage shelf can use 100-127 VAC or 220-240 VAC.
Cooling fans	<p>Four 80-mm, hot-pluggable fan modules per server for chassis cooling. Each fan module contains two counter-rotating fan pairs (four rotors total).</p> <p>Each power supply has its own cooling fans.</p>	<p>Four 80-mm, hot-pluggable fan modules per server for chassis cooling. Each fan module contains two counter-rotating fan pairs (four rotors total).</p> <p>Each power supply has its own cooling fans.</p>	<p>Four 80-mm, hot-pluggable fan modules per server node for chassis cooling. Each fan module contains two counter-rotating fan pairs (four rotors total).</p> <p>Each power supply (server node and storage shelf) has its own cooling fans.</p>
Operating system	Oracle Linux.	Oracle Linux.	Oracle Linux.
Management software	Oracle Integrated Lights Out Manager (ILOM) 5.1.	Oracle Integrated Lights Out Manager (ILOM) 5.1.	Oracle Integrated Lights Out Manager (ILOM) 5.1.

Oracle Database Appliance X10-S/X10-L Front and Back Panels

See views and descriptions of front and back panel features for Oracle Database Appliance X10-S/X10-L.

This section describes Oracle Database Appliance X10-S/X10-L front and back panels. If you have some other Oracle Database Appliance model, select the appropriate link listed in [Overview of Oracle Database Appliance](#).

- [Oracle Database Appliance X10-S/X10-L Front Panel](#)
See an illustration and description of Oracle Database Appliance X10-S/X10-L front panel features.
- [Oracle Database Appliance X10-S/X10-L Back Panel](#)
See an illustration and description of Oracle Database Appliance X10-S/X10-L back panel features.

Oracle Database Appliance X10-S/X10-L Front Panel

See an illustration and description of Oracle Database Appliance X10-S/X10-L front panel features.

Oracle Database Appliance X10-S and Oracle Database Appliance X10-L servers each occupy 2RU.

The following figure shows the components on the front panel of a standard configuration **Oracle Database Appliance X10-S/X10-L**.

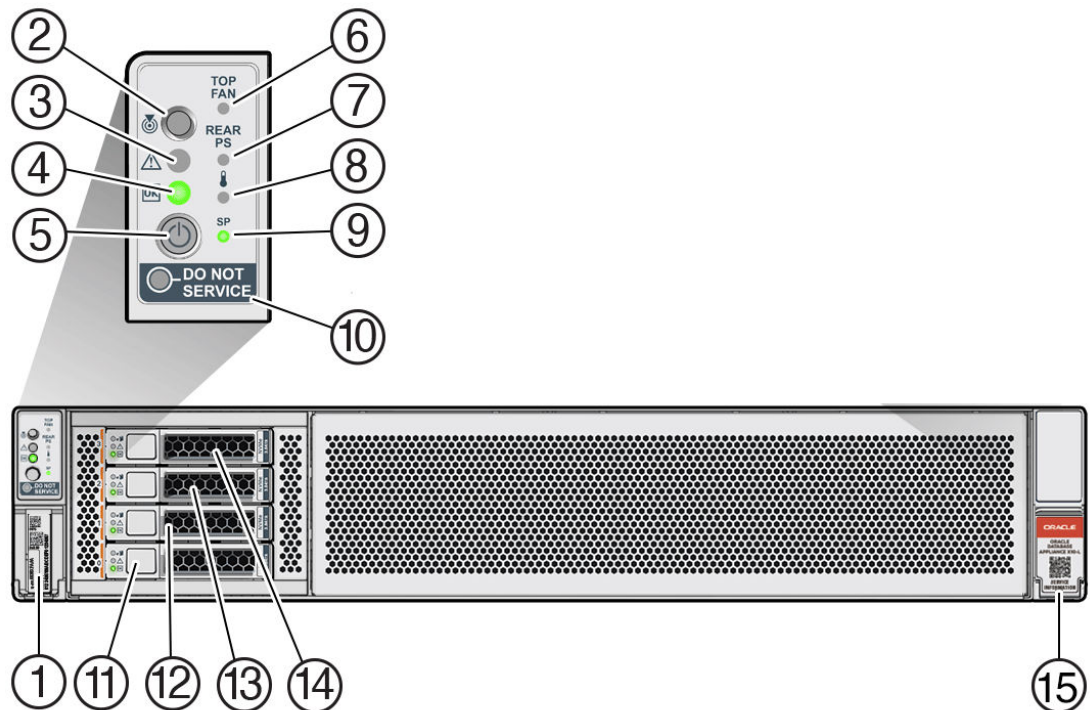

Callout	Description
1	Product Serial Number (PSN) label and Radio Frequency Identification (RFID) tag
2	Locate LED/button: white
3	Service Required LED: amber

Callout	Description
4	Power/OK LED: green
5	Power button
6	Fan Fault LED: amber
7	Power Supply (PS) Fault LED: amber
8	System Over Temperature Warning LED: amber
9	SP OK LED: green
10	DO NOT SERVICE
11 - 14	Front mounted drive slots: NVMe0 in slot 0 (callout 11), NVMe1 in slot 1 (callout 12), NVMe2 in slot 2 (callout 13), NVMe3 in slot 3 (callout 14)

 **Note:**

The Oracle Database Appliance X10-S only has drives in slots 0 and 1. Drive slots 2 and 3 contain filler panels.

Oracle Database Appliance X10-S/X10-L Back Panel

See an illustration and description of Oracle Database Appliance X10-S/X10-L back panel features.

The following figure shows the components on the back panel of an **Oracle Database Appliance X10-S/X10-L**.

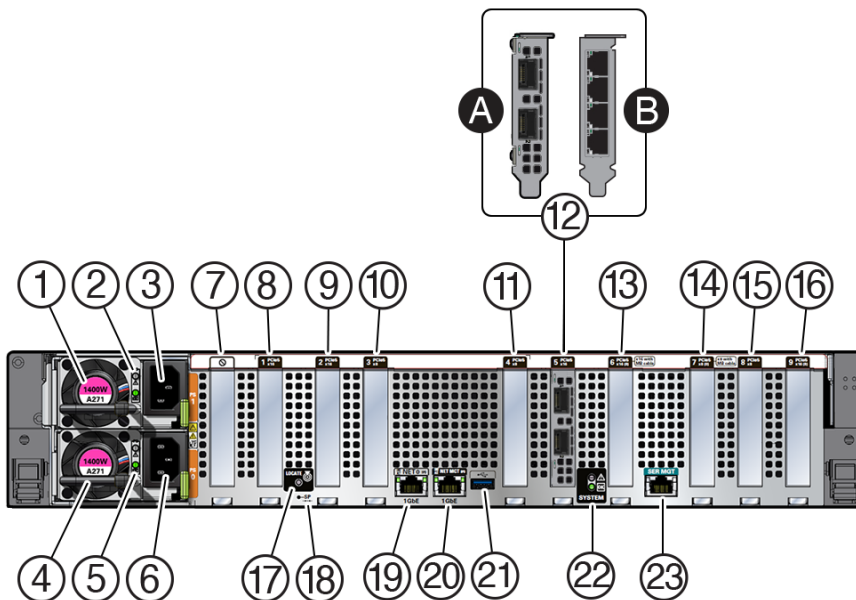

Callout	Description
1	Power Supply (PS) 1 with fan module
2	Power Supply (PS) 1 status indicators: Service Required LED: amber, AC OK LED: green
3	Power Supply 1 (PS1) AC Power Inlet
4	Power Supply (PS) 0 with fan module
5	Power Supply (PS) 0 status indicators: Service Required LED: amber, AC OK LED: green
6	Power Supply 0 (PS0) AC Power Inlet
7	Not used
8	PCIe card slot 1: <ul style="list-style-type: none"> • Oracle Database Appliance X10-S: filler panel • Oracle Database Appliance X10-L: filler panel or optional Oracle Flash Accelerator 680 PCIe Card
9	PCIe card slot 2: <ul style="list-style-type: none"> • Oracle Database Appliance X10-S: filler panel • Oracle Database Appliance X10-L: filler panel or optional Oracle Flash Accelerator 680 PCIe Card
10	PCIe card slot 3: <ul style="list-style-type: none"> • Oracle Database Appliance X10-S: filler panel • Oracle Database Appliance X10-L: filler panel or optional Oracle Flash Accelerator 680 PCIe Card

Callout	Description
11	PCIe card slot 4: <ul style="list-style-type: none"> • Oracle Database Appliance X10-S: filler panel • Oracle Database Appliance X10-L: filler panel, or optional Oracle Dual Port 25Gb Ethernet Adapter, or optional Oracle Quad Port 10GBase-T Adapter
12	PCIe card slot 5: public network interface card <ul style="list-style-type: none"> • Oracle Dual Port 25Gb Ethernet Adapter [12a] --or-- • Oracle Quad Port 10GBase-T Adapter [12b]
13	PCIe card slot 6: Oracle Retimer Card. Slot configured for x16 using a special flyover cable connection from the motherboard.
14	PCIe card slot 7: filler panel (slot is non-functional).
15	PCIe card slot 8: filler panel, or optional Oracle Dual Port 25Gb Ethernet Adapter, or optional Oracle Quad Port 10GBase-T Adapter
16	PCIe card slot 9: <ul style="list-style-type: none"> • Oracle Database Appliance X10-S: filler panel, or optional Oracle Dual Port 25Gb Ethernet Adapter, or optional Oracle Quad Port 10GBase-T Adapter • Oracle Database Appliance X10-L: filler panel or optional Oracle Flash Accelerator 680 PCIe Card
17	System Locate LED: white
18	SP: Reset service processor (SP).
19	NET 0: Network (NET) 1GbE 100/1000BASE-T RJ-45 Gigabit Ethernet (GbE) port
20	NET MGT port: 10/100/1000Base-T network interface port with RJ-45 connector used to connect to the Oracle ILOM service processor
21	USB 3.1 connector
22	System status indicators: Service Required LED: amber, Power/OK LED: green
23	SER MGT port: RJ-45 serial port used to connect to the Oracle ILOM service processor

Oracle Database Appliance X10-HA Front and Back Panels

See views and descriptions of front and back panel features for Oracle Database Appliance X10-HA.

This section describes Oracle Database Appliance X10-HA front and back panels. If you have some other Oracle Database Appliance model, select the appropriate link listed in [Overview of Oracle Database Appliance](#).

- [Oracle Database Appliance X10-HA Front Panel](#)
See an illustration and listing of Oracle Database Appliance X10-HA front panel features.
- [Oracle Database Appliance X10-HA Back Panel](#)
See an illustration and listing of Oracle Database Appliance X10-HA back panel features.

Oracle Database Appliance X10-HA Front Panel

See an illustration and listing of Oracle Database Appliance X10-HA front panel features.

Oracle Database Appliance X10-HA includes two server nodes and an Oracle DE3-24C storage shelf. The entire unit occupies 8RU. The optional storage expansion shelf requires an additional 4RU, increasing the total to 12RU.

The following figure shows the front of **Oracle Database Appliance X10-HA** with an optional storage expansion shelf.

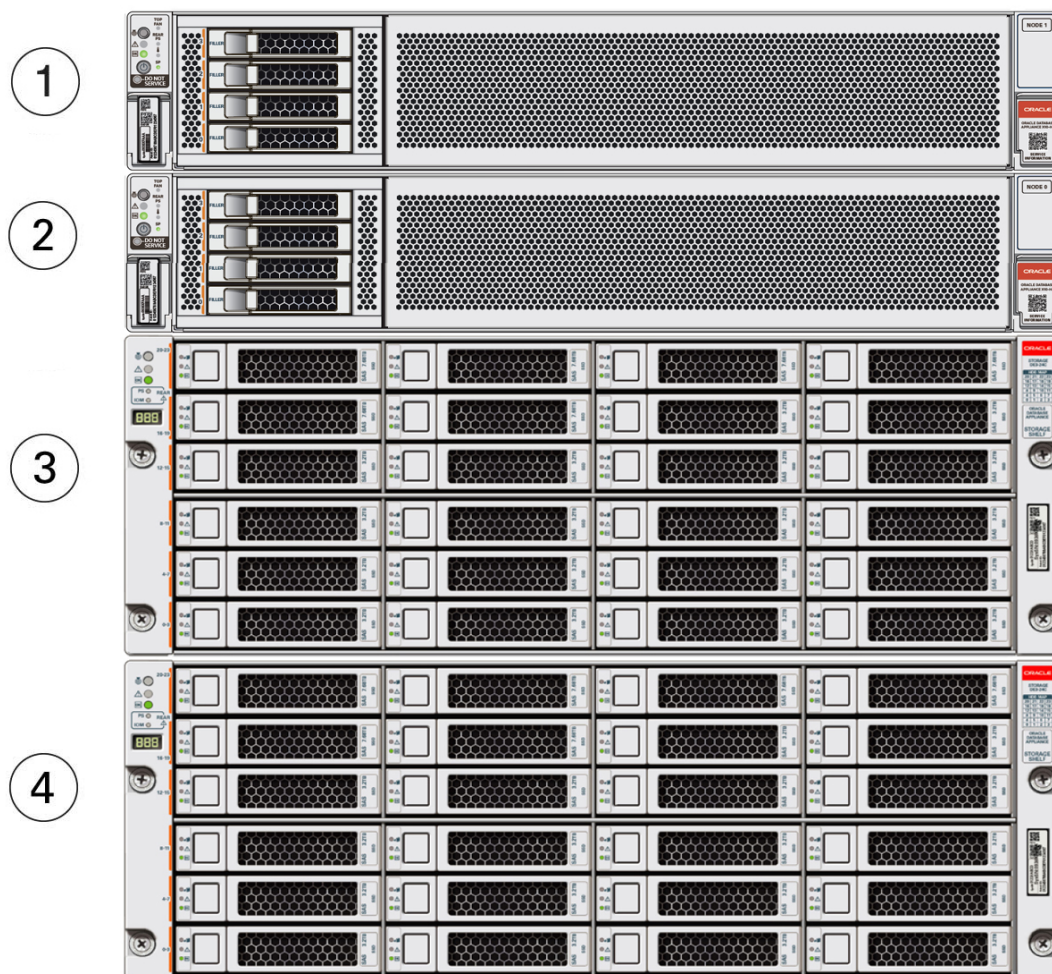

Callout	Description
1	Server node 1
2	Server node 0

Callout	Description
3	Storage shelf (DE3-24C)
4	Optional storage expansion shelf (DE3-24C)

- [Server Node Front Panel Features](#)
See an illustration and listing of Oracle Database Appliance X10-HA server node front panel features.
- [Storage Shelf Front Panel Features](#)
See an illustration and listing of Oracle Database Appliance X10-HA storage shelf front panel features.

Server Node Front Panel Features

See an illustration and listing of Oracle Database Appliance X10-HA server node front panel features.

The following figure shows the components on the front panel of an **Oracle Database Appliance X10-HA server node**.

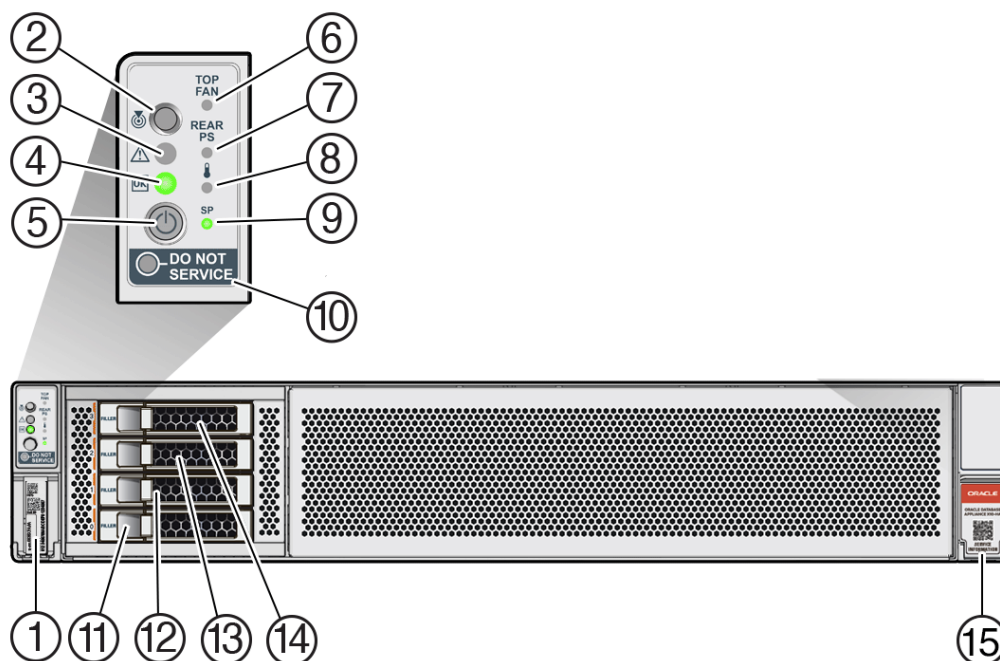

Callout	Description
1	Product Serial Number (PSN) label and Radio Frequency Identification (RFID) tag
2	Locate LED/button: white
3	Service Required LED: amber
4	Power/OK LED: green

Callout	Description
5	Power button
6	Fan Fault LED: amber
7	Power Supply (PS) Fault LED: amber
8	System Over Temperature Warning LED: amber
9	SP OK LED: green
10	DO NOT SERVICE
11 - 14	Front mounted drive slots 0 - 3 (filler panels)
15	Service Information QR Code

 **Note:**

When contacting Oracle Support Services, use the Top Level Identifier (TLI) instead of the serial number. You can find the TLI by looking at the top of either server node or on the top of the storage shelf. For details, see [Technical Support](#).

Storage Shelf Front Panel Features

See an illustration and listing of Oracle Database Appliance X10-HA storage shelf front panel features.

The following figure shows the **Oracle Database Appliance X10-HA storage shelf** front panel features.

 **Note:**

There are three base configurations for the storage shelf: two fully populated and one partially populated (disk slots 6-23 are filler panels). Do not attempt to move or switch disks in the base configurations as it could cause the deployment to fail.

You have the option of upgrading the partially populated base configuration storage shelf to add disks to the empty slots. See [Optional Component Installation](#). Upgrading the base configuration to a fully populated storage shelf will allow you to add a storage expansion shelf later, if needed.

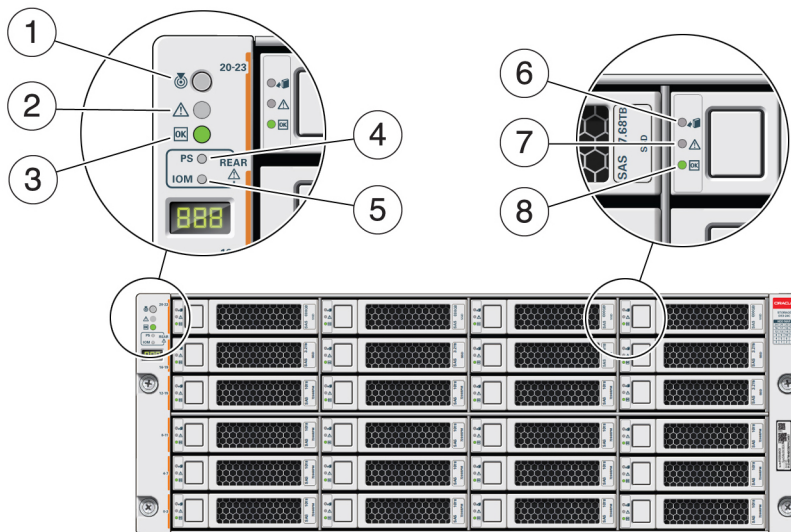

Callout	Description
1	Storage shelf Locate indicator
2	Storage shelf fault indicator
3	Storage shelf OK/power indicator
4	Storage shelf power supply fault indicator
5	Storage shelf IO module fault indicator
6	Drive Ready-to-Remove indicator
7	Drive fault indicator
8	Drive power/activity indicator

Oracle Database Appliance X10-HA Back Panel

See an illustration and listing of Oracle Database Appliance X10-HA back panel features.

This section describes the back panel features for Oracle Database Appliance X10-HA.

The following figure shows the **Oracle Database Appliance X10-HA**.

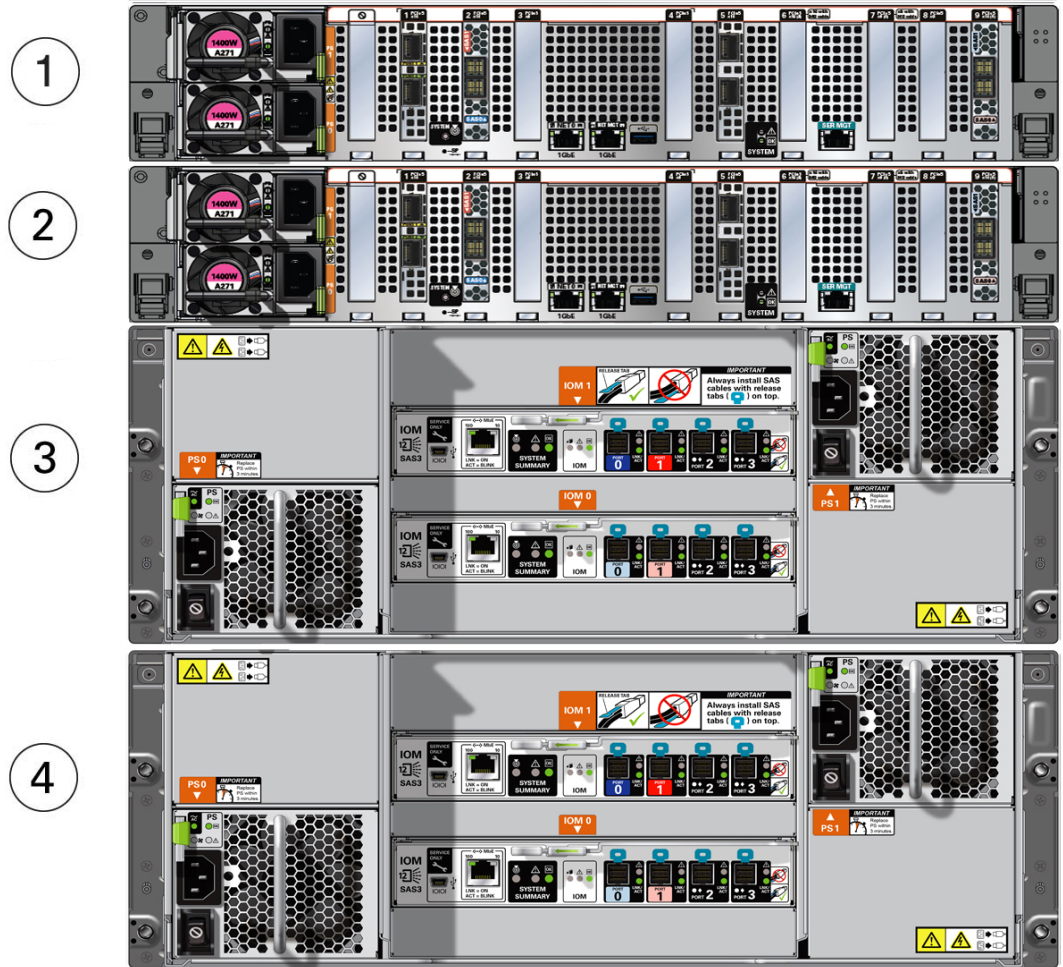

Callout	Description
1	Server node 1
2	Server node 0
3	Storage shelf (DE3-24C)
4	Optional storage expansion shelf (DE3-24C)

- [Server Node Back Panel Features](#)
See an illustration and listing of Oracle Database Appliance X10-HA server node back panel features.
- [Storage Shelf Back Panel Features](#)
See an illustration and listing of Oracle Database Appliance X10-HA storage shelf back panel features.

Server Node Back Panel Features

See an illustration and listing of Oracle Database Appliance X10-HA server node back panel features.

The following figure shows the components on the back panel of an **Oracle Database Appliance X10-HA server node**.

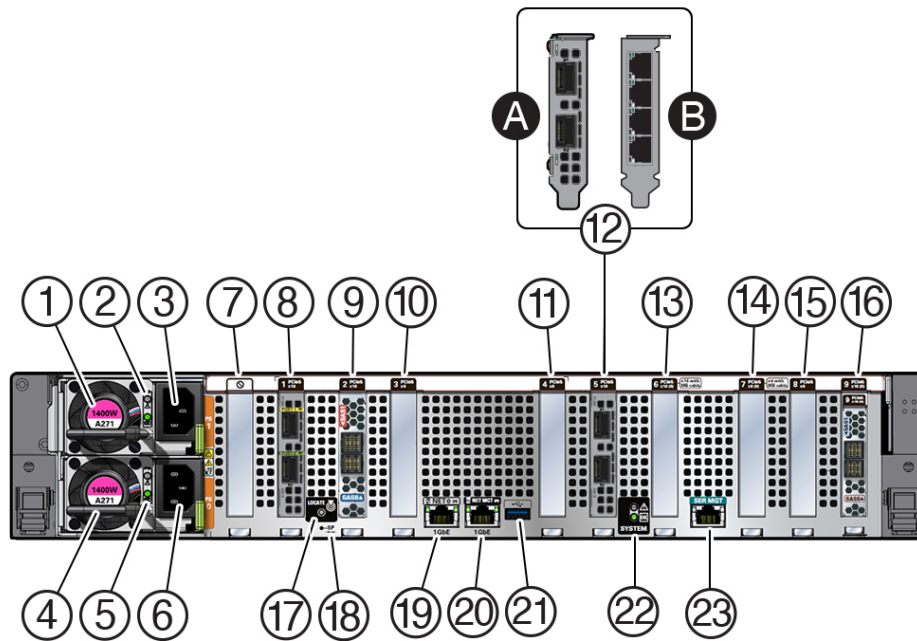

Callout	Description
1	Power Supply (PS) 1 with fan module
2	Power Supply (PS) 1 status indicators: Service Required LED: amber, AC OK LED: green
3	Power Supply (PS) 1 AC power inlet
4	Power Supply (PS) 0 with fan module
5	Power Supply (PS) 0 status indicators: Service Required LED: amber, AC OK LED: green
6	Power Supply (PS) 0 AC power inlet
7	Not used
8	PCIe card slot 1: Oracle Dual Port 25Gb Ethernet Adapter provides two ports with SFP28 connections for a private cluster interconnect between server nodes
9	PCIe card slot 2: provides two SAS3 connectors used to connect the servers to the storage shelf and the storage expansion shelf
10	PCIe card slots 3: filler panel

Callout	Description
11	PCIe card slot 4: filler panel, or optional Oracle Dual Port 25Gb Ethernet Adapter, or optional Oracle Quad Port 10GBase-T Adapter
12	PCIe card slot 5: <ul style="list-style-type: none"> Oracle Dual Port 25Gb Ethernet Adapter [12a] --or-- Oracle Quad Port 10GBase-T Adapter [12b]
13	PCIe card slots 6: filler panel
14	PCIe card slots 7: filler panel
15	PCIe card slot 8: filler panel, or optional Oracle Dual Port 25Gb Ethernet Adapter, or optional Oracle Quad Port 10GBase-T Adapter
16	PCIe card slot 9: provides two SAS3 connectors used to connect the servers to the storage shelf and the storage expansion shelf
17	Locate LED: white
18	SP: Reset service processor (SP)
19	100/1000BASE-T network interface port with RJ-45 connector: NET 0
20	NET MGT port: 10/100/1000Base-T network interface port with RJ-45 connector used to connect to the Oracle ILOM service processor
21	USB 3.1 connector
22	System status indicators: Service Required LED: amber, Power/OK LED: green
23	SER MGT port: RJ-45 serial port used to connect to the Oracle ILOM service processor

Storage Shelf Back Panel Features

See an illustration and listing of Oracle Database Appliance X10-HA storage shelf back panel features.

The following figure shows the **Oracle Database Appliance X10-HA storage shelf** back features.



Note:

The network ports on the storage shelf are intended for use by service engineers only.

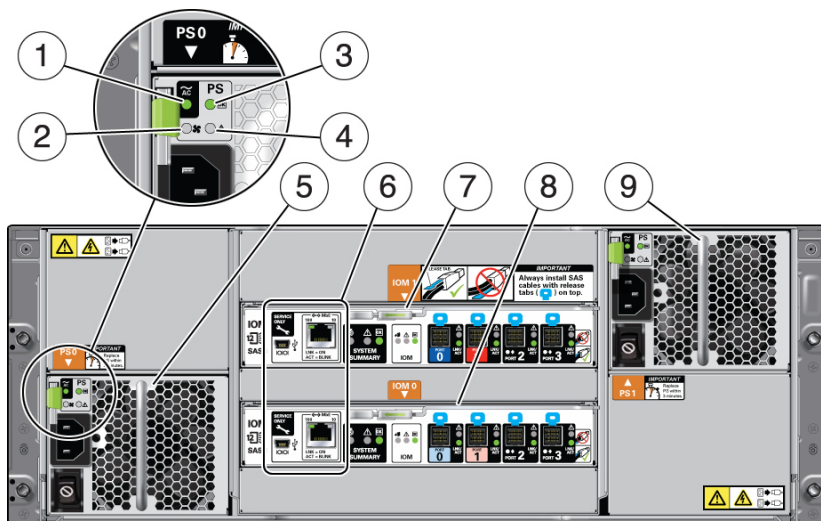

Callout	Description
1	AC power indicator
2	Fan fail indicator
3	Power supply status indicator
4	DC power fail indicator
5	Power Supply with fan module 0
6	Service ports (reserved for Oracle Service only)
7	SAS I/O module 1
8	SAS I/O module 0

Note:
The on/off switch on the power supply is non-functional on this product. The shelf powers on as soon as you plug in AC power.

Callout	Description
9	Power Supply with fan module 1

 **Note:**

The on/off switch on the power supply is non-functional on this product. The shelf powers on as soon as you plug in AC power.

Oracle Database Appliance Specifications

This section describes the physical, electrical and environmental specifications for the various Oracle Database Appliance models.

- [Physical Specifications for Oracle Database Appliance X10 Series](#)
- [Electrical Specifications for Oracle Database Appliance X10 Series](#)
- [Environmental Specifications for Oracle Database Appliance X10 Series](#)

Physical Specifications for Oracle Database Appliance X10 Series

Item	Oracle Database Appliance X10-S	Oracle Database Appliance X10-L	Oracle Database Appliance X10-HA
Height	86.9 mm (3.4 in)	86.9 mm (3.4 in)	86.9 mm (3.4 in) per server node 175 mm (6.9 in) per storage shelf
Width	445 mm (17.5 in)	445 mm (17.5 in)	445 mm (17.5 in) per server node 483 mm (19 in) per storage shelf
Depth	775 mm (30.5 in)	775 mm (30.5 in)	775 mm (30.5 in) per server node 630 mm (24.8 in) per storage shelf
Weight	23.2 kg (51.2 lbs)	27.2 kg (60 lbs), fully populated	23.8 kg (52.5 lbs) per server node 38 kg (84 lbs) per storage shelf

Electrical Specifications for Oracle Database Appliance X10 Series

Item	Oracle Database Appliance X10-S	Oracle Database Appliance X10-L	Oracle Database Appliance X10-HA
Server power supply output rated maximum	1400W at 200-240 VAC, 50/60Hz (47-63 Hz range)	1400W at 200-240 VAC, 50/60Hz (47-63 Hz range)	1400W at 200-240 VAC, 50/60Hz (47-63 Hz range)
Server AC power	10A at 200-240 VAC	10A at 200-240 VAC	10A at 200-240 VAC
Storage shelf power supply output rated maximum	Not applicable	Not applicable	580W at 100-127 VAC 580W at 200-240 VAC
Storage shelf AC Power	Not applicable	Not applicable	8A at 100-127 VAC 3A at 220-240 VAC
Power usage	<ul style="list-style-type: none"> Maximum: 804W, 2,743 BTU/Hr Typical: 459W, 1,566 BTU/Hr 	<ul style="list-style-type: none"> Maximum: 1,159W, 3,955 BTU/Hr Typical: 742W, 2,532 BTU/Hr 	Two server nodes <ul style="list-style-type: none"> Maximum: 2,194W, 7,486 BTU/Hr Typical: 1,394W, 4,757 BTU/Hr Storage shelf (24 SSDs) <ul style="list-style-type: none"> Maximum: 449W, 1,529 BTU/Hr Typical: 276W, 940 BTU/Hr Storage shelf (6 SSDs, 18 HDDs) <ul style="list-style-type: none"> Maximum: 441W, 1,505 BTU/Hr Typical: 256W, 874 BTU/Hr

Environmental Specifications for Oracle Database Appliance X10 Series

Item	Oracle Database Appliance X10-S	Oracle Database Appliance X10-L	Oracle Database Appliance X10-HA
Operating temperature	5° C to 35° C (41° F to 95° F) up to 900 meters (2,953 feet) Optimal: 21°C to 23°C (69.8°F to 73.4°F) Maximum ambient operating temperature is derated by 1 degree C per 300 meters of elevation above 900 meters, to a maximum altitude of 3,000 meters.	5° C to 35° C (41° F to 95° F) up to 900 meters (2,953 feet) Optimal: 21°C to 23°C (69.8°F to 73.4°F) Maximum ambient operating temperature is derated by 1 degree C per 300 meters of elevation above 900 meters, to a maximum altitude of 3,000 meters.	5° C to 35° C (41° F to 95° F) up to 900 meters (2,953 feet) Optimal: 21°C to 23°C (69.8°F to 73.4°F) Maximum ambient operating temperature is derated by 1 degree C per 300 meters of elevation above 900 meters, to a maximum altitude of 3,000 meters.
Nonoperating temperature	-40° C to 68° C (-40° F to 154° F)	-40° C to 68° C (-40° F to 154° F)	-40° C to 68° C (-40° F to 154° F)

Item	Oracle Database Appliance X10-S	Oracle Database Appliance X10-L	Oracle Database Appliance X10-HA
Operating humidity	10% to 90% relative humidity, noncondensing, short term – 5°C to 55°C (23°F to 113°F) 5% to 90% noncondensing, with a maximum of 0.024 kg of water per kg of dry air (0.053 lbs water/2.205 lbs dry air)	10% to 90% relative humidity, noncondensing, short term – 5°C to 55°C (23°F to 113°F) 5% to 90% noncondensing, with a maximum of 0.024 kg of water per kg of dry air (0.053 lbs water/2.205 lbs dry air)	10% to 90% relative humidity, noncondensing, short term – 5°C to 55°C (23°F to 113°F) 5% to 90% noncondensing, with a maximum of 0.024 kg of water per kg of dry air (0.053 lbs water/2.205 lbs dry air)
Nonoperating humidity	Maximum wet bulb of 93% noncondensing 35°C (95°F)	Maximum wet bulb of 93% noncondensing 35°C (95°F)	Maximum wet bulb of 93% noncondensing 35°C (95°F)
Operating altitude	Up to 3,000 m* (9,840 ft); maximum ambient temperature is derated by 1° C per 300 m above 900 m * Except in China markets where regulations might limit installations to a maximum altitude of 2,000 m (6,560 ft)	Up to 3,000 m* (9,840 ft); maximum ambient temperature is derated by 1° C per 300 m above 900 m * Except in China where regulations might limit installations to a maximum altitude of 2,000 m (6,560 ft)	Up to 3,000 m* (9,840 ft); maximum ambient temperature is derated by 1° C per 300 m above 900 m * Except in China where regulations might limit installations to a maximum altitude of 2,000 m (6,560 ft)
Nonoperating altitude	Up to 12,000 m (39,370 ft)	Up to 12,000 m (39,370 ft)	Up to 12,000 m (39,370 ft)
Acoustic noise	Fan speed % Pulse Width Modulation (PWM) Acoustic noise emission declaration based on the measured Sound Power LWAd (1Bel = 10 dB) Sound Power (Bels): 50% PWM = 8.4, 60% PWM = 8.8, 70% PWM = 9.1, 80% PWM = 9.6, 90% PWM = 9.8, 100% PWM = 10.1	Fan speed % Pulse Width Modulation (PWM) Acoustic noise emission declaration based on the measured Sound Power LWAd (1Bel = 10 dB) Sound Power (Bels): 50% PWM = 8.4, 60% PWM = 8.8, 70% PWM = 9.1, 80% PWM = 9.6, 90% PWM = 9.8, 100% PWM = 10.1	Fan speed % Pulse Width Modulation (PWM) Acoustic noise emission declaration based on the measured Sound Power LWAd (1Bel = 10 dB) Sound Power (Bels): 50% PWM = 8.5, 60% PWM = 8.8, 70% PWM = 9.1, 80% PWM = 9.6, 90% PWM = 9.8, 100% PWM = 10.1

Technical Support

How to obtain technical support for your appliance.

For technical support, go to:

<https://support.oracle.com/portal/>

Oracle Database Appliance X10-S/X10-L

Report the serial number located on the front panel of the system, the top of the system, or on the Customer Information Sheet that is shipped with the system.

You only need to extend the server node a couple of inches on its slide rails to see the serial label on the top of the system. You do not need to release any cables, or slide it to the extended maintenance position.

Oracle Database Appliance X10-HA

Report the Top Level Identifier (TLI). To see the TLI, look on the Customer Information Sheet or look at the top of a server node or storage shelf on the left-hand side towards the front.

The TLI part number and TLI serial number are the same for the factory-bundled server nodes of an appliance. The following figure shows an example Top Level Identifier label:

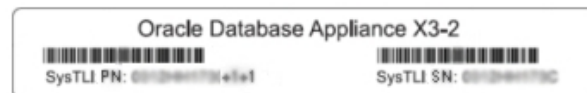

If the appliance is in a rack where you cannot see the TLI, do one of the following:

- Look on another component (server node or storage shelf) of the appliance. All factory-bundled server nodes of Oracle Database Appliance have the same TLI numbers.
- Slide a server node partway out on its rails, just far enough to see the TLI. See the *Service Manual* for details.

You only need to extend the server node a couple of inches on its slide rails to see the TLI. You do not need to release any cables, or slide it to the extended maintenance position.

3

Site Preparation

Learn about site preparation requirements for the Oracle Database Appliance *before* installing it into a rack and cabling it.

- [Prepare Your Site](#)
Use this procedure before installing the appliance into a rack.

Prepare Your Site

Use this procedure before installing the appliance into a rack.

1. Ensure that your site meets the environmental requirements in [Environmental Specifications](#).
2. Ensure that your site meets the electrical specifications in [Electrical Specifications](#).
3. Ensure that your site has adequate clearance for the shipping containers.
4. Allow the equipment to acclimatize to the computer center environment.

If significant temperature differences exist (> 10° C / 18° F) between the new system and the designated computer center, the equipment should be left in its boxes for a sufficient period of time to allow the temperature of the equipment to come to within a few degrees of the computer center.

 **Caution:**

Equipment damage. The system should never be powered on unless it is within the supported operating range (temperature and humidity).

5. Open the shipping containers.

You should do this at the location where the system will be installed, but outside of the computer center itself.

 **Caution:**

Equipment damage. Use a separate area in which to remove the packaging material to reduce particle contamination before entering the computer center.

6. Check the contents of the shipping container.

▲ Caution:

System failure. All items in a shipment are designed to be used together as a single system. Do not mix components from different shipments; this could cause the system to fail.

It should contain:

Oracle Database Appliance X10-S/X10-L	Oracle Database Appliance X10-HA
<ul style="list-style-type: none">• Preconfigured system• Accessory kit, including:<ul style="list-style-type: none">– Setup poster– Safety and legal documentation– Rackmount guide and alignment template– Rackmount kit• Power cords (shipped separately)• Shipping kit (optional)	<ul style="list-style-type: none">• The server nodes include:<ul style="list-style-type: none">– Preconfigured server nodes (0 and 1)– Accessory kit, including:<ul style="list-style-type: none">* Setup poster* Safety and legal documentation* Rackmount guide and alignment template* Rackmount kit* Power cords* SAS cables, Ethernet cables, cluster cables, and labels are shipped with the storage shelf.• The storage shelf includes:<ul style="list-style-type: none">– Preconfigured storage shelf– Rackmount kit– Power cords– Cables– Setup poster• If you ordered a storage expansion shelf, it is shipped separately and includes the same list of components as the storage shelf.

4

Installing Oracle Database Appliance Into a Rack

Complete the following procedures to install the Oracle Database Appliance into a rack.

- [Task Overview](#)
Tasks to perform when installing various models of Oracle Database Appliance into a rack.
- [Optional Component Installation](#)
Learn about the optional components supported for the various Oracle Database Appliance models.
- [Safety Precautions When Rackmounting](#)
Learn about safety precautions during rack installation for Oracle Database Appliance.
- [ESD Precautions](#)
Learn about electrostatic discharge precautions during rack installation for Oracle Database Appliance.
- [Rack Compatibility Requirements](#)
Learn about the basic racking requirements for installing Oracle Database Appliance.
- [Installing the System Into a Rack](#)
Procedures describing how to install the various Oracle Database Appliance models into a rack.

Task Overview

Tasks to perform when installing various models of Oracle Database Appliance into a rack.

Follow the appropriate procedures to rack mount your system.



Note:

These procedures describe how to install the appliance into a rack. For cabling instructions, refer to the *Deployment and User's Guide*.

Oracle Database Appliance X10-S/X10-L	Oracle Database Appliance X10-HA
<ul style="list-style-type: none"> Optional Component Installation Safety Precautions When Rackmounting ESD Precautions Rack Compatibility Requirements Contents of the Shipping Container Tools and Equipment Needed Stabilize the Rack for Installation Server Rackmount Kit Contents Install Mounting Brackets on the Server Mark the Rackmount Location Attach the AC Power Cables and Server Slide-Rails to the Rack Install the Server Into the Slide-Rail Assemblies Install the Cable Management Arm (Optional) 	<ul style="list-style-type: none"> Optional Component Installation Safety Precautions When Rackmounting ESD Precautions Rack Compatibility Requirements Contents of the Shipping Pallet Installation Sequence Verify Component Compatibility Tools and Equipment Needed Stabilize the Rack for Installation Applying Labels Installing the Storage Shelves Into a Rack Add a Storage Expansion Shelf to an Existing System Server Rackmount Kit Contents Install Mounting Brackets on the Server Mark the Rackmount Location Attach the AC Power Cables and Server Slide-Rails to the Rack Install the Server Into the Slide-Rail Assemblies Install the Cable Management Arm (Optional)

Optional Component Installation

Learn about the optional components supported for the various Oracle Database Appliance models.

Optional components can be purchased independent of the factory configuration and are shipped separately. Where possible, optional components should be installed before you install the server in a rack.

- **DIMM memory kits:**
 - For **Oracle Database Appliance X10-S**, which comes with 256 GB (four 64 GB registered DIMMs), you have the option of expanding to 512 GB or 768 GB. Memory kits come in sets of four 64 GB registered DIMMs.
 - For **Oracle Database Appliance X10-L**, which comes with 512 GB (eight 64 GB registered DIMMs), you have the option of expanding to 1 TB or 1.5 TB. Memory kits come in sets of four 64 GB registered DIMMs. DIMM slots for both processors must be identically populated.
 - For **Oracle Database Appliance X10-HA**, which comes with 512 GB (eight x 64 GB registered DIMMs per server node), you have the option of ordering memory expansion to 1 TB or 1.5 TB per server node. Memory kits come in sets of four 64 GB registered DIMMs. DIMM slots for both server nodes must be identically populated.

Refer to the *Service Manual* for instructions on installing memory.

- **Storage drives:**
 - For **Oracle Database Appliance X10-L** with the default configuration of two front-mounted small form factor (SFF) NVMe drives, you have the option of ordering two additional 2.5-inch 6.8 TB NVMe SSDs for front drive slots 2-3. Drives must be installed in pairs.

- For **Oracle Database Appliance X10-HA**, you have the following options:
 - * If your base configuration includes a partially populated storage shelf, you can upgrade it as follows:
 - * For a high performance shelf, you can add up to eighteen 7.68 TB SSDs (available in six-packs). You can add storage with the system running and use the appliance CLI software commands to expand the storage configuration.
 - * For a high capacity shelf, you can add eighteen 22 TB HDDs (available in an eighteen-pack). You must power off the appliance, add storage, then re-image and redeploy the appliance software. This is required to reconfigure the appliance from the default high performance mode to high capacity mode.
 - * An additional storage shelf can be added if your existing appliance storage shelf came fully populated, or you expanded your partially populated base storage shelf configuration of six 7.68 TB SSDs with either eighteen 7.68 TB SSDs or eighteen 22 TB HDDs. You can add a storage expansion shelf with the system running and use the appliance CLI software commands to expand the storage configuration.

 **Note:**

You **cannot** add a storage expansion shelf (which comes fully populated) unless your existing storage shelf is fully populated and the storage shelf you purchase is configured identically (same drives in same slots) to your existing storage shelf.

Refer to the *Service Manual* for instructions on installing storage drives.

- **Optional PCIe add-in card (AIC) storage:**

For **Oracle Database Appliance X10-L**, you have the option of ordering up to four Oracle Flash Accelerator 680 PCIe Cards per system.

 **Note:**

Before installing Oracle Flash Accelerator 680 PCIe Cards in the system, you must first ensure that all four front-mounted SFF NVMe drive slots are populated.

Refer to the *Service Manual* for instructions on installing PCIe cards. After the card is replaced, refer to the *Deployment and User's Guide* for instructions on software configuration.

- **Optional network cards:**

For **Oracle Database Appliance X10** series, you have the option of ordering up to two additional public network PCIe cards per system (or per node for the X10-HA). Supported network cards include the Oracle Dual Port 25Gb Ethernet Adapter and the Oracle Quad Port 10GBase-T Adapter. Additional public network cards do not need to match public network cards (type and model) already installed.

 **Note:**

If you intend on replacing public network cards already in the system, you need to follow the instructions in the *Deployment and User's Guide* to delete the existing network card and interface via software. **You cannot replace the factory installed public network card in PCIe slot 5 or the cluster interconnect card in PCIe slot 1.**

Refer to the *Service Manual* for instructions on installing PCIe cards. After the card is replaced, refer to the *Deployment and User's Guide* for instructions on cabling and software configuration.

Safety Precautions When Rackmounting

Learn about safety precautions during rack installation for Oracle Database Appliance.

This section describes safety precautions you must follow when installing the server into a rack.

 **Caution:**

Personal injury or equipment damage. Prevent the rack from tipping over. 1) Deploy the anti-tilt bar or legs on the equipment rack before beginning an installation. 2) Always load equipment into a rack from the bottom up so that the rack will not become top-heavy and tip over. 3) Mount equipment in the rack such that it does not create uneven or dangerous mechanical loading. 4) Do not use slide-rail mounted equipment as a shelf or workspace.

 **Caution:**

Equipment damage caused by elevated temperature. 1) If you install the equipment in a closed or multi-unit rack assembly, ensure that the operating ambient temperature inside the rack does not exceed the maximum ambient temperature specified for the server. For server environmental requirements, see [Environmental Specifications](#). 2) Install the equipment in the rack such that airflow is not restricted or impeded.

 **Caution:**

Supply circuit damage and data loss. The AC circuits used to supply power to the system must be rated for the maximum amount of power that the system requires. See [Electrical Specifications](#) for input power requirements.

▲ Caution:

Equipment damage. Maintain reliable earthing. Pay particular attention to supply connections other than direct connections to the branch circuit (for example, use of power strips).

▲ Caution:

Equipment damage. The shipping brackets used to secure the rack cabinet to the shipping pallet are not for use in the data center for bracing or anchoring the rack cabinet during seismic events.

ESD Precautions

Learn about electrostatic discharge precautions during rack installation for Oracle Database Appliance.

▲ Caution:

Equipment damage. To prevent damage from electrostatic discharge, use the following precautions when installing or servicing components.

- Place components on an antistatic surface, such as an antistatic discharge mat, an antistatic bag, or a disposable antistatic mat.
- Wear an antistatic grounding strap connected to a metal surface on the chassis when you work on system components.

Rack Compatibility Requirements

Learn about the basic racking requirements for installing Oracle Database Appliance.

The rack-mounting hardware can be used only in specialized racks that meet the requirements in the following table.

Feature	Oracle Database Appliance X10-S/X10-L	Oracle Database Appliance X10-HA
Rack structure	Four-post rack (mounting at both front and back). Supported rack types: square hole (9.5 mm) and round hole (M6 or 1/4-20 threaded only). Two-post racks are not compatible.	Four-post rack (mounting at both front and back). Supported rack types: square hole (9.5 mm) and round hole (M6 or 1/4-20 threaded only). Two-post racks are not compatible.

Feature	Oracle Database Appliance X10-S/X10-L	Oracle Database Appliance X10-HA
Space available	Must have 2RU (rack units) of space available.	8RU without optional storage expansion shelf. 12RU with optional storage expansion shelf.
Rack horizontal opening and unit vertical pitch	Conforms to ANSI/EIA 310-D-1992 or IEC 60297 standards.	Conforms to ANSI/EIA 310-D-1992 or IEC 60297 standards.
Distance between front and rear mounting planes	Minimum 610 mm and maximum 915 mm (24 in to 36 in).	Minimum 610 mm and maximum 915 mm (24 in to 36 in).
Clearance depth in front of front mounting plane	Distance to front cabinet door is at least 25.4 mm (1 in).	Distance to front cabinet door is at least 25.4 mm (1 in).
Clearance depth behind front mounting plane	Distance to rear cabinet door is at least 900 mm (35.43 in) with the cable management arm, or 800 mm (31.5 in) without the cable management arm.	Distance to rear cabinet door is at least 900 mm (35.43 in) with the cable management arm, or 800 mm (31.5 in) without the cable management arm.
Clearance width between front and rear mounting planes	Distance between structural supports and cable troughs is at least 456 mm (18 in).	Distance between structural supports and cable troughs is at least 456 mm (18 in).
Minimum clearance for service access	Front clearance: 123.2 cm (48.5 in) Rear clearance: 91 cm (36 in)	Front clearance: 123.2 cm (48.5 in) Rear clearance: 91 cm (36 in)
Server node dimensions	Physical Specifications for Oracle Database Appliance X10 Series	Physical Specifications for Oracle Database Appliance X10 Series
Storage shelf dimensions	N/A	Physical Specifications for Oracle Database Appliance X10 Series

Installing the System Into a Rack

Procedures describing how to install the various Oracle Database Appliance models into a rack.

▲ Caution:

Personal injury or equipment damage. Always load equipment into a rack from the bottom up so that it will not become top-heavy and tip over. Deploy your rack's anti-tilt bar to prevent the rack from tilting during equipment installation.

- [Installing Oracle Database Appliance X10-S/X10-L Into a Rack](#)
Procedures describing how to install Oracle Database Appliance X10-S/X10-L into a rack.
- [Installing Oracle Database Appliance X10-HA Into a Rack](#)
Procedures describing how to install Oracle Database Appliance X10-HA into a rack.

Installing Oracle Database Appliance X10-S/X10-L Into a Rack

Procedures describing how to install Oracle Database Appliance X10-S/X10-L into a rack.

- [Contents of the Shipping Container](#)
- [Tools and Equipment Needed](#)
- [Stabilize the Rack for Installation](#)
- [Rackmount Kit Contents](#)
- [Install Mounting Brackets on the Server](#)
- [Mark the Rackmount Location](#)
- [Attach the AC Power Cables and Server Slide-Rails to the Rack](#)
- [Install the Server Into the Slide-Rail Assemblies](#)
- [Install the Cable Management Arm \(Optional\)](#)

Contents of the Shipping Container

Inspect the shipping cartons of your Oracle Database Appliance system for evidence of physical damage. If a shipping carton appears damaged, request that the carrier's agent be present when the carton is opened. Keep all contents and packing material for the agent's inspection.

The ship kit for the server includes the following items:

- Power cords, packaged separately with country kit
- Rail kit containing rack rails, hardware, template and installation instructions
- Miscellaneous hardware, cables, and connectors
- Setup booklet
- Legal and safety documents

Tools and Equipment Needed

Obtain the following tools and equipment before beginning the installation of Oracle Database Appliance.

- Phillips head No. 2 screwdriver that is a minimum of 4 inches long
- T20 Torx driver if using a threaded rack
- A mechanical lift is highly recommended

Stabilize the Rack for Installation

 **Caution:**

Personal injury or equipment damage. To reduce the risk of personal injury, stabilize the rack cabinet, and extend all anti-tilt devices before installing the server.

Refer to your rack cabinet documentation for more detailed instructions.

1. When unpacking at the installation site, verify that the rack cabinet leveling feet are up before moving the rack cabinet.
2. Remove the front and rear doors of the rack cabinet if they interfere with the installation.
3. To prevent the rack cabinet from tipping during the installation, fully extend the rack cabinet's anti-tilt legs or anti-tilt bar, which are located at the bottom front of the rack cabinet.
4. If there are leveling feet beneath the rack cabinet to prevent it from rolling, extend these leveling feet fully downward to the floor once the rack cabinet is where it will reside in the data center.
5. When moving a rack cabinet to a different location, including repacking, verify that rack cabinet leveling feet are up before moving the rack cabinet.

Rackmount Kit Contents

The following figure shows the Rackmount Kit contents. For additional instructions on how to install your server in a four-post rack using the slide-rail and cable management arm options, refer to the Rackmounting Template.

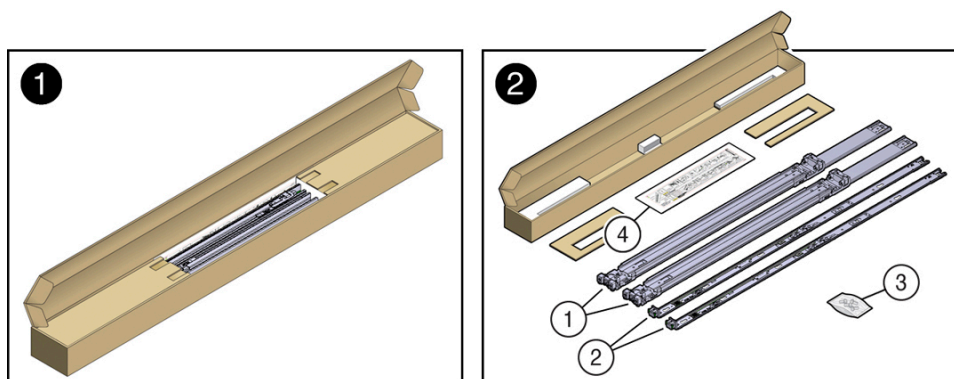

Call Out	Description
1	Slide-rails
2	Mounting brackets
3	Four M4 x 5 fine-pitch mounting bracket securing screws (optional)
4	Rackmounting Template

Install Mounting Brackets on the Server

To install the mounting brackets on the sides of the server:

1. Position a mounting bracket against the chassis so that the slide-rail lock is at the server front, and the five keyhole openings on the mounting bracket are aligned with the five locating pins on the side of the chassis.

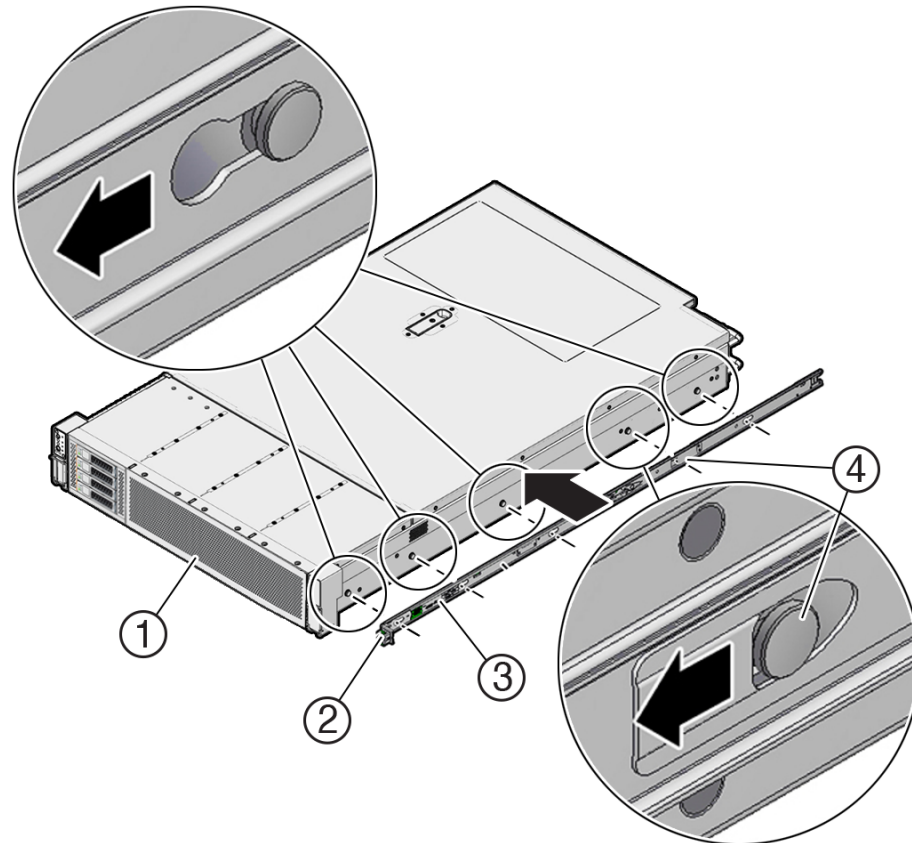

Call Out	Description
1	Chassis front
2	Slide-rail lock
3	Mounting bracket
4	Mounting bracket clip

2. When the heads of the five chassis locating pins protrude through the five keyhole openings in the mounting bracket, pull the mounting bracket toward the front of the chassis until the mounting bracket clip locks into place with an audible click.
3. Verify that the back locating pin is engaged with the mounting bracket clip.
4. Repeat Step 1 through Step 3 to install the other mounting bracket on the other side of the server.

Mark the Rackmount Location

Identify the location in the rack where you want to place the server. Oracle Database Appliance server requires two rack units (2U). Use the Rackmounting Template to identify the correct mounting holes for the slide-rails.

▲ Caution:

Always load equipment into a rack from the bottom up so that the rack does not become top-heavy and tip over. Extend the rack anti-tilt bar to prevent the rack from tipping during equipment installation.

1. Ensure that there is at least two rack units (2U) of vertical space in the rack cabinet to install the server. See [Rack Compatibility](#).
2. Place the Rackmounting Template against the front rails, and measure up from the bottom of the Rackmounting Template. The bottom edge of the Rackmounting Template card corresponds to the bottom edge of the server.

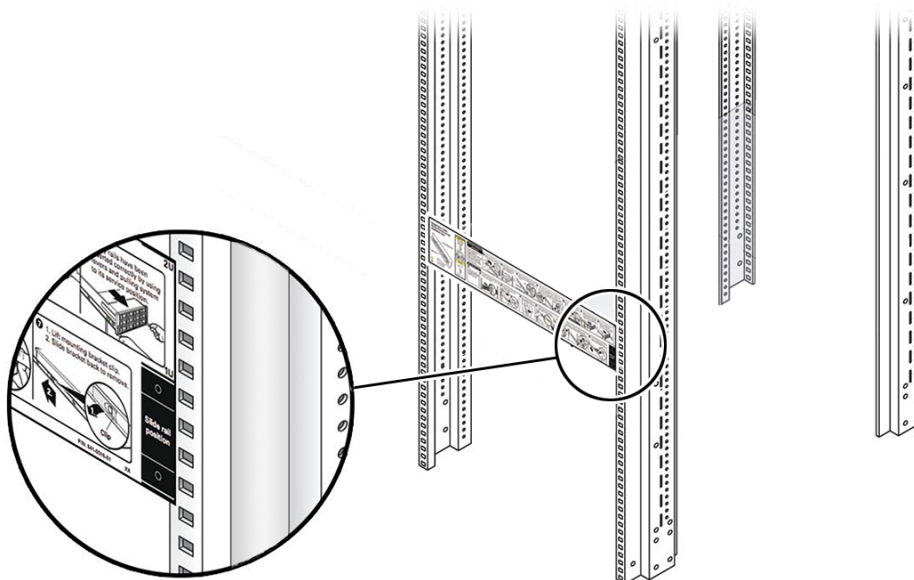

3. Mark the mounting holes for the front slide-rails.

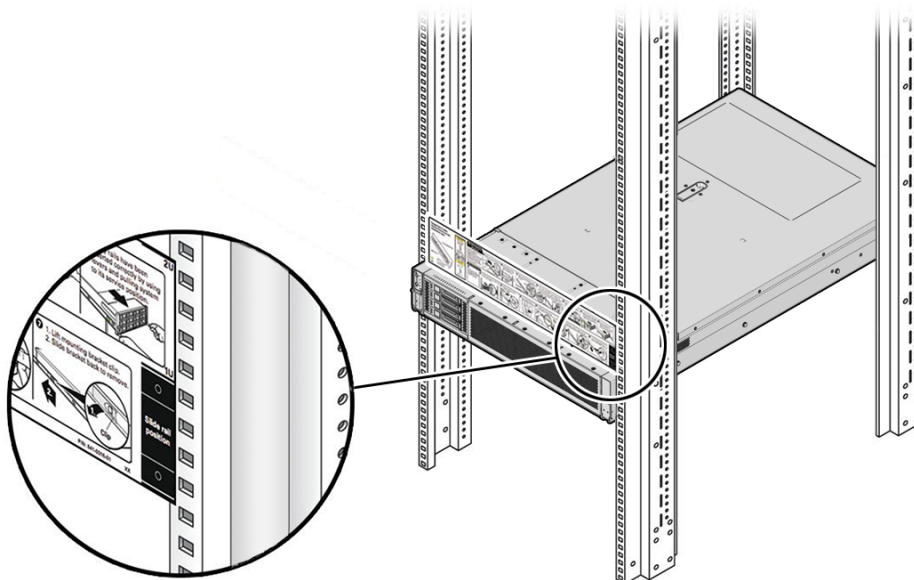

4. Mark the mounting holes for the back slide-rails.

Attach the AC Power Cables and Server Slide-Rails to the Rack

Use this procedure to attach the server slide-rail assemblies to the rack.

Note:

Be sure to install the server right-angle AC power cables that came with your system. In some racks, the standard rail kit slide-rails obstructs access to the front of the Power Distribution Unit (PDU) electrical sockets. Plug in your AC power cables into the PDU first, and then install the slide-rails into the rack. After you install the slide-rails, you cannot disconnect or remove the standard AC power cables from the PDU, but you can remove them from the system power supply.

1. Before you install the server slide-rails into the rack, install the right-angle end of the AC power cables that came with the system into the left-side and right-side rack PDU electrical sockets.

Note:

Splitting AC power cords between the left and right rack PDUs allows for devices that have redundant power supplies to plug the primary power supply into one PDU and the secondary (redundant) power supply into a different PDU, increasing redundancy.

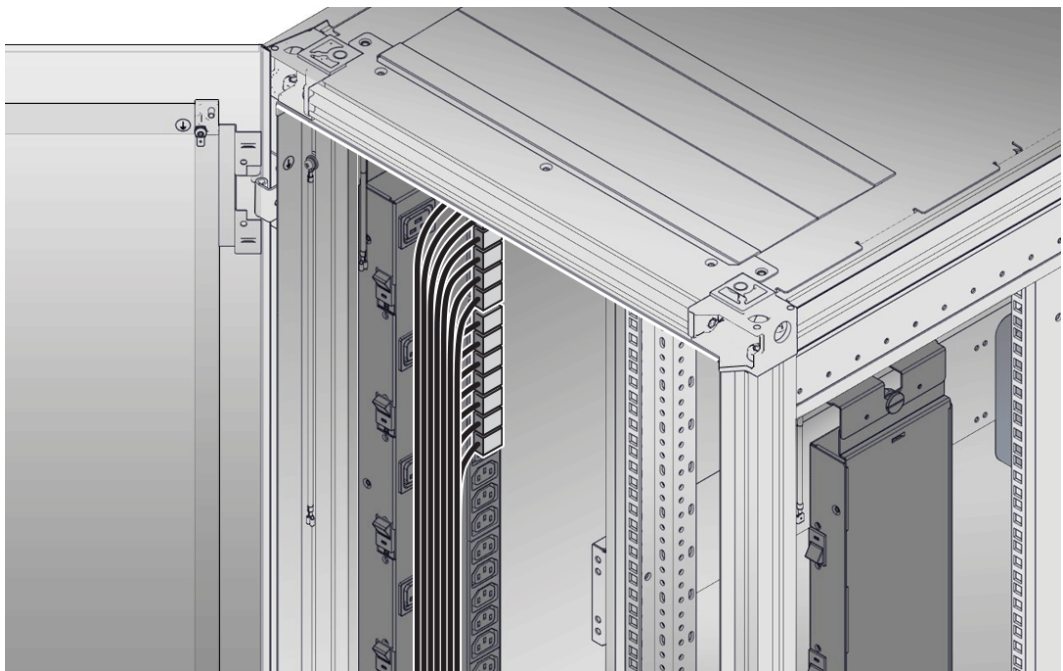

2. Orient the system slide-rail assembly so that the ball-bearing track is forward and locked in place.

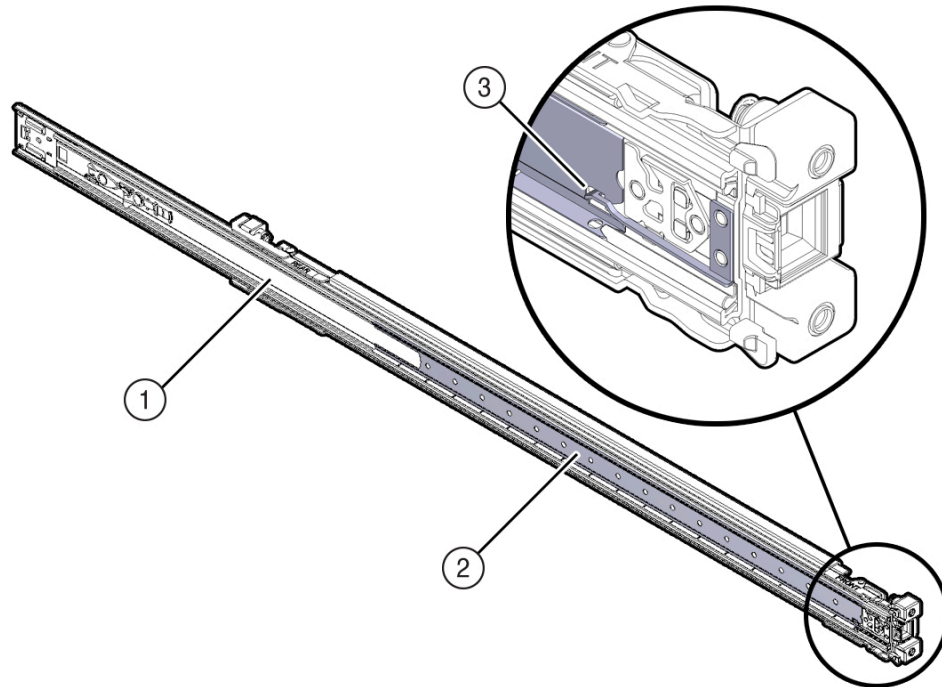

Call Out	Description
1	Slide-rail
2	Ball-bearing track
3	Ball-bearing locking mechanism

3. Starting with either the left or right side of the rack, align the back of the slide-rail assembly against the inside of the back rack rail, and push until the assembly locks into place with an audible click.

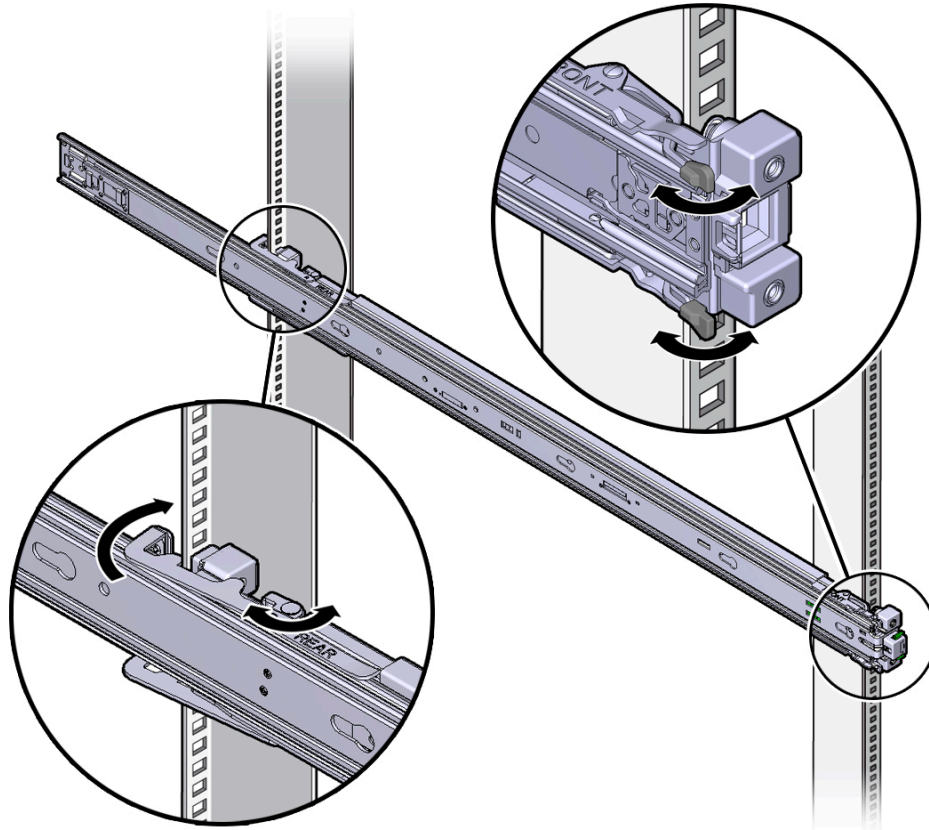

4. Align the front of the slide-rail assembly against the outside of the front rack rail, and push until the assembly locks into place with an audible click.
5. Repeat Step 2 through Step 4 to attach the slide-rail assembly to the other side of the rack.

Install the Server Into the Slide-Rail Assemblies

Use this procedure to install the server chassis with mounting brackets into the slide-rail assemblies that are mounted to the rack.

▲ Caution:

Personal Injury or Equipment Damage: This procedure requires a minimum of two people because of the weight of the server. Attempting this procedure alone could result in equipment damage or personal injury.

Always load equipment into a rack from the bottom up so that the rack does not become top-heavy and tip over. Extend the rack anti-tilt bar to prevent the rack from tipping during equipment installation.

1. If you haven't already done so, fully extend the rack cabinet's anti-tilt bar located at the bottom front of the rack cabinet.
2. Push the slide-rails as far as possible into the slide-rail assemblies in the rack.

3. Position the server so that the back ends of the mounting brackets are aligned with the slide-rail assemblies that are mounted in the rack.
4. Insert the mounting brackets into the slide-rails, and then push the server into the rack until the mounting brackets are flush with the slide-rail stops (approximately 30 cm or 12 inches).

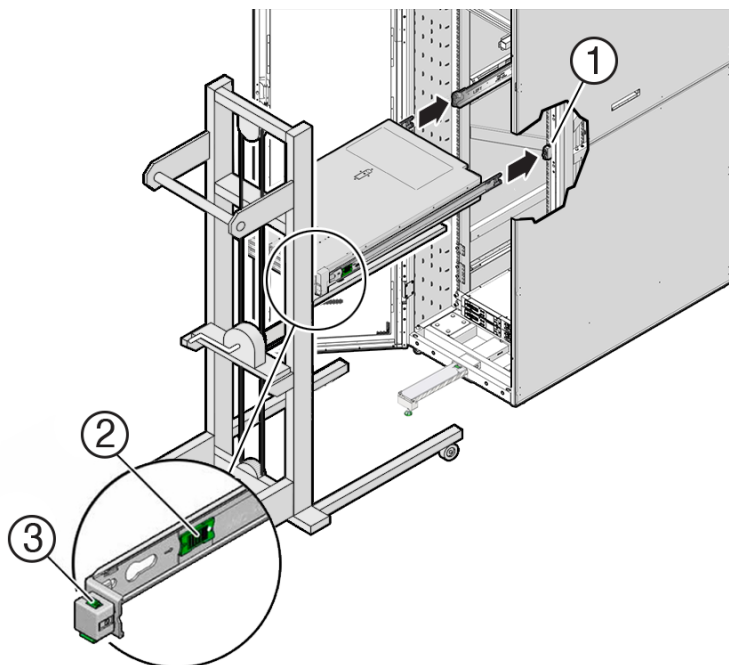

Call Out	Description
----------	-------------

- | | |
|---|--|
| 1 | Inserting mounting bracket into slide-rail |
| 2 | Slide-rail release button |
| 3 | Slide-rail lock |
-

5. Simultaneously push and hold the green slide-rail release buttons on each mounting bracket while you push the server into the rack. Continue pushing the server into the rack until the slide-rail locks (on the front of the mounting brackets) engage the slide-rail assemblies with an audible click.

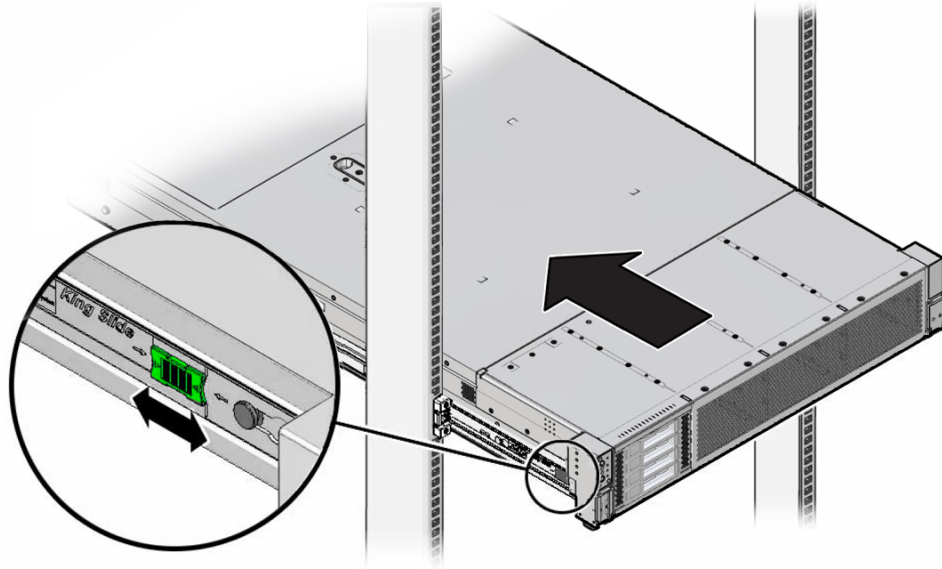

▲ Caution:

Before you install the optional cable management arm verify that the server is securely mounted in the rack and that the slide-rail locks are engaged with the mounting brackets.

6. Do one of the following:
 - If you purchased the optional cable management arm, proceed to the next section.
 - If you did not purchase the optional cable management arm, retract the rack anti-tilt mechanism back to its normal position and plug in AC power to the system.

Install the Cable Management Arm (Optional)

Follow this procedure to install the cable management arm (CMA), which you can use to manage cables connected to the back of the server.

✎ Note:

Before you install the CMA, ensure that the right-angle AC power cables are long enough to connect to the rackmounted servers when routed through the CMA.

1. Unpack the CMA, which contains the following components.

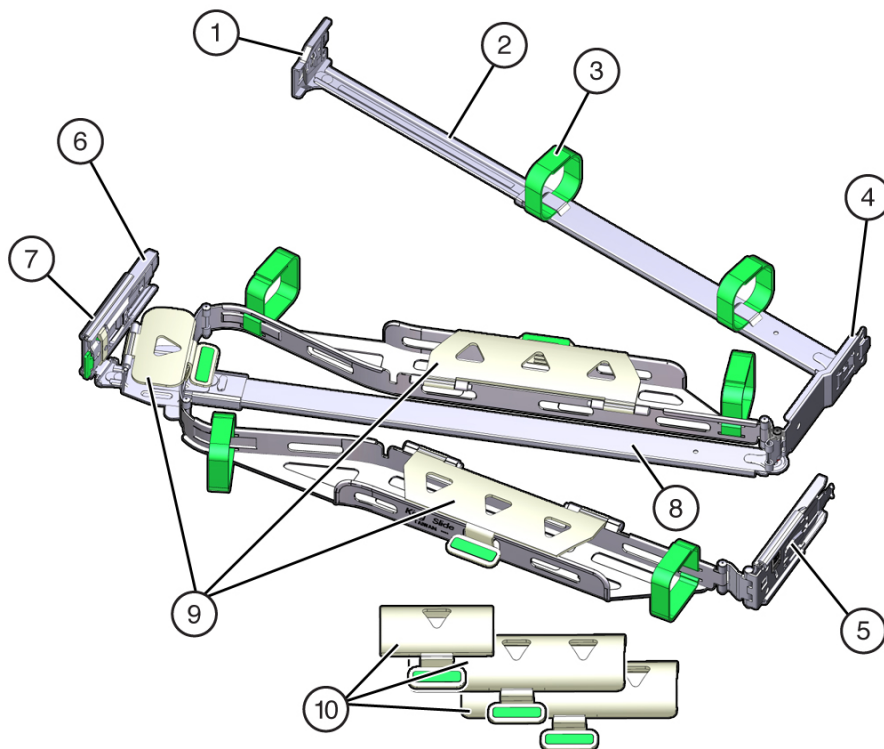

Call Out	Description
1	Connector A
2	Front slide bar
3	Velcro straps (6)
4	Connector B
5	Connector C
6	Connector D
7	Slide-rail latching bracket (used with connector D)
8	Back slide bar
9	Server flat cable covers
10	Server round cable covers (optional)

2. Prepare the CMA for installation.
 - a. Ensure that you install the flat cable covers for your server on the CMA.
 - b. Ensure that the six Velcro straps are threaded into the CMA.

 **Note:**

Ensure that the two Velcro straps located on the front slide bar are threaded through the opening in the top of the slide bar, as shown in the illustration in Step 1. This prevents the Velcro straps from interfering with the expansion and contraction of the slide bar when the server is extended out of the rack and returned to the rack.

- c. To make it easier to install the CMA, extend the server approximately 13 cm (5 inches) out of the front of the rack.
- d. Take the CMA to the back of the equipment rack, and ensure that you have adequate room to work at the back of the server.

 **Note:**

References to "left" or "right" in this procedure assume that you are facing the back of the equipment rack.

 **Note:**

Throughout this installation procedure, support the CMA and do not allow it to hang under its own weight until it is secured at all four attachment points.

- 3. To install CMA connector A into the left slide-rail:
 - a. Insert CMA connector A into the front slot on the left slide-rail until it locks into place with an audible click [1 and 2].
The connector A tab (callout 1) goes into the slide-rail front slot (callout 2).
 - b. Gently tug on the left side of the front slide bar to verify that connector A is properly seated.

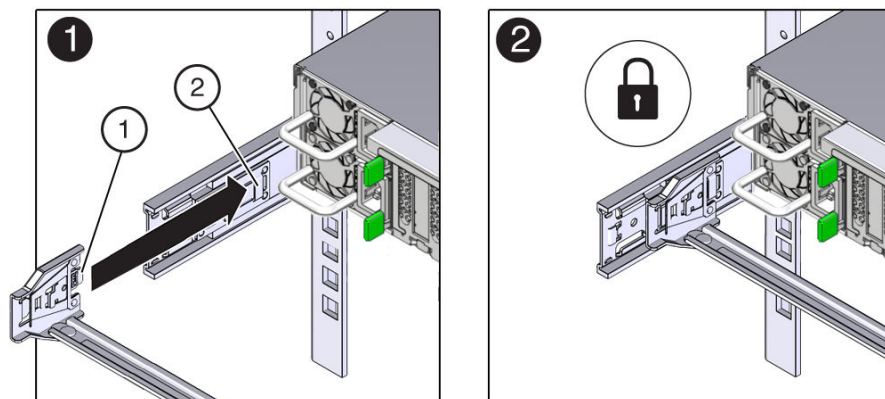

Call Out	Description
1	Connector A tab
2	Left slide-rail front slot

4. To install CMA connector B into the right slide-rail:
 - a. Insert CMA connector B into the front slot on the right slide-rail until it locks into place with an audible click [1 and 2].
The connector B tab (callout 1) goes into the slide-rail front slot (callout 2).
 - b. Gently tug on the right side of the front slide bar to verify that connector B is properly seated.

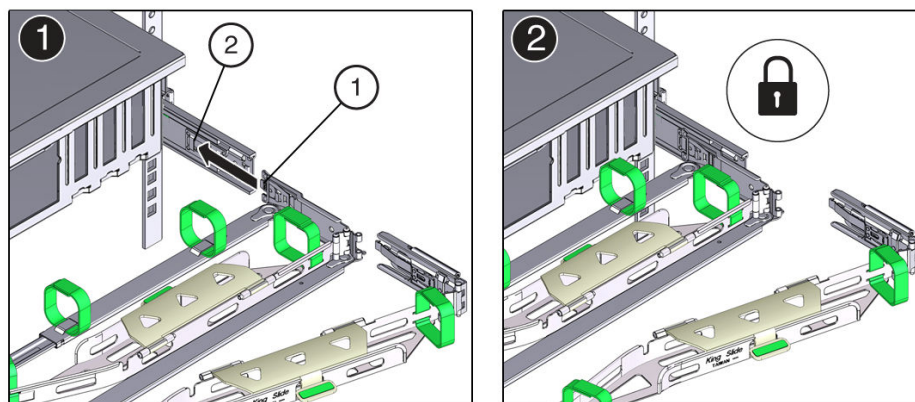

Call Out	Description
1	Connector B tab
2	Right slide-rail front slot

5. To install CMA connector C into the right slide-rail:
 - a. Align connector C with the slide-rail so that the locking spring (callout 1) is positioned inside (server side) of the right slide-rail [1].

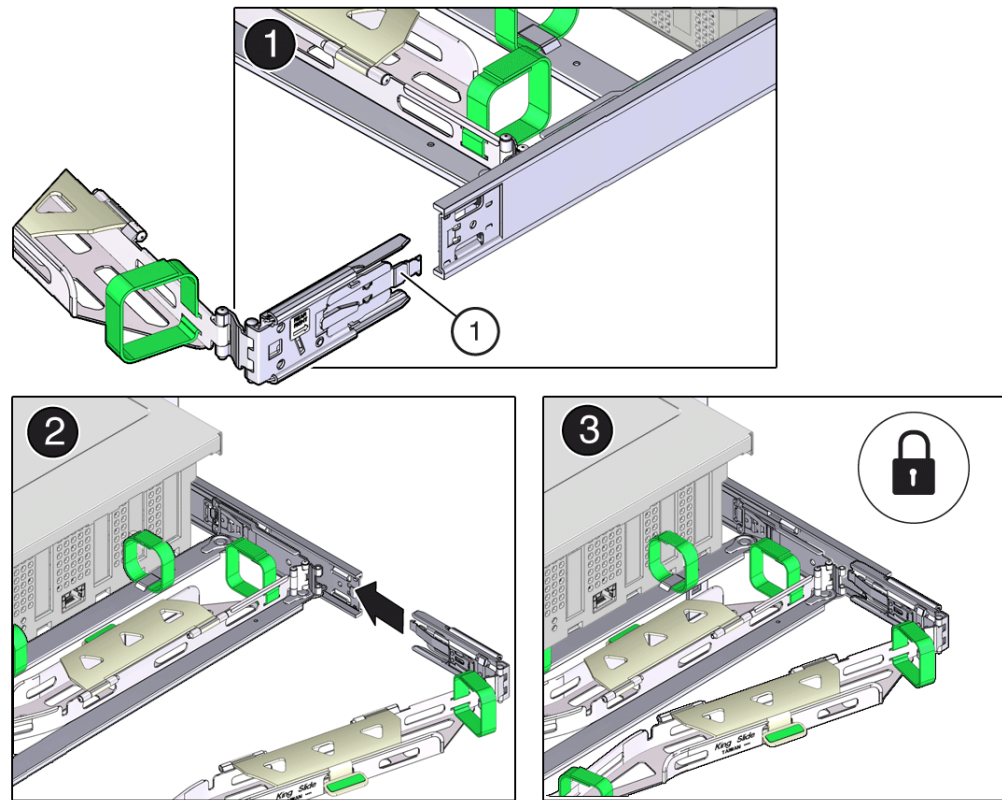

Call Out	Description
1	Connector C locking spring

- b. Insert connector C into the right slide-rail until it locks into place with an audible click [2 and 3].
 - c. Gently tug on the right side of the CMA back slide bar to verify that connector C is properly seated.
6. To prepare CMA connector D for installation, remove the tape that secures the slide-rail latching bracket to connector D, and ensure that the latching bracket is properly aligned with connector D [1 and 2].

 **Note:**

The CMA is shipped with the slide-rail latching bracket taped to connector D. You must remove the tape before you install this connector.

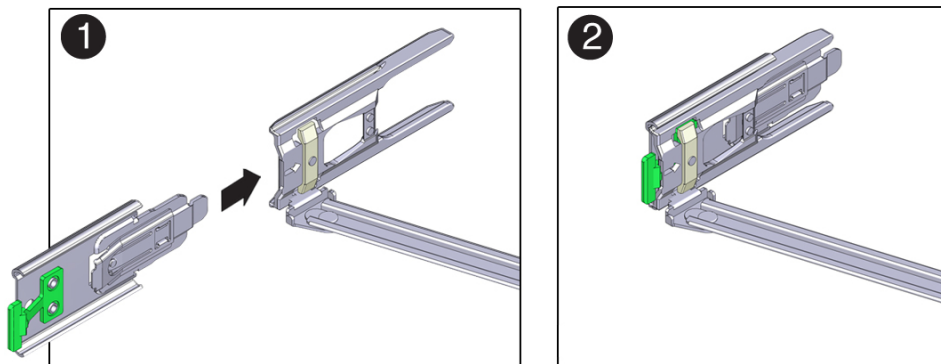

7. To install CMA connector D into the left slide-rail:
 - a. While holding the slide-rail latching bracket in place, insert connector D and its associated slide-rail latching bracket into the left slide-rail until connector D locks into place with an audible click [1 and 2].

 **Note:**

When inserting connector D into the slide-rail, the preferred and easier method is to install connector D and the latching bracket as one assembly into the slide-rail.

- b. Gently tug on the left side of the CMA back slide bar to verify that connector D is properly seated.

 **Note:**

The slide-rail latching bracket has a green release tab. Use the tab to release and remove the latching bracket so that you can remove connector D.

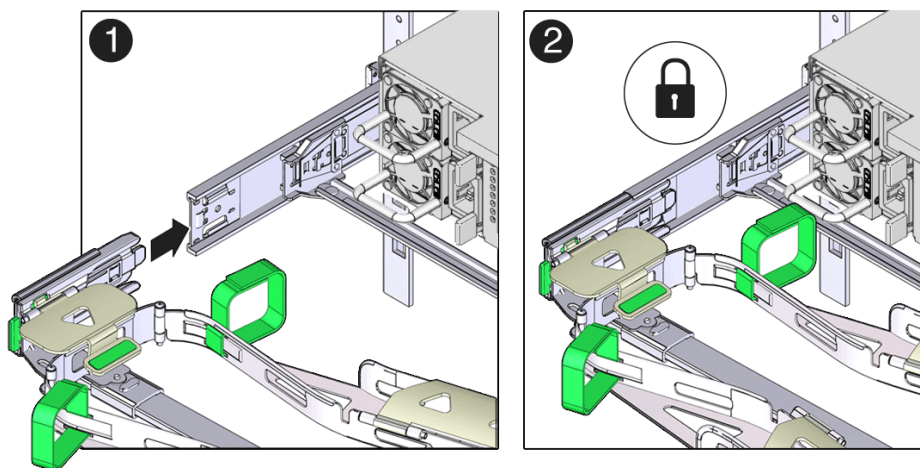

8. Gently tug on the four CMA connection points to ensure that the CMA connectors are fully seated before you allow the CMA to hang by its own weight.
9. To verify that the slide-rails and the CMA are operating properly before routing cables through the CMA:
 - a. Ensure that the rack anti-tilt bar is extended to prevent the rack from tipping forward when the server is extended.

▲ Caution:

To reduce the risk of personal injury, stabilize the rack cabinet and extend the anti-tilt bar before extending the server from the rack.

- b. Slowly pull the server out of the rack until the slide-rails reach their stops.
- c. Inspect the attached cables for any binding or kinks.
- d. Verify that the CMA extends fully with the slide-rails.

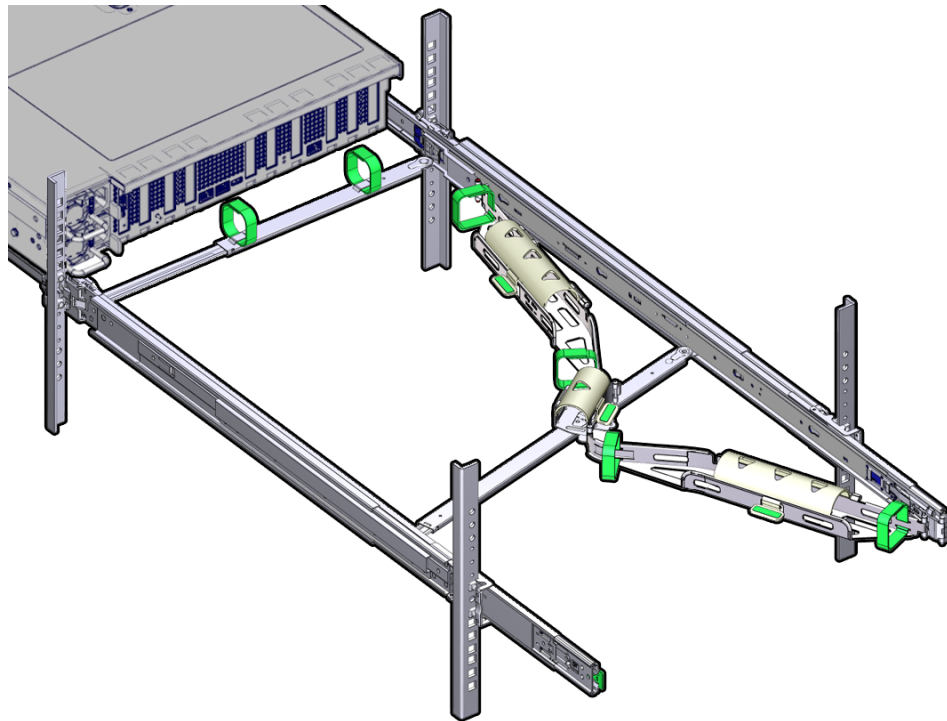

10. To return the server to the rack:
 - a. Simultaneously pull and hold the two green release tabs (one on each side of the server) toward the front of the server while you push the server into the rack. As you push the server into the rack, verify that the CMA retracts without binding.
 - b. To pull the green release tabs, place your finger in the center of each tab, not on the end, and apply pressure as you pull the tab toward the front of the server.

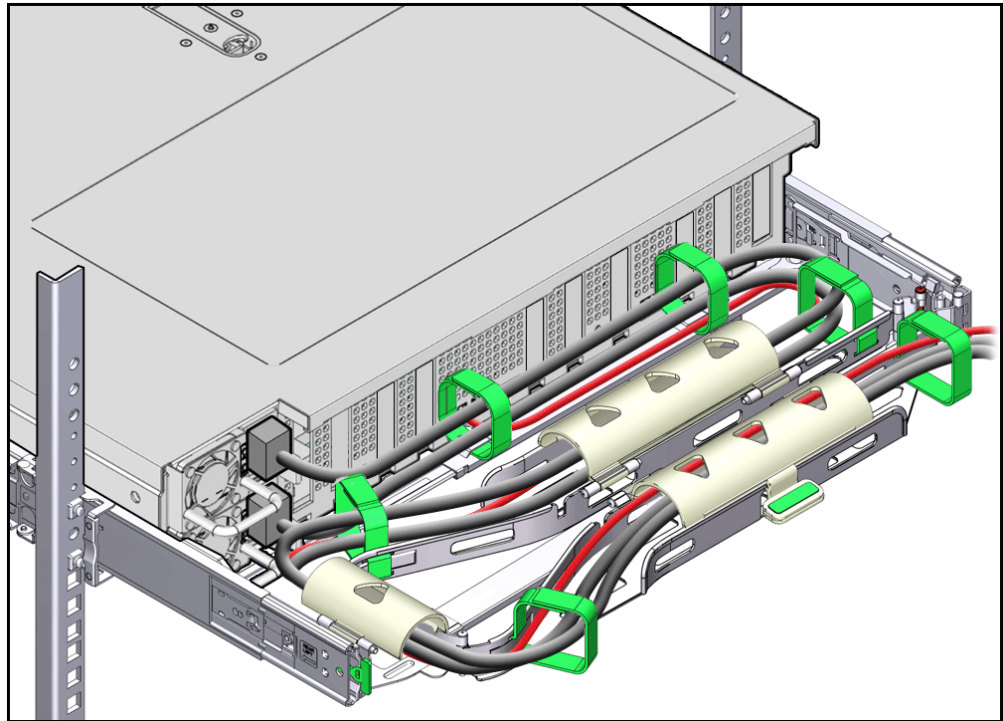

13. Ensure that the secured cables do not extend above the top or below the bottom of the server to which they are attached.

Otherwise, the cables might snag on other equipment installed in the rack when the server is extended from the rack or returned to the rack.

14. If necessary, bundle the cables with additional Velcro straps to ensure that they stay clear of other equipment.

 **Note:**

If you need to install additional Velcro straps, wrap the straps around the cables only, not around any of the CMA components. Otherwise, expansion and contraction of the CMA slide bars might be hindered when the server is extended from the rack and returned to the rack.

Installing Oracle Database Appliance X10-HA Into a Rack

Procedures describing how to install Oracle Database Appliance X10-HA into a rack.

 **Caution:**

System Failure. Oracle Database Appliance is shipped with matched sets of components that must be installed together. Mixing components from different systems might cause the system to fail.

- [Contents of the Shipping Container](#)
A listing of the ship container contents of Oracle Database Appliance X10-HA.
- [Installation Sequence](#)
Understand the proper installation sequence when installing an Oracle Database Appliance X10-HA into a rack.
- [Verify Component Compatibility](#)
Ensure that appliance components bundled together from the factory are connected together.
- [Tools and Equipment Needed](#)
A listing of the tools you will need to install Oracle Database Appliance X10-HA.
- [Stabilize the Rack for Installation](#)
- [Apply Labels to Server Nodes](#)
Complete this task to apply server node labels before installing the appliance into a rack.
- [Install the Storage Shelf Into a Rack](#)
Describes how to install an Oracle Database Appliance X10-HA storage shelf into a rack.
- [Add a Storage Expansion Shelf to an Existing System](#)
Use this procedure to add a storage expansion shelf to an appliance system that is already running.
- [Rackmount Kit Contents](#)
- [Install Mounting Brackets on the Server](#)
- [Mark the Rackmount Location](#)
- [Attach the AC Power Cables and Server Slide-Rails to the Rack](#)
- [Install the Server Into the Slide-Rail Assemblies](#)
- [Install the Cable Management Arm \(Optional\)](#)

Contents of the Shipping Container

A listing of the ship container contents of Oracle Database Appliance X10-HA.

For Oracle Database Appliance X10-HA, server nodes are shipped on a single pallet, and the storage shelf and storage expansion shelf are shipped separately. Each component include mounting hardware, cables, and labels.

Caution:

System failure. All items in a shipment are designed to be used together as a single system. Do not mix components from different shipments; this could cause the system to fail. For details, see [Verify Component Compatibility](#).

The items required for your appliance include:

- Server node 0 and server node 1 (shipped together)
- Rackmounting hardware, cables, and labels for server nodes 0 and 1

Tools and Equipment Needed

A listing of the tools you will need to install Oracle Database Appliance X10-HA.

Obtain the following tools and equipment before beginning the installation of Oracle Database Appliance X10-HA.

- Phillips head No. 2 screwdriver that is a minimum of 4 inches long
- T20 Torx driver if using a threaded rack
- A mechanical lift is highly recommended

Caution:

Personal injury or equipment damage. The storage shelf weighs approximately 51 lbs (23 kg). If no mechanical lift is available, use three people to place it in the rack.

Stabilize the Rack for Installation

Caution:

Personal injury or equipment damage. To reduce the risk of personal injury, stabilize the rack cabinet, and extend all anti-tilt devices before installing the server.

Refer to your rack cabinet documentation for more detailed instructions.

1. When unpacking at the installation site, verify that the rack cabinet leveling feet are up before moving the rack cabinet.
2. Remove the front and rear doors of the rack cabinet if they interfere with the installation.
3. To prevent the rack cabinet from tipping during the installation, fully extend the rack cabinet's anti-tilt legs or anti-tilt bar, which are located at the bottom front of the rack cabinet.
4. If there are leveling feet beneath the rack cabinet to prevent it from rolling, extend these leveling feet fully downward to the floor once the rack cabinet is where it will reside in the data center.
5. When moving a rack cabinet to a different location, including repacking, verify that rack cabinet leveling feet are up before moving the rack cabinet.

Apply Labels to Server Nodes

Complete this task to apply server node labels before installing the appliance into a rack.

1. Find the labels.

The shipping kit includes server node labels. The storage shelf labels are applied at the factory.

2. Verify that the locations where the labels need to go are clean, and free of grease and dirt.
3. Apply the labels where needed:

For labels that you attach, peel off the backing sheet and apply the label to the corresponding spot on the right-hand side of the appliance front panel.

- Server Node 1: Apply this label to the top server node [1].
- Server Node 0: Apply this label to the lower server node [2].

The following figure shows the locations where labels should be applied:

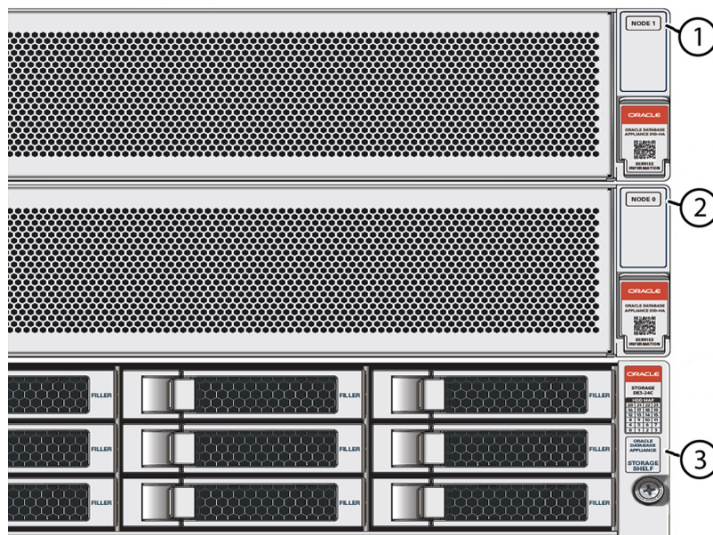

Callout	Description
1	Server node 1
2	Server node 0
3	Storage shelf

Install the Storage Shelf Into a Rack

Describes how to install an Oracle Database Appliance X10-HA storage shelf into a rack.

The Oracle Database Appliance X10-HA uses the Oracle Storage Drive Enclosure DE3-24C as its storage shelf. The storage shelf requires four standard mounting units (4RU) of vertical space in the cabinet.

- Ensure that your site meets the requirements in [Oracle Database Appliance Specifications](#)
- Ensure that the rack meets the requirements in [Rack Compatibility Requirements](#)

 **Note:**

The rail kit included with the shelf can only be used with EIA compliant 9.5 mm square hole racks or 7.0 mm diameter round hole racks.

- Observe all precautions in [Safety Precautions When Rackmounting](#)
- 1. Starting at the bottom of the cabinet, locate the appropriate rack unit (RU) height.
Storage shelves must be installed below the server nodes to prevent the rack from tipping.
- 2. Open the storage shelf rail kit box and find the cage nut packets included with the kit, and confirm if your rack uses square or round holes.

The cage nut packets include a special template for either round or square hole racks for positioning the cage nuts.

 **Note:**

The following steps show rail kit installation with a square hole rack. The same steps would apply for a round hole rack.

The following figure shows the rack rail installation kit contents:

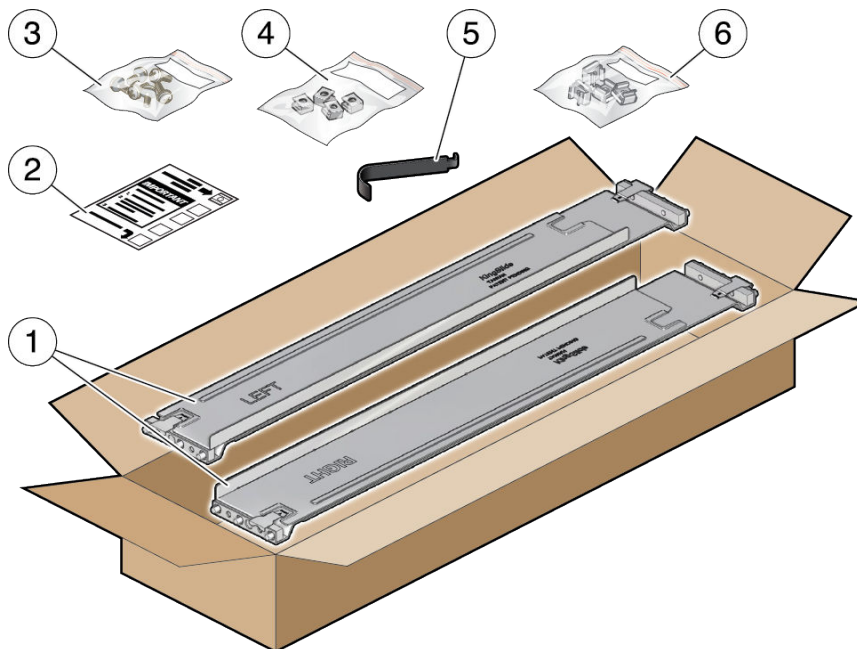

Callout	Description
1	Two adjustable storage shelf rails
2	Cage nut installation template

Callout	Description
3	Six rear 10-32 7mm shipping screws (2 are spares)
4	Four round 7mm 10-32 cage nuts per set (2 are spares). Only one set is required, either square or round.
5	Cage nut tool
6	Four square 9.5mm 10-32 cage nuts per set (2 are spares). Only one set is required, either square or round.

3. Attach the storage shelf rails to the rack, as follows:
 - a. Orient the rail so that the stamped label (LEFT or RIGHT) is facing the inside of the rack.
 - b. Adjust the rail length to fit the front and rear of the rack.

 **Note:**

Mark which rack rail holes you will be using to ensure the storage shelf rails are installed evenly and correctly the first time.

- c. Hold open the rail clamp at each end of the rail by pressing the clamp lever [1] and insert both ends of the rail into the appropriate rack holes [2].

The following figure shows how to fit the storage shelf rails to the rack:

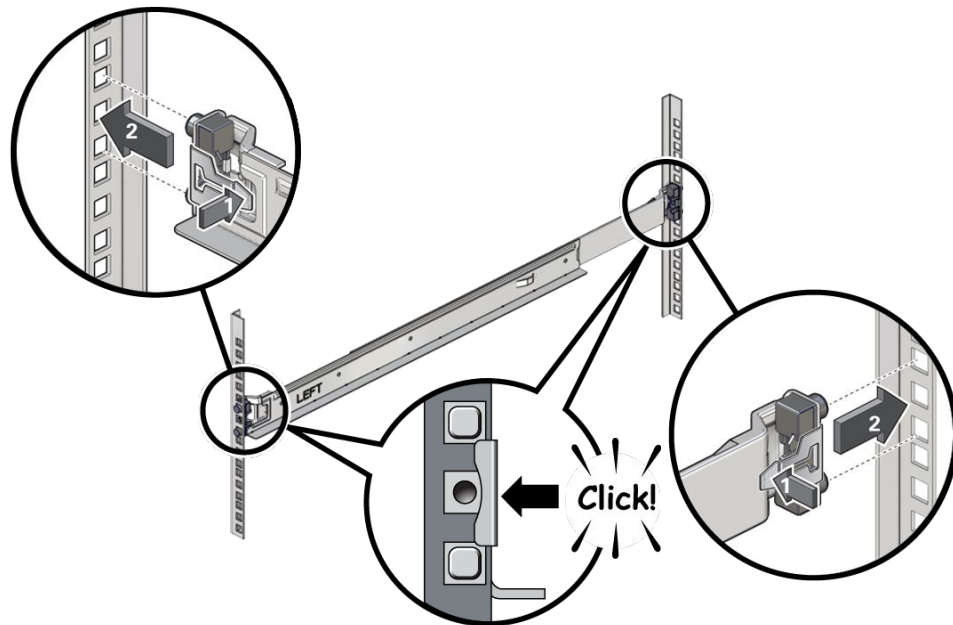

- d. Close the rail clamps over the rails by releasing the clamp lever.
You will hear an audible click as the clamps lock in place over the rack rails.
- e. Repeat steps 3a through 3d for the second rail.

4. Install one screw through the rack and into the rear of each rail.

The following figure shows how to secure the storage shelf rails to the rack:

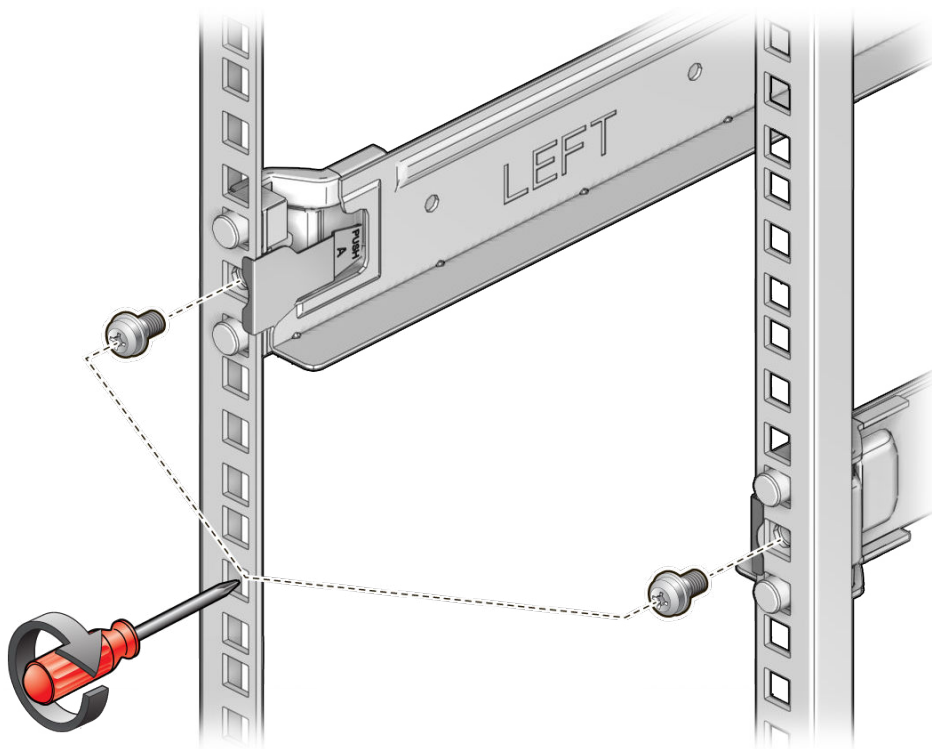

5. Install the front cage nuts.

▲ Caution:

Installing the storage shelf without the front cage nuts will cause the storage shelf to be unstable. You would then need to remove the storage shelf from the rack to install the cage nuts.

The following figure shows how to install the front cage nuts in the rack:

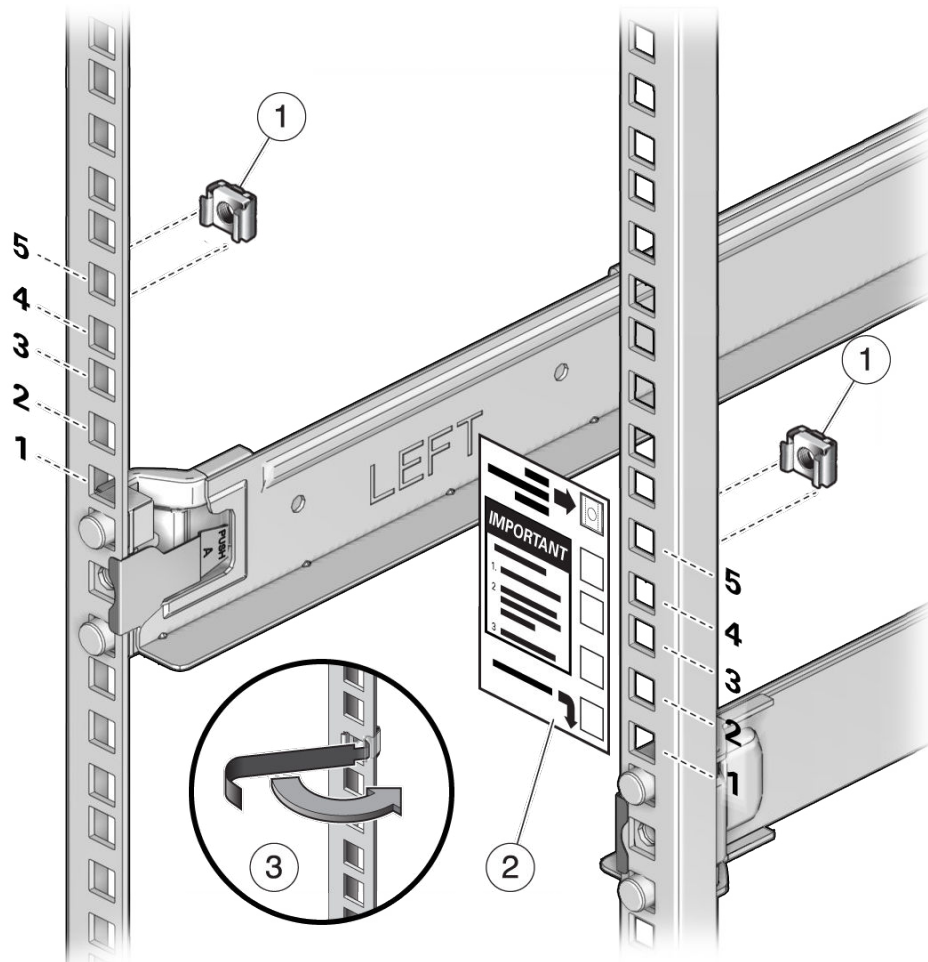

Callout	Description
1	Cage nuts
2	Cage nut installation template
3	Cage nut tool

- a. Use the template [2] to determine cage nut placement.
 - b. Retrieve a cage nut and hook one lip of the nut into the appropriate rail hole [1].
 - c. Insert the tip of the cage nut insertion tool through the rail hole [3] and hook the other lip of the cage nut. Pull the cage nut through the hole until the lip snaps into place.
 - d. Repeat through steps 5a through 5c for the second cage nut.
6. Using a mechanical lift or three people, one at each side of the storage shelf and one in front, carefully lift and rest the shelf on the bottom ledge of the left and right rails. Do not lift using the power supply handles.

The following figure shows how to install the storage shelf into the rack:

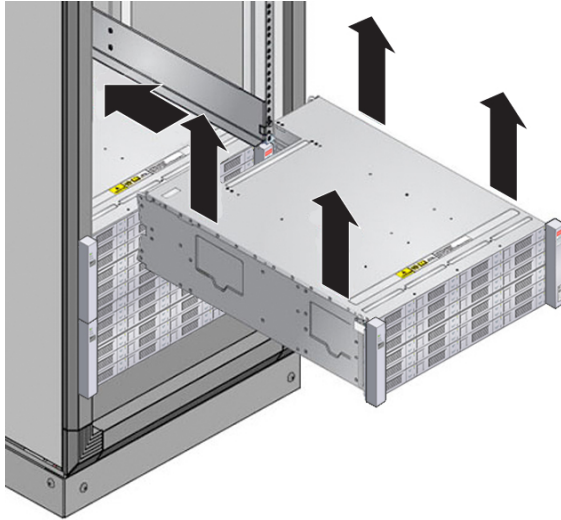

7. Carefully slide the shelf into the cabinet. Ensure that the shelf is fully seated within the rails. If removing the shelf to reseal it, support it at all times.
8. Secure the front of the shelf using the four captive securing screws [1 - 4].

The following figure shows how to secure the front of the storage shelf:

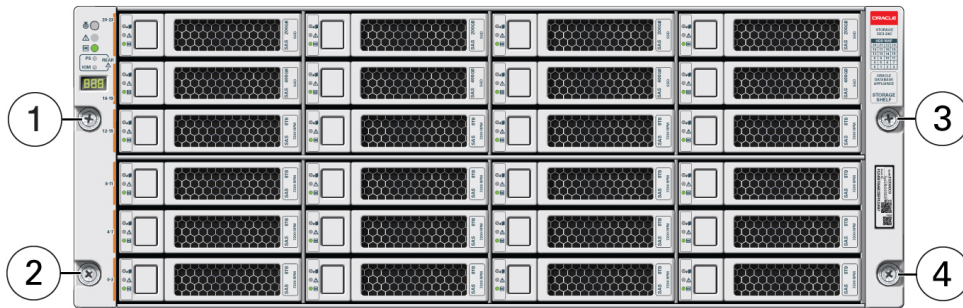

9. To secure the storage shelf in the rack for shipping, install a screw in each rear storage shelf chassis ear.

The following figure shows how to secure the storage shelf rear shipping ears:

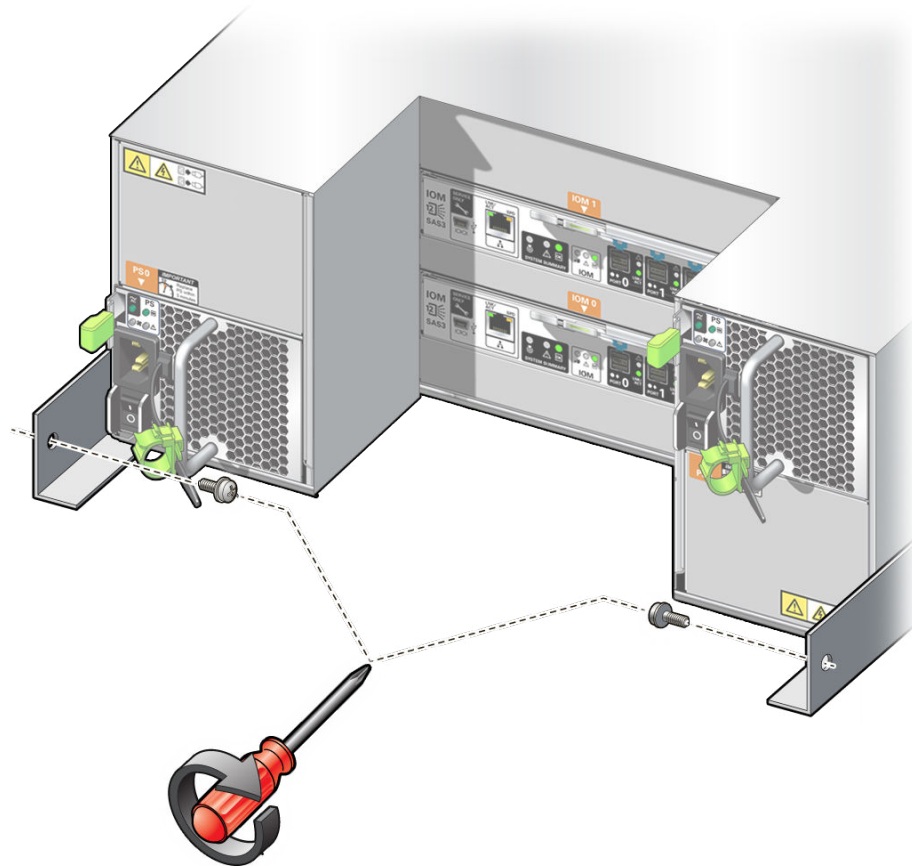

10. Attach AC power cords to the storage shelf power supplies and to the rack PDUs (Power Distribution Units).

 **Note:**

Splitting AC power cords between the left and right rack PDUs allows for devices that have redundant power supplies to plug the primary power supply into one PDU and the secondary (redundant) power supply into a different PDU, increasing redundancy.

11. Repeat these steps if you have an additional storage shelf to install.

Add a Storage Expansion Shelf to an Existing System

Use this procedure to add a storage expansion shelf to an appliance system that is already running.

This task assumes that you are adding a storage expansion shelf to an already running Oracle Database Appliance (must already have a fully populated storage shelf).

Unless noted, it is not necessary to shut down your system to complete this task.

Please note the following exceptional conditions:

- The storage expansion shelf normally sits at the bottom of Oracle Database Appliance, beneath the storage shelf. However, since racks should always be provisioned from the

bottom up, that space might be unavailable. In these cases, to avoid re-rackmounting the entire system, it can be placed above the server nodes, or even in a different rack.

- The Top Level Identifier (TLI) on the storage expansion shelf will not match the rest of the system as described in [Verify Component Compatibility](#). However, adding a storage expansion shelf after your initial purchase and setup of the appliance is a supported configuration.
1. Install the storage expansion shelf as described in [Install the Storage Shelf Into a Rack](#).
 2. Cable, power-on, and verify that the new storage is added.

Refer to the appropriate *Deployment and User's Guide* for additional information.

Rackmount Kit Contents

The following figure shows the Rackmount Kit contents. For additional instructions on how to install your server in a four-post rack using the slide-rail and cable management arm options, refer to the Rackmounting Template.

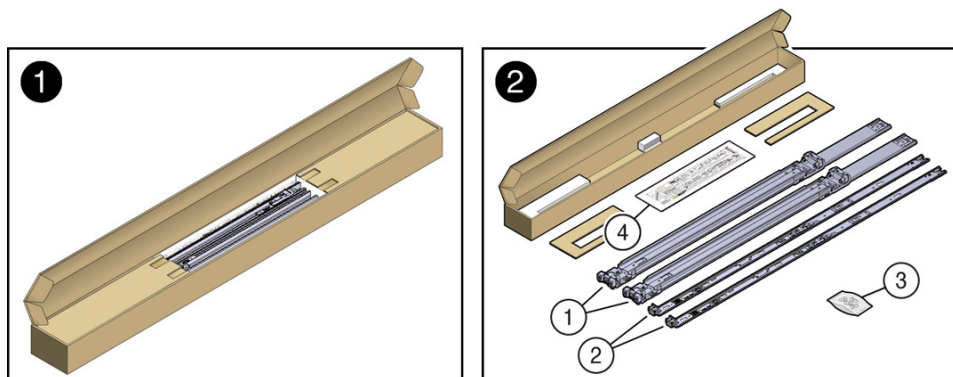

Call Out	Description
1	Slide-rails
2	Mounting brackets
3	Four M4 x 5 fine-pitch mounting bracket securing screws (optional)
4	Rackmounting Template

Install Mounting Brackets on the Server

To install the mounting brackets on the sides of the server:

1. Position a mounting bracket against the chassis so that the slide-rail lock is at the server front, and the five keyhole openings on the mounting bracket are aligned with the five locating pins on the side of the chassis.

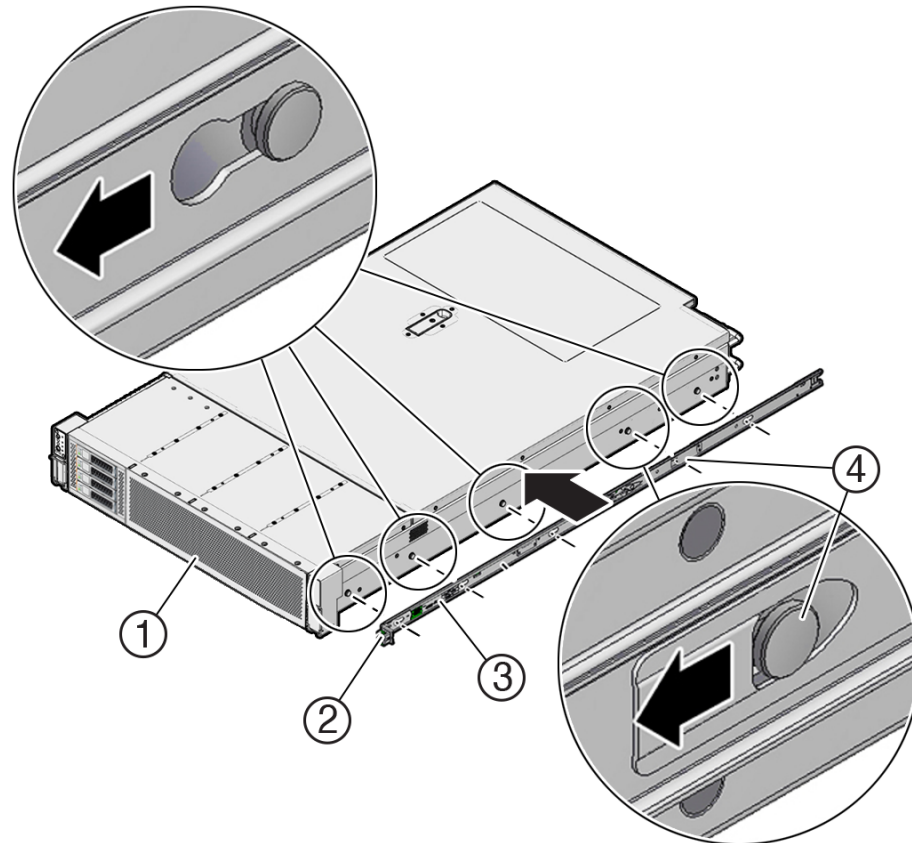

Call Out	Description
1	Chassis front
2	Slide-rail lock
3	Mounting bracket
4	Mounting bracket clip

2. When the heads of the five chassis locating pins protrude through the five keyhole openings in the mounting bracket, pull the mounting bracket toward the front of the chassis until the mounting bracket clip locks into place with an audible click.
3. Verify that the back locating pin is engaged with the mounting bracket clip.
4. Repeat Step 1 through Step 3 to install the other mounting bracket on the other side of the server.

Mark the Rackmount Location

Identify the location in the rack where you want to place the server. Oracle Database Appliance server requires two rack units (2U). Use the Rackmounting Template to identify the correct mounting holes for the slide-rails.

▲ Caution:

Always load equipment into a rack from the bottom up so that the rack does not become top-heavy and tip over. Extend the rack anti-tilt bar to prevent the rack from tipping during equipment installation.

1. Ensure that there is at least two rack units (2U) of vertical space in the rack cabinet to install the server. See [Rack Compatibility](#).
2. Place the Rackmounting Template against the front rails, and measure up from the bottom of the Rackmounting Template. The bottom edge of the Rackmounting Template card corresponds to the bottom edge of the server.

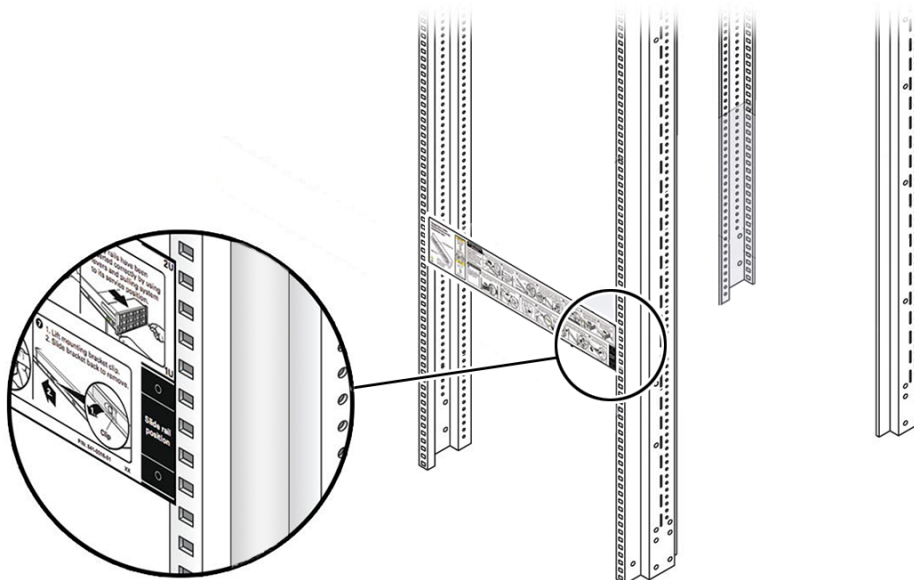

3. Mark the mounting holes for the front slide-rails.

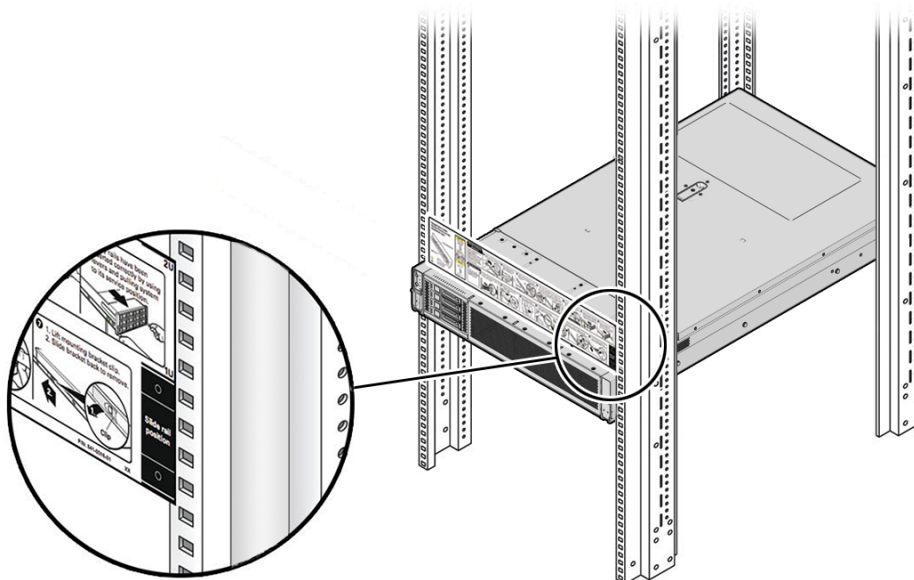

4. Mark the mounting holes for the back slide-rails.

Attach the AC Power Cables and Server Slide-Rails to the Rack

Use this procedure to attach the server slide-rail assemblies to the rack.

Note:

Be sure to install the server right-angle AC power cables that came with your system. In some racks, the standard rail kit slide-rails obstructs access to the front of the Power Distribution Unit (PDU) electrical sockets. Plug in your AC power cables into the PDU first, and then install the slide-rails into the rack. After you install the slide-rails, you cannot disconnect or remove the standard AC power cables from the PDU, but you can remove them from the system power supply.

1. Before you install the server slide-rails into the rack, install the right-angle end of the AC power cables that came with the system into the left-side and right-side rack PDU electrical sockets.

Note:

Splitting AC power cords between the left and right rack PDUs allows for devices that have redundant power supplies to plug the primary power supply into one PDU and the secondary (redundant) power supply into a different PDU, increasing redundancy.

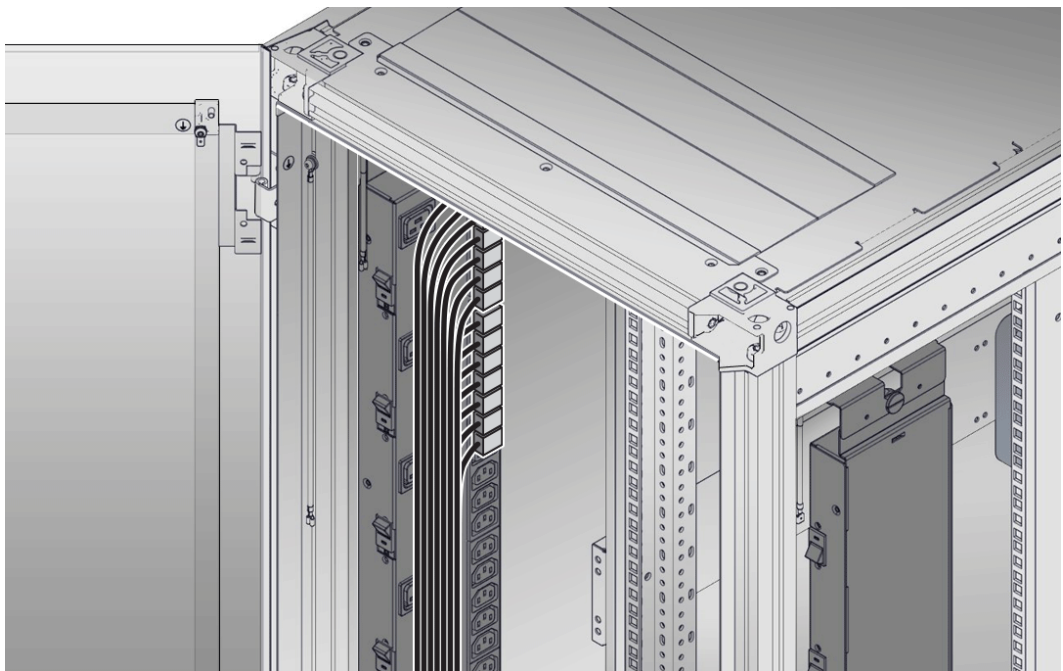

2. Orient the system slide-rail assembly so that the ball-bearing track is forward and locked in place.

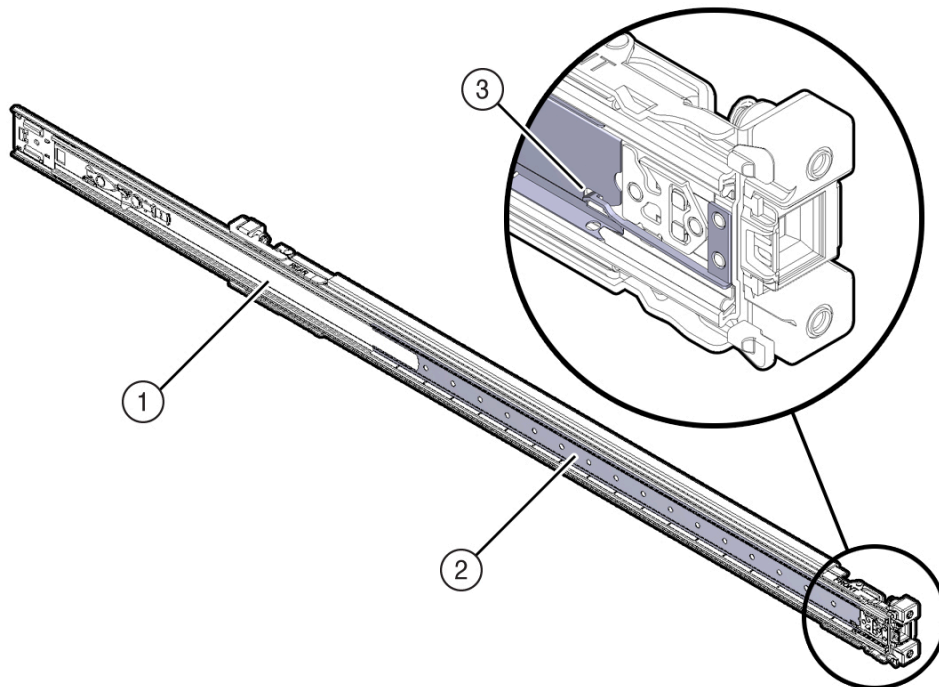

Call Out	Description
1	Slide-rail
2	Ball-bearing track
3	Ball-bearing locking mechanism

3. Starting with either the left or right side of the rack, align the back of the slide-rail assembly against the inside of the back rack rail, and push until the assembly locks into place with an audible click.

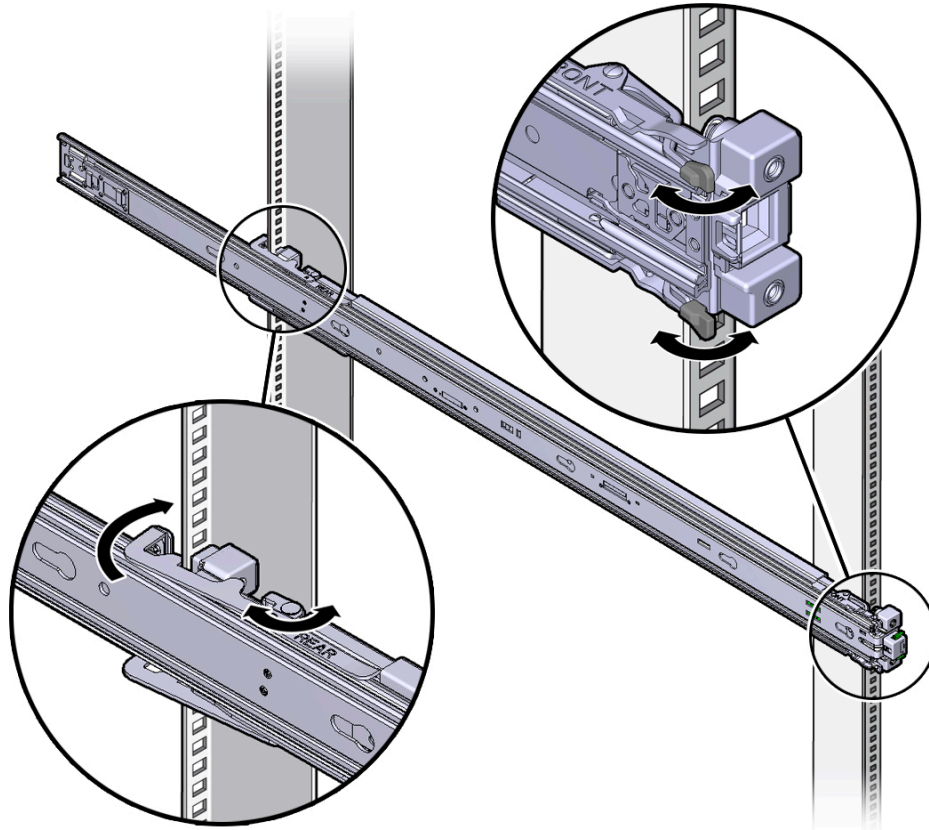

4. Align the front of the slide-rail assembly against the outside of the front rack rail, and push until the assembly locks into place with an audible click.
5. Repeat Step 2 through Step 4 to attach the slide-rail assembly to the other side of the rack.

Install the Server Into the Slide-Rail Assemblies

Use this procedure to install the server chassis with mounting brackets into the slide-rail assemblies that are mounted to the rack.

▲ Caution:

Personal Injury or Equipment Damage: This procedure requires a minimum of two people because of the weight of the server. Attempting this procedure alone could result in equipment damage or personal injury.

Always load equipment into a rack from the bottom up so that the rack does not become top-heavy and tip over. Extend the rack anti-tilt bar to prevent the rack from tipping during equipment installation.

1. If you haven't already done so, fully extend the rack cabinet's anti-tilt bar located at the bottom front of the rack cabinet.
2. Push the slide-rails as far as possible into the slide-rail assemblies in the rack.

3. Position the server so that the back ends of the mounting brackets are aligned with the slide-rail assemblies that are mounted in the rack.
4. Insert the mounting brackets into the slide-rails, and then push the server into the rack until the mounting brackets are flush with the slide-rail stops (approximately 30 cm or 12 inches).

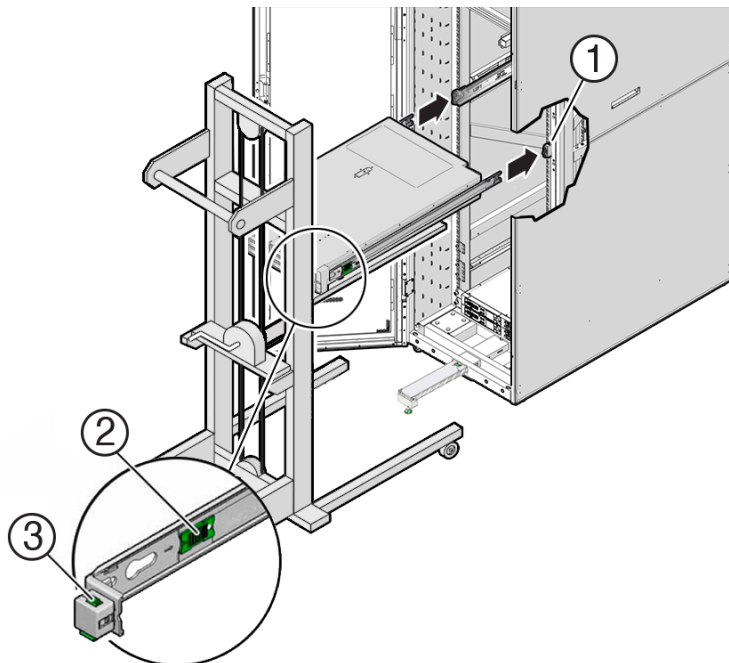

Call Out	Description
----------	-------------

- | | |
|---|--|
| 1 | Inserting mounting bracket into slide-rail |
| 2 | Slide-rail release button |
| 3 | Slide-rail lock |
-

5. Simultaneously push and hold the green slide-rail release buttons on each mounting bracket while you push the server into the rack. Continue pushing the server into the rack until the slide-rail locks (on the front of the mounting brackets) engage the slide-rail assemblies with an audible click.

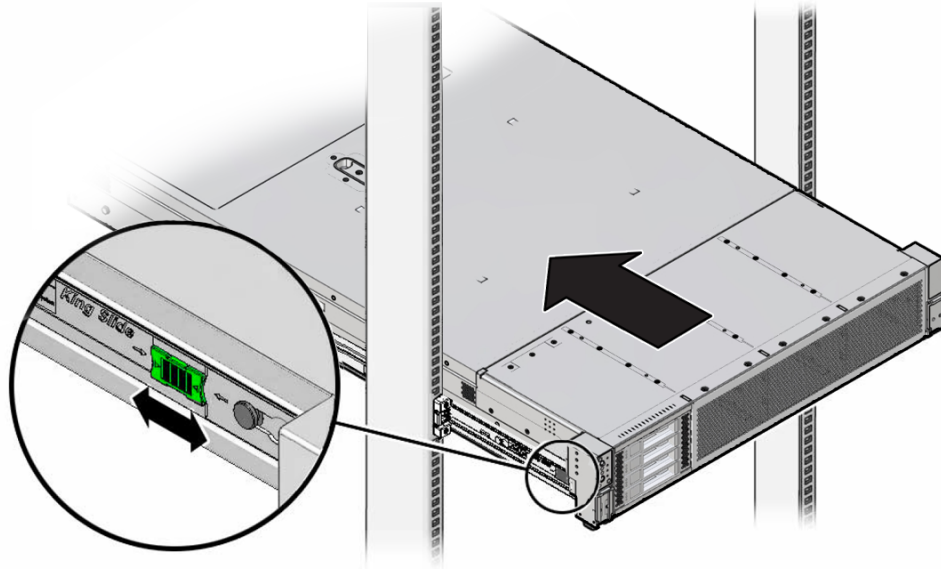

▲ Caution:

Before you install the optional cable management arm verify that the server is securely mounted in the rack and that the slide-rail locks are engaged with the mounting brackets.

6. Do one of the following:
 - If you purchased the optional cable management arm, proceed to the next section.
 - If you did not purchase the optional cable management arm, retract the rack anti-tilt mechanism back to its normal position and plug in AC power to the system.

Install the Cable Management Arm (Optional)

Follow this procedure to install the cable management arm (CMA), which you can use to manage cables connected to the back of the server.

✎ Note:

Before you install the CMA, ensure that the right-angle AC power cables are long enough to connect to the rackmounted servers when routed through the CMA.

1. Unpack the CMA, which contains the following components.

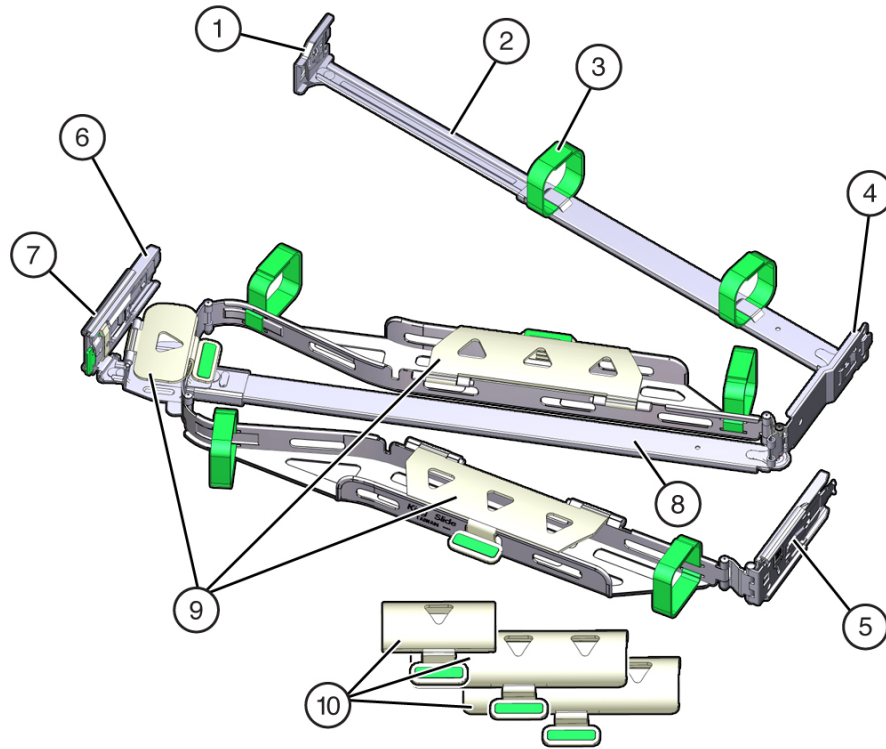

Call Out	Description
1	Connector A
2	Front slide bar
3	Velcro straps (6)
4	Connector B
5	Connector C
6	Connector D
7	Slide-rail latching bracket (used with connector D)
8	Back slide bar
9	Server flat cable covers
10	Server round cable covers (optional)

2. Prepare the CMA for installation.
 - a. Ensure that you install the flat cable covers for your server on the CMA.
 - b. Ensure that the six Velcro straps are threaded into the CMA.

 **Note:**

Ensure that the two Velcro straps located on the front slide bar are threaded through the opening in the top of the slide bar, as shown in the illustration in Step 1. This prevents the Velcro straps from interfering with the expansion and contraction of the slide bar when the server is extended out of the rack and returned to the rack.

- c. To make it easier to install the CMA, extend the server approximately 13 cm (5 inches) out of the front of the rack.
- d. Take the CMA to the back of the equipment rack, and ensure that you have adequate room to work at the back of the server.

 **Note:**

References to "left" or "right" in this procedure assume that you are facing the back of the equipment rack.

 **Note:**

Throughout this installation procedure, support the CMA and do not allow it to hang under its own weight until it is secured at all four attachment points.

- 3. To install CMA connector A into the left slide-rail:
 - a. Insert CMA connector A into the front slot on the left slide-rail until it locks into place with an audible click [1 and 2].
The connector A tab (callout 1) goes into the slide-rail front slot (callout 2).
 - b. Gently tug on the left side of the front slide bar to verify that connector A is properly seated.

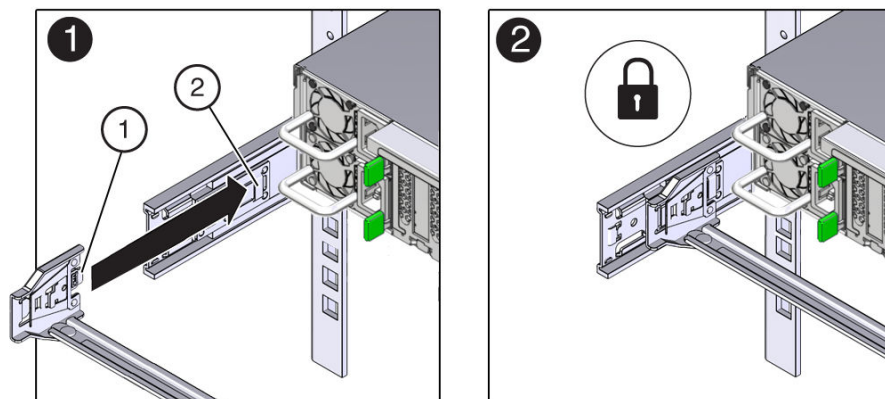

Call Out	Description
1	Connector A tab
2	Left slide-rail front slot

4. To install CMA connector B into the right slide-rail:
 - a. Insert CMA connector B into the front slot on the right slide-rail until it locks into place with an audible click [1 and 2].
The connector B tab (callout 1) goes into the slide-rail front slot (callout 2).
 - b. Gently tug on the right side of the front slide bar to verify that connector B is properly seated.

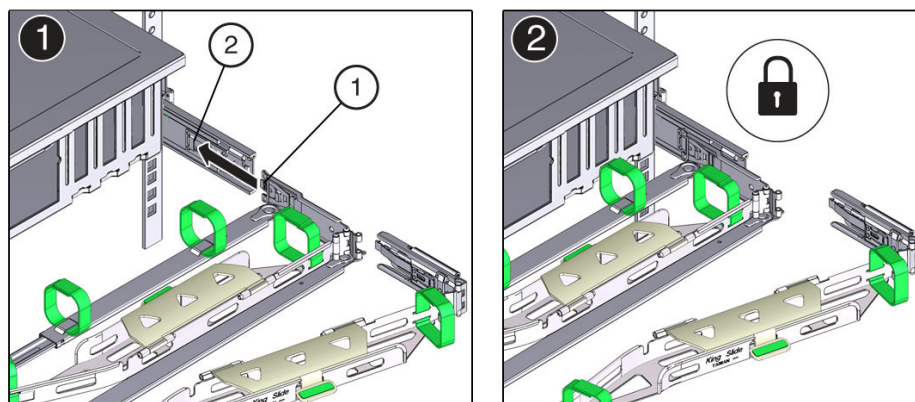

Call Out	Description
1	Connector B tab
2	Right slide-rail front slot

5. To install CMA connector C into the right slide-rail:
 - a. Align connector C with the slide-rail so that the locking spring (callout 1) is positioned inside (server side) of the right slide-rail [1].

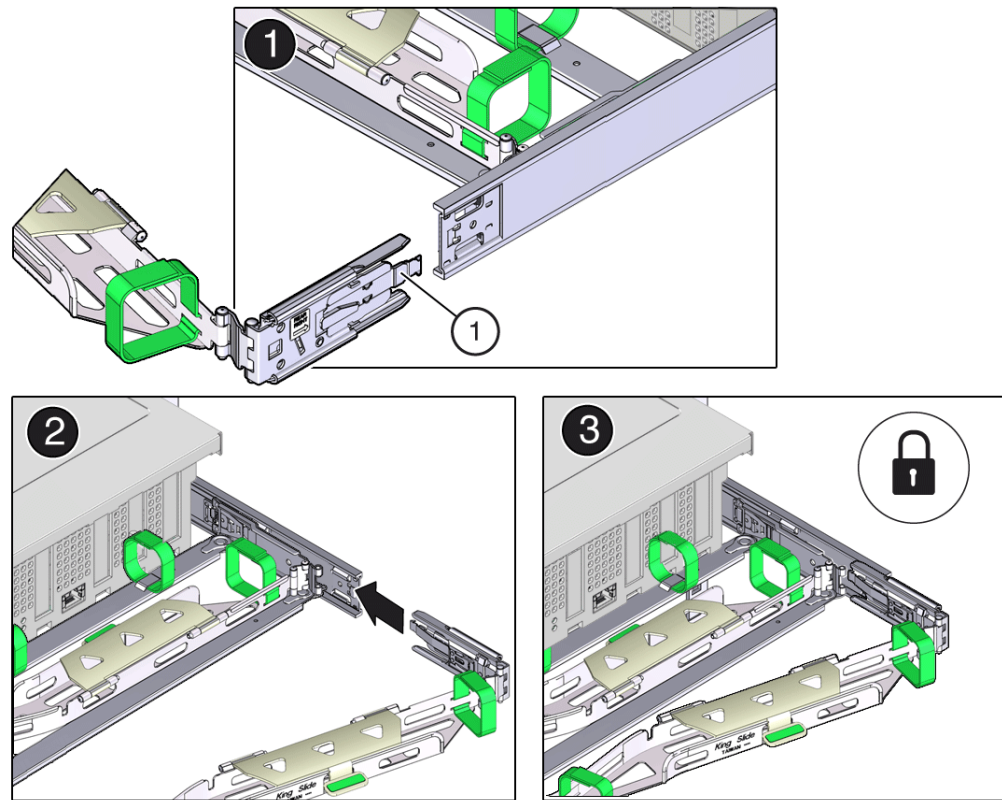

Call Out	Description
1	Connector C locking spring

- b. Insert connector C into the right slide-rail until it locks into place with an audible click [2 and 3].
 - c. Gently tug on the right side of the CMA back slide bar to verify that connector C is properly seated.
6. To prepare CMA connector D for installation, remove the tape that secures the slide-rail latching bracket to connector D, and ensure that the latching bracket is properly aligned with connector D [1 and 2].

 **Note:**

The CMA is shipped with the slide-rail latching bracket taped to connector D. You must remove the tape before you install this connector.

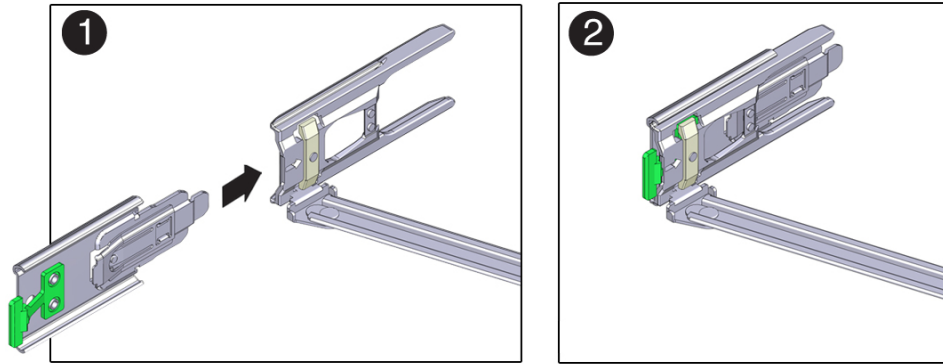

7. To install CMA connector D into the left slide-rail:
 - a. While holding the slide-rail latching bracket in place, insert connector D and its associated slide-rail latching bracket into the left slide-rail until connector D locks into place with an audible click [1 and 2].

 **Note:**

When inserting connector D into the slide-rail, the preferred and easier method is to install connector D and the latching bracket as one assembly into the slide-rail.

- b. Gently tug on the left side of the CMA back slide bar to verify that connector D is properly seated.

 **Note:**

The slide-rail latching bracket has a green release tab. Use the tab to release and remove the latching bracket so that you can remove connector D.

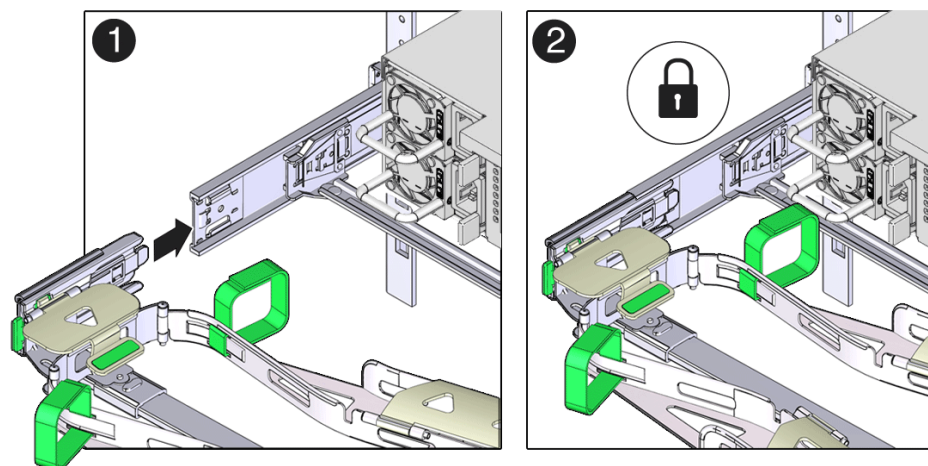

8. Gently tug on the four CMA connection points to ensure that the CMA connectors are fully seated before you allow the CMA to hang by its own weight.
9. To verify that the slide-rails and the CMA are operating properly before routing cables through the CMA:
 - a. Ensure that the rack anti-tilt bar is extended to prevent the rack from tipping forward when the server is extended.

▲ Caution:

To reduce the risk of personal injury, stabilize the rack cabinet and extend the anti-tilt bar before extending the server from the rack.

- b. Slowly pull the server out of the rack until the slide-rails reach their stops.
- c. Inspect the attached cables for any binding or kinks.
- d. Verify that the CMA extends fully with the slide-rails.

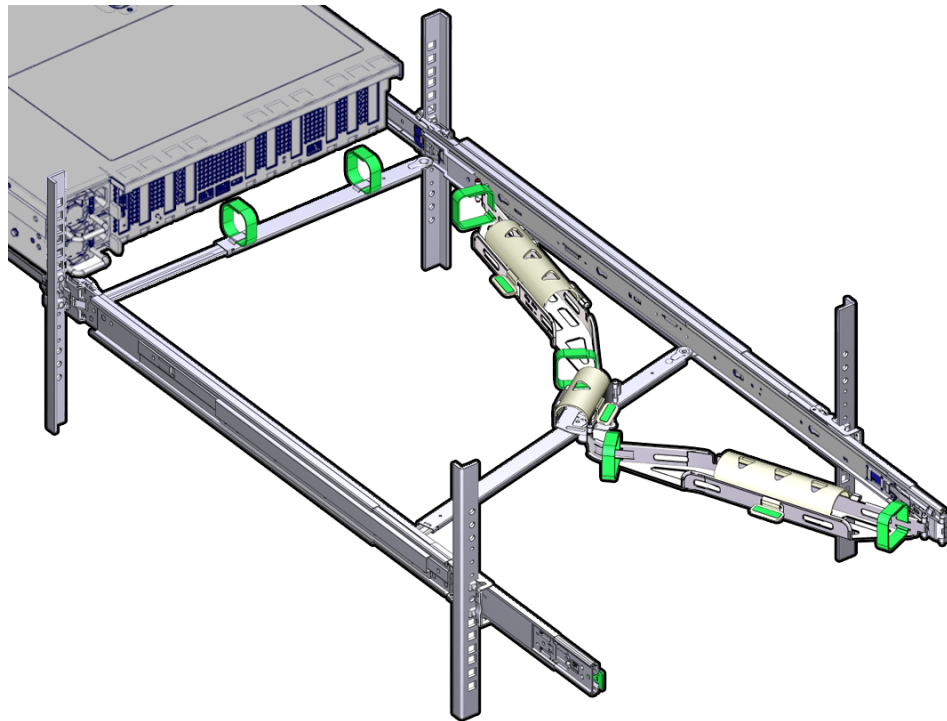

10. To return the server to the rack:
 - a. Simultaneously pull and hold the two green release tabs (one on each side of the server) toward the front of the server while you push the server into the rack. As you push the server into the rack, verify that the CMA retracts without binding.
 - b. To pull the green release tabs, place your finger in the center of each tab, not on the end, and apply pressure as you pull the tab toward the front of the server.

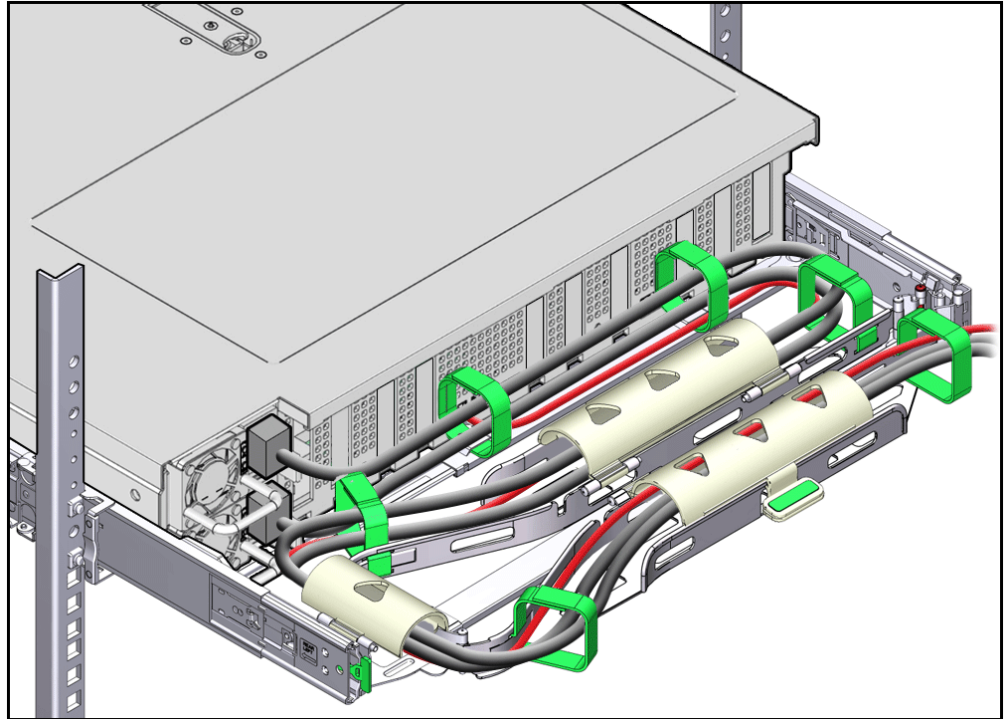

13. Ensure that the secured cables do not extend above the top or below the bottom of the server to which they are attached.

Otherwise, the cables might snag on other equipment installed in the rack when the server is extended from the rack or returned to the rack.

14. If necessary, bundle the cables with additional Velcro straps to ensure that they stay clear of other equipment.

 **Note:**

If you need to install additional Velcro straps, wrap the straps around the cables only, not around any of the CMA components. Otherwise, expansion and contraction of the CMA slide bars might be hindered when the server is extended from the rack and returned to the rack.

Index

A

- Adding
 - storage expansion shelf, [4-33](#)
- antistatic grounding strap, [4-5](#)

B

- back panel
 - features
 - Oracle Database Appliance X10-S/X10-L, [2-6](#)
 - server node features
 - Oracle Database Appliance X10-HA, [2-14](#)
 - storage shelf features
 - Oracle Database Appliance X10-HA, [2-15](#)
 - view of
 - Oracle Database Appliance X10-2-HA, [2-12](#)
 - Oracle Database Appliance X10-S/X10-L, [2-6](#)

C

- cable management arm (CMA)
 - installing on server, [4-15](#), [4-41](#)
- chassis, aligning mounting bracket with, [4-8](#), [4-34](#)
- cluster
 - supported connection, [2-1](#)
- compatibility
 - appliance components
 - Oracle Database Appliance X10-HA, [4-25](#)
 - with rack systems, [4-5](#)
- CPUs
 - configurations supported, [2-1](#)

D

- DE3-24C
 - storage shelf back panel, [2-15](#)
 - storage shelf front panel, [2-11](#)

- disk drives
 - storage, [2-1](#)

E

- electrostatic discharge, precautions, [4-5](#)

F

- fans
 - supported, [2-1](#)
- front panel
 - features
 - Oracle Database Appliance X10-S/X10-L, [2-5](#)
 - server node features
 - Oracle Database Appliance X10-HA, [2-10](#)
 - storage shelf features
 - Oracle Database Appliance X10-HA, [2-11](#)
 - view of
 - Oracle Database Appliance X10-HA, [2-9](#)
 - Oracle Database Appliance X10-S/X10-L, [2-5](#)

I

- installing
 - cable management arm, [4-15](#), [4-41](#)
 - mounting brackets, [4-8](#), [4-34](#)
 - racking, [4-1](#)
 - slide-rail assemblies, [4-13](#), [4-39](#)

M

- management software
 - supported, [2-1](#)
- marking rackmount location, [4-9](#), [4-35](#)
- memory
 - installing optional components, [4-2](#)
 - supported, [2-1](#)
- mounting brackets, installing, [4-8](#), [4-34](#)

N

- network
 - supported ports, [2-1](#)
- network adapters
 - installing optional components, [4-2](#)

O

- options
 - installing optional components, [4-2](#)

P

- PCIe
 - supported slots, [2-1](#)
- power cables, plugging into rack PDUs, [4-11](#), [4-37](#)
- power supplies
 - supported, [2-1](#)

R

- racking
 - compatibility, [4-5](#)
 - confirming compatible components
 - Oracle Database Appliance X10-HA, [4-25](#)
 - installation sequence
 - Oracle Database Appliance X10-HA, [4-25](#)
 - installing ODA X10-S/X10-L into rack, [4-7](#)
 - Installing system into rack
 - Oracle Database Appliance X10-HA, [4-23](#)
 - overview of, [4-1](#)
 - precautions, [4-4](#)
 - stabilizing the rack
 - Oracle Database Appliance, [4-7](#), [4-26](#)
 - tools required
 - Oracle Database Appliance X10-HA, [4-26](#)
 - Oracle Database Appliance X10-S/X10-L, [4-7](#)
 - using the rack anti-tilt bar
 - Oracle Database Appliance, [4-7](#), [4-26](#)
- rackmount
 - kit contents, [4-8](#), [4-34](#)
 - marking the location, [4-9](#), [4-35](#)

S

- SAS
 - supported, [2-1](#)

- serial management (SerMgt) port, [2-1](#)
- server
 - back panel features
 - Oracle Database Appliance X10-S/X10-L, [2-6](#)
 - front panel features
 - Oracle Database Appliance X10-S/X10-L, [2-5](#)
 - view of back panel
 - Oracle Database Appliance X10-S/X10-L, [2-6](#)
 - view of front panel
 - Oracle Database Appliance X10-S/X10-L, [2-5](#)
- server node
 - back panel features
 - Oracle Database Appliance X10-HA, [2-14](#)
 - front panel features
 - Oracle Database Appliance X10-HA, [2-10](#)
 - supported, [2-1](#)
 - view of back panel
 - Oracle Database Appliance X10-2-HA, [2-12](#)
 - view of front panel
 - Oracle Database Appliance X10-HA, [2-9](#)
- service processor (SP)
 - features, [2-1](#)
- setup
 - tasks, [1-1](#)
- shipping contents
 - Oracle Database Appliance X10-HA, [4-24](#)
 - Oracle Database Appliance X10-S/X10-L, [4-7](#)
- slide-rail assemblies, attaching to rack, [4-11](#), [4-37](#)
- storage
 - installing optional components, [4-2](#)
 - supported, [2-1](#)
- storage expansion shelf , [2-9](#)
 - adding to system, [4-33](#)
 - See also storage shelf
- storage shelf , [2-9](#)
 - view of back panel
 - Oracle Database Appliance X10-2-HA, [2-12](#)
 - Oracle Database Appliance X10-HA, [2-15](#)
 - view of front panel
 - Oracle Database Appliance X10-HA, [2-9](#), [2-11](#)
- support , [2-19](#)
 - for product, [2-19](#)

T

technical support

See support

TLI (Top Level Identifier)

label location

Oracle Database Appliance X10-HA,

[4-25](#)

tools

required for racking

Oracle Database Appliance X10-HA,

[4-26](#)

tools (*continued*)

required for racking (*continued*)

Oracle Database Appliance X10-S/X10-L, [4-7](#)

U

USB

supported, [2-1](#)

V

video

supported, [2-1](#)