

Oracle® Acme Packet 6300/6350

Hardware Installation and Maintenance Guide



Release 2.0

F19845-04

April 2024

The Oracle logo, consisting of a solid red square with the word "ORACLE" in white, uppercase, sans-serif font centered within it.

ORACLE®

Copyright © 2017, 2024, Oracle and/or its affiliates.

This software and related documentation are provided under a license agreement containing restrictions on use and disclosure and are protected by intellectual property laws. Except as expressly permitted in your license agreement or allowed by law, you may not use, copy, reproduce, translate, broadcast, modify, license, transmit, distribute, exhibit, perform, publish, or display any part, in any form, or by any means. Reverse engineering, disassembly, or decompilation of this software, unless required by law for interoperability, is prohibited.

The information contained herein is subject to change without notice and is not warranted to be error-free. If you find any errors, please report them to us in writing.

If this is software, software documentation, data (as defined in the Federal Acquisition Regulation), or related documentation that is delivered to the U.S. Government or anyone licensing it on behalf of the U.S. Government, then the following notice is applicable:

U.S. GOVERNMENT END USERS: Oracle programs (including any operating system, integrated software, any programs embedded, installed, or activated on delivered hardware, and modifications of such programs) and Oracle computer documentation or other Oracle data delivered to or accessed by U.S. Government end users are "commercial computer software," "commercial computer software documentation," or "limited rights data" pursuant to the applicable Federal Acquisition Regulation and agency-specific supplemental regulations. As such, the use, reproduction, duplication, release, display, disclosure, modification, preparation of derivative works, and/or adaptation of i) Oracle programs (including any operating system, integrated software, any programs embedded, installed, or activated on delivered hardware, and modifications of such programs), ii) Oracle computer documentation and/or iii) other Oracle data, is subject to the rights and limitations specified in the license contained in the applicable contract. The terms governing the U.S. Government's use of Oracle cloud services are defined by the applicable contract for such services. No other rights are granted to the U.S. Government.

This software or hardware is developed for general use in a variety of information management applications. It is not developed or intended for use in any inherently dangerous applications, including applications that may create a risk of personal injury. If you use this software or hardware in dangerous applications, then you shall be responsible to take all appropriate fail-safe, backup, redundancy, and other measures to ensure its safe use. Oracle Corporation and its affiliates disclaim any liability for any damages caused by use of this software or hardware in dangerous applications.

Oracle®, Java, MySQL, and NetSuite are registered trademarks of Oracle and/or its affiliates. Other names may be trademarks of their respective owners.

Intel and Intel Inside are trademarks or registered trademarks of Intel Corporation. All SPARC trademarks are used under license and are trademarks or registered trademarks of SPARC International, Inc. AMD, Epyc, and the AMD logo are trademarks or registered trademarks of Advanced Micro Devices. UNIX is a registered trademark of The Open Group.

This software or hardware and documentation may provide access to or information about content, products, and services from third parties. Oracle Corporation and its affiliates are not responsible for and expressly disclaim all warranties of any kind with respect to third-party content, products, and services unless otherwise set forth in an applicable agreement between you and Oracle. Oracle Corporation and its affiliates will not be responsible for any loss, costs, or damages incurred due to your access to or use of third-party content, products, or services, except as set forth in an applicable agreement between you and Oracle.

For information about Oracle's commitment to accessibility, visit the Oracle Accessibility Program website at <http://www.oracle.com/pls/topic/lookup?ctx=acc&id=docacc>.

Contents

About This Guide

1 Safety

General Safety Precautions	1-1
Fan Module	1-1
System Maintenance	1-1
Fiber Optic Cable	1-1
Environmental Specifications	1-1
Using This Guide	1-1
Electrical Safety Precautions	1-1
Precautions	1-2
Battery Warning	1-2
ESD Safety	1-2
Precautions	1-3
Environmental, Safety, and Regulatory Certifications	1-3

2 Component Overview

Chassis	2-1
Mounting Hardware	2-1
Equipment Rack Installation Hardware	2-1
Mounting Hardware	2-2
System Processor	2-3
Processor Module (CPU)	2-3
System Control Panels	2-3
Front Panel	2-3
Reset Button	2-3
Alarm LED	2-4
Power LED	2-4
Alarm Silence Button	2-4
Graphic Display	2-4
Navigation Buttons	2-4

Intake Fans	2-4
Rear View	2-5
Option Card Slots	2-6
USB	2-8
Console Port	2-8
Console Port Pin-out	2-8
Console Adapter	2-9
PWR LED	2-9
H/S LED	2-9
Alarm Port	2-10
Alarm Levels	2-10
Alarm Port Pin-out	2-10
Network Management Ports	2-11
Ethernet LEDs	2-11
Link LED	2-12
Activity LED	2-12
Signaling and Media Interfaces	2-13
Power Components	2-13
Power Supply Redundancy	2-14
AC Power	2-14
AC Power Cords	2-15
DC Power	2-15
DC Power Cords	2-15
Cooling Components	2-15
Fan	2-15
Air Filter	2-16

3 Graphic Display

Graphic Display Navigation	3-1
Display Modes	3-2
Base Display	3-2
Alarm Display	3-2
Graphic Display Menus	3-2
Top Menu	3-2
INTERFACE Menu	3-4
BOOT PARAMS Menu	3-4
SYSTEM Menu	3-5
ACTIVITY Menu	3-5
ENVIRONMENT Menu	3-6
RETURN	3-7

Graphic Display Output for HA Nodes	3-7
Initial State Displays	3-7
Out Of Service State Displays	3-7
Becoming Standby State Displays	3-7
Standby State Displays	3-7
Active State Displays	3-7

4 System Installation

Shipped Parts	4-1
Installation Tools and Parts	4-1
Recommended Tools and Parts	4-1
Rack System Instructions	4-1
Pre installation	4-2
Environmental Guidelines	4-2
Power Guidelines	4-2
Mounting Guidelines	4-3
Other Safety Guidelines	4-3
Mounting Installation	4-3
Overview	4-3
Mounting Options	4-4
Unpacking the Acme Packet 6300/6350	4-4
Cabinet-Style 4-Post Chassis Installation	4-4
Mounting System	4-4
Installing the Stationary Slides	4-5
Tapped Hole Rack Installation	4-5
Front-Mounting a Tapped Hole Rack Installation	4-5
Rear-Mounting a Tapped Hole Rack Installation	4-9
Square Hole Rack Installation	4-10
Front-Mounting a Square Hole Rack Installation	4-10
Rear-Mounting a Square Hole Rack Installation	4-14
Installing the Chassis Ears and Slides	4-17
Installing the Chassis in the Rack	4-18
Center-Mount 2-Post Chassis Installation	4-20
Installing the Center-Mount Hardware	4-20
Installing the Chassis in the Rack	4-21
Fan Module Installation	4-22
Ground and Power Cable Installation	4-22
Grounding Cable Installation	4-22
AC Power Cord Installation	4-24
DC Power Cord Installation	4-25

Cabling the Acme Packet 6300/6350 System	4-25
Console Port	4-26
Chassis Console Cabling Procedure	4-26
Alarm Port Cabling	4-27
Cabling Procedure	4-27
Network Management Ports	4-28
Cabling Procedure	4-28
Media and Signaling Network Interfaces	4-29
10GbE SFP+ Optical Cabling Procedure	4-29
Fiber Optic Cable Handling	4-29
Connecting to the Physical Interface Cards	4-30
Cabling for HA Deployments	4-30
HA Cabling	4-30
Rear Panel Cabling	4-31
Media Cabling for HA Nodes	4-32

5 Startup

Creating a Console Connection	5-1
Prerequisites	5-1
Creating a Console Connection	5-1
Powering On the Acme Packet 6300/6350	5-2
Initial Login	5-2
Formatting the Solid State Drive	5-3

6 Maintenance

System Shut Down	6-1
Shutting down the Acme Packet 6300/6350	6-1
Rejecting Incoming Calls	6-1
Shutting Down the Acme Packet 6300/6350 Console	6-2
Rebooting, Resetting, and Power Cycling	6-2
Reboot	6-2
System Reset	6-3
Power Cycling	6-4
Standby Mode for HA Nodes	6-4
Replacing an NIU in an HA Node	6-7
Chassis Removal	6-7
Removing the Acme Packet 6300/6350 from an Equipment Rack	6-7
ESD	6-9
Power Supply Removal and Replacement	6-10

Removing a Power Supply	6-11
Installing a Power Supply	6-12
NIU/TCU Removal and Installation	6-13
NIU/TCU Removal	6-14
NIU/TCU Installation	6-15
Replacing the SSM3 Module	6-17
Pre-Installation Guidelines	6-18
Required Parts	6-19
Removing the SSM3 Module	6-19
Installing the SSM3 Module	6-20
Replacing Transcoding Modules	6-22
Installation and Removal Guidelines	6-23
Required Parts	6-24
Removing the Transcoding Module	6-24
Installing the Transcoding Module	6-26
Replacing the SSD	6-28
Removing the SSD	6-28
Installing the SSD	6-30
Fan and Filter Maintenance	6-31
Remove and Install Individual Fans	6-31
To Install a Fan	6-34
Maintaining the Cooling Components	6-35
Cleaning the Cooling Components	6-36
SFP+ Removal and Replacement	6-36
SFP+ Media Signaling Interfaces	6-37
SFP+ Information	6-37
SFP+ Identification	6-37
Media Cables	6-37
Cable Information	6-38
Cable Identification	6-38
Removing an SFP+	6-39
Replacing an SFP+	6-40
Alarms	6-40
Hardware and Environmental Alarms	6-41
Hardware Temperature Alarm	6-41
Fan Speed Alarm	6-46
Power Supply Alarms	6-49
Voltage Alarms	6-49
Link and SDP Alarms	6-52
Media Ethernet Link Alarms	6-52
Management Ethernet Link Alarms	6-53

7 Specifications

Environmental, Safety, and Regulatory Certifications	7-1
Physical Specifications	7-1
Acme Packet 6300/6350 System Chassis Specifications	7-1
AC Power Supply Physical Dimensions	7-1
DC Power Supply Physical Dimensions	7-1
Fan Module Specifications	7-2
Electrical Specifications	7-2
Power Supply Input Circuit Fuse Requirements	7-2
Alarm Port Dry Contact Current Limits	7-2
Environmental Specifications	7-3
Connector Specifications	7-3
Optical Transceiver Interface Module Specification	7-3

8 Acronyms, Definitions, and Terms

About This Guide

The Acme Packet 6300/6350 is a high performance, high capacity session border controller that optimally delivers interactive communications — voice, video, and multimedia sessions — across wireline, wireless, and cable IP network borders. With its 3U design the Acme Packet 6300/6350 provides exceptional functionality in a tightly integrated system. This chapter provides an introduction and overview of the Acme Packet 6300/6350 main components.

Revision History

This section contains a revision history for this document.

Date	Description
September 28, 2012	First Draft Acme Packet 6300 Hardware Installation Guide
September 29, 2012	Added updates to document
October 3, 2012	Added updates to the Alarms section
October 4, 2012	Added updates to the Boot Parameter section
October 5, 2012	Added updates to the Alarms section
November 14, 2012	Added updates to the power source sections Acme Packet 6300 Hardware Installation and Maintenance Guide Added VCCI-B Certification
December 18, 2012	Added the halt command Added the terminology Storage Device Changed a picture in the mounting section
January 9, 2013	Added the locking mechanism to the guide rail section.
Mat 7, 2013	Added reference connect NIU removal
May 9, 2013	Updated Optical Trans section
Aug 16, 2013	Updated Specification section
November 11, 2013	Removed all instances of Net-Net
February 24, 2014	Added these new sections: - TCM Removal and Replacement - Replacing the SSM3 Module - Installing SODIMMs - Replacing Transcoder DSP Modules - Replacing the SSD Formatted photos and tables to conform to new standard
October 16, 2014	Changed references to Media Ports from GigE to 10GbE to clarify Media Port speed. Updated Heat and Power Dissipation information in the Specifications chapter.

Date	Description
November 10, 2014	Entered a note in the Maintenance Introduction pointing out that after you replace an SSD, you must format it. Corrected VCCI references.
January 15, 2015	Renamed the document to reflect the merge of the Installation and Service manuals. Removed Regulatory Specifications and Certifications from the Specifications chapter. Inserted reference to Acme Packet Platforms Safety and Compliance Guide. Inserted an updated Oracle copyright page.
April 20, 2015	Inserted language to confirm that Acme Packet 6300 hardware installation documentation satisfies NEBS (Network Equipment-Building System) requirements. Entered a note at the end of the Startup chapter pointing out that after you initially sign on to an Acme Packet 6300 after installation, you must format the solid state drive.
August 8, 2017	Adds support for Acme Packet 6350.
January 11, 2019	Adds the Oracle accessibility statement to "About This Guide".
July 2020	Updates "NIU Removal and Installation" with new images and notes. Updates "DC Power Cords" with information on a new cord.
December 2020	Adds note about multiple sensors reporting alarms with the same Alarm ID.
April 2024	Removes claim that air filter is not FRU.

1

Safety

This chapter provides an overview of the recommended safety precautions for installing the Acme Packet 6300/6350.

Before you install your Acme Packet 6300/6350, Oracle recommends that you review the contents of this chapter. This chapter provides information intended to protect you and your Acme Packet 6300/6350 from experiencing any harm during the installation process. This chapter also provides information that helps keep your Acme Packet 6300/6350 functioning properly and protect it from damage.

General Safety Precautions

To ensure general safety, follow the safety precautions listed in this section.

Fan Module

To avoid overheating the system, do not block the air inlets or the fan module, or otherwise obstruct airflow to the system. Keep the area around the Acme Packet 6300/6350 clean and clutter-free.

System Maintenance

Aside from the power supply, fan module, and NIUs, there are no user-serviceable parts inside the Acme Packet 6300/6350. Only professionals trained to maintain, adjust, or repair the Acme Packet 6300/6350 may provide these services.

Fiber Optic Cable

Looking into a fiber optic cable can cause eye damage. Never look directly into the end of the fiber optic cables. Instead, use a fiber optic power meter to determine if power is present.

Environmental Specifications

Adhere to the Environmental Specifications section in the Specifications chapter of this guide.

Using This Guide

Read and understand all notes of warning and caution included in the Acme Packet 6300/6350 documentation. These warnings and cautions are designed to keep you safe and protect the Acme Packet 6300/6350 from damage.

Electrical Safety Precautions

To protect yourself from harm and the Acme Packet 6300/6350 from damage, follow the electrical safety precautions listed in the following subsections.

Precautions

- Note the locations of the power supply switches on the Acme Packet 6300/6350.
- Note the location of the emergency power-off switch for the room where the Acme Packet 6300/6350 is located.
- If an electrical accident occurs, remove power from the system immediately by unplugging the chassis.
- Always disconnect the power from the system when removing a Acme Packet 6300/6350 from its rack.
- When disconnecting power:
 - Disconnect the circuit breaker at the rack.
 - Unplug or unscrew the power cords from the power supplies.
- Use grounded AC power cords that are plugged into grounded electrical outlets.
- Never use extension cords to power a Acme Packet 6300/6350.
- Ensure that the installation facilities have proper grounding systems and include a grounded rack structure or local grounding bus bar.
- When installing the Acme Packet 6300/6350 in an equipment rack, always make the ground connection first and disconnect it last upon uninstallation.
- Use shielded Category 5e or 6, RJ45 cables for all 10/100/1000 Ethernet connections to protect the Acme Packet 6300/6350 from potential damage.
- To avoid making a complete circuit (which causes electrical shock), use only one hand when working with powered-on electrical equipment.
- Use caution when using electrically conductive tools around the Acme Packet 6300/6350.
- Remove jewelry before working on the Acme Packet 6300/6350.

Battery Warning



Note:

RISK OF EXPLOSION IF BATTERY IS REPLACED BY AN INCORRECT TYPE. DISPOSE OF USED BATTERY ACCORDING TO THE INSTRUCTIONS.

Perchlorate Material — Special handling may apply. See www.dtsc.ca.gov/hazardouswaste/perchlorate.

ESD Safety

To protect the Acme Packet 6300/6350 delicate electronic components from damage from static electricity, always follow the appropriate ESD procedures and wear the proper protective devices (such as an ESD wrist strap) when handling any and all Acme Packet 6300/6350 hardware and while performing any Acme Packet 6300/6350

System hardware procedures. There is an ESD receptacle in the top left corner in the rear of the Acme Packet 6300/6350.

Precautions

To protect your equipment from ESD, follow these ESD safety precautions:

- Ensure that the Acme Packet 6300/6350 is properly grounded.
- If you are grounding your Acme Packet 6300/6350 to an electrically conductive, grounded rack, check to see whether or not the rack is painted. Paint can hinder proper grounding. If your equipment rack is painted, you should ground the system to some other reliable place or remove a small portion of paint for proper grounding.
- Use a grounded ESD wrist strap when working on the Acme Packet 6300/6350 to prevent static discharge.
- To avoid damaging ESD sensitive hardware, discharge all static electricity from your body before working directly with the Acme Packet 6300/6350 by touching a grounded object.



ESD Wrist Strap

Environmental, Safety, and Regulatory Certifications

For specific information regarding the environmental, safety, and regulatory certifications applicable to the Acme Packet 6300/6350 refer to the Environmental, Safety, and Regulatory Certifications section included in this guide's Specifications chapter.

2

Component Overview

Chassis

The Acme Packet 6300/6350 is contained in a 3U rack-mounted chassis. It can be front- or center mounted in standard 19" wide racks (up to 32" deep), with options for 23" wide racks.



Acme Packet 6300/6350 - Front View



Acme Packet 6300/6350 - Rear View

Mounting Hardware

The Acme Packet 6300/6350 is supported by a pair of slide rails that are affixed to an equipment rack by front and rear mounting flanges. The slide rails are adjustable for equipment racks of various depths.

Equipment Rack Installation Hardware

For equipment rack installations, the Acme Packet 6300/6350 ships with both left and right stationary slide rails and chassis slide rails, as well as all required spacers, nut bars, and screws.

The following diagram shows all of the equipment rack installation hardware that ships with the Acme Packet 6300/6350.

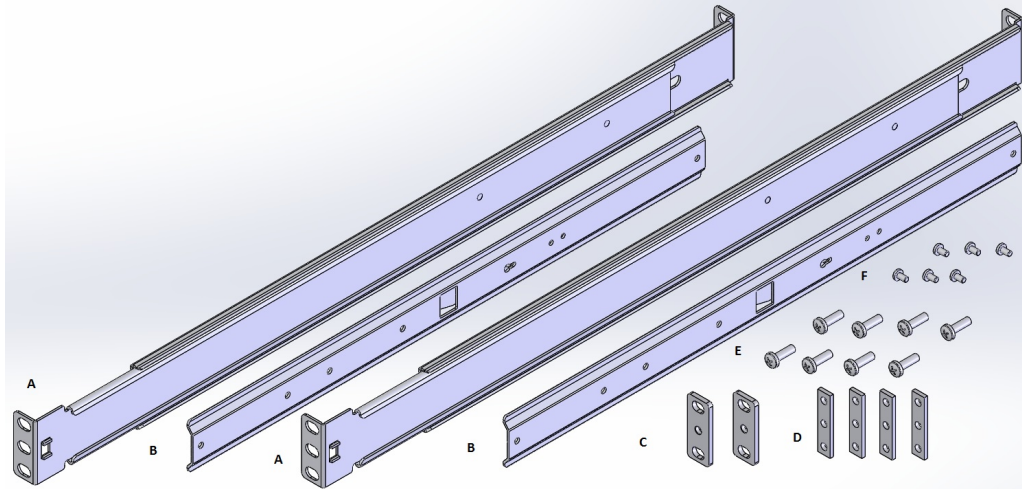

- **A**—Left and right stationary slide rails
- **B**—Left and right chassis slide rails
- **C**—Spacers
- **D**—Nut bars
- **E**—#10-32 x 5/8 pan head screws
- **F**—#6-32 x 5/16 pan head screws

Mounting Hardware

The following diagram shows the mounting hardware that ships with the Acme Packet 6300/6350.

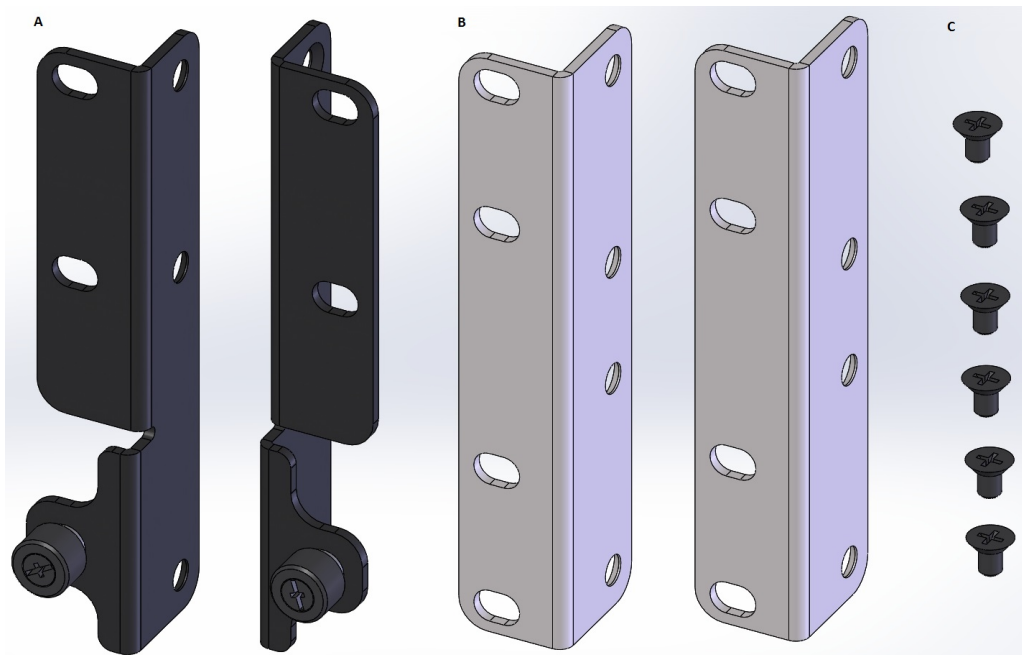

- **A**—Front Mounting Flanges
- **B**—Mounting Ears
- **C**—#10-32 x 5/16 Flat Head Screws

System Processor

Processor Module (CPU)

The Acme Packet 6300/6350 processor module (CPU) is located on the main board of the Acme Packet 6300/6350 System as a daughter card. This processor module handles both the management and signal processing within the system. The CPU interacts with the Network Processor (NP) to perform call and media control.

System Control Panels

This section describes the Acme Packet 6300/6350 front and rear control panels.

Front Panel

The Acme Packet 6300/6350 front control panel provides easy access to several system components. On the control panel you can access the graphic display, navigation buttons, reset button, alarm LED, alarm silence button, alarm LED and power LED.



Acme Packet 6300/6350 Front Panel

Reset Button

Reset the Acme Packet 6300/6350 by pressing the front panel's reset button. This button is recessed, and can only be pressed by inserting a thin wire, such as a paper clip, through the reset button channel. Accidentally pressing the reset button can result in the loss of software data or your configuration.

Pressing the reset button causes a hard reset, immediately rebooting the Acme Packet 6300/6350. After the reset button is released, the Acme Packet 6300/6350 begins its boot

sequence and loads the configured software file.



Alarm LED

The alarm LED on the front control panel indicates if any alarms are active on the Acme Packet 6300/6350. The LED can be three different colors to indicate the severity of the alarms.

- Unlit- system is fully functional without any faults
- Amber- major alarm has been generated
- Red- critical alarm has been generated.

Power LED

The green power LED indicates the power is on.

Alarm Silence Button

The alarm silence button clears the alarm table internally and opens the alarm circuits connected to the network interface unit's alarm port.

Graphic Display

The graphic display is a four-line VFD display window on the Acme Packet 6300/6350 front control panel that reports real-time status, alarms, and general system information.

Navigation Buttons

You use the navigation buttons to navigate through the menus and information visible on the graphic display.

Intake Fans

Fifteen individual intake fans keep the Acme Packet 6300/6350 cool by pulling air through the front panel and exhausting heated air through the rear of the chassis. The fans are covered by a particle filter that prevents excess dust and contaminants from entering the system.

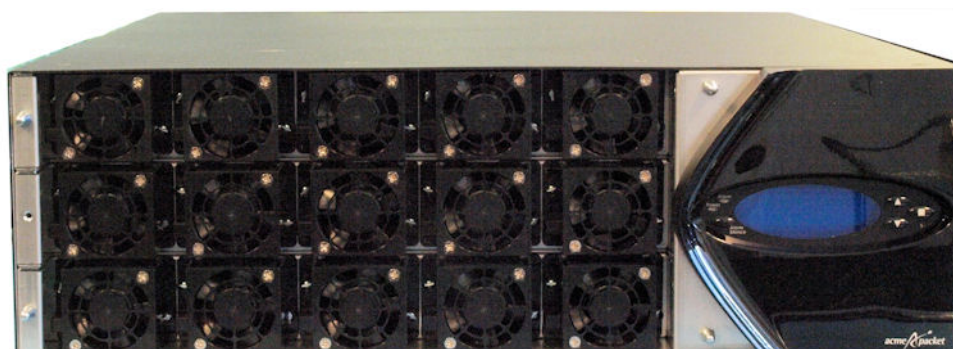

Intake Fans

Rear View

Power supplies and the Option Cards are located in the rear of the chassis. There is a slight difference in the rear chassis of the Acme Packet 6300 and Acme Packet 6350. The Acme Packet 6350 has a System Power switch, which enables you to control the power to the Acme Packet 6350. This is useful when you want to shut off power to the Acme Packet 6350 without having to unplug the power cord. The Acme Packet 6300 does not have a System Power switch.

The System Power switch has the following switch settings:

- STBY—when selected, the Acme Packet 6350 powers down. While the system is in standby mode, the power supply remains active, and the fans inside of the power supply run as necessary. The fans in the front of the chassis do not run. This convenient feature enables the system to be shut down without having to withdraw the power supply or disconnect the power supply cord.

 **Note:**

Standby mode (STBY) is not the same as standby state. Standby state refers to the system state of a Acme Packet 6350 that is part of a high availability pair (HA pair).

- ON—applies power to the Acme Packet 6350. This switch position is used during normal operation.

 **Caution:**

The System Power switch should remain in the ON position at all times. Do not touch a System Power switch unless specifically instructed to do so by your customer support representative or you are following instructions in this guide.

Two LEDs are present under the System Power switch:

- STBY—This LED is enabled when the system is in standby power mode. The LED is inactive when the system is powered up and running.
- DIS— This LED is enabled when the console serial port is disabled via software. The LED is inactive when the serial console port is enabled.

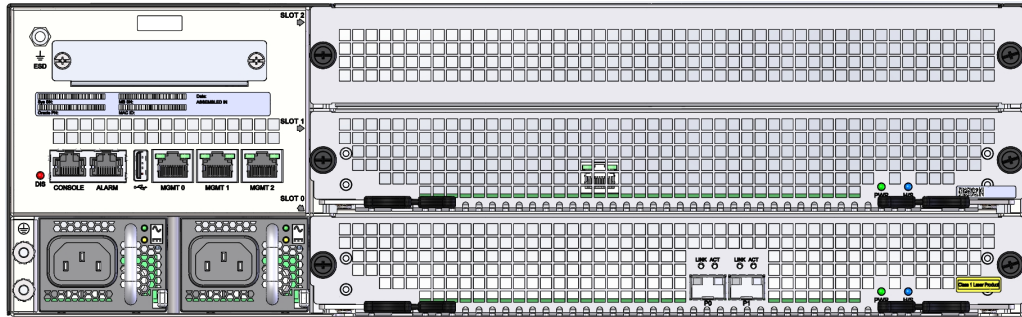

Acme Packet 6300 Rear View with AC Power Supplies and Option Cards

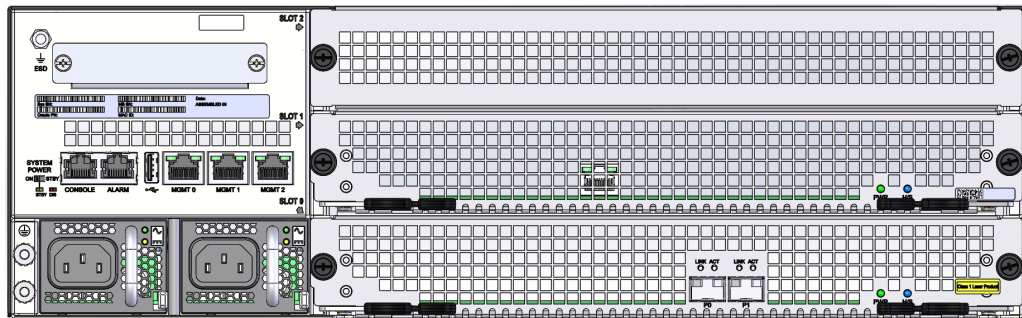

Acme Packet 6350 Rear View with AC Power Supplies and Option Cards

 **Note:**
The Acme Packet 6350's rear external USB 3 port is not functional.

Option Card Slots

The Acme Packet 6300/6350 contains three slots located on the right side of the rear of the chassis. The slots are labeled Slot 0, Slot 1, and Slot 2 (from bottom to top), as shown in the following image.

Figure 2-1 Rear Panel Slot Indicators



The following images show Small form-factor pluggable (SFP+) media network ports on the Network Interface Unit (NIU) cards.

Figure 2-2 NIU SFP+ Media Network Ports



Figure 2-3 Typical Option Card - Two Port NIU

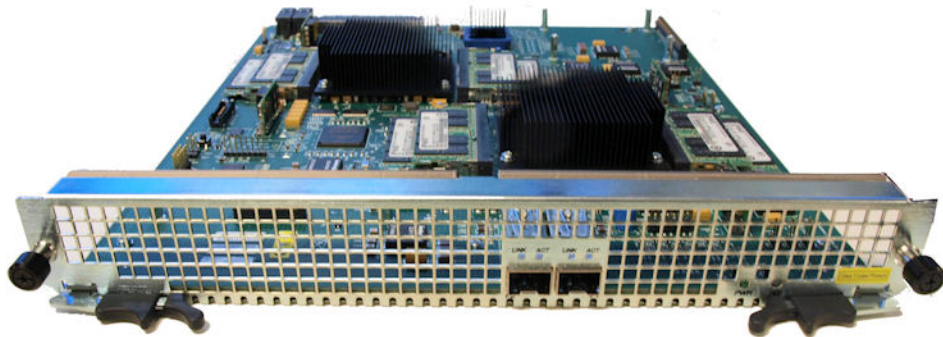

Figure 2-4 Alternate Option Card - Four Port NIU in Chassis

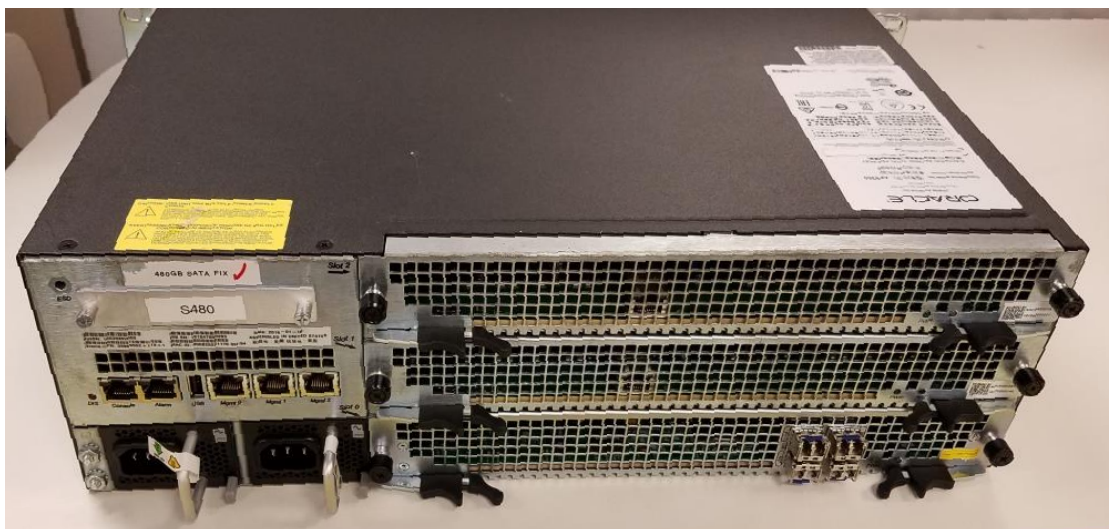

Figure 2-5 Alternate Option Card - Four Port NIU

USB

The USB port is reserved for software-enabled applications. The USB port is located in the rear left side of the chassis. The USB port is for Acme Packet use only and is not to be used by the customer.

Console Port

The Option Card port, located on the rear left side of the chassis, provides console access to the Acme Packet 6300/6350 over an RS-232C serial connection. The console port is useful for customers who want permanent console access to the Acme Packet 6300/6350.

Console port communication is used for administration and maintenance purposes from a central office (CO) location. Tasks conducted over a console port include:

- Creating the initial connection to the Acme Packet 6300/6350
- Accessing and using all functionality available via the ACLI
- Performing in-lab system maintenance

Console Port Pin-out

The Acme Packet 6300/6350 System console port is accessed through the RJ45 jack in the rear of the system. Because the Acme Packet 6300/6350 does not employ any type of flow control on its RS-232 ports, only the RX, TX, and GND pins are used. The following table identifies the pin assignments and signal names/descriptions for the console connector.

Table 2-1 Console Port Pin-Out

Pin Number	Signal Name/Description
3	Receive Data (RX)
4	Ground (GND)
6	Transmit Data (TX)

Console Adapter

A standard RJ45 to DB-9 serial console adapter is shipped with your Acme Packet 6300/6350. This adapter converts from an Ethernet cable's RJ45 plug to a standard DB-9 serial port jack, found on a PC or laptop. Any standard Ethernet cable can be used between the Acme Packet 6300/6350 and the console adapter.



RJ45 to DB-9 Serial Console Adapter

PWR LED

The green PWR LED indicates the operational state of the Option Card.

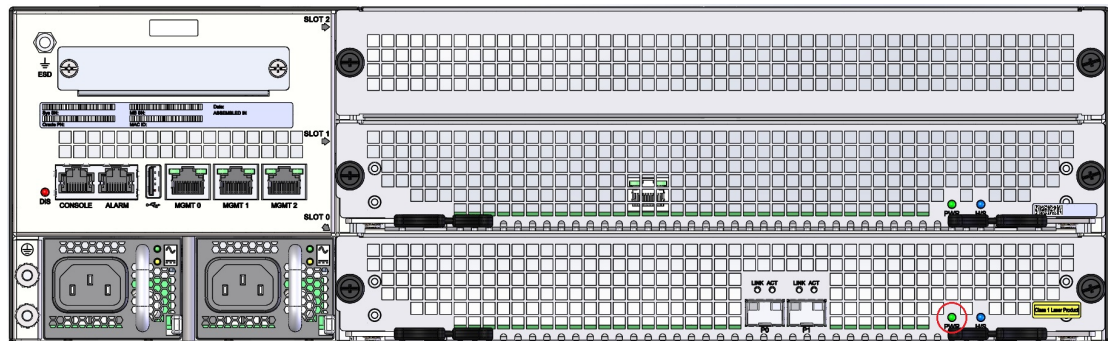

PWR LED

Possible states of the PWR LED include:

- on — indicates that power is being applied to the Option Card.
- off — indicates that power is not being applied to the Option Card.

H/S LED

The blue H/S LED indicates whether the Option Card is seated properly.

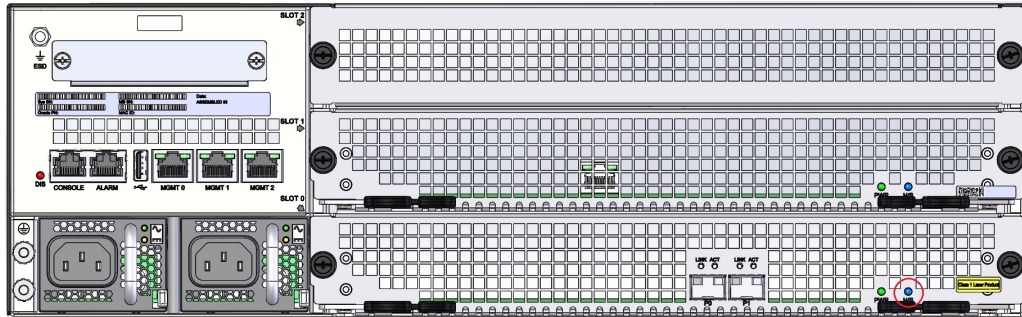

H/S LED

Possible states of the H/S LED include:

on/blinking — indicates that the Option Card is not seated properly. When this occurs, ensure that you remove power to the platform and attempt to properly lock the Option Card to the chassis. Then apply power to the chassis. If the H/S LED is no longer lit, proceed with normal operations.

off — when the PWR LED is on, this indicates that the Option Card is seated properly in the chassis.

Alarm Port

The alarm port on the Acme Packet 6300/6350 is a flexible interface that closes a circuit when a specific alarm level becomes active on the Acme Packet 6300/6350. An alarm control signal interface on the Acme Packet 6300/6350 can be used in a CO location to indicate when internal alarms are generated. The Acme Packet 6300/6350 uses alarm levels that correspond to three levels of service-disrupting incidents. When one of the three alarm levels is generated, the corresponding circuit for that level on the alarm port is closed.

Alarm Levels

The following table lists the three alarm levels.

Table 2-2 Acme Packet 6300/6350 Alarm Types

Alarm Type	Description
Minor	Functionality has been impaired to a small degree (e.g., a single fan has failed).
Major	Pending failures or unexpected events have occurred (e.g., a loss of signal).
Critical	A catastrophic condition has occurred (e.g., the system is overheating).

The alarm port uses a standard RJ45 connector.

Alarm Port Pin-out

The following table lists the pin assignments for the RJ45 alarm port.

Table 2-3 Acme Packet 6300/6350 Alarm Port Pin-Outs

Pin Number	Signal Name/Description
1	Minor Alarm (Pin 1)
2	Minor Alarm (Pin 2)
3	Major Alarm (Pin 1)
4	Major Alarm (Pin 2)
5	Critical Alarm (Pin 1)
6	Critical Alarm (Pin 2)
7	Ground
8	Ground

Network Management Ports

The Acme Packet 6300/6350 has three 10/100/1000 Base-T Ethernet ports located in the rear left side of the chassis. These ports are labeled Mgmt0, Mgmt1 and Mgmt2. These ports are used for EMS control, RADIUS accounting, CLI management, SNMP queries and traps, and other management functions.

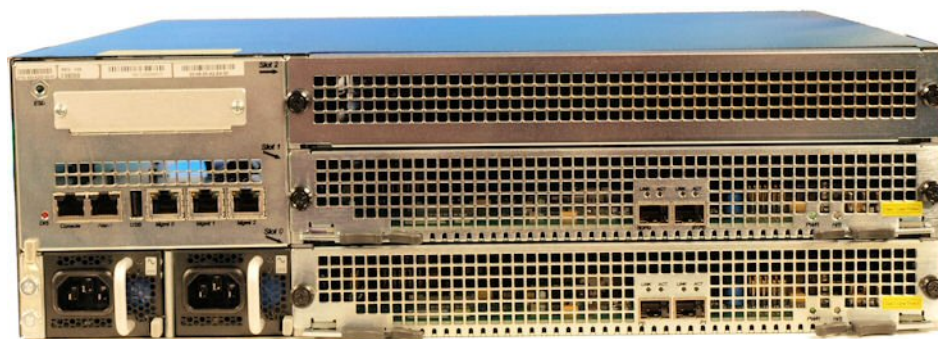

Network Management Ports

Ethernet LEDs

Each Ethernet jack has two integrated LEDs, one to indicate Link, and one to indicate Activity. The LED pair is located directly above its associated port. These LEDs are explained in the following sections.

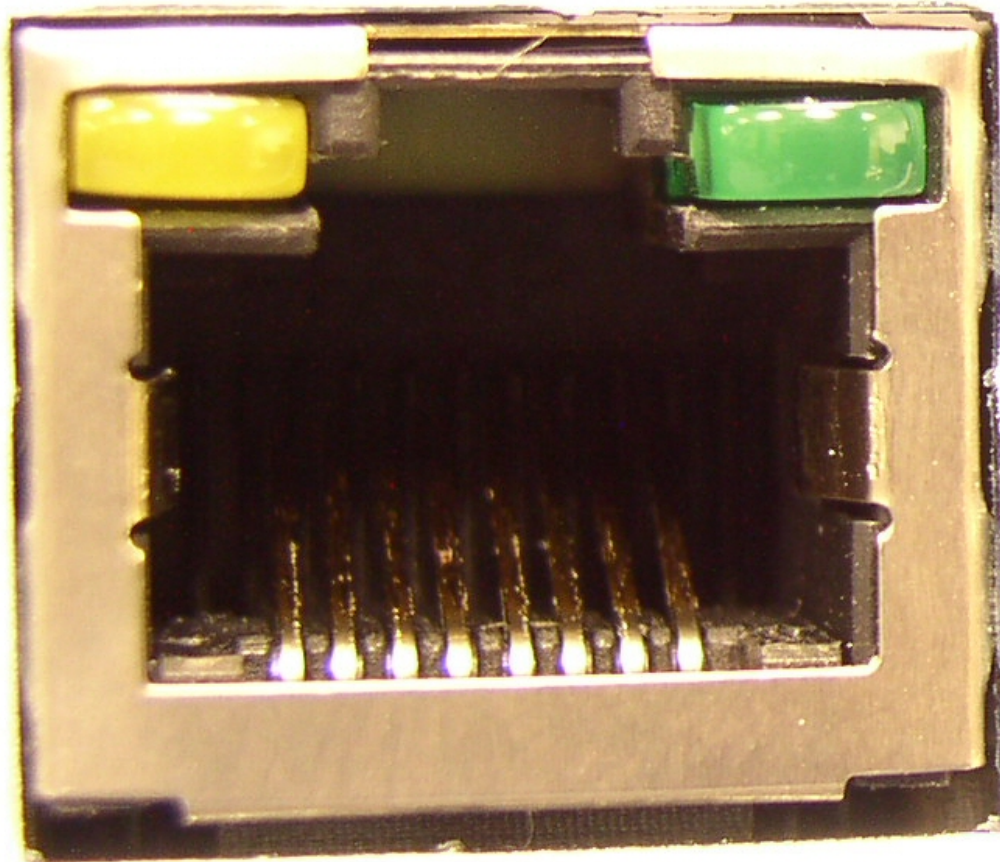

Ethernet Link LED (left) and Activity LED (right)

Link LED

The link LED illuminates orange when a link has been established between the link partner device and the SBC.

Activity LED

The activity LED is located to the top right side of the Ethernet port. It illuminates green when an Ethernet connection has either transmit or receive packet activity.

Upon initial bootup, these Ethernet ports are not configured. You must first connect to the Acme Packet 6300/6350 over a serial connection before you can configure the management Ethernet ports for use. You set up the management interfaces using the physical and network interface configuration elements. Refer to the System Configuration chapter of the Acme Packet Configuration Guide for details.

Once the management network interface is configured, it should be reserved for the following:

- Maintenance activities
- Application log retrieval
- Software upgrades
- System configuration

- Telnet, SSH, SNMP, FTP, and SFTP connections
- RADIUS CDR transmission

Oracle Acme Packet recommend that you use shielded CAT5e or CAT6 Ethernet cables with RJ45 plugs for connecting to the rear-panel Acme Packet 6300/6350 Ethernet interfaces. These Ethernet interfaces have a distance limitation of 328 feet (100 m) as defined by the FAST Ethernet standard, IEEE 802.3.

Signaling and Media Interfaces

The signaling and media interfaces provide network connectivity for signaling and media traffic. Each interface can connect to a network at 10-Gigabit speeds.

Network Interface Units (NIUs) are available in the following configurations:

- 2-port 10GbE NIU
- 4-port 10GbE NIU

The optical 10GbE cards can accept an LC fiber connector using either single mode or multimode cable.

Mixed transceiver types are not supported on SFP+-based NIUs because compliance testing shows that the NIU SFP+ ports must be populated with identical SFP+ types.

The Acme Packet 6350 supports the 4x10GbE NIU to provide greater session scaling and Packet Processing Module (PPM) support. The 4x10GbE NIU contains two Cavium 78xx chips running in parallel, and each one is attached to two 10GbE media interfaces. Each chip contains 64GB of DDR4 RAM. The increase in DDR4 RAM enables greater scaling capacity, and the use of DDR4 running at 1050MHz provides a memory performance boost.



Note:

When using the 4x10GbE NIU, you must put it in slot 0.

Power Components

Acme Packet offers AC or DC power options for the Acme Packet 6300/6350. The power supplies are user-replaceable, hot swappable components. There are no ON/OFF switches on the AC or DC power supplies.

Power supplies are accessed from the rear panel of the system chassis. The right power supply is designated as power supply A, and the left power supply is designated as power supply B.

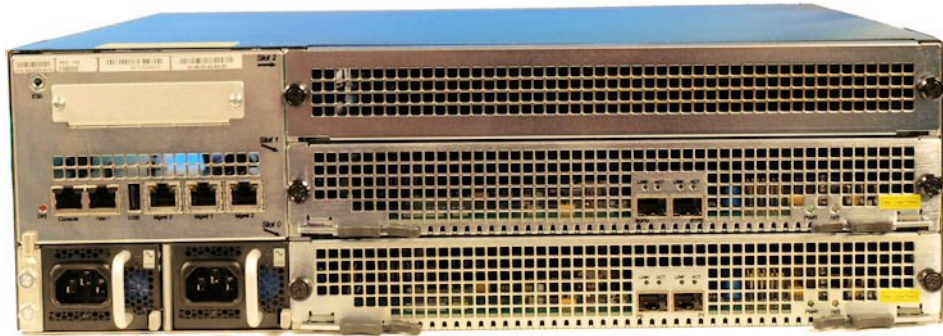

AC Power Supplies

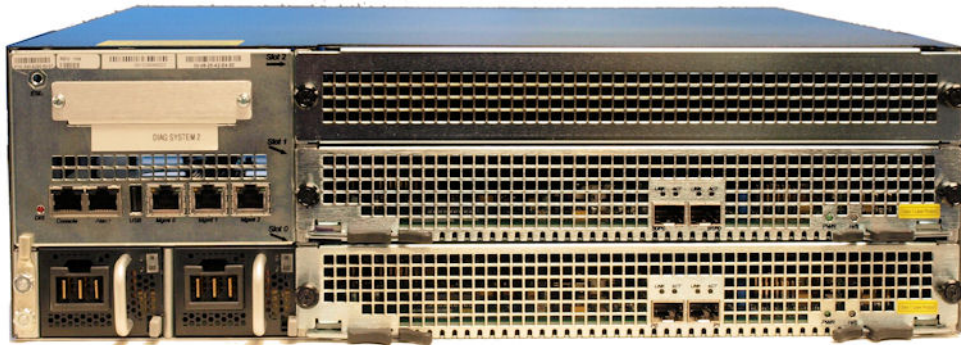

DC Power Supplies

Power Supply Redundancy

During normal operation, the Acme Packet 6300/6350 is load-balanced and draws power from both supplies. The two power supplies also provide hardware redundancy. If a power supply fails, the Acme Packet 6300/6350 can rely on only one functional power supply to sustain normal operation. A malfunctioning power supply must be removed and replaced as soon as possible. If the Acme Packet 6300/6350 starts up with only one power supply, it will not generate an alarm.

AC Power

The handle on the front panel of the power supply is used to insert and remove the power supply from the chassis. The grey locking handle, when moved from right to left, unlocks the power supply from the chassis.



AC Removal/Installation Latch and Handle

AC Power Cords

All AC-powered Acme Packet 6300/6350 systems ship with two 2.5m power cords. Each power cord connects to the IEC-320 C14 receptacle on the power supply. There is no ON/OFF switch on these power supplies.

DC Power

The Acme Packet 6300/6350 can be powered by central office –48 VDC operations with a DC-DC supply. The handle on the front panel of the power supply is used to insert and remove the power supply from the chassis. The locking handle is used to lock/unlock the power supply from the chassis. A terminal block on the DC power supply serves as the DC power interconnect.

DC Power Cords

A DC power cable ships with each DC power supply. Each DC power cable is eight feet long. 3-conductor, 10 AWG cable with a three-position connector on the power supply end with a minimum rating of at least 140° F (60° C). The supply end of each wire is stripped and tinned for attachment to your rack's circuit breaker or power supply. There is no ON/OFF switch with these power supplies. The following table lists the DC power cord wire markings.

Table 2-4 Acme Packet 6300/6350 DC Power Cord Wire Markings

Wire Color	Standard Cord	Alternate Cord
Red	Return	-48 VDC
Green/Yellow	Frame Ground	Frame Ground
Black	-48 VCD	Return

Grounding Terminals

The grounding terminals are used to attach the Acme Packet 6300/6350 chassis to a local earth ground. The terminals are located to the left of the two power supplies on the rear of the chassis.

Cooling Components

The Acme Packet 6300/6350 must remain well ventilated for reliable and continuous operation. The cooling features of the chassis include:

- 15 individual fans
- 1 fan filter

Fan

The Acme Packet 6300/6350 chassis draws cool ambient air through the chassis through intake fans and is exhausted through perforated air outlets located along the rear of the chassis. To avoid overheating the system, do not block the air intake or exhaust ways or otherwise obstruct airflow to the system in any way.

The following figure shows one Acme Packet 6300/6350 fan. The individual fan attaches to the chassis with two captive screws, and is powered by a connector that joins to the motherboard when screwed into the chassis.

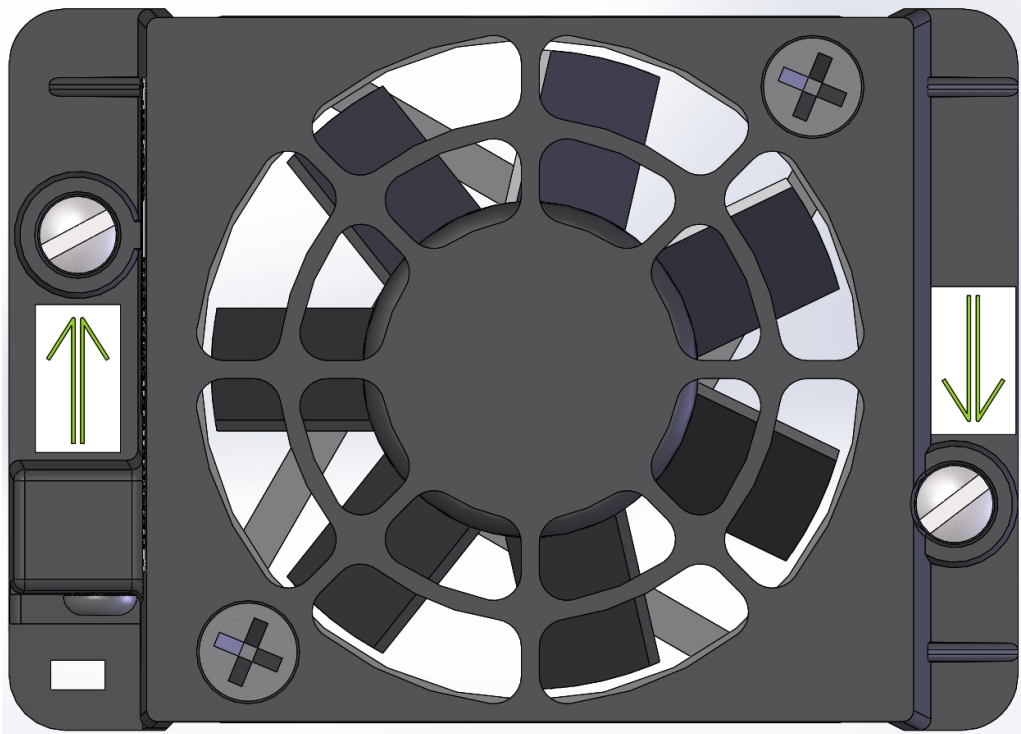

Fan Installation/Removal Screws

The Acme Packet 6300/6350 automatically adjusts fan speed based on the current operational status and environmental conditions. Fan speed regulation is an automated process that requires no user intervention. You can monitor the status of the fan speed from the Environment menu of the graphic display.

If the Acme Packet 6300/6350 experiences a fan module malfunction and generates an alarm, you must remove the existing fan module and replace it with a fully functioning fan module. A visible FAULT LED identifies the malfunctioning Fan.

Air Filter

The Acme Packet 6300/6350 air filter removes airborne particles before they are drawn into the system chassis.

Oracle sells replacement air filters.

3

Graphic Display

To the left the 4-line graphic display on the Acme Packet 6300/6350 front control panel is visible at all times. To the right the buttons used to navigate the display are accessible as well. The graphic display reports real-time status, alarms, and general system information. You can view this information without using a console, telnet, or SSH connection into the Acme Packet 6300/6350.

Graphic Display Navigation

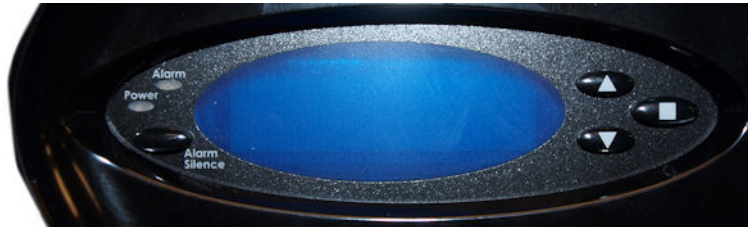

Three navigation buttons are located to the right of the display. These are used to scroll through display menus and select the information to view on the graphic display.



Acme Packet 6300/6350 Graphic Display and Control

The following table lists the function of each graphic display button.

Table 3-1 Acme Packet 6300/6350 Graphic Display Button Functions

Button	Description
Up	Scrolls up through the previous menu or display items, one line at a time.
	
Down	Scrolls down through the next menu or display items, one line at a time.
	
Enter	Selects the menu or display item that appears in the graphic display window.
	

Display Modes

The Acme Packet 6300/6350 graphic display defaults to one of two display modes:

- Base display is the default and indicates a properly-functioning Acme Packet 6300/6350.
- Alarm mode becomes the default display mode when any alarms are active on the Acme Packet 6300/6350. Active fault information is continuously displayed on the graphic display.

Base Display

The base display shows the type of Acme Packet 6300/6350 running. This information appears when the system first starts up and when the graphic display times out at any menu level.

```
NET - NET
```

```
SESSION DIRECTOR
```

The base display of a Acme Packet 6300/6350 in an HA node includes additional information applicable to its HA state. See the "[Graphic Display Output for HA Nodes](#)" section in this chapter.

Alarm Display

The alarm display replaces the base display during an alarm condition. The alarm display informs you of what symptoms are currently causing alarms. The number and type of alarms appear on the Acme Packet 6300/6350 graphic display, which indicates either a link alarm or a hardware alarm. For example, if there are two link alarms present on the Acme Packet 6300/6350, the display appears like this:

```
2 LINK ALARMS
```

If the graphic display indicates an alarm condition, you can use the ACLI **display-alarms** command to display the details of the alarm. When an alarm condition is cleared, the base display replaces the alarm display. To clear an alarm, you must execute the ACLI **clear-alarm** command or resolve the cause of the alarm.

Graphic Display Menus

The Acme Packet 6300/6350 graphic display lets you access the five display menus for quick access to the system's current status.

Top Menu

The top menu provides top-level access to information in distinct categories of system functionality.

To access the top menu from the base display or alarm display:

1. Press the **Enter** button. The first entry in the top menu appears.

- Press the **Up** and **Down** buttons to scroll through the top menu categories. The top menu rolls over when you reach the top or bottom of the menu.

The top menu displays only one category at a time. You press the **Enter** button to select a displayed category and show its submenu information.

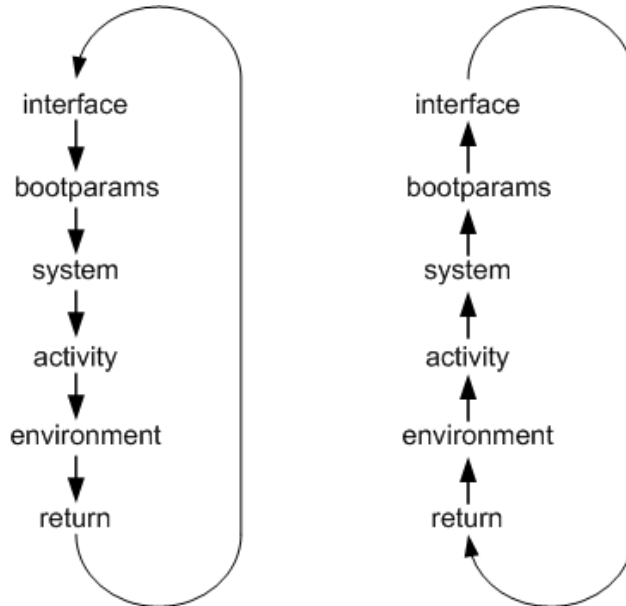

Scrolling Through Menu Categories on the Graphic Display

After 30 seconds of displaying a menu option or submenu information without any user input, the system automatically returns to the base display during normal operating conditions, or to the alarm display during an alarm condition.

The following diagram shows the complete menu of options available from the graphic display. Lines in black indicate results from pressing the **Up** or **Down** buttons. Lines in blue indicate results from pressing the **Enter** button.

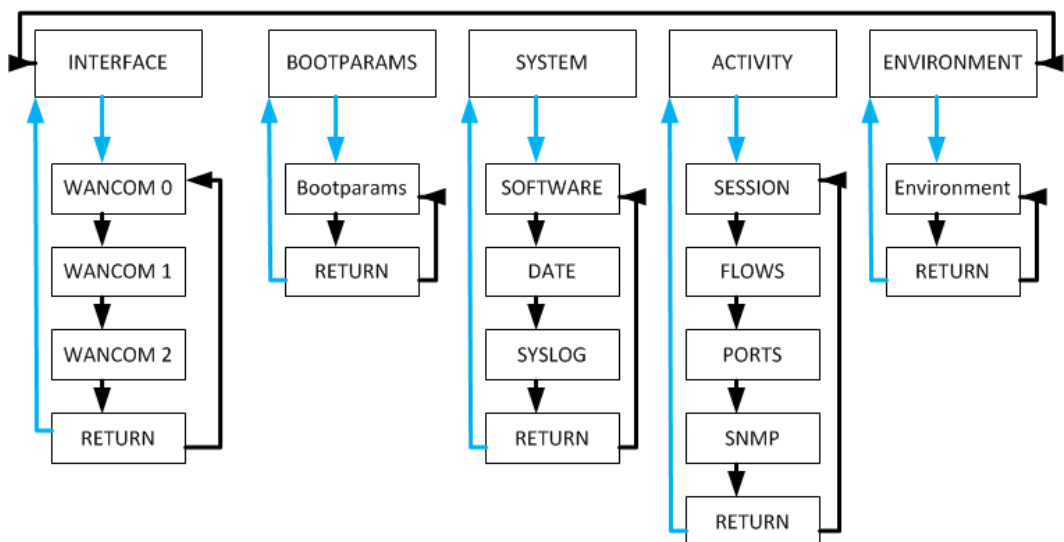

Acme Packet 6100 Menu Options (Exploded View)

INTERFACE Menu

The INTERFACE menu allows you to scroll through a list of all configured physical interfaces. The management and media physical interfaces appear in the list, as does the loopback interface.

The following information is displayed for each configured interface to which you scroll:

- Interface slot and port: interface status
- Input packets, output packets
- Input error packets, output error packets

Slot 1: Port0 UP

PKT IN: 1,001K OUT: 223K

ERR IN: 0 OUT: 0

To exit the INTERFACE menu in the graphic display:

1. From the top menu of the graphic display, press the **Enter** button.
2. Press the **Up** or **Down** button to scroll to the INTERFACE selection.
3. Press the **Enter** button.
4. Press the **Up** or **Down** button to scroll through the list of configured physical interfaces.
5. Press the **Enter** button to refresh the display.
6. Press the **Up** or **Down** button to scroll to the RETURN selection.
7. Press the **Enter** button to return to the Top Menu.

BOOT PARAMS Menu

The BOOT PARAMS menu allows you to view the same information configured in the **bootparam** ACLI configuration. The BOOT PARAMS selection displays the IP information necessary to connect to the first Ethernet interface, eth0, located on the left side on the back of the Acme Packet 6300/6350. This interface is used primarily for maintenance, configuration, and downloading software images.

The following information for eth0 is displayed under the BOOT PARAMS menu:

- IP address
 - Netmask
 - Gateway IP address
- inet: 192.168.0.2
mask: 255.255.255.0
gw: 192.168.0.1

To exit the BOOT PARAMS menu in the graphic display:

1. From the top menu of the graphic display, press the **Enter** button.
2. Press the **Up** or **Down** button to scroll to the BOOT PARAMS selection.
3. Press the **Enter** button. The BOOT PARAMS information is displayed.

4. Press the **Up** or **Down** button to scroll to the RETURN selection.
5. Press the **Enter** button to return to the Top Menu.

SYSTEM Menu

The SYSTEM menu allows you to view the system software and current date. The following information displays two screens in the graphic display in the order listed:

- Screen 1 — Acme Packet 6300/6350 System software version and creation date:
Software:

ACME OS 6.0.0

01/01/2008

- Screen 2 — Current day, memory utilization:
Date 10:04:12

MEMORY 65%

To exit the SYSTEM menu in the graphic display:

1. From the top menu of the graphic display, press the **Enter** button.
2. Press the **Up** or **Down** button to scroll to the SYSTEM selection.
3. Press the **Enter** button. The first screen in the SYSTEM menu is displayed.
4. Press the **Up** or **Down** button to scroll through the three SYSTEM screens. You can press the **Enter** button on the Time screen to update its display.
5. Press the **Up** or **Down** button to scroll to the RETURN selection.
6. Press the **Enter** button to return to the Top Menu.

ACTIVITY Menu

The ACTIVITY menu allows you to scroll through current Acme Packet 6300/6350 System traffic statistics. These statistics provide a real-time snapshot of the capacity at which the system is operating.

The following information is displayed on the Acme Packet 6300/6350 System's ACTIVITY display in the order listed:

- Screen 1 — Number of sessions, sessions per minute, sessions per hour:

200 Sessions

40 Sessions/Minute

180 Sessions/Hour

- Screen 2 — Number of flows, flows per minute, flows per hour:
400 Flows

80 Flows/Minute

360 Flows/Hour

- Screen 3 — Number of used ports, number of free ports:

1000 Used Ports

2000 Free Ports

- Screen 4 — SNMP information: number of SNMP packets received, number of SNMP traps sent out:
SNMP:
PKTs in:20
TRAPs out:10
To exit the ACTIVITY menu in the graphic display:
 1. From the top menu of the graphic display, press the **Enter** button.
 2. Press the **Up** or **Down** button to scroll to the ACTIVITY selection.
 3. Press the **Enter** button. The first screen in the ACTIVITY menu is displayed.
 4. Press the **Up** or **Down** button to scroll through the three ACTIVITY screens. You can press the **Enter** button on any screen to update the display with the most recent statistics.
 5. Press the **Up** or **Down** button to scroll to the RETURN selection.
 6. Press the **Enter** button to return to the Top Menu.

ENVIRONMENT Menu

The ENVIRONMENT menu allows you to view information about the hardware's operational status. The graphic display presents the following information in the order listed:

- Screen 1 — Hardware alarms and link alarms:
HW ALARM: 0
LINK ALARM: 2
- Screen 2 — System temperature and fan speeds:
TEMPERATURE: 38.00 C
FAN SPEEDS:
100% 100% 100% 100% 100%100%100%100%100%100%100%100%100%
100%100%
- Screen 3 — System voltages:
VOLTAGES (V):
1.099, 1.186
1.488, 1.790
2.458, 3.278, 4.982
To exit the ENVIRONMENT menu in the graphic display:
 1. From the top menu of the graphic display, press the **Enter** button.
 2. Press the **Up** or **Down** buttons to scroll to the ENVIRONMENT selection.
 3. Press the **Enter** button. The ENVIRONMENT information is displayed.
 4. Press the **Up** or **Down** button to scroll to the RETURN selection.
 5. Press the **Enter** button to return to the Top Menu.

RETURN

Pressing the **Enter** button for the RETURN selection returns you to the base display during normal operating conditions or to the alarm display during an alarm condition.

Graphic Display Output for HA Nodes

The information included in this section only applies to high availability Acme Packet 6300/6350 System nodes. The graphic display on an Acme Packet 6300/6350 in an HA node indicates the current HA state. Five state indications can be displayed on the graphic display. Only the Standby and Active state indications appear in the graphic display for more than a few seconds. An explanation and example of each HA state follows.

Initial State Displays

The following example shows the output in the graphic display window of a Acme Packet 6300/6350 in the initial state:

```
NET - NET  
SESSION DIRECTOR (I)
```

Out Of Service State Displays

The following example shows the output in the graphic display window of an out-of-service Acme Packet 6300/6350:

```
NET - NET  
SESSION DIRECTOR (O/S)
```

Becoming Standby State Displays

The following example shows the output in the graphic display window of an Acme Packet 6300/6350 going into standby mode:

```
NET - NET  
SESSION DIRECTOR (B/S)
```

Standby State Displays

The following example shows the output in the graphic display window of a standby Acme Packet 6300/6350:

```
NET - NET  
SESSION DIRECTOR (S)
```

Active State Displays

Acme Packet 6300/6350 Systems in the active state use the default graphic display. The following example shows the display of an active Acme Packet 6300/6350:

NET - NET
SESSION DIRECTOR

4

System Installation

This chapter provides information about how to install the Acme Packet 6300/6350 and its associated components, includes cabling information.

Shipped Parts

Each Acme Packet 6300/6350 ships in one box. Inside this box is the Acme Packet 6300/6350 chassis and the accessory kit. The ordered Network Interface Unit (NIU) and power supplies are already installed in the chassis.

The following table lists the contents of one Acme Packet 6300/6350 order.

Table 4-1 Acme Packet 6300/6350 Shipping Contents

Location	Item
Main Shipping Box	Acme Packet 6300/6350 chassis
Accessory Kit	<ul style="list-style-type: none">• DB9 to RJ45 console adapter• AC or DC power cords• Grounding cable with lug• Slide extender kit for rack mounting

Installation Tools and Parts

The following tools and parts are required to install the Acme Packet 6300/6350 into your equipment rack:

- #2 Phillips-head screwdriver
- Rack and associated mounting hardware
- Shielded Ethernet CAT5e or CAT6 RJ45 cables
- 11/32" nut driver

Recommended Tools and Parts

Oracle recommends that you have the following parts on hand:

- Cable labels
- UPS for AC installations
- ESD wrist or heel straps
- ESD-safe location

Rack System Instructions

The following or similar rack-mount instructions are included with the installation instructions:

- **Elevated Operating Ambient** - If installed in a closed or multi-unit rack assembly, the operating temperature of the rack environment may be greater than the ambient room temperature. Therefore, consideration should be given to installing the equipment in an environment compatible with the maximum ambient temperature (T_{ma}) specified by the manufacturer.
- **Reduced Air Flow** - Installation of the equipment in a rack should be placed such that the amount of air flow required for safe operation of the equipment is not compromised.
- **Mechanical Loading** - Mounting of the equipment in the rack should be positioned such that a hazardous condition is not achieved due to uneven mechanical loading.
- **Circuit Overloading** - Consideration should be given to the connection of the equipment to the supply circuit and the effect that overloading of the circuits might have on overcurrent protection and supply wiring. Appropriate consideration of equipment nameplate ratings should be used when addressing this concern.
- **Reliable Earthing** - Reliable earthing of rack-mounted equipment should be maintained. Particular attention should be given to supply connections other than direct connections to the branch circuit (for example, use of power strips).

Pre installation



Note:

The Acme Packet 6300/6350 shall only be installed in a restricted access location.

The Acme Packet 6300/6350 must have access to reliable power and cooling. When choosing a location for your Acme Packet 6300/6350, follow the guidelines listed in this section.

Environmental Guidelines

When preparing to install your Acme Packet 6300/6350:

- Locate the Acme Packet 6300/6350 in a clean and well-ventilated room. This location should also be far from areas where heat, electrical noise, and electromagnetic fields are present.

Power Guidelines

When preparing to install your Acme Packet 6300/6350:

- Ensure that the installation location has access to adequate power and grounding. Separate circuits should be available for each of the two Acme Packet 6300/6350 power supplies.
- The Acme Packet 6300/6350 may only be powered by AC or DC circuits at one time; mixed power supply configurations are unsupported.
- Never use extension cords when powering an Acme Packet 6300/6350.

- Use grounded, 3-conductor circuits.
- A local earth ground must be available.
- For DC, the installation must provide over current rated at 35A.
- A service disconnect must be provided for each power supply that is clearly marked and is nearby the equipment.

 **Note:**

Connect each of the Acme Packet 6300/6350 power supplies to a separate circuit. If both supplies are connected to outlets on the same circuit, the Acme Packet 6300/6350 will lose power to both supplies if that circuit loses power. In that case, the whole Acme Packet 6300/6350 would lose power.

Mounting Guidelines

When preparing to install your Acme Packet 6300/6350, please follow these guidelines:

- Leave enough clearance (approximately 8" (20 cm)) in front of the equipment rack for sufficient air flow and to allow access to the reset button and graphic display buttons.
- Leave enough clearance (approximately 8" (20 cm)) in the rear of the equipment rack to allow for sufficient airflow and for ease in cabling and/or servicing the rear panel.
- Do not block the air inlets or the fan module, or obstruct airflow to the system in any way.
- Position equipment to allow for serviceability. This will aid in chassis removal, and prevent the need to remove or loosen other equipment in the rack.
- Remember that the Ethernet interfaces are limited to 328 feet/ 100 meters as defined by the FAST Ethernet standard, IEEE 802.3.
- Use the contents of the Slide extender kit for cabinet-style, 4-post equipment racks that range in depth from 28-32 inches.

Other Safety Guidelines

When preparing to install your Acme Packet 6300/6350:

- Ensure that the equipment rack is securely bolted to the floor, and that the equipment rack and components are properly grounded.
- For AC power installations, use a regulating UPS to protect the Acme Packet 6300/6350 from power surges, voltage spikes, and power failures.
- For AC power installations, ensure that your UPS can supply power for enough time to save your system data and shut down the system gracefully.

Mounting Installation

Overview

This section explains how to unpack and install your Acme Packet 6300/6350 in a telecommunications or server equipment rack. The Acme Packet 6300/6350 standard

mounting hardware is used for installation in a 4-post, 19-inch cabinet-style equipment rack. Mounting hardware for a 23" equipment rack is available by special order.

Mounting Options

The Acme Packet 6300/6350 ships with hardware for mounting in 4-post tapped-hole equipment rack or square-hole equipment rack. The Acme Packet 6300/6350 also ships with hardware for mounting in a 2-post center-mount equipment rack. This section explains the procedures for each mounting option.

Note:

Failure to follow the instructions outlined in this section might compromise the Acme Packet 6300/6350 proper functioning. To prevent personal injury, we recommend that two people lift and install the chassis into the equipment rack.

Unpacking the Acme Packet 6300/6350

To unpack the Acme Packet 6300/6350:

1. Inspect the external packing materials and note if they are damaged in any way.
2. Open the exterior box.
3. Unpack the contents of the Acme Packet 6300/6350 shipment.
4. Locate the packing list that comes with the Acme Packet 6300/6350 shipment; the packing list is located outside of the shipment box.
5. Confirm that all of the components listed in the shipping box contents are present and in good condition.

If you discover that any of the parts are missing or were damaged in shipment, contact Oracle to request assistance.

Cabinet-Style 4-Post Chassis Installation

The following sections explain how to mount your Acme Packet 6300/6350 in a cabinet-style, 4-post equipment rack.

Mounting System

Acme Packet provides flexible mounting options for your equipment rack installation.

Stationary slides are mounted on each side of the equipment rack. Complimentary chassis slides are mounted on each side of the Acme Packet 6300/6350. Once the equipment rack and Acme Packet 6300/6350 hardware is in place, insert the chassis, on its slides into the equipment rack mounted slides. When the Acme Packet 6300/6350 is fully inserted into the equipment rack, it is secured in place with two thumbscrews and 4 rack screws.

Installing the Stationary Slides

In this first stage of system installation, you secure the stationary slide to the equipment rack. The end with three mounting slots on the stationary slide rail is attached to the front of the equipment rack and the bare steel side is attached to the rear of the equipment rack. The stationary slide rail can expand and contract to accommodate equipment racks of various depths.

You can mount the stationary slide rail to both tapped hole rack slide rails and square rack slide rails. Follow the appropriate procedure below.

Tapped Hole Rack Installation

This section explains how to mount the Acme Packet 6300/6350 mounting slide rail assembly in a tapped hole equipment rack.

Front-Mounting a Tapped Hole Rack Installation

To install the stationary slide rails on the front of a tapped hole equipment rack:

1. Locate the following components:
 - 2 x stationary slide rail sections
 - 4 x 10-32 x 5/8" screws
 - 2 x mounting spacers
2. Line up the stationary slide rail end with three mounting slots with an appropriate mount point on the front of the equipment rack.

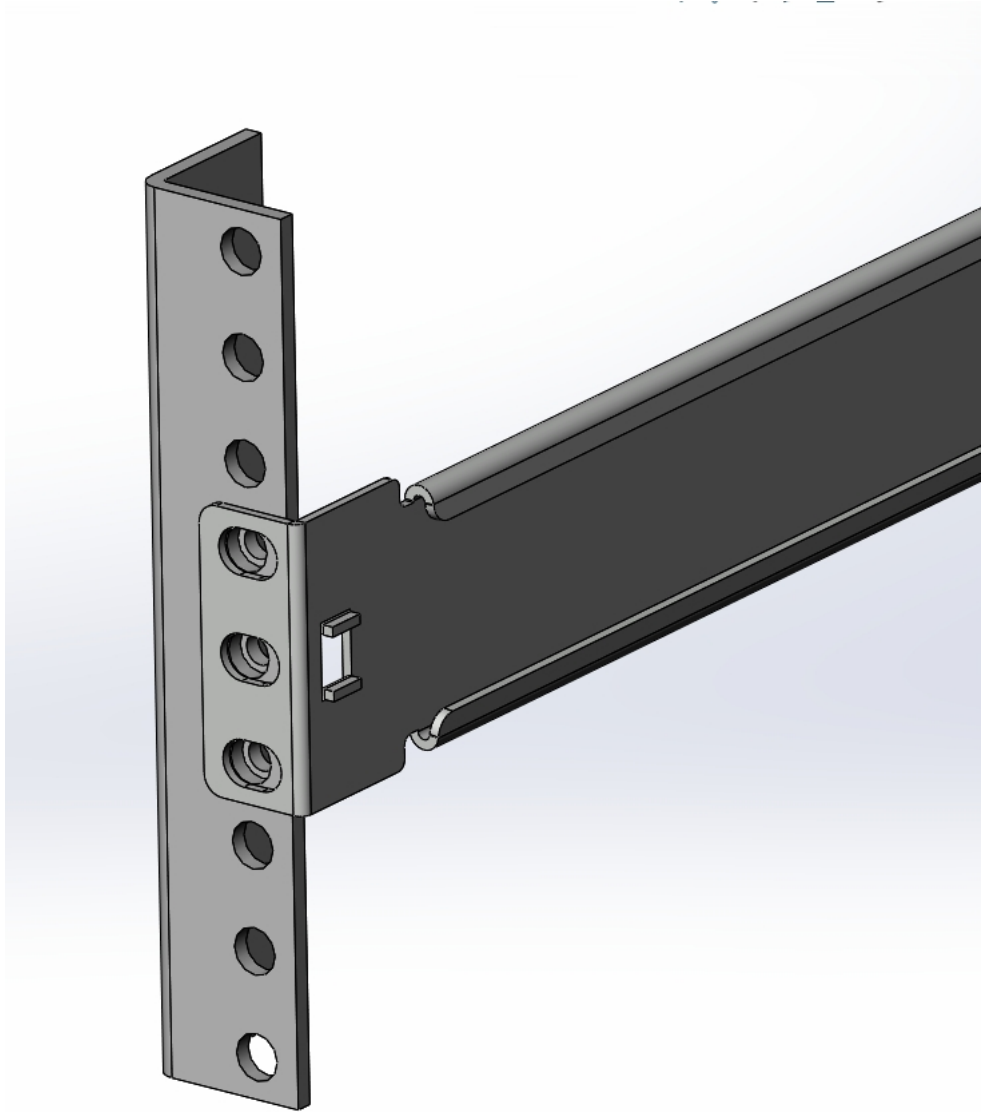

Stationary Slide Rail Lined Up With Front Mount Point

3. Place 2 x 10-32 screws through the mounting spacer and through the stationary slide rail ear.
4. Screw in and secure the stationary slide rail to the equipment rack as shown in the following exploded view. Do not completely torque the screws; leave a small amount of play at this point.

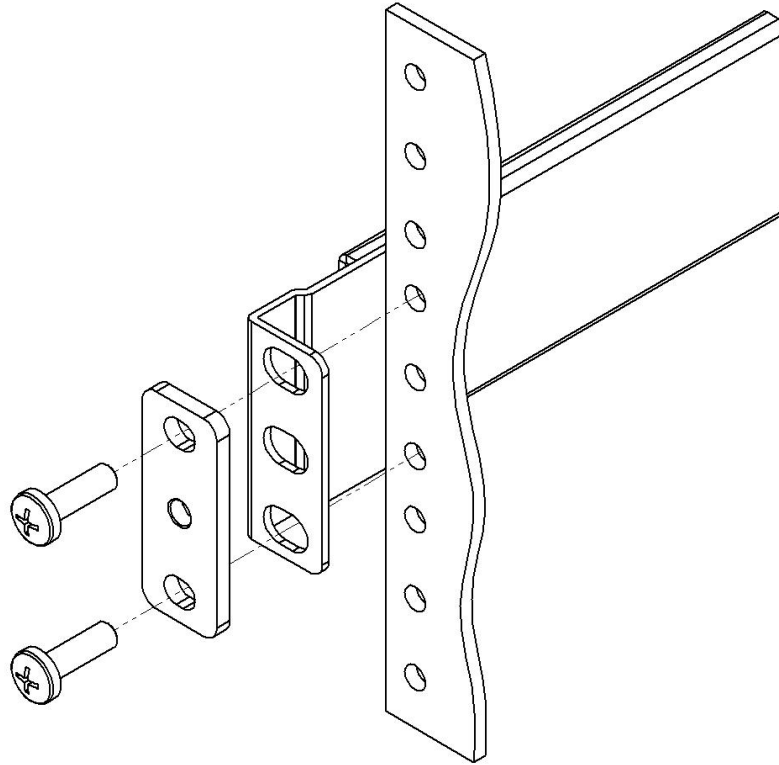

Screwing In and Securing the Stationary Slide Rail

5. Repeat Steps 3 and 4 for the other mounting point.

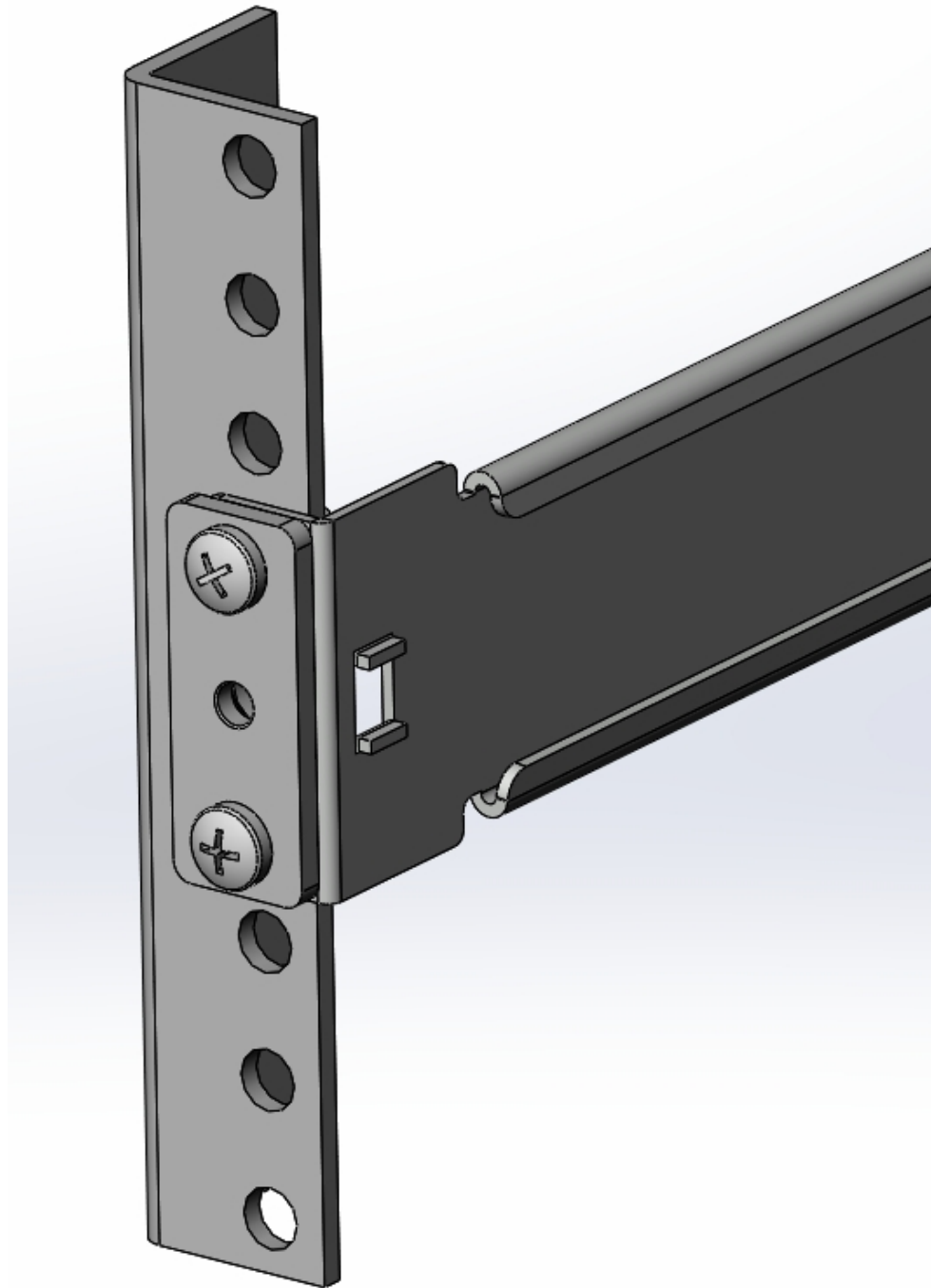

Installed Stationary Slide Rail

6. Repeat this procedure for the other stationary slide. Your rack should resemble the following image.

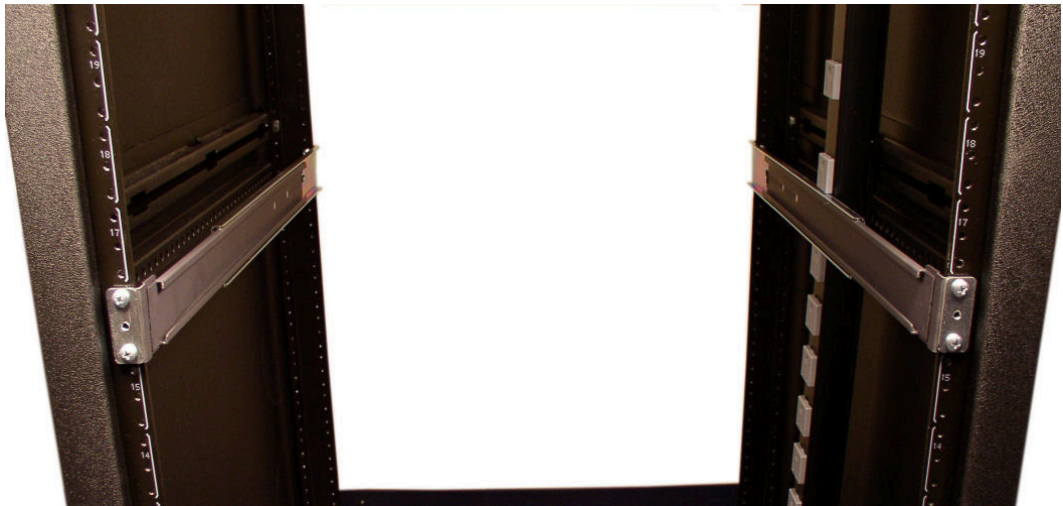

Installed Stationary Slide Rails

Rear-Mounting a Tapped Hole Rack Installation

To install the stationary slide rails on the rear of a tapped hole equipment rack:

1. Locate the following components:
 - 4 x 10-32 x 5/8" screws
2. Expand and line up the opposite end of the stationary slide rail on the outside of the rear rack slide rail at the same height used for the front mount point.



Rear Mount Point

3. Place one 10-32 screw through the stationary slide rail ear and screw in place.
4. Repeat Step 3 for the other mounting point.

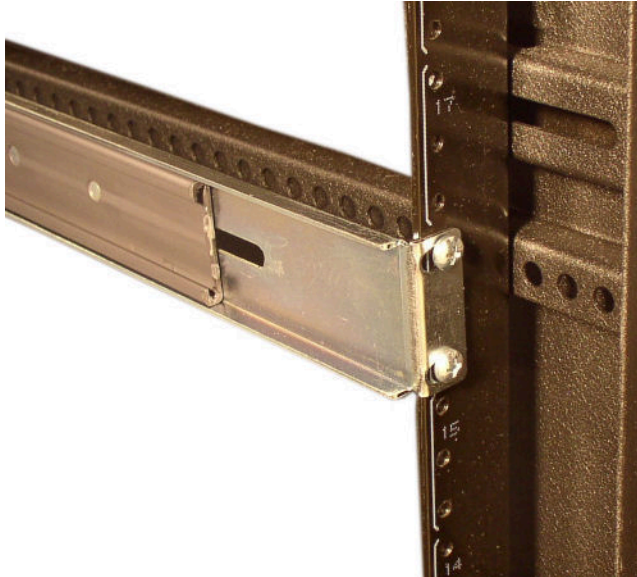

Stationary Slide Rail Secured to Rear Mount Point

5. Your rack should resemble the following image.

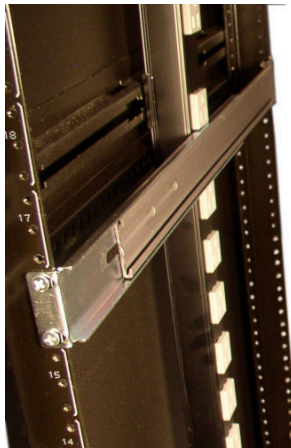

Rear-Mounted Stationary Slide Rails

Square Hole Rack Installation

This section explains how to mount the Acme Packet 6300/6350's mounting slide rail assembly in a square hole equipment rack. You can use 10-32 cage nuts as an alternative to the provided nut bars, but they must be mounted prior to this procedure.

Front-Mounting a Square Hole Rack Installation

To install the stationary slide rails on the front of a square hole equipment rack:

1. Locate the following components:
 - 2 x stationary slide rail sections
 - 4 x 10-32 x 5/8" screws
 - 2 x mounting spacers

- 2 x nut bars
2. Line up the stationary slide rail end with three mounting slots with an appropriate mount point on the front of the equipment rack.

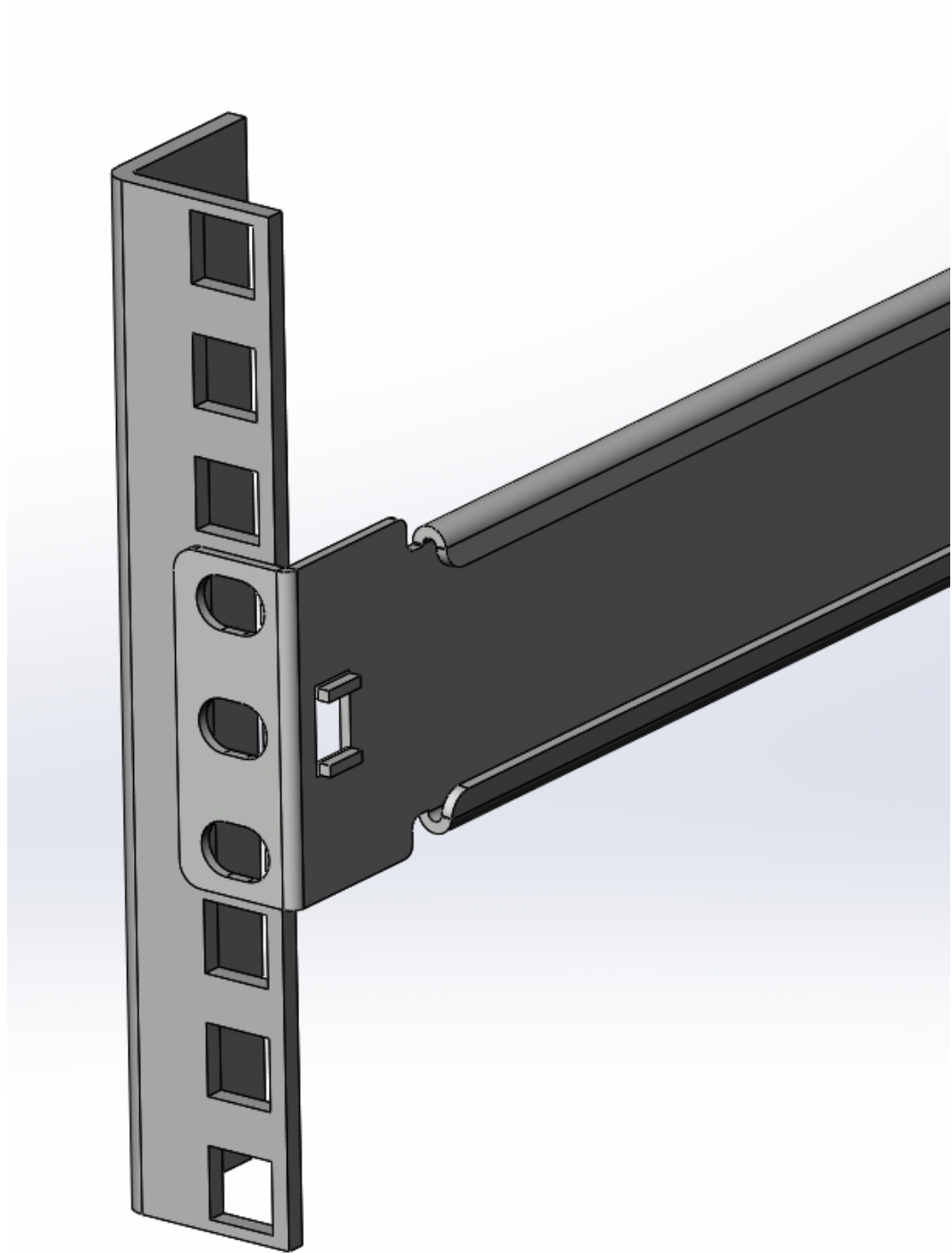

Front Mount Point

3. Place 2 x 10-32 screws through the mounting spacer, through the stationary slide rail ear, through the square rack slide rail.

4. Hold the nut bar behind the front rack slide rail.
5. Secure the 10-32 screw to the nut bar you are holding in place. Refer to the following exploded view of procedure:

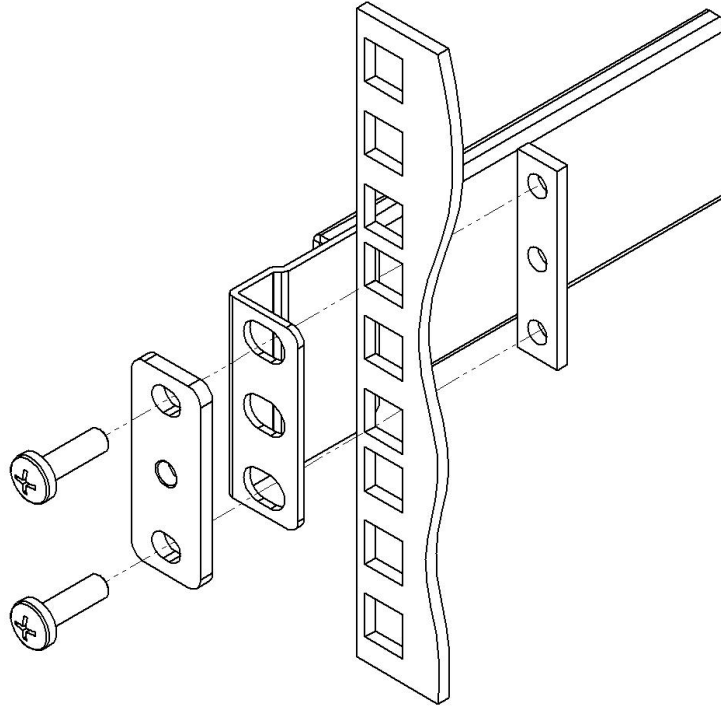

Screwing In and Securing the Stationary Slide Rail

Do not completely torque the screws; leave a small amount of play at this point.

6. Repeat Steps 3 - 5 for the other mounting point.

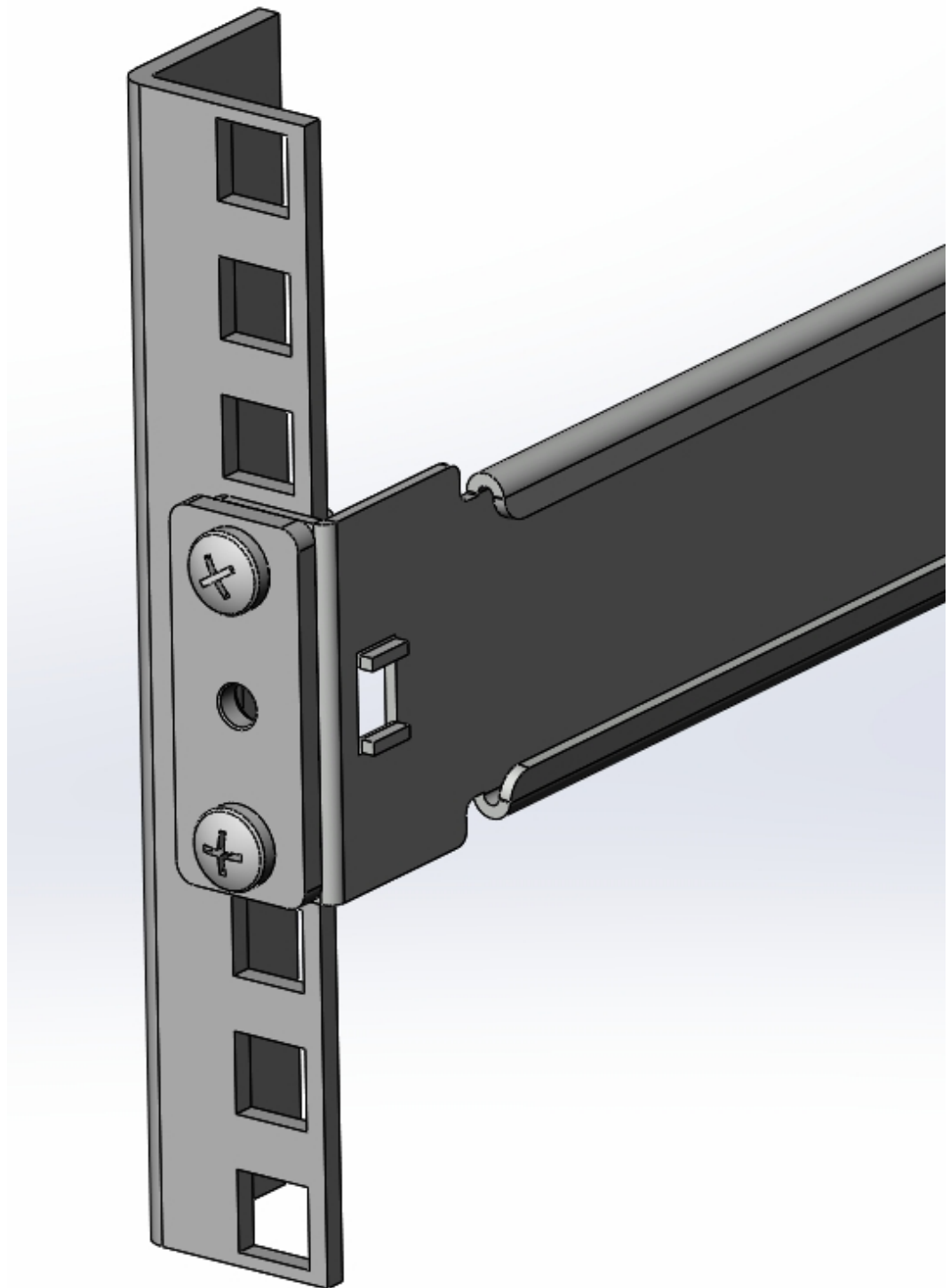

Stationary Slide Rail Secured to Front Mount Point

7. Repeat this procedure for the other stationary slide.

Rear-Mounting a Square Hole Rack Installation

To install the stationary slide rails on the rear of a square hole equipment rack:

1. Locate the following components:
 - 4 x 10-32 x 5/8" screws
 - 2 x nut bar
2. Expand and line up the stationary slide rail end with three mounting slots on the outside of the rear rack slide rail at the height used for the front mount point.

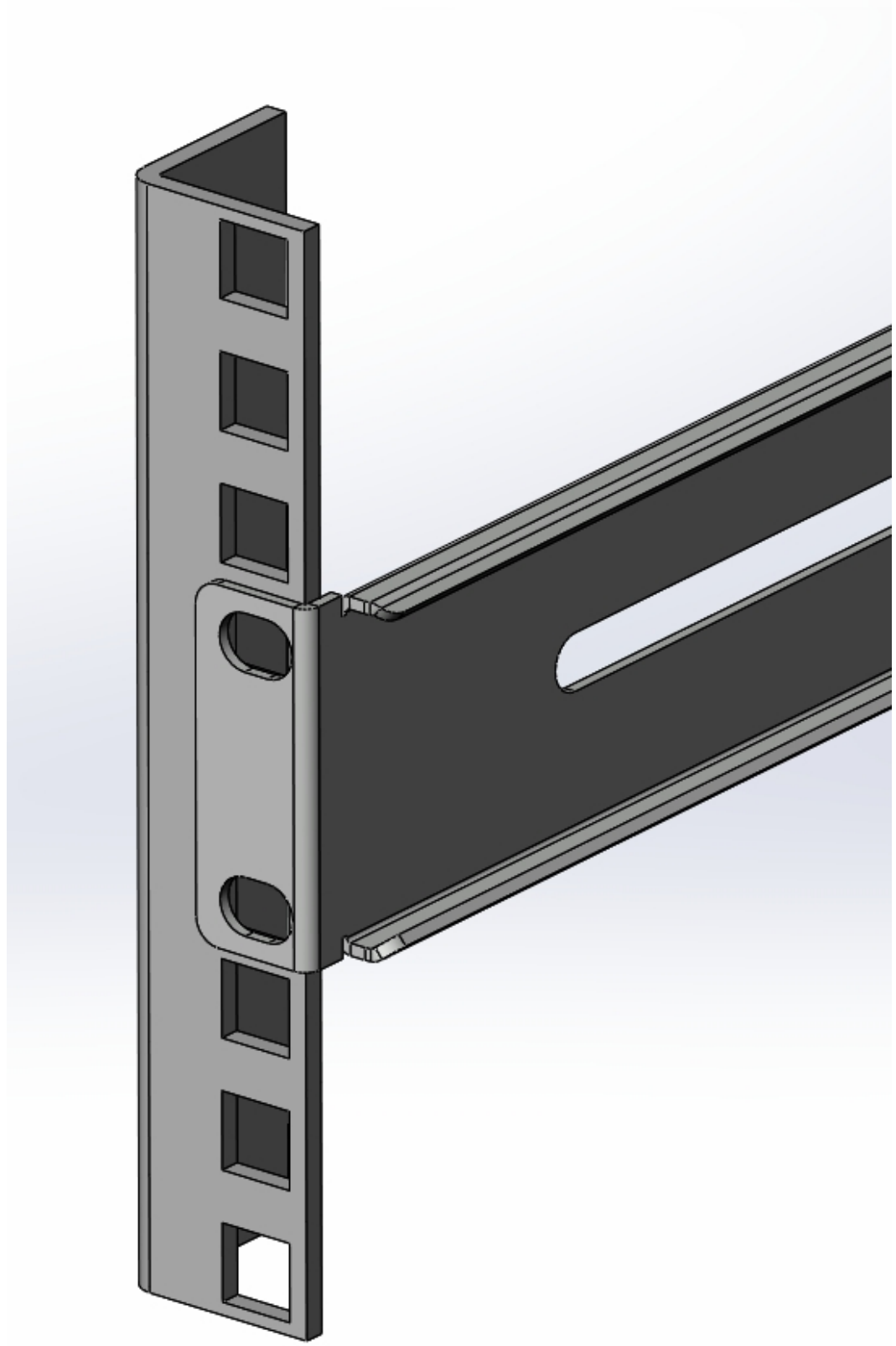

Rear Mount Point

3. Hold the nut bar behind the rear rack slide rail.

4. Place 2 x 10-32 screws through the stationary slide rail ear and screw in place.
5. Repeat Steps 3 and 4 for the other mounting point.

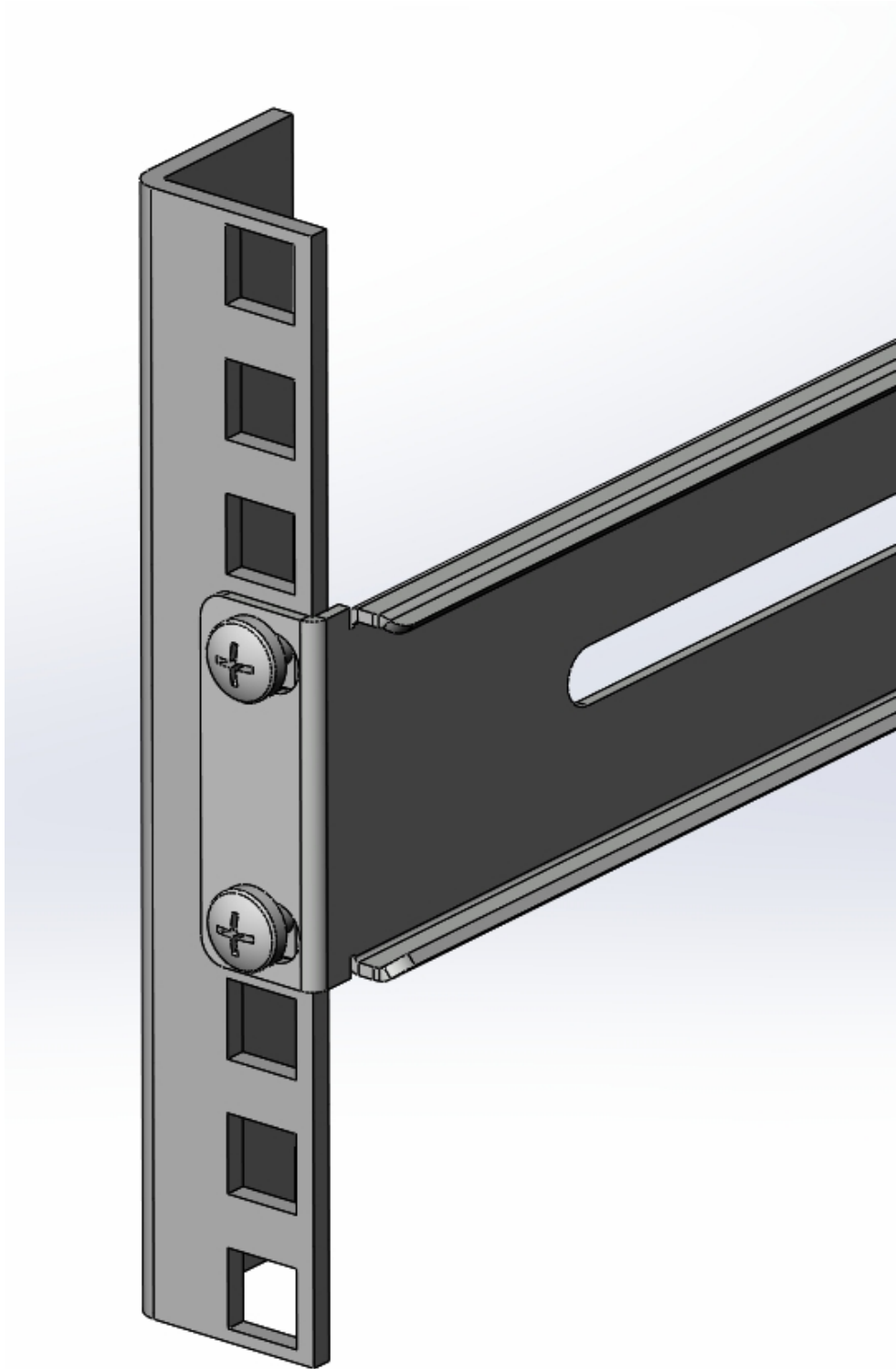

Stationary Slide Rail Secured to Rear Mount Point

6. Repeat this procedure for the rear of the other stationary slide.

Installing the Chassis Ears and Slides

In this second portion of system installation, two chassis ears and two chassis slides are secured to the Acme Packet 6300/6350.

To install the chassis slide rails on the Acme Packet 6300/6350:

1. Locate the following components:
 - 6 x 10-32 x 5/16" flat head (black) screws
 - 2 x front mounting ears (left and right)
 - 6 x 6-32 x 5/16" screws
 - 2 x chassis slides
2. Line up one chassis ear with the tapped holes as shown in the following image. Position the chassis ear's spring-loaded thumbscrew toward the front panel of the system.



Chassis Ear Mount Points

3. Use 3 x 10-32 x 5/16" Flat head screws to secure the chassis ear to the chassis. Final installation resembles the image below.



Chassis Ear Installed

4. Line up the chassis slide with the Acme Packet 6300/6350 side panel. Position the slide's large marker hole at the front of the Acme Packet 6300/6350 chassis. The remaining three tapped holes will line up with the slide's holes. The following image points out the tapped holes.

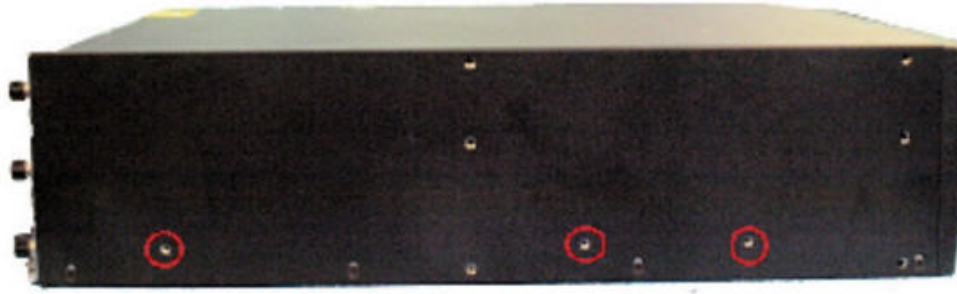

Chassis Slide Rail Mount Points

5. Use 3 x 6-32 x 5/16" screws to secure the chassis slide rail to the chassis. Notice that the large hole in the slide rail is positioned toward the front of the Acme Packet 6300/6350.

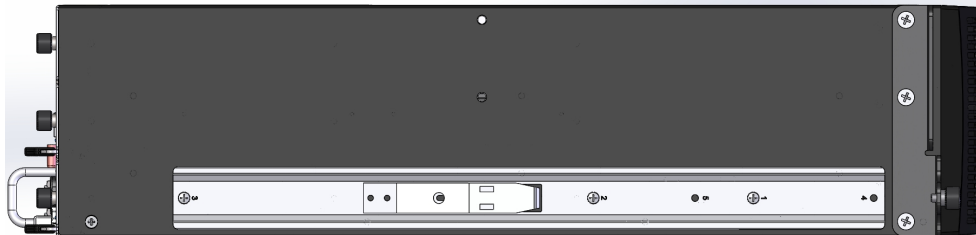

Chassis Slide Rail Installed

6. Repeat steps 2-5 for the other side of the Acme Packet 6300/6350.

Installing the Chassis in the Rack

You now lift the Acme Packet 6300/6350 and install it into the rack. To prevent personal injury or damage to the Acme Packet 6300/6350 follow these guidelines:

- This installation requires two people and should not be attempted otherwise.
- Follow your organization's best practices for lifting and installing heavy components into an equipment rack.
- Ensure that the Acme Packet 6300/6350 remains supported until you have completely installed it into the equipment rack.
To install the Acme Packet 6300/6350 in the equipment rack:
 1. Lift the Acme Packet 6300/6350 into the correct position in the equipment rack.
 2. Insert the chassis slides into the stationary slides.



Stationary Slide Rails Mounted to Rack

3. Depress the safety release latch points halfway down the slide and push the Acme Packet 6300/6350 fully into the equipment rack.

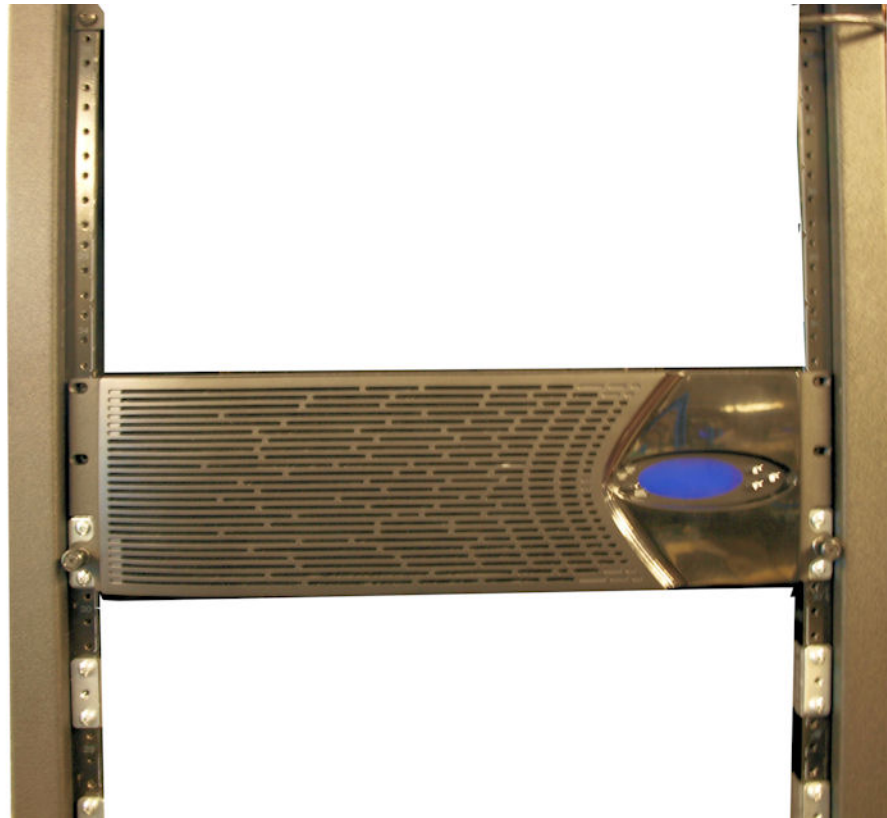

Acme Packet 6300/6350 Installed in Equipment Rack

4. Line up the chassis-mounted thumbscrews with the threads on the mounting spacer. You may have to adjust the spacer locations before they line up with the Acme Packet 6300/6350 captive screws.
5. Once correctly positioned, screw the thumbscrews into the mounting spacer and secure the chassis in the rack.

6. Fully tighten all 4, 10-32 x 5/8" front screws that hold the stationary slide rails to the rack.

Center-Mount 2-Post Chassis Installation

The following sections explain how to mount your Acme Packet 6300/6350 in a center-mount, 2-post equipment rack.

Installing the Center-Mount Hardware

Center mounting ears are attached to each side of the Acme Packet 6300/6350. These mounting ears are reversible, and are not mated to a specific side of the chassis. While the Acme Packet 6300/6350 is shipped with all mounting hardware for attaching the rack ears to the chassis, you must obtain and use the appropriate hardware recommended by the equipment rack's manufacturer for mounting the system in the rack.

To install your Acme Packet 6300/6350 in a center-mount configuration:

1. Locate the following components:
 - 2 x center-mounting ears
 - 6 x 10-32 x 5/16" flat head (black) screws
2. Line up one chassis ear with the tapped holes as shown in the following image.

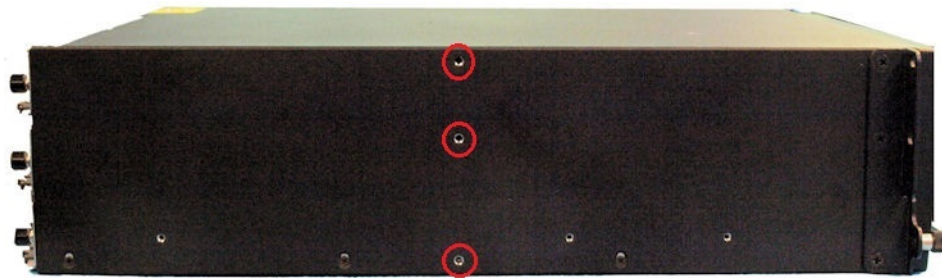

Chassis Ear Mount Point

3. Use 3 x 10-32 x 5/16" flat head (black) screws to secure the 19-inch mounting ear to the chassis. The image below shows the installed mounting ear.



Center Mounted Chassis Ear Installed

4. Repeat this procedure for the mounting ear on the other side of the Acme Packet 6300/6350.

Installing the Chassis in the Rack

The Acme Packet 6300/6350 is now ready to be installed into the center mount rack. To prevent personal injury or damage to the chassis, please follow these guidelines:

- This installation requires two people and should not be attempted otherwise.
 - Follow your organization's best practices for lifting and installing heavy components into an equipment rack.
 - Ensure that the Acme Packet 6300/6350 remains supported until you have completely installed it into the equipment rack.
1. Locate the following components:
 - 4 x equipment rack screws

 **Note:**

You may use the #10-32 x 5/8 screws included with the Acme Packet 6300/6350 or you may use your own.

2. Lift the Acme Packet 6300/6350 into the correct position in the equipment rack.
3. Screw the mounting ears on the Acme Packet 6300/6350 into the equipment rack using four rack screws. One person should hold the Acme Packet 6300/6350 in the correct position, and another person should screw the Acme Packet 6300/6350 in place.



Center-Mounted Acme Packet 6300/6350

Fan Module Installation

The fans are pre-installed in the Acme Packet 6300/6350 when shipped. It is unnecessary to remove a fan prior to installation. In case the fan needs service or replacement, you can remove and replace it with a functioning one. Contact your salesperson for order information.

Ground and Power Cable Installation

The Acme Packet 6300/6350 must be properly grounded to ensure efficient system performance. Grounding your Acme Packet chassis is an extremely important part of the installation and maintenance procedures. If the Acme Packet 6300/6350 is not properly grounded, it can result in physical harm, problems with system functionality, and it can exhibit the following unpredictable problems:

- Garbled output on the console display
- Sudden crashes
- Physical damage to the Acme Packet chassis and its hardware components

Note:

Failure to ground the chassis properly can result in bodily harm (in certain circumstances) and permanent damage to the Acme Packet 6300/6350 and its components. The Acme Packet 6300/6350 does not support mixing AC and DC power supplies in the same chassis. A mixed power configuration is prohibited.

Your equipment rack location must have a local earth ground. This ground can be either an unpainted spot on the grounded equipment rack frame or a grounded bus bar in the equipment room.

Grounding Cable Installation

The ground terminals are located to the left of the two power supplies, in the rear of the chassis. The Acme Packet 6300/6350 ships with 2 keps nuts screwed onto the ground terminals. You use an 11/32" nut driver to remove and install these keps nuts.

This section shows you how to install the grounding cable on your Acme Packet 6300/6350.

Important: Acme Packet 6300/6350 equipment is suitable for installation as part of a Common Bonding Network (CBN).

 **Note:**

The Common Bonding Network (CBN) is a term used for the connection of building steel, water pipes, cable racks, vertical and horizontal equalizer conductors, bonding conductors and electrical metallic raceways within a building, when they are bonded together by either deliberate or incidental connections. The CBN is also connected to the building's grounding electrode system. Connections to the CBN are usually made from equipment frames to reduce voltage differences to acceptable levels when current flows through these frames, either during fault occurrences in the AC or DC power systems, or when lightning strikes. To install the grounding cable on the Acme Packet 6300/6350:

1. Unscrew and remove the two keps nuts from the grounding posts located on the rear of the Acme Packet 6300/6350. Place them aside.

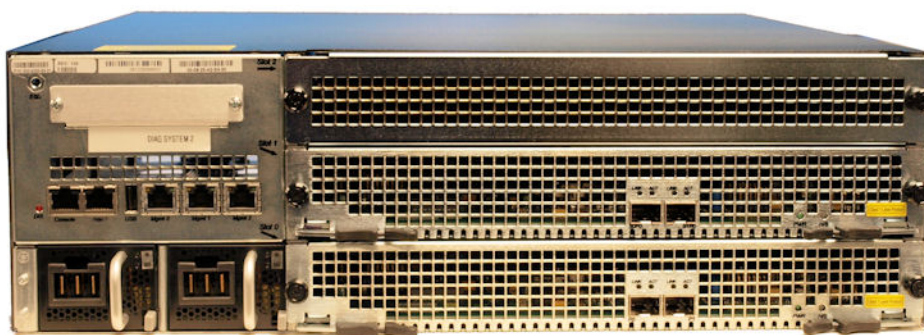

Grounding Posts

2. Place the lug on the end of the grounding cable onto the grounding posts in the orientation shown in the following image.



Installing the Ground Cable Lug Onto the Grounding Posts

3. Screw the two keps nuts onto the grounding post, securing the grounding lug in place. When attached correctly, the grounding lug fits snugly between the chassis's rear panel and the keps nuts. Connect the other end of the grounding wire to a suitable grounding point at your site.

 **Note:**

Always make the ground connection first and disconnect it last when installing or removing the system from an equipment rack.

AC Power Cord Installation

This section describes how to install an AC power cord.

 **Note:**

Use a 15 Amp fused circuit for each AC power supply.
Important: This equipment is intended for installation in locations where National Electrical Code (NEC) applies.

To install the two AC powers cords in the Acme Packet 6300/6350:

1. Locate the two AC power cords shipped with your Acme Packet 6300/6350. Choose one power supply to work on first.
2. Connect one power cord to the AC power supply by inserting the 3-lead IEC-320 plug into the IEC connector located on the power supply.



Acme Packet 6300/6350 Power Supplies

3. Connect the other power cord to the AC power supply by inserting the 3-lead IEC-320 plug into the IEC connector located on the power supply.
4. Route the AC power cords through your rack and cabling system to the power outlets.
5. Plug the supply end of each power cord into its own circuit.
6. There is no ON/OFF switch on these power supplies. When you plug them in the power is on and the system will start to boot.

 **Note:**

To remove AC power cables from the Acme Packet 6300/6350 reverse the previous procedure.

DC Power Cord Installation

This section describes how to install a DC power cord.

Important: This equipment is intended for installation in Network Telecommunication Facilities.



Note:

Use a 35 Amp min fused circuit for each DC power supply.
To install the DC power cords in the Acme Packet 6300/6350 System:

1. Locate the two DC power cords shipped with your Acme Packet 6300/6350. Choose one power supply to work on first.
2. Connect one power cord to the power supply by inserting the 3 position connector into the input connector located on the power supply.

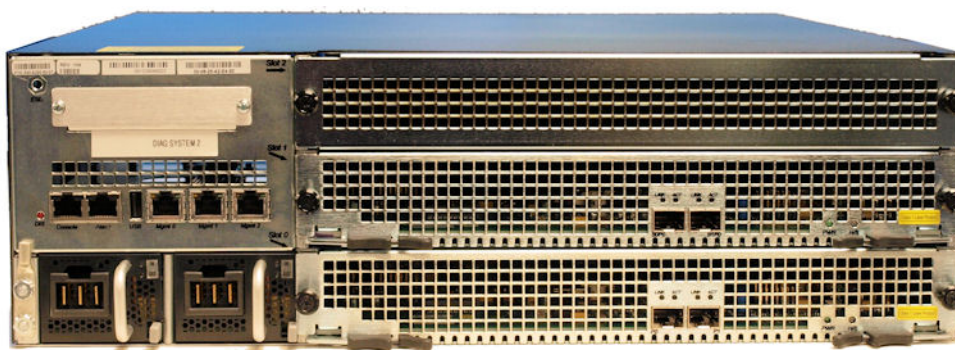

Acme Packet 6300/6350 DC Power Supplies

3. Connect the other power cord to the power supply by inserting the three-position connector into the input connector located on the power supply.
4. Route the DC power cords through your rack and cabling system to the power outlets.
5. Plug the power supply end of each power cord into its own circuit.
6. There is no ON/OFF switch on these power supplies. When you plug them in the power is on and the system will start to boot.
7. To remove DC power cables from the Acme Packet 6300/6350, reverse the previous procedure.

Cabling the Acme Packet 6300/6350 System

After mounting the Acme Packet 6300/6350 in an equipment rack and installing all components into the chassis, connect all appropriate data cables to the ports before powering up and configuring the system.

Acme Packet recommends using fully shielded CAT5e or CAT6 Ethernet cables for Network Interface Unit (NIU) media and management Ethernet connections to protect the Acme Packet 6300/6350 System from potential damage.

You can install and remove Ethernet and 10GbE optical cables while the Acme Packet 6300/6350 System is operational. Not every port needs to be utilized for proper operation. However, when a cable is disconnected and the link is lost, an alarm is generated.

 **Note:**

The intra-building ports of the equipment are suitable for connection to intra-building or unexposed wiring or cabling only. The intra-building ports of the equipment must not be metalically connected to interfaces that connect to the Outside Plant (OSP) or its wiring. These interfaces are designed for use as intra-building interfaces only (Type 2 or Type 4 ports, as described in GR-1089–CORE, Issue 6) and requires isolation from the exposed OSP cabling. The addition of primary protectors is not sufficient protection to connect these interfaces metalically to OSP wiring. Intra-building ports include Media and Signaling Network Interfaces, Network Management Ports, Alarm Ports, and Console Port.

Console Port

The Acme Packet 6300/6350 has one console port in the rear left side of the chassis. The Acme Packet 6300/6350 ships with a console adapter, which allows you to connect a standard DB-9 serial port to the RJ45 console port.



Console Port

Chassis Console Cabling Procedure

This section explains how to create a serial connection to the Acme Packet 6300/6350 console port. Use the rear left side of the chassis console port for permanent connections to a terminal server or other serial device.

To connect a console cable to the rear left side of the chassis console port:

1. Locate a shielded CAT5e or CAT6 console cable to connect it to the Acme Packet 6300/6350.

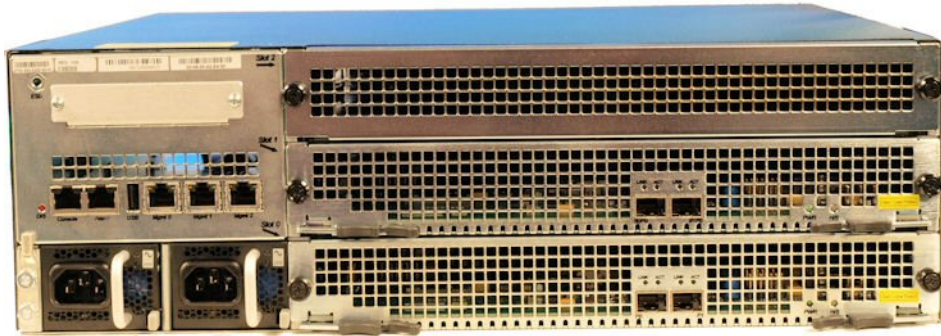

Console Port

2. Insert the RJ45 connector on the end of the console cable into the console port labeled Console.

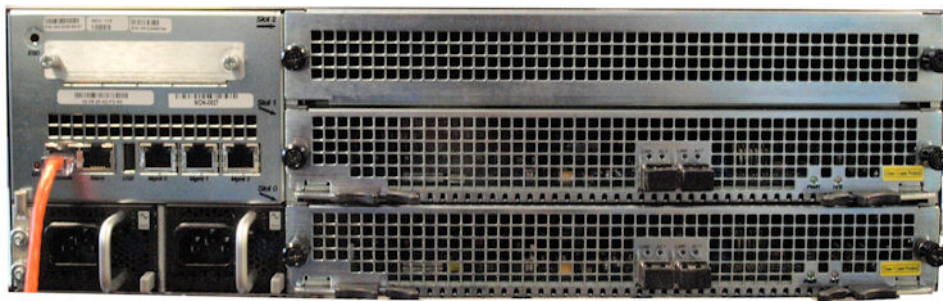

Connected Console Port Cable

3. Lead the console cable neatly away from the rear panel toward a terminal server or other component where this serial connection terminates.

Alarm Port Cabling

The alarm port indicates electrically when an alarm has been generated on the Acme Packet 6300/6350. The alarm port contains leads for three circuits, each of which closes to signify a corresponding alarm.

Cabling Procedure

To connect the alarm port cable to the NIU alarm port:

1. Locate the alarm contact cable you plan to connect to the Acme Packet 6300/6350 System.
2. Insert the RJ45 connector on the end of the alarm port cable into the alarm port labeled Alarm. The release tab on the RJ45 jack clicks into place when you insert it properly.

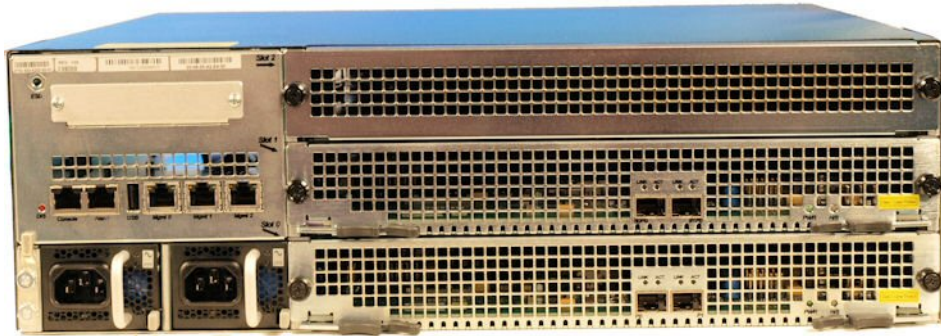

Alarm Port

Lead the alarm cable neatly away from the rear panel toward any alarm monitoring equipment. The following figure shows a Acme Packet 6300/6350 with an alarm cable properly connected.



Connected Alarm Port Cable

Network Management Ports

Standard shielded CAT5e or CAT6 (or higher) Ethernet cables with RJ45 jacks are used for connecting the Acme Packet 6300/6350 management Ethernet ports to your network. These ports support 10/100/1000 Mbps speeds.

Note:

Keep Ethernet cables separated from power cables by at least 60mm where possible and never run them in the same channel of a trunking system without segregation.

Cabling Procedure

To connect Ethernet cables to the rear panel Ethernet ports:

1. Locate the Ethernet cables you plan to connect to the Acme Packet 6300/6350.
2. Insert the RJ45 connector on the end of the Ethernet cable into one of the NIU management Ethernet ports. These ports are labeled Mgmt0, Mgmt1, and Mgmt2. The release tab on the RJ45 jack will click into place when you insert it properly.



Network Management Ethernet Ports

3. Route the cable away from the Acme Packet 6300/6350. Make sure that the Ethernet cables are not stretched tightly or subject to extreme stress.

Acme Packet 6300/6350 with a network management cable connected and inserted in Mgmt0.

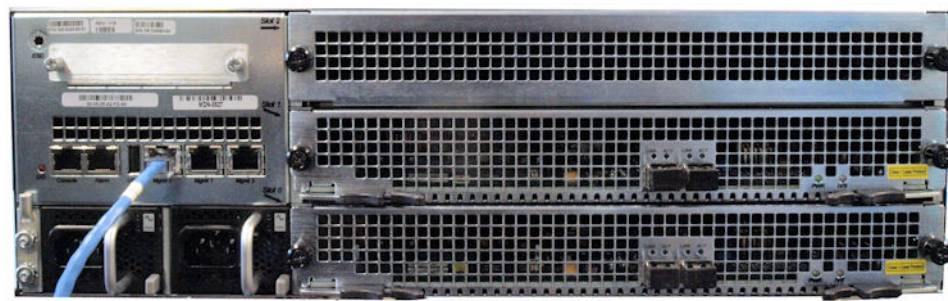

Connected Network Management Port Cable

4. Repeat Steps 1 through 2 for each additional management Ethernet cable you will connect to your Acme Packet 6300/6350.

Media and Signaling Network Interfaces

This section explains how to connect a cable for media and signaling. The NIU is available with optical SFP+ Ethernet connectors.

Note:

Perform all cabling procedures according to the established standards for your organization.

10GbE SFP+ Optical Cabling Procedure

This section explains how to cable the Acme Packet 6300/6350 configured with 10GbE optical NIUs. Either 10-gigabit single mode or multimode fiber optic cabling with duplex LC connectors are used to connect the Acme Packet 6300/6350 SFP+ based NIUs to your network.

Fiber Optic Cable Handling

When handling a fiber optic cable, please take these precautions:

- Never touch the polished end of the fiber cable.
- To prevent serious eye damage, never look directly into a fiber optic cable connector or mating adapter.
- Clean all fiber optics before installing them into your network according to prescribed procedures.
- Ensure that the bend radius of your fiber cables is kept to a minimum of 3" or that specified by the fiber cable manufacturer.
- Perform all cabling procedures according to the established standards for your organization.

Connecting to the Physical Interface Cards

To connect network 10GbE optical cabling to the 10GbE optical physical interface cards:

1. Locate the 10GbE fiber optic cables you plan to connect to the Acme Packet 6300/6350.
2. Insert the duplex LC connector on the end of the fiber cable into one of the SFP+ optical transceivers. The connector should click and lock in place when you insert it properly. The media and signaling ports (from left to right, bottom to top) are labeled: P0 & P1 on each NIU. The image below shows Multi Mode cable.



SFP+ Ports

3. Route the cable away from the Acme Packet 6300/6350. Make sure that the fiber optic cables are not stretched tightly or subjected to extreme stress. The image below shows an Acme Packet 6300/6350 with media network cables properly connected and inserted into ports P0 & P1. The image below shows Single Mode cable.
4. Repeat Steps 1 through 2 for each additional fiber optic cable you connect to your Acme Packet 6300/6350.

Cabling for HA Deployments

The information and instructions in this section explain how to cable an HA node.

HA Cabling

Category 5 (or higher) shielded Ethernet cables are required for cabling two HA nodes together.

Rear Panel Cabling

You can use one or two connections for HA redundancy support between the two members of an HA node. Using two rear interfaces for sharing redundancy information provides a high level of reliability. As a rule, Mgmt0 should be reserved as the boot/maintenance interface. This leaves Mgmt1 and Mgmt2 available for sharing HA information.



HA-Sharing Ports

Management network ports feature automatic crossover negotiation so that a crossover cable is not necessary for HA cabling.

To cable Acme Packet 6300/6350 in an HA configuration using single rear interface support:

1. Insert one end of an Ethernet cable into either Mgmt1 or Mgmt2 on the rear panel of the SBC1. The release tab on the RJ45 jack clicks into place when you insert it properly.
2. Insert the other end of the Ethernet cable into the corresponding management interface on the rear panel of SBC2. The release tab on the RJ45 jack clicks into place when you insert it properly. If you use Mgmt1 on SBC2, then you will connect it to Mgmt1 on SBC2.

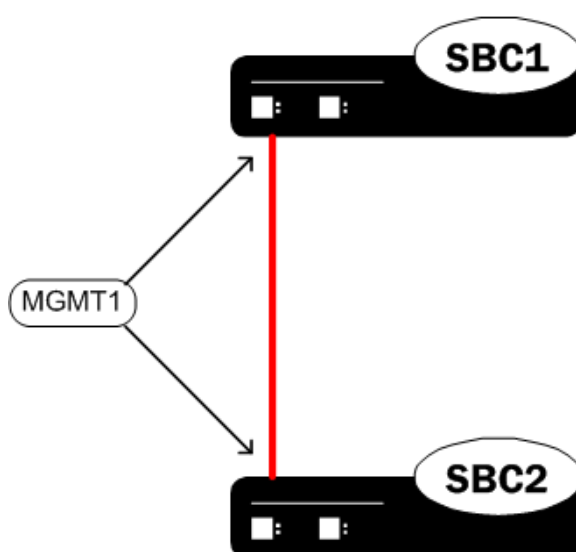

Mgmt1 Connections on SBC1 and SBC2

3. Refer to the configuration procedures located in the HA Nodes chapter of the Acme Packet Configuration Guide.

To cable the Acme Packet 6300/6350 in an HA configuration using dual rear interface support:

4. Insert one end of an Ethernet cable into Mgmt1 on the rear panel of SBC1. The release tab on the RJ45 jack clicks into place when you insert it properly.
5. Insert the other end of the cable into the Mgmt1 port on the rear panel of SBC2. The release tab on the RJ45 jack clicks into place when you insert it properly.
6. Insert one end of a second Ethernet cable into Mgmt2 on the rear panel of SBC1. The release tab on the RJ45 jack clicks into place when you insert it properly.
7. Insert the other end of the cable into Mgmt2 on the rear panel of SBC2. The release tab on the RJ45 jack clicks into place when you insert it properly.

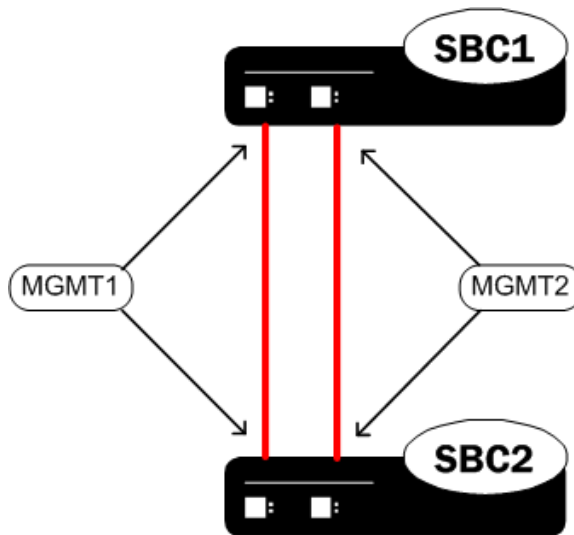

Mgmt1/Mgmt2 Connections on SBC1 and SBC2

8. Refer to the configuration procedures located in the HA Nodes chapter of the Acme Packet Configuration Guide.

Media Cabling for HA Nodes

NIU media port cabling in an HA node depends on network topology. After a switchover between the two Acme Packet 6300/6350 in an HA node, the standby system sends out an ARP message using a configured virtual MAC address, establishing that MAC on another physical port on the same Ethernet switch.

5

Startup

This chapter describes the Acme Packet 6300/6350 startup; this includes the following tasks:

- Powering on the Acme Packet 6300/6350.
- Creating the first console connection to the Acme Packet 6300/6350.

You can perform these actions in any order. However, if your console connection is configured first, you can observe the booting processes as your Acme Packet 6300/6350 goes online.

The last section of this chapter explains how to login to your system.

Creating a Console Connection

This section explains how to create a console connection.

Prerequisites

In order to create a console connection to the Acme Packet 6300/6350 you need to configure the terminal hardware and software appropriately. The following table lists your terminal application's serial configurations.

Table 5-1 Serial Connection Settings

Serial Connection Parameter	Setting
Baud Rate	115,200 bps
Date Bits	8
Parity	No
Stop Bit	1
Flow Control	None



Note:

Your terminal application and serial port MUST be capable of operating at 115.2 Kbps for creating a console session.

Creating a Console Connection

To create a console connection:

1. Set the terminal application's parameters to match the Acme Packet 6300/6350 default parameters listed in the table above.
2. You must connect to the console port on initial booting of the Acme Packet 6300/6350.

3. If the Acme Packet 6300/6350 is already powered on, press the Enter key a few times to activate the console connection. When ACLI text is displayed on the screen, the console connection has been successfully created.
4. If you have created the console connection before powering up the Acme Packet 6300/6350, you can watch the boot process as it displays on your screen.

Powering On the Acme Packet 6300/6350

This section explains how to power on your Acme Packet 6300/6350.

Note:

There is a slight difference between the Acme Packet 6300 and Acme Packet 6350 platforms in regards to powering on the system. The Acme Packet 6300 has no ON/OFF switches, while the Acme Packet 6350 has a System Power switch, which enables you to control the power to the system. For more information on the Acme Packet 6350's System Power switch, see *Rear View*.

To power on the Acme Packet 6300/6350 hardware:

1. Plug in the power cord. If you have the Acme Packet 6300, the power turns on and the system starts to boot. If you have the Acme Packet 6350, put the System Power switch into the ON position and the power turns on and the system starts to boot. For more information on the System Power switch, see *Rear View*.
2. When operating with redundant power supplies, both power supplies must be plugged in either simultaneously or within a few seconds of each other. Otherwise, an alarm is generated.
3. The graphic display on the front control panel will begin to display information.

Initial Login

Once you have established the console connection, powered on the Acme Packet 6300/6350 and a runtime image has been loaded, you are ready to log in and begin configuring the system. After the Acme Packet 6300/6350 System has been initialized, the ACLI login prompt appears in your terminal application as follows:

```
User Access Verification  
Password:
```

If the Acme Packet 6300/6350 completed booting before you connected to the console port, press the Enter key on the console keyboard a few times to activate the console connection.

System access in the following procedure uses the default User and Superuser passwords. If you do not have the default passwords, please contact your customer support representative.

1. At the CLI password prompt, enter the default system User password and press <return>. Your entries are not echoed on the screen.

```
User Access Verification
Password:
ACMEPACKET>
```

From the User prompt you can view various configuration states and operating statistics on the Acme Packet 6300/6350 System, but you perform configuration tasks.

2. Type **enable** and press return to enter Superuser mode. The prompt to enter the superuser password appears.

```
ACMEPACKET> enable
Password:
```

3. Enter the Superuser password and press return. The system prompt ends with a pound sign instead of a closed-angle-bracket to let you know are in Superuser mode.

```
Password:
ACMEPACKET#
```

4. You can now begin configuring your Acme Packet 6300/6350 System. Refer to the Acme Packet Configuration Guide to learn how to establish an IP address for your Acme Packet 6300/6350 System.

If you have any questions about booting or powering on your system, contact your Acme Packet customer support representative directly.

Formatting the Solid State Drive

After the initial log on to the device, you must format the Solid State Drive. Details on file system designs and the formatting procedure may be found in the *File System Maintenance* chapter of the Maintenance and Troubleshooting Guide.

6

Maintenance

System Shut Down

This chapter explains Acme Packet 6300/6350 hardware maintenance procedures and provides hardware alarm information. Although several user-replaceable components of the Acme Packet 6300/6350 are hot-pluggable, some Acme Packet 6300/6350 maintenance procedures require that you shut down the system.

Before you shut down or restart the Acme Packet 6300/6350, ensure that there are no active calls in progress. Procedures to reroute call and network traffic around the Acme Packet 6300/6350 are outside the scope of this guide.

You can set the Acme Packet 6300/6350 to reject all incoming calls from your system with the **set-system-state** command. When set to offline, this command lets calls in progress continue uninterrupted, but no new calls are admitted.

After all call processing has stopped, you must halt the operating system before you power off your Acme Packet 6300/6350. Shutting down the system is appropriate when you are replacing a physical interface card, storage device, power supply, or are removing the Acme Packet 6300/6350 from the equipment rack.

Shutting down the Acme Packet 6300/6350

- In Superuser mode, type **halt** and then press Enter. Then, at the halt confirmation prompt, answer **y** followed by Enter.

```
ACMEPACKET# halt
-----
WARNING: you are about to halt the SD!
-----
Halt this SD [y/n] ? : y
Preparing for system shutdown
Syncing and unmounting filesystems
Flushing sd devices
Powering off.....
Sent SIGKILL to all processes
Requesting system power off
Disabling non-boot CPU's.....
Power down.
```

Rejecting Incoming Calls

To reject all incoming calls on the Acme Packet 6300/6350:

- In Superuser mode, type **set-system-state offline** and press Enter.

```
ACMEPACKET# set-system-state offline  
Setting system state to going-offline, process will complete when  
all current calls have completed  
ACMEPACKET#
```

Shutting Down the Acme Packet 6300/6350 Console

To shut down the Acme Packet 6300/6350 hardware:

1. Exit the ACLI and close your console or network connection.
2. Unplug the AC power cords from the power supplies on the rear panel of the Acme Packet 6300/6350.
3. Confirm that the graphic display is dark and all fans are off.



Dark Graphic Display When Acme Packet 6300/6350 is Shut Down

Rebooting, Resetting, and Power Cycling

Reboot

Rebooting the Acme Packet 6300/6350 shuts down the system in an orderly fashion and then starts it up again. The operating system gracefully shuts down as processes are terminated and the file system is stopped. While the system and its processes are stopped, all call processing is immediately halted. You may therefore wish to perform tasks that call for a reboot during off-peak maintenance hours.

Rebooting the Acme Packet 6300/6350 is required every time you upgrade with a new version of the Acme Packet 6300/6350 software.

Before rebooting the Acme Packet 6300/6350, save your configurations. The **save-config** command is used to save the configuration in the example below.

For a full explanation and all options for the **reboot** command used in the example below, refer to the ACLI Reference Guide.

To reboot the Acme Packet 6300/6350:

1. Save any configuration changes you have made in the CLI by typing **save-config** Enter in Superuser mode.

```
ACMEPACKET# save-config
Save-Config received, processing.
waiting 1200 for request to finish
Request to 'SAVE-CONFIG' has Finished,
Save complete
Currently active and saved configurations do not match!
To sync & activate, run 'activate-config' or 'reboot activate'.
ACMEPACKET#
```

2. Execute the **reboot** command at the Superuser prompt by typing **reboot** and then pressing Enter.

```
ACMEPACKET# reboot
-----
WARNING: you are about to reboot this SD!
-----
```

3. Type **Y** and then press Enter at the confirmation prompt to proceed with the reboot.

```
Reboot this SD [y/n]?: y
```

System Reset

Resetting the Acme Packet 6300/6350 via the rest button on the front of the chassis performs a cold reboot. This is the equivalent to disconnecting the power from the system and then reconnecting it. There is no orderly termination of tasks, and the system shuts down abruptly. You should only reset the Acme Packet 6300/6350 in this way when it becomes unstable and there is no other possible means of gaining administrative control.

During a system reset, certain files are not closed properly, and they may become corrupted. Depending on what files become damaged, the system might become completely unusable.

Note:

Always try to first reboot the Acme Packet 6300/6350 from the CLI before performing a cold reset. Only reset the system as a last resort.
To reset the Acme Packet 6300/6350:

- Insert a rigid paperclip-sized tool into the small hole on the front of the chassis beneath the graphic display. The system immediately resets and begins its initialization and boot sequence.



Reset Button

Power Cycling

Power Cycling the Acme Packet 6300/6350 is the process of turning the chassis off and then turning it on by plugging and then unplugging the AC power cords from the power supplies. It is imperative that you wait at least 10 seconds between power down and power up to ensure that all components are completely powered down before restart.

Note:

Power cycling the Acme Packet 6300/6350 without performing a halt operation can lead to data loss to the storage device. To ensure stable operation a file system check will be performed on the next power up. This check may take several minutes to complete, and should not be interrupted.

Standby Mode for HA Nodes

When performing hardware maintenance on the Acme Packet 6300/6350, it is best to minimize any risk of interrupting network traffic or losing data. If the Acme Packet 6300/6350 is configured as an HA node, you should only work on the Acme Packet 6300/6350 that is in standby mode.

There are two ways to determine the HA state of each Acme Packet 6300/6350 in an HA pair.

1. If you are in the same physical location as the Acme Packet 6300/6350, you can view the graphic display on the front panel. The display will indicate the HA state. There is no (S) designation for an active system, but there is for a standby system.
2. If you are not in the same physical location as the Acme Packet 6300/6350, you can use the ACLI **show health** command. The output of this command indicates the current HA state of the Acme Packet 6300/6350.

Once you have determined that the Acme Packet 6300/6350 due for maintenance is in standby mode, you can continue with the appropriate procedures to replace a part.

If you need to perform maintenance on the active Acme Packet 6300/6350, you need to manually force the two Acme Packet 6300/6350s to switch HA states. Performing a switchover forces the currently active Acme Packet 6300/6350 to

standby mode while the current standby Acme Packet 6300/6350 will assume all traffic processing and forwarding as the active system.

 **Note:**

This procedure is only applicable to Acme Packet 6300/6350 in an HA deployment.

To force a Acme Packet 6300/6350 into the standby HA state:

3. Confirm that the relevant systems on SBC1 and SBC2 are synchronized with the **show health** command. Type **show health** and press Enter on each system.

```
system-1# show health
```

```
Media Synchronized           true
SIP Synchronized             true
REC Synchronized             disabled
MGCP Synchronized            disabled
H248 Synchronized            disabled
XSERV Synchronized           disabled
Config Synchronized          true
Collect Synchronized         disabled
RADIUS CDR Synchronized      true
Rotated CDRs Synchronized    true
IPSEC Synchronized           true
Iked Synchronized            disabled
TSCF Synchronized            disabled
Active Peer Address
```

```
Redundancy Protocol Process (v3):
```

```
State
```

```
Active
```

```
Health                               100
Lowest Local Address                  169.254.1.2:9090
1 peer(s) on 2 socket(s):
system-2: v3, Standby, health=100, max silence=1050
    last received from 169.254.1.1 on wancom1:0
```

```
system-2# show health
```

```
Media Synchronized           true
SIP Synchronized             true
REC Synchronized             disabled
MGCP Synchronized            disabled
H248 Synchronized            disabled
XSERV Synchronized           disabled
Config Synchronized          true
Collect Synchronized         disabled
RADIUS CDR Synchronized      true
Rotated CDRs Synchronized    true
IPSEC Synchronized           true
Iked Synchronized            disabled
TSCF Synchronized            disabled
```

```

Active Peer Address          169.254.2.2

Redundancy Protocol Process (v3):

State                        Standby

Health                       100

Lowest Local Address
169.254.1.1:9090
1 peer(s) on 2 socket(s):
system-1: v3, Active, health=100, max silence=1050
last received from 169.254.2.2 on wancom2:0

```

4. Confirm that SBC1 and SBC2's current configurations match by typing **display-current-cfg-version** and press Enter at the ACLI prompt.

```

NETNETSBC1# display-current-cfg-version
Current configuration version is 5
NETNETSBC1#
NETNETSBC2# display-current-cfg-version
Current configuration version is 5
NETNETSBC2#

```

 **Note:**

While the two current configuration version numbers on the two systems MUST match each other, they do not have to match the shared running configuration version.

5. Confirm that the running configuration of SBC1 and SBC2 match by typing **display-running-cfg-version** and pressing Enter at the ACLI prompt.

```

NETNETSBC1# display-running-cfg-version
Running configuration version is 5
NETNETSBC1#
NETNETSBC2# display-running-cfg-version
Running configuration version is 5
NETNETSBC2#

```

 **Note:**

While the two running configuration version numbers on the two systems MUST match each other, they do not have to match the shared current configuration version.

6. Initiate a switchover on SBC1 by typing **notify berpd force** and pressing Enter at the ACLI prompt.

```

NETNETSBC1# notify berpd force

```

7. Wait for SBC2 to transition to the standby state. Confirm that SBC2 is in the standby state by typing **show health** and pressing Enter at the ACLI prompt.

```
NETNETSBC2# show health
```

Refer to the Upgrade section of the Maintenance and Troubleshooting Guide (400-0063-40A) for more information.

Replacing an NIU in an HA Node

Refer to NIU/TCU Removal and Replacement on page 6-79. Before replacing the NIU in an HA node, refer to these steps.

1. Prepare all equipment connected to the NIU for the NIUs removal from the network.
2. Force the system to standby state as described in the previous section.
3. Log in to the ACLI via a console connection.
4. Reboot the system from the ACLI.

When this Acme Packet 6300/6350 returns online, it will synchronize the HA state with the active HA node using the new NIU. You can confirm the system state by using the **show health** command.

Chassis Removal

This section explains how to remove the Acme Packet 6300/6350 from an equipment rack. To prevent injury, we recommend that any time an Acme Packet 6300/6350 is installed or removed from an equipment rack, two people complete the procedure.



Note:

Always disconnect the Acme Packet 6300/6350 power supplies from the power source when removing a chassis from an equipment rack.

Removing the Acme Packet 6300/6350 from an Equipment Rack

To remove the Acme Packet 6300/6350 from an equipment rack:

1. Disable the two power sources to the Acme Packet 6300/6350.
2. Remove the two AC/DC power cords from the power supplies in the back of the system. (There are no ON/OFF switches on these power supplies).
3. Remove all power cables from the Acme Packet 6300/6350.
4. Remove and label all attached network cables, alarm cable, and console cables from their respective ports on the chassis.
5. Remove ground cable from the rear of the Acme Packet 6300/6350. Save the hex nuts for later re-installation.

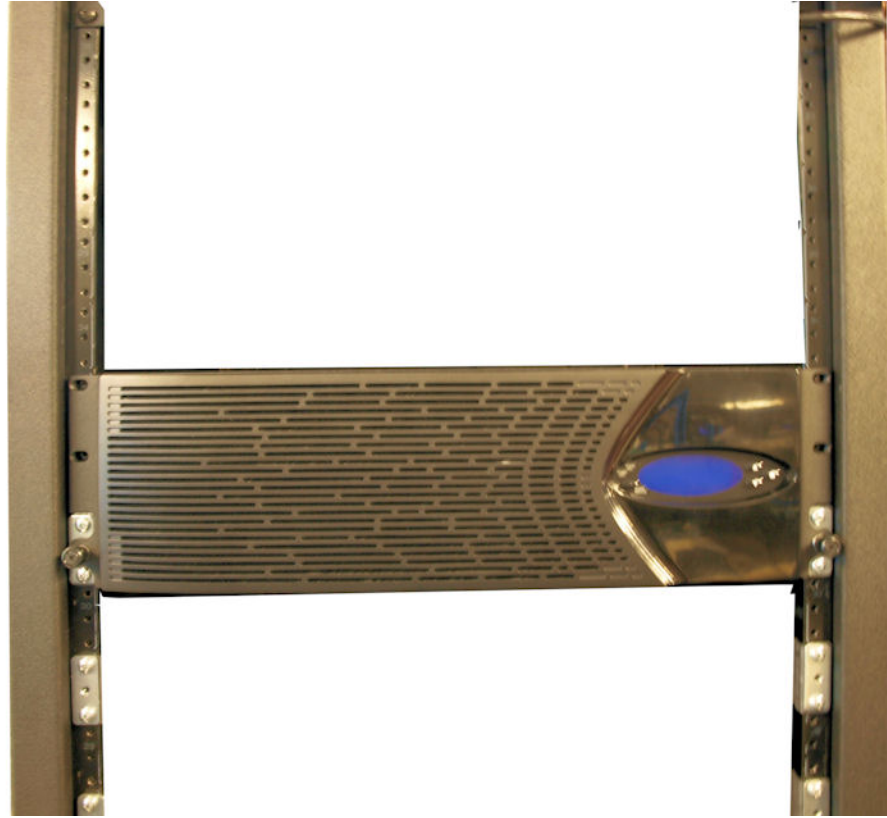

Loosen two thumbscrews securing the Acme Packet 6300/6350 to the Rack

6. Loosen the 2 thumbscrews that secure the Acme Packet 6300/6350 to the rack rails. This may require using a #2 Phillips screwdriver.

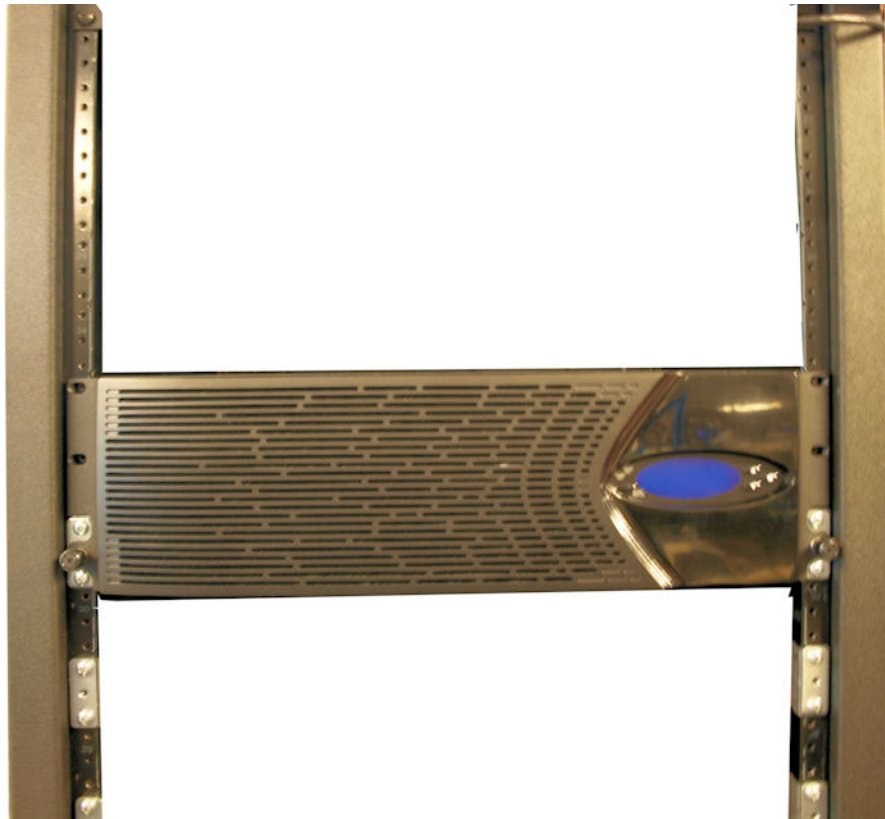

Thumbscrews Securing the Acme Packet 6300/6350 to the Rack

 **Note:**

Beginning in this step, one person should support the Acme Packet 6300/6350 from below while the other person removes the system chassis from the equipment rack.

7. Pull the Acme Packet 6300/6350 forward and out of the equipment rack.

 **Note:**

The slides have a mechanical safety stop about halfway down the slide. To fully remove the chassis, you must depress the release latch points on the chassis slides.

8. Lift the Acme Packet 6300/6350 out of the equipment rack, and move it to an ESD safe location.

ESD

When removing and replacing a power supply, remember to first ground yourself using appropriate ESD grounding equipment such as an ESD wrist strap.



ESD Wrist Strap

Power Supply Removal and Replacement

This section explains how to remove and replace the power supplies in the Acme Packet 6300/6350. This section is for both AC and DC power supplies.

 **Note:**

There is an ESD receptacle in the top left corner in the rear of the Acme Packet 6300/6350.



ESD Receptacle

Turn the power source off before you remove or install the power supply.

The power supply is a user-replaceable component. If an Acme Packet 6300/6350 power supply malfunctions, you should remove the malfunctioning power supply and replace it. The power supply can be removed from the chassis while still installed in the rack and while the second power supply is providing system power; replacing a power supply while a second power supply continues to provide power is called a warm swap.

Both power supplies used in the Acme Packet 6300/6350 must be the same type (AC or DC). The power supplies must be populated with two identical power supplies made by the same vendor. The vendor is identified by the label on top of the power supply.

Removing a Power Supply

To remove a power supply from the Acme Packet 6300/6350:

1. Remove the AC or DC power cables from the power supplies.

Figure 6-1 Removing the Power Cords

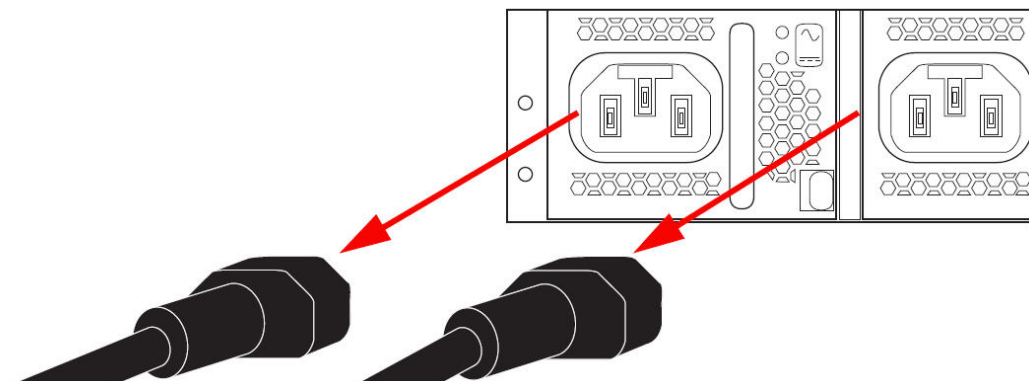

2. With your thumb, push the grey locking tab to the left to unlock the power supply from the chassis (1).

Figure 6-2 Releasing the Locking Tab

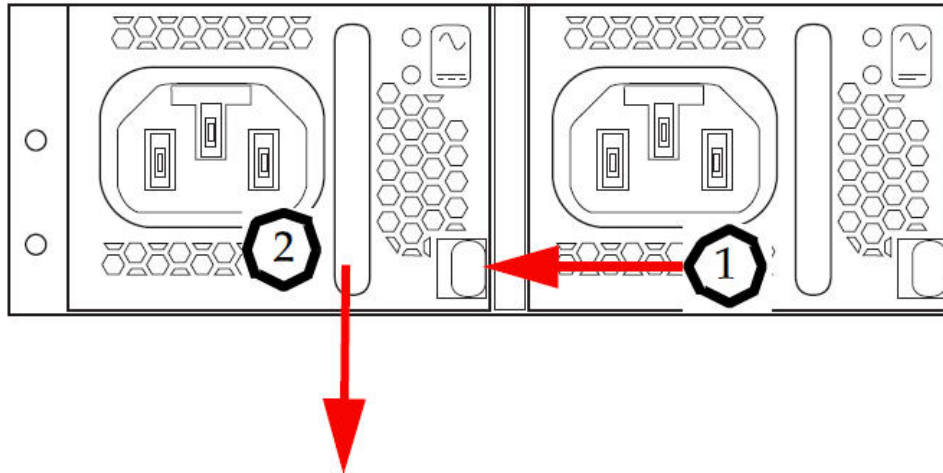

3. Holding the handle (2), pull the power supply towards you. This will disengage the power supply from the chassis.
4. Continue pulling the power supply towards you until it is completely removed from the chassis.
5. Move the power supply to an ESD-safe location.

Installing a Power Supply



Note:

NEVER power up a power supply before it is installed in the Acme Packet 6300/6350 chassis.

Ground yourself with an ESD wrist strap before installing a power supply.

To install a power supply in the Acme Packet 6300/6350 chassis:

1. Locate the power supply to be installed.
2. Locate the empty power supply slot in the chassis.
3. Insert the power supply into the empty power supply slot located on the rear panel of the Acme Packet 6300/6350 chassis.

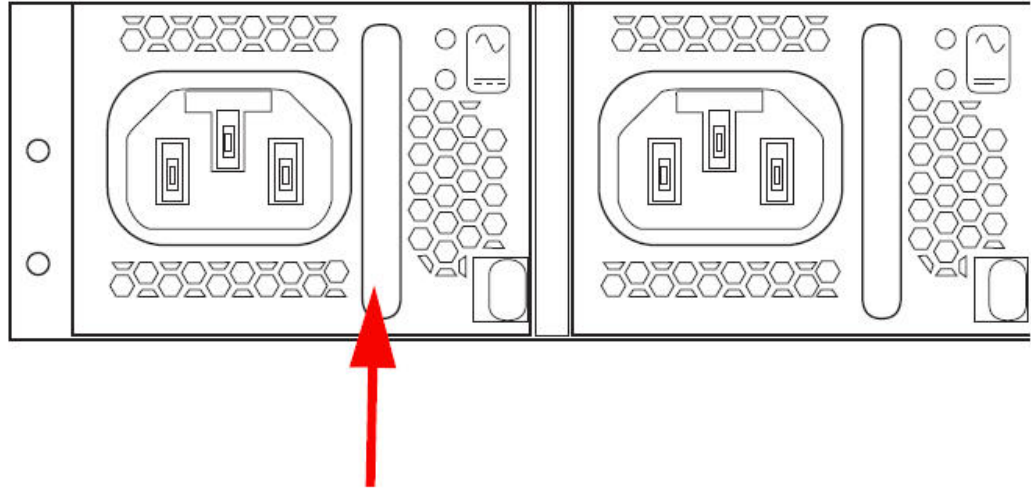

Installing the Power Supply

4. Push the power supply handle until the power supply is engaged with the chassis.
5. The power supply is installed in the Acme Packet 6300/6350 chassis.

 **Note:**

Connect the power cord to the inserted power supply.

NIU/TCU Removal and Installation

This section describes how to remove and replace either an NIU or a transcoding Carrier Unit (TCU). Both of these components are fastened to the rear of the Acme Packet 6300/6350 using the same type hardware (i.e., ejection levers and captive thumbscrews).

Prior to removing an NIU/TCU, the platform in which it is installed must be in standby before powering down the chassis and removing the component(s). The following procedure describes how to remove an NIU/TCU.

 **Note:**

Make sure you are properly grounded with an ESD strap before removing the NIU/TCU.

 **Note:**

Images in this section reflect the Acme Packet 4600. The procedures are the same for the AP6350 NIU and TCU.

NIU/TCU Removal

Prior to removing an NIU (Network Interface Unit), the platform in which it is installed must be in standby state if it is part of a HA pair before powering down the chassis and removing the NIU. The following procedure describes how to remove an NIU.

Note:

Make sure you are properly grounded with an ESD strap before removing the NIU.

To remove an NIU/TCU:

1. Ensure that the Acme Packet 6300/6350 on which the NIU/TCU is being replaced is in standby mode by following the steps described elsewhere in this document.
2. Unplug the power cords to power down the chassis.
3. Unplug all network and management cables (NIU only) you plan to remove from the Acme Packet 6300/6350.
4. Using a #2 Phillips screwdriver, unscrew the two captive thumbscrews located on each side of the NIU/TCU. The screws are spring-loaded and will push forward, but they will not fall out of the NIU/TCU.

Figure 6-3 Loosening Captive Thumbscrews (NIU Shown)



Caution: Failure to follow this step may cause damage to the NIU ejectors: With thumb and index finger slide ejector levers inward prior to pivoting ejectors

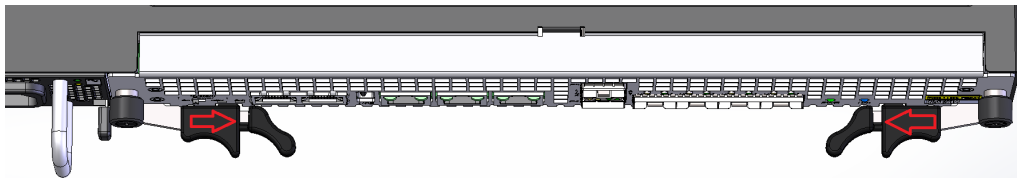

5. Slide the lever catch and pivot the two ejector levers outward at the same time, pulling the card out of its connection to the motherboard and away from the system chassis. This action disengages the NIU/TCU from the system, severing all

electrical contact to the processing unit.



6. Remove the loosened NIU/TCU out of the Acme Packet 6300/6350 by holding and pulling on each side of the NIU's front panel.
7. Place the NIU/TCU in an antistatic bag while it remains outside of the Acme Packet 6300/6350.

NIU/TCU Installation

To install an NIU/TCU into the Acme Packet 6300/6350 chassis:

1. Locate the NIU/TCU.
2. Ensure that the ejection levers on the front of the NIU/TCU are in the open and extended position.
3. Hold the NIU/TCU by its sides with the front panel bezel facing you.
4. Note the two flared guide rails that the NIU/TCU rides as it is inserted into the Acme Packet 6300/6350. The guide rails lead the NIU/TCU to engage with the bus connector squarely.

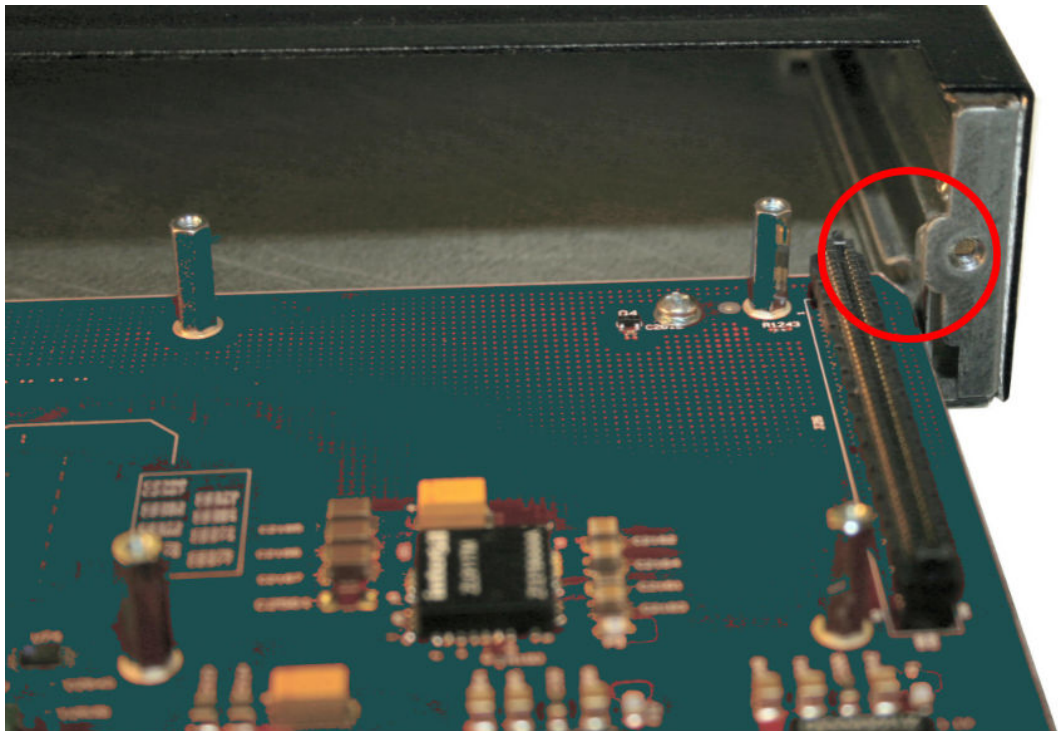

Aligning the NIU/TCU Card with the Chassis Slot Guides

5. Slide the NIU/TCU into the Acme Packet 6300/6350.

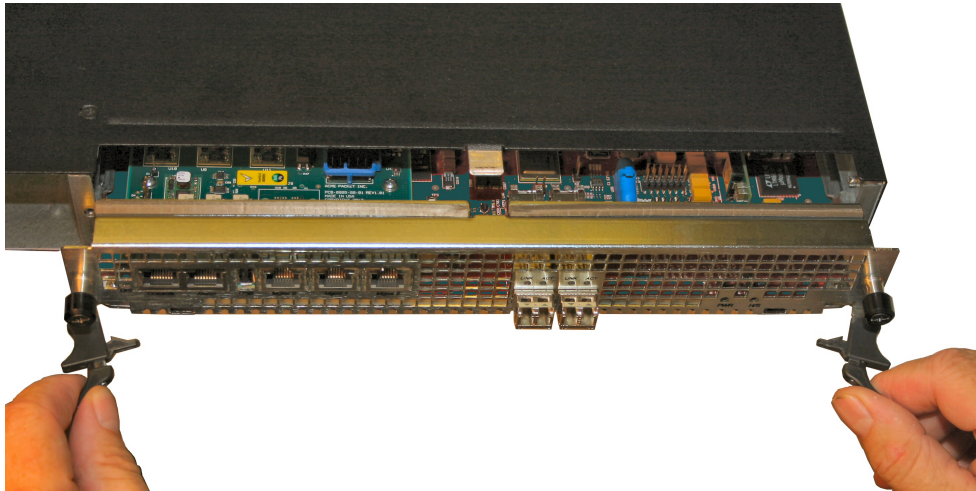

Installing the NIU/TCU (NIU Shown)

6. Continue sliding the NIU/TCU into the chassis until the ejection levers catch the chassis. At this point, the ejection levers will start to fold inward as the NIU/TCU is inserted into the chassis.
7. Fold both ejection levers inward toward the face of the NIU/TCU to draw the physical interface card toward the system chassis complete the connection to the motherboard.

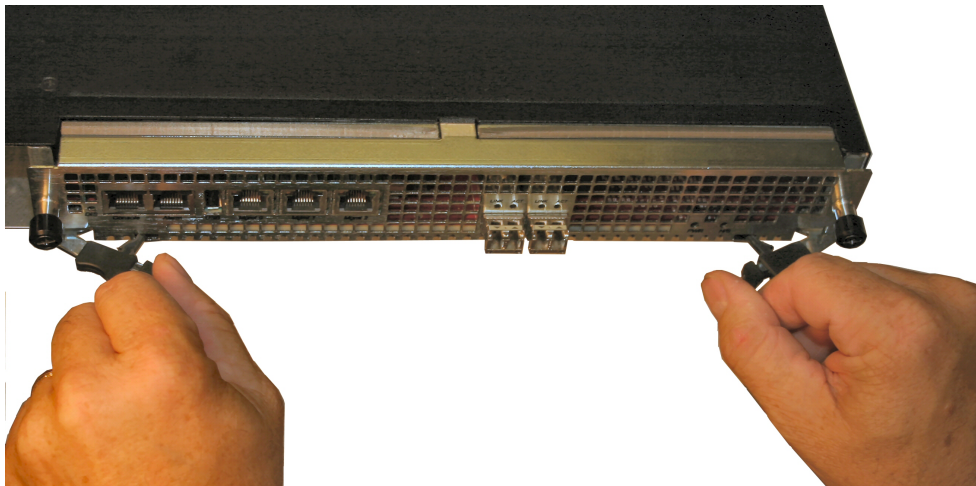

Locking the NIU/TCU to the Chassis (NIU Shown)

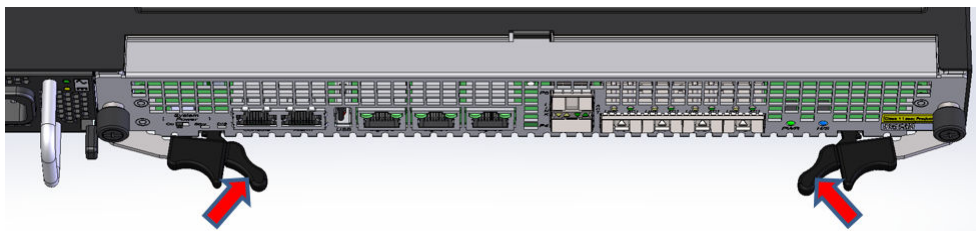

Ensure pressure is applied to the ends of the ejector (not the sliding section) when seating the NIU/TCU

8. Verify the lever catch is fully engaged with the bezel.
9. Screw the NIU/TCU thumbscrews into the chassis with a #2 Phillips screwdriver. This creates the final connection between the interface unit and the chassis.



Tightening NIU/TCU Thumbscrews

10. Replace all network and management cabling.
11. Replace all power cables. The system boots up.
12. If the H/S LED lights in either a steady or flashing state, the NIU is not seated properly. If the H/S LED is lit, follow these steps:

Unplug the power cords to power down the chassis.

Push the ejection levers inward to draw the physical interface card toward the system chassis and complete the connection. The latches must engage to complete NIU insertion. Verify the lever catch is fully engaged with the bezel.

Replace all power cables. The system boots up.

When the NIU PWR LED is lit and the H/S LED is extinguished, proceed with normal operations. Otherwise, contact customer support for further assistance.

Replacing the SSM3 Module

The SSM3 module that provides TLS security functionality to the Acme Packet 6300/6350 is installed on the NIU PCB as shown below. There is a single connector located on the edge of the NIU into which the SSM3 module plugs; the SSM3 module is screwed into four standoff posts on which it is supported.

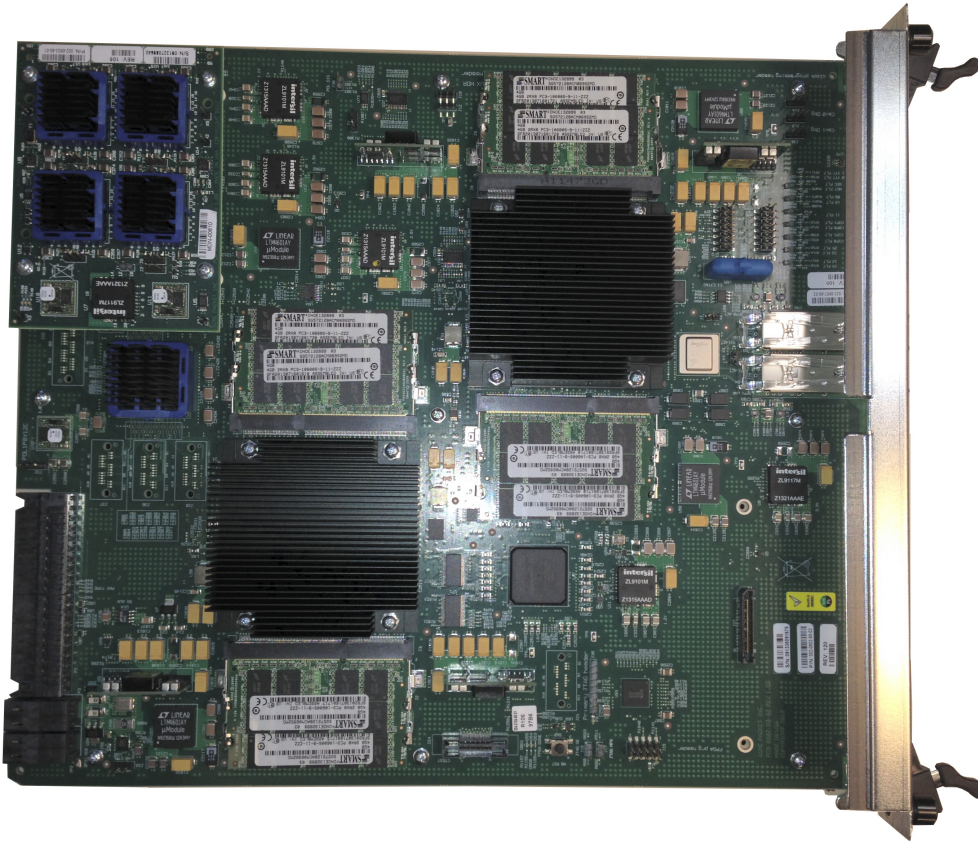

Location of the SSM3 Module (Mounted on Acme Packet 6300/6350)

Pre-Installation Guidelines

Please read and follow these pre-installation guidelines prior to replacing the SSM3 module:

- The SSM3 module can be installed only in the designated location.
- Note the installation location of the SSM3 module on the NIU PCB.
- Ground yourself and follow proper ESD grounding procedures.
- Remove the SSM3 from the shipped packaging.
- Install the SSM3 according to the procedure below.
- This upgrade should be performed during low-traffic periods or during times of scheduled maintenance.
- Follow industry-standard procedures to ensure ESD protection.
- When installing or removing an NIU card, move the card to an ESD-safe location.

 **Note:**

Before handling a Acme Packet 6300/6350 NIU card, follow the proper ESD grounding procedures. Failure to do so could damage the NIU card and its components.

Required Parts

The following parts are required to replace the SSM3 module:

- ESD wrist strap
- ESD safe location
- SSM3 Module
- NIU Card

Removing the SSM3 Module

The following procedure describes how to remove the SSM3 module located on the Acme Packet NIU card.

Prerequisites:

- Provide an ESD-safe location to place the SSM3 and NIU card.
- Wear an ESD wrist strap or take similar equivalent actions to prevent static damage to the NIU card or other ESD-sensitive components.
- Note the location of the SSM3 module connector on the NIU card.

- #2 Phillips screwdriver

To remove the SSM3 module:

1. Remove the NIU card as directed in this document.
2. Place the NIU card on an ESD-safe mat or other similar location.
3. Using the Phillips screwdriver, remove the four standoff screws from the SSM3 module and store them for later reuse.
4. To remove the module (shown below), grasp the SSM3 module along either side of the connector between your thumb and index finger and pull up on one side of the connector until the module is fully disconnected from the connector. Place the module on an ESD-safe surface.

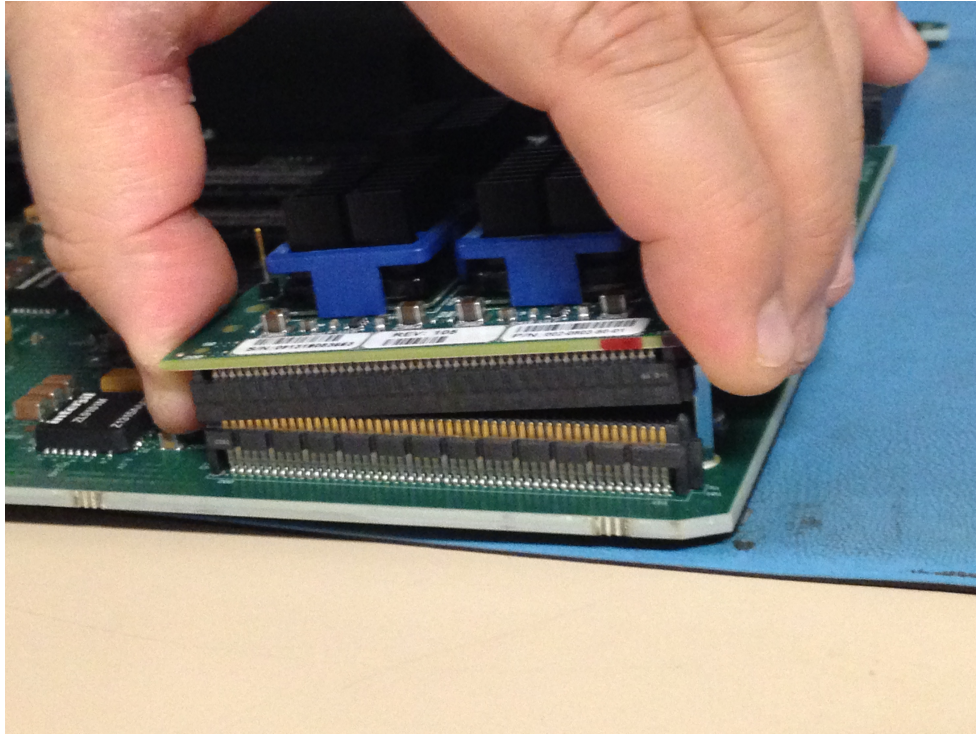

Removing the SSM3 Module

Installing the SSM3 Module

The following procedure describes how to install the SSM3 module onto the Acme Packet NIU card.

Prerequisites:

- Place the new SSM3 module in an ESD-safe location.
- Wear an ESD wrist strap or take similar equivalent actions to prevent static damage to the NIU card or other ESD-sensitive components.
- Note the location of the SSM3 module connector on the NIU card.
- #2 Phillips screwdriver
- Standoff screws (stored after removing the SSM3 module or available with the new SSM3 module)

To install the SSM3 module:

1. Grasp the SSM3 module along either side of the connector between your thumb and index finger and join the module connector to the NIU connector by pressing evenly across the connector until the module is fully seated (see below).

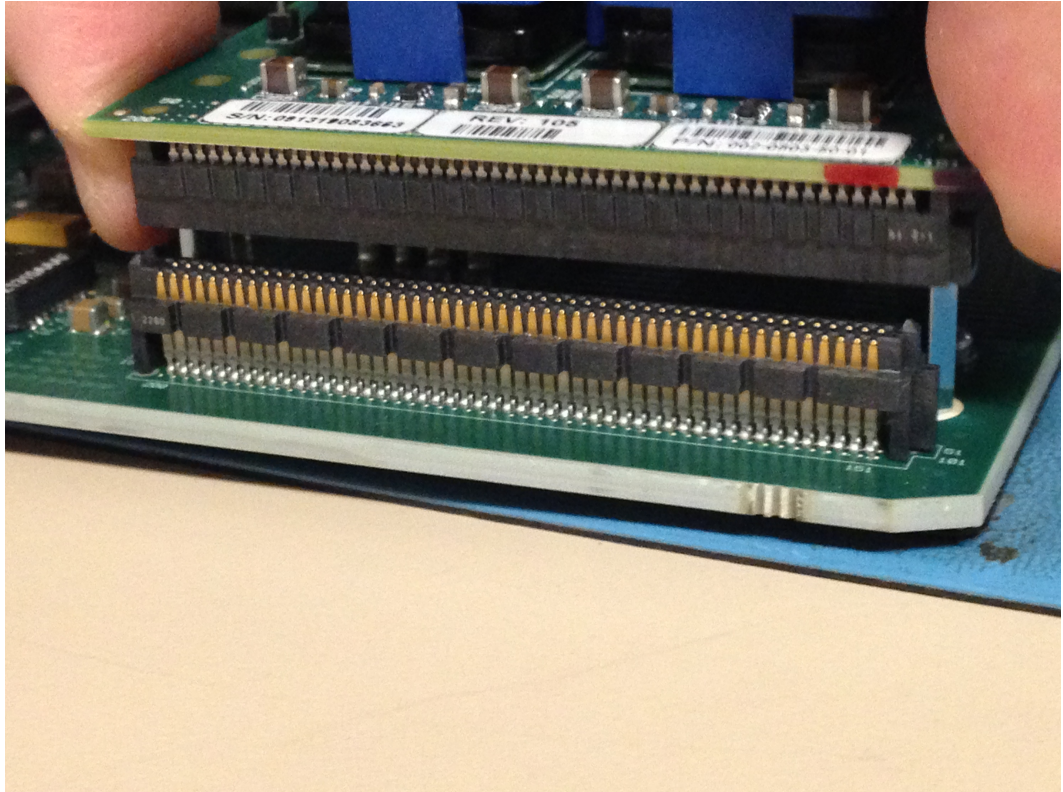

Installing the SSM3 Module

Press evenly across the top of the connector to fully seat the SSM3 module on the NIU PCB as shown below. Note that the SSM3 is fastened to the NIU through four standoffs attached to the NIU as shown in the figures below.

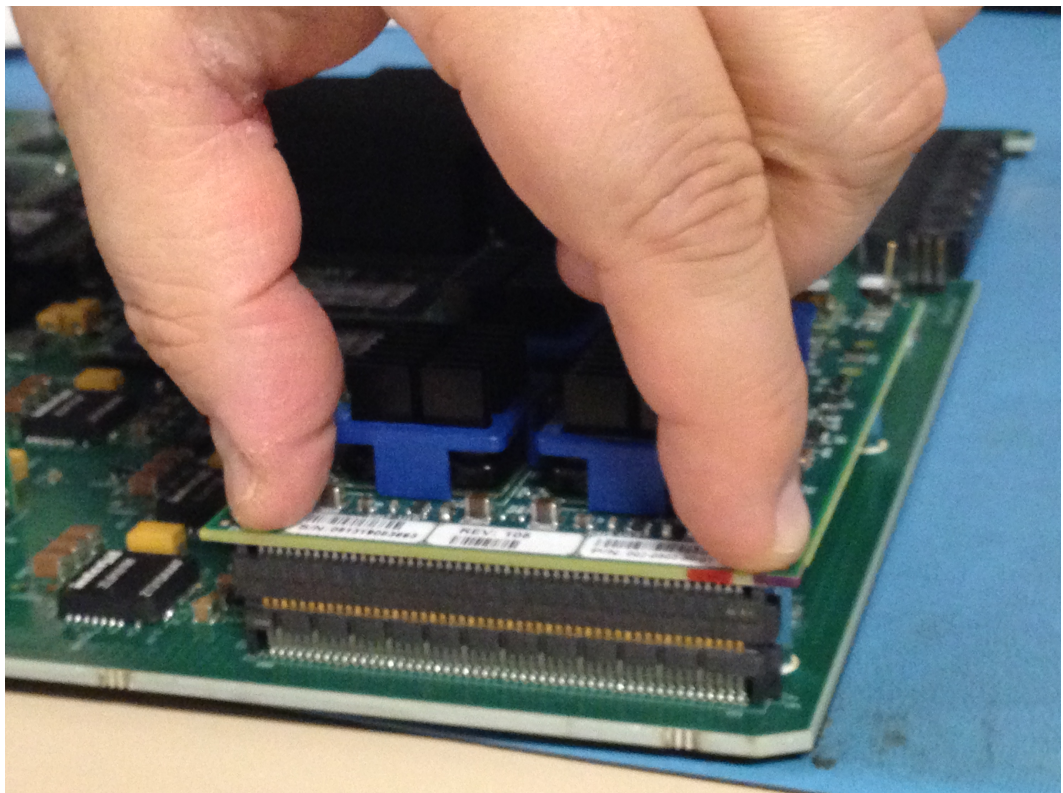

Fully Seating the SSM3 Module Connector

2. Using the Phillips screwdriver, insert and tighten the four standoff post screws to secure the SSM3 module to the PCB.

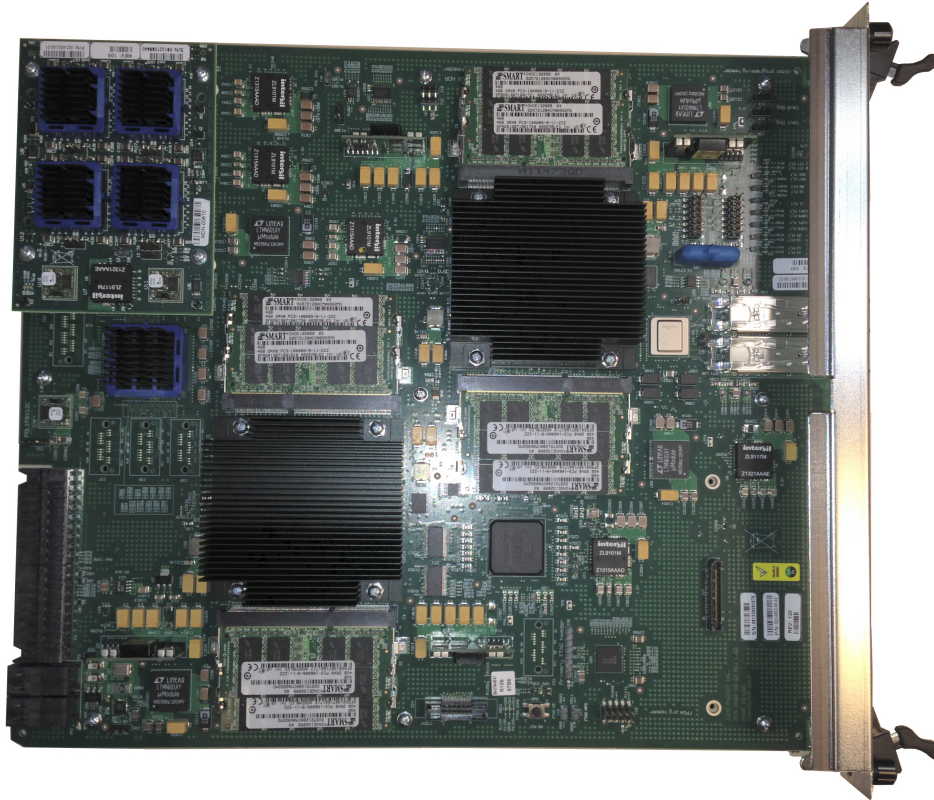

Location of the SSM3 Module Standoff Posts

Replacing Transcoding Modules

The Acme Packet 6300/6350 supports up to twenty-four Transcoding Modules (TM) for transcoding functionality. The TMs are installed in slots 0 through 23 on the TCU. There are slots for installing the TMs in three locations on the PCB (three groups of eight slots - See Figure 6 - 105). TMs must be installed consecutively in numerical order, starting with slot 0. Slot numbering starts at the lower left slot with 0-7, slots 8-15 in the group to the directly to the right, then slots 16-23 directly above the right group.

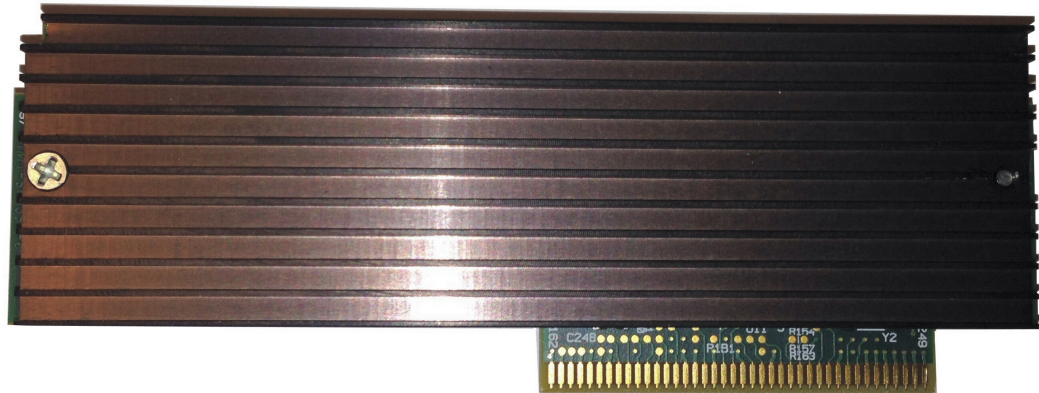

Transcoding Module

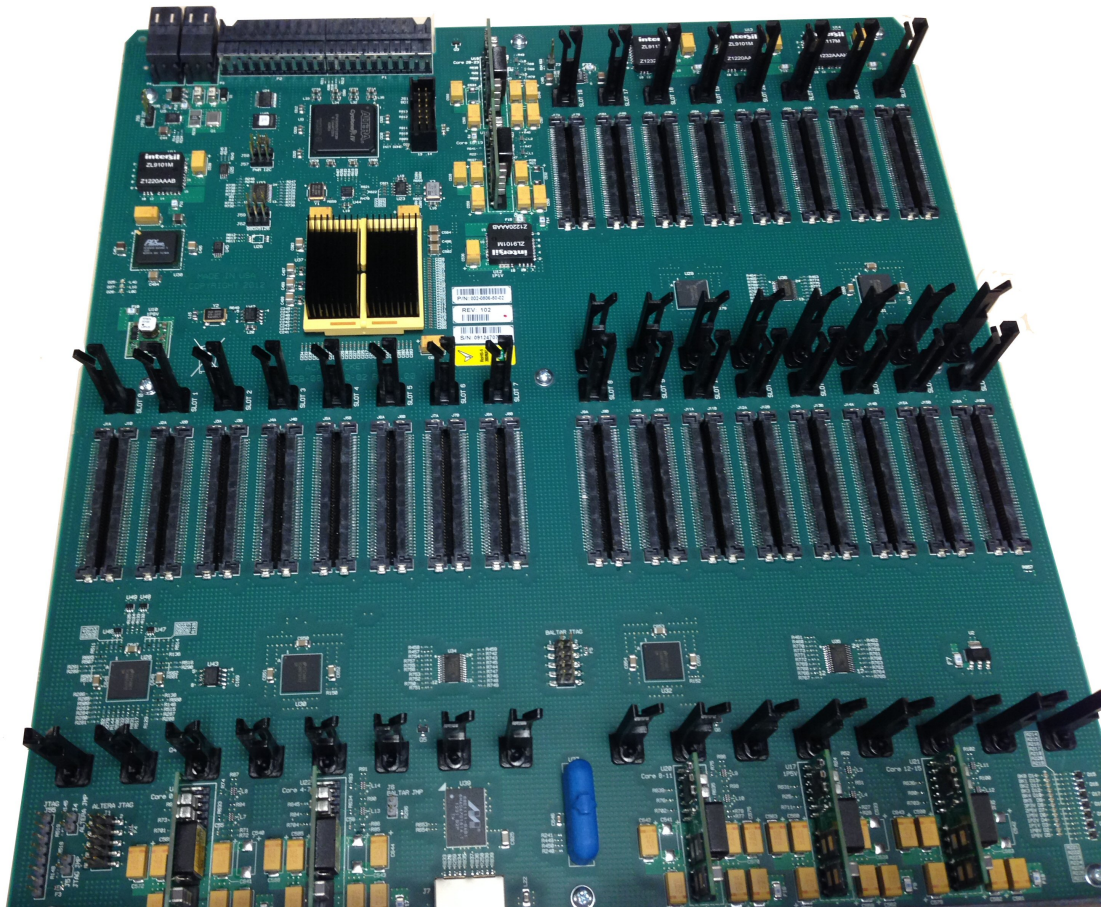

Locations of TMs on the TCU

Installation and Removal Guidelines

Please read and follow these guidelines prior to installing or removing the Transcoding Module (TM):

- The TM can be installed only in the designated location.

- Note the installation locations of the TM on the TCU.
- Ground yourself and follow proper ESD grounding procedures.
- Remove the TM from the shipped packaging.
- Remove and install the TM according to the procedures below.
- This upgrade should be performed during low-traffic periods or during times of scheduled maintenance.
- Follow industry-standard procedures to ensure ESD protection.
- When installing or removing a TCU, move the card to an ESD-safe location.

 **Note:**

Before handling an Acme Packet 6300/6350 TCU, follow the proper ESD grounding procedures. Failure to do so could damage the TCU and its components.

Required Parts

The following parts are required to replace the TCU:

- ESD wrist strap
- ESD-safe location
- Transcoding Module
- TCU

Removing the Transcoding Module

The following procedure describes how to remove the Transcoding Module (TM) from the TCU.

Prerequisites:

- Provide an ESD-safe location to place the TM and TCU.
- Wear an ESD wrist strap or take similar equivalent actions to prevent static damage to the TCU or other ESD-sensitive components.
- Note the location of the TM connector on the TCU.
To remove the TM:
 1. Remove the TCU as directed in the Acme Packet 6300/6350 Service Manual.
 2. Place the TCU in an ESD-safe location.
 3. To remove the TM (as shown in the photos below), use a fingertip to release the catch holding either end of the module.



Releasing the Fastener Holding the TM (1 of 2)

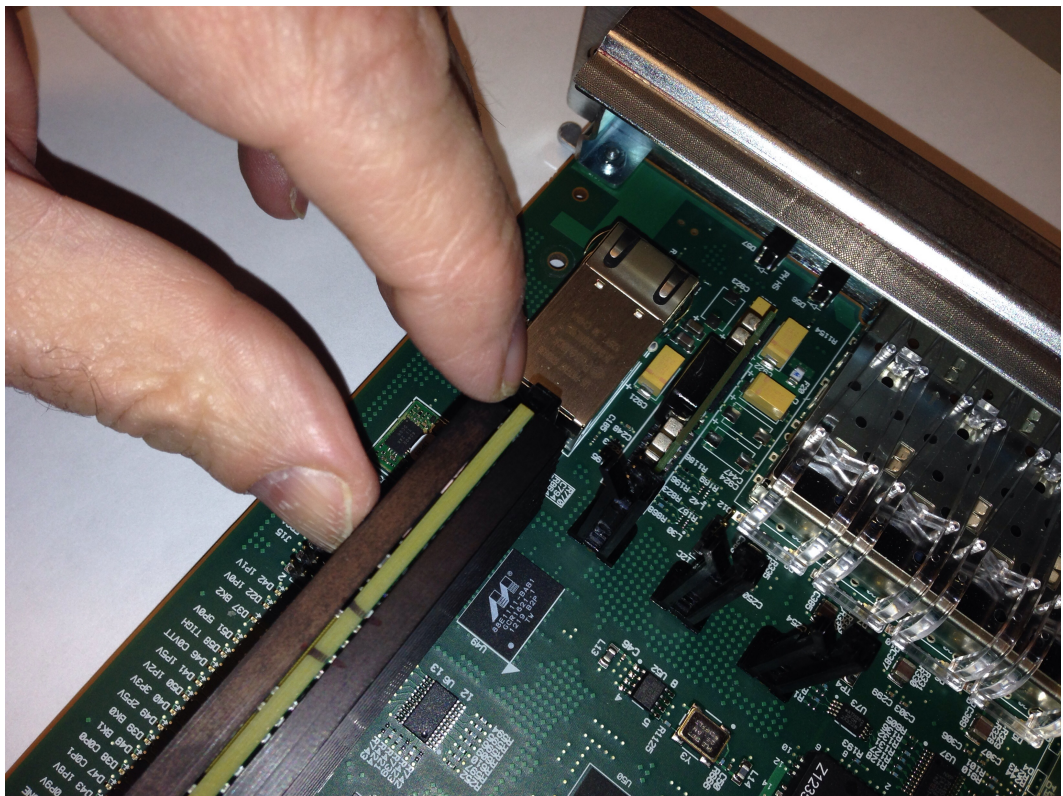

Releasing the Fastener Holding the TM (1 of 2)

4. Once the fastener is detached from one side of the TM, slightly lift up on that side of the module and then disengage the other fastener on the other side of the TM and lift up on that side of the module.
5. When both sides are free of the fasteners, hold the center of the module between your finger and thumb and slowly remove the module. Be careful to keep the module level while removing it and guide it smoothly through the guide slots on either side.

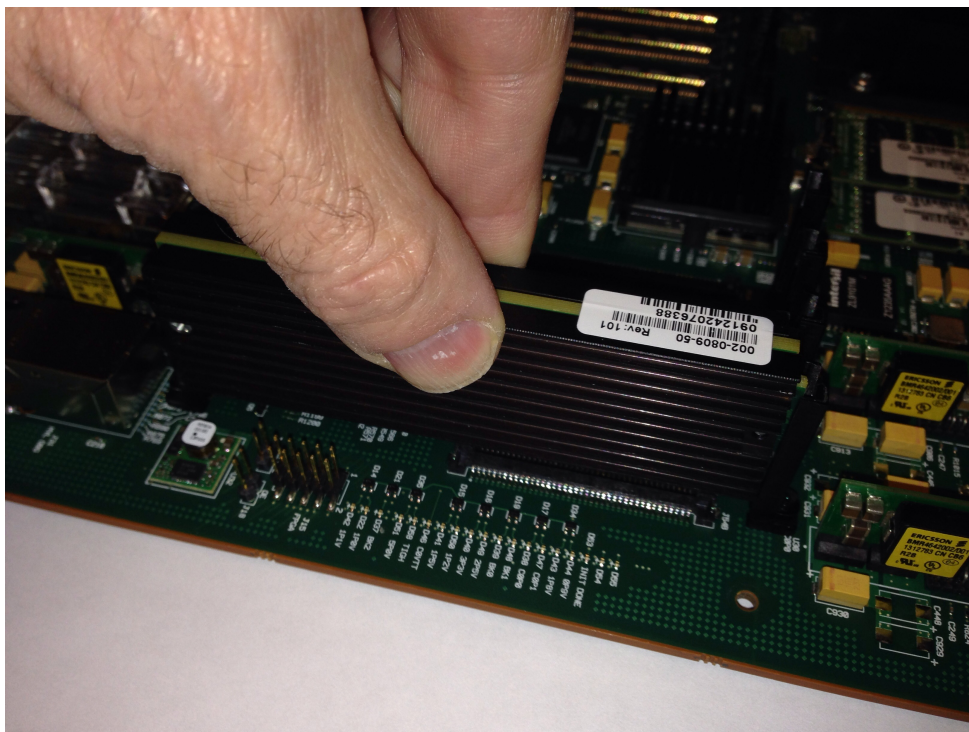

Removing the TM

6. Place the TM on an ESD-safe antistatic surface.

Installing the Transcoding Module

The following procedure describes how to install the Transcoding Module (TM) onto the TCU.

Prerequisites:

- Place the new TM in an ESD-safe location.
- Wear an ESD wrist strap or take similar equivalent actions to prevent static damage to the TCU or other ESD-sensitive components.
- Note the location of the TM connector on the TCU.

To remove the TM:

1. Grasp the TM between your thumb and index finger of each hand and line up both sides of the module with the slot guides attached to the TCU (see below).

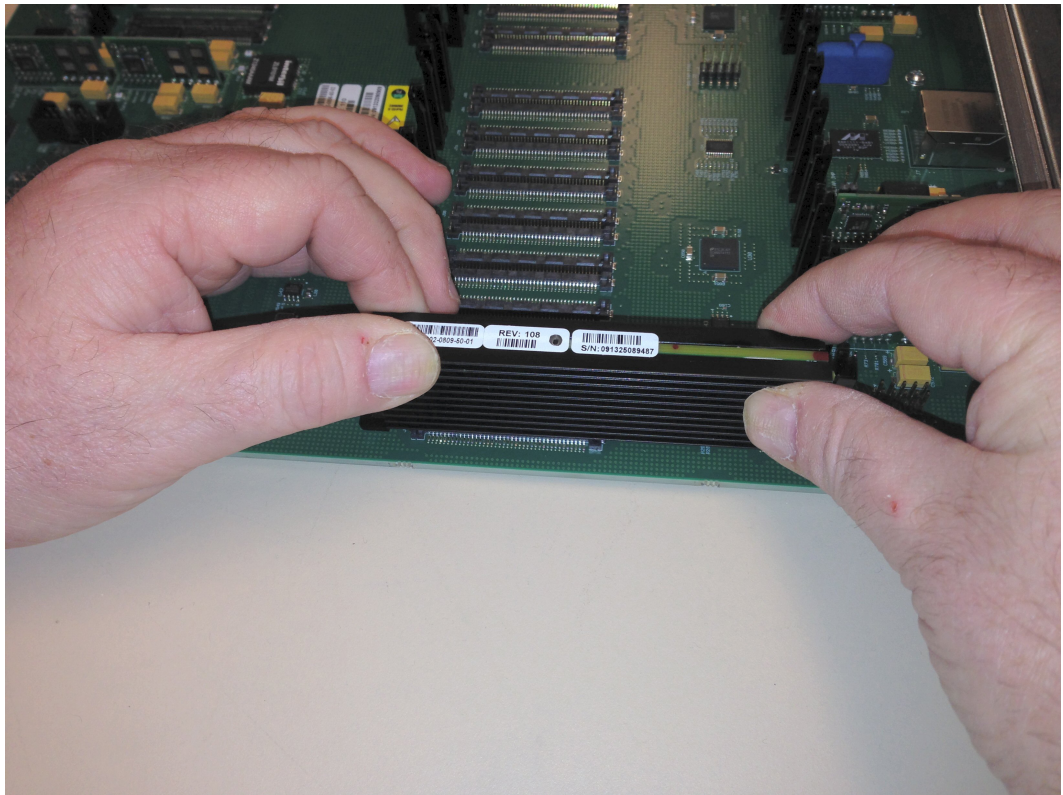

Installing the TM

2. Guide the module evenly into the slot guides located on each side as you lower the component into the connector. Press evenly across the top of the connector to fully seat the TM on the TCU as shown below.

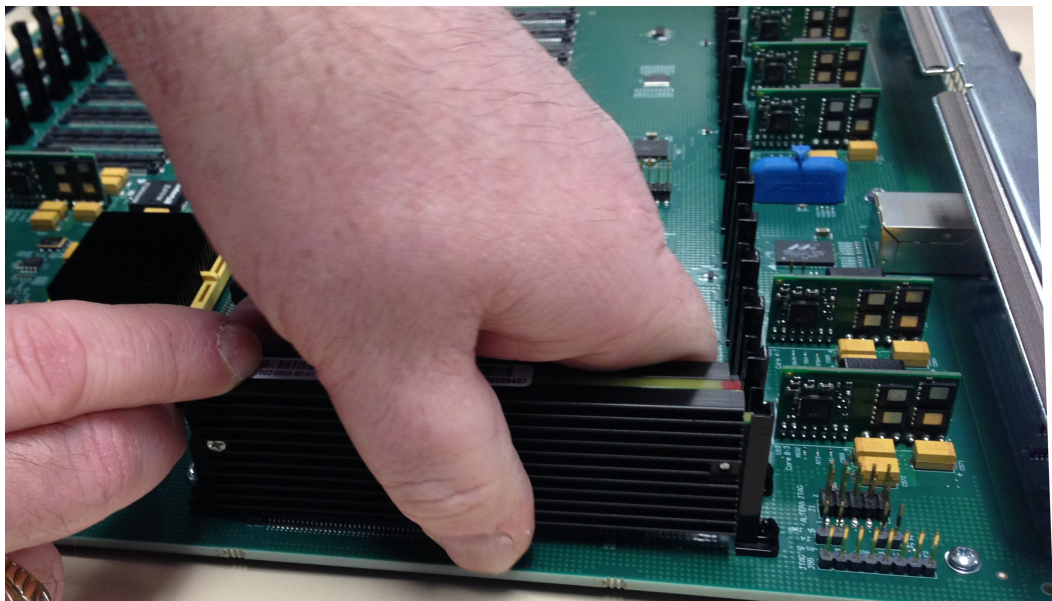

Seating the TM

Replacing the SSD

This section explains how to remove and replace the solid state drive (SSD) on your Acme Packet 6300/6350.

The SSD is a user-serviceable, component. There is only one SSD located on the Acme Packet 6300/6350. If the Acme Packet 6300/6350 experiences an SSD malfunction, you must remove the existing SSD and replace it with a functional one.

The SSD is located on the top left rear of the Acme Packet 6300/6350 chassis.



Note:

After replacing the SSD, you must format it. Details on file system designs and the formatting procedure may be found in Chapter 9, File System Maintenance of the Maintenance and Troubleshooting Guide for your software release.

Removing the SSD

The procedure in this section describes how to remove the SSD from the Acme Packet 6300/6350.

Prerequisites:

- Place the SSD in an ESD-safe location.
 - Wear an ESD wrist strap or take similar equivalent actions to prevent static damage to the SSD or other ESD-sensitive components.
- To remove an SSD:
1. Using a #2 Phillips screwdriver, unscrew the two captive screws located on each side of the face of the SSD. The screws are spring-loaded and will push forward, but they will not fall out of the door.

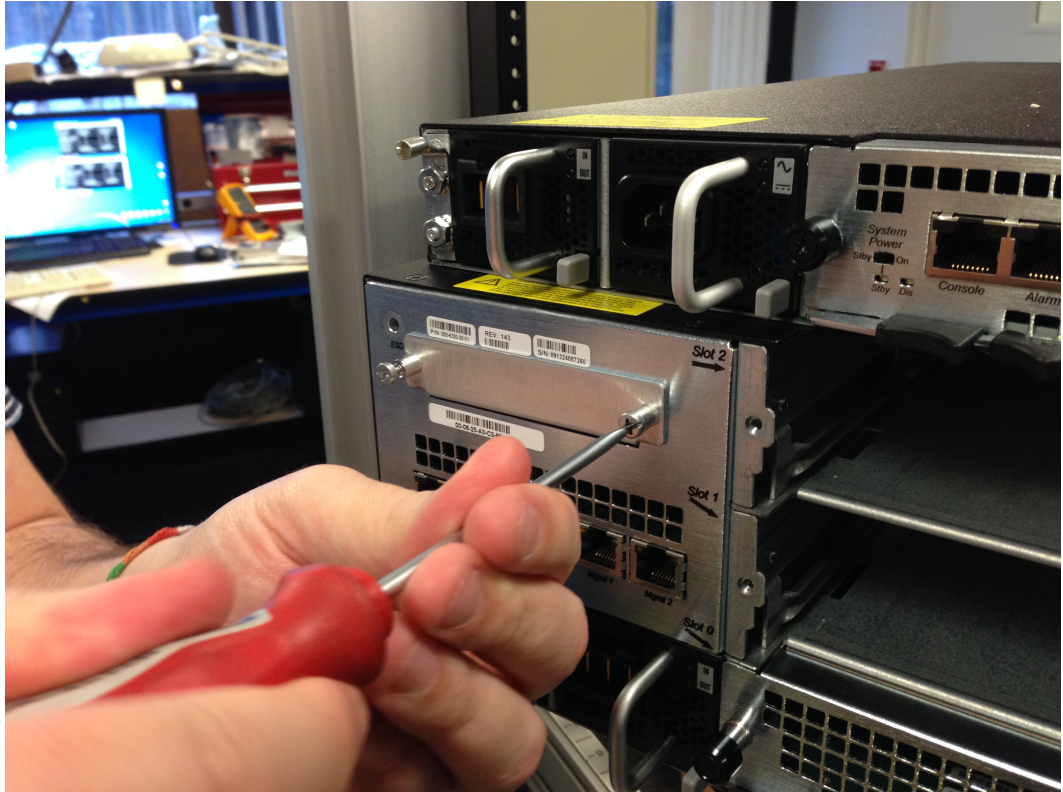

Loosening SSD Screws

2. Pull on one of the two captive screws and support the base of the SSD as you pull it out of the chassis to remove it. Please place the removed SSD in an ESD-sensitive location.



Removing the SSD

Installing the SSD

The procedure in this section describes how to install the SSD into the Acme Packet 6300/6350.

Prerequisites:

- #2 Phillips screwdriver or a bladed screwdriver
- Place the SSD in an ESD-safe location.
- Wear an ESD wrist strap or take similar equivalent actions to prevent static damage to the SSD or other ESD-sensitive components.

To install an SSD:

1. Insert the new SSD into the empty SSD slot on the top left rear of the Acme Packet 6300/6350 chassis.
2. Push on the face of the SSD to properly seat the connectors with the chassis as shown below. When seated properly, the face of the SSD will be flush with the exterior of the chassis.



Seating the SSD

3. Using a screwdriver, tighten the two spring-loaded captive screws located on each side of the door covering the SSD.

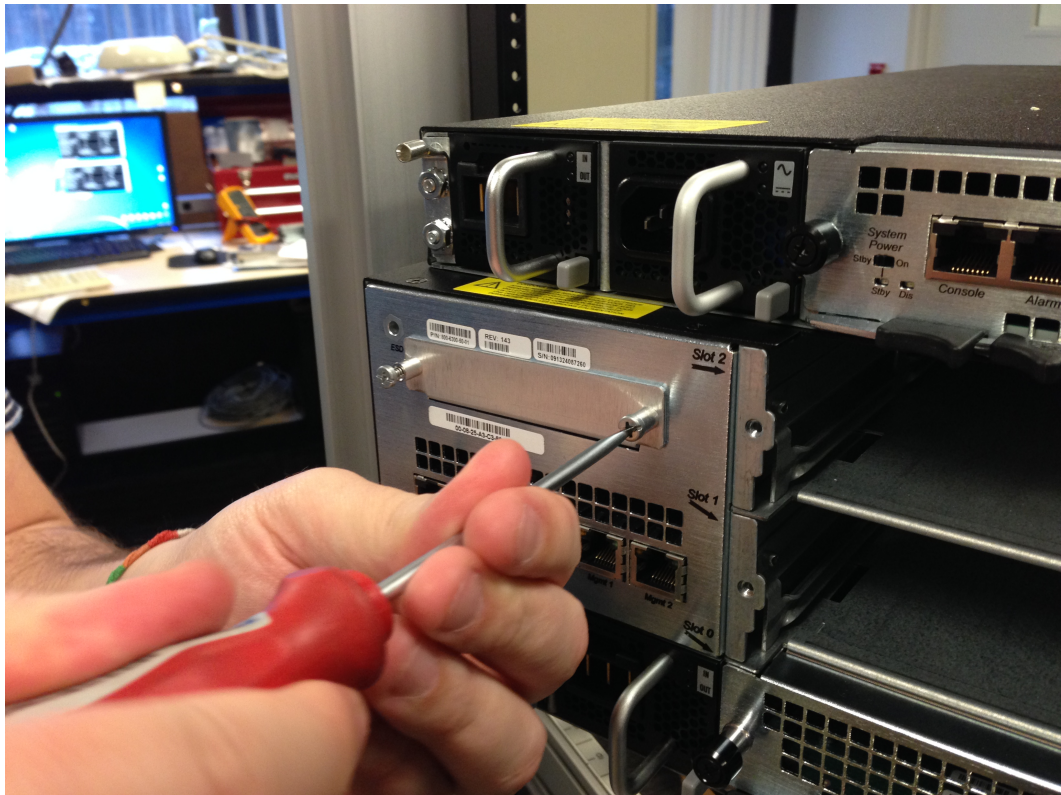

Tightening the Captive Thumbscrews

 **Note:**

After replacing the SSD, you must format it. Details on file system designs and the formatting procedure may be found in Chapter 9, File System Maintenance of the Maintenance and Troubleshooting Guide for your software release.

Fan and Filter Maintenance

This section explains how to remove and replace a fan and filter on your Acme Packet 6300/6350.

Remove and Install Individual Fans

The individual fan is a user-serviceable, hot-pluggable component. There are 15 individual fans in the Net- Net 6300. If the Acme Packet 6300/6350 experiences a fan malfunction, you must remove the existing fan and replace it with a functional one.

The hot-pluggable fan removal and replacement procedures require that you have a replacement fan on hand. In order to maintain system operations you must be able to remove the malfunctioning fan and quickly replace it with a functioning one to prevent the system from overheating.

 **Note:**

An over temperature condition can stop packet processing.
If you do not have a replacement fan nearby, always shut down the system and disconnect the power before removing the malfunctioning fan to replace it at a later time.

When removing and replacing a fan, remember to first ground yourself using appropriate ESD grounding equipment such as a wrist or heel strap.

To remove a fan:

1. Press two fingers against the left end of the plastic fan bezel and pull it directly toward you. There are 4 posts that hold the bezel in place.



Acme Packet 6300/6350 With Attached Bezel

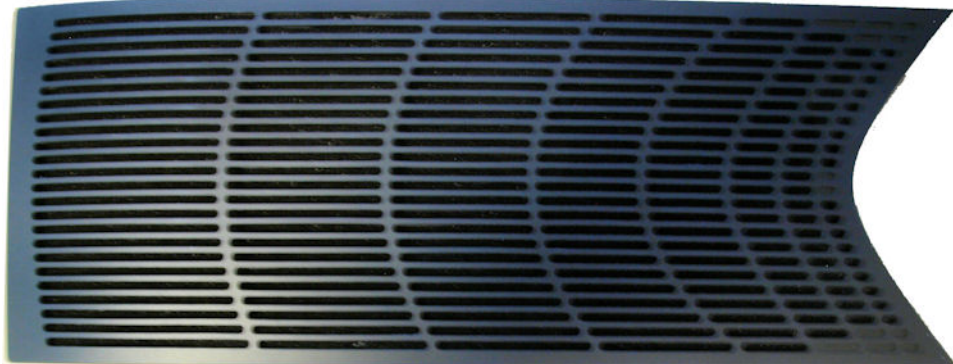

Front Bezel

2. The back side of the bezel holds the fan filter and is outfitted with four receptacles to attach to four chassis posts that hold the bezel in place on the chassis

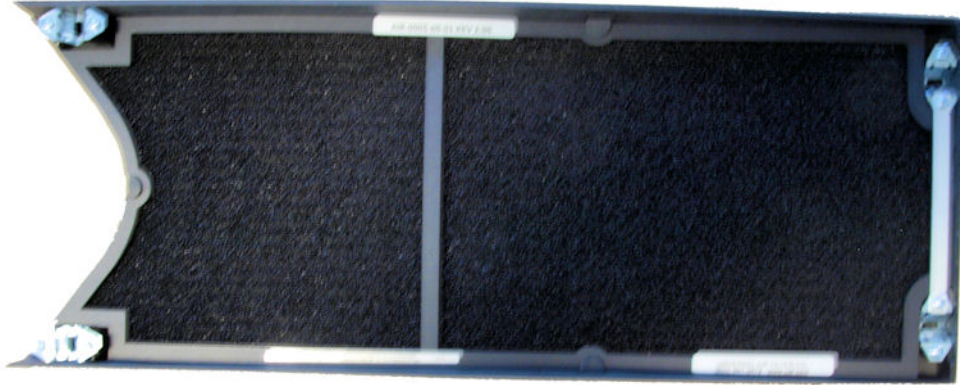

Back Side of the Front Bezel

3. Set the fan bezel aside.

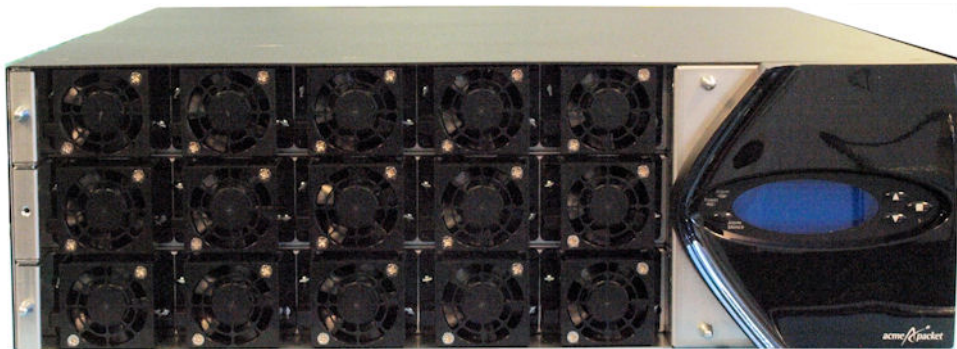

Acme Packet 6300/6350 Fans

 **Note:**

The 15 individual Fans are in the front of the chassis.
There are two flat head screws on either side of the Fan, that hold each Fan in place.

4. Using a flathead screwdriver, unscrew the two flat head captive screws at each side of the individual fan you are replacing.

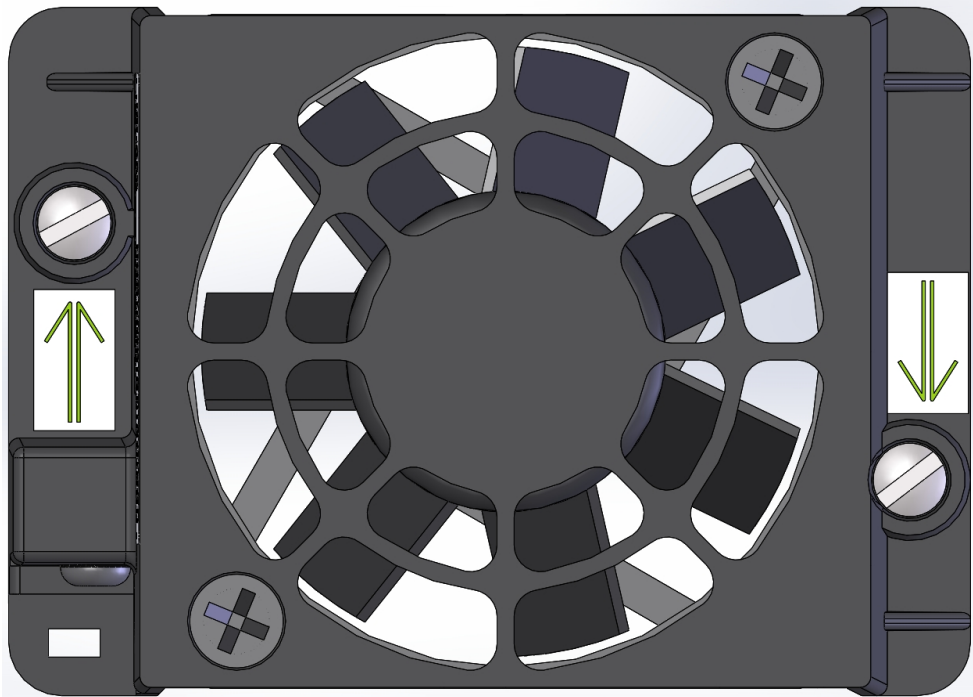

Captive Screws

5. Pull the individual fan you just unscrewed directly toward you and out of the chassis. Move the fan to an ESD safe location.

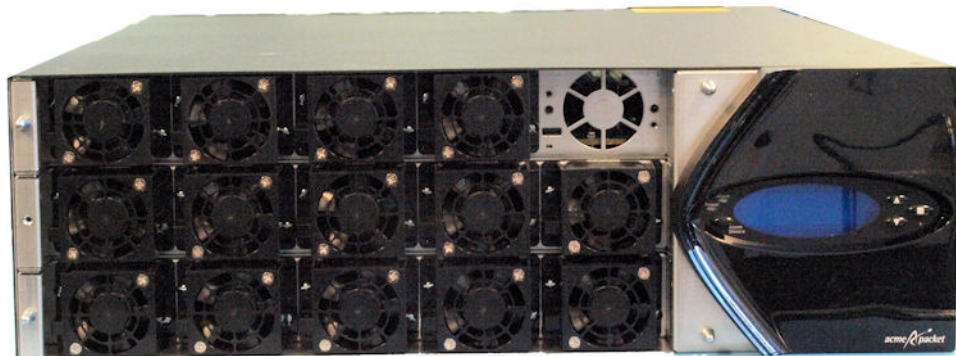

Removed Fan

To Install a Fan

To obtain a replacement fan, contact your Acme Packet customer support representative directly.

Replacing the fan is the reverse process of removing it.

To install an individual fan:

Note: The power connector should be on the lower side of the module when inserted into the Acme Packet 6300/6350 chassis.

1. Carefully align the pins on the back of the fan with the holes in the chassis midplane and install the fan into the slot.

Figure 6-4 Fan Slot Pin Holes

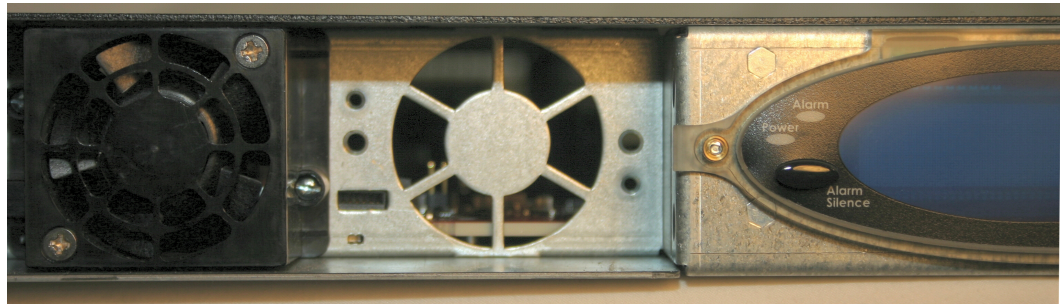
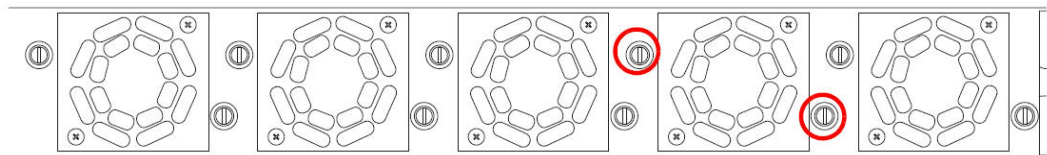

Figure 6-5 Inserting the Fan into the Chassis Slot



2. Using a small bladed screwdriver, tighten the two captive screws to hold the fan into place.

Figure 6-6 Tightening Fan-Fastening Screws



3. Install the front bezel onto the Acme Packet 6300/6350.

Maintaining the Cooling Components

The Acme Packet 6300/6350 Air Filter removes airborne particles before they are drawn into the Acme Packet 6300/6350. To prevent system malfunction and prolong the life of the system's cooling components:

- Clean or replace the fan filter every three months

- Clean the air inlets once a week.

Cooling maintenance encompasses cleaning the fan module and cleaning the air inlets on the front of the Acme Packet 6300/6350. Cleaning the fan module requires that you remove the module itself. If you are not shutting down the Acme Packet 6300/6350 this procedure must be performed quickly or else the system may overheat and cause packet processing to stop.

This maintenance should be performed alongside other preventive maintenance to take place within a planned maintenance or downtime window, during off-peak hours.

Cleaning the Cooling Components

To clean the Fan module:

1. Refer to the instructions detailed in this chapter's Fan and Filter Maintenance section to remove the fan from the chassis.
2. Spray compressed air into the fan to dislodge and blow away any contaminants and clean out the 15 fans.
3. Refer to the instruction detailed in this chapter's Fan and Filter Maintenance section to replace the fan module.

To clean the perforated air inlets:

4. Remove the fan bezel from the chassis.
5. Gently wipe the front fan bezel that contains the perforated air inlets with a clean, dry cloth. You can alternatively remove the fan bezel from the system and use compressed air to clean out the perforated air inlets.

Note:

Only the removable fan bezel has vent holes that require cleaning. To prevent damage to the painted finish, do not use any solvents or liquids to clean the perforated air inlets on the front of the chassis.

SFP+ Removal and Replacement

Your troubleshooting and diagnostics might reveal that the SFP+ component of an NIU card needs to be replaced. The SFP+ serves two functions:

- Converts electrical signals into optical signals used to communicate with other optical networking equipment.
- Serves as the receptacle for the LC duplex fiber optic connectors.

The SFP+ is hot swappable; it may be replaced while the Acme Packet 6300/6350 is powered on. Leave the NIU in the Acme Packet 6300/6350 as you extract the SFP+.

To obtain an SFP+, contact your Acme Packet sales representative directly.

SFP+ Media Signaling Interfaces

This section describes the media signaling interfaces, small form factor pluggable+ (SFP+). The signaling and media interface provides network connectivity for the signaling and media traffic. Each interface can connect to a network at 10-gigabit Ethernet speeds.

SFP+ Information

Only transceivers qualified by Acme Packet can be used in the Acme Packet 6300/6350. Mixed transceiver types are unsupported. Both transceiver locations must be populated with the same SFP+ type.

The SFP+s are inserted into the NIU card. These SFP+ types can be used:

- 850nm LASER PROD — check the label on the back of the SFP+ for this information to make sure you have the right mode transceiver. This multi mode SFP+ features a black bale clasp latch.
- 1310nm LASER PROD — check the label on the back of the SFP+ for this information to make sure you have the right mode transceiver. This single mode SFP+ features a blue bale clasp latch.

SFP+ Identification

The following image shows the 10-gigabit SFP+ multi mode transceiver used in the Acme Packet 6300/6350 NIU cards. The arrow indicates a black bale clasp latch.



10 Gigabit SFP+ Multi Mode Transceiver

The following image shows the single mode 10 gigabit SFP+ transceiver used in the Acme Packet 6300/6350 NIU cards. The arrow indicates a blue bale clasp latch.



10 Gigabit SFP+ Single Mode Transceiver

Media Cables

This section describes the media signaling interface, fiber optic cable, used in the NIU card that goes with the Acme Packet 6300/6350. The fiber optic cables only ship from Acme Packet if you order them.

Cable Information

- The fiber optic cable used on the Acme Packet 6300/6350 media cards is a 10 gigabit cable that connects to the NIU cards.

Cable Identification

The fiber optic cables used to connect to the NIU are shown in this section.



10 Gigabit Fiber Optic Cable (Aqua .50/125)

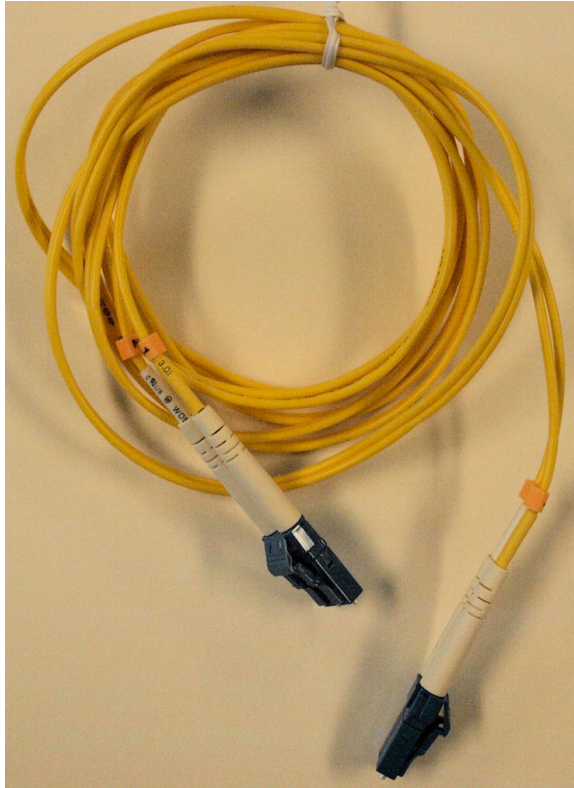

10 Gigabit Fiber Optic Cable (Yellow .9/125)

 **Note:**

To prevent damage to the optical lens, We recommend that the protective dust cover stay on the optical transceiver port when the 10GbE NIU card is not cabled.

Removing an SFP+

To remove the SFP+ from the NIU card:

1. Pull the bale SFP+ clasp latch out and down. It will pivot downwards on its hinge.

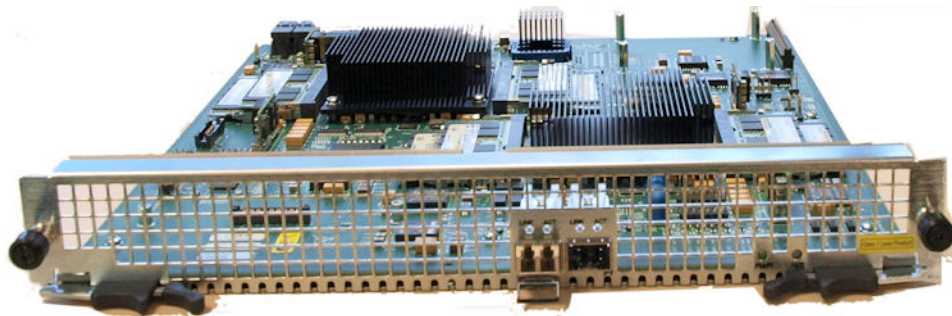

Pulling the SFP+ Transceiver Clasp Latch Out and Down

2. Holding the extended bale clasp latch, pull the optical transceiver fully out of its socket in the NIU card.

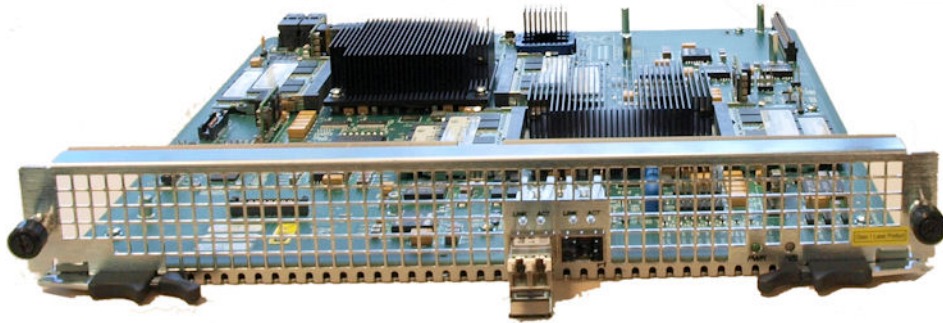

Removing the SFP+ Transceiver

Replacing an SFP+

To replace the SFP+:

1. Slide the replacement optical transceiver into the SFP+ socket on the NIU.

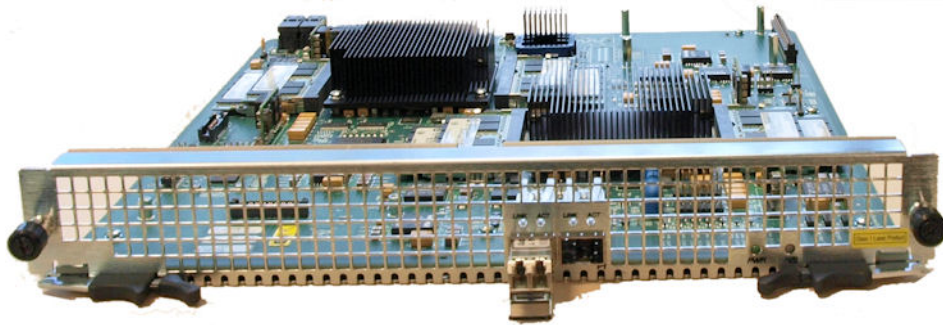

Installed SFP+ Transceiver

2. Flip the bale clasp latch back up and in to the rest position.

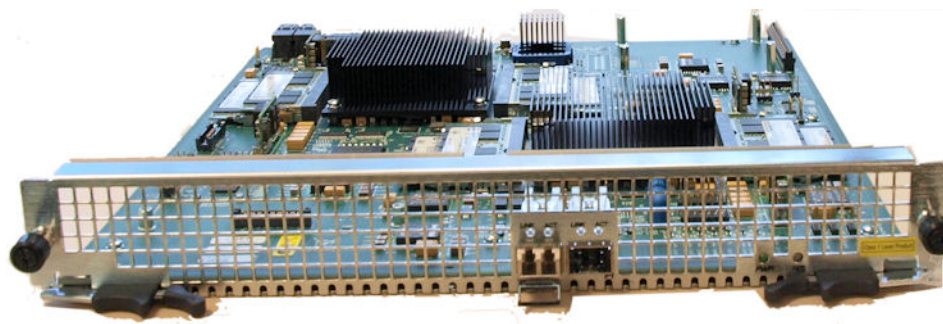

Sliding the SFP+ Transceiver Into the NIU

Alarms

The Acme Packet 6300/6350 generates internal alarms that correspond to internal hardware fault conditions. Hardware faults are divided into two types:

- Hardware and environmental
- Media link

Each alarm is assigned a severity level, depending on the details of the fault. Refer to the following table for information about these alarms.

Table 6-1 Alarm Severity Levels

Alarm Severity	Description
Minor	Functionality is impaired to a small degree (e.g., a single fan has failed).
Major	Pending failures or unexpected events are imminent (e.g., an LOS).
Critical	Catastrophic condition has occurred (e.g., the system is overheating).

The Acme Packet 6300/6350 polls its hardware components to ensure they are functioning properly. If it encounters a fault condition, it will report alarms in these categories:

- Hardware temperature
- Fan speed
- Environmental sensor
- Power supply
- Voltage
- Physical interface cards

For each category, the following tables list the Acme Packet 6300/6350 alarm name, hardware alarm ID, alarm severity, causes, log message, and graphic display window message, if any.

! Important:

If different sensors report two or more events of the same severity with the same Alarm ID, only the first alarm gets reported.

Hardware and Environmental Alarms

This section provides details about hardware and environmental alarms.

Hardware Temperature Alarm

The following table lists the hardware temperature alarm.

Table 6-2 Hardware Temperature Alarms

Alarm Name	Alarm Severity	Causes	Example Log Message	Graphic Display Window Message
------------	----------------	--------	---------------------	--------------------------------

Table 6-2 (Cont.) Hardware Temperature Alarms

SD5_TEMPERAT UR_HIGH_MAIN	CRITICAL: >100°C MAJOR: >95°C MINOR: >90°C	Fans are obstructed or stopped. The room is abnormally hot.	Temperature: XX.XXC (where XX.XX is the temperature in degrees)	Temperature X is at Y degrees C over minor/major/critical threshold of Z (Where X is sensor name, Y is temperature and Z is threshold)
SD5_TEMPERAT UR_HIGH_PHY0	CRITICAL: >100°C MAJOR: >95°C MINOR: >90°C	Fans are obstructed or stopped. The room is abnormally hot.	Temperature: XX.XXC (where XX.XX is the temperature in degrees)	Temperature X is at Y degrees C over minor/major/critical threshold of Z (Where X is sensor name, Y is temperature and Z is threshold)
SD5_TEMPERAT UR_HIGH_PHY1	CRITICAL: >100°C MAJOR: >95°C MINOR: >90°C	Fans are obstructed or stopped. The room is abnormally hot.	Temperature: XX.XXC (where XX.XX is the temperature in degrees)	Temperature X is at Y degrees C over minor/major/critical threshold of Z (Where X is sensor name, Y is temperature and Z is threshold)
SD5_TEMPERAT UR_HIGH_PHY2	CRITICAL: >100°C MAJOR: >95°C MINOR: >90°C	Fans are obstructed or stopped. The room is abnormally hot.	Temperature: XX.XXC (where XX.XX is the temperature in degrees)	Temperature X is at Y degrees C over minor/major/critical threshold of Z (Where X is sensor name, Y is temperature and Z is threshold)
SD5_TEMPERAT UR_HIGH_FLX1	CRITICAL: >100°C MAJOR: >95°C MINOR: >90°C	Fans are obstructed or stopped. The room is abnormally hot.	Temperature: XX.XXC (where XX.XX is the temperature in degrees)	Temperature X is at Y degrees C over minor/major/critical threshold of Z (Where X is sensor name, Y is temperature and Z is threshold)
SD5_TEMPERAT UR_HIGH_FLX2	CRITICAL: >100°C MAJOR: >95°C MINOR: >90°C	Fans are obstructed or stopped. The room is abnormally hot.	Temperature: XX.XXC (where XX.XX is the temperature in degrees)	Temperature X is at Y degrees C over minor/major/critical threshold of Z (Where X is sensor name, Y is temperature and Z is threshold)
SD5_TEMPERAT UR_HIGH_MGMT	CRITICAL: >100°C MAJOR: >95°C MINOR: >90°C	Fans are obstructed or stopped. The room is abnormally hot.	Temperature: XX.XXC (where XX.XX is the temperature in degrees)	Temperature X is at Y degrees C over minor/major/critical threshold of Z (Where X is sensor name, Y is temperature and Z is threshold)

Table 6-2 (Cont.) Hardware Temperature Alarms

SD5_TEMPERAT UR_HIGH_TLS0	CRITICAL: >100°C MAJOR: >95°C MINOR: >90°C	Fans are obstructed or stopped. The room is abnormally hot.	Temperature: XX.XXC (where XX.XX is the temperature in degrees)	Temperature X is at Y degrees C over minor/ major/critical threshold of Z (Where X is sensor name, Y is temperature and Z is threshold)
SD5_TEMPERAT UR_HIGH_TLS1	CRITICAL: >100°C MAJOR: >95°C MINOR: >90°C	Fans are obstructed or stopped. The room is abnormally hot.	Temperature: XX.XXC (where XX.XX is the temperature in degrees)	Temperature X is at Y degrees C over minor/ major/critical threshold of Z (Where X is sensor name, Y is temperature and Z is threshold)

Table 6-2 (Cont.) Hardware Temperature Alarms

SD5_TEMPERAT UR_HIGH_TLS2	CRITICAL: >100°C MAJOR: >95°C MINOR: >90°C	Fans are obstructed or stopped. The room is abnormally hot.	Temperature: XX.XXC (where XX.XX is the temperature in degrees)	Temperature X is at Y degrees C over minor/ major/critical threshold of Z (Where X is sensor name, Y is temperature and Z is threshold)
------------------------------	---	---	---	---



N

o

t

e

:

I

f

t

h

i

s

a

l

a

r

m

o

c

c

u

r

s

,

t

h

e

A

c

m

e

P

a

c

k

e

t

6

3

0

0

/

6

Table 6-2 (Cont.) Hardware Temperature Alarms

--

3
5
O
S
y
s
t
e
m
t
u
r
n
s
t
h
e
f
a
n
s
p
e
e
d
u
p
t
o
t
h
e
f
a
s
t
e
s
t
p
o
s
s
i
b
l
e
s
p
e
e
d
.

Fan Speed Alarm

The following table lists the fan speed alarm.

 **Note:**

There is one alarm for each fan on the Acme Packet 6300/6350. Each fan has its own alarm starting at SD5_FAN_UNDER_THRESHOLD_BASE, and has an offset of X where X is fan number (0-16, 5 alarms per slot and one fan on each power supply for a total of 17).

Table 6-3 Fan Speed Alarms

Alarm Name	Alarm Severity	Causes	Example Log Message	Graphic Display Window Message
SD5_FAN_UNDER_THRESHOLD_BASE+X (Where X is fan number)	CRITICAL: fan speed <25%. MINOR: fan speed <50%.	Fan failure.	Fan speed: TBD where TBD is the Revolutions per Minute (RPM) of each fan on the fan module	Fan X is at Y RPM, under critical/minor threshold of Z RPM (Where X is the fan name, Y is current speed and Z is threshold)

 **Note:**
If this alarm occurs, the A

Table 6-3 (Cont.) Fan Speed Alarms

The table content is currently blank.

c
m
e
P
a
c
k
e
t
6
3
0
0
/
6
3
5
0
S
y
s
t
e
m
t
u
r
n
s
t
h
e
f
a
n
s
p
e
e
d
u
p
t
o
t
h
e
f
a
s
t
e
s
t
p

Table 6-3 (Cont.) Fan Speed Alarms

Alarm	Alarm Severity	Causes	Log Message	Graphic Display Window Message
PLD FAN SPEED	MINOR	Fan speed is low.	Back Fan Speed is low!	N/A
PLD FAN SPEED UP	MINOR	Fan speed is now normal.	Back Fan Speed is normal!	N/A

o
s
s
i
b
l
e
s
p
e
e
d
.

Power Supply Alarms

The following table lists the power supply alarms.

Table 6-4 Power Supply Alarms

Alarm	Alarm Severity	Causes	Log Message	Graphic Display Window Message
PLD POWER A FAILURE	MINOR	Power supply A has failed.	Back Power Supply A has failed!	N/A
PLD POWER A UP	MINOR	Power supply A is now present and functioning.	Back Power Supply A is present!	N/A
PLD POWER B FAILURE	MINOR	Power supply B has failed.	Back Power Supply B has failed!	N/A
PLD POWER B UP	MINOR	Power supply B is now present and functioning.	Back Power Supply B is present!	N/A

Voltage Alarms

The following table lists the voltage alarms.

Table 6-5 Voltage Alarms

Alarm	Alarm Severity	Cause(s)	Log Message	Graphic Display Window Message
SD5_VOLTAGE_HIGH_MAIN	EMERGENCY outside 30% of normal voltage MINOR: outside 10% of normal voltage	Faulty POL that is not operating correctly	Voltage: XX.XXV (Where XX.XX is the voltage in volts)	POL X is at Y volts, outside minor/emergency threshold of Z1 to Z2 (Where X is sensor name, Y is voltage and Z is threshold)
SD5_VOLTAGE_HIGH_PHY0	EMERGENCY outside 30% of normal voltage MINOR: outside 10% of normal voltage	Faulty POL that is not operating correctly	Voltage: XX.XXV (Where XX.XX is the voltage in volts)	POL X is at Y volts, outside minor/emergency threshold of Z1 to Z2 (Where X is sensor name, Y is voltage and Z is threshold)
SD5_VOLTAGE_HIGH_PHY1	EMERGENCY outside 30% of normal voltage MINOR: outside 10% of normal voltage	Faulty POL that is not operating correctly	Voltage: XX.XXV (Where XX.XX is the voltage in volts)	POL X is at Y volts, outside minor/emergency threshold of Z1 to Z2 (Where X is sensor name, Y is voltage and Z is threshold)
SD5_VOLTAGE_HIGH_PHY2	EMERGENCY outside 30% of normal voltage MINOR: outside 10% of normal voltage	Faulty POL that is not operating correctly	Voltage: XX.XXV (Where XX.XX is the voltage in volts)	POL X is at Y volts, outside minor/emergency threshold of Z1 to Z2 (Where X is sensor name, Y is voltage and Z is threshold)
SD5_VOLTAGE_HIGH_FLUX1	EMERGENCY outside 30% of normal voltage MINOR: outside 10% of normal voltage	Faulty POL that is not operating correctly	Voltage: XX.XXV (Where XX.XX is the voltage in volts)	POL X is at Y volts, outside minor/emergency threshold of Z1 to Z2 (Where X is sensor name, Y is voltage and Z is threshold)

Table 6-5 (Cont.) Voltage Alarms

Alarm	Alarm Severity	Cause(s)	Log Message	Graphic Display Window Message
SD5_VOLTA GE_HIGH_FL EX2	EMERGENCY outside 30% of normal voltage MINOR: outside 10% of normal voltage	Faulty POL that is not operating correctly	Voltage: XX.XXV (Where XX.XX is the voltage in volts)	POL X is at Y volts, outside minor/ emergency threshold of Z1 to Z2 (Where X is sensor name, Y is voltage and Z is threshold)
SD5_VOLTA GE_HIGH_M GMT	EMERGENCY outside 30% of normal voltage MINOR: outside 10% of normal voltage	Faulty POL that is not operating correctly	Voltage: XX.XXV (Where XX.XX is the voltage in volts)	POL X is at Y volts, outside minor/ emergency threshold of Z1 to Z2 (Where X is sensor name, Y is voltage and Z is threshold)
SD5_VOLTA GE_HIGH_TL S0	EMERGENCY outside 30% of normal voltage MINOR: outside 10% of normal voltage	Faulty POL that is not operating correctly	Voltage: XX.XXV (Where XX.XX is the voltage in volts)	POL X is at Y volts, outside minor/ emergency threshold of Z1 to Z2 (Where X is sensor name, Y is voltage and Z is threshold)
SD5_VOLTA GE_HIGH_TL S1	EMERGENCY outside 30% of normal voltage MINOR: outside 10% of normal voltage	Faulty POL that is not operating correctly	Voltage: XX.XXV (Where XX.XX is the voltage in volts)	POL X is at Y volts, outside minor/ emergency threshold of Z1 to Z2 (Where X is sensor name, Y is voltage and Z is threshold)
SD5_VOLTA GE_HIGH_TL S2	EMERGENCY outside 30% of normal voltage MINOR: outside 10% of normal voltage	Faulty POL that is not operating correctly	Voltage: XX.XXV (Where XX.XX is the voltage in volts)	POL X is at Y volts, outside minor/ emergency threshold of Z1 to Z2 (Where X is sensor name, Y is voltage and Z is threshold)

Link and SDP Alarms

Link alarms are generated when a network cable is plugged into or unplugged from a configured network interface. For each possible network interface, an alarm exists that indicates whether the link goes up or down.

The following tables list detailed information about the Acme Packet 6300/6350 System's NIU link alarms, including their ID assignments, severities, causes, log messages, and messages printed in the graphic display window.

Media Ethernet Link Alarms

The following table lists the NIU 10GbE interface link up/link down alarms.

Table 6-6 Media Ethernet Link Alarms

Alarm Name	Alarm Severity	Cause(s)	Example Log Message	Graphic Display Message
LINK UP ALARM GIGPORT	MINOR	10GbE S0P0 link up	Slot 0 port 0 UP	X LINK ALARMS (where X is number of alarming links)
LINK UP ALARM GIGPORT	MINOR	10GbE S1P0 link up	Slot 1 port 0 UP	X LINK ALARMS
LINK UP ALARM GIGPORT	MINOR	10GbE S2P0 link up	Slot 2 port 0 UP	XLINK ALARMS
LINK DOWN ALARM GIGPORT	MAJOR	10GbE S0P0 link down	Slot 0 port 0 DOWN	X LINK ALARMS
LINK DOWN ALARM GIGPORT	MAJOR	10GbE S1P0 link down	Slot 1 port 0 DOWN	X LINK ALARMS
LINK DOWN ALARM GIGPORT	MAJOR	10GbE S2P0 link down	Slot 2 port 0 DOWN	X LINK ALARMS
LINK UP ALARM GIGPORT	MINOR	10GbE S0P1 link up	Slot 0 port 1 UP	X LINK ALARMS
LINK UP ALARM GIGPORT	MINOR	10GbE S1P1 link up	Slot 1 port 1 UP	X LINK ALARMS
LINK UP ALARM GIGPORT	MINOR	10GbE S2P1 link up	Slot 2 port 1 UP	X LINK ALARMS
LINK DOWN ALARM GIGPORT	MAJOR	10GbE S0P1 link down	Slot 0 port 1 DOWN	X LINK ALARMS
LINK DOWN ALARM GIGPORT	MAJOR	10GbE S1P1 link down	Slot 1 port 1 DOWN	X LINK ALARMS
LINK DOWN ALARM GIGPORT	MAJOR	10GbE S2P1 link down	Slot 2 port 1 DOWN	X LINK ALARMS

Management Ethernet Link Alarms

The following table lists the NIU management Ethernet port alarms:

Table 6-7 Management Ethernet Link Alarms

Alarm Name	Alarm Severity	Cause(s)	Example Log Message	Graphic Display Message
LINK UP ALARM VXINTF	MINOR	Mgmt0 link up	Port 0 UP	X LINK ALARMS (where X is number of alarming links)
LINK UP ALARM VXINTF	MINOR	Mgmt1 link up	Port 1 UP	X LINK ALARMS
LINK UP ALARM VXINTF	MINOR	Mgmt2 link up	Port 2 UP	X LINK ALARMS
LINK DOWN ALARM VXINTF	MAJOR	Mgmt0 link down	Port 0 DOWN	X LINK ALARMS
LINK DOWN ALARM VXINTF	MAJOR	Mgmt1 link down	Port 1 DOWN	X LINK ALARMS
LINK DOWN ALARM VXINTF	MAJOR	Mgmt2 link down	Port 2 DOWN	X LINK ALARMS

SFP+ Presence Alarms

The following table lists the alarms that reflect when an SFP+ module is inserted or removed from an NIU:

Table 6-8 SFP+ Presence Alarms

Alarm Name	Alarm Severity	Cause(s)	Example Log Message	Graphic Display Message
SFP+ REMOVED GIGPORT 0	CRITICAL	S0P0 SFP+ Removed	Slot 0 Port 0 SFP+ Removed	N/A
SFP+ INSERTED GIGPORT 0	CRITICAL	S0P0 SFP+ Inserted	Slot 0 Port 0 SFP+ Inserted	N/A
SFP+ REMOVED GIGPORT 1	CRITICAL	S1P0 SFP+ Removed	Slot 1 Port 0 SFP+ Removed	N/A
SFP+ INSERTED GIGPORT 1	CRITICAL	S1P0 SFP+ Inserted	Slot 1 Port 0 SFP+ Inserted	N/A
SFP+ REMOVED GIGPORT 2	CRITICAL	S0P1 SFP+ Removed	Slot 0 Port 1 SFP+ Removed	N/A
SFP+ INSERTED GIGPORT 2	CRITICAL	S0P1 SFP+ Inserted	Slot 0 Port 1 SFP+ Inserted	N/A
SFP+ REMOVED GIGPORT 3	CRITICAL	S1P1 SFP+ Removed	Slot 1 Port 1 SFP+ Removed	N/A
SFP+ INSERTED GIGPORT 3	CRITICAL	S1P1 SFP+ Inserted	Slot 1 Port 1 SFP+ Inserted	N/A
SFP+ REMOVED GIGPORT 4	CRITICAL	S2P0 SFP+ Removed	Slot 2 Port 0 SFP+ Removed	N/A
SFP+ INSERTED GIGPORT 4	CRITICAL	S2P0 SFP+ Removed	Slot 2 Port 0 SFP+ Removed	N/A

Table 6-8 (Cont.) SFP+ Presence Alarms

SFP+ INSERTED GIGPORT 5	CRITICAL	S2P1 SFP+ Removed	Slot 2 Port 1 SFP+ Removed	N/A
SFP+ REMOVED GIGPORT 5	CRITICAL	S2P1 SFP+ Removed	Slot 2 Port 1 SFP+ Removed	N/A

When an SFP+ module is inserted or removed from an NIU, there is no impact on system health.

7

Specifications

This chapter provides information regarding the physical, electrical, environmental, and connector specifications of the Acme Packet 6300/6350.

Environmental, Safety, and Regulatory Certifications

For information regarding safety and regulatory certifications applicable to the Acme Packet 6300/6350, refer to the Acme Packet Platforms Safety and Compliance Guide.

Physical Specifications

Acme Packet 6300/6350 System Chassis Specifications

Table 7-1 Acme Packet 6300/6350 Physical Specifications

Specification	Description
Height	5.22" (13.26 cm) (3U)
Width	17.10" (43.43 cm) (+ mounting ear width: 19" (48.26 cm))
Depth	20" (50.8 cm)
Weight	approximately 42.5 lbs (19.27 kg), fully loaded

AC Power Supply Physical Dimensions

Table 7-2 Acme Packet 6300/6350 Physical Dimensions

Specification	Description
Height	1.575" (4.0 cm)
Width	2.146" (5.45 cm)
Depth	13.26" (33.68 cm)
Weight	2lbs., 5oz. (1.05 kg)

Important: This equipment is intended for installation in locations where the National Electrical Code (NEC) applies.

DC Power Supply Physical Dimensions

Table 7-3 Acme Packet 6300/6350 DC Power Supply Physical Dimensions (continued)

Specification	Description
Height	1.575" (4.0 cm)

Table 7-3 (Cont.) Acme Packet 6300/6350 DC Power Supply Physical Dimensions (continued)

Specification	Description
Width	2.146" (5.45 cm)
Depth	13.26" (33.68 cm)
Weight	2lbs., 0 oz. (1.05 kg)

Important: This equipment is intended for installation in Network Telecommunication Facilities.

Fan Module Specifications

Table 7-4 Acme Packet 6300/6350 Fan Module Specifications

Specification	Description
Number of Fans	15
Total Maximum Airflow	300 CFM

Electrical Specifications

Refer to the following tables for information regarding the electrical specifications of the Acme Packet 6300/6350.

Power Supply Input Circuit Fuse Requirements

Table 7-5 Acme Packet 6300/6350 Power Supply Input Circuit Fuse Requirements

Power Circuit	Fuse Rating	Power cable size
120 VAC	15 AMP	18 AWG
240 VAC	7.5 AMP	18 AWG
-48 VDC	35 AMP min	10 AWG

Alarm Port Dry Contact Current Limits

Table 7-6 Acme Packet 6300/6350 Alarm Port Dry Contact Current Limits

Specification	Value
Max AC switching current	0.3 A @ 125 VAC
Max DC switching current	1 A @ 30 VDC

Environmental Specifications

For the Acme Packet 6300/6350 to function properly, Acme Packet recommends that you follow the environmental guidelines in the following table.

Table 7-7 Acme Packet 6300/6350 Environmental Specifications

Specification	Description
Temperature	The Acme Packet 6300/6350 System is required to operate within the temperature range of: * +0° C to +40° C, 32° F to 104° F (operating) * -20° C to +65° C, -4° F to 149° F (storage)
Relative Humidity	Operating conditions of 10% to 85% humidity under non-condensing operating conditions
Maximum Altitude	The Acme Packet 6300/6350 System is required to operate below the maximum altitude of 10,000 feet.
Air Flow	300 CFM
Power Dissipation	250W typical 350W maximum (base system with 2x10 G NIU) Additional 150W for second 2 x 10GbE NIU Additional 275W for each fully populated transcode carrier card

Connector Specifications

Refer to the following table for information about the connector specifications for the Acme Packet 6300/6350.

Table 7-8 Acme Packet 6300/6350

Specification	Description
RJ45/Management Ethernet Ports	The 3 x 8-pin RJ45 10/100/1000BaseT Ethernet ports are compliant with IEEE's 802.3, 802.3u, and 802.3ab.
RJ45/Alarm Contact Port	Any alarms generated by the system are accessible via the 8-pin RJ45 alarm contact port.
RS232/Serial Port	The RS232 serial port uses an 8-pin RJ45 connector that supports RS232-C protocol.
10GbE Port(s)	The 10GbE fiber optic connection ports use duplex LC connectors.
IEC Connector Ports	The IEC connector ports accept a 3-lead IEC-320 connector for AC power installations.

Optical Transceiver Interface Module Specification

Refer to the following table for information about the optical specifications of the 10GbE SFP+ optical transceivers for the Acme Packet 6300/6350.

Table 7-9 (continued) Acme Packet 6300/6350 Optical Transceiver Interface Module Specifications

Specification	Multimode (SX) Fiber Module	Singlemode (LX) Fiber Module
Wavelength λ	850 nm	1310 nm
Laser Type	VCSEL	DFB
Fiber type / Transmission Distance	-0.5 to 550 m -50 μ m -0.5 to 550 m -62.5 μ m	-0.5 m to 10 km

8

Acronyms, Definitions, and Terms

ACLI

Acme Command Line Interface is the command line interface used by Oracle to configure, maintain, and monitor SBCs and other Oracle products.

AC

Alternating Current refers to the 120-volt electricity delivered by power utilities to three-pin power outlets. This type of power is called alternating current because the polarity of the current alternates between plus and minus, 60 times per second.

AWG

American Wire Gauge is a United States standard set of non-ferrous wire conductor sizes. The gauge means the diameter.

BTU

British Thermal Unit

CSA

Canadian Standards Association is a non-profit, independent organization that operates a listing service for electrical and electronic materials and equipment.

DC

Direct Current refers to the flow of electrons in one direction within an electrical conductor, such as a wire.

EMC

Electromagnetic Compatibility is the ability of equipment or systems to be used in their intended environment within designed efficiency levels without causing or receiving degradation due to unintentional electromagnetic interference.

ESD

Electrostatic Discharge is the rapid discharge of static electricity from one conductor with an electrical charge to another of a different electrical charge.

CE

European Compliance

EN

European Norm

FCC

Federal Communications Commission

FG

Frame ground

flash memory

Flash memory is a solid-state, non-volatile, re-writable memory that functions like a combination of RAM and a hard disk drive.

FQME

Flow Quality Measurement Engine is responsible for monitoring, measuring, and maintaining statistics (e.g., latency, jitter, flow stoppage, flow creation, etc.) on a flow-by-flow basis.

10GbE

Gigabit Ethernet is an Ethernet type that supports data transfer rates of 10 gigabit per second.

IEEE

Institute of Electrical and Electronics Engineers is an organization composed of engineers, scientists, and students. The IEEE is best known for developing standards for the computer and electronics industry.

ICES

Interference-causing Equipment Standard

IEC

International Electrotechnical Commission

IETF

Internet Engineering Task Force is the main standards organization for the Internet.

IP

Internet Protocol is the method by which data is sent from one computer to another on the Internet.

LED

Light Emitting Diode is an electronic device that lights up when electricity is passed through it.

LAN

Local Area Network is a group of computers and associated devices that share a common communications line within a small geographic area.

LOS

Loss of Signal occurs when the signal level falls below an acceptable level. LOS is a physical layer error and typically results in an alarm.

NEBS

Network Equipment Building Standards defines a rigid and extensive set of performance, quality, environmental, and safety requirements developed by Bellcore.

NIC

Network Interface Card is an expansion board you insert into a computer so the computer can be connected to a network.

NIU

The NIU provides network connectivity for management, signaling, and media traffic to and from the Acme Packet 6300 System.

NVRAM

Non-volatile Random Access Memory is a type of memory that retains its contents when power is turned off.

optical transceiver

The fiber connection to the Acme Packet 6300 System plugs into an optical transceiver. Through this connection, light energy is converted into electrical energy.

PCMCIA

Personal Computer Memory Card International Association is an organization consisting of approximately 500 companies that has developed a standard for small, credit-card sized devices (PC cards). This standard is designed for attaching input/output devices such as network adaptors, fax/modems, or hard drives to notebook computers.

physical interface card

The physical interface card is synonymous with the network interface cards on the Acme Packet 6300 System.

PROM

Programmable Read-only Memory is a memory chip on which data can only be written once. A PROM is non-volatile; it is a memory chip on which data can be written only once.

QoS

Quality of Service is a networking term that refers to the capability of a network to provide better service to selected network traffic over various technologies.

RAM

Random Access Memory is a type of computer memory that can be accessed randomly. RAM is the same as main memory.

RS-232

Recommended Standard 232 is a standard interface approved by the Electronic Industries Association for connecting serial devices.

RJ45

Registered Jack 45 is an eight-wire connector commonly used to connect computers onto a LAN.

SNMP

Simple Network Management Protocol is a set of protocols used for managing complex networks and network devices.

SDRAM

Synchronous Dynamic Random Access Memory is a type of DRAM that can run at much higher clock speeds than conventional memory.

Telnet

Telnet is a standard terminal emulation program that allows remote login and connection to systems/servers on a network. Telnet uses a single TCP/IP network connection to provide this remote login, control, and communication functionality.

TCP

Transmission Control Protocol provides a reliable stream delivery and virtual connection service to applications through the use of sequenced acknowledgment with the retransmission of packets when necessary.

TCU

Transcoding Carrier Unit.

UPS

Uninterruptible Power Supply is a power supply that can run off of a backup battery when primary power is lost.

UDP

User Datagram Protocol provides a simple, but unreliable message service for transaction-oriented services. Each UDP header carries both a source port identifier and a destination port identifier, allowing high-level protocols to target specific applications and services among hosts.

VFD

Vacuum Fluorescent Display is used on the graphic display window of the Acme Packet 6300 System chassis's front control panel.

VLAN

Virtual Local Area Network refers to a network of computers are connected to a single physical segment of a wire but behave as if they are connected to the physically diverse LANs.

VAC

Volts Alternating Current

VDC

Volts Direct Current

VCCI

Voluntary Control Council for Information Technology Equipment (Japan)

WAN

Wide Area Network is a computer network that spans a relatively large geographical area. Typically, a WAN consists of two or more LANs.

WEEE

The directive by the European Parliament and the Council of the European Union 2002/96/EC concerning waste electrical and electronic equipment (WEEE).