

Oracle® Communications

EAGLE Application B Card Hardware and Installation Guide



Release 18.0

G58026-01

June 2026

The Oracle logo, consisting of a solid red square with the word "ORACLE" in white, uppercase, sans-serif font centered within it.

ORACLE®

Copyright © 1993, 2026, Oracle and/or its affiliates.

This software and related documentation are provided under a license agreement containing restrictions on use and disclosure and are protected by intellectual property laws. Except as expressly permitted in your license agreement or allowed by law, you may not use, copy, reproduce, translate, broadcast, modify, license, transmit, distribute, exhibit, perform, publish, or display any part, in any form, or by any means. Reverse engineering, disassembly, or decompilation of this software, unless required by law for interoperability, is prohibited.

The information contained herein is subject to change without notice and is not warranted to be error-free. If you find any errors, please report them to us in writing.

If this is software, software documentation, data (as defined in the Federal Acquisition Regulation), or related documentation that is delivered to the U.S. Government or anyone licensing it on behalf of the U.S. Government, then the following notice is applicable:

U.S. GOVERNMENT END USERS: Oracle programs (including any operating system, integrated software, any programs embedded, installed, or activated on delivered hardware, and modifications of such programs) and Oracle computer documentation or other Oracle data delivered to or accessed by U.S. Government end users are "commercial computer software," "commercial computer software documentation," or "limited rights data" pursuant to the applicable Federal Acquisition Regulation and agency-specific supplemental regulations. As such, the use, reproduction, duplication, release, display, disclosure, modification, preparation of derivative works, and/or adaptation of i) Oracle programs (including any operating system, integrated software, any programs embedded, installed, or activated on delivered hardware, and modifications of such programs), ii) Oracle computer documentation and/or iii) other Oracle data, is subject to the rights and limitations specified in the license contained in the applicable contract. The terms governing the U.S. Government's use of Oracle cloud services are defined by the applicable contract for such services. No other rights are granted to the U.S. Government.

This software or hardware is developed for general use in a variety of information management applications. It is not developed or intended for use in any inherently dangerous applications, including applications that may create a risk of personal injury. If you use this software or hardware in dangerous applications, then you shall be responsible to take all appropriate fail-safe, backup, redundancy, and other measures to ensure its safe use. Oracle Corporation and its affiliates disclaim any liability for any damages caused by use of this software or hardware in dangerous applications.

Oracle®, Java, MySQL, and NetSuite are registered trademarks of Oracle and/or its affiliates. Other names may be trademarks of their respective owners.

Intel and Intel Inside are trademarks or registered trademarks of Intel Corporation. All SPARC trademarks are used under license and are trademarks or registered trademarks of SPARC International, Inc. AMD, Epyc, and the AMD logo are trademarks or registered trademarks of Advanced Micro Devices. UNIX is a registered trademark of The Open Group.

This software or hardware and documentation may provide access to or information about content, products, and services from third parties. Oracle Corporation and its affiliates are not responsible for and expressly disclaim all warranties of any kind with respect to third-party content, products, and services unless otherwise set forth in an applicable agreement between you and Oracle. Oracle Corporation and its affiliates will not be responsible for any loss, costs, or damages incurred due to your access to or use of third-party content, products, or services, except as set forth in an applicable agreement between you and Oracle.

For information about Oracle's commitment to accessibility, visit the Oracle Accessibility Program website at <http://www.oracle.com/pls/topic/lookup?ctx=acc&id=docacc>.

Oracle customer access to and use of Oracle support services will be pursuant to the terms and conditions specified in their Oracle order for the applicable services.

Contents

| | | |
|----------|---|---|
| 1 | Introduction | |
| | Overview | 1 |
| | Scope and Audience | 1 |
| | References | 1 |
| | Applications Documents and Related Specifications | 1 |
| | Locate Product Documentation on the Oracle Help Center Site | 2 |
| | Locating E5-APP-B Card Part Numbers | 2 |
| | Locating E5-APP-B Card Part Number Information | 2 |
| | Locating Drive Module Assembly Part Number Information | 3 |
| 2 | Safety and Pre-Installation Requirements | |
| | Introduction | 1 |
| | Safety Information | 1 |
| | Regulatory Compliance and Certification | 3 |
| | Pre-Installation Site Requirements | 5 |
| | Generic Site Requirements | 5 |
| | Grounding and Power Requirements | 7 |
| 3 | E5-APP-B Card Overview | |
| | Introduction | 1 |
| | E5-APP-B Card | 1 |
| | E5-APP-B Card Features | 2 |
| | E5-APP-B Card Components | 5 |
| | E5-APP-B Card Interfaces | 5 |
| | Electrical Features | 5 |
| | Mechanical Design and Maintenance Features | 6 |
| | E5-APP-B Card Diagnostics | 6 |
| 4 | Installing and Removing E5-APP-B Cards | |
| | Introduction | 1 |
| | Provisioning Rules for E5-APP-B Cards | 1 |

| | |
|--------------------------------------|---|
| E5-APP-B Fan Alarms | 2 |
| IMT Bus | 2 |
| E5-APP-B Power Guidelines | 2 |
| Obtaining the EAGLE Power Calculator | 2 |
| E5-APP-B Card Distance Limitations | 3 |
| Installing an E5-APP-B Card | 3 |
| Removing an E5-APP-B Card | 7 |
| E5-APP-B Card Adapter Interfaces | 8 |
| Changing Passwords | 9 |

A ExAP or LSMS Network Integration

| | |
|--|------|
| Introduction | A-1 |
| Network Overview | A-1 |
| Customer-Supplied Information | A-9 |
| Network Configuration | A-9 |
| Firewall and Router Filtering Considerations | A-10 |

B IMF Network Integration

| | |
|------------------|-----|
| Introduction | B-1 |
| Network Overview | B-1 |

My Oracle Support (MOS)

[My Oracle Support \(MOS\)](#) is your initial point of contact for any of the following requirements:

- **Product Support:**
The generic product related information and resolution of product related queries.
- **Critical Situations**
A critical situation is defined as a problem with the installed equipment that severely affects service, traffic, or maintenance capabilities, and requires immediate corrective action. Critical situations affect service and/or system operation resulting in one or several of these situations:
 - A total system failure that results in loss of all transaction processing capability
 - Significant reduction in system capacity or traffic handling capability
 - Loss of the system's ability to perform automatic system reconfiguration
 - Inability to restart a processor or the system
 - Corruption of system databases that requires service affecting corrective actions
 - Loss of access for maintenance or recovery operations
 - Loss of the system ability to provide any required critical or major trouble notificationAny other problem severely affecting service, capacity/traffic, billing, and maintenance capabilities may be defined as critical by prior discussion and agreement with Oracle.
- **Training Need**
Oracle University offers training for service providers and enterprises.

My Oracle Support (<https://support.oracle.com>) is your initial point of contact for all product support and training needs. A representative at Customer Access Support can assist you with My Oracle Support registration.

Call the Customer Access Support main number at 1-800-223-1711 (toll-free in the US), or call the Oracle Support hotline for your local country from the list at <http://www.oracle.com/us/support/contact/index.html>. When calling, make the selections in the sequence shown below on the Support telephone menu:

- For Technical issues such as creating a new Service Request (SR), select **1**.
- For Non-technical issues such as registration or assistance with My Oracle Support, select **2**.
- For Hardware, Networking and Solaris Operating System Support, select **3**.

You are connected to a live agent who can assist you with My Oracle Support registration and opening a support ticket.

My Oracle Support is available 24 hours a day, 7 days a week, 365 days a year.

Acronyms

The following table provides information about the acronyms and the terminology used in the document.

Table Acronyms

| Acronym | Definition |
|----------------|-----------------------------------|
| AWG | American Wire Gauge |
| DC | Direct Current |
| FRU | Field Replaceable Unit |
| GUI | Graphical User Interface |
| LED | Light Emitting Diode |
| LSMS | Local Service Management System |
| MPS | Multi Purpose Server |
| MTBF | Mean Time Between Failures |
| NEBS | Network Equipment Building System |
| SM | Service Module |
| STP | Signal Transfer Point |
| USB | Universal Serial Bus |

What's New in This Guide

This section introduces the documentation updates for Release 18.0 in Oracle Communications EAGLE Application Processor Application B Card Hardware and Installation Guide.

Release 18.0 - G58026-01, June 2026

There are no updates in this document in this release.

1

Introduction

This chapter provides a brief overview of the Oracle Communications EAGLE Application B Card (E5-APP-B). This chapter also includes the scope, audience, and organization of this manual; how to find related publications; and how to contact the [My Oracle Support \(MOS\)](#).

Overview

The Oracle Communications EAGLE Application B Card (E5-APP-B) is a complete application server platform designed to operate within a heavy duty EAGLE shelf. An E5-APP-B card consists of the card, a microprocessor, 8 GB RAM, and two removable drive modules with an operating system and an application, such as EPAP, loaded.

Note

This guide includes links to documents that are specific to a given product. For more information about linked documents, see [guide](#).

Each time this guide is published, the revision level is changed. For example, the first time this guide is published, it uses Revision 1; the second time it is published, it uses Revision 2.

Scope and Audience

The scope of this manual includes Oracle Communications EAGLE Application B Card hardware installation and removal procedures. This manual also contains network integration information for ExAP, LSMS and IMF.

References

For more information, refer to the following documents:

- *ELAP Administration and LNP Feature Activation Guide*
- *EPAP Administration Guide*
- *TPD Initial Product Manufacture User's Guide*

Applications Documents and Related Specifications

The E5-APP-B card supports a variety of applications. For information about additional publications that are related to this document, refer to the Oracle Help Center site. See [Locate Product Documentation on the Oracle Help Center Site](#) for more information on related product publications.

Note

Application documentation may also contain information about additional hardware.

Locate Product Documentation on the Oracle Help Center Site

Oracle Communications customer documentation is available on the web at the Oracle Help Center (OHC) site, <http://docs.oracle.com>. You do not have to register to access these documents. Viewing these files requires Adobe Acrobat Reader, which can be downloaded at <http://www.adobe.com>.

1. Access the Oracle Help Center site at <http://docs.oracle.com>.
2. Click **Industries**.
3. Under the Oracle Communications subheading, click the **Oracle Communications documentation link**.

The Communications Documentation page appears. Most products covered by these documentation sets appears under the headings, **Signaling & Policy > EAGLE**.

4. Click on your Product and then the Release Number.
A list of the entire documentation set for the selected product and release appears.
5. To download a file to your location, right-click the **PDF** link, select **Save target as** (or similar command based on your browser), and save to a local folder.

Locating E5-APP-B Card Part Numbers

Each **E5-APP-B** card **FRU** has labels that contain the following information that may be needed for the **RMA**:

- Part number (to identify the type of **FRU**)
- Serial number (to provide more information about the specific **FRU**)
- **CLEI** (Common Language Equipment Identifier, a label that identifies the manufacturer and the part)

In addition to part numbers on each **FRU**, the **E5-APP-B** card has several labels that contain part number information for drive module **FRUs** on the E5-APP-B card. These labels allow part number information to be gathered without removing the E5-APP-B card.

To locate the part number information, use the indicated procedure below:

- **E5-APP-B** card, use [Locating E5-APP-B Card Part Number Information](#)
- Drive module assembly, use [Locating Drive Module Assembly Part Number Information](#)

Locating E5-APP-B Card Part Number Information

The part number information for the **E5-APP-B** card is located on the label on the faceplate of the E5-APP-B card. Use this label to verify the correct part number if you ever need to replace the E5-APP-B card.

1. Request assistance from [My Oracle Support \(MOS\)](#) to determine which slot (1 through 17) contains the **E5-APP-B** card that needs to be replaced.

2. See [Locating Drive Module Assembly Part Number Information](#) for the location information of each **E5-APP-B** card on the label.

ⓘ warning

Always wear an **ESD** wrist strap grounded to the bench or frame when working on electronic components.

Locating Drive Module Assembly Part Number Information

The part number information for drive module assemblies is located on the label on the drive module assembly. Use this label to verify the correct part number if you ever need to replace a drive module assembly. See [Figure 1-1](#).

Figure 1-1 E5-APP-B Card Label Locations

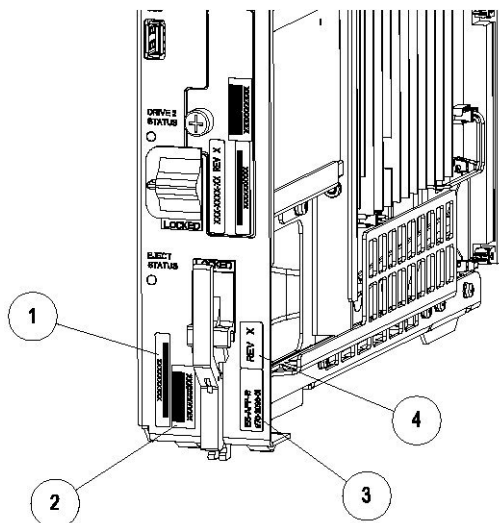

- Serial Number Label (1)
 - CLEI Label (2)
 - Part Number Label (3)
 - Revision Label (4)
1. Request that [My Oracle Support \(MOS\)](#) assist you in determining whether the drive module assembly that needs to be replaced is in drive A or drive B.
 2. Find the part number information on the drive module. See [Figure 1-2](#) for illustration.

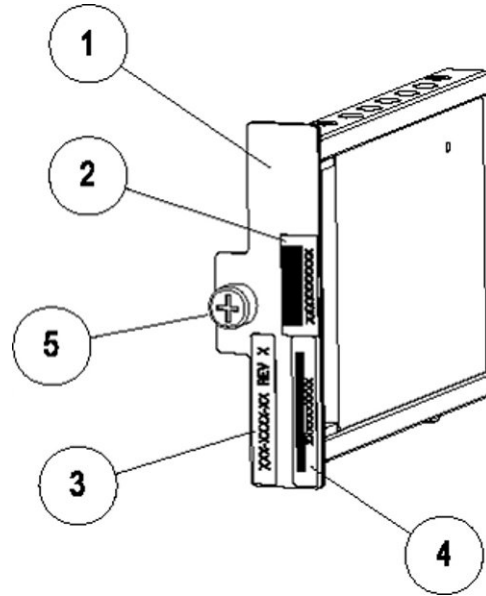
Figure 1-2 Drive Module Label Locations

- Drive module Assembly (1)
- CLEI Label (2)
- Part Number and Revision Label (3)
- Serial Number Label (4)
- Locking Screw (5)

ⓘ warning

Always wear an **ESD** wrist strap grounded to the bench or frame when working on electronic components.

3. Report the requested part number information on the drive module label.

2

Safety and Pre-Installation Requirements

This chapter lists general safety instructions that readers should be familiar with and site requirements that should be verified before installing Oracle Communications E5-APP-B cards into an EAGLE shelf.

Introduction

This chapter presents general safety considerations to be kept in mind when installing or replacing Oracle Communications products, a listing of regulatory compliance statements and certifications that Oracle Communications products support, and site requirements for installing Oracle Communications products.

Safety Information

Safety icons and text are used throughout Oracle Communications guides to warn the reader of the potential of personal injury, service interruption, and equipment damage.

Before beginning any procedure described in this guide, ensure that you are familiar with each of the following safety admonishments. Additional safety admonishments may be included, or repeated, for specific procedures.

topple

Always read and understand instructions completely before working on, moving, raising or lowering the frame, any portion of the frame, or attachments to the frame or equipment.

topple

Never try to unpack any frame from the shipping container without at least two people to steady any movement of the frame and related components. At least two people are required to safely move and position any frame.

topple

Never pull out the shelf of any frame that is not anchored properly. Some frames are required to be attached to overhead ladder racks before shelves are extended.

NOT_SUPPORTED

No commercially **AC** powered equipment may be used or placed within 7 ft. of –48V equipment. **AC** powered equipment within 7 ft. of –48V equipment may create a shock or current loop that can be severely hazardous to personnel and equipment.

NOT_SUPPORTED

Do not wear metal, chains, rings, watches, or jewelry or carry exposed metal, keys or tools in pockets when working on system equipment or other related electrostatic-sensitive components. Always wear a wrist strap or other electrostatic protection when handling printed circuit boards and other electrostatic-sensitive devices.

 **warning**

Do not leave or allow unused metal objects, such as screws or washers, to remain anywhere within the equipment. Remove all unused material from the equipment

 **warning**

Do not allow any metal shavings to remain in the equipment area. Metal Shavings may result from over tightened screws or bolts. These small metal particles are hazardous to electronic equipment. Be careful not to over tighten screws or bolts.

 **warning**

Do not use tie wraps on or above the top traverse arms on a frame. Always trim tie wrap flush and turn the trimmed tie wrap to the rear of the cable.

 **Caution**

All personnel associated with the installation of these systems must adhere to all safety precautions and use required protection equipment, to avoid the possibility of injury to personnel, service degradation, and/or service interruption.

 **Caution**

These systems have redundant power supplies to allow service during normal maintenance. When repairs require a total power disconnect, both input supply sources must be disconnected. This causes service interruption and takes down the systems.

 **Caution**

This equipment has a connection between the earthed conductor of the **DC** supply circuit and the earthing conductor.

 **Caution**

The Branch Circuit Overcurrent Protection shall be rated minimum -48V, maximum 60A.

 **Caution**

Equipment is to be installed in restricted access areas in accordance with articles 110-16, 110-17, and 110-18 of the National Electric Code, **ANSI/NFPA 70**.

 **Caution**

A readily accessible disconnect device that is suitable, approved, and rated shall be incorporated in the field wiring.

 **Caution**

Connect to a reliably grounded **SELV** source which is reliably earthed and electrically isolated from the **AC** source.

 **Caution**

Use only listed closed loop connectors for connection to the supply.

 **Note**

Use a minimum of 26 AWG telecommunications line cord for connection to the modem.

Regulatory Compliance and Certification

Oracle Communications products are tested to meet the following regulatory standards:

- Network Equipment Building System (NEBS) level 3 as listed in Telcordia SR-3580.
- Applicable Telcordia Electromagnetic Compatibility and Electrical Safety requirements in GR-1089-CORE.
- Applicable Physical Protection requirements in GR-63-CORE.

- Relevant directives and harmonized standards in support of the products Compliance European (CE) mark required in Europe. [Figure 2-1](#) shows the mark used to indicate this compliance.

Figure 2-1 European Directives CE Mark



- Relevant standards in ElectroMagnetic Compatibility (EMC) directive 2004/108/EC.
- Relevant standards in Safety directive 2006/95/EC, supported by Certified Body (CB) Test Certificates issued by the National Certification Body as tested to IEC 60950 with national differences for participating countries .
- Underwriters Laboratories (UL) listed under UL File E200146 for USA and c-UL for Canada. [Figure 2-2](#) shows the mark used to indicate this compliance.

Figure 2-2 Combined UL Mark for the United States and Canada



- Relevant standards in SJ/T 11363-2006 for limits of certain hazardous substances.

Figure 2-3 Hazardous Substances

| 部件名称 (Parts) | 有毒有害物质或元素 (Hazardous Substance) | | | | | |
|---|---------------------------------|-----------|-----------|----------------------------|---------------|-----------------|
| | 铅 (Pb) | 汞 (Hg) | 镉 (Cd) | 六价铬 (Cr ⁶⁺) | 多溴联苯 (PBB) | 多溴二苯醚 (PBDE) |
| 金属部件 (Metal Parts) | ○ | ○ | ○ | ○ | ○ | ○ |
| 电路模块 (Circuit Modules) | × | ○ | ○ | ○ | ○ | ○ |
| 电缆及电缆组件 (Cables & Cable Assemblies) | × | ○ | ○ | ○ | ○ | ○ |
| 塑料和聚合物部件 (Plastic and Polymeric parts) | ○ | ○ | ○ | ○ | ○ | ○ |

○: 表示该有毒有害物质在该部件所有均质材料中的含量均在SJ/Txxxx-xxxx标准规定的限量要求以下。
Indicates that the concentration of the hazardous substance in all homogeneous materials in the parts is below the relevant threshold of the SJ/T 11363-2006 standard.

×: 表示该有毒有害物质至少在该部件的某一均质材料中的含量超出SJ/Txxxx-xxxx标准规定的限量要求。
Indicates that the concentration of the hazardous substance of at least one of all homogeneous materials in the parts is above the relevant threshold of the SJ/T 11363-2006 standard.

Pre-Installation Site Requirements

Before installing E5-APP-B cards into an EAGLE shelf, make sure that the requirements described in both of the following sections have been met.

- [Generic Site Requirements](#)
- [Grounding and Power Requirements](#)

Generic Site Requirements

Ensure that the site where the product will be installed conforms to the specifications listed in the following sections. These specifications are standard telephony industry requirements for equipment installation.

Fire Protection

Local fire protection codes must be satisfied in the equipment room where the system is to be located.

Environmental Requirements

Oracle Communications products are designed for environments that have temperature and humidity controls. Temperature and humidity controls must be activated as quickly as possible for equipment to operate at an optimum level.

When temperature and humidity controls fail, the equipment has been tested to operate within the following ranges:

- Temperature
 - 5° C to 40° C (41° F to 104° F) for normal operation
 - -5° C to 50° C (23° F to 122° F) for no more than 96 hours in duration and at elevations less than 1800 meters
 - -5° C to 50° C (23° F to 122° F) for storing the product
- Humidity
 - 5% to 85% non-condensing for normal operation
 - 5% to 90% non-condensing (but not to exceed 0.024 kilograms of water per kilogram of dry air) for no more than 96 hours in duration and at elevations less than 1800 meters

Oracle Communications products are tested to operate at an elevations within the following range:

- Minimum: 60 meters below sea level at ambient temperature of 30° C (86° F)
- Maximum: 4000 meters above sea level at ambient temperature of 40° C (104° F)

HVAC Requirements

Oracle Communications products are designed to bring cool air in from the bottom front and exit heated air out the top rear of the installed equipment.

The required **HVAC** (Heating, Ventilation, and Air Conditioning) capacity depends on the installed equipment. To calculate needed **HVAC** capacity, determine the total wattage of the installed equipment and use the following formula:

$$\text{BTUs/hr.} = \text{watts} \times 3.413$$

The amount of power required by frame components is found at: DC_PowerReqmts.pdf.

The E5-APP-B card must be installed in a fully populated EAGLE shelf with a fan tray and air management cards, if necessary.

Lighting

Adequate lighting should be provided in the room where the equipment is to be located. Lighting fixtures must be far enough from the equipment and cables to prevent heat damage and to allow safe access to equipment and cables.

Earthquake Resistance

All Oracle Communications system configurations are designed to assure that the system remains operational during and after an earthquake, even when the system is located on the upper floors of a zone 4 central office.

Space Requirements

Provide space as described in [Generic Site Requirements](#). These space requirements provide for Oracle Communications equipment installed in a 23-inch heavy-duty frame, which measures 7 feet high. Separator panels and end panels add to the width of multiple frame systems.

Table 2-1 Space Requirements

| Building Area | Dimensions | Notes |
|-----------------------|--|--|
| Halls | 4.5 feet wide by 8 feet tall (1.4 meters wide by 2.4 meters tall) | To provide a clear, uncluttered route for moving equipment between the loading/receiving dock and the planned system location |
| Frame location | 30 inches wide by 24 inches deep (76.2 cm wide by 60.96 cm deep) | Floor area recommended for one Oracle Communications frame (multiply by the number of frames listed on the Initial Sales Order) Total area per frame = 720 square inches (5.0 square feet) (0.465 square meters) |
| Side aisles | 4 feet (1.2 meters) | To allow maneuvering frames into place and provide ample work space around the equipment |
| Front and rear access | 3 feet 6 inches (107 cm) | From walls or other frames |
| Side access | 12 inches (31 cm) | From walls or other frames |

In addition, when planning the installation, be sure to take into account spare hardware storage, modems, terminals, printers, cross connect panels, and all other items that might require space in a system.

Floor Loading

Oracle Communications products installed in heavy-duty control or extension frames are designed for installation on raised or solid floors, which are recommended to have a distributed load capacity of no less than 100 pounds per square foot (504 kg/m²) and a maximum weight of EAGLE 5 ISS 850 lbs (386 kg).

Use the following equation to calculate the floor loading:

$$\text{Distributed floor capacity} = \text{Total equipment weight} / \text{floor area}$$

Grounding and Power Requirements

Before installing E5-APP-B cards into an EAGLE shelf, make sure that the grounding and power requirements in the appropriate following sections have been met.

- [Grounding Requirements](#)
- [EAGLE Shelf Power Requirements](#)

Grounding Requirements

Oracle Communications systems operate as digital isolated ground plane systems in a central office environment and require a single connection to the central office ground window. The system's ground cables must provide the sole grounding connection between the entire system and the central office grounding.

warning

Always install an isolator pad between the frame and ground. Oracle Communications frames are shipped with isolator pads to completely isolate the frames from ground. If a non-Oracle Communications frame is used, an isolator pad must be provided.

The system can use three types of grounding paths:

- **Battery return**
The battery return grounding path is the return path for all –48VDC loads in the system. This path is isolated from other system grounds and connects to the rest of the central office through the –48VDC return connections located on the breaker panels of each frame.
- **Logic Ground**
Some system types require connection to a logic ground. The logic ground path provides a common voltage reference point between all circuit boards of a system. Each connection terminates to the system ground. The logic ground path is shown on your system's interconnect drawing. The logic ground path does not carry current.
- **Frame/shelf ground**
The frame/chassis ground path provides a low impedance connection for all metal parts of the entire system, including the frame, doors, shelves, and end panels. Each frame/chassis connection within the system lineup terminates to the frame and connects to the main ground by way of Htaps, #6 American Wire Gauge (**AWG**) to 1/0 cable.

Note

The frame/chassis ground path does not carry current.

For products installed in a frame, the doors installed are grounded to the frame through a two-hole lug ground wire and through a screw-down latch. [Figure 2-4](#) shows a cutaway view example of an open frame door showing the door ground strap.

Figure 2-4 Door Grounding Strap Placement

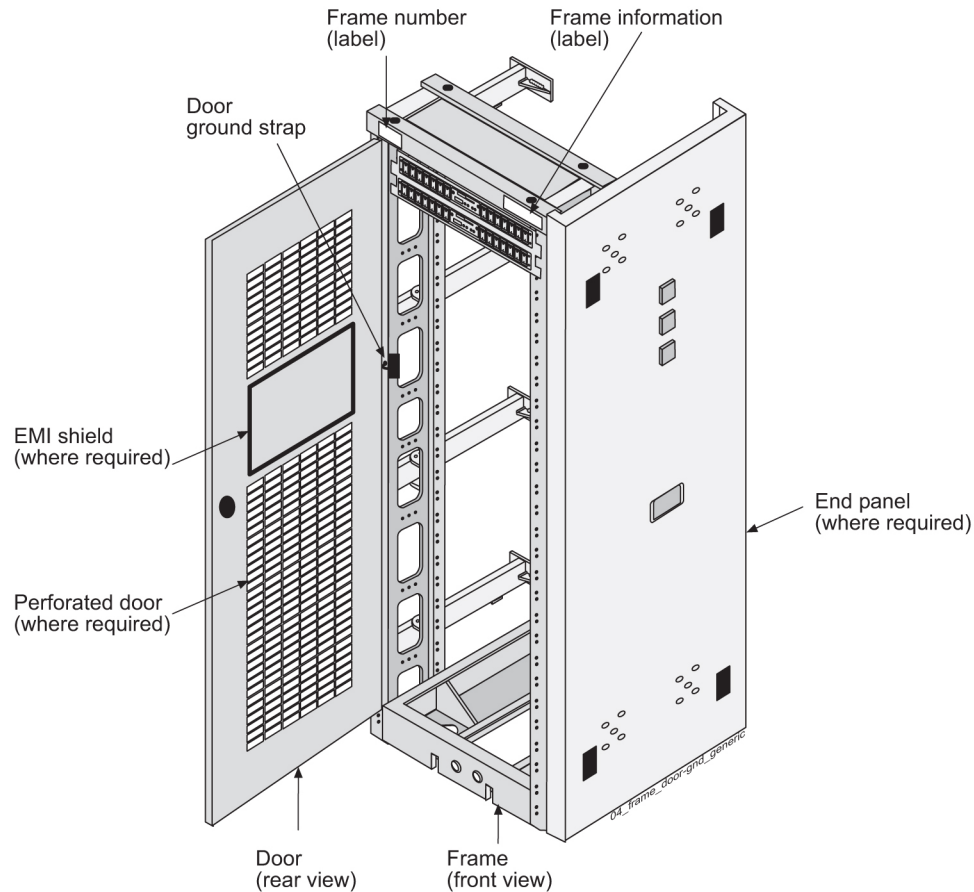

EAGLE Shelf Power Requirements

E5-APP-B cards use power resources of the frame in which the EAGLE shelf is installed. Each card is fused at 3A. There is detailed information in the Power Calculator spreadsheet available on the Oracle Communications Customer Support site.

Note

EAGLE cannot provision two E5-APP-B cards running the same application in slots with the same power sources in different frames unless the `force=yes` parameter is used.

3

E5-APP-B Card Overview

This chapter presents an overview of the E5-APP-B card package, components, and adapter interfaces.

Note

For the complete list of cards supported by EAGLE Release 47.1, see *Hardware Reference Guide*.

Introduction

E5-APP-B card packages are designed to be integrated with features that run on a **Signal Transfer Point (STP)**. **E5-APP-B** cards for these applications run in a Direct Current (**DC**) environment and are delivered as a pair to be installed in an EAGLE using heavy duty frames, along with breaker panels and Ethernet communication equipment.

Note

The E5-APP-B Card is not IMT Bus capable.

For more information about EAGLE shelves, see the *EAGLE Hardware Guide*.

This chapter provides an overview of E5-APP-B cards and highlights E5-APP-B card features, components, and adapter interfaces.

E5-APP-B Card

An E5-APP-B card comes with two removable drive modules when first ordered. A complete shipping package for applications includes:

- Two E5-APP-B standard EAGLE double-wide cards, identified as A and B. Each E5-APP-B card is loaded at the factory with platform software and application software.
- Two removable drive modules for each separate card. For more information about these components, refer to the documentation delivered with the product.

Note

The -01 card is smaller (300GB) than the -02 card, which has a 480G drive. The only difference between the two card types is SSD capacity.

[Figure 3-1](#) shows an example E5-APP-B card in a shelf(1).

The E5-APP-B card is a scalable computing platform constructed with state-of-the-art components packaged on a double-wide card designed to fit into two slots of an EAGLE shelf. Each E5-APP-B card has two removable drive modules. E5-APP-B cards are installed in pairs for redundancy and high availability.

[Figure 3-2](#) shows a single E5-APP-B card. This view shows where hardware components, especially Field Replaceable Units (**FRUs**), are located.

Figure 3-2 E5-APP-B Card

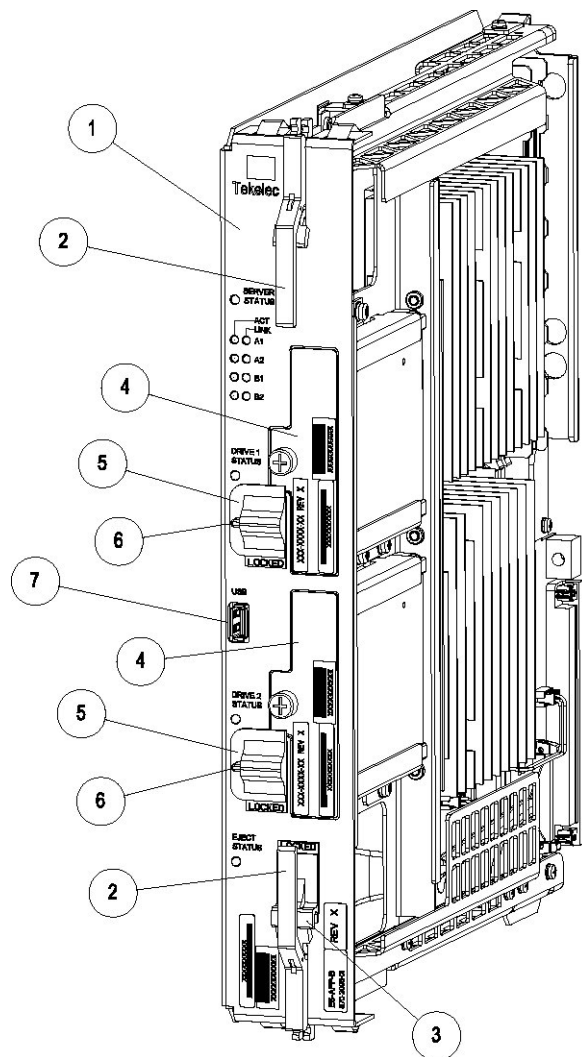

The following are Field Replaceable Units:

- E5-APP-B card (1)
- Drive Module (4)

For more information about **FRUs**, see the corresponding *Alarms and Maintenance* guide included in this release.

The other features components are:

- Injector/Ejector (2)

- Ejector Switch (3)
- Drive module locking switch (5)
- Switch lock release (6)
- USB Port (7) - Used for software upgrades

E5-APP-B Card Status Indicators

Figure 3-3 E5-APP-B Card Indicators

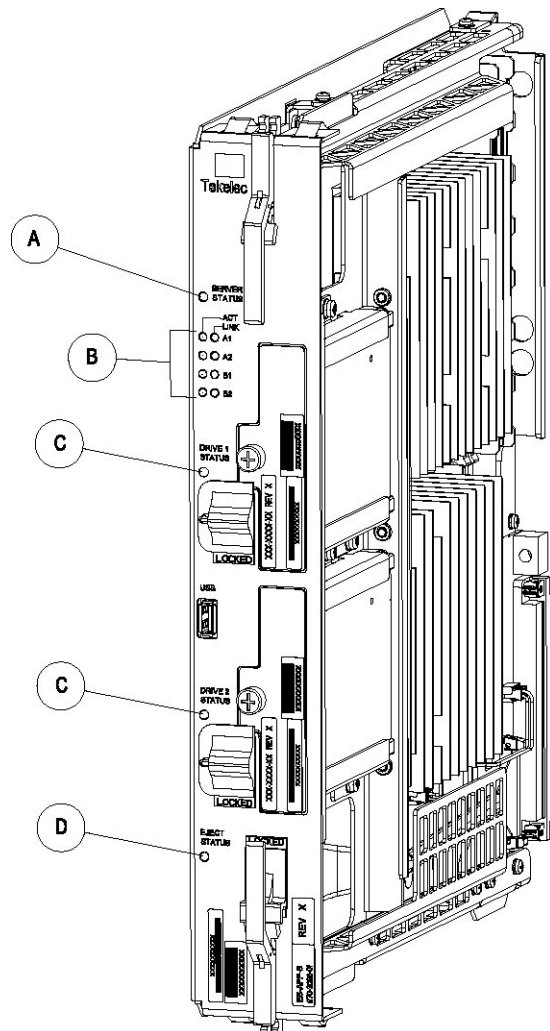

The following light-emitting diode (**LED**) status indicators (see [Figure 3-3](#)) can be found on the E5-APP-B card:

- One Server Status indicator (A)
- Four E-Net link and Active LED status indicators (B)
- Two drive module status indicators (C)
- One Card Eject status indicator (D)

For more information about the diagnostics that manage these alarm and status indicators, see [E5-APP-B Card Diagnostics](#).

E5-APP-B Card Installation

A single E5-APP-B card is installed in two adjacent EAGLE shelf slots. To install two E5-APP-B cards for redundancy (the recommended configuration), the EAGLE must have room to install two double-width cards.

E5-APP-B Card Components

The E5-APP-B card consists of the following standard hardware components:

- Dual Core 2.66GHz 64-bit processor
- Active/Trial BIOS architecture
- 1333 megahertz (MHz) processor front side bus speed
- 8 GB DDR2 DRAM
- Light Emitting Diode (LED) status display
- Hardware monitors that read and report:
 - Supply and core voltages
 - Fan alarm inputs
 - Ambient and processor temperatures
- Two drive modules (Field-replaceable Units (FRUs))

E5-APP-B Card Interfaces

The E5-APP-B card includes interfaces for accommodating expansion, control and configuration, network connectivity, and peripheral support.

[Table 3-2](#) shows the basic interfaces on the E5-APP-B card.

Table 3-2 E5-APP-B Card Interfaces

| Interface | Description |
|--------------------------------------|---|
| Four Serial interfaces | Standard RS-232D serial interfaces are usually used for connecting to other equipment. The Serial interfaces are accessed via backplane adapters. |
| One USB port - For software upgrades | One Universal Serial Bus (USB) port to support direct connectivity to peripherals. The USB port is accessible from the E5-APP-B card front panel. |
| Fan Alarm | Fan Alarms are received through the application GUI. See E5-APP-B Fan Alarms for more information. |
| Four 1 Gigabit (Gb) Ethernet ports | Ethernet ports to communicate with other nodes on the network. The Ethernet ports are accessed via backplane adapters. |

Electrical Features

The E5-APP-B card has the following standard electrical features:

- Operates from -40 **VDC** to -56.7 **VDC** power input, according to Network Equipment Building System (**NEBS**) requirements in accordance with typical telecommunications applications
- Includes short-circuit protections and safety precautions in accordance with common standards

Mechanical Design and Maintenance Features

The E5-APP-B card mechanical design meets all applicable **NEBS** requirements and is designed to protect all active components. The design has efficient component cooling using low-impedance air paths, and its compact size allows multiple units to be configured in a shelf with zero clearance.

The E5-APP-B card has been designed for easy maintenance. The following components are Field-replaceable Units (**FRUs**):

- The E5-APP-B card
- The drive module assembly

The E5-APP-B card includes solid state disk drives (SSD) equipped with means to detect the end of the drive's service life. The drives have been selected to exceed the overall service life of the cards themselves, but in the event that a drive begins to approach the end of its service life, the E5-APP-B card will display the following warning:

```
Device: /dev/sdX [SAT], SMART Failure: FAILURE PREDICTION THRESHOLD  
EXCEEDED: ascq=0xNN
```

To avoid an unexpected disruption in service, the operator must identify the drive designated as device "`/dev/sdX`" and replace it as soon as possible.

The disk drives have high mean time between failures (**MTBF**) and can be easily replaced.

Note

When removing or replacing **FRUs**, use the procedures in the corresponding *Alarms and Maintenance Guide* for this release, if available. Use the inject/eject switch on the E5-APP-B card before switching **OFF** all circuit breakers or power distribution units supplying redundant power. For more information about troubleshooting systems and performing soft shutdowns, see the appropriate maintenance guide for the application.

E5-APP-B Card Diagnostics

All components that comprise the E5-APP-B card platform are designed for testability to ensure that operational status can be accurately determined and that appropriate levels of fault detection and isolation are possible with a minimum of effort.

The following levels of diagnostics are provided:

1. Online diagnostics actively monitor the health of a running E5-APP-B card platform. When online diagnostics encounter a problem, an alarm is raised and front fascia light-emitting diodes (**LEDs**) are illuminated to indicate the status of certain components of the E5-APP-B card. For more information about the E5-APP-B card LEDs, see [Table 3-3](#). Online diagnostics can be run while maintaining in-service operation of node.

Diagnostics enable troubleshooting of installed systems by verifying operational capability of Field Replaceable Units (**FRU**) and operational status of peripheral system components (such as cables and connectors) through automated testing initiated by **FRU** components. Examples are loop-back and link tests.

Table 3-3 E5-APP-B LED Table

| LED Name | HW/SW Controlled | Description |
|----------------|------------------|--|
| Server Status | SW | Solid Red - Server is halted Flashing Red - Server is booting Solid Amber - TKLC configuration beginning Solid Green - TPD loaded/operational state Flashing Green - Server is shutting down |
| Drive 1 Status | SW/HW | HW: Flashing Green - Drive activity SW: Flashing Red - Impending drive removal SW: Steady Red - Drive ready for removal |
| Drive 2 Status | SW/HW | HW: Flashing Green - Drive activity SW: Flashing Red - Impending drive removal SW: Steady red - Drive ready for removal |
| Eject Status | SW | Red - Card ready for extraction Flashing Red - Card preparing for extraction Off - Card is not ready for extraction |
| Act LED A1 | HW | Flashing Green - Link Activity |
| Act LED A2 | HW | Flashing Green - Link Activity |
| Act LED B1 | HW | Flashing Green - Link Activity |
| Act LED B2 | HW | Flashing Green - Link Activity |
| Link LED A1 | HW | Green - 10/100 Link Speed Amber - 1000 Link Speed |
| Link LED A2 | HW | Green - 10/100 Link Speed Amber - 1000 Link Speed |
| Link LED B1 | HW | Green - 10/100 Link Speed Amber - 1000 Link Speed |
| Link LED B2 | HW | Green - 10/100 Link Speed Amber - 1000 Link Speed |

4

Installing and Removing E5-APP-B Cards

This chapter covers provisioning rules and installation and removal procedures for E5-APP-B cards.

Introduction

This chapter describes how to install and remove an E5-APP-B card from an EAGLE shelf, as well as shut down procedures for specific applications.

Note

E5-APP-B cards are installed in an EAGLE in pairs to operate redundantly and provide high availability service.

Although installed in an EAGLE slot in an EAGLE shelf, an E5-APP-B card does not use the IMT bus. However, the E5-APP-B card does use power provided by the EAGLE frame. Because the E5-APP-B card is not detected on the IMT bus, it is not calculated into the power consumption needs of the unit; Therefore, certain power requirements apply to the E5-APP-B card. Refer to the [Obtaining the EAGLE Power Calculator](#) to manually determine EAGLE frame power consumption needs with the E5-APP-B card installed. With EAGLE Release 45.0, E5-APP-B will be part of the frame Power Calculation automatically if it is entered into the EAGLE System.

Provisioning Rules for E5-APP-B Cards

When installing an E5-APP-B card in an EAGLE shelf, take the following provisioning rules under consideration:

Note

In order to facilitate the ability to use a common spare E5-APP-B card for all applications, spare E5-APP-B cards are delivered with only the 64-bit version of the Oracle Communications Tekelec Platform (TPD) operating system pre-installed. When replacing an existing LSMS E5-APP-B card with a spare E5-APP-B card, ensure that the card has the 32-bit version of TPD installed. Refer to the *TPD Initial Product Manufacture User's Guide* for assistance. For all applications (including LSMS), after verifying that the TPD version is correct, refer to the application-specific Installation/ Upgrade Procedure to install the application.

- E5-APP-B cards must be installed on separate power feeds within the shelf for redundancy purposes.
- E5-APP-B cards must be installed in odd number slot locations (i.e., xx01, xx03, xx05, etc.).
- Fan trays (890-0001-xx) are required for all EAGLE shelves that host an E5-APP-B card.

- Air management cards must be placed in open full-height slots within the shelf to provide proper air flow to the E5-APP-B cards.
- E5-APP-B based Oracle Communications **EAGLE** LNP Application Processor (**ELAP**) or **EAGLE** Application Processor Provisioning (**EPAP**) systems do not support DSM cards (870-1984-xx). DSM cards must be replaced with Oracle Communications EAGLE Service Module (E5-SMxG) cards.

E5-APP-B Fan Alarms

E5-APP-B cards that are being deployed in a remote EAGLE shelf or in EAGLE shelf 6200 or 6300 will have adapters and fan alarm cables installed so the application will receive Fan Alarms through the application Graphical User Interface (GUI).

E5-APP-B cards that are deployed in EAGLE shelf 1200 through 6100 will not have fan alarm cables and adapters. Fan alarms are displayed on the EAGLE terminal.

IMT Bus

The following IMT bus considerations apply when installing and provisioning an E5-APP-B card in an EAGLE shelf.

- E5-APP-B cards for EPAP, ELAP, or LSMS will not be on the IMT bus regardless of placement in an existing EAGLE shelf. However, they can be deployed in EAGLE shelves connected to the IMT bus if the frame is in the EAGLE line-up.
- The E5-APP-B card must be provisioned and its power consumption specified when the card is installed in any slot in the 1100 through 6300 shelves so that its power consumption may be included with the EAGLE Power Calculations.
- Other EAGLE cards can be used in shelves connected to the IMT bus.
- EAGLE shelf positions 6200 and 6300 do not connect to the IMT bus (existing EAGLE shelf limit on IMT bus remains 16).

E5-APP-B Power Guidelines

When installing an E5-APP-B card in an EAGLE shelf, the following power guidelines apply:

- Dual 60 A power feeds *are recommended* for all frames that host B series cards. EAGLE frames that host B series cards *may require* dual 60 Amp power feeds, depending on frame configuration.
- Frames equipped with 30 A power feeds/FAP can support one shelf with a fan assembly but an upgrade to 60A power feeds/FAP is recommended.
- Frames equipped with 40 A power feeds/FAP can support two shelves with fan assemblies, but an upgrade to 60A power feeds/FAP is recommended.
- For non-standard frame configurations, use the Power Calculator Tool (SS005963) to determine if adequate power feeds exist at the customer site. For more information on Obtaining the EAGLE Power Calculator, see the following section.

Obtaining the EAGLE Power Calculator

To retrieve the Eagle Power Calculator:

1. Log into the <https://support.oracle.com> (MOS) site.

Note

If you have not registered for this new site, click the **Register Here** link. Have your customer number available. The response time for registration requests is 24 to 48 hours.

2. Click the **Product Support** tab.
3. Enter SS005963 into the search field.
4. Save the file to a local directory.

E5-APP-B Card Distance Limitations

When installing an E5-APP-B card in an EAGLE shelf, take the following distance limitations under consideration:

- 328 Feet (100 Meters) maximum cable length between Switches and EAGLE Service Modules.
- 100 Feet (30.5 Meters) maximum cable length between E5-APP-B cards and Switches for serial connectivity
- 100 Feet (30.5 Meters) maximum cable length between E5-APP-B cards and EAGLE Control Shelf for serial MMI connectivity to the B server card (Optional: ELAP and EPAP only)
- 328 feet (100 Meters) maximum cable length between Switches and E5-APP-B

Installing an E5-APP-B Card

To install an E5-APP-B card into an EAGLE shelf:

Note

The E5-APP-B Card should arrive in the LOCKED state. If it arrives UNLOCKED, skip to step 4.

1. On the E5-APP-B card, slide the Ejector switch (4) up to the UNLOCKED position. See [Figure 4-1](#).

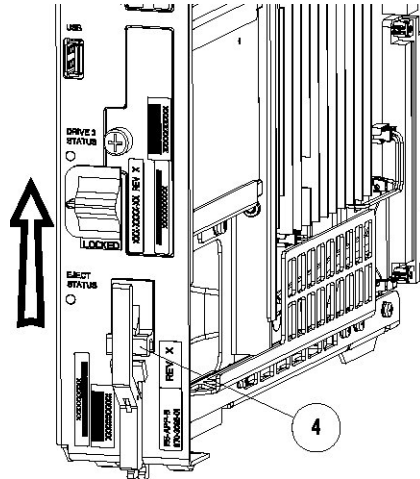
Figure 4-1 E5-APP-B Card Inject Hardware Switch, UNLOCKED

2. Grasp the upper and lower card Inject/Eject (I/E) lever release (3) just underneath the I/E lever, and press it to meet the I/E lever. This is the mechanical interlock for the card (see [Figure 4-3](#)).
3. While holding the I/E interlock and lever, pull the levers (2) away from the card until they are parallel to the floor.

[Figure 4-2](#) illustrates the angle of the interlocks and levers just before inserting E5-APP-B Card into the EAGLE shelf.

Figure 4-2 E5-APP-B Card UNLOCKED

4. Insert the E5-APP-B card into the EAGLE shelf.
Carefully align the edges of the card with the top and bottom card guides. Then, push the card along the length of the card guides until the rear connectors on the card engage the mating connectors on the target shelf backplane.
5. Push in the top and bottom inject/eject clamps (see [Figure 4-3](#)).

Figure 4-3 E5-APP-B Card Inject Levers

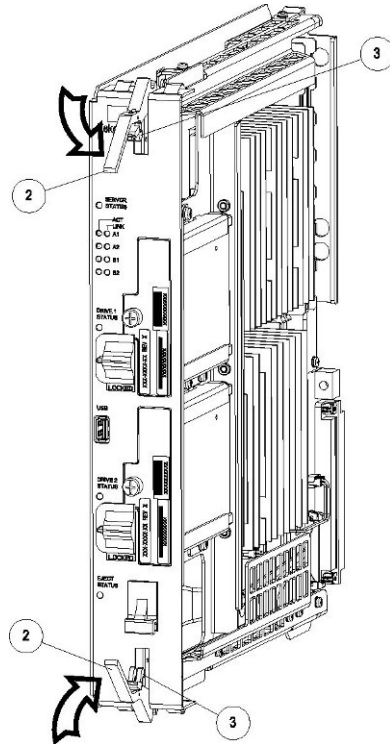

This locks the card in place and ensures a strong connection with the pins on the target shelf backplane.

6. Slide the E5-APP-B H/S switch (4) down to the LOCKED position (see [Figure 4-4](#)).

Note

When the Ejector switch goes from UNLOCKED to LOCKED, the E5-APP-B Eject Status LED blinks red as the E5-MASP card goes online.

Figure 4-4 E5-APP-B Card Inject Hardware Switch, LOCKED

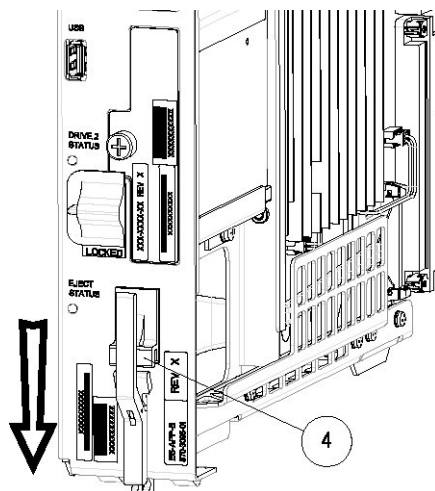

7. WAIT for the E5-APP-B Eject Status LED to go from blinking red to off.

Removing an E5-APP-B Card

Procedure - Remove E5-APP-B card

Note

The shutdown, `init 6` or `halt` commands will not shut down the E5-APP-B card.

1. On the E5-APP-B card, slide the Ejector switch (4) up to the UNLOCKED position (see [Figure 4-5](#)).

Caution

When the Ejector switch goes from locked to unlocked and the E5-APP-B card is in service, the card will halt.

Figure 4-5 E5-APP-B Card Eject Hardware Switch, UNLOCKED

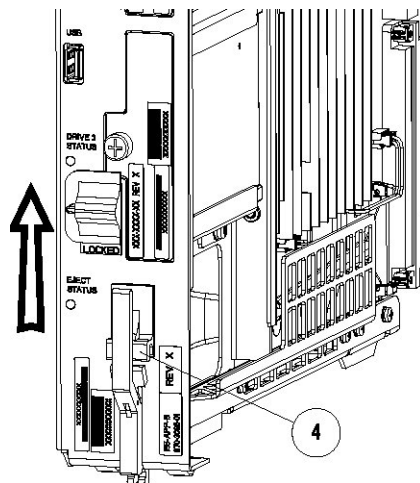

2. WAIT for the E5-APP-B Eject Status LED to go from blinking red to a steady red.
When the Eject Status LED is steady red, the E5-APP-B card is in shutdown state.
If the Ejector switch is put into the LOCKED position now, the E5-APP-B card will reboot.
3. Grasp the upper and lower card Inject/Eject (I/E) lever release (3) just underneath the I/E lever, and press it to meet the I/E lever. This is the mechanical interlock for the card.

See [Figure 4-6](#)

Figure 4-6 E5-APP-B Card UNLOCKED

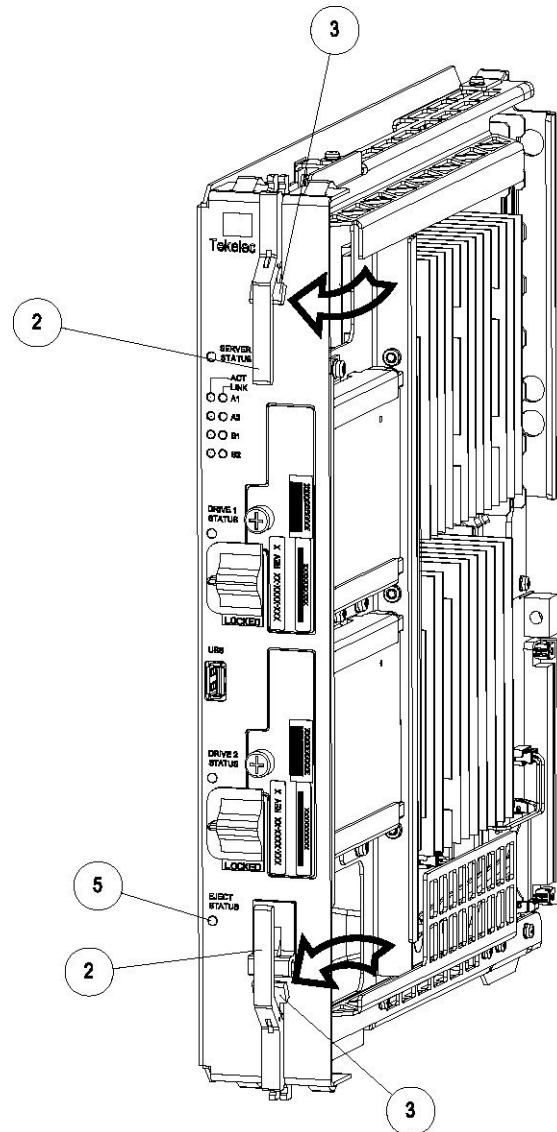

4. While holding the I/E interlock and lever, pull the levers (2) away from the shelf until they are parallel to the floor.
5. Remove the E5-APP-B card from the EAGLE shelf.

E5-APP-B Card Adapter Interfaces

The E5-APP-B card supports an upper and a lower backplane adapter, which supports the following interfaces:

- 1 Gigabit (Gb) Ethernet (830-1102-03)
- Serial (830-1407-01)
- Fan alarm

Changing Passwords

For security purposes, Oracle recommends that all default passwords be changed and kept in a secure location.

- To change the passwords for E5-APP-B platforms, refer to the application guide for the application loaded on each server.

Note

There should always be a person on-site who knows the new passwords. If there is a need to contact the [My Oracle Support \(MOS\)](#), provide the passwords on request.

A

ExAP or LSMS Network Integration

This chapter provides network integration information for Multi-Purpose Server (MPS) systems and Oracle Communications LSMS (Local Service Management Systems).

Introduction

The MPS platform can be configured as an Oracle Communications **EAGLE** LNP Application Processor (**ELAP**) or **EAGLE** Application Processor (**EPAP**) server. The **MPS** platform is an **ELAP/EPAP** system based on the **E5-APP-B** card platform.

The MPS provides an interface between the customer provisioning network and the **EAGLE** Service Module (**SM**) cards. As the customer's data is updated, the MPS stores the data and updates the **SM** cards. An MPS is usually co-located with an **EAGLE**. If you need to install an MPS at a distance from the **EAGLE**, contact your [My Oracle Support \(MOS\)](#) for assistance.

The LSMS uses a NAS to backup system and application logs, as well as databases. The **E5-APP-B** NAS has a two-drive storage in RAID configuration to save the LSMS logs and database. The NAS is initially configured through the primary LSMS using tty serial terminal.

Network Overview

ExAP Network Connections

[Figure A-1](#), [Figure A-4](#) and their corresponding tables [Table A-1](#) and [Table A-2](#), respectively, illustrate the networks and how they are connected.

All networks, except the provisioning network, use internal connections in the MPS. Only the provisioning network connects to the customer's network. All networks use **TCP/IP** and **UDP/IP** as the transport protocol.

- The provisioning network uses the Ethernet interface that typically connects to an external wide area network (**WAN**). This interface provides connectivity to the remote **MPS** system, an **LSMS**, or to a customer-provided provisioning system.
- The main **SM** Network uses the Ethernet interface that connects to the primary network port on all **SM** cards. This network has sufficient capacity to support up to 32 (for EPAP, 18 for ELAP) **SMs**. The primary port on all **SM** cards runs at 1G.

Figure A-1 EPAP Network Connections

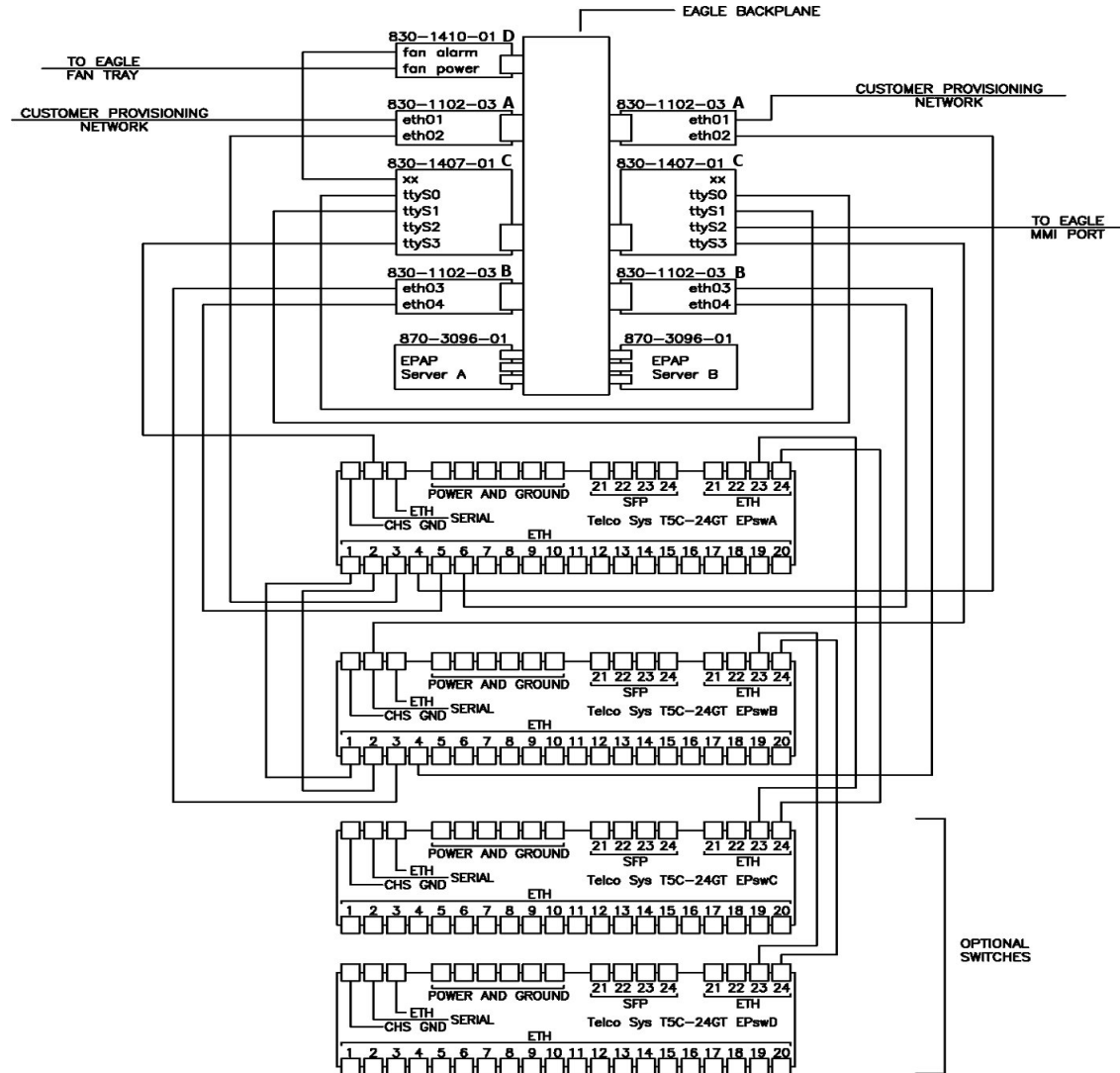

- A. Adapter installed in the Upper position, odd slot
- B. Adapter installed in the Lower position, odd slot
- C. Adapter installed in the Lower and Upper position, even slot
- D. Adapter installed on EAGLE backplane fan Connector (Power and Alarm)

Table A-1 EPAP Interconnect Table

| Cable Part Number | To | From |
|------------------------------|-----------------------------------|----------------------------------|
| 830-1173-68 CAT 5 Crossover | Switch A port 1 | Switch B port 1 |
| 830-1173-68 CAT 5 Crossover | Switch A port 2 | Switch B port 2 |
| 830-1220-XX Serial Roll Over | Card / Server A, (P3) 830-1407-XX | Card /Server B, (P4) 830-1407-XX |
| 830-1220-XX Serial Roll Over | Card /Server A, (P4) 830-1407-XX | Card /Server B, (P3) 830-1407-XX |
| 830-1220-XX Serial Roll Over | Card /Server A, (P6) 830-1407-XX | Switch A Console Port |
| 830-1220-XX Serial Roll Over | Card /Server B, (P6) 830-1407-XX | Switch B Console Port |

Table A-1 (Cont.) EPAP Interconnect Table

| Cable Part Number | To | From |
|----------------------------|--|---|
| 830-1174-XX CAT 5 Straight | Card /Server A Port A (P2) 830-1102-03 | Customer Provisioning Network ETH01 |
| 830-1174-XX CAT 5 Straight | Card /Server B Port A (P2) 830-1102-03 | Customer Provisioning Network ETH01 |
| 830-1174-XX CAT 5 Straight | Card /Server A Port A (P3) 830-1102-03 | Switch A Port 3 ETH02 |
| 830-1174-XX CAT 5 Straight | Card /Server B Port A (P3) 830-1102-03 | Switch A Port 4 ETH02 |
| 830-1174-XX CAT 5 Straight | Card /Server A Port B (P2) 830-1102-03 | Switch B Port 3 ETH03 |
| 830-1174-XX CAT 5 Straight | Card /Server B Port B (P2) 830-1102-03 | Switch B Port 4 ETH03 |
| 830-1174-XX CAT 5 Straight | Card /Server A Port B (P3) 830-1102-03 | Switch A Port 5 ETH04 |
| 830-1174-XX CAT 5 Straight | Card /Server B Port B (P3) 830-1102-03 | Switch A Port 6 ETH04 |
| 830-1173-68 Optional | Switch A port 23 (CAT 5) Crossover | Switch C port 23 |
| 830-1173-68 Optional | Switch A port 24 (CAT 5) Crossover | Switch C port 24 |
| 830-1173-68 Optional | Switch B port 23 (CAT 5) Crossover | Switch D port 23 |
| 830-1173-68 Optional | Switch B port 24 (CAT 5) Crossover | Switch D port 24 |
| 830-1413-XX | Card Server A (P2) 830-1407-XX | EAGLE Backplane Fan Connector (J2 B) 830-1410-XX |
| 830-1413-XX | Card Server B (P2) 830-1407-XX | EAGLE Backplane Fan Connector (J3 A) 830-1410-XX |
| 830-1212-XX | Card Server B (P5) | EAGLE MMI Port Optional Cable, requires adapter 830-1423-XX |

The Synchronization Network uses the Ethernet interface that is on private LAN segment. This interface provides direct connectivity between MPS A and MPS B.

Figure A-2 Sync Network Redundancy (Eth04 used for Sync Network) Interconnectivity

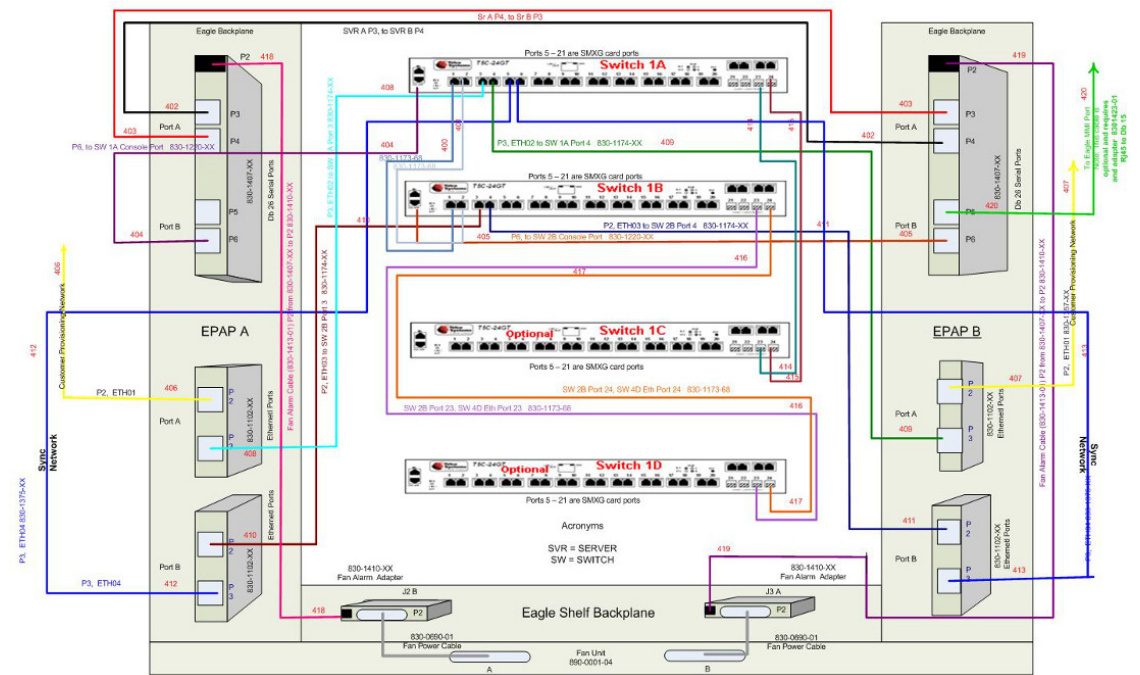

The backup **SM** Network uses the Ethernet interface that connects to the backup network port on all **SM** cards. This network has sufficient capacity to support up to 32 (for EPAP, 18 for ELAP) **SM**s. The backup port on all **SM** cards runs at 1G.

Figure A-3 Default (Eth04 Used for Backup Provisioning Network) Interconnectivity

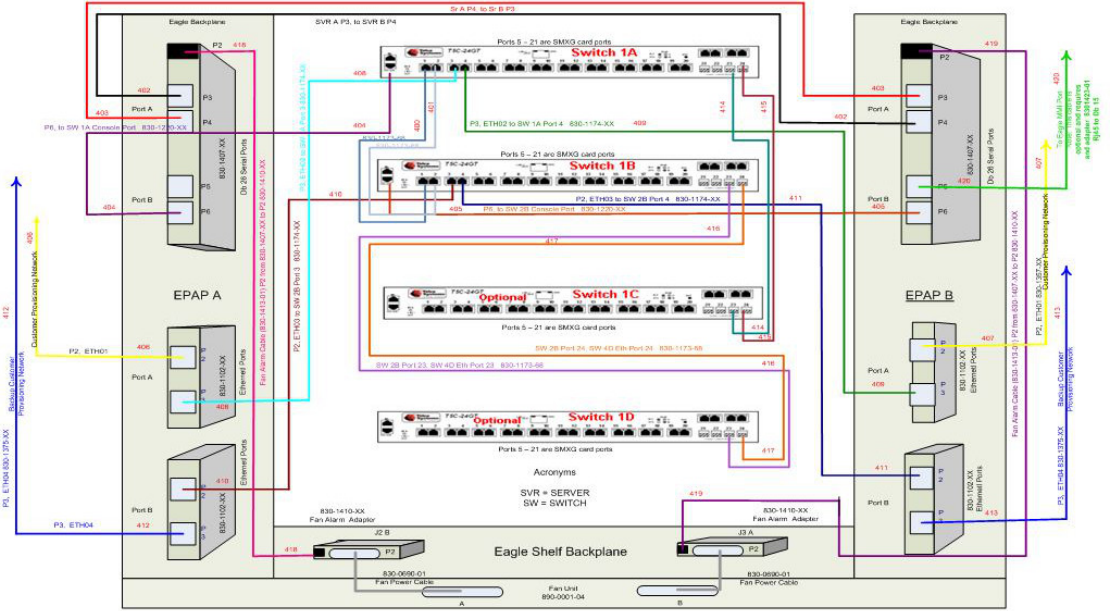

Figure A-4 ELAP Network Connections

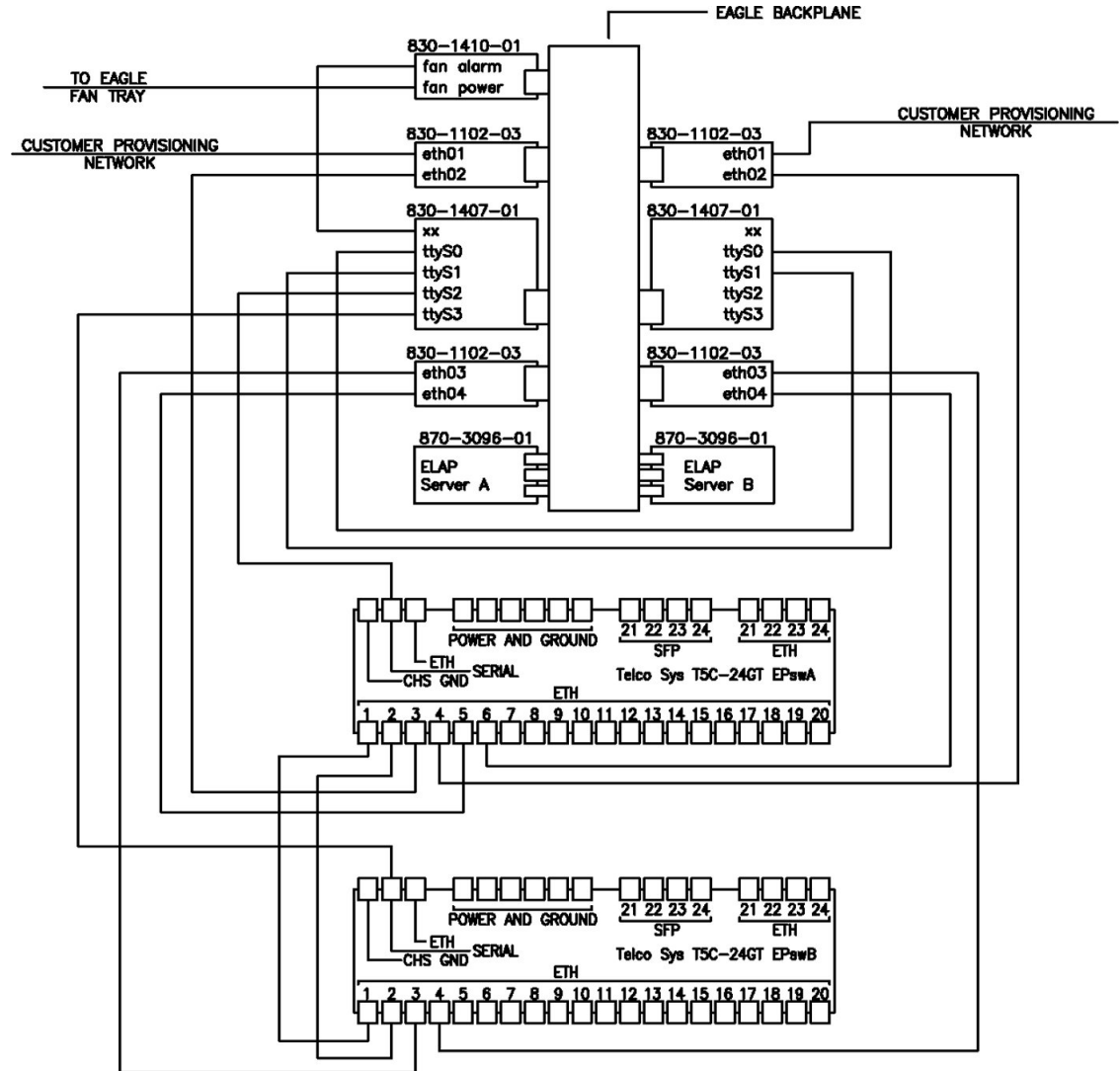

Table A-2 ELAP Interconnect Table

| Cable Part Number | To | From |
|------------------------------|---|--|
| 830-1173-68 CAT 5 Crossover | Switch A port 1 | Switch B port 1 |
| 830-1173-68 CAT 5 Crossover | Switch A port 2 | Switch B port 2 |
| 830-1220-XX Serial Roll Over | Card / Server A, (P3) 830-1407-XX TTYs0 | Card /Server B, (P4) 830-1407-XX TTYs1 |
| 830-1220-XX Serial Roll Over | Card /Server A, (P4) 830-1407-XX TTYs1 | Card /Server B, (P3) 830-1407-XX TTYs0 |
| 830-1220-XX Serial Roll Over | Card /Server A, (P5) 830-1407-XX TTYs2 | Switch A Console Port |
| 830-1220-XX Serial Roll Over | Card /Server A, (P6) 830-1407-XX Server A TTYs3 | Switch B Console Port |
| 830-1174-XX CAT 5 Straight | Card /Server A Port A (P2) 830-1102-03 ETH01 | Customer Provisioning Network ETH01 |

Table A-2 (Cont.) ELAP Interconnect Table

| Cable Part Number | To | From |
|----------------------------|---|---|
| 830-1174-XX CAT 5 Straight | Card /Server B Port A (P3) 830-1102-03 ETH02 | Switch A Port 3 ETH02 |
| 830-1174-XX CAT 5 Straight | Card /Server A Port A (P3) 830-1102-03 ETH02 | Switch A Port 4 ETH02 |
| 830-1174-XX CAT 5 Straight | Card /Server B Port A (P2) 830-1102-03 ETH03 | Switch B Port 3 ETH03 |
| 830-1174-XX CAT 5 Straight | Card /Server A Port B (P3) 830-1102-03 ETH04 | Switch A Port 5 ETH04 |
| 830-1174-XX CAT 5 Straight | Card /Server B Port B (P2) 830-1102-03 ETH01 | Customer Provisioning Network ETH01 |
| 830-1174-XX CAT 5 Straight | Card /Server A Port B (P2) 830-1102-03 ETH03 | Switch B Port 4 ETH03 |
| 830-1174-XX CAT 5 Straight | Card /Server B Port B (P3) 830-1102-03 ETH04 | Switch A Port 6 ETH04 |
| 830-1413-XX | Card Server A (P2) 830-1407-XX | EAGLE Backplane Fan Connector (J2 B) 830-1410-XX |

LSMS Network Connections

The Local Service Management System (LSMS) uses a NAS to backup system and application logs, as well as databases. The customer has the option of a Single Subnet configuration or Segmented configuration. The following figures and tables illustrate the different networks and how they are connected.

The LSMS Installation Kit includes a System Serial Number Label that should be applied to the frame's consolidated label. Refer to the "Label Application Instructions" that are included in *LSMS Installation Kit* for details.

Figure A-5 LSMS and NAS Single Subnet Connections

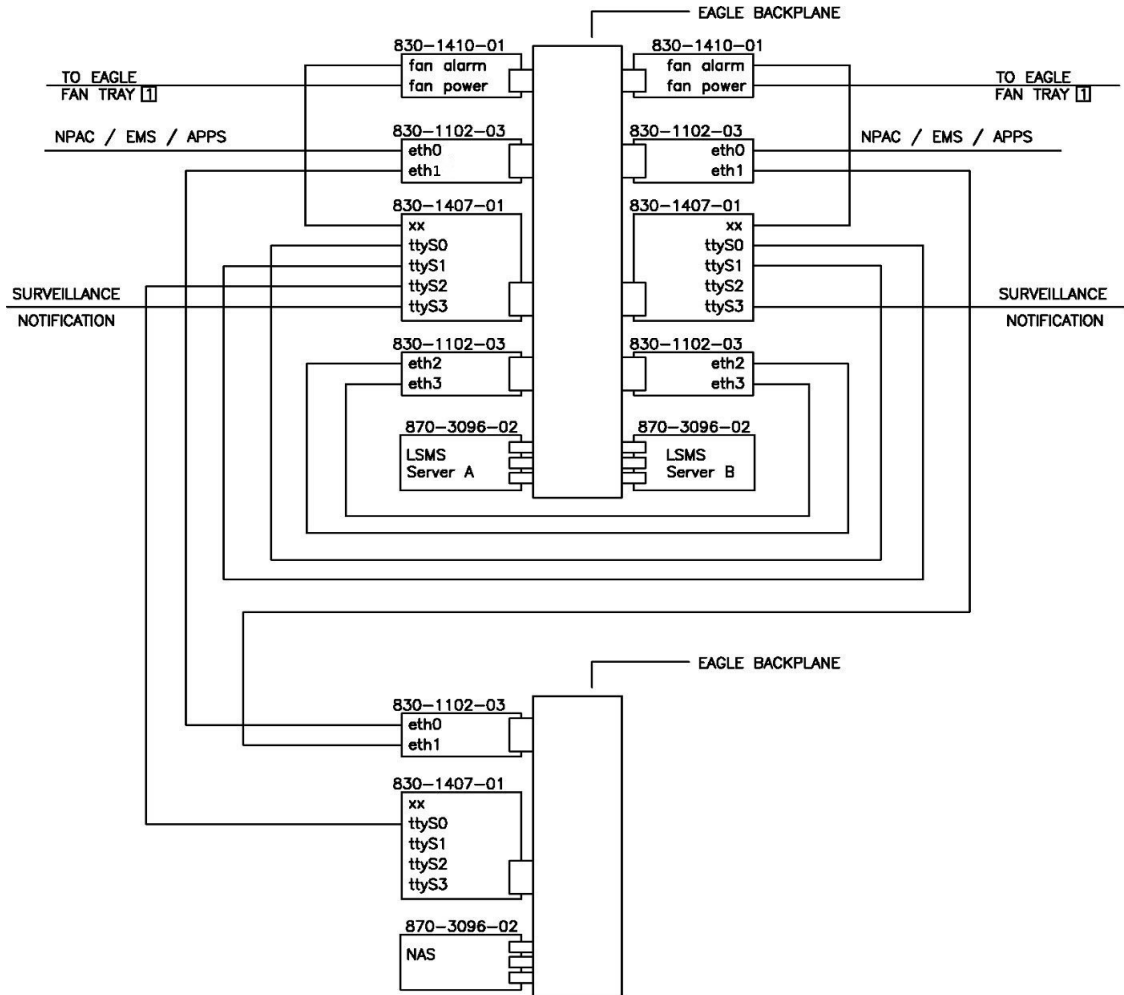

[1] WHEN INSTALLED IN A STAND-ALONE SHELF, THE FAN ALARMS ARE CONNECTED TO THE FIRST E5-APP-B SERVER IN THE SHELF

Table A-3 LSMS Single Subnet Interconnect Table

| Cable Part Number | To | From |
|------------------------------|---|---|
| 830-1174-XX CAT 5 Straight | Card /Server A Port A (P2)/ETH0 830-1102-03 | Customer Provisioning Network |
| 830-1174-XX CAT 5 Straight | Card /Server B Port A (P2)/ETH0 830-1102-03 | Customer Provisioning Network |
| 830-1174-XX CAT 5 Straight | Card /Server A Port A (P3) / ETH1 830-1102-03 | Card /NAS Port A (P2) / ETH0 830-1102-03 |
| 830-1174-XX CAT 5 Straight | Card /Server B Port A (P3) / ETH1 830-1102-03 | Card /NAS Port A (P3) / ETH1 830-1102-03 |
| 830-1174-XX CAT 5 Straight | Card /Server A Port B (P2) / ETH2 830-1102-03 | Card /Server B Port B (P2) / ETH2 830-1102-03 |
| 830-1174-XX CAT 5 Straight | Card /Server A Port B (P3) / ETH3 830-1102-03 | Card /Server B Port B (P3) / ETH3 830-1102-03 |
| 830-1220-XX Serial Roll Over | Card Server A (P3) 830-1407-XX | Card /Server B, (P4) 830-1407-XX |

Table A-3 (Cont.) LSMS Single Subnet Interconnect Table

| Cable Part Number | To | From |
|------------------------------|--------------------------------|---|
| 830-1220-XX Serial Roll Over | Card Server A (P4) 830-1407-XX | Card /Server B, (P3) 830-1407-XX |
| 830-1220-XX Serial Roll Over | Card Server A (P5) 830-1407-XX | Card /NAS, (P3) 830-1407-XX |
| 830-1220-XX Serial Roll Over | Card Server A (P6) 830-1407-XX | Surveillance Notification |
| 830-1220-XX Serial Roll Over | Card Server B (P6) 830-1407-XX | Surveillance Notification |
| 830-1413-XX | Card Server A (P2) 830-1407-XX | EAGLE Backplane Fan Connector (J2 B) 830-1410-XX (P6) |
| 830-1413-XX | Card Server B (P2) 830-1407-XX | EAGLE Backplane Fan Connector (J3 B) 830-1410-XX (P6) |

Figure A-6 LSMS and NAS Segmented Connections

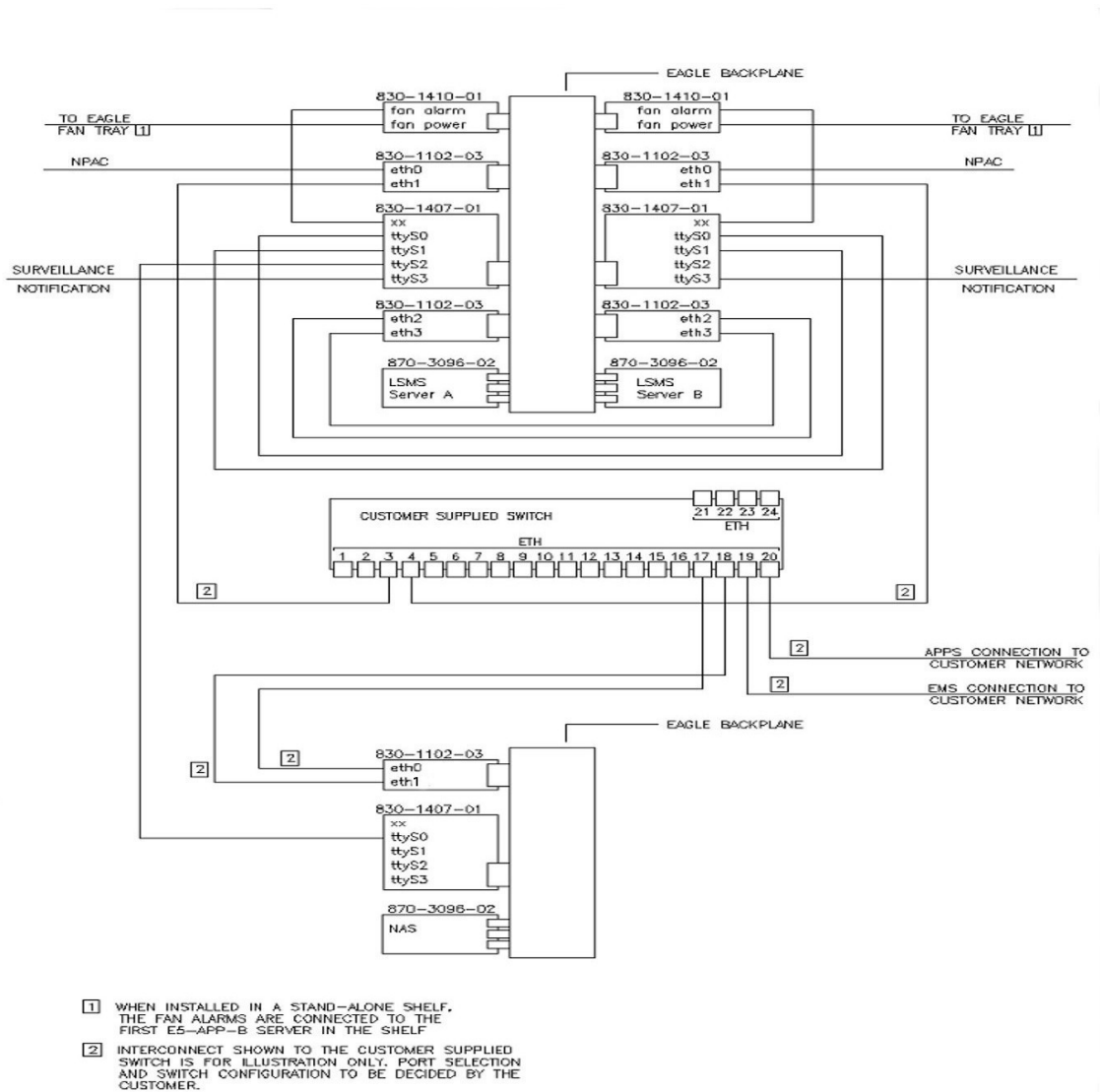

Table A-4 LSMS Segmented Interconnect Table

| Cable Part Number | To | From |
|------------------------------|--|--|
| 830-1174-XX CAT 5 Straight | Card /Server A Port A (P2) 830-1102-03 | NPAC |
| 830-1174-XX CAT 5 Straight | Card /Server B Port A (P2) 830-1102-03 | NPAC |
| 830-1174-XX CAT 5 Straight | Card /Server A Port A (P3) / ETH1 830-1102-03 | Customer Supplied Switch |
| 830-1174-XX CAT 5 Straight | Card /Server B Port A (P3) / ETH1 830-1102-03 | Customer Supplied Switch |
| 830-1174-XX CAT 5 Straight | Customer Supplied Switch | Card /NAS Port A (P2) / ETH0 830-1102-03 |
| 830-1174-XX CAT 5 Straight | Customer Supplied Switch | Card /NAS Port A (P3) / ETH3 830-1102-03 |
| 830-1174-XX CAT 5 Straight | Customer Supplied Switch | APPS |
| 830-1174-XX CAT 5 Straight | Customer Supplied Switch | EMS |
| 830-1174-XX CAT 5 Straight | Card /Server A Port B (P2) / ETH2 830-1102-03 | Card /Server B Port B (P2) 830-1102-03 |
| 830-1174-XX CAT 5 Straight | Card /Server A Port B (P3) / ETH3 830-1102-03 | Card /Server B Port B (P3) / ETH3 830-1102-03 |
| 830-1220-XX Serial Roll Over | Card Server A (P3) 830-1407-XX | Card /Server B, (P4) 830-1407-XX |
| 830-1220-XX Serial Roll Over | Card Server A (P4) 830-1407-XX | Card /Server B, (P3) 830-1407-XX |
| 830-1220-XX Serial Roll Over | Card Server A (P5) 830-1407-XX | Card /NAS, (P3) 830-1407-XX |
| 830-1220-XX Serial Roll Over | Card Server A (P6) 830-1407-XX | Surveillance Notification |
| 830-1220-XX Serial Roll Over | Card Server B (P6) 830-1407-XX | Surveillance Notification |
| 830-1413-XX | Card Server A (P2) 830-1407-XX | EAGLE Backplane Fan Connector (J2 B) 830-1410-XX (P6) |
| 830-1413-XX | Card Server B (P2) 830-1407-XX | EAGLE Backplane Fan Connector (J3 B) 830-1410-XX (P6) |

Customer-Supplied Information

The customer's network administrator provides the following information:

- Two **IP** addresses on the provisioning network
- Netmask of the provisioning network
- Default router on the provisioning network

Network Configuration

SM and Sync Network addresses are configured to default values at ExAP or LSMS initialization and should not need to be changed. If they need to be changed for any reason, refer to sections "Network Connection" and "Configuration Menu" in *Administration and LNP Feature Activation* for ELAP, or *Administration Guide* for EPAP.

The provisioning network addresses are configured using the **ExAP** or LSMS user interface configuration menu; refer to "Configuration Menu" in *Administration and LNP Feature Activation* for ELAP or *Administration Guide* for EPAP.

Firewall and Router Filtering Considerations

If a firewall is installed in the provisioning network between the MPS systems or between the MPS system(s) and the provisioning system, it must be configured to allow selected traffic to pass.

For firewall protocol filtering for the various interfaces, see *Administration Guide* for EPAP, *Administration and LNP Feature Activation* for ELAP or *Installation and Upgrade Guide* for LSMS.

B

IMF Network Integration

This chapter provides network integration information for the Integrated Message Feeder (IMF) system.

Introduction

Users have the ability to install the E5-APP-B card IMF System in an existing EAGLE frame. The E5-APP-B cards can be installed into any open slots. The single or dual switches can be installed into an open shelf location.

Network Overview

Network Connections

There are two kinds of network connections: Single Switch and Dual Switch. [Table B-1](#) and [Table B-2](#) illustrate the networks and how they are connected.

Table B-1 Single Switch Cabling Chart

| Cable Part Number | To | From |
|--|--|---|
| 830-1220-XX Serial Roll Over | Server A, TTY S2 Port, 830-1407-XX | Console Server Diag Port (Optional) |
| 830-1220-XX Serial Roll Over | Server A, TTY S0 Port, 830-1407-XX | Console Server, Port 3 |
| 830-1413-XX Fan Alarm Cable | Card/Server A, (P2) 830-1407-XX | EAGLE Backplane Fan Connector (J3), 830-1410-XX |
| 830-1174-XX CAT 5 Straight | Card/Server A Port A (P2) ETH01, 830-1102-XX | Switch 1, Port 1 |
| 830-1174-XX CAT 5 Straight | Card/Server A Port B (P2) ETH03, 830-1102-XX | Switch 1, Port 2 |
| 830-1220-XX Serial Roll Over | Switch 1 Console Port | Console Server, Port 1 |
| 830-1357-XX CAT 5 Straight | Console Server, Ethernet Port | Customer Provisioning Network |
| 830-1357-XX CAT 5 Straight | Switch 1, Port 47 | Customer Provisioning Network |
| Cabling for Servers B, C, D, E, F | | |
| 830-1174-XX CAT 5 Straight | Card/Server B Port A (P2) ETH01, 830-1102-XX | Switch 1, Port 3 |
| 830-1174-XX CAT 5 Straight | Card/Server B Port B (P2) ETH03, 830-1102-XX | Switch 1, Port 4 |
| 830-1174-XX CAT 5 Straight | Card/Server C Port A (P2) ETH01, 830-1102-XX | Switch 1, Port 5 |
| 830-1174-XX CAT 5 Straight | Card/Server C Port B (P2) ETH03, 830-1102-XX | Switch 1, Port 6 |
| 830-1174-XX CAT 5 Straight | Card/Server D Port A (P2) ETH01, 830-1102-XX | Switch 1, Port 7 |
| 830-1174-XX CAT 5 Straight | Card/Server D Port B (P2) ETH03, 830-1102-XX | Switch 1, Port 8 |

Table B-1 (Cont.) Single Switch Cabling Chart

| Cable Part Number | To | From |
|--|----|------|
| STC Cards (E5-ENET-B) | | |
| (2) 830-1174-XX cables per card. (2) 830-1102-XX cable adapters per card. Adapters will be plugged onto each card on the backplane (Port A&B) Cables will plug into the (P3) port on each adapter. | | |
| Fast Copy (E5-ENET-B) | | |
| (2) 830-1174-XX cables per card. Cables will plug into the (P2) port on both existing adapters. | | |
| For the STC or Fast-Copy cards, the A Port of each card will be plugged into the Yellow switch ports (ports 9-27), and the B ports on the Blue ports (ports 28-46) in the single switch configuration. | | |

Figure B-1 IMF Interconnect Single Switch Configuration

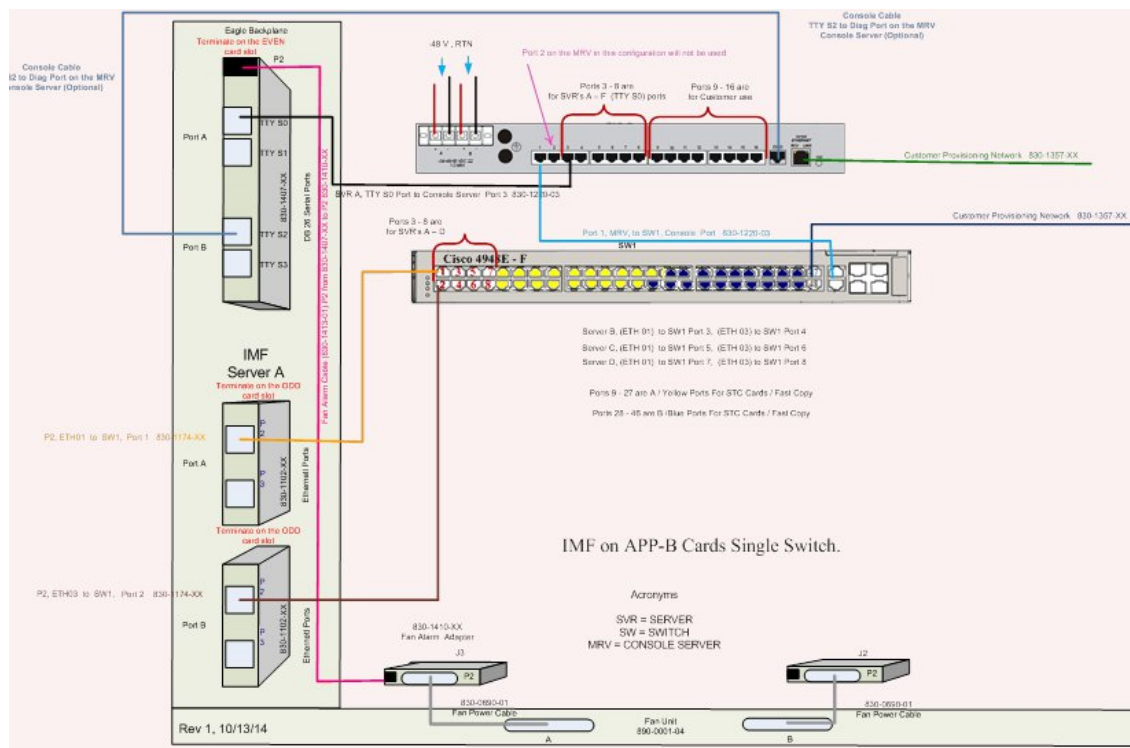

IMF Dual Switch Configuration

Table B-2 Dual Switch Cabling Chart

| Cable Part Number | To | From |
|------------------------------|------------------------------------|---|
| 830-1220-XX Serial Roll Over | Server A, TTY S2 Port, 830-1407-XX | Console Server Diag Port (Optional) |
| 830-1220-XX Serial Roll Over | Server A, TTY S0 Port, 830-1407-XX | Console Server, Port 3 |
| 830-1220-XX Serial Roll Over | SW1 Yellow Port 1 | SW1 Blue, Port 1 |
| 830-1220-XX Serial Roll Over | SW1 Yellow Port 2 | SW1 Blue, Port 2 |
| 830-1413-XX Fan Alarm Cable | Card/Server A, (P2) 830-1407-XX | EAGLE Backplane Fan Connector (J3), 830-1410-XX |

Table B-2 (Cont.) Dual Switch Cabling Chart

| Cable Part Number | To | From |
|--|--|-------------------------------|
| 830-1174-XX CAT 5 Straight | Card/Server A Port A (P2) ETH01, 830-1102-XX | SW1 Yellow, Port 3 |
| 830-1174-XX CAT 5 Straight | Card/Server A Port B (P2) ETH03, 830-1102-XX | SW1 Blue, Port 3 |
| 830-1220-XX Serial Roll Over | SW1 Yellow, Console Port | Console Server, Port 1 |
| 830-1220-XX Serial Roll Over | SW1 Blue, Console Port | Console Server, Port 2 |
| 830-1357-XX CAT 5 Straight | Console Server, Ethernet Port | Customer Provisioning Network |
| 830-1357-XX CAT 5 Straight | SW1 Yellow, Port 47 | Customer Provisioning Network |
| 830-1357-XX CAT 5 Straight | SW1 Blue, Port 47 | Customer Provisioning Network |
| Cabling for Servers B, C, D, E, F | | |
| 830-1174-XX CAT 5 Straight | Card/Server B Port A (P2) ETH01, 830-1102-XX | SW1 Yellow, Port 4 |
| 830-1174-XX CAT 5 Straight | Card/Server B Port B (P2) ETH03, 830-1102-XX | SW1 Blue, Port 4 |
| 830-1174-XX CAT 5 Straight | Card/Server C Port A (P2) ETH01, 830-1102-XX | SW1 Yellow, Port 5 |
| 830-1174-XX CAT 5 Straight | Card/Server C Port B (P2) ETH03, 830-1102-XX | SW1 Blue, Port 5 |
| 830-1174-XX CAT 5 Straight | Card/Server D Port A (P2) ETH01, 830-1102-XX | SW1 Yellow, Port 6 |
| 830-1174-XX CAT 5 Straight | Card/Server D Port B (P2) ETH03, 830-1102-XX | SW1 Blue, Port 6 |
| 830-1174-XX CAT 5 Straight | Card/Server E Port A (P2) ETH01, 830-1102-XX | SW1 Yellow, Port 7 |
| 830-1174-XX CAT 5 Straight | Card/Server E Port B (P2) ETH03, 830-1102-XX | SW1 Blue, Port 7 |
| 830-1174-XX CAT 5 Straight | Card/Server F Port A (P2) ETH01, 830-1102-XX | SW1 Yellow, Port 8 |
| 830-1174-XX CAT 5 Straight | Card/Server F Port B (P2) ETH03, 830-1102-XX | SW1 Blue, Port 8 |
| STC Cards (E5-ENET-B) | | |
| (2) 830-1174-XX cables per card. (2) 830-1102-XX cable adapters per card. Adapters will be plugged onto each card on the backplane (Port A&B) Cables will plug into the (P3) port on each adapter. | | |
| Fast Copy (E5-ENET-B) | | |
| (2) 830-1174-XX cables per card. Cables will plug into the (P2) port on both existing adapters. | | |
| The A Port of each card will be plugged into the Yellow switch ports, and the B Port of each card will be plugged into the Blue switch ports. | | |

Figure B-2 IMF Interconnect Dual Switch Configuration

