

Oracle® Communications Convergent Charging Controller Event Detail Record Reference Guide



Release 15.2

G47598-01

January 2026

The Oracle logo, consisting of a solid red square with the word "ORACLE" in white, uppercase, sans-serif font centered within it.

ORACLE®

Copyright © 2026, Oracle and/or its affiliates.

This software and related documentation are provided under a license agreement containing restrictions on use and disclosure and are protected by intellectual property laws. Except as expressly permitted in your license agreement or allowed by law, you may not use, copy, reproduce, translate, broadcast, modify, license, transmit, distribute, exhibit, perform, publish, or display any part, in any form, or by any means. Reverse engineering, disassembly, or decompilation of this software, unless required by law for interoperability, is prohibited.

The information contained herein is subject to change without notice and is not warranted to be error-free. If you find any errors, please report them to us in writing.

If this is software, software documentation, data (as defined in the Federal Acquisition Regulation), or related documentation that is delivered to the U.S. Government or anyone licensing it on behalf of the U.S. Government, then the following notice is applicable:

U.S. GOVERNMENT END USERS: Oracle programs (including any operating system, integrated software, any programs embedded, installed, or activated on delivered hardware, and modifications of such programs) and Oracle computer documentation or other Oracle data delivered to or accessed by U.S. Government end users are "commercial computer software," "commercial computer software documentation," or "limited rights data" pursuant to the applicable Federal Acquisition Regulation and agency-specific supplemental regulations. As such, the use, reproduction, duplication, release, display, disclosure, modification, preparation of derivative works, and/or adaptation of i) Oracle programs (including any operating system, integrated software, any programs embedded, installed, or activated on delivered hardware, and modifications of such programs), ii) Oracle computer documentation and/or iii) other Oracle data, is subject to the rights and limitations specified in the license contained in the applicable contract. The terms governing the U.S. Government's use of Oracle cloud services are defined by the applicable contract for such services. No other rights are granted to the U.S. Government.

This software or hardware is developed for general use in a variety of information management applications. It is not developed or intended for use in any inherently dangerous applications, including applications that may create a risk of personal injury. If you use this software or hardware in dangerous applications, then you shall be responsible to take all appropriate fail-safe, backup, redundancy, and other measures to ensure its safe use. Oracle Corporation and its affiliates disclaim any liability for any damages caused by use of this software or hardware in dangerous applications.

Oracle®, Java, MySQL, and NetSuite are registered trademarks of Oracle and/or its affiliates. Other names may be trademarks of their respective owners.

Intel and Intel Inside are trademarks or registered trademarks of Intel Corporation. All SPARC trademarks are used under license and are trademarks or registered trademarks of SPARC International, Inc. AMD, Epyc, and the AMD logo are trademarks or registered trademarks of Advanced Micro Devices. UNIX is a registered trademark of The Open Group.

This software or hardware and documentation may provide access to or information about content, products, and services from third parties. Oracle Corporation and its affiliates are not responsible for and expressly disclaim all warranties of any kind with respect to third-party content, products, and services unless otherwise set forth in an applicable agreement between you and Oracle. Oracle Corporation and its affiliates will not be responsible for any loss, costs, or damages incurred due to your access to or use of third-party content, products, or services, except as set forth in an applicable agreement between you and Oracle.

Contents

About This Content

1 EDR Overview

Overview	1
Introduction	1
EDR Generation	1
Introduction	1
About EDR and CDR	1
EDR Tag List	1
Introduction	1
EDR tag versions	1
EDR tags - A	2
EDR tags - B	2
EDR tags - C	3
EDR tags - D	4
EDR tags - E	5
EDR tags - F	5
EDR tags - G	6
EDR tags - H	6
EDR tags - I	6
EDR tags - L	6
EDR tags - M	6
EDR tags - N	7
EDR tags - O	8
EDR tags - P	9
EDR tags - R	9
EDR tags - S	10
EDR tags - T	11
EDR tags - U	12
EDR tags - V	12
EDR tags - W	12

2 Billing Engine and SMS EDR Definitions

Overview	1
Introduction	1
CCS EDR Files	1
Introduction	1
EDR file names	1
EDR lines	2
EDR formats	2
EDR record content	2
Field formats	2
CCS EDR Types	3
Introduction	3
List of EDR types	3
EDR Definition	6
Introduction	6
EDR header fields	6
EDR extra information fields	7
EDR Examples	7
EDRs	8
Introduction	8
Diagram	8
Dataflow	8
Process descriptions	10
EDR triggers	11
CCS-VWS Protocol overview	11
Controlling the flow of EDRs	11
Checking the values in eserv.config	11
Checking the validity of eserv.config	11

3 Operator Updates

Overview	1
Introduction	1
Account Creation using Screens (EDR 2)	1
Mandatory EDR 2 fields	1
Optional EDR 2 fields	1
Example EDR 2	1
Note	2
Account Creation using PI (EDR 2)	2
Mandatory EDR 2 fields	2
Optional EDR 2 fields	2

Example EDR 2	2
Note	2
Account Balance Changes using Screens (EDR 2)	2
Mandatory EDR 2 fields	2
Optional EDR 2 fields	3
Example EDR 2	3
Note	3
Account Balance Changes using PI (EDR 2)	3
Mandatory EDR 2 fields	3
Optional EDR 2 fields	4
Example EDR 2	4
Note	4
Account State Update using Screens (EDR 2)	4
Mandatory EDR 2 fields	4
Optional EDR 2 fields	5
Example EDR 2	5
Note	5
Account State Update using PI (EDR 2)	5
Mandatory EDR 2 fields	5
Optional EDR 2 fields	6
Example EDR 2	6
Note	6
Account Expiry Update using Screens (EDR 2)	6
Mandatory EDR 2 fields	6
Optional EDR 2 fields	7
Example EDR 2	7
Note	7
Balance Expiry Update using Screens (EDR 2)	7
Mandatory EDR 2 fields	7
Optional EDR 2 fields	8
Example EDR 2	8
Note	8
Account Deleted using Screens (EDR 2)	8
Mandatory EDR 2 fields	8
Optional EDR 2 fields	9
Example EDR 2	9
Note	9
Account Activated by System (EDR 2)	9
Mandatory EDR 2 fields	9
Example EDR 2	10
Note	10

4 Voucher Activity

Overview	1
In this chapter	1
Voucher Activity using Screen or PI (EDR 56)	1
Mandatory EDR 56 fields	1
MSISDN additional fields	1
Example EDR 56	1
Note	1

5 Voucher Recharges

Overview	1
Introduction	1
Voucher Recharge Succeeds using Screens (EDR 4,15)	1
Introduction	1
Mandatory EDR 4 fields	1
Optional EDR 4 fields	2
Mandatory EDR 15 fields	2
Optional EDR 15 fields	2
Account Activated additional fields	2
Reload Bonus additional fields	3
MSISDN additional fields	3
Example EDR 4	3
Example EDR 15	3
Note	3
Voucher Recharge Succeeds using IVR (EDR 4,15)	4
Introduction	4
Mandatory EDR 4 fields	4
Optional EDR 4 fields	4
Mandatory EDR 15 fields	4
Optional EDR 15 fields	5
Account Activated additional fields	5
Reload Bonus additional fields	5
MSISDN additional fields	5
Example EDR 4	6
Example EDR 15	6
Note	6
Voucher Recharge Succeeds using PI (EDR 4,15)	6
Introduction	6
Mandatory EDR 4 fields	6
Optional EDR 4 fields	7

Mandatory EDR 15 fields	7
Optional EDR 15 fields	7
Account Activated additional fields	7
Reload Bonus additional fields	8
MSISDN additional fields	8
Example EDR 4	8
Example EDR 15	8
Note	8
Voucher Recharge Succeeds using USSD (EDR 4,15)	8
Introduction	8
Mandatory EDR 4 fields	9
Optional EDR 4 fields	9
Mandatory EDR 15 fields	9
Optional EDR 15 fields	10
Account Activated additional fields	10
Reload Bonus additional fields	10
MSISDN additional fields	10
Example EDR 4	10
Example EDR 15	11
Note	11
Voucher Recharge Fails using Screens or IVR (EDR 4)	11
Introduction	11
Mandatory EDR 4 fields	11
Optional EDR 4 fields	11
MSISDN additional fields	12
Example EDR 4	12
Note	12
Voucher Recharge Fails using Screens or IVR (EDR 15,33)	12
Introduction	12
Mandatory EDR 15 fields	12
Optional EDR 15 fields	12
Mandatory EDR 33 fields	13
Optional EDR 33 fields	13
MSISDN additional fields	13
Example	13
Example EDR 33	13
Note	13
Voucher Type Recharge	14
Introduction	14
Mandatory EDR 47 fields	14
Optional EDR 47 fields	14

6 Rewards

Overview	1
Introduction	1
Reward Application Successful (EDR 16)	1
Introduction	1
Mandatory EDR 16 fields	1
Optional EDR 16 fields	1
Account Activated additional fields	2
Reload Bonus additional fields	2
MSISDN additional fields	2
Example EDR 16	2
Note	2
Reward Application Fails using Screens or IVR (EDR 16)	2
Introduction	2
Mandatory EDR 16 fields	3
Optional EDR 16 fields	3
MSISDN additional fields	3
Example EDR 16 (Remove21)	3
Note	3

7 Voice Calls

Overview	1
Introduction	1
Successful National Call (EDR 1)	1
Mandatory EDR 1 fields	1
Optional EDR 1 fields	2
Partial EDR additional fields	2
Timed-out reservation confirmation additional fields	3
Account Activated additional fields	3
Cross balance type discount additional fields	3
MSISDN additional fields	3
Mobile number portability additional fields	3
Bucket level costs additional field	3
Example EDR 1 for single tariff rated call	4
Example EDR 1 for multi tariff rated call	4
Example Account Activated	4
Example Account Activated - MSISDN	4
Note	4
Commit Reservation (EDR 1)	4
Mandatory EDR 1 fields	4

Example EDR 1 for reservation commit	6
Revoke Reservation (EDR 1)	6
Mandatory EDR 1 fields	6
Example EDR 1 for single tariff rated call	6
Declined National Call	7
Mandatory EDR 1 fields	7
Optional EDR 1 fields	7
Account Activated additional fields	7
MSISDN additional fields	7
Mobile number portability additional fields	7
Example EDR 1 for declined national call	7
Example Account Activated	8
Example MSISDN	8
Note	8
Direct Amount Charge (EDR 6)	8
Mandatory EDR 23 fields	8
Note	9

8 Freeform Recharges

Overview	1
Introduction	1
Freeform Recharge Succeeds using the GUI (EDR 8)	1
Mandatory EDR 8 fields	1
Optional EDR 8 fields	2
MSISDN additional fields	2
Example EDR 8 for freeform succeeds	2
Example MSISDN	2
Note	2
Freeform Recharge Succeeds using PI (EDR 8)	2
Mandatory EDR 8 fields	2
Optional EDR 8 fields	3
MSISDN additional fields	3
Platform dependant additional fields	3
Example EDR 8 for freeform succeeds	3
Example MSISDN	4
Note	4
Freeform Recharge Succeeds using PI (EDR 2)	4
Mandatory EDR 2 fields	4
MSISDN additional fields	4
Example EDR 2 for freeform succeeds	4
Example MSISDN	5

Note	5
Freeform Recharge Fails using PI (EDR 2, 8)	5
Mandatory EDR 2 fields	5
MSISDN additional fields	5
Example EDR 8 for freeform fails	5
Example MSISDN	6
Note	6

9 Credit Card Recharges

Overview	1
Introduction	1
Credit Card Recharge Succeeds using Screens (EDR 9)	1
Mandatory EDR 9 fields	1
MSISDN additional fields	1
Example EDR 9 for cc recharge	2
Note	2
Credit Card Recharge Succeeds using PI (EDR 9)	2
Mandatory EDR 9 fields	2
Optional EDR 9 fields	2
MSISDN additional fields	2
Example EDR 9 for cc succeeds	3
Note	3

10 Voucher Freeform Recharges

Overview	1
Introduction	1
Voucher Freeform Recharge Succeeds using Screens (EDR 10)	1
Mandatory EDR 10 fields	1
Mandatory EDR 53 fields	1
MSISDN additional fields	1
Example EDR 10 for voucher ff succeeds	2
Note	2

11 Voucher Batch Deletion

Overview	1
Introduction	1
Voucher Batch Deletion using Screens (EDR 53)	1
Mandatory EDR 53 fields	1
Example EDR 53 (Remove91)	1

Note	2
------	---

12 Periodic Charge

Overview	1
Introduction	1
Periodic Charge Recharge Succeeds (EDR 49)	1
Mandatory EDR 49 fields	1
Optional EDR 49 fields	1
Periodic Charge Named Event Succeeds (EDR 49)	2
Mandatory EDR 49 fields	2
Optional EDR 49 fields	2
Periodic Charge Recharge Fails (EDR 49)	2
Mandatory EDR 49 fields	2
Periodic Charge Named Event Fails (EDR 49)	3
Mandatory EDR 49 fields	3
Change Subscription State Succeeds (EDR 52)	3
Mandatory EDR 52 fields	3
Optional EDR 52 fields	4
Change Subscription State Fails (EDR 52)	4
Mandatory EDR 52 fields	4
Optional EDR 52 fields	4

13 Web Initiated Recharges

Overview	1
Introduction	1
Web Initiated Recharge Succeeds using PI (EDR 8)	1
Mandatory EDR 8 fields	1
Optional EDR 8 fields	1
Example EDR 8 for web	2
Note	2

14 PI Promotional Recharges

Overview	1
Introduction	1
PI Promotional Recharge Succeeds using PI (EDR 2)	1
Mandatory EDR 2 fields	1
MSISDN additional fields	1
Example EDR 2 for pi promo	1

15 Friends & Family, Friends & Destination Config Change

Overview	1
Introduction	1
F&F/F&D Change Succeeds using IVR (EDR 5)	1
Mandatory EDR 5 fields	1
Optional EDR 5 fields	1
Account Activated additional fields	2
MSISDN additional fields	2
Example EDR 5 for fnf	2
Note	2
F&F/F&D Change Fails using IVR (EDR 5)	2
Mandatory EDR 5 fields	2
MSISDN additional fields	2
Example EDR 5 for fnf (Remove1)	3
Note	3
F&F/F&D Change Succeeds using PI (EDR 28)	3
Mandatory EDR 28 fields	3
MSISDN additional fields	3
Example EDR 28 for fnf	3
Note	3
F&F/F&D Change Fails using PI (EDR 5)	4
Mandatory EDR 5 fields	4
MSISDN additional fields	4
Example EDR 5 for fnf (Remove2)	4
Note	4
F&F/F&D New Entry Succeeds using PI (EDR 5)	4
Mandatory EDR 5 fields	4
Optional EDR 5 fields	5
MSISDN additional fields	5
Note	5

16 Call Barring Config Change

Overview	1
Introduction	1
Call Barring Change Succeeds using PI (EDR 30)	1
Mandatory EDR 30 fields	1
MSISDN additional fields	1
Example EDR 30 for call barring	1

Note	1
------	---

17 Change 'Disable Incoming Calls when Roaming' Flag

Overview	1
Introduction	1
DICWR Flag Change Succeeds using Screens (EDR 29)	1
Mandatory EDR 29 fields	1
MSISDN additional fields	1
Example EDR 29-	1
Note	1
DICWR Flag Change Succeeds using PI (EDR 29)	2
Mandatory EDR 29 fields	2
Example EDR 29	2
MSISDN additional fields	2
Note	2

18 PI Adds Service Charge

Overview	1
Introduction	1
PI Adds Service Charges Succeeds using PI (EDR 2,5)	1
Mandatory EDR 2 fields CCSSC1	1
Optional EDR 2 fields CCSSC1	1
Mandatory EDR 5 fields CCSSC1	2
Optional EDR 5 fields CCSSC1	2
Mandatory EDR 5 fields CCSSC1	2
Optional EDR 5 fields CCSSC1	3
Mandatory EDR 2 fields CCSSC2	3
Mandatory EDR 2 fields CTLSC1	4
Mandatory EDR 5 fields CTLSC1	4
Optional EDR 5 fields CTLSC1	5
Mandatory EDR 5 fields CTLSC1	5
Optional EDR 5 fields CTLSC1	6
Mandatory EDR 2 fields CTLSC2	6
Mandatory EDR 2 fields CTLSC2	7
MSISDN additional fields	7
MSISDN example	7
Note	8

19 Product Type Swap

Overview	1
Introduction	1
PTS Succeeds using Screens (EDR type 31)	1
Mandatory EDR 31 fields	1
MSISDN additional fields	1
Example EDR 31 (Remove1)	1
Note	1
PTS Succeeds using PI (EDR type 31)	2
Mandatory EDR 31 fields	2
MSISDN additional fields	2
Example EDR 31	2
Note	2
PTS Succeeds using the GUI (EDR 31, 32)	2
Introduction	2
Mandatory EDR 31 fields	2
Mandatory EDR 32 fields	3
Optional EDR 32 fields	3
Account Activated additional fields	3
MSISDN additional fields	3
Example EDR 31 (Remove2)	4
Example EDR 32	4
Account activated example	4
Example Account Activated - MSISDN	4
Note	4
PTS Succeeds using IVR (EDR 31, 32)	4
Introduction	4
Mandatory EDR 31 fields	4
Mandatory EDR 32 fields	5
Optional EDR 32 fields	5
Account Activated additional fields	5
MSISDN additional fields	5
Example EDR 31 (Remove3)	6
Example EDR 32 (Remove2)	6
Account activated example	6
Example MSISDN	6
Note	6
PTS Fails using the GUI (EDR 32)	6
Mandatory EDR 32 fields	6
MSISDN additional fields	7
Example EDR 32 (Remove91)	7

Example MSISDN	7
Note	7
PTS Fails using IVR (EDR 32)	7
Mandatory EDR 32 fields	7
MSISDN additional fields	7
Example EDR 32 (Remove5)	8
Example MSISDN	8
Note	8

20 Read Secret Code

Overview	1
Introduction	1
Read Secret Code Change Fails using IVR (EDR 33)	1
Mandatory EDR 33 fields	1
Optional EDR 33 fields	1
MSISDN additional fields	1
Example EDR 33 (Remove1)	1
Note	1

21 Expiration

Overview	1
Introduction	1
Balance Expiry (EDR 3)	1
Mandatory EDR 3 fields	1
Optional EDR 3 fields	1
MSISDN additional fields	1
Example EDR 3 (Remove1)	1
Example MSISDN	2
Note	2
Account Expiry (EDR 3)	2
Mandatory EDR 3 fields	2
Optional EDR 3 fields	2
MSISDN additional fields	2
Example EDR 3 (Remove91)	2
Example MSISDN	2
Note	2
PI Delete (EDR 2)	3
Mandatory EDR 2 fields	3
MSISDN additional fields	3

22 Roaming Voice Calls

Overview	1
Introduction	1
Successful Roaming Call (EDR type 1)	1
Introduction	1
Mandatory EDR 1 fields	1
Optional EDR 1 fields	2
Partial EDR additional fields	2
Timed-out reservation confirmation additional fields	2
Account Activated additional fields	2
Cross balance type discount additional fields	3
MSISDN additional fields	3
Example EDR 1 (Remove8)	3
Example Account Activated	3
Example MSISDN	3
Note	4
Declined Roaming Call (EDR type 1)	4
Introduction	4
Mandatory EDR 1 fields	4
Optional EDR 1 fields	4
Account Activated additional fields	4
MSISDN additional fields	5
Mobile number portability additional fields	5
Example EDR 1 (Remove9)	5
Example Account Activated	5
Example MSISDN	5
Note	5
Successful Roaming Call (EDR type 11)	5
Introduction	5
Mandatory EDR 11 fields	6
Optional EDR 11 fields	6
Partial EDR additional fields	7
Timed-out reservation confirmation additional fields	7
Account Activated additional fields	7
Cross balance type discount additional fields	7
MSISDN additional fields	7
Mobile number portability additional fields	8
Example EDR 11 (Remove1)	8
Note	8

Declined Roaming Call (EDR type 11)	8
Introduction	8
Mandatory EDR 11 fields	8
Optional EDR 11 fields	9
Account Activated additional fields	9
Mobile number portability additional fields	9
MSISDN additional fields	9
Example EDR 11	9
Note	9

23 Data and Video Calls (EDRs 50 and 51)

Overview	1
Introduction	1
About Type 50 and 51 EDRs	1

24 Prepaid Data

Overview	1
Introduction	1
GPRS Content Charge Succeeds (EDR 5)	1
Mandatory EDR 5 fields	1
Optional EDR 5 fields	1
Account Activated additional fields	2
Example EDR 5 (Remove3)	2
Note	2
GPRS Content Charge Fails (EDR 5)	2
Mandatory EDR 5 fields	2
Example EDR 5 (Remove4)	2
Note	3
GPRS Volume or Duration Charge Succeeds (EDR 14)	3
Mandatory EDR 14 fields	3
Account Activated additional fields	3
Example EDR 14	3
Note	4
GPRS Volume or Duration Charge Fails (EDR 5)	4
Mandatory EDR 5 fields	4
Example EDR 5 (Remove3)	4
Note	4

25 SMS-MO

Overview	1
Introduction	1
In this chapter	1
National SMS-MO Succeeds (EDR 12,13)	1
Introduction	1
Mandatory EDR 12 fields	1
Optional EDR 12 fields	2
Mandatory EDR 13 fields	2
Optional EDR 13 fields	3
Account Activated additional fields	3
Cross balance type discount additional fields	3
Mobile number portability additional fields	3
MSISDN additional fields	3
Example EDR 12 (Remove10)	3
Example Account Activated	4
Example MSISDN	4
Note	4
National SMS-MO Fails (EDR 1, 5,12,13)	4
Introduction	4
Mandatory EDR 1 and 13 fields	4
Mandatory EDR 5 and 12 fields	5
Account Activated additional fields	5
Mobile number portability additional fields	5
MSISDN additional fields	5
Example EDR 5 (Remove10)	5
Example MSISDN	5
Note	6
Roaming SMS-MO Succeeds (EDR 12,13)	6
Introduction	6
Mandatory EDR 12 fields	6
Optional EDR 12 fields	6
Optional EDR 13 fields	7
Account Activated additional fields	7
Example Account Activated	7
Cross balance type discount additional fields	7
Mobile number portability additional fields	7
MSISDN additional fields	8
Example EDR 13 (Remove1)	8
Example MSISDN	8
Note	8

Roaming SMS-MO Fails (EDR 1,5,12,13)	8
Introduction	8
Mandatory EDR 1 and 13 fields	8
Mandatory EDR 5 and 12 fields	9
Account Activated additional fields	9
Mobile number portability additional fields	9
MSISDN additional fields	9
Example EDR 13 (Remove5)	9
Example Account Activated	9
Example MSISDN	10
Note	10

26 SMS-MT

Overview	1
Introduction	1
National SMS-MT Succeeds (EDR 12,13)	1
Introduction	1
Mandatory EDR 12 fields	1
Optional EDR 12 fields	2
Mandatory EDR 13 fields	2
Optional EDR 13 fields	2
Account Activated additional fields	3
Cross balance type discount additional fields	3
Mobile number portability additional fields	3
MSISDN additional fields	3
Example MSISDN	3
Note	3
National SMS-MT Fails (EDR 1,5,12,13)	4
Introduction	4
Mandatory EDR 1 and 13 fields	4
Account Activated additional fields	4
Mobile number portability additional fields	4
Mandatory EDR 5 and 12 fields	4
MSISDN additional fields	5
Example EDR 5 (Remove12)	5
Example MSISDN	5
Note	5
Roaming SMS-MT Succeeds (EDR 12,13)	5
Introduction	5
Mandatory EDR 12 fields	5
Mandatory EDR 13 fields	6

Optional EDR 13 fields	7
Account Activated additional fields	7
Cross balance type discount additional fields	7
Mobile number portability additional fields	7
MSISDN additional fields	7
Example EDR 13 (Remove18)	7
Example MSISDN	8
Note	8
Roaming SMS-MT Fails (EDR 1,5,12,13)	8
Introduction	8
Mandatory EDR 1 and 13 fields	8
Account Activated additional fields	8
Mobile number portability additional fields	8
Mandatory EDR 5 and 12 fields	9
MSISDN additional fields	9
Example Account Activated	9
Example MSISDN	9
Note	9

27 Wallet Credit Transfer

Overview	1
Introduction	1
Wallet Credit Transfer Succeeds or Fails (EDR 47)	1
Mandatory EDR 47 fields	1
Optional EDR 47 fields	1
Cost of Credit Transfer Succeeds (EDR 5)	1
Mandatory EDR 5 fields	1
Optional EDR 5 fields	2
Example EDR 5 (Remove17)	2
Cost of Credit Transfer Fails (EDR 5)	2
Mandatory EDR 5 fields	2

28 Wallet Migration

Overview	1
Introduction	1
Wallet Migration (EDR 54)	1
Mandatory EDR 54 fields	1
Example EDR 54	1
Note	2

29 Wallet Life Cycle

Overview	1
Introduction	1
Wallet Life Cycle (EDR 55)	1
Mandatory EDR 55 fields	1
Optional EDR 55 fields	1
Note	1

30 Credit Card Updates

Overview	1
Introduction	1
Credit Card EDRs (Types 57, 58, 59, 60, 61, 62, 63, and 64)	1
About EDRs for Operator Updates to Subscriber Credit Card Records	1
Mandatory Credit Card EDR Fields (Type 57 to Type 64)	1

31 Billing Engine Control Plan Invocation

Overview	1
Introduction	1
Control Plan Service Invoke (EDR 7)	1
Mandatory EDR 7 fields	1
Note	1

32 CCS EDR Tag Definitions

Overview	1
Introduction	1
CCS EDR Tag List	1
EDR tags	1
ACCOUNT_TYPE (Product Type ID)	1
ACCT_ID (changed wallet ID)	1
ACCT_REF_ID (changed account ID)	1
ACS_CUST_ID (ACS Customer ID)	2
ACTION (voucher activity)	2
ACTION_DETAIL (voucher activity)	2
ACTIVATION_DATE (account activation date)	3
ADJUSTMENT (generated by an adjustment)	3
APPLICATION_DESC (application freeform)	3
BAD_PINS (number of attempts)	4
BALANCE_EXPIRIES (period hours)	4
BALANCE_NAMES	4

BALANCE_TYPES (account changed or created)	4
BALANCE_TYPES (account changed or created) - mid call rate change	5
BALANCE_TYPES (existing account)	5
BALANCES (pre-call or account creation)	6
BALANCES (pre-call or account creation) - mid call rate change	6
BALANCES (pre-transaction account balances)	7
BARCODE (voucher details)	7
BARRED_LIST_TYPE (description)	7
BATCH_DESCRIPTION (for voucher batch)	7
BEARER_TYPE (bearer type for promotions)	7
BILLING_ENGINE_ID (BE where account resides)	8
BONUS_TYPE (name)	8
BUCKET_IDS (within balance type recharged)	8
BUCKET_LEVEL_COSTS	8
CALLED_NUMBER	9
CARD DESIGN (voucher details)	9
CASCADE (always empty for pi)	9
CASCADE_ID (balance type cascade IDs)	9
CASCADE_ID (balance type cascade IDs) - mid call rate change	10
CBTD_BALANCE_TYPES (list to apply to discounts)	10
CBTD_BALANCE_TYPES (list to apply to discounts) - mid call rate change	11
CBTD_BALANCES (value for each cross balance type)	11
CBTD_BALANCES (value for each cross balance type) - mid call rate change	11
CBTD_CASCADE_ID (used for this call)	12
CBTD_CASCADE_ID (used for this call) - mid call rate change	12
CBTD_COSTS (costs applied to each cross balance type)	12
CBTD_COSTS (costs applied to each cross balance type) - mid call rate change	12
CBTD_COSTS_RND_REM (rounding remainder of cross balance CBTD_COSTS)	13
CBTD_DISCOUNTS (discounts applied to balance types)	13
CBTD_DISCOUNTS (discounts applied to balance types) - mid call rate change	13
CDR_TYPE (reason for record generation)	14
CHANNEL (for rewards)	14
CHARGE_EXPIRY (new periodic charge expiry)	14
CHARGE_NAME (of periodic charge)	15
CLI (initiating call number)	15
CLI (initiating call number) - mid call rate change	15
CLI (for the account that will be changed)	15
CLI (roaming initiating call number)	16
COMPONENT (from pi command reference)	16
CONTROL_PLAN (name of invoked control plan)	16
COSTS (rated calls)	16
COSTS (rated calls) - mid call rate change	17

COSTS_RND_REM (rounding remainder of balance COSTS)	17
CS (call status, S or D)	17
CT_NAME (credit transfer)	18
CT_TYPE (credit transfer)	18
CUG_NAME (closed user group)	18
DICWR (Disable Incoming Calls When Roaming)	18
DISCOUNT (always zero for pi)	19
DISCOUNT_TYPE (applied to this call)	19
DISCOUNT_TYPE (applied to this call)	19
DISCOUNT_TYPE (applied to this call) - service discount	19
DISCOUNTS (for each named event)	20
DISCOUNTS (rated calls)	20
DISCOUNTS (rated calls) - mid call rate change	21
DISPLAY_NUMBER (credit card)	21
DISPLAY_SPEND_RATIO (Balance Type Display to Spend Ratio)	22
DISTRIBUTOR_CHANNEL (voucher details)	22
DOMAIN_MIGRATION	22
DURATION (call length)	22
DURATION_CHARGED	22
DURATION_DELTA	23
END_CALL_REASON	24
EVENT_CLASS (list of classes used)	24
EVENT_COST (for each named event)	24
EVENT_COUNT (for each named event)	25
EVENT_NAME (list used for this call)	25
EVENT_TIME_COST (for a named event)	25
EXCEEDED_BALANCE_NAMES	25
EXCEEDED_BALANCE_TYPES	26
EXCEEDED_VALUES	26
EXPIRED_WALLET (ID of expired wallet)	26
EXPIRY_DATE (for a credit card)	26
FCA (final call address)	26
FAILED_BALANCE_NAMES	27
FAILED_BALANCE_TYPES	27
FREE_TEXT_FIELD_1 (voucher details)	27
FREE_TEXT_FIELD_2 (voucher details)	27
FREE_TEXT_FIELD_3 (voucher details)	27
HOST (initiating credit transfer)	28
IGNORE_BARRED (ignore numbers in call barring list)	28
LAST_RECORD_DATE	28
LENGTHS (rate durations)	28
LENGTHS (rate durations) -1end duration	28

LENGTHS (rate durations) - mid call rate change	29
LOCADD (additional configuration prefixes)	29
MAX_CHARGE (for this call)	29
MAX_CHARGE (for this call) - mid call rate change	30
MAX_CONCURRENT (maximum concurrent accesses allowed)	30
MFILE (name)	30
MID_SESSION	30
MSISDN (account calling number)	31
MSISDN (subscriber ids)	31
NACK (freeform recharge list)	31
NACK (long list of codes)	32
NACK (short list of codes)	32
NAME_ON_CARD (for a credit card)	33
NEW_ACCOUNT (ID of account type)	33
NEW_ACCT_EXPIRY (date after account deleted)	33
NEW_ACCT_EXPIRY (date after update)	33
NEW_ACCT_EXPIRY (date after recharge)	34
NEW_ACCT_STATE (always active - A)	34
NEW_ACCT_STATE (always frozen - F)	34
NEW_ACCT_STATE (always preuse - P)	34
NEW_ACCT_STATE (always terminated - T)	34
NEW_ACCT_STATE (after update)	34
NEW_ACCT_TYPE (ID of account after recharge)	35
NEW_ACCT_TYPE (prod type swap)	35
NEW_ACTIVE_SVC (account type)	35
NEW_BALANCE_EXPIRIES (date after balance update)	35
NEW_BALANCE_EXPIRIES (dates after voucher recharge)	36
NEW_BARRED_LIST (of call barring numbers)	36
NEW_CHARGE_STATE (periodic charge subscription state)	36
NEW_FD (friends destination number)	36
NEW_FF (list of friends and family numbers)	36
NEW_LAST_USE (date last used)	37
NEW_WLC_PERIOD (after update)	37
NEW_WLC_PLAN (Id)	37
NUMBER (voucher number)	37
OGEO_ID (originating geo node id)	37
OLD_ACCOUNT (ID of account type)	37
OLD_ACCT_EXPIRY (dates before update)	38
OLD_ACCT_EXPIRY (date before recharge)	38
OLD_ACCT_STATE (always active - A)	38
OLD_ACCT_STATE (before update)	38
OLD_ACCT_STATE (pre-call)	39

OLD_ACCT_STATE (P or D before update)	39
OLD_ACCT_TYPE (ID of account before recharge)	39
OLD_ACCT_TYPE (prod type swap)	39
OLD_ACTIVE_SVC (account type)	39
OLD_BALANCE_EXPIRIES (dates before balance update)	40
OLD_BALANCE_EXPIRIES (dates before voucher recharge)	40
OLD_BARRED_LIST (of call barring numbers)	40
OLD_CHARGE_EXPIRY (periodic charge expiry date changes)	40
OLD_CHARGE_STATE (periodic charge subscription state)	40
OLD_FD (friends destination number)	41
OLD_FF (list of friends and family numbers)	41
OLD_WLC_PERIOD (before update)	41
OLD_WLC_PLAN (Id)	41
OPERATOR_RELEASED (commit/revoke reservation)	41
OVERDRAWN_AMOUNT (take Balance Negative)	42
OVERRIDDEN_TARIFF_PLAN (ID)	42
PC_TYPE (periodic charge type)	42
PI (logon name and IP address)	42
PORTED (name of porting carrier)	42
PRO_RATE (periodic charge subscription)	43
PROVISIONING_DATE (voucher details)	43
PURCHASING_ACCT_ID (purchasing wallet ID)	43
PURCHASING_MSISDN (purchasing CLI)	43
RATES (rated calls)	44
RATES (rated calls) - mid call rate change	44
REASON (change reason)	45
RECIPIENT_ACCT_ID (receiving wallet ID)	45
RECIPIENT_MSISDN (receiving CLI)	45
RECORD_DATE (date edr created)	46
REDEEMING_ACCT_REF (ID of account)	46
REDEEMING_ACCT_TYPE (name of account type)	46
REFERENCE (credit card reference, always cc)	46
REFERENCE (operator freeform)	46
REFERENCE (operator freeform)	47
REFERENCE (OSA Bonus)	47
REFERENCE (from pi reference)	47
REFERENCE (voucher freeform)	47
REFERENCE (web site reference - ws)	47
RELC (inap release cause)	48
RELOAD_BONUS (promotion name)	48
RELOAD_BONUS_AMOUNT (amount applied)	48
RELOAD_BONUS_EXPIRY (date remaining bonus expires)	48

RELOAD_BONUS_LEFT (bonus amount remaining)	48
REMAINING_CHARGE (partial Charge)	49
RESULT (general cause)	49
RESULT (frozen or suspended)	49
RESULT (pi failure)	49
RESULT (voucher redemption, always Success)	50
RESULT (web - success)	50
RETAIL_CHANNEL (voucher details)	50
REVERSE_CHARGE (generated by a reverse charge)	50
REWARD (ID)	50
REWARD_AMOUNTS (value of reward)	50
REWARD_CATEGORY	51
REWARD_TYPES (balance types getting reward)	51
RNCF (Reservation Not Charged For)	51
ROAMING_COUNTRY (name)	51
ROAMING_TYPE (of call)	52
SCENARIO (voucher scenario number)	52
SCP_ID (where call originated)	52
SEQUENCE_NUMBER (call identifier)	52
SERVICE_HANDLE (invoked service handle)	52
SERVICE_RESPONSE (from service function)	53
SESSION_SEQUENCE	53
STATE (of recharge)	53
SVC_ID (single tariff rated calls)	53
TARIFF_CODE (name)	54
TCE (ccs time call ended)	54
TCS (ccs time call started)	54
TERMINAL (Network ID)	54
TEXT (voucher details)	54
TGEO_ID (terminating geo node id)	55
TIMED_OUT (reservation confirmation)	55
TN (called number)	55
TN (roaming called number)	55
TYPE_DESCRIPTION (voucher type)	55
USER (operator logon name)	56
VOUCHER (ID of redeemed voucher)	56
VOUCHER (serial number of redeemed voucher - 3.1.5)	56
VOUCHER_BATCH (for voucher batch)	56
VOUCHER_NUMBER (redeemed voucher)	56
VOUCHER_TYPE (name)	56
WALLET_DELETED (always success - Y)	57
WALLET_TYPE (ID of wallet changed)	57

33 SLC Generated EDRs

Overview	1
Introduction	1
ACS EDRs	1
EDR generation	1
Diagram	1
EDR File Names	2
EDR collection	3
File format	3
Example slee_acs EDRs	4
ACS EDR tags	4
AIDL (played announcement ID list)	4
BCOR (balance cascade override)	5
BFT (billing failure treatment)	5
CA (called address)	5
CAET (call attempt elapsed time)	6
CBAT (connected by attempt termination)	6
CC (carrier code)	6
CCET (call connect elapsed time)	6
CCTS (call connect timestamp)	6
CGN (calling network number)	7
CGNA (global calling network address)	7
CGNN (calling party nature of number)	7
CID (slee call ID)	7
CLI (calling logical number)	8
CPC (calling party category)	8
CPN (control plan name)	8
CPNI (calling private network ID)	8
CPNN (called party nature of number)	9
CPPI (calling party presentation restricted indicator)	9
CS (acs connect status)	9
CUST (customer database ID)	10
DISC (discount override)	10
EXT(0-9) (extension buffer contents)	10
FATS (first announcement timestamp)	11
HTS (hunting timestamp)	11
LAC (last account code used)	11
LGID (language ID)	11
LPN (most recent pin entered)	12

MCOR (maximum charge override)	12
NOAT (number of attempt terminations)	12
NT (network type)	12
OA (sccp originating address)	13
OCPI (original called party)	13
OTI (originating transaction ID)	13
PCNA (calling private network address)	13
PTNA (private terminating network address)	13
RELC (acs release cause)	14
SK (service key)	14
SN (service number)	14
TCE (acs time call ended)	14
TCS (acs time call started)	15
TFN (tracked feature node list)	15
TGNA (global terminating network address)	16
TN (acs termination number)	16
TPNI (terminating private network ID)	17
TPO (tariff plan override)	17
WALR (wallet reference)	17
DCD EDRs	17
EDR Generation	17
DCD EDR Tags	17
DIA_RC (result code)	18
DIA_REQ (current session message number)	18
DIA_SID (session id)	18
DIA_TIME (time ccr sent)	18
Custom Tag Names	18
Example EDRs	19
SCA EDRs	20
EDR collection	20
Field formats	20
EDR fields	20
CDR_TYPE (sca reason for record generation)	20
DURATION (session duration)	21
FROM (sip message from header)	21
METHOD (sip method of request)	21
REQUEST_URI (uri request content)	21
TIMESTAMP (creation timestamp of sca edr)	21
TO (sip to header content)	22
NP EDRs	22
Introduction	22
EDR collection	22

NP EDR files	22
EDR fields	23
NP ACS tags	23
Example ACS EDRs	24
LCR EDR tags	24
CALLINGNOA (noa of callingnum)	25
CALLINGNUM (lcr set calling number)	25
CARRIERNAME (carrier name)	25
CARRIERPOS (position of carrier name in hunt list)	25
ORIGTRUNK (idp location number content)	26
PID (unix process ID)	26
PTI (product type ID)	26
ROUTEDEST (routing destination for call)	26
TIME (creation timestamp of lcr edr)	26
TNNOA (noa of terminating number)	27
TNNUM (lcr terminating number)	27
Example LCR EDRs	27
Messaging Manager EDRs	27
EDR collection	27
Diagram	27
File name and location	28
File format	28
Field formats	28
Messaging Manager EDR tags	29
ADAP (adaptations)	29
ALPH (alphabet name)	29
APPA (auxiliary applications)	30
APPD (destination application)	30
APPR (reply application)	30
ASAD (ip of originating asp)	30
ASPDF (asp definition)	30
ASPID (inbound and outbound path)	31
AXAD (ip connections from asp)	31
BILLID	31
CCLS (mms content class)	31
CHPY (charged party)	32
CT (mime type)	32
DADR (destination address)	32
DATE (timestamp sms sent to mmx)	32
DELTS (timestamp of delivery attempt)	33
DIMSI (destination imsi)	33
DISTS (timestamp of discard)	33

DLOC (terminating party location information)	33
DLVR (message delivered flag)	33
DPATH (delivery path)	34
DRM (drm content)	34
DSCA (destination service center address)	34
DSCGT (destination gt)	34
DSTL (destination gt of fda msc)	34
EDELTA (earliest delivery time)	35
ESN (electronic serial number)	35
GPRS (general packet radio service)	35
IPRI (incoming protocol value)	35
IPRN (incoming protocol name)	35
ITS (incoming tele service)	36
MMC (mms message class)	36
MSCA (smc address)	36
MSGD (message destination)	36
MSGR (message reference number)	36
MTYP (message type)	37
NRQ (status report requested for message)	37
NRQD (emi with defined nrq)	37
OADR (originating address)	37
OAID (originating adapter id)	38
OCAU (acs cause value)	38
OIMSI (originating imsi)	38
OIPA (originating ip address)	38
OLOC (originating party location information)	38
OPRI (outgoing priority)	39
OPRN (output protocol name)	39
OPRT (originating port number)	39
OSA (originator system address)	39
OTS (outgoing tele service)	39
PERR (protocol specific error)	39
PRES (terminating adapter response)	40
PRID (protocol identifier)	40
RECN (current recipient number)	40
RECT (number of recipients)	40
RESL (submit result)	41
RRR (read reply request)	41
SCA (service center address)	41
SCRID (screening rule id)	41
SEGN (message segment number)	41
SEGR (concatenated message reference)	42

SEGT (total message segments)	42
SRCL (source location)	42
SRQ (storage requested)	42
SSAD (ip of originating smsc)	42
SSRID (screening sub-rule id)	42
SSTN (smpp service type)	43
STRR (status report request)	43
SUBJ (message subject)	43
SUB_STATUS (subscriber status)	43
SV (sender visibility)	44
TAID (terminating adapter id)	44
TCAU (acs terminate cause value)	44
THRD (throttled flag)	44
TLEN (length of user data in characters)	44
TYPE (type of edr)	44
ULEN (length of user data)	45
USRD (user data)	45
VP (validity period)	45
Multiple field occurrences	45
Example EDR 1 (Remove11)	46
Example EDR 2 (Remove19)	46
Example EDR 3 (Remove15)	46
EDR address format	46
UIS EDRs	47
Example of UIS EDR	47
UIS EDR Tags	48
IMSI	48
MSISDN	48
dialledString (Dialled String)	48
SAN (Subscriber Access Number)	48
servicelf (Service Interface)	49
operator	49
fastAccess (Fast Access)	49
interactions (Number of User Interactions)	49
startTime (Start Time)	49
sessionDuration (Session Duration)	50
sessionTimeout (Session Cutoff Timer Expiry)	50
ssfTimeout (SSF Timer Expiry)	50
inactivityTimeout (Inactivity Timer Expiry)	50

About This Content

This document explains the final format of all existing types of Event Detail Records (EDRs) created on the Voucher and Wallet Server and the SMS.

Audience

This guide is written primarily for system administrators of Oracle products.

Although there are no prerequisites for using this guide, familiarity with the target platform would be an advantage.

Documentation Accessibility

For information about Oracle's commitment to accessibility, visit the Oracle Accessibility Program website at <http://www.oracle.com/pls/topic/lookup?ctx=acc&id=docacc>.

Access to Oracle Support

Oracle customers that have purchased support have access to electronic support through My Oracle Support. For information, visit <http://www.oracle.com/pls/topic/lookup?ctx=acc&id=info> or visit <http://www.oracle.com/pls/topic/lookup?ctx=acc&id=trs> if you are hearing impaired.

Related Resources

The following documents are related to this document:

- Charging Control Services Technical Guide
- Charging Control Services User's Guide
- Voucher Manager User's Guide
- Feature Nodes Reference Guide

Conventions

The following text conventions are used in this document.

Convention	Meaning
boldface	Boldface type indicates graphical user interface elements associated with an action, or terms defined in text or the glossary.
<i>italic</i>	Italic type indicates book titles, emphasis, or placeholder variables for which you supply particular values.
monospace	Monospace type indicates commands within a paragraph, URLs, code in examples, text that appears on the screen, or text that you enter.

1

EDR Overview

Overview

Introduction

This chapter explains the Convergent Charging Controller processes that generate Event Detail Records (EDR).

EDR Generation

Introduction

EDRs are generated by:

- CCS - on the:
- SLC (refer to *SLC Generated EDRs*).
- Billing engine and the SMS (refer to *Billing Engine and SMS EDR Definitions*).
- ACS - slee_acs on the SLC. Refer to *ACS EDRs*.
- Messaging Manager - xmsTrigger on the SLC. Refer to *Messaging Manager EDRs*.
- Diameter Charging Driver - slee_acs on the SLC. Refer to *DCD EDRs*.

About EDR and CDR

The industry standard abbreviation for a record of the event detail type is EDR (Event Detail Record). Previously, in Oracle documentation, the abbreviation CDR (Call Data Record) was used. Over time, EDR will replace CDR in this and other Oracle documentation.

EDR Tag List

Introduction

The following list identifies all the EDR tags documented within this guide.

EDR tag versions

Where a tag is redefined, for a new version of software, both the new and old definition is included. Where the new version is used in a CCS EDR, the tag list will also have both the old and new tags listed.

EDR tags - A

This list covers all application EDRs defined within this guide, starting with the letter A.

- *ACCOUNT_TYPE* (Product Type ID)
- *ACCT_ID* (changed wallet ID)
- *ACCT_REF_ID* (changed account ID)
- *ACS_CUST_ID* (ACS Customer ID)
- *ACTION* (voucher activity)
- *ACTION_DETAIL* (voucher activity)
- *ACTIVATION_DATE* (account activation date)
- *ADJUSTMENT* (generated by an adjustment)
- *AIDL* (played announcement ID list)
- *ALPH* (alphabet name)
- *ANS_TM* (answer time)
- *APPLICATION_DESC* (application freeform)
- *ASAD* (ip of originating asp)
- *ASPDF* (asp definition)
- *ASPID* (inbound and outbound path)
- *AXAD* (ip connections from asp)

EDR tags - B

This list covers all application EDRs defined within this guide, starting with the letter B.

- *BAD_PINS* (number of attempts)
- *BALANCE_EXPIRIES* (period hours)
- *BALANCE_TYPES* (account changed or created)
- *BALANCE_TYPES* (account changed or created) - mid call rate changes
- *BALANCE_TYPES* (existing account)
- *BALANCES* (pre-call or account creation)
- *BALANCES* (pre-call or account creation) - mid call rate changes
- *BALANCES* (pre-transaction account balances)
- *BARRED_LIST_TYPE* (description)
- *BATCH_DESCRIPTION* (for voucher batch)
- *BARCODE* (voucher details)
- *BCOR* (balance cascade override)
- *BEARER_TYPE* (bearer type id)
- *BFT* (billing failure treatment)
- *BILLING_ENGINE_ID* (BE where account resides)

- *BONUS_TYPE* (name)
- *BUCKET_IDS* (within balance type recharged)
- *BUCKET_LEVEL_COSTS*

EDR tags - C

This list covers all application EDRs defined within this guide, starting with the letter C.

- *CA* (called address)
- *CAET* (call attempt elapsed time)
- *CALLINGNUM* (lcr set calling number)
- *CALLINGNOA* (noa of callingnum)
- *CARD_DESIGN* (voucher details)
- *CARRIERNAME* (carrier name)
- *CARRIERPOS* (position of carrier name in hunt list)
- *CASCADE* (always empty for pi)
- *CASCADE_ID* (balance type cascade IDs)
- *CASCADE_ID* (balance type cascade IDs) - mid call rate change
- *CBAT* (connected by attempt termination)
- *CBTD_BALANCE_TYPES* (list to apply to discounts)
- *CBTD_BALANCE_TYPES* (list to apply to discounts) - mid call rate changes
- *CBTD_BALANCES* (value for each cross balance type)
- *CBTD_BALANCES* (value for each cross balance type) - mid call rate change
- *CBTD_CASCADE_ID* (used for this call)
- *CBTD_CASCADE_ID* (used for this call) - mid call rate change
- *CBTD_COSTS* (costs applied to each cross balance type)
- *CBTD_COSTS* (costs applied to each cross balance type) - mid call rate changes
- *CBTD_COSTS_RND_REM* (rounding remainder of cross balance *CBTD_COSTS*)
- *CBTD_DISCOUNTS* (discounts applied to balance types)
- *CBTD_DISCOUNTS* (discounts applied to balance types) - mid call rate changes
- *CC* (carrier code)
- *CCET* (call connect elapsed time)
- *CCTS* (call connect timestamp)
- *CDR_TYPE* (reason for record generation)
- *CDR_TYPE* (sca reason for record generation)
- *CELLID* (cell id in the idp)
- *CGN* (calling network number)
- *CGNA* (global calling network address)
- *CGNN* (calling party nature of number)

- *CHARGE_EXPIRY* (*new periodic charge expiry*) (new periodic charge expiry)
- *CHARGE_NAME* (of periodic charge)
- *CID* (slee call ID)
- *CLI* (calling logical number)
- *CLI* (for the account that will be changed)
- *CLI* (initiating call number)
- *CLI* (initiating call number) - mid call rate changes
- *CLI* (roaming initiating call number)
- *COMPONENT* (from pi command reference)
- *COSTS* (rated calls)
- *COSTS* (rated calls) - mid call rate changes
- *COSTS_RND_REM* (rounding remainder of balance COSTS)
- *CPC* (calling party category)
- *CPN* (control plan name)
- *CPNI* (calling private network ID)
- *CPNN* (called party nature of number)
- *CPPI* (calling party presentation restricted indicator)
- *CS* (call status, always D)
- *CS* (*call status, S or D*) (call status, S or D)
- *CS* (acs connect status)
- *CT_NAME* (credit transfer)
- *CT_TYPE* (credit transfer)
- *CUG_NAME* (closed user group)
- *CUST* (customer database ID)

EDR tags - D

This list covers all application EDRs defined within this guide, starting with the letter D.

- *DADR* (destination address)
- *DATE* (timestamp sms sent to mmx)
- *DELTS* (timestamp of delivery attempt)
- *DIA_RC* (result code)
- *DIA_REQ* (current session message number)
- *DIA_SID* (session id)
- *DIA_TIME* (time ccr sent)
- *DICWR* (Disable Incoming Calls When Roaming)
- *DIMSI* (destination imsi)
- *DISC* (discount override)

- *DISCOUNT* (always zero for pi)
- *DISCOUNT_TYPE* (applied to this call)
- *DISCOUNT_TYPE* (applied to this call) - R*W
- *DISCOUNT_TYPE* (applied to this call) - service discount
- *DISCOUNTS* (for each named event)
- *DISCOUNTS* (rated calls)
- *DISCOUNTS* (rated calls) - mid call rate changes
- *DISPLAY_SPEND_RATIO* (Balance Type Display to Spend Ratio)
- *DISTRIBUTOR_CHANNEL* (voucher details)
- *DISTS* (timestamp of discard)
- *DLOC* (terminating party location information)
- *DLVR* (message delivered flag)
- *DPATH* (delivery path)
- *DSCA* (destination service center address)
- *DSCGT* (destination gt)
- *DSTL* (destination gt of fda msc)
- *DURATION* (call length)
- *DURATION* (session duration)
- *DURATION_DELTA*

EDR tags - E

This list covers all application EDRs defined within this guide, starting with the letter E.

- *END_CALL_REASON* (reasons for call termination)
- *ESN* (electronic serial number)
- *EVENT_CLASS* (list of classes used)
- *EVENT_COST* (for each named event)
- *EVENT_COUNT* (for each named event)
- *EVENT_NAME* (list used for this call)
- *EVENT_TIME_COST* (for a named event)
- *EXPIRED_WALLET* (ID of expired wallet)
- *EXT(0-9)* (extension buffer contents)

EDR tags - F

This list covers all application EDRs defined within this guide, starting with the letter F.

- *FATS* (first announcement timestamp)
- *FCA* (final call address)
- *FREE_TEXT_FIELD_1* (voucher details)

- *FREE_TEXT_FIELD_2* (voucher details)
- *FREE_TEXT_FIELD_3* (voucher details)
- *FROM* (sip message from header)

EDR tags - G

This list covers all application EDRs defined within this guide, starting with the letter G.

- *GPRS* (general packet radio service)

EDR tags - H

This list covers all application EDRs defined within this guide, starting with the letter H.

- *HOST* (initiating credit transfer)
- *HTS* (hunting timestamp)

EDR tags - I

This list covers all application EDRs defined within this guide, starting with the letter I.

- *IGNORE_BARRED* (ignore numbers in call barring list)
- *IPRI* (incoming protocol value)
- *IPRN* (incoming protocol name)
- *ITS* (incoming tele service)

EDR tags - L

This list covers all application EDRs defined within this guide, starting with the letter L.

- *LAC* (last account code used)
- *LAST_RECORD_DATE*
- *LENGTHS* (rate durations)
- *LENGTHS* (rate durations) - mid call rate changes
- *LGID* (language ID)
- *LI_LOC_NUM* (location information for loc_num)
- *LOC_NUM* (location number in idp)
- *LOCADD* (additional configuration prefixes)
- *LPN* (most recent pin entered)

EDR tags - M

This list covers all application EDRs defined within this guide, starting with the letter M.

- *MAX_CHARGE* (for this call)
- *MAX_CHARGE* (for this call) - mid call rate changes
- *MAX_CONCURRENT* (maximum concurrent accesses allowed)

- *MCOR* (maximum charge override)
- *METHOD* (sip method of request)
- *MFILE* (for rating data)
- *MID_SESSION* (partial EDR)
- *MSCA* (smsc address)
- *MSGD* (message destination)
- *MSGR* (message reference number)
- *MSISDN* (account calling number)
- *MTYP* (message type)

EDR tags - N

This list covers all application EDRs defined within this guide, starting with the letter N.

- *NACK* (freeform recharge list)
- *NACK* (long list of codes)
- *NACK* (short list of codes)
- *NEW_ACCOUNT* (ID of account type)
- *NEW_ACCT_EXPIRY* (date after account deleted)
- *NEW_ACCT_EXPIRY* (date after account deleted)
If the expiry date is updated then this tag will be present.
- *NEW_ACCT_EXPIRY* (date after recharge)
- *NEW_ACCT_EXPIRY* (date after update)
- *NEW_ACCT_STATE* (after update)
- *NEW_ACCT_STATE* (always active - A)
- *NEW_ACCT_STATE* (always frozen - F)
- *NEW_ACCT_STATE* (always preuse - P)
- *NEW_ACCT_STATE* (always terminated - T)
- *NEW_ACCT_TYPE* (ID of account after recharge)
- *NEW_ACCT_TYPE* (prod type swap)
- *NEW_ACTIVE_SVC* (account type)
- *NEW_BALANCE_EXPIRIES* (date after balance update)
- *NEW_BALANCE_EXPIRIES* (dates after voucher recharge)
- *NEW_BARRED_LIST* (of call barring numbers)
- *NEW_CHARGE_STATE* (periodic charge subscription state)
- *NEW_FD* (friends destination number)
- *NEW_FF* (list of friends and family numbers)
- *NEW_LAST_USE* (date last used)
- *NEW_WLC_PERIOD* (after update)

- *NEW_WLC_PLAN* (Id)
- *NOAT* (number of attempt terminations)
- *NRQ* (status report requested for message)
- *NRQD* (emi with defined nrq)
- *NT* (network type)
- *NUMBER* (voucher number)

EDR tags - O

This list covers all application EDRs defined within this guide, starting with the letter O.

- *OA* (sccp originating address)
 - *OADR* (originating address)
 - *OAID* (originating adapter id)
 - *OCAU* (acs cause value)
 - *OCPI* (original called party)
 - *OGEO_ID* (originating geo node id)
 - *OIMSI* (originating imsi)
 - *OIPA* (originating ip address)
 - *OLD_ACCOUNT* (ID of account type)
 - *OLD_ACCT_EXPIRY* (date before recharge)
 - *OLD_ACCT_EXPIRY* (dates before update)
 - *OLD_ACCT_EXPIRY* (dates before update)
- If the expiry date is updated then this tag will be present.
- *OLD_ACCT_STATE* (always active - A)
 - *OLD_ACCT_STATE* (before update)
 - *OLD_ACCT_STATE* (P or D before update)
 - *OLD_ACCT_STATE* (pre-call)
 - *OLD_ACCT_TYPE* (ID of account before recharge)
 - *OLD_ACCT_TYPE* (prod type swap)
 - *OLD_ACTIVE_SVC* (account type)
 - *OLD_BALANCE_EXPIRIES* (dates before balance update)
 - *OLD_BALANCE_EXPIRIES* (dates before voucher recharge)
 - *OLD_BARRED_LIST* (of call barring numbers)
 - *OLD_CHARGE_EXPIRY* (periodic charge expiry date changes)
 - *OLD_CHARGE_STATE* (periodic charge subscription state)
 - *OLD_FD* (friends destination number)
 - *OLD_FF* (list of friends and family numbers)
 - *OLD_WLC_PERIOD* (before update)

- *OLD_WLC_PLAN* (Id)
- *OLOC* (originating party location information)
- *OPERATOR_RELEASED* (commit/revoke reservation)
- *OPRI* (outgoing priority)
- *OPPN* (output protocol name)
- *OPRT* (originating port number)
- *ORIGTRUNK* (idp location number content)
- *OVERDRAWN_AMOUNT* (take Balance Negative)
- *OTI* (originating transaction ID)
- *OTS* (outgoing tele service)
- *OVERRIDDEN_TARIFF_PLAN* (ID)

EDR tags - P

This list covers all application EDRs defined within this guide, starting with the letter P.

- *PCNA* (calling private network address)
- *PC_TYPE* (periodic charge type)
- *PERR* (protocol specific error)
- *PI* (logon name and IP address)
- *PID* (unix process id)
- *PORTED* (name of porting carrier)
- *PTI* (product type id)
- *PTNA* (private terminating network address)
- *PRES* (terminating adapter response)
- *PRID* (protocol identifier)
- *PROVISIONING_DATE* (voucher details)
- *PRO_RATE* (periodic charge subscription)
- *PURCHASING_ACCT_ID* (purchasing wallet ID)
- *PURCHASING_MSISDN* (purchasing CLI)

EDR tags - R

This list covers all application EDRs defined within this guide, starting with the letter R.

- *RATES* (rated calls)
- *RATES* (rated calls) - mid call rate changes
- *RDPN* (redirecting party id)
- *RDPNN* (normalised redirecting party id)
- *RDRES* (redirection reason)
- *RECIPIENT_ACCT_ID* (receiving wallet ID)

- *RECIPIENT_MSISDN* (receiving CLI)
- *RECORD_DATE* (date edr created)
- *REDEEMING_ACCT_REF* (ID of account)
- *REDEEMING_ACCT_TYPE* (name of account type)
- *REFERENCE* (credit card reference, always cc)
- *REFERENCE* (from pi reference)
- *REFERENCE* (operator freeform)
- *REFERENCE* (voucher freeform)
- *REFERENCE* (web site reference - ws)
- *RELC* (acs release cause)
- *RELC* (inap release cause)
- *RELOAD_BONUS* (promotion name)
- *RELOAD_BONUS_AMOUNT* (amount applied)
- *RELOAD_BONUS_EXPIRY* (date remaining bonus expires)
- *RELOAD_BONUS_LEFT* (bonus amount remaining)
- *REMAINING_CHARGE* (partial Charge)
- *REQUEST_URI* (uri request content)
- *RESL* (submit result)
- *RESULT* (frozen or suspended)
- *RESULT* (general cause)
- *RESULT* (pi failure)
- *RESULT* (voucher redemption, always Success)
- *RESULT* (web - success)
- *RETAIL_CHANNEL* (voucher details)
- *REVERSE_CHARGE* (generated by a reverse charge)
- *REWARD* (ID)
- *REWARD_AMOUNTS* (value of reward)
- *REWARD_TYPES* (balance types getting reward)
- *RNCF* (Reservation Not Charged For)
- *ROAMING_COUNTRY* (name)
- *ROAMING_TYPE* (of call)
- *ROUTEDEST* (routing destination for call)

EDR tags - S

This list covers all application EDRs defined within this guide, starting with the letter S.

- *SC* (service category)
- *SCA* (service center address)

- *SCENARIO* (voucher scenario number)
- *SCP_ID* (where call originated)
- *SCRID* (screening rule ID of the message)
- *SEGN* (message segment number)
- *SEGR* (concatenated message reference)
- *SEGT* (total message segments)
- *SEQUENCE_NUMBER* (call identifier)
- *SESSION_SEQUENCE* (partial EDR)
- *SK* (service key)
- *SN* (service number)
- *SRCL* (source location)
- *SSAD* (ip of originating smsc)
- *SSRID* (*screening sub-rule id*) (screening sub-rule ID of the message)
- *SSTN* (smpp service type)
- *STATE* (of recharge)
- *STRR* (status report request)
- *SUB_STATUS* (subscriber status)
- *SVC_ID* (single tariff rated calls)

EDR tags - T

This list covers all application EDRs defined within this guide, starting with the letter T.

- *TAID* (terminating adapter id)
- *TARIFF_CODE* (name)
- *TCAU* (acs terminate cause value)
- *TCE* (acs time call ended)
- *TCE* (ccs time call ended)
- *TCS* (acs time call started)
- *TCS* (ccs time call started)
- *TERMINAL* (Network ID)
- *TEXT* (voucher details)
- *TFN* (tracked feature node list)
- *TGEO_ID* (terminating geo node id)
- *TGNA* (global terminating network address)
- *THRD* (throttled flag)
- *TIME* (creation timestamp of lcr edr)
- *TIMED_OUT* (reservation confirmation)
- *TIMESTAMP* (creation timestamp of scr edr)

- *TLEN* (length of user data in characters)
- *TN* (acs termination number)
- *TN* (ccs called number)
- *TN* (roaming called number)
- *TNNUM* (lcr terminating number)
- *TNNOA* (noa of terminating number)
- *TO* (sip to header content)
- *TPNI* (terminating private network ID)
- *TPO* (tariff plan override)
- *TYPE* (type of edr)
- *TYPE_DESCRIPTION* (voucher type)

EDR tags - U

This list covers all application EDRs defined within this guide, starting with the letter U.

- *ULEN* (length of user data)
- *USER* (operator logon name)
- *USRD* (user data)

EDR tags - V

This list covers all application EDRs defined within this guide, starting with the letter V.

- *VOUCHER* (ID of redeemed voucher)
- *VOUCHER* (serial number of redeemed voucher - 3.1.5)
- *VOUCHER_BATCH* (for voucher batch)
- *VOUCHER_NUMBER* (redeemed voucher)
- *VOUCHER_TYPE* (name)
- *VP* (validity period)

EDR tags - W

This list covers all application EDRs defined within this guide, starting with the letter W.

- *WALLET_DELETED* (always success - Y)
- *WALLET_TYPE* (ID of wallet changed)
- *WALLET_TYPE* (ID of wallet recharged)
- *WALR* (wallet reference)

2

Billing Engine and SMS EDR Definitions

Overview

Introduction

This chapter explains the final format of all existing types of Event Data Records (EDRs) created by the billing engine and the SMS.

EDRs are generated for billing operations that occur as part of a voice call, SMS management interaction or voucher redemption. A number of processes may produce EDRs, and EDRs may be produced on either the billing engine or the SMP.

EDR records are enriched on the SMS by ccsCDRLoader and various plug-in processes.

The ccsCDRLoader has two responsibilities:

- It populates the ccs_be_cdr table of the SMF database on the SMS with formatted EDR records.
- It moves the inputted EDR files into an output EDR file directory structure.

The plug-in processes may add additional fields to EDR records and may also update various tables on the SMF database. A detailed description of all the plug-in processes is beyond the scope of this document.

CCS EDR Files

Introduction

EDR files will contain multiple EDRs, potentially of different types.

EDR file names

EDR file names have the following format:

name_of_process-BEID-PIDSecondsSinceEpoch-uSeconds

where:

- *name_of_process* is the name of the process that generated the EDR. One of the following:
 1. bewriter - if the EDR was generated on the billing engine
 2. ccsCDRFileGenerator - if the EDR was generated on the SMS
- *BEID* is the ID of the billing engine that generated the EDR. This will be '0' if the EDR was generated on the SMS.

- *PID* is the ID of the process that generated the EDR
- *SecondsSinceEpoch* indicates the time and date
- *uSeconds* is microseconds

Example:

beWriter-21-18730-1091693014-151357

EDR lines

Each EDR file consists of a series of single line, newline terminated (Unix style newline - '\n') EDR records.

EDR formats

Each EDR record consists of pipe-separated fields as follows:

field1|field2|field3|...|fieldN

Each EDR field consists of tag-value pairs using a tag=value format. In the case where there are many values to list, the values will be comma separated. An example of this format follows:

tag1=value1|tag2=value2|tag3=value3a,value3b|...|tagN=valueN

Example:

```
BILLING_ENGINE_ID=21|SCP_ID=366273322|SEQUENCE_NUMBER=487291|CDR_TYPE=1|
RECORD_DATE=20040803142342|ACCT_ID=83|ACCT_REF_ID=83|CLI=441234|ACS_CUST_ID=1|
BALANCE_TYPES=1|BALANCES=1000|COSTS=1|ACCOUNT_TYPE=1|CASCADE_ID=1|RATES=50,25|
LENGTHS=120.00,0.00|DISCOUNTS=0,0|MAX_CHARGE=1|DURATION=60|TN=E441234|TCS=20040803141934|
TCE=20040803142034|CS=S|DISCOUNT_TYPE=S*W*R|WALLET_TYPE=1
```

EDR record content

Each CCS caused EDR record consists of two parts: the "header" tags that exists for all CCS EDR types and additional information that will be different depending on the EDR type. The sequence of all fields in the header and the additional information is not guaranteed.

Non-CCS caused EDR records may have "header" tags, but only as defined in the relevant producing application chapters.

Field formats

Each field in an EDR is in a particular format, summarized in this table.

Format	Description
Boolean	Value of "TRUE" or "FALSE" Example: DICWR=TRUE

Format	Description
Date	<p>A time to the nearest second, in format YYYYMMDDHHmmSS where:</p> <ul style="list-style-type: none"> • YYYY = year (for example, 2004) • MM = month (for example, 04 for March) • DD = day of the month (for example, 09) • HH = hours (for example, 13 for 1pm) • mm = minutes (for example, 32) • SS = seconds (for example, 00) <p>Example: A call answered on 16th May 2004 1 minute and 14 seconds after midnight TCS=20040516000114</p>
Integer	<p>A decimal number. Will never exceed a 32 bit number (11 digits), but is often shorter. Leading zeros will not normally be present.</p> <p>Example: WALLET_TYPE=1</p> <p>In the case where there are multiple values to list, the values will be comma separated.</p> <p>Example: RATES=50,100</p>
String	<p>String of characters. Can be any length. Should not contain the characters = or . May include spaces. When the parameter is a string, the string consists of all the characters after the = sign up to the separator between this parameter and the next.</p> <p>Example: DISCOUNT_TYPE=S*W*R </p>
Float	Float is an integer with digits after a decimal point.
List	List is a comma separated list of string values.

Notes:

- Tags may not necessarily be in a fixed order, as the order of processing may vary from one transaction sequence to another.
- Some fields will not be present if the transaction sequence does not reach the state that produces them.

CCS EDR Types

Introduction

The current CCS EDR types created on the Voucher and Wallet Server or the SMS are listed in this topic.

List of EDR types

Each CCS EDR type is summarized in this table.

Type	EDR No.	Description
REGULAR_CALL	1	<ol style="list-style-type: none"> 1. A national voice call that may include IVR interaction. 2. A roaming voice call - CAMEL originating or Mobile terminating (depends on current software installed – see EDR type 11). 3. A USSD Callback call (depends on current software installed – see EDR type 11). 4. Failed SMSMO Roaming or National Call. 5. Failed SMSMT Roaming or National Call. 6. Failed OSA Reservation Seconds Charging. 7. Reservation Revoke. 8. Reservation Commit.
OPERATOR_UPDATE	2	<ol style="list-style-type: none"> 1. Updating an account using the SMS screens. <ol style="list-style-type: none"> 1. When the account is activated (the account state moves from Pre-Use to Active). 2. A freeform recharge using the PI (negative amounts only). 3. A freeform recharge using the PI (when recharge amount = 0).
EXPIRATION	3	<ol style="list-style-type: none"> 1. An account expires. 1. An account balance expires.
RECHARGE	4	<ol style="list-style-type: none"> 1. Successful or failed voucher recharge using the IVR except where the voucher details entered are invalid. 1. Successful or failed voucher recharge using the SMS screens except where the voucher details entered are invalid. 2. Successful voucher recharge using the PI. 3. Successful voucher recharge using USSD.
EVENT	5	<ol style="list-style-type: none"> 1. Successful or failed FnF FnD Config change. 1. Successful or failed PrePaid Data Content charging. 2. Failed OSA Reservation Named Events charging. 3. Failed PrePaid Data Volume/Duration charging. 4. Failed SMSMO Roaming or National Call. 5. Failed SMSMT Roaming or National Call.
Voice Calls	6	<ol style="list-style-type: none"> 1. Direct Amount Charge
Control Plan Service Invoke	7	
FREEFORM_RECHARGE	8	<ol style="list-style-type: none"> 1. A freeform recharge using the screens. 1. A freeform recharge using the PI (positive amounts only). 2. A credit card recharge using the PI (WS prefix for value in REFERENCE field).

Type	EDR No.	Description
CREDITCARD_ RECHARGE	9	<ol style="list-style-type: none"> 1. A credit card recharge using the screens. 1. A credit card recharge using the PI (CC prefix for value in REFERENCE field).
VOUCHER_ FREEFORM	10	<ol style="list-style-type: none"> 1. A voucher freeform recharge using the screens.
ROAMING	11	<p>This EDR type will only be present if the EDR filter is installed to convert the EDR type from type 1.</p> <ol style="list-style-type: none"> 1. A roaming voice call - CAMEL originating or Mobile terminating. 1. A USSD Callback call.
SHORT_ MESSAGE Named Event	12	<ol style="list-style-type: none"> 1. Successful SMSMO national call. 1. Successful SMSMT national call.
SHORT_ MESSAGE Tariffed	13	<ol style="list-style-type: none"> 1. Successful or failed SMSMO roaming call. 1. Successful or failed SMSMT roaming call.
PREPAID_ DATA	14	<ol style="list-style-type: none"> 1. Successful PrePaid Data Volume/Duration charging.
VOUCHER_ REDEEM	15	<ol style="list-style-type: none"> 1. Successful or failed voucher recharge using the IVR. 1. Successful or failed voucher recharge using the screens. 2. Successful voucher recharge using the PI. 3. Successful voucher recharge using USSD
REWARDS	16	<ol style="list-style-type: none"> 1. Successful or failed reward application resulting from a balance update or expiry.
OSA Reservation Amount	21	<ol style="list-style-type: none"> 1. Successful or failed OSA amount based charging using amount-based reservations.
OSA Direct Amount	23	<ol style="list-style-type: none"> 1. Successful or failed OSA amount based charging using single amount-based debits/credits.
OSA Reservation Seconds	24	<ol style="list-style-type: none"> 1. Successful or failed OSA tariffed based charging using tariffed reservations.
OSA Reservation Named Events	25	<ol style="list-style-type: none"> 1. Successful or failed OSA named event based charging using named event reservations.
OSA Direct Seconds	26	<ol style="list-style-type: none"> 1. Successful or failed OSA tariff based charging using single tariff-based debits/credits.
OSA Direct Named Events	27	<ol style="list-style-type: none"> 1. Successful or failed OSA named event based charging using single named event-based debits/credits.
Friends Number Change	28	<ol style="list-style-type: none"> 1. Successful FnF FnD change using PI.

Type	EDR No.	Description
Disable Incoming Calls when Roaming	29	<ol style="list-style-type: none"> The 'disable incoming calls when roaming' check box is changed using the screens. The 'disable incoming calls when roaming' check box is changed using PI.
Call Barring	30	<ol style="list-style-type: none"> Successful call barring number changes using PI.
PRODUCT_TYPE_SWAP	31	<ol style="list-style-type: none"> The product type changes using the screens (may or may not have an associated cost). The product type changes using the IVR (may or may not have an associated cost).
PRODUCT_TYPE_SWAP_BILLED	32	<ol style="list-style-type: none"> The product type changes using the screens where there is an associated cost involved. The product type changed using the IVR.
BAD_PIN	33	<ol style="list-style-type: none"> Invalid voucher number entered using the screens or using the IVR. Invalid secret code entered using the IVR.
Standard voucher type recharge	47	<ol style="list-style-type: none"> Successful voucher recharge from a control plan. Successful voucher recharge from a periodic charge. Successful voucher recharge from a credit transfer.
Periodic charge	49	Successful or failed recharge and/or charge from a periodic charge.
Periodic charge state change	52	Successful or failed periodic charge state change.
Wallet Migration	54	
Wallet Life Cycle	55	Wallet life cycle plan updates.
Voucher Activity	56	

Note: These EDR types were accurate when the document was written, but additional types may have been created since publication.

EDR Definition

Introduction

Each EDR record contains common header fields and extra information fields that are service specific.

EDR header fields

Each EDR record contains a set of common header fields. Header fields contain generic information that should be available for every call. The standard header fields are listed here:

- *ACCT_ID* (changed wallet ID)
- *ACCT_REF_ID* (changed account ID)

- *BILLING_ENGINE_ID* (BE where account resides)
- *CDR_TYPE* (reason for record generation)
- *RECORD_DATE* (date edr created)
- *SCP_ID* (where call originated)
- *SEQUENCE_NUMBER* (call identifier)

Notes

- The sequence of all fields is not guaranteed.
- If the EDR was generated as a result of a change to the account using the SMS UI then the:
 - *SCP_ID* will be zero.
 - *SEQUENCE_NUMBER* will be zero.
- EDR records associated with each wallet expiry contain the MSISDN and product types of all affected subscribers.

Example: A user may have both a mobile and a data card - each with its own SIM. The mobile and data cards are each represented as subscriber records but they share a single wallet.

If the:

- MSISDN of the mobile card is 01234 and that of the data card is 01235
- Product type of the mobile card is 1 (Prepaid Voice) and the product type of the data card is 2 (Prepaid Data).

then the expiry EDR would contain the following fields:

MSISDN=01234,01235

ACCOUNT_TYPE=1,2

EDR extra information fields

The extra information field varies for each type of EDR record and contains additional information specific to the EDR type.

The extra information fields are detailed in the following chapters, based on the type of service provided where for each service the extra information fields are summarized in a table.

EDR Examples

Most of the EDR definitions have one or more examples of what a raw EDR record looks like.

Due to the ever changing use of EDR contents, these examples will usually pertain to the most current version of the software that produces them.

That means tag content examples will not necessarily be correct of previous versions of software.

EDRs

Introduction

This section explains how EDRs are used in CCS. For more information, see *CCS Technical Guide*.

Diagram

Here is an example showing EDR creation, transfer to the SMS and processing.

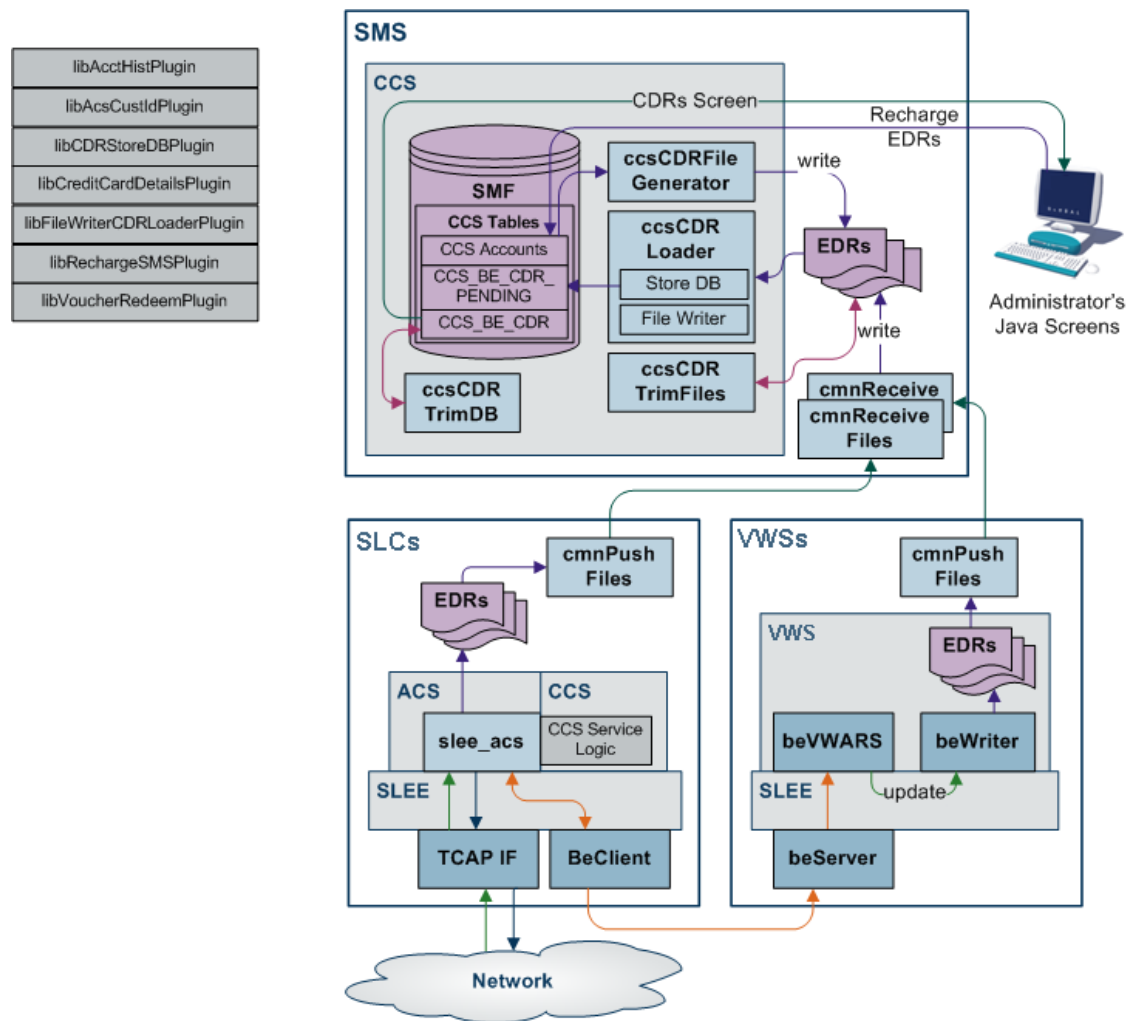

Dataflow

This table shows the process by which EDRs are written and collected to the SMF database.

Stage	Description
1	The SLC is the originator of all events that cause Voucher and Wallet Servers to perform tasks during call processing, as the SLC controls how the service responds to network events. The SLC signals events to the VWS Voucher and Wallet Server using the CCS Billing Engine Protocol. The service sends messages to the Voucher and Wallet Servers through the ccsBeClient interface.
2	EDRs are written out to disk as ASCII files on the VWS.
3	The files are transferred to the SMS.
4	The files are indexed and made available to the Java User Screens and external EDR post-processing tools.
5	CCS screens created EDRs are written by the ccsCDRGenerator process to the same directory the VWS flat files are transferred into. The ccsCDRLoader then loads both the same way.

Stage 2

On the VWS in `/IN/service_packages/eserv.config` the following configuration item tells the `beWriter` which directory to write the finished flat file of EDRs:

```
BE.beWriter.beCdrOutDirectory = "/IN/service_packages/E2BE/logs/CDR"
```

Stage 3

On the VWS in `/IN/service_packages/eserv.config` the following configuration item tells the `cmnPushFiles` process which directory to upload flat file EDRs from to the SMP:

```
BE.cmnPushFiles.CDR
# local BE directory for flat file CDRs
"-d", "/IN/service_packages/E2BE/logs/CDR"
# upload files to this directory on the SMP
"-r", "/IN/service_packages/CCS/logs/CDR-in"
# Send files to this SMP hostname
"-h", "ccssmp"
```

The local directory defined with the `-d` switch must match the path defined in the `BE.beWriter.beCdrOutDirectory` configuration parameter.

Stage 4

On the SMS in `/IN/service_packages/eserv.config` the following configuration item tells the `ccsCDRLoader` process where to get the uploaded flat file EDRs for processing:

```
CCS.ccsCDRLoader.inDir = "/IN/service_packages/CCS/logs/CDR-in"
```

Note: The `inDir` configuration parameter must be the same path as the `-r` switch defined by the `BE.cmnPushFiles.CDR` section on the VWS.

The following configuration item is where the `ccsCDRLoader` will place the original flat file EDRs once all the plug-ins have been run:

```
CCS.ccsCDRLoader.outDir = "/IN/service_packages/CCS/logs/CDR-store"
```

The following configuration section on the SMS tells the `ccsCDRLoader` which plug-ins to run over every record in the flat file EDRs:

```
CCS.ccsCDRLoader.pluginLibs = ["libCDRStoreDBPlugin.so",
"libFileWriterCDRLoaderPlugin.so"]
```

The EDR Store DB plug-in loads the EDR record from the input flat file into the CCS_BE_CDR table. The data for each record may have been modified by other plug-ins, so is usually last in the list. If database loading of EDRs is not required, then this plug-in should not be configured to achieve the required behavior.

Other plug-ins may be available, for example, to place modified EDRs into a separate flat file than the original ones or to update the account history.

Stage 5

The ccsCDRFileGenerator process writes SMS produced EDRs to a directory for the ccsCDRLoader process to read. The following parameter value in **eserv.config** should be a different directory to any the ccsCDRLoader uses, as it stores the partially written files until the finished file will be written:

```
CCS.ccsCDRFileGenerator.TempOutputDirectory = "/IN/service_packages/CCS/logs/CDR-tmp"
```

The following parameter should always be set to the same value of the CCS.ccsCDRLoader.inDir parameter and is where the ccsCDRFileGenerator writes the finished flat file EDRs for SMS activity:

```
CCS.ccsCDRFileGenerator.OutputDirectory = "/IN/service_packages/CCS/logs/CDR-in"
```

The ccsCDRLoader then reads flat file EDRs produced by the VWS and SMS without knowing where they have come from.

Process descriptions

This table describes the processes involved in EDR creation, transfer and processing in CCS.

Process	Role	Further information
beWriter	beWriter writes EDRs on the VWS based on VWS Account, Wallet and Balance transactions.	<i>VWS Technical Guide</i>
cmnPushFiles	cmnPushFiles reads EDRs on the VWS and sends them to a configured directory on the SMS. Once the files have been sent, the read files on the VWS are archived by cmnPushFiles.	cmnPushFiles
cmnReceiveFiles	cmnReceiveFiles accepts EDRs sent from cmnPushFiles and writes them to the directory on the SMS specified by cmnReceiveFiles.	<i>SMS Technical Guide</i>
ccsCDRLoader	ccsCDRLoader scans the input directory written to by cmnReceiveFiles and loads any EDRs into the CCS_BE_CDRS table in the SMF database.	ccsCDRLoader
ccsCDRFileGenerator	ccsCDRFileGenerator creates EDRs recording relevant actions taken in the CCS Java Administration screens. Relevant actions include changes to the balances or wallets.	ccsCDRFileGenerator
ccsCDRTrimDB	ccsCDRTrimDB periodically scans the CCS_BE_CDR table in the SMF and removes records past a specified age.	ccsCDRTrimDB
ccsCDRTrimFiles	ccsCDRTrimFiles periodically scans the EDR archive directory on the SMS and removes files over a specified age.	ccsCDRTrimFiles

Process	Role	Further information
CCS GUI	The CCS GUI enables: <ul style="list-style-type: none"> Subscriber details and Wallets to be updated through EDRs created by ccsCDRGenerator, and EDRs in CCS_BE_CDR to be viewed. 	<i>CCS User's Guide</i>

EDR triggers

The following messages, among others, cause the beWriter to write EDRs:

- Call End Notification
- Wallet Recharge Request
- Named Event

CCS-VWS Protocol overview

The new CCS-VWS protocol is built upon an extensible self-describing message format called Escher. The new protocol is easily extensible, versioned, and allows additions without breaking backward compatibility. The CCS-VWS protocol definition is defined for internal use only.

Controlling the flow of EDRs

There are configuration items in **eserv.config** that link where files are read and written to that allow the flow to happen. The out directory of an earlier stage must match the in directory path for the system to function. The defaults at install time are set to work without further modification.

Checking the values in **eserv.config**

The current value of a configuration item in **eserv.config** can be checked by using the Configuration Read tool. To use this tool use the following command:

```
/IN/service_packages/SMS/bin/cmnConfigRead config_item
```

Example:

```
/IN/service_packages/SMS/bin/cmnConfigRead  
BE.beWriter.beCdrOutDirectory
```

```
gives: /IN/service_packages/E2BE/logs/CDR
```

Checking the validity of **eserv.config**

The validity of an **eserv.config** file can be checked using:

```
/IN/service_packages/SMS/bin/cmnConfigSyntaxCheck -v  
/IN/service_packages/
```

eserv.config

Result:

Syntax check passed for file
/IN/service_packages/

eserv.config

3

Operator Updates

Overview

Introduction

This chapter defines the CCS EDRs for operator updates.

Account Creation using Screens (EDR 2)

Mandatory EDR 2 fields

This list identifies the mandatory EDR record fields for account creation using screens (CDR type 2):

- *ACCOUNT_TYPE* (Product Type ID)
- *ACS_CUST_ID* (ACS Customer ID)
- *BALANCE_TYPES* (account changed or created)
- *BALANCES* (pre-call or account creation)
- *COSTS* (rated calls)
- *MAX_CONCURRENT* (maximum concurrent accesses allowed)
- *MSISDN* (account calling number)
- *NEW_ACCT_STATE* (always preuse - P)
- *TERMINAL* (Network ID)
- *USER* (operator logon name)

Optional EDR 2 fields

This list identifies the optional EDR record fields for account creation using screens (CDR type 2):

- *ACTIVATION_DATE* (account activation date)
- *NEW_ACCT_EXPIRY* (date after update)

Example EDR 2

```
BILLING_ENGINE_ID=21|SCP_ID=110537566|SEQUENCE_NUMBER=139450184|CDR_TYPE=2|
RECORD_DATE=20040803121758|ACCT_ID=20054|ACCT_REF_ID=0|BALANCE_TYPES=1,2,5|
BALANCES=0,0,0|COSTS=2000,0,0|ACTIVATION_DATE=0|NEW_ACCT_EXPIRY=0|MAX_CONCURRENT=1|
NEW_ACCT_STATE=P|ACS_CUST_ID=1|TERMINAL=192.168.25.108|USER=SU|ACCOUNT_TYPE=1|
MSISDN=1394111111
```

Note

The sequence of all fields output in an EDR is not guaranteed.

Account Creation using PI (EDR 2)

Mandatory EDR 2 fields

This list identifies the mandatory EDR record fields for account creation using PI (CDR type 2):

- *ACCOUNT_TYPE* (Product Type ID)
- *ACS_CUST_ID* (ACS Customer ID)
- *BALANCE_TYPES* (account changed or created)
- *BALANCES* (pre-call or account creation)
- *COSTS* (rated calls)
- *MAX_CONCURRENT* (maximum concurrent accesses allowed)
- *MSISDN* (account calling number)
- *NEW_ACCT_STATE* (always preuse - P)
- *PI* (logon name and IP address)
- *WALLET_TYPE* (ID of wallet recharged)

Optional EDR 2 fields

This list identifies the optional EDR record fields for account creation using PI (CDR type 2):

- *ACTIVATION_DATE* (account activation date)
- *NEW_ACCT_EXPIRY* (date after update)

Example EDR 2

```
BILLING_ENGINE_ID=21|SCP_ID=110537566|SEQUENCE_NUMBER=139450184|CDR_TYPE=2|  
RECORD_DATE=20070703121758|ACCT_ID=20054|ACCT_REF_ID=0|ACCOUNT_TYPE=11|  
BALANCE_TYPES=1,2,5|BALANCES=0,0,0|COSTS=2000,0,0|ACTIVATION_DATE=0|NEW_ACCT_EXPIRY=0|  
MAX_CONCURRENT=1|NEW_ACCT_STATE=P|ACS_CUST_ID=1|MSISDN=0139477777|WALLET_TYPE=1|PI=  
adminAT192.168.25.106
```

Note

The sequence of all fields output in an EDR is not guaranteed.

Account Balance Changes using Screens (EDR 2)

Mandatory EDR 2 fields

This list identifies the mandatory EDR record fields for account balance changes using screens (CDR type 2):

- *ACCOUNT_TYPE* (Product Type ID)
- *ACS_CUST_ID* (ACS Customer ID)
- *BALANCE_TYPES* (existing account)
- *BALANCES* (pre-transaction account balances)
- *COSTS* (rated calls)
- *MSISDN* (account calling number)

When the ccsCDRLoader plugin is installed on the SMS, this tag will be present.

- *NEW_BALANCE_EXPIRIES* (date after balance update)
- *OLD_BALANCE_EXPIRIES* (dates before balance update)
- *TERMINAL* (Network ID)
- *USER* (operator logon name)
- *WALLET_TYPE* (ID of wallet changed)

Optional EDR 2 fields

This list identifies the optional EDR record fields for account balance changes using screens (CDR type 2):

- *NEW_ACCT_STATE* (after update)
- *OLD_ACCT_STATE* (before update)
- *REASON* (change reason)

Example EDR 2

```
BILLING_ENGINE_ID=21|SCP_ID=110537566|SEQUENCE_NUMBER=139450184|CDR_TYPE=2|
RECORD_DATE=20040803122430|ACCT_ID=83|ACCT_REF_ID=83|USER=SU|TERMINAL=123.123.123|
ACCOUNT_TYPE=1|BALANCE_TYPES=1|BALANCES=2000|COSTS=-1000|OLD_BALANCE_EXPIRIES=|
NEW_BALANCE_EXPIRIES=0|ACS_CUST_ID=1|WALLET_TYPE=1|MSISDN=1394111111|REASON="Balance
topped up"
```

Note

The sequence of all fields output in an EDR is not guaranteed.

Account Balance Changes using PI (EDR 2)

Mandatory EDR 2 fields

This list identifies the mandatory EDR record fields for account balance changes using PI (CDR type 2):

- *ACCOUNT_TYPE* (Product Type ID)
- *ACS_CUST_ID* (ACS Customer ID)
- *BALANCE_TYPES* (existing account)
- *BALANCES* (pre-transaction account balances)
- *COSTS* (rated calls)

- *MSISDN* (account calling number)
When the ccsCDRLoader plugin is installed on the SMS, this tag will be present.
- *NEW_ACCT_EXPIRY* (date after update)
- *NEW_BALANCE_EXPIRIES* (date after balance update)
- *OLD_ACCT_EXPIRY* (dates before update)
- *OLD_BALANCE_EXPIRIES* (dates before balance update)
- *PI* (logon name and IP address)
- *WALLET_TYPE* (ID of wallet changed)

Optional EDR 2 fields

This list identifies the optional EDR record fields for account balance changes using PI (CDR type 2):

- *NEW_ACCT_STATE* (after update)
- *OLD_ACCT_STATE* (before update)

Example EDR 2

```
BILLING_ENGINE_ID=4|SCP_ID=161986004|SEQUENCE_NUMBER=9|CDR_TYPE=2|
RECORD_DATE=20070809121732|ACCT_ID=1021|ACCT_REF_ID=1021|PI=adminAT192.168.25.108|
WALLET_TYPE=1|ACCOUNT_TYPE=41|OLD_ACCT_EXPIRY=20080901185959|
NEW_ACCT_EXPIRY=20080901185959|BALANCE_TYPES=1|BALANCES=124495|COSTS=3322|
OLD_BALANCE_EXPIRIES=20080131190018|NEW_BALANCE_EXPIRIES=20080131190018|ACS_CUST_ID=1|
MSISDN=11012
```

Note

The sequence of all fields output in an EDR is not guaranteed.

Account State Update using Screens (EDR 2)

Mandatory EDR 2 fields

This list identifies the mandatory EDR record fields for account state update using screens (EDR type 2):

- *ACCOUNT_TYPE* (Product Type ID)
- *ACS_CUST_ID* (ACS Customer ID)
- *BALANCE_TYPES* (existing account)
- *BALANCES* (pre-transaction account balances)
- *COSTS* (rated calls)
- *MSISDN* (account calling number)
When the ccsCDRLoader plugin is installed on the SMS, this tag will be present.
- *NEW_ACCT_EXPIRY* (date after update)
- *NEW_BALANCE_EXPIRIES* (date after balance update)

- *OLD_BALANCE_EXPIRIES* (dates before balance update)
- *TERMINAL* (Network ID)
- *USER* (operator logon name)

Optional EDR 2 fields

This table lists the optional fields for account state update using screens (EDR type 2):

- *ACTIVATION_DATE* (account activation date)
- *MAX_CONCURRENT* (maximum concurrent accesses allowed)
- *NEW_ACCT_STATE* (after update)
- *NEW_LAST_USE* (date last used)
- *OLD_ACCT_EXPIRY* (dates before update)
- *OLD_ACCT_STATE* (before update)
- *REASON* (change reason)

Example EDR 2

```
BILLING_ENGINE_ID=21|SCP_ID=110537566|SEQUENCE_NUMBER=139450184|CDR_TYPE=2|
RECORD_DATE=20040803122626|ACCT_ID=83|ACCT_REF_ID=83|USER=SU|TERMINAL=192.168.25.108|
ACCOUNT_TYPE=1|OLD_ACCT_STATE=P|NEW_ACCT_STATE=A|BALANCE_TYPES=1|BALANCES=3000|COSTS=0|
OLD_BALANCE_EXPIRIES=|NEW_BALANCE_EXPIRIES=0|ACS_CUST_ID=1|MSISDN=1394111111|
REASON="Activate wallet"
```

Note

The sequence of all fields output in an EDR is not guaranteed.

Account State Update using PI (EDR 2)

Mandatory EDR 2 fields

This list identifies the mandatory EDR record fields for account state update using PI (EDR type 2):

- *ACCOUNT_TYPE* (Product Type ID)
- *ACS_CUST_ID* (ACS Customer ID)
- *BALANCE_TYPES* (existing account)
- *BALANCES* (pre-transaction account balances)
- *COSTS* (rated calls)
- *MSISDN* (account calling number)

When the ccsCDRLoader plugin is installed on the SMS, this tag will be present.

- *NEW_ACCT_EXPIRY* (date after update)
- *NEW_ACCT_STATE* (after update)
- *NEW_BALANCE_EXPIRIES* (date after balance update)

- *OLD_ACCT_EXPIRY* (dates before update)
- *OLD_ACCT_STATE* (before update)
- *OLD_BALANCE_EXPIRIES* (dates before balance update)
- *PI* (logon name and IP address)
- *WALLET_TYPE* (ID of wallet recharged)

Optional EDR 2 fields

This list identifies the optional EDR record fields for account state update using PI (EDR type 2):

- *ACTIVATION_DATE* (account activation date)
- *MAX_CONCURRENT* (maximum concurrent accesses allowed)
- *NEW_LAST_USE* (date last used)

Example EDR 2

```
BILLING_ENGINE_ID=21|SCP_ID=161986004|SEQUENCE_NUMBER=139450184|CDR_TYPE=2|
RECORD_DATE=20070719085005|ACCT_ID=83|ACCT_REF_ID=83|ACCOUNT_TYPE=24|
PI=adminAT192.168.25.106|OLD_ACCT_STATE=F|NEW_ACCT_STATE=A|OLD_ACCT_EXPIRY=0|
NEW_ACCT_EXPIRY=0|BALANCE_TYPES=1|BALANCES=3000|COSTS=0|OLD_BALANCE_EXPIRIES=0|
NEW_BALANCE_EXPIRIES=0|ACS_CUST_ID=1|WALLET_TYPE=1|MSISDN=01892111111
```

Note

The sequence of all fields output in an EDR is not guaranteed.

Account Expiry Update using Screens (EDR 2)

Mandatory EDR 2 fields

This list identifies the mandatory EDR record fields for account expiry update using screens (EDR type 2):

- *ACCOUNT_TYPE* (Product Type ID)
- *ACS_CUST_ID* (ACS Customer ID)
- *BALANCE_TYPES* (existing account)
- *BALANCES* (pre-transaction account balances)
- *COSTS* (rated calls)
- *MSISDN* (account calling number)

When the ccsCDRLoader plugin is installed on the SMS, this tag will be present.

- *NEW_ACCT_EXPIRY* (date after update)
- *NEW_BALANCE_EXPIRIES* (date after balance update)
- *OLD_ACCT_EXPIRY* (dates before update)
- *OLD_ACCT_STATE* (before update)
- *OLD_BALANCE_EXPIRIES* (dates before balance update)

- *TERMINAL* (Network ID)
- *USER* (operator logon name)
- *WALLET_DELETED* (always success - Y)
- *WALLET_TYPE* (ID of wallet recharged)

Optional EDR 2 fields

This list identifies the optional EDR record fields for account state expiry using screens (EDR type 2):

- *ACTIVATION_DATE* (account activation date)
- *MAX_CONCURRENT* (maximum concurrent accesses allowed)
- *OLD_ACCT_STATE* (before update)
- *NEW_ACCT_STATE* (after update)
- *REASON* (change reason)

Example EDR 2

```
BILLING_ENGINE_ID=21|SCP_ID=110537566|SEQUENCE_NUMBER=13954|CDR_TYPE=2|
RECORD_DATE=20040803123349|ACCT_ID=83|ACCT_REF_ID=83|USER=SU|TERMINAL=192.168.25.108|
ACCOUNT_TYPE=1|OLD_ACCT_EXPIRY=20140103120000|NEW_ACCT_EXPIRY=20170103120000|
BALANCE_TYPES=1|BALANCES=3000|COSTS=0|WALLET_DELETED=N|OLD_ACCT_STATE=A|
OLD_BALANCE_EXPIRIES=|NEW_BALANCE_EXPIRIES=0|ACS_CUST_ID=1|WALLET_TYPE=1|
MSISDN=1394111111|REASON="Extend account expiry date"
```

Note

The sequence of all fields output in an EDR is not guaranteed.

Balance Expiry Update using Screens (EDR 2)

Mandatory EDR 2 fields

This list identifies the mandatory EDR record fields for balance expiry update using screens (EDR type 2):

- *ACCOUNT_TYPE* (Product Type ID)
- *ACS_CUST_ID* (ACS Customer ID)
- *BALANCE_TYPES* (existing account)
- *BALANCES* (pre-transaction account balances)
- *COSTS* (rated calls)
- *MSISDN* (account calling number)

When the ccsCDRLoader plugin is installed on the SMS, this tag will be present.

- *NEW_BALANCE_EXPIRIES* (date after balance update)
- *OLD_BALANCE_EXPIRIES* (dates before balance update)
- *TERMINAL* (Network ID)

- *USER* (operator logon name)

Optional EDR 2 fields

This list identifies the optional EDR record fields for balance expiry update using screens (CDR type 2):

- *NEW_ACCT_STATE* (after update)
- *OLD_ACCT_STATE* (before update)
- *REASON* (change reason)

Example EDR 2

```
BILLING_ENGINE_ID=21|SCP_ID=110537566|SEQUENCE_NUMBER=139540184|CDR_TYPE=2|
RECORD_DATE=20040803123655|ACCT_ID=83|ACCT_REF_ID=83|USER=SU|ACCOUNT_TYPE=1|
BALANCE_TYPES=1,2|BALANCES=1000,3500|COSTS=0,0|
OLD_BALANCE_EXPIRIES=20040903122900,20040805122900|
NEW_BALANCE_EXPIRIES=20040910122900,20040812122900|ACS_CUST_ID=1|MSISDN=1394111111
```

Note

The sequence of all fields output in an EDR is not guaranteed.

Account Deleted using Screens (EDR 2)

Mandatory EDR 2 fields

This list identifies the mandatory EDR record fields for account deleted using screens (EDR type 2):

- *ACCOUNT_TYPE* (Product Type ID)
 - *ACTIVATION_DATE* (account activation date)
 - *BALANCE_TYPES* (existing account)
 - *BALANCES* (pre-transaction account balances)
 - *COSTS* (rated calls)
 - *MAX_CONCURRENT* (maximum concurrent accesses allowed)
 - *MSISDN* (account calling number)
- When the ccsCDRLoader plugin is installed on the SMS, this tag will be present.
- *NEW_ACCT_EXPIRY* (date after update)
 - *NEW_BALANCE_EXPIRIES* (date after balance update)
 - *OLD_ACCT_EXPIRY* (dates before update)
 - *OLD_BALANCE_EXPIRIES* (dates before balance update)
 - *TERMINAL* (Network ID)
 - *USER* (operator logon name)
 - *WALLET_DELETED* (always success - Y)

Optional EDR 2 fields

This list identifies the optional EDR record fields for account deleted using screens (CDR type 2):

- *NEW_ACCT_STATE* (after update)
- *OLD_ACCT_STATE* (before update)
- *REASON* (change reason)

Example EDR 2

```
BILLING_ENGINE_ID=21|SCP_ID=175677458|SEQUENCE_NUMBER=139540184|CDR_TYPE=2|
RECORD_DATE=20070716112330|ACCT_ID=20056|ACCT_REF_ID=20056|USER=SU|
TERMINAL=192.168.25.108|BALANCE_TYPES=1,2,3,4,5|BALANCES=10000,0,0,0,0|
COSTS=10000,0,0,0,0|WALLET_DELETED=Y|ACTIVATION_DATE=20040703122900|NEW_ACCT_EXPIRY=0|
MAX_CONCURRENT=1|OLD_ACCT_STATE=P|ACCOUNT_TYPE=1|NEW_BALANCE_EXPIRIES=0|
OLD_BALANCE_EXPIRIES=20040811100354|OLD_ACCT_EXPIRY=20040811100357|MSISDN=1394111111
```

Note

The sequence of all fields output in an EDR is not guaranteed.

Account Activated by System (EDR 2)

Mandatory EDR 2 fields

The account will be activated by the system when a call is made on an account that is in a 'PreUse' state.

This list identifies the mandatory EDR record fields for an account activated by the system (EDR type 2):

- *ACCOUNT_TYPE* (Product Type ID)
- *ACS_CUST_ID* (ACS Customer ID)
- *BALANCE_TYPES* (existing account)
- *BALANCES* (pre-transaction account balances)
- *COSTS* (rated calls)
- *MSISDN* (account calling number)

When the ccsCDRLoader plugin is installed on the SMS, this tag will be present.
- *NEW_ACCT_EXPIRY* (date after account deleted)

If the expiry date is updated then this tag will be present.
- *NEW_ACCT_STATE* (always active - A)
- *NEW_BALANCE_EXPIRIES* (date after balance update)
- *OLD_ACCT_EXPIRY* (dates before update)

If the expiry date is updated then this tag will be present.
- *OLD_ACCT_STATE* (P or D before update)

- `OLD_BALANCE_EXPIRIES` (dates before balance update)

Example EDR 2

```
BILLING_ENGINE_ID=21|SCP_ID=110537566|SEQUENCE_NUMBER=139450184|CDR_TYPE=2|  
RECORD_DATE=20040806100354|ACCT_ID=20064|ACCT_REF_ID=20026|BALANCE_TYPES=1|  
NEW_ACCT_STATE=A|OLD_ACCT_STATE=P|ACS_CUST_ID=1|ACCOUNT_TYPE=1|MSISDN=1394111111
```

Note

The sequence of all fields output in an EDR is not guaranteed.

4

Voucher Activity

Overview

In this chapter

This chapter contains the following topics.
[Voucher Activity using Screen or PI \(EDR 56\)](#) 2

Voucher Activity using Screen or PI (EDR 56)

Mandatory EDR 56 fields

This list identifies the mandatory EDR record fields for a voucher activity using screens or PI (EDR type 56):

- *ACCT_ID* (changed wallet ID)
- *ACCT_REF_ID* (changed account ID)
- *ACS_CUST_ID* (ACS Customer ID)
- *ACTION* (voucher action)
- *ACTION_DETAIL* (voucher action)
- *USER* (operator logon name)
- *NUMBER* (voucher number)

MSISDN additional fields

If the MSISDN ccsCDRLoader plug-in is installed on the SMS, the following field will be present:

- *MSISDN* (account calling number)

Example EDR 56

```
BILLING_ENGINE_ID=0|SCP_ID=0|SEQUENCE_NUMBER=463|CDR_TYPE=56|RECORD_DATE=20180328102552|
ACCT_ID=0|ACCT_REF_ID=0|ACS_CUST_ID=21|ACTION=VRC|ACTION_DETAIL=Success|USER=SU|
NUMBER=60041
```

Note

The sequence of all fields output in an EDR is not guaranteed.

5

Voucher Recharges

Overview

Introduction

This chapter defines the CCS EDRs for voucher recharges.

Voucher Recharge Succeeds using Screens (EDR 4,15)

Introduction

Two or three EDRs are created for this event:

- A type 4
- A type 15
- A type 16 when the Rewards plug-in is being used. See Rewards chapter for the EDR definition.

Mandatory EDR 4 fields

This list identifies the mandatory EDR record fields for voucher recharge succeeds using screens (EDR type 4):

- *ACCOUNT_TYPE* (Product Type ID)
- *ACS_CUST_ID* (ACS Customer ID)
- *BALANCE_TYPES* (existing account)
- *BALANCES* (pre-transaction account balances)
- *BATCH_DESCRIPTION* (for voucher batch)
- *COSTS* (rated calls)
- *CS* (*call status, S or D*) (call status, S or D)
- *NEW_ACCT_EXPIRY* (date after update)
- *NEW_BALANCE_EXPIRIES* (dates after voucher recharge)
- *OLD_ACCT_EXPIRY* (dates before update)
- *OLD_BALANCE_EXPIRIES* (dates before voucher recharge)
- *TERMINAL* (Network ID)
- *TYPE_DESCRIPTION* (voucher type)
- *USER* (operator logon name)

Optional EDR 4 fields

If they are not present, the ccsCDRLoader voucher plug-in does not process the EDR. For more information about ccsCDRLoader, see Process descriptions.

This list identifies the optional EDR record fields for voucher recharge succeeds using screens (EDR type 4):

- *REFERENCE* (voucher freeform)
- *VOUCHER* - one of:
 - *VOUCHER* (ID of redeemed voucher)
 - *VOUCHER* (serial number of redeemed voucher - 3.1.5)

Mandatory EDR 15 fields

This list identifies the mandatory EDR record fields for voucher recharge succeeds using screens (EDR type 15):

- *ACCOUNT_TYPE* (Product Type ID)
- *ACS_CUST_ID* (ACS Customer ID)
- *BALANCE_EXPIRIES* (period hours)
- *BALANCE_TYPES* (existing account)
- *COSTS* (rated calls)
- *REDEEMING_ACCT_REF* (ID of account)
- *RESULT* (voucher redemption, always Success)
- *VOUCHER* - one of:
 - *VOUCHER* (ID of redeemed voucher)
 - *VOUCHER* (serial number of redeemed voucher - 3.1.5)

Optional EDR 15 fields

This list identifies the optional EDR record fields for voucher recharge succeeds using screens (EDR type 15):

- *BATCH_DESCRIPTION* (for voucher batch)
- *NEW_ACCOUNT* (ID of account type)
- *OLD_ACCOUNT* (ID of account type)
- *REDEEMING_ACCT_TYPE* (name of account type)
- *SCENARIO* (voucher scenario number)
- *TYPE_DESCRIPTION* (voucher type)
- *REDEEMING_SUBSCRIBER_ID* (subscriber ID)

Account Activated additional fields

If the account is activated, the following fields are generated:

- *NEW_ACCT_STATE* (always active - A)
- *OLD_ACCT_STATE* (P or D before update)

Reload Bonus additional fields

If the account has a promotional reload bonus configured, the following fields are generated (EDR types 4, 15 and 16):

- *RELOAD_BONUS* (promotion name)
- *RELOAD_BONUS_AMOUNT* (amount applied)
- *RELOAD_BONUS_EXPIRY* (date remaining bonus expires)
- *RELOAD_BONUS_LEFT* (bonus amount remaining)

MSISDN additional fields

If the MSISDN ccsCDRLoader plug-in is installed on the SMS, the following field will be present:

- *MSISDN* (account calling number)

Example EDR 4

```
BILLING_ENGINE_ID=21|SCP_ID=110537566|SEQUENCE_NUMBER=139450184|CDR_TYPE=4|
RECORD_DATE=20040803152956|ACCT_ID=61|ACCT_REF_ID=61|ACS_CUST_ID=1|
VOUCHER=7609766|VOUCHER_NUMBER=0000000067|CS=S|USER=SU|ACCOUNT_TYPE=1|
BALANCE_TYPES=1|BALANCES=1001800|COSTS=-1000|NEW_BALANCE_EXPIRIES=|
OLD_BALANCE_EXPIRIES=0
```

Example EDR 15

```
BILLING_ENGINE_ID=21|SCP_ID=110537566|SEQUENCE_NUMBER=139450184|CDR_TYPE=15|
RECORD_DATE=20070719111321|ACCT_ID=61|ACCT_REF_ID=61|ACS_CUST_ID=1|REDEEMING_ACCT_REF=61|
VOUCHER=7608766|VOUCHER_NUMBER=0000000067|RESULT=Success|BALANCE_TYPES=1|COSTS=-1000|
BALANCE_EXPIRIES=|ACCOUNT_TYPE=24
```

If the **useVoucherRedeemCDR** parameter in the ccsCDRLoader section of eserv.config in SMS is set as true, then additional voucher related fields are also returned as shown in the below example:

```
BILLING_ENGINE_ID=42|SCP_ID=55771394|SEQUENCE_NUMBER=0|CDR_TYPE=15|
RECORD_DATE=20180328121357|ACCT_ID=3|ACCT_REF_ID=4|ACS_CUST_ID=21|REDEEMING_ACCT_REF=4|
REDEEMING_ACCT_TYPE=21|RESULT=Success|VOUCHER=184|VOUCHER_NUMBER=60045|BALANCE_TYPES=78|
COSTS=-10|BALANCE_EXPIRIES=|USER=SU|TERMINAL=10.191.235.82|WALLET_TYPE=5|BARCODE=12|
TEXT=adding|CARD_DESIGN=90|DISTRIBUTOR_CHANNEL=fields|RETAIL_CHANNEL=for a|
FREE_TEXT_FIELD_1=CDR|FREE_TEXT_FIELD_2=test|FREE_TEXT_FIELD_3=case|
PROVISIONING_DATE=20180313091814
```

Note

The sequence of all fields output in an EDR is not guaranteed.

Voucher Recharge Succeeds using IVR (EDR 4,15)

Introduction

Two or three EDRs are created for this event:

- A type 4
- A type 15
- A type 16 when the Rewards plug-in is being used. See Rewards chapter for the EDR definition.

Mandatory EDR 4 fields

This list identifies the mandatory EDR record fields for voucher recharge succeeds using IVR (EDR type 4):

- *ACCOUNT_TYPE* (Product Type ID)
- *ACS_CUST_ID* (ACS Customer ID)
- *BALANCE_TYPES* (existing account)
- *BALANCES* (pre-transaction account balances)
- *BATCH_DESCRIPTION* (for voucher batch)
- *COSTS* (rated calls)
- *CS* (call status, S or D) (call status, S or D)
- *NEW_BALANCE_EXPIRIES* (dates after voucher recharge)
- *OLD_BALANCE_EXPIRIES* (dates before voucher recharge)
- *TYPE_DESCRIPTION* (voucher type)
- *WALLET_TYPE* (ID of wallet changed)

Optional EDR 4 fields

If they are not present, the ccsCDRLoader voucher plug-in does not process the EDR. For more information about ccsCDRLoader, see Process descriptions.

This list identifies the optional EDR record fields for voucher recharge succeeds using IVR (EDR type 4):

- *REFERENCE* (voucher freeform)
- *VOUCHER* - one of:
 - *VOUCHER* (ID of redeemed voucher)
 - *VOUCHER* (serial number of redeemed voucher - 3.1.5)

Mandatory EDR 15 fields

This list identifies the mandatory EDR record fields for voucher recharge succeeds using IVR (EDR type 15):

- *ACS_CUST_ID* (ACS Customer ID)
- *BALANCE_EXPIRIES* (period hours)
- *BALANCE_TYPES* (existing account)
- *COSTS* (rated calls)
- *REDEEMING_ACCT_REF* (ID of account)
- *RESULT* (voucher redemption, always Success)
- *VOUCHER* - one of:
 - *VOUCHER* (ID of redeemed voucher)
 - *VOUCHER* (serial number of redeemed voucher - 3.1.5)

Optional EDR 15 fields

This list identifies the optional EDR record fields for voucher recharge succeeds using IVR (EDR type 15):

- *BATCH_DESCRIPTION* (for voucher batch)
- *NEW_ACCOUNT* (ID of account type)
- *OLD_ACCOUNT* (ID of account type)
- *REDEEMING_ACCT_TYPE* (name of account type)
- *SCENARIO* (voucher scenario number)
- *TYPE_DESCRIPTION* (voucher type)
- *REDEEMING_SUBSCRIBER_ID* (subscriber ID)

Account Activated additional fields

If the account is activated, the following fields are generated:

- *NEW_ACCT_STATE* (always active - A)
- *OLD_ACCT_STATE* (P or D before update)

Reload Bonus additional fields

If the account has a promotional reload bonus configured, the following fields are generated (EDR types 4, 15 and 16):

- *RELOAD_BONUS* (promotion name)
- *RELOAD_BONUS_AMOUNT* (amount applied)
- *RELOAD_BONUS_EXPIRY* (date remaining bonus expires)
- *RELOAD_BONUS_LEFT* (bonus amount remaining)

MSISDN additional fields

If the MSISDN ccsCDRLoader plug-in is installed on the SMS, the following field will be present:

- *MSISDN* (account calling number)

Example EDR 4

```
BILLING_ENGINE_ID=21 | SCP_ID=366273322 | SEQUENCE_NUMBER=488297 |
CDR_TYPE=4 | RECORD_DATE=20040804103532 | ACCT_ID=61 | ACCT_REF_ID=61 |
ACS_CUST_ID=1 | VOUCHER=7609766 | VOUCHER_NUMBER=0000000081 | CS=S |
WALLET_TYPE=1 | ACCOUNT_TYPE=1 | BALANCE_TYPES=1 | BALANCES=1005800 |
COSTS=-1000 | NEW_BALANCE_EXPIRIES= | OLD_BALANCE_EXPIRIES=0
```

Example EDR 15

```
BILLING_ENGINE_ID=21 | SCP_ID=366273322 | SEQUENCE_NUMBER=488297 |
CDR_TYPE=15 | RECORD_DATE=20040803152952 | ACCT_ID=61 | ACCT_REF_ID=61 |
ACS_CUST_ID=1 | REDEEMING_ACCT_REF=61 | VOUCHER=7609766 | VOUCHER_NUMBER=0000000081 |
RESULT=Success
```

Note

The sequence of all fields output in an EDR is not guaranteed.

Voucher Recharge Succeeds using PI (EDR 4,15)

Introduction

Two or three EDRs are created for this event:

- A type 4
- A type 15
- A type 16 when the Rewards plug-in is being used.. See Rewards chapter for the EDR definition.

Mandatory EDR 4 fields

This list identifies the mandatory EDR record fields for voucher recharge succeeds using PI (EDR type 4):

- *ACCOUNT_TYPE* (Product Type ID)
- *ACS_CUST_ID* (ACS Customer ID)
- *BALANCE_TYPES* (existing account)
- *BALANCES* (pre-transaction account balances)
- *COSTS* (rated calls)
- *CS* (*call status, S or D*) (call status, S or D)
- *NEW_BALANCE_EXPIRIES* (dates after voucher recharge)
- *OLD_BALANCE_EXPIRIES* (dates before voucher recharge)
- *PI* (logon name and IP address)
- *TYPE_DESCRIPTION* (voucher type)
- *WALLET_TYPE* (ID of wallet changed)

Optional EDR 4 fields

If they are not present, the ccsCDRLoader voucher plug-in does not process the EDR. For more information about ccsCDRLoader, see Process descriptions.

This list identifies the optional EDR record fields for voucher recharge succeeds using PI (EDR type 4):

- *REFERENCE* (voucher freeform)
- *VOUCHER* - one of:
 - *VOUCHER* (ID of redeemed voucher)
 - *VOUCHER* (serial number of redeemed voucher - 3.1.5)

Mandatory EDR 15 fields

This list identifies the mandatory EDR record fields for voucher recharge succeeds using PI (EDR type 15):

- *ACS_CUST_ID* (ACS Customer ID)
- *BALANCE_EXPIRIES* (period hours)
- *BALANCE_TYPES* (existing account)
- *COSTS* (rated calls)
- *REDEEMING_ACCT_REF* (ID of account)
- *RESULT* (voucher redemption, always Success)
- *VOUCHER* - one of:
 - *VOUCHER* (ID of redeemed voucher)
 - *VOUCHER* (serial number of redeemed voucher - 3.1.5)

Optional EDR 15 fields

This list identifies the optional EDR record fields for voucher recharge succeeds using PI (EDR type 15):

- *BATCH_DESCRIPTION* (for voucher batch)
- *NEW_ACCOUNT* (ID of account type)
- *OLD_ACCOUNT* (ID of account type)
- *REDEEMING_ACCT_TYPE* (name of account type)
- *SCENARIO* (voucher scenario number)
- *TYPE_DESCRIPTION* (voucher type)
- *REDEEMING_SUBSCRIBER_ID* (subscriber ID)

Account Activated additional fields

If the account is activated, the following fields are generated:

- *NEW_ACCT_STATE* (always active - A)

- *OLD_ACCT_STATE* (P or D before update)

Reload Bonus additional fields

If the account has a promotional reload bonus configured, the following fields are generated (EDR types 4, 15 and 16):

- *RELOAD_BONUS* (promotion name)
- *RELOAD_BONUS_AMOUNT* (amount applied)
- *RELOAD_BONUS_EXPIRY* (date remaining bonus expires)
- *RELOAD_BONUS_LEFT* (bonus amount remaining)

MSISDN additional fields

If the MSISDN ccsCDRLoader plug-in is installed on the SMS, the following field will be present:

- *MSISDN* (account calling number)

Example EDR 4

```
BILLING_ENGINE_ID=21|SCP_ID=161986004|SEQUENCE_NUMBER=2|CDR_TYPE=4|
RECORD_DATE=20040804111124|ACCT_ID=61|ACCT_REF_ID=61|ACS_CUST_ID=1|
VOUCHER=7609766|VOUCHER_NUMBER=0000000086|CS=S|PI=adminAT192.168.25.106|
WALLET_TYPE=1|ACCOUNT_TYPE=1|BALANCE_TYPES=1|BALANCES=1006800|
COSTS=-1000|NEW_BALANCE_EXPIRIES=|OLD_BALANCE_EXPIRIES=0
```

Example EDR 15

```
BILLING_ENGINE_ID=21|SCP_ID=161986004|SEQUENCE_NUMBER=2|
CDR_TYPE=15|RECORD_DATE=20040803152952|ACCT_ID=61|ACCT_REF_ID=61|
ACS_CUST_ID=1|REDEEMING_ACCT_REF=61|VOUCHER=7609766|VOUCHER_NUMBER=0000000086|
RESULT=Success
```

Note

The sequence of all fields output in an EDR is not guaranteed.

Voucher Recharge Succeeds using USSD (EDR 4,15)

Introduction

Two or three EDRs are created for this event:

- A type 4
- A type 15
- A type 16 when the Rewards plug-in is being used. See the *Rewards* chapter for the EDR definition.

Mandatory EDR 4 fields

This list identifies the mandatory EDR record fields for voucher recharge succeeds using USSD (EDR type 4):

- *ACCOUNT_TYPE* (Product Type ID)
- *ACS_CUST_ID* (ACS Customer ID)
- *BALANCE_TYPES* (existing account)
- *BALANCES* (pre-transaction account balances)
- *COSTS* (rated calls)
- *CS* (*call status, S or D*) (call status, S or D)
- *NEW_BALANCE_EXPIRIES* (dates after voucher recharge)
- *OLD_BALANCE_EXPIRIES* (dates before voucher recharge)
- *TYPE_DESCRIPTION* (voucher type)
- *WALLET_TYPE* (ID of wallet changed)

Optional EDR 4 fields

If they are not present, the ccsCDRLoader voucher plug-in does not process the EDR. For more information about ccsCDRLoader, see Process descriptions.

This list identifies the optional EDR record fields for voucher recharge succeeds using USSD (EDR type 4):

- *REFERENCE* (voucher freeform)
- *VOUCHER* - one of:
 - *VOUCHER* (ID of redeemed voucher)
 - *VOUCHER* (serial number of redeemed voucher - 3.1.5)

Mandatory EDR 15 fields

This list identifies the mandatory EDR record fields for voucher recharge succeeds using USSD (EDR type 15):

- *ACS_CUST_ID* (ACS Customer ID)
- *BALANCE_EXPIRIES* (period hours)
- *BALANCE_TYPES* (existing account)
- *COSTS* (rated calls)
- *REDEEMING_ACCT_REF* (ID of account)
- *RESULT* (voucher redemption, always Success)
- *VOUCHER* - one of:
 - *VOUCHER* (ID of redeemed voucher)
 - *VOUCHER* (serial number of redeemed voucher - 3.1.5)

Optional EDR 15 fields

This list identifies the optional EDR record fields for voucher recharge succeeds using USSD (EDR type 15):

- *BATCH_DESCRIPTION* (for voucher batch)
- *NEW_ACCOUNT* (ID of account type)
- *OLD_ACCOUNT* (ID of account type)
- *REDEEMING_ACCT_TYPE* (name of account type)
- *SCENARIO* (voucher scenario number)
- *TYPE_DESCRIPTION* (voucher type)
- *REDEEMING_SUBSCRIBER_ID* (subscriber ID)

Account Activated additional fields

If the account is activated, the following fields are generated:

- *NEW_ACCT_STATE* (always active - A)
- *OLD_ACCT_STATE* (P or D before update)

Reload Bonus additional fields

If the account has a promotional reload bonus configured, the following fields are generated (EDR types 4, 15 and 16):

- *RELOAD_BONUS* (promotion name)
- *RELOAD_BONUS_AMOUNT* (amount applied)
- *RELOAD_BONUS_EXPIRY* (date remaining bonus expires)
- *RELOAD_BONUS_LEFT* (bonus amount remaining)

MSISDN additional fields

If the MSISDN ccsCDRLoader plug-in is installed on the SMS, the following field will be present:

- *MSISDN* (account calling number)

Example EDR 4

```
BILLING_ENGINE_ID=1|SCP_ID=114207220|SEQUENCE_NUMBER=139450184|CDR_TYPE=4|
RECORD_DATE=20041216162449|ACCT_ID=46|ACCT_REF_ID=46|ACS_CUST_ID=1|
VOUCHER=7609766|VOUCHER_NUMBER=23439221779469|CS=S|
USSD=VOUCHER_REDEEMED|ACCOUNT_TYPE=23|BALANCE_TYPES=1|
BALANCES=113495,113495|COSTS=1,-20500|NEW_BALANCE_EXPIRIES=,|
OLD_BALANCE_EXPIRIES=0,0|RELOAD_BONUS_AMOUNT=500|
RELOAD_BONUS_LEFT=113494
```

Example EDR 15

```
BILLING_ENGINE_ID=21|SCP_ID=161986004|SEQUENCE_NUMBER=2|  
CDR_TYPE=15|RECORD_DATE=20040803152952|ACCT_ID=61|  
ACCT_REF_ID=61|ACS_CUST_ID=1|REDEEMING_ACCT_REF=61|  
VOUCHER=7609766|VOUCHER_NUMBER=0000000086|RESULT=Success
```

Note

The sequence of all fields output in an EDR is not guaranteed.

Voucher Recharge Fails using Screens or IVR (EDR 4)

Introduction

In this scenario, recharge fails because the account is in either a frozen or suspended state.

A type 4 EDR is created for this event.

Mandatory EDR 4 fields

This list identifies the mandatory EDR record fields for voucher recharge failures using screens or IVR (EDR type 4):

- *ACCOUNT_TYPE* (Product Type ID)
- *ACS_CUST_ID* (ACS Customer ID)
- *BATCH_DESCRIPTION* (for voucher batch)
- *CS* (call status, always D)
- *NACK* (long list of codes)
- *RESULT* (frozen or suspended)
- *TERMINAL* (Network ID)
- *TYPE_DESCRIPTION* (voucher type)
- *USER* (operator logon name)

Optional EDR 4 fields

If they are not present, the ccsCDRLoader voucher plug-in does not process the EDR. For more information about ccsCDRLoader, see Process descriptions.

This list identifies the optional EDR record fields for voucher recharge failures using screens or IVR (EDR type 4):

- *REFERENCE* (voucher freeform)
- *SCENARIO* (voucher scenario number)
- *VOUCHER* - one of:
 - *VOUCHER* (ID of redeemed voucher)
 - *VOUCHER* (serial number of redeemed voucher - 3.1.5)

MSISDN additional fields

If the MSISDN ccsCDRLoader plug-in is installed on the SMS, the following field will be present:

- *MSISDN* (account calling number)

Example EDR 4

```
BILLING_ENGINE_ID=21|SCP_ID=110537566|SEQUENCE_NUMBER=139450184|CDR_TYPE=4|  
RECORD_DATE=20040804105430|ACCT_ID=61|ACCT_REF_ID=61|ACS_CUST_ID=1|  
VOUCHER=7609766|VOUCHER_NUMBER=0000000085|CS=D|RESULT=Frozen Wallet
```

Note

The sequence of all fields output in an EDR is not guaranteed.

Voucher Recharge Fails using Screens or IVR (EDR 15,33)

Introduction

The recharge fails because the voucher details entered are invalid or the voucher is in an invalid state. There are two EDR records created for this event:

- A EDR of type 15
- A EDR of type 33

Mandatory EDR 15 fields

This list identifies the mandatory EDR record fields for voucher recharge failure using screens or IVR (EDR type 15):

- *ACCOUNT_TYPE* (Product Type ID)
- *ACS_CUST_ID* (ACS Customer ID)
- *REDEEMING_ACCT_REF* (ID of account)
- *RESULT* (general cause)
- *VOUCHER* - one of:
 - *VOUCHER* (ID of redeemed voucher)
 - *VOUCHER* (serial number of redeemed voucher - 3.1.5)
 - *VOUCHER_NUMBER* (redeemed voucher)

Optional EDR 15 fields

This list identifies the optional EDR record fields for voucher recharge failures using screens or IVR (EDR type 15):

- *BATCH_DESCRIPTION* (for voucher batch)
- *TERMINAL* (Network ID)

- *TYPE_DESCRIPTION* (voucher type)
- *USER* (operator logon name)
- *REDEEMING_SUBSCRIBER_ID* (subscriber ID)

Mandatory EDR 33 fields

This list identifies the mandatory EDR record fields for voucher recharge failure using screens or IVR (EDR type 33):

- *ACS_CUST_ID*
- *BAD_PINS*
- *TERMINAL*
- *USER*

Optional EDR 33 fields

This list identifies the optional EDR record fields for voucher recharge failures using screens or IVR, when the account is frozen due to the maximum number of bad pins being exceeded (EDR type 33):

- *NEW_ACCT_STATE* (frozen)
- *OLD_ACCT_STATE* (active)

MSISDN additional fields

If the MSISDN ccsCDRLoader plug-in is installed on the SMS, the following field will be present:

- *MSISDN* (account calling number)

Example

```
BILLING_ENGINE_ID=21|SCP_ID=366273322|SEQUENCE_NUMBER=488298|CDR_TYPE=15|
RECORD_DATE=20070719113914|ACCT_ID=61|ACCT_REF_ID=61|ACS_CUST_ID=1|REDEEMING_ACCT_REF=61|
VOUCHER=8709766|VOUCHER_NUMBER=0000000086|BATCH_DESCRIPTION=Test Batch|
TYPE_DESCRIPTION=STANDARD|RESULT=Failed Auth|ACCOUNT_TYPE=24|USER=SU|
TERMINAL=192.168.25.108
```

Example EDR 33

```
BILLING_ENGINE_ID=21|SCP_ID=366273322|SEQUENCE_NUMBER=488298|CDR_TYPE=33|
RECORD_DATE=20070703145823|ACCT_ID=61|ACCT_REF_ID=61|BAD_PINS=1|ACS_CUST_ID=1|
ACCOUNT_TYPE=24|USER=SU|TERMINAL=192.168.25.108
```

Note

The sequence of all fields output in an EDR is not guaranteed.

Voucher Type Recharge

Introduction

A type 47 EDR is created for this event.

Note: The type 47 EDR contains fields identical to a type 4. It is given its own EDR number because it is handled differently from a normal voucher recharge. A type 4 EDR generates a recharge notification from the EDR loader plug-in. In the case of the type 47, the notification is generated by the process calling it. This process can be a control plan, periodic charge or a credit transfer.

Mandatory EDR 47 fields

This list identifies the mandatory EDR record fields for voucher type recharge (EDR type 47):

- *ACCOUNT_TYPE* (Product Type ID)
- *ACS_CUST_ID* (ACS Customer ID)
- *BALANCE_TYPES* (existing account)
- *BALANCES* (pre-transaction account balances)
- *COSTS* (rated calls)
- *CS* (*call status, S or D*) (call status, S or D)
- *NEW_BALANCE_EXPIRIES* (dates after voucher recharge)
- *OLD_BALANCE_EXPIRIES* (dates before voucher recharge)
- *VOUCHER_TYPE* (name)

Optional EDR 47 fields

This list identifies the optional EDR record fields for voucher type recharge (EDR type 47):

- *NEW_ACCT_TYPE* (ID of account after recharge)
- *OLD_ACCT_TYPE* (ID of account before recharge)

6

Rewards

Overview

Introduction

This chapter defines the CCS EDRs for rewards.

Reward Application Successful (EDR 16)

Introduction

All successful balance updates (for example: rated voice calls, voucher recharge, balance update or balance expiry, by whatever mechanism) may produce an EDR type 16 if the Rewards plug-in is being used and Rewards are configured, in addition to the normal update EDR(s).

Mandatory EDR 16 fields

This list identifies the mandatory EDR record fields for successful reward application using any of screens, IVR, PI or USSD (EDR type 16):

- *ACCOUNT_TYPE* (Product Type ID)
- *ACS_CUST_ID* (ACS Customer ID)
- *BALANCE_TYPES* (account changed or created)
- *BALANCES* (pre-call or account creation)
- *COSTS* (rated calls)
- *CS* (*call status, S or D*) (call status, S or D)
- *NEW_BALANCE_EXPIRIES* (dates after voucher recharge)
- *OLD_BALANCE_EXPIRIES* (dates before voucher recharge)
- *RESULT* (voucher redemption, always Success)
- *REWARD* (ID)
- *REWARD_AMOUNTS* (value of reward)
- *REWARD_CATEGORY*
- *REWARD_TYPES* (balance types getting reward)

Optional EDR 16 fields

This list identifies the optional EDR record fields for successful reward application using any of screens, IVR, PI or USSD (EDR type 16):

- *BEARER_TYPE* (bearer type for promotions) (bearer type for rewards)
- *CHANNEL* (for rewards) (for rewards)
- *NEW_ACCT_EXPIRY* (date after update)
- *OLD_ACCT_EXPIRY* (dates before update)
- *REFERENCE* (operator freeform) (rewards)

Account Activated additional fields

If the account is activated, the following fields are generated:

- *NEW_ACCT_STATE* (always active - A)
- *OLD_ACCT_STATE* (P or D before update)

Reload Bonus additional fields

If the account has a promotional reload bonus configured, the following fields are generated (EDR types 4, 15 and 16):

- *RELOAD_BONUS* (promotion name)
- *RELOAD_BONUS_AMOUNT* (amount applied)
- *RELOAD_BONUS_EXPIRY* (date remaining bonus expires)
- *RELOAD_BONUS_LEFT* (bonus amount remaining)

MSISDN additional fields

If the MSISDN ccsCDRLoader plug-in is installed on the SMS, the following field will be present:

- *MSISDN* (account calling number)

Example EDR 16

```
ACCOUNT_TYPE=104|ACCT_ID=325|ACCT_REF_ID=305|ACS_CUST_ID=11|
BALANCES=1|BALANCE_NAMES=Free SMS|BALANCE_TYPES=6|BILLING_ENGINE_ID=1|CDR_TYPE=16|
COSTS=-1|CS=S|NEW_BALANCE_EXPIRIES=0|OLD_ACCOUNT_TYPE=|OLD_BALANCE_EXPIRIES=0|
RECORD_DATE=20120725122635|RESULT=Success|REWARD=295|REWARD_AMOUNTS=1|
REWARD_CATEGORY=TRACKER_THRESHOLD|REWARD_TYPES=6|SCP_ID=0|SEQUENCE_NUMBER=0
```

Note

The sequence of all fields output in an EDR is not guaranteed.

Reward Application Fails using Screens or IVR (EDR 16)

Introduction

All failed balance updates (for example: voucher recharge, balance update or balance expiry, by screens or IVR) will produce an EDR type 16 if the Rewards plug-in is being used, in addition to the normal update failed EDR(s).

Mandatory EDR 16 fields

This list identifies the mandatory EDR record fields for reward application failures using screens or IVR (EDR type 16):

- *ACS_CUST_ID* (ACS Customer ID)
- *CS* (call status, always D)
- *NACK* (long list of codes)
- *REWARD* (ID)
- *REWARD_AMOUNTS* (value of reward)
- *REWARD_CATEGORY*
- *REWARD_TYPES* (balance types getting reward)

Optional EDR 16 fields

This list identifies the optional EDR record fields for reward application failures using screens or IVR (EDR type 16):

- *BATCH_DESCRIPTION* (for voucher batch)

MSISDN additional fields

If the MSISDN ccsCDRLoader plug-in is installed on the SMS, the following field will be present:

- *MSISDN* (account calling number)

Example EDR 16 (Remove21)

```
ACCT_ID=2129|ACCT_REF_ID=2124|ACS_CUST_ID=1|BILLING_ENGINE_ID=4|  
CDR_TYPE=16|CS=D|NACK=BDVR|RECORD_DATE=20071101115704|  
RESULT=Invalid Balance Type|REWARD=62|REWARD_AMOUNTS=1,2|  
REWARD_CATEGORY=TRACKER_THRESHOLD|REWARD_TYPES=5,27|SCP_ID=110537566|  
SEQUENCE_NUMBER=139450184
```

Note

The sequence of all fields output in an EDR is not guaranteed.

7

Voice Calls

Overview

Introduction

This chapter defines the CCS EDRs for voice calls.

Successful National Call (EDR 1)

Mandatory EDR 1 fields

This list identifies the mandatory EDR record fields for a successful national call (CDR type 1):

- *ACCOUNT_TYPE* (Product Type ID)
- *ACS_CUST_ID* (ACS Customer ID)
- *BALANCE_TYPES* - use one of:
 - *BALANCE_TYPES* (account changed or created)
 - *BALANCE_TYPES* (account changed or created) - mid call rate changes
- *BALANCES* - use one of:
 - *BALANCES* (pre-call or account creation)
 - *BALANCES* (pre-call or account creation) - mid call rate changes
- *CASCADE_ID* - use one of:
 - *CASCADE_ID* (balance type cascade IDs)
 - *CASCADE_ID* (balance type cascade IDs) - mid call rate change
- *CLI* - use one of:
 - *CLI* (initiating call number)
 - *CLI* (initiating call number) - mid call rate changes
- *COSTS* - use one of:
 - *COSTS* (rated calls)
 - *COSTS* (rated calls) - mid call rate changes
- *DISCOUNTS* - use one of:
 - *DISCOUNTS* (rated calls)
 - *DISCOUNTS* (rated calls) - mid call rate changes
- *DURATION* (call length)
- *DURATION_CHARGED*

- *DURATION_DELTA*
- *END_CALL_REASON* (reasons for call termination)
- *FCA* (final call address)
- *LAST_RECORD_DATE*
- *LENGTHS* - use one of:
 - *LENGTHS* (rate durations)
 - *LENGTHS* (rate durations) -1end duration
 - *LENGTHS* (rate durations) - mid call rate changes
- *MAX_CHARGE* - use one of:
 - *MAX_CHARGE* (for this call)
 - *MAX_CHARGE* (for this call) - mid call rate changes
- *OGEO_ID* (originating geo node id)
- *RATES* - use one of:
 - *RATES* (rated calls)
 - *RATES* (rated calls) - mid call rate changes
- *SVC_ID* (single tariff rated calls)
- *TCE* (ccs time call ended)
- *TCS* (ccs time call started)
- *TGEO_ID* (terminating geo node id)
- *TN* (ccs called number)
- *WALLET_TYPE* (ID of wallet changed)

Optional EDR 1 fields

This list identifies the optional EDR record fields for a successful national call (CDR type 1):

- *CUG_NAME* (closed user group)
- *OVERRIDDEN_TARIFF_PLAN* (ID)
- *RELC* (inap release cause)
- *TARIFF_CODE* (name)

Partial EDR additional fields

Enabling of Mid-Session EDRs production creates Partial EDRs. Either the Commit Volume Threshold or Mid-Session EDRs parameters are enabled (**Rating Management > Reservation Config > New Reservation Config** screen).

These additional tags are on all the partial EDRs, but not on the final, complete EDR:

- *MID_SESSION* (partial EDR)
- *SESSION_SEQUENCE* (partial EDR)

Timed-out reservation confirmation additional fields

If a confirmed reservation times out, these tags will be added to the EDR.

- *RNCF* (Reservation Not Charged For)
- *TIMED_OUT* (reservation confirmation)

Account Activated additional fields

If the account is activated, the following fields are generated:

- *NEW_ACCT_STATE* (always active - A)
- *OLD_ACCT_STATE* (P or D before update)

Cross balance type discount additional fields

If the cross balance type discounting has been applied during the call, the following fields will be present:

- *CBTD_BALANCE_TYPES* (list to apply to discounts)
- *CBTD_BALANCE_TYPES* (list to apply to discounts) - mid call rate changes
- *CBTD_BALANCES* (value for each cross balance type)
- *CBTD_BALANCES* (value for each cross balance type) - mid call rate change
- *CBTD_CASCADE_ID* (used for this call)
- *CBTD_CASCADE_ID* (used for this call) - mid call rate change
- *CBTD_COSTS* (costs applied to each cross balance type)
- *CBTD_COSTS* (costs applied to each cross balance type) - mid call rate changes
- *CBTD_DISCOUNTS* (discounts applied to balance types)
- *CBTD_DISCOUNTS* (discounts applied to balance types) - mid call rate changes

MSISDN additional fields

If the MSISDN ccsCDRLoader plug-in is installed on the SMS, the following field will be present:

- *MSISDN* (account calling number)

Mobile number portability additional fields

If the Mobile Number Portability (MNP) software is installed, the following fields will be present:

- *PORTED* (name of porting carrier)

Bucket level costs additional field

If addBucketLevelCostsInEdr configuration is enabled, the following field will be present:

- *BUCKET_LEVEL_COSTS*

Example EDR 1 for single tariff rated call

```
BILLING_ENGINE_ID=21|SCP_ID=366273322|SEQUENCE_NUMBER=487291|CDR_TYPE=1|
RECORD_DATE=20070423190107|ACCT_ID=83|ACCT_REF_ID=83|CLI=01206233252|ACS_CUST_ID=1|
BALANCE_TYPES=1|BALANCES=49880|COSTS=120|ACCOUNT_TYPE=22|CASCADE_ID=44|RATES=60|
LENGTHS=2810.00|DISCOUNTS=0|MAX_CHARGE=500|DURATION=120.00|DURATION_CHARGED=120.00|
TN=01473|TCS=20070423181310|TCE=20070423181510|CS=S|DISCOUNT_TYPE=S*W*R|WALLET_TYPE=1|
FCA=01473254338|END_CALL_REASON=14
```

Example EDR 1 for multi tariff rated call

```
BILLING_ENGINE_ID=42|SCP_ID=789955221|SEQUENCE_NUMBER=11775353|CDR_TYPE=
1|RECORD_DATE=20070430180652|
ACCT_ID=261|ACCT_REF_ID=255|CLI=6610|ACS_CUST_ID=1|BALANCE_TYPES=1,2|BALANCES=1
80,100|COSTS=60,45|ACCOUNT_TYPE=1|
CASCADE_ID=1,49|RATES=aa:10,10,10,20,20,30,30,30,bb:5,10,20,20,15,15,20,20|
LENGTHS=aa:30.00,15.00,15.00,30.00,30.00,30.00,60.00,0.00,bb:30.00,15.00,15.00,
30.00,30.00,30.00,60.00,0.00|
DISCOUNTS=aa:0,0,0,0,0,0,0,0,bb:0,0,0,0,0,0,0|
MAX_CHARGE=-1|DURATION=180.00|DURATION_CHARGED=180.00|TN=6610|TCS=20070430180659|
TCE=20070430180959|CS=S|DISCOUNT_TYPE=BASIC|WALLET_TYPE=1|FCA=6610|END_CALL_REASON=16
```

Example Account Activated

```
BILLING_ENGINE_ID=21|SCP_ID=366273322|SEQUENCE_NUMBER=487291|CDR_TYPE=1|
RECORD_DATE=20040803142342|ACCT_ID=83|ACCT_REF_ID=83|CLI=01206233252|ACS_CUST_ID=1|
BALANCE_TYPES=1|BALANCES=1000|COSTS=1|ACCOUNT_TYPE=1|CASCADE_ID=1|RATES=50,25|
LENGTHS=120.00,40.00|DISCOUNTS=0,0|MAX_CHARGE=1|DURATION=160|DURATION_CHARGED=160|
TN=01473289900|TCS=20040803141934|TCE=20040803142034|CS=S|OLD_ACCT_STATE=P|
NEW_ACCT_STATE=A|DISCOUNT_TYPE=S*W*R|WALLET_TYPE=1|END_CALL_REASON=14
```

Example Account Activated - MSISDN

```
BILLING_ENGINE_ID=21|SCP_ID=366273322|SEQUENCE_NUMBER=487291|CDR_TYPE=1|
RECORD_DATE=20040803142342|ACCT_ID=83|ACCT_REF_ID=83|CLI=01206233252|ACS_CUST_ID=1|
BALANCE_TYPES=1|BALANCES=1000|COSTS=28|ACCOUNT_TYPE=1|CASCADE_ID=1|RATES=50,25|
LENGTHS=120.00,40.00|DISCOUNTS=450000,560000|MAX_CHARGE=500|DURATION=160|
DURATION_CHARGED=160|TN=01473289900|TCS=20040803141934|TCE=20040803142034|CS=S|
DISCOUNT_TYPE=S*W*R|WALLET_TYPE=1|MSISDN=01206233252|END_CALL_REASON=14
```

Note

The sequence of all fields output in an EDR is not guaranteed.

Commit Reservation (EDR 1)

Mandatory EDR 1 fields

This list identifies the mandatory EDR record fields when a Commit Reservation has been performed (CDR type 1):

- *ACCOUNT_TYPE* (Product Type ID)
- *ACS_CUST_ID* (ACS Customer ID)

- *BALANCE_TYPES* - use one of:
 - *BALANCE_TYPES* (account changed or created)
 - *BALANCE_TYPES* (account changed or created) - mid call rate changes
- *BALANCES* - use one of:
 - *BALANCES* (pre-call or account creation)
 - *BALANCES* (pre-call or account creation) - mid call rate changes
- *CASCADE_ID* - use one of:
 - *CASCADE_ID* (balance type cascade IDs)
 - *CASCADE_ID* (balance type cascade IDs) - mid call rate change
- *CLI* - use one of:
 - *CLI* (initiating call number)
 - *CLI* (initiating call number) - mid call rate changes
- *COSTS* - use one of:
 - *COSTS* (rated calls)
 - *COSTS* (rated calls) - mid call rate changes
- *CS* (*call status, S or D*) (call status, S or D)
- *DISCOUNTS* - use one of
 - *DISCOUNTS* (rated calls)
 - *DISCOUNTS* (rated calls) - mid call rate changes
- *DISCOUNT_TYPE* (applied to this call) - R*W
- *DURATION* (call length)
- *DURATION_CHARGED*
- *END_CALL_REASON* (*reasons for call termination*)
- *LENGTHS* - use one of:
 - *LENGTHS* (rate durations)
 - *LENGTHS* (rate durations) -1end duration
 - *LENGTHS* (rate durations) - mid call rate changes
- *MAX_CHARGE* - use one of:
 - *MAX_CHARGE* (for this call)
 - *MAX_CHARGE* (for this call) - mid call rate changes
- *MFILE* (for rating data)
- *OPERATOR_RELEASED* (commit/revoke reservation)
- *RATES* - use one of:
 - *RATES* (rated calls)
 - *RATES* (rated calls) - mid call rate changes
- *TCE* (ccs time call ended)
- *TCS* (ccs time call started)
- *TERMINAL* (Network ID)

- *TN* (ccs called number)
- *USER* (operator logon name)

Example EDR 1 for reservation commit

```
BILLING_ENGINE_ID=21|SCP_ID=366273322|SEQUENCE_NUMBER=487291|CDR_TYPE=1|
RECORD_DATE=20070423190107|ACCT_ID=83|ACCT_REF_ID=83|CLI=49393520|BALANCE_TYPES=1|
BALANCES=89140|COSTS=540|RATES=60|LENGTHS=-1|DISCOUNTS=0|MAX_CHARGE=2000|CASCADE_ID=1|
ACS_CUST_ID=1|ACCOUNT_TYPE=21|DURATION=540.00|DURATION_CHARGED=540.00|TN=47777777|
TCS=20100602225949|TCE=20100602230025|CS=S|DISCOUNT_TYPE=R*W|MFILE=20100602203530|
USER=SU|TERMINAL=192.168.2.68|OPERATOR_RELEASED=1|END_CALL_REASON=15
```

Revoke Reservation (EDR 1)

Mandatory EDR 1 fields

This list identifies the mandatory EDR record fields when a Revoke Reservation has been performed (CDR type 1):

- *ACCOUNT_TYPE* (Product Type ID)
- *ACS_CUST_ID* (ACS Customer ID)
- *CLI* - use one of:
 - *CLI* (initiating call number)
 - *CLI* (initiating call number) - mid call rate changes
- *CS* (*call status, S or D*) (call status, S or D)
- *DISCOUNT_TYPE* (applied to this call) - R*W
- *DURATION* (call length)
- *DURATION_CHARGED*
- *END_CALL_REASON* (*reasons for call termination*)
- *MFILE* (for rating data)
- *OPERATOR_RELEASED* (commit/revoke reservation)
- *TCE* (ccs time call ended)
- *TCS* (ccs time call started)
- *TERMINAL* (Network ID)
- *TN* (ccs called number)
- *USER* (operator logon name)

Example EDR 1 for single tariff rated call

```
BILLING_ENGINE_ID=21|SCP_ID=366273322|SEQUENCE_NUMBER=487291|CDR_TYPE=1|
RECORD_DATE=20070423190107|ACCT_ID=83|ACCT_REF_ID=83|ACS_CUST_ID=1|ACCOUNT_TYPE=21|
DURATION=0.00|DURATION_CHARGED=60|TN=47777777|TCS=20100602034410|TCE=20100602034432|CS=S|
DISCOUNT_TYPE=R*W|MFILE=20100602032245|OPERATOR_RELEASED=1|USER=SU|TERMINAL=192.168.2.68|
CLI=49393520
```

Declined National Call

Mandatory EDR 1 fields

This list identifies the mandatory EDR record fields for a declined national call (EDR type 1):

- *ACCOUNT_TYPE* (Product Type ID)
- *ACS_CUST_ID* (ACS Customer ID)
- *CLI* (initiating call number)
- *NACK* (long list of codes)
- *TCS* (ccs time call started)
- *TN* (ccs called number)
- *WALLET_TYPE* (ID of wallet changed)

Optional EDR 1 fields

This list identifies the optional EDR record fields for a declined national call (EDR type 1):

- *CUG_NAME* (closed user group)

Account Activated additional fields

If the account is activated, the following fields are generated:

- *NEW_ACCT_STATE* (always active - A)
- *OLD_ACCT_STATE* (P or D before update)

MSISDN additional fields

If the MSISDN ccsCDRLoader plug-in is installed on the SMS, the following field will be present:

- *MSISDN* (account calling number)

Mobile number portability additional fields

If the Mobile Number Portability (MNP) software is installed, the following fields will be present:

- *PORTED* (name of porting carrier)

Example EDR 1 for declined national call

```
BILLING_ENGINE_ID=21|SCP_ID=230612530|SEQUENCE_NUMBER=487291|CDR_TYPE=1|
RECORD_DATE=20070703121758|ACCT_ID=83|ACCT_REF_ID=83|CLI=01206233252|TN=01473289900|
TCS=20070725124332|CS=D|ACCOUNT_TYPE=15|NACK=INSF|WALLET_TYPE=1|
ACS_CUST_ID=1END_CALL_REASON=13
```

Example Account Activated

```
BILLING_ENGINE_ID=21 | SCP_ID=230612530 | SEQUENCE_NUMBER=487291 | CDR_TYPE=1 |
RECORD_DATE=20040803121758 | ACCT_ID=83 | ACCT_REF_ID=83 | CLI=01206233252 | TN=01473289900 |
TCS=20040625124332 | CS=D | ACCOUNT_TYPE=15 | NACK=INSF | WALLET_TYPE=1 | ACS_CUST_ID=1 |
OLD_ACCT_STATE=P | NEW_ACCT_STATE=A | END_CALL_REASON=14
```

Example MSISDN

```
BILLING_ENGINE_ID=21 | SCP_ID=230612530 | SEQUENCE_NUMBER=487291 | CDR_TYPE=1 |
RECORD_DATE=20040803121758 | ACCT_ID=83 | ACCT_REF_ID=83 | CLI=01206233252 | TN=01473289900 |
TCS=20040625124332 | CS=D | ACCOUNT_TYPE=15 | NACK=INSF | WALLET_TYPE=1 | ACS_CUST_ID=1 |
OLD_ACCT_STATE=P | NEW_ACCT_STATE=A | MSISDN=01206233252 | END_CALL_REASON=14
```

Note

The sequence of all fields output in an EDR is not guaranteed.

Direct Amount Charge (EDR 6)

Mandatory EDR 23 fields

This list identifies the mandatory EDR record fields for a direct amount charge (EDR type 6):

- *ACCOUNT_TYPE* (Product Type ID)
- *APPLICATION_DESC* (application freeform)
- *BALANCE_TYPES* (account changed or created)
- *BALANCES* (pre-call or account creation)
- *CASCADE_ID* (balance type cascade IDs)
- *COSTS* (rated calls)
- *CS* (call status, S or D) (call status, S or D)
- *NEW_ACCT_EXPIRY* (date after update)
- *NEW_ACCT_STATE* (after update)
- *NEW_BALANCE_EXPIRIES* (date after balance update)
- *OGEO_ID* (originating geo node id)
- *OLD_ACCT_STATE* (before update)
- *OLD_ACCT_EXPIRY* (dates before update)
- *OLD_BALANCE_EXPIRIES* (dates before voucher recharge)
- *REFERENCE* (OSA bonus)
- *TCE* (ccs time call ended)
- *TCS* (ccs time call started)
- *TGEO_ID* (terminating geo node id)
- *WALLET_TYPE* (ID of wallet recharged)

Note: See *EDR header fields* for a list of fields common to every EDR.

Note

The sequence of all fields output in an EDR is not guaranteed.

8

Freeform Recharges

Overview

Introduction

This chapter defines the CCS EDRs for freeform recharges.

Freeform Recharge Succeeds using the GUI (EDR 8)

Mandatory EDR 8 fields

The recharge succeeds where the account is credited.

This list identifies the mandatory EDR record fields for a successful freeform recharge using the GUI (EDR type 8):

- *ACCOUNT_TYPE* (Product Type ID)
- *ACS_CUST_ID* (ACS Customer ID)
- *BALANCE_TYPES* (existing account)
- *BALANCES* (pre-transaction account balances)
- *BONUS_TYPE* (name)
- *COSTS* (rated calls)
- *CS* (*call status, S or D*) (call status, S or D)
- *NEW_BALANCE_EXPIRIES* (dates after voucher recharge)
- *OLD_BALANCE_EXPIRIES* (dates before voucher recharge)
- *REFERENCE* (operator freeform)
- *RELOAD_BONUS* (promotion name)
- *RELOAD_BONUS_AMOUNT* (amount applied)
- *RELOAD_BONUS_EXPIRY* (date remaining bonus expires)
- *RELOAD_BONUS_LEFT* (bonus amount remaining)
- *RESULT* (voucher redemption, always Success)
- *TERMINAL* (Network ID)
- *USER* (operator logon name)
- *WALLET_TYPE* (ID of wallet changed)

Optional EDR 8 fields

This list identifies the optional EDR record fields for a freeform recharge succeeds using the GUI (EDR type 8):

- *ADJUSTMENT* (generated by an adjustment)
- *BEARER_TYPE* (bearer type for promotions) (bearer type for rewards)
- *CHANNEL* (for rewards) (for rewards)
- *REVERSE_CHARGE* (generated by a reverse charge)
- *NEW_ACCT_STATE* (after update)
- *OLD_ACCT_STATE* (before update)

Note: The *NEW_ACCT_STATE* and *OLD_ACCT_STATE* tags will always be present when the freeform recharge causes a change to the wallet state.

MSISDN additional fields

If the MSISDN ccsCDRLoader plug-in is installed on the SMS, the following field will be present:

- *MSISDN* (account calling number)

Example EDR 8 for freeform succeeds

```
BILLING_ENGINE_ID=21|SCP_ID=110537566|SEQUENCE_NUMBER=139450184|CDR_TYPE=8|
RECORD_DATE=20040804132135|ACCT_ID=61|ACCT_REF_ID=61|USER=SU|TERMINAL=192.168.25.108|
RESULT=Success|BONUS_TYPE=CUSTOM|CS=S|REFERENCE=FreeForm Recharge|ACCOUNT_TYPE=1|
BALANCE_TYPES=1|BALANCES=1000|COSTS=-100|OLD_BALANCE_EXPIRIES=0|NEW_BALANCE_EXPIRIES=0|
ACS_CUST_ID=1|WALLET_TYPE=1
```

Example MSISDN

```
BILLING_ENGINE_ID=21|SCP_ID=110537566|SEQUENCE_NUMBER=13950184|CDR_TYPE=8|
RECORD_DATE=20040804132135|ACCT_ID=61|ACCT_REF_ID=61|USER=SU|RESULT=Success|CLI=1234|
REFERENCE=FreeForm Recharge|ACCOUNT_TYPE=1|OLD_ACCT_EXPIRY=0|NEW_ACCT_EXPIRY=0|
MAX_CONCURRENT=10|NEW_LAST_USE=20040804132122|BALANCE_TYPES=1|BALANCES=1000|COSTS=-100|
OLD_BALANCE_EXPIRIES=0|NEW_BALANCE_EXPIRIES=0|ACS_CUST_ID=1|MSISDN=1234
```

Note

The sequence of all fields output in an EDR is not guaranteed.

Freeform Recharge Succeeds using PI (EDR 8)

Mandatory EDR 8 fields

The recharge succeeds where the account is credited.

This list identifies the mandatory EDR record fields for a successful freeform recharge using PI (EDR type 8):

- *ACCOUNT_TYPE* (Product Type ID)

- *ACS_CUST_ID* (ACS Customer ID)
- *BALANCE_TYPES* (existing account)
- *BALANCES* (pre-transaction account balances)
- *BUCKET_IDS* (within balance type recharged)
- *COSTS* (rated calls)
- *NEW_ACCT_EXPIRY* (date after update)
- *NEW_BALANCE_EXPIRIES* (dates after voucher recharge)
- *OLD_ACCT_EXPIRY* (dates before update)
- *OLD_BALANCE_EXPIRIES* (dates before voucher recharge)
- *PI* (logon name and IP address)
- *RELOAD_BONUS* (promotion name)
- *RELOAD_BONUS_AMOUNT* (amount applied)
- *RELOAD_BONUS_EXPIRY* (date remaining bonus expires)
- *RELOAD_BONUS_LEFT* (bonus amount remaining)
- *WALLET_TYPE* (ID of wallet changed)

Optional EDR 8 fields

This list identifies the optional EDR record fields for a freeform recharge succeeds using PI (EDR type 8):

- *BEARER_TYPE* (*bearer type for promotions*) (bearer type for rewards)
- *CHANNEL* (*for rewards*) (for rewards)
- *NEW_ACCT_STATE* (after update)
- *OLD_ACCT_STATE* (before update)
- *REFERENCE* (from pi reference)

Note: The *NEW_ACCT_STATE* and *OLD_ACCT_STATE* tags will always be present when the freeform recharge causes a change to the wallet state.

MSISDN additional fields

If the MSISDN ccsCDRLoader plug-in is installed on the SMS, the following field will be present:

- *MSISDN* (account calling number)

Platform dependant additional fields

Depending on the installed platform, the following field will be present:

- *COMPONENT* (from pi command reference)

Example EDR 8 for freeform succeeds

```
BILLING_ENGINE_ID=21 | SCP_ID=161986004 | SEQUENCE_NUMBER=12 | CDR_TYPE=8 |  
RECORD_DATE=20070704141927 | ACCT_ID=61 | ACCT_REF_ID=61 | ACS_CUST_ID=1 | BALANCES=1000 |
```



```
BALANCE_TYPES=1|BUCKET_IDS=45844|COSTS=-100|NEW_BALANCE_EXPIRIES=|OLD_BALANCE_EXPIRIES=|
PI=adminAT192.168.25.106|OLD_ACCT_EXPIRY=0|NEW_ACCT_EXPIRY=0|WALLET_TYPE=1|ACCOUNT_TYPE=1
```

Example MSISDN

```
BILLING_ENGINE_ID=21|SCP_ID=161986004|SEQUENCE_NUMBER=12|CDR_TYPE=8|
RECORD_DATE=20040804141927|ACCT_ID=61|ACCT_REF_ID=61|ACS_CUST_ID=1|BALANCES=1000|
BALANCE_TYPES=1|BUCKET_IDS=45844|COSTS=-100|CS=S|NEW_BALANCE_EXPIRIES=|
OLD_BALANCE_EXPIRIES=|PI=adminAT192.168.25.106|REFERENCE=PIFreeForm|WALLET_TYPE=1|
ACCOUNT_TYPE=1|LAST_USED=200401011234|MSISDN=1394111111
```

Note

The sequence of all fields output in an EDR is not guaranteed.

Freeform Recharge Succeeds using PI (EDR 2)

Mandatory EDR 2 fields

The recharge succeeds where the account is debited.

This list identifies the mandatory EDR record fields for a successful freeform recharge using PI (EDR type 2):

- *ACS_CUST_ID* (ACS Customer ID)
- *BALANCE_TYPES* (existing account)
- *BALANCES* (pre-transaction account balances)
- *BONUS_TYPE* (name)
- *COSTS* (rated calls)
- *CS* (call status, S or D) (call status, S or D)
- *NEW_BALANCE_EXPIRIES* (dates after voucher recharge)
- *OLD_BALANCE_EXPIRIES* (dates before voucher recharge)
- *PI* (logon name and IP address)
- *REFERENCE* (operator freeform)
- *RESULT* (voucher redemption, always Success)
- *WALLET_TYPE* (ID of wallet changed)

MSISDN additional fields

If the MSISDN ccsCDRLoader plug-in is installed on the SMS, the following field will be present:

- *MSISDN* (account calling number)

Example EDR 2 for freeform succeeds

```
BILLING_ENGINE_ID=21|SCP_ID=161986004|SEQUENCE_NUMBER=13|CDR_TYPE=2|
RECORD_DATE=20040804141927|ACCT_ID=61|ACCT_REF_ID=61|ACS_CUST_ID=1|BALANCES=1100|
BALANCE_TYPES=1|RESULT=Success|COSTS=100|CS=S|NEW_BALANCE_EXPIRIES=|
```

```
OLD_BALANCE_EXPIRIES=|PI=adminAT192.168.25.106|REFERENCE=PI FreeForm|WALLET_TYPE=1|
BONUS_TYPE=CUSTOM|ACCOUNT_TYPE=1|OLD_ACCT_EXPIRY=0|NEW_ACCT_EXPIRY=0
```

Example MSISDN

```
BILLING_ENGINE_ID=21|SCP_ID=161986004|SEQUENCE_NUMBER=13|CDR_TYPE=2|
RECORD_DATE=20040804141927|ACCT_ID=61|ACCT_REF_ID=61|ACS_CUST_ID=1|BALANCES=1100|
BALANCE_TYPES=1|BUCKET_IDS=45844|COSTS=100|CS=S|NEW_BALANCE_EXPIRIES=|
OLD_BALANCE_EXPIRIES=|PI=adminAT192.168.25.106|REFERENCE=PI FreeForm|WALLET_TYPE=1|
ACCOUNT_TYPE=1|OLD_ACCT_EXPIRY=0|NEW_ACCT_EXPIRY=0|MSISDN=1394111111
```

Note

The sequence of all fields output in an EDR is not guaranteed.

Freeform Recharge Fails using PI (EDR 2, 8)

Mandatory EDR 2 fields

A EDR type 2 will be produced for a charge attempt, and a EDR type 8 will be produced for a refund attempt.

This list identifies the mandatory EDR record fields for an unsuccessful PI promotional recharge using PI:

- *ACCOUNT_TYPE* (Product Type ID)
- *ACS_CUST_ID* (ACS Customer ID)
- *BONUS_TYPE* (name)
- *CS* (call status, always D)
- *NACK* (freeform recharge list)
- *PI* (logon name and IP address)
- *REFERENCE* (from pi reference)
- *RESULT* (pi failure)
- *WALLET_TYPE* (ID of wallet changed)

MSISDN additional fields

If the MSISDN ccsCDRLoader plug-in is installed on the SMS, the following field will be present:

- *MSISDN* (account calling number)

Example EDR 8 for freeform fails

```
BILLING_ENGINE_ID=21|SCP_ID=161986004|SEQUENCE_NUMBER=12|CDR_TYPE=8|
RECORD_DATE=20070704141927|ACCT_ID=61|ACCT_REF_ID=61|ACS_CUST_ID=1|BONUS_TYPE=CUSTOM|
CS=D|PI=adminAT192.168.25.106|REFERENCE=PI FreeForm|WALLET_TYPE=1|NACK=WDISP|
ACCOUNT_TYPE=1|RESULT=Frozen Wallet
```

Example MSISDN

```
BILLING_ENGINE_ID=21|SCP_ID=161986004|SEQUENCE_NUMBER=12|CDR_TYPE=8|  
RECORD_DATE=20040804141927|ACCT_ID=61|ACCT_REF_ID=61|ACS_CUST_ID=1|CS=D|  
PI=adminAT192.168.25.106|REFERENCE=PI FreeForm|WALLET_TYPE=1|NACK=NRCH|ACCOUNT_TYPE=1|  
MSISDN=1394111111
```

Note

The sequence of all fields output in an EDR is not guaranteed.

9

Credit Card Recharges

Overview

Introduction

This chapter defines the CCS EDRs for credit card recharges.

Credit Card Recharge Succeeds using Screens (EDR 9)

Mandatory EDR 9 fields

This list identifies the mandatory EDR record fields for a successful credit card recharge using screens (EDR type 9):

- *ACCOUNT_TYPE* (Product Type ID)
- *ACS_CUST_ID* (ACS Customer ID)
- *BALANCE_TYPES* (existing account)
- *BALANCES* (pre-transaction account balances)
- *BONUS_TYPE* (name)
- *COSTS* (rated calls)
- *CS* (*call status, S or D*) (call status, S or D)
- *NEW_BALANCE_EXPIRIES* (dates after voucher recharge)
- *OLD_BALANCE_EXPIRIES* (dates before voucher recharge)
- *REFERENCE* (operator freeform)
- *RESULT* (voucher redemption, always Success)
- *TERMINAL* (Network ID)
- *USER* (operator logon name)
- *WALLET_TYPE* (ID of wallet changed)

MSISDN additional fields

If the MSISDN ccsCDRLoader plug-in is installed on the SMS, the following field will be present:

- *MSISDN* (account calling number)

Example EDR 9 for cc recharge

```
BILLING_ENGINE_ID=21 | SCP_ID=175677458 | SEQUENCE_NUMBER=14578 | CDR_TYPE=9 |  
RECORD_DATE=20070716035736 | ACCT_ID=61 | ACCT_REF_ID=61 | RESULT=Success | REFERENCE=Credit  
Card Recharge |  
ACCOUNT_TYPE=24 | BALANCE_TYPES=1 | BONUS_TYPE=CUSTOM | BALANCES=1000 | COSTS=-100 | CS=S |  
OLD_BALANCE_EXPIRIES=0 | NEW_BALANCE_EXPIRIES=0 | ACS_CUST_ID=1 | TERMINAL=192.168.25.108 |  
USER=SU | WALLET_TYPE=1
```

Note

The sequence of all fields output in an EDR is not guaranteed.

Credit Card Recharge Succeeds using PI (EDR 9)

Mandatory EDR 9 fields

The recharge succeeds where the REFERENCE field of the EDR record has a CC prefix indicating this is a credit card recharge that was initiated through the IVR and the PI was used to recharge the account.

This list identifies the mandatory EDR record fields for a successful credit card recharge using PI (EDR type 9):

- *ACCOUNT_TYPE* (Product Type ID)
- *ACS_CUST_ID* (ACS Customer ID)
- *BALANCE_TYPES* (existing account)
- *BALANCES* (pre-transaction account balances)
- *COSTS* (rated calls)
- *CS* (call status, S or D) (call status, S or D)
- *NEW_BALANCE_EXPIRIES* (dates after voucher recharge)
- *OLD_BALANCE_EXPIRIES* (dates before voucher recharge)
- *PI* (logon name and IP address)
- *REFERENCE* (credit card reference, always cc)
- *STATE* (of recharge)
- *WALLET_TYPE* (ID of wallet recharged)

Optional EDR 9 fields

This list identifies the optional EDR record fields for a successful credit card recharge using PI (EDR type 9):

- *BONUS_TYPE* (name)

MSISDN additional fields

If the MSISDN ccsCDRLoader plug-in is installed on the SMS, the following field will be present:

- *MSISDN* (account calling number)

Example EDR 9 for cc succeeds

```
BILLING_ENGINE_ID=21|SCP_ID=161986004|SEQUENCE_NUMBER=15|CDR_TYPE=9|  
RECORD_DATE=20040804141927|ACCT_ID=61|ACCT_REF_ID=61|ACS_CUST_ID=1|BALANCES=1000|  
BALANCE_TYPES=1|COSTS=-100|CS=S|NEW_BALANCE_EXPIRIES=|OLD_BALANCE_EXPIRIES=|  
PI=adminAT192.168.25.106|REFERENCE=CC040804028091|STATE=verified|WALLET_TYPE=1
```

Note

The sequence of all fields output in an EDR is not guaranteed.

10

Voucher Freeform Recharges

Overview

Introduction

This chapter defines the CCS EDRs for voucher freeform recharges.

Voucher Freeform Recharge Succeeds using Screens (EDR 10)

Mandatory EDR 10 fields

This list identifies the mandatory EDR record fields for a successful voucher freeform recharge using screens (EDR type 10):

- *ACCOUNT_TYPE* (Product Type ID)
- *ACS_CUST_ID* (ACS Customer ID)
- *BALANCE_TYPES* (existing account)
- *BALANCES* (pre-transaction account balances)
- *BONUS_TYPE* (name)
- *COSTS* (rated calls)
- *CS* (*call status, S or D*) (call status, S or D)
- *NEW_BALANCE_EXPIRIES* (dates after voucher recharge)
- *OLD_BALANCE_EXPIRIES* (dates before voucher recharge)
- *REFERENCE* (voucher freeform)
- *RESULT* (voucher redemption, always Success)
- *TERMINAL* (Network ID)
- *USER* (operator logon name)
- *WALLET_TYPE* (ID of wallet changed)

Mandatory EDR 53 fields

MSISDN additional fields

If the MSISDN ccsCDRLoader plug-in is installed on the SMS, the following field will be present:

- *MSISDN* (account calling number)

Example EDR 10 for voucher ff succeeds

```
BILLING_ENGINE_ID=21|SCP_ID=175677458|SEQUENCE_NUMBER=12457|CDR_TYPE=10|  
RECORD_DATE=20070716103449|ACCT_ID=61|ACCT_REF_ID=61|ACCOUNT_TYPE=24|ACS_CUST_ID=1|  
BALANCES=1000|BALANCE_TYPES=1|RESULT=Success|CS=S|  
REFERENCE=Voucher Freeform Recharge|COSTS=-100|OLD_BALANCE_EXPIRIES=0|BONUS_TYPE=CUSTOM|  
NEW_BALANCE_EXPIRIES=0|ACS_CUST_ID=1|USER=SU|TERMINAL=192.168.25.108|WALLET_TYPE=1
```

Note

The sequence of all fields output in an EDR is not guaranteed.

11

Voucher Batch Deletion

Overview

Introduction

This chapter defines the CCS EDRs for voucher batch deletion using Screens.

Voucher Batch Deletion using Screens (EDR 53)

The following properties must be set in the **ccs_voucher_reference_part.cfg** file (path: /IN/service_packages/CCSVCHRPART/etc/ccs_voucher_reference_part.cfg) in the SMS.

- PARTITION_FILE_ARCHIVE_DIRECTORY=/IN/service_packages/CCSVCHRPART/tmp/
- DO_MANUAL_FILE_ARCHIVE=1
- MANUAL_FILE_ARCHIVE_DIRECTORY=/IN/service_packages/CCSVCHRPART/tmp/
- DO_OTHER_FILE_ARCHIVE=1
- OTHER_FILE_ARCHIVE_DIRECTORY=/IN/service_packages/CCSVCHRPART/tmp/

Mandatory EDR 53 fields

This list identifies the mandatory EDR record fields for a successful voucher batch deletion using screens (EDR type 53):

- *ACCT_ID* (changed wallet ID)
- *ACCT_REF_ID* (changed account ID)
- *ACS_CUST_ID* (ACS Customer ID)
- *STATE* (of recharge)
- *VOUCHER_BATCH* (for voucher batch)
- *VOUCHER_NUMBER* (redeemed voucher)

Example EDR 53 (Remove91)

```
BILLING_ENGINE_ID=3|SCP_ID=|SEQUENCE_NUMBER=|
RECORD_DATE=20180412123812|ACCT_ID=|ACCT_REF_ID=|
REDEEMING_SUBSCRIBER_ID=|CDR_TYPE=53|ACS_CUST_ID=11|
BE_VOUCHER_ENGINE_ID=3|CREATION_DATE=20180412123653|
PRIVATE_SECRET=050F308723B5B9D6752A1C5F4D98A4A9B1C65966DFA79555567F982
F010BC6B7AFDBC39D03E72309865C18E5DDC12DE82790748FA23C0F4F236A370986A5
CC4E|REDEEMED_DATE=|REDEEMING_ACCT_REF_ID=|STATE=A|
VOUCHER_BATCH=35|VOUCHER_NUMBER=20051|SCENARIO=2|BARCODE=2232|
TEXT=SAMPLE|CARD_DESIGN=0|DISTRIBUTOR_CHANNEL=WHOLESALE|
```

```
RETAIL_CHANNEL=RETAIL|PROVISIONING_DATE=20180412123702|  
FREE_TEXT_FIELD_1=FREETEXT1|FREE_TEXT_FIELD_2=FREETEXT2|  
FREE_TEXT_FIELD_3=FREETEXT3|
```

Note

The sequence of all fields output in an EDR is not guaranteed.

12

Periodic Charge

Overview

Introduction

This chapter defines the CCS EDRs for periodic charges.

Periodic Charge Recharge Succeeds (EDR 49)

Mandatory EDR 49 fields

This list identifies the mandatory EDR record fields for a successful recharge from a periodic charge (EDR type 49):

- *ACCOUNT_TYPE* (Product Type ID)
- *ACS_CUST_ID* (ACS Customer ID)
- *BALANCE_TYPES* (existing account)
- *BALANCES* (pre-transaction account balances)
- *COSTS* (rated calls)
- *NEW_BALANCE_EXPIRIES* (dates after voucher recharge)
- *OLD_BALANCE_EXPIRIES* (dates before voucher recharge)
- *VOUCHER_TYPE* (name)

Optional EDR 49 fields

This list identifies the optional EDR record fields for a successful recharge from a periodic charge (EDR type 49):

- *NEW_ACCT_STATE* (always active - A)
- *NEW_ACCT_TYPE* (ID of account after recharge)
- *OLD_ACCT_STATE* (P or D before update)
- *OLD_ACCT_TYPE* (ID of account before recharge)
- *PC_TYPE* (periodic charge type)
- *PRO_RATE* (periodic charge subscription)
- *RELOAD_BONUS* (promotion name)
- *RELOAD_BONUS_AMOUNT* (amount applied)
- *RELOAD_BONUS_EXPIRY* (date remaining bonus expires)
- *RELOAD_BONUS_LEFT* (bonus amount remaining)

Periodic Charge Named Event Succeeds (EDR 49)

Mandatory EDR 49 fields

This list identifies the mandatory EDR record fields for a successful periodic charge for a named event (EDR type 49):

- *ACCOUNT_TYPE* (Product Type ID)
- *ACS_CUST_ID* (ACS Customer ID)
- *BALANCE_TYPES* (existing account)
- *BALANCES* (pre-transaction account balances)
- *CASCADE_ID* (balance type cascade IDs)
- *CHARGE_NAME* (of periodic charge)
- *COSTS* (rated calls)
- *CS* (call status, S or D) (call status, S or D)
- *DISCOUNTS* (for each named event)
- *EVENT_CLASS* (list of classes used)
- *EVENT_COST* (for each named event)
- *EVENT_COUNT* (for each named event)
- *EVENT_NAME* (list used for this call)
- *EVENT_TIME_COST* (for a named event)
- *TCS* (ccs time call started)
- *WALLET_TYPE* (ID of wallet changed)

Optional EDR 49 fields

This list identifies the optional EDR record fields for a successful periodic charge for a named event (EDR type 49):

- *NEW_ACCT_STATE* (always active - A)
- *OLD_ACCT_STATE* (P or D before update)
- *OVERDRAWN_AMOUNT* (take Balance Negative)
- *PC_TYPE* (periodic charge type)
- *PRO_RATE* (periodic charge subscription)
- *REMAINING_CHARGE* (partial Charge)

Periodic Charge Recharge Fails (EDR 49)

Mandatory EDR 49 fields

This list identifies the mandatory EDR record fields for an unsuccessful recharge using a periodic charge (EDR type 49):

- *ACCOUNT_TYPE* (Product Type ID)
- *ACS_CUST_ID* (ACS Customer ID)
- CS (call status, always D)
- *NACK* (short list of codes)
- *RESULT* (general cause)
- *WALLET_TYPE* (ID of wallet changed)

Periodic Charge Named Event Fails (EDR 49)

Mandatory EDR 49 fields

This list identifies the mandatory EDR record fields for an unsuccessful periodic charge for a named event (EDR type 49):

- *ACS_CUST_ID* (ACS Customer ID)
- CS (call status, always D)
- *EVENT_CLASS* (list of classes used)
- *EVENT_NAME* (list used for this call)
- *NACK* (short list of codes)
- *TCS* (ccs time call started)

Change Subscription State Succeeds (EDR 52)

Mandatory EDR 52 fields

This list identifies the mandatory EDR record fields for a successful periodic charge subscription state change (EDR type 52):

- *ACCOUNT_TYPE* (Product Type ID)
- *ACCT_ID* (changed wallet ID)
- *ACCT_REF_ID* (changed account ID)
- *BILLING_ENGINE_ID* (BE where account resides)
- *CHARGE_EXPIRY* (*new periodic charge expiry*) (new periodic charge expiry)
- *OLD_CHARGE_EXPIRY* (periodic charge expiry date changes)
- *CHARGE_NAME* (of periodic charge)
- *CLI* (for the account that will be changed)
- CS (*call status, S or D*) (call status, S or D)
- *NEW_CHARGE_STATE* (periodic charge subscription state)
- *OLD_CHARGE_STATE* (periodic charge subscription state)
- *RECORD_DATE* (date edr created)
- *WALLET_TYPE* (ID of wallet changed)

Optional EDR 52 fields

This list identifies the optional EDR record fields for a successful periodic charge subscription state change (EDR type 52):

- *SCP_ID* (where call originated)
- *SEQUENCE_NUMBER* (call identifier)

Change Subscription State Fails (EDR 52)

Mandatory EDR 52 fields

This list identifies the mandatory EDR record fields for a failed periodic charge subscription state change (EDR type 52):

- *ACCOUNT_TYPE* (Product Type ID)
- *ACCT_ID* (changed wallet ID)
- *ACCT_REF_ID* (changed account ID)
- *BILLING_ENGINE_ID* (BE where account resides)
- *CHARGE_EXPIRY* (*new periodic charge expiry*) (new periodic charge expiry)
- *OLD_CHARGE_EXPIRY* (periodic charge expiry date changes)
- *CHARGE_NAME* (of periodic charge)
- *CLI* (for the account that will be changed)
- CS (call status, always D)
- *NEW_CHARGE_STATE* (periodic charge subscription state)
- *OLD_CHARGE_STATE* (periodic charge subscription state)
- *RECORD_DATE* (date edr created)
- *WALLET_TYPE* (ID of wallet changed)

Optional EDR 52 fields

This list identifies the optional EDR record fields for a failed periodic charge subscription state change (EDR type 52):

- *NEW_CHARGE_STATE* (periodic charge subscription state)
- *OLD_CHARGE_STATE* (periodic charge subscription state)
- *CHARGE_EXPIRY* (*new periodic charge expiry*) (new periodic charge expiry)

13

Web Initiated Recharges

Overview

Introduction

This chapter defines the CCS EDRs for web initiated recharges.

Web Initiated Recharge Succeeds using PI (EDR 8)

Mandatory EDR 8 fields

The recharge succeeds where the REFERENCE field of the EDR record has a WS prefix indicating this is a recharge that was initiated through a web interface.

This list identifies the mandatory EDR record fields for a successful web initiated recharge using PI (EDR type 8):

- *ACCOUNT_TYPE* (Product Type ID)
- *ACS_CUST_ID* (ACS Customer ID)
- *BALANCES* (pre-transaction account balances)
- *BONUS_TYPE* (name)
- *COSTS* (rated calls)
- *CS* (*call status, S or D*) (call status, S or D)
- *NEW_BALANCE_EXPIRIES* (dates after voucher recharge)
- *OLD_BALANCE_EXPIRIES* (dates before voucher recharge)
- *PI* (logon name and IP address)
- *REFERENCE* (web site reference - ws)
- *RESULT* (web - success)
- *WALLET_TYPE* (ID of wallet recharged)

Optional EDR 8 fields

This list identifies the optional EDR record fields for a web recharge succeeds using PI (EDR type 8):

- *BEARER_TYPE* (*bearer type for promotions*) (bearer type for rewards)
- *CHANNEL* (*for rewards*) (for rewards)
- *NEW_ACCT_STATE* (after update)
- *OLD_ACCT_STATE* (before update)

Note: The NEW_ACCT_STATE and OLD_ACCT_STATE tags will always be present when the freeform recharge causes a change to the wallet state.

Example EDR 8 for web

```
ACCOUNT_TYPE=145|ACCT_ID=83938|ACCT_REF_ID=83200|ACS_CUST_ID=11|BALANCES=0|BALAN  
CE_TYPES=25|BILLING_ENGINE_ID=16|BONUS_TYPE=CUSTOM|CDR_TYPE=8|COSTS=-  
200000|CS=S|NEW_BALANCE_EXPIRIES=|OLD_BALANCE_EXPIRIES=|PI=sdgAT10.11.169.14|  
RECORD_DATE=20091102100721|REFERENCE=WS_Recharge|  
RESULT=Success|SCP_ID=265805204|SEQUENCE_NUMBER=144298|WALLET_TYPE=21
```

Note

The sequence of all fields output in an EDR is not guaranteed.

14

PI Promotional Recharges

Overview

Introduction

This chapter defines the CCS EDRs for Provisioning Interface (PI) promotional recharges.

PI Promotional Recharge Succeeds using PI (EDR 2)

Mandatory EDR 2 fields

This list identifies the mandatory EDR record fields for a successful PI promotional recharge using PI (EDR type 2):

- *ACS_CUST_ID* (ACS Customer ID)
- *BALANCE_TYPES* (existing account)
- *BALANCES* (pre-transaction account balances)
- *BUCKET_IDS* (within balance type recharged)
- *COSTS* (rated calls)
- *CS* (call status, S or D) (call status, S or D)
- *NEW_BALANCE_EXPIRIES* (dates after voucher recharge)
- *OLD_BALANCE_EXPIRIES* (dates before voucher recharge)
- *PI* (logon name and IP address)
- *REFERENCE* (from pi reference)
- *WALLET_TYPE* (ID of wallet recharged)

MSISDN additional fields

If the MSISDN ccsCDRLoader plug-in is installed on the SMS, the following field will be present:

- *MSISDN* (account calling number)

Example EDR 2 for pi promo

```
BILLING_ENGINE_ID=21|SCP_ID=161986004|SEQUENCE_NUMBER=12|CDR_TYPE=2|
RECORD_DATE=20040804141927|ACCT_ID=61|ACCT_REF_ID=61|ACS_CUST_ID=1|BALANCES=1000|
BALANCE_TYPES=1|BUCKET_IDS=45844|COSTS=-100|CS=S|NEW_BALANCE_EXPIRIES=|
OLD_BALANCE_EXPIRIES=|PI=adminAT192.168.25.106|REFERENCE=PI Promotional|WALLET_TYPE=1
```

Note

The sequence of all fields output in an EDR is not guaranteed.

15

Friends & Family, Friends & Destination Config Change

Overview

Introduction

This chapter defines the CCS EDRs for Friends & Family and Friends & Destination configuration changes.

F&F/F&D Change Succeeds using IVR (EDR 5)

Mandatory EDR 5 fields

This list identifies the mandatory EDR record fields for a successful F&F and F&D change using IVR (EDR type 5):

- *ACCOUNT_TYPE* (Product Type ID)
- *ACS_CUST_ID* (ACS Customer ID)
- *BALANCE_TYPES* (account changed or created)
- *BALANCES* (pre-transaction account balances)
- *CASCADE_ID* (balance type cascade IDs)
- *CS* (*call status, S or D*) (call status, S or D)
- *DISCOUNTS* (for each named event)
- *EVENT_CLASS* (list of classes used)
- *EVENT_COST* (for each named event)
- *EVENT_COUNT* (for each named event)
- *EVENT_NAME* (list used for this call)
- *EVENT_TIME_COST* (for a named event)
- *TCS* (ccs time call started)
- *WALLET_TYPE* (ID of wallet changed)

Optional EDR 5 fields

This list identifies the optional EDR record fields for a successful F&F, F&D configuration change (EDR type 5):

- *OVERDRAWN_AMOUNT* (take Balance Negative)
- *REMAINING_CHARGE* (partial Charge)

Account Activated additional fields

If the account is activated, the following fields are generated:

- *NEW_ACCT_STATE* (always active - A)
- *OLD_ACCT_STATE* (P or D before update)

MSISDN additional fields

If the MSISDN ccsCDRLoader plug-in is installed on the SMS, the following field will be present:

- *MSISDN* (account calling number)

Example EDR 5 for fnf

```
BILLING_ENGINE_ID=21|SCP_ID=230612513|SEQUENCE_NUMBER=488297|CDR_TYPE=5|
RECORD_DATE=20040803145823|ACCT_ID=61|ACCT_REF_ID=61|WALLET_TYPE=1|ACS_CUST_ID=1|CS=S|
TCS=20040706104957|BALANCE_TYPES=1|BALANCES=1000|COSTS=50|ACCOUNT_TYPE=4|EVENT_CLASS=FnF
FnD
Events|EVENT_NAME=FnF Config
Change|EVENT_TIME_COST=0.00|EVENT_COST=50|EVENT_COUNT=1|DISCOUNT=0|CASCADE=5
```

Note

The sequence of all fields output in an EDR is not guaranteed.

F&F/F&D Change Fails using IVR (EDR 5)

Mandatory EDR 5 fields

This list identifies the mandatory EDR record fields for an unsuccessful F&F and F&D change using IVR (EDR type 5):

- *ACS_CUST_ID* (ACS Customer ID)
- *CS* (call status, always D)
- *EVENT_CLASS* (list of classes used)
- *EVENT_NAME* (list used for this call)
- *NACK* (short list of codes)
- *TCS* (ccs time call started)

MSISDN additional fields

If the MSISDN ccsCDRLoader plug-in is installed on the SMS, the following field will be present:

- *MSISDN* (account calling number)

Example EDR 5 for fnf (Remove1)

```
BILLING_ENGINE_ID=21|SCP_ID=230612530|SEQUENCE_NUMBER=487291|CDR_TYPE=5|
RECORD_DATE=20070723084009|ACCT_ID=83|ACCT_REF_ID=83|EVENT_CLASS=FnF FnD Events|
EVENT_NAME=FnF Config Change| NACK=INSF|TCS=20040706104957|CS=D|ACS_CUST_ID=1
```

Note

The sequence of all fields output in an EDR is not guaranteed.

F&F/F&D Change Succeeds using PI (EDR 28)

Mandatory EDR 28 fields

This list identifies the mandatory EDR record fields for a successful F&F and F&D change using PI (EDR type 28):

- *ACS_CUST_ID* (ACS Customer ID)
- *CLI* (initiating call number)
- *NEW_ACTIVE_SVC* (account type)
- *NEW_FD* (friends destination number)
- *NEW_FF* (list of friends and family numbers)
- *OLD_ACTIVE_SVC* (account type)
- *OLD_FD* (friends destination number)
- *OLD_FF* (list of friends and family numbers)
- *PI* (logon name and IP address)
- *WALLET_TYPE* (ID of wallet recharged)

MSISDN additional fields

If the MSISDN ccsCDRLoader plug-in is installed on the SMS, the following field will be present:

- *MSISDN* (account calling number)

Example EDR 28 for fnf

```
BILLING_ENGINE_ID=1|SCP_ID=110537566|SEQUENCE_NUMBER=26|CDR_TYPE=28|
RECORD_DATE=20050111105223|PI-adminAT192.168.25.182|ACCT_ID=22|ACCT_REF_ID=22|
ACS_CUST_ID=1|CLI=1473111222|OLD_FF=488122346|,777777779|NEW_FF=488122346,777777776|
OLD_ACTIVE_SVC=D|NEW_ACTIVE_SVC=F|OLD_FD=44|NEW_FD=22|WALLET_TYPE=1
```

Note

The sequence of all fields output in an EDR is not guaranteed.

F&F/F&D Change Fails using PI (EDR 5)

Mandatory EDR 5 fields

This list identifies the mandatory EDR record fields for an unsuccessful F&F and F&D change using PI (EDR type 5):

- *ACCOUNT_TYPE* (Product Type ID)
- *ACS_CUST_ID* (ACS Customer ID)
- *CS* (call status, always D)
- *EVENT_CLASS* (list of classes used)
- *EVENT_NAME* (list used for this call)
- *NACK* (short list of codes)
- *TCE* (ccs time call ended)
- *WALLET_TYPE* (ID of wallet recharged)

MSISDN additional fields

If the MSISDN ccsCDRLoader plug-in is installed on the SMS, the following field will be present:

- *MSISDN* (account calling number)

Example EDR 5 for fnf (Remove2)

```
BILLING_ENGINE_ID=4|SCP_ID=161986004|SEQUENCE_NUMBER=10|CDR_TYPE=5|  
RECORD_DATE=20070810043324|ACCT_ID=1021|ACCT_REF_ID=1021|EVENT_CLASS=FnF FnD Events|  
EVENT_NAME=FnD Config Change|NACK=WDIS|TCS=20070810043324|CS=D|ACCOUNT_TYPE=41|  
PI=adminAT192.168.25.108|WALLET_TYPE=1|ACS_CUST_ID=1
```

Note

The sequence of all fields output in an EDR is not guaranteed.

F&F/F&D New Entry Succeeds using PI (EDR 5)

Mandatory EDR 5 fields

This list identifies the mandatory EDR record fields for a successful F&F and F&D new entry using PI (EDR type 5):

- *ACCOUNT_TYPE* (Product Type ID)
- *ACS_CUST_ID* (ACS Customer ID)
- *BALANCE_TYPES* (account changed or created)
- *BALANCES* (pre-call or account creation)
- *CASCADE_ID* (balance type cascade IDs)

- *COSTS* (rated calls)
- *CS* (*call status, S or D*) (call status, S or D)
- *DISCOUNTS* (for each named event)
- *EVENT_CLASS* (list of classes used)
- *EVENT_COST* (for each named event)
- *EVENT_COUNT* (for each named event)
- *EVENT_NAME* (list used for this call)
- *EVENT_TIME_COST* (for a named event)
- *PI* (logon name and IP address)
- *TCS* (ccs time call started)
- *WALLET_TYPE* (ID of wallet recharged)

Optional EDR 5 fields

This list identifies the optional EDR record fields for a successful F&F, F&D configuration change (EDR type 5):

- *OVERDRAWN_AMOUNT* (take Balance Negative)
- *REMAINING_CHARGE* (partial Charge)

MSISDN additional fields

If the MSISDN ccsCDRLoader plug-in is installed on the SMS, the following field will be present:

- *MSISDN* (account calling number)

Note

The sequence of all fields output in an EDR is not guaranteed.

16

Call Barring Config Change

Overview

Introduction

This chapter defines the CCS EDRs for call barring configuration changes.

Call Barring Change Succeeds using PI (EDR 30)

Mandatory EDR 30 fields

This list identifies the mandatory EDR record fields for a successful call barring change using PI (EDR type 30):

- *ACS_CUST_ID* (ACS Customer ID)
- *BARRED_LIST_TYPE* (description)
- *CLI* (initiating call number)
- *IGNORE_BARRED* (ignore numbers in call barring list)
- *NEW_BARRED_LIST* (of call barring numbers)
- *OLD_BARRED_LIST* (of call barring numbers)
- *PI* (logon name and IP address)
- *WALLET_TYPE* (ID of wallet recharged)

MSISDN additional fields

If the MSISDN ccsCDRLoader plug-in is installed on the SMS, the following field will be present:

- *MSISDN* (account calling number)

Example EDR 30 for call barring

```
BILING_ENGINE_ID=2|SCP_ID=110537566|SEQUENCE_NUMBER=1060|CDR_TYPE=30|
RECORD_DATE=20070809113017|ACCT_ID=1021|ACCT_REF_ID=102|PI=adminAT192.168.25.108|
ACS_CUST_ID=1|WALLET_TYPE=1|CLI=11012|OLD_BARRED_LIST=|
NEW_BARRED_LIST=03200000001,03200000002,03200000003,03200000004,03200000005|
BARRED_LIST_TYPE=ALLOWED
```

Note

The sequence of all fields output in an EDR is not guaranteed.

17

Change 'Disable Incoming Calls when Roaming' Flag

Overview

Introduction

This chapter defines the CCS EDRs for 'Disable Incoming Calls when Roaming' (DICWR) flag changes.

DICWR Flag Change Succeeds using Screens (EDR 29)

Mandatory EDR 29 fields

This list identifies the mandatory EDR record fields for a successful DICWR change using screens (EDR type 29):

- *ACCOUNT_TYPE* (Product Type ID)
- *ACS_CUST_ID* (ACS Customer ID)
- *CLI* (for the account that will be changed)
- *DICWR* (Disable Incoming Calls When Roaming)
- *USER* (operator logon name)
- *WALLET_TYPE* (ID of wallet recharged)

MSISDN additional fields

If the MSISDN ccsCDRLoader plug-in is installed on the SMS, the following field will be present:

- *MSISDN* (account calling number)

Example EDR 29-

```
BILLING_ENGINE_ID=0|SCP_ID=110537566|SEQUENCE_NUMBER=139450184|CDR_TYPE=29|
RECORD_DATE=20070704145441|ACCT_ID=61|ACCT_REF_ID=61|USER=SU|CLI=1234|ACS_CUST_ID=1|
WALLET_TYPE=1|DICWR=TRUE|ACCOUNT_TYPE=24
```

Note

The sequence of all fields output in an EDR is not guaranteed.

DICWR Flag Change Succeeds using PI (EDR 29)

Mandatory EDR 29 fields

This list identifies the mandatory EDR record fields for a successful DICWR change using PI (EDR type 29):

- *ACCOUNT_TYPE* (Product Type ID)
- *ACS_CUST_ID* (ACS Customer ID)
- *CLI* (for the account that will be changed)
- *DICWR* (Disable Incoming Calls When Roaming)
- *PI* (logon name and IP address)
- *WALLET_TYPE* (ID of wallet recharged)

Example EDR 29

```
BILLING_ENGINE_ID=2|SCP_ID=110537566|SEQUENCE_NUMBER=1061|CDR_TYPE=29|  
RECORD_DATE=20070809120324|ACCT_ID=1032|ACCT_REF_ID=1032|CLI=11023|ACS_CUST_ID=1|  
WALLET_TYPE=1|PI=adminat192.168.25.108|DICWR=TRUE|MSISDN=11023|ACCOUNT_TYPE=24
```

MSISDN additional fields

If the MSISDN ccsCDRLoader plug-in is installed on the SMS, the following field will be present:

- *MSISDN* (account calling number)

Note

The sequence of all fields output in an EDR is not guaranteed.

18

PI Adds Service Charge

Overview

Introduction

This chapter defines the CCS EDRs for Provisioning Interface (PI) adds service charges.

PI Adds Service Charges Succeeds using PI (EDR 2,5)

Mandatory EDR 2 fields CCSSC1

This EDR is produced when **CHARGE** or **REFUND** is specified in the PI command but not **EVENT**.

This list identifies the mandatory EDR record fields for a successful PI adds service charge using PI command CCSSC1 ADD (EDR type 2):

- *ACCOUNT_TYPE* (Product Type ID)
- *ACS_CUST_ID* (ACS Customer ID)
- *BALANCE_TYPES* (existing account)
- *BALANCES* (pre-transaction account balances)
- *COSTS* (rated calls)
- *NEW_ACCT_EXPIRY* (date after update)
- *NEW_ACCT_STATE* (after update)
- *NEW_BALANCE_EXPIRIES* (date after balance update)
- *OLD_ACCT_EXPIRY* (dates before update)
- *OLD_ACCT_STATE* (before update)
- *OLD_BALANCE_EXPIRIES* (dates before balance update)
- *PI* (logon name and IP address)
- *WALLET_TYPE* (ID of wallet recharged)

Optional EDR 2 fields CCSSC1

This list identifies the optional EDR record fields for a successful PI adds service charge using PI command CCSSC1 ADD (EDR type 2):

- *REFERENCE* (from pi reference)

Mandatory EDR 5 fields CCSSC1

This EDR is produced when **EVENT** or **CLASS** is specified in the PI command but not **CHARGE** or **REFUND**.

This list identifies the mandatory EDR record fields for a successful PI adds service charge using PI command CCSSC1 ADD (EDR type 5):

- *ACCOUNT_TYPE* (Product Type ID)
- *CS* (*call status, S or D*) (call status, S or D)
- *TCS* (ccs time call started)
- *WALLET_TYPE* (ID of wallet changed)

Optional EDR 5 fields CCSSC1

This EDR is produced when **EVENT** or **CLASS** is specified in the PI command but not **CHARGE** or **REFUND**.

This list identifies the optional EDR record fields for a successful PI adds service charge using PI command CCSSC1 ADD (EDR type 5):

- *NEW_ACCT_STATE* (after update)
- *OLD_ACCT_STATE* (before update)
- *REFERENCE* (from pi reference)
- *OVERDRAWN_AMOUNT* (take Balance Negative)
- *REMAINING_CHARGE* (partial Charge)

Mandatory EDR 5 fields CCSSC1

This EDR is produced when **CHARGE** or **REFUND** is specified, and also **EVENT** is specified in the PI command.

This list identifies the mandatory EDR record fields for a successful PI adds service charge using PI command CCSSC1 ADD (EDR type 5):

- *ACCOUNT_TYPE* (Product Type ID)
- *ACS_CUST_ID* (ACS Customer ID)
- *BALANCE_TYPES* (existing account)
- *BALANCES* (pre-transaction account balances)
- *CASCADE* (always empty for pi)
- *COSTS* (rated calls)
- *CS* (*call status, S or D*) (call status, S or D)
- *DISCOUNT* (always zero for pi)
- *EVENT_CLASS* (list of classes used)
- *EVENT_COST* (for each named event)
- *EVENT_COUNT* (for each named event)
- *EVENT_NAME* (list used for this call)

- *NEW_ACCT_EXPIRY* (date after update)
- *NEW_ACCT_STATE* (after update)
- *NEW_BALANCE_EXPIRIES* (date after balance update)
- *OLD_ACCT_EXPIRY* (dates before update)
- *OLD_ACCT_STATE* (before update)
- *OLD_BALANCE_EXPIRIES* (dates before balance update)
- *PI* (logon name and IP address)
- *TCS* (ccs time call started)
- *WALLET_TYPE* (ID of wallet recharged)

Optional EDR 5 fields CCSSC1

This EDR is produced when **CHARGE** or **REFUND** is specified, and also **EVENT** is specified in the PI command.

This list identifies the optional EDR record fields for a successful PI adds service charge using PI command CCSSC1 ADD (EDR type 5):

- *REFERENCE* (from pi reference)
- *OVERDRAWN_AMOUNT* (take Balance Negative)
- *REMAINING_CHARGE* (partial Charge)

Mandatory EDR 2 fields CCSSC2

This list identifies the mandatory EDR record fields for a successful PI adds service charge using PI command CCSSC2 ADD (EDR type 2):

- *ACCOUNT_TYPE* (Product Type ID)
- *ACS_CUST_ID* (ACS Customer ID)
- *BALANCE_TYPES* (account changed or created)
- *BALANCES* (pre-call or account creation)
- *CASCADE_ID* (balance type cascade IDs)
- *CLI* (initiating call number)
- *COSTS* (rated calls)
- *CS* (*call status, S or D*) (call status, S or D)
- *DISCOUNT_TYPE* - one of:
 - *DISCOUNT_TYPE* (applied to this call)
 - *DISCOUNT_TYPE* (applied to this call) - R*W
- *DISCOUNTS* (rated calls)
- *DURATION* (call length)
- *FCA* (final call address)
- *LENGTHS* - one of:
 - *LENGTHS* (rate durations)

- *LENGTHS* (rate durations) -1end duration
- *MAX_CHARGE* (for this call)
- *RATES* (rated calls)
- *TCE* (ccs time call ended)
- *TCS* (ccs time call started)
- *TN* (ccs called number)
- *WALLET_TYPE* (ID of wallet changed)

Mandatory EDR 2 fields CTLSC1

This EDR is produced when **CHARGE** or **REFUND** is specified in the PI command but not **EVENT**.

This list identifies the mandatory EDR record fields for a successful PI adds service charge using PI command CTLSC1 ADD (EDR type 2):

- *ACCOUNT_TYPE* (Product Type ID)
- *ACS_CUST_ID* (ACS Customer ID)
- *BALANCE_TYPES* (existing account)
- *BALANCES* (pre-transaction account balances)
- *COSTS* (rated calls)
- *NEW_ACCT_EXPIRY* (date after update)
- *NEW_ACCT_STATE* (after update)
- *NEW_BALANCE_EXPIRIES* (date after balance update)
- *OLD_ACCT_EXPIRY* (dates before update)
- *OLD_ACCT_STATE* (before update)
- *OLD_BALANCE_EXPIRIES* (dates before balance update)
- *PI* (logon name and IP address)
- *WALLET_TYPE* (ID of wallet recharged)

Mandatory EDR 5 fields CTLSC1

This EDR is produced when **EVENT** or **CLASS** is specified in the PI command but not **CHARGE** or **REFUND**.

This list identifies the mandatory EDR record fields for a successful PI adds service charge using PI command CTLSC1 ADD (EDR type 5):

- *ACCOUNT_TYPE* (Product Type ID)
- *CS* (*call status, S or D*) (call status, S or D)
- *TCS* (ccs time call started)
- *WALLET_TYPE* (ID of wallet changed)

Optional EDR 5 fields CTLSC1

This EDR is produced when **EVENT** or **CLASS** is specified in the PI command but not **CHARGE** or **REFUND**.

This list identifies the optional EDR record fields for a successful PI adds service charge using PI command CTLSC1 ADD (EDR type 5):

- *NEW_ACCT_STATE* (after update)
- *OLD_ACCT_STATE* (before update)
- *OVERDRAWN_AMOUNT* (take Balance Negative)
- *REMAINING_CHARGE* (partial Charge)

Mandatory EDR 5 fields CTLSC1

This EDR is produced when **CHARGE** or **REFUND** is specified, and also **EVENT** is specified in the PI command.

This list identifies the mandatory EDR record fields for a successful PI adds service charge using PI command CTLSC1 ADD (EDR type 5):

- *ACCOUNT_TYPE* (Product Type ID)
- *ACS_CUST_ID* (ACS Customer ID)
- *BALANCE_TYPES* (existing account)
- *BALANCES* (pre-transaction account balances)
- *CASCADE* (always empty for pi)
- *COSTS* (rated calls)
- *CS* (call status, always S)
- *DISCOUNT* (always zero for pi)
- *EVENT_CLASS* (list of classes used)
- *EVENT_COST* (for each named event)
- *EVENT_COUNT* (for each named event)
- *EVENT_NAME* (list used for this call)
- *NEW_ACCT_EXPIRY* (date after update)
- *NEW_ACCT_STATE* (after update)
- *NEW_BALANCE_EXPIRIES* (date after balance update)
- *OLD_ACCT_EXPIRY* (dates before update)
- *OLD_ACCT_STATE* (before update)
- *OLD_BALANCE_EXPIRIES* (dates before balance update)
- *PI* (logon name and IP address)
- *TCS* (ccs time call started)
- *WALLET_TYPE* (ID of wallet recharged)

Optional EDR 5 fields CTLSC1

This EDR is produced when **CHARGE** or **REFUND** is specified, and also **EVENT** is specified in the PI command.

This list identifies the optional EDR record fields for a successful PI adds service charge using PI command CTLSC1 ADD (EDR type 5):

- *OVERDRAWN_AMOUNT* (take Balance Negative)
- *REMAINING_CHARGE* (partial Charge)

Mandatory EDR 2 fields CTLSC2

This list identifies the mandatory EDR record fields for a successful PI adds service charge using PI command CTLSC2 ADD (EDR type 2):

- *ACCOUNT_TYPE* (Product Type ID)
- *ACS_CUST_ID* (ACS Customer ID)
- *BALANCE_TYPES* (account changed or created)
- *BALANCES* (pre-call or account creation)
- *CASCADE_ID* (balance type cascade IDs)
- *CLI* (initiating call number)
- *COSTS* (rated calls)
- *CS* (*call status, S or D*) (call status, S or D)
- *DISCOUNT_TYPE* - one of:
 - *DISCOUNT_TYPE* (applied to this call)
 - *DISCOUNT_TYPE* (applied to this call) - R*W
- *DISCOUNTS* (rated calls)
- *DURATION* (call length)
- *FCA* (final call address)
- *LENGTHS* - one of:
 - *LENGTHS* (rate durations)
 - *LENGTHS* (rate durations) -1end duration
- *MAX_CHARGE* (for this call)
- *RATES* (rated calls)
- *TCE* (ccs time call ended)
- *TCS* (ccs time call started)
- *TN* (ccs called number)
- *WALLET_TYPE* (ID of wallet changed)

Mandatory EDR 2 fields CTLSC2

This list identifies the mandatory EDR record fields for a successful PI adds service charge using PI command CTLSC2 ADD (EDR type 2):

- *ACCOUNT_TYPE* (Product Type ID)
- *ACS_CUST_ID* (ACS Customer ID)
- *BALANCE_TYPES* (account changed or created)
- *BALANCES* (pre-call or account creation)
- *CASCADE_ID* (balance type cascade IDs)
- *CLI* (initiating call number)
- *COSTS* (rated calls)
- *CS* (call status, S or D) (call status, S or D)
- *DISCOUNT_TYPE* - one of:
 - *DISCOUNT_TYPE* (applied to this call)
 - *DISCOUNT_TYPE* (applied to this call) - R*W
 - *DISCOUNTS* (rated calls)
- *DURATION* (call length)
- *FCA* (final call address)
- *LENGTHS* - one of:
 - *LENGTHS* (rate durations)
 - *LENGTHS* (rate durations) -1end duration
- *MAX_CHARGE* (for this call)
- *RATES* (rated calls)
- *TCE* (ccs time call ended)
- *TCS* (ccs time call started)
- *TN* (ccs called number)
- *WALLET_TYPE* (ID of wallet changed)

MSISDN additional fields

If the MSISDN ccsCDRLoader plug-in is installed on the SMS, the following field will be present:

- *MSISDN* (account calling number)

MSISDN example

```
BILLING_ENGINE_ID=21|SCP_ID=110537566|SEQUENCE_NUMBER=139450184|CDR_TYPE=2|
RECORD_DATE=20040803122626|ACCT_ID=83|ACCT_REF_ID=83|USER=SU||ACCOUNT_TYPE=1|
PI=adminAT192.168.25.106|OLD_ACCT_EXPIRY=0|NEW_ACCT_EXPIRY=0|MAX_CONCURRENT=1|COMMENT=|
BALANCE_TYPES=1|BALANCES=0|COSTS=10|OLD_BALANCE_EXPIRIES=20050310143044|
NEW_BALANCE_EXPIRIES=20050310143044|ACS_CUST_ID=1|WALLET_TYPE=1|
```

```
EVENT_CLASS=ProductType | EVENT_NAME=ProductTypeSwap | EVENT_COST=100 | EVENT_COUNT=1 |  
DISCOUNT=0 | CASCADE=0 | MSISDN=1394111111
```

Note

The sequence of all fields output in an EDR is not guaranteed.

19

Product Type Swap

Overview

Introduction

This chapter defines the CCS EDRs for product types swaps (PTS).

PTS Succeeds using Screens (EDR type 31)

Mandatory EDR 31 fields

There is no associated cost for the PTS that succeeds using the screens.

This list identifies the mandatory EDR record fields for a successful PTS using screens (EDR type 31):

- *ACCOUNT_TYPE* (Product Type ID)
- *ACS_CUST_ID* (ACS Customer ID)
- *CLI* (for the account that will be changed)
- *NEW_ACCT_TYPE* (prod type swap)
- *OLD_ACCT_TYPE* (prod type swap)
- *USER* (operator logon name)

MSISDN additional fields

If the MSISDN ccsCDRLoader plug-in is installed on the SMS, the following field will be present:

- *MSISDN* (account calling number)

Example EDR 31 (Remove1)

```
BILLING_ENGINE_ID=0|SCP_ID=110537566|SEQUENCE_NUMBER=139450184|CDR_TYPE=31|  
RECORD_DATE=20070704150023|ACCT_ID=61|ACCT_REF_ID=61|ACCOUNT_TYPE=24|CLI=1234|  
OLD_ACCT_TYPE=oracle_pt|NEW_ACCT_TYPE=test_pt|USER=SU|ACS_CUST_ID=1
```

Note

The sequence of all fields output in an EDR is not guaranteed.

PTS Succeeds using PI (EDR type 31)

Mandatory EDR 31 fields

There is no associated cost for the PTS that succeeds using PI.

This list identifies the mandatory EDR record fields for a successful PTS using PI (EDR type 31):

- *ACCOUNT_TYPE* (Product Type ID)
- *ACS_CUST_ID* (ACS Customer ID)
- *CLI* (for the account that will be changed)
- *NEW_ACCT_TYPE* (prod type swap)
- *OLD_ACCT_TYPE* (prod type swap)
- *USER* (operator logon name)

MSISDN additional fields

If the MSISDN ccsCDRLoader plug-in is installed on the SMS, the following field will be present:

- *MSISDN* (account calling number)

Example EDR 31

```
BILLING_ENGINE_ID=0|SCP_ID=110537566|SEQUENCE_NUMBER=139450184|CDR_TYPE=31|  
RECORD_DATE=20040804150023|ACCT_ID=61|ACCT_REF_ID=61|CLI=1234|ACCOUNT_TYPE=11|  
OLD_ACCT_TYPE=oracle_pt|NEW_ACCT_TYPE=test_pt|USER=SU|ACS_CUST_ID=1|MSISDN=1234
```

Note

The sequence of all fields output in an EDR is not guaranteed.

PTS Succeeds using the GUI (EDR 31, 32)

Introduction

There is an associated cost for the PTS that succeeds using the GUI.

There are 2 EDR records created for this event - a EDR of type 31 and a EDR of type 32.

Mandatory EDR 31 fields

This list identifies the mandatory EDR record fields for a successful PTS using the GUI (EDR type 31):

- *ACS_CUST_ID* (ACS Customer ID)
- *CLI* (for the account that will be changed)
- *NEW_ACCT_TYPE* (prod type swap)

- *OLD_ACCT_TYPE* (prod type swap)
- *USER* (operator logon name)

Mandatory EDR 32 fields

This list identifies the mandatory EDR record fields for a successful PTS using the GUI (EDR type 32):

- *ACCOUNT_TYPE* (Product Type ID)
- *ACS_CUST_ID* (ACS Customer ID)
- *BALANCE_TYPES* (account changed or created)
- *BALANCES* (pre-call or account creation)
- *CASCADE_ID* (balance type cascade IDs)
- *COSTS* (rated calls)
- *CS* (*call status, S or D*) (call status, S or D)
- *DISCOUNTS* (for each named event)
- *EVENT_CLASS* (list of classes used)
- *EVENT_COST* (for each named event)
- *EVENT_COUNT* (for each named event)
- *EVENT_NAME* (list used for this call)
- *EVENT_TIME_COST* (for a named event)
- *TCS* (ccs time call started)
- *TERMINAL* (Network ID)
- *USER* (operator logon name)

Optional EDR 32 fields

This list identifies the optional EDR record fields for a successful PTS using the GUI (EDR type 32):

- *OVERDRAWN_AMOUNT* (take Balance Negative)
- *REMAINING_CHARGE* (partial Charge)

Account Activated additional fields

If the account is activated, the following fields will be present:

- *NEW_ACCT_STATE* (always active - A)
- *OLD_ACCT_STATE* (pre-call)

MSISDN additional fields

If the MSISDN ccsCDRLoader plug-in is installed on the SMS, the following field will be present:

- *MSISDN* (account calling number)

Example EDR 31 (Remove2)

```
BILLING_ENGINE_ID=0|SCP_ID=110537566|SEQUENCE_NUMBER=139450184|CDR_TYPE=31|
RECORD_DATE=20040804150023|ACCT_ID=61|ACCT_REF_ID=61|CLI=1234|OLD_ACCT_TYPE=test_pt|
NEW_ACCT_TYPE=oracle_pt|USER=SU|ACS_CUST_ID=1
```

Example EDR 32

```
BILLING_ENGINE_ID=21|SCP_ID=110537566|SEQUENCE_NUMBER=139450184|CDR_TYPE=32|
RECORD_DATE=20070704150312|ACCT_ID=61|ACCT_REF_ID=61|USER=SU|TERMINAL=192.168.25.108|
ACS_CUST_ID=1|CS=S|TCS=20070704150312|BALANCE_TYPES=1|BALANCES=1000|COSTS=100|
ACCOUNT_TYPE=2|EVENT_CLASS=Product Type|EVENT_NAME=Product Type Swap|EVENT_COST=100|
EVENT_COUNT=1|EVENT_TIME_COST=0:00|DISCOUNT=0|CASCADE=1
```

Account activated example

```
BILLING_ENGINE_ID=21|SCP_ID=110537566|SEQUENCE_NUMBER=139450184|CDR_TYPE=32|
RECORD_DATE=20040804150312|ACCT_ID=61|ACCT_REF_ID=61|USER=SU|ACS_CUST_ID=1|CS=S|
TCS=20040804150312|BALANCE_TYPES=1|BALANCES=1000|COSTS=100|ACCOUNT_TYPE=2|
EVENT_CLASS=Product Type|EVENT_NAME=Product Type Swap|EVENT_COST=100|EVENT_COUNT=1|
EVENT_TIME_COST=0:00|DISCOUNT=0|CASCADE=0|OLD_ACCT_STATE=P|NEW_ACCT_STATE=A
```

Example Account Activated - MSISDN

```
BILLING_ENGINE_ID=21|SCP_ID=110537566|SEQUENCE_NUMBER=139450184|CDR_TYPE=32|
RECORD_DATE=20040804150312|ACCT_ID=61|ACCT_REF_ID=61|USER=SU|ACS_CUST_ID=1|CS=S|
TCS=20040804150312|BALANCE_TYPES=1|BALANCES=1000|COSTS=100|ACCOUNT_TYPE=2|
EVENT_CLASS=Product Type|EVENT_NAME=Product Type Swap|EVENT_COST=100|EVENT_COUNT=1|
DISCOUNT=0|CASCADE=0|OLD_ACCT_STATE=P|NEW_ACCT_STATE=A|MSISDN=1394111111
```

Note

The sequence of all fields output in an EDR is not guaranteed.

PTS Succeeds using IVR (EDR 31, 32)

Introduction

There may or may not be an associated cost for the PTS that succeeds using the IVR as a 100% discount may be applied.

There are 2 EDR records created for this event - a EDR of type 31 and a EDR of type 32.

Mandatory EDR 31 fields

This list identifies the mandatory EDR record fields for a successful PTS using IVR (EDR type 31):

- *ACS_CUST_ID* (ACS Customer ID)
- *CLI* (for the account that will be changed)
- *NEW_ACCT_TYPE* (prod type swap)
- *OLD_ACCT_TYPE* (prod type swap)

- *USER* (operator logon name)

Mandatory EDR 32 fields

This list identifies the mandatory EDR record fields for a successful PTS using IVR (EDR type 32):

- *ACCOUNT_TYPE* (Product Type ID)
- *ACS_CUST_ID* (ACS Customer ID)
- *BALANCE_TYPES* (account changed or created)
- *BALANCES* (pre-call or account creation)
- *CASCADE_ID* (balance type cascade IDs)
- *COSTS* (rated calls)
- *CS* (*call status, S or D*) (call status, S or D)
- *DISCOUNTS* (for each named event)
- *EVENT_CLASS* (list of classes used)
- *EVENT_COST* (for each named event)
- *EVENT_COUNT* (for each named event)
- *EVENT_NAME* (list used for this call)
- *EVENT_TIME_COST* (for a named event)
- *NEW_ACCT_TYPE* (prod type swap)
- *TCS* (ccs time call started)
- *WALLET_TYPE* (ID of wallet changed)

Optional EDR 32 fields

This list identifies the optional EDR record fields for a successful PTS using IVR (EDR type 32):

- *OVERDRAWN_AMOUNT* (take Balance Negative)
- *REMAINING_CHARGE* (partial Charge)

Account Activated additional fields

If the account is activated, the following fields will be present:

- *NEW_ACCT_STATE* (always active - A)
- *OLD_ACCT_STATE* (pre-call)

MSISDN additional fields

If the MSISDN ccsCDRLoader plug-in is installed on the SMS, the following field will be present:

- *MSISDN* (account calling number)

Example EDR 31 (Remove3)

```
BILLING_ENGINE_ID=0|SCP_ID=110537566|SEQUENCE_NUMBER=139450184|CDR_TYPE=31|
RECORD_DATE=20040804150023|ACCT_ID=61|ACCT_REF_ID=61|CLI=1234|OLD_ACCT_TYPE=oracle_pt|
NEW_ACCT_TYPE=test_pt|USER=OP$SMF_OPER|ACS_CUST_ID=1
```

Example EDR 32 (Remove2)

```
BILLING_ENGINE_ID=21|SCP_ID=366273322|SEQUENCE_NUMBER=489322|CDR_TYPE=32|
RECORD_DATE=20040804150312|ACCT_ID=61|ACCT_REF_ID=61|USER=SU|ACS_CUST_ID=1|CS=S|
TCS=20040804150312|BALANCE_TYPES=1|BALANCES=1000|COSTS=100|ACCOUNT_TYPE=2|
EVENT_CLASS=Product Type|EVENT_NAME=Product Type Swap|EVENT_COST=100|EVENT_COUNT=1|
EVENT_TIME_COST=0:00|DISCOUNT=0|CASCADE=0
```

Account activated example

```
BILLING_ENGINE_ID=21|SCP_ID=366273322|SEQUENCE_NUMBER=489322|CDR_TYPE=32|
RECORD_DATE=20040804150312|ACCT_ID=61|ACCT_REF_ID=61|USER=SU|ACS_CUST_ID=1|CS=S|
TCS=20040804150312|BALANCE_TYPES=1|BALANCES=1000|COSTS=100|ACCOUNT_TYPE=2|
EVENT_CLASS=Product Type|EVENT_NAME=Product Type Swap|EVENT_COST=100|EVENT_COUNT=1|
EVENT_TIME_COST=0:00|DISCOUNT=0|CASCADE=0|OLD_ACCT_STATE=P|NEW_ACCT_STATE=A
```

Example MSISDN

```
BILLING_ENGINE_ID=21|SCP_ID=366273322|SEQUENCE_NUMBER=489322|CDR_TYPE=32|
RECORD_DATE=20040804150312|ACCT_ID=61|ACCT_REF_ID=61|USER=SU|ACS_CUST_ID=1|CS=S|
TCS=20040804150312|BALANCE_TYPES=1|BALANCES=1000|COSTS=100|ACCOUNT_TYPE=2|
EVENT_CLASS=Product Type|EVENT_NAME=Product Type Swap|EVENT_COST=100|EVENT_COUNT=1|
DISCOUNT=0|CASCADE=0|OLD_ACCT_STATE=P|NEW_ACCT_STATE=A|MSISDN=1394111111
```

Note

The sequence of all fields output in an EDR is not guaranteed.

PTS Fails using the GUI (EDR 32)

Mandatory EDR 32 fields

This list identifies the mandatory EDR record fields for an unsuccessful product type swap (PTS) using the SMS UI. (EDR type 32):

- *ACCOUNT_TYPE* (Product Type ID)
- *ACS_CUST_ID* (ACS Customer ID)
- *CS* (call status, always D)
- *EVENT_CLASS* (list of classes used)
- *EVENT_NAME* (list used for this call)
- *NACK* (short list of codes)
- *TCS* (ccs time call started)
- *TERMINAL* (Network ID)

- *USER* (operator logon name)

MSISDN additional fields

If the MSISDN ccsCDRLoader plug-in is installed on the SMS, the following field will be present:

- *MSISDN* (account calling number)

Example EDR 32 (Remove91)

```
BILLING_ENGINE_ID=21|SCP_ID=110537566|SEQUENCE_NUMBER=139450184|CDR_TYPE=32|
RECORD_DATE=20070718105233|ACCT_ID=2082|ACCT_REF_ID=2082|EVENT_CLASS=Product Type|
EVENT_NAME=Product Type Swap|NACK=NENA|TCS=20070718105233|CS=D|ACCOUNT_TYPE=41|USER=SU|
TERMINAL=192.168.25.108|ACS_CUST_ID=1
```

Example MSISDN

```
BILLING_ENGINE_ID=21|SCP_ID=230612530|SEQUENCE_NUMBER=487291|CDR_TYPE=32|
RECORD_DATE=20040803121758|ACCT_ID=83|ACCT_REF_ID=83|EVENT_CLASS=Product Type|
EVENT_NAME=Product Type Swap|NACK=INSF|TCS=20040706104957|CS=D|ACCOUNT_TYPE=1|
WALLET_TYPE=1|NEW_ACCT_TYPE=2|ACS_CUST_ID=1|MSISDN=1394111111
```

Note

The sequence of all fields output in an EDR is not guaranteed.

PTS Fails using IVR (EDR 32)

Mandatory EDR 32 fields

This list identifies the mandatory EDR record fields for an unsuccessful PTS using IVR. (EDR type 32):

- *ACCOUNT_TYPE* (Product Type ID)
- *ACS_CUST_ID* (ACS Customer ID)
- *CS* (call status, always D)
- *EVENT_CLASS* (list of classes used)
- *EVENT_NAME* (list used for this call)
- *NEW_ACCT_TYPE* (prod type swap)
- *TCS* (ccs time call started)

MSISDN additional fields

If the MSISDN ccsCDRLoader plug-in is installed on the SMS, the following field will be present:

- *MSISDN* (account calling number)

Example EDR 32 (Remove5)

```
BILLING_ENGINE_ID=21|SCP_ID=230612530|SEQUENCE_NUMBER=487291|CDR_TYPE=32|  
RECORD_DATE=20040803121758|ACCT_ID=83|ACCT_REF_ID=83|EVENT_CLASS=Product Type|  
EVENT_NAME=Product Type Swap|NACK=INSF|TCS=20040706104957|CS=D|ACCOUNT_TYPE=1|  
NEW_ACCT_TYPE=2|ACS_CUST_ID=1
```

Example MSISDN

```
BILLING_ENGINE_ID=21|SCP_ID=230612530|SEQUENCE_NUMBER=487291|CDR_TYPE=32|  
RECORD_DATE=20040803121758|ACCT_ID=83|ACCT_REF_ID=83|EVENT_CLASS=Product Type|  
EVENT_NAME=Product Type Swap|NACK=INSF|TCS=20040706104957|CS=D|ACCOUNT_TYPE=1|  
WALLET_TYPE=1|NEW_ACCT_TYPE=2|ACS_CUST_ID=1|MSISDN=1394111111
```

Note

The sequence of all fields output in an EDR is not guaranteed.

20

Read Secret Code

Overview

Introduction

This chapter defines the CCS EDRs for read secret code changes.

Read Secret Code Change Fails using IVR (EDR 33)

Mandatory EDR 33 fields

This list identifies the mandatory EDR record fields for an unsuccessful read secret code using IVR (EDR type 33):

- *ACS_CUST_ID* (ACS Customer ID)
- *BAD_PINS* (number of attempts)

Optional EDR 33 fields

This list identifies the optional EDR record fields for an unsuccessful read secret code using IVR (EDR type 33):

- *NEW_ACCT_STATE* (always frozen - F)
- *OLD_ACCT_STATE* (always active - A)

MSISDN additional fields

If the MSISDN ccsCDRLoader plug-in is installed on the SMS, the following field will be present:

- *MSISDN* (account calling number)

Example EDR 33 (Remove1)

```
BILLING_ENGINE_ID=21 | SCP_ID=366273322 | SEQUENCE_NUMBER=488298 | CDR_TYPE=33 |  
RECORD_DATE=20040803145823 | ACCT_ID=61 | ACCT_REF_ID=61 | BAD_PINS=1 | ACS_CUST_ID=1
```

Note

The sequence of all fields output in an EDR is not guaranteed.

21

Expiration

Overview

Introduction

This chapter defines the CCS EDRs for expiries.

Note: If the `ACCT_REF_ID` header field for an expiry EDR is set to zero (0), this indicates that the change was not limited to a single account but was applied to the wallet or balance of all the referenced accounts.

Balance Expiry (EDR 3)

Mandatory EDR 3 fields

This list identifies the mandatory EDR record fields for balance expiry (EDR type 3):

- `ACCOUNT_TYPE` (Product Type ID)
- `BALANCE_TYPES` (account changed or created)
- `BALANCES` (pre-transaction account balances)
- `COSTS` (rated calls)

Optional EDR 3 fields

This list identifies the optional EDR record fields for balance expiry (EDR type 3):

- `EXPIRED_WALLET` (ID of expired wallet)
- `NEW_ACCT_STATE` (after update)
- `OLD_ACCT_STATE` (before update)
- `OLD_BALANCE_EXPIRIES` (dates before balance update)

MSISDN additional fields

If the MSISDN `ccsCDRLoader` plug-in is installed on the SMS, the following field will be present:

- `MSISDN` (account calling number)

Example EDR 3 (Remove1)

```
BILLING_ENGINE_ID=21 | SCP_ID=0 | SEQUENCE_NUMBER=0 | CDR_TYPE=3 | RECORD_DATE=20040803145823 |  
ACCT_ID=61 | ACCT_REF_ID=61 | BALANCES=5100 | BALANCE_TYPES=1 | COSTS=5100 | ACCOUNT_TYPE=1
```

Example MSISDN

```
BILLING_ENGINE_ID=21 | SCP_ID=0 | SEQUENCE_NUMBER=0 | CDR_TYPE=3 | RECORD_DATE=20040803145823 |
ACCT_ID=61 | ACCT_REF_ID=61 | BALANCES=5100 | BALANCE_TYPES=1 | COSTS=5100 |
EXPIRIES=20040731212949 | ACCOUNT_TYPE=1 | MSISDN=1394111111
```

Note

The sequence of all fields output in an EDR is not guaranteed.

Account Expiry (EDR 3)

Mandatory EDR 3 fields

This list identifies the mandatory EDR record fields for account expiry (EDR type 3):

- *ACCOUNT_TYPE* (Product Type ID)
- *ACS_CUST_ID* (ACS Customer ID)
- *NEW_ACCT_STATE* (always terminated - T)
- *OLD_ACCT_EXPIRY* (dates before update)
- *OLD_ACCT_STATE* (always active - A)

Optional EDR 3 fields

This list identifies the optional EDR record fields for account expiry (EDR type 3):

- *OLD_BALANCE_EXPIRIES* (dates before balance update)

MSISDN additional fields

If the MSISDN ccsCDRLoader plug-in is installed on the SMS, the following field will be present:

- *MSISDN* (account calling number)

Example EDR 3 (Remove91)

```
BILLING_ENGINE_ID=21 | SCP_ID=0 | SEQUENCE_NUMBER=0 | CDR_TYPE=3 | RECORD_DATE=20040803145823 |
ACCT_ID=61 | ACCT_REF_ID=61 | NEW_ACCT_STATE=T | OLD_ACCT_STATE=A | ACS_CUST_ID=1 | ACCOUNT_TYPE=1
```

Example MSISDN

```
BILLING_ENGINE_ID=21 | SCP_ID=0 | SEQUENCE_NUMBER=0 | CDR_TYPE=3 | RECORD_DATE=20040803145823 |
ACCT_ID=61 | ACCT_REF_ID=61 | NEW_ACCT_STATE=T | OLD_ACCT_STATE=A | ACS_CUST_ID=1 |
OLD_ACCT_EXPIRY=20040731212949 | ACCOUNT_TYPE=1 | MSISDN=1394111111
```

Note

The sequence of all fields output in an EDR is not guaranteed.

PI Delete (EDR 2)

Mandatory EDR 2 fields

This list identifies the mandatory EDR record fields for PI delete (EDR type 2):

- *ACCOUNT_TYPE* (Product Type ID)
- *ACS_CUST_ID* (ACS Customer ID)
- *ACTIVATION_DATE* (account activation date)
- *BALANCE_TYPES* (account changed or created)
- *BALANCES* (pre-transaction account balances)
- *COSTS* (rated calls)
- *MAX_CONCURRENT* (maximum concurrent accesses allowed)
- *NEW_ACCT_EXPIRY* (date after update)
- *NEW_BALANCE_EXPIRIES* (date after balance update)
- *OLD_ACCT_EXPIRY* (dates before update)
- *OLD_ACCT_STATE* (always active - A)
- *OLD_BALANCE_EXPIRIES* (dates before balance update)
- *PI* (logon name and IP address)
- *WALLET_DELETED* (always success - Y)
- *WALLET_TYPE* (ID of wallet changed)

MSISDN additional fields

If the MSISDN ccsCDRLoader plug-in is installed on the SMS, the following field will be present:

- *MSISDN* (account calling number)

Note

The sequence of all fields output in an EDR is not guaranteed.

22

Roaming Voice Calls

Overview

Introduction

This chapter defines the CCS EDRs for roaming voice calls.

Successful Roaming Call (EDR type 1)

Introduction

For the purposes of this document, a roaming voice call is one of the following:

- CAMEL Originating
- Mobile Terminating
- USSD Callback

Depending on the software installed, a roaming voice call may result in either a EDR of type 1 or a EDR of type 11.

A EDR of type 11 will be created through modifying the original EDR type using a `ccsCDRLoaderPlugin` on the SMS. The `ccsCDRLoaderPlugin` may also modify the CLI and TN fields of the EDR record and add additional fields into the resulting EDR - details regarding these changes have been included in this section of the document.

Mandatory EDR 1 fields

This list identifies the mandatory EDR record fields for a successful roaming call (EDR type 1):

- *ACCOUNT_TYPE* (Product Type ID)
- *ACS_CUST_ID* (ACS Customer ID)
- *BALANCE_TYPES* (account changed or created)
- *BALANCES* (pre-transaction account balances)
- *CASCADE_ID* (balance type cascade IDs)
- *CLI*(initiating call number)
- *DISCOUNT_TYPE* - one of:
 - *DISCOUNT_TYPE* (applied to this call)
 - *DISCOUNT_TYPE* (applied to this call) - R*W
- *DISCOUNTS* (rated calls)
- *DURATION* (call length)

- *DURATION_CHARGED*
- *END_CALL_REASON* (reasons for call termination)
- *FCA* (final call address)
- *LENGTHS* - one of:
 - *LENGTHS* (rate durations)
 - *LENGTHS* (rate durations) -1end duration
- *MAX_CHARGE* (for this call)
- *RATES* (rated calls)
- *TCE* (ccs time call ended)
- *TCS* (ccs time call started)
- *TN* (ccs called number)
- *WALLET_TYPE* (ID of wallet changed)

Optional EDR 1 fields

This list identifies the optional EDR record fields for a successful roaming call (EDR type 1):

- *CUG_NAME* (closed user group)
- *OVERRIDDEN_TARIFF_PLAN* (ID)
- *RELC* (inap release cause)
- *TARIFF_CODE* (name)

Partial EDR additional fields

Enabling of Mid-Session EDRs production creates Partial EDRs. Either the Commit Volume Threshold or Mid-Session EDRs parameters are enabled (**Rating Management > Reservation Config > New Reservation Config** screen).

These additional tags are on all the partial EDRs, but not on the final, complete EDR:

- *MID_SESSION* (partial EDR)
- *SESSION_SEQUENCE* (partial EDR)

Timed-out reservation confirmation additional fields

If a confirmed reservation times out, these tags will be added to the EDR.

- *RNCF* (Reservation Not Charged For)
- *TIMED_OUT* (reservation confirmation)

Account Activated additional fields

If the account is activated, the following fields will be present:

- *NEW_ACCT_STATE* (always active - A)
- *OLD_ACCT_STATE* (pre-call)

Cross balance type discount additional fields

If the cross balance type discounting has been applied during the call, the following fields will be present:

- *CBTD_BALANCE_TYPES* (list to apply to discounts)
- *CBTD_BALANCE_TYPES* (list to apply to discounts) - mid call rate changes
- *CBTD_BALANCES* (value for each cross balance type)
- *CBTD_BALANCES* (value for each cross balance type) - mid call rate change
- *CBTD_CASCADE_ID* (used for this call)
- *CBTD_CASCADE_ID* (used for this call) - mid call rate change
- *CBTD_COSTS* (costs applied to each cross balance type)
- *CBTD_COSTS* (costs applied to each cross balance type) - mid call rate changes
- *CBTD_DISCOUNTS* (discounts applied to balance types)
- *CBTD_DISCOUNTS* (discounts applied to balance types) - mid call rate changes

MSISDN additional fields

If the MSISDN ccsCDRLoader plug-in is installed on the SMS, the following field will be present:

- *MSISDN* (account calling number)

Example EDR 1 (Remove8)

```
BILLING_ENGINE_ID=21 | SCP_ID=366273322 | SEQUENCE_NUMBER=487291 | CDR_TYPE=1 |
RECORD_DATE=20040803142342 | ACCT_ID=83 | ACCT_REF_ID=83 | CLI=01206233252 | ACS_CUST_ID=1 |
BALANCE_TYPES=1 | BALANCES=1000 | COSTS=28 | ACCOUNT_TYPE=1 | CASCADE_ID=1 | RATES=50, 25 |
LENGTHS=120.00, 40.00 | DISCOUNTS=450000, 560000 | MAX_CHARGE=500 | DURATION=160 |
DURATION_CHARGED=160 | TN=01473289900 | TCS=20040803141934 | TCE=20040803142034 | CS=S |
DISCOUNT_TYPE=S*W*R | END_CALL_REASON=14
```

Example Account Activated

```
BILLING_ENGINE_ID=21 | SCP_ID=366273322 | SEQUENCE_NUMBER=487291 | CDR_TYPE=1 |
RECORD_DATE=20040803142342 | ACCT_ID=83 | ACCT_REF_ID=83 | CLI=01206233252 | ACS_CUST_ID=1 |
BALANCE_TYPES=1 | BALANCES=1000 | COSTS=28 | ACCOUNT_TYPE=1 | CASCADE_ID=1 | RATES=50, 25 |
LENGTHS=120.00, 0.00 | DISCOUNTS=450000, 560000 | MAX_CHARGE=500 | DURATION=60 |
DURATION_CHARGED=60 | TN=01473289900 | TCS=20040803141934 | TCE=20040803142034 | CS=S |
DISCOUNT_TYPE=S*W*R | OLD_ACCT_STATE=P | NEW_ACCT_STATE=A | END_CALL_REASON=15
```

Example MSISDN

```
BILLING_ENGINE_ID=21 | SCP_ID=366273322 | SEQUENCE_NUMBER=487291 | CDR_TYPE=1 |
RECORD_DATE=20040803142342 | ACCT_ID=83 | ACCT_REF_ID=83 | CLI=1234 | ACS_CUST_ID=1 |
BALANCE_TYPES=1 | BALANCES=1000 | COSTS=28 | ACCOUNT_TYPE=1 | CASCADE_ID=1 | RATES=50, 25 |
LENGTHS=120.00, 0.00 | DISCOUNTS=450000, 560000 | MAX_CHARGE=500 | DURATION=60 |
DURATION_CHARGED=60 | TN=01473289900 | TCS=20040803141934 | TCE=20040803142034 | CS=S |
DISCOUNT_TYPE=S*W*R | OLD_ACCT_STATE=P | NEW_ACCT_STATE=A | MSISDN=1234 | END_CALL_REASON=15
```

Note

The sequence of all fields output in an EDR is not guaranteed.

Declined Roaming Call (EDR type 1)

Introduction

For the purposes of this document, a roaming voice call is one of the following:

- CAMEL Originating
- Mobile Terminating
- USSD Callback

Depending on the software installed, a roaming voice call may result in either a EDR of type 1 or a EDR of type 11.

A EDR of type 11 will be created through modifying the original EDR type using a `ccsCDRLoaderPlugin` on the SMS. The `ccsCDRLoaderPlugin` may also modify the CLI and TN fields of the EDR record and add additional fields into the resulting EDR - details regarding these changes have been included in this section of the document.

Mandatory EDR 1 fields

This list identifies the mandatory EDR record fields for an unsuccessful roaming call (EDR type 1):

- `ACCOUNT_TYPE` (Product Type ID)
- `ACS_CUST_ID` (ACS Customer ID)
- `CLI` (initiating call number)
- `CS` (call status, always D)
- `END_CALL_REASON` (*reasons for call termination*)
- `NACK` (long list of codes)
- `TCS` (ccs time call started)
- `TN` (ccs called number)
- `WALLET_TYPE` (ID of wallet changed)

Optional EDR 1 fields

This list identifies the optional EDR record fields for an unsuccessful roaming call (EDR type 1):

- `CUG_NAME` (closed user group)

Account Activated additional fields

If the account is activated, the following fields will be present:

- `NEW_ACCT_STATE` (always active - A)

- *OLD_ACCT_STATE* (pre-call)

MSISDN additional fields

If the MSISDN ccsCDRLoader plug-in is installed on the SMS, the following field will be present:

- *MSISDN* (account calling number)

Mobile number portability additional fields

If the Mobile Number Portability (MNP) software is installed, the following fields will be present:

- *PORTED* (name of porting carrier)

Example EDR 1 (Remove9)

```
BILLING_ENGINE_ID=21 | SCP_ID=230612530 | SEQUENCE_NUMBER=487291 | CDR_TYPE=1 |
RECORD_DATE=20040803121758 | ACCT_ID=83 | ACCT_REF_ID=83 | CLI=1234 | TN=01473289900 |
TCS=20040625124332 | CS=D | NACK=INSF | ACS_CUST_ID=1 | ACCOUNT_TYPE=1 | END_CALL_REASON=11
```

Example Account Activated

```
BILLING_ENGINE_ID=21 | SCP_ID=230612530 | SEQUENCE_NUMBER=487291 | CDR_TYPE=1 |
RECORD_DATE=20040803121758 | ACCT_ID=83 | ACCT_REF_ID=83 | CLI=1234 | TN=01473289900 |
TCS=20040625124332 | CS=D | NACK=INSF | ACS_CUST_ID=1 | OLD_ACCT_STATE=P | NEW_ACCT_STATE=A |
ACCOUNT_TYPE=1 | END_CALL_REASON=11
```

Example MSISDN

```
BILLING_ENGINE_ID=21 | SCP_ID=230612530 | SEQUENCE_NUMBER=487291 | CDR_TYPE=1 |
RECORD_DATE=20040803121758 | ACCT_ID=83 | ACCT_REF_ID=83 | CLI=1234 | TN=01473289900 |
TCS=20040625124332 | CS=D | NACK=INSF | ACS_CUST_ID=1 | OLD_ACCT_STATE=P | NEW_ACCT_STATE=A |
ACCOUNT_TYPE=1 | MSISDN=1234 | END_CALL_REASON=11
```

Note

The sequence of all fields output in an EDR is not guaranteed.

Successful Roaming Call (EDR type 11)

Introduction

For the purposes of this document, a roaming voice call is one of the following:

- CAMEL Originating
- Mobile Terminating
- USSD Callback

Depending on the software installed, a roaming voice call may result in either a EDR of type 1 or a EDR of type 11.

A EDR of type 11 will be created through modifying the original EDR type using a ccsCDRLoaderPlugin on the SMS. The ccsCDRLoaderPlugin may also modify the CLI and TN

fields of the EDR record and add additional fields into the resulting EDR - details regarding these changes have been included in this section of the document.

Mandatory EDR 11 fields

This list identifies the optional EDR record fields for a successful roaming call (EDR type 11):

- *ACCOUNT_TYPE* (Product Type ID)
- *ACS_CUST_ID* (ACS Customer ID)
- *BALANCE_TYPES* (account changed or created)
- *BALANCES* (pre-transaction account balances)
- *CASCADE_ID* (balance type cascade IDs)
- *CLI* (roaming initiating call number)
- *COSTS* (rated calls)
- *CS* (*call status, S or D*) (call status, S or D)
- *DISCOUNT_TYPE* - one of:
 - *DISCOUNT_TYPE* (applied to this call)
 - *DISCOUNT_TYPE* (applied to this call) - R*W
- *DISCOUNTS* (rated calls)
- *DURATION* (call length)
- *FCA* (final call address)
- *LENGTHS* - one of:
 - *LENGTHS* (rate durations)
 - *LENGTHS* (rate durations) -1end duration
- *MAX_CHARGE* (for this call)
- *RATES* (rated calls)
- *ROAMING_COUNTRY* (name)
- *ROAMING_TYPE* (of call)
- *TCE* (ccs time call ended)
- *TCS* (ccs time call started)
- *TN* (roaming called number)
- *WALLET_TYPE* (ID of wallet changed)

Optional EDR 11 fields

This list identifies the optional EDR record fields for a successful roaming call (EDR type 11):

- *CUG_NAME* (closed user group)
- *OVERRIDDEN_TARIFF_PLAN* (ID)
- *RELC* (inap release cause)
- *TARIFF_CODE* (name)

Partial EDR additional fields

Enabling of Mid-Session EDRs production creates Partial EDRs. Either the Commit Volume Threshold or Mid-Session EDRs parameters are enabled (**Rating Management > Reservation Config > New Reservation Config** screen).

These additional tags are on all the partial EDRs, but not on the final, complete EDR:

- *MID_SESSION* (partial EDR)
- *SESSION_SEQUENCE* (partial EDR)

Timed-out reservation confirmation additional fields

If a confirmed reservation times out, these tags will be added to the EDR.

- *RNCF* (Reservation Not Charged For)
- *TIMED_OUT* (reservation confirmation)

Account Activated additional fields

If the account is activated, the following fields will be present:

- *NEW_ACCT_STATE* (always active - A)
- *OLD_ACCT_STATE* (pre-call)

Cross balance type discount additional fields

If the cross balance type discounting has been applied during the call, the following fields will be present:

- *CBTD_BALANCE_TYPES* (list to apply to discounts)
- *CBTD_BALANCE_TYPES* (list to apply to discounts) - mid call rate changes
- *CBTD_BALANCES* (value for each cross balance type)
- *CBTD_BALANCES* (value for each cross balance type) - mid call rate change
- *CBTD_CASCADE_ID* (used for this call)
- *CBTD_CASCADE_ID* (used for this call) - mid call rate change
- *CBTD_COSTS* (costs applied to each cross balance type)
- *CBTD_COSTS* (costs applied to each cross balance type) - mid call rate changes
- *CBTD_DISCOUNTS* (discounts applied to balance types)
- *CBTD_DISCOUNTS* (discounts applied to balance types) - mid call rate changes

MSISDN additional fields

If the MSISDN ccsCDRLoader plug-in is installed on the SMS, the following field will be present:

- *MSISDN* (account calling number)

Mobile number portability additional fields

If the Mobile Number Portability (MNP) software is installed, the following fields will be present:

- *PORTED* (name of porting carrier)

Example EDR 11 (Remove1)

```
BILLING_ENGINE_ID=21|SCP_ID=366273322|SEQUENCE_NUMBER=487291|CDR_TYPE=11|  
RECORD_DATE=20040803142342|ACCT_ID=83|ACCT_REF_ID=83|CLI=016505550185|ACS_CUST_ID=1|  
BALANCE_TYPES=1|BALANCES=1000|COSTS=28|ACCOUNT_TYPE=1|CASCADE_ID=1|RATES=50,25|  
LENGTHS=120,0.0|DISCOUNTS=450000,560000|MAX_CHARGE=500|DURATION=60|TN=016505550100|  
TCS=20040803141934|TCE=20040803142034|CS=S|DISCOUNT_TYPE=S*W*R|ROAMING_TYPE=MT|  
ROAMING_COUNTRY=United Kingdom
```

Note

The sequence of all fields output in an EDR is not guaranteed.

Declined Roaming Call (EDR type 11)

Introduction

For the purposes of this document, a roaming voice call is one of the following:

- CAMEL Originating
- Mobile Terminating
- USSD Callback

Depending on the software installed, a roaming voice call may result in either a EDR of type 1 or a EDR of type 11.

A EDR of type 11 will be created through modifying the original EDR type using a `ccsCDRLoaderPlugin` on the SMS. The `ccsCDRLoaderPlugin` may also modify the CLI and TN fields of the EDR record and add additional fields into the resulting EDR - details regarding these changes have been included in this section of the document.

Mandatory EDR 11 fields

This list identifies the optional EDR record fields for an unsuccessful roaming call (EDR type 11):

- *ACS_CUST_ID* (ACS Customer ID)
- *CS* (call status, always D)
- *CLI* (roaming initiating call number)
- *NACK* (long list of codes)
- *ROAMING_COUNTRY* (name)
- *ROAMING_TYPE* (of call)
- *TCS* (ccs time call started)
- *TN* (roaming called number)

Optional EDR 11 fields

This list identifies the optional EDR record fields for an unsuccessful roaming call (EDR type 11):

- *CUG_NAME* (closed user group)

Account Activated additional fields

If the account is activated, the following fields will be present:

- *NEW_ACCT_STATE* (always active - A)
- *OLD_ACCT_STATE* (pre-call)

Mobile number portability additional fields

If the Mobile Number Portability (MNP) software is installed, the following fields will be present:

- *PORTED* (name of porting carrier)

MSISDN additional fields

If the MSISDN ccsCDRLoader plug-in is installed on the SMS, the following field will be present:

- *MSISDN* (account calling number)

Example EDR 11

```
BILLING_ENGINE_ID=21|SCP_ID=230612530|SEQUENCE_NUMBER=487291|CDR_TYPE=11|  
RECORD_DATE=20040803121758|ACCT_ID=83|ACCT_REF_ID=83|CLI=016505550185|TN=016505550100|  
TCS=20040625124332|CS=D|NACK=INSF|ACS_CUST_ID=1|ROAMING_TYPE=MT|ROAMING_COUNTRY=United  
Kingdom
```

Note

The sequence of all fields output in an EDR is not guaranteed.

23

Data and Video Calls (EDRs 50 and 51)

Overview

Introduction

This chapter describes the CCS EDRs types 50 and 51.

About Type 50 and 51 EDRs

Type 50 and 51 EDRs are based on type 1 EDRs by default. For a list of the fields output by type 1 EDRs, see *Voice Calls*. You can override the default EDR type for type 50, and type 51 EDRs, by specifying a different EDR type on the **Capability** tab in the Service Management window in the CCS user interface (UI). The fields output will depend on the EDR type for the triggered scenario. For more information on setting the override EDR type, see the discussion on service management in *CCS User's Guide*.

You can also customize the fields that are output by type 50 and type 51 EDRs by using the Set BE EDR feature node in your control plans; for example, you can add a new field to the EDR or change the value of an existing field. For more information about the Set BE EDR feature node, see *Feature Nodes Reference Guide*.

24

Prepaid Data

Overview

Introduction

This chapter defines the CCS EDRs for prepaid charges.

GPRS Content Charge Succeeds (EDR 5)

Mandatory EDR 5 fields

This list identifies the mandatory EDR record fields for a successful GPRS content charge (EDR type 5):

- *ACCOUNT_TYPE* (Product Type ID)
- *ACS_CUST_ID* (ACS Customer ID)
- *BALANCE_TYPES* (account changed or created)
- *BALANCES* (pre-transaction account balances)
- *CASCADE_ID* (balance type cascade IDs)
- *COSTS* (rated calls)
- *CS* (*call status, S or D*) (call status, S or D)
- *DISCOUNTS* (for each named event)
- *EVENT_CLASS* (list of classes used)
- *EVENT_COST* (for each named event)
- *EVENT_COUNT* (for each named event)
- *EVENT_NAME* (list used for this call)
- *EVENT_TIME_COST* (for a named event)
- *TCS* (ccs time call started)

Optional EDR 5 fields

This list identifies the optional EDR record fields for a successful GPRS content charge (EDR type 5):

- *OVERDRAWN_AMOUNT* (take Balance Negative)
- *REMAINING_CHARGE* (partial Charge)

Account Activated additional fields

If the account is activated, the following fields will be present:

- *NEW_ACCT_STATE* (always active - A)
- *OLD_ACCT_STATE* (pre-call)

Example EDR 5 (Remove3)

```
BILLING_ENGINE_ID=21 | SCP_ID=230612530 | SEQUENCE_NUMBER=488297 | CDR_TYPE=5 |
RECORD_DATE=20040803145823 | ACCT_ID=61 | ACCT_REF_ID=61 | ACS_CUST_ID=1 | CS=S |
TCS=20040706104957 | BALANCE_TYPES=1 | BALANCES=1000 | COSTS=90 | ACCOUNT_TYPE=4 |
EVENT_CLASS=PrePaidData | EVENT_NAME=PPD_Content_10 | EVENT_COST=10 | EVENT_COUNT=9 | DISCOUNT=0 |
CASCADE=0
```

Note

The sequence of all fields output in an EDR is not guaranteed.

GPRS Content Charge Fails (EDR 5)

Mandatory EDR 5 fields

This list identifies the mandatory EDR record fields for an unsuccessful GPRS content charge (EDR type 5):

- *ACS_CUST_ID* (ACS Customer ID)
- *BALANCE_TYPES* (account changed or created)
- *BALANCES* (pre-transaction account balances)
- *CASCADE_ID* (balance type cascade IDs)
- *COSTS* (rated calls)
- *CS* (call status, always D)
- *DISCOUNTS* (for each named event)
- *EVENT_CLASS* (list of classes used)
- *EVENT_COST* (for each named event)
- *EVENT_COUNT* (for each named event)
- *EVENT_NAME* (list used for this call)
- *EVENT_TIME_COST* (for a named event)
- *NACK* (short list of codes)
- *TCS* (ccs time call started)

Example EDR 5 (Remove4)

```
BILLING_ENGINE_ID=21 | SCP_ID=230612530 | SEQUENCE_NUMBER=487291 | CDR_TYPE=5 |
RECORD_DATE=20040803121758 | ACCT_ID=83 | ACCT_REF_ID=83 | EVENT_CLASS=PrePaidData |
EVENT_NAME=PPD_Content_10 | NACK=INSF | TCS=20040706104957 | CS=D | ACS_CUST_ID=1
```

Note

The sequence of all fields output in an EDR is not guaranteed.

GPRS Volume or Duration Charge Succeeds (EDR 14)

Mandatory EDR 14 fields

This list identifies the mandatory EDR record fields for a successful GPRS volume or duration charge (EDR type 14):

- *ACCOUNT_TYPE* (Product Type ID)
- *ACS_CUST_ID* (ACS Customer ID)
- *BALANCE_TYPES* (account changed or created)
- *BALANCES* (pre-call or account creation)
- *CASCADE_ID* (balance type cascade IDs)
- *CLI* (initiating call number)
- *COSTS* (rated calls)
- *CS* (call status, S or D) (call status, S or D)
- *CUG_NAME* (closed user group)
- *DISCOUNTS* (for each named event)
- *EVENT_CLASS* (list of classes used)
- *EVENT_COST* (for each named event)
- *EVENT_COUNT* (for each named event)
- *EVENT_NAME* (list used for this call)
- *OVERRIDDEN_TARIFF_PLAN* (ID)
- *TARIFF_CODE* (name)
- *TCS* (ccs time call started)

Account Activated additional fields

If the account is activated, the following fields will be present:

- *NEW_ACCT_STATE* (always active - A)
- *OLD_ACCT_STATE* (pre-call)

Example EDR 14

```
BILLING_ENGINE_ID=21 | SCP_ID=230612530 | SEQUENCE_NUMBER=488297 | CDR_TYPE=14 |
RECORD_DATE=20040803145823 | ACCT_ID=61 | ACCT_REF_ID=61 | CLI=016505550185 | ACS_CUST_ID=1 | CS=S |
TCS=20040706104957 | BALANCE_TYPES=1 | BALANCES=1000 | COSTS=150 | ACCOUNT_TYPE=4 |
EVENT_CLASS=PrePaidData | EVENT_NAME=PPD_Volume_1 | EVENT_COST=1 | EVENT_COUNT=150 | DISCOUNT=0 |
CASCADE=0
```

Note

The sequence of all fields output in an EDR is not guaranteed.

GPRS Volume or Duration Charge Fails (EDR 5)

Mandatory EDR 5 fields

This list identifies the mandatory EDR record fields for an unsuccessful GPRS volume or duration charge (EDR type 5):

- *ACS_CUST_ID* (ACS Customer ID)
- *BALANCE_TYPES* (account changed or created)
- *BALANCES* (pre-transaction account balances)
- *CASCADE_ID* (balance type cascade IDs)
- *COSTS* (rated calls)
- *CS* (call status, always D)
- *CUG_NAME* (closed user group)
- *DISCOUNTS* (for each named event)
- *EVENT_CLASS* (list of classes used)
- *EVENT_COST* (for each named event)
- *EVENT_COUNT* (for each named event)
- *EVENT_NAME* (list used for this call)
- *EVENT_TIME_COST* (for a named event)
- *NACK* (short list of codes)
- *OVERRIDDEN_TARIFF_PLAN* (ID)
- *TARIFF_CODE* (name)
- *TCS* (ccs time call started)

Example EDR 5 (Remove3)

```
BILLING_ENGINE_ID=21 | SCP_ID=230612530 | SEQUENCE_NUMBER=487291 | CDR_TYPE=5 |  
RECORD_DATE=20040803121758 | ACCT_ID=83 | ACCT_REF_ID=83 | EVENT_CLASS=PrePaidData |  
EVENT_NAME=PPD_Volume_1 | NACK=INSF | TCS=20040706104957 | CS=D | ACS_CUST_ID=1
```

Note

The sequence of all fields output in an EDR is not guaranteed.

25

SMS-MO

Overview

Introduction

This chapter defines the CCS EDRs for SMS-MO messages.

In this chapter

This chapter contains the following topics.

- [National SMS-MO Succeeds \(EDR 12,13\)](#) 2
- [National SMS-MO Fails \(EDR 1, 5,12,13\)](#) 2
- [Roaming SMS-MO Succeeds \(EDR 12,13\)](#) 2
- [Roaming SMS-MO Fails \(EDR 1,5,12,13\)](#) 2

National SMS-MO Succeeds (EDR 12,13)

Introduction

There are two EDR records created for this event - a EDR type 12 and a EDR type 13.

Mandatory EDR 12 fields

This list identifies the mandatory EDR record fields for a successful national SMS-MO (EDR type 12):

- *ACCOUNT_TYPE* (Product Type ID)
- *ACS_CUST_ID* (ACS Customer ID)
- *BALANCE_TYPES* (account changed or created)
- *BALANCES* (pre-call or account creation)
- *CASCADE_ID* (balance type cascade IDs)
- *CLI* (initiating call number)
- *COSTS* (rated calls)
- *CS* (*call status, S or D*) (call status, S or D)
- *DISCOUNTS* (rated calls)
- *EVENT_CLASS* (list of classes used)
- *EVENT_COST* (for each named event)
- *EVENT_COUNT* (for each named event)

- *EVENT_NAME* (list used for this call)
- *EVENT_TIME_COST* (for a named event)
- *LOCADD* (additional configuration prefixes)
- *TCS* (ccs time call started)
- *TN* (ccs called number)
- *WALLET_TYPE* (ID of wallet recharged)

Optional EDR 12 fields

This list identifies the optional EDR record fields for a successful national SMS-MO (EDR type 12):

- *OVERRIDDEN_TARIFF_PLAN* (ID)
- *OVERDRAWN_AMOUNT* (take Balance Negative)
- *REMAINING_CHARGE* (partial Charge)
- *TARIFF_CODE* (name)

Mandatory EDR 13 fields

This list identifies the mandatory EDR record fields for a successful national SMS-MO (EDR type 13):

- *ACCOUNT_TYPE* (Product Type ID)
- *ACS_CUST_ID* (ACS Customer ID)
- *BALANCE_TYPES* (account changed or created)
- *BALANCES* (pre-call or account creation)
- *CASCADE_ID* (balance type cascade IDs)
- *CLI* (initiating call number)
- *COSTS* (rated calls)
- *CS* (call status, S or D) (call status, S or D)
- *DISCOUNT_TYPE* - one of:
 - *DISCOUNT_TYPE* (applied to this call)
 - *DISCOUNT_TYPE* (applied to this call) - R*W
- *DISCOUNTS* (rated calls)
- *DURATION* (call length)
- *LENGTHS* - one of:
 - *LENGTHS* (rate durations)
 - *LENGTHS* (rate durations) -1end duration
- *RATES* (rated calls)
- *TCE* (ccs time call ended)
- *TCS* (ccs time call started)
- *TN* (ccs called number)

- *WALLET_TYPE* (ID of wallet changed)

Optional EDR 13 fields

This list identifies the optional EDR record fields for a successful national SMS-MO (EDR type 13):

- *OVERRIDDEN_TARIFF_PLAN* (ID)
- *TARIFF_CODE* (name)

Account Activated additional fields

If the account is activated, the following fields will be present:

- *NEW_ACCT_STATE* (always active - A)
- *OLD_ACCT_STATE* (pre-call)

Cross balance type discount additional fields

If the cross balance type discounting has been applied during the call, the following fields will be present:

- *CBTD_BALANCE_TYPES* (list to apply to discounts)
- *CBTD_BALANCE_TYPES* (list to apply to discounts) - mid call rate changes
- *CBTD_BALANCES* (value for each cross balance type)
- *CBTD_BALANCES* (value for each cross balance type) - mid call rate change
- *CBTD_CASCADE_ID* (used for this call)
- *CBTD_CASCADE_ID* (used for this call) - mid call rate change
- *CBTD_COSTS* (costs applied to each cross balance type)
- *CBTD_COSTS* (costs applied to each cross balance type) - mid call rate changes
- *CBTD_DISCOUNTS* (discounts applied to balance types)
- *CBTD_DISCOUNTS* (discounts applied to balance types) - mid call rate changes

Mobile number portability additional fields

If the Mobile Number Portability (MNP) software is installed, the following fields will be present:

- *PORTED* (name of porting carrier)

MSISDN additional fields

If the MSISDN ccsCDRLoader plug-in is installed on the SMS, the following field will be present:

- *MSISDN* (account calling number)

Example EDR 12 (Remove10)

```
BILLING_ENGINE_ID=21 | SCP_ID=230612530 | SEQUENCE_NUMBER=488297 | CDR_TYPE=12 |
RECORD_DATE=20040803145823 | ACCT_ID=61 | ACCT_REF_ID=61 | WALLET_TYPE=1 | CLI=016505550185 |
```

```
TN=016505550100|LOCADD=E771231473289900|ACS_CUST_ID=1|CS=S|TCS=20040706104957|
BALANCE_TYPES=1|BALANCES=1000|COSTS=100|ACCOUNT_TYPE=4|EVENT_CLASS=SMSMO|
EVENT_NAME=SMSMO_100|EVENT_COST=100|EVENT_COUNT=1|DISCOUNT=0|CASCADE=0
```

Example Account Activated

```
BILLING_ENGINE_ID=21|SCP_ID=230612530|SEQUENCE_NUMBER=488297|CDR_TYPE=12|
RECORD_DATE=20040803145823|ACCT_ID=61|ACCT_REF_ID=61|WALLET_TYPE=1|CLI=016505550185|
TN=016505550100|LOCADD=E771231473289900|ACS_CUST_ID=1|CS=S|TCS=20040706104957|
BALANCE_TYPES=1|BALANCES=1000|COSTS=100|ACCOUNT_TYPE=4|EVENT_CLASS=SMSMO|
EVENT_NAME=SMSMO_100|EVENT_TIME_COST=0.00|EVENT_COST=100|EVENT_COUNT=1|DISCOUNT=0|
CASCADE=0|OLD_ACCT_STATE=P|NEW_ACCT_STATE=A
```

Example MSISDN

```
BILLING_ENGINE_ID=21|SCP_ID=230612530|SEQUENCE_NUMBER=488297|CDR_TYPE=12|
RECORD_DATE=20040803145823|ACCT_ID=61|ACCT_REF_ID=61|WALLET_TYPE=1|CLI=016505550185|
TN=016505550100|LOCADD=E771231473289900|ACS_CUST_ID=1|CS=S|TCS=20040706104957|
BALANCE_TYPES=1|BALANCES=1000|COSTS=100|ACCOUNT_TYPE=4|EVENT_CLASS=SMSMO|
EVENT_NAME=SMSMO_100|EVENT_COST=100|EVENT_COUNT=1|DISCOUNT=0|CASCADE=0|OLD_ACCT_STATE=P|
NEW_ACCT_STATE=A|MSISDN=016505550185
```

Note

The sequence of all fields output in an EDR is not guaranteed.

National SMS-MO Fails (EDR 1, 5,12,13)

Introduction

There are 4 EDR records created for a failed national SMS-MO - EDR types 1, 5, 12 or 13.

Mandatory EDR 1 and 13 fields

This list identifies the mandatory EDR record fields for an unsuccessful national SMS-MO (EDR type 1 or type 13):

- *ACCOUNT_TYPE* (Product Type ID)
- *ACS_CUST_ID* (ACS Customer ID)
- *CLI* (initiating call number)
- *CS* (call status, always D)
- *LOCADD* (additional configuration prefixes)
- *NACK* (short list of codes)
- *TCS* (ccs time call started)
- *TN* (ccs called number)
- *WALLET_TYPE* (ID of wallet changed)

Mandatory EDR 5 and 12 fields

This list identifies the mandatory EDR record fields for an unsuccessful national SMS-MO (EDR type 5 or type 12):

- *ACCOUNT_TYPE* (Product Type ID)
- *ACS_CUST_ID* (ACS Customer ID)
- *CLI* (initiating call number)
- *CS* (call status, always D)
- *EVENT_CLASS* (list of classes used)
- *EVENT_NAME* (list used for this call)
- *LOCADD* (additional configuration prefixes)
- *NACK* (short list of codes)
- *TCS* (ccs time call started)
- *TN* (ccs called number)

Account Activated additional fields

If the account is activated, the following fields will be present:

- *NEW_ACCT_STATE* (always active - A)
- *OLD_ACCT_STATE* (pre-call)

Mobile number portability additional fields

If the Mobile Number Portability (MNP) software is installed, the following fields will be present:

- *PORTED* (name of porting carrier)

MSISDN additional fields

If the MSISDN ccsCDRLoader plug-in is installed on the SMS, the following field will be present:

- *MSISDN* (account calling number)

Example EDR 5 (Remove10)

```
BILLING_ENGINE_ID=21 | SCP_ID=230612530 | SEQUENCE_NUMBER=487291 | CDR_TYPE=5 |
RECORD_DATE=20040803121758 | ACCT_ID=83 | ACCT_REF_ID=83 | BALANCE_TYPER=1 | BALANCES=500 |
EVENT_CLASS=SMSMO | EVENT_NAME=SMSMO_100 | NACK=INSF | TCS=20040706104957 | CS=D | ACS_CUST_ID=1 |
ACCOUNT_TYPE=1
```

Example MSISDN

```
BILLING_ENGINE_ID=21 | SCP_ID=230612530 | SEQUENCE_NUMBER=487291 | CDR_TYPE=5 |
RECORD_DATE=20040803121758 | ACCT_ID=83 | ACCT_REF_ID=83 | EVENT_CLASS=SMSMO |
EVENT_NAME=SMSMO_100 | NACK=INSF | TCS=20040706104957 | CS=D | ACS_CUST_ID=1 | ACCOUNT_TYPE=1 |
MSISDN=1394111111
```

Note

The sequence of all fields output in an EDR is not guaranteed.

Roaming SMS-MO Succeeds (EDR 12,13)

Introduction

There are 2 EDR records created for a successful roaming SMS-MO - a type 12 and a type 13.

Mandatory EDR 12 fields

This list identifies the mandatory EDR record fields for a successful national SMS-MO (EDR type 12):

- *ACCOUNT_TYPE* (Product Type ID)
- *ACS_CUST_ID* (ACS Customer ID)
- *BALANCE_TYPES* (account changed or created)
- *BALANCES* (pre-call or account creation)
- *CASCADE_ID* (balance type cascade IDs)
- *CLI* (initiating call number)
- *COSTS* (rated calls)
- *CS* (call status, S or D) (call status, S or D)
- *DISCOUNTS* (rated calls)
- *EVENT_CLASS* (list of classes used)
- *EVENT_COST* (for each named event)
- *EVENT_COUNT* (for each named event)
- *EVENT_NAME* (list used for this call)
- *EVENT_TIME_COST* (for a named event)
- *LOCADD* (additional configuration prefixes)
- *TCS* (ccs time call started)
- *TN* (ccs called number)
- *WALLET_TYPE* (ID of wallet recharged)

Optional EDR 12 fields

This list identifies the optional EDR record fields for a successful roaming SMS-MO (EDR type 12):

- *OVERDRAWN_AMOUNT* (take Balance Negative)
- *REMAINING_CHARGE* (partial Charge)

Optional EDR 13 fields

This list identifies the optional EDR record fields for a successful national SMS-MO (EDR type 13):

- *OVERRIDDEN_TARIFF_PLAN* (ID)
- *TARIFF_CODE* (name)

Account Activated additional fields

If the account is activated, the following fields will be present:

- *NEW_ACCT_STATE* (always active - A)
- *OLD_ACCT_STATE* (pre-call)

Example Account Activated

```
BILLING_ENGINE_ID=21|SCP_ID=36627332|SEQUENCE_NUMBER=487291|CDR_TYPE=13|
RECORD_DATE=20040803142342|ACCT_ID=83|ACCT_REF_ID=83|CLI=016505550185|ACS_CUST_ID=1|
BALANCE_TYPES=1|BALANCES=1000|COSTS=28|ACCOUNT_TYPE=1|CASCADE_ID=1|RATES=50,25|
LENGTHS=120.00,0.00|DISCOUNTS=450000,560000|MAX_CHARGE=500|DURATION=60|TN=016505550100|
TCS=20040803141934|TCE=20040803142034|CS=S|DISCOUNT_TYPE=S*W*R|WALLET_TYPE=1|
LOCADD=E77123016505550100|OLD_ACCT_STATE=P|NEW_ACCT_STATE=A|ACCOUNT_TYPE=1
```

Cross balance type discount additional fields

If the cross balance type discounting has been applied during the call, the following fields will be present:

- *CBTD_BALANCE_TYPES* (list to apply to discounts)
- *CBTD_BALANCE_TYPES* (list to apply to discounts) - mid call rate changes
- *CBTD_BALANCES* (value for each cross balance type)
- *CBTD_BALANCES* (value for each cross balance type) - mid call rate change
- *CBTD_CASCADE_ID* (used for this call)
- *CBTD_CASCADE_ID* (used for this call) - mid call rate change
- *CBTD_COSTS* (costs applied to each cross balance type)
- *CBTD_COSTS* (costs applied to each cross balance type) - mid call rate changes
- *CBTD_DISCOUNTS* (discounts applied to balance types)
- *CBTD_DISCOUNTS* (discounts applied to balance types) - mid call rate changes

Mobile number portability additional fields

If the Mobile Number Portability (MNP) software is installed, the following fields will be present:

- *PORTED* (name of porting carrier)

MSISDN additional fields

If the MSISDN ccsCDRLoader plug-in is installed on the SMS, the following field will be present:

- *MSISDN* (account calling number)

Example EDR 13 (Remove1)

```
BILLING_ENGINE_ID=21|SCP_ID=366273322|SEQUENCE_NUMBER=487291|CDR_TYPE=13|
RECORD_DATE=20040803142342|ACCT_ID=83|ACCT_REF_ID=83|CLI=016505550185|ACS_CUST_ID=1|
BALANCE_TYPES=1|BALANCES=1000|COSTS=28|ACCOUNT_TYPE=1|CASCADE_ID=1|RATES=50,25|
LENGTHS=120.00,40.00|DISCOUNTS=450000,560000|MAX_CHARGE=500|DURATION=160|TN=016505550100|
TCS=20040803141934|TCE=20040803142034|CS=S|DISCOUNT_TYPE=S*W*R|WALLET_TYPE=1|
LOCADD=E77123016505550100|ACCOUNT_TYPE=1
```

Example MSISDN

```
BILLING_ENGINE_ID=21|SCP_ID=366273322|SEQUENCE_NUMBER=487291|CDR_TYPE=13|
RECORD_DATE=20040803142342|ACCT_ID=83|ACCT_REF_ID=83|CLI=016505550185|ACS_CUST_ID=1|
BALANCE_TYPES=1|BALANCES=1000|COSTS=28|ACCOUNT_TYPE=1|CASCADE_ID=1|RATES=50,25|
LENGTHS=120.00,0.00|DISCOUNTS=450000,560000|MAX_CHARGE=500|DURATION=60|TN=016505550100|
TCS=20040803141934|TCE=20040803142034|CS=S|DISCOUNT_TYPE=S*W*R|WALLET_TYPE=1|
LOCADD=E77123016505550100|OLD_ACCT_STATE=P|NEW_ACCT_STATE=A|ACCOUNT_TYPE=1|
MSISDN=016505550185
```

Note

The sequence of all fields output in an EDR is not guaranteed.

Roaming SMS-MO Fails (EDR 1,5,12,13)

Introduction

There are 4 EDR records created for an unsuccessful roaming SMS-MO - EDR type 1, 5, 12 or 13.

Mandatory EDR 1 and 13 fields

This list identifies the mandatory EDR record fields for an unsuccessful national SMS-MO (EDR type 1 or type 13):

- *ACCOUNT_TYPE* (Product Type ID)
- *ACS_CUST_ID* (ACS Customer ID)
- *CLI* (initiating call number)
- *CS* (call status, always D)
- *LOCADD* (additional configuration prefixes)
- *NACK* (short list of codes)
- *TCS* (ccs time call started)
- *TN* (ccs called number)

- *WALLET_TYPE* (ID of wallet changed)

Mandatory EDR 5 and 12 fields

This list identifies the mandatory EDR record fields for an unsuccessful national SMS-MO (EDR type 5 or type 12):

- *ACCOUNT_TYPE* (Product Type ID)
- *ACS_CUST_ID* (ACS Customer ID)
- *CLI* (initiating call number)
- *CS* (call status, always D)
- *EVENT_CLASS* (list of classes used)
- *EVENT_NAME* (list used for this call)
- *LOCADD* (additional configuration prefixes)
- *NACK* (short list of codes)
- *TCS* (ccs time call started)
- *TN* (ccs called number)

Account Activated additional fields

If the account is activated, the following fields will be present:

- *NEW_ACCT_STATE* (always active - A)
- *OLD_ACCT_STATE* (pre-call)

Mobile number portability additional fields

If the Mobile Number Portability (MNP) software is installed, the following fields will be present:

- *PORTED* (name of porting carrier)

MSISDN additional fields

If the MSISDN ccsCDRLoader plug-in is installed on the SMS, the following field will be present:

- *MSISDN* (account calling number)

Example EDR 13 (Remove5)

```
BILLING_ENGINE_ID=21|SCP_ID=230612530|SEQUENCE_NUMBER=487291|CDR_TYPE=13|
RECORD_DATE=20040803121758|ACCT_ID=83|ACCT_REF_ID=83|CLI=016505550185|TN=016505550100|
TCS=20040625124332|CS=D|NACK=INSF|WALLET_TYPE=1|LOCADD=E77123016505550100|ACS_CUST_ID=1
```

Example Account Activated

```
BILLING_ENGINE_ID=21|SCP_ID=230612530|SEQUENCE_NUMBER=487291|CDR_TYPE=13|
RECORD_DATE=20040803121758|ACCT_ID=83|ACCT_REF_ID=83|CLI=016505550185|TN=016505550100|
TCS=20040625124332|CS=D|NACK=INSF|WALLET_TYPE=1|LOCADD=E77123016505550100|ACS_CUST_ID=1|
OLD_ACCT_STATE=P|NEW_ACCT_STATE=A
```

Example MSISDN

```
BILLING_ENGINE_ID=21 | SCP_ID=230612530 | SEQUENCE_NUMBER=487291 | CDR_TYPE=5 |  
RECORD_DATE=20040803121758 | ACCT_ID=83 | ACCT_REF_ID=83 | EVENT_CLASS=SMSMO |  
EVENT_NAME=SMSMO_100 | NACK=INSF | TCS=20040706104957 | CS=D | ACS_CUST_ID=1 | ACCOUNT_TYPE=1 |  
MSISDN=1394111111
```

Note

The sequence of all fields output in an EDR is not guaranteed.

26

SMS-MT

Overview

Introduction

This chapter defines the CCS EDRs for SMS-MT messages.

National SMS-MT Succeeds (EDR 12,13)

Introduction

There are 2 EDR records for a successful National SMS-MT - EDR type 12 and type 13.

Mandatory EDR 12 fields

This list identifies the mandatory EDR record fields for a successful National SMS-MT (EDR type 12):

- *ACCOUNT_TYPE* (Product Type ID)
- *ACS_CUST_ID* (ACS Customer ID)
- *BALANCE_TYPES* (account changed or created)
- *BALANCES* (pre-call or account creation)
- *CASCADE_ID* (balance type cascade IDs)
- *CLI* (initiating call number)
- *DISCOUNTS* (rated calls)
- *EVENT_CLASS* (list of classes used)
- *EVENT_COST* (for each named event)
- *EVENT_COUNT* (for each named event)
- *EVENT_NAME* (list used for this call)
- *EVENT_TIME_COST* (for a named event)
- *LOCADD* (additional configuration prefixes)
- *TCS* (ccs time call started)
- *TN* (ccs called number)
- *WALLET_TYPE* (ID of wallet recharged)

Optional EDR 12 fields

This list identifies the optional EDR record fields for a successful national SMS-MT (EDR type 12):

- *OVERDRAWN_AMOUNT* (take Balance Negative)
- *OVERRIDDEN_TARIFF_PLAN* (ID)
- *REMAINING_CHARGE* (partial Charge)
- *TARIFF_CODE* (name)

Mandatory EDR 13 fields

This table lists the mandatory fields for a successful national SMS-MT (EDR type 13).

- *ACCOUNT_TYPE* (Product Type ID)
- *ACS_CUST_ID* (ACS Customer ID)
- *BALANCE_TYPES* (account changed or created)
- *BALANCES* (pre-call or account creation)
- *CASCADE_ID* (balance type cascade IDs)
- *CLI* (initiating call number)
- *COSTS* (rated calls)
- *CS* (call status, S or D) (call status, S or D)
- *DISCOUNT_TYPE* - one of:
- *DISCOUNT_TYPE* (applied to this call)
- *DISCOUNT_TYPE* (applied to this call) - R*W
- *DISCOUNTS* (rated calls)
- *DURATION* (call length)
- *LENGTHS* - one of:
- *LENGTHS* (rate durations)
- *LENGTHS* (rate durations) -1end duration
- *LOCADD* (additional configuration prefixes)
- *MAX_CHARGE* (for this call)
- *RATES* (rated calls)
- *TCE* (ccs time call ended)
- *TN* (ccs called number)
- *WALLET_TYPE* (ID of wallet changed)

Optional EDR 13 fields

This list identifies the optional EDR record fields for a successful national SMS-MT (EDR type 13):

- *OVERRIDDEN_TARIFF_PLAN* (ID)

- *TARIFF_CODE* (name)

Account Activated additional fields

If the account is activated, the following fields will be present:

- *NEW_ACCT_STATE* (always active - A)
- *OLD_ACCT_STATE* (pre-call)

Cross balance type discount additional fields

If the cross balance type discounting has been applied during the call, the following fields will be present:

- *CBTD_BALANCE_TYPES* (list to apply to discounts)
- *CBTD_BALANCE_TYPES* (list to apply to discounts) - mid call rate changes
- *CBTD_BALANCES* (value for each cross balance type)
- *CBTD_BALANCES* (value for each cross balance type) - mid call rate change
- *CBTD_CASCADE_ID* (used for this call)
- *CBTD_CASCADE_ID* (used for this call) - mid call rate change
- *CBTD_COSTS* (costs applied to each cross balance type)
- *CBTD_COSTS* (costs applied to each cross balance type) - mid call rate changes
- *CBTD_DISCOUNTS* (discounts applied to balance types)
- *CBTD_DISCOUNTS* (discounts applied to balance types) - mid call rate changes

Mobile number portability additional fields

If the Mobile Number Portability (MNP) software is installed, the following fields will be present:

- *PORTED* (name of porting carrier)

MSISDN additional fields

If the MSISDN ccsCDRLoader plug-in is installed on the SMS, the following field will be present:

- *MSISDN* (account calling number)

Example MSISDN

```
BILLING_ENGINE_ID=21 | SCP_ID=230612530 | SEQUENCE_NUMBER=488297 | CDR_TYPE=12 |
RECORD_DATE=20040803145823 | ACCT_ID=61 | ACCT_REF_ID=61 | WALLET_TYPE=1 | CLI=016505550185 |
TN=016505550100 | LOCADD=E771231473289900 | ACS_CUST_ID=1 | CS=S | TCS=20040706104957 |
BALANCE_TYPES=1 | BALANCES=1000 | COSTS=100 | ACCOUNT_TYPE=4 | EVENT_CLASS=SMSMO |
EVENT_NAME=SMSMO_100 | EVENT_COST=100 | EVENT_COUNT=1 | DISCOUNT=0 | CASCADE=0 | OLD_ACCT_STATE=P |
NEW_ACCT_STATE=A | MSISDN=016505550185
```

Note

The sequence of all fields output in an EDR is not guaranteed.

National SMS-MT Fails (EDR 1,5,12,13)

Introduction

There are 4 EDR records created for an unsuccessful national SMS-MT - EDR type 1, 5, 12 or 13.

Mandatory EDR 1 and 13 fields

This list identifies the mandatory EDR record fields for an unsuccessful national SMS-MT (EDR type 1 or type 13):

- *ACCOUNT_TYPE* (Product Type ID)
- *ACS_CUST_ID* (ACS Customer ID)
- *CLI* (initiating call number)
- *CS* (call status, always D)
- *LOCADD* (additional configuration prefixes)
- *NACK* (short list of codes)
- *TCS* (ccs time call started)
- *TN* (ccs called number)
- *WALLET_TYPE* (ID of wallet changed)

Account Activated additional fields

If the account is activated, the following fields will be present:

- *NEW_ACCT_STATE* (always active - A)
- *OLD_ACCT_STATE* (pre-call)

Mobile number portability additional fields

If the Mobile Number Portability (MNP) software is installed, the following fields will be present:

- *PORTED* (name of porting carrier)

Mandatory EDR 5 and 12 fields

This table lists the mandatory fields for an unsuccessful national SMS-MO (EDR type 5 or type 12):

- *ACCOUNT_TYPE* (Product Type ID)
- *ACS_CUST_ID* (ACS Customer ID)
- *CLI* (initiating call number)
- *CS* (call status, always D)
- *EVENT_CLASS* (list of classes used)
- *EVENT_NAME* (list used for this call)

- *LOCADD* (additional configuration prefixes)
- *NACK* (short list of codes)
- *TCS* (ccs time call started)
- *TN* (ccs called number)

MSISDN additional fields

If the MSISDN ccsCDRLoader plug-in is installed on the SMS, the following field will be present:

- *MSISDN* (account calling number)

Example EDR 5 (Remove12)

```
BILLING_ENGINE_ID=21 | SCP_ID=230612530 | SEQUENCE_NUMBER=487291 | CDR_TYPE=5 |
RECORD_DATE=20040803121758 | ACCT_ID=83 | ACCT_REF_ID=83 | BALANCE_TYPES=1 | BALANCES=500 |
EVENT_CLASS=SMSMT | EVENT_NAME=SMSMT_100 | NACK=INSF | TCS=20040706104957 | CS=D | ACS_CUST_ID=1
```

Example MSISDN

```
BILLING_ENGINE_ID=21 | SCP_ID=230612530 | SEQUENCE_NUMBER=487291 | CDR_TYPE=5 |
RECORD_DATE=20040803121758 | ACCT_ID=83 | ACCT_REF_ID=83 | EVENT_CLASS=SMSMO |
EVENT_NAME=SMSMO_100 | NACK=INSF | TCS=20040706104957 | CS=D | ACS_CUST_ID=1 | ACCOUNT_TYPE=1 |
MSISDN=1394111111
```

Note

The sequence of all fields output in an EDR is not guaranteed.

Roaming SMS-MT Succeeds (EDR 12,13)

Introduction

There are 2 EDR records created for a successful roaming SMS-MT - type 12 or 13.

Mandatory EDR 12 fields

This list identifies the mandatory EDR record fields for a successful roaming SMS-MT (EDR type 12):

- *ACCOUNT_TYPE* (Product Type ID)
- *ACS_CUST_ID* (ACS Customer ID)
- *BALANCE_TYPES* (account changed or created)
- *BALANCES* (pre-call or account creation)
- *CASCADE_ID* (balance type cascade IDs)
- *CLI* (initiating call number)
- *COSTS* (rated calls)
- *CS* (*call status, S or D*) (call status, S or D)

- *DISCOUNTS* (rated calls)
- *EVENT_CLASS* (list of classes used)
- *EVENT_COST* (for each named event)
- *EVENT_COUNT* (for each named event)
- *EVENT_NAME* (list used for this call)
- *EVENT_TIME_COST* (for a named event)
- *LOCADD* (additional configuration prefixes)
- *TCS* (ccs time call started)
- *TN* (ccs called number)
- *WALLET_TYPE* (ID of wallet recharged)

Mandatory EDR 13 fields

This table lists the mandatory fields for a successful roaming SMS-MT (EDR type 13).

- *ACCOUNT_TYPE* (Product Type ID)
- *ACS_CUST_ID* (ACS Customer ID)
- *BALANCE_TYPES* (account changed or created)
- *BALANCES* (pre-call or account creation)
- *CASCADE_ID* (balance type cascade IDs)
- *CLI* (initiating call number)
- *COSTS* (rated calls)
- *CS* (call status, always S)
- *DISCOUNT_TYPE* - one of:
- *DISCOUNT_TYPE* (applied to this call)
- *DISCOUNT_TYPE* (applied to this call) - R*W
- *DISCOUNTS* (rated calls)
- *DURATION* (call length)
- *LENGTHS* - one of:
- *LENGTHS* (rate durations)
- *LENGTHS* (rate durations) -1end duration
- *LOCADD* (additional configuration prefixes)
- *MAX_CHARGE* (for this call)
- *RATES* (rated calls)
- *TCE* (ccs time call ended)
- *TCS* (ccs time call started)
- *TN* (ccs called number)
- *WALLET_TYPE* (ID of wallet changed)

Optional EDR 13 fields

This list identifies the optional EDR record fields for a successful national SMS-MT (EDR type 13):

- *OVERRIDDEN_TARIFF_PLAN* (ID)
- *TARIFF_CODE* (name)

Account Activated additional fields

If the account is activated, the following fields will be present:

- *NEW_ACCT_STATE* (always active - A)
- *OLD_ACCT_STATE* (pre-call)

Cross balance type discount additional fields

If the cross balance type discounting has been applied during the call, the following fields will be present:

- *CBTD_BALANCE_TYPES* (list to apply to discounts)
- *CBTD_BALANCE_TYPES* (list to apply to discounts) - mid call rate changes
- *CBTD_BALANCES* (value for each cross balance type)
- *CBTD_BALANCES* (value for each cross balance type) - mid call rate change
- *CBTD_CASCADE_ID* (used for this call)
- *CBTD_CASCADE_ID* (used for this call) - mid call rate change
- *CBTD_COSTS* (costs applied to each cross balance type)
- *CBTD_COSTS* (costs applied to each cross balance type) - mid call rate changes
- *CBTD_DISCOUNTS* (discounts applied to balance types)
- *CBTD_DISCOUNTS* (discounts applied to balance types) - mid call rate changes

Mobile number portability additional fields

If the Mobile Number Portability (MNP) software is installed, the following fields will be present:

- *PORTED* (name of porting carrier)

MSISDN additional fields

If the MSISDN ccsCDRLoader plug-in is installed on the SMS, the following field will be present:

- *MSISDN* (account calling number)

Example EDR 13 (Remove18)

```
BILLING_ENGINE_ID=21|SCP_ID=366273322|SEQUENCE_NUMBER=487291|CDR_TYPE=13|
RECORD_DATE=20040803142342|ACCT_ID=83|ACCT_REF_ID=83|CLI=016505550185|ACS_CUST_ID=1|
BALANCE_TYPES=1|BALANCES=1000|COSTS=28|ACCOUNT_TYPE=1|CASCADE_ID=1|RATES=50,25|
```

```
LENGTHS=120.00,40.00|DISCOUNTS=450000,560000|MAX_CHARGE=500|DURATION=160|TN=016505550100|
TCS=20040803141934|TCE=20040803142034|CS=S|DISCOUNT_TYPE=S*W*R|WALLET_TYPE=1|
LOCADD=E77123016505550100|ROAMING_TYPE=MT|ROAMING_COUNTRY=United Kingdom
```

Example MSISDN

```
BILLING_ENGINE_ID=21|SCP_ID=230612530|SEQUENCE_NUMBER=488297|CDR_TYPE=12|
RECORD_DATE=20040803145823|ACCT_ID=61|ACCT_REF_ID=61|WALLET_TYPE=1|CLI=016505550185|
TN=016505550100|LOCADD=E771231473289900|ACS_CUST_ID=1|CS=S|TCS=20040706104957|
BALANCE_TYPER=1|BALANCES=1000|COSTS=100|ACCOUNT_TYPE=4|EVENT_CLASS=SMSMO|
EVENT_NAME=SMSMO_100|EVENT_COST=100|EVENT_COUNT=1|DISCOUNT=0|CASCADE=0|OLD_ACCT_STATE=P|
NEW_ACCT_STATE=A|MSISDN=016505550185
```

Note

The sequence of all fields output in an EDR is not guaranteed.

Roaming SMS-MT Fails (EDR 1,5,12,13)

Introduction

There are 4 EDR records created for an unsuccessful roaming SMS-MT - EDR type 1, 5, 12 or 13.

Mandatory EDR 1 and 13 fields

This list identifies the mandatory EDR record fields for an unsuccessful national SMS-MT (EDR type 1 or type 13):

- *ACCOUNT_TYPE* (Product Type ID)
- *ACS_CUST_ID* (ACS Customer ID)
- *CLI* (initiating call number)
- *CS* (call status, always D)
- *LOCADD* (additional configuration prefixes)
- *NACK* (short list of codes)
- *TCS* (ccs time call started)
- *TN* (ccs called number)
- *WALLET_TYPE* (ID of wallet changed)

Account Activated additional fields

If the account is activated, the following fields will be present:

- *NEW_ACCT_STATE* (always active - A)
- *OLD_ACCT_STATE* (pre-call)

Mobile number portability additional fields

If the Mobile Number Portability (MNP) software is installed, the following fields will be present:

- *PORTED* (name of porting carrier)

Mandatory EDR 5 and 12 fields

This table lists the mandatory fields for an unsuccessful national SMS-MO (EDR type 5 or type 12):

- *ACCOUNT_TYPE* (Product Type ID)
- *ACS_CUST_ID* (ACS Customer ID)
- *CLI* (initiating call number)
- *CS* (call status, always D)
- *EVENT_CLASS* (list of classes used)
- *EVENT_NAME* (list used for this call)
- *LOCADD* (additional configuration prefixes)
- *NACK* (short list of codes)
- *TCS* (ccs time call started)
- *TN* (ccs called number)

MSISDN additional fields

If the MSISDN ccsCDRLoader plug-in is installed on the SMS, the following field will be present:

- *MSISDN* (account calling number)

Example Account Activated

```
BILLING_ENGINE_ID=21 | SCP_ID=230612530 | SEQUENCE_NUMBER=487291 | CDR_TYPE=13 |  
RECORD_DATE=20040803121758 | ACCT_ID=83 | ACCT_REF_ID=83 | CLI=016505550185 | TN=016505550100 |  
TCS=20040625124332 | CS=D | NACK=INSF | WALLET_TYPE=1 | LOCADD=E77123016505550100 | ACS_CUST_ID=1 |  
OLD_ACCT_STATE=P | NEW_ACCT_STATE=A
```

Example MSISDN

```
BILLING_ENGINE_ID=21 | SCP_ID=230612530 | SEQUENCE_NUMBER=487291 | CDR_TYPE=13 |  
RECORD_DATE=20040803121758 | ACCT_ID=83 | ACCT_REF_ID=83 | CLI=016505550185 | TN=016505550100 |  
TCS=20040625124332 | CS=D | NACK=INSF | WALLET_TYPE=1 | LOCADD=E77123016505550100 | ACS_CUST_ID=1 |  
OLD_ACCT_STATE=P | NEW_ACCT_STATE=A | MSISDN=016505550185
```

Note

The sequence of all fields output in an EDR is not guaranteed.

27

Wallet Credit Transfer

Overview

Introduction

This chapter defines CCS EDRs for inter and intra wallet credit transfers.

Wallet Credit Transfer Succeeds or Fails (EDR 47)

Mandatory EDR 47 fields

This list identifies the mandatory EDR record fields, regardless of whether it succeeds or fails, an inter or intra wallet credit transfer generates this EDR (EDR type 47):

- *CT_NAME* (credit transfer)
- *CT_TYPE* (credit transfer)
- *MSISDN* (account calling number)
- *PURCHASING_ACCT_ID* (purchasing wallet ID)
- *PURCHASING_MSISDN* (purchasing CLI)
- *USER* (operator logon name)
- *VOUCHER_TYPE* (name)

Optional EDR 47 fields

This list identifies the optional EDR record fields for this EDR (EDR type 47):

- *HOST* (initiating credit transfer)

Cost of Credit Transfer Succeeds (EDR 5)

Mandatory EDR 5 fields

This list identifies the mandatory EDR record fields for a successful wallet credit transfer with an associated cost (EDR type 5):

- *ACCOUNT_TYPE* (Product Type ID)
- *ACS_CUST_ID* (ACS Customer ID)
- *BALANCE_TYPES* (existing account)
- *BALANCES* (pre-transaction account balances)

- *CASCADE_ID* (balance type cascade IDs)
- *COSTS* (rated calls)
- *CS* (*call status, S or D*) (call status, S or D)
- *DISCOUNTS* (for each named event)
- *EVENT_CLASS* (list of classes used)
- *EVENT_COST* (for each named event)
- *EVENT_COUNT* (for each named event)
- *EVENT_NAME* (list used for this call)
- *EVENT_TIME_COST* (for a named event)
- *MSISDN* (account calling number)
- *RECIPIENT_ACCT_ID* (receiving wallet ID)
- *RECIPIENT_MSISDN* (receiving CLI)
- *TCS* (ccs time call started)
- *VOUCHER_TYPE* (name)
- *WALLET_TYPE* (ID of wallet recharged)

Optional EDR 5 fields

This list identifies the optional EDR record fields for a successful wallet credit transfer with an associated cost (EDR type 5):

- *OVERDRAWN_AMOUNT* (take Balance Negative)
- *REMAINING_CHARGE* (partial Charge)

Example EDR 5 (Remove17)

```
BILLING_ENGINE_ID=21|SCP_ID=366273322|SEQUENCE_NUMBER=488298|CDR_TYPE=5|
RECORD_DATE=20070719113914|ACCT_ID=61|ACCT_REF_ID=61|ACS_CUST_ID=1|WALLET_TYPE=1|
MSISDN=11012|RECIPIENT_MSISDN=11012|RECIPIENT_ACCT_ID=1021|VOUCHER_TYPE=ATM Reload
Reward|CS=S|TCS=20070723040732|BALANCE_TYPES=1|BALANCES=102970|COSTS=100|ACCOUNT_TYPE=24|
EVENT_CLASS=Oracle Events|EVENT_NAME=Cash-|EVENT_COST=100|EVENT_TIME_COST=0.00|
EVENT_COUNT=1|DISCOUNT=0|CASCADE=1
```

Cost of Credit Transfer Fails (EDR 5)

Mandatory EDR 5 fields

This list identifies the mandatory EDR record fields for a failed wallet credit transfer with an associated cost (EDR type 5):

- *ACCOUNT_TYPE* (Product Type ID)
- *ACS_CUST_ID* (ACS Customer ID)
- *CS* (call status, always D)
- *EVENT_CLASS* (list of classes used)
- *EVENT_NAME* (list used for this call)

- *NACK* (long list of codes)
- *TCS* (ccs time call started)
- *WALLET_TYPE* (ID of wallet recharged)

28

Wallet Migration

Overview

Introduction

This chapter defines CCS EDRs for wallet migration.

Wallet Migration (EDR 54)

Mandatory EDR 54 fields

This list identifies the mandatory EDR record fields for wallet migration (EDR type 54):

- *ACCOUNT_TYPE* (Product Type ID)
- *ACTIVATION_DATE* (account activation date)
- *BALANCE_TYPES* (existing account)
- *BALANCES* (pre-transaction account balances)
- *COSTS* (rated calls)
- *DOMAIN_MIGRATION* (wallet migration)
- *MAX_CONCURRENT* (maximum concurrent accesses allowed)
- *MSISDN* (account calling number)

When the ccsCDRLoader plugin is installed on the SMS, this tag will be present.

- *NEW_ACCT_EXPIRY* (date after update)
- *NEW_BALANCE_EXPIRIES* (date after balance update)
- *OLD_ACCT_EXPIRY* (dates before update)
- *OLD_ACCT_STATE* (before update)
- *OLD_BALANCE_EXPIRIES* (dates before balance update)
- *TERMINAL* (Network ID)
- *USER* (operator logon name)
- *WALLET_DELETED* (always success - Y)

Example EDR 54

```
BILLING_ENGINE_ID=21|SCP_ID=175677458|SEQUENCE_NUMBER=139450184|CDR_TYPE=54|
RECORD_DATE=20090316112330|ACCT_ID=189234|ACCT_REF_ID=20056|USER=SU|
TERMINAL=192.168.25.108|DOMAIN_MIGRATION=Y|BALANCE_TYPES=1,2,3,4,5|
BALANCES=10000,0,0,0,0|COSTS=10000,0,0,0,0|WALLET_DELETED=Y|
ACTIVATION_DATE=20070303122900|NEW_ACCT_EXPIRY=0|MAX_CONCURRENT=1|OLD_ACCT_STATE=P|
```

```
ACCOUNT_TYPE=3|NEW_BALANCE_EXPIRIES=0|OLD_BALANCE_EXPIRIES=20040811100354|  
OLD_ACCT_EXPIRY=20040811100357|MSISDN=1394111111
```

Note

The sequence of all fields output in an EDR is not guaranteed.

29

Wallet Life Cycle

Overview

Introduction

This chapter defines the CCS EDR for wallet life cycle.

Wallet Life Cycle (EDR 55)

Mandatory EDR 55 fields

This list identifies the mandatory EDR record fields for wallet life cycle updates (EDR type 55):

- *ACCOUNT_TYPE* (Product Type ID)
- *CLI* (for the account that will be changed)
- *CS* (*call status, S or D*) (call status, S or D)
- *OLD_WLC_PERIOD* (before update)
- *NEW_WLC_PERIOD* (after update)
- *WALLET_TYPE* (ID of wallet changed)

Optional EDR 55 fields

This list identifies the optional EDR record fields for this EDR (EDR type 55):

- *NEW_WLC_PLAN* (Id)
- *OLD_WLC_PLAN* (Id)

Note

The sequence of all fields output in an EDR is not guaranteed.

30

Credit Card Updates

Overview

Introduction

This chapter describes the CCS EDRs for operator updates to credit cards by using the CCS user interface (UI).

Note: The EDR fields in this section are listed alphabetically. The actual sequence of the fields output in an EDR is likely to be different.

Credit Card EDRs (Types 57, 58, 59, 60, 61, 62, 63, and 64)

About EDRs for Operator Updates to Subscriber Credit Card Records

An EDR is generated each time an operator updates the credit card details for a subscriber through the CCS UI. When the operator:

- Adds a new credit card for a subscriber, a type 57 EDR is generated
- Deletes a subscriber's credit card, a type 58 EDR is generated
- Registers a credit card to a subscriber, a type 59 EDR is generated
- Deregisters a credit card from a subscriber, a type 60 EDR is generated
- Freezes a subscriber's credit card, a type 61 EDR is generated
- Activates a subscriber's credit card, a type 62 EDR is generated
- Confirms a credit card to a subscriber, a type 63 EDR is generated
- Modifies a subscriber's credit card, a type 64 EDR is generated

These EDRs output all the same mandatory fields.

Mandatory Credit Card EDR Fields (Type 57 to Type 64)

This list identifies the mandatory EDR record fields for operator updates to a subscriber's credit card records:

- *ACCOUNT_TYPE* (Product Type ID)
- *CLI* (for the account that will be changed)
- *DISPLAY_NUMBER* (credit card)
- *EXPIRY_DATE* (for a credit card)
- *NAME_ON_CARD* (for a credit card)
- *MSISDN* (subscriber ids)

-
- *REASON* (change reason)
 - *RECORD_DATE* (date edr created)
 - *TERMINAL* (Network ID)
 - *USER* (operator logon name)
 - *WALLET_TYPE* (ID of wallet changed)

31

Billing Engine Control Plan Invocation

Overview

Introduction

This chapter defines CCS EDRs for billing engine control plan invocation.

Control Plan Service Invoke (EDR 7)

Mandatory EDR 7 fields

This list identifies the mandatory EDR record fields for control plan service invoke (EDR type 7):

- *CLI* (initiating call number)
- *Called Number*
- *Control Plan* (name of invoked control plan)
- *Service Handle* (invoked service handle)
- *Service Response* (from service function)

Note

The sequence of all fields output in an EDR is not guaranteed.

32

CCS EDR Tag Definitions

Overview

Introduction

This chapter lists the Event Data Record (EDR) file tag definitions created by CCS processes.

CCS EDR Tag List

EDR tags

The following list details the tag values of EDRs created by the CCS service, the type and length of data required, and a description of the value.

ACCOUNT_TYPE (Product Type ID)

Description:	The ID of the account type (product type) for this account.
Format:	Integer
Version:	CCC 6.0.0
Notes:	This is the database ID of the CCS product type from the CCS_ACCT_REFERENCE table, ID column. This will be set to 0 (zero) for balance expiries.
Example:	ACCOUNT_TYPE=1

ACCT_ID (changed wallet ID)

Description:	The ID of the account's wallet that changed during the call's processing. An account may have multiple wallets 'Personal' and 'Business' so it is necessary to identify which wallet changed.
Format:	Integer
Version:	CCC 6.0.0
Notes:	This is an internal wallet reference only (ccs_acct.BE_ACCT_ID or be_wallet.ID).
Example:	ACCT_ID=1021

ACCT_REF_ID (changed account ID)

Description:	The ID of the account that changed during the call's processing.
Format:	Integer
Version:	CCC 6.0.0

Notes:	<ul style="list-style-type: none"> This is an internal account reference only (ccs_acct_reference.ID) If this field for an expiry EDR is set to zero (0), this indicates that the change was not limited to a single account but was applied to the wallet or balance of all the referenced accounts..
Example:	ACCT_REF_ID=0

ACS_CUST_ID (ACS Customer ID)

Description:	The ID of the ACS customer for this account.
Format:	Integer
Version:	CCC 6.0.0
Notes:	This is an internal ACS customer reference only (acs_customer.ID).
Example:	ACS_CUST_ID=1

ACTION (voucher activity)

Description:	The action or activity performed on a voucher.
Format:	String
Version:	CCC 6.0.1
Notes:	<p>Values can be:</p> <ul style="list-style-type: none"> VCU: Voucher Channel Used VTC: Voucher Type Created VTM: Voucher Type Modified VTD: Voucher Type Deleted VBC: Voucher Batch Created VBE: Voucher Batch Edited VBD: Voucher Batch Deleted VSC: Voucher State Changed VVD: Voucher Validated VRC: Voucher Recharged PKI: Public Key Imported PKV: Public Key Verified VEC: Voucher Expiry Changed VES: Voucher Expiry and State Changed
Example:	ACTION=VSC

ACTION_DETAIL (voucher activity)

Description:	Additional details of the specified action.
Format:	String
Version:	CCC 6.0.1

Notes:	<p>For example, If the ACTION is VSC (Voucher State Changed), then ACTION_DETAIL can have any of the following values, which indicate the new voucher state:</p> <ul style="list-style-type: none"> • C = Created • A = Active • F = Frozen • D = Deleted <p>The other ACTION field values are as follows:</p> <ul style="list-style-type: none"> • VCU: <not used> • VRC: "Success" or "Failure" • VVD: "Success" or "Failure" • PKV: "Success" or "Failure" • PKI: Displays the public key name and description • VTC: Displays the voucher name • VTM: Displays the changed value for type. For example, name of the voucher type. • VTD: Displays voucher name • VBC: Displays batch name • VBE: Displays the change. For example, for a status change, displays "Status Changed to " <i>new_status</i> • VBD: Displays batch name • VEC: Displays the voucher expiry change with details (new date:description) • VES: Displays the voucher expiry and state with details (new date:state:description). If voucher expiry date is set to an earlier date (a past date), then the voucher state displayed will be "Expired".
Example:	ACTION_DETAIL=A

ACTIVATION_DATE (account activation date)

Description:	The activation date for the account.
Format:	Date (yyyymmddhhmmss format)
Version:	CCC 6.0.0
Notes:	'0' indicates that the activation date for the account is not set.
Example:	ACTIVATION_DATE=20040703122900

ADJUSTMENT (generated by an adjustment)

Description:	Was this EDR generated by an adjustment.
Format:	Boolean
Version:	CCC 6.0.0
Notes:	
Example:	

APPLICATION_DESC (application freeform)

Description:	A freeform reference string entered by the application that made the reservation.
Format:	String
Version:	CCC 6.0.0
Notes:	
Example:	APPLICATION_DESC=OSA Reservation Amount

BAD_PINS (number of attempts)

Description:	The pre-transaction bad PIN attempts for this account.
Format:	Integer
Version:	CCC 6.0.0
Notes:	
Example:	BAD_PINS=1

BALANCE_EXPIRIES (period hours)

Description:	The balance expiry period in hours.
Format:	Integer
Version:	CCC 6.0.0
Notes:	
Example:	BALANCE_EXPIRIES=100

BALANCE_NAMES

Description:	The balance names that correspond to the ID's in the BALANCE_TYPES field.
Format:	String
Version:	CCC 6.0.0
Notes:	
Example:	BALANCE_NAMES=Roam Zone 3 MB

BALANCE_TYPES (account changed or created)

Description:	<p>A list of the balance types that changed or were created during the call.</p> <p>An account may have balance type IDs that correspond to the following balance type names:</p> <ul style="list-style-type: none"> • General Cash • Promotional Cash • Free SMS <p>For multi tariff rated calls, this is a comma separated list of the service ID and the balance type that was changed by that service ID.</p>
Format:	Integer(s)
Version:	CCC 6.0.0
Notes:	<ul style="list-style-type: none"> • This is an internal reference to the balance type ids only (ccs_balance_type.ID). • The service ID and Balance type are colon separated.
Example:	<p>Single tariff:</p> <p>BALANCE_TYPES=1, 2, 5</p> <p>Multi tariff:</p> <p>BALANCE_TYPES=service ID1:1,service ID2:49</p>

BALANCE_TYPES (account changed or created) - mid call rate change

Description:	<p>A list of the balance types that changed or were created during the call.</p> <p>An account may have balance type IDs that correspond to the following balance type names:</p> <ul style="list-style-type: none"> • General Cash • Promotional Cash • Free SMS <p>For multi tariff rated calls, this is a comma separated list of the service ID and the balance type that was changed by that service ID.</p> <p>For single tariff calls with mid call rate changes, this is a semi colon separated list of the tariff plan ID, time stamp and balance type for each rate change. The tariff plan ID, time stamp and balance type are colon separated.</p> <p>For multi tariff calls with mid call rate changes, then the service ID:balance type combinations are included in the list as well.</p>
Format:	Integer(s)
Version:	CCC 6.0.0
Notes:	<ul style="list-style-type: none"> • This is an internal reference to the balance type ids only (ccs_balance_type.ID). • The service ID and balance type are colon separated.
Example:	Single tariff: BALANCE_TYPES=1, 2, 5
	Multi tariff: BALANCE_TYPES=service ID1:1,service ID2:49
	Single tariff mid call rate change: BALANCE_TYPES=Tariff Plan ID1:Time Stamp:64;Tariff Plan ID2:Time Stamp:64
	Multi tariff mid call rate change: BALANCE_TYPES=Tariff Plan ID1:Time Stamp:Service ID1:64:Service ID2:64;Tariff Plan ID2:Time Stamp:Service ID1:64:Service ID2:64

BALANCE_TYPES (existing account)

Description:	<p>A list of the balance types that currently exist for this account.</p> <p>An account may have balance types IDs that correspond to the following balance type names:</p> <ul style="list-style-type: none"> • General Cash • Promotional Cash • Free SMS
Format:	List of integer numbers
Version:	CCC 6.0.0
Notes:	This is an internal reference to the balance type IDs only (ccs_balance_type.ID).
Example:	BALANCE_TYPES=1

BALANCES (pre-call or account creation)

Description:	A list of the pre-call account balance values for each account. For multi tariff rated calls, this is a comma separated list of the service ID (as listed in BALANCE_TYPES) and the balance that was changed by that service ID. The service ID and balance are colon separated.
Format:	Integer or Float
Version:	CCC 6.0.0
Notes:	Float type if time balances (two decimal places), integer type if currency balances.
Example:	Single tariff: BALANCES=0,0,0
	Multi tariff: BALANCES=service ID1:1000,service ID2:10000

BALANCES (pre-call or account creation) - mid call rate change

Description:	A list of the pre-call account balance values for each account. For multi tariff rated calls, this is a comma separated list of the service ID (as listed in BALANCE_TYPES) and the balance that was changed by that service ID. The service ID and balance are colon separated. For calls with mid call rate changes, this is a semi colon separated list of the tariff plan id, time stamp and balance that was changed. The tariff plan ID, time stamp and balance are colon separated. For multi tariff rated calls with mid call rate changes, then the service ID:balance combinations are included in the list as well.
Format:	Integer or Float
Version:	CCC 6.0.0
Notes:	Float type if time balances (two decimal places), integer type if currency balances.
Example:	Single tariff: BALANCES=0,0,0
	Multi tariff: BALANCES=service ID1:1000,service ID2:10000
	Single tariff mid call rate change: BALANCES=Tariff Plan ID1:Time Stamp:1000;Tariff Plan ID2:Time Stamp:1000
	Multi tariff mid call rate change: BALANCES=Tariff Plan ID1:Time Stamp:Service ID1:1000:Service ID2:10000;Tariff Plan ID2:Time Stamp:Service ID1:1000:Service ID2:10000

BALANCES (pre-transaction account balances)

Description:	A list of the pre-transaction account balance values for each balance type ID. For multi tariff rated calls, this is a comma separated list of the service ID (as listed in BALANCE_TYPES) and the balance that was changed by that service ID.
Format:	Integer or Float
Version:	CCC 6.0.0
Notes:	<ul style="list-style-type: none"> The service ID and balance are colon separated. Float type if time balances (two decimal places), integer type if currency balances.
Example:	Single tariff: BALANCES=2000,0
	Multi tariff: BALANCES=service ID1:1000,service ID2:10000

BARCODE (voucher details)

Description:	The barcode number of the voucher.
Format:	Integer
Version:	CCC 12.0.1
Notes:	You can use a maximum of 12 digits.
Example:	BARCODE=12

BARRED_LIST_TYPE (description)

Description:	The list type description.
Format:	String
Version:	CCC 6.0.0
Notes:	Values can be: <ul style="list-style-type: none"> Allowed Barred
Example:	BARRED_LIST_TYPE=ALLOWED

BATCH_DESCRIPTION (for voucher batch)

Description:	The textual description for the voucher batch.
Format:	String
Version:	CCC 6.0.0
Notes:	
Example:	BATCH_DESCRIPTION=Test Batch

BEARER_TYPE (bearer type for promotions)

Description:	The bearer for the balance recharge event. This indicates the type of service used for performing the recharge, such as voice or SMS.
---------------------	---

Format:	String
Version:	CCC 5.0.2
Notes:	This is an optional field, available only for a flash promotion where the event category selected is Balance Recharge .
Example:	BEARER_TYPE=voice

BILLING_ENGINE_ID (BE where account resides)

Description:	The ID of the billing engine where this account resides.
Format:	Integer
Version:	CCC 6.0.0
Notes:	This is an internal reference only (ccs_acct.BE_ACCT_ENGINE_ID).
Example:	BILLING_ENGINE_ID=21

BONUS_TYPE (name)

Description:	The name of the bonus type applying to this recharge.
Format:	String
Version:	CCC 6.0.0
Notes:	Values can be: <ul style="list-style-type: none"> • CREDIT CARD • CUSTOM. Warning: This value must be in upper case format for bonus to be applied.
Example:	BONUS_TYPE=CUSTOM

BUCKET_IDS (within balance type recharged)

Description:	A list of the bucket IDs within the balance type that were credited or debited during this recharge.
Format:	Integer
Version:	CCC 6.0.0
Notes:	This is an internal bucket reference only (be_bucket.ID).
Example:	BUCKET_IDS=45844

BUCKET_LEVEL_COSTS

Description:	Lists the bucket level costs applied to each balance type.
Format:	Integer(s)
Version:	CCC 15.0

Notes:	Format is as follows: BUCKET_LEVEL_COSTS=balanceType:BucketId:cost For mid-session EDR enabled scenarios, BUCKET_LEVEL_COSTS tag will be present only in the mid-session EDRs and not in the final EDR.
Example:	BUCKET_LEVEL_COSTS=1:736:10,161:1340:150

CALLED_NUMBER

Description:	The number being called.
Format:	String
Version:	CCC 6.0.0
Notes:	
Example:	CALLED_NUMBER=01473516345

CARD DESIGN (voucher details)

Description:	Version number of the voucher design.
Format:	Integer
Version:	CCC 12.0.1
Notes:	You can use a maximum of 4 digits.
Example:	CARD_DESIGN=90

CASCADE (always empty for pi)

Description:	This PI command will always produce an empty value for this field.
Format:	Integer
Version:	CCC 6.0.0
Notes:	
Example:	CASCADE=

CASCADE_ID (balance type cascade IDs)

Description:	This is the ID of the balance type cascade that was used for this call. An account will have a balance type cascade that lists the order in which the account's balance types will be debited or credited for each call. For multi tariff rated calls, this is a comma separated list of the service ID and cascade IDs for each of the tariffs in the rate. The service ID and cascade ID are colon separated.
Format:	Integer(s)
Version:	CCC 6.0.0
Notes:	This is an internal reference to the balance cascade ID only (ccs_balance_type_cascade.ID).
Example:	Single tariff: CASCADE_ID=44

	Multi tariff: CASCADE_ID=service ID1:1,service ID2:49
--	--

CASCADE_ID (balance type cascade IDs) - mid call rate change

Description:	<p>This is the ID of the balance type cascade that was used for this call.</p> <p>An account will have a balance type cascade that lists the order in which the account's balance types will be debited or credited for each call.</p> <p>For multi tariff rated calls, this is a comma separated list of the service ID and cascade IDs for each of the tariffs in the rate. The service ID and cascade ID are colon separated.</p> <p>For calls with mid call rate changes, this is a semi colon separated list of the tariff plan ID, time stamp and cascade IDs for each rate. The tariff plan ID, time stamp and cascade IDs are colon separated.</p> <p>For multi tariff calls with mid call rate changes, then the service ID is included in the list as well.</p>
Format:	Integer(s)
Version:	CCC 6.0.0
Notes:	This is an internal reference to the balance cascade ID only (ccs_balance_type_cascade.ID).
Example:	Single tariff: CASCADE_ID=44
	Multi tariff: CASCADE_ID=service ID1:1,service ID2:49
	Single tariff mid call rate change: CASCADE_ID=Tariff Plan ID1:Time Stamp:1;Tariff Plan ID2:Time Stamp:1
	Multi tariff mid call rate change: CASCADE_ID=Tariff Plan ID1:Time Stamp:Service ID1:1:Service ID2:1;Tariff Plan ID2:Time Stamp:Service ID1:1:Service ID2:1

CBTD_BALANCE_TYPES (list to apply to discounts)

Description:	A list of the cross balance types used during the call to apply the cross balance type discounts.
Format:	Integer(s)
Version:	CCC 6.0.0
Notes:	
Example:	CBTD_BALANCE_TYPES=174

CBTD_BALANCE_TYPES (list to apply to discounts) - mid call rate change

Description:	A list of the cross balance types used during the call to apply the cross balance type discounts. For calls with mid call rate changes the tariff plan ID and time stamp for each rate change will also be listed. Items in the list are colon separated.
Format:	Integer(s)
Version:	CCC 6.0.0
Notes:	
Example:	Single rate: CBTD_BALANCE_TYPES=174
	Mid call rate change: CBTD_BALANCE_TYPES=Tariff Plan ID1:Time Stamp:2,4;Tariff Plan ID2:Time Stamp:2,4

CBTD_BALANCES (value for each cross balance type)

Description:	A list of the balance values for each cross balance type displayed in the CBTD_BALANCE_TYPE field of the EDR record.
Format:	Integer(s) or float
Version:	CCC 6.0.0
Notes:	Float type if time balances (two decimal places), Integer type if currency balances.
Example:	CBTD_BALANCES=440.00

CBTD_BALANCES (value for each cross balance type) - mid call rate change

Description:	A list of the balance values for each cross balance type displayed in the CBTD_BALANCE_TYPE field of the EDR record. For calls with mid call rate changes, this is a semi colon separated list of the tariff plan ID, time stamp and balance that was changed. The tariff plan ID, time stamp and balance are colon separated.
Format:	Integer(s) or Float
Version:	CCC 6.0.0
Notes:	Float type if time balances (two decimal places), integer type if currency balances.
Example:	Single tariff: CBTD_BALANCES=440.00
	Mid call rate change: CBTD_BALANCES=Tariff Plan ID1:Time Stamp:1000;Tariff Plan ID2:Time Stamp:1000

CBTD_CASCADE_ID (used for this call)

Description:	This lists the order in which the account's cross balance types will be debited during calls. It is only present where a cross balance type discount has been applied.
Format:	Integer
Version:	CCC 6.0.0
Notes:	This is an internal reference to the cross balance cascade ID only.
Example:	

CBTD_CASCADE_ID (used for this call) - mid call rate change

Description:	This lists the order in which the account's cross balance types will be debited during calls. It is only present where a cross balance type discount has been applied. For calls with mid call rate changes, this is a semi colon separated list of the tariff plan ID, time stamp and cascade IDs for each rate. The tariff plan ID, time stamp and cascade IDs are colon separated.
Format:	Integer
Version:	CCC 6.0.0
Notes:	This is an internal reference to the cross balance cascade ID only.
Example:	Single tariff: CASCADE_ID=44,33
	Mid call rate change: CASCADE_ID=Tariff Plan ID1:Time Stamp:1;Tariff Plan ID2:Time Stamp:1

CBTD_COSTS (costs applied to each cross balance type)

Description:	Lists the costs applied to each cross balance type ID displayed in the CBTD_BALANCE_TYPE field of the EDR record.
Format:	Integer(s) or Float
Version:	CCC 6.0.0
Notes:	Float type if time balances (two decimal places), Integer type if currency balances.
Example:	CBTD_COSTS=440.00

CBTD_COSTS (costs applied to each cross balance type) - mid call rate change

Description:	Lists the costs applied to each cross balance type ID displayed in the CBTD_BALANCE_TYPE field of the EDR record. For calls with mid call rate change the tariff plan ID and time stamp for each rate change are also included. Items in the list are colon separated.
Format:	Integer(s) or float

Version:	CCC 6.0.0
Notes:	Float type if time balances (two decimal places), integer type if currency balances.
Example:	Single call rate time balance: CBTD_COSTS=440.00
	Mid call rate change currency balance: CBTD_COSTS=Tariff Plan ID1:Time Stamp:30,5,0;Tariff Plan ID2:Time Stamp:30,5,0

CBTD_COSTS_RND_REM (rounding remainder of cross balance CBTD_COSTS)

Description:	A list of rounding remainder of each cost displayed in the CBTD_COSTS field of the EDR record.
Format:	Float(s)
Version:	CCC 12.0
Notes:	Floating point remainder in decimal or scientific notation.
Example:	CBTD_COSTS_RND_REM=3.552714e-15,-3.911111

CBTD_DISCOUNTS (discounts applied to balance types)

Description:	Lists the cross balance type discounts (in 1/10000's of a percent) applied during this call to the chargeable balance types.
Format:	Integer(s)
Version:	CCC 6.0.0
Notes:	
Example:	CBTD_DISCOUNTS=200000

CBTD_DISCOUNTS (discounts applied to balance types) - mid call rate change

Description:	Lists the cross balance type discounts (in 1/10000's of a percent) applied during this call to the chargeable balance types. For calls with mid call rate changes the tariff plan ID and time stamp for each rate change are also included. Items in the list are colon separated.
Format:	Integer(s)
Version:	CCC 6.0.0
Notes:	
Example:	Single call rate: CBTD_DISCOUNTS=200000

	<p>Mid call rate change:</p> <pre>CBTD_DISCOUNTS=Tariff Plan ID1:Time Stamp:200000,100000;Tariff Plan ID2:Time Stamp:200000,100000</pre>
--	--

CDR_TYPE (reason for record generation)

Description:	The reason that the EDR record was generated. This will be the result of either a CCS or other service. The extra information fields, which are present in the resulting EDR record, are dependent on the EDR type.
Format:	String
Version:	CCC 6.0.0
Notes:	
Example:	CDR_TYPE=2

CHANNEL (for rewards)

Description:	<p>The channel for the balance recharge event. This indicates the mechanism used for performing the recharge. The following default global channels are provided:</p> <ul style="list-style-type: none"> • ATM • Any • MPOS • Other • Voucher
Format:	String
Version:	CCC 6.0.0
Notes:	<p>This is an optional field, available only for a flash promotion where the promotional balance type is</p> <pre>Balance Recharge .</pre>
Example:	CHANNEL=ATM

CHARGE_EXPIRY (new periodic charge expiry)

Description:	The new date the periodic charge will expire.
Format:	Date (yyyymmddhhmmss format)
Version:	CCC 6.0.0
Notes:	
Example:	CHARGE_EXPIRY=20110122221708

CHARGE_NAME (of periodic charge)

Description:	The name of the periodic charge applied.
Format:	String
Version:	CCC 6.0.0
Notes:	
Example:	

CLI (initiating call number)

Description:	The calling line identifier (calling number) that initiated the call.
Format:	String
Version:	CCC 6.0.0
Notes:	This is the party making the call, and is the value stored in cs_acct_reference.CLI unless the location area code (LAC) is used to initiate the call. In this case, the CLI is made up from the mobile country code (MCC), mobile network code (MNC), LAC, and cell ID.
Example:	CLI=01206233252

CLI (initiating call number) - mid call rate change

Description:	The calling line identifier (calling number) that initiated the call. For calls with mid call rate changes, this is a semi colon separated list of the tariff plan ID, time stamp and CLI for each rate. The tariff plan ID, time stamp and CLI are colon separated.
Format:	String
Version:	CCC 6.0.0
Notes:	This is the party making the call, and is the value stored in cs_acct_reference.CLI unless the location area code (LAC) is used to initiate the call. In this case, the CLI is made up from the mobile country code (MCC), mobile network code (MNC), LAC, and cell ID.
Example:	Single call rate: CLI=01206233252
	Mid call rate change: CLI=Tariff Plan ID1:Time Stamp:44111110;Tariff Plan ID2:Time Stamp:44111110

CLI (for the account that will be changed)

Description:	The calling line identifier for the account which will be changed.
Format:	String
Version:	CCC 6.0.0
Notes:	From ccs_acct_reference.CLI
Example:	CLI=1234

CLI (roaming initiating call number)

Description:	The calling line identifier (calling number) that initiated the call. This is the party making the call, and is the value stored in cs_acct_reference.CLI unless the location area code (LAC) is used to initiate the call. In this case, the CLI is made up from the mobile country code (MCC), mobile network code (MNC), LAC, and cell ID.
Format:	String
Version:	CCC 6.0.0
Notes:	<ul style="list-style-type: none"> The Roaming software provides a ccsCDRLoaderPlugin on the SMP. This plug-in will determine the type of roaming call. If a CAMEL Originating call is determined, then the roaming prefix will be stripped from the CLI field.
Example:	CLI=016505550185

COMPONENT (from pi command reference)

Description:	A freeform reference string taken from the PI COMMAND REFERENCE field.
Format:	String
Version:	CCC 6.0.0
Notes:	This is the reference entered by the operator that performed the recharge.
Example:	

CONTROL_PLAN (name of invoked control plan)

Description:	The name of the invoked control plan
Format:	String
Version:	CCC 6.0.0
Notes:	
Example:	CONTROL_PLAN=SrmPlan

COSTS (rated calls)

Description:	<p>A list of the costs debited or credited from each service ID displayed in the BALANCE_TYPES field of the EDR record. For a 'Debit' account, a credit to the account will be indicated by a negative value.</p> <p>For multi tariff rated calls, the costs will also be broken down by the service ID used to identify each tariff. All balance types used will be listed against each service id even if there was no charge.</p>
Format:	Integer or float
Version:	CCC 6.0.0
Notes:	Float type if time balances (two decimal places), integer type if currency balances.
Example:	<p>Single tariff: COSTS=120</p> <p>Multi tariff: COSTS=service ID1:5,5,service ID2:10,0</p>

COSTS (rated calls) - mid call rate change

Description:	<p>A list of the costs debited or credited from each service ID displayed in the BALANCE_TYPES field of the EDR record. For a 'Debit' account, a credit to the account will be indicated by a negative value.</p> <p>For multi tariff rated calls, the costs will also be broken down by the service ID used to identify each tariff. All balance types used will be listed against each service id even if there was no charge.</p> <p>For calls with mid call rate changes, the costs will be broken down by tariff plan ID and time stamp for each rate change. The tariff plan ID, time stamp and costs are colon separated.</p> <p>For multi tariff rated calls with mid call rate changes, then the service ID is included as well.</p>
Format:	Integer or float
Version:	CCC 6.0.0
Notes:	Float type if time balances (two decimal places), integer type if currency balances.
Example:	<p>Single tariff: COSTS=120</p>
	<p>Multi tariff: COSTS=service ID1:5,5,service ID2:10,0</p>
	<p>Single tariff mid call rate change: COSTS=Tariff Plan ID1:Time Stamp:10;Tariff Plan ID2:Time Stamp:20</p>
	<p>Multi tariff mid call rate change: COSTS=Tariff Plan ID1:Time Stamp:Service ID1:10:Service ID2:0;Tariff Plan ID2:Time Stamp:Service ID1:20:Service ID2:0</p>

COSTS_RND_REM (rounding remainder of balance COSTS)

Description:	A list of rounding remainder of each cost displayed in the COSTS field of the EDR record.
Format:	Float(s)
Version:	CCC 12.0
Notes:	Floating point remainder in decimal or scientific notation.
Example:	COSTS_RND_REM=3.552714e-15, -3.911111

CS (call status, S or D)

Description:	The call status.
Format:	String
Version:	CCC 6.0.0

Notes:	This value will usually be 'S' (Success) for this EDR record. For EDR types 5, 12, 25, 27, 32 and 49, the success EDR will be returned with a call status of 'D' if a partial charge occurred or if the balance became negative as a result of the charge. This scenario can only occur if your insufficient funds policy is configured either to take a wallet balance negative or process a partial charge. If your configuration allows negative balances, the EDR includes the optional field OVERDRAWN_AMOUNT . If a partial charge occurs, the EDR includes the optional field REMAINING_CHARGE .
Example:	CS=S, CS=D

CT_NAME (credit transfer)

Description:	Credit transfer name.
Format:	String
Version:	CCC 6.0.0
Notes:	From CCS_CREDIT_TRANSFER.name.
Example:	

CT_TYPE (credit transfer)

Description:	Credit transfer type.
Format:	String
Version:	CCC 6.0.0
Notes:	From CCS_CREDIT_TRANSFER.type.
Example:	

CUG_NAME (closed user group)

Description:	The name of the closed user group (CUG) for the current call.
Format:	String
Version:	CCC 6.0.0
Notes:	
Example:	

DICWR (Disable Incoming Calls When Roaming)

Description:	A Flag indicating whether the 'Disable Incoming Calls When Roaming' flag has been enabled or disabled.
Format:	String
Version:	CCC 6.0.0
Notes:	Valid values are: <ul style="list-style-type: none"> • TRUE • FALSE
Example:	DICWR=TRUE

DISCOUNT (always zero for pi)

Description:	This PI command will always produce a value of zero for this field.
Format:	Integer
Version:	CCC 6.0.0
Notes:	
Example:	DISCOUNT=0

DISCOUNT_TYPE (applied to this call)

Description:	The discount type applied to this call.
Format:	String
Version:	CCC 6.0.0
Notes:	Valid values are: <ul style="list-style-type: none"> • BASIC' • COMPOUND' • CUMULATIVE • OVERRIDE
Example:	DISCOUNT_TYPE=BASIC

DISCOUNT_TYPE (applied to this call)

Description:	The discount type applied to this call.
Format:	String
Version:	CCC 6.0.0
Notes:	The value is the uppercase value of the discountRuleType parameter. See <i>CCS Technical Guide</i> - ccsReservationHandler topic.
Example:	DISCOUNT_TYPE="S*W*R"

DISCOUNT_TYPE (applied to this call) - service discount

Description:	The discount type applied to this call.
Format:	String
Version:	CCC 6.0.0
Notes:	The value is the uppercase value of the discountRuleType parameter. See <i>CCS Technical Guide</i> - ccsReservationHandler topic. The S character in the value string will only be included when a service discount has been used. As a result, the possible values depend on both the configured discountRuleType parameter and the presence of a service discount for this call. This allows correlation with CCC 6.0.0 values, where the: <ul style="list-style-type: none"> • Presence of the S character maps to COMPOUND, CUMMULATIVE or OVERRIDE • Absence of the S character maps to BASIC

Example:	<p>With service discount: DISCOUNT_TYPE=S*R*W</p> <p>Without service discount: DISCOUNT_TYPE=R*W</p>
-----------------	--

DISCOUNTS (for each named event)

Description:	A list of discounts (in 1/10000's of a percent) that correspond to each named event that is specified in the EVENT_NAME field of this EDR record.
Format:	Integer or Float
Version:	CCC 6.0.0
Notes:	<ul style="list-style-type: none"> This field is determined by the tariff associated with this named event and is not fixed for a specific account. Float type if time balances (two decimal places), Integer type if currency balances.
Example:	DISCOUNTS=200000

DISCOUNTS (rated calls)

Description:	<p>This will be a list of discounts (in 1/10000's of a percent) that exist for this call.</p> <p>For multi tariff rated calls this is a comma separated list of the service ID (as listed in the BALANCE_TYPER) used to identify the tariff followed by a colon and the list of associated charge period discounts for each of the tariffs in the rate. The service ID and discount list are colon separated.</p>
Format:	Integer or Float
Version:	CCC 6.0.0
Notes:	<ul style="list-style-type: none"> This field is determined by the tariff associated with this call and is not fixed for a specific account. Float type if time balances (two decimal places), Integer type if currency balances.
Example:	<p>Single tariff: DISCOUNTS=0</p> <p>Multi tariff: DISCOUNTS=service ID1:0,0,0,0,service ID2:0,0,0,0</p>

DISCOUNTS (rated calls) - mid call rate change

Description:	<p>This will be a list of discounts (in 1/10000's of a percent) that exist for this call.</p> <p>For multi tariff rated calls this is a comma separated list of the service ID (as listed in the BALANCE_TYPES) used to identify the tariff followed by a colon and the list of associated charge period discounts for each of the tariffs in the rate. The service ID and discount list are colon separated.</p> <p>For calls with mid call rate changes, the discounts will be broken down by tariff plan ID and the time stamp for each rate change. The tariff plan ID, time stamp and discount list are colon separated.</p> <p>For multi tariff rated calls with mid call rate changes, then the Service ID is included in the list as well.</p>
Format:	Integer or float
Version:	CCC 6.0.0
Notes:	<ul style="list-style-type: none"> This field is determined by the tariff associated with this call and is not fixed for a specific account. Float type if time balances (two decimal places), Integer type if currency balances.
Example:	<p>Single tariff:</p> <p>DISCOUNTS=0</p>
	<p>Multi tariff:</p> <p>DISCOUNTS=service ID1:0,0,0,0,service ID2:0,0,0,0</p>
	<p>Single tariff mid call rate change:</p> <p>DISCOUNTS=Tariff Plan ID1:Time Stamp:0,0,0,0;Tariff Plan ID2:Time Stamp:0,0,0,0</p>
	<p>Multi tariff mid call rate change:</p> <p>DISCOUNTS=Tariff Plan ID1:Time Stamp:Service ID1:0,0,0,0:Service ID2:0,0,0,0;Tariff Plan ID2:Time Stamp:Service ID1:0,0,0,0:Service ID2:0,0,0,0</p>

DISPLAY_NUMBER (credit card)

Description:	The credit card number. For security reasons, some digits will have been replaced by the * character. The number of digits replaced depends on the credit card masking rules that have been set for the service provider.
Format:	String
Version:	CCC 6.0.0
Notes:	For more information about credit card masking rule configuration, see <i>Charging Control Services User's Guide</i> .
Example:	DISPLAY_NUMBER=****102351068723

DISPLAY_SPEND_RATIO (Balance Type Display to Spend Ratio)

Description:	The Display to Spend ratio configured against each balance type used for this service.
Format:	Comma separated list of floating point numbers.
Version:	CCC 6.0.1
Notes:	A ratio of an accounts actual balance to what is used within a rating system.
Example:	DISPLAY_SPEND_RATIO=1.0,2.0,1.0

DISTRIBUTOR_CHANNEL (voucher details)

Description:	Distributor of the voucher.
Format:	String
Version:	CCC 12.0.1
Notes:	You can use a maximum of 50 characters.
Example:	DISTRIBUTOR_CHANNEL=Channel1

DOMAIN_MIGRATION

Description:	Indicates that the wallet was migrated successfully.
Format:	String
Version:	CCC 6.0.0
Notes:	This value will always be 'Y' for the EDR record.
Example:	DOMAIN_MIGRATION=Y

DURATION (call length)

Description:	The actual call length ignoring any grace period that may result in the call not being charged.
Format:	Integer or Float
Version:	CCC 6.0.0
Notes:	If a CAMEL Phase 2 or Phase 3 type switch is being used, this field will be in float format to two decimal places (seconds and deci-seconds). If a Nokia type switch is being used the field will be in integer format (seconds).
Example:	Nokia switch is whole seconds DURATION=120.00 CAMEL Phase 2 or Phase 3 type switch is decimal seconds DURATION=162.30

DURATION_CHARGED

Description:	The actual charged duration or charged volume for the session.
Format:	Integer
Version:	CCC 6.0.0

Notes:	<p>The value output is the duration of the session rounded up to the nearest quanta, based on the billing resolution (the minimum unit length for billing calls) and the minimum session length value (must be a multiple of the billing resolution). For example, if the minimum session length is 60 seconds, and the billing resolution is 10 seconds, then:</p> <ul style="list-style-type: none"> For a session that lasts for 20 seconds, the charged duration will be 60 seconds. In the EDR, the DURATION field is set to 20, and the DURATION_CHARGED field is set to 60 (the minimum session length). For a session that lasts for 73 seconds, the charged duration will be 80 seconds. In the EDR, the DURATION field is set to 73, and the DURATION_CHARGED field is set to 80 (the actual session length rounded up to the nearest 10 seconds).
Example:	DURATION_CHARGED=60

DURATION_DELTA

Description:	This field will record the session duration in the midsession EDR for the call (delta duration between previous session EDR and current EDR).
Format:	Integer or Float
Version:	CCC 12.0.6
Notes:	If a CAMEL Phase 2 or Phase 3 type switch is being used, this field will be in float format to two decimal places (seconds and deci-seconds).
Example:	DURATION_DELTA=120.00

END_CALL_REASON

Description:	A number that specifies the reason that the call terminated:																																				
	<table border="1"> <thead> <tr> <th>N o.</th> <th>Description</th> </tr> </thead> <tbody> <tr> <td>1</td> <td>There was a problem playing the pre-call low balance warning</td> </tr> <tr> <td>2</td> <td>Abort flag set on ACR, where ACR is received before event report</td> </tr> <tr> <td>3</td> <td>Abort status for AT before ACR received</td> </tr> <tr> <td>4</td> <td>Abort flag set on ACR, where ACR is received after event report</td> </tr> <tr> <td>5</td> <td>Abort status for AT after ACR received</td> </tr> <tr> <td>6</td> <td>Abort status for AT while waiting for BE response</td> </tr> <tr> <td>7</td> <td>ACR indicated switch released call on timer expiry</td> </tr> <tr> <td>8</td> <td>Last reservation failed, and no funds held back</td> </tr> <tr> <td>9</td> <td>Last reservation failed, and no funds held back (disconnect leg supported by switch)</td> </tr> <tr> <td>10</td> <td>Called party busy, no charge</td> </tr> <tr> <td>11</td> <td>Failed to route call, no charge</td> </tr> <tr> <td>12</td> <td>Calling party abandoned prior to called party answer, no charge</td> </tr> <tr> <td>13</td> <td>Called party did not answer, no charge</td> </tr> <tr> <td>14</td> <td>Calling party hung up</td> </tr> <tr> <td>15</td> <td>Called party hung up</td> </tr> <tr> <td>16</td> <td>Calling party hung up but last ACR indicated call still active</td> </tr> <tr> <td>17</td> <td>Called party hung up but last ACR indicated call still active</td> </tr> </tbody> </table>	N o.	Description	1	There was a problem playing the pre-call low balance warning	2	Abort flag set on ACR, where ACR is received before event report	3	Abort status for AT before ACR received	4	Abort flag set on ACR, where ACR is received after event report	5	Abort status for AT after ACR received	6	Abort status for AT while waiting for BE response	7	ACR indicated switch released call on timer expiry	8	Last reservation failed, and no funds held back	9	Last reservation failed, and no funds held back (disconnect leg supported by switch)	10	Called party busy, no charge	11	Failed to route call, no charge	12	Calling party abandoned prior to called party answer, no charge	13	Called party did not answer, no charge	14	Calling party hung up	15	Called party hung up	16	Calling party hung up but last ACR indicated call still active	17	Called party hung up but last ACR indicated call still active
N o.	Description																																				
1	There was a problem playing the pre-call low balance warning																																				
2	Abort flag set on ACR, where ACR is received before event report																																				
3	Abort status for AT before ACR received																																				
4	Abort flag set on ACR, where ACR is received after event report																																				
5	Abort status for AT after ACR received																																				
6	Abort status for AT while waiting for BE response																																				
7	ACR indicated switch released call on timer expiry																																				
8	Last reservation failed, and no funds held back																																				
9	Last reservation failed, and no funds held back (disconnect leg supported by switch)																																				
10	Called party busy, no charge																																				
11	Failed to route call, no charge																																				
12	Calling party abandoned prior to called party answer, no charge																																				
13	Called party did not answer, no charge																																				
14	Calling party hung up																																				
15	Called party hung up																																				
16	Calling party hung up but last ACR indicated call still active																																				
17	Called party hung up but last ACR indicated call still active																																				
Format:	Integer																																				
Version:	CCC 6.0.0																																				
Example:	END_CALL_REASON=12																																				

EVENT_CLASS (list of classes used)

Description:	A list of event classes that were used for this call.
Format:	String(s)
Version:	CCC 6.0.0
Notes:	
Example:	

EVENT_COST (for each named event)

Description:	A list of event costs (in small currency) that correspond to each named event that is specified in the EVENT_NAME field of this EDR record.
Format:	Integer(s)
Version:	CCC 6.0.0

Notes:	<ul style="list-style-type: none"> Each event cost will have an associated event count as specified by the EVENT_COUNT field and an associated discount (in 1/10000's of a percent) as specified by the DISCOUNT field for the EDR record. This field is determined by the tariff associated with this named event and is not fixed for a specific account. This field needs to be associated with the EVENT_COUNT and DISCOUNT fields to determine the cost of the call.
Example:	

EVENT_COUNT (for each named event)

Description:	A list of event counts that correspond to each named event that is specified in the EVENT_NAME field of this EDR record.
Format:	Integer(s)
Version:	CCC 6.0.0
Notes:	
Example:	

EVENT_NAME (list used for this call)

Description:	A list of event names that were used for this call.
Format:	String(s)
Version:	CCC 6.0.0
Notes:	
Example:	

EVENT_TIME_COST (for a named event)

Description:	Shows the time-cost of a named event, which will be debited against a time balance.
Format:	Integer
Version:	CCC 6.0.0
Notes:	This field is only valid for systems running CCC version 6.0.0 or greater, for all other systems this field will always be shown as "0".
Example:	

EXCEEDED_BALANCE_NAMES

Description:	The names that correspond to the IDs in the EXCEEDED_BALANCE_TYPES field.
Format:	String
Version:	CCC 6.0.0
Notes:	
Example:	EXCEEDED_BALANCE_NAMES=Roam Zone 3 MB

EXCEEDED_BALANCE_TYPES

Description:	The balance types that exceeded a maximum limit on recharge.
Format:	Integer
Version:	CCC 6.0.0
Notes:	
Example:	EXCEEDED_BALANCE_TYPES=1103

EXCEEDED_VALUES

Description:	The unused balance value exceeding the configured maximum balance for the balance types.
Format:	Integer
Version:	CCC 6.0.0
Notes:	The values above the maximum limits are displayed as negative values.
Example:	EXCEEDED_VALUES=-10000

EXPIRED_WALLET (ID of expired wallet)

Description:	If the balance has expired due to a wallet expiry, then this field will contain the ID of the account's wallet if configured to do so.
Format:	Integer
Version:	CCC 6.0.0
Notes:	This is an internal wallet reference only (ccs_acct.BE_ACCT_ID or be_wallet.ID).
Example:	

EXPIRY_DATE (for a credit card)

Description:	The date when the credit card expires, and that is specified on the credit card.
Format:	String
Version:	CCC 6.0.0
Notes:	The expiry date has the following format, <i>MMYY</i> .
Example:	EXPIRY_DATE=0814

FCA (final call address)

Description:	The final called address (FCA) for this call
Format:	String
Version:	CCC 6.0.0
Notes:	This information is provided when the call info record is received from the switch through the UATB node.
Example:	FCA=01473254338

FAILED_BALANCE_NAMES

Description:	The names that correspond to the IDs in the FAILED_BALANCE_TYPES field.
Format:	String
Version:	CCC 6.0.0
Notes:	
Example:	FAILED_BALANCE_NAMES=Roam Zone 3 MB

FAILED_BALANCE_TYPES

Description:	The balance type that failed to recharge.
Format:	Integer
Version:	CCC 6.0.0
Notes:	If the recharge exceed the maximum value configured for any of the balance types, it will result in failure and the balance will not be updated or recharged. The balance types causing the failure will be recorded in the FAILED_BALANCE_TYPES.
Example:	FAILED_BALANCE_TYPES=1103

FREE_TEXT_FIELD_1 (voucher details)

Description:	Field for capturing business process information.
Format:	String
Version:	CCC 12.0.1
Notes:	You can use a maximum of 50 characters.
Example:	FREE_TEXT_FIELD_1=Freetext1

FREE_TEXT_FIELD_2 (voucher details)

Description:	Field for capturing business process information.
Format:	String
Version:	CCC 12.0.1
Notes:	You can use a maximum of 50 characters.
Example:	FREE_TEXT_FIELD_1=Freetext2

FREE_TEXT_FIELD_3 (voucher details)

Description:	Field for capturing business process information.
Format:	String
Version:	CCC 12.0.1
Notes:	You can use a maximum of 50 characters.
Example:	FREE_TEXT_FIELD_1=Freetext2

HOST (initiating credit transfer)

Description:	Name of the host that initiated the credit transfer.
Format:	String
Version:	CCC 6.0.0
Notes:	
Example:	

IGNORE_BARRED (ignore numbers in call barring list)

Description:	Flag to determine whether or not to ignore the numbers specified in the call barring list.
Format:	Integer
Version:	CCC 6.0.0
Notes:	
Example:	

LAST_RECORD_DATE

Description:	This field will record the last commit time in the midsession EDR which will be the start time of the current EDR.
Format:	Date
Version:	CCC 12.0.6
Notes:	
Example:	LAST_RECORD_DATE=20230517062312

LENGTHS (rate durations)

Description:	A list of rate durations (in seconds) that exist for this call. This field is determined by the tariff associated with this call and is not fixed for a specific account.
Format:	Float (two decimal places)
Version:	CCC 6.0.0
Notes:	Every duration will have an associated rate (in small currency) as specified by the RATES field for the EDR record.
Example:	LENGTHS=2810.00 LENGTHS=60.00,60.00,90.00,0.00

LENGTHS (rate durations) -1end duration

Description:	<p>A list of rate durations (in seconds) that exist for this call. This field is determined by the tariff associated with this call and is not fixed for a specific account.</p> <p>A LENGTHS tag value of -1 will be used for the final rate duration of the call. This means that this rate duration is undefined and the rate will be used for the remainder of the call.</p> <p>If a call uses a rate with a single charge period, then this will be shown in the EDR as LENGTHS=-1.</p>
---------------------	--

Format:	Float (two decimal places)
Version:	CCC 6.0.0
Notes:	Every duration will have an associated rate (in small currency) as specified by the RATES field for the EDR record.
Example:	LENGTHS=-1 LENGTHS=60.00,60.00,90.00,-1

LENGTHS (rate durations) - mid call rate change

Description:	<p>A list of rate durations (in seconds) that exist for this call. This field is determined by the tariff associated with this call and is not fixed for a specific account.</p> <p>A LENGTHS tag value of -1 will be used for the final rate duration of the call. This means that this rate duration is undefined and the rate will be used for the remainder of the call.</p> <p>If a call uses a rate with a single charge period, then this will be shown in the EDR as LENGTHS=-1.</p> <p>For calls with mid call rate changes, the lengths will be broken down by tariff plan ID and time stamp for each rate change. The tariff plan ID, time stamp and lengths are colon separated.</p>
Format:	Float (two decimal places)
Version:	CCC 6.0.0
Notes:	Every duration will have an associated rate (in small currency) as specified by the RATES field for the EDR record.
Example:	<p>Single call rate: LENGTHS=-1</p> <p>Mid call rate change: LENGTHS=Trff Plan ID1:<TimeStamp>:120,-1;Trff Plan ID2:<TimeStamp>:120,-1</p>

LOCADD (additional configuration prefixes)

Description:	The CLI field with additional configuration prefixes added.
Format:	String
Version:	CCC 6.0.0
Notes:	
Example:	LOCADD=E771231473289900

MAX_CHARGE (for this call)

Description:	The maximum charge for this call.
Format:	Integer
Version:	CCC 6.0.0
Notes:	This value will be taken from either the maximum charge for the tariff associated with this call or if a discount (holiday or weekly) is applied, then the maximum charge for the associated discount.

Example:	MAX_CHARGE=500
-----------------	----------------

MAX_CHARGE (for this call) - mid call rate change

Description:	The maximum charge for this call. For calls with mid call rate changes, the maximum charge will also be broken down by tariff plan ID and time stamp for the start of each rate change. The tariff plan ID, time stamp and maximum charge are colon separated.
Format:	Integer
Version:	CCC 6.0.0
Notes:	This value will be taken from either the maximum charge for the tariff associated with this call or if a discount (holiday or weekly) is applied, then the maximum charge for the associated discount.
Example:	Single call rate: MAX_CHARGE=500
	Mid call rate change: MAX_CHARGE=Tariff Plan ID1:Time Stamp:100;Tariff Plan ID2:Time Stamp:100

MAX_CONCURRENT (maximum concurrent accesses allowed)

Description:	The number of maximum concurrent accesses allowed for this account.
Format:	Integer
Version:	CCC 6.0.0
Notes:	
Example:	MAX_CONCURRENT=1

MFILE (name)

Description:	The date/time stamp MFile file name that the rating information for the call is within.
Format:	String
Version:	CCC 6.0.0
Notes:	
Example:	MFILE=20100602203530

MID_SESSION

Description:	This tag is added to indicate a partial, mid call produced EDR.
Format:	String
Version:	CCC 6.0.0

Notes:	Only ever added when true, for false (or the final complete EDR) the tag is omitted. Partial EDRs may be created when the commit volume threshold (Rating Management > Reservation Config > Add/Edit Reservation Config panel) is enabled.
Example:	MID_SESSION=TRUE

MSISDN (account calling number)

Description:	The calling line identifier (calling number) of the account that changed during the call's processing.
Format:	String
Version:	CCC 6.0.0
Notes:	<ul style="list-style-type: none"> When the ccsCDRLoader plugin is installed on the SMS, this tag will be present. Value is taken from ccs_acct_reference.CLI. EDR records associated with each wallet expiry contain the MSISDN and product types of all affected subscribers.
Example 1:	Standard format: MSISDN=1394111111
Example 2:	<p>Wallet expiry format:</p> <p>A user may have a mobile and a data card - each with its own SIM. The mobile and data cards are each represented as subscriber records, but they share a single wallet.</p> <p>If the:</p> <ul style="list-style-type: none"> MSISDN of the mobile card is 01234 and of the data card is 01235 product types are 1 (mobile card - Prepaid Voice) and 2 (data card - Prepaid Data), <p>then the expiry EDR would contain the following fields:</p> <p>MSISDN=01234 , 01235</p> <p>Account_Type=1 , 2</p>

MSISDN (subscriber ids)

Description:	The calling line identifier (calling number) for each subscriber who is authorized to use the credit card.
Format:	String
Version:	CCC 6.0.0
Notes:	
Example:	MSISDN=1394111111 , 1395111111

NACK (freeform recharge list)

Description:	The internal failure reason code for the failed call.
Format:	String
Version:	CCC 6.0.0

Notes:	Valid failure codes are:	
	BDVR	Bad recharge attempt (duplicate or invalid balance type, no expiration, or cannot recharge terminated wallet)
	NRCH	Balance not chargeable (single use wallet)
	SNIL	State not in list (when wallet state is invalid)
	WDIS	Wallet's current state is not valid. Wallet will be in one of the following states - 'F' (Frozen), 'T' (Terminated) or 'S' (Suspended)
Example:	NACK=WDIS	

NACK (long list of codes)

Description:	The internal failure reason code for the failed call.	
Format:	String	
Version:	CCC 6.0.0	
Notes:	Valid failure codes are:	
	INSF	Insufficient funds
	CRIS	Calling and/or called number restricted
	NACC	No account type entry defined for this tariff
	NGEO	No geography set defined for this tariff
	NRAT	No rate information defined for this tariff
	NBIL	No billing periods defined for this tariff
	NCAS	No balance type cascade defined for this tariff
	NTAR	No tariff plan selector defined for this tariff
	MAXL	The maximum length defined for this account has been exceeded
	WDIS	Wallet's current state is not valid. Wallet will be in one of the following states - 'F' (Frozen), 'T' (Terminated) or 'S' (Suspended)
	TMNY	The maximum number of concurrent accesses allowed defined for this account has been exceeded
	Example:	

NACK (short list of codes)

Description:	The internal failure reason code for the failed call.	
Format:	String	
Version:	CCC 6.0.0	

Notes:	Valid failure codes are:	
	INSF	Insufficient funds.
	NENA	Named event not allowed. No row in CCS_PRODUCT_CATALOGUE or CCS_PRODUCT_CATALOGUE_EVENTS for requested ProductType/EventClass/EventName.
	NBTY	No balance type.
	WDIS	Wallet's current state is not valid. Wallet will be in one of the following states - 'F' (Frozen), 'T' (Terminated) or 'S' (Suspended).
	TMNY	The maximum number of concurrent accesses defined for this account has been exceeded.
Example:	NACK=INSF	

NAME_ON_CARD (for a credit card)

Description:	The name of the credit card holder as it appears on the card.
Format:	String
Version:	CCC 6.0.0
Notes:	
Example:	NAME_ON_CARD=TOM SMITH

NEW_ACCOUNT (ID of account type)

Description:	The ID of the account type (product type) for this account after a product type swap.
Format:	Integer
Version:	CCC 6.0.0
Notes:	
Example:	

NEW_ACCT_EXPIRY (date after account deleted)

Description:	The expiry date for the account after the update.
Format:	Date
Version:	CCC 6.0.0
Notes:	This will always be '0' indicating no expiry.
Example:	NEW_ACCT_EXPIRY=0

NEW_ACCT_EXPIRY (date after update)

Description:	The expiry date for the account after the update.
Format:	Date (yyyymmddhhmmss format)
Version:	CCC 6.0.0
Notes:	'0' or blank indicates that the expiry date for the account is not set - it will never expire.
Example:	NEW_ACCT_EXPIRY=0

NEW_ACCT_EXPIRY (date after recharge)

Description:	The current wallet expiry date after a successful voucher recharge.
Format:	Date (yyyymmddhhmmss format)
Version:	CCC 6.0.0
Notes:	
Example:	NEW_ACCT_EXPIRY=20071206080259

NEW_ACCT_STATE (always active - A)

Description:	The account state after the call.
Format:	String
Version:	CCC 6.0.0
Notes:	This value will always be 'A' (Active) for this EDR record.
Example:	NEW_ACCT_STATE=A

NEW_ACCT_STATE (always frozen - F)

Description:	The account state after the recharge.
Format:	String
Version:	CCC 6.0.0
Notes:	This value will always be 'F' (Frozen).
Example:	NEW_ACCT_STATE=F

NEW_ACCT_STATE (always preuse - P)

Description:	The account state when the update has completed.
Format:	String
Version:	CCC 6.0.0
Notes:	This value will always be 'P' (PreUse).
Example:	NEW_ACCT_STATE=P

NEW_ACCT_STATE (always terminated - T)

Description:	The account state after the recharge.
Format:	String
Version:	CCC 6.0.0
Notes:	This value will always be 'T' (Terminated) for this EDR record.
Example:	NEW_ACCT_STATE=T

NEW_ACCT_STATE (after update)

Description:	The account state after the update.
Format:	String

Version:	CCC 6.0.0
Notes:	Valid values are: <ul style="list-style-type: none"> • 'P' (PreUse) • 'A' (Active) • 'D' (Dormant) • 'F' (Frozen) • 'S' (Suspended) • 'T' (Terminated)
Example:	NEW_ACCT_STATE=A

NEW_ACCT_TYPE (ID of account after recharge)

Description:	The ID of the account type (product type) for this account following the recharge.
Format:	Integer.
Version:	CCC 6.0.0
Notes:	This is an internal account type reference only (ccs_acct_type.ID).
Example:	

NEW_ACCT_TYPE (prod type swap)

Description:	The ID of the account type (product type) for this account after the product type swap.
Format:	Integer
Version:	CCC 6.0.0
Notes:	This is an internal account type reference only (ccs_acct_type.ID).
Example:	

NEW_ACTIVE_SVC (account type)

Description:	New active account type.
Format:	String
Version:	CCC 6.0.0
Notes:	
Example:	NEW_ACTIVE_SVC=F

NEW_BALANCE_EXPIRIES (date after balance update)

Description:	A list of the expiry dates for each balance type ID displayed in the BALANCE_TYPES field of the EDR record after the update.
Format:	List of date(s) (yyyymmddhhmmss format)
Version:	CCC 6.0.0
Notes:	<ul style="list-style-type: none"> • '0' indicates that the expiry date for this balance is not set - it will never expire. • If the balance has an expiry date set then it will be displayed regardless of whether it is changed during the update.
Example:	NEW_BALANCE_EXPIRIES=0

NEW_BALANCE_EXPIRIES (dates after voucher recharge)

Description:	A list of the expiry dates for each balance type ID displayed in the BALANCE_TYPES field of the EDR record after the recharge.
Format:	List of date(s) (yyyymmddhhmmss format)
Version:	CCC 6.0.0
Notes:	<ul style="list-style-type: none"> An empty string indicates that the expiry date for this balance is not set - it will never expire. If the balance has an expiry date set then it will be displayed.
Example:	NEW_BALANCE_EXPIRIES=0

NEW_BARRED_LIST (of call barring numbers)

Description:	Comma separated list of call barring numbers following the update.
Format:	List
Version:	CCC 6.0.0
Notes:	
Example:	NEW_BARRED_LIST=03200000001,03200000002,03200000003,03200000004,03200000005

NEW_CHARGE_STATE (periodic charge subscription state)

Description:	The state the periodic charge subscription was changed to.
Format:	String
Version:	CCC 6.0.0
Notes:	
Example:	NEW_CHARGE_STATE=SUBSCRIBED

NEW_FD (friends destination number)

Description:	New friends destination number.
Format:	String
Version:	CCC 6.0.0
Notes:	
Example:	NEW_FD=22

NEW_FF (list of friends and family numbers)

Description:	New list of friends and family numbers.
Format:	List
Version:	CCC 6.0.0
Notes:	
Example:	NEW_FF=488122346,77777776

NEW_LAST_USE (date last used)

Description:	The date of last use.
Format:	Date (yyyymmddhhmmss format)
Version:	CCC 6.0.0
Notes:	
Example:	NEW_LAST_USE=0

NEW_WLC_PERIOD (after update)

Description:	Identifies the new period in the wallet life cycle.
Format:	Integer
Version:	CCC 6.0.0
Notes:	
Example:	NEW_WLC_PERIOD=2

NEW_WLC_PLAN (Id)

Description:	The internal ID of the new wallet life cycle plan.
Format:	Integer
Version:	CCC 6.0.0
Notes:	
Example:	NEW_WLC_PLAN=2

NUMBER (voucher number)

Description:	Indicates the voucher number.
Format:	String
Version:	CCC 6.0.1
Notes:	
Example:	NUMBER=00000250

OGEO_ID (originating geo node id)

Description:	The voice call originating geographic node ID.
Format:	Integer
Version:	CCC 6.0.0
Notes:	
Example:	OGEO=13

OLD_ACCOUNT (ID of account type)

Description:	The ID of the account type (product type) for this account prior to a product type swap.
---------------------	--

Format:	Integer
Version:	CCC 6.0.0
Notes:	
Example:	

OLD_ACCT_EXPIRY (dates before update)

Description:	The expiry date for the account prior to the update.
Format:	Date (yyyymmddhhmmss format)
Version:	CCC 6.0.0
Notes:	'0' indicates that the expiry date for the account was not set - it would have never expired.
Example:	OLD_ACCT_EXPIRY=20080901185959

OLD_ACCT_EXPIRY (date before recharge)

Description:	The wallet expiry date before a successful voucher recharge.
Format:	Date (yyyymmddhhmmss format)
Version:	CCC 6.0.0
Notes:	'0' indicates that the expiry date for the account was not set - it would have never expired.
Example:	OLD_ACCT_EXPIRY=20070904083550

OLD_ACCT_STATE (always active - A)

Description:	The account state prior to the recharge.
Format:	String
Version:	CCC 6.0.0
Notes:	This value will always be 'A' (Active).
Example:	OLD_ACCT_STATE=A

OLD_ACCT_STATE (before update)

Description:	The account state prior to the update.
Format:	String
Version:	CCC 6.0.0
Notes:	Valid values are: <ul style="list-style-type: none"> • 'P' (PreUse) • 'D' (Dormant) • 'F' (Frozen) • 'S' (Suspended) • 'T' (Terminated)
Example:	OLD_ACCT_STATE=P

OLD_ACCT_STATE (pre-call)

Description:	The account state prior to the call.
Format:	String
Version:	CCC 6.0.0
Notes:	Valid values are: <ul style="list-style-type: none"> • P (PreUse) • D (Dormant)
Example:	OLD_ACCT_STATE=D

OLD_ACCT_STATE (P or D before update)

Description:	The account state prior to the update.
Format:	String
Version:	CCC 6.0.0
Notes:	Valid values are: <ul style="list-style-type: none"> • 'P' (PreUse) • 'D' (Dormant)
Example:	OLD_ACCT_STATE=P

OLD_ACCT_TYPE (ID of account before recharge)

Description:	The ID of the account type (product type) for this account prior to the recharge.
Format:	Integer.
Version:	CCC 6.0.0
Notes:	
Example:	

OLD_ACCT_TYPE (prod type swap)

Description:	The ID of the account type (product type) for this account prior to the product type swap.
Format:	Integer.
Version:	CCC 6.0.0
Notes:	
Example:	

OLD_ACTIVE_SVC (account type)

Description:	Old active account type.
Format:	String
Version:	CCC 6.0.0
Notes:	
Example:	OLD_ACTIVE_SVC=D

OLD_BALANCE_EXPIRIES (dates before balance update)

Description:	A list of the expiry dates for each balance type ID displayed in the BALANCE_TYPES field of the EDR record prior to the update.
Format:	List of date(s) (yyyymmddhhmmss format)
Version:	CCC 6.0.0
Notes:	<ul style="list-style-type: none"> An empty string indicates that the expiry date for this balance is not set - it will never expire. If the balance has an expiry date set then it will be displayed regardless of whether it is changed during the update.
Example:	OLD_BALANCE_EXPIRIES=0

OLD_BALANCE_EXPIRIES (dates before voucher recharge)

Description:	A list of the expiry dates for each balance type ID displayed in the BALANCE_TYPES field of the EDR record prior to the recharge.
Format:	list of date(s) (yyyymmddhhmmss format)
Version:	CCC 6.0.0
Notes:	<ul style="list-style-type: none"> '0' indicates that the expiry date for this balance is not set - it will never expire. If the balance has an expiry date set then it will be displayed.
Example:	OLD_BALANCE_EXPIRIES=0

OLD_BARRED_LIST (of call barring numbers)

Description:	The list of call barring numbers prior to the update.
Format:	List
Version:	CCC 6.0.0
Notes:	
Example:	OLD_BARRED_LIST=

OLD_CHARGE_EXPIRY (periodic charge expiry date changes)

Description:	The expiry date for the periodic charge before it changed.
Format:	Date (yyyymmddhhmmss format)
Version:	CCC 6.0.0
Notes:	
Example:	OLD_CHARGE_EXPIRY=20101222221708

OLD_CHARGE_STATE (periodic charge subscription state)

Description:	The state the periodic charge was in before it was changed.
Format:	String
Version:	CCC 6.0.0
Notes:	
Example:	OLD_CHARGE_STATE=SUBSCRIBED

OLD_FD (friends destination number)

Description:	Old friends destination number.
Format:	String
Version:	CCC 6.0.0
Notes:	
Example:	OLD_FD=44

OLD_FF (list of friends and family numbers)

Description:	The old list of friends and family numbers.
Format:	List
Version:	CCC 6.0.0
Notes:	
Example:	OLD_FF=488122346

OLD_WLC_PERIOD (before update)

Description:	The internal id of the current period in the wallet life cycle.
Format:	Integer
Version:	CCC 6.0.0
Notes:	
Example:	OLD_WLC_PERIOD=1

OLD_WLC_PLAN (Id)

Description:	The internal id of the current wallet life cycle plan.
Format:	Integer
Version:	CCC 6.0.0
Notes:	
Example:	OLD_WLC_PLAN=1

OPERATOR_RELEASED (commit/revoke reservation)

Description:	Indicator that the commit or revoke was done by an operator as identified by the USER tag.
Format:	Integer
Version:	CCC 6.0.0
Notes:	When present, will always be 1.
Example:	OPERATOR_RELEASED=1

OVERDRAWN_AMOUNT (take Balance Negative)

Description:	The negative portion of the amount charged from the last element in the cascade that the user has in their wallet.
Format:	Integer
Version:	CCC 6.0.0
Notes:	This tag is used when: <ul style="list-style-type: none"> The NSF policy is set to takeBalanceNegative There were not sufficient funds The negative portion of the amount charged is the value for this tag.
Example:	OVERDRAWN_AMOUNT=1234

OVERRIDDEN_TARIFF_PLAN (ID)

Description:	The ID of the tariff plan that is being overridden for the current call through the CUG feature node, or the Tariff Plan Override node.
Format:	Integer
Version:	CCC 6.0.0
Notes:	
Example:	

PC_TYPE (periodic charge type)

Description:	The type of periodic charge.
Format:	String
Version:	CCC 6.0.0
Notes:	The possible values are: <ul style="list-style-type: none"> SUB – Subscribe or ReSubscribe CHRG – Charge Alignment UNSUB – Unsubscribe TERM – Terminate
Example:	PC_TYPE=CHRG

PI (logon name and IP address)

Description:	The PI logon name and IP address of the operator that performed the recharge.
Format:	String (<i>PIlogonNameATOperator'sIPAddress</i> format)
Version:	CCC 6.0.0
Notes:	
Example:	PI= adminAT192.168.25.106

PORTED (name of porting carrier)

Description:	The name of the carrier that ported this call.
Format:	String

Version:	CCC 6.0.0
Notes:	<ul style="list-style-type: none"> The MNP software provides a ccsCDRLoaderPlugin on the SMS. This plug-in will determine if the call has been ported during processing. If so, then the CLI and TN fields will have the MNP prefix stripped and the PORTED field will be added.
Example:	

PRO_RATE (periodic charge subscription)

Description:	The percentage value a periodic charge subscription has been pro-rated at.
Format:	Integer
Version:	CCC 6.0.0
Notes:	<p>This value is the relative percentage, where:</p> <ul style="list-style-type: none"> 0 represents the full subscription charge. < 0 indicates an increased charge (period has been extended) and > 0 indicates a reduced charge (for less than the full period).
Example:	PRO_RATE=27

PROVISIONING_DATE (voucher details)

Description:	Date on which the voucher is created.
Format:	Date (yyyymmddhhmmss format)
Version:	CCC 12.0.1
Notes:	
Example:	PROVISIONING_DATE=20180313091814

PURCHASING_ACCT_ID (purchasing wallet ID)

Description:	Purchasing wallet ID.
Format:	Integer
Version:	CCC 6.0.0
Notes:	From ccs_acct.BE_ACCT_ID.
Example:	

PURCHASING_MSISDN (purchasing CLI)

Description:	Purchasing CLI
Format:	String
Version:	CCC 6.0.0
Notes:	From ccs_acct_reference.CLI
Example:	

RATES (rated calls)

Description:	A list of rates that exist for this call. For multi tariff rated calls this is a comma separated list of the service ID (as listed in BALANCE_TYPES) and the list of rates for each tariff in the rate. The service ID and list of rates is colon separated.
Format:	Integer(s) or Float
Version:	CCC 6.0.0
Notes:	<ul style="list-style-type: none"> Each rate will have an associated length (in seconds) as specified by the LENGTHS field and an associated discount (in 1/10000's of a percent) as specified by the DISCOUNTS field for the EDR record. This field is determined by the tariff associated with this call and is not fixed for a specific account. This field needs to be associated with the LENGTHS, DURATION, MAX_CHARGE and DISCOUNTS fields to determine the cost of the call. Float type if time rates (up to five decimal places), Integer type if currency rates
Example:	Single tariff: RATES=60
	Multi tariff: RATES=Service Id 1:10,20,30,30,Service ID 2:5,5,5,5
	Time rate: RATES=9.66667

RATES (rated calls) - mid call rate change

Description:	A list of rates that exist for this call. For multi tariff rated calls this is a comma separated list of the service ID (as listed in BALANCE_TYPES) and the list of rates for each tariff in the rate. The service ID and list of rates is colon separated. For calls with mid call rate changes, rates will also be broken down by tariff plan ID and the time stamp for each rate change. The tariff plan ID, time stamp and rates are colon separated. For multi tariff rated calls with mid call rate changes, then the service ID is included as well.
Format:	Integer(s) or float
Version:	CCC 6.0.0
Notes:	<ul style="list-style-type: none"> Each rate will have an associated length (in seconds) as specified by the LENGTHS field and an associated discount (in 1/10000's of a percent) as specified by the DISCOUNTS field for the EDR record. This field is determined by the tariff associated with this call and is not fixed for a specific account. This field needs to be associated with the LENGTHS, DURATION, MAX_CHARGE and DISCOUNTS fields to determine the cost of the call. Float type if time rates (up to five decimal places), Integer type if currency rates

Example:	Single tariff: RATES=60
	Multi tariff: RATES=Service Id 1:10,20,30,30,Service ID 2:5,5,5,5
	Time rate: RATES=9.66667
	Single tariff mid call rate change: RATES=Tariff Plan ID1:Time Stamp:10,20,30;Tariff Plan ID2:Time Stamp:10,20,30
	Multi tariff mid call rate change: RATES=Tariff Plan ID1:Time Stamp:Service ID1:10,20,30:Service ID2:10,15,20;Tariff Plan ID2:Time Stamp:Service ID1:10,20,30:Service ID2:10,15,20

REASON (change reason)

Description:	The reason that is entered by the operator for updating a subscriber's financial status; for example by updating their wallet balance, or credit card details.
Format:	String
Version:	CCC 6.0.0
Notes:	The change reason can be up to 200 characters long.
Example:	REASON="Add new credit card details"

RECIPIENT_ACCT_ID (receiving wallet ID)

Description:	Recipient wallet ID.
Format:	Integer
Version:	CCC 6.0.0
Notes:	From ccs_acct.BE_ACCT_ID.
Example:	RECIPIENT_ACCT_ID=1021

RECIPIENT_MSISDN (receiving CLI)

Description:	The recipient CLI.
Format:	String
Version:	CCC 6.0.0
Notes:	From ccs_acct_reference.CLI.
Example:	RECIPIENT_MSISDN=11012

RECORD_DATE (date edr created)

Description:	The date of the EDR record creation.
Format:	Date (yyyymmddhhmmss format)
Version:	CCC 6.0.0
Notes:	
Example:	RECORD_DATE=20040803121758

REDEEMING_ACCT_REF (ID of account)

Description:	The reference ID of the account that redeemed the voucher.
Format:	Integer
Version:	CCC 6.0.0
Notes:	This is an internal account reference only (ccs_acct_reference.ID).
Example:	REDEEMING_ACCT_REF=61

REDEEMING_ACCT_TYPE (name of account type)

Description:	The name of the redeeming account type (product type) for this voucher recharge.
Format:	String
Version:	CCC 6.0.0
Notes:	
Example:	

REFERENCE (credit card reference, always cc)

Description:	A reference string for the transaction generated by the system.
Format:	String
Version:	CCC 6.0.0
Notes:	There will always be a 'CC' prefix on this reference to indicate the reference was created as a result of a credit card recharge through the IVR where the PI is being used to credit the account.
Example:	REFERENCE=CC040804028091

REFERENCE (operator freeform)

Description:	A freeform reference string entered by the operator who performed the recharge.
Format:	String
Version:	CCC 6.0.0
Notes:	
Example:	REFERENCE=FreeForm Recharge

REFERENCE (operator freeform)

Description:	The reference text provided by the caller of the web service.
Format:	String
Version:	CCC 6.0.0
Notes:	
Example:	REFERENCE=REF125

REFERENCE (OSA Bonus)

Description:	The bonus reference used in conjunction with the bonus type to determine the applicable bonus to be applied to the value when crediting the subscriber's wallet. A match will be done against the configured bonus in the database using the CCS_BONUS_TYPE.component column.
Format:	String
Version:	CCC 6.0.0
Notes:	
Example:	REFERENCE=Osa Bonus

REFERENCE (from pi reference)

Description:	A freeform reference string taken from the PI REFERENCE field.
Format:	String
Version:	CCC 6.0.0
Notes:	This is the reference entered by the operator that performed the recharge.
Example:	REFERENCE=PI

REFERENCE (voucher freeform)

Description:	A voucher freeform reference string entered by the operator who performed the recharge.
Format:	String
Version:	CCC 6.0.0
Notes:	
Example:	TAG=

REFERENCE (web site reference - ws)

Description:	A reference string for the transaction generated by the system.
Format:	String
Version:	CCC 6.0.0
Notes:	There will always be a 'WS' prefix on this reference to indicate the transaction was initiated by an external web interface.
Example:	REFERENCE=WS040804028091

RELC (inap release cause)

Description:	The INAP release cause for the call.
Format:	Integer
Version:	CCC 6.0.0
Notes:	
Example:	

RELOAD_BONUS (promotion name)

Description:	The name of the promotional reload bonus being applied to this recharge.
Format:	String
Version:	CCC 6.0.0
Notes:	
Example:	

RELOAD_BONUS_AMOUNT (amount applied)

Description:	The amount of the reload bonus being applied to this recharge.
Format:	Integer
Version:	CCC 6.0.0
Notes:	The account will be credited by the original voucher value + the value of this promotional bonus.
Example:	

RELOAD_BONUS_EXPIRY (date remaining bonus expires)

Description:	The date when the remaining promotional reload bonus amount will expire.
Format:	Date
Version:	CCC 6.0.0
Notes:	'0' indicates that the expiry date for this reload bonus is not set - it will never expire.
Example:	

RELOAD_BONUS_LEFT (bonus amount remaining)

Description:	The amount remaining in the promotional reload bonus balance for this account after the recharge.
Format:	Integer
Version:	CCC 6.0.0
Notes:	
Example:	

REMAINING_CHARGE (partial Charge)

Description:	The amount unable to be charged from the last element in the cascade that the user has in their wallet.
Format:	Integer
Version:	CCC 6.0.0
Notes:	This tag is used when: <ul style="list-style-type: none"> • The NSF policy is set to partialCharge • There were not sufficient funds The amount unable to be charged is the value for this tag.
Example:	REMAINING_CHARGE=1234

RESULT (general cause)

Description:	The failure reason indicating the voucher state.
Format:	String
Version:	CCC 6.0.0
Notes:	Valid failure reasons are: <ul style="list-style-type: none"> • Not Found • Failed Auth • Already Redeemed • Frozen • Batch Unavailable • Batch Stale
Example:	RESULT=Failed Auth

RESULT (frozen or suspended)

Description:	The failure reason indicating the account state.
Format:	String
Version:	CCC 6.0.0
Notes:	Valid failure reasons are: <ul style="list-style-type: none"> • Frozen Wallet • Suspended Wallet
Example:	RESULT=Frozen Wallet

RESULT (pi failure)

Description:	The reason that the recharge failed.
Format:	String
Version:	CCC 6.0.0
Notes:	
Example:	RESULT=Frozen Wallet

RESULT (voucher redemption, always Success)

Description:	The result of the voucher redemption.
Format:	String
Version:	CCC 6.0.0
Notes:	This value will always be 'Success' for the EDR record.
Example:	RESULT=Success

RESULT (web - success)

Description:	The result of the web initiated recharge.
Format:	String
Version:	CCC 6.0.0
Notes:	This value will always be 'Success' for the EDR record.
Example:	RESULT=Success

RETAIL_CHANNEL (voucher details)

Description:	Retailer of the voucher.
Format:	String
Version:	CCC 12.0.1
Notes:	You can use a maximum of 50 characters.
Example:	RETAIL_CHANNEL=channel2

REVERSE_CHARGE (generated by a reverse charge)

Description:	Was this EDR generated by an reverse charge.
Format:	Boolean
Version:	CCC 6.0.0
Notes:	
Example:	

REWARD (ID)

Description:	The ID of the reward applied.
Format:	String
Version:	CCC 6.0.0
Notes:	From CCS_REWARDS.ID.
Example:	REWARD=62

REWARD_AMOUNTS (value of reward)

Description:	A comma-separated list of the value of the reward for the associated balance in REWARD_TYPES.
---------------------	---

Format:	String
Version:	CCC 6.0.0
Notes:	From CCS_MB_VOUCHER.VALUE.
Example:	REWARD_AMOUNTS=1 , 2

REWARD_CATEGORY

Description:	The value represents the reward category value assigned to the promotion in the SMS UI.
Format:	String
Version:	CCC 6.0.0
Notes:	
Example:	REWARD_CATEGORY=TRACKER_THRESHOLD

REWARD_TYPES (balance types getting reward)

Description:	A comma-separated list of one or more balance type ID's on which the reward has been applied.
Format:	String
Version:	CCC 6.0.0
Notes:	From CCS_MB_VOUCHER.BALANCE_TYPE_ID.
Example:	REWARD_TYPES=5 , 2

RNCF (Reservation Not Charged For)

Description:	The difference between the total reservation and the total units consumed (Reservation Not Charged For).
Format:	Integer
Version:	CCC 6.0.0
Notes:	A TIMED_OUT tag will also be present in the EDR.
Example:	RNCF=100

ROAMING_COUNTRY (name)

Description:	The roaming country as determined from the following: <ul style="list-style-type: none"> • CAMEL Originating - the country will be determined from prefix of the CLI field of this EDR record. • Mobile Terminating - the country will be determined from the prefix of the TN field of this EDR record. • USSD Callback - the country will be determined from the prefix of the CLI field of this EDR record.
Format:	String
Version:	CCC 6.0.0
Notes:	The roaming country is taken from the COUNTRY field of the country_codes table using country_codes.CODE as the queried prefix.
Example:	ROAMING_COUNTRY=United Kingdom

ROAMING_TYPE (of call)

Description:	The type of roaming call.
Format:	String
Version:	CCC 6.0.0
Notes:	The type will be one of the following: <ul style="list-style-type: none"> • CAMEL Originating - the value will always be 'CAMEL' • Mobile Terminating - the value will always be 'MT' • USSD Callback - the value will always be 'USSD'
Example:	ROAMING_TYPE=MT

SCENARIO (voucher scenario number)

Description:	The number of the voucher scenario for this voucher recharge.
Format:	Integer
Version:	CCC 6.0.0
Notes:	Not reported if default scenario used.
Example:	SCENARIO=3

SCP_ID (where call originated)

Description:	The unique identifier for the client from where the call originated. The client will be: <ul style="list-style-type: none"> • An SCP for calls • The SMS for updates through the UI.
Format:	Integer
Version:	CCC 6.0.0
Notes:	If the EDR was generated as a result of an account or balance expiry then the SCP_ID will be zero.
Example:	SCP_ID=117692813

SEQUENCE_NUMBER (call identifier)

Description:	This is the unique identifier used internally within the context of the call. This sequence number will be the same across multiple EDR records if the current action results in multiple EDR records being generated, for example, a voucher recharge.
Format:	Integer
Version:	CCC 6.0.0
Notes:	If the EDR was generated as a result of an account or balance expiry, then the SEQUENCE_NUMBER will be zero.
Example:	SEQUENCE_NUMBER=24477838

SERVICE_HANDLE (invoked service handle)

Description:	The service handle invoked by the billing engine that should run the control plan.
Format:	String

Version:	CCC 6.0.0
Notes:	
Example:	SERVICE_HANDLE=CCS_BPL_REWARDS

SERVICE_RESPONSE (from service function)

Description:	The response returned from the service function after the execution of the control plan.
Format:	String
Version:	CCC 6.0.0
Notes:	
Example:	SERVICE_RESPONSE=404 Not Found (INAP 31)

SESSION_SEQUENCE

Description:	This tag is added to all partial EDR records to indicate the generation sequence.
Format:	Integer
Version:	CCC 6.0.0
Notes:	The first EDR in the sequence will have a value of 0 (zero). The tag is not on the final complete EDR. Partial EDRs may be created when the commit volume threshold (Rating Management > Reservation Config > Add or Edit Reservation Config panel) is enabled.
Example:	SESSION_SEQUENCE=1

STATE (of recharge)

Description:	The state of the recharge.
Format:	String
Version:	CCC 6.0.0
Notes:	This value will always be 'verified' for the EDR record.
Example:	STATE=verified

SVC_ID (single tariff rated calls)

Description:	For single tariff rated calls, the service ID description for the CLI-DN. For multi tariff rated calls this is redundant since the information is included in the multi tariff component of the relevant tags (such as COSTS), and should not appear in the EDR record.
Format:	String
Version:	CCC 6.0.0
Notes:	
Example:	SVC_ID=ServiceA

TARIFF_CODE (name)

Description:	The name of the tariff code associated with the CLI_DN or discount, sent to the TCAP interface.
Format:	String
Version:	CCC 6.0.0
Notes:	
Example:	

TCE (ccs time call ended)

Description:	Time the call ended. The time of A-party and B-party disconnect or zero if no connection was made.
Format:	Date (yyyymmddhhmmss format)
Version:	CCC 6.0.0
Notes:	
Example:	TCE=20070423181510

TCS (ccs time call started)

Description:	Time the call started.
Format:	Date (yyyymmddhhmmss format)
Version:	CCC 6.0.0
Notes:	
Example:	TCS=20070423181310

TERMINAL (Network ID)

Description:	Network ID of terminal using screens that generate EDRs.
Format:	String
Version:	CCC 6.0.0
Notes:	
Example:	TERMINAL=192.168.25.108

TEXT (voucher details)

Description:	Description of the voucher.
Format:	String
Version:	CCC 12.0.1
Notes:	You can use a maximum of 50 characters.
Example:	TEXT=Added

TGEO_ID (terminating geo node id)

Description:	The voice call terminating geographic node ID.
Format:	Integer
Version:	CCC 6.0.0
Notes:	
Example:	TGEO_ID=23

TIMED_OUT (reservation confirmation)

Description:	Added when a timed-out reservation confirmation event occurs.
Format:	String
Version:	CCC 6.0.0
Notes:	A RNCf tag will also be present in the EDR.
Example:	TIMED_OUT=TRUE

TN (called number)

Description:	The terminating number (called number) being called.
Format:	String
Version:	CCC 6.0.0
Notes:	
Example:	TN=01473

TN (roaming called number)

Description:	The terminating number (called number) being called.
Format:	String
Version:	CCC 6.0.0
Notes:	<ul style="list-style-type: none"> The roaming software provides a ccsCDRLoaderPlugin on the SMP. This plugin will determine the type of roaming call. If a mobile termination call is determined, then the roaming prefix will be stripped from the TN field.
Example:	TN=016505550100

TYPE_DESCRIPTION (voucher type)

Description:	A textual description for the voucher type.
Format:	String
Version:	CCC 6.0.0
Notes:	
Example:	TYPE_DESCRIPTION=STANDARD

USER (operator logon name)

Description:	The name used by the operator who performed the action to log in to the Convergent Charging Controller UI (user interface).
Format:	String
Version:	CCC 6.0.0
Notes:	
Example:	USER=SU

VOUCHER (ID of redeemed voucher)

Description:	The ID of the redeemed voucher.
Format:	Integer
Version:	CCC 6.0.0
Notes:	This is an internal voucher identifier only (ccs_voucher_reference.ID).
Example:	VOUCHER=68

VOUCHER (serial number of redeemed voucher - 3.1.5)

Description:	The serial number of the redeemed voucher.
Format:	Integer
Version:	CCC 6.0.0
Notes:	This is an internal voucher identifier only (ccs_voucher_reference.serial_number).
Example:	VOUCHER=6878367520

VOUCHER_BATCH (for voucher batch)

Description:	The voucher batch ID.
Format:	Integer
Version:	CCC 6.0.0
Notes:	
Example:	VOUCHER_BATCH=35

VOUCHER_NUMBER (redeemed voucher)

Description:	The voucher number of the redeemed voucher.
Format:	String
Version:	CCC 6.0.0
Notes:	
Example:	VOUCHER_NUMBER=000000067

VOUCHER_TYPE (name)

Description:	Voucher type name.
---------------------	--------------------

Format:	String
Version:	CCC 6.0.0
Notes:	Internal reference (ccs_voucher_type.NAME)
Example:	

WALLET_DELETED (always success - Y)

Description:	Indicates that the wallet was deleted successfully.
Format:	String
Version:	CCC 6.0.0
Notes:	This value will always be 'Y' for the EDR record.
Example:	WALLET_DELETED=N

WALLET_TYPE (ID of wallet changed)

Description:	The ID of the wallet type changed for this call.
Format:	Integer
Version:	CCC 6.0.0
Notes:	This is an internal wallet type reference only (ccs_wallet_type.ID).
Example:	WALLET_TYPE=1

WALLET_TYPE (ID of wallet recharged)

Description:	The ID of the wallet that was recharged.
Format:	Integer
Version:	CCC 6.0.0
Notes:	This is an internal wallet type reference only (ccs_wallet_type.ID).
Example:	WALLET_TYPE=1

33

SLC Generated EDRs

Overview

Introduction

This chapter explains the EDRs generated on the SLC.

ACS EDRs

EDR generation

ACS EDRs are generated and processed by the `slee_acs` on each SLC and uploaded at regular intervals to the SMS using the `cmnPushFiles` process.

Diagram

This diagram shows the components of the ACS installation on the SLC and SMS which generate and migrate EDRs.

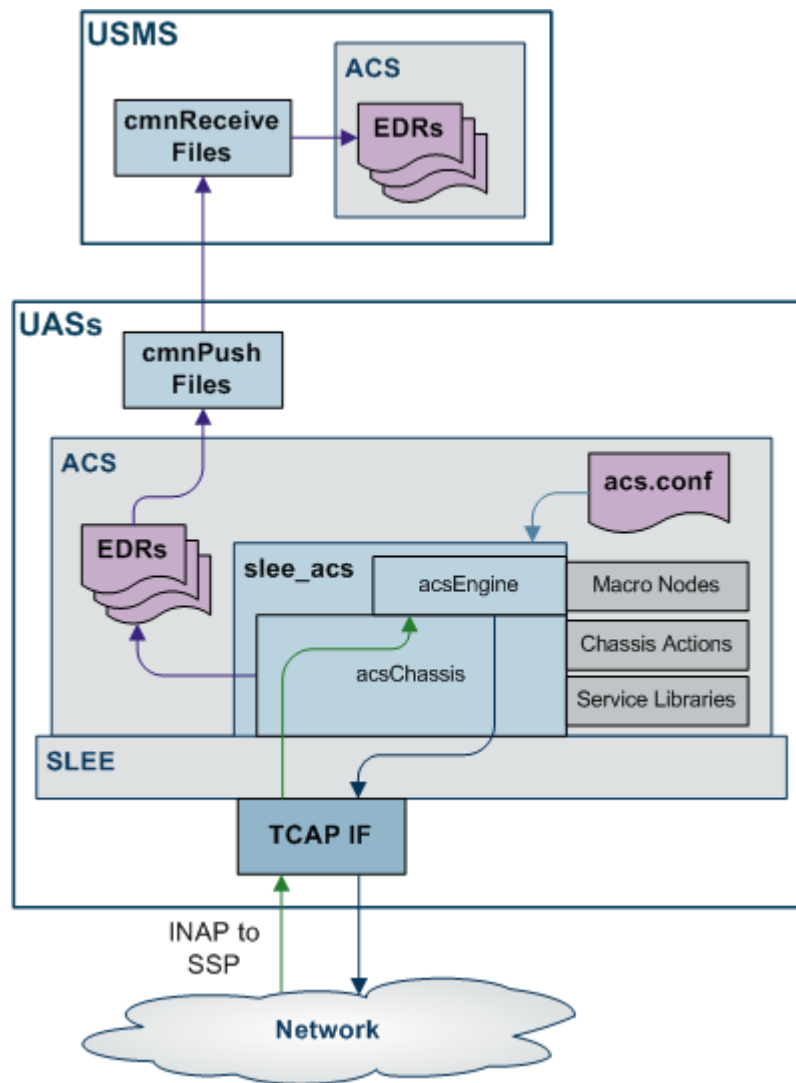

EDR File Names

ACS EDR file names have the following format:

```
machine_app_starttime_closetime_pid.cdr
```

where:

- *machine* is the SLC which generated the EDR.
Note: This is added when the file is moved to the SMS.
- *app* is the application that produced the EDR
- *starttime* is the date and time that the first EDR in the file was created. The format used is: `yyyymmddhh24missff1`, where `ff1` is the decisecond portion of the timestamp.
- *closetime* is the date and time that the last EDR in the file was created and the file closed. The format used is: `yyyymmddhh24missff1`, where `ff1` is the decisecond portion of the timestamp.
Note: This is present if the `CdrFileAppendCloseTime` parameter in `acs.conf` is set.
- *pid* is the Unix Process ID - up to 5 numeric characters.

Note: This is present if the `CdrFileAppendPid` parameter in `acs.conf` is set.

Example file names

File name on SMS, with the default parameter settings (with the PID appended):

```
UAS01_ACS_200805061707_11501.cdr
```

File name on SMS, with the Close Time and PID appended:

```
UAS01_ACS_200805061707_200805061809_11501.cdr
```

EDR collection

The ACS EDRs are saved to file in the following locations on the SMS:

- **IN/service_packages/SMS/cdr/received**
- If customer configured processing is done, they may be moved to:
IN/service_packages/SMS/cdr/processed

File format

The only file format supported by the ACS EDR API is the 'Pipe Tag LineFeed' format. This encodes data using the following format.

```
APP|Tag=Value|Tag=Value[ ,Value...]<LF>
```

The format has the following characteristics:

- `APP` is the name of service which created the EDR.
- The format is entirely formed of printable ASCII characters, plus the LF character (Unix style newline '\n') as a terminator.
- Special characters are:
 - '|' - The pipe character is used to separate fields
 - '=' - The equals character is used to separate Tag and Value
 - ',' - The comma character is used with fields which allow multiple values for a single tag
- Maximum record length is 256 characters (255 + LF)
- The file may contain zero or more records. There is no specified limit to the number of records in any given file, however the maximum file:
 - size is specified in the `CdrFileMaxSize` parameter, and
 - age in the `CdrFileMaxAge` parameter

in `acs.conf`.

- There must be at least one tag in each record.
- The order of tags is not significant and may change, possibly within a single file.
- The presence of any particular tag is not guaranteed.
- There is no dependency of tags (for example: the presence of any specific tag does not guarantee the presence of any related tags).

Example slee_acs EDRs

Example 1

Unsuccessful voice call.

```
ACS|CID=135883|OA=0|OTI=0|CUST=1|SN=81822222|TN=81822222|CGN=81811111|CLI=81811111|
SK=111|TCS=20080506050720|LPN=|LAC=|CS=3|CPC=10|CC=|CPNI=0|PCNA=|TPNI=0|PTNA=|CGNA=|
TGNA=|TFN=ST-1,SDTN-2,UTTP-4,END-3|LGID=0|CPN=81822222|OCPI=|CPNN=3|CGNN=3|CPPI=1|NOAT=0|
CBAT=0|FATS=0|CCTS=20080506050721|HTS=20080506050721|AIDL=
```

Example 2:

Successful national call from CCS on a SLC.

```
CCS|CID=487291|OA=0|OTI=0|CUST=1|SN=123456789|TN=|CGN=7|CLI=123456789|SK=1|
TCS=20060701173254|LPN=|LAC=|CS=1|CPC=10|CC=|CPNI=0|PCNA=|TPNI=0|PTNA=|CGNA=|TGNA=|
TFN=ST-1,uatb-4,DISC-5,END-3|LGID=0|CPN=|OCPI=|CPNN=3|CGNN=3|CPPI=1|NOAT=0|CBAT=0|FATS=0|
CCTS=0|HTS=0|AIDL=|WALR=
```

Example 3:

Voice MO call.

```
VOICE_MO|CID=135883|OA=0|OTI=0|CUST=1|SN=9393009|TN=9393009|CGN=93933301|CLI=6421939340|
SK=2|TCS=20080506050226|TCE=20080506050327|LPN=|LAC=|CS=4|CPC=10|CC=|CPNI=0|PCNA=|TPNI=0|
PTNA=|CGNA=|TGNA=|
TFN=ST-1.0,DDS-68.01,STTP-18.013,CCDR-19.0,CCDR-20.0,uatb-2.01111111,STC-59.01,END-3.0|
LGID=0|CPN=VOICE_MO|CAET=0|CCET=60.0|OCPI=|CPNN=3|CGNN=3|CPPI=1|NOAT=1|CBAT=0|FATS=0|
CCTS=20080506050227|HTS=20080506050227|AIDL=|ANS_TM=20080506050127|BEARER_TYPE=24|
FCA=9393009|LOC_NUM=502180100004465|NT=6|RDPN=21939340|RDPNN=6421939340|RDRES=2|SC=1300|
SST=1|EXT9=12345678
```

ACS EDR tags

The following list details the tag values of EDRs created by the ACS service, the type and length of data required, and a description of the value.

AIDL (played announcement ID list)

Description:	<p>Played Announcement ID List, sequence of ACS_ANNOUNCEMENT_ENTRY.ID</p> <p>This is a comma list of all of the elementary message IDs played during the call in sequence, either as a result of an:</p> <ul style="list-style-type: none"> • INAP PlayAnnouncement, or • INAP PromptAndCollectUserInformation operation.
Format:	comma sequence of unsigned 32-bit integer
Version:	CCC 6.0.0

Notes:	<p>1) Enabled by CdrExtraFields acs.conf flag.</p> <p>2) If the DigitsInAnnouncementList acs.conf flag is set to true, each elementary message ID has the following added immediately after the ID value. If this was:</p> <ul style="list-style-type: none"> • a successful PlayAnnouncement or is not the last elementary message ID in the announcement, then nothing. • PlayAnnouncement, during which the caller abandoned, then "Z" • a successful PromptAndCollectUserInformation, then "<i><digits collected></i>", for example, "^12345678" • PromptAndCollectUserInformation, for which an improper caller response error, or timeout, was received, then "^X" • PromptAndCollectUserInformation, during which the caller abandoned, then "^Z" <p>3) The announcements that match the ids can be seen via the ACS > Configuration > Announcements Tab > Edit screens, the column heading ResourceID are the numbers referred to in the AIDL list.</p>
Examples:	<p>off - AIDL=10, 20, 30, 40</p> <p>on - AIDL=10, 20^X, 20^12345678, 30Z</p>

BCOR (balance cascade override)

Description:	Indicates a balance cascade override was used instead of the original balance cascade.
Format:	Integer
Version:	CCC 6.0.0
Notes:	Used by FOX and DCD InitialTimeReservation and DirectTimeCharge.
Example:	BCOR=257

BFT (billing failure treatment)

Description:	Indicates that Billing Failure Treatment has been used for the call. The value is the total amount of time reserved (including that withheld), before BFT occurred.
Format:	Integer
Version:	CCC 6.0.0
Notes:	<ul style="list-style-type: none"> • This is set by the UATB node. • For a system failure on initial reservation this will be 0.
Example:	BFT=3000

CA (called address)

Description:	Called Address Called address from the CallInformationReport INAP operation.
Format:	This is a string of digits, 0-32 chars. Valid value are: 0-9A-F*#
Version:	CCC 6.0.0
Notes:	Enabled by SendCIR acs.conf flag.
Example:	CA=9393009

CAET (call attempt elapsed time)

Description:	Call Attempt Elapsed Time
Format:	Integer
Version:	CCC 6.0.0
Notes:	Seconds to the nearest second. If elapsedTimesFromApplyChargingReport flag is set to '1' then it is from the Apply Charging Report.
Example:	CAET=20

CBAT (connected by attempt termination)

Description:	Call was connected by attempt termination, was the Connect operation sent along with a RequestReportBCSM to arm for busy, etc.
Format:	Integer
Version:	CCC 6.0.0
Notes:	1 for true, 0 for false.
Example:	CBAT=0

CC (carrier code)

Description:	Carrier Code
Format:	0-9A-F*# (0-32 chars)
Version:	CCC 6.0.0
Notes:	The digits of the carrier code as given in the Set Carrier Code feature node.
Example:	CC=

CCET (call connect elapsed time)

Description:	Call Connect Elapsed Time.
Format:	Seconds to the nearest tenth of a second as a decimal number with one decimal place.
Version:	CCC 6.0.0
Notes:	If elapsedTimesFromApplyChargingReport flag is set to '1' then it is from the Apply Charging Report.
Example:	CCET=121.3 for 121.3 seconds.

CCTS (call connect timestamp)

Description:	Call Connect Timestamp The time the Connect operation was sent to the SSP.
Format:	Date - YYYYMMDDHHMMSSS
Version:	CCC 6.0.0
Notes:	

Example:	CCTS=20080413221947
-----------------	---------------------

CGN (calling network number)

Description:	The normalised digits of the Calling Network Number. The caller's network address as determined by the Chassis. This is derived from one of the parameters of the Initial DP according to the config options on the service line of the acs.conf file.
Format:	0-9A-F*# (0-32 chars)
Version:	CCC 6.0.0
Notes:	From IDP
Example:	CGN=93933301

CGNA (global calling network address)

Description:	Global Calling Network Address, as stored in VPN_STATION.GVNS_ADDRESS
Format:	0-9A-F*# (0-32 chars)
Version:	CCC 6.0.0
Notes:	VPN only. If VPN is not installed, value is blank.
Example:	CGNA=

CGNN (calling party nature of number)

Description:	Calling Party ID Nature of Number
Format:	Integer - 0..255
Version:	CCC 6.0.0
Notes:	The nature of address of the number using the standard ITU-T notation i.e. 1 = subscriber 2 = unknown 3 = national 4 = international
Example:	CGNN=3

CID (slee call ID)

Description:	The slee call ID Unique SLEE identifier assigned to the current call.
Format:	Unsigned 32 bit integer
Version:	CCC 6.0.0
Notes:	
Example:	CID=135883

CLI (calling logical number)

Description:	Calling Line Identifier. The caller's network address as determined by the Chassis. More accurately, the calling logical number. This is derived from one of the parameters of the Initial DP according to the config options on the service line of the acs.conf file.
Format:	0-9A-F*# (0-32 chars)
Version:	CCC 6.0.0
Notes:	From IDP. May match CGN
Example:	CLI=6421939340

CPC (calling party category)

Description:	Incoming Calling Party Category.
Format:	Integer 0..255
Version:	CCC 6.0.0
Notes:	From IDP
Example:	CPC=10

CPN (control plan name)

Description:	Control Plan Name The name of the last ACS Control Plan to be executed for this call.
Format:	String, 0-50 chars
Version:	CCC 6.0.0
Notes:	
Example:	CPN=VOICE_MO

CPNI (calling private network ID)

Description:	Calling Private Network ID This is the database ID of the VPN network from which the call originated.
Format:	Unsigned 32-bit integer
Version:	CCC 6.0.0
Notes:	This is only relevant when using the Convergent Charging Controller VPN product. Otherwise, it is set to 0.
Example:	CPNI=0

CPNN (called party nature of number)

Description:	Called Party Nature of Number. This is the nature of address of the called party number, which is derived from one of the parameters of the Initial DP in the same way as calling logical number and calling network number. In practice, it will be derived from the called party number field of the Initial DP as there are no suitable alternative fields.
Format:	Integer 0..255
Version:	CCC 6.0.0
Notes:	The number itself is held in the EDR as "SN".
Example:	CPNN=3

CPPI (calling party presentation restricted indicator)

Description:	Calling Party Presentation restricted Indicator ("CPPI=0" appears in the EDR.) When it is, it will indicate whether the calling logical number may be presented to subscribers. <ul style="list-style-type: none"> • 1 means no (restricted) • 0 means yes (not restricted).
Format:	Integer 0..255
Version:	CCC 6.0.0
Notes:	Future Field
Example:	CPPI=1

CS (acs connect status)

Description:	Connect Status. Whether ACS tried to connect the call and if so, what happened to it.
Format:	Integer 0 to 12
Version:	CCC 6.0.0

Notes:	<p>Statuses include:</p> <ul style="list-style-type: none"> • 0 Connect status not recorded. • 1 ACS sent a ReleaseCall operation. • 2 ACS sent a Continue operation (or a Connect operation with destination routing address (DRA) set to the called party number in the IDP in certain circumstances. See the ACS Technical guide.) What happened to the call after the operation was sent is not recorded. • 3 ACS attempted to connect the call. What happened to the call after the operation was sent is not recorded. • 4 ACS attempted to connect the call and the call was answered. • 5 ACS attempted to connect the call but the called party was busy. • 6 ACS attempted to connect the call but hit route select failure. • 7 ACS attempted to connect the call but the no answer timeout expired. • 8 ACS attempted to connect the call but either the caller abandoned before answer or a TC abort was received. (TC abort is unlikely.) • 9 ACS got to an END node but there had been a service handover and so, rather than disconnecting the call. It is awaiting an event report for mid call. Only relevant with the VPN product. • 10 ACS sent a Continue operation. What happened to the call after the operation was sent is not recorded. • 11 ACS received a TCAP Abort, unknown status. • 12 ACS received a release by SSP on credit expiry.
Example:	CS=4

CUST (customer database ID)

Description:	ACS Customer Database ID (From the ACS_CUSTOMER table).
Format:	Unsigned 32-bit integer.
Version:	CCC 6.0.0
Notes:	The customer is the one who "owns" the call. The meaning of "own" is service specific. For example, with the ACS service it is the customer who owns the called number or the calling number record that triggered the Control Plan.
Example:	CUST=1

DISC (discount override)

Description:	Identifies the discount percentage override used instead of the original (if any) discount that was to be applied.
Format:	Integer
Version:	CCC 6.0.0
Notes:	<ul style="list-style-type: none"> • May be a comma separated list of discount values. • Used by FOX and DCD InitialTimeReservation and DirectTimeCharge.
Example:	DISC=15

EXT(0-9) (extension buffer contents)

Description:	<p>There are 10 extension digits buffers in ACS numbered 0 to 9. These can be populated via, for example, decoding extensions from the Initial DP.</p> <p>Whenever a EDR is logged, the values of all the non-empty extension digits buffers will be put in the EDR.</p>
---------------------	--

Format:	Integer
Version:	CCC 6.0.0
Notes:	
Example:	If extension buffer 0 contains 12345678 and extension buffer 5 contains 222 you will get: EXT0=12345678 EXT1=222

FATS (first announcement timestamp)

Description:	First Announcement Timestamp The time the first PlayAnnouncement or PromptAndCollectUserInformation operation was sent to the SSP for this call.
Format:	Date (yyyymmddhhmmss format)
Version:	CCC 6.0.0
Notes:	
Example:	FATS=0

HTS (hunting timestamp)

Description:	Hunting time stamp. The time the first Connect operation was sent for this call. N.B. Not necessarily the 1st Connect for this hunt group.
Format:	Date (yyyymmddhhmmss format)
Version:	CCC 6.0.0
Notes:	
Example:	HTS=20080413221947

LAC (last account code used)

Description:	Last Account Code Digits of the last account code used in this call. Most recent Account Code entered during the service logic.
Format:	0-9A-F*# (0-32 chars)
Version:	CCC 6.0.0
Notes:	See AC node
Example:	LAC=

LGID (language ID)

Description:	Language ID From first match in loaded profile The ACS database ID of the language used for announcements etc. From the ACS_LANGUAGE table.
---------------------	---

Format:	Unsigned 32-bit integer.
Version:	CCC 6.0.0
Notes:	
Example:	LGID=0

LPN (most recent pin entered)

Description:	Last PIN Number. Most recent PIN entered during the service logic. The digits of the last PIN collected by a PIN authorisation node for this call.
Format:	0-9A-F*# (0-32 chars)
Version:	CCC 6.0.0
Notes:	See PIN authorisation node.
Example:	LPN=

MCOR (maximum charge override)

Description:	Indicates a maximum charge override was used instead of the original (if any) maximum charge that was to be applied.
Format:	Integer
Version:	CCC 6.0.0
Notes:	<ul style="list-style-type: none"> If no maximum charge override has been used, the value is -1. Used by FOX and DCD InitialTimeReservation and DirectTimeCharge.
Example:	MCOR=-1

NOAT (number of attempt terminations)

Description:	Number of Attempt Terminations The number of times an attempt termination type node has been encountered for this call, that is, the number of times a Connect operation has been sent with busy, RSF and similar, EDPs armed.
Format:	Integer 0..255
Version:	CCC 6.0.0
Notes:	
Example:	NOAT=1

NT (network type)

Description:	Network type (determined from Service Key).
Format:	Integer
Version:	CCC 6.0.0
Notes:	<ul style="list-style-type: none"> 0 = Unspecified 1 = CDMA 2 = TDMA

Example:	NT=0
-----------------	------

OA (sccp originating address)

Description:	The SCCP Originating Address where the TCAP messages are coming from.
Format:	Integer
Version:	CCC 6.0.0
Notes:	This would be 0 if you haven't included it in your test tool (slpit) script.
Example:	OA=0

OCPI (original called party)

Description:	Original Called Party The digits of the original called party ID form the Initial DP.
Format:	0-9A-F*# (0-32 chars)
Version:	CCC 6.0.0
Notes:	From IDP
Example:	OCPI=

OTI (originating transaction ID)

Description:	Originating Transaction ID TCAP transaction ID for invoking Internal DP.
Format:	Integer
Version:	CCC 6.0.0
Notes:	
Example:	OTI=0

PCNA (calling private network address)

Description:	Calling Private Network Address. The VPN address of the calling station.
Format:	0-9A-F*# (0-32 chars)
Version:	CCC 6.0.0
Notes:	VPN only. If VPN is not installed, value is blank.
Example:	PCNA=

PTNA (private terminating network address)

Description:	Private Terminating Network Address. The VPN address of the terminating station.
---------------------	---

Format:	0-9A-F*# (0-32 chars)
Version:	CCC 6.0.0
Notes:	VPN only. If VPN is not installed, value is blank.
Example:	PTNA=

RELC (acs release cause)

Description:	Release Cause. The decimal value of the release cause, either from the CallInformationReport or from the ReleaseCall operation sent by ACS (as appropriate). For the coding of release causes, see ITU_T recommendation Q.850.
Format:	Integer 0..255
Version:	CCC 6.0.0
Notes:	Enabled by SendCIR acs.conf flag.
Example:	RELC=31

SK (service key)

Description:	Service Key Numeric service key invoking service. The decimal value of the INAP service key from the Initial DP operation.
Format:	Unsigned 32-bit integer.
Version:	CCC 6.0.0
Notes:	From IDP
Example:	SK=1000

SN (service number)

Description:	Service (original called) Number The called party number. Called number which invoked the service (for example, 1-800...). See notes for <i>CPNN</i> .
Format:	0-9A-F*# (0-32 chars)
Version:	CCC 6.0.0
Notes:	
Example:	SN=9393009

TCE (acs time call ended)

Description:	Time Call End
Format:	Date
Version:	CCC 6.0.0
Notes:	If elapsedTimesFromApplyChargingReport flag is set to '1' then it is from the Apply Charging Report.

Example:	TCE=20080413222047
-----------------	--------------------

TCS (acs time call started)

Description:	Time Call Start The start time of the call.
Format:	Date
Version:	CCC 6.0.0
Notes:	
Example:	TCS=20080413221947

TFN (tracked feature node list)

Description:	Tracked feature node list. A Comma separated list of feature nodes traversed in the Control Plan. The complete set of mnemonics is: <ul style="list-style-type: none"> • {"ST", "Start"}, • {"END", "End"}, • {"UT", "Unconditional Termination"}, • {"AT", "Attempt Termination"}, • {"PLAY", "Play Announcement"}, • {"DOY", "Day of year"}, • {"DOW", "Day of week"}, • {"TOD", "Time of day"}, • {"DN", "Dialled Number"},
	<ul style="list-style-type: none"> • {"CP", "Calling Party"}, • {"GR", "Geographic Region"}, • {"PD", "Proportional Distribution"}, • {"EV_C", "Event counting"}, • {"EV_S", "Event setting"}, • {"EV_B", "Event branching"}, • {"DISC", "Disconnect Call"}, • {"SD", "Selection dependent routing"}, • {"SHO", "Service Handover"}, • {"PINA", "PIN Authorisation"},
	<ul style="list-style-type: none"> • {"ACE", "Account Code Entry"}, • {"CDPT", "Collect Digits to pending TN"}, • {"CDST", "Collect digits to sub tag"}, • {"CF", "Call filtering"}, • {"TPTT", "Test Pending TN Type"}, • {"SEPP", "Set Pending TN from Profile"}, • {"TOWP", "Time of week profile"}, • {"ATTP", "Attempt terminate to pending"}, • {"UTTP", "Unconditional terminate to pending"}, • {"PB", "Profile branching"},

	<ul style="list-style-type: none"> • {"MCM", "Mid call mark"}, • {"STTP", "Store pending TN to profile"}, • {"DDS", "Dynamically driven switch"}, • {"NLT", "Number lookup and translate"}, • {"ACP", "Activate Control Plan"}, • {"ALP", "ACS Load Profile"}, • {"CPC", "Calling Party Category"}, • {"SCC", "Set carrier code"}, • {"MCJ", "Mid Call Jump"}, • {"STC", "Set Tariff code"},
	<ul style="list-style-type: none"> • {"CPNT", "Control Plan Notes"}, • {"CONT", "Terminate Unchanged"}, • {"PAPV", "Play Variable Part Announcement"}, • {"MTCH", "Number Matching"}, • {"SSMF", "Send Short Message F"}, • {"CNPA", "Set Cut and Paste"}, • {"CUTC", "Cut Calling Number"}, • {"SDTN", "Store Digits to Pending TN"}, • {"TPTT", "Test Pending TN Type"}, • {"STPF", "Store Profile"}
Format:	String. Comma sequence of type-#,type-#...
Version:	CCC 6.0.0
Notes:	Enabled by CdrExtraFields acs.conf parameter.
Example:	<p>If CdrExtraFields is set to 1 (track traversed feature nodes and played announcements - the default):</p> <p>"TFN=ST-1 , SDTN-2 , UTTP-4 , END-3" for a:</p> <ul style="list-style-type: none"> • Start node (node number 1), • Store Digits to Pending TN node (node number 2), • Unconditional terminate to pending (node number 4) and • End (node number 3). <p>If CdrExtraFields is set to 2 (include node substates):</p> <p>"TFN=ST-1.0 , SDTN-2.012 , UTTP-4.01 , END-3.0"</p>

TGNA (global terminating network address)

Description:	Global Terminating Network Address VPN_STATION.GVNS_ADDRESS
Format:	String, zero, up to 32 characters.
Version:	CCC 6.0.0
Notes:	<ul style="list-style-type: none"> • VPN only • Characters 0-9A-F*# • If VPN is not installed, value is blank.
Example:	TGNA=

TN (acs termination number)

Description:	<p>Termination number.</p> <p>The number we returned to the SSP in Connect, or empty for Disconnect/Continue. The digits of the destination routing address (DRA) in the Connect operation.</p>
---------------------	---

Format:	String, zero, up to 32 characters.
Version:	CCC 6.0.0
Notes:	<ul style="list-style-type: none"> From Control Plan. Characters 0-9A-F*#
Example:	TN=9393009

TPNI (terminating private network ID)

Description:	Terminating Private Network ID This is the database ID of the VPN network to which the call is made.
Format:	unsigned 32-bit integer.
Version:	CCC 6.0.0
Notes:	VPN only. If VPN is not installed, value is blank.
Example:	TPNI=0

TPO (tariff plan override)

Description:	Identifies the tariff plan used to override the original tariff plan that was to be applied.
Format:	Integer
Version:	CCC 6.0.0
Notes:	Used by FOX and DCD InitialTimeReservation and DirectTimeCharge.
Example:	TPO=667

WALR (wallet reference)

Description:	Identifies the affected wallet if the ID is available.
Format:	Integer
Version:	CCC 6.0.0
Notes:	Used by FOX and DCD InitialTimeReservation and DirectTimeCharge.
Example:	WALR=

DCD EDRs

EDR Generation

EDRs are generated and processed by the `slee_acs` on the SLC and uploaded at regular intervals to the SMS using the `cmnPushFiles` process.

Diameter Charging Driver (DCD) tags are appended to the EDRs generated by the Advanced Control Services application. See *Event Detail Record Reference Guide* for the full list and descriptions.

DCD EDR Tags

Here are the EDR tags produced by DCD.

DIA_RC (result code)

Description:	Number indicating diameter result-code received in CCA message.
Format:	Integer
Concept:	Result-Code
Notes:	
Example:	DIA_RC=2001

DIA_REQ (current session message number)

Description:	Sequential number, indicating message within the current session.
Format:	Integer
Concept:	CC-Request-Number
Notes:	For Diameter event based messages, this will always be 0, and hence not recorded.
Example:	DIA_REQ=1

DIA_SID (session id)

Description:	This is a unique value identifying the Diameter session.
Format:	Of the form: <i>DiameterIdentity;time;SLEE_CallID</i> Where: <ul style="list-style-type: none"> <i>DiameterIdentity</i> is that of the SLC (that is, the Origin-Host used in the CCR message) <i>time</i> is the time of the first request (expressed as the number of seconds since the Unix epoch time) <i>SLEE_CallID</i> is a unique call identifier used by the SLEE processes to track each active session
Concept:	Session-ID
Notes:	The values for <i>time</i> and <i>SLEE_CallID</i> are in decimal format, but they are actually sent out in hexadecimal format.
Example:	DIA_SID=scp1.oracle.com;47A228C3;15459A

DIA_TIME (time ccr sent)

Description:	The time the CCR was sent, in hundredths of second
Format:	Date - "YYYY-MM-DD-HH-MM-SSSS"
Concept:	Session-ID
Notes:	
Example:	DIA_TIME=2008-03-27-20-41-3831

Custom Tag Names

The `cdrTag` configuration parameter allows for an EDR to have tag names that are customer defined.

Example EDRs

Here are some example EDRs generated by DCD.

Refer to *ACS EDR Tags* for the non-DCD tags.

Example 1

Whole EDR for an InitialTimeReservation and ConfirmTimeReservation:

```
EDR: 'VOICE_MO|CID=285222|OA=0|OTI=0|CUST=1|SN=0777666444|TN=0777666444|CGN=8888887|
CLI=8888887|SK=1|TCS=20080327204138|TCE=20080327204241|LPN=|LAC=|CS=4|CPC=10|CC=|CPNI=0|
PCNA=|TPNI=0|PTNA=|CGNA=|TGNA=|TFN=ST-2,SDTN-21,uatb-3,PB-22,END-14|LGID=0|
CPN=uatbWcseBrch|CAET=3|CCET=60.0|CA=60777666555|RELC=17|OCPI=|CPNN=3|CGNN=3|CPPI=1|
NOAT=1|CBAT=0|FATS=0|CCTS=20080327204138|HTS=20080327204138|AIDL=|DIA_SID=nzwn-test03-
z2;47ec0682;45a26|DIA_REQ=0|DIA_RC=2001|DIA_TIME=2008-03-27-20-41-3831|DIA_SID=nzwn-
test03-z2;47ec0682;45a26|DIA_REQ=1|DIA_RC=2001|DIA_TIME=2008-03-27-20-41-3847|
FCA=60777666555|WALR=86'
```

Note the DCD part of the EDR. All four tags are present twice:

- The Initial Time Reservation

```
DIA_SID=nzwn-test03-z2;47ec0682;45a26|DIA_REQ=0|DIA_RC=2001|
DIA_TIME=2008-03-27-20-41-3831|
```

- The Termination Time Reservation

```
DIA_SID=nzwn-test03-z2;47ec0682;45a26|DIA_REQ=1|DIA_RC=2001|
DIA_TIME=2008-03-27-20-41-3847|
```

Example 2

Whole EDR for DirectNamedEvent:

```
EDR: 'VOICE_MO|CID=287224|OA=0|OTI=0|CUST=1|SN=0777666444|TN=|CGN=8888887|CLI=8888887|
SK=1|TCS=20080327231115|TCE=0|LPN=|LAC=|CS=1|CPC=10|CC=|CPNI=0|PCNA=|TPNI=0|PTNA=|CGNA=|
TGNA=|TFN=ST-1,bevt-2,END-3|LGID=0|CPN=DirectDebit|CAET=0|CCET=0.0|CA=|RELC=31|OCPI=|
CPNN=3|CGNN=3|CPPI=1|NOAT=0|CBAT=0|FATS=0|CCTS=0|HTS=0|AIDL=|DIA_SID=nzwn-test03-
z2;47ec2993;461f8|DIA_RC=2001|DIA_TIME=2008-03-27-23-11-1577'
```

Note in the DCD part of the EDR that event based EDRs only need to receive DIA_SID, DIA_RC and DIA_TIME, that is, no DIA_REQ:

```
DIA_SID=nzwn-test03-z2;47ec2993;461f8|DIA_RC=2001|DIA_TIME=2008-03-27-23-11-1577'
```

Example 3

For cdrTag for MMM_TAG and ZZZ_TAG, the following would be an example of what the resulting EDR would look like.

```
CSS_BE|CID=205383|OA=0|OTI=0|CUST=1|SN=1130|TN=|CGN=0212994768|CLI=0212994768|SK=3|
TCS=20091117192600|LPN=|LAC=|CS=1|CPC=10|CC=|CPNI=0|PCNA=|TPNI=0|PTNA=|CGNA=|TGNA=|
TFN=ST-1,CCDR-8,CCDR-12,CCDR-14,bevt-2,DISC-3,END-7|LGID=0|CPN=ST-BE-END|OCPI=|CPNN=3|
CGNN=3|CPPI=1|NOAT=0|CBAT=0|FATS=0|CCTS=0|HTS=0|AIDL=|AAA_TAG=11111|CMX_EC=CR96791|
CMX_EN=BasicTest|DIA_SID=eng-host06-z6.usp.co.nz;4b02f8c8;32247|DIA_RC=2001|
DIA_TIME=2009-11-17-19-26-0062|MMM_TAG=55555|ZZZ_TAG=777
```

SCA EDRs

EDR collection

The SCA can be configured to produce EDRs for use in post processing as required. The EDRs are saved to file in a location specified in the **sca.config**.

EDRs are saved to file in tag/value pairs, separated by "|", in the following form:

```
tag1=value1|tag2=value2
```

Field formats

Each field in an EDR is in a particular format, summarized in this table.

Format	Description
Date / Time	<p>A time to the nearest second, in format <i>YYYYMMDDHHmmSS</i> where:</p> <ul style="list-style-type: none"> • <i>YYYY</i> = year (for example, 2005) • <i>MM</i> = month (for example, 03 for March) • <i>DD</i> = day of the month (for example, 09) • <i>HH</i> = hours (for example, 13 for 1pm) • <i>mm</i> = minutes (for example, 32) • <i>SS</i> = seconds (for example, 00) <p>Example: A request submitted on 16th November 2007 1 minute and 14 seconds after midnight <code>TIMESTAMP=20071116000114</code></p>
Integer	<p>A decimal number. Will never exceed a 32 bit number (11 digits), but is often shorter. Leading zeros will not normally be present.</p> <p>Example: <code>DURATION=30</code></p>
String	<p>String of characters. Can be any length. Should not contain the characters = or . May include spaces. When the parameter is a string, the string consists of all the characters after the = sign up to the separator between this parameter and the next.</p> <p>Example: <code>REQUEST_URI=aname@oracle.com;SLEESK=1</code></p>

Notes: Tags may not necessarily be in a fixed order, as the order of processing may vary from one call type to another.

EDR fields

Here are the SCA tags within an EDR.

CDR_TYPE (sca reason for record generation)

Description:	Type of EDR (that is, where and why it was generated).
Format:	Integer
Version:	CCC 6.0.0

Notes:	1 - Call attempt 2 - Success 3 - Error
Example:	CDR_TYPE=2

DURATION (session duration)

Description:	The session duration (in seconds).
Format:	Integer
Version:	CCC 6.0.0
Notes:	This tag value is only present where the CDR_TYPE is 2.
Example:	DURATION=30

FROM (sip message from header)

Description:	Contains the contents of the From header in the SIP message.
Format:	String
Version:	CCC 6.0.0
Notes:	
Example:	FROM=

METHOD (sip method of request)

Description:	The SIP method for the request that caused the EDR to be generated.
Format:	String
Version:	CCC 6.0.0
Notes:	
Example:	METHOD=

REQUEST_URI (uri request content)

Description:	Contains the contents of the URI request.
Format:	String
Version:	CCC 6.0.0
Notes:	
Example:	REQUEST_URI=aname@oracle.com;SLEESK=1

TIMESTAMP (creation timestamp of sca edr)

Description:	The date and time when the EDR was generated.
Format:	Date
Version:	CCC 6.0.0
Notes:	
Example:	TIMESTAMP=20071116000114

TO (sip to header content)

Description:	Contains the contents of the To header in the SIP message.
Format:	String
Version:	CCC 6.0.0
Notes:	
Example:	TO=

NP EDRs

Introduction

The NP Service Pack produces ACS and LCR EDRs, on the SLC, for use in post processing as required.

EDR collection

Each call processed can produce a single EDR, or multiple EDRs, depending on the type and outcome of the call. As a minimum, each call invokes either an ACS or a CCS service, producing one ACS/CCS EDR for every termination attempt.

Where Least Cost Routing (LCR) is invoked, an LCR EDR is produced for every carrier selected for termination as part of the LCR service logic, in addition to the ACS/CCS EDR produced for every termination attempt. This means that the number of LCR EDRs and the number of ACS/CCS EDRs produced for the call is the same.

NP EDR files

The EDRs are saved to file in a location specified in the **cdrIF.cfg** configuration file. For details, see Configuring EDR Collection.

EDR files have the following names, depending on the EDR type.

EDR Type	File Name
ACS	ACS_ <i>yyyymmddhhss</i> _ <i>PID</i> .cdr
LCR	LCR_ <i>yyyymmddhhss</i> _ .cdr

Where:

- *yyyymmddhhss* = the date and time when the file was opened
- *PID* = the Unix process ID of the service instance that created the EDR file

Note: For the LCR EDRs, the file name is configured in the **cdrIF.cfg** and may be different to the format described in this topic.

Later the files are moved by the **cmnPushFiles** process from each SLC to a configurable location on the SMS. This location is specified in the **cmnPushFilesStartup.sh** script located in the **NP_SERVICE_PACK/bin** directory of each SLC.

The cdr files moved from the SLCs are prefixed with the name of their corresponding SLC, that is, **LCR_YYYYMMDDHHMMSS.cdr** from 'SLC1' will be renamed to **SLC1_LCR_YYYYMMDDHHMMSS.cdr** in the SMS.

Note: If the location directories for the EDR files are changed manually to something different from the package defaults, the new location directories will have to be manually created in the system and the process that create and move the EDR files (cmnPushFiles and cdrIF) will have to be manually restarted.

EDR fields

EDRs are saved to file in tag/value pairs, separated by "|", each record separated by a Unix newline character, in the following form:

```
APP|tag1=value1|tag2=value2|...
```

Note: The first field in the EDR is not a tag/value pair. It contains the name of the service (either ACS or CCS) that created the EDR. For more information about the format of SLC generated EDRs, see *SLC Generated EDRs*.

For LDR EDRs, the row trailer (newline) and column separator can be configured in the **cdriF.cfg** and may be different to the default described in this topic.

NP ACS tags

The following ACS tags are generated in the EDR.

- *AIDL (played announcement ID list)*
- *CA*
- *CAET*
- *CBAT*
- *CCET*
- *CCTS*
- *CGNA*
- *CGNN*
- *CID*
- *CLI*
- *CPC*
- *CPN*
- *CPNI*
- *CPNN*
- *CPPI*
- *CS*
- *CUST*
- *FATS*
- *HTS*

- LAC
- LGID
- LPN (not applicable for NP)
- NOAT
- OA
- OCPI
- OTI
- PCNA (not applicable for NP)
- PTNA (not applicable for NP)
- RELC
- SK
- SN
- TCE
- TCS
- TFN
- TGNA (not applicable for NP)
- TN
- TPNI (not applicable for NP)

Note: These are standard tags, as described in *ACS EDR tags* .

Example ACS EDRs

Example 1

This example shows the output produced for a successful termination attempt EDR.

```
ACS|CID=61080|OA=0|OTI=0|CUST=1|SN=2125551212|TN=2125551212|
CGN=93933301|CLI=3135551212|SK=111|TCS=20051026133312|
TCE=20051026133317|LPN=|LAC=|CS=4|CPC=10|CC=|CPNI=0|PCNA=|TPNI=0|
PTNA=|CGNA=|TGNA=|TFN=ST-1,DDS-5,ATTP-6,ATTP-8,END-3|LGID=0|
CPN=atp|CAET=5|CCE=0.1|CA=2125551212|RELC=16|OCPI=|CPNN=1|
CGNN=4|CPPI=1|NOAT=2|CBAT=1|FATS=0|CCTS=20051026133312|
HTS=20051026133312|AIDL=
```

Example 2

This example shows the output produced for a failed termination attempt EDR.

```
ACS|CID=61080|OA=0|OTI=0|CUST=1|SN=2125551212|TN=2125551212|
CGN=93933301|CLI=3135551212|SK=111|TCS=20051026133312|
TCE=20051026133312|LPN=|LAC=|CS=0|CPC=10|CC=|CPNI=0|PCNA=|
TPNI=0|PTNA=|CGNA=|TGNA=|TFN=ST-1,DDS-5,ATTP-6|LGID=0|CPN=atp|
CAET=0|CCE=0.0|CA=2125551212|RELC=25|OCPI=|CPNN=1|CGNN=4|
CPPI=1|NOAT=1|CBAT=0|FATS=0|CCTS=20051026133312|
HTS=20051026133312|AIDL=
```

LCR EDR tags

The following standard ACS tags are generated in the LCR EDR.

- *CID*
- *CLI*
- *CPN*
- *CUST*
- *SK*
- *SN*

Note: These are standard tags, as described in *ACS EDR tags* .

LCR EDRs do not contain any information on whether the termination attempt was successful or not – this data is stored in the ACS/CCS EDRs.

The LCR EDRs also contain the same CID field that can be used for correlation purposes with ACS/CCS EDRs and with other LCR EDRs.

The following LCR tags are unique to NP.

CALLINGNOA (noa of callingnum)

Description:	The nature of address of the CALLINGNUM.
Format:	A single digit
Version:	CCC 6.0.0
Notes:	
Example:	CALLINGNOA=4

CALLINGNUM (lcr set calling number)

Description:	The calling number set by the LCR service. This is the number that the service uses as the calling number when an attempt is made to connect the call.
Format:	Integer. May be up to 32 digits long.
Version:	CCC 6.0.0
Notes:	
Example:	CALLINGNUM=33111111111111

CARRIERNAME (carrier name)

Description:	The name of the selected carrier.
Format:	String. May be up to 30 characters long.
Version:	CCC 6.0.0
Notes:	
Example:	CARRIERNAME=Test

CARRIERPOS (position of carrier name in hunt list)

Description:	The position of the selected carrier in the hunt list.
Format:	Integer from 1 to 8.

Version:	CCC 6.0.0
Notes:	
Example:	CARRIERPOS=2

ORIGTRUNK (idp location number content)

Description:	Contains contents of location number field from the IDP.
Format:	integer
Version:	CCC 6.0.0
Notes:	
Example:	ORIGTRUNK=441473

PID (unix process ID)

Description:	The Unix process ID of the service instance.
Format:	Integer
Version:	CCC 6.0.0
Notes:	
Example:	PID=4355

PTI (product type ID)

Description:	The product type ID for the CCS account type of the calling subscriber.
Format:	Integer
Version:	CCC 6.0.0
Notes:	
Example:	PTI=2

ROUTEDEST (routing destination for call)

Description:	The routing destination for the call.
Format:	String. May be up to 64 characters long.
Version:	CCC 6.0.0
Notes:	
Example:	ROUTEDEST=Destination_3

TIME (creation timestamp of lcr edr)

Description:	The timestamp for when the LCR EDR was created.
Format:	Date
Version:	CCC 6.0.0
Notes:	
Example:	TIME=20051020154857

TNNOA (noa of terminating number)

Description:	The nature of address of the terminating number.
Format:	Integer. A single digit.
Version:	CCC 6.0.0
Notes:	This should correspond to the first digit of the TNNUM field.
Example:	TNNOA=4

TNNUM (lcr terminating number)

Description:	The terminating number set by the LCR service (the number that the service attempts to connect to).
Format:	Number. May be up to 32 digits long.
Version:	CCC 6.0.0
Notes:	The first digit of the number provides an indication of the NOA.
Example:	TNNUM=4ABCD12AB987654321

Example LCR EDRs

Example 1

This example shows the output produced for a successful termination attempt EDR.

```
PID=4355 | CID=142163 | CUST=1 | SN=987654321 | TNNUM=4ABCD12AB987654321 | TNNOA=4 |
CLI=3311111111111111 | SK=111 | CPN=Rob_HR_LCR_plan | PTI=2 | TIME=20051020154857 |
CALLINGNUM=3311111111111111 | CALLINGNOA=4 | ROUTEDEST=Destination_3 | CARRIERNAME=Test Carrier
2 | CARRIERPOS=2 | ORIGTRUNK=441473
```

Example 2

This example shows the output produced for a failed termination attempt EDR.

```
PID=4355 | CID=142163 | CUST=1 | SN=987654321 | TNNUM=4123412AB987654321 | TNNOA=4 |
CLI=3311111111111111 | SK=111 | CPN=Rob_HR_LCR_plan | PTI=2 | TIME=20051020154857 |
CALLINGNUM=3311111111111111 | CALLINGNOA=4 | ROUTEDEST=Destination_3 | CARRIERNAME=Test Carrier
1 | CARRIERPOS=1 | ORIGTRUNK=441473
```

Messaging Manager EDRs

EDR collection

The xmsTrigger of Messaging Manager produces EDRs to be used in post processing as required.

Diagram

This diagram shows the components on the SLC that generate and migrate Messaging Manager EDRs.

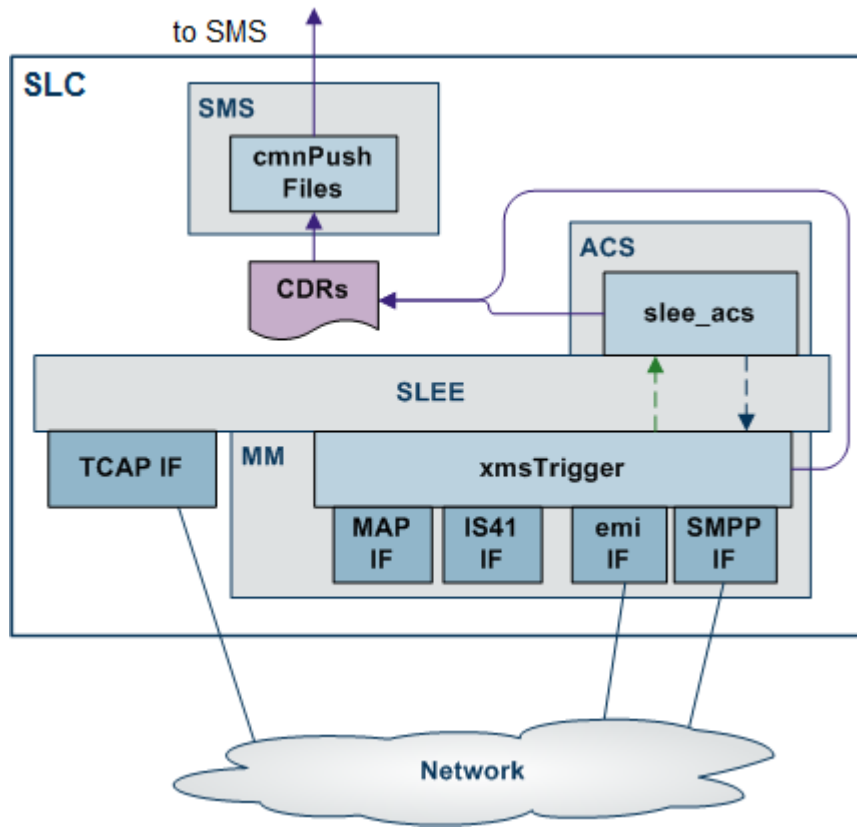

File name and location

Messaging Manager EDRs are saved to file, in the **eserv.config**:

- With the base filename specified by the filename parameter (in the format *Base_file_nameDate_and_time .cdr*)
- In the location specified by the destdir parameter (by default `"/IN/service_packages/XMS/cdr/closed/"`)

File format

EDRs are saved to file in tag/value pairs, separated by "|", in the following form:

tag1=value1|tag2=value2

Field formats

Each field in an EDR is in a particular format, summarised in this table.

Format	Description
Boolean	Value of 0 (untrue) or 1 (true). Example: DLVR=1

Format	Description
Date / Time	<p>A time to the nearest second, in format YYYYMMDDHHMMSS where:</p> <ul style="list-style-type: none"> YYYY = year (for example, 2004) MM = month (for example, 04 for March) DD = day of the month (for example, 09) HH = hours (for example, 13 for 1pm) mm = minutes (for example, 32) SS = seconds (for example, 00) <p>Example: A message submitted on 16th May 2004 1 minute and 14 seconds after midnight DATE=20040516000114</p>
Integer	<p>A decimal number. Will never exceed a 32 bit number (11 digits), but is often shorter. Leading zeros will not normally be present.</p> <p>Example: ULEN=30</p>
Network Number	<p>A sequence of hexadecimal characters representing a phone number. Usually consists of only the characters 0 – 9, but can also contain A – F (representing characters such as # and *). Leading zeros will be present if required.</p> <p>Example: DADR=0020006449393471</p>
String	<p>String of characters. Can be any length. Should not contain the characters = or . May include spaces. When the parameter is a string, the string consists of all the characters after the = sign up to the separator between this parameter and the next.</p> <p>Example: USRD=hello, whats up</p>

Notes:

- Tags may not necessarily be in a fixed order, as the order of processing may vary from one call type to another.
- Some fields will not be present if the call does not reach the call state that produces them – for example, the call duration will not be present for calls which are not answered.

Messaging Manager EDR tags

This topic describes the tags within an EDR. The EDR content can include the user payload (SMS text).

ADAP (adaptations)

Description:	If MMS adaptations are allowed for this message
Format:	Integer
Version:	CCC 6.0.0
Notes:	
Example:	ADAP=1

ALPH (alphabet name)

Description:	The alphabet name
Format:	String
Version:	CCC 6.0.0

Notes:	See a list of character sets specified by the alphabet parameter
Example:	ALPH=GSM7Bit

APPA (auxiliary applications)

Description:	Auxiliary applications for MMS messages
Format:	String
Version:	CCC 6.0.0
Notes:	
Example:	APPA=MAFIA instance #04

APPD (destination application)

Description:	The destination application for MMS messages
Format:	String
Version:	CCC 6.0.0
Notes:	
Example:	APPD=ifx.com.neon.downloadedPackage.MAFIA

APPR (reply application)

Description:	The reply application for MMS messages
Format:	String
Version:	CCC 6.0.0
Notes:	
Example:	APPR=ifx.com.neon.downloadedPackage.MAFI

ASAD (ip of originating asp)

Description:	The IP address of the originating ASP
Format:	String
Version:	CCC 6.0.0
Notes:	
Example:	

ASPDF (asp definition)

Description:	The ASP definition. This can be used to derive the connection path using the config file. The tag will be added to EDRs for messages sent/relayed by MM using EMI or SMPP.
Format:	String
Version:	CCC 6.0.0

Notes:	This tag will be logged in the following format: ASPDF=ASPSname.S.smscLoginId where: <ul style="list-style-type: none"> ASPSname - The value of the ASPS.name entry in the config file. This entry in the config file identifies the ASP from which this messages originated. smscLoginId - The value of the corresponding ASPS.smscLogins.smscConnection.smscLoginId entry. This entry in the config files identifies the SMSC connection where the message was sent.
Example:	

ASPID (inbound and outbound path)

Description:	The inbound path and the outbound path.
Format:	String
Version:	CCC 6.0.0
Notes:	Used twice
Example:	

AXAD (ip connections from asp)

Description:	This is used for IP connections from ASPs.
Format:	String
Version:	CCC 6.0.0
Notes:	It indicates the internet listen address used for the ASP connection.
Example:	

BILLID

Description:	The billing identifier allows the ASP to send some extra billing information to the SMSC.
Format:	String
Version:	CCC 6.0.0
Notes:	BILLID can come from incoming EMI or SMPP messages. In EMI it is the item tagged 12 in the extra services part of the message and is a variable length string. In SMPP it is referred to as "billing identification" and is the TLV tagged 0x060B (1547). See the SMPP version 5 spec for more information.
Example:	

CCLS (mms content class)

Description:	The MMS content class.
Format:	Integer
Version:	CCC 6.0.0

Notes:	0=None 1=Text 2=Basic Image 3=Rich Image 4=Basic Video 5=Rich Video 6=MegaPixel 7=Basic Content 8=Rich Content
Example:	CCLS=1

CHPY (charged party)

Description:	The charged party for the MMS.
Format:	Integer
Version:	CCC 6.0.0
Notes:	0=None 1=Sender 2=Recipient 3=Both 4=Neither 5=Third Party
Example:	CHPY=1

CT (mime type)

Description:	The MIME type as specified in SIP or email messages.
Format:	String
Version:	CCC 6.0.0
Notes:	
Example:	CT=text/plain

DADR (destination address)

Description:	The destination address
Format:	Refer to <i>EDR address format</i> .
Version:	CCC 6.0.0
Notes:	
Example:	DADR=tel:0020006449383471

DATE (timestamp sms sent to mmx)

Description:	The date and time at which the short message was submitted to MM.
Format:	Date
Version:	CCC 6.0.0

Notes:	
Example:	DATE=20080901041701

DELTS (timestamp of delivery attempt)

Description:	The delivery timestamp. The time of delivery attempt.
Format:	Date
Version:	CCC 6.0.0
Notes:	
Example:	DELTS=20041214040046

DIMSI (destination imsi)

Description:	The destination IMSI.
Format:	Integer
Version:	CCC 6.0.0
Notes:	Only included where MM has attempted FDA. B party IMSI of FDA messages.
Example:	

DISTS (timestamp of discard)

Description:	Discard timestamp.
Format:	Date
Version:	CCC 6.0.0
Notes:	Added if all delivery routes fail.
Example:	DISTS=20080901041706

DLOC (terminating party location information)

Description:	Specifies the terminating party location information
Format:	String
Version:	CCC 6.0.0
Notes:	This value will be set in the following order: <ul style="list-style-type: none"> Cell ID returned in the MAP_ATI response if available, Default MSC ID from the eserv.config parameter, "defaultTerminatingLocation", or A null value, if the Control Plan does not initiate a MAP-ATI for the called party.
Example:	

DLVR (message delivered flag)

Description:	Message delivered
Format:	Boolean
Version:	CCC 6.0.0

Notes:	0 - not delivered 1 - delivered This is only present on EDRs for delivery receipt messages.
Example:	DLVR=1

DPATH (delivery path)

Description:	Path used for outbound delivery/submit attempt
Format:	String
Version:	CCC 6.0.0
Notes:	
Example:	DPATH=SMPP_SME_SMPP1

DRM (drm content)

Description:	If the MMS contains DRM content present
Format:	Integer
Version:	CCC 6.0.0
Notes:	
Example:	DRM=1

DSCA (destination service center address)

Description:	Destination service center address.
Format:	Integer
Version:	CCC 6.0.0
Notes:	Service center address of the configured destination SMSC. Included only when MAP delivery to the SMSC is attempted.
Example:	

DSCGT (destination gt)

Description:	Destination global title.
Format:	String
Version:	CCC 6.0.0
Notes:	Global title of the configured destination SMSC. Included only when MAP delivery to the SMSC is attempted.
Example:	

DSTL (destination gt of fda msc)

Description:	Destination global title of FDA MSC.
Format:	String
Version:	CCC 6.0.0

Notes:	
Example:	

EDELTA (earliest delivery time)

Description:	The earliest delivery time
Format:	Integer
Version:	CCC 6.0.0
Notes:	The number of seconds since 1 Jan 1970
Example:	EDELTA=1354152268

ESN (electronic serial number)

Description:	Electronic serial number
Format:	32 bit "number", having a sub format of 14 bit manufacturer code and 18 bit serial number.
Version:	CCC 6.0.0
Notes:	Used with AMPS, TDMA and CDMA phones in the United States, equivalent to IMEI numbers used by all GSM phones.
Example:	

GPRS (general packet radio service)

Description:	General packet radio service supported indicator.
Format:	Boolean
Version:	CCC 6.0.0
Notes:	0 = GPRS not supported 1 = GPRS supported
Example:	GPRS=0

IPRI (incoming protocol value)

Description:	Incoming priority value
Format:	String
Version:	CCC 6.0.0
Notes:	
Example:	IPRI=PriorityNormal

IPRN (incoming protocol name)

Description:	Incoming protocol name
Format:	String
Version:	CCC 6.0.0
Notes:	For internally-generated delivery reports, the protocol name will be Wrapper .

Example:	IPRN=MAP
-----------------	----------

ITS (incoming tele service)

Description:	Incoming tele-service
Format:	
Version:	CCC 6.0.0
Notes:	
Example:	

MMC (mms message class)

Description:	The MMS message class
Format:	Integer
Version:	CCC 6.0.0
Notes:	0 - None 1 - Personal 2 - Advertisement 3 - Informational 4 - Automatic
Example:	MMC=1

MSCA (smsc address)

Description:	SMSC address
Format:	Refer to <i>EDR address format</i> .
Version:	CCC 6.0.0
Notes:	For an IS41 FDA delivery, the MSCA tag shows the MSC address used for the actual delivery attempt.
Example:	MSCA=tel:0040015114406267

MSGD (message destination)

Description:	Outbound/outgoing message destination
Format:	Integer
Version:	CCC 6.0.0
Notes:	0 – Short Message Entity, that is, direct delivery to handset or ASP 1 – Message Center
Example:	MSGD=1

MSGR (message reference number)

Description:	Message reference number
Format:	Integer

Version:	CCC 6.0.0
Notes:	
Example:	MSGR=5

MTYP (message type)

Description:	Incoming/inbound message type
Format:	Integer
Version:	CCC 6.0.0
Notes:	0 - Submit 1 - Deliver 2 - Notify 3 - Command 4 - RouteInfo
Example:	MTYP=1

NRQ (status report requested for message)

Description:	Was a notification (status report) requested for this message?
Format:	Boolean
Version:	CCC 6.0.0
Notes:	0 = not requested 1 = requested
Example:	NRQ=0

NRQD (emi with defined nrq)

Description:	EMI with defined NRQ
Format:	List
Version:	CCC 6.0.0
Notes:	This is an EMI only field. If the incoming EMI message has a defined NRQ, then the following will be appended: NRQD= <i>nrq</i> , , <i>npid</i> Note that npid may be "" if not present.
Example:	

OADR (originating address)

Description:	Originating address
Format:	Refer to <i>EDR address format</i> .
Version:	CCC 6.0.0
Notes:	
Example:	OADR=tel:0010006449393414

OAID (originating adapter id)

Description:	Originating adapter ID
Format:	String
Version:	CCC 6.0.0
Notes:	For all internally-generated delivery reports this will be MMX_INTERNAL_DR_ADAPTER .
Example:	OAID=MAP1

OCAU (acs cause value)

Description:	Cause value returned by ACS on originating call model.
Format:	
Version:	CCC 6.0.0
Notes:	
Example:	

OIMSI (originating imsi)

Description:	Originating IMSI (if present).
Format:	String
Version:	CCC 6.0.0
Notes:	
Example:	

OIPA (originating ip address)

Description:	Originating IP address
Format:	String
Version:	CCC 6.0.0
Notes:	
Example:	

OLOC (originating party location information)

Description:	Specifies the originating party location information.
Format:	String
Version:	CCC 6.0.0
Notes:	This value will be set in the following order: <ul style="list-style-type: none"> • Cell ID returned in the MAP_ATI response if available, • MSC ID from the SCCP layer if available • Default MSC ID from the <co_conf> parameter, defaultOriginatingLocation
Example:	

OPRI (outgoing priority)

Description:	Outgoing priority
Format:	String
Version:	CCC 6.0.0
Notes:	
Example:	OPRI=PriorityNormal

OPRN (output protocol name)

Description:	Output protocol name
Format:	String
Version:	CCC 6.0.0
Notes:	
Example:	OPRN=SMPP

OPRT (originating port number)

Description:	Originating port number
Format:	Integer
Version:	CCC 6.0.0
Notes:	
Example:	OPRT=

OSA (originator system address)

Description:	The originator system address of MMS messages
Format:	Refer to <i>EDR address format</i> .
Version:	CCC 6.0.0
Notes:	
Example:	OSA=0010013094219300

OTS (outgoing tele service)

Description:	Outgoing tele-service
Format:	
Version:	CCC 6.0.0
Notes:	
Example:	

PERR (protocol specific error)

Description:	Protocol specific error or abort
Format:	String

Version:	CCC 6.0.0
Notes:	<ul style="list-style-type: none"> • MAP: error-34, pabort-2, uabort-1 • SMPP: ESME_RSYSERR, ESME_RINVMMSGID • EMI: error-03, error-24 • IS41: error-0x81, error-0x8c
Example:	

PRES (terminating adapter response)

Description:	Terminating adapter response, whether the SMS was successfully delivered or not. (was - adapter response to Submit)
Format:	Integer
Version:	CCC 6.0.0
Notes:	1 – Success 2 – Failed 3 – Rejected
Example:	PRES=1

PRID (protocol identifier)

Description:	Protocol identifier. Provides any protocol specific information in an incoming message.
Format:	Integer
Version:	CCC 6.0.0
Notes:	
Example:	PRID=1

RECN (current recipient number)

Description:	The current recipient number. Which numbered destination address this message is for when dealing with a multi-destination message.
Format:	Integer
Version:	CCC 6.0.0
Notes:	
Example:	RECN=1

RECT (number of recipients)

Description:	The number of recipients for this message.
Format:	Integer
Version:	CCC 6.0.0
Notes:	
Example:	RECT=3

RESL (submit result)

Description:	Submit result. The response given to the A-party.
Format:	Integer
Version:	CCC 6.0.0
Notes:	0 – Success 1 – Transient Failure 2 – Permanent Failure 3 – Abort
Example:	RESL=0

RRR (read reply request)

Description:	The read reply request. If a read reply has been requested
Format:	Integer
Version:	CCC 6.0.0
Notes:	
Example:	RRR=1

SCA (service center address)

Description:	Service center address.
Format:	Refer to <i>EDR address format</i> .
Version:	CCC 6.0.0
Notes:	The value will be the same as either MSCA or DSCA depending on the message type.
Example:	SCA=0010013094219300

SCRID (screening rule id)

Description:	The screening rule ID in the EDR which identifies the filtering rule of the message.
Format:	Integer
Version:	CCC 6.0.0
Notes:	
Example:	SCRID=21

SEGN (message segment number)

Description:	The message was message segment <i>n</i> of a potentially segmented message.
Format:	Integer
Version:	CCC 6.0.0
Notes:	This is logged irrespective of segmentation or not of the message.
Example:	SEGN=0

SEGR (concatenated message reference)

Description:	Concatenated message reference
Format:	
Version:	CCC 6.0.0
Notes:	
Example:	

SEGT (total message segments)

Description:	The total number of message segments.
Format:	Integer
Version:	CCC 6.0.0
Notes:	This is logged irrespective of segmentation or not of the message.
Example:	SEGT=0

SRCL (source location)

Description:	SourceLocation Information, that is, VMSC address for MAP/IS-41.
Format:	
Version:	CCC 6.0.0
Notes:	E.164 of sending VMSC
Example:	SRCL=00001310:9

SRQ (storage requested)

Description:	If storage is requested of this MMS message
Format:	Integer
Version:	CCC 6.0.0
Notes:	
Example:	SRQ=1

SSAD (ip of originating smsc)

Description:	The IP address of originating SMSC
Format:	
Version:	CCC 6.0.0
Notes:	
Example:	

SSRID (screening sub-rule id)

Description:	The screening sub-rule ID in the EDR which identifies the sub-rule that filters the message.
---------------------	--

Format:	Integer
Version:	CCC 6.0.0
Notes:	
Example:	SSRID=1

SSTN (smpp service type)

Description:	The SMPP service type
Format:	
Version:	CCC 6.0.0
Notes:	
Example:	

STRR (status report request)

Description:	Status report request.
Format:	Integer
Version:	CCC 6.0.0
Notes:	0 - no report requested 1 - handset/asp request (for its own purposes) 2 - requested by MM (ACS), for billing purposes. 3 - requested by SME and MM.
Example:	STRR=0

SUBJ (message subject)

Description:	The message subject for MIME encoded messages
Format:	String
Version:	CCC 6.0.0
Notes:	
Example:	SUBJ=Lunch

SUB_STATUS (subscriber status)

Description:	The subscriber status
Format:	Integer
Version:	
Notes:	0 - subscriber information not retrieved 1 - unknown subscriber 2 - error 3 - active 4 - canceled
Example:	SUB_STATUS=0

SV (sender visibility)

Description:	The sender visibility property of MMS messages
Format:	Integer
Version:	CCC 6.0.0
Notes:	
Example:	SV=1

TAID (terminating adapter id)

Description:	Terminating adapter ID
Format:	String
Version:	CCC 6.0.0
Notes:	
Example:	TAID=SMPP1

TCAU (acs terminate cause value)

Description:	Cause value returned by ACS on terminating call model
Format:	Integer
Version:	CCC 6.0.0
Notes:	
Example:	

THRD (throttled flag)

Description:	1 if message is throttled, otherwise tag is absent
Format:	Integer
Version:	CCC 6.0.0
Notes:	
Example:	THRD=1

TLEN (length of user data in characters)

Description:	Length of the user data (that is, message) in characters.
Format:	Integer
Version:	CCC 6.0.0
Notes:	
Example:	TLEN=12

TYPE (type of edr)

Description:	Type of EDR; that is, where and why it was generated.
Format:	Integer

Version:	CCC 6.0.0
Notes:	1 - MO/MT short messages
Example:	TYPE=1

ULEN (length of user data)

Description:	Length of the user data (that is, message) in octets (bytes).
Format:	Integer
Version:	CCC 6.0.0
Notes:	
Example:	ULEN=11

USRD (user data)

Description:	Contains the user data.
Format:	See notes
Version:	CCC 6.0.0
Notes:	<p>If MM:</p> <ul style="list-style-type: none"> Can parse the user data into the UTF-8 alphabet, then the corresponding UTF-8 string will be displayed. In this case, the ULEN field denotes the number of bytes, which may differ from the number of contained alphabetic characters. Cannot convert the user data into a UTF-8, then the output will be displayed as a hex, using 00-FF to denote the content of each byte. In this case, ULEN will exactly match the number of bytes represented in the USRD field output. <p>Any control characters, if found, are converted as follows:</p> <ul style="list-style-type: none"> \n, \r, \f converted to ' ' (space) converted to !
Example:	USRD=Hello, whats up

VP (validity period)

Description:	<p>Validity period.</p> <p>The time period in seconds during which the originator considers the short message to be valid.</p>
Format:	Integer
Version:	CCC 6.0.0
Notes:	If this field is set to 0, then there is no time limit.
Example:	VP=0

Multiple field occurrences

Every delivery attempt will write the fields OPRN, TAID, MSCA, OADR, DADR, SRCL, OPRI, MSGD, STRR and PRES to the EDR.

If there is at least one attempt, the fields MSCA, OADR, DADR, SRCL, MSGD and STRR are written twice.

- Once when the incoming call is passed to Messaging Manager
- Once when termination is attempted

The fields are not necessarily the same though, as Messaging Manager/ACS can change the values. However, MSCA and SRCL are not present for all protocols.

Example EDR 1 (Remove11)

Here is an example MM EDR. It is an 7-bit GSM text message from 6449393414 to 6449393471 (MAP to SMPP). The message was normal priority, successfully delivered, unsegmented, with no delivery receipt requested.

```
TYPE=1|DATE=20080901041701|IPRN=MAP|OAID=MAP1|MSCA=0040015114406267|
OADR=0010006449393414|DADR=0020006449383471|IPRI=PriorityNormal|MTYP=0|MSGD=1|
SRCL=00001310:9|MSGR=0|USRD=Test Message|ALPH=GSM7Bit|ULEN=11|TLEN=12|PRID=0|STRR=0|VP=0|
NRQ=0|SEGN=0|SEGT=0|DELTS=20041214040046|OPRN=SMPP|TAID=SMPP1|MSCA=0040015114406267|
OADR=0010006449393414|DADR=0020006449393471|OPRI=PriorityNormal|MSGD=1|PRES=1|
SRCL=00001310:9|STRR=0|RESL=0
```

Example EDR 2 (Remove19)

This example EDR is a message from 6449393414 to 6449393471 (IS-41 to IS-41). The message was emergency priority GSM 7-bit text of "hello, how are you", successfully delivered, unsegmented, with no delivery receipt requested.

```
TYPE=1|DATE=20060901041701|IPRN=IS41|OAID=CDMA1|MSCA=0040015114406267|
OADR=0010006449393414|DADR=0020006449393471|IPRI=PriorityEmergency|MTYP=0|MSGD=1|
SRCL=00001310:9|MSGR=5|USRD=hello, how are you|ALPH=GSM7Bit|ULEN=33|TLEN=18|PRID=1|
STRR=0|VP=0|NRQ=0|SEGN=0|SEGT=0|DELTS=20041214040046|OPRN=IS41|TAID=CDMA1|
MSCA=0040015114406267|OADR=0010006449393414|DADR=0020006449393471|OPRI=PriorityEmergency|
MSGD=0|PRES=1|SRCL=00001310:9|STRR=0|RESL=0
```

Example EDR 3 (Remove15)

Here is an example EDR of a failed delivery receipt or a prior successful message. The delivery receipt failed because of a numberRules misconfiguration in Messaging Manager Navigator.

The call was an IS-41 to IS-41 delivery receipt from 6449393471 to 6449393414. The message was emergency priority GSM 7-bit text of "hello world."

```
TYPE=1|DATE=20060901041701|IPRN=IS41|OAID=CDMA1|MSCA=0040015114406267|
OADR=0020006449393471|DADR=0010006449393414|IPRI=PriorityEmergency|MTYP=1|DLVR=1|MSGD=0|
SRCL=00001310:9|MSGR=5|USRD=hello world.|ALPH=GSM7Bit|ULEN=11|TLEN=12|PRID=1|STRR=0|VP=0|
NRQ=0|SEGN=0|SEGT=0|DELTS=20041214040046|OPRN=IS41|TAID=CDMA1|MSCA=0040015114406267|
OADR=0020006449393471|DADR=0010006449393414|OPRI=PriorityEmergency|MSGD=0|PRES=1|
SRCL=00001310:9|STRR=0|RESL=1
```

EDR address format

Several EDR tags contain addresses. These tags include:

- MSCA
- OADR
- DADR

All addresses are specified using the following format:

(TON) (NPI) (Address Digits)

This table describes the components in the EDR Addresses.

Component	Explanation	Value
TON	The type of number value indicator. Where: 000 = unknown 001 = international 002 = national 003 = network_specific 004 = subscriber_number 005 = alphanumeric 006 = abbreviated	000 - 006
NPI	The number plan indicator value for the prefix. Where: 000 = unknown 001 = ISDN (E.163/E.164) 003 = Data (X.121) 004 = Telex (F.69) 006 = Land mobile (E.212) 008 = National 009 = Private 010 = ERMES 013 = Point Code & subscriber number 014 = Internet (IP) 018 = WAP	000 - 001, 003 - 004, 006, 008 - 010, 013- 014, 018
Address Digits	Addresses used include SMSC, originating, destination address and source location information.	

Example:

```
-MSCA=
00000148500000007
```

TON = 000 (unknown), NPI = 001 (isdn), Address digits = 48500000007

Note: Unless normalized otherwise, the EDR shows the TON and NPI as they are set in the incoming message. According to GSM specification (ETSI TS 100 901 V7.3.0).

UIS EDRs

Example of UIS EDR

```
UIS|callID=76598|sessionID=76598|type=0|IMSI=|MSISDN=<MSISDN>|dialledString=*1 23#|
SAN=*123#|servicelf=-2|operator=-1|mapPhase=2|fastAccess=0|interactions=2|
sessionTimeout=1|inactivityTimeout=0|ssfTimeout=0|startTime=20230317225047|ses
sionDuration=59.925618|RequestTime=2023-03-17 22:50:47.113833|
ResponseTime=2023-03-17 22:50:47.345163|trace=M10L1 S12L1
```

UIS EDR Tags

Here are the EDR tags produced by UIS.

IMSI

Description:	The IMSI (International Mobile Subscriber Identity) is a unique identifier for a mobile subscriber. It is compulsory for the generation of a CDR (Call Detail Record). If the IMSI is not available, a CDR will not be generated.
Format:	Up to 20 characters
Version:	
Notes:	
Example:	IMSI=310150123456789

MSISDN

Description:	The MSISDN (Mobile Station International Subscriber Directory Number) represents the phone number of the mobile subscriber. It may be populated depending on the processing stage reached. For a Send UCP CDR, the MSISDN is populated with the originating address of the UCP message.
Format:	Up to 15 characters
Version:	
Notes:	
Example:	MSISDN=1234567890

dialledString (Dialled String)

Description:	Represents the original dialed string entered by the subscriber. This value reflects the user's input for initiating the session.
Format:	Variable length (format to be defined at the design stage)
Version:	
Notes:	
Example:	DialledString=*123#

SAN (Subscriber Access Number)

Description:	The SAN (Subscriber Access Number) may be populated depending on whether it can be determined. For a Send UCP CDR, the SAN is populated with the destination address of the UCP message.
Format:	Up to 10 digits
Version:	
Notes:	
Example:	SAN=9876543210

servicelf (Service Interface)

Description:	This field indicates the service interface derived for the session. It may be populated depending on the SAN determination.
Format:	Up to 40 characters
Version:	
Notes:	
Example:	servicelf=-2

operator

Description:	Indicates the operator involved in the session. This field is populated if the operator is determined during processing.
Format:	Up to 20 characters
Version:	
Notes:	
Example:	operator=-1

fastAccess (Fast Access)

Description:	A flag indicating whether fast access was performed when the session was first initiated. The fast access feature must also be enabled for this field to be populated. For a Send UCP CDR, this field indicates the charge flag.
Format:	1 character (e.g., 0 or 1)
Version:	
Notes:	
Example:	fastAccess=0

interactions (Number of User Interactions)

Description:	Represents the total number of interaction attempts made by the user during the session.
Format:	Integer
Version:	
Notes:	
Example:	interactions=2

startTime (Start Time)

Description:	The start time of the session. This field is always populated.
Format:	20-character string (format to be defined at the design stage)
Version:	
Notes:	
Example:	startTime=20230317225047

sessionDuration (Session Duration)

Description:	Indicates the duration of the session in seconds. This field is always populated for USSD Gateway sessions.
Format:	20-character string (format to be defined at the design stage)
Version:	
Notes:	
Example:	sessionDuration=59.925618

sessionTimeout (Session Cutoff Timer Expiry)

Description:	Indicates whether the session cutoff timer expired.
Format:	Binary (0 or 1)
Version:	
Notes:	
Example:	SessionTimeout=1

ssfTimeout (SSF Timer Expiry)

Description:	Indicates whether the SSF (Service Switching Function) timer expired.
Format:	Binary (0 or 1)
Version:	
Notes:	
Example:	sessionTimeout=1

inactivityTimeout (Inactivity Timer Expiry)

Description:	Indicates whether the inactivity timer expired.
Format:	Binary (0 or 1)
Version:	
Notes:	
Example:	InactivityTimeout=0