

Oracle® Communications

EAGLE G-Port User's Guide



Release 46.9

F27986-01

August 2020



Oracle Communications EAGLE G-Port User's Guide, Release 46.9

F27986-01

Copyright © 1993, 2020, Oracle and/or its affiliates.

Primary Authors: (primary author), (primary author)

Contributing Authors: (contributing author), (contributing author)

Contributors: (contributor), (contributor)

This software and related documentation are provided under a license agreement containing restrictions on use and disclosure and are protected by intellectual property laws. Except as expressly permitted in your license agreement or allowed by law, you may not use, copy, reproduce, translate, broadcast, modify, license, transmit, distribute, exhibit, perform, publish, or display any part, in any form, or by any means. Reverse engineering, disassembly, or decompilation of this software, unless required by law for interoperability, is prohibited.

The information contained herein is subject to change without notice and is not warranted to be error-free. If you find any errors, please report them to us in writing.

If this is software or related documentation that is delivered to the U.S. Government or anyone licensing it on behalf of the U.S. Government, then the following notice is applicable:

U.S. GOVERNMENT END USERS: Oracle programs (including any operating system, integrated software, any programs embedded, installed or activated on delivered hardware, and modifications of such programs) and Oracle computer documentation or other Oracle data delivered to or accessed by U.S. Government end users are "commercial computer software" or "commercial computer software documentation" pursuant to the applicable Federal Acquisition Regulation and agency-specific supplemental regulations. As such, the use, reproduction, duplication, release, display, disclosure, modification, preparation of derivative works, and/or adaptation of i) Oracle programs (including any operating system, integrated software, any programs embedded, installed or activated on delivered hardware, and modifications of such programs), ii) Oracle computer documentation and/or iii) other Oracle data, is subject to the rights and limitations specified in the license contained in the applicable contract. The terms governing the U.S. Government's use of Oracle cloud services are defined by the applicable contract for such services. No other rights are granted to the U.S. Government.

This software or hardware is developed for general use in a variety of information management applications. It is not developed or intended for use in any inherently dangerous applications, including applications that may create a risk of personal injury. If you use this software or hardware in dangerous applications, then you shall be responsible to take all appropriate fail-safe, backup, redundancy, and other measures to ensure its safe use. Oracle Corporation and its affiliates disclaim any liability for any damages caused by use of this software or hardware in dangerous applications.

Oracle and Java are registered trademarks of Oracle and/or its affiliates. Other names may be trademarks of their respective owners.

Intel and Intel Inside are trademarks or registered trademarks of Intel Corporation. All SPARC trademarks are used under license and are trademarks or registered trademarks of SPARC International, Inc. AMD, Epyc, and the AMD logo are trademarks or registered trademarks of Advanced Micro Devices. UNIX is a registered trademark of The Open Group.

This software or hardware and documentation may provide access to or information about content, products, and services from third parties. Oracle Corporation and its affiliates are not responsible for and expressly disclaim all warranties of any kind with respect to third-party content, products, and services unless otherwise set forth in an applicable agreement between you and Oracle. Oracle Corporation and its affiliates will not be responsible for any loss, costs, or damages incurred due to your access to or use of third-party content, products, or services, except as set forth in an applicable agreement between you and Oracle.

Contents

1 Introduction

1.1	Overview	1-1
1.2	Scope and Audience	1-1
1.3	Manual Organization	1-1
1.4	Related Publications	1-2
1.5	Locate Product Documentation on the Oracle Help Center Site	1-2

2 Feature Description

2.1	Introduction	2-1
2.2	G-Port Protocol	2-9
2.2.1	Main Functions	2-9
2.2.2	G-Port Call Flows	2-18
2.3	Network Perspectives	2-24
2.4	G-Port Considerations	2-26
2.5	General Numbering Requirements	2-28
2.6	G-Port SCCP Service Re-Route Capability	2-28
2.7	MT-Based GSM SMS NP	2-32
2.7.1	Options	2-33
2.7.2	Feature Control Requirements	2-33
2.7.3	System Options for MT-Based GSM SMS NP	2-33
2.7.4	MT-Based GSM SMS and MMS NP Call Flows	2-40
2.8	MT-Based GSM MMS NP	2-42
2.8.1	Options	2-43
2.8.2	Feature Control Requirements	2-43
2.8.3	System Options for MT-Based GSM MMS NP	2-43
2.8.4	MT-Based GMS MMS NP Call Flows	2-46
2.9	G-Port SRI Query for Prepaid	2-46
2.10	GSM MAP SRI Redirect to Serving HLR	2-49
2.11	Hardware Requirements	2-52
2.12	MPS/EPAP Platform	2-52

3 Commands

3.1	Introduction	3-1
3.2	EAGLE Options Commands	3-1
3.3	EAGLE GSM Options Commands	3-1
3.4	EAGLE GSM SMS Options Commands	3-4
3.5	EAGLE G-Port Service Selector Commands	3-6
3.6	EAGLE SCCP Service Commands	3-8
3.7	EAGLE Feature Control Commands	3-9

4 Feature Configuration

4.1	Introduction	4-1
4.2	EPAP Entity Provisioning	4-2
4.3	Prerequisites	4-2
4.4	EAGLE HLR Configuration	4-3
4.5	G-Port Feature Activation Procedure	4-10
4.6	MT-Based GSM SMS NP Feature Activation Procedure	4-13
4.7	MT-Based GSM MMS NP Feature Activation Procedure	4-15
4.8	G-Port SRI Query for Prepaid Feature Activation Procedure	4-16
4.9	GSM MAP SRI Redirect to Serving HLR Feature Activation Procedure	4-18

5 Measurements

5.1	G-Port Measurements	5-1
-----	---------------------	-----

6 Maintenance

6.1	G-Port Related Alarms	6-1
6.2	G-Port Related UIMs	6-1
6.3	Maintenance Commands	6-3
6.3.1	rept-stat-sccp	6-5
6.4	Debug Commands	6-5
6.5	Status Reporting and Problem Identification	6-6
6.5.1	EPAP Status and Alarm Reporting	6-7
6.5.2	Hourly Maintenance Report	6-9

My Oracle Support

[My Oracle Support \(MOS\)](#) is your initial point of contact for any of the following requirements:

- **Product Support:**

The generic product related information and resolution of product related queries.

- **Critical Situations**

A critical situation is defined as a problem with the installed equipment that severely affects service, traffic, or maintenance capabilities, and requires immediate corrective action. Critical situations affect service and/or system operation resulting in one or several of these situations:

- A total system failure that results in loss of all transaction processing capability
- Significant reduction in system capacity or traffic handling capability
- Loss of the system's ability to perform automatic system reconfiguration
- Inability to restart a processor or the system
- Corruption of system databases that requires service affecting corrective actions
- Loss of access for maintenance or recovery operations
- Loss of the system ability to provide any required critical or major trouble notification

Any other problem severely affecting service, capacity/traffic, billing, and maintenance capabilities may be defined as critical by prior discussion and agreement with Oracle.

- **Training Need**

Oracle University offers training for service providers and enterprises.

A representative at Customer Access Support (CAS) can assist you with [MOS](#) registration.

Call the CAS main number at 1-800-223-1711 (toll-free in the US), or call the Oracle Support hotline for your local country from the list at [Oracle Support Contacts](#). The emergency response provides immediate coverage, automatic escalation, and other features to ensure that the critical situation is resolved as rapidly as possible.

When calling, make the selections in the sequence shown below on the Support telephone menu:

1. Select 2 for New Service Request
2. Select 3 for Hardware, Networking and Solaris Operating System Support
3. Select one of the following options:
 - For Technical issues such as creating a new Service Request (SR), Select 1
 - For Non-technical issues such as registration or assistance with MOS, Select 2

You will be connected to a live agent who can assist you with MOS registration and opening a support ticket.

MOS is available 24 hours a day, 7 days a week, 365 days a year.

What's New in This Guide

There are no updates in this document for Release 46.9.

1

Introduction

This chapter provides a brief description of the G-Port feature of the Oracle Communications EAGLE. The chapter also includes the scope, audience, and organization of the manual; how to find related publications; and how to contact Oracle for assistance.

1.1 Overview

This manual provides an overview of the **GSM Mobile Number Portability (G-Port)** feature of the Oracle Communications EAGLE. The G-Port feature implements **Mobile Number Portability** for **GSM** networks according to **ETSI GSM 03.66**. In response to governmental mandates for telecommunication networks, this feature focuses on service provider number portability on GSM networks.

G-Port minimizes the challenges for GSM network operators while enabling them to meet regulatory obligations. G-Port supports the Signaling Relay Function (**SRF**) for direct and indirect routing. SRF-based Mobile Number Portability (**MNP**) processing examines **MAP** messages for ported numbers. For call-related messages, G-Port acts as an NP HLR for exported number by responding with a MAP **SRI** message; G-Port performs a message relay function for calls to imported numbers and non-call related messages.

The G-Port feature allows subscribers to be moved easily from one Home Location Register (**HLR**) to another. The G-Port feature applies to **ANSI**, **ITU-I** (international), and **ITU-N** (national) networks.

1.2 Scope and Audience

This manual is intended for anyone responsible for installing, maintaining, and using the **G-Port** feature of Oracle Communications EAGLE. Users of this manual and the others in the EAGLE family of documents must have a working knowledge of telecommunications and network installations.

1.3 Manual Organization

This document is organized into the following chapters:

- [Introduction](#) contains general information about the **G-Port** documentation, the organization of this manual, and how to request technical assistance.
- [#unique_14](#) provides a description of the G-Port feature and related features, including network perspectives, assumptions and limitations, database overview, Service Module card provisioning and reloading, and G-Port protocol.
- [Commands](#) describes the commands that support the G-Port and related features.
- [Feature Configuration](#) describes how to activate the G-Port feature and related features.

- [Measurements](#) describes the measurements information available for G-Port.
- [Maintenance](#) describes G-Port maintenance information including Oracle Communications EAGLE Application Processor (EPAP) status and alarms, hardware verification messages, system status reports and commands, code and application data loading, and alarms.

1.4 Related Publications

For information about additional publications related to this document, refer to the Oracle Help Center site. See [Locate Product Documentation on the Oracle Help Center Site](#) for more information on related product publications.

1.5 Locate Product Documentation on the Oracle Help Center Site

Oracle Communications customer documentation is available on the web at the Oracle Help Center (OHC) site, <http://docs.oracle.com>. You do not have to register to access these documents. Viewing these files requires Adobe Acrobat Reader, which can be downloaded at <http://www.adobe.com>.

1. Access the Oracle Help Center site at <http://docs.oracle.com>.
2. Click `Industries`.
3. Under the Oracle Communications subheading, click the `Oracle Communications documentation` link.

The Communications Documentation page appears. Most products covered by these documentation sets will appear under the headings "Network Session Delivery and Control Infrastructure" or "Platforms."

4. Click on your Product and then the Release Number.
A list of the entire documentation set for the selected product and release appears.
5. To download a file to your location, right-click the `PDF` link, select `Save target as` (or similar command based on your browser), and save to a local folder.

2

Feature Description

This chapter describes the G-Port feature and related features which include:

- MT-Based GSM SMS NP
- MT-Based GSM MMS NP
- G-Port SRI Query for Prepaid
- GSM MAP SRI Redirect to Serving HLR

2.1 Introduction

Throughout the world, an increasing number of governments are mandating that telecommunications network operators support service provider number portability. These mandates are intended to promote competition among service providers and apply to both wireline and mobile phone networks. The **GSM Mobile Number Portability (G-Port)** feature is focused on service provider portability in **GSM** (Global System for Mobile Communications) networks.

Service provider portability allows a consumer to change service providers while retaining the same phone number. While consumers benefit from number portability, the implementation can present challenges for network operators. G-Port minimizes the challenges for GSM network operators, while enabling them to efficiently meet their regulatory obligations.

G-Port implements Mobile Number Portability for GSM networks according to the **ETSI GSM 03.66** standard. The focus is on service provider portability among GSM networks in a defined portability cluster, usually a country. With service provider portability, subscribers can change operators while retaining their MSISDNs (Mobile Station international ISDN number). The **MSISDN** is the number dialed by a caller trying to reach the subscriber. The **IMSI** (International Mobile Station Identifier) number is not portable. The IMSI identifies the **SIM** (Subscriber Identity Module) card, which plugs in as a module to the GSM handset.

The G-Port feature is based on the EAGLE platform, and is deployed in a node that is also performing the STP function. G-Port uses the Real Time Database (RTDB) to derive the portability status of subscribers.

MNP Circular Route Prevention

The **MNP Circular Route Prevention (MNPCRP)** feature detects circular routing caused by incorrect information in one or more of the network number portability databases. For example, a subscriber may have ported from network A to network B. Network A has the correct routing information, indicating the subscriber now belongs to network B. However, network B may have incorrect routing information, indicating that the subscriber still belongs to network A. In this case, network A routes the call to network B, based on its portability data, but network B routes the call back to network A, based on its incorrect data. The result is a circular route. The MNPCRP feature provides logic to prevent the circular routing from occurring.

The MNP Circular Route Prevention feature (MNPCRP) is enhanced to allow Circular Route Prevention based on the Translation Type (TT) of the SCCP CdPA to be performed for SRI messages when a Home Routing Number (HomeRN) is not present. For the Circular Route Prevention on Translation Type processing to be performed, the `crptt` parameter of the `chg-gsmopts` command must be set to a value between 0 and 255. If the `crptt` parameter of the `chg-gsmopts` command is set to the default value of `none`, then no Circular Route Prevention on Translation Type processing is performed. The MNP Circular Route Prevention feature cannot be turned off if the `crptt` parameter is provisioned to any value other than `none`. If a message is processed for Circular Route Prevention based on HomeRN, then Circular Route Prevention on Translation Type processing does not occur.

SRI messages must meet these criteria to be eligible for Circular Route Prevention on Translation Type:

- The message is selected for G-Port or IS41 GSM Migration processing.
- The message is not identified as G-Port SRI Query for Prepaid.
- The message is not MTP-routed. (The CdPA is Route-on-GT.)
- The translation type of the SCCP CdPA matches the provisioned translation type (`crptt`).
- The ITU TCAP Package type is ITU Begin.
- The OpCode is an SRI (hexadecimal 16).
- The Optimal Routing Interrogation Parameter (Tag = 0x04) is not present.
- The MSISDN is not assigned to the subscriber's network provider.

DigitAction Expansion

The DigitAction Expansion feature provides more flexibility to formulate the SCCP Called Party Address - Global Title Address (GTA) field of the MAP messages relayed by G-Port. Without DigitAction Expansion, G-Port supports four options (`none`, `insert`, `prefix`, and `replace`) to overwrite the SCCP CdPA GTA field. With DigitAction Expansion, four additional options (`delcc`, `delccprefix`, `spare1`, and `spare2`) are included to overwrite the SCCP CdPA GTA field.

DigitAction Expansion is provisioned via the PDBI Enter Network Entity or Update Network Entity commands. DigitAction Expansion can also be modified via the Add an NE and Update an NE GUI screens.

Digit Action DELCCPREFIX

The Digit Action to delete country code if present and prefix database entity feature allows the DELCCPREFIX Digit Action to be applied to the Called Party Global Title Address (CdPA GTA) when the GTA has a National format, as well as when the GTA has an International format. The DELCCPREFIX option in the SCCPOPTS table specifies how the DELCCPREFIX digit action is applied to a Called Party Global Title Address (CdPA GTA).

- When the SCCPOPTS:DELCCPREFIX option is set to `PFXWCC`, the DELCCPREFIX digit action is applied to the CdPA GTA only when the address has a International format. The Country Code is deleted and the GTA is prefixed with the Entity ID.
- When the SCCPOPTS:DELCCPREFIX option is set to `PFX4ALL`, the DELCCPREFIX digit action is applied to the CdPA GTA in all cases. For an

International format, the Country Code is deleted and the GTA is prefixed with the Entity ID. For a National format, the GTA is prefixed with the Entity ID.

The `chg-sccpopts` command is used to specify the `delccprefix` parameter value to configure the DELCCPREFIX Digit Action functionality.

G-Port SCCP Service Re-Route

The G-Port SCCP Service Re-Route feature is used when the G-Port subscriber database is incoherent with MPS data and the GTT data is valid. The G-Port SCCP Service Re-Route feature provides the capability to re-route the traffic from the EAGLE to other G-Port subscriber database nodes and inform the originating nodes to re-route the G-Port service related traffic to other G-Port service nodes.

The G-Port SCCP Service Re-Route feature is designed to handle and control re-routing of G-Port traffic from an affected node to alternate nodes within an operators network. This feature is an optional feature and does not affect the normal G-Port functionality. This feature also provides the option to mark G-Port offline to perform a controlled re-routing during this state.

Multiple Country Code

The Multiple Country Code (**MULTCC**) feature supports up to 10 MULTCCs for customers having one MNP node servicing several countries, or areas with differing country codes. The MULTCCs are not used for conditioning of non-International numbers to International format for database lookup. The MULTCCs are used for the construction of the Mobile Station Roaming Number (MSRN) parameter in the case of a Send Routing Information acknowledgement (**SRI Ack**) message from G-Port, and in certain cases for the formulation of the SCCP CdPA. The EFCC parameter in **STPOPTS** is used for conditioning of numbers to International format when necessary, and also for constructing the MSRN and SCCP CdPA parameters in addition to a MULTCC list. The MULTCC list is optional. If no values are provisioned, G-Port uses the DEFCC to process messages. If values are provisioned, G-Port automatically uses both the DEFCC and the MULTCC to process messages. The `chg-gsmopts` command along with the MULTCC and **NMULTCC** parameters are used to provision Multiple Country Code list entries.

MSISDN Truncation Support for G-Port

The MSISDN Truncation Support for G-Port feature is an optional feature that allows an operator to specify a certain number of digits to be deleted from the beginning of the National MSISDN (MSISDN without Country Code) prior to formulating the MSRN parameter of the SRI Ack message. This feature only changes the behavior of the encoding of the MAP MSRN parameter in an SRI Ack message formulated by the EAGLE. It does not affect the encoding of any other parameters or any other messages processed by G-Port. The International MSISDN is 12 digits long, and the RN is 5 digits long. So when the RN is added to form the MSRN parameter, it will exceed 15 digits in length. Some carriers require MSISDN digits to be truncated when formulating the MSRN parameter of SRI Ack message in G-Port to maintain a maximum length of 15 digits. This feature works in conjunction with the MULTCC Support feature. The DefCC and MULTCC table are used to determine which digits are the CC and which digits are the National MSISDN. If a match is not found on the leading digits of the International MSISDN, then the truncation is not performed and standard G-Port processing is followed. The `chg-gsmopts` command along with the **MISDNTRUNC** parameter is used to set-up the MSISDN Truncation Support feature.

Mobile-Originated Based GSM SMS Number Portability

The MO-Based GSM SMS NP feature provides network information to the Short Message Service Center (SMSC) for subscribers using the GSM network. This information allows the SMSC to select a protocol to deliver **SMS** messages to the called party. For more information about the MO-Based GSM SMS NP feature, refer to *MO SMS User's Guide*.

Mobile-Terminated Based GSM SMS Number Portability

The Mobile Terminated (**MT**)-Based GSM SMS NP feature allows wireless operators to route short message service (SMS) messages destined to mobile subscribers within a number portability (NP) environment. If the MT-Based GSM SMS NP feature is not enabled and turned on, then messages are processed by the G-Port feature.

In general, there are two kinds of messages of concern to number portability: call related and non-call related. The call-related messages query the HLR in real time for delivering the call to the subscriber. The G-port feature handles these.

Non-call related messaging involves the Short Message Service Center (**SMSC**) querying the HLR for the destination subscriber for SMS delivery. For SMS, these query messages are called SRI_SM. The HLR responds to these messages with routing information that can be used by the querying node (SMSC) to deliver the SMS message. In this feature, the EAGLE intercepts SRI_SM messages destined to the HLR and replies with routing information for out-of-network destination subscribers.

The MT-Based GSM SMS NP feature intercepts SRI_SM messages and replies with routing information for out-of-network destination subscribers using the following process:

1. An SRI_SM message from the SMSC is intercepted by the EAGLE before the message reaches the home location register (**HLR**).
2. The message destination address (SCCP Called Party GTA), is extracted, the digits are conditioned, and lookup is performed in the Real Time Database (RTDB).
3. If the destination address/subscribers belongs to a foreign network, then a reply message is sent to the SMSC with routing information. If the destination address/subscribers belongs to a local network, then the SRI_SM message is relayed to the HLR according to the options set for normal G-Port processing.

The feature provides configurable options for controlling processing of SRI_SM messages and the content of the response:

- Selecting the SMSC response message type and digit format
- Specifying when an RTDB lookup is considered to be successful
- Specifying the format of digits encoded in the response message.

Mobile-Terminated Based GSM MMS Number Portability

The MT-Based GSM MMS NP feature provides routing information to the Multimedia Message Service Center (**MMSC**) for subscribers using the GSM network. This information can be used by the MMSC to route the MMS messages to the called party.

 **Note:**

The MT-Based GSM MMS NP feature can be used only in conjunction with the MT-Based GSM SMS NP feature.

The MT-Based GSM MMS NP feature intercepts SRI_SM messages and replies with routing information for out-of-network destination subscribers using the following process:

1. An SRI_SM message from the MMSC is intercepted by the EAGLE before the message reaches the home location register (HLR).
2. The message destination address (SCCP Called Party GTA), is extracted, the digits are conditioned, and lookup is performed in the RTDB.
3. If the destination address/subscribers belongs to a foreign network, then a reply message is sent to the MMSC with routing information. If the destination address/subscribers belongs to a local network, then the SRI_SM message is relayed to the HLR according to the options set for normal G-Port processing.

The feature provides the following configurable options for controlling processing of SRI_SM messages and the content of the response:

- Selecting the MMSC response message type and digit format
- Specifying when an RTDB lookup is considered to be successful
- Specifying the format of digits encoded in the response message.

Routing Options

The ETSI standards for **SRF**-based MNP define two routing options, direct routing and indirect routing. G-Port supports both options:

- With direct routing, the network where the call is originated is responsible for determining whether the called party has ported and routing the call to the new subscription network.
- With indirect routing, this is the responsibility of the network that originally owned the number.

Dialed Number Lengths

Number lengths vary between countries and may even vary within a country. As a result, the G-Port subscriber database structure supports numbers of varying length in a flexible way without necessitating software modifications. A maximum number length of 15 digits for ported numbers is supported. This length is based on the maximum length for MSISDN numbers as defined in the ETSI GSM 03.03 standard.

SRF vs INAP Mobile Number Portability

The **ETSI** standards are defined so that GSM carriers can choose to implement either Signaling Relay Function (**SRF**)-based (using MAP protocol) MNP or **IN**-based (using INAP protocol) MNP. G-Port supports only the **SRF**-based solution for MNP. (INAP-based MNP processing is similar to wireline networks; this function is supported by the INP feature.)

SRF-based MNP processing involves intercepting existing MAP messages to check for ported numbers. For call-related messages, G-Port acts as an NP HLR in the case

where the number has been exported, by responding to the switch with a MAP SRI Ack message. For calls to imported numbers and non-call related messages, G-Port performs message relay.

G-Port SRI Query for Prepaid

The G-Port SRI Query for Prepaid feature allows the EAGLE to provide portability information to a Service Control Point (SCP) database. This information enables the database to determine the network used by a called subscriber. The G-Port SRI Query for Prepaid feature enables the following Message Signal Unit (MSU) values to be provisioned in the EAGLE GSERV table:

- translation type (TT)—The TT of the called party (CdPA)
- originating point code (OPC)—The OPC from the message transfer part (MTP) layer
- global title address (GTA)—The GTA of the calling party (CgPA)

These values are used to determine whether an SRI should receive G-Port SRI Query for Prepaid service or normal G-Port SRI service.

Service Portability (S-Port) support for the G-Port SRI Query for Prepaid feature allows subscribers to retain their same subscriber numbers after moving between different network technologies (example: IS41 and GSM) within the same operator. Service Portability applies to only **own-network** subscribers.

GSM MAP SRI Redirect to Serving HLR

The GSM MAP SRI Redirect to Serving HLR feature provides the capability to resolve the incompatibility introduced by the proprietary implementation of the GSM MAP SRI message. This feature is an extension to the G-Port protocol. The GSM MAP SRI Redirect to Serving HLR feature is compatible with other G-Port enhancement features.

Additional Subscriber Data Support

The G-Port feature is enhanced to support new Mobile Station Routing Number (MSRN) formatting options that use **Additional Subscriber Data (ASD)**. ASD information is inserted into the outgoing SRI Ack messages. If the GSMOPTS:MSRNDIG digit formatting option specifies the use of ASD information and a successful database lookup returns ASD, then the ASD is encoded into the outgoing message and the existing behavior for encoding messages for G-Port is followed.

ROP Support

The G-Port feature allows **Small Geographic Areas (CNLs)** to be grouped into **Large Geographic Areas (ROPs)**. This grouping simplifies the routing and allows a call to be delivered as close to the interconnection destination as possible. ROP information is stored in the **Generic Routing Number (GRN)** field. Both CNL and ROP information can be provisioned for a single subscriber entry; however, only one of the CNL or ROP fields can be selected for the outgoing message.

The G-Port SRI Query for Prepaid, SRI Redirect, IS41 GSM Migration (IGM), AINPQ, INP, and ATINP features also support ROP.

Include Optional CUG Parameter in SRI Ack Messages

The Include Optional **CUG** Parameter in SRI Ack Messages functionality allows an existing **Closed User Group-CheckInfo** (CUG-CheckInfo) parameter in an incoming SRI message to be included in the outgoing SRI Ack message.

The Include Optional CUG Parameter in SRI Ack Messages functionality is controlled by the `encodecug` option of the `chg-gsmopts` command `off` and `on` parameters. The `encodecug` option of the `chg-gsmopts off/on` parameter can be changed only if the G-Port or IGM feature is enabled.

The CUG-CheckInfo parameter in an incoming SRI message is copied in the original sequence to the outgoing SRI Ack message when these conditions are met:

- The `encodecug` option of the `chg-gsmopts` command is set to `on`.
- The CUG-CheckInfo parameter is present in an incoming SRI message.
- The CUG-CheckInfo parameter in an incoming SRI message is encoded in definite length format that is less than or equal to 30 bytes.

If the three conditions described above are met, the original CUG-CheckInfo sequence from the incoming SRI message is copied into the SRI Ack message. If encoded in the SRI Ack message, the CUG-CheckInfo parameter is located after the MSRN (Tag = 0x04) and before the MSISDN (Tag = 0x8C) or NPS parameter (Tag = 0x8D), if either MSISDN or NPS parameter is present. The CUG-CheckInfo parameter in an SRI Ack message uses Tag = 0xA3.

If the CUG-CheckInfo parameter is greater than 30 bytes and all other conditions for encoding are met, then only the CUG-Interlock and CUG-OutgoingAccess parameters are copied from an incoming SRI message to the outgoing SRI Ack message. The ExtensionContainer is omitted.

When the `encodecug` option is set to `off`, the CUG-CheckInfo parameter is not encoded in the SRI Ack message.

If the `encodecug` option is set to `on` but the CUG-CheckInfo parameter in an incoming SRI message uses an indefinite length format, the CUG-CheckInfo parameter is not encoded in the SRI Ack message.

Route SRI_SM and ReportSMSDeliveryStatus for Non-local or Ported-out Subscribers using GTT

The Route SRI_SM and ReportSMSDeliveryStatus for Non-local or Ported-out Subscribers using GTT functionality modifies SRI_SM and ReportSMSDeliveryStatus messages to allow routing of the message to an alternate network using Global Title Translation (GTT). This functionality allows processing to occur when the Directory Number (DN) in the database is associated with both the Service Point (SP) and Generic Routing Number (GRN) network elements and the GRN is not present in the EAGLE HomeRN table, or when the subscriber is ported out and associated with the Routing Number (RN).

The message is altered by changing the SCCP Called Party Address (CdPA) to the Country Code (CC) + GRN + DN or to CC + RN + DN. This alteration allows GTT to redirect the query to an alternate network. If a CC is not located in the DN, then the SCCP CdPA is converted to a GRN + DN or RN + DN format.

This conversion is performed only on ITU TCAP Begin MSUs with Op Code of SRI_SM or ReportSMSDeliveryStatus delivered to the GPort or MNP service selector

for processing. If the MT-Based GSM SMS NP feature or the IS41 GSM Migration (IGM) feature generates a response for the SRI_SM message, then this functionality is not applicable.

The Route SRI_SM and ReportSMSDeliveryStatus for Non-local or Ported-out Subscribers using GTT functionality is controlled by the `srismgttrtg` option of the `chg-gsmopts` command `off` and `on` parameters. The `srismgttrtg` option of the `chg-gsmopts off/on` parameter can be changed only if the G-Port or IGM feature is enabled.

Option to Suppress NumberPortabilityStatusIndicator in SRI Ack

The Option to Suppress NumberPortabilityStatusIndicator in SRI Ack functionality allows the Number Portability Status Indicator (NPSI) to be omitted from all SRI Ack messages.

The Option to Suppress NumberPortabilityStatusIndicator in SRI Ack functionality is controlled by the `encodenps` option of the `chg-gsmopts` command `off` and `on` parameters. The `encodenps` option of the `chg-gsmopts off/on` parameter can be changed only if the G-Port or IGM feature is enabled. The default setting of the `encodenps` option is `on`.

The NumberPortabilityStatusIndicator parameter is encoded in an SRI Ack message when these conditions are met:

- The `encodenps` option of the `chg-gsmopts` command is set to `on`.
- SRI is considered MAP Phase 2+.
- DN Portability Type is 0, 1, 2, or 36. (Portability Type = 36 is encoded as Portability Type = 0.)



Note:

MAP Phase is set based on the dialog portion, unless the dialog portion does identify. If the dialog portion does not identify, then the MAP Phase is based on GSMOPTS:DEFMAPVR.

The NumberPortabilityStatusIndicator parameter is not encoded in any SRI Ack message if the `encodenps` option of the `chg-gsmopts` command is set to `off`.

G-Port Considerations

- G-Port can be turned on, but cannot be turned off.
- The G-Port, A-Port, IGM, G-Flex C7 Relay, INP, and AINPQ features can run concurrently on an EAGLE node.
- When G-Port and G-Flex run on the same node, interactions between the two features must be addressed.
- G-Port and North American LNP are mutually exclusive on an EAGLE node, unless the Dual ExAP Configuration feature is enabled.
- G-Port SCCP Service Re-Route Capability is not supported for the Prepaid Short Message Service Intercept feature.

- G-Port, A-Port, or IGM must be turned on before the MNP Circular Route Prevention feature can be turned on.

2.2 G-Port Protocol

2.2.1 Main Functions

G-Port and MNPCRCP provide these main functions:

Message Discrimination

Because the G-Port feature provides translation of ported numbers, the feature provides a method to identify which messages should receive G-Port or GTT. This task of identification is provided by a service selector table in which the user can define G-Port service for a combination of selectors. If a selector match is not found then, G-Port falls through to GTT.

RN Prefix Deletion - SCCP

The decoded SCCP CdPA digits can have a RN concatenated with the MSISDN number in two forms:

- RN + DN
- CC+RN+DN

When the SNAI is either RNIDN, RNNDN, or RNSDN, G-Port compares the decoded MSISDN number with the list of provisioned home RN prefixes defined in the RTDB. If a match is found, G-Port removes the RN digits from the number.

Number conditioning, if required, is performed after deleting the RN.

When the SNAI is CCRNDN, G-Port first compares the CC to the DEFCC/MULTCC list:

- If CC is not equal to the DEFCC/MULTCC, then no prefix deletion is performed and G-Port processing continues.
- If CC=DEFCC/MULTCC then, G-Port compares the digits after CC with the list of provisioned Home RN prefixes that are defined in the RTDB. If a match is found, then G-Port strips off the RN digits from the number. If no match is found, the no-prefix deletion is performed and G-Port processing continues.

RN Prefix Deletion - TCAP

The decoded MAPMSISDN digits can have a RN concatenated with the **MSISDN** number in two forms:

- RN + DN
- CC+RN+DN

The MAP NAI is used to determine the type: International, National or Subscriber. If MNPCRCP is OFF, RN prefix deletion is not attempted. If MNPCRCP is ON, then RN prefix deletion is attempted on all MSISDNs. If the MAPNAI indicates International, then a check is performed for the DEFCC/MULTCC prefix on the MSISDN. If DEFCC/MULTCC is detected, then HomeRN deletion is attempted using the CC+RN+DN format. All other MSISDNs will use the RN+DN format. G-Port compares the decoded

MSISDN number with the list of provisioned home RN prefixes defined in the RTDB. If a match is found, the G-Port strips off the RN digits from the number.

Number conditioning, if required, is performed after deleting the RN.

If CC+RN+DN search is performed, G-Port compare the digits after CC with the list of provisioned home RN prefixes defined in the RTDB. If a match is found, G-Port strips off the RN digits from the number. If no match is found, then no prefix deletion is performed and G-Port processing continues.

Number Conditioning

The RTDB stores international MSISDNs only. The received MSISDN number or SCCP CdPA digits may need to be converted to an international number to perform a database lookup.

When G-Port is required to be performed on a message and the number is not international (that is, the NAI of MSISDN number is “National (Significant) Number” or “Subscriber Number”, or the SNAI is NATL or SUB or RNNNDN or RNLDN), the National/Local to International number is triggered.

For a National (Significant) Number, the received CdPA/MAP MSISDN digits are prepended with the default country code; for a Subscriber number, the CdPA/MAP MSISDN digits are prepended with the default country code and the default network code.

Database Lookup

G-Port performs an RTDB lookup using the MSISDN in international format. RTDB individual subscriber records have precedence over subscriber range records. If the MSISDN does not represent an individual subscriber in the RTDB, then the subscriber range records are searched. If the MSISDN is not represented by an individual subscriber record or by a subscriber range record in the RTDB, then the RTDB lookup fails.

If the first RTDB lookup fails but the MSISDN contains an even number of digits, ends with zero, and does not include a method for determining the exact number of digits (for example, an odd/even indicator), then the G-Port repeats the RTDB lookup using the MSISDN without the last digit.

If both RTDB lookup attempts fail, then G-Port does not process the message further; the message is passed to GTT to be routed out of the EAGLE.

Since a DN may be the target of the A-Port, G-Port, or IS41 GSM Migration (IGM) message processing in a hybrid network, where an operator owns both GSM and IS41 networks, message processing call disposition is based on which applications are turned on. [Table 2-1](#) shows call dispositions for these configurations:

G-Port Only ([Table 2-1](#))

G-Port and IGM ([Table 2-2](#))

The following notations apply to [Table 2-1](#) and [Table 2-2](#):

PT = Portability Type for the DN values:

0 – Not known to be ported

1 – Own number ported out

- 2 – Foreign number ported to foreign network
- 3 – Prepaid1, Prepaid Short Message Service Intercept (PPSMS) subscriber on server #1
- 4 – Prepaid2, PPSMS subscriber on server #2
- 5 – IS41 GSM migrated subscriber with only GSM handset active
- 6 – Prepaid3, PPSMS subscriber on server #3

through

35– Prepaid32, PPSMS subscriber on server #32

36 - Not identified to be ported

FF - No Status, None, No Portability Type

RN = Routing Number

SOR = Support for Optimal Routing

SRI = Send Routing Information

SP = Signaling Point

NE = Network Entity

Table 2-1 summarizes the actions taken based on the database result, and assumes that the IS41 GSM Migration feature is not turned on.

Table 2-1 G-Port Database Lookup

Message Type	MSISDN Found	Entity Result	MNPCRPN and HomeRN deleted from DN	Action
SRI	Yes	RN	No	SRI Ack using RN prefix. If Portability Type = 0, 1, 2, or 36 is present with MSISDN, NPS will be encoded. For Portability Type = 36, NPS will have a value of 0.
SRI	Yes	RN	Yes	Issue UIM 1256 and fall through to GTT
SRI	Yes	SP	N/A	Forward SRI message to the destination using SP data
SRI	Yes	None	No	Portability Type result is 0, 1, 2, 36, or no status. SRI Ack using MSISDN. Portability Type = 36 or no status will map to NPS=0 in response. Portability Type = 0, 1, or 2 will have the values of 0, 1, or 2.
SRI	Yes	None	No	Portability Type result is 3 - 35. Fall through and perform GTT
SRI	Yes	None	Yes	Portability Type result is 0, 1, 2, 36, or no status. Issue UIM 1256 and fall through to GTT

Table 2-1 (Cont.) G-Port Database Lookup

Message Type	MSISDN Found	Entity Result	MNPCRPN and HomeRN deleted from DN	Action
SRI	No	N/A	N/A	Fall through and perform GTT
Non-SRI or SRI-SOR	Yes	RN	No	Forward the message to the next node using RN data
Non-SRI or SRI-SOR	Yes	RN	Yes	Issue UIM 1256 and fall through to GTT
Non-SRI or SRI-SOR	Yes	SP	N/A	Forward the message to the next node using SP data
Non-SRI or SRI-SOR	Yes	None	No	Fall through and perform GTT
Non-SRI or SRI-SOR	Yes	None	Yes	Issue UIM 1256 and fall through to GTT
Non-SRI or SRI-SOR	No	N/A	N/A	Fall through and perform GTT

Table 2-2 IGM and G-Port Message Processing

NE/PT	SRI	SRI_SM	Other GSM
RN and PT = 0	MIGRPFX = single: ACK (use GSM2IS41 prefix) MIGRPFX = multiple: ACK (RN from EPAP)	SRI_SM_ACK with Return Error Component	Relay
RN and PT ≠ 0	ACK (RN from EPAP)	Relay	Relay
SP and PT = 5	Relay	Relay	Relay
SP and PT ≠ 5	Relay	Relay	Relay
No NE and PT = 5	GTT	GTT	GTT
No NE	ACK (no NE)	GTT	GTT
PT= 0, 1, 2, or No PT			
No DN entry found	GTT	GTT	GTT

Database lookup results in the following:

1. Fall through to GTT or
2. Relaying the message to the destination as noted in the database or
3. Returning an acknowledge message to the originating switch.

Message Relay describes how the EAGLE formulates a relayed message or a returned Ack.

Message Relay

The rules for formatting the SCCP CdPA GTA field are based on the value specified in the DigitAction field. If DigitAction = none, the EAGLE does not overwrite the SCCP

CdPA GTA. For all other values, the EAGLE formats the SCCP CdPA GTA according to the value assigned to DigitAction. Refer to [Table 2-3](#) for examples of DigitAction Expansion on the SCCP CdPA GTA of an outgoing message when the Entity ID = 1404 and the default country code = 886...

Table 2-3 DigitAction Applications

DigitAction	Value in Incoming CdPA GTA	Value in Outgoing CdPA GTA	Meaning
none	886944000213	886944000213	No change to the Called Party GTA (default)
prefix	886944000213	1404886944000213	Prefix Called Party GTA with the entity id
replace	886944000213	1404	Replace Called Party GTA with the entity id
insert	886944000213	8861404944000213	Insert entity id after country code. (CC + Entity Id + NDC + SN)
delccprefix	886944000213	1404944000213	Delete country code and add prefix (No action is taken if country code is not present.)
delcc	886944000213	944000213	Delete country code
spare1	886944000213	treated as none	No change to the Called Party GTA (default)
spare2	886944000213	treated as none	No change to the Called Party GTA (default)

Returning Acknowledgement

When an SRI Ack message is returned, the EAGLE follows the SRI Ack encoding rules along with these enhancements for added flexibility:

1. Allow users to specify which SRI parameter (the **TCAP** MSRN parameter) encodes the RN (and/or DN) information.
2. Allow users to specify the value to encode the Nature of Address field of the TCAP MSRN parameter.
3. Allow users to specify the value to encode the Numbering Plan field of the TCAP MSRN parameter.

MSRN Encoding

Refer to *Commands User's Guide* for detailed descriptions of the `chg-gsmopts` command, parameters, and parameter values.

The MSRN is encoded based on the MSRNDIG, MSRNNAI and DN NAI values.

If MSRNDIG and MSRNNAI are not provisioned in the GSMOPTS table, these default values are used:

- MSRNDIG = RN
- MSRNNAI = National Significant (0x02)

- MSRNNP = ISDN (0x01)

MSRN NAI that is not International (0x01) or Subscriber (0x04) is treated as National Significant (0x02) for the digit encoding format. The NAI field will be encoded with the original GSMOPTS value.

DN and DN NAI are determined by the SRIDN setting.

- If SRIDN = SCCP, then the DN is from CdPA and DN NAI is the Service NAI for the message as specified in the Service Selector information.
- If SRIDN = TCAP, then the DN is the MSISDN and DN NAI is the MSISDN NAI from the MAP portion of the message.

DN NAI that is not International (0x01) or Subscriber (0x04) is treated as National Significant (0x02). DN digits used for encoding have the HomeRN prefix, ST, and filler digits deleted. The DN is carried by an incoming message. An RN, SP, ASD, or GRN is extracted from the RTDB. If the RN is not found during the RTDB lookup, then MSRN is encoded with MAP MSISDN information.

When searching for a CC match, the DEFCC list and MULTCC list are searched. The Best CC Match from the DEFCC list or MULTCC List is referred to as *MatchCC*. The Best CC Match is defined as the largest number of identical leading digits during a comparison of Country Code digits against an MSISDN. If a DEFCC list or MULTCC list contains 1, 12, and 124 and the MSISDN is 12345, then the Best CC Match is 12.

If DEFCC or DEFNDC is not provisioned, those fields are ignored during MSRN encoding. No insertion or deletion of the DEFCC or DEFNDC occurs

To keep the transmitted MSRN from being too large after RN addition, MSISDN National Leading Digit (NLD) Truncation is allowed. When provisioned, a selected number of leading digits are removed from the National portion of the MSISDN before encoding the MSRN.

Some MSRN generation rules are not applied because the rules represent scenarios that result in processing of the message in a way that does not require MSRN generation. For example, RTDB queries are performed based on DS values in International format. If G-Port encounters an MSISDN with a National NAI and the STPOPTS:DEFCC value is not defined, then the MSISDN cannot be converted to the International format as required for an RTDB query. The system does not generate an MSRN if an RTDB query cannot be performed first.

SRI Ack Message Encoding

[Table 2-4](#) summarizes the possible changes by G-Port to the TCAP/MAP fields.

Table 2-4 G-Port SRI Ack message: TCAP/MAP Portion

Field	Value
Invoke ID	copied from SRI Invoke Id
Sequence Tag	0x30 for MAP Phase 1 or Phase 2 0xA3 for MAP Phase 2+
Parameter Sequence Length	adjusted based on the parameters included in the response

Table 2-4 (Cont.) G-Port SRI Ack message: TCAP/MAP Portion

Field	Value
IMSI digits	RFIMSI digits obtained from SRF data associated with the RN - If SRFIMSI is not available, then the GSMOPTS table will be searched for an MCCMNC match to the CCNC from DN. If an MCCMNC match is not available, DEFMCC is padded to 5 digits and used. If DEFMCC is not provisioned, a length of 0 is used.
CUG-CheckInfo	copied from the SRI message
MSRN NAI	obtained from MSRNNAI in GSMOPTS table or National
MSRN Numbering Plan	obtained from MSRNNP in GSMOPTS table or E.164
MSRN digits	Refer to MSRN Encoding .
MSISDN (optional)	copied from SRI MSISDN parameter sequence based on whether non-concatenated MSRN is selected with MSRNDIG option in the GSMOPTS table
NumberPortabilityStatus (optional)	<p>Number Portability Status parameter will be included in the SRI Ack message only if:</p> <ul style="list-style-type: none"> • MAP phase is 2+. • The ENCODENPS option in the GMSOPTS table is set to on and the DN is found in the RTDB with Portability Type (PT) = 0, 1, 2, or 36. • The ENCDNPSPTNONE option in the GMSOPTS table is set to on and the DN is found in the RTDB with PT = 255. • The ENCDNPSDNNOTFOUND option in the GMSOPTS table is set to on and the DN is not found in the RTDB. <p>SRI Ack message is sent by G-Port SRI Query for Prepaid feature if the DN is not found in the RTDB.</p>

Determination of MAP Phase

The phase or version of the MAP protocol is determined from the ACN.

If ACN received is found to be from SRI (in the form: map-ac-locInfo retrieval(s) version xx, such as '04000010005xx'), the last byte ('xx') of the ACN determines the version/phase of the MAP, as shown in [Table 2-5](#). If the ACN does not match the one defined in ETSIGSM 03.18, the MAP version/phase is assumed to be from the `defmapvrr` parameter of GSMOPTS specification.

Table 2-5 MAP Phase Determination

Last Byte in ACN	MAP Phase
00	Specified by <code>defmapvrx</code> parameter of a GSMOPTS command
01	Phase 1
02	Phase 2
03	Phase 2+
Greater than 3	Specified by <code>defmapvrx</code> parameter of a GSMOPTS command

G-Port Message Handling

G-Port performs message handling in the following steps.

1. The message arrives at the EAGLE *route-on-gt*. The EAGLE decodes the SCCP portion and uses the data to perform the G-Port selection based on the CdPA GT fields other than the ES and GTAI. The result of the selection provides a service indicator. The service indicator is G-Port if it is determined that MNP-SRF is required. If a G-Port selector does not match the incoming GT fields, the message is passed on for GTT selection.
2. If step #1 indicates that MNP SRF is required and the message is not a UDTS generated by the EAGLE, then the EAGLE performs SSN-based discrimination. If the message is a UDTS generated by the EAGLE, then regular GTT is performed on the message.
3. MNP-SRF first decodes the Operation Code of the MAP message to distinguish the SRI or SRI_SM message from the rest. If the Operation Code is SRI, the OR Interrogation indicator is absent, and the GSMOPTS parameter SRIDN=TCAP, then the MSISDN parameter is decoded from the MAP portion of the message. If the Operation Code is SRI_SM and the GSMSMSOPTS parameter SRISMDN=TCAP, then the MSISDN parameter is decoded from the MAP portion of the message. If the value is SCCP for GSMOPTS parameter SRIDN (if an SRI message) or for GSMSMSOPTS parameter SRISMDN (if an SRI_SM message), or if the message is not SRI or SRI_SM, then, the digits available in the SCCP CdPA GTAI are used for database lookup.
4. The decoded DN from either the MAP MSISDN or SCCP CdPA is conditioned to an international number before performing the database lookup. The conditioning which is performed depends on whether the digits are obtained from SCCP or TCAP part of the message.
 - If the digits are from the SCCP part, the number conditioning is based on SNAI value. The RN prefix deletion is performed, followed by conversion to an international number based on its value. Conversion to international format is based on DEFCC and DEFNDC, as required. If the incoming number is CCRNDN, DEFCC and MULTCC are used to determine the Best Match CC to locate the RN digits for RN prefix deletion
 - If the digits are from the MAP part, the number conditioning is based on NAI of MSISDN parameter. Prefix deletion is performed if MNPCR is on. The number is converted to an international number, if necessary. Conversion to international format is based on DEFCC and DEFNDC, as required. If the incoming number is international, DEFCC and MULTCC are used to determine

if the format is CCRNDN or RNIDN. If a Best Match CC is located, then it is used to locate the RN digits for RN prefix deletion.

5. The database lookup is performed in two steps:
 - The exception or individual number database is searched for a match. If the match is found, the data associated with this entry is considered.
 - If the conditioned number is absent in the exception database, the number range database is searched. If the match is found, the data associated with this range entry is considered. If the search is unsuccessful, the result is no match.
6. If the number is found and an RN prefix is present for this entry, then:
 - *for SRI message*: If **MNPCR**P is off or if MNPCR is on with CRP on Translation Type off and a HomeRN was not present in the incoming DN (a HomeRN was not deleted from the SCCP CdPA/MAP MSISDN), then G-Port generates an SRI Ack message with the RN prefix in the Routing Number parameter.
 - If SRI_SM GTT Routing is on, then SRI_SM messages are not relayed. The CdPA GTA in the message is modified in CC + RN + DN format, or RN + IDN format if a CC match is not found in the leading digits. The NAI of CdPA GTA is set to International and the SRI_SM message falls through to GTT.
 - *for non-SRI message*: If MNPCR is off or if MNPCR is on and a HomeRN was not present in the incoming DN (a HomeRN was not deleted from the SCCP CdPA), then G-Port uses the translation data for the number to alter the CdPA digits and route the message to the destination.
 - *for SRI or non-SRI message*: If MNPCR is on and a HomeRN was present in the incoming DN (a HomeRN was deleted from the SCCP CdPA/MAP MSISDN), then G-Port generates UIM #1256 and the message falls through to GTT. In most network implementations the message contains RN+DN which will cause a GTT failure. This GTT failure results in the EAGLE sending a UDTs to the originator if the Return Message on Error flag was set in the incoming UDT.
7. If the number is found and an SP entity is present for this entry, G-Port uses the SP translation data as the number to route the message to the destination. This is true whether or not the MNPCR feature is on. However, the SRI_SM message is not relayed if SRI_SM GTT Routing on, the **GRN** is associated along with the SP entity with the DN, and the GRN is not present in the HomeRN table. In this case, the CdPA GTA of the SRI_SM is modified in CC + GRN + DN format, or GRN + IDN format if a CC match is not found in the leading digits. The NAI of CdPA GTA is set to International and the SRI_SM message falls through to GTT.
8. If the number is found and neither SP nor RN data is associated with it (direct routing case with number not known to be ported or not identified to be ported), these occur:
 - *for SRI message*: If MNPCR is off, or if MNPCR is on and no HomeRN is present in the incoming DN (a HomeRN was not deleted from the SCCP CdPA/MAP MSISDN), and the portability type associated with the DN entry is other than 3 through 35, then G-Port generates an SRI Ack message with the MSISDN in the Routing Number parameter. If MNPCR is off, or if MNPCR is on and no HomeRN was present in the incoming DN (a HomeRN was not deleted from the SCCP CdPA/MAP MSISDN), and the portability type

associated with the DN entry has a value of 3 through 35, then the SRI falls through to GTT and no SRI Ack message is generated.

- *for non-SRI message*: If MNPCR is off, or if MNPCR is on and no HomeRN is present in the incoming DN (a HomeRN was not deleted from the SCCP CdPA), then the message falls through to GTT.
 - *for SRI or non-SRI message*: If MNPCR is on and a HomeRN was present in the incoming DN (a HomeRN was deleted from the SCCPCdPA/MAP MSISDN), then G-Port generates UIM #1256, and the message falls through to GTT. In most network implementations, the message contains RN+DN which will cause a GTT failure. This GTT failure results in the EAGLE sending a UDTs to the originator if the Return Message on Error flag was set in the incoming UDT.
 - The Number Portability Status Indicator (NPSI) is encoded in the SRI Ack message if either (1) GSMOPTS:ENCODENPS=ON and the DN is associated with PT = 0, 1, 2, 36 or (2) GSMOPTS:ENCDNPSPTNONE=ON and the DN is associated with PT = no status
9. If the number is not found in the database, then the GSMOPTS:SRIDNNOTFOUND option is consulted if the query is not G-Port SRI Query for Prepaid. If the query is identified as G-Port SRI Query for Prepaid, then an SRI Ack message is returned. The Number Portability Status Indicator (NPSI) is encoded in the SRI Ack message if GSMOPTS:ENCDNPSDNNOTFOUND=ON.
 10. If the GSMOPTS:SRIDNNOTFOUND option is set to SRINACK, then a negative acknowledgement is generated in response to the message.
 11. If the GSMOPTS:SRIDNNOTFOUND option is set to GTT, then GTT is performed on the message.

2.2.2 G-Port Call Flows

This section contains several illustrative sample call flows: G-Port supports all call flows identified in GSM 03.66 other than noted exceptions. This section contains a mix of call flows using both indirect and direct routing.

These call flows, including calls to imported or non-ported numbers, show one possible scenario regarding how messages are routed in the network and where various stages of GTT are performed. G-Port may perform intermediate or final GTT depending on the message received and provisioned data.

Several call flows refer to non-call related messages. Examples of non-call related messages are **SRI** for Short Message Service and SRI for Optimal Routing.

In all G-Port call flows, the MSISDN used for the database search is converted to an international number, if necessary, prior to the database search.

Mobile Terminated Call to Non-Ported or Imported Number (Indirect Routing)

The first call flow example is for a mobile terminated call to a non-ported or imported number by indirect routing. Refer to [Figure 2-1](#).

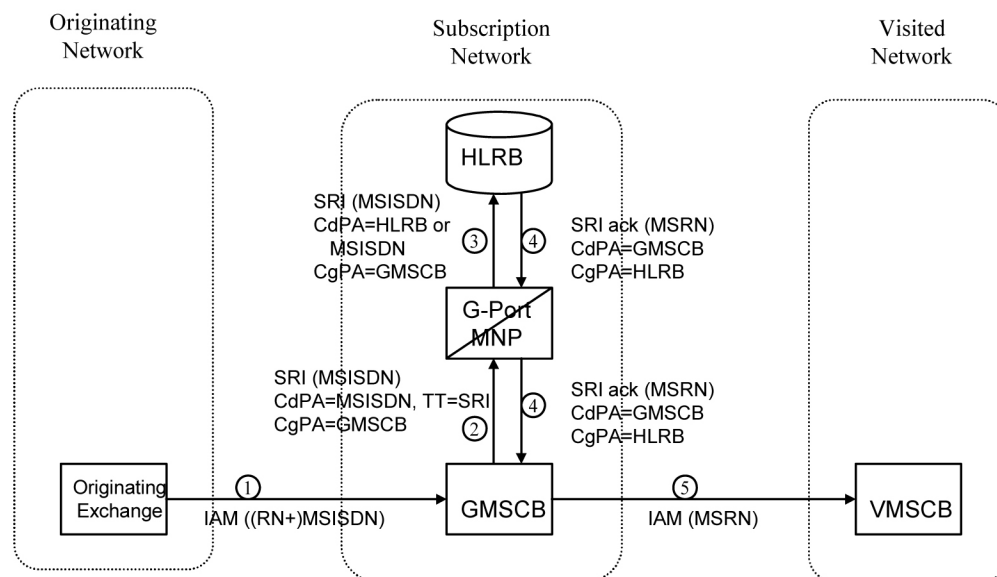
Figure 2-1 Mobile Terminated Call by Indirect Routing

1. The originating exchange sends an **IAM** message to **GMSCB** in the subscription network. When the number is imported, the original number range owner network has already performed a database lookup and determined the new subscription network (Routing Number). As shown in the figure, this could be sent in the IAM along with the MSISDN.
2. GMSCB sends an SRI request to the MNP-SRF. This request may or may not contain the new TT = SRI. Global title information triggers G-Port processing. The MNP-SRF determines the message is an SRI and uses the **MSISDN** from the MAP message to search the database. A match is found with no Routing Number and an HLR **GT** address for **HLRB**, or no match is found and falls through to GTT, producing a routing to HLRB. Alternatively and not illustrated in the figure, GTT could route to another node, possibly in a different network.
3. The message is routed to HLRB.
4. HLRB responds to GMSCB with an SRI ack. This message can be GT routed through the STP or MTP routed.
5. GMSCB sends an IAM with the roaming number to the visited network.

Mobile Originated/Terminated Call to an Exported Number (Direct Routing)

This call flow example is for a call that is mobile originated or terminated to an exported number by direct routing. Refer to [Figure 2-2](#).

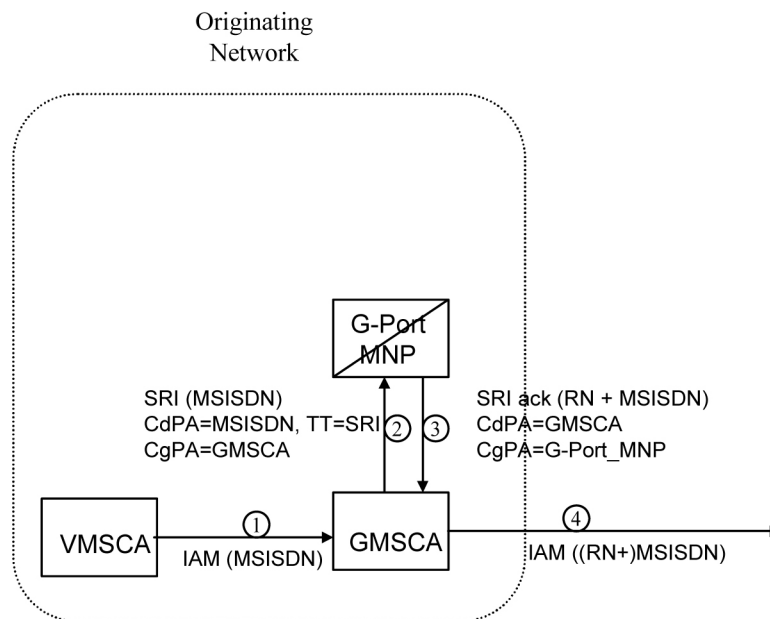
Figure 2-2 Call to an Exported Number by Direct Routing

This call flow assumes the originating network is not the subscription network. If indirect routing were used in this example, the originating network would first route the call to the number range owner network, according to pre-portability rules, where the MNP-SRF and NPDB are accessed to locate the Routing Number.

1. When the call is originated, **VMSCA** sends an IAM message to **GMSCA**.
2. GMSCA sends an SRI request to the MNP-SRF. This may or may not contain the new TT = SRI. Global title information triggers G-Port processing. The MNP-SRF determines the message is an SRI and uses the MSISDN from the MAP message to search the database. A match is found with the Routing Number field populated.
3. The MNP-SRF responds to GMSCA with an SRI ack containing the Routing Number prefixed to the MSISDN number as the Roaming Number.
4. GMSCA sends an IAM with the roaming number to the subscription network. The Routing Number is used by GMSCA and possibly by transit exchanges to route the call to the subscription network.

MO/MT Call to a Number Not Known to be Ported (Direct Routing)

This call flow example is for a call that is mobile originated (**MO**) or mobile terminated (**MT**) to a foreign number that is not known to be ported by direct routing. Refer to [Figure 2-3](#).

Figure 2-3 MO/MT Call to Number Not Known to be Ported (Direct Routing)

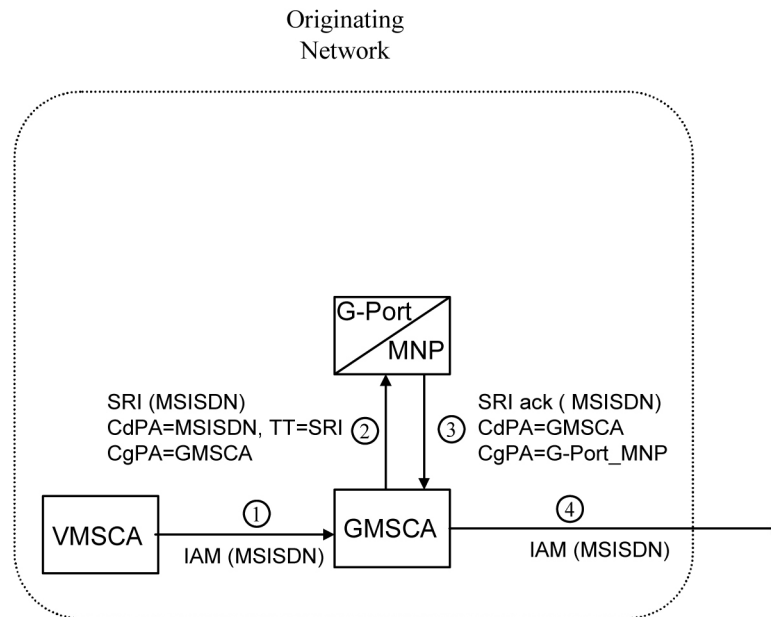

This call flow assumes the originating network is not the subscription network.

1. When the call is originated, **VMSCA** sends an IAM message to **GMSCA**.
2. GMSCA sends an SRI request to the MNP-SRF. This request may or may not contain the new TT = SRI. Global title information triggers G-Port processing. The MNP-SRF determines the message is an SRI and uses the MSISDN from the MAP message to search the database. A match is found, but the Routing Number and HLR Address fields are not populated.
3. The MNP-SRF responds to GMSCA with an SRI ack containing the MSISDN number.
4. GMSCA sends an IAM with the roaming number to the subscription network.

Non-Call Related Message for Non-Ported Number (Indirect Routing)

This call flow example is for a non-call related message for a non-ported number by indirect routing. Refer to [Figure 2-4](#).

Figure 2-4 Non-Call Related Message for Non-Ported Number

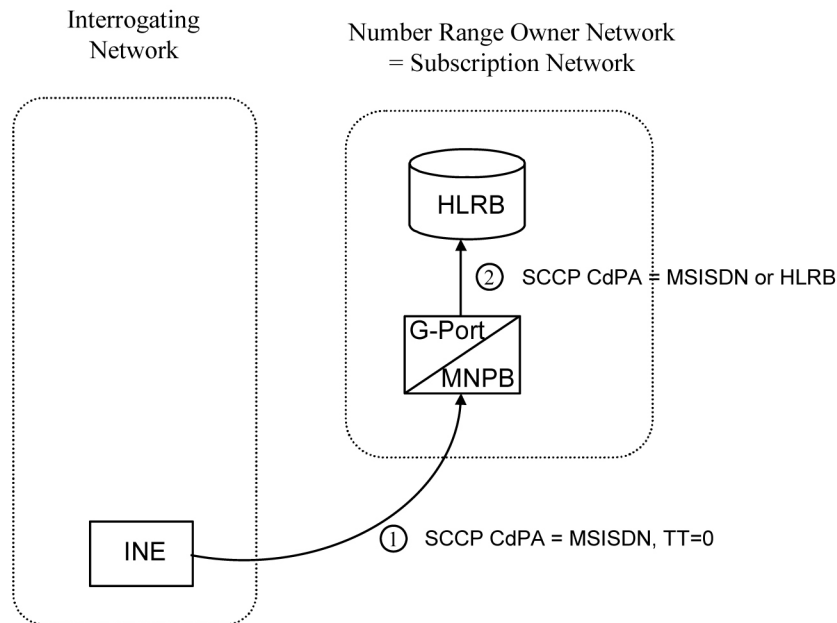

1. The Interrogating Network Entity (**INE**) sends the non-call related message to **MNP-SRFB** in the number range owner network. The SCCP CdPA contains the MSISDN number of the subscriber and the TT. The TT may be either 0 as shown in the figure, or another value depending upon the service, such as TT=17 for CCBS service.
2. Global title information triggers G-Port processing. MNP-SRFB determines the message is non-call related (i.e. not an SRI that doesn't require Optimal Routing) and uses the MSISDN from the SCCP CdPA to search the database. No match is found, so MNP-SRFB uses GTT to locate the GT address associated with the MSISDN to route the message to HLRB.

Non-Call Related Message for Ported Number (Indirect Routing)

This call flow example is for a non-call related message for a ported number by indirect routing. Refer to [Figure 2-5](#).

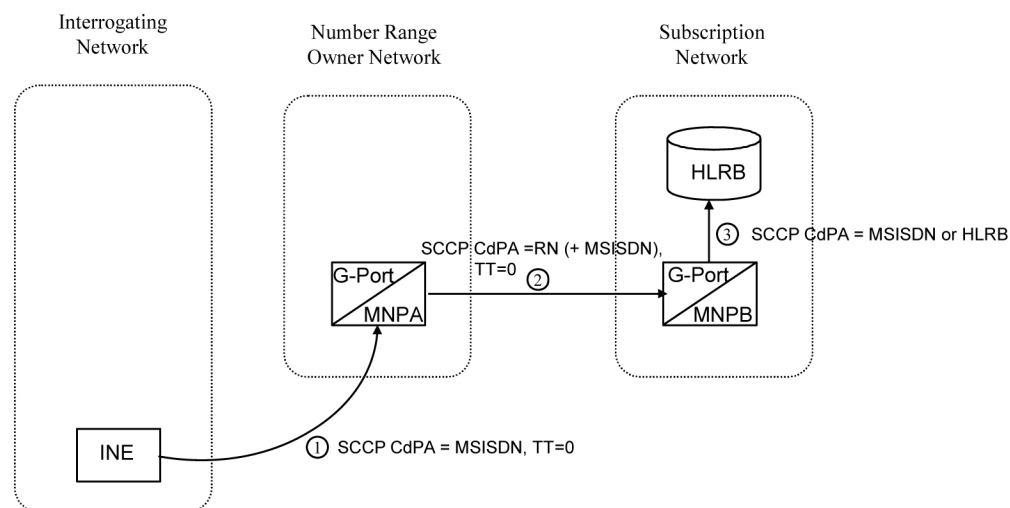
Figure 2-5 Non-Call Related Message for Ported Number

1. The Interrogating Network Entity (INE) sends a non-call related message to MNP-SRFA in the number range owner network. The SCCPCdPA contains the MSISDN number of the subscriber and the TT. The TT may be either 0 as shown in the figure, or another value depending upon the service, such as TT=17 for CCBS service.
2. Global title information triggers G-Port processing. MNP-SRFA determines the message is one requiring message relay (that is, not an SRI that doesn't require Optimal Routing) and uses the MSISDN from the SCCPCdPA to search the database. A match is found, and MNP-SRFA uses the Message Relay GT address associated with the match to route the message to the subscription network.
3. MNP-SRFB receives the message and determines the message is one requiring message relay (that is, not an SRI that does not require Optimal Routing). It checks if the SCCPCdPA begins with a Prefixed RN. If it does, it removes the prefix. In either case, it uses the MSISDN from the SCCPCdPA to search the database. A match is found, and MNP-SRFB uses the HLRGT address associated with the match to route the message to HLRB.

Non-Call Related Message for Ported or Non-Ported Number (Direct Routing)

This call flow example is for a non-call related message for either a ported or non-ported number by direct routing. Refer to [Figure 2-6](#).

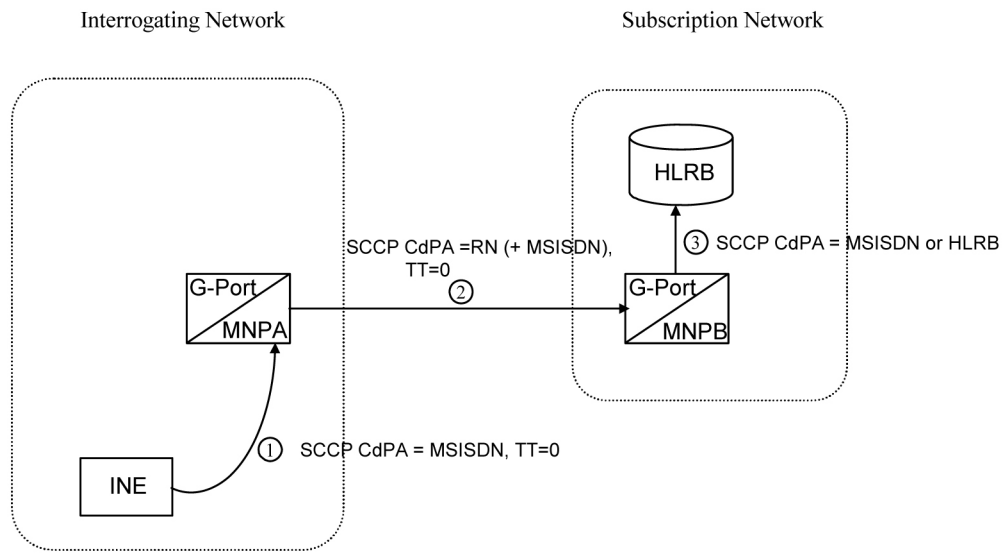
Figure 2-6 Non-Call Related Message for Any Number

This call flow assumes the originating network is not the subscription network.

1. The Interrogating Network Entity (INE) sends the non-call related message to MNP-SRFA in the interrogating network. The SCCP CdPA contains the MSISDN number of the subscriber and the TT. The TT may be either 0 as shown in the figure, or another value depending upon the service, such as TT=17 for CCBS service.
2. Global title information triggers G-Port processing. MNP-SRFA determines the message is one requiring message relay (that is, not an SRI that doesn't require Optimal Routing) and uses the MSISDN from the SCCP CdPA to search the database.
 - If a match is found (ported case), MNP-SRFA uses the Message Relay GT address associated with the match to route the message to the subscription network.
 - If a match is not found (non-ported case), MNP-SRFA uses GTT to route the message to MNP-SRFB.
3. MNP-SRFB receives the message and determines the message requires message relay (that is, not an SRI that does not require Optimal Routing). It checks to see if the SCCP CdPA begins with a Prefixed RN. If so, it removes the prefix. In either case, it uses the MSISDN from the SCCP CdPA to search the database.
 - If a match is found (imported case), MNP-SRFB uses the HLR GT address associated with the match to route the message to HLRB.
 - If a match is not found, MNP-SRFB uses GTT to route the message to HLRB.

2.3 Network Perspectives

GSM Mobile Number Portability (G-Port) provides the capability for a mobile subscriber to change the GSM subscription network within a portability cluster while

retaining the original MSISDNs. Because the **IMSI** is not ported, the recipient network of the porting process issues a new IMSI for the ported subscriber.

In a Public Land Mobile Network (**PLMN**) that supports G-Port, SCCP messages that are sent to an HLR can be relayed by either:

- An **MNP-SRF**
- An **EAGLE** with G-Port depending on the type of message (call-related or non-call-related) and on the porting status of the called subscriber.

For call-related messages, **MNP-SRF** either generates an **SRI_ACK** response with the routing number if the number is ported, or relays the message to an appropriate HLR if the number is not ported.

For non-call related messages, **MNP-SRF** can modify the SCCP called party address and route the message to the HLR of the recipient network or to the subscription network.

Figure 2-7 shows the location of the G-Port in a GSM network. Note the basic functions G-Port performs:

- G-Port performs a query/response for call-related SRI messages when the number is ported-out, not known to be ported, or not identified to be ported.
- G-Port performs a message relay function for non-call-related messages and for call-related messages when the number is non-porting or porting-in.

G-Port performs the following actions based on the message received and number status:

- If the message received is call-related SRI (not-**SOR**) and the number is porting-out, not known to be porting, or not identified to be porting, G-Port sends the SRI ack to the MSC with the Routing Number information in the MAP portion of the message.
- If the number is porting-out and the message received is non-call related (non-SRI), G-Port performs a message relay function and forwards the translated message based on the Routing Number information.
- If the number is non-porting or porting-in, G-Port performs an HLR translation and forwards the translated message to the HLR.

An additional user option allows configuration of G-Port to modify the above processing as follows:

- If the number is not found in the RTDB (individual or range), then G-Port returns a negative acknowledgement in response to an SRI.

Figure 2-7 G-Port Node in GSM Network

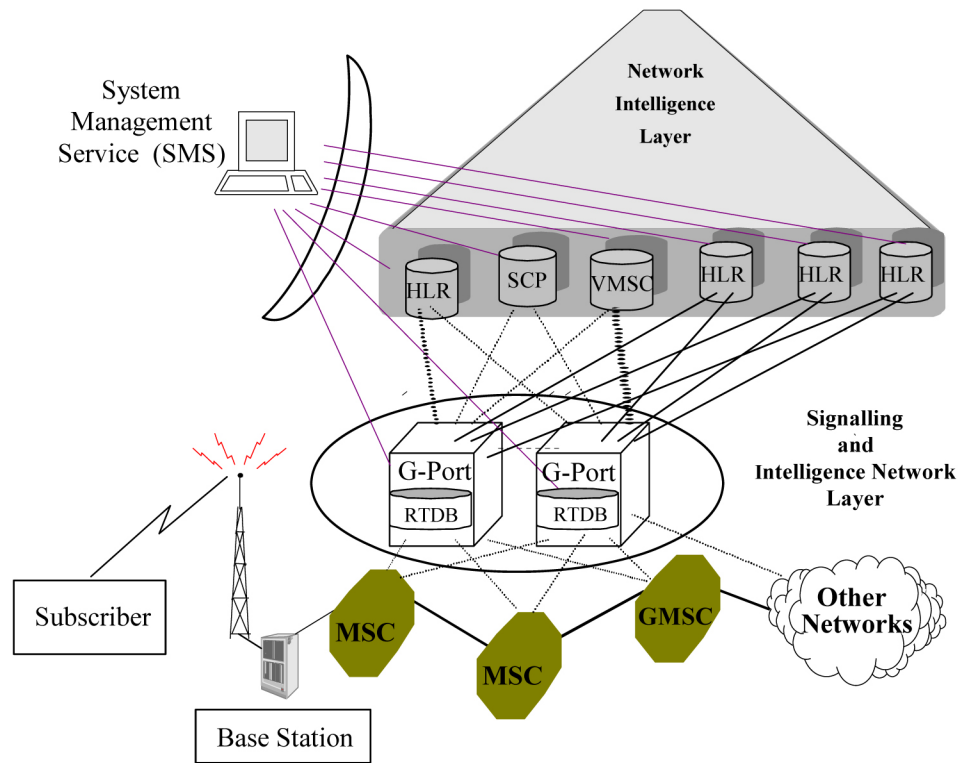

2.4 G-Port Considerations

The following items must be considered before installing and operating the G-Port feature.

1. SRI responses are routed by both MTP and Global Title Translation.
2. The maximum length of the Application Context Name Object Identifier is 32 digits.
3. For G-Port Message Relay messages with E.164 numbers in the SCCP CdPA, it is assumed that no truncation occurred if and when the routing number was prepended and that SCCP CdPA has the full DN of the subscriber.
4. G-Port Message Relay to the EAGLE local subsystem is not supported.
5. Only the first 21 digits of the CdPA are decoded for G-Port Message Relay. For example, if the CdPA contains an RN prefixed to a DN, the RN is seven digits, and the DN is 15 digits, then the total is 22 digits, and the DN used for processing will be only 14 digits (21 total digits less 7 RN digits).
6. With the Hex Digit Support for GTT feature enabled and turned on, Message Signaling Units (MSUs) containing either decimal or hexadecimal digits in the Called Party Address (CdPA) are processed. Unless the Hex Digit Support for GTT feature is enabled and turned on, **GTT** processes decimal digits only.

If the Hex Digit Support for GTT feature is not enabled and not turned on and an operator or country is using hexadecimal digits A through F in RNs and the operator is providing GTT to messages that have RN prefixes other than its own prefixes, then the operator must enter the RN + DN number ranges as DN ranges

in the RTDB. The beginning and ending DNs can be only 15 digits, which may not be sufficient for an RN + DN.

7. In this document, Mobile Number Portability (MNP) applies within a single portability cluster. This is defined as a set of networks in a country or multi-country region having a common numbering plan and across which a subscriber already inside the cluster can port. Any individual G-Port node is required to support only an MNP within such a portability cluster.
8. The EAGLE examines the TCAP portion of the MAP message to determine the message type. Although **GSM** 03.66 defines a new translation type for SRI-MNP messages, G-Port does not rely upon the use of this TT.
9. The routing number found in the database is either prefixed to the dialed number to form a new concatenated roaming number that is returned to the switch, or is sent on its own as the roaming number.
10. No MAP overload procedures, as defined in GSM 09.02, need to be supported by G-Port.
11. All non-call related messages affected by MNP contain the MSISDN number in the SCCP CdPA. In the case of the SRI message, G-Port may get the number from the MAP level.
12. TCAP operation codes uniquely distinguish MAP SRI messages and do not change from one phase (or version) of MAP to another.
13. PCs or PC + SSNs that are in the entity table of the database and referenced by subscriber entries do not necessarily have the required data present on the EAGLE to route messages to them. For example, the point code may not have a route or the PC + SSN may not be in the MAP table for a final GTT. In this event, a UIM is output only when a message is discarded because of the lack of data.
14. The parameters of the SRI Ack message generated by G-Port are based solely on the provisioned data or options; they are not based on the MAP phase of the SRI message. For example, if the message received is phase 1 or 2, MSRNDIG=RN, and the portability status is "NotKnownToBePorted", G-Port generates an SRI Ack message containing IMSI, MSRN, MSISDN, and NPS parameters, despite the MSISDN and NPS parameters not being defined for phase 1 or 2.
15. If SRFIMSI is not provisioned with an RN entity and an incoming message is an SRI message, G-Port sets IMSI parameter as one of these options:
 - a. If a CCNDC>MCCMNC match in GSMOPTS is found, then the MCCMNC is encoded.
 - b. If DefMCC is provisioned in GSMOPTS, then DefMCC is encoded.
 - c. Zero digits are encoded.
16. G-Port uses the MTP route for the SRI Ack message, even when the final GTT is performed on the response.
17. When the concatenated number (RN + MSISDN) option is selected for encoding the Routing Info (MSRN) in the SRI Ack message, G-Port encodes the complete concatenated number because the concatenated number length may otherwise exceed 16 digits, which is the maximum allowed in MSRN.
18. Routing an SRI Ack message to a network domain different from the network domain from which query was received is not supported by G-Port. Routing failures or unexpected routing of SRI Ack messages may result.

19. Post G-port, EAGLE routes the Eagle generated SRI_ACK message only to the translated point code as result of fall back to GTT. It does not check the MRNSET or MAPSET mapped to the GT translation. It will not check even the DEFAULT MRNSET or MAPSET.

2.5 General Numbering Requirements

Incoming called party numbers, from the SCCP portion, destined for IGM processing are conditioned to fit the GDB requirements where possible. The following factors are used to condition the SCCP numbers.

- Based on provisioning: If the GTT selectors available in the incoming message match an entry in the IGM selector table, then the service numbering plan from the selector table entry uses that number's numbering plan. Further conditioning is applied based on this new numbering plan.
- Based on configurable options: If the GTT selectors available in the incoming message match an entry in the IGM selector table, then the service nature of address from the selector table entry uses that number's nature of address. Further conditioning is applied based on this new nature of address.
- If the nature of address is Subscriber, the default CC + default NC (network code for E.164) are prepended to the number. The default codes to be used by the EAGLE must be previously provisioned by the EAGLE operator. If not, a UIM is issued, and the message falls through to GTT.

Numbers with fewer than five digits after the above conditioning are not used for **IGM**. In this case, a UIM is issued, and the message falls through to GTT.

Numbers with more than fifteen digits after the above conditioning are not used for **IGM**. In this case, a UIM is issued, and the message falls through to GTT.

2.6 G-Port SCCP Service Re-Route Capability

This feature is designed to handle and control re-routing of **G-Port** traffic from an affected node to alternate nodes within an operators network. This feature is an optional feature and doesn't affect the normal **G-Port** functionality. This feature consists to the following main functions:

- [Service State](#)
- [MNP Re-Routing](#)
- [MNP Capability Point Codes](#)

G-Port SCCP Service Re-Route Capability is not supported for the Prepaid **SMS** Intercept feature. **G-Port SCCP Service Re-Route** Capability is supported for the **IS-41** to **GSM** Migration feature.

Service State

Service state is part of the **G-Port SCCP Service Re-Route** Capability. Service state is used to indicate the current state of **G-Port**, either **ONLINE** or **OFFLINE**. Service state also gives the user the option to mark **G-Port** as **OFFLINE** or **ONLINE** based on the current behavior. If a **G-Port** problem is identified, **G-Port** can be marked **OFFLINE** to initiate the re-routing procedure. This feature also provides the option to mark **G-Port OFFLINE** to perform a controlled re-routing during this state.

MNP Re-Routing

MNP Re-Routing is an optional feature and is enabled by defining a list of alternate **PCs** or by defining the **GTT** option. **G-Port** re-routing is activated by marking **G-Port OFFLINE**. When **G-Port** is **OFFLINE** and alternate **PCs** are provisioned, any messages destined for **G-Port** are re-routed to the available alternate **PCs** that are defined for **G-Port**. If alternate **PCs** are not provisioned or none are available, then the **GTT** option is used. If the **GTT** option is set to **YES**, then messages destined for **G-Port** will fall through to **GTT** as part of the re-routing procedure.

Re-Routing is applied to all **G-Port** messages (based on **SRVSEL**). There is no distinction of **DPC** of the messages. The **DPC** of the message can be either True, Secondary, or Capability Point code.

MNP Capability Point Codes

Capability Point Codes (**CPC**) are also supported for **G-Port**. The use of MNP capability point code aids the adjacent nodes in knowing about **G-Port** outages. When **G-Port** is brought down through administrative commands, all traffic destined to this **G-Port** node will generate a Transfer Prohibited (**TFP**) message to the adjacent node about the **G-Port CPC**. The **TFP** response to the adjacent node causes the traffic originating nodes to stop sending **G-Port** traffic to this node. All **G-Port** traffic coming into this node is sent to the alternate **G-Port** nodes. Adjacent nodes will initiate route-set-test procedures after receipt of the **TFP** response.

If the messages are destined to the **EAGLE** true point code, then **TFP** messages are not generated when the **G-Port** service is **OFFLINE**. The originator would not be aware of the outage.

Once **G-Port** is back in service on the **EAGLE**, a Transfer Allowed (**TFA**) message is sent to the traffic adjacent nodes in response to route-set-test message. The traffic originating nodes will then start sending **G-Port** traffic to the original **G-Port** node.

MNP Capability point codes can be provisioned when the **G-Port** feature is on. There can be more than one **Capability Point Code** assigned to **G-Port CPC Type**.

When the G-Port feature is turned on and the G-Port service state is set to offline, the user can change the service to online at any point. After the feature is turned online, G-Port starts processing messages if at least one Service Module card is IS-NR.

The G-Port service can be set to **OFFLINE** at any point. This causes the **EAGLE** to stop processing G-Port traffic and re-routing is performed.

The G-Port service state is persistent. Booting the OAM or all the Service Module cards will not change the service state. Commands must be used to change the service state.

G-Port supports up to seven alternate PCs per domain. All six domains (ANSI, ITU-I, ITU-I Spare, ITU-N, ITU-N Spare, and ITU-N24) are supported. An entire set of alternate PCs is considered as a re-route set. A **GTT** option is supported for G-Port re-route. When the G-Port service is **OFFLINE**, G-Port messages fall through to **GTT** based on the **GTT** option. This option is set to **YES** by default.

G-Port SCCP Service Re-Route Capability Summary

If the **G-Port** service is not normal (because the **RTDB** is not in sync with **MPS** or if cards are misrouting **G-Port** messages) then the **G-Port** service state should be changed to **OFFLINE**.

Before changing **G-Port** service to **OFFLINE** , it should be decided what kind of re-routing will be used during the outage. The **EAGLE** supports re-routing data to alternate point codes or falling through to **GTT** as two possible options. Rerouting to alternate point code has priority over falling through to **GTT**. Examples of the two options follow:

Option 1

Define alternate point codes to re-route **G-Port** traffic. This is the recommended option. Up to 7 alternate **G-Port** nodes can be provisioned to re-route all the incoming **G-Port** traffic. Once provisioned, the **G-Port** service can be changed to **OFFLINE** . This example has any incoming being **G-Port** traffic being load-shared to point codes based on the relative cost.

```
chg-sccp-serv:serv=gport:pci1=1-1-1:rc1=10:pci2=2-2-2:rc2=10:pci3=3-3-3:rc3=10:pci4=4-4-4:rc4=10
```

```
chg-sccp-serv:serv=gport:pci1=5-5-5:rc1=10:pci2=6-6-6:rc2=10:pci3=7-7-7:rc3=10:pci4=8-8-8:rc4=10
```

```
chg-sccp-serv:serv=gport:state=offline
```

Option 2

With this option default **GTT** translations are provisioned for **G-Port** service. Then the `chg-sccp-serv` command is used to provision **GTT=YES**. All **G-Port** messages will fall through to **GTT**. An example command follows:

```
chg-sccp-serv:serv=gport:gtt=yes (it is yes by default)
```

Once the **G-Port** re-routing data is provisioned, **G-Port** service can be changed to **OFFLINE** . At this point all **G-Port** traffic will be re-routed. The user can take necessary steps to correct the **G-Port** service on the node. Until all the cards or enough cards are in active state with valid **G-Port** database, **G-Port** service should not be changed to **ONLINE** .

[Table 2-6](#) shows the actions taken when the **G-Port** service is offline, a message arrives at the affected node requiring **G-Port** service, and Service Module cards are available.

Table 2-6 G-Port SCCP Service Re-Route Capability Summary

Result of service selector	DPC	Alternate point code defined and available	GTT to be performed as fall through	Message Handling	Network Management
G-Port	G-Port Capability PC	Yes	N/A	Re-Route to alternate point code based on relative cost	TFP concerning CPC
G-Port	G-Port Capability PC	No*	Yes	Fall through to GTT and perform GTT	TFP concerning CPC
G-Port	G-Port Capability PC	No*	No	Generate UDTS (return cause = network failure)	TFP concerning CPC

Table 2-6 (Cont.) G-Port SCCP Service Re-Route Capability Summary

Result of service selector	DPC	Alternate point code defined and available	GTT to be performed as fall through	Message Handling	Network Management
G-Port	G-Port Capability PC	Not Defined	Yes	Fall through to GTT and perform GTT	TFP concerning CPC
G-Port	G-Port Capability PC	Not Defined	No	Generate UDTS (return cause = no relation for this addr)	TFP concerning CPC
Not G-Port	G-Port Capability PC	N/A	N/A	Perform appropriate Service/ GTT	None
G-Port	True or Secondary PC or non- G-Port CPC	Yes	N/A	Re-Route to alternate point code based on relative cost	None
G-Port	True or Secondary PC or non- G-Port CPC	No*	No	Generate UDTS (return cause = network failure)	None
G-Port	True or Secondary PC or non- G-Port CPC	No*	Yes	Fall through to GTT and perform GTT	None
G-Port	True or Secondary PC or non- G-Port CPC	Not Defined	Yes	Fall through to GTT and perform GTT	None
G-Port	True or Secondary PC or non- G-Port CPC	Not Defined	No	Generate UDTS (return cause = no relation for this addr)	None
Not G-Port	True or Secondary PC or non- G-Port CPC	N/A	N/A	Perform appropriate Service/ GTT	None

* Alternate point codes are defined and unavailable (prohibited or congested).

Table 2-7 shows the actions of LIM re-route functionality when Service Module cards are unavailable or down.

Table 2-7 G-Port LIM Re-Route Message Handling Summary

Routing Indicator in Incoming Message	DPC	Full or Partial Failure	G-Port Service Status	Message Handling	Network Management
rt-on-gt	G-Port Capability PC	Full	N/A	Generate UDTS	TFP concerning CPC, UPU
rt-on-gt	Non G-Port Capability PC	Full	N/A	Generate UDTS	TFP concerning CPC, UPU
rt-on-gt	True PC	Full	N/A	Generate UDTS	UPU
rt-on-gt	G-Port Capability PC	Partial*	ONLINE	Generate UDTS	None
rt-on-gt	True PC or non G-Port Capability PC	Partial*	ONLINE	Generate UDTS	None
rt-on-gt	G-Port CPC	Partial*	OFFLINE	Generate UDTS	TFP concerning CPC, UPU
rt-on-gt	True PC or non- G-Port CPC	Partial*	OFFLINE	Generate UDTS	None

* A partial failure occurs if some Service Module cards are available but are overloaded.

2.7 MT-Based GSM SMS NP

The Mobile Terminated-Based GSM SMS NP feature allows wireless operators to route short message service (**SMS**) messages destined to mobile subscriber within a number portability environment. If the Mobile Terminated (MT)-Based GSM SMS NP feature is not enabled and turned on, then messages are processed by the G-Port feature.

The MT-Based GSM SMS NP feature allows database lookup to be performed on short message service (SMS) messages that are routed from a short message service center (**SMSC**).

The MT-Based GSM SMS NP feature intercepts SRI_SM messages and sends response messages with routing information for out-of-network destination subscribers using the following process:

1. An SRI_SM message is intercepted by the EAGLE before the message reaches the home location register (**HLR**).
2. The message destination address (SCCP Called Party GTA) is extracted, the digits are conditioned, and lookup is performed in the database.
3. If the destination address/subscribers belongs to a foreign network, then a reply message is sent to the SMSC with routing information. If the destination address/subscribers belongs to a local network, then the SRI_SM message is relayed to the HLR.

2.7.1 Options

The MT-Based GSM SMS NP feature provides configurable options for controlling processing of SRI_SM messages and the content of the response:

- Selecting the SMSC response message type and digit format
- Specifying when a database lookup is considered to be successful
- Specifying the format of digits encoded in the response message.

2.7.2 Feature Control Requirements

The MT-Based GSM SMS NP feature has the following control requirements:

- The `defcc` parameter in the `chg-stpopts` command must be set to a value other than **none** before the feature can be turned on.
- The `defmcc` parameter in the `chg-gsmopts` command must be set to a value other than **none** before the feature can be turned on.
- A FAK for part Part number 893-0200-01
- The G-Port feature must be enabled before the MT-Based GSM SMS NP feature can be enabled.
- The G-Port feature must be turned on before the MT-Based GSM SMS NP feature can be turned on.
- The MT-Based GSM SMS NP feature cannot be enabled if the LNP feature is enabled.
- A temporary FAK cannot be used to enable the feature.
- The feature cannot be turned off after it has been turned on.

2.7.3 System Options for MT-Based GSM SMS NP

The system level options that control the MT-Based GSM SMS NP feature are stored in the GSMSMSOPTS database table. The MT-Based GSM SMS NP feature must be enabled before the following options in the GSMSMSOPTS table can be provisioned.

The content of the GSMSMSOPTS table is used to help perform number conditioning, response generation, and other feature-specific options. [Table 2-8](#) shows the options stored in the GSMSMSOPTS table, their possible values, and the action taken for each value.

Table 2-8 MT-Based GSM SMS NP Options

GSMSMSOPTS Option	Value	Action in the EAGLE
MTSMSIMSI	RN	This setting specifies the required format of digits which will be encoded in the "IMSI" parameter of the SRI_SM return result response (ACK).
	RNDN	
	CCRNDN	

Table 2-8 (Cont.) MT-Based GSM SMS NP Options



GSM SMS OPTS Option	Value	Action in the EAGLE
	DN	<div style="border: 1px solid blue; padding: 5px; margin-top: 10px;">  Note: The MT-Based GSM SMS NP feature will require STPOPTS:DefCC to be set before the feature can be activated. Also, DefCC will not be allowed to change to "NONE" as long as this feature is turned ON. </div>
	SRFIMSI	IMSI is encoded from the "SRFIMSI" parameter from the RTDB entity.
	MCCRNDN (default)	IMSI is encoded as MCCRNDN. The MCC will be encoded using the GSM OPTS:DefMCC setting.
		<div style="border: 1px solid blue; padding: 5px; margin-top: 10px;">  Note: The MT-Based GSM SMS NP feature requires GSM OPTS:DefMCC to be set before the feature can be turned on. GSM OPTS:DefMCC will not be allowed to change to "NONE" as long as this feature is turned ON. </div>
MTSMSNNI	RN (default) RNDN CCRNDN DN	This setting specifies the required format of digits which will be encoded in the "Network Node Number" parameter ISDN digits field within the LocationInfoWithLMSI TCAP parameter in the of the SRI_SM response (ACK). In the response, the Nature of Number field will always be encoded as "International" (0x1) and the numbering plan will always be encoded as ISDN/ Telephony Numbering (Rec ITU-T E.164) (0x1).
	SRFIMSI	IMSI is encoded from the "SRFIMSI" parameter from the RTDB entity.

Table 2-8 (Cont.) MT-Based GSM SMS NP Options



GSM SMS OPTS Option	Value	Action in the EAGLE
	MCCRNDN	IMSI is encoded as MCCRNDN. The MCC will be encoded using the GSM OPTS:DefMCC setting.
		<div style="border: 1px solid blue; padding: 5px; background-color: #e6f2ff;">  Note: The MT-Based GSM SMS NP feature requires GSM OPTS:DefMCC to be set before the feature can be turned ON. GSM OPTS:DefMCC will not be allowed to change to "NONE" as long as this feature is turned ON. </div>
	NONE	This parameter is not encoded in the response message. The LocationInfoWithLMSI TCAP parameter is included; the Network Node number sub-parameter is present; however the length of the parameter is 0.
MTSMSTYPE	SP	When the lookup in the RTDB has entitytype=SP, then the lookup is considered successful.
	RN (default)	When the lookup in the RTDB has entitytype=RN, then the lookup is considered successful.
	SPRN	When the lookup in the RTDB has entitytype=SP or RN, then the lookup is considered successful.
	ALL	When the lookup in the RTDB has entitytype=SP or RN or no_entity, then the lookup is considered successful.
	NONSP	When the lookup in the RTDB does not have an entitytype SP, then the lookup is considered successful. This could mean that no entity was found or an entity with type RN was found.
		<div style="border: 1px solid blue; padding: 5px; background-color: #e6f2ff;">  Note: This option is applied to messages in which the source is considered to be a Home SMSC. </div>
MTSMSACKN	ACK (default)	This indicates that when the SRI_SM lookup is considered successful, a SRI_SM_ACK (Return Result Last) is sent back.

Table 2-8 (Cont.) MT-Based GSM SMS NP Options



GSM SMS OPTS Option	Value	Action in the EAGLE
	NACK	This indicates that when SRI_SM look is considered successful, a SRI_SM_NACK (Return Error) is sent back.
		 Note: This option is applied to messages in which the source is considered to be a Home SMSC.
MTSMSDLTR	NO (default)	This option specifies if delimiter digit(s) need to be inserted in the MTSMSIMSI and MTSMSNNI digits. A value of NO means that no delimiter is inserted.
	PRERN	This option specifies that a delimiter (MTSMSDLTRV) is to be inserted before the RN when the RN is used in the MTSMSIMSI and MTSMSNNI digits. (RN included in the digit format is MTSMSDLTRV + RN from RTDB)
	POSTRN	This option specifies that a delimiter (MTSMSDLTRV) is to be inserted after the RN when the RN is used in the MTSMSIMSI and MTSMSNNI digits. (RN included in the digit format is RN from RTDB + MTSMSDLTRV)
MTSMSDLTRV	1-5 hex digits	This specifies if delimiter digit(s) need to be inserted in the MTSMSIMSI and MTSMSNNI if required (per MTSMSDLTR). This value can consist of 1-5 hexadecimal digits. A value must be defined here before MTSMSDLTR can be set to PRERN or POSTRN. Once set, the MTSMSDLTRV can never be configured to "NONE" again.

Table 2-8 (Cont.) MT-Based GSM SMS NP Options

GSMSMSOPTS Option	Value	Action in the EAGLE
MTSMSNAKERR	0-255 (default is 0x1 - Unknown Subscriber)	This specifies the TCAP error choice code to be included in the SRI_SM_ACK generated by SMS_MT.

 **Note:**

This option will affect only the Error code choice byte. Certain error code choices (e.g., systemFailure and callBarred) have additional mandatory data as per GSM specifications. However, the MT-Based GSM SMS NP feature will not encode any additional data in SRI_SM_NACK.

 **Note:**

The MTSMSNAKERR is applicable to responses generated to both the SMSC and MMSC.

Table 2-8 (Cont.) MT-Based GSM SMS NP Options

GSMSMSOPTS Value Option	Action in the EAGLE
MTSMSCHKSRC YES	<p>This parameter value specifies that the SCCP CgPA GTA of the message will be used to determine whether the source of the message is a Home SMSC.</p> <p>If this option is set to YES and the SCCP CgPA GTA is present and there is not a match in the Home SMSC list, the source of the message is not considered to be a Home SMSC. In this case, the message is considered inapplicable for MT-SMS processing.</p> <p>If this option is YES and SCCP CgPA GTA is not present or has a 0 length, then it is assumed that the source is a Home SMSC.</p> <p>If this option is YES and SCCP CgPA GTA is present and there is a match in the Home SMSC list, then the message source is considered to be Home SMSC.</p>

 **Note:**

The order of checks performed follows:

1. Home MMSC check is performed. If a Home MMSC check is to be performed (The MT-Based GSM MMS NP Feature is turned ON and GSMSMSOPTS: MTMMMSGTA is not "NONE"), the SCCP CgPA GTA will be compared against GSMSMSOPTS: MTMMMSGTA for a match. A match identifies the source to be a Home MMSC. This option (MTSMSCHKSRC) does not influence this first check for Home MMSC.

Table 2-8 (Cont.) MT-Based GSM SMS NP Options

GSMSMSOPTS Option	Value	Action in the EAGLE
SRISMDN	SCCP	<ul style="list-style-type: none"> • After number conditioning, G-Port uses the SCCP CdPA as the database search key for SRI_SM messages. • MNP Circular Routing (MNPCR) uses the SNAI processing of G-Port to determine if the DN of the incoming SRI_SM message contains an RN concatenated with the DN. If no RN is present, then the entire DN is used as the database search key after number conditioning. • If an RN is present, the HomeRN table is searched to determine: <ul style="list-style-type: none"> - if the RN is a HomeRN to be stripped from the DN before performing the query. - if the RN is not a HomeRN allowing the entire DN to be used as the database search key.
	NO (default)	<p>This parameter value specifies that EAGLE will not validate the SCCP CgPA GTA for Home SMSC check. If the initial check for Home MMSC is not successful and if this option is NO, then the source is assumed to be Home SMSC.</p> <p>This option may be used by the service provider to disable SCCP CgPA-checking for Home SMSC check, if the service provider ensures that only in-network nodes will send SRI_SM and receive the response generated by this feature.</p>

2. If the Home MMSC check is not successful, AND MTSMCHSR C is YES, then Home SMSC check is required if SCCP CgPA GTA is present.

Table 2-8 (Cont.) MT-Based GSM SMS NP Options

GSMSMSOPTS Option	Value	Action in the EAGLE
	TCAP	<ul style="list-style-type: none"> • G-Port decodes up to 22 digits in the MSISDN of the SRI_SM message. The 22nd digit can only be a STOP (x0F) digit; in this case, G-Port strips the last digit and uses the remaining digits to perform number conditioning for database lookup. • G-Port conditions the decoded MSISDN number to International number based on the NAI value of the MSISDN. • If the number of digits is greater than 15 after number conditioning is performed, the MSU falls through to GTT and UIM 1246 is issued. • After number conditioning, G-Port uses the MAP MSISDN as the database search key for SRI_SM messages. • HomeRN prefix deletion from SRI_SM messages is performed only when MNP Circular Route Prevention (MNPCRP) is turned on. This is similar to SRI message processing when SRIDN=TCAP. • If MNPCRP is turned on and a circular route is detected, then MNPCRP processing is applied to the SRI_SM message. • If the SRI_SM message is to be relayed after deleting HomeRN lookup results in SP, the TCAP section of the SRI_SM message is reformatted and the HomeRN digits are removed from the MSU. • If GSMSOPTS parameter SRISMGTTTRTG=ON and an MT-Based GSM SMS NP response is not required, then to comply with GTT the SCCP CdPA digits are conditioned to international number (CC+NDC+SN) depending on the SNAI. <p>An SRI_SM Nack is generated if decoding the TCAP MSISDN parameter of the SRI_SM returns an error for any of these reasons:</p> <ul style="list-style-type: none"> • Length field of TCAP MSISDN parameter is invalid. • Length of MSISDN is less than the mandatory fixed length. • The number of digits is zero or greater than 21. (UIM 1294 is generated.)

2.7.4 MT-Based GSM SMS and MMS NP Call Flows

This section illustrates the sequence of messages that occur in the processing of SMS and MMS messages destined for mobile-terminated subscribers in a number portability environment. Two scenarios exist:

- The called subscriber that is in the same network as the calling subscriber

- The called subscriber that is in a different network from the calling subscriber

MT-Based GSM SMS and MMS NP Call Flow for In-Network Subscriber

Figure 2-8 depicts the message and control flows for a called subscriber that is in the same network as the calling subscriber.

Figure 2-8 MT-Based GSM SMS and MMS NP Call Flow for In-Network Subscriber

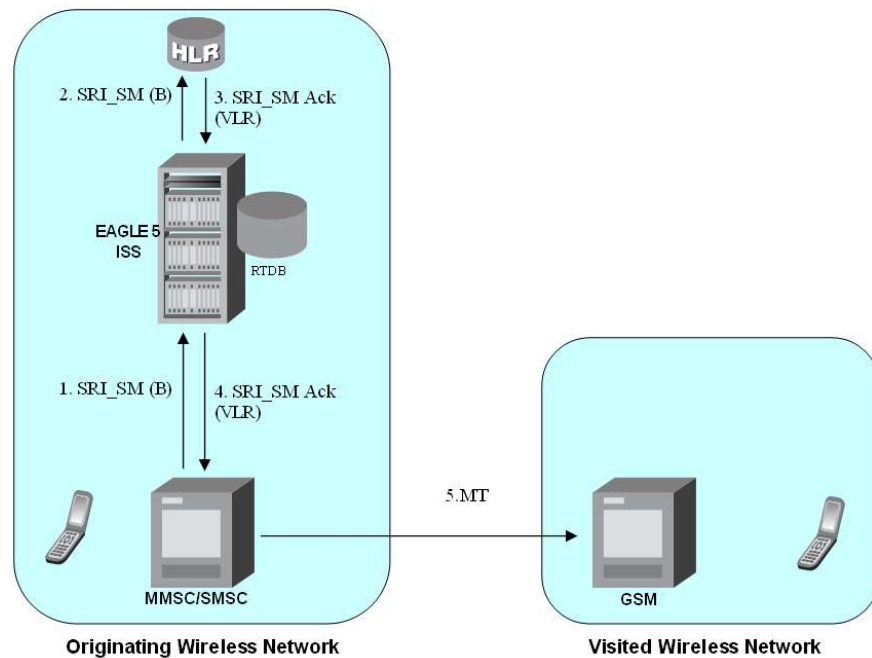

Call considerations:

- The TCAP calling party is a wireless GSM subscriber.
- The TCAP called party is a non-ported or ported-in wireless subscriber that belongs to the same carrier.
- The call type is SMS or MMS.
- SMSC has to be reconfigured to generate SRI_SM to the HLR, regardless of called subscriber number being in or out of its own numbering range.
- In case called subscriber is ported-in, it has to be provisioned individually.
- In case called subscriber is TDMA, the EAGLE Migration feature ensures that the message gets delivered in the TDMA network.

MT-Based GSM SMS and MMS NP Call Flow for Other-Network Subscriber

Figure 2-9 depicts the message and control flows for a called subscriber that is a different network from the calling subscriber.

Figure 2-9 MT-Based GSM SMS and MMS NP Call Flow for Other-Network Subscriber

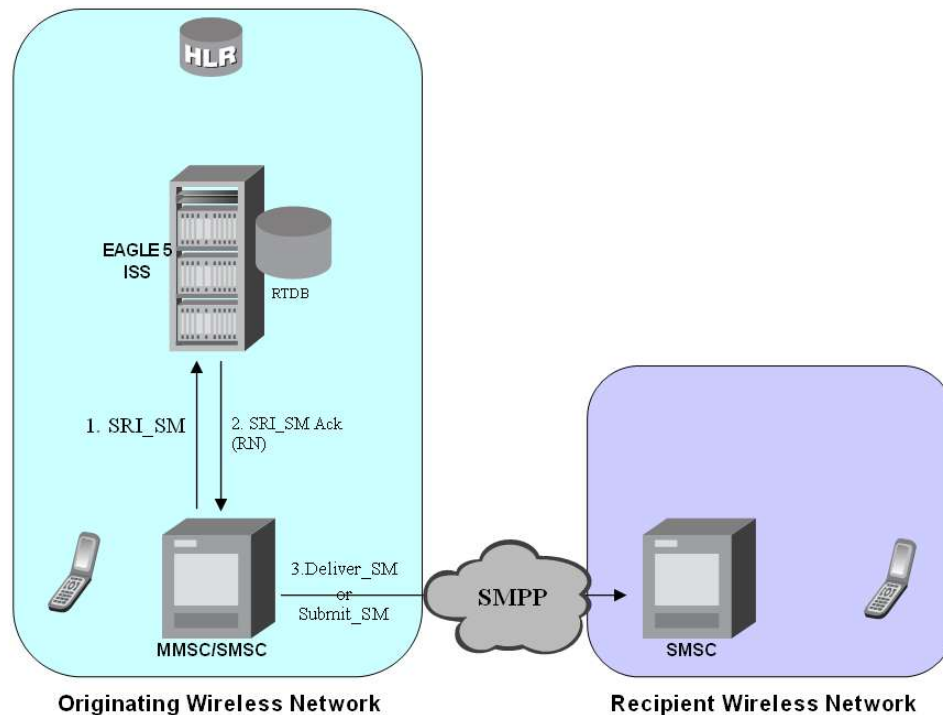

Call considerations:

- The TCAP calling party is a wireless GSM subscriber.
- The TCAP called party is a non-ported or ported-out wireless subscriber that belongs to a different carrier from the TCAP calling party.
- The call type is SMS or MMS.
- The SMSC (Short Message Service Center) has to be configured to associate the RNs to their respective carriers.
- The called subscriber must be provisioned individually.

2.8 MT-Based GSM MMS NP

The Mobile Terminated (**MT**)-Based GSM MMS NP feature allows wireless operators to route Multimedia Message Service (**MMS**) messages destined to mobile subscriber within a number portability (**NP**) environment. If the MT-Based GSM MMS NP feature is not enabled and turned on, then messages are processed by the G-Port feature.

The Mobile Terminated (**MT**)-Based GSM MMS NP feature allows database lookup to be performed on **MMS** messages that are routed from a Multimedia Message Service Center (**MMSC**).

The MT-Based GSM MMS NP feature intercepts SRI_SM messages and sends response messages with routing information for out-of-network destination subscribers using the following process:

1. An SRI_SM message is intercepted by the EAGLE before it reaches the home location register (**HLR**).
2. The message destination address (SCCP Called Party GTA) is extracted, the digits are conditioned, and lookup is performed in the database.
3. If the destination address/subscribers belongs to a foreign network, then a reply message is sent to the MMSC with routing information. If the destination address/subscribers belongs to a local network, then the SRI_SM message is relayed to the HLR or according to the options set for normal G-Port routing.

2.8.1 Options

The MT-Based GSM MMS NP feature provides the following configurable options for controlling processing of Multimedia Message Service (**MMS**) routing request messages and the content of the response:

- Selecting the Multimedia Message Service Center (**MMSC**) response message type and digit format
- Specifying when a database lookup is considered to be successful
- Specifying the format of digits encoded in the response message
- Specifying the number of digits in the SRI_SM ACK response message

2.8.2 Feature Control Requirements

The MT-Based GSM MMS NP feature has the following control requirements:

- The MT-Based GSM MMS NP feature must be enabled and turned on.
- A FAK for part Part number 893-0241-01
- The feature cannot be turned off after it has been turned on.
- A temporary FAK cannot be used to enable the feature.

2.8.3 System Options for MT-Based GSM MMS NP

The system level options that control the MT-Based GSM MMS NP feature are stored in the GSMSMSOPTS database table. The MT-Based GSM MMS NP feature must be enabled before the GSMSMSOPTS table can be provisioned.

The content of the GSMSMSOPTS table is used to help perform number conditioning, response generation, and other feature-specific options. [Table 2-9](#) shows the feature-specific options stored in the GSMSMSOPTS table, their possible values, and the action taken for each value.

Note:

The options described in [Table 2-9](#) are accessible only when the MT-Based GSM MMS NP feature is enabled. Processing of MSUs from MMSCs will also require the use of the GSMSMSOPTS options described for the MT-Based GSM SMS feature in [Table 2-8](#).



Table 2-9 MT-Based GSM MMS NP Options

GSMMSOPTS	Value	Action in the EAGLE
MTMMSGTA	5-21 hex digits (default is NONE)	<p>This option pertains to Home MMSC check. When an SCCP CgPA GTA is present in the message, this option is used to compare the SCCP CgPA GTA of the incoming SRI_SM message to determine whether the originator is a Home MMSC. If a match is found, the MTMMSTYPE and MTMMSACKN options are used to determine whether SRI_SM ACK or NACK is to be sent, and the conditions when lookup is considered to be successful for MMS.</p> <p>The nature of match is a “Prefix match”. That is, the leading digits must match all the digits provisioned in MTMMSGTA.</p>
		<p>This option can be set to NONE at any time. A value of NONE implies that the special processing of MMS is not required, and MT-Based SMS NP processing will follow. A setting of NONE will not match any SCCP CgPA GTA.</p>
MTSMSTYPE	SP	When the lookup in the RTDB has entitytype=SP, then the lookup is considered successful.
	RN (default)	When the lookup in the RTDB has entitytype=RN, then the lookup is considered successful.
	SPRN	When the lookup in the RTDB has entitytype=SP or RN, then the lookup is considered successful.
	ALL	When the lookup in the RTDB has entitytype=SP or RN or no_entity, then the lookup is considered successful.
	NONSP	When the lookup in the RTDB does not have an entitytype SP, then the lookup is considered successful. This could mean that no entity was found or an entity with type RN was found.

 **Note:**

The digits for compare can have more than the number of digits configured in MTMMSGTA

Table 2-9 (Cont.) MT-Based GSM MMS NP Options

GSMMSOPTS	Value	Action in the EAGLE
		<p> Note:</p> <p>This option is applied to messages in which the source is considered to be a Home SMSC.</p> <p>Duplicate options are provided for this parameter for MTMMS and MTSMS in order to be able to control processing of messages from the Home MMSC independently from those coming from a Home SMSC.</p>
MTMMSACKN	ACK (default)	This indicates that when the SRI_SM lookup is considered successful, a SRI_SM_ACK (Return Result Last) is returned.
	NACK	This indicates that when SRI_SM lookup is considered successful, a SRI_SM_NACK (Return Error) is returned.
		<p> Note:</p> <p>This option is applied to messages in which the source is considered to be a Home SMSC.</p> <p>Duplicate options are provided for this parameter for MTMMS and MTSMS in order to be able to control processing of messages from the Home MMSC independently from those coming from a Home SMSC.</p>
MTMMSENTYLE	1 - 15 (default is NONE)	This indicates the maximum number of digits used from the entity value of a returned RN, SP, or SRFIMSI entity for MMS processing. Digits that exceed the configured maximum are concatenated. numbers. The parameter value <i>NONE</i> indicates that all returned digits are used.
N		
MTMMSLEN	1 - 24 (default is NONE)	This indicates the maximum number of digits used in the returned IMSI or NNN fields for MMS processing. Digits that exceed the configured maximum are concatenated. numbers. The parameter value <i>NONE</i> indicates that all digits are used.

2.8.4 MT-Based GSM MMS NP Call Flows

The MT-Based GSM MMS NP feature call flows are identical to those used by the MT-Based GSM SMS NP feature and are described in [MT-Based GSM SMS and MMS NP Call Flows](#).

2.9 G-Port SRI Query for Prepaid

When the G-Port SRI Query for Prepaid feature is enabled and turned on, incoming SRI TT, OPC, and GTA values are compared against the values in the GSERV table. If no match is found, or if no values are provisioned in the GSERV table, normal G-Port SRI processing is performed on the message. If a match is found for one or more of the values, the message is treated as a Prepaid Query. The G-Port SRI Query for Prepaid feature affects only SRI messages. All other messages, including SRI-SM and SRI-GPRS messages, are processed by normal G-Port service.

After an SRI message is identified as requiring G-Port SRI Query for Prepaid service, the EAGLE performs a Mobile Number Portability (MNP) database lookup on the Mobile Station Integrated Services Digital Number (MSISDN). The results of the lookup are returned to the SCP that originated the query.

A TCAP/MAP error specifically related to a decoding error in the SRI MSISDN parameter causes an “Unsupported/Unexpected Data Value” MAP error. All other TCAP/MAP errors cause the message to be relayed to a Home Location Register (HLR), which then returns the appropriate MAP error based on the status of the subscriber (e.g. Unknown, Barred, etc.)

If a TCAP error is detected, then the message relay is based on information in the Real Time Database (RTDB). SCCP level errors cause the return on a UDTs message to the Prepaid SCP.

The G-Port SRI Query for Prepaid feature requires a Feature Access Key and cannot be turned off after it is turned on.

Service Portability support for G-Port SRI Query for Prepaid

Service Portability support for the G-Port SRI Query for Prepaid feature allows the RTDB GRN Entity digits to be used in digits formats for **own-network** GSM and IS41 subscribers in place of the SP entity digits or RN/PT=0 entity digits, where RN or SP is Network Entity Type and PT is Portability Type.

The Service Portability support for the G-Port SRI Query for Prepaid feature requires a Feature Access Key. The Service Portability feature can be turned off after it is turned on.

The SPORTTYPE configuration option indicates whether Service Portability will apply to SRI Query for Prepaid messages for own-network subscribers (IS41, GSM, or all). When Service Portability is applicable, GRN digits are used in place of RN digits during construction of the MSRN.

The Default RN configuration option is applicable in general to Number Portability, and can be used whether Service Portability feature is on or off. When the Service Portability feature is on, the Default RN is applicable in cases where Service Portability usage of GRN does not apply. Refer to [Table 2-10](#) and [Table 2-11](#). When the Service Portability feature is off, Default RN digits can be used for own-network subscribers during construction of the MSRN. Refer to [Table 2-12](#).

G-Port SRI Query for Prepaid must be enabled to provision the GSMOPTS:DFLTRN option. Both G-Port SRI Query for Prepaid and Service Portability must be enabled to provision the GSMOPTS:SPORTTYPE option. RTDB DN data must be provisioned with RN or SP entity for Service Portability support for the G-Port SRI Query for Prepaid feature. Other EPAP-related features that use the GRN field are mutually exclusive with the Service Portability feature.

Table 2-10 RN Digits for Subscriber Type = RN/0 (Own Subscriber - IS41) with Service Portability On

GSMOPTS:SPORTTYPE Value	GSMOPTS:DFLTRN = NONE	GSMOPTS:DFLTRN = DIGITS
NONE	RN=RTDB RN Entity ID	RN=DFLTRN
GSM	RN=RTDB RN Entity ID	RN=DFLTRN
IS41	RN=GRN If GRN is not provisioned, DFLTRN is not used. MSISDN digits are sent. The subscriber is incorrectly provisioned and needs to have a GRN assigned.	
ALL	RN=GRN If GRN is not provisioned, DFLTRN is not used. MSISDN digits are sent. The subscriber is incorrectly provisioned and needs to have a GRN assigned.	

Table 2-11 RN Digits for Subscriber Type = SP (Own Subscriber - GSM) with Service Portability On

GSMOPTS:SPORTTYPE Value	GSMOPTS:DFLTRN = NONE	GSMOPTS:DFLTRN = DIGITS
NONE	RN=RTDB SP Entity ID	RN=DFLTRN
GSM	RN=GRN If GRN is not provisioned, DFLTRN is not used. MSISDN digits are sent. The subscriber is incorrectly provisioned and needs to have a GRN assigned.	
IS41	RN=RTDB SP Entity ID	RN=DFLTRN
ALL	RN=GRN If GRN is not provisioned, DFLTRN is not used. MSISDN digits are sent. The subscriber is incorrectly provisioned and needs to have a GRN assigned.	

Table 2-12 RN Digits with Service Portability Off

Subscriber Type returned from RTDB	GSMOPTS:DFLTRN = NONE	GSMOPTS:DFLTRN = DIGITS
RN/PT = 0	<i>IGM feature ON or OFF:</i> RN=RTDB RN Entity ID	<i>IGM feature ON:</i> RN=DFLTRN <i>IGM feature OFF:</i> RN=RTDB RN Entity ID
SP (own GSM)	<i>IGM feature ON or OFF:</i> RN=RTDB SP Entity ID	<i>IGM feature ON or OFF:</i> RN=DFLTRN

Table 2-12 (Cont.) RN Digits with Service Portability Off

Subscriber Type returned from RTDB	GSMOPTS:DFLTRN = NONE	GSMOPTS:DFLTRN = DIGITS
RN/PT ≠ 0 (Other Licensed Operator)	IGM feature ON or OFF: RN = RTDB RN Entity ID	
No Entity Found	IGM feature ON or OFF: RN=EMPTY (Only B-Party Number)	

Figure 2-10 Message Processing - Service Portability Support for SRI Query for Prepaid

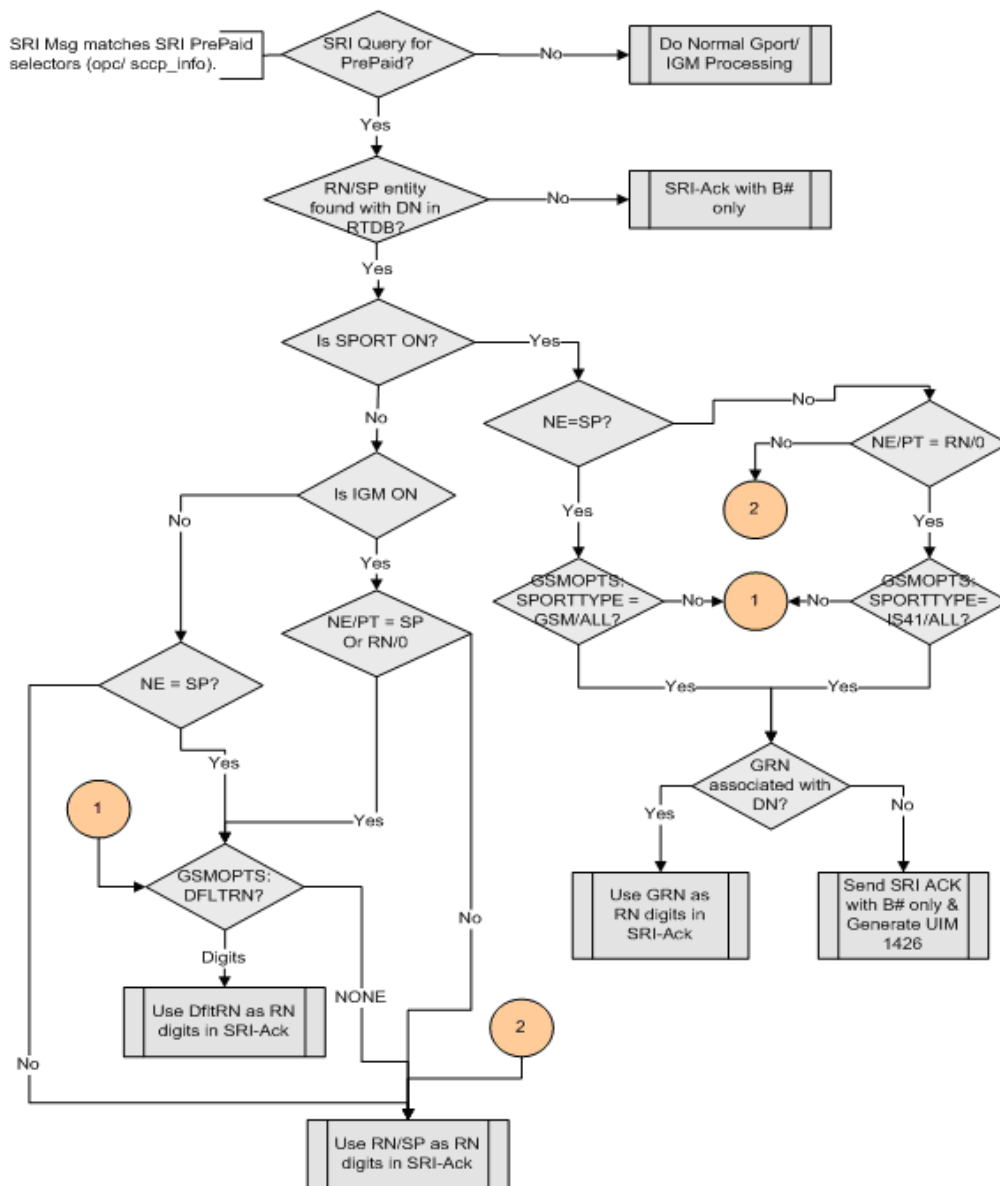

2.10 GSM MAP SRI Redirect to Serving HLR

The GSM MAP SRI Redirect to Serving HLR feature provides the capability to resolve network problems introduced by maintaining equipment from multiple manufacturers with vendor-specific proprietary implementations. Normally, the G-Port feature relays an SRI message to an operator's own HLR for a ported-in number. This feature allows the operator to route those messages based on the type of equipment at the source MSC and destination HLR. Vendor Type, Vendor Number, and Vendor Prefix are used to provision this information.

If the originating Mobile Switching Center (MSC) of the Send Route Information (SRI) message and the destination Home Location Register (HLR) are the same vendor type, the message is relayed to the HLR associated in the RTDB to the service provider. If the originating MSC of the SRI message and the destination HLR are not the same vendor type, G-Port checks whether the vendor type is deployed in more than one network; each network has its own vendor/network prefixes. MSC SRI message Home Location Register (HLR)

If the vendor types of the originating MSC and destination HLR are different and the destination HLR vendor type is deployed in more than one network, the vendor/network prefix that points to the network where the hosting HLR resides is appended. If the vendor types of the originating MSC and destination HLR are different and the vendor type of destination HLR is deployed in only one network, the vendor/network prefix that is assigned to the network is appended.

The GSM MAP SRI Redirect to Serving HLR feature supports provisioning of a Vendor Prefix List of up to 128 entries, a Vendor Type List of up to 32 entries, and a Vendor ID List of up to 500 entries. Each Vendor Prefix List entry (up to 128 entries) contains the Vendor Number and associated Vendor Prefix (maximum of six digits). Each Vendor ID List entry contains the Vendor ID, Vendor Type, and Vendor (network) Number. All Vendor IDs must be the same length which is provisionable for 1 to 15 digits using the `ent-vendid` command. A Vendor ID cannot be entered into the database until the associated Vendor Prefix is defined.

Table 2-13 Vendor Prefix List example

Vendor Number	Vendor Prefix
1	1004
2	1003
3	1004

Table 2-14 Vendor ID List example

Vendor/Network Type	Vendor Number	Vendor ID
1	1	886932
1	1	886935
1	3	886938
2	2	886936

Intra Network Number Portability

With the introduction of the Intra Network Number Portability feature and the new GSMOPTS:SRIRDCTENT option, the Generic Routing Number (GRN) can be used to identify intra-circle and inter-circle calls. Before the Intra Network Number Portability feature, the GSM MAP SRI Redirect to Serving HLR feature identified the serving HLR based on only the Circle Type and Circle Number for operators. With the Intra Network Number Portability feature, each Circle has a unique GRN, a unique Vendor Type, and a unique Vendor Number. The new GSMOPTS:SRIRDCTENT option has two possible values: GRN and SP. Intra Network Number Portability customers use the GSMOPTS:SRIRDCTENT option set to GRN. The GSM MAP SRI Redirect to Serving HLR feature must be enabled before the GSMOPTS:SRIRDCTENT option can be configured.

Table 2-15 Example: EPAP Provisioning for Intra Network Number Portability

DNs	GRN
All DNs of Circle1	GRN1
All DNs of Circle2	GRN2
All DNs of Circle3	GRN3

Table 2-16 Example: EAGLE Vendor ID Table for Intra Network Number Portability

Vendor ID	Vendor Type	Vendor Number
MSCGT1	T1	V1
MSCGT2	T2	V2
MSCGT3	T3	V3
GRN1	T1	V1
GRN2	T2	V2
GRN3	T3	V3

Table 2-17 Example: EAGLE Vendor PrefixTable for Intra Network Number Portability

Vendor Number	Vendor Prefix
V1	GRN1
V2	GRN2
V3	GRN3

If after RTDB lookup, SP and GRN are found corresponding to the DN, EAGLE uses GRN for lookup in the Vendor ID table. If the GRN is found in the Vendor ID table, EAGLE checks whether the CgPA has a valid length GTA. Then EAGLE uses the CgPA GTA to lookup in the Vendor ID table. If the CgPA GTA is found in the Vendor ID table, EAGLE compares the two vendor types associated with the CgPA GTA and the GRN.

Scenario 1 : If both Vendor Types are same, the CdPA and the originating MSC belong to the same circle. EAGLE relays the SRI message to the HLR as determined by the SP.

Scenario 2 : If the two vendor types are different, that means the CdPA and the originating MSC belongs to different circles. EAGLE generates an SRI_ACK using the Vendor Prefix (GRN of destination circle) as the RN. The SRI_ACK is then sent to the originating GMSC.

If after RTDB lookup, the RN is found corresponding to the DN then normal G-Port processing is continued.

Calling party / Operator	Called Party / Operator	Called Party Ported Status	Result
Circle 1 / Operator A	Circle 1 / Operator A	Not Ported	Relay
Circle 1 / Operator A	Circle 2 / Operator A	Ported to Circle 1 / Operator A	Relay
Circle 1 / Operator A	Circle 2 / Operator A	Ported to Circle 3 / Operator A	SRI_ACK with GRN3A
Circle 1 / Operator A	Circle 1 / Operator B	Not Ported	SRI_ACK with RN 1B
Circle 1 / Operator A	Circle 1 / Operator B	Ported to Circle 1 / Operator A	Relay
Circle 1 / Operator A	Circle 2 / Operator B	Ported to Circle 3 / Operator B	SRI_ACK with RN 3B
Circle 1 / Operator A	Circle 2 / Operator B	Ported to Circle 3 / Operator C	SRI_ACK with RN 3C
Circle 1 / Operator A	Circle 2 / Operator B	Ported to Circle 1 / Operator B	SRI_ACK with RN 1B
Circle 1 / Operator A	Circle 2 / Operator B	Ported to Circle 2 / Operator C	SRI_ACK with RN 2C

GSM MAP SRI Redirect to Serving HLR Call Flows

Refer to [Figure 2-11](#) for a graphical representation of the GSM MAP SRI Redirect to Serving HLR call flow. This call flows assumes that GSMOPTS:SRIRDCTENT=SP.

Figure 2-11 GSM MAP SRI Redirect to Serving HLR Call Flows

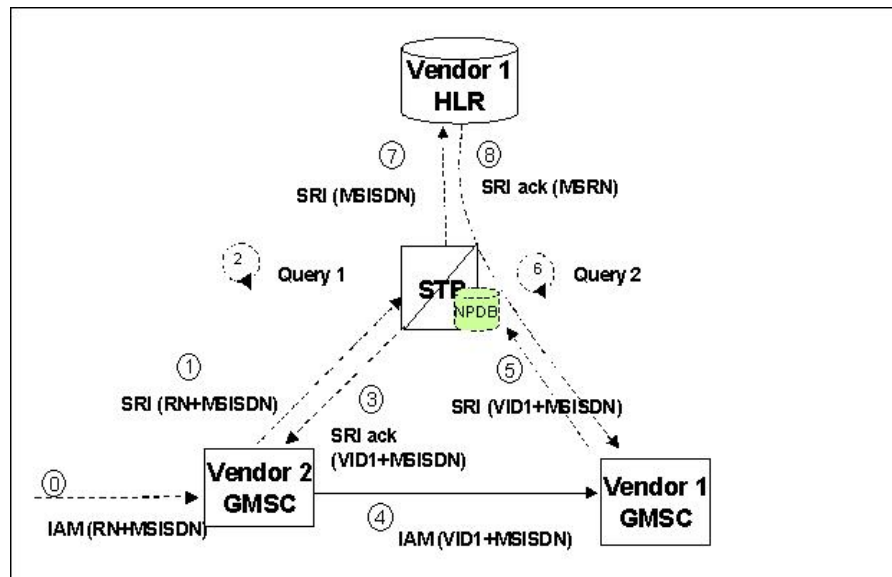

For a ported-in number, Gateway Mobile Switching Center (**GMSC**) Vendor 2 receives an Initial Address Message (**IAM**) with CdPN.

1. The receiving GMSC interrogates the Home Location Register (**HLR**) for the current location of the subscriber by issuing a Send Route Information (**SRI**) message.
2. When an SRI message is received that meets the G-Port service selector criteria, HomeRN deletion and number conditioning are performed on the **DN**. The DN database is searched. If the DN is found in the database with a service provider (HLR entity address) associated with the called party **MSISDN**, the Vendor ID list is searched for the service provider. If the service provider is found in the Vendor ID list, the **CgPA** is checked for a valid length **GTA**. The Vendor ID list is searched for the CgPA GTA. If the CgPA GTA is found in the Vendor ID list, the two vendor numbers associated with the CgPA GTA and the service provider are compared. If the GMSC and the HLR are the same vendor type, go to step #7. If the GMSC and the HLR are different vendor types, go to step #3.
3. If the destination network belongs to a vendor type that is deployed in more than one network, an SRI_ACK is generated using the Vendor Prefix of the destination network as the RN. The MSRN is filled using various options provisioned in the GSMOPTS table for the G-Port SRI_ACK. The SRI_ACK is sent to the originating GMSC.
4. Based on the Vendor Prefix, the originating GMSC routes the call to the GMSC of the network associated with the vendor by the IAM.
5. The subscription network GMSC formulates and sends an SRI message to the EAGLE to interrogate the current location of the subscriber.
6. G-Port performs a database lookup based on the MSISDN in the SRI and determines that the number belongs to its network. The service provider (HLR entity address) associated with the MSISDN and the CgPA GTA (GMSC/MSC) are confirmed to be the same vendor type. .
7. The SRI is relayed to the HLR associated to the service provider.
8. The HLR returns an SRI_ACK to the GMSC through the EAGLE.

2.11 Hardware Requirements

EPAP-related features that perform an RTDB lookup require Service Module cards (E5-SM4G, E5-SM8G-B, or SLIC cards) running the SCCPHC application. The EAGLE can be equipped with up to 32 (31+1) Service Module cards.

Features that do not perform an RTDB lookup require Service Module cards only for GTT processing that might be performed for the feature. These features can coexist in systems with EPAP, but do not require an EPAP connection.

2.12 MPS/EPAP Platform

Oracle provides the Multi-Purpose Server (MPS) platform as a subsystem of the Oracle Communications EAGLE. The MPS provides support for EPAP-related features that perform Real Time Database (RTDB) lookups.

The MPS is composed of hardware and software components that interact to create a secure and reliable platform. For details about the MPS hardware, refer to *Application B Card Hardware and Installation Guide*. The MPS provides the means of connecting

the customer provisioning application with the EAGLE and accepts the customer number portability data, while accommodating numbers of varying lengths.

The Oracle Communications EAGLE Application Processor (EPAP) is software that runs on the MPS hardware platform. EPAP collects and organizes customer provisioning data, and forwards the data to the EAGLE Service Module cards. For detailed information about EPAP, refer to *Administration Guide* for EPAP.

In this manual, Service Module card refers to an E5-SM4G, E5-SM8G-B, or SLIC card unless a specific card is required. For more information about the supported cards, refer to *Hardware Reference*.

3

Commands

This chapter contains brief descriptions of the EAGLE commands that are used for the configuration, control, maintenance, and measurements of the G-Port, MT-Based GSM SMS NP, and MT-Based GSM MMS NP features.

3.1 Introduction

This chapter describes the EAGLE commands used to administer the **MO SMS related** feature. The command descriptions include parameters that are used with the MO SMS related feature. Refer to *Commands User's Guide* for complete command descriptions including parameter names, valid parameter values, examples, and dependencies.

3.2 EAGLE Options Commands

The STP system options commands (`stpopts`) change and display STP-wide options in the EAGLE database. The following sections describe the commands: `chg-stpopts` and `rtrv-stpopts`. For details about these commands, refer to *Commands User's Guide*.

- **chg-stpopts: Change STP System Options Command** – The `chg-stpopts` command changes STP system options in the database. This command updates the STPOPTS table. The `defcc` and `defndc` parameters are used to convert non-international numbers received in the MSU to an international number. The `defcc` and `defndc` parameters can be specified only if the G-Port, Prepaid IDP Query Relay (IDPR), Prepaid SMS Intercept (PPSMS), V-Flex, or ATINP feature is enabled, or if the G-Flex, INP, or AINPQ feature is turned on.

Command example:

```
chg-stpopts: defcc=333: defndc=22345
```

Where:

`defcc`={1-3 digits, none} Default country code

`defndc`={1-5digits, none} Default network destination code

- **rtrv-stpopts: Retrieve STP System Options Command** – The `rtrv-stpopts` command is used to retrieve all STP options from the database. The options that appear in the output vary, depending on the features that are enabled or turned on.

3.3 EAGLE GSM Options Commands

The `gsmopts` commands change and display Global System for Mobile Telecommunications (GSM) options in the EAGLE database. The following sections

describe the two variations: `chg-gsmopts` and `rtrv-gsmopts`. For details about these commands, refer to *Commands User's Guide*.

chg-gsmopts

Change GSM Options Command – The `chg-gsmopts` command changes G-Port-specific system options in the database. This command updates the GSMOPTS table. The default parameters are always overwritten when specified.

Table 3-1 chg-gsmopts Parameters - Class = DATABASE

Parameter	Range	Description
crptt	0-255, none	Circular Route Prevention Translation Type The MNP Circular Route Prevention feature must be turned on before this parameter can be provisioned to any value other than <code>none</code> . The MNP Circular Route Prevention feature cannot be turned off if this parameter is provisioned to any value other than <code>none</code> . The default value is <code>none</code> .
defmapvr	1-3	Default MAP version
defmcc	1-3 digits, none	E212 default mobile country code
dftrn	1-15 digits, none	Default Routing Number This parameter specifies the default routing number to use as the routing number portion of the <code>msrndig</code> parameter when an SRI is processed by the G-Port SRI Query for Prepaid feature, an RTDB match is found for an own-network subscriber, and Service Portability is not applied. The default value is <code>none</code> .
gsm2is41	1-15 digits, none	GSM to IS41 migration prefix
is412gsm	1-15 digits, none	IS-41 to GSM migration prefix
migrpfx	multiple, single	Migration Prefix
msisdntrunc	1 digit (0-5)	Number of MSISDN digits to delete from the MISISDN before formulating the MSRN for the SRI Ack message
msrndig	rn, rndn, ccrndn, rnccdn, rnasd, asdrn, rnasddn, asdrndn, ccrnasddn, ccasdrndn, rnasdccd, asdrnccd, rngn, grnrn, rngrndn, grnrndn, ccrngrndn, ccgrnrndn, rngnccd, grnrnccd	RN used as <i>is</i> or with MSISDN
msrnlcn	1-30	Number of digits in the MAP Routing Info portion of the returned SRI Ack message. Default value is 30.
msrnnai	0-7	Nature of Address Indicator Value (NAIV) for the MSRN
msrnp	0-15	Numbering plan for the MSRN

Table 3-1 (Cont.) chg-gsmopts Parameters - Class = DATABASE

Parameter	Range	Description
multcc	1 to 3 digits (0-9, a-f, A-F)	Multiple Country Code
nmultcc	1 to 3 digits (0-9, a-f, A-F), none	New Multiple Country Code
off	encdnpsdnnotfound, encdnpsptnone, encodecug, encodenps, srismgttrtg	<p>This parameter turns off specified options. Up to 8 comma-separated unique options can be specified.</p> <ul style="list-style-type: none"> • encdnpsdnnotfound - NPSI for DN not found option This option specifies whether the NPSI is included in SRI Ack messages when the DN is not found. The default setting is <code>off</code>. • encdnpsptnone - NPSI for PT = none This option specifies whether the NPSI is included in SRI Ack messages when the Portability Type = none. The default setting is <code>off</code>. • encodecug - Closed User Group (CUG) option This option specifies whether the Closed User Group (CUG) Checkinfo from the SRI message is included in the SRI Ack message. The default setting is <code>off</code>. • encodenps - Number Portability Status Indicator (NPSI) option This option specifies whether the Number Portability Status Indicator (NPSI) is omitted from all SRI Ack messages. The default setting is <code>on</code>. • srismgttrtg - SRI_SM Routing option This option specifies whether the SRI_SM and ReportSMSDeliveryStatus routing to GTT is on. The default setting is <code>off</code>.
on	encdnpsdnnotfound, encdnpsptnone, encodecug, encodenps, srismgttrtg	This parameter turns on specified options. Up to 8 comma-separated unique options can be specified. Refer to <code>off</code> parameter for option descriptions.
serverpfx	1-4 digits, none	Server SRI prefix
sporttype	gsm, is41, all, none	<p>Service Portability Type</p> <p>This parameter specifies whether Service Portability applies to G-Port SRI Query for Prepaid for own-network subscribers. Default value is <code>none</code>.</p>
srfaddr	1-15 digits, none	Entity address of MNP_SRF node
srfnai	0-127	NAIV of the MNP_SRF

Table 3-1 (Cont.) chg-gsmopts Parameters - Class = DATABASE

Parameter	Range	Description
srfnp	0-15	Numbering plan value of the MNP_SRF Network Code
sridn	tcap, sccp	SRIDN location
sridnnotfound	gtt, srinack	When G-Port encounters an RTDB query result that indicates that the given DN is not known, the SRIDNNOTFOUND parameter value determines further processing. The default value is gtt.
srirdctent	grn, sp	This parameter indicates whether the Intra Network Number Portability feature (grn) or the MAP SRI Redirect to Serving HLR feature (sp) is used to match Vendor Type of CgPA GTA.

Command examples:

- `chg-gsmopts:srfnai=4:srfnp=2:srfaddr=331111111111`
- `chg-gsmopts:srfaddr=333221234567890:msrndig=rn:srfnai=1:srfnp=1:msrnnai=4 :msrnp=10`
- `chg-gsmopts:sridn=tcap`
- `chg-gsmopts:is412gsm=0123456789abcde`
- `chg-gsmopts:srirdctent=grn`

rtrv-gsmopts

Retrieve G-Port System Options Command

The `rtrv-gsmopts` command displays all GSM-specific system options from the database.

3.4 EAGLE GSM SMS Options Commands

The GSM SMS options (`gsmsmsopts`) commands change and display specific SMS and MMS options in the EAGLE database for the MT-based GSM SMS NP and MT-based GSM MMS NP features. The following sections describe the two variations: `chg-gsmsmsopts` and `rtrv-gsmsmsopts`. For details about these commands, refer to *Commands User's Guide*.

The `mtmmsackn`, `mtmmsentyn`, `mtmmsgta`, `mtmmslen`, and `mtmmstype` parameters apply to only messages that are modified by the MT-Based GSM MMS NP feature. The MT-Based GSM MMS NP feature must be enabled to specify these parameters.

The `mtsmsackn`, `mtsmschksrc`, `mtsmsdltr`, `mtsmsdltrv`, `mtsmsimsi`, `mtsmsnakerr`, `mtsmsnni`, and `mtsmstype` parameters apply to only messages that are modified by the MT-Based GSM SMS NP feature. The MT-Based GSM SMS NP feature must be enabled to specify these parameters.

chg-gsmsmsopts

Change GSM SMS Options Command – The `chg-gsmsmsopts` command changes GSM SMS system options in the database. This command updates the GSMSMSOPTS table. The default parameters are always overwritten when specified.

Table 3-2 chg-gsmsmsopts Parameters Class = DATABASE

Parameter	Range	Description
mtmmsackn	ack, nack	MT-based MMS acknowledgement
mtmmsentyle n	1-15, none	MT-based MMS entity length
mtmmsgta	5-21 digits, none	MT-based MMS GTA
mtmmslen	1-24, none	MT-based MMS length
mtmmstype	sp, rn, sprn, all, nonsp	MT-based MMS type
mtsmsackn	ack, nack	MT-based SMS acknowledgement
mtsmschksrc	yes, no	MT-based SMS check source
mtsmsdltr	no, prern, postrn	MT-based SMS delimiter
mtsmsdltrv	1-5 digits	MT-based SMS delimiter value
mtsmsimsi	rn, rndn, ccrndn, dn, srfimsi, mccrndn	MT-based SMS IMSI
mtsmsnakerr	0-255	MT-based SMS negative acknowledgement error
mtsmsnni	rn, rndn, ccrndn, dn, srfimsi, mccrndn, none	MT-based SMS network node indicator
mtsmstype	sp, rn, sprn, all, nonsp	MT-based SMS type SRI_SM DN location This parameter specifies whether the MT-Based GSM SMS NP feature selects the MSISDN from the SCCP CdPA or TCAP CdPN section of the SRI_SM message. The MT-Based GSM SMS NP feature must be enabled and turned on to specify this parameter.
srismdn	sccp, tcap	

Command example:

- `chg-gsmsmsopts:mtmmsgta=51111:mtmmstype=sp:mtmmsackn=nack:mtmmsentyle=7:mtmmslen=10`

rtrv-gsmsmsopts**Retrieve GSM SMS Options Command**

The `rtrv-gsmsmsopts` command displays all GSM SMS and MMS options from the database.

3.5 EAGLE G-Port Service Selector Commands

The G-Port service selector (`srvsel`) commands are used to provision new selectors for the G-Port service, providing greater flexibility when provisioning the type of messages that require G-Port processing. The following sections describe the four variants: `ent-srvsel`, `chg-srvsel`, `dlt-srvsel`, and `rtrv-srvsel`. For further details on the EAGLE G-Port service selector commands (such as command rules and output format), refer to *Commands User's Guide*.

ent-srvsel: Enter G-Port Service Selectors Command – The `ent-srvsel` command specifies that the applicable G-Port service selectors indicating G-Port processing are required. The available parameters are described in [Table 3-3](#).

Table 3-3 ent-srvsel Parameters - Class = DATABASE

Parameter	Range	Description
gti, gtia, gtii, gtin, gtin24	2, 4	Global Title Indicator
serv	eir, gflex, gport, inpq, inpmr, smsmr, idps, idpr, mnp, vflex, atinp	GSM service
snai	1sub, natl, intl, rnidn, rncdn, rnsdn, ccrndn	Service Nature Of Address Indicator
snp	1e164, e212, e214	Service Numbering Plan
ssn	0-255, *	Subsystem Number
tt	0-255	Translation Type
nai	sub, rsvd, natl, intl	Nature Of Address Indicator
naiv	0-127	NAI Value
np	e164, generic, x121, f69, e210, e212, e214, private	Numbering Plan
npv	0-15	Numbering Plan Value

chg-srvsel: Change G-Port Service Selector Command – The `chg-srvsel` command specifies the applicable G-Port selectors required to change an existing G-Port selector entry. The available parameters are described in [Table 3-4](#).

Table 3-4 chg-srvsel Parameters - Class = DATABASE

Parameter	Range	Description
gti, gtia, gtii, gtin, gtin24	2, 4	Global Title Indicator
ssn	0-255, *	Subsystem Number
tt	0-255	Translation Type
nai	sub, rsvd, natl, intl	Nature Of Address Indicator
naiv	0-127	NAI Value
np	e164, generic, x121, f69, e210, e212, e214, private	Numbering Plan

Table 3-4 (Cont.) chg-srvsel Parameters - Class = DATABASE

Parameter	Range	Description
npv	0-15	Numbering Plan Value
nserv	eir, gflex, gport, inpq, inpmr, smsmr, idpr, idps, mnp, vflex, atinp	New GSM service
nsnai	sub, natl, intl, rnidn, rnndn, rnsdn, ccrndn	New Service Nature Of Address Indicator
nsnp	e164, e212, e214, none	New Service Numbering Plan

dlt-srvsel: Delete G-Port Service Selector Command – The `dlt-srvsel` command deletes a **G-Port** service selector. The available parameters are described in [Table 3-5](#).

Table 3-5 dlt-srvsel Parameters - Class = DATABASE

Parameter	Range	Description
gti, gtia, gtii, gtin, gtin24	2, 4	Global Title Indicator
ssn	0-255, *	Subsystem Number
tt	0-255	Translation Type
nai	sub, rsvd, natl, intl	Nature Of Address Indicator
naiv	0-127	NAI Value
np	e164, generic, x121, f69, e210, e212, e214, private	Numbering Plan
npv	0-15	Numbering Plan Value

rtrv-srvsel: Retrieve G-Port Service Selector Command – The `rtrv-srvsel` command displays a list of administered G-Port service selector combinations. All output is sorted first by service, then by global title domain (ANSI first, followed by ITU), GTI, translation type, numbering plan, and by the nature of address indicator. The output can be filtered by specifying any optional parameter. The available parameters are described in [Table 3-6](#)

Table 3-6 rtrv-srvsel Parameters - Class = DATABASE

Parameter	Range	Description
gti, gtia, gtii, gtin, gtin24	2, 4	Global Title Indicator
nai	sub, rsvd, natl, intl	Nature Of Address Indicator
naiv	0-127	NAI Value
np	e164, generic, x121, f69, e210, e212, e214, private	Numbering Plan
npv	0-15	Numbering Plan Value

Table 3-6 (Cont.) rtrv-srvsel Parameters - Class = DATABASE

Parameter	Range	Description
serv	eir, gflex, gport, inpq, inpmr, smsmr, idps, idpr, mnp, vflex, atinp	GSM service
snai	sub, natl, intl, rnidn, rnndn, rnsdn, ccrndn	Service Nature Of Address Indicator
snp	e164, e212, e214	Service Numbering Plan
ssn	0-255, *	Subsystem Number
tt	0-255	Translation Type

3.6 EAGLE SCCP Service Commands

The `sccp-serv` commands allow for services to be taken online and offline and for their processing load to be shifted to other designated nodes. These commands also support the assignment of point codes to service groups used for service re-route assignment. Three variations are described in this section: `chg-sccp-serv`, `dlt-sccp-serv`, and `rtrv-sccp-serv`.

Entries using the `chg-sccp-serv` command are provisioned in the `SCCP-SERV` table, and are shown by the `rtrv-sccp-serv` command output. This reduces the maximum number of entries that the **MRN** table can contain by the number of entries shown in the `rtrv-sccp-serv` command output. For information on provisioning **MRN** tables, refer to *Database Administration - GTT User's Guide*.

Refer to *Commands User's Guide* for additional details about the EAGLE SCCP service commands.

chg-sccp-serv: Change SCCP Service Command – The `chg-sccp-serv` command is used to add point codes to an existing service group, or to change the Relative Cost (RC) of existing point codes in a group. SCCP Service groups are organized by service and point code network type (ANSI, ITU-I, ITU-I Spare, ITU-N, ITU-N Spare, or ITU-N24). Up to seven point codes may be in a network type grouping for service re-route load sharing. This command allows for additions or modifications of up to four point codes. The point code parameters support the Spare Point Code subtype prefix `s-` for ITU-I and ITU-N point codes.

Table 3-7 chg-sccp-serv Parameters - Class = DATABASE

Parameter	Range	Description
serv	gport, gflex, mnp	Service
gtt	no, yes	Global Title Translation
pc1, pca1, pci1, pcn1, pcn241	Refer to <i>Commands User's Guide</i>	Post GTT -translated PC
rc1	00-99	Relative Cost
pc2, pca2, pci2, pcn2, pcn242	Refer to <i>Commands User's Guide</i>	Post GTT-translated PC
rc2	00-99	Relative Cost

Table 3-7 (Cont.) chg-sccp-serv Parameters - Class = DATABASE

Parameter	Range	Description
pc3, pca3, pci3, pcn3, pcn243	Refer to <i>Commands User's Guide</i>	Post GTT-translated PC
rc3	00-99	Relative Cost
pc4, pca4, pci4, pcn4, pcn244	Refer to <i>Commands User's Guide</i>	Post GTT-translated PC
rc4	00-99	Relative Cost
state	offline, online	Service State

dlt-sccp-serv: Delete G-PortSCCP Service Command – The `dlt-sccp-serv` command is used remove entries from the SCCP Service table. A single command may remove either a PCU from a group or the entire group. The available parameters follow:

Table 3-8 dlt-sccp-serv Parameters - Class = DATABASE

Parameter	Range	Description
serv	gport, gflex, mnp	Service
pc1, pca1, pci1, pcn1, pcn241	Refer to <i>Commands User's Guide</i>	Post GTT-translated PC
pc2, pca2, pci2, pcn2, pcn242	Refer to <i>Commands User's Guide</i>	Post GTT-translated PC
pc3, pca3, pci3, pcn3, pcn243	Refer to <i>Commands User's Guide</i>	Post GTT-translated PC
pc4, pca4, pci4, pcn4, pcn244	Refer to <i>Commands User's Guide</i>	Post GTT-translated PC
all	no, yes	Yes deletes all point codes from a service

rtv-sccp-serv: Retrieve SCCP Service Command – The `rtv-sccp-serv` command is used to display the SCCP Service application relationship information maintained by the EAGLE. Point codes are grouped by service.

3.7 EAGLE Feature Control Commands

These commands are used to enable, turn on, and display the feature status of the G-Port, MNPCR, MT-Based GSM SMS NP, and MT-Based GSM MMS NP features on the EAGLE. Features must be purchased to have access to a Feature Access Key, which must be used when enabling these features. A separate **Feature Access Key** is required to enable each feature. You must be entitled to use a feature before it can be enabled. If you are not sure whether you are entitled to use a feature, contact your Oracle Sales Representative or Account Representative.

After the feature G-Port feature is turned on, it cannot be turned off. A temporary Feature Access Key is associated with the G-Port and MNPCR features.

enable-ctrl-feat: Enable Controlled Feature Command –The `enable-ctrl-feat` command is used for temporary and permanent enabling of controlled features. An example of the command using the G-Port part number is:

```
enable-ctrl-feat:partnum=893017201:fak=<Feature Access Key>
```

chg-ctrl-feat: Change Controlled Feature Command –The `chg-ctrl-feat` command is used to turn on controlled features: G-Port, MNPCRCP, MT-Based GSM SMS NP, and MT-Based GSM MMS NP. The MNPCRCP, MT-Based GSM SMS NP, and MT-Based GSM MMS NP features require the G-Port feature to be enabled as a prerequisite. This command is also used to turn off ON/OFF features and to clear the critical alarm caused by an expired temporary key.

Command example using the MNPCRCP part number:

```
chg-ctrl-feat:partnum=893007001:status=on
```

rtrv-ctrl-feat: Retrieve Controlled Feature Command–The `rtrv-ctrl-feat` command is used display the on/off status of controlled features and the trial period remaining for temporary enabled features.

4

Feature Configuration

This chapter describes the prerequisites, considerations, and steps to configure and activate the G-Port feature. This chapter also includes feature activation procedures for these features:

- MT-Based GSM SMS NP
- MT-Based GSM MMS NP
- G-Port SRI Query for Prepaid
- GSM MAP SRI Redirect to Serving HLR

4.1 Introduction

This chapter identifies prerequisites for the G-Port feature activation procedure and provides the feature activation procedures for the following features:

- G-Port
- MT-Based GSM SMS NP
- MT-Based GSM MMS NP
- G-Port SRI Query for Prepaid
- Service Portability support for G-Port SRI Query for Prepaid
- GSM MAP SRI Redirect to Serving HLR

These feature activation procedures are performed at the EAGLE.

The G-Port feature and other related features are optional and are purchased from Oracle. You must be entitled to use them in your system. Contact your Oracle Sales or Account Representative to determine whether you have purchased or are entitled to use a specific feature or for additional information. The following features are related to the G-Port feature:

- Global Title Translation (**GTT**)
- Enhanced Global Title Translation (**EGTT**)
- Variable-Length Global Title Translation (**VGTT**)
- EAGLE Application Processor (**EPAP**)
- Mobile Number Portability Circular Route Prevention (**MNPCR**)

In addition, the following performance-related feature is related to G-Port:

- E5-SM4G Throughput Capacity

 **Note:**

After a permanently-on feature has been enabled and turned on with the `enable-ctrl-feat` and `chg-ctrl-feat` commands, the feature cannot be turned off. Because this feature may affect other features or system databases, confirm that a feature license and technical support from Oracle are available before turning on this feature. Contact your Oracle Sales or Account Representative to verify whether you are entitled to use the feature has been purchased.

Summary of Feature Activation

This table summarizes the feature activation attributes for the features in this chapter.

Table 4-1 Feature Activation Summary

Feature Name	Part Number	Permanently On?
GSM Mobile Number Portability (G-Port)	893017201	Yes
MNP Circular Route Prevention (MNPCRP)	893007001	No
MT-Based GSM SMS NP	893020001	Yes
MT-Based GSM MMS NP	893024101	Yes
G-Port SRI Query for Prepaid	893017701	Yes
Service Portability	893034301	No
GSM MAP SRI Redirect to Serving HLR	893014001	Yes

4.2 EPAP Entity Provisioning

Oracle recommends that EPAP entity (**SP** or **RN**) administration not be performed until after the Point Code and/or Subsystem Number has been entered into the EAGLE MAP table.

- EPAP-administered entity data can become out-of-sync with the EAGLE MAP table when the creation of Point Codes and/or Subsystem Numbers in the MAP table is performed after EPAP database administration.
- If this mismatch is discovered in real-time operations, a UIM is sent to the EAGLE maintenance terminal. (Example UIMs: SCCP did not route - DPC not in MAP tbl, SCCP did not route - SS not in MAP tbl.)

4.3 Prerequisites

The G-Port feature activation assumes that the feature Global Title Translation (GTT), Enhanced Global Title Translation (EGTT), or Variable-Length Global Title Translation (VGTT) is already provisioned. Refer to *Database Administration - GTT User's Guide* for provisioning procedures.

The G-Port feature activation assumes that the EPAP software is already configured; refer to EPAP Software Configuration in *Administration Guide* for EPAP.

The G-Port feature activation assumes that the Service Module cards to be installed are identified.

- Note installed Service Module card locations, if any.
- Note available odd-even card slots for Service Module card installation.
- Determine Service Module card IP addresses and have the addresses available during the activation procedure.

For in-service systems, schedule Service Module card replacement during a maintenance window that allows the reboot of Service Module cards (`init-card`) one at a time.

For in-service systems with another EPAP-feature enabled, perform only [G-Port Feature Activation Procedure](#) to enable and turn on the G-Port feature. With another EPAP-feature enabled, the Service Module cards already contain the Real Time Database (**RTDB**).

For new systems, all Service Module cards may be rebooted at the same time using the `init-card:appl=vsccp` command. The GTT, EGTT, or VGTT feature must be turned on prior to adding the Service Module cards.

4.4 EAGLE HLR Configuration

This procedure configures the EAGLE system for Home Location Register (HLR) destinations before activating the **GSM Mobile Number Portability (G-Port)** feature. This procedure assumes that the EAGLE is an existing system in which the G-Port feature is being activated. The route to the HLR database may already be configured. Perform this procedure to verify that all HLR destinations for the feature are provisioned and to configure changes, as needed. The G-Port feature applies to ITU-I (international), ITU-N (national), and ANSI networks. Refer to *Commands User's Guide* for detailed descriptions of the commands used in this procedure.

Procedure Overview

- Display current PCs, CPCs, DPCs, routes, and linksets using [1](#) through [6](#).
- Change current PCs, CPCs, DPCs, routes, linksets, and LIM cards using [7](#) through [25](#).

For detailed information about specific configuration activities in this procedure, refer to *Database Administration - SS7 User's Guide*. Useful procedures include:

- Adding a Point Code to the Self-Identification of the EAGLE
 - Changing the Self-Identification of the EAGLE
 - Adding a Destination Point Code
 - Adding an SS7 Linkset
 - Adding an SS7 Signaling Link
 - Adding a Route Containing an SS7 DPC
1. Display the current self-identification characteristics (PC and CPC) of the system using the `rtrv-sid` command.

The **self-identification** characteristics of the system displayed by the `rtrv-sid` command include the **point code** (PC) assigned to the system, the **CLLI** code of

the system, the **capability point code** of the STP (CPC), and the type of point codes supported by the system.

If the **ITUDUPPC** (ITU national duplicate point code) feature is on, the ITU national point code also contains a group code. The group code is a two-character field from aa to zz that is entered as the last subfield of an ITU national point code, *nnnnn-gc* (for example, 2112-aa).

2. Display the current **destination point codes** (DPC) in the Destination point code table (*dpc/dpca/dpci/dpcn*) using the `rtrv-dstn` command.
3. Display the current route and linkset configuration using the `rtrv-rte` command.
4. If the system point code (*pci/pcn*) or capability point code (*cpc/cpca/cpci/cpcn*) to be configured in this procedure is shown in 1, 2, or 3, choose another point code to configure with this procedure. If configuring an ITU-N network, continue to 5. If configuring a mated application but not configuring an ITU-N network, proceed to 6. Otherwise, proceed to 7.
5. Use the `rtrv-stpopts` command to display the PC or CPC format when configuring the system point code or capability point code (*pcn* or *cpcn*) of an ITU-N network.

The ITU-N point code format option `npcfmti` determines the format of the ITU-N point code in the database and how it is displayed in all system outputs. The defined value is shown in the `NPCFMTI` field displayed in the output of the `rtrv-stpopts` command.

To change the format of the ITU-N point code, refer to "Point Code Formats" in *Database Administration - SS7 User's Guide*.

Continue to 6 to display mated applications in the database. Otherwise, proceed to 7.

6. Display the mated applications in the database using the `rtrv-map` command.
 - a. If the point code of the system is displayed in the `rtrv-map` command output (*PCA*, *PCI*, *PCN*, *MPCA*, *MPCI*, or *MPCN* fields), remove the system point code from the mated application table. Refer to procedure "Removing a Mated Application" in *Database Administration - Features User's Guide*.
 - b. If the point code of the system or capability point code is a destination point code of a route, select a point code that is not in the destination point code table (refer to output in 2) and not the destination point code of a route (refer to output in 3).
7. Change the point code of the system and capability point code by network type using procedures "Adding a Point Code to the Self-Identification of the EAGLE" and "Changing the Self-Identification of the EAGLE" in *Database Administration - SS7 User's Guide*.
8. Enter a destination point code for the **HLR** location in the Destination table by network type using the `ent-dstn` command.

Command examples:

```
ent-dstn:dpci=2-100-2
```

```
ent-dstn:dpcn=21112
```

where:

:dpc/dpca/dpci/dpcn

Destination point code to add to the database

- Verify the changes using the `rtrv-dstn` command and specifying the **DPC** entered in 8.

Command examples:

`rtrv-dstn:dpci=2-100-2``rtrv-dstn:dpcn=21112`Example of possible output for the **DPCI** command example:

tekelecstp51 09-08-24 21:16:37 GMT EAGLE 41.0.0

DPCI	CLLI	BEI	ELEI	ALIASA	ALIASN/N24	DMN
2-100-2	-----	no	---	-----	-----	SS7

Example of possible output for the **DPCN** command example:

tekelecstp51 09-08-24 21:16:37 GMT EAGLE 41.0.0

DPCN	CLLI	BEI	ELEI	ALIASA	ALIASI	DMN
21112	-----	no	---	-----	-----	SS7

- Enter a linkset with the `ent-ls` command and assign the linkset to the destination point code by network type.

Command examples:

`ent-ls:apci=2-200-2:lsn=ls400001:lst=a``ent-ls:apcn=21122:lsn=ls500001:lst=a`

where:

:apc/apca/apci/apcn

Adjacent point code - the DPC of the adjacent signaling node at the far end of the linkset

:lsn

Linkset name

:lst

Linkset type

- Verify the changes using the `rtrv-ls` command and specifying the linkset name.

Command example:

`rtrv-ls:lsn=ls400001``rtrv-ls:lsn=ls500001`Example of possible output for **lsn400001** command example:

tekelecstp51 09-08-24 21:16:37 GMT EAGLE 41.0.0

LSN	APCI	(SS7)	SCRN	SET	L3T	SLT	BEI	LST	LNKS	ACT	GWS	GWS	GWS	MES	DIS

```

SLSCI NIS
ls400001      2-200-2      scr1 1 2 no a 0 on off off
no on
CLLI          TFATCABMLQ MTPRSE ASL8
RLGHNCXA03W 1          no no
              L2T      L1          PCR PCR
LOC  PORT SLC TYPE  SET BPS  MODE TSET ECM  N1 N2

```

Example of possible output for **lsn500001** command example:

```

tekelecstp51 09-08-24 21:16:37 GMT EAGLE 41.0.0

              L3T SLT          GWS GWS GWS
LSN          APCN  (SS7)  SCR  SET SET BEI LST LNKS ACT MES DIS
SLSCI NIS
ls500001      21122          scr3 1 2 no a 0 on off off
no on
CLLI          TFATCABMLQ MTPRSE ASL8
RLGHNCXA03W 1          no no
              L2T      L1          PCR PCR
LOC  PORT SLC TYPE  SET BPS  MODE TSET ECM  N1 N2

```

12. Add the **LIM** cards to the database using the `ent-card` command.

Command examples:

```
ent-card:appl=ccs7itu:loc=1105:type=lime1
```

```
ent-card:appl=ccs7itu:loc=1106:type=lime1
```

where:

:appl

Specifies that the application is **CCS7ITU**.

:loc

Specifies the slot number for the card.

:type

Specifies that the card is a **LIME1** card.

13. Enter the E1 interface using the `ent-e1` command.

Command examples:

```
ent-e1:loc=1105:e1port=1
```

```
ent-e1:loc=1106:e1port=1
```

where:

:loc

Card location or slot as stenciled on the shelf

:e1port

E1 card port number

14. Verify the changes using the `rtrv-card` command with the card location specified.

Command examples:

```
rtrv-card:loc=1105
```

```
rtrv-card:loc=1106
```

Example of possible output for command example:

```
tekelecstp51 09-08-24 21:16:37 GMT EAGLE 41.0.0
```

CARD	TYPE	APPL	LSET NAME	LINK	SLC	LSET NAME
LINK	SLC					
1105	LIME1	CCS7ITU	ls400001	A	00	-----
B	--					
1106	LIME1	CCS7ITU	ls500001	A	00	-----
B	--					

15. Assign signaling links to the LIM cards using the `ent-slk` command.

Command example:

```
ent-  
slk:l2tset=1:link=a:loc=1105:lsn=ls400001:slc=0:e1port=1:ts=1
```

```
ent-  
slk:l2tset=1:link=a:loc=1106:lsn=ls500001:slc=0:e1port=1:ts=1
```

where:

:l2tset

Level 2 timer set. A signaling link can be assigned to any of the thirty timer sets.

:link

Signaling link assigned on the card specified in the `loc` parameter

:loc

Card location to which the signaling link is assigned

:lsn

Unique linkset name

:slc

Signaling link code. The `slc` must be unique within the linkset, and must be the same at both the system location and the distant node.

e1port

Port for E1 interface on the E1 card to which the signaling link and timeslot are being assigned

ts

E1 timeslot for the assigned signaling link

Signaling links are the only elements in the database supported directly by a hardware device. When a link is added to a linkset, the link remains in Out-of-Service-Maintenance-Disabled (**OOS-MT-DSBLD**) state until it is activated; see [23](#).

16. Verify the changes using the `rtrv-slk` command, specifying the card location and ID of the signaling link entered in [15](#).

Command examples:

```
rtrv-slk:loc=1105:link=a
```

```
rtrv-slk:loc=1106:link=a
```

17. Add a route for the new **DPC** by network type using the `ent-rte` command.

Command examples:

```
ent-rte:dpci=2-100-2:lsn=ls400001:rc=10
```

```
ent-rte:dpcn=21112:lsn=ls500001:rc=10
```

where:

:dpc/dpca/dpci/dpcn

Destination point code of the node to which the traffic is bound

:lsn

Linkset name associated with this route

:rc

Relative cost or priority of this route

18. Verify the changes using the `rtrv-rte` command and specifying the destination point code of the route.

19. Add a mated application by network type to the database using the `ent-map` command.

Command examples:

```
ent-
```

```
map:grp=grp03:materc=99:mpci=3-200-1:mssn=50:pci=2-100-1:ssn=12:rc=20
```

```
ent-
```

```
map:grp=grp07:materc=99:mpcn=11114:mssn=250:pcn=11112:ssn=12:rc=10
```

where:

:grp

Concerned point code broadcast list (CSPC) group name. This parameter specifies the name of a group of point codes that should be notified of the subsystem status. A different CSPC group can be assigned to each mated PC/SSN.

:materc

Mate relative cost

:mpc/mpca/mpci/mpcn

Mate remote point code.

:mssn

Mate subsystem number – the subsystem address of the backup point code that is to receive the message

:pci/pcn
ITU international/national point code

:rc
Relative cost

:ssn
Subsystem number – the subsystem address of the primary point code that is to receive the message

20. Verify the changes using the `rtrv-map` command.
21. Allow the LIM cards that were entered in 12 using the `alw-card` command.

Command examples:

```
alw-card:loc=1105
```

```
alw-card:loc=1106
```

This message appears:

```
tekelecstp51 09-08-24 21:16:37 GMT EAGLE 41.0.0
Card has been allowed.
```

22. Verify In-Service-Normal (**IS-NR**) state of the cards using the `rept-stat-card` command.
23. Activate the signaling links entered in 15 using the `act-slk` command.

Command examples:

```
act-slk:loc=1105:link=a
```

```
act-slk:loc=1106:link=a
```

The link changes state from Out-of-Service-Maintenance-Disabled (OOS-MT-DSBLD) to In-Service-Normal (IS-NR). The output confirms the activation.

```
tekelecstp51 09-08-24 21:16:37 GMT EAGLE 41.0.0
Activate Link message sent to card
```

24. Verify In-Service-Normal (IS-NR) state of the signaling link using the `rept-stat-slk` command.

Command examples:

```
rept-stat-slk:loc=1105
```

```
rept-stat-slk:loc=1106
```

25. Display the new LIM cards in the database using the `rtrv-card` command.

Example of a possible output:

```
tekelecstp51 09-08-24 21:16:37 GMT EAGLE 41.0.0
CARD  TYPE      APPL      LSET NAME      LINK SLC LSET NAME
LINK SLC
1105  LIME1        CCS7ITU    ls400001      A    00  -----
B    --
```

```
1106  LIME1  CCS7ITU  1s500001  A  00  -----
B    --
```

The HLR destinations are now configured and ready for G-Port feature activation.

4.5 G-Port Feature Activation Procedure

Use this procedure to enable, turn on, and configure the **GSM Mobile Number Portability (G-Port)** feature. Refer to *Commands User's Guide* for detailed descriptions of the commands that are used in this procedure.

Caution:

Before starting this procedure, contact [My Oracle Support](#) for assistance in performing the feature activation procedure. Do not proceed without consulting with Technical Services.

1. Enter the `enable-ctrl-feat` command to enable the G-Port feature:

```
enable-ctrl-feat:partnum=893017201:fak=<Feature Access Key>
```

2. Enter the `chg-ctrl-feat` command to turn on the G-Port feature:

```
chg-ctrl-feat:partnum=893017201:status=on
```

3. Enter the default country code and default network destination code to convert the nature of address indicator (NAI) of MSISDNs to the international format (`nai=intl`) with the `chg-stpopts` command.

Command example:

```
chg-stpopts:defcc=1:defndc=38:dsmad=on:npcfnti=2-9-2-1
```

where:

:defcc

Default country code

:defndc

Default network destination code

:dsmad

Service Module card checksum audit running state (*on* or *off*)

:npcfnti

ITU National Point Code Format Identifier, which identifies how the ITU national point code is entered into the database and how it is displayed in all EAGLE outputs. The ITU national point code is a 14-bit integer.

4. Verify the new country code and network destination code using the `rtv-stpopts` command.
5. Change the GSM system options in the database using the `chg-gsmopts` command.

Command example:

```
chg-
gsmopts: defmapvr=2:msrndig=ccrndn:srfaddr=23448:srfnai=7:srf
np=15
```

where:

:defmapvr

Default MAP version

:msrndig

Routing number to be used as is or to be concatenated with the **MSISDN**

:srfaddr

Entity address of the MNP_SRF node

:srfnai

Nature of address indicator value of the MNP_SRF

:srfnp

Numbering plan value of the MNP_SRF

6. Verify the changes using the `rtrv-gsmopts` command to display all GSM system options from the database.
7. Add routing number prefixes for the operating network using the `ent-homern` command. Add Home RNs that are prefixed to DNs for incoming INPMR messages. Up to 100 routing number prefixes for the operating network can be added to the HOMERN table.

Command example:

```
ent-homern:rn=34
```

where:

:rn

Home routing number prefix. Parameter value is 1 to 15 hex digits (0-F).

8. Verify the changes using the `rtrv-homern` command to retrieve a list of routing number prefixes that belong to the operating network.
9. Display the list of administered service selector combinations using the `rtrv-srvsel` command.

Avoid lengthy output by filtering the list using various parameter combinations. The service selector table can have over 1,000 entries.

10. Enter the G-Port service selectors by network type, if necessary, using the `ent-srvsel` command.

This command assigns applicable service selectors required to specify the service entry for Service Module card services.

Command example:

```
ent-
srvsel:gtii=4:nai=intl:np=e164:serv=gport:snai=intl:snp=e164:
ssn=9:tt=1
```

where:

:gtii
Global title indicator, ITU international

:nai
Nature of address indicator

:np
Numbering plan

:serv
Service feature

:snai
International **Service Nature of Address Indicator**

:snp
Service numbering plan

:ssn
Subsystem number

:tt
Translation type

11. Verify the changes using the `rtrv-srvsel` command to retrieve the list of administered service selector combinations.

Avoid lengthy output by filtering the list using various parameter combinations. The service selector table can have over 1,000 entries.

Command examples:

```
rtrv-srvsel:gtii=2
```

```
rtrv-srvsel:gtii=4
```

where:

gtii
Global title indicator, ITU international

 **Caution:**

GTT, EGTT, and VGTT traffic is routed based on the global titles in the **OAM** database while G-Flex, G-Port, A-Port, and INP traffic is routed based on the global title in the RTDB. Rebooting a Service Module card running the SCCPHC application causes both the OAM databases and the RTDB on the Service Module card to reload.

12. Verify that the Service Module card returns to In-Service-Normal (IS-NR) state using the `rept-stat-card` command.

 **warning:**

Do not proceed until In-Service-Normal (IS-NR) state of the Service Module card is restored.

13. After In-Service-Normal (IS-NR) state of the Service Module card is restored and verified using the `rept-stat-card` command, repeat 12 for each Service Module card in the system.
14. Set the G-Port service state online using `chg-sccp-serv:serv=gport:state=online`.
15. Confirm that the activation steps were successful by performing the following verifications:
 - Verify that all Service Module cards are loaded and are in In-Service-Normal (IS-NR) state using the `rept-stat-sccp` command.
 - Verify that all Service Module cards and the **EPAP** are connected and operational using the `rept-stat-mps` command.
 - Verify that database levels are identical for the EPAP **PDB** and **RTDB**. Display the RTDBs on the Service Module cards using `rept-stat-db:display=all`.

The GSM Mobile Number Portability (G-Port) feature is now enabled, turned on, and operating in the system.

4.6 MT-Based GSM SMS NP Feature Activation Procedure

This procedure is used to activate the MT-Based GSM SMS NP feature.

Before this feature can be enabled, the G-Port feature must be enabled.

Before the MT-Based GSM SMS NP feature can be turned on, the G-Port Feature must be turned on.

The MT-Based GSM SMS NP feature can be enabled before the G-Port feature is turned on.

For details about the commands used in this procedure, refer to *Commands User's Guide*.

1. Verify that the G-Port Feature is enabled using the `rtrv-ctrl-feat` command.
2. If the G-Port Feature is not enabled, enable it using [G-Port Feature Activation Procedure](#) before proceeding.
3. Enter the `enable-ctrl-feat` command to enable the MT-Based GSM SMS NP feature.

```
enable-ctrl-feat:partnum=893020001:fak=<Feature Access Key>
```

4. Enter the `chg-stpopts` command to set the default country code and, if desired, the default network destination code to convert the nature of address indicator (**NAI**) of **MDNs** to the international format (`nai=intl`).

The parameters in this command are used for number conditioning.

For example, enter this command:

```
chg-stpopts:defcc=49:defndc=177
```

where:

defcc

The default country code.

defndc

The default network destination code.

5. Verify the new country code and network destination code using the `rtrv-stpopts` command.
6. Enter the `rtrv-gsmopts` command to view the values of the GSMOPTS table options.
7. Change the value DefMCC in the GSMOPTS table using the `chg-gsmopts` command. If desired, other GSM system options may also be changed with this command.

 **Note:**

GSMOPTS:DefMCC must be set to a valid value before the MT-Based GSM SMS NP feature can be turned on.

For example, enter this command:

```
chg-gsmopts:defmcc=253
```

where:

defmcc

Specifies the E212 default mobile country code.

8. Verify the changes using the `rtrv-gsmopts` command.
This command displays GSM system options from the database.
9. Enter the `rtrv-gsmsmsopts` command to view the values of the GSMSMSOPTS table options.
10. If desired, change the GSM SMS options in the database for the MT-Based GSM SMS NP feature using the `chg-gsmsmsopts` command.

 **Note:**

MTSMSDLTRV must be set to a value other than "NONE" before MTSMSDLTR can be set to either PRERN or POSTRN. For details about all options that can be changed using the `chg-gsmsmsopts` command, refer to *Commands User's Guide*.

For example, enter this command:

```
chg-gsmsmsopts:mtsmsimsi=mccrndn:mtsmstype=rn
```

where:

mtsmsimsi

Specifies the format of the IMSI parameter of the SRI_SM ACK response.

mtsmstype

Indicates the entity type for which a database lookup is considered successful.

11. Verify the changes using the `rtrv-gsmsmsopts` command.

This command displays all GSM SMS options from the database.

12. If the value of `GSMSMSOPTS:MTSMSCHKSRC=YES`, then provision the home SMSC table entries using the `ent-home-smsc` command.

For example, enter this command:

```
ent-home-smsc:smc=552611646
```

13. Verify the SMSC table contents using the `rtrv-home-smsc` command.

This command retrieves the HOME SMSC specific addresses currently used to identify Short Message Service Centers in the database.

14. Verify that the G-Port Feature is turned on using the `rtrv-ctrl-feat` command.

15. If the G-Port Feature is not turned on, see [G-Port Feature Activation Procedure](#) before proceeding.

16. Enter the `chg-ctrl-feat` command to turn on the MT-Based GSM SMS NP feature.

```
chg-ctrl-feat:partnum=893020001:status=ON
```

The MT-Based GSM SMS NP feature is now enabled, turned on, and operating in the system.

4.7 MT-Based GSM MMS NP Feature Activation Procedure

This procedure is used to activate the MT-Based GSM MMS NP feature.

Before this feature can be enabled, the MT-Based GSM SMS NP feature must be enabled.

Before the MT-Based GSM MMS NP feature can be turned on, the MT-Based GSM SMS NP feature must be turned on.

The MT-Based GSM MMS NP feature can be enabled before the MT-Based GSM SMS NP feature is turned on.

For details about the commands used in this procedure, refer to *Commands User's Guide*.

1. Verify that the MT-Based GSM SMS NP feature is enabled using the `rtrv-ctrl-feat` command.
2. If the MT-Based GSM SMS NP feature is not enabled, enable it using [MT-Based GSM SMS NP Feature Activation Procedure](#) before proceeding.

3. Enter the `enable-ctrl-feat` command to enable the MT-Based GSM MMS NP feature.

```
enable-ctrl-feat:partnum=893024101:fak=<Feature Access Key>
```

4. Enter the `rtrv-gsmsmsopts` command to view the values of the `GSMSMSOPTS` table option.

5. If desired, MT-Based GSM MMS NP feature options may be changed with this command.

For example, enter this command:

```
chg-gsmsmsopts:mtmmsgta=12345:mtmmsackn=ack:mtmmstype=rn
```

where:

mtmmsgta

Specifies the GTA that is compared to the SCCP CgPA GTA of an SRI_SM message to determine whether the originator of the messages is a Home MMSC.

mtmmsackn

Specifies the message that is generated in response to a successful RTDB lookup for an SRI_SM message from a Home MMSC.

mtmmstype

Specifies the value of the entity type that indicates that a successful lookup occurred in the RTDB for messages that are modified by the MT-Based GSM MMS NP feature.

 **Note:**

For details about all of the options that can be changed using the `chg-gsmsmsopts` command, refer to *Commands User's Guide*.

6. Verify the changes using the `rtrv-gsmsmsopts` command.
This command displays the GSM SMS options from the database.
7. Verify that the MT-Based GSM SMS NP feature is turned on using the `rtrv-ctrl-feat` command.
8. If the MT-Based GSM SMS NP feature is not turned on, refer to [MT-Based GSM SMS NP Feature Activation Procedure](#) before proceeding.
9. Enter the `chg-ctrl-feat` command to turn on the MT-Based GSM MMS NP feature.

```
chg-ctrl-feat:partnum=893024101:status=ON
```

The MT-Based GSM MMS NP feature is now enabled, turned on, and operating in the system.

4.8 G-Port SRI Query for Prepaid Feature Activation Procedure

This procedure is used to activate the G-Port SRI Query for Prepaid feature.

Before this feature can be enabled, the G-Port feature must be enabled and turned on.

The G-Port SRI Query for Prepaid feature cannot be enabled with a Temporary Feature Access key (FAK).

The G-Port SRI Query for Prepaid feature cannot be turned off after the feature is turned on.

The Service Portability support for G-Port SRI Query for Prepaid feature cannot be enabled with a Temporary Feature Access key (FAK).

The Service Portability support for G-Port SRI Query for Prepaid feature can be turned off after it is turned on.

For details about the commands used in this procedure, refer to *Commands User's Guide*.

1. Verify that the G-Port Feature is enabled and turned on using the `rtrv-ctrl-feat` command.
2. If the G-Port Feature is not enabled and turned on, enable and turn on the G-Port feature using [G-Port Feature Activation Procedure](#) before proceeding.
3. Enter the `enable-ctrl-feat` command to enable the G-Port SRI Query for Prepaid feature.

```
enable-ctrl-feat:partnum=893017701:fak=<feature access key>
```

4. Enter the `ent-gserv-data` command to provision the translation type, originating point code, or global title address data in the GSERV table.

The `tt` parameter is used to specify a called party (CdPA) translation type, the `opc/opca/opci/opcn/opcn24` parameters are used to specify message transfer part (MTP) originating point codes, and the `gta` parameter is used to specify a calling party (CgPA) global title address. These values determine whether a Send Routing Information (**SRI**) request receives G-Port SRI Query for Prepaid service or normal G-Port service.

Command example:

```
ent-gserv-data:tt=77
```

where:

tt

Translation type

5. Verify the new values of the GSERV table using the `rtrv-gserv-data` command.
6. Provision the default routing number in the GSMOPTS table using the `chg-gsmopts` command, if required. The default routing number is used to determine the digits to use as the routing number portion of the `msrndig` parameter.

Command example:

```
chg-gsmopts:dfltrn=135
```

where:

dfltrn

Default routing number

7. Enable Service Portability if Service Portability support for G-Port SRI Query for Prepaid feature is required. If Service Portability support for G-Port SRI Query for Prepaid feature is not required, continue to [10](#).

Command example:

```
enable-ctrl-feat:partnum=893034301:fak=<feature access key>
```

8. Provision the Service Portability Type in the GSMOPTS table using the `chg-gsmopts` command.

Command example:

```
chg-gsmopts:sporttype=all
```

where:

sporttype

Service Portability Type

9. Turn on the Service Portability feature using the `chg-ctrl-feat` command.

Command example:

```
chg-ctrl-feat:partnum=893034301:status=ON
```

10. Turn on the G-Port SRI Query for Prepaid feature using the `chg-ctrl-feat` command.

Command example:

```
chg-ctrl-feat:partnum=893017701:status=ON
```

The G-Port SRI Query for Prepaid feature is now enabled, turned on, and operating in the system. SRI messages received for G-Port SRI Query for Prepaid will receive Service Portability processing only if the optional Service Portability feature is enabled and turned on.

4.9 GSM MAP SRI Redirect to Serving HLR Feature Activation Procedure

This procedure is used to activate the GSM MAP SRI Redirect to Serving HLR feature.

Before this feature can be enabled, the G-Port feature must be enabled and turned on.

The GSM MAP SRI Redirect to Serving HLR feature cannot be enabled with a Temporary Feature Access Key.

The GSM MAP SRI Redirect to Serving HLR feature cannot be turned off after the feature is turned on.

For details about the commands used in this procedure, see *Commands User's Guide*.

1. Verify that the G-Port Feature is enabled and turned on using the `rtrv-ctrl-feat` command.
2. If the G-Port Feature is not enabled and turned on, enable and turn on the G-Port feature using [G-Port Feature Activation Procedure](#) before proceeding.
3. Enter the `enable-ctrl-feat` command to enable the GSM MAP SRI Redirect to Serving HLR feature.

```
enable-ctrl-feat:partnum=893014001:fak=<Feature Access Key>
```
4. Enter the `chg-prefix-feat` command to relate the GSM MAP SRI Redirect to Serving HLR feature to vendor prefix values, and to specify the prefix numbers that associate to entries in the Vendor ID List. A maximum of 128 prefix values can be entered in the Vendor Prefix Table for the GSM MAP SRI Redirect to Serving HLR feature.

Command examples:

```
chg-prefix:feature="gsm map sri
redirect"prefixnum=1:prefix=1004
```

```
chg-prefix:feature="gsm map sri
redirect"prefixnum=2:prefix=1003
```

```
chg-prefix:feature="gsm map sri
redirect"prefixnum=3:prefix=1004
```

where:

feature

Feature Name.

prefixnum

Prefix Number. GSM MAP SRI Redirect to Serving HLR feature uses 1 - 128.

prefix

Prefix Value.

5. Verify the Vendor Prefix Table entries using the `rtrv-prefix` command.
6. Enter Vendor ID Length for the Vendor ID List using the `ent-vendid` command.

Command example:

```
ent-vendid:vendidlen=6
```

where:

vendidlen

Vendor ID Length. All Vendor IDs defined for the GSM MAP SRI Redirect to Serving HLR feature must contain this number of digits.

7. Enter the Vendor IDs and Vendor Numbers using the `ent-vendid` command.

Command example:

```
ent-vendid:vendid=886932:vendnum=1:vendtype=1
```

```
ent-vendid:vendid=886936:vendnum=1:vendtype=1
```

```
ent-vendid:vendid=886935:vendnum=2:vendtype=2
```

```
ent-vendid:vendid=886938:vendnum=3:vendtype=1
```

where:

vendid

Vendor ID.

vendnum

Vendor Number, used as a reference to the Vendor prefix.

vendtype

Vendor Type.

8. Verify that all G-Port provisioning information is specified: service selector, HomeRN deletions, default GTT, and GSMOPTS values.
9. Enter the `chg-ctrl-feat` command to turn on the GSM MAP SRI Redirect to Serving HLR feature.

```
chg-ctrl-feat:partnum=893014001:status=ON
```

The GSM MAP SRI Redirect to Serving HLR feature is now enabled, turned on, and operating in the system.

5

Measurements

This chapter describes the measurements information available from the EAGLE for the G-Port feature.

5.1 G-Port Measurements

Refer to *Measurements Reference* for information about measurement systems and reporting.

Refer to *Commands User's Guide* for descriptions of commands used to generate, schedule, and transfer measurements reports.

Refer to *Database Administration - System Management User's Guide* for provisioning information and procedures for these measurement systems:

- OAM-based Measurements - G-Port measurements are available using the File Transfer Area (FTA) feature and not directly by EAGLE terminals.
- Measurements Platform
- E5-OAM Integrated Measurements

[Table 5-1](#) describes the peg counts of Message Signalling Units (MSUs) supported per-system for the G-Port feature.

Table 5-1 Pegs for Per System G-Port Measurements

Event Name	Description	Type	Unit
GPSRRCV	Number of call-related SRI messages received. Peg counts for register GPSRRCVPP are not included in this register.	System	Peg count
GPSRGTT	Number of call-related SRI messages that fell through to GTT . Peg counts for register GPSRGTTTPP are not included in this register.	System	Peg count
GPSRREP	Number of call-related SRI messages that received G-Port service. Peg counts for register GPSRREPPP are not included in this register.	System	Peg count
GPSRERR	Number of call-related messages that cause SRI negative ack messages because of G-Port service failure. Peg counts for register GPSRERRPP are not included in this register.	System	Peg count

[Table 5-2](#) describes the peg counts of Message Signalling Units (MSUs) supported per-SSP for the G-Port feature.

Table 5-2 Pegs for Per SSP G-Port Measurements

Event Name	Description	Type	Unit
GPSRACK	Number of call-related SRI ack messages. Peg counts for register GPSRACKPP are not included in this register.	Point Code	Peg count
GPSRNACK	Number of call-related SRI negative ack messages in successful G-Port service	Point Code	Peg count
GPSRRLY	Number of call-related SRI messages relayed	Point Code	Peg count

Table 5-3 describes the peg counts of Message Signalling Units (MSUs) supported both per-system and per-SSP for the G-Port feature.

Table 5-3 Pegs for Per System and Per SSP G-Port Measurements

Event Name	Description	Type	Unit
GPNOCCL	Number of non-call-related messages relayed by G-Port	System, Point Code	Peg count
GPNOCCLGT	Number of non-call-related messages that fell through to GTT	System, Point Code	Peg count
GPSRSMREP	Number of SRI_SM messages that result in SRI_SM_ACK or SRI_SM_NACK responses	System, Point Code	Peg count
GPSRSMERR	Number of SRI_SM messages that result in error	System, Point Code	Peg count
GPSRSMRCV	Number of SRI_SM messages received	System, Point Code	Peg Count
MNPCRCD	Number of times Circular Route is detected	System, Point Code	Peg Count

Table 5-4 describes the peg counts of Message Signalling Units (MSUs) supported for the G-Port SRI Query for Prepaid feature.

Table 5-4 Pegs for G-Port SRI Query for Prepaid Measurements

Event Name	Description	Type	Unit
GPSRACKPP	Number of call-related SRI ack messages for G-Port SRI Query for Prepaid feature. Peg counts for register GPSRACK are not included in this register.	Point Code	Peg Count
GPSRGTTTPP	Number of call-related SRI messages that fell through to GTT for G-Port SRI Query for Prepaid feature. Peg counts for register GPSRGTT are not included in this register.	System	Peg Count
GPSRRCVPP	Number of call-related SRI messages received for G-Port SRI Query for Prepaid feature. Peg counts for register GPSRRCV are not included in this register.	System	Peg Count

Table 5-4 (Cont.) Pegs for G-Port SRI Query for Prepaid Measurements

Event Name	Description	Type	Unit
GPSRERRPP	Number of call-related messages that cause SRI negative ack messages for G-Port SRI Query for Prepaid feature. Peg counts for register GPSRERR are not included in this register.	System	Peg Count
GPSRREPPP	Number of call-related SRI messages that received G-Port service for G-Port SRI Query for Prepaid feature. Peg counts for register GPSRREP are not included in this register.	System	Peg Count

The following equations apply:

$$\text{GPSRRCV} = \text{GPSRGTT} + \text{GPSRREP} + \text{GPSRERR}$$

$$\text{GPSRCVPP} = \text{GPSRGTTTP} + \text{GPSRREPPP} + \text{GPSRERRPP}$$

$$\text{GPSRREP} = \sum \text{GPSRACK} + \sum \text{GPSRRLY} + \sum \text{GPSRNACK}$$

The following measurement events are included on the STP Daily Maintenance (MTCD) and STP Day-to-Hour (MTCDTH) measurement reports and include peg counts for G-Port MSUs.

MSSCCPFL

MSUs discarded due to SCCP routing failure.

GTTUN0NS

GTT unable to perform; no such type

GTTUN1NT

GTT unable to perform: no translation on this address

GTTPERFD

Total number of GTT performed

This implementation does not discriminate between the MSSCCPFL, GTTUN0NS, GTTUN1NT, or GTTPERFD pegs for G-Port or GTT applications. For example, a search failure could result from a problem in either the G-Port or GTT database.

6

Maintenance

This chapter describes the maintenance information available from the EAGLE for the G-Port feature. The information includes status, alarms (UAMs), and information messages (UIMs).

6.1 G-Port Related Alarms

Refer to *Unsolicited Alarm and Information Messages Reference* for a complete description and the associated corrective procedure for all EAGLE-related alarms (UAMs). Refer to *Alarms and Maintenance Guide* for EPAP for the descriptions and corrective procedures for MPS-related alarms.

G-Port Subsystem Alarms

The same alarms that are output for an **SCCP** subsystem are output for the **G-Port** functions, including G-Port traffic.

Table 6-1 G-Port Subsystem Alarms

UAM #	Severity	Message Text	Output Group (UI Output Direction)
0328	None	SCCP is available	gtt
0329	None	SCCP capacity normal, card(s) abnormal	gtt
0330	Major	SCCP TPS Threshold exceeded	gtt
0331	Critical	SCCP is not available	gtt
0335	None	SCCP is removed	gtt
0336	Major	LIM(s) have been denied SCCP service	gtt
0526*	None	Service is available	sys_maint
0527*	Minor	Service abnormal	sys_maint
0528*	Critical	Service is not available	sys_maint
0529*	Critical	Service is disabled	sys_maint
0530*	None	Service is removed	sys_maint

*GPORT is displayed in the text of the message if the G-Port feature is enabled without the additional features of A-Port or IGM being enabled. If the A-Port and/or IGM features are enabled, the text GPORT will be replaced with the text MNP.

6.2 G-Port Related UIMs

G-Port UIM formats for the **EGTT** feature support **GTT** requirements.

Unsolicited Alarm and Information Messages Reference contains a complete description of all UIM text and formats. [Table 6-2](#) lists UIMs used to support the G-Port feature.

Table 6-2 G-Port UIMs

UIM	Text	Description	Action
1035	SCCP rsp did not route - invalid GTI .	The SCCP response did not route due to an invalid GTI.	Use a valid GTI in the CGPA part of the query.
1036	SCCP rsp did not route - invalid TT.	The SCCP response did not route due to an invalid TT.	Provision the CGPATT in the GTT TT table.
1037	SCCP rsp did not route - bad Xlation	The SCCP response did not route due to a bad translation	Provision the CGPAGTA address in the GTT database.
1038	SCCP rsp did not route - SSP not True PC .	The SCCP response did not route because SSP is not true point code.	Use the true point code in the CGPA point code or OPC of the query.
1039	SCCP rsp did not route - bad Selectors	The SCCP response did not route due to invalid selectors.	Provision the CGPAGTI, TT, NP, and NAI in the EGTT selector table.
1169	SCCP rcvd inv TCAP portion	This indicates that SCCP discarded a message because the TCAP provided in the called party address is invalid in the EAGLE.	No action is necessary.
1227	SCCP did not route - DPC not in MAP tbl	This message indicates that SCCP did not route a message because the destination point code was not in the mated application (MAP) table. The message was discarded.	If the DPC indicated in the message should not be routed to, no further action is necessary.
1230	SCCP did not route - SS not in MAP tbl	This message indicates that SCCP did not route a message because the destination subsystem was not in the Mated Application (MAP) table. The message was discarded.	No action is necessary.
1242	Conv to intl num - Dflt CC not found	Conversion to international number failed because default CC was not found.	Define the default CC with chg- stpopts :defcc=xxx .
1243	Conv to intl num - Dflt NC not found	Conversion to international number failed because default NC was not found.	Define the default NDC with chg- stpopts :defndc=xx xxx.
1246	Invalid length of conditioned digits	Length of conditioned international number is less than 5 or greater than 15 (invalid length of conditioned digits).	Use an international number with length in the acceptable range.
1256	MNP Circular Route Detected	This message indicates the network has incorrect number portability data for a subscriber.	Verify and update number portability data.

Table 6-2 (Cont.) G-Port UIMs

UIM	Text	Description	Action
1294	Invalid digits in MAPMSISDN parameter	No digits are found in MAP MSISDN parameter.	Specify valid digits in the MSISDN.
1295	Translation PC is EAGLE's	PC translation is invalid because it is one of EAGLE PCs.	Change the point code.
1296	Translation PC type is ANSI	PC translation is invalid because it is an ANSI point code.	Change the point code.
1297	Invalid length of prefix/suffix digits	Attempted digit action of prefixing entity ID is invalid because combined length of entity ID and GT digits was greater than 21 digits.	Change the attempted digit action or decrease the length of the entity ID and/or GT digits.
1374	SMS NP destination address decode failed	An error was detected during decode of SMS message destination address.	The message should be analyzed to determine the error, and the originating node should be contacted to send corrected message.
1375	SMS NP failed to modify TCAP message	The formatted outbound digit string length generated by SMS NP for encoding the TCAP message exceeded system limits.	The message and outbound digits formatting options should be analyzed to determine the error and the originating node or the requested outbound digit formatting option should be modified to correct the encoding error.
1376	SMS NP outbound digits leng exceed limit	During processing of SMS message, the formatted outbound digit string length exceeded limit for number of digits.	The message and the digit format provisioning should be analyzed to determine the error and the originating node or the requested outbound digit formatting option should be modified to correct the encoding error.
1426	S-Port: Missing GRN for srvc prtd subs	Service Portability is to be applied; GRN is required, but is not provisioned for the DN.	Provision the GRN for the DN.

6.3 Maintenance Commands

The following commands can be used for maintenance when an EPAP-related feature is on.

Refer to *Commands User's Guide* for complete descriptions of the commands, including parameters, valid parameter values, rules for using the commands, and output examples.

Table 6-3 Maintenance Commands

Command	Description
rept-stat-sys	Reports the status of system entities, including cards. The output includes the number of Service Module cards that are in service (IS-NR) and how many are in another state (IS-ANR, OOS-MT, OOS-MT-DSBLD).
rept-stat-sccp	Reports operating status of services and subsystems, CPU usage, and Service Module card status. When the <code>loc</code> parameter is specified, the command displays detailed card traffic statistics, including cards that are denied SCCP service. See the section in this manual that describes the use of the <code>rept-stat-sccp</code> command.
rept-stat-mps	Displays the overall status of the EPAP application running on the MPS (multi-purpose server). Command output for the various reports of this command include overall MPS alarm status and card status, and status for a specific Service Module card when a feature is on.
rept-stat-trbl	Includes a summary of any trouble notifications (UAMs) for local subsystems, cards, and linksets. The severity of each alarm is indicated in the output report.
rept-stat-alm	Displays the alarm counts and totals for local subsystems and Service Module card/EPAP IP links.
rept-stat-db	Displays the status information for the EAGLE databases. This includes the level information for each Service Module card, and for the active and standby EPAP RTDB. The command reports database exception status such as corrupted, incoherent, or inconsistent, as well as providing the birth dates and levels. It shows the status of each PDB and RTDB when an EPAP-related feature is enabled.
rtrv-tbl capacity	Retrieves table use capacity summary information. For each table listed, the number of table entry elements in use and the total allowed number of table elements is presented, along with a percent (%) full value. Information is shown for some tables only if the feature that uses the table is enabled.
inh-card/alw-card	The <code>inh-card</code> command is used to change the operating state of the card from In-Service Normal (IS-NR) to Out-of-Service Maintenance-Disabled (OOS-MT-DSBLD). A craftsman then can test the card or physically remove it from the shelf. The <code>alw-card</code> command is used to change the card from OOS-MT-DSBLD (Out-of-Service Maintenance-Disabled) to IS-NR (In-Service Normal) if card loading is successful.
inh-alm/unhb-alm	Used to allow and inhibit reporting of alarms for a given device, including the Service Module card ports. The commands allow both Port A and Port B to be specified. Inhibited alarms will not generate UAMs or cause alarm indicators to be turned on. All <code>rept-stat-xxx</code> commands continue to display the alarms with an indication that the device has its alarms inhibited.
rtrv-data-rtdb	Retrieves Entity data, DN data, IMEI data, IMSI data, TN data, NPANXX data, and LRN data from the RTDB on an active Service Module card. If the <code>loc</code> parameter is specified and the target card is an active Service Module card, the RTDB data is retrieved from that card. If the <code>loc</code> parameter is not specified, the RTDB data is retrieved on the active Service Module card that has the lowest IMT address. The RTDB status on the active Service Module card can be coherent or incoherent.

6.3.1 rept-stat-sccp

The `rept-stat-sccp` command provides statistics for Service Module cards and for the services that execute on the cards. The statistics can be displayed for all Service Module cards or for a specified card.

Refer to *Commands User's Guide* for a description of the `rept-stat-sccp` command, including parameter names, valid parameter values, rules for using the command, and output examples.

The `rept-stat-sccp` command reports current **MNP** statistics. An MSU is considered to be a G-Port MSU after service selection.

6.4 Debug Commands

Commands User's Guide contains descriptions of debug commands that can be used in assessing and modifying system status and operation. Most debug commands are used only under the direction of Oracle support personnel. Refer to *Commands User's Guide* for a complete description of the debug commands, including the `ent-trace` command.

G-Port uses the `ent-trace` command to provide a trap-and-trace function for **MSUs** on the Service Module cards. G-Port also includes a trigger so that the user can trigger on **DN** and **IMSI**.

The user can create an MSU trigger on the Service Module card on one or more criteria (both old and new) defined in the following using the `ent-trace` command. When multiple trigger criteria are entered, the MSU is trapped when any one of the criteria is satisfied.

▲ Caution:

As with other debug commands, the `ent-trace` command can cause **OAM** to reset if too many MSUs are trapped.

- **RN or SP address (Entity ID)** - Use this new criterion to trap messages immediately after performing the **RTDB** lookup. If the RN or SP obtained from the database lookup matches the Entity ID provisioned in the command, the message is trapped. This parameter supports a variable number of hexadecimal digits from 1 to 15 digits, and the Entity ID specified must be the one stored in the RTDB.
- **E.164 MSISDN number (DN)** – Use this criterion to trap messages immediately before performing a G-Port search based on the MSISDN numbers defined in the RTDB. This parameter accepts a range of digits, from 5 to 15. The number specified must be an International E.164 number (MSISDN or Entity Number).
- **Global Title digits (GT)** – Use this criterion to trap messages based on **CdPA** Global Title Address (either MSISDN (+**ST**) number or RN + MSISDN (+**ST**)) present in the **SCCP** part of the message.
- **Origination point code SSPI/SSPN)** – Use this criterion to trap messages based on **CgPASPC** present in the SCCP part of the message. If no point code is

present in the CgPA SPC, the criteria is matched with the **OPC** present in the **MTP** part of the message.

A trace must be set on all Service Module cards; specify `card=sccp-all`. Use a repetition parameter (`rep`) to control the number of MSUs that are trapped.

MSUs that satisfy any trigger criteria are trapped on the Service Module cards, are forwarded to OAM, and are displayed. Refer to *Commands User's Guide* for a complete description of the `ent-trace` command, including parameters, valid parameter values, rules for using the command, and output examples.

6.5 Status Reporting and Problem Identification

EAGLE commands can be used to obtain status and statistics for the EAGLE system, the EPAP systems, system devices including Service Module cards, EPAP-related features, local subsystems, and SCCP services.

Refer to *Commands User's Guide* for complete descriptions of the commands, including parameters and valid values, rules for using the commands correctly, and output examples.

Refer to *Unsolicited Alarm and Information Messages Reference* for descriptions and recovery procedures for UAMs and UIMs.

Refer to *Administration Guide* for EPAP for descriptions of EPAP functions and operation.

Refer to *Alarms and Maintenance Guide* for descriptions and recovery procedures for EPAP alarms.

Refer to the appropriate feature User's Guide for information about the functions and operation of EPAP-related features.

Table 6-4 Status Reporting for EPAP-Related Features

Reports, Status, and Statistics	Command
EAGLE	
Maintenance Status Report - indicates whether Maintenance, Routing, and SCCP Baselines have been established.	<code>rept-stat-sys</code>
Alarms and operating state for system devices, including Service Module ("SCCP") cards.	<code>rept-stat-sys</code>
Unsolicited Alarm Messages (UAMs) and Unsolicited Information Messages (UIMs)	<code>rept-stat-alm</code> <code>rept-stat-trbl</code>
EPAP/MPS (from the EAGLE)	
EPAP code version and operating state for each EPAP.	<code>rept-stat-mps</code>
MPS hexadecimal alarm strings for the active and standby EPAPs.	<code>rept-stat-mps</code>
Operating state and alarm status of equipped Service Module cards and their DSM ports and IP connections.	<code>rept-stat-mps</code> <code>rept-stat-mps:loc=<Service Module card location></code>

Table 6-4 (Cont.) Status Reporting for EPAP-Related Features

Reports, Status, and Statistics	Command
Amount of memory used by the RTDB on the specified card, as a percent of available Service Module card memory.	<code>rept-stat-mps:loc=<Service Module card location></code>
EPAP Provisioning Database (PDB), EPAP Real Time Database (RTDB), and Service Module card RTDB status information - Coherent, birthdate (date and time of creation), and exception (condition when a problem was detected).	<code>rept-stat-db</code> <code>rept-stat-db:db=mps</code>
Service Module Cards, EPAP-Related Features, Services, Local Subsystems	
Status of the Service Module cards, and the services executing on the cards for EPAP-related features that are turned on. Includes Service Report, Subsystem Report, and Alarm Status; Total Service Statistics.	<code>rept-stat-sccp</code>
Operating state and alarm status of equipped Service Module cards and their DSM ports and IP connections; EPAP-related feature status per card.	<code>rept-stat-mps:loc=<Service Module card location></code>
Alarms and operating state for Service Module ("SCCP") cards.	<code>rept-stat-sys</code> <code>rept-stat-mps</code>
Any cards that are denied SCCP service.	<code>rept-stat-sccp</code>
Detailed view of the status of SCCP services provided by the specified Service Module card. Includes Card Alarm Status, Card Service Statistics	<code>rept-stat-sccp:loc=<Service Module card location></code>
General SCCP traffic performance for Service Module cards. Message rates for TVG performance.	<code>rept-stat-sccp:mode=perf</code>
Statistics for EPAP-related feature local subsystems - Subsystem Report	<code>rept-stat-sccp</code>
Statistics for EPAP-related features	<code>rept-stat-sccp</code>

6.5.1 EPAP Status and Alarm Reporting

Because EPAP has no direct means of accepting user input or displaying output messages on EAGLE terminals, EPAP maintenance, measurements, and status information are routed through a Service Module card. EPAP sends two types of messages to the Service Module card: [EPAP Maintenance Blocks](#) and [DSM Status Requests and DSM Status Messages](#). Each message type is discussed in the following sections.

EPAP Maintenance Blocks

The EPAP forwards all status and error messages to the Service Module cards in maintenance blocks. Maintenance blocks are asynchronously sent whenever the EPAP has something to report. The status information that is displayed when a `rept-`

`stat-mps` command is issued includes information that came from the maintenance blocks.

The active EPAP generates and sends maintenance blocks to the primary Service Module card. One maintenance block is sent as soon as the IP link is established between the active EPAP and the primary Service Module card. Additional maintenance blocks are sent whenever the EPAP needs to report any change in status or error conditions. The information returned in maintenance blocks is included in the output of the `rept-stat-mps` and `rept-stat-sccp` commands.

The EPAP sends maintenance blocks that contain at least the following information:

- Status of EPAP A - actual states are active, standby, and down (inoperative). Maintenance blocks include a field for this information so that it can be available for the output of the `rept-stat-mps` command.
- Status of EPAP B - actual states are active, standby, and down (inoperative). Maintenance blocks include a field for this information so that it can be available for the output of the `rept-stat-mps` command.
- Identification of Active EPAP - a field to identify the active EPAP.
- Congestion Indicator - an indicator showing provisioning link congestion. The link between the EPAPs and the external source of provisioning data can become congested in high-provisioning traffic situations. When this occurs and subsequently as the congestion clears, the EPAP sends maintenance blocks to the Service Module card.
- Alarm Conditions - an error code field. If the EPAP needs to report an alarm condition, it puts an appropriate UAM identifier in this field.
- Current MPS Database Size - a field indicating the current RTDB size. The Service Module card uses this information to calculate the percentage of memory used by the RTDB.

DSM Status Requests and DSM Status Messages

When the EPAP needs to know the status of a Service Module card, the EPAP sends a DSM Status Request to all Service Module cards, and each Service Module card returns its status to the EPAP.

Service Module cards send a DSM Status Message to the EPAP when any the following events occur in the Service Module card:

- The Service Module card is booted.
- The Service Module card receives a DSM Status Request message from the EPAP.
- The Service Module card determines that it needs to download the entire RTDB; for example, the Service Module card determines that the RTDB needs to be downloaded because it is totally corrupted, or a user requests that the RTDB be reloaded. The Service Module card sends a Full Download Request message to the EPAP
- The Service Module card starts receiving RTDB downloads or updates. When a Service Module card starts downloading the RTDB or accepting updates, the Service Module card sends a DSM Status Message informing the EPAP of the first record received. This helps the EPAP keep track of downloads in progress.

The DSM Status Message provides the following information to the EPAP:

- **DSM Memory Size.** When the Service Module card is initialized, it determines the amount of memory present. The EPAP uses the value to determine if the Service Module card has enough memory to hold the RTDB.
- **Load Mode Status.** This indicator indicates whether or not a sufficient number of the IS-NR (In-Service Normal) LIMs have access to SCCP services.

6.5.2 Hourly Maintenance Report

The Hourly Maintenance Report, generated automatically, includes the alarm totals of the INP/AINPQ subsystem and **Service Module card /EPAP IP** links. A sample follows.

```
eagle10506 99-10-10 16:00:01 EST EAGLE 41.0.0
5072.0000 REPT COND GSM SS
"GSM SS :0440,MTCEINT-0,SA,99-10-10,16:00:01,,,,*C"
;
eagle10506 99-10-10 16:00:01 EST EAGLE 41.0.0
5073.0000 REPT COND INP SS
"INP SS :0440,MTCEINT-0,SA,99-10-10,16:20:01,,,,*C"
;
eagle10506 99-10-10 16:00:01 EST EAGLE 41.0.0
5077.0000 REPT COND EPAPDSM
"EPAPDSM :0084,MTCEINT-0,SA,99-10-10,16:00:01,,,,**"
;
eagle10506 99-10-10 16:00:01 EST EAGLE 41.0.0
5007.0000 REPT COND CARD
"CARD 1102:0422,SCMMA,SA,99-10-10,16:00:01,,,,**"
;
eagle10506 99-09-13 16:00:01 EST EAGLE 41.0.0
3561.0000 REPT COND ALARM STATUS
"ALARMS:PERM. INHIBITED,0,0,0"
"ALARMS:TEMP. INHIBITED,0,0,0"
"ALARMS:ACTIVE,10,14,3"
"ALARMS:TOTAL,10,14,3"
;
```

Index

C

call-related message, [2-25](#)
call-related SRI messages, [2-25](#)
chg-stpopts, [4-13](#)

D

decimal digit, [2-26](#)
dialed number length, [2-5](#)

E

E.164 number, [2-26](#)
ent-gserv-data, [4-17](#)
ETSI GSM 03.03, [2-5](#)

G

G-Port
 considerations, [2-26](#)
GDB requirements, [2-28](#)
GMSCA, [2-21](#)
GSERV table, [4-17](#)
GSM 03.66, [2-27](#)
GSM 09.02, [2-27](#)
GTT selectors, [2-28](#)

H

Hex Digit Support for GTT, [2-26](#)
hexadecimal digit, [2-26](#)
HLR translation, [2-25](#)
HLRB, [2-19](#), [2-22](#)

I

IAM message, [2-19](#), [2-20](#)
IMSI, [2-25](#)
INE, [2-22](#), [2-23](#)
international number, [2-18](#)
Interrogating Network Entity, [2-22](#), [2-23](#)

M

Message Relay GT address, [2-23](#), [2-24](#)
Message Relay message, [2-26](#)
MNP-SRF, [2-19](#), [2-25](#)
MNP-SRFA, [2-23](#)
MNP-SRFB, [2-22](#)
mobile subscriber, [2-25](#)
MSISDN, [2-19](#)

N

non-call-related message, [2-25](#)
non-ported case, [2-24](#)

O

Optimal Routing, [2-23](#)
original number range owner network, [2-19](#)

P

PLMN, [2-25](#)
portability cluster, [2-25](#)
ported case, [2-24](#)
ported numbers, [2-5](#)
ported subscriber, [2-25](#)
porting process, [2-25](#)
Public Land Mobile Network, [2-25](#)

R

recipient network, [2-25](#)
rept-stat-slk, [4-9](#)
RN prefix, [2-27](#)
roaming number, [2-20](#)
Routing Number, [2-19](#)
rtv-gserv-data, [4-17](#)
rtv-slk, [4-7](#)
rtv-stpopts, [4-14](#)

S

SRI-MNP message, [2-27](#)

subscription network, [2-19](#)

V

VMSCA, [2-21](#)