

Oracle® Communications Offline Mediation Controller Cartridge Packs



Release 15.2

G39984-01

January 2026

The Oracle logo, consisting of a solid red square with the word "ORACLE" in white, uppercase, sans-serif font centered within it.

ORACLE®

Oracle Communications Offline Mediation Controller Cartridge Packs, Release 15.2

G39984-01

Copyright © 2023, 2026, Oracle and/or its affiliates.

This software and related documentation are provided under a license agreement containing restrictions on use and disclosure and are protected by intellectual property laws. Except as expressly permitted in your license agreement or allowed by law, you may not use, copy, reproduce, translate, broadcast, modify, license, transmit, distribute, exhibit, perform, publish, or display any part, in any form, or by any means. Reverse engineering, disassembly, or decompilation of this software, unless required by law for interoperability, is prohibited.

The information contained herein is subject to change without notice and is not warranted to be error-free. If you find any errors, please report them to us in writing.

If this is software, software documentation, data (as defined in the Federal Acquisition Regulation), or related documentation that is delivered to the U.S. Government or anyone licensing it on behalf of the U.S. Government, then the following notice is applicable:

U.S. GOVERNMENT END USERS: Oracle programs (including any operating system, integrated software, any programs embedded, installed, or activated on delivered hardware, and modifications of such programs) and Oracle computer documentation or other Oracle data delivered to or accessed by U.S. Government end users are "commercial computer software," "commercial computer software documentation," or "limited rights data" pursuant to the applicable Federal Acquisition Regulation and agency-specific supplemental regulations. As such, the use, reproduction, duplication, release, display, disclosure, modification, preparation of derivative works, and/or adaptation of i) Oracle programs (including any operating system, integrated software, any programs embedded, installed, or activated on delivered hardware, and modifications of such programs), ii) Oracle computer documentation and/or iii) other Oracle data, is subject to the rights and limitations specified in the license contained in the applicable contract. The terms governing the U.S. Government's use of Oracle cloud services are defined by the applicable contract for such services. No other rights are granted to the U.S. Government.

This software or hardware is developed for general use in a variety of information management applications. It is not developed or intended for use in any inherently dangerous applications, including applications that may create a risk of personal injury. If you use this software or hardware in dangerous applications, then you shall be responsible to take all appropriate fail-safe, backup, redundancy, and other measures to ensure its safe use. Oracle Corporation and its affiliates disclaim any liability for any damages caused by use of this software or hardware in dangerous applications.

Oracle®, Java, MySQL, and NetSuite are registered trademarks of Oracle and/or its affiliates. Other names may be trademarks of their respective owners.

Intel and Intel Inside are trademarks or registered trademarks of Intel Corporation. All SPARC trademarks are used under license and are trademarks or registered trademarks of SPARC International, Inc. AMD, Epyc, and the AMD logo are trademarks or registered trademarks of Advanced Micro Devices. UNIX is a registered trademark of The Open Group.

This software or hardware and documentation may provide access to or information about content, products, and services from third parties. Oracle Corporation and its affiliates are not responsible for and expressly disclaim all warranties of any kind with respect to third-party content, products, and services unless otherwise set forth in an applicable agreement between you and Oracle. Oracle Corporation and its affiliates will not be responsible for any loss, costs, or damages incurred due to your access to or use of third-party content, products, or services, except as set forth in an applicable agreement between you and Oracle.

Contents

About This Content

1 About Cartridge Packs

About Cartridge Packs	1
-----------------------	---

2 Installing Cartridge Packs

Software Requirements	1
Installing Cartridge Packs	1
Uninstalling a Cartridge Pack	1
Removing Scripts From the Database	2
List of Cartridge Packs and JAR Files	3

3 AMA CDK Cartridge Pack

About the AMA CDK Cartridge Pack	1
Using the AMA CDK Cartridge for CDMA Services	1
Maintaining the Fixed Block Size	2
XML Schema	2

4 Elastic Charging Engine Cartridge Pack

About the ECE Cartridge Pack	1
Integrating ECE and Offline Mediation Controller	1
Integrating When Offline Mediation Controller and ECE are on the Same System	2
Integrating When ECE and Offline Mediation Controller are on Different Systems	2
Configuring the ECE DC Node	3
Editing the ECE DC Rule File	5
Configuration Block	5
Input Record Block	7
Output Record Block	8
Expose Block for PAYLOAD	9
Expose Block for Payload Data Type	9

Expose Block for Usage Object	9
Mapping the Input Record Attribute to the Output Record Attribute	9
About Offline Mediation Controller Statistic Report and ECEDC Log	10

5 IMS CDF/CGF Cartridge Pack

About the IMS CDF/CGF Cartridge Pack	1
Configuring the Diameter CC	2
Creating and Configuring the Diameter Parser EP	2
Creating and Configuring the Session Sequencing EP	2
Configuring the AVP Mapper EP Node	3
Configuring the IMS Session Aggregation AP Node	3
Creating and Configuring the 3GPP IMS ASN.1 DC Node	3
IMS Sample Output	3
Sample Output From an S-CSCF Record in 32.298 ASN.1 Format	3
Sample Output From a P-CSCF Record in 32.298 ASN.1 Format	6
Configuring Node Chain Routing	7
Supported Routing Attributes	8
Known Problems	9
Stopping the Session Aggregation AP Node and the 3GPP IMS ASN.1 DC Node	9
Changing the Expiry Interval Setting on the Session Sequencing EP	10
CDF/CGF Host is Not Uniquely Identified by the Diameter CC Node	10
Diameter AVP (GPRS-Charging-Id) Must Contain an Integer	10

6 IPDRv2 Distribution Cartridge Pack

About the IPDRv2 Distribution Cartridge Pack	1
--	---

7 NetFlow Collection and Processing Cartridge Pack

About the NetFlow Collection and Processing Cartridge Pack	1
Configuring the NetFlow CC Node	2
Configuring the NetFlow Session AP Node	2

8 Configuring the Nortel CS 2000 AMADNS Cartridge Pack

About the Nortel CS 2000 AMADNS Collection Cartridge Pack	1
Configuring the Nortel CS 2000 AMADNS CC Node	1

9 Configuring the Nortel DMS-100 MMP AMA Cartridge Pack

Nortel DMS-100 MMP AMA Collection Cartridge Pack	1
--	---

Creating and Configuring the DMS-100 MMP AMA CC	1
---	---

10 Nortel DMS SMDR Cartridge Pack

About the Nortel DMS SMDR Cartridge Pack	1
Configuring the DMS SMDR CC Node	2
Creating and Configuring the DMS SMDR AP Node	3
Configuring a Custom EP Node	4
Creating and Configuring the DMS SMDR ASCII DC	4
Configuring the DMS SMDR ASCII Fixed Width File DC	5
Configuring the JDBC DC Node	6
Configuring the Node Chains	6
SMDR Collection with ASCII Distribution	6
SMDR Collection with ASCII Fixed Width File Distribution	7
SMDR Collection with Database Distribution	7
SMDR Collection with NAR Distribution	7
Database Storage and Reporting	7
Installing and Configuring	7
Loading the Offline Mediation Controller Schema	8
Known Problems	9

11 Nortel DMS Operational Metrics Cartridge Pack

About the Nortel DMS Operational Metrics Cartridge Pack	1
Configuring the OM Collector CC Node	2
Configuring the OM Distributor DC Node	3

12 Nortel GSM/UMTS AMA Cartridge Pack

About the Nortel GSM/UMTS AMA Cartridge Pack	1
File Errors	3
Configuring the DMS-MSC CC Node	3
Configuring the NRTT CC Node	4
Creating and Configuring the ASCII DC	4
ASCII DC Output Files	5
ASCII DC Sample Output	6
Creating and Configuring the DMS-MSC ASN.1 DC	9
DMS-MSC ASN.1 Sample Output	10
Configuring the JDBC DC Node	11
Creating and Configuring the DMS-MSC AMA DIRP DC	12
Configuring the DMS-MSC NRTT DC Node	14
Configuring the DMS-MSC Active GHOT NRTT DC Node	15

Configuring the Node Chains	15
G-CDR Collection with AMA DIRP File Distribution	16
G-CDR Collection with NRTT Distribution	16
G-CDR and GHOT Collection with AMA DIRP File Distribution	17
G-CDR Collection with AMA DIRP Distribution, GHOT Collection with NRTT Distribution, No Recovery	17
G-CDR Collection with AMA DIRP Distribution, GHOT Collection with NRTT Distribution, Recovery	17
G-CDR and GHOT Collection with ASCII File and Database Distribution	18
Invalid AMA Input File	19
Error Handling in 1:1 File Matching Situations	20
Database Storage and Reporting	22
Installing and Configuring Oracle Database Components	22
Oracle Database Installation Summary	23
Upgrading If AMA 1.4.x Cartridge Packs Were Installed	23
Upgrading If AMA 4.0.0 to 4.0.7 Cartridge Packs Were Installed	24
Upgrade the Database Portion of AMA 3.5. to 3.5.5 For the Parameter (PAR) File Enhancement	26
Loading the Offline Mediation Controller Schema	26
Changing the Default Oracle Username And Password	27
Configuring Oracle Database	28
Configuring Linux Executable	28
Configuring and Using the Repository Manager	29
Adding Entries to the Configuration Table	29
Starting the Repository Manager	31
Stopping the Repository Manager	31
Importing Records with the Repository Manager	31
Deleting Records with the Repository Manager	32
Archiving Records with the Repository Manager	32
Installing the Oracle Client	32
Installing the Oracle JDBC Driver	32
Configuring Oracle Database for Automatic Restart	33
Verifying the Oracle Database Automatic Restart	33
Known Problems	34

13 Configuring the Real-Time ASCII File Collection CDK Cartridge Pack

About the Real-Time ASCII File Collection Cartridge Development Kit (CDK) Cartridge Pack	1
--	---

14 Configuring the SGSN06 Cartridge Pack

About the SGSN06 Cartridge Pack	1
Configuring the GTP Prime CC Node	2

Configuring Input From GPRS Tunneling Protocol	2
Configuring the 3GPP Parsing EP Node	3
Configuring the 3GPP Session Sequencing AP Node	3
Configuring the Session AP Node	3
Configuring the 3GPP ASN.1 DC Node	3
Alarms	4

15 Configuring the Syslog Collection Cartridge Pack

About the Syslog Collection Cartridge Pack	1
Configuring the Syslog CC Node	1
Syslog Rotation On AIX 5.3	1
NAR Attributes and Error Scenarios	2
Known Problems	3

A Sample Mapping for ECE Cartridge Pack

About the Sample Mapping	A-1
Supported Usage Types	A-1
Mapping for ASCII	A-2
Voice	A-2
Data	A-3
Mapping for SGSN	A-5
Data	A-6
SMS	A-7
Mapping for IMS	A-9
Voice	A-10
Mapping for Oracle CDR Format	A-10
Voice	A-10
Data	A-11
SMS	A-12
TelcoGsmTelephony	A-12
TelcoGprs	A-14

B SGSN06 Cartridge Pack Version Hiding Reference

Version Hiding	B-1
S-GW Record	B-1
P-GW Record	B-1
AFChargingIdentifier Field	B-2
AFRecordInformation Field	B-2
MSNetworkCapability Field	B-3

CauseForRecClosing Field	B-4
ChangeCondition Field	B-9
ChangeOfCharCondition Field	B-13
ChangeOfServiceCondition Field	B-17
CSGAccessMode Field	B-26
CSGId Field	B-26
ChargingCharacteristics Field	B-27
EventBasedChargingInformation Field	B-28
EPCQoSInformation Field	B-29
QoSInformation Field	B-31
ListOfTrafficVolumes Field	B-32
RATType Field	B-38
ChChSelectionMode Field	B-39
DynamicAddressFlag Field	B-40
EventTimeStamp Field	B-41
CAMELInformationSMS Field	B-42
SMSResult/Diagnostics Field	B-43
RatingGroupId Field	B-47
ServiceConditionChange Field	B-47
ServingNodeType Field	B-53
SGWChange Field	B-54
TimeQuotaMechanism Field	B-55
TimeQuotaType Field	B-56
UserCSGInformation Field	B-57
ChangeLocation Field	B-57
All Other Fields	B-59

C Offline Mediation Controller Support for 5G Non-Standalone Architecture

Extended Attributes in EPCQoSInformation AVP	C-1
RANSecondaryRATUsageReport AVP	C-1

D Nortel GSM/UMTS AMA Cartridge Pack Supported GSM Releases and Version Hiding

About the Supported GSM Versions	D-1
Version Hiding For GSM 19 Data Fields	D-2
Version Hiding For GSM 18 Data Fields	D-3
Version Hiding For GSM 17 Data Fields	D-7
Version Hiding For GSM 16 Data Fields	D-10
Version Hiding For GSM 15 Data Fields	D-11

E IMS CDF/CGF Cartridge Pack Output Specification

Field Definition Notes	E-1
Value Definitions for AVP Mapper EP Mapping Tables	E-1
Media-Component-List Items	E-4
List-of-Message-Bodies Items	E-5
Early-SDP-Media-Description-List Items	E-5
Real-Time-Tariff-Information Items	E-6

About This Content

This guide provides instructions for using cartridge packs to configure mediation and pre-rating processing in Oracle Communications Offline Mediation Controller.

Audience

This guide is intended for charging experts and developers who configure Offline Mediation Controller node chains.

1

About Cartridge Packs

This chapter provides an overview of the Oracle Communications Offline Mediation Controller Cartridge Packs.

Topics in this chapter:

- [About Cartridge Packs](#)

About Cartridge Packs

Cartridge packs are optional Offline Mediation Controller components that provide functionality for specific mediation or pre-charging functions. [Table 1-1](#) lists the cartridge packs.

Table 1-1 Cartridge Packs

Cartridge Pack	Description
AMA CDK Cartridge Pack	Provides the functionality to collect and process AMA data.
ECE Cartridge Pack	Enables Offline Mediation Controller to submit offline charging requests to ECE.
IMS CDF/CGF Cartridge Pack	Collects raw diameter data from IMS devices, converts that data into 32.298 ASN.1 format, and outputs the data to downstream applications.
IPDRv2 Distribution Cartridge Pack	Processes IP detail records (IPDRs).
NetFlow Collection and Processing Cartridge Pack	Processes Netflow records.
Nortel CS 2000 AMADNS Collection Cartridge Pack	Supports the collection of Nortel CS 2000 SN09 AMADNS records.
Nortel DMS-100 MMP AMA Collection Cartridge Pack	Supports the collection of Nortel DMS-100 MMP AMA (I) SN09 records generated by Nortel DMS-100 switches.
Nortel DMS Operational Metrics Cartridge Pack	Provides functionality to retrieve files containing OM records from various telecom switches and send them to external systems. The OM node chain does not modify OM records; there are no EP or AP nodes.
Nortel DMS SMDR Cartridge Pack	Provides the ability to collect SMDR records from DMS-100 switches.
Nortel GSM/UMTS AMA Cartridge Pack	Provides the functionality to collect AMA data from DMS-MSC SDMs, process that data and send it to downstream applications, such as billing systems and/or databases.
Real-Time ASCII File Collection CDK Cartridge Pack	Collects ASCII records from files in real-time.
SGSN06 Cartridge Pack	Supports 3GPP TS 32.298 V6.4.1, 3GPP TS 32.298 7.3.0, and 3GPP TS 32.298 V10.5.0 for SGSN call data records (CDR).

Table 1-1 (Cont.) Cartridge Packs

Cartridge Pack	Description
Syslog Collection Cartridge Pack	Collects syslog files from multiple devices.

2

Installing Cartridge Packs

This chapter describes how to install and set up Oracle Communications Offline Mediation Controller cartridge packs.

Topics in this chapter:

- [Software Requirements](#)
- [Installing Cartridge Packs](#)
- [Uninstalling a Cartridge Pack](#)
- [List of Cartridge Packs and JAR Files](#)

Software Requirements

Offline Mediation Controller cartridge packs require Offline Mediation Controller 15.1.

Before installing the Nortel CS 2000 AMADNS Collection Cartridge Pack or the Nortel DMS-100 MMP AMA Collection Cartridge Pack, install the AMA CDK Cartridge Pack.

Installing Cartridge Packs

To install cartridge packs:

1. Stop all node managers, administration servers, and administration clients on the system where you are installing the cartridge pack.
2. Delete any existing cartridge pack JAR file from the *OMC_home*/**cartridges** directory, where *OMC_home* is the directory in which Offline Mediation Controller is installed.
[Table 2-2](#) lists the cartridge pack names and JAR file names.
3. Download the cartridge pack from the Oracle software delivery website:
<http://edelivery.oracle.com>
4. Unzip the cartridge kit JAR file to the *OMC_home*/**cartridges** directory.
5. For these cartridges only, copy the JAR file to *OMC_home*/**dbscripts**:
 - Nortel DMS SMDR Cartridge Pack
 - Nortel GSM/UMTS AMA Cartridge Pack
6. Start all node managers, administration servers, and administration clients.
7. Verify that the cartridge pack has been properly installed by viewing **Version Info** from the **Help** menu in Administration Client.

Uninstalling a Cartridge Pack

To uninstall a cartridge pack:

1. Go to the *OMC_home*/**cartridges** directory, where *OMC_home* is the directory in which Offline Mediation Controller is installed.
2. Delete the JAR file for the cartridge. See [Table 2-2](#).
3. For these cartridges only, delete the JAR file from the *OMC_home*/**dbscripts** directory:
 - Nortel DMS SMDR Cartridge Pack
 - Nortel GSM/UMTS AMA Cartridge Pack

You must also remove these cartridges' scripts from the Oracle database. See "[Removing Scripts From the Database](#)".

Removing Scripts From the Database

The following cartridge packs include scripts that you must remove from the Oracle database when you uninstall them:

- Nortel GSM/UMTS AMA Cartridge Pack
- Nortel DMS SMDR Cartridge Pack

To remove the scripts from the Oracle database:

1. Run the following command:

```
Oracle_home/bin/oemapp dbastudio&
```

where *Oracle_home* is the directory in which you installed the Oracle database software.

The **Oracle Enterprise Console** screen appears.

2. Log in using the following information:

user: system

password: oracle

service: NMCDRS

3. In the left frame, expand the **schema** directory and then expand the **NMUSER1** directory, which lists the sub-directories.
4. Expand the sub-directories item by item as follows:
 - Tables
 - Source Types
 - Packages
 - Procedures
 - Functions
 - Java Sources
 - Java Classes

For each sub-directory mentioned above, there are files related to the schema.

5. Right-click on each file and then select **Remove**.
6. Expand the **Storage** directory.
7. Expand the **TableSpace** directory.
8. Right-click on each item and then select **Remove** for the tables listed in [Table 2-1](#).

Table 2-1 Tables to Remove for Each Cartridge Pack

Cartridge Pack	Tables
Nortel GSM/UMTS AMA Cartridge Pack	<ul style="list-style-type: none"> ENHNMCDRS_MAIN TBLSPC_NAME_YYYYMMDD (if a partition table was created) Where TBLSPC_NAME is configured in REPOMAN_CONFIGURATION table
Nortel DMS SMDR Cartridge Pack	<ul style="list-style-type: none"> SMDR_MAIN MSLV_YYYYMMDD (if a partition table was created)

9. (Nortel DMS SMDR Cartridge Pack only) Run the following command as the system user:

```
drop user nmuser1 cascade
```

List of Cartridge Packs and JAR Files

[Table 2-2](#) lists the cartridge packs and their associated JAR file names.

Table 2-2 Cartridge Packs and Their JAR Files

Cartridge Pack	JAR File
AMA CDK Cartridge Pack	ama_cdk_r12_0_0.jar
ECE Cartridge Pack	ocece_r12_0_0.jar
IMS CDF/CGF Cartridge Pack	IMS_R12_0_0.jar
IPDRv2 Distribution Cartridge Pack	ipdr_v2_r12_0_0.jar
NetFlow Collection and Processing Cartridge Pack	netflow_r12_0_0.jar
Nortel CS 2000 AMADNS Collection Cartridge Pack	cs2k_amadns_r12_0_0.jar
Nortel DMS-100 MMP AMA Collection Cartridge Pack	DMS_100_MMP_Collection_R12_0_0.jar
Nortel DMS Operational Metrics Cartridge Pack	om_r12_0_0.jar
Nortel DMS SMDR Cartridge Pack	smdr_r12_0_0.jar
Nortel GSM/UMTS AMA Cartridge Pack	ama_r12_0_0.jar
Real-Time ASCII File Collection CDK Cartridge Pack	realtime_ascii_r12_0_0.jar
SGSN06 Cartridge Pack	sgsn06_r12_0_0.jar
Syslog Collection Cartridge Pack	syslog_r12_0_0.jar

3

AMA CDK Cartridge Pack

This chapter describes how to configure the nodes included in the Oracle Communications Offline Mediation Controller AMA CDK Cartridge Pack.

Topics in this chapter:

- [About the AMA CDK Cartridge Pack](#)
- [Using the AMA CDK Cartridge for CDMA Services](#)
- [Maintaining the Fixed Block Size](#)
- [XML Schema](#)

About the AMA CDK Cartridge Pack

The AMA CDK cartridge pack provides the functionality to collect and process AMA data. The cartridge pack includes these features:

- The **AMAVIEWER** converts AMA files to human-readable XML files.
- The AMA cartridge pack supports incrementing Block Count across output files and Distribution Cartridge (DC) node restarts for CDMA services.

The AMA DNS XML schema allows you to customize the cartridge pack functionality. The schema is packaged inside the cartridge JAR file.

To access the schema:

1. Unpack the JAR file by running this command:

```
jar xvf amadns_r2_1_3.jar
```

2. View the contents of the **AMADNSSchema.xsd** file:

```
com/metasolv/nm/amadns/AMADNSSchema.xsd
<?xml version="1.0" encoding="ISO-8859-1" ?>
<xsd:schema xmlns:xsd="http://www.w3.org/2001/XMLSchema">
  <xsd:annotation>
    <xsd:documentation xml:lang="en">
      AMA DNS Schema. Copyright 2004 MetaSolv Software Inc. All rights reserved.
    </xsd:documentation>
  </xsd:annotation>
  <xsd:element name="definition" type="amaDefType"/>
</xsd:schema>
```

Using the AMA CDK Cartridge for CDMA Services

The AMA cartridge pack supports CDMA services. The AMA DNS XML schema allows you to configure the type of supported service type as either GSM or CDMA.

Add the following field definition to the XML file:

```
<xsd:attribute name="hexStructCode" type="xsd:boolean"/>
<definition name="dms_mtx_15_ama" xmlns:xsd="http://www.w3.org/2001/XMLSchema-instance"
xsd:noNamespaceSchemaLocation="AMADNSSchema.xsd">
```

To specify CDMA or GSM, set the hexadecimal structure code to **true** or **false** respectively.

Sample **amaBlock** in XML file:

```
<?xml version="1.0" standalone="yes"?>
  <amaStructure>
    <amaBlock BDW="false" RDW="false" blockSize="2048" hexStructCode="true">
      <blockHeaderRec>
        <structureCode>193</structureCode>
      </blockHeaderRec>
    </amaBlock>
```

Maintaining the Fixed Block Size

The AMA DNS XML schema allows you to customize the block filler character used to maintain the fixed block size if the block size is not variable. You can specify the block filler character as a regular hexadecimal value. By default, the default block filler is zero.

Sample **amaBlock** in XML file:

```
<amaBlock BDW="false" RDW="true" blockSize="2048" blockFiller="E">
  <xsd:sequence>
</amaBlock>
```

XML Schema

The following is the XML schema for the AMA DNS DC. To access the schema, see "[About the AMA CDK Cartridge Pack](#)".

The XML definition file you create must conform to this schema.

```
<xsd:complexType name="amaDefType">
  <xsd:element name="amaStructure" type="amaStructureType"/>
  <xsd:sequence>
    <xsd:element name="structure" minOccurs="1" maxOccurs="unbounded"
type="structure_module_Type"/>
  </xsd:sequence>
  <xsd:sequence>
    <xsd:element name="module" minOccurs="0" maxOccurs="unbounded"
type="structure_module_Type"/>
  </xsd:sequence>
  <xsd:attribute name="name" type="xsd:string"/>
</xsd:complexType>
<xsd:complexType name="amaStructureType">

  <xsd:sequence>
<xsd:element name="fileHeader" type="fileHeaderType" minOccurs="0" maxOccurs="1"/>
  <!-- File header block, headerBlock should be the first block in the AMA file
and contains no data block -->
  <xsd:element name="headerBlock" type="amaBlockType" minOccurs="0" maxOccurs="1"/>
  <!-- AMA data block -->
  <xsd:element name="amaBlock" type="amaBlockType"/>
  <!-- File footer block, footerBlock should be the last block in the AMA file and
contains no data block -->
  <xsd:element name="footerBlock" type="amaBlockType" minOccurs="0" maxOccurs="1"/>
  <xsd:element name="operationsInFooterRecordOnly" type="operationsType"/>
  <xsd:sequence>
    <xsd:element name="counterInfo" type="counterInfoType" minOccurs="0"
maxOccurs="2"/>
  </xsd:sequence>
```

```

        <xsd:element name="structureCodeField" type="xsd:string"/>
    </xsd:sequence>
</xsd:complexType>
<xsd:complexType name="fileHeaderType">

<xsd:sequence>
<xsd:element name="field" type="fieldType" minOccurs="1" maxOccurs="unbounded"/>
    </xsd:sequence>
</xsd:complexType>
<xsd:complexType name="counterInfoType">

<xsd:sequence>
<xsd:element name="max" type="counter"/>
    <xsd:element name="min" type="counter"/>
    </xsd:sequence>
    <xsd:attribute name="name" type="counterNameType"/>
</xsd:complexType>
<xsd:simpleType name="counterNameType">

<xsd:restriction base="xsd:string">
<xsd:enumeration value="FileCounter"/>
    <xsd:enumeration value="BlockCounter"/>
    </xsd:restriction>
</xsd:simpleType>
<xsd:simpleType name="counter">

<xsd:restriction base="xsd:int">
<xsd:minInclusive value="0"/>
    </xsd:restriction>
</xsd:simpleType>
<xsd:simpleType name="operationsType">

<xsd:restriction base="xsd:string">
<xsd:enumeration
value="getTotalRecordsInFile,getTotalDataRecordsInFile,getTotalBlocksInFile,getTotalRecordsInBlock,getTotalDataRecordsInBlock,getTimeStampFromBlockHeader,getTimeFromBlockHeader,getDateFromBlockHeader,getTimeStampFromFileHeader,getTimeFromFileHeader,getDateFromFileHeader"/>
    </xsd:restriction>
</xsd:simpleType>
<xsd:complexType name="amaBlockType">

<xsd:sequence>
<!-- Block Header Record -->
    <xsd:element name="blockHeaderRec" type="recordType" minOccurs="0"
maxOccurs="1"/>
    <!-- Special header record in this block -->
    <xsd:element name="headerRec" type="recordType" minOccurs="0" maxOccurs="1"/>
    <!-- Special footer record in this block -->
    <xsd:element name="footerRec" type="recordType" minOccurs="0" maxOccurs="1"/>
    </xsd:sequence>
    <!-- Block Descriptor Word is presented or not -->
    <xsd:attribute name="BDW" type="xsd:boolean"/>
    <!-- Record Descriptor Word is presented or not -->
    <xsd:attribute name="RDW" type="xsd:boolean"/>
    <!-- The size of a block -->
    <xsd:attribute name="blockSize" type="blockSizeType"/>
    <xsd:attribute name="blockFiller" type="blockFillerType"/>
</xsd:complexType>
<xsd:complexType name="recordType">

```

```

<xsd:sequence>
<!-- The structure code of a record, should match the "id" in "structure_module_Type". --
>
    <xsd:element name="structureCode" type="xsd:string"/>
</xsd:sequence>
</xsd:complexType>
<xsd:simpleType name="blockSizeType">

<xsd:restriction base="xsd:string">
<xsd:enumeration value="2048"/>
    <xsd:enumeration value="variable"/>
</xsd:restriction>
</xsd:simpleType>
<xsd:simpleType name="blockFillerType">

<xsd:restriction base="xsd:string">
<xsd:pattern value="[0-9a-fA-F]{1}"/>
    </xsd:restriction>
</xsd:simpleType>
<xsd:complexType name="structure_module_Type">

<xsd:sequence>
<!-- Structure code or module code -->
    <xsd:element name="id" type="xsd:string"/>
    <xsd:sequence>
        <!-- This element is for Module only. -->
        <xsd:element name="allowedstruct" type="xsd:string" minOccurs="0"
maxOccurs="unbounded"/>
        </xsd:sequence>
        <xsd:sequence>
            <xsd:element name="field" type="fieldType" minOccurs="1"
maxOccurs="unbounded"/>
            </xsd:sequence>
            <xsd:sequence>
                <xsd:attribute name="name" type="xsd:string"/>
                <xsd:attribute name="multivalued" type="xsd:boolean"/>
            </xsd:complexType>
            <xsd:complexType name="fieldType">

<xsd:sequence>
<xsd:element name="length" type="xsd:int"/>
    <xsd:element name="narid" type="xsd:string"/>
    <xsd:element name="pattern" type="xsd:string" minOccurs="0" maxOccurs="1"/>
    <xsd:element name="default" type="xsd:string" minOccurs="0" maxOccurs="1"/>
    <xsd:element name="const" type="xsd:string" minOccurs="0" maxOccurs="1"/>
    </xsd:sequence>
    <xsd:attribute name="name" type="xsd:string"/>
    <xsd:attribute name="signdelimited" type="xsd:boolean"/>
    <xsd:attribute name="signCharacterInRegularValue" type="signCharType"/>
    <xsd:attribute name="signCharacterInNullValue" type="signCharType"/>
    <xsd:attribute name="max" type="xsd:int"/>
    <xsd:attribute name="min" type="xsd:int"/>
    <xsd:attribute name="operation" type="operationType"/>
    <xsd:attribute name="spacePrefix" type="xsd:boolean"/>
    <xsd:attribute name="encoding" type="encodingType"/>
</xsd:complexType>
<!-- Define field encoding type. -->

<!-- By default (if not defined in XML), encoding type is BCD. -->
<xsd:simpleType name="encodingType">
    <xsd:restriction base="xsd:string">
        <xsd:enumeration value="BCD"/>
    </xsd:restriction>
</xsd:simpleType>

```

```

        <xsd:enumeration value="EBCDIC"/>
    </xsd:restriction>
</xsd:simpleType>
<!-- Define sign character if a field is sign delimited. -->

<!-- By default (if not defined in XML), sign character is "c" in regular value, for
example, "03dc". -->
<!-- By default (if not defined in XML), sign character is "f" in null value, for
example, "ffff". -->
<xsd:simpleType name="signCharType">
    <xsd:restriction base="xsd:string">
        <xsd:enumeration value="f"/>
        <xsd:enumeration value="c"/>
    </xsd:restriction>
</xsd:simpleType>
<xsd:simpleType name="operationType">

<xsd:restriction base="xsd:string">
<!-- Get total number of records in the file, only available in File Footer -->
    <xsd:enumeration value="getTotalRecordsInFile"/>
    <!-- Get total number of data records (excluding header/footer records) in the
file, only available in File Footer -->
    <xsd:enumeration value="getTotalDataRecordsInFile"/>
    <!-- Get file name -->
    <xsd:enumeration value="getFileName"/>
    <!-- Get DMS MSC AMA (GSM 13, 15, and 16) time stamp -->
    <xsd:enumeration value="getDmsMscTimeStamp"/>
    <!-- Get DMS MSC AMA GSM 17 time stamp -->
    <xsd:enumeration value="getDmsMscGsm17TimeStamp"/>
    <!-- Get AMA DNS time stamp (includes date and time) -->
    <xsd:enumeration value="getAmaDnsTimeStamp"/>
    <!-- Get AMA DNS time of day -->
    <xsd:enumeration value="getAmaDnsTime"/>
    <!-- Get AMA DNS date -->
    <xsd:enumeration value="getAmaDnsDate"/>
    <!-- Get file sequence number -->
    <xsd:enumeration value="getFileSequenceNumber"/>
    <!-- Get total number of blocks in a file, only available in File Footer --
>
    <xsd:enumeration value="getTotalBlocksInFile"/>
    <!-- Get block identifier, for multiple switch system -->
    <xsd:enumeration value="getBlockIdentifier"/>
    <!-- Get block sequence number -->
    <xsd:enumeration value="getBlockSequenceNumber"/>
    <!-- Get total number of records in a block, only available in Block
Footer -->
    <xsd:enumeration value="getTotalRecordsInBlock"/>
    <!-- Get total number of data records (excluding header/footer records) in a
block, only available in Block Footer -->
    <xsd:enumeration value="getTotalDataRecordsInBlock"/>
    <!-- Use this operation if the field value is presented in the input NAR -->
    <xsd:enumeration value="getValueFromFieldContainer:Key"/>
    <!-- These are for block footer only, use them if you want the timestamp in the
block footer is the same as the one in the block header. -->
    <xsd:enumeration value="getTimeStampFromBlockHeader"/>
    <xsd:enumeration value="getTimeFromBlockHeader"/>
    <xsd:enumeration value="getDateFromBlockHeader"/>
    <!-- These are for footer only, use them if you want the timestamp in the
footer is the same as the one in the file header. -->
    <xsd:enumeration value="getTimeStampFromFileHeader"/>
    <xsd:enumeration value="getTimeFromFileHeader"/>
    <xsd:enumeration value="getDateFromFileHeader"/>

```

```
        <!-- Ignore this field -->
        <xsd:enumeration value="ignore"/>
    </xsd:restriction>
</xsd:simpleType>
</xsd:schema>
```

4

Elastic Charging Engine Cartridge Pack

This chapter describes how to configure and use the Oracle Communications Offline Mediation Controller Elastic Charging Engine Cartridge Pack.

Topics in this chapter:

- [About the ECE Cartridge Pack](#)
- [Integrating ECE and Offline Mediation Controller](#)
- [Configuring the ECE DC Node](#)
- [Editing the ECE DC Rule File](#)

About the ECE Cartridge Pack

The ECE cartridge pack includes the ECE Distribution Cartridge (DC) node that enables Offline Mediation Controller to submit offline charging requests to ECE.

The ECE cartridge pack is used with the following existing cartridge packs to process the input records:

- Simple ASCII
- IMS
- SGSN

[Figure 4-1](#) shows the architecture of the ECE DC node.

Figure 4-1 ECE DC Node Configuration Architecture

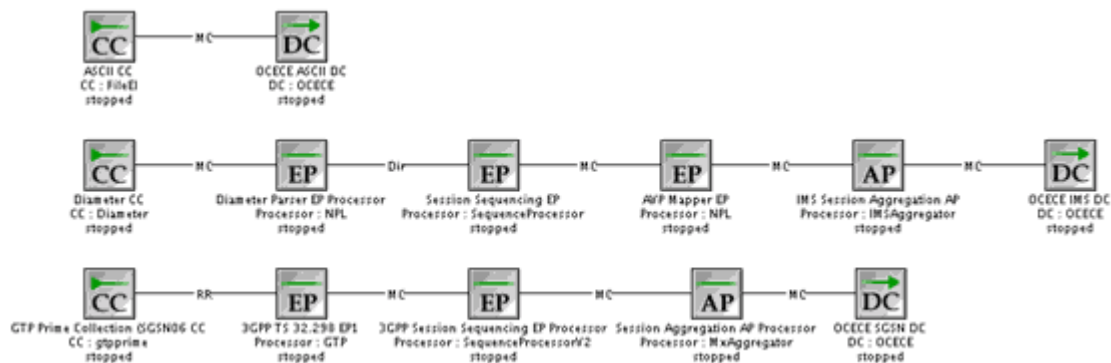

Integrating ECE and Offline Mediation Controller

Before using the ECE Cartridge Pack to create node chains, you need to configure ECE and Offline Mediation Controller to work together. The procedures differ depending on whether ECE and Offline Mediation Controller are installed on the same system.

Integrating When Offline Mediation Controller and ECE are on the Same System

To configure Offline Mediation Controller to support ECE when both are installed on the same system:

1. Open the `OMC_home/bin/UDCEnvironment` file in a text editor.
2. Set the `IS_OCECE_REQUIRED` parameter to **true**. This enables Offline Mediation Controller to interface with ECE.

```
IS_OCECE_REQUIRED=true
```
3. Set the `OCECE_HOME_PATH` parameter to the directory in which ECE is installed. For example:

```
OCECE_HOME_PATH=/home/opt/OracleCommunications/ECE
```
4. Save and close the file.
5. Start Offline Mediation Controller. See "Starting Offline Mediation Controller" in *Offline Mediation Controller Installation Guide*.

Integrating When ECE and Offline Mediation Controller are on Different Systems

To configure ECE and Offline Mediation Controller when they are installed on different systems:

Note

Ensure that ECE is installed on a system within the same sub-network as the system on which Offline Mediation Controller is installed.

1. On the system where ECE is installed, open the `ECE_home/occeserver/config/charging-coherence-override-dev.xml` file in a text editor, where `ECE_home` is the directory in which ECE is installed.
2. Uncomment the following element:

```
<well-known-addresses>  
  <socket-address id="1">  
    <address system-property="tangosol.coherence.wka">localhost</address>  
    <port system-property="tangosol.coherence.wka.port">18088</port>  
  </socket-address>  
</well-known-addresses>
```
3. In the **address** element, replace **localhost** with the IP address of the system on which ECE is installed:

```
<address system-property="tangosol.coherence.wka">ip_address</address>
```
4. In the **time-to-live** element, set the value to **1**:

```
<time-to-live system-property="tangosol.coherence.ttl">1</time-to-live>
```
5. In the **cluster-name** element, set the value to the ECE cluster name. For example:

```
<cluster-name system-property="tangoso1.coherence.cluster">BRM</cluster-name>
```

6. Save and close the file.
7. Copy the *ECE_home* directory to the system where Offline Mediation Controller is installed.
8. On the system where Offline Mediation Controller is installed, open the *OMC_home/bin/UDCenvironment* file in a text editor.
9. Set the **IS_OCECE_REQUIRED** parameter to **true**. This enables Offline Mediation Controller to interface with ECE.

```
IS_OCECE_REQUIRED=true
```

10. Set the **OCECE_HOME_PATH** parameter to the location of *ECE_home* on your Offline Mediation Controller system. For example:

```
OCECE_HOME_PATH=/home/opt/OracleCommunications/ECE
```

11. Save and close the file.
12. Start ECE in the system where ECE is installed.
13. Start Offline Mediation Controller. See "Starting Offline Mediation Controller" in *Offline Mediation Controller Installation Guide*.

Configuring the ECE DC Node

You send output to ECE by using the ECE DC node.

[Table 4-1](#) shows the options to configure in the **OCECE Configuration** tab.

Table 4-1 OCECE Configuration Tab

Field	Description
Batch size	The number of records that will be submitted by OCOMC to ECE before waiting for responses. Larger batch sizes may help improve throughput. Larger batches may require the "Waiting time per batch" to be increased to permit all responses to be received from ECE before submitting the next batch.
Max records per suspense/success file	Maximum number of records per file written in the <i>OMC_home/ocomc/suspense</i> or the <i>OMC_home/ocomc/success</i> directory. The minimum value is 1 and the maximum value is 50000.
Waiting time per batch	Time in milliseconds the node waits for the batch to be processed. The minimum value is 1 and the maximum value is 1800000.
Timeout for Archiving NAR file	The frequency at which partially filled no-response, duplicate, and bad NAR records will be closed and moved to their corresponding destination locations. This permits partially filled files of failed NARs to be closed and moved (the max file size is controlled by the "OCECESuspenseBatchSize" configuration or, by default, will be 10000 records).
Response Timeout	The frequency with which the ECE DC Node will check for requests that have not received a response from ECE. The records are stored in memory until there is a response. Any record which has been waiting for a response for more than the "Response Timeout" will be written to the no-response NAR file. Note that as this parameter controls both the timeout and the frequency with which this check is run, a no-response would be detected at latest two times the value of this timeout.

Table 4-1 (Cont.) OCECE Configuration Tab

Field	Description
Request Throttling	In cases where the ECE server may not be responding as quickly as normal it can be helpful to pause submission of more work for a short time. When enabled, the number of outstanding requests will be checked after each batch and if larger than the "High-Water Mark", processing of the record stream will be halted until the number of outstanding requests drops below the "Low-Water Mark".
Output bad records as NAR	Generates a NAR for the bad records.
Log success records	Enables writing the records successfully processed by ECE to the file in the <i>OMC_home/ocomc/success</i> directory. The ECE DC node logs successfully processed ECE records to the success file when the advice of charge notification in ECE is set to include events such as an in-session notification on the usage response message (PIGGYBACK). See the ECE documentation for more information about configuring advice of charge notifications.
Submission-throttling milliseconds	Whilst "Request Throttling" controls submission at a batch level, the micro-throttling feature permits throttling of submission within a batch of records as a flow-control mechanism. If, at any time, the number of outstanding requests (those sent to the ECE server but for which responses have not been received) exceeds the "Max outstanding requests before throttling" configuration, the ECE DC Node will add a pause before submitting new requests to ECE. This configuration controls how long that pause will be (in milliseconds).
Max outstanding requests before throttling	Controls the maximum number of outstanding requests that will be permitted before the ECE DC Node begins pausing the submission of requests to ECE. See "Submission-throttling milliseconds" which defines how long each pause will be. Once the number of outstanding requests drops below this threshold, records will be submitted normally.
Max MSCC batch size	In cases where there are multiple input records in each batch that are for the same user identity, it is possible to group those records into a single request for the ECE server to permit them to be processed together. This can optimize throughput in cases where a large proportion of records are for a small number of distinct user identities. Typical values would be in the range of 1 to 10. There is generally little additional benefit from using larger batch sizes (and none in cases where all user identities are distinct).
Number of threads for group submission	Specifies how many parallel threads are used for processing and submitting grouped batches of records. When set to a value greater than 0, that many threads will be used to process groups of records. Set to 0 to process groups sequentially and disable multi-threaded submission.
Number of threads for NPL processing	Indicates the number of parallel threads dedicated to running the Node Processing Language (NPL) rules during record pre-processing, invoking the group EntryProcessor . A higher value enables concurrent pre-processing for increased performance but should be set according to available CPU resources and system stability needs.

Note

By default, suspended CDRs are stored in the directory **OMC_home/suspense**. You can change the default directory using the **Output Directory Configuration** tab in the ECE DC node.

[Table 4-2](#) shows the options to configure the output directories in ECE DC node along with their default configurations.

Table 4-2 Output Directory Configuration Tab

Field Name	Default Configuration
Duplicate request directory	<code>OMC_home/output/nodeid/duplicate</code>
Duplicate response directory	<code>OMC_home/output/nodeid/duplicateresponse</code> (Must be created manually by the user)
Success response directory	<code>OMC_home/output/nodeid/success</code> (Must be created manually by the user)
Suspense directory	<code>OMC_home/suspense</code>
No-response directory	<code>OMC_home/output/nodeid/noreponse</code>
Delayed response directory	<code>OMC_home/output/nodeid/delayedresponse</code>

Note

The Success response and Duplicate response directory are not created automatically by the system. Users must manually create these directories at the specified paths after configuring the node.

Editing the ECE DC Rule File

When creating and configuring the ECE Distribution Cartridge (DC) node, you configure a rule file containing the mapping data from the network accounting record (NAR) format to an output format for use by ECE. For more information about editing rule files, see *Offline Mediation Controller Cartridge Development Kit NPL Reference Guide*.

When configuring the ECE DC node, define the following in the rule file:

- [Configuration Block](#)
- [Input Record Block](#)
- [Output Record Block](#)
- [Expose Block for PAYLOAD](#)
- [Expose Block for Payload Data Type](#)
- [Expose Block for Usage Object](#)

Configuration Block

A configuration block is used to set configuration values that are needed by the node. You can define only one configuration block in an NPL rule file.

Syntax

```

Config {
PRODUCTTYPES "product_type[, ...]";
PAYLOAD "payload_type[, ...]";
PAYLOADDATATYPE "datatype";
USAGEOBJECTS "usage_object";
EVENT "event_type[, ...]";
VERSION "version_number[, ...]";
MODE "usage_request_mode";
TIME_ZONE "time_zone";
DATE_FORMAT "date_format";
USAGE_REQUEST_BUILDER "request_format";
}

```

Configuration Settings

PRODUCTTYPES "product_type[, ...]";

where *product_type* is a product type defined in ECE. This parameter is specific to the product types the ECE DC processes.

PAYLOAD "payload_type[, ...]";

where *payload_type* is the payload type defined in ECE.

PAYLOADDATATYPE "datatype";

where *datatype* specifies the data type used in payloads.

USAGEOBJECTS "usage_object";

where *usage_object* specifies the usage objects type. The default value is **USAGEBUILDER**.

EVENT "event_type[, ...]";

where *event_type* specifies the types of events. Add the *event_type* values separated by commas.

VERSION "version_number[, ...]";

where *version_number* specifies the version for each record corresponding to the product type. Add the *version_number* values separated by commas.

MODE "usage_request_mode";

where *usage_request_mode* specifies the mode in which Offline Mediation Controller sends usage requests to ECE. Set the parameter to one of the following values:

- **CUMULATIVE**: Specifies that the balance impact in ECE is cumulative.
- **INCREMENTAL**: Specifies that the balance impact in ECE is incremental.

TIME_ZONE "time_zone";

where *time_zone* specifies the time zone used by the ECE DC node to send the session start time and the session end time to ECE. The default value is **UTC**. The time zone is set at record level or at cartridge level:

- Record level: If the NPL output record block contains the **timeZone** field, the time zone is set at record level. For record level time zone, each call detail record (CDR) can have a different time zone defined by the **timeZone** field in the CDR.

- Cartridge level: If the configuration block contains **TIME_ZONE** field, the time zone is set at cartridge level. All the CDRs processed by the cartridge will contain the same time zone as defined by the **TIME_ZONE** field.

Note

If the time zone is defined at record level and at cartridge level, the record level time zone is used.

DATE_FORMAT "*date_format*";

where *date_format* specifies the date format used by ECE DC to send the session start time and the session end time to ECE. The default value is **yyyy-MM-dd HH:mm:ss**.

USAGE_REQUEST_BUILDER "*request_format*";

where *request_format* defines the usage request builders. This parameter creates the builders for the corresponding product type, event, and version.

For example:

```
Config {
PRODUCTTYPES "VOICE,DATA,SMS";
PAYLOAD "VOICE_USAGE_Terminate_PAYLOAD,VOICE_USAGE_Update_PAYLOAD,
VOICE_USAGE_Debit_unit_PAYLOAD,VOICE_USAGE_Refund_unit_PAYLOAD,
VOICE_USAGE_Refund_amount_PAYLOAD,VOICE_USAGE_Debit_amount_PAYLOAD,
DATA_DATA_USAGE_Terminate_PAYLOAD,DATA_DATA_USAGE_Update_PAYLOAD,
DATA_DATA_USAGE_Debit_unit_PAYLOAD,DATA_DATA_USAGE_Refund_unit_PAYLOAD,
DATA_DATA_USAGE_Refund_amount_PAYLOAD,DATA_USAGE_Debit_amount_PAYLOAD,
SMS_SMS_USAGE_Terminate_PAYLOAD,SMS_SMS_USAGE_Debit_unit_PAYLOAD,
SMS_SMS_USAGE_Refund_unit_PAYLOAD,SMS_SMS_USAGE_Refund_amount_PAYLOAD,
SMS_SMS_USAGE_Debit_amount_PAYLOAD";
PAYLOADDATATYPE "PAYLOADDATATYPE";
USAGEOBJECTS "USAGEBUILDER";
EVENT "USAGE,DATA_USAGE,SMS_USAGE";
VERSION "1.0";
MODE "CUMULATIVE";
TIME_ZONE "UTC";
DATE_FORMAT "yyyy-MM-dd HH:mm:ss";
USAGE_REQUEST_BUILDER "VOICE@USAGE@1.0,DATA@DATA_USAGE@1.0,SMS@SMS_USAGE@1.0";
}
```

Input Record Block

An input record block defines the fields in the input data record passed into the node.

Syntax

```
InputRec {
datatype parameter;
} in;
```

Where:

datatype is the data type of the input field; for example, **String**.

parameter is the input field name.

For example:

```

InputRec {
    String calling_number;
    Integer seq_no;
    Integer duration;
    String start_time;
    String product_type;
    String session_id;
    String CalledId;
    String end_time;
    String cell_id;
    String requestedInputVolume;
    String requestedOutputVolume;
    String requestedTotalVolume;
    String usedUnitsInputVolume;
    String usedUnitsOutputVolume;
    String usedUitsTotalVolume;
    String operationType;
    String correlation_identifier;
    String balance_element_id;
    String amount;
    // String timeZone;
} in;

```

Output Record Block

An output record block is used to define the format of an output data record of the node.

Syntax

```

OutputRec {
    datatype parameter;
} out;

```

Where:

datatype is the data type of the output field; for example, **String**.

parameter is the output field name.

For example:

```

OutputRec {
    String calling_number;
    Integer seq_no;
    String duration;
    String start_time;
    String end_time;
    String product_type;
    String session_id;
    String CalledId;
    String npl_type;
    String cdr_service;
    String cell_id;
    String requestedInputVolume;
    String requestedOutputVolume;
    String requestedTotalVolume;
    String usedUnitsInputVolume;
    String usedUnitsOutputVolume;
    String usedUitsTotalVolume;
    Integer usedUnitsSpecificUnit;
    String eventType;
    String version;
}

```

```

        String operationType;
        String correlation_identifier;
        Integer balance_element_id;
        Double amount;
        // String timeZone;
    } out;

```

Expose Block for PAYLOAD

For every payload type in the configuration block, define an Expose block. In the Expose block, map the NPL fields to the ECE Payload fields defined in the ECE request specifications.

For example:

```

Expose for VOICE_PAYLOAD{out.CalledId "CALLED_ID";out.duration
"REQUESTED_UNITS[0].DURATION";}
Expose for DATA_PAYLOAD{out.cell_id "CELL_ID";
out.requestedInputVolume "REQUESTED_UNITS[0].INPUT_VOLUME";
out.requestedOutputVolume "REQUESTED_UNITS[0].OUTPUT_VOLUME";
out.requestedTotalVolume "REQUESTED_UNITS[0].TOTAL_VOLUME";
out.usedUnitsInputVolume "USED_UNITS[0].INPUT_VOLUME";
out.usedUnitsOutputVolume "USED_UNITS[0].OUTPUT_VOLUME";
out.usedUitsTotalVolume "USED_UNITS[0].TOTAL_VOLUME";}

```

Expose Block for Payload Data Type

For every payload data type in the configuration block, define an Expose block. In the Expose block, define the data type for the fields that are passed in the payload data type.

For example:

```

Expose for PAYLOADDATATYPE{out.duration "SECONDS";
out.requestedInputVolume "VOLUME";
out.requestedOutputVolume "VOLUME";
out.requestedTotalVolume "VOLUME";
out.usedUnitsInputVolume "VOLUME";
out.usedUnitsOutputVolume "VOLUME";
out.usedUitsTotalVolume "VOLUME";}

```

Expose Block for Usage Object

For every usage object type in the configuration block, define an Expose block. In the Expose block, map the NPL fields that are sent as parameters in the create usage objects method.

For example:

```

Expose for USAGEBUILDER{
out.calling_number "PARAM1";
out.session_id "PARAM2";
out.start_time "PARAM3";
out.end_time "PARAM4";
out.seq_no "PARAM5";
}

```

Mapping the Input Record Attribute to the Output Record Attribute

When mapping the input record attribute to the output record attribute, set the following output fields based on the specific product type for which the CDR is received:

- **cdr_service:** Set this field to the product types for each CDR record.

- **eventType**: Set this field to the event type for each CDR record corresponding to the product type.
- **version**: Set this field to the version for each CDR record corresponding to the product type.
- **operationType**: Set this field to the usage type for each CDR record corresponding to the product type.

See the sample mapping for the ECE cartridge pack in *Offline Mediation Controller Cartridge Development Kit NPL Reference Guide* for more information about the supported usage types.

For example:

```
out.cdr_service="VOICE"out.eventType="USAGE"out.version="1.0"out.operationType="Terminate"
```

About Offline Mediation Controller Statistic Report and ECEDC Log

Offline Mediation Controller statistic reports (located at **ocomc/adminsvr/statistics/reports**) offer a high-level view of Call Detail Record (CDR) processing for various cartridges, detailing counts like incoming, outgoing, and discarded CDRs. However, ECEDC employs a dedicated log file for in-depth statistics. This log accumulates data from startup until restart and resides in the `ocomcHome/log/<nodeId>` directory. Analysing these statistics provides insights into received requests, rejections, submissions, response rates (including success, failure, and timeouts), and unprocessed records.

For error handling and missing response investigation, utilities like `NARComparator` and `RatedEventsChecker` can be employed. These tools help identify issues with reconciliation between the `NoResponse` and `Delayed` response NARs and aid in segregating records that needs to be resubmitted for usage processing.

The following is a sample statistics snippet that is printed in the cartridge log file:

```
Requests received : 3#EOR#
Requests rejected : 0#EOR#
Requests submitted : 3#EOR#
Responses sent by ECE : 3#EOR#
SUCCESS responses : 3 out of which 2 are DUPLICATE#EOR#
FAILURE responses : 0#EOR#
SUCCESS Delayed responses received 0 out of which 0 are DUPLICATE#EOR#
FAILURE Delayed responses received : 0#EOR#
No_Response records within the stipulated time : 0#EOR#
```

5

IMS CDF/CGF Cartridge Pack

This chapter describes how to configure the nodes included in the Oracle Communications Offline Mediation Controller IMS CDF/CGF Cartridge Pack.

Topics in this chapter:

- [About the IMS CDF/CGF Cartridge Pack](#)
- [Configuring the Diameter CC](#)
- [Creating and Configuring the Diameter Parser EP](#)
- [Creating and Configuring the Session Sequencing EP](#)
- [Configuring the AVP Mapper EP Node](#)
- [Configuring the IMS Session Aggregation AP Node](#)
- [Creating and Configuring the 3GPP IMS ASN.1 DC Node](#)
- [IMS Sample Output](#)
- [Configuring Node Chain Routing](#)
- [Supported Routing Attributes](#)
- [Known Problems](#)

About the IMS CDF/CGF Cartridge Pack

The IMS node chain collects raw diameter data from IMS devices, converts that data into 32.298 ASN.1 format, and outputs the data to downstream applications as shown in [Figure 5-1](#).

Figure 5-1 Architecture

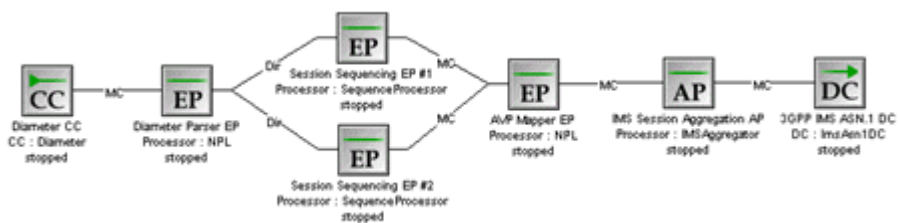

This cartridge supports the following:

- Support for Cause-Code AVP value of -4.
- Compliance with 3GPP Technical Specification 32.298 V10.5
- Compliance with 3GPP Technical Specification 32.260 V10.4
- Compliance with 3GPP Technical Specification 32.299 V10.2

- Compliance with 3GPP Technical Specification 32.298 V16.4.1.1

Configuring the Diameter CC

To receive data from Diameter network elements, you use the Diameter CC node.

[Table 5-1](#) shows the options to configure in the **Diameter** tab.

Table 5-1 Diameter Tab

Field	Description
Receive Port	The port that the node monitors for incoming Diameter connections.
Request Timer	The amount of time, in seconds, the node waits for Diameter records to be transferred during an established connection before disconnecting from the remote device.
Origin Host	The hostname, unique within IMS. This can be the fully qualified domain name of the worker node.
Origin Realm	The domain of the Origin Host value.
Host IP Address	The IP address of the Offline Mediation Controller worker node.
Vendor ID	The unique vendor ID. It can use AVP 10415 for identification.
Product Name	Unique product name, such as ims-voip .
Acct Interim Interval	The interval for interim accounting messages, which should be set to 60 seconds.

Creating and Configuring the Diameter Parser EP

The Diameter Parser EP receives raw diameter data from the CC and converts that data into diameter types, then sends the data to the next node in the chain, usually the Session Sequencing EP. There are no specialized tabs in the Diameter Parse EP configuration.

Creating and Configuring the Session Sequencing EP

The Session Sequencing EP organizes CDRs into the correct chronological sequence and removes duplicate records. The EP then passes the files to the next node in the chain, which is the AVP Mapper EP.

Note

You must configure two Session Sequencing EPs. For the first EP, select the **IMS R6 Event De-Duplication** rule file. For the second EP, select the **IMS R6 Sequence Processing** rule file.

[Table 5-2](#) shows the options to configure in the **Sequencing** tab.

Table 5-2 Sequencing Tab

Option	Description
Expiry Interval (minutes)	Enter the time the node waits, before the sequence records output are sent to the next node in the chain.
Log Duplicate Entries	Select this check box to enable the node to create a log entry for each duplicate record.
Missing Record Monitoring	Select this check box to enable the node to generate alarms or logs for any missing records it detects.
Missing Record Alarm or Log Severity	Select the alarm severity level or log option that the node will generate for a missing record.

Configuring the AVP Mapper EP Node

The AVP Mapper EP is responsible for converting the incoming Diameter AVPs into their equivalent 32.298 ASN.1 format. There are no specialized tabs in the AVP Mapper EP configuration.

For the exact mapping of Diameter AVP to ASN.1 fields, see "[IMS CDF/CGF Cartridge Pack Output Specification](#)".

Configuring the IMS Session Aggregation AP Node

The IMS Session Aggregation AP is responsible for compiling record sessions, and passing these files on to the 3GPP IMS ASN.1 DC. In addition to the standard configuration tabs, you can configure the node to create partial records. To do so, enter a value in minutes in the **Partial Generation** tab.

Creating and Configuring the 3GPP IMS ASN.1 DC Node

The 3GPP IMS ASN.1 DC node converts files to ASN.1 format and then outputs the files to a downstream system. To configure the node you enter file output, FTP connections, and file retention.

IMS Sample Output

This section lists the IMS sample outputs.

Sample Output From an S-CSCF Record in 32.298 ASN.1 Format

The following is IMS sample output from an S-CSCF record in 32.298 ASN.1 format, converted to readable text.

```

* * * * * Record 1 * * * * *
32.298 v 10.5.0 IMS CDR
-----
value IMSRecord ::= sCSCFRecord : {
  recordType sCSCFRecord,
  role-of-Node terminating,
  nodeAddress domainName : "cscf.nn.com",
  session-Id "5e5e-0884-39f4-bb1e6e62@47.129.74.198",

```

```

list-Of-Calling-Party-Address {
  sIP-URI : "sip:004nigelfull@di.com"
},
called-Party-Address tEL-URI : "10.13.4.3",
privateUserID "004nigelfullprv@di.com",
serviceRequestTimeStamp '0501280850512B0000'H,
serviceDeliveryStartTimeStamp '0501280850542B0000'H,
recordOpeningTime '1203190334362B0000'H,
recordClosureTime '1203190334362B0000'H,
interOperatorIdentifiers {
  {
    originatingIOI "nigel.com",
    terminatingIOI "nigel.com"
  }
},
localRecordSequenceNumber 0,
causeForRecordClosing timeLimit,
incomplete-CDR-Indication {
  aCRStartLost FALSE,
  aCRInterimLost unknown,
  aCRStopLost TRUE
},
ims-Charging-Identifier
'3133355F313130363933323335373434364034372E3234382E36372E3433'H,
list-Of-SDP-Media-Components {
  {
    sIP-Request-Timestamp '0501280850512B0000'H,
    sIP-Response-Timestamp '0501280850542B0000'H,
    sDP-Media-Components {
      {
        sDP-Media-Name "Video Conference",
        sDP-Media-Descriptions {
          "a=video conference"
        },
        authorized-QoS "Gold"
      }
    },
    mediaInitiatorFlag NULL,
    sDP-Session-Description {
      "a=Video Conference"
    },
    sIP-Request-Timestamp-Fraction 123456,
    sIP-Response-Timestamp-Fraction 234567,
    sDP-Type sDP-offer,
    localGWInsertedIndication TRUE,
    iPRealmDefaultIndication TRUE,
    transcoderInsertedIndication TRUE
  }
},
gGSNaddress iPAddress : iPBinaryAddress : iPBInV4Address : '0A0D05E0'H,
serviceReasonReturnCode "-302",
list-Of-Message-Bodies {
  {
    content-Type "application/sdp",
    content-Disposition "Disposition",
    content-Length 3420720,
    originator sIP-URI : "2"
  }
},
expiresInformation 12345,
accessNetworkInformation '4163636573734E6574776F726B496E666F726D6174696F6E'H,
serviceContextID "MNC.MCC.11.32260@3gpp.org",

```

```

list-of-subscription-ID {
  {
    subscriptionIDType eND-USER-IMSI,
    subscriptionIDData "SubscriptionIdData1"
  }
},
list-Of-Early-SDP-Media-Components {
  {
    SDP-Media-Components {
      {
        SDP-Media-Name "Video Conference 1",
        SDP-Media-Descriptions {
          "sdp media description- video conference"
        },
        authorized-QoS "Gold"
      }
    },
    mediaInitiatorFlag NULL,
    SDP-Session-Description {
      "a=my sdp session description 1"
    },
    SDP-Type sDP-offer
  }
},
IMSCommunicationServiceIdentifier '496D73436F6D6D5376634964'H,
numberPortabilityRouting "DataForNPRI",
carrierSelectRouting "DataForCSRI",
sessionPriority pRIORITY-1,
serviceRequestTimeStampFraction 123456,
serviceDeliveryStartTimeStampFraction 234567,
applicationServersInformation {
  {
    applicationServersInvolved domainName : "sip:47.135.114.225:5060",
    applicationProvidedCalledParties {
      sIP-URI : "10.13.5.91"
    }
  }
},
requested-Party-Address tEL-URI : "RequestedPartyAddress",
list-Of-Called-Asserted-Identity {
  sIP-URI : "sip:Called-Asserted-Identity-1"
},
online-charging-flag NULL,
realTimeTariffInformation {
  tariffInformation : {
    currencyCode 840,
    scaleFactor { mantissa 3075, base 2, exponent 2 },
    rateElements {
      {
        unitType 1,
        unitValue { mantissa 3075, base 2, exponent 2 },
        unitCost { mantissa 3075, base 2, exponent 2 },
        unitQuotaThreshold { mantissa 105, base 2, exponent 1 }
      }
    }
  }
}
}

```

Sample Output From a P-CSCF Record in 32.298 ASN.1 Format

The following is IMS sample output from a P-CSCF record in 32.298 ASN.1 format, converted to readable text.

```

* * * * * Record 1 * * * * *
32.298 v 10.5.0 IMS CDR
-----
value IMSRecord ::= pCSCFRecord : {
  recordType pCSCFRecord,
  role-of-Node terminating,
  nodeAddress domainName : "cscf.nn.com",
  session-Id "5e5e-0884-39f4-bb1e6e62@47.129.74.198",
  list-Of-Calling-Party-Address {
    sIP-URI : "sip:004nigelfull@di.com"
  },
  called-Party-Address tEL-URI : "10.13.4.3",
  serviceRequestTimeStamp '0501280850512B0000'H,
  serviceDeliveryStartTimeStamp '0501280850542B0000'H,
  recordOpeningTime '1203210136242B0000'H,
  recordClosureTime '1203210136242B0000'H,
  interOperatorIdentifiers {
    originatingIOI "nigel.com",
    terminatingIOI "nigel.com"
  },
  localRecordSequenceNumber 1,
  causeForRecordClosing timeLimit,
  incomplete-CDR-Indication {
    aCRStartLost FALSE,
    aCRInterimLost unknown,
    aCRStopLost TRUE
  },
  ims-Charging-Identifier
'3133355F313130363933323335373434364034372E3234382E36372E3433'H,
  list-Of-SDP-Media-Components {
    {
      sIP-Request-Timestamp '0501280850512B0000'H,
      sIP-Response-Timestamp '0501280850542B0000'H,
      sDP-Media-Components {
        {
          sDP-Media-Name "Video Conference",
          sDP-Media-Descriptions {
            "a=video conference"
          },
          authorized-QoS "Gold"
        }
      },
      mediaInitiatorFlag NULL,
      sDP-Session-Description {
        "a=Video Conference"
      },
      sIP-Request-Timestamp-Fraction 123456,
      sIP-Response-Timestamp-Fraction 234567,
      sDP-Type sDP-offer,
      localGWInsertedIndication TRUE,
      iPRealmDefaultIndication TRUE,
      transcoderInsertedIndication TRUE
    }
  },
  gGSNAddress ipAddress : ipBinaryAddress : ipBinV4Address : '0A0D05E0'H,
  serviceReasonReturnCode "-302",

```

```

list-Of-Message-Bodies {
  {
    content-Type "application/sdp",
    content-Disposition "Disposition",
    content-Length 3420720,
    originator sIP-URI : "2"
  }
},
expiresInformation 12345,
accessNetworkInformation '4163636573734E6574776F726B496E666F726D6174696F6E'H,
list-of-subscription-ID {
  {
    subscriptionIDType eND-USER-SIP-URI,
    subscriptionIDData "SubscriptionIdData"
  }
},
list-Of-Early-SDP-Media-Components {
  {
    sDP-Media-Components {
      {
        sDP-Media-Name "Video Conference 1",
        sDP-Media-Descriptions {
          "sdp media description- video conference"
        },
        authorized-QoS "Gold"
      }
    },
    mediaInitiatorFlag NULL,
    sDP-Session-Description {
    },
    sDP-Type sDP-offer
  }
},
iMSCommunicationServiceIdentifier '496D73436F6D6D5376634964'H,
sessionPriority pRIORITY-1,
serviceRequestTimeStampFraction 123456,
serviceDeliveryStartTimeStampFraction 234567,
list-Of-Called-Asserted-Identity {
  tEL-URI : "CalledAsserterQuantity1"
},
iMSApplicationReferenceIdentifer '496D734170705265664964'H
}

```

Configuring Node Chain Routing

Both multicast and directed routing are supported in specific parts of the IMS node chain. The purpose for using directed routing is to route records with particular attributes to one node or node stream, and route records with other specific attributes to a different node or node stream.

Directed routing is supported between the Diameter Parser EP and the two Session Sequencing EPs. For the directed routing connection between the Diameter Parser EP and the first Session Sequencing EP (with the **IMS R6 Event De-Duplication** rule file), select the **Accounting-Record-Type** attribute and set the value equal to one. For the directed routing connection between the Diameter Parser EP and the second Session Sequencing EP (with the **IMS R6 Sequence Processing** rule file), select the **Accounting-Record-Type** attribute and set the value **not** equal to one.

[Figure 5-2](#) shows the default configuration for the node chain routing.

Figure 5-2 Node Chain Routing - Default Configuration

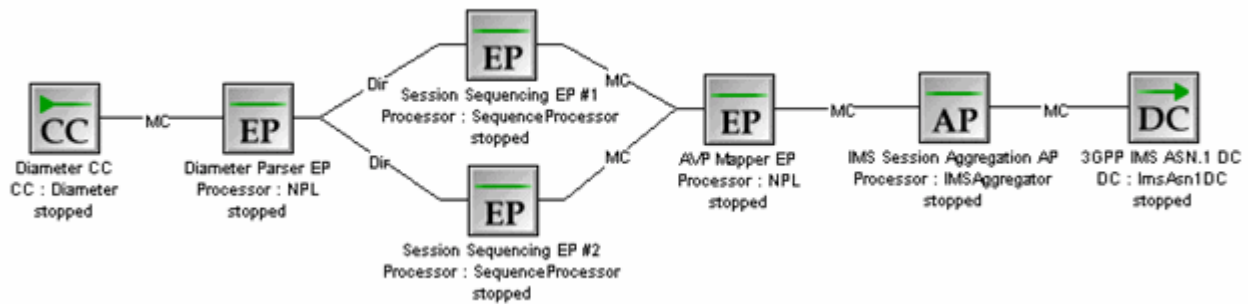

In addition to the default node chain configuration, you can add another 3GPP IMS ASN.1 DC, and use directed routing from the IMS Session Aggregation AP to each DC. For example, you can configure directed routing on the **RecordType** attribute, and send S-CSCF records to one DC and P-CSCF records to the other DC. When configuring directed routing for the S-CSCF record stream, select the **RecordType** attribute, and set the value equal to 63. When configuring directed routing for the P-CSCF record stream, select the "RecordType" attribute, and set the value **not** equal to 63.

[Figure 5-3](#) shows the alternate configuration for the node chain routing.

Figure 5-3 Node Chain Routing - Alternate Configuration



Supported Routing Attributes

The supported routing attributes between the Diameter Parser EP and the Session Sequencing EP are:

- Session-Id
- Origin-Host
- Origin-Realm
- Destination-Realm
- Accounting-Record-Type
- Accounting-Record-Number
- Acct-Application-Id
- User-Name
- Acct-Interim-Interval

- Origin-State-Id
- Role-of-Node
- User-Session-Id
- Calling-Party-Address
- Called-Party-Address
- Application-server
- Application-provided-called-party-address
- IMS-Charging-Identifier
- Authorized-QoS
- Service-Id
- Node-Functionality
- Retransmitted

The supported routing attributes between the Session Aggregation AP and the 3GPP IMS ASN.1 DC are:

- Accounting-Record-Number
- TimeStamp
- RecordType
- Retransmission
- SIP_Method
- Role_of_Node
- Session_Id
- PrivateUserID
- LocalRecordSequenceNumber
- RecordSequenceNumber
- CauseForRecordClosing
- ServiceDeliveryFailureReason

Known Problems

The following are the known problems for the IMS CDF/CGF Cartridge Pack.

Stopping the Session Aggregation AP Node and the 3GPP IMS ASN.1 DC Node

Editing or stopping and starting the Session Aggregation AP and the 3GPP IMS ASN.1 DC while they are processing data can result in Offline Mediation Controller generating the following warning alarm:

```
Configuration; NPL originated Critical log; A record contains an incorrect value in the field/AVP Accounting-Record-Type. This record will be processed as an ACR-Stop.
```

There is also the possibility of duplicate record generation.

To work around this issue:

1. Stop the Session Sequencing EP node.
2. Wait for all records to propagate through the Session Aggregation AP node and the 3GPP IMS ASN.1 DC. All records are propagated when Current NARs = 0 for more than 5 seconds in the Node Performance view of the Administration window.
3. Proceed with the stop or edit operation.
4. Save or start the node.
5. Start the Session Sequencing EP.

Note

If the Session Sequencing EP is stopped for a period longer than its flush timer setting, duplicate records may appear.

Changing the Expiry Interval Setting on the Session Sequencing EP

Changing the Expiry Interval setting on the Session Sequencing EP affects new input records only. The EP still flushes any records waiting to be sequenced according to the pre-configured setting. There is no work around.

CDF/CGF Host is Not Uniquely Identified by the Diameter CC Node

When the Diameter CC node constructs the ACA (Accounting-Answer) in response to the ACR (Accounting-Request) the values for Origin-Host and Origin-Realm are obtained from the values in the ACR and therefore do not uniquely identify the CDF/CGF host. There is no work around.

Diameter AVP (GPRS-Charging-Id) Must Contain an Integer

According to the 3G Technical Specification, the GPRS-Charging-Id field is declared as type INTEGER and therefore the CCF requires that the associated Diameter AVP (GPRS-Charging-Id) contain an integer and not a string . Otherwise the node will skip the field and raise the following warning alarm:

```
Configuration; Error occurred in NPL; Exception occurred in the NPL assignment statement on line 150. Exception is java.lang.ClassCastException: For input string: "GPRS #1" NPL execution continuing with next statement.
```

6

IPDRv2 Distribution Cartridge Pack

This chapter describes the Oracle Communications Offline Mediation Controller IPDRv2 Distribution Cartridge Pack.

Topics in this chapter:

- [About the IPDRv2 Distribution Cartridge Pack](#)

About the IPDRv2 Distribution Cartridge Pack

This cartridge processes IP detail records (IPDRs).

7

NetFlow Collection and Processing Cartridge Pack

This chapter describes how to configure the nodes included in the Oracle Communications Offline Mediation Controller NetFlow Collection and Processing Cartridge Pack, which collects and aggregates Cisco NetFlow records.

Topics in this chapter:

- [About the NetFlow Collection and Processing Cartridge Pack](#)
- [Configuring the NetFlow CC Node](#)
- [Configuring the NetFlow Session AP Node](#)

About the NetFlow Collection and Processing Cartridge Pack

This cartridge pack is for NetFlow collection and processing:

- The NetFlow Collection Cartridge (CC) collects the Cisco NetFlow v1, v5, and v7 records.
- The NetFlow Session Aggregation Processor (AP) aggregates Cisco NetFlow (V1, V5, and V7) records which have the following attributes:
 - Source IP addresses
 - Destination IP addresses
 - Source port number
 - Destination port number
 - IP protocol type
 - Day of year and hour

Each aggregated NetFlow session record contains the above information as well as total bytes, and total packets.

The NetFlow Collection and Processing cartridge pack will aggregate, into a single record on an hourly basis, NetFlow records belonging to the same NetFlow session. After the user-configured flush timer has expired, the AP will output the aggregated records.

[Figure 7-1](#) displays the architecture of the solution.

Figure 7-1 Netflow Architecture

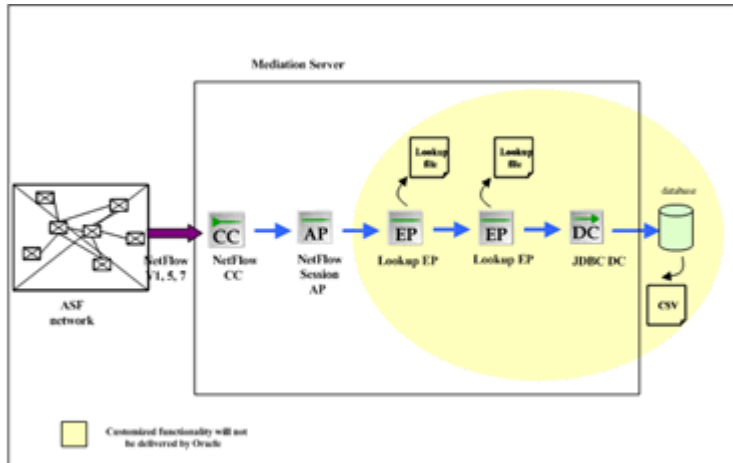

Configuring the NetFlow CC Node

The NetFlow Collection Cartridge (CC) collects the Cisco NetFlow v1, v5, and v7 records.

[Table 7-1](#) shows the options to configure in the **NetFlow** tab.

Table 7-1 NetFlow Tab

Field	Description
NetFlow Port	Port number that NetFlow uses to report mediation data. Default is 9995.
Socket Buffer Size	UDP receiving socket buffer size. Value recommended is 65 536

Configuring the NetFlow Session AP Node

The NetFlow Session Aggregation Processor (AP) aggregates Cisco NetFlow (V1, V5, and V7) records. This node uses the standard aggregation node configuration options.

8

Configuring the Nortel CS 2000 AMADNS Cartridge Pack

This chapter describes how to configure the nodes included in the Oracle Communications Offline Mediation Controller Nortel CS 2000 AMADNS Cartridge Pack.

Topics in this chapter:

- [About the Nortel CS 2000 AMADNS Collection Cartridge Pack](#)
- [Configuring the Nortel CS 2000 AMADNS CC Node](#)

About the Nortel CS 2000 AMADNS Collection Cartridge Pack

The Nortel CS 2000 AMADNS Collection cartridge pack supports the collection of Nortel CS 2000 SN09 AMADNS records. The AMADNS files produced by the Nortel Communication Server 2000 (CS 2000) will be either FTP pushed to the CS 2000 CC or FTP pulled from the Nortel CS 2000 Carrier Voice over IP softswitch through an intermediate FTP server.

The CS 2000 AMADNS records are sent from the Nortel CS 2000 AMADNS CC node to the Nortel CS 2000 AMADNS DC node.

Configuring the Nortel CS 2000 AMADNS CC Node

The Nortel CS 2000 AMADNS CC node receives Nortel CS 2000 SN09 AMADNS records.

To configure the Nortel CS 2000 AMADNS CC node, you configure standard parameters, include FTP connection configurations.

There are two rule files you can use:

- Nortel CS 2000 SN09 AMADNS. This is the default.
- Reprocess - Nortel CS 2000 SN09 AMADNS. Use this rule file when there is no match with the Service Provider Lookup file. This can be used in a separate instance of the node, placed after the default implementation in the node chain.

9

Configuring the Nortel DMS-100 MMP AMA Cartridge Pack

This chapter describes how to use the Oracle Communications Offline Mediation Controller Nortel DMS-100 MMP AMA Cartridge Pack.

Topics in this chapter:

- [Nortel DMS-100 MMP AMA Collection Cartridge Pack](#)
- [Creating and Configuring the DMS-100 MMP AMA CC](#)

Nortel DMS-100 MMP AMA Collection Cartridge Pack

The Nortel DMS-100 MMP AMA Collection Cartridge (CC) pack supports the collection of Nortel DMS-100 MMP AMA (I) SN09 records generated by Nortel DMS-100 switches.

The CC supports FTP pushing AMA files from the Nortel SDM to the NM server. Collection of G-CDR is supported.

Creating and Configuring the DMS-100 MMP AMA CC

To configure the DMS-100 MMP AMA CC node, you configure standard parameters, include FTP connection configurations.

10

Nortel DMS SMDR Cartridge Pack

This chapter describes how to configure the nodes included in the Oracle Communications Offline Mediation Controller Nortel DMS SMDR Cartridge Pack.

Topics in this chapter:

- [About the Nortel DMS SMDR Cartridge Pack](#)
- [Configuring the DMS SMDR CC Node](#)
- [Creating and Configuring the DMS SMDR AP Node](#)
- [Configuring a Custom EP Node](#)
- [Creating and Configuring the DMS SMDR ASCII DC](#)
- [Configuring the DMS SMDR ASCII Fixed Width File DC](#)
- [Configuring the JDBC DC Node](#)
- [Configuring the Node Chains](#)
- [Database Storage and Reporting](#)
- [Loading the Offline Mediation Controller Schema](#)
- [Known Problems](#)

About the Nortel DMS SMDR Cartridge Pack

The Nortel DMS SMDR Cartridge Pack provides the ability to collect SMDR records from DMS-100 switches.

Switches according to the specification DMS100 Family North American DMS-100 Station Message Detail Recording Reference Guide, DMSCCM12 Standard 19.03 October 2000. The cartridge pack also filters, enhances and distributes SMDR records to multiple destinations, including a Billing Centre and an Oracle database.

The cartridge pack includes the following nodes:

- DMS SMDR CC
- DMS SMDR AP
- DMS SMDR ASCII DC
- DMS SMDR ASCII Fixed Width File DC

In addition, the Nortel DMS SMDR node chains include a JDBC DC node, and a custom EP node that you create.

[Figure 10-1](#) displays the architecture of the SMDR solution.

Figure 10-1 SMDR Solution

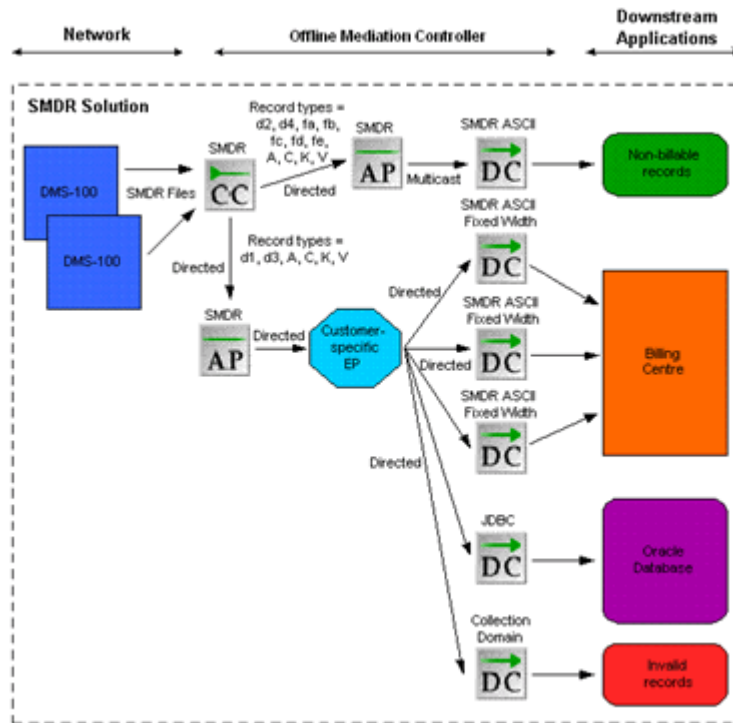

Configuring the DMS SMDR CC Node

The DMS SMDR CC node is responsible for collecting SMDR files from DMS-100 switches. The CC node uses FTP to periodically transfer SMDR/DIRP-encoded files from each switch. One DMS SMDR CC node can poll and transfer files from many switches. The CC node makes the Record Code attribute available for routing, which enables records to be separated into billable and non-billable streams.

To create and configure the DMS SMDR CC node, you configure standard options, file management options, and connection options.

[Table 10-1](#) shows the options to configure in the **Settings** tab.

Table 10-1 DMS SMDR CC Node Settings Tab

Field	Description
Directory for unprocessed files	Local directory to store unprocessed files from the device.
Directory for bad data files	Local directory to store bad or invalid data files.
Delete or Keep processed files	Select a button to delete or keep processed files.
Directory for processed files	Local directory to store files that have been processed by the CC.
Duration to keep each file	Amount of time the processed files are kept in the local directory. Enter a numeric value and select Days or Hours from the drop-down list.
Unprocessed file prefix	File prefix of unprocessed files on the remote device.

Table 10-1 (Cont.) DMS SMDR CC Node Settings Tab

Field	Description
Rename Unprocessed to Processed	Select this checkbox if you want the CC to rename the files on the remote device after successful transfer via FTP.
Processed file prefix	File prefix of processed files on the remote device.
Retries per poll	Number of additional FTP attempts for each polling interval. If the node is unable to retrieve the files, it raises an alarm and will not attempt to re-poll the device until the next scheduled poll interval.
Polling interval	Time interval between FTP polls.
Process daily at fixed time	Select this checkbox if you want the CC to align its polling schedule to a specific time of day. Set the time of day using the drop-down lists.

You add devices to the **Device List** tab. When you add a device, you configure the options shows in [Table 10-2](#).

Table 10-2 DMS SMDR CC Node Device List Tab

Field	Description
Name	Name of the device.
IP Address	IP address of the device.
Port	Port to connect to on the device.
FTP User ID	User or account ID of the device.
Password/Confirm Password	Password of the device.
Disk Volumes	The disk volume name. The disk volumes are non-delimited location names for files. Multiple disk volumes can be added per device.

Creating and Configuring the DMS SMDR AP Node

The DMS SMDR AP node allows the hexadecimal value of the following fields to be mapped to the corresponding text name:

- Console-Number = Attendant Console Name (from A records)
- Customer-Group-Number = Customer Group Name (from C records)
- Origination ID = Trunk Group CLLI (from K records) or Virtual Facility Group Name (from V records)

The DMS SMDR AP node maps the customer-group translation records (C records), attendant console records (A records), virtual facility group name records (V records), and trunk-group-CLLI records (K records) for each DMS-100 switch. The AP tags SMDR records with the text names for each hexadecimal identifier. This allows you to direct records to specific locations based on the text names instead of the changeable hexadecimal identifier. The AP node makes the following attributes available for routing: Office ID, Attendant Console Name, Customer Group Name, Trunk Group CLLI, and Virtual Facility Group Name.

To configure the DMS SMDR AP node you configure standard options and aggregation options.

```

9999999999
d14161690201409058362214 4000003138a0072aaa0
00091142260000162099054703179
9999999999
d14161690201409058368721 4000003138a0075aaa0
00091141320000852099054707011
9999999999
d1416169020143138a0070 4100013061a0069aaa0
00091142190001420097057264153
9999999999
d1416169020143138a006 4000015037a0006
00091138330003810099058984657
9999999999
d14161690201409058368721 4000003138a0068aaa0
00091144450000102099057294825
9999999999
d1416169020143138a0076 4000015037a0004
00091141540001920099058950337
9999999999
d1416169020143138a0069 4100015037a0007
00091142450001400099058360988
9999999999
d1416169020143138a007c 4000015037a0010
00091137140004890099058984657
9999999999
d14161690201409058366584 4000003138a006daaa0
00091144550000282099057965436
9999999999
d14161690201409058364857 4000003138a007baaa0
00091144000000882099058295404
9999999999
d1416169020143138a006c 4100015037a0008
00091145020000330099054765507
9999999999
t141616902014040109040109 00000002500000000000000000000000

```

Configuring the JDBC DC Node

The SMDR AP sends a copy of all SMDR records to the JDBC DC node for storage in the database. The original file name of the SMDR file from which a CDR originated is stored in the database.

Configuring the Node Chains

The most common node chains are:

- [SMDR Collection with ASCII Distribution](#)
- [SMDR Collection with ASCII Fixed Width File Distribution](#)
- [SMDR Collection with Database Distribution](#)
- [SMDR Collection with NAR Distribution](#)

SMDR Collection with ASCII Distribution

To configure the node chain for SMDR collection with ASCII distribution, you must create and configure a DMS SMDR CC node, DMS SMDR AP node and a DMS SMDR ASCII DC node. Connect the CC node to the AP node by using directed routing with the Record Code attribute.

You can connect the AP node to the DC node by using Multicast routing. The DMS SMDR ASCII DC node outputs all incoming fields for each record. These records can be used internally and not for billing since they are not in the fixed width format.

SMDR Collection with ASCII Fixed Width File Distribution

To configure the node chain for SMDR collection with ASCII fixed width file distribution, use the DMS SMDR CC node you created for the previous chain, then create and configure an additional DMS SMDR AP node and one or more DMS SMDR ASCII Fixed Width File DC nodes. Connect the CC node to the AP node by using directed routing with the Record Code attribute. You can connect the Customer specific EP node to the DC node by using Multicast routing if you want the files to be output based on a customer and switch combination. You can connect the Customer specific EP to multiple DC nodes by using directed routing based on the available fields for routing. The DMS SMDR ASCII Fixed Width DC node outputs records in a fixed width format for billing purposes.

SMDR Collection with Database Distribution

To configure the node chain for SMDR collection with database distribution, you must use the DMS SMDR CC node and the EP node you created previously, and create and configure a Database Storage and Reporting DC node. Connect the EP node to the DC node by using Multicast routing. The DC node outputs records to the Oracle database for storage.

SMDR Collection with NAR Distribution

To configure the node chain for SMDR collection with NAR distribution, you must use the DMS SMDR CC node and the EP node you created previously, and create and configure a DC node. Connect the EP node to the DC node using Multicast routing. This DC node outputs records using the Offline Mediation Controller internal NAR format. At this point, you can use the Oracle Communications Offline Mediation Controller Record Editor tool to correct any invalid records and then reintroduce them to the DMS SMDR CC node for processing.

Database Storage and Reporting

The Database Storage and Reporting functionality allows you to configure DMS-MSR node chains that can process and distribute data to both a billing system and an Oracle database.

Installing and Configuring

To install and configure the database components, see *Offline Mediation Controller Installation Guide*.

The Database Storage tasks are as follows:

- Creating an Oracle user and dba group
- Installing Oracle
- Verifying the Oracle installation
- Loading the Offline Mediation Controller schema
- Configuring Oracle
- Configuring Linux executables
- Configuring and using the Repository Manager

- Installing the Oracle Client
- Modifying tnsnames.ora
- Installing the Oracle JDBC driver
- Configuring Oracle for automatic restart
- Verifying the Oracle automatic restart

Loading the Offline Mediation Controller Schema

Use the following procedure to load the Offline Mediation Controller schema.

To load the schema:

1. As the oracle user, run the Oracle Enterprise Manager by typing **oemapp worksheet** and pressing **Enter**.
2. Select **connect directly to database**.
3. For Username, type **system**.
4. For Password, type **Oracle**.
5. For Service, type **NMCDRS**.
6. For Connect, type **normal**.
7. Click **OK**.

You are now connected to the NMCDRS schema.

8. Navigate to the directory where the SMDR jar file was un-jarred.
For example: **/opt/test/dbstorage/Oracle19c**
9. As the oracle SYSTEM user, load the following tablespace:
DDL_create_tblspc_SMDRS_MAIN
This is a default tablespace, and does not store daily CDRs.
10. After loading this script, modify the DATAFILE to match the directory structure on the machine where you installed Oracle.
For example: *Oracle_Home/oradata/dbf.filename*
11. Set the SIZE parameter to a minimum of **10M** (ten megabytes).
12. As the oracle SYSTEM user, load **DDL_create_usr_NMUSER1.sql**.
13. Disconnect as the SYSTEM user and connect as NMUSER1. The default password is NMUSER1.
14. Ensure you are in the directory where the SMDR jar file was un-jarred.
For example: **/opt/test/dbstorage/Oracle19c**
15. Load **DDL_create_tbl_MSLV_SMDR_STORAGE.sql**.
16. Go to: *<directory where you un-jarred the SMDR jar file>/dbstorage/Oracle19c/RepoMan*.
17. Load **DDL_create_tbl_SMDR_REPOMAN_CONFIGURATION.sql**.
18. Load **PLSQL_SMDR_PKG.sql**.
19. Load **PLSQL_SMDR_LOGTOFILE.sql**.
20. Load **JAVA_UTIL.sql**.

21. Load PLSQL_RUN_CMD.sql.
22. Load PLSQL_RC.sql.
23. Load PLSQL_SMDR_PARFILEWRITER.sql.
24. Load PLSQL_BUILD_SMDR_EXCHANGE.sql.
25. Load PLSQL_DROP_SMDR_PARTITIONS.sql.
26. Load PLSQL_BUILD_SMDR_PARTITIONS.sql.
27. Load PLSQL_MSLV_START_SMDR_REPOMAN.sql.
28. Load PLSQL_MSLV_STOP_SMDR_REPOMAN.sql.

All required Oracle objects are now loaded into Oracle database.

Known Problems

The following are known problems for this cartridge pack:

- The DMS SMDR CC node raises a major alarm when it receives a file with a name longer than 30 characters.
- The SMDR discard count parameter does not appear in the Offline Mediation Controller statistics report file.

11

Nortel DMS Operational Metrics Cartridge Pack

This chapter describes how to configure the nodes included in the Oracle Communications Offline Mediation Controller Nortel DMS Operational Metrics Cartridge Pack.

Topics in this chapter:

- [About the Nortel DMS Operational Metrics Cartridge Pack](#)
- [Configuring the OM Collector CC Node](#)
- [Configuring the OM Distributor DC Node](#)

About the Nortel DMS Operational Metrics Cartridge Pack

The Nortel DMS Operational Metrics (OM) cartridge pack provides functionality to retrieve files containing OM records from various telecom switches and send them to external systems. The OM node chain does not modify OM records; there are no EP or AP nodes.

The OM node chain includes two nodes, OM Collector CC node and the OM Distributor DC node.

The OM Collector CC node receives OM files from DMS-100 switches. The node uses FTP to periodically connect and pull files from each switch. A single node can retrieve files from multiple switches. The polling period is a single value used for all switches that are assigned to the node. On a single switch, OM files can be found on multiple volumes, so the node polls multiple directories on each switch.

The OM Collector CC node retrieves files from one or more DMS switches, re-names the files and transfers them to a local directory. The node does not parse or process the individual OM records. Therefore, the node does not produce a NAR file and Offline Mediation Controller is unaware of the contents of the OM records.

The OM Collector CC node re-names the files in the following way:

- DMS file name: R040625145027OM
- OM CC file name: **AAA_R040625145027OM.done**

The node adds a three-letter prefix, underscore and appends **.done** to the incoming file name. The three letters range in the following way: [A-Z][A-Z][A-Za-z]. The prefix differentiates input files from different IP addresses, port numbers and disk volume combinations. Note that the prefix can change if the device configuration is modified.

In the event that the OM Collector CC node cannot communicate with a DMS-100, it attempts to re-establish a connection after a configurable delay. You can also configure the number of times the node attempts to re-establish the connection before raising a critical alarm. The node raises the alarm in both the GUI and via SNMP and logs the incident to the cartridges log file. At this point, the node considers the poll to have failed and does not attempt to re-establish a connection with the switch until the next scheduled poll.

You can provision a backup OM Collector CC node as a means to recover from a polling failure rather than wait for the next scheduled poll. For example, if the log file of the primary node

indicates a polling failure, you can manually configure the backup node to have a short polling interval, such as 5 minutes, for a specific switch. The backup node will collect the files the primary node failed to capture. After the files have been transferred successfully, you can stop the backup node. This backup method can be used to manually initiate polls to switches instead of waiting a longer period for the primary node to attempt to re-establish the connection.

The OM Distributor DC node receives DIRP encoded OM files from the OM Collector CC node and transfers these files to downstream applications using FTP.

📌 Important

Note the following:

- You must deploy the OM CC and DC nodes on the same server.
- Input stream monitoring is not supported.
- In the Node Performance window, there are no counts associated with the nodes.

Configuring the OM Collector CC Node

To configure the OM Collector CC node, you set file management options and device access options.

[Table 11-1](#) shows the options to configure in the **Settings** tab.

Table 11-1 Settings Tab

Field	Description
Directory for Unprocessed Files	Directory where files are copied to from the device. The OM Collector CC node retrieves the file.
Unprocessed File Prefix	File prefix of unprocessed data files received from the remote device.
Rename Unprocessed to Processed	If enabled, the OM Collector CC node renames the files after a successful FTP transfer.
Processed File Prefix	File prefix of processed files.
Retries per poll	Number of additional FTP attempts for each polling interval.
Polling interval	Time interval between FTP polls; for example, 1 hour.
Process daily at fixed time	If enabled, the OM Collector CC node aligns its polling schedule to a specific time of day.
Interrupt timer delay	For example, 1 minute

You add devices to the **Device List** tab. When you add a device, configure the options shown in [Table 11-2](#).

Table 11-2 Device List Tab

Field	Description
Name	Name of the device.
IP Address	IP address of the device.

Table 11-2 (Cont.) Device List Tab

Field	Description
Port	Port to connect to on the device.
FTP User ID	User or account ID of the device.
Password/Confirm Password	Password of the device.
Disk Volumes	The disk volume name. The disk volumes are non-delimited location names for files. Multiple disk volumes can be added per device.

Configuring the OM Distributor DC Node

The OM Distributor DC node receives DIRP-encoded OM files from the OM Collector CC node and transfers these files to downstream applications using FTP Push or Pull. To configure the OM Distributor DC node, you configure standard FTP and file retention options.

12

Nortel GSM/UMTS AMA Cartridge Pack

This chapter describes how to configure the Oracle Communications Offline Mediation Controller Nortel GSM/UMTS AMA Cartridge Pack.

Topics in this chapter:

- [About the Nortel GSM/UMTS AMA Cartridge Pack](#)
- [File Errors](#)
- [Configuring the DMS-MSC CC Node](#)
- [Configuring the NRTT CC Node](#)
- [Creating and Configuring the ASCII DC](#)
- [Creating and Configuring the DMS-MSC ASN.1 DC](#)
- [Configuring the JDBC DC Node](#)
- [Creating and Configuring the DMS-MSC AMA DIRP DC](#)
- [Configuring the DMS-MSC NRTT DC Node](#)
- [Configuring the DMS-MSC Active GHOT NRTT DC Node](#)
- [Configuring the Node Chains](#)
- [Database Storage and Reporting](#)
- [Known Problems](#)

About the Nortel GSM/UMTS AMA Cartridge Pack

The AMA cartridge pack provides the functionality to collect AMA data from DMS-MSC SDMs, process that data and send it to downstream applications such as billing systems and/or databases. The cartridge pack includes nodes that are responsible for collecting, processing and distributing the data. The DMS-MSC CC node collects G-CDR and GHOT records from DMS-MSC SDMs and these records are distributed in AMA DIRP, ASCII or ASN.1 format to downstream billing systems and to databases for storage and search capabilities.

The cartridge pack includes Input Stream Monitoring on the DMS-MSC CC node, NRTT CC node and on all DC nodes. Input stream monitoring is enabled on a per-cartridge basis to detect whether any records have been received for an operator-defined period of time. The nodes raise an alarm when they do not receive any new records within a specified time period, and clear the alarm when it begins to receive records again.

[Figure 12-1](#) shows the G-CDR collection of AMA DIRP files.

Figure 12-1 AMA Architecture with G-CDR Collection in AMA DIRP File Format

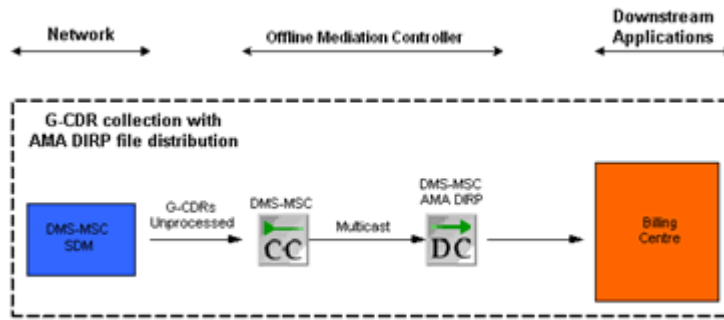

Figure 12-2 shows the G-CDR collection with NRTT distribution.

Figure 12-2 AMA Architecture with G-CDR Collection in NRTT Distribution

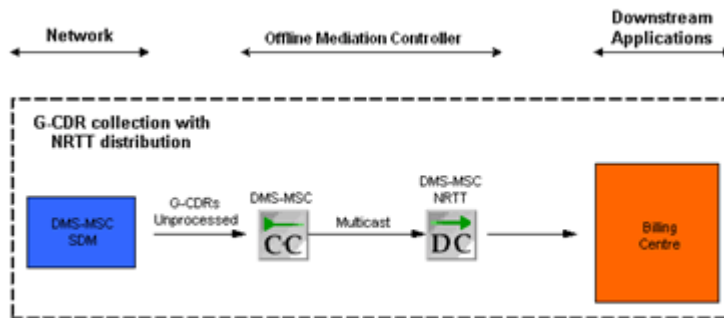
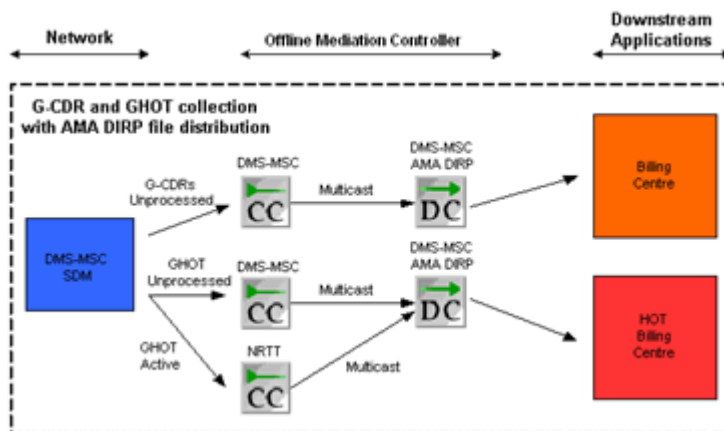

Figure 12-3 shows G-CDR and GHOT collection in AMA DIRP file format.

Figure 12-3 AMA Architecture with G-CDR and GHOT Collection in AMA DIRP File Format



File Errors

The AMA DIRP file that the nodes move to the bad file directory retains its original name. The name of the error report file is in the format *AMA_DIRP_filename_error_report.txt*.

There are two types of errors:

- An error in the DIRP file structure. For example, the size of the record is corrupted. When the DMS-MSC CC node detects this error, the remaining information in the file is no longer readable. In this case, the node processes the AMA DIRP file up to the position where the error was detected. The node cannot process the remainder of the file.
- An error within an AMA record. For example, an unknown module code index. When the DMS-MSC CC node detects this error, it stops processing the record. The remaining information in the AMA DIRP file is still reliable, so the node continues processing, starting with the next AMA record.

The error report identifies the position of the processed and unprocessed AMA records.

Configuring the DMS-MSC CC Node

This section contains information on the requirements for creating and configuring the DMS-MSC CC node.

The DMS-MSC CC node will generate a warning alarm if it has not received any data files from a device for a period of time. The operator can configure a different time interval for each node. The DMS-MSC CC node will clear the alarm when it receives a new input file. The input stream monitoring functionality can be enabled or disabled via the node configuration window.

The input stream monitoring feature should only be used when the node is operating in FTP mode. In Open-FTP mode, the node should normally receive no records, and therefore this monitoring feature should be disabled. However, the node cannot automatically do this. The user must manually disable this feature when choosing Open-FTP mode.

To configure the DMS-MSC CC node, configure standard options and the options in the **AMA CC** tab. [Table 12-1](#) shows the options to configure in the **AMA CC** tab.

Table 12-1 AMA CC Tab

Field	Description
Select the Transport	Select FTP Push or Open FTP .
Input directory	The directory the DMS-MSC SDM system sends CDRs to on the Offline Mediation Controller system.
Bad File directory	The directory to hold the AMA DIRP files that contain errors. When the DMS-MSC CC node detects a bad AMA DIRP file, it moves the file to this directory and creates an error report file that it writes to this directory. The node raises an alarm in the GUI and writes an error log to the node log file.
File completion extension	The expected file extension that the DMS-MSC CC node adds to the AMA DIRP file when the FTP is complete. There is no default extension. If the field is left blank, the transferring SDM does not add an extension when the file transfer is complete.

Table 12-1 (Cont.) AMA CC Tab

Field	Description
Check for new files period	Defines the period that the node waits before checking the input directory for a new AMA DIRP file. The range is 1 second to 60 minutes.
Keep/Delete processed files	Controls whether the node deletes the processed AMA DIRP file or keeps the processed file for a user-defined period of time.
Keep processed files directory	Becomes active if you configure the node to keep the processed files. You must specify the directory where the node will store the processed files. The processed files will be prefixed with P .
Keep processed files duration	Becomes active if you configure the node to keep the processed files. You must specify how long the node will keep the processed files. The range is 1 hour to 60 days.
Keep/Delete recovery files	Indicates whether to track previously processed files. To prevent duplicate record processing, select Keep .
Keep recovery files duration	Becomes active if you configure the node to keep the recovery files. You must specify how long the node will keep the recovery files. The range is 1 hour to 60 days.
Process Files	Indicates the file types that are being processed. In FTP Push mode, all input files are processed. In Open FTP Push mode, only closed files are processed.
Active file prefix	Becomes active if you select Open FTP transport . It is the prefix of the active AMA DIRP files. This prefix should match the prefix setting on the MSC SDM.
Active file suffix	Becomes active if you select Open FTP Push . It is the suffix of the active AMA DIRP files. This suffix should match the suffix setting on the MSC SDM.
Closed file prefix	Becomes active if you select Open FTP Push . It is the prefix of the closed AMA DIRP files. This prefix should match the prefix setting on the MSC SDM.

Configuring the NRTT CC Node

The NRTT CC node receives GHOT files from DMS-MSC SDMs.

The NRTT CC node generates an alarm if it has not received any data files from a device for a period of time, or if it has not received any new records in the current active file within the configured period of time. The NRTT CC will clear the alarm when it receives a new input file or a new record. The input stream monitoring functionality can be enabled or disabled via the node configuration window.

To configure the DMS-MSC CC node, configure standard options and the options in the **NRTT CC Node** tab. The **NRTT CC Node** tab includes the same options as the **AMA CC** tab. See "[Configuring the DMS-MSC CC Node](#)".

Creating and Configuring the ASCII DC

Before beginning this procedure, edit the NPL rule file that will be used for this DC. Replace the **str2int** NPL function with the **str2decimal** function in the code fragments with the following syntax:

```
yearInt = str2int(tmpValue);  
DMS MSC (32.005 v3.6.0)
```

This change provides a more targeted range of warnings for date stamps from a device.

Note

This NPL rule file change only applies to customized NPL files and not the default files.

Follow these guidelines when creating and configuring the ASCII DC:

- The output includes information from the Billing Block Header Record, Billing File Transfer In Record, and Billing File Transfer Out Record.
- The leading **f** character is deleted in the following fields:
 - Called number
 - Calling number
 - Calling equipment
 - Calling party
 - Called party
 - Dialed digits
 - MSC number
 - Destination routing address
 - SCP address
 - Group call
- The **Numbering_Plan_Identifier** field is split into four fields, as follows:
 - spare field
 - extension fields
 - type of number
 - number plan indicator

For example, if the value for **Numbering_Plan_Identifier** is **01201**, the **spare field** will be **0**, **extension fields** will be **1**, **type of number** will be **2**, and **number plan indicator** will be **01**.

To create and configure the ASCII DC node, configure the standard file management, FTP, and file retention options.

ASCII DC Output Files

This section explains how multiple occurrences of modules are handled in ASCII output files.

For example, the **Supplementary Service Module** can appear multiple times and contains the following attributes:

- SS_ModuleCode
- SS_SsCode

- SS_SsAction
- SS_DateAndTime
- SS_SsParameters
- SS_ResultIndicator

If a CDR contains 3 SS modules, the output appears as:

Header: *regular_preceding_CDR_attribute_names, SS_ModuleCode, SS_SsCode, SS_SsAction, SS_DateAndTime, SS_SsParameters, SS_ResultIndicator, regular_following_CDR_attribute_names*
Fields: *module_code_number, val1_val2_val3, val1__, val1__val3, _val2_val3, __val3*

The field values are separated with an underscore where the **val1** fields apply to the first SS module instance, the **val2** fields apply to the second SS module instance and the **val3** fields apply to the third SS module instance.

If there is no field value for a module, the output appears as two underscores. For example, **val1__val3**.

If there is no specific value for any of the modules, the output appears as two underscores. For example, **__**.

This information applies to other modules, such as **Location and Channel Information** and **Supplementary Service Action**.

ASCII DC Sample Output

The following is sample output from the ASCII DC with version hiding from GSM 17 to GSM 15:

```
'GsmRecordHeader_GsmCallTypeCode', 'FileName', 'TimeStamp', 'AdditionalInformation', 'AccessNetwork', 'AnswerTime', 'CallDuration', 'CalledEquipment', 'CalledNumber_BcdOrHexString', 'CalledNumber_DmsMscNumberType', 'CalledNumber_NPI_SpareField', 'CalledNumber_NPI_ExtendedField', 'CalledNumber_NPI_TypeOfNumber', 'CalledNumber_NumberingPlanIndicator', 'CalledParty_BcdOrHexString', 'CalledParty_DmsMscNumberType', 'CalledParty_NPI_SpareField', 'CalledParty_NPI_ExtendedField', 'CalledParty_NPI_TypeOfNumber', 'CalledParty_NumberingPlanIndicator', 'CalledSubscriberCategory', 'CallIndicator', 'CallingEquipment', 'CallingNumber_BcdOrHexString', 'CallingNumber_DmsMscNumberType', 'CallingNumber_NPI_SpareField', 'CallingNumber_NPI_ExtendedField', 'CallingNumber_NPI_TypeOfNumber', 'CallingNumber_NumberingPlanIndicator', 'CallingParty_BcdOrHexString', 'CallingParty_DmsMscNumberType', 'CallingParty_NPI_SpareField', 'CallingParty_NPI_ExtendedField', 'CallingParty_NPI_TypeOfNumber', 'CallingParty_NumberingPlanIndicator', 'CallingSubscriberCategory', 'CallForwardIndicator', 'CallReference', 'CauseForTermination', 'CellIdentity', 'ChannelAllocationTime', 'ClassmarkTimeStamp', 'DateAndTime', 'DateAndTimeRelease', 'DateAndTimeSeizure', 'DeliveryTimestamp', 'Diagnostic', 'DialedDigits_BcdOrHexString', 'DialedDigits_DmsMscNumberType', 'DisconnectTime', 'EquipmentIdentity', 'EquipmentType', 'GsmRecordHeader_DmsMscStructureCode', 'GsmRecordHeader_HexadecimalId', 'HalfRateInUse', 'HotBillingIndicator', 'IncomingMeteringClass', 'IncomingRouteGroup', 'IncomingTrunkGroup', 'IncomingTrunkMember', 'LocationAreaCode', 'LogicalNetwork', 'MessageReference', 'MeteringZone', 'MsClassmark', 'MscNumber_BcdOrHexString', 'MscNumber_NPI_SpareField', 'MscNumber_NPI_ExtendedField', 'MscNumber_NPI_TypeOfNumber', 'MscNumber_NumberingPlanIndicator', 'OffAirCallSetup', 'OutgoingMeteringClass', 'OutgoingRouteGroup', 'OutgoingTrunkGroup', 'OutgoingTrunkMember', 'RecordNumber', 'ReleaseTime', 'ResultIndicator', 'RoamingNumber_BcdOrHexString', 'RoamingNumber_DmsMscNumberType', 'RoamingNumber_NPI_SpareField', 'RoamingNumber_NPI_ExtendedField', 'RoamingNumber_NPI_TypeOfNumber', 'RoamingNumber_NumberingPlanIndicator', 'ServiceCenter_BcdOrHexString', 'ServiceCenter_NPI_SpareField', 'ServiceCenter_NPI_ExtendedField', 'ServiceCenter_NPI_TypeOfNumber', 'ServiceCenter_NumberingPlanIndicator', 'SmsResult', 'SmsTimestamp', 'StudyIndicator', 'SupplementaryServiceAction', 'SupplementaryServiceCode', 'SupplementaryServiceParameter', 'TrunkReleaseTime', 'TrunkSeizureIncoming', 'TrunkSeizureOutgoing', 'Auxili
```

Ensure the rule file selection corresponds to the incoming GSM data:

- For incoming GSM 18 data, select the rule file DMS MSC ASN1 GSM 18
- For incoming GSM 17 data, select the rule file DMS MSC ASN1 GSM 17
- For incoming GSM 16 data, select the rule file DMS MSC ASN1 GSM 16
- For incoming GSM 15 data, select the rule file DMS MSC ASN1 GSM 15
- For incoming GSM 13 data, select the rule file DMS MSC ASN1 GSM 13

To create and configure the DMS-MSC ASN.1 DC, configure the standard file management, FTP, and file retention options.

DMS-MSC ASN.1 Sample Output

The DMS-MSC ASN.1 DC outputs data according to the 3GPP 32.005 version 3.6 specification. Below is sample output that has been translated into a readable format.

```

* * * * * Record 1 * * * * *
-----
value CallEventRecord ::= incGatewayRecord : {
  recordType incGatewayRecord,
  calledNumber '912141215130F4'H,
  recordingEntity '912141080200F0'H,
  mscIncomingTKGP tkgpName : "00601",
  seizureTime '0303100616492B0000'H,
  answerTime '0303100616512B0000'H,
  releaseTime '0303100616542B0000'H,
  callDuration 3,
  causeForTerm normalRelease,
  diagnostics manufacturerSpecificCause : {
    identifier { 0 1 2 3 },
    information -- OCTET STRING : '020110'H --
  },
  callReference 20511
}
* * * * * Record 2 * * * * *

DMS MSC (32.005 v3.6.0)
-----
value CallEventRecord ::= mtCallRecord : {
  recordType mtCallRecord,
  servedIMSI '13002241215130F4'H,
  servedMSISDN '912141215130F4'H,
  recordingEntity '912141080200F0'H,
  mscIncomingTKGP tkgpName : "00601",
  basicService teleservice : '11'H,
  seizureTime '0303100616492B0000'H,
  answerTime '0303100616532B0000'H,
  releaseTime '0303100616552B0000'H,
  callDuration 2,
  causeForTerm normalRelease,
  diagnostics manufacturerSpecificCause : {
    identifier { 0 1 2 3 },
    information -- OCTET STRING : '020110'H --
  },
  callReference 20511
}
* * * * * Record 3 * * * * *

```

```

DMS MSC (32.005 v3.6.0)
-----
value CallEventRecord ::= moCallRecord : {
  recordType moCallRecord,
  servedIMSI '13002241215130F4'H,
  calledNumber '912141215130F4'H,
  translatedNumber '912141215130F4'H,
  roamingNumber '912141040351F0'H,
  recordingEntity '912141080200F0'H,
  location {
    locationAreaCode "00000",
    cellIdentifier '0000'H
  },
  basicService teleservice : '11'H,
  answerTime '0303100616512B0000'H,
  releaseTime '0303100616542B0000'H,
  callDuration 3,
  causeForTerm normalRelease,
  diagnostics manufacturerSpecificCause : {
    identifier { 0 1 2 3 },
    information -- OCTET STRING : '020110'H --
  },
  callReference 102415,
  additionalChgInfo {
    chargeIndicator charge
  },
  systemType unknown
}

```

Configuring the JDBC DC Node

Before beginning this procedure, edit the NPL rule file that will be used for this DC. Replace the **str2int** NPL function with the **str2decimal** function in the code fragments with the following syntax:

```

yearInt = str2int(tmpValue);
chown oracle /opt/mslvdblogs

```

This change provides a more targeted range of warnings for date stamps from a device.

Note

This NPL rule file change only applies to customized NPL files and not the default files.

Follow these guidelines when configuring the JDBC DC node:

- The original file name of the binary MSC file that produces the CDR is stored in the database
- All date and time fields stored in the database are in the format: YYYYMMDDhhmmss (year/month/day/hour/minute/seconds)
- For incoming GSM data, the leading **f** character is removed for the following fields:
 - MSC Number field in the Location and Channel Information Module and the Location Only Information Module
 - PreTranslated Called Party Number field in the Generic Address Information Module

- Original Calling Number field in the Generic Address Information Module
- Timestamp format in fields TrunkSeizureOutgoing and TrunkSeizureIncoming
- Called number
- Calling number
- Calling equipment
- Calling party
- Called party
- Dialed digits
- MSC number
- Destination routing address
- SCP address
- Group call
- The **Numbering_Plan_Identifier** field is split into four fields, as follows:
 - spare field
 - extension fields
 - type of number
 - number plan indicator

For example, if the value for **Numbering_Plan_Identifier** is **01201**, the **spare field** will be **0**, **extension fields** will be **1**, **type of number** will be **2**, and **number plan indicator** will be **01**.

Creating and Configuring the DMS-MSC AMA DIRP DC

To create and configure the DMS-MSC AMA DIRP DC node, configure the standard file management and FTP options, and the nodes in the tabs described below.

On the **Compression** tab, select **NONE** for no compression, or **zip** or **gzip** for compression. If you archive or delete files, this option compresses them before archiving or deleting them.

Note

When you enable compression, existing files in the output folder will not be archived or deleted after a compression option is selected. As a result, they should be archived or deleted manually.

[Table 12-2](#) shows the options to configure in the **File Matching** tab.

Table 12-2 File Matching Tab

Field	Description
Generate File Based on Input file	Creates only one output file for one AMA file received by the CC node.
Output Directory	Location of the output files.

Table 12-2 (Cont.) File Matching Tab

Field	Description
Bad File Directory	Location of files with errors output from the DC node.
File Prefix	Prefix of the output file. The default value is U . Multiple characters can be used in the prefix. A cannot be used as a prefix since it is reserved for currently written files.
File Suffix	Should match the suffix setting on the MSC SDM.

[Table 12-3](#) shows the options to configure in the **Office Identification** tab.

Table 12-3 Office Identification Tab

Field	Description
Sensor Type	Type of switching equipment from which record information is received. <ul style="list-style-type: none"> • 001 = MSC • 008 = 5ESS (OSPS) • 011 = TSPS-SPC • 029 = DMS-10 • 031 = TSPS-3B • 036 = DMS-100F (DMS-200/TOPS)
Sensor Identification	Individual switch type. The ID is assigned by the operating company. Default is 0000000 .
Recording Office Type	Type of recording machine that produced this record. <ul style="list-style-type: none"> • 001 = MSC • 008 = 5ESS (OSPS) • 011 = TSPS-SPC • 029 = DMS-10 • 031 = TSPS-3B • 32 = AT&T KS (IBM Series 1) AMATPS collector • 036 = DMS-100F (DMS-200/TOPS) • 200 = Telescience collector • 220 = Teltone AMATPS collector • 270 = AT&T Billdats 3B20 AMATPS collector • 271 = AT&T Billdats 3B5 AMATPS collector
Recording Office ID	Individual recording machine. The ID is assigned by the operating company. Default is 0000000 .
Rotation Time	Time, in seconds, for the AMA DC to close an output file and open a new output file. Rotation time is 60 seconds (1 min) by default, which means the DC closes the file within a minute. If there is no data for this period, the DC does not keep the output file unless the Keep Empty File checkbox is selected.
Output Extension	Suffix applied to the file produced by the AMA DC.
Output Directory	Directory path to the location where Offline Mediation Controller stores the files produced by the DC. Default is /tmp .
Keep Empty File	Select this checkbox if you want the node to keep the empty file.
Generate FTOR	Select this checkbox if you want the node to add the File Transfer Out Record parameter to the AMA output file.

Configuring the DMS-MSC NRTT DC Node

To create and configure the DMS-MSC NRTT DC, configure standard options and the options in the tabs described below.

[Table 12-4](#) shows the options to configure in the **Office Identification** tab.

Table 12-4 Office Identification Tab

Field	Description
Sensor Type	Type of switching equipment from which record information is received. <ul style="list-style-type: none"> • 001 = MSC • 008 = 5ESS (OSPS) • 011 = TSPS-SPC • 029 = DMS-10 • 031 = TSPS-3B • 036 = DMS-100F (DMS-200/TOPS)
Sensor Identification	Individual switch type. The ID is assigned by the operating company. Default is 0000000.
Recording Office Type	Type of recording machine that produced this record. <ul style="list-style-type: none"> • 001 = MSC • 008 = 5ESS (OSPS) • 011 = TSPS-SPC • 029 = DMS-10 • 031 = TSPS-3B • 32 = AT&T KS (IBM Series 1) AMATPS collector • 036 = DMS-100F (DMS-200/TOPS) • 200 = Telescience collector • 220 = Teltone AMATPS collector • 270 = AT&T Billdats 3B20 AMATPS collector • 271 = AT&T Billdats 3B5 AMATPS collector
Recording Office ID	Individual recording machine. The ID is assigned by the operating company. Default is 0000000.
Rotation Time	Time, in seconds, for the NRTT DC to close an output file and open a new output file. Rotation time is 60 seconds (1 minute) by default, which means the DC closes the file within a minute.
Maximum AMA Blocks	Maximum number of AMA blocks in one file - minimum of two blocks.

[Table 12-5](#) shows the options to configure in the **NRTT** tab.

Table 12-5 NRTT Tab

Field	Description
Billing Centre Host	The name or IP address of the billing centre server the node sends data to.
Billing Centre Port	The port on the billing centre server that the node uses to communicate with the server.

Table 12-5 (Cont.) NRTT Tab

Field	Description
Billing Centre ACK Timeout	The time, in seconds, the DC waits for the Billing Centre to acknowledge it has received the end of the file. If the DC does not receive an acknowledgment from the Billing Centre that it has received the end of the file, it attempts to resend the file after the interval set in Resend File Timeout .
Resend File Timeout	A timer that is needed to fix a limitation of the Sun Java socket class. The limitation is that when the process tries to send a packet but the network cable on the billing centre is disconnected, the sending method is blocked for several minutes before it realizes that loss of connection. In this case, the node will be blocked and will remain idle until the sending method is returned or until the timer expires - in this case the node will raise alarm to indicate a loss of connection to the billing centre. After that, the node will continue to process and store the data on the local disk. When the Rotation Time or the Max AMA Blocks value expires, whichever one occurs first, the node opens a new connection. It then attempts to resend the entire stored file. When configuring the timer, be aware that the node will automatically interrupt the current sending action if the billing centre does not receive the packet before the timer expires. Do not set the timer too low, otherwise the node will prematurely interrupt the sending of the current packets.
MSC Name	The name of the MSC device. This field value is five characters long and must be the same in the NRTT CC, DMS-MSC NRTT DC and DMS-MSC Active GHOT NRTT DC configurations. Contact your Billing Centre administrator to determine the field value expected by the billing system.
NM Version	The version of the Offline Mediation Controller software. This value must be five characters long.

Configuring the DMS-MSC Active GHOT NRTT DC Node

To configure the DMS-MSC Active GHOT NRTT DC node, configure the standard options, and the options in the **Office Identification** and **NRTT** tabs. For information, see "[Configuring the DMS-MSC NRTT DC Node](#)".

Configuring the Node Chains

You can configure the following node chains:

- [G-CDR Collection with AMA DIRP File Distribution](#)
- [G-CDR Collection with NRTT Distribution](#)
- [G-CDR and GHOT Collection with AMA DIRP File Distribution](#)
- [G-CDR Collection with AMA DIRP Distribution, GHOT Collection with NRTT Distribution, No Recovery](#)
- [G-CDR and GHOT Collection with ASCII File and Database Distribution](#)
- [G-CDR Collection with AMA DIRP Distribution, GHOT Collection with NRTT Distribution, No Recovery](#)

- [G-CDR Collection with AMA DIRP Distribution, GHOT Collection with NRTT Distribution, Recovery](#)
- [G-CDR and GHOT Collection with ASCII File and Database Distribution](#)

G-CDR Collection with AMA DIRP File Distribution

To configure a chain for **G-CDR** collection with **AMA DIRP** file distribution, you configure a DMS-MSC CC node and a DMS-MSC AMA DIRP DC node, and connect the two nodes using multicast routing.

You must configure the DMS-MSC SDM to send the unprocessed files to this CC. When configuring the **G-CDR** stream, ensure you configure the DMS-MSC SDM to send files to the configuration input directory on the DMS-MSC CC node for this stream. In the DMS-MSC CC node configuration, on the AMA CC tab, the **Input Directory** value should match the setting on the DMS-MSC SDM.

In the node configuration window, on the AMA CC tab, select **FTP Push**.

The AMA DIRP DC node can be configured to write all Network Accounting Records (NAR) from one input file to one output file. This one-to-one (1:1) matching applies to GSM version hiding as well.

To activate the file matching feature, click on the File Matching tab in the configuration window and check the **Generate File Based on Input File**.

[Table 12-6](#) lists the instances where 1-to-1 file matching is supported when the appropriate 1:1 NPL rule file is chosen:

Table 12-6 Instances Supporting 1-to-1 File Matching

In: AMA DIRP	Out: AMA DIRP
GSM 18	GSM 18
GSM 18	GSM 16
GSM 16	GSM 16
GSM 16	GSM 15
GSM 15	GSM 15

G-CDR Collection with NRTT Distribution

To configure a chain for **G-CDR** collection with **NRTT** distribution, you must create and configure a DMS-MSC CC node and a DMS-MSC NRTT DC node, and connect the two nodes using multicast routing.

You must configure the DMS-MSC SDM to send the unprocessed files to this CC. When configuring the **G-CDR** stream, ensure you configure the DMS-MSC SDM to send files to the configuration input directory on the DMS-MSC CC node for this stream. In the DMS-MSC CC node configuration window, on the AMA CC tab, the **Input Directory** value should match the setting on the DMS-MSC SDM.

In the node configuration window, on the AMA CC tab, select **FTP Push**.

G-CDR and GHOT Collection with AMA DIRP File Distribution

This node chain contains three streams - one for processing **G-CDR** files, one for processing closed **GHOT** files and one for processing active GHOT files.

To configure a stream for **G-CDR** collection with **AMA DIRP** file distribution, you must configure the DMS-MSC SDM to send files to the configuration input directory on the DMS-MSC CC node for this stream. In the DMS-MSC CC node configuration window, on the AMA CC tab, the Input Directory value should match the setting on the DMS-MSC SDM. On the DMS-MSC CC node configuration window, on the AMA CC tab, select **FTP Push**.

To configure a stream for processing **GHOT** unprocessed files with **AMA DIRP** file distribution, you must configure the DMS-MSC SDM to send files to a different directory than the one provisioned for the G-CDR stream. In the DMS-MSC CC node configuration window, on the AMA CC tab, the Input Directory value should match the setting on the DMS-MSC SDM. On the DMS-MSC CC node configuration window, on the AMA CC tab, select **OpenFTP Push**. Connect the DMS-MSC CC to the DMS-MSC AMA DIRP DC using multicast routing.

To configure a stream for processing **GHOT** active files with **AMA DIRP** file distribution, on the NRTT CC node configuration window, on the NRTT CC Node tab, the **Input directory** value should match the setting on the DMS-MSC SDM. Configure the DMS-MSC SDM to send files to the same directory as the one provisioned for the stream to process closed GHOT files. Connect the NRTT CC node to the DMS-MSC AMA DIRP DC node using multicast routing.

G-CDR Collection with AMA DIRP Distribution, GHOT Collection with NRTT Distribution, No Recovery

This node chain contains three streams - one for processing **G-CDR** files, one for processing closed **GHOT** files and one for processing active GHOT files.

To configure a stream for **G-CDR** collection with **AMA DIRP** file distribution, you must configure the DMS-MSC SDM to send files to the configuration input directory on the DMS-MSC CC for this stream. In the DMS-MSC CC node configuration window, on the AMA CC tab, the Input Directory value should match the setting on the DMS-MSC SDM. On the DMS-MSC CC node configuration window, on the AMA CC tab, select **FTP Push**.

To configure a stream for processing **GHOT** unprocessed files with **NRTT** distribution, you must configure the DMS-MSC SDM to send files to a different directory than the one provisioned for the G-CDR stream. In the DMS-MSC CC node configuration window, on the AMA CC tab, the Input Directory value should match the setting on the DMS-MSC SDM. On the DMS-MSC CC node configuration window, on the AMA CC tab, select **OpenFTP Push**. Connect the DMS-MSC CC to the DMS-MSC NRTT DC node using multicast routing.

To configure a stream for processing **GHOT** active files with **NRTT** distribution, on the NRTT CC node configuration window, on the NRTT CC Node tab, the **Input directory** value should match the setting on the DMS-MSC SDM. Configure the DMS-MSC SDM to send files to the same directory as the one provisioned for the stream to process closed GHOT files. Connect the NRTT CC node to the DMS-MSC NRTT DC node by using multicast routing.

G-CDR Collection with AMA DIRP Distribution, GHOT Collection with NRTT Distribution, Recovery

This node chain contains three streams - one for processing G-CDR files, one for processing closed GHOT files and one for processing active GHOT files.

To configure a stream for **G-CDR** collection with **AMA DIRP** file distribution, you must configure the DMS-MSC SDM to send files to the configuration input directory on the DMS-MSC CC node for this stream. In the DMS-MSC CC node configuration window, on the AMA CC tab, the Input Directory value should match the setting on the DMS-MSC SDM. On the DMS-MSC CC node configuration window, on the AMA CC tab, select **FTP Push**.

The DMS-MSC CC node to DMS-MSC NRTT DC node portion of the node chain processes Closed GHOT files and sends the data to the **buffered** port of the Hot Billing Centre.

The NRTT CC node to DMS-MSC Active GHOT NRTT DC node portion of the node chain processes Active GHOT files and sends the data to the **active** port of the Hot Billing Centre.

You should configure the two **GHOT** streams if you want a stream to handle active data and a recovery stream to handle data when there is a loss of connectivity with the HOT Billing Centre. You can configure the two GHOT streams to output data to the same HOT Billing Centre server, or to different ones.

Configuration rules for the GHOT streams

1. In the **GHOT** streams, configure both the NRTT CC node and the DMS-MSC CC node to have the same input directory, to ensure the NRTT CC node only processes the active files and the DMS-MSC CC node only processes the closed files.

Ensure you configure the DMS-MSC SDM to send files to a different directory than the one provisioned for the G-CDR stream. In the DMS-MSC CC node configuration window - on the AMA CC tab, and in the NRTT CC node configuration window - on the NRTT CC tab, the **Input Directory** value should match the setting on the DMS-MSC SDM.

2. To configure a recovery stream for **GHOT unprocessed** file collection, you must configure the DMS-MSC CC node to collect and process only the closed files. In the CC node configuration window, on the AMA CC tab, select **Open FTP Push**.
3. Use **Multicast** routing to connect the NRTT CC node to the DMS-MSC Active GHOT NRTT DC node.
4. When starting the **GHOT** streams, start both DC nodes first, then start the CC nodes. When stopping the GHOT streams, stop the CC nodes first, then stop the DC nodes.

G-CDR and GHOT Collection with ASCII File and Database Distribution

This node chain contains multiple streams to process **G-CDR** files, closed **GHOT** files and active **GHOT** files.

To configure a stream for **G-CDR** collection with **ASCII** file distribution, you must configure the DMS-MSC SDM to send files to the configuration input directory on the DMS-MSC CC node for this stream. In the DMS-MSC CC node configuration window, on the AMA CC tab, the Input Directory value should match the setting on the DMS-MSC SDM.

On the DMS-MSC CC node configuration window, on the AMA CC tab, select **FTP Push**. Connect the DMS-MSC CC node to the ASCII DC node using multicast routing.

To configure a stream for processing **GHOT** unprocessed files with **ASCII** distribution, you must configure the DMS-MSC SDM to send files to a different directory than the one provisioned for the **G-CDR** stream. In the DMS-MSC CC node configuration window, on the AMA CC tab, the Input Directory value should match the setting on the DMS-MSC SDM. On the DMS-MSC CC node configuration window, on the AMA CC tab, select **Open FTP Push**. Connect the DMS-MSC CC node to the ASCII DC node using multicast routing.

To configure a stream for processing **GHOT** active files with **ASCII** distribution, on the NRTT CC node configuration window, on the NRTT CC Node tab, the Input directory value should match the setting on the DMS-MSC SDM. Configure the DMS-MSC SDM to send files to the

same directory as the one provisioned for the stream to process closed **GHOT** files. Connect the NRTT CC to the ASCII DC using multicast routing.

To configure a stream for **G-CDR** collection with **Database** distribution, you must configure the DMS-MSC SDM to send files to the configuration input directory on the DMS-MSC CC node for this stream. In the DMS-MSC CC node configuration window, on the AMA CC tab, the Input Directory value should match the setting on the DMS-MSC SDM. On the DMS-MSC CC node configuration window, on the AMA CC tab, select **FTP Push**. Connect the DMS-MSC CC node to the Database Storage and Reporting DC using multicast routing.

To configure a stream for processing **GHOT** unprocessed files with JDBC distribution, you must configure the DMS-MSC SDM to send files to a different directory than the one provisioned for the **G-CDR** stream. In the DMS-MSC CC node configuration window, on the AMA CC tab, the Input Directory value should match the setting on the DMS-MSC SDM. On the DMS-MSC CC node configuration window, on the AMA CC tab, select **Open FTP Push**. Connect the DMS-MSC CC node to the Database Storage and Reporting DC using multicast routing.

To configure a stream for processing **GHOT** active files with **Database** distribution, in the NRTT CC node configuration window, on the NRTT CC Node tab, the Input directory value should match the setting on the DMS-MSC SDM. Configure the DMS-MSC SDM to send files to the same directory as the one provisioned for the stream to process closed **GHOT** files. Connect the NRTT CC node to the Database Storage and Reporting DC using multicast routing.

Invalid AMA Input File

When there is invalid data in the AMA input file, the CC raises a critical alarm and information about the error type and location are written to an error file. The AMA input file is then moved to the configured "bad file" directory.

There are three types of invalid data:

1. **Invalid Block Descriptor Word (BDW)**: this error occurs when the block size does not match the content of the block. When the CC detects this error, the remaining information in the file is no longer readable. In this case, the CC processes the AMA DIRP file up to the position where the error was detected.

The CC cannot process the remainder of the file and will output the following alarm:

```
"Critical; Invalid Data; Invalid input data; An error occurred while processing file filename, a copy of this file has been placed in OMC_Home/amadirpei/2s4dgk-99f-e00sohaf/badAmaFilesDir: Error detected in the AMA DIRP file structure at offset_number(block no: block_number, record no:record_number) Invalid Block Descriptor Word"
```

An error report file will be created in the node's configured bad file directory. The name of the error report file has the format *AMA_DIRP_closed_filename_error_report.txt*. The error report identifies the position of the BDW error.

2. **Invalid Record Descriptor Word (RDW)**: this error occurs when the record size does not match the content of the record. When the CC detects this error, the remaining information in the file is no longer readable. In this case, the CC processes the AMA DIRP file up to the position where the error was detected.

The CC cannot process the remainder of the file and will output the following alarm:

```
"Critical; Invalid Data; Invalid input data; An error occurred while processing file filename, a copy of this file has been placed in OMC_Home/amadirpei/2s4dgk-99f-00sohaf/badAmaFilesDir: Error detected in the AMA DIRP file structure at offset:"
```

offset_number(**block no: *block_number*, record no:*record_number***) Invalid Record Descriptor Word"

An error report file will be created in the node's configured "bad file" directory. The name of the error report file has the format *AMA_DIRP_closed_filename_error_report.txt*. The error report identifies the position of the RDW error.

- 3. An error within an AMA record:** for example, an unknown module code index. When the CC detects this error, it stops processing the record. The remaining information in the AMA DIRP file is still reliable, so the CC continues processing, starting with the next AMA record.

The CC outputs the following alarm:

```
"Critical; Invalid Data; Invalid input data; An error occurred while processing file
<filename>, a copy of this file has been placed in OMC_Home/amadirpei/
2s4dgk-99f-00sohaf/badAmaFilesDir: Unable to process the AMA record at block:
block_number, record number: record_number, fileOffset: offset_number, recordSize:
record_sizeerror_specific_information"
```

An error report file will be created in the node's configured "bad file" directory. The name of the error report file has the format *AMA_DIRP_closed_filename_error_report.txt*. The error report identifies the position(s) of the invalid data error.

Error Handling in 1:1 File Matching Situations

The following behaviors explain how errors are handled in various 1:1 file matching situations.

Scenario 1 - Input AMA file is corrupted

1. If the FTIR is corrupted or missing from an input file, the CC will continue to process the rest of the file.

The DC will:

- a. Generate an output file.
- b. Create a copy of this file and place it in the Bad File directory (configured in the DC).
- c. Raise an alarm. For example:

```
Major
Invalid Data; Missing mandatory data; FTIR is missing in the file
U021031154105gcdr. A copy of this file is created in badfile directory
configured in the Node.
```

2. If the file header/first block descriptor word is corrupted, the CC will move the corrupted file to the Bad File directory (configured in the CC). An alarm will be raised by the CC and there will be no output from the DC for this corrupted file as there is no records received from CC. See "[Invalid AMA Input File](#)".
3. If any record other than the FTIR is corrupted, the CC will move the corrupted file to the Bad File directory (configured in the CC). An alarm will be raised. See "[Invalid AMA Input File](#)".

The DC will:

- a. Generate an output file.
- b. Create a copy of this file and place it in the Bad File directory (configured in the DC).

- c. Raise an alarm. For example:

```
Major
Invalid Data; Missing mandatory data; There might be loss of data.
Record Count is not matching with FTOR in the file U021031154105gcdr. A
copy of this file is created in badfile directory configured in the
Node.
```

4. If the AMA record count contained in the FTOR does not match the number of records received, the DC will:

- a. Generate an output file.
- b. Create a copy of this file and place it in the Bad File directory (configured in the DC).
- c. Raise an alarm. For example:

```
Major
Invalid Data; Missing mandatory data; There might be loss of data.
Record Count is not matching with FTOR in the file U021031154105gcdr. A
copy of this file is created in badfile directory configured in the
Node.
```

5. If the FTOR is not received for a particular file (it is decided if records of next input file is received when waiting for FTOR of current file), the DC will:

- a. Generate an output file.
- b. Create a copy of this file and place it in the Bad File directory (configured in the DC).
- c. Raise an alarm. For example:

```
Major
Invalid Data; Missing mandatory data; FTOR is missing in the file
U031118200303. A copy of this file is created in badfile directory
configured in the Node.
```

Scenario 2 - NAR data corruption within the cartridge chain

If the NAR data is corrupted:

1. NAR are written to the **.badarch** file in the scratch directory of that cartridge.
2. All valid NARs prior to the corrupted NAR will be transmitted to the DC.

In this instance, the DC will:

- a. Generate an output file.
- b. Create a copy of this file and place it in the Bad File directory (configured in the DC).
- c. Raise an alarm. For example:

```
Major
Invalid Data; Missing mandatory data; There might be loss of data.
Record Count is not matching with FTOR in the file U021031154105gcdr. A
copy of this file is created in badfile directory configured in the
Node.
```

Database Storage and Reporting

The Database Storage and Reporting functionality allows you to configure DMS-MSC node chains that can process and distribute data to both a billing system and an Oracle 19c database.

The Database Storage solution lets you configure DMS-MSC node chains that process and distribute data to both a billing system and an Oracle 19c database.

[Figure 12-4](#) shows the recommended configuration of the Database Storage node chain. The DMS-MSC CC collects data from DMS-MSC network devices and passes the data to both the DMS-MSC AMA DIRP DC and the JDBC DC. The DMS-MSC AMA DIRP DC sends the data to a billing system. The JDBC DC sends the data to an Oracle 19c database.

Figure 12-4 Database Storage Architecture

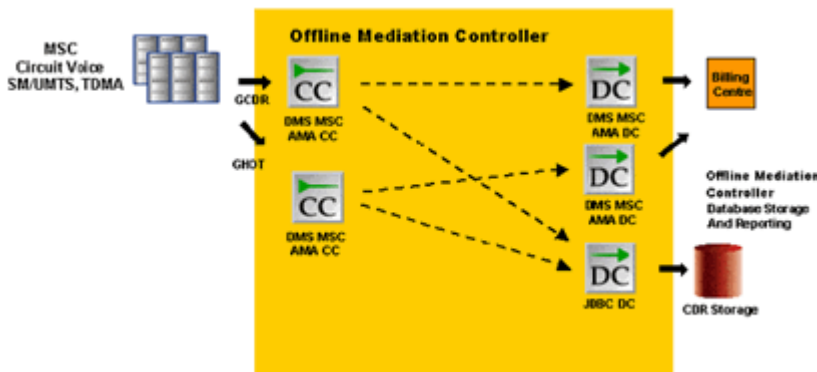

The Repository Manager is a Offline Mediation Controller tool that runs on an Oracle server and can import and export CDRs from an Oracle 19c Enterprise database. You can configure the Repository Manager to export CDRs at a specific time and store them in an accessible way, such as on Digital Audio Tape (DAT) or Digital Linear Tape (DLT). The Repository Manager can import the archived CDRs at a later date, if necessary. You can also configure the Repository Manager to delete CDRs from the database at the same time every day, if you do not wish to archive them.

The Oracle database stores call records it receives from the JDBC DC. The database stores each CDR it receives as a separate record in a table. You can access and modify the CDRs with standard SQL commands.

Offline Mediation Controller supports Oracle 19c Enterprise Edition.

For more information, see the following Oracle 19c documentation:

- *Oracle 19c Installation Guide*
- *Oracle 19c Administrator's Reference*
- *Oracle 19c Real Application Clusters Guard I Configuration Guide*

Installing and Configuring Oracle Database Components

The Database Storage tasks are as follows:

- Creating an Oracle user and dba group
- Installing Oracle
- Verifying the Oracle installation
- Loading the Offline Mediation Controller schema
- Configuring Oracle
- Configuring Linux executables
- Configuring and using the Repository Manager
- Installing the Oracle Client
- Modifying tnsnames.ora
- Installing the Oracle JDBC driver
- Configuring Oracle for automatic restart
- Verifying the Oracle automatic restart

Oracle Database Installation Summary

To install Oracle database, you need to:

Create an Oracle user and dba group. See Oracle 19c documentation.

1. Run the Oracle database installation tool, select components and install. See Oracle 19c documentation.
2. Verify the Oracle database installation. See Oracle 19c documentation.
3. Load the Offline Mediation Controller schema files.
4. Install the Oracle Client.
5. Download and install the Oracle JDBC driver.

See the Oracle database documentation for more information.

The Oracle database components require upgrading if the Database Storage and Reporting functionality is configured.

Upgrading If AMA 1.4.x Cartridge Packs Were Installed

Upgrade the database components if you were running an AMA 1.4.x cartridge pack before you installed the new AMA cartridge pack:

1. As the Oracle user, run the Oracle Enterprise Manager by typing **oemapp worksheet** and pressing **Enter**.
2. Select connect directly to database.
3. For Username, type **NMUSER1**.
4. For Password, type **NMUSER1**.
5. For Service, type **NMCDRS**.
6. For Connect, type **normal**.
7. Click **OK**.

You are now connected to the NMCDRS schema.

8. Stop the Repository Manager using the command:

```
EXEC NMUSER1.MSLV_STOP_REPOMAN
```

9. Navigate to the *OMC_Home/db_scripts/dbstorage/Oracle9i/Upgrade/* directory where you un-jarred the AMA jar file.
10. If you have a GSM 1.0.4 cartridge pack installed, go to next step; otherwise, go to Step 12.
11. Load **Upgrade_From_AMA14_GSMR104.sql**.
12. Load **Upgrade_From_AMA14.sql**.
13. Navigate to the *OMC_Home/db_scripts/dbstorage/Oracle9i/Repoman/* directory where you un-jarred the AMA jar file.
14. Load **PLSQL_NMCDRS_PKG.sql**.
15. Load **PLSQL_LOGTOFILE.sql**.
16. Load **JAVA_UTIL.sql**.
17. Load **PLSQL_RUN_CMD.sql**.
18. Load **PLSQL_RC.sql**.
19. Load **PLSQL_PARFILEWRITER.sql**.
20. Load **PLSQL_BUILD_EXCHANGE.sql**.
21. Load **PLSQL_DROP_PARTITIONS.sql**.
22. Load **PLSQL_BUILD_PARTITIONS.sql**.
23. Load **PLSQL_MSLV_START_REPOMAN.sql**.
24. Load **PLSQL_MSLV_STOP_REPOMAN.sql**.
25. The repoman_configuration table has three new columns. Change the values of the fields in these columns to the appropriate values. These columns are as follows:
 - a. TABLENAME - 1 to 24 bytes. This is the name of the base table (for example **MSLV_ENHCDR_STORAGE**).
 - b. NO_DATAFILES_PER_TS -1 to *n*. This is the number of data files that the tablespace will deploy and should always be set to **1** (unless you desire more as in the case of CHT).
 - c. TBLSPC_NAME - 1 to 10 bytes. This is the base portion of the tablespace name (for example **MSLV_**). The rest will be filled in by appending a datestamp to the end (for example **MSLV_20061219**).

Note

TBLSPC_SIZE has been renamed to DATAFILE_SIZE; as a result, the values for DATAFILE_SIZE have to be re-entered.

26. Start the Repository Manager using the following command.

```
EXEC NMUSER1.MSLV_START_REPOMAN(N);
```

where *N* is the config_num configured in REPOMAN_CONFIGURATION

Upgrading If AMA 4.0.0 to 4.0.7 Cartridge Packs Were Installed

Upgrade the database components if you were running an AMA 4.0.0 to AMA 4.0.7 cartridge pack before you installed the new AMA cartridge pack.

1. As the Oracle user, run the Oracle Enterprise Manager by typing **oemapp worksheet** and pressing **Enter**.
2. Select connect directly to database.
3. For Username, type **NMUSER1**.
4. For Password, type **NMUSER1**.
5. For Service, type **NMCDRS**.
6. For Connect, type **normal**.
7. Click **OK**.
You are now connected to the NMCDRS schema.
8. Stop the Repository Manager using the command:

```
EXEC NMUSER1.MSLV_STOP_REPOMAN
```
9. Navigate to the *OMC_Home/db_scripts/dbstorage/Oracle9i/Upgrade/* directory where you un-jarred the AMA jar file.
10. Load **Upgrade_From_AMA40.sql**.
11. Navigate to the *OMC_Home/db_scripts/dbstorage/Oracle9i/Repoman/* directory where you un-jarred the AMA jar file.
12. Load **PLSQL_NMCDRS_PKG.sql**.
13. Load **PLSQL_LOGTOFILE.sql**.
14. Load **JAVA_UTIL.sql**.
15. Load **PLSQL_RUN_CMD.sql**.
16. Load **PLSQL_RC.sql**.
17. Load **PLSQL_PARFILEWRITER.sql**.
18. Load **PLSQL_BUILD_EXCHANGE.sql**.
19. Load **PLSQL_DROP_PARTITIONS.sql**.
20. Load **PLSQL_BUILD_PARTITIONS.sql**.
21. Load **PLSQL_MSLV_START_REPOMAN.sql**.
22. Load **PLSQL_MSLV_STOP_REPOMAN.sql**.
23. The **repoman_configuration** table has three new columns. Change the values of the fields in these columns to the appropriate values. These columns are as follows:
 - a. **TABLENAME** - 1 to 24 bytes. This is the name of the base table (for example **MSLV_ENHCDR_STORAGE**).
 - b. **NO_DATAFILES_PER_TS** -1 to *n*. This is the number of data files that the tablespace will deploy and should always be set to **1** (unless you desire more as in the case of CHT).
 - c. **TBLSPC_NAME** - 1 to 10 bytes. This is the base portion of the tablespace name (for example **MSLV_**). The rest will be filled in by appending a datestamp to the end (for example **MSLV_20061219**).

Note

TBLSPC_SIZE has been renamed to DATAFILE_SIZE; as a result, the values for DATAFILE_SIZE have to be re-entered.

24. Start the Repository Manager using the following command.

```
EXEC NMUSER1.MSLV_START_REPOMAN(N);
```

where N is the config_num configured in REPOMAN_CONFIGURATION

Upgrade the Database Portion of AMA 3.5. to 3.5.5 For the Parameter (PAR) File Enhancement

Upgrading the database will allow timestamps to be added to the PAR script file name.

1. Stop the Repository Manager using the command:

```
EXEC NMUSER1.MSLV_STOP_REPOMAN
```

2. Navigate to the *cartridge_pack/dbstorage/Oracle9i/Upgrade/* directory where you un-jarred the AMA jar file.
3. Navigate to the *cartridge_pack/dbstorage/Oracle9i/Repoman/* directory where you un-jarred the AMA jar file.
4. Load **PLSQL_PARFILEWRITER.sql**.
5. Load **PLSQL_DROP_PARTITIONS.sql**.
6. Start the Repository Manager using the below command after verifying configuration values in REPOMAN_CONFIGURATION table.

```
EXEC NMUSER1.MSLV_START_REPOMAN(N);
```

where N is the config_num configured in REPOMAN_CONFIGURATION table

In order to manage disk space usage, you may want to delete the older PAR files at regular intervals. The PAR files are kept in the **/opt/mslvdblogs** directory. Ensure that the current PAR file is not deleted.

Loading the Offline Mediation Controller Schema

Use the following procedure to load the Offline Mediation Controller schema.

To load the schema:

1. As the Oracle user, run the Oracle Enterprise Manager by typing **oemapp worksheet** and pressing **Enter**.
2. Select connect directly to database.
3. For Username, type **system**.
4. For Password, type **oracle**.
5. For Service, type **NMCDRS**.
6. For Connect, type **normal**.
7. Click **OK**.

You are now connected to the NMCDRS schema.

8. Navigate to the *OMC_Home/db_scripts/dbstorage/Oracle9i/* directory where you un-jarred the AMA jar file.
9. As the oracle SYSTEM user, load the following tablespace:

DDL_create_tblspc_ENHNMCDRS_MAIN.sql

This is a default tablespace, and does not store daily CDRs.

10. After loading this script, modify the **DATAFILE** to match the directory structure on the machine where you installed Oracle.

For example: *Oracle_Home/oradata/dbf_filename*

Set the SIZE parameter to a minimum of **10M** (ten megabytes).

11. As the oracle SYSTEM user, load:

DDL_create_usr_NMUSER1.sql

If you run the schema file **NMUSER1.sql** from the AMA jar file, then you do not need to run this script again.

12. Disconnect as the SYSTEM user and connect as NMUSER1. The default password is **NMUSER1**.
13. Navigate to the *OMC_Home/db_scripts/dbstorage/Oracle9i/* directory where you un-jarred the AMA jar file.
14. Load **DDL_create_tbl_MSLV_ENHCDR_STORAGE.sql**.
15. Navigate to the *OMC_Home/db_scripts/dbstorage/Oracle9i/* directory where you un-jarred the AMA jar file and then to **/RepoMan**.
16. Load **DDL_create_tbl_REPOMAN_CONFIGURATION.sql**.
17. Load **PLSQL_NMCDRS_PKG.sql**.
18. Load **PLSQL_LOGTOFILE.sql**.
19. Load **JAVA_UTIL.sql**.
20. Load **PLSQL_RUN_CMD.sql**.
21. Load **PLSQL_RC.sql**.
22. Load **PLSQL_PARFILEWRITER.sql**.
23. Load **PLSQL_BUILD_EXCHANGE.sql**.
24. Load **PLSQL_DROP_PARTITIONS.sql**.
25. Load **PLSQL_BUILD_PARTITIONS.sql**.
26. Load **PLSQL_MSLV_START_REPOMAN.sql**.
27. Load **PLSQL_MSLV_STOP_REPOMAN.sql**.

All required Oracle objects are now loaded into Oracle database.

Changing the Default Oracle Username And Password

To change the default Oracle username and password, you must update the **PLSQL_PARFILEWRITER.sql** file. When you un-jar the file from the cartridge jar file, the script is located at: **/db_scripts/dbstorage/Oracle9i/Repoman**.

To change the user name and password in the script:

1. Open the file **PLSQL_PARFILEWRITER.sql** for editing.
2. Scroll down to line 44, which reads **v_LineUser:='USERID="system/oracle AS SYSDBA"'**;
3. The line currently displays **system** as the username and **oracle** as the password.
4. Replace the user name and password with new information.
5. Save the file and close the editing window.

Configuring Oracle Database

You must configure Oracle database to run the Repository Manager.

To configure Oracle database:

1. From the Linux command line, create a new directory that the oracle user can read and write to.

For example, run the following commands in the order shown and press Enter:

```
mkdir /opt/mslvdblogs  
chmod 777 /opt/mslvdblogs
```

This directory stores the Repository Manager log files and the parameter file for the archive process.

2. You must edit an Oracle database initialization parameter in order for the Repository Manager to function correctly.

Start the Oracle DBA Studio application by logging on to your Oracle server as the oracle user and run the following command:

```
oemapp dbastudio &  
TRANSPORT_TABLESPACE=Y
```

3. Log in with the user ID sys and the password dba, then select SYSDBA from the drop-down list.
4. In the Oracle DBA Studio window, select the NMCDRS database, then select Instance and then Configuration.
5. In the Configuration window, go to the General tab and click All Initialization Parameters.
6. In the Initialization Parameters window, go to the util_file_dir entry and set it to **/opt/mslvdblogs**.

This is the directory where the Repository Manager stores its log files. Ensure the oracle user can access this directory.

7. Click **Apply** to save the changes and then exit the application.
8. Restart the database when the DBA Studio prompts you.
9. Change your connection back to SYSTEM.

Configuring Linux Executable

To configure the Linux executable for the Database Storage system:

1. Determine the path of the oracle user for the Linux **cp** program (file copy utility) by logging on to a Linux session as oracle and run the following command:

```
which cp
```

The system responds with a path such as `/usr/bin/cp`.

- Determine the path of the oracle user for the Linux **exp** program (export utility) by logging on to a Linux session as oracle and run the following command:

```
which exp
```

- The system responds with a path such as `Oracle_Home/bin/exp`.
- Locate **DDL_Java_Permissions.sql** and open the file in a text editor program. Then edit the cp and exp information to match the directory path for your system and save the file.
- Log in to Oracle SQLPlus as the SYSTEM user.
- Load and run the updated **DDL_Java_Permissions.sql** file.

Configuring and Using the Repository Manager

These sections explain how to configure the Repository Manager.

Adding Entries to the Configuration Table

The Repository Manager requires you to provide some configuration data before it can run. You must insert the data into the Repository Manager `NMUSER1.REPOMAN_CONFIGURATION` table.

You can use the table data editor in the Oracle DBA Studio tool to edit the Repository Manager configuration table. Each row in the table represents a configuration and only one configuration is used at a time. You can keep many configurations in the table for testing purposes.

Parameters

The following are the parameters you must configure in the `NMUSER1.REPOMAN_CONFIGURATION` table.

CONFIG_NUM

Set to an integer value such as 1, 2, 3, 4, 5 and so on.

DESCRIPTION

Enter a text description of the configuration up to 80 characters.

RUN_MODE

Set to DELETE or ARCHIVE.

NEXT_PRTN_INTERVAL

This setting controls when the Repository Manager creates the next partition, which is usually once a day.

[Table 12-7](#) lists some examples of the settings and their values.

Table 12-7 Example Settings

Functional setting	NEXT_PRTN_INTERVAL parameter value
Everyday at midnight-12 am	TRUNC(SYSDATE + 1)
Everyday at 8 pm	TRUNC(SYSDATE + 1) + 8/24
Every Tuesday at noon-12 pm	NEXT_DAY(TRUNC(SYSDATE), "TUESDAY") + 12/24

Table 12-7 (Cont.) Example Settings

Functional setting	NEXT_PRTN_INTERVAL parameter value
First day of the month at midnight	TRUNC(LAST_DAY(SYSDATE) + 1)
Last day of the quarter at 11 pm	TRUNC(ADD_MONTHS(SYSDATE + 2/24,3), 'Q') - 1/24
Every Monday, Wednesday and Friday at 9 am	TRUNC(LEAST(NEXT_DAY(SYSDATE, "MONDAY"), NEXT_DAY(SYSDATE, "WEDNESDAY"), NEXT_DAY(SYSDATE, "FRIDAY")) + 9/24

For testing purposes, you can configure the Repository Manager to automatically generate new partitions every minute or every five minutes. For every minute, use the value **SYSDATE + 1/1440**. For every five minutes, use the value **SYSDATE + 5/1440**.

DAYS_TO_KEEP

Set to the number of days to keep the CDRs in the database.

TBLSPC_DIRECTORY

This is the directory where Oracle database stores the tablespace data files. The oracle user must have full permissions to this directory. Set this value to the full directory path. For example: **/opt/oradata/mydatadisk/**

TBLSPC_SIZE

This is the size of each tablespace the Repository Manager generates. As a minimum, set the value to the maximum amount of data stored per day. Use an integer followed by M-megabytes. For example, for a 125 megabyte partition per day, use **125M**.

START_PRTN

This is the date the Repository Manager generates the first partition. For example, to set the first partition on March 14, 2006, set the value to **14-Mar-2006 12:00:00 AM**

Note

The time value is not used.

Before you insert data into the database, ensure a partition exists with a date that is equal to or ahead of the date on which you are inserting data. For example, if you insert data on October 22, 2006 and the existing partitions have dates previous to October 22, the CDRs are not inserted.

START_AT

This determines when the Repository Manager starts running. Set this value to a time beyond the current time of the Linux system. To avoid setting times in the past, change this value to a time slightly ahead of the current time whenever you run the Repository Manager.

For example, if you set the value to **SYSDATE + 60/1440**, you have one hour to start the Repository Manager.

ARCHIVE_OUT_DIRECTORY

This is the directory where the Repository Manager stores the archive partitions when it is running in archive mode. Ensure the oracle user has full permissions to this directory. Oracle recommends that you periodically send the archive files to a storage tape, such as DLT or DAT, and then delete the archive files from the database.

ORACLE_EXP_PATH and LINUX_CP_PATH

Set these parameters to the directory paths for the Oracle export utility and the Linux file copy utility, as described in Configuring Linux Executable. Enter the directory path but not the executable name. For example, for a Linux file copy utility located in **/usr/bin/**, enter only **/usr/bin/**.

Starting the Repository Manager

From Oracle SQLPlus, log in to the database as nmuser1. Start the Repository Manager with the execute command and the number of the configuration you wish to use. For example, to use configuration 1, run the following command:

```
exec nmuser1.MSLV_START_REPOMAN(1)
```

Stopping the Repository Manager

From Oracle SQLPlus, log in to the database as nmuser1. Stop the Repository Manager with the following command:

```
exec nmuser1.MSLV_STOP_REPOMAN
```

Importing Records with the Repository Manager

You can import archive partitions into the Oracle database. If you import an archive partition into the database that you exported from, ensure the tablespace you are importing does not already exist in the database. This situation can occur if the partition was not exported correctly.

To import an archive partition, do the following:

1. Copy the archive file **MSLV_date_TS.dbf** to the ARCHIVE_OUT_DIRECTORY as specified in the REPOMAN_CONFIGURATION table.
2. Create an import parameter file and ensure the oracle user has read access to this file.

Here is an example of an import parameter file:

```
USERID='sys/TBD AS SYSDBA'  
TABLESPACES=(MSLV_20060123)  
DATAFILES=(/opt/Oracle902/oradata/NMCDRS/MSLV_20060127_TS.dbf)  
FILE='/opt/mslvout/MSLV_DBSR_ARCHIVE_20060127.dmp'
```

where:

- In the USERID field, you can specify any user with SYSDBA privileges. By default, the oracle SYS user has SYSDBA privileges.
 - In the DATAFILES field, specify the path to the **.dbf** file and the **.dmp** file.
3. Save the file. For example, you can save the file as:

```
/my_importfiles/import_date.par  
JDBCUrl
```

4. Import the file using the Oracle import utility by running the following command:

```
imp PARFILE = /my_importfiles/import_date.par
```

5. The import utility loads the file. The import appears as a table called XCHANGE_ date.

Deleting Records with the Repository Manager

The Repository Manager uses a separate Oracle partition in the MSLV_CDR_STORAGE table to store all the CDRs for each day. The Repository Manager generates new partitions daily and deletes old partitions that have existed longer than the value set in the DAYS_TO_KEEP parameter. If you wish to archive the old partitions instead of deleting them, run the Repository Manager in archive mode.

To run the Repository Manager in delete mode, set the RUN_MODE parameter to DELETE in the REPOMAN_CONFIGURATION table.

Archiving Records with the Repository Manager

When the Repository Manager runs in archive mode, it sends old partitions to a storage disk before deleting them from the database.

To run the Repository Manager in archive mode, set the RUN_MODE parameter to ARCHIVE in the REPOMAN_CONFIGURATION table.

The Repository Manager creates a pair of files for each partition, and stores them in the ARCHIVE_OUT_DIRECTORY as specified in the REPOMAN_CONFIGURATION table. For example, for an archive partition from January 21, 2006, the Manager generates two files:

- MSLV_20060121_TS.dbf
- MSLV_DBSR_ARCHIVE_20060121.dmp

The .dbf file is an Oracle data file and the .dmp file is a metadata file that Oracle uses when importing archive partitions into the database. You can use the Oracle Import program, imp, to load archive partitions into the database. These files are only compatible with the Oracle Transportable Tablespaces export and import mode.

Installing the Oracle Client

You must install the Oracle 19c Client to query the database.

See the Oracle Installation Guide for instructions on installing the Oracle Client. Once you have installed the Oracle Client, you can install the Oracle JDBC driver.

Installing the Oracle JDBC Driver

To use the JDBC DC, you must download and install the Oracle JDBC driver.

To install the Oracle JDBC driver:

1. Download the **ojdbc6.jar** file from the following location:
<https://www.oracle.com/database/technologies/appdev/jdbc-downloads.html>
2. On the Offline Mediation Controller server where the Node Manager is running, place the file in the *OMC_home\3rdparty_jars* directory.
3. To configure the JDBC-DC node for RAC environment, use the following URL when you define a new NPL for JDBC-DC node:

```
JDBCdriver "oracle.jdbc.OracleDriver";  
"jdbc:oracle:thin:(DESCRIPTION=(LOAD_BALANCE=on)(ADDRESS=(PROTOCOL=TCP)(HOST=Host1)(PORT=1521))(ADDRESS=(PROTOCOL=TCP)(HOST=Host2)(PORT=1521))(CONNECT_DATA=(SERVICE_NAME=service)))";
```

4. You can now start or restart the Offline Mediation Controller Administration Server, Node Manager, and JDBC DC.

Configuring Oracle Database for Automatic Restart

You can set up Oracle database to automatically restart after the server reboots.

To configure Oracle database to automatically restart:

1. As root, copy the `OMC_home/db_scripts/dbstorage/Oracle9i/dbora.sh` file and paste the `dbora.sh` file on the Oracle database server, in the `/etc/init.d` directory.
2. Ensure that `ORA_Home` is set to the same value as the `ORACLE_home` setting.
3. Enable `NMCDRS` in the `oratab` file by changing the setting of the `/var/opt/oracle/oratab` directory from `N` to `Y`.
4. As root, in the `/etc` directory, edit the services file.

Use the `chmod` command to modify the file permissions. Add the following line for the Oracle listener:

```
listener 1521/tcp #oracle listener
ln -s /etc/init.d/dbora /etc/rc2.d/S99dbora
```

5. To create symbolic links, run the following commands as root:

```
ln -s /etc/init.d/dbora /etc/rc0.d/K10dbora
```
6. Create a PFILE that Oracle reads upon start-up that points to a valid SPFILE. Navigate to the `Oracle_home/dbs` directory. There is an SPFILE called `spfileNMCDRS.ora`. You must create a new file in this directory called `initNMCDRS.ora`.
7. In the new `initNMCDRS.ora` file, add the following line:

```
SPFILE = 'Oracle_Home/dbs/spfileNMCDRS.ora'
ORAENV_ASK=NO ; export ORAENV_ASK
```

8. To set the Oracle profile, as the Oracle user, navigate to the `Oracle_home` directory.
9. Create a file called `.profile` and add:

```
PATH=$HOME/bin:$PATH
ORACLE_SID=NMCDRS ; export ORACLE_SID
. $HOME/bin/oraenv
```

This allows the `dbora` script in `/etc/init.d` to access the correct environment to start the Oracle listener.

Verifying the Oracle Database Automatic Restart

To verify the Oracle database automatic restart:

1. To see the processes that are running, run the following command:

```
ps -ef | grep ora
```
2. As the root user, go to the `/etc/init.d` directory.
3. Run the following command to stop the listener and oracle processes:

```
./dbora stop
```

The listener and oracle processes stop.
4. Run the following command to start the listener and oracle processes:

```
./dbora start
```

The listener and oracle processes start.

Known Problems

This cartridge pack contains the following known problems:

- On the DMS-MSC AMADIRP DC node, if the option "Keep Empty File" is unchecked and there is no CDR data, the file sequence number is erroneously incremented when the cartridge is stopped and restarted.
- Any input or output directory settings in the node configuration windows must be within the same disk partition where Offline Mediation Controller is installed. Failure to do so can result in errors, alarms, and potentially, loss of data.
- On the DMS-MSC AMA DIRP DC node, Office Identification tab, the **Generate FTOR** checkbox (File Transfer Out Record) is supported for GSM 16 only. If you wish to enable this checkbox, ensure a GSM 16 rule file is selected for the node.
- On the DMS-MSC AMA DIRP DC node, File Matching tab, the **Generate File based on input file** checkbox is supported for GSM 18, GSM 16 and GSM 15. If you wish to enable this checkbox, ensure File Matching supported NPL rule file (1TO1_GSM18, 1TO1_GSM16, 1TO1_GSM15) is selected for the node. The following configurations are supported for 1:1 file matching:
 - GSM18 in -> GSM18 out
 - GSM18 in -> GSM16 out
 - GSM16 in -> GSM16 out
 - GSM16 in -> GSM15 out
 - GSM15 in -> GSM15 out

13

Configuring the Real-Time ASCII File Collection CDK Cartridge Pack

This chapter describes how to configure the Oracle Communications Offline Mediation Controller Real-Time ASCII File Collection CDK Cartridge Pack.

Topics in this chapter:

- [About the Real-Time ASCII File Collection Cartridge Development Kit \(CDK\) Cartridge Pack](#)

About the Real-Time ASCII File Collection Cartridge Development Kit (CDK) Cartridge Pack

The Real-Time ASCII File Collection Cartridge Development Kit (CDK) cartridge pack collects ASCII records from files in real-time. This collection cartridge is ideal for collection records from servers which output records into a log file over a long period of time (several hours).

Configuring the SGSN06 Cartridge Pack

This chapter describes how to configure the nodes included in the Oracle Communications Offline Mediation Controller SGSN06 Cartridge Pack.

Topics in this chapter:

- [About the SGSN06 Cartridge Pack](#)
- [Configuring the GTP Prime CC Node](#)
- [Configuring the 3GPP Parsing EP Node](#)
- [Configuring the 3GPP Session Sequencing AP Node](#)
- [Configuring the Session AP Node](#)
- [Configuring the 3GPP ASN.1 DC Node](#)
- [Alarms](#)

About the SGSN06 Cartridge Pack

The SGSN06 cartridge pack supports 3GPP TS 32.298 V6.4.1, 3GPP TS 32.298 7.3.0, and 3GPP TS 32.298 V10.5.0 for SGSN call data records (CDR).

This cartridge pack comprises the following nodes:

- GTP Prime CC
- 3GPP Parsing EP
- Session AP
- 3GPP ASN.1 DC

[Figure 14-1](#) displays the architecture of the solution.

Figure 14-1 Architecture

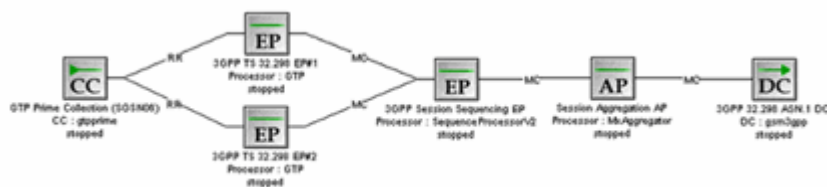

Note

The capability to create the 3GPP Session Sequencing EP is available in the core Offline Mediation Controller product.

Configuring the GTP Prime CC Node

This section describes how to configure the GTP Prime CC Node.

Configuring Input From GPRS Tunneling Protocol

To get input from data sent by using the GPRS Tunneling Protocol (GTP) protocol, you use the GTP Prime CC node. In addition to the General and Destination tabs, you must configure the **GSN Monitor** tab and the **UDP** tab.

[Table 14-1](#) shows the options to configure in the **GSN Monitor** tab.

Table 14-1 GSN Monitor Tab

Field	Description
Enable GSN Monitoring	Select this check box to enable GSN monitoring for this node.
Send Port	Enter the port number the CC node uses to send GTP requests to the GSNs.
CGF IP Address	Select the Charging Gateway Function (CGF) IP Address.
Monitored GSN List	This table contains the GSN devices that send data to the CC node. Use the Add or Delete buttons to make GSN device changes to the table.
Add	Click to add a new GSN device.
Delete	Click to delete an existing GSN device.
IP Address	Enter the IP Address of the GSN device. Note: Internet Protocol version 4 and 6 (IPv4 and IPV6) are supported.
Port	Enter the GSN Port number that sends data to the CC node.
Request Interval (Sec.)	Enter the amount of time, in seconds, between GTP requests.
Response Timer (Sec.)	Enter the amount of time, in seconds, that the CC node waits for a response from the GSN, before re-sending the original request.
Use Node Alive Request	Select this check box to enable the GTP Prime CC node to send a node alive request to the GSN if it has not received any Call Detail Record's (CDR) in a specific interval. You configure this interval in the Request Interval field. If the CC node receives a response from the GSN before the interval expires, it will not generate a warning alarm. (This means that the GSN is functioning correctly and does not have any CDRs for this specific interval). If the CC node does not receive a response from the GSN before the interval expires, it will generate a warning alarm. The CC node will clear this warning alarm when it receives CDRs from the GSN or when the GSN responds to the node alive request.

[Table 14-2](#) shows the options to configure in the **UDP** tab.

Table 14-2 UDP Tab

Field	Description
Port	Enter the port number used to communicate with a database or device. The number must be a positive integer.
Maximum Packet Size	Enter the maximum size for the UDP packet that the CC node will accept.

Configuring the 3GPP Parsing EP Node

To configure the 3GPP Parsing EP Node node, you can specify which encoding rules are used for incoming records, Basic Encoding Rules (BER) or Aligned Packed Encoding Rules (PER). To do so, choose which rules to use in the 3GPP 32.015 Parsing Enhancer EP node **Encoder Type** tab.

Configuring the 3GPP Session Sequencing AP Node

To configure the 3GPP Session Sequencing AP node, you configure standard parameters and the entries in the **Sequencing** tab. [Table 14-3](#) shows the options to configure in the **Sequencing** tab.

Table 14-3 Sequencing Tab

Option	Description
Expiry Interval (minutes)	Enter the time the node waits, before the sequence records output are sent to the next node in the chain.
Session Storage limiting	Select the amount to the Limit field.
Log Duplicate Entries	Select this check box to enable the node to create a log entry for each duplicate record.
Missing Record Monitoring	Select this check box to enable the node to generate alarms or logs for any missing records it detects.
Missing Record Alarm or Log Severity	Select the alarm severity level or log option that the node will generate for a missing record.
Retain Recent Records	Select this check box to enable the node to retain recent records.
Buffer Size	Enter the buffer size required to retain recent records.

Configuring the Session AP Node

To configure the Session AP node, you configure standard aggregation and file management tabs.

Configuring the 3GPP ASN.1 DC Node

To configure the 3GPP ASN.1 DC node, you configure standard parameters, including FTP connection configurations.

[Table 14-4](#) shows the options to configure in the **GSM 3GPP Output** tab.

Table 14-4 GSM 3GPP Output Tab

Field	Description
Output Directory	Enter the directory path and name where Offline Mediation Controller stores the files produced by the DC node.
File Name	Enter the prefix name of the output files.
Current File Extension	Enter the file extension of the preprocessed output file.
Processed File Extension	Enter the file extension of the processed files.
Output Push Time Unit	Select the unit of time in years, months, days, hours, minutes or seconds, that Offline Mediation Controller waits, before closing a file and creating a new file.
Output Push Time Period	Enter the duration of time that Offline Mediation Controller waits, before closing a file and creating a new file. The range is 1 to 2147483647.
Encoding Option	Select which encoding length option is required for the output data.

Alarms

All Offline Mediation Controller alarms are listed in the **alarms.txt** file located in the *OMC_home* directory (*OMC_home* is the directory in which you installed Offline Mediation Controller). No new alarms are introduced in this cartridge pack.

15

Configuring the Syslog Collection Cartridge Pack

This chapter describes how to configure the nodes included in the Oracle Communications Offline Mediation Controller Syslog Collection Cartridge Pack.

Topics in this chapter:

- [About the Syslog Collection Cartridge Pack](#)
- [Configuring the Syslog CC Node](#)
- [Syslog Rotation On AIX 5.3](#)
- [NAR Attributes and Error Scenarios](#)
- [Known Problems](#)

About the Syslog Collection Cartridge Pack

The Syslog Collection Cartridge Pack collects syslog files from multiple devices.

Configuring the Syslog CC Node

To configure the Syslog CC S CC node, you configure standard parameters, include file management and FTP connection configurations.

Syslog Rotation On AIX 5.3

The file `/etc/syslog.conf` contains information used by `syslogd` and the `syslog` daemon process, to forward a system message to appropriate log files or users or both. Since AIX has no `logrotate` daemon running, you must adapt `syslogd` to do the syslog rotation. The format would be

Syntax: `<selector> <action> <rotate_info>`

Example 1:

```
mail.debug /var/log/mail rotate size 100k files 4 # 4 files, 100kB each
```

Example 2:

```
user.debug /var/log/user rotate files 12 time 1h # 12 files, hourly rotate
```

Rotation can be based on size or time or both.

Size: This keyword specifies that rotation is based on size. It is followed by a number and either a k (kilobytes) or m (megabytes).

Time: This keyword specifies that rotation is based on time. It is followed by a number and either a h(hour) or d(day) or w(week) or m(month) or y(year).

NAR Attributes and Error Scenarios

[Table 15-1](#) details the Network Accounting Record (NAR) attributes, as well as potential error scenarios.

Table 15-1 Network Accounting Record Attributes and Potential Errors

NAR ID	Type	Value
facility	string	This field can be blank or contain any of the following values: <ul style="list-style-type: none"> • user • kern • mail • daemon • auth • lpr • news
messageId	string	This field can be blank or contain a numeric value.
filename	string	Input file name.
processName	string	This field can be blank or contain a string value such as sendmail or mountd .
processId	string	This field can be blank or contain a numeric value.
message	string	Syslog message.
date	string	The date as a string value in the format: <i>MMM d HH:mm:ss</i> For example: Dec 2 16:40:50
level	string	This field can be blank or contain any of the following values: <ul style="list-style-type: none"> • emerg • alert • crit • err • warning • notice • info • debug • none
host	string	This field can be an IP address or host name.
nar_errorFlag	integer	A flag that indicates whether any problems were detected while parsing the CDR (0 means that no problems were detected and 1 means that a problem was detected).

The following are potential error situations where the node will skip the record and create a log:

1. If **date** field is not in the format *MMM d HH:mm:ss*.
2. If the **processId** is not a valid numeric value.

3. If there are any missing fields in the input data, such as **date**, **host** or **message**, for example.

The node will create a log with the following format:

```
Invalid Data, File data not as expected, Invalid syslog record in 'filename' file: 'syslog_record'  
This record cannot be processed
```

For example:

```
Invalid Data, File data not as expected, Invalid syslog record in  
'message3.complete' file: '09 26 05:26:36 servcomnetdb25 mountd[5436]: [ID  
882487 daemon.error] unable to create nfsauth service' This record cannot be  
processed
```

Known Problems

The following are known problems for this cartridge pack:

1. In the event of an FTP session failure, the CC node will attempt to re-establish the session every 5 seconds, instead of the configured FTP Interval value on the FTP Settings tab. The CC node will continue to attempt a re-connection until it successfully transfers the file. The CC node will generate a log message for each unsuccessful FTP attempt. If there is a problem with the network or the FTP server, you may want to stop the CC node, fix the problem, and then restart the CC node.
2. When provisioning the local directory where the CC node is to collect files, if the specified directory does not exist, the CC node will raise a critical alarm and will not start.
3. When configuring the prefix and suffix values for the CC node, non-alphanumeric characters, such as . and _ are supported but the # and / characters are not supported. Using these unsupported characters can result in the use of unexpected values when the data files are being renamed.

A

Sample Mapping for ECE Cartridge Pack

This appendix contains the sample mapping for the Oracle Communications Offline Mediation Controller Elastic Charging Engine (ECE) Distribution Cartridge (DC).

Topics in this document:

- [About the Sample Mapping](#)
- [Supported Usage Types](#)
- [Mapping for ASCII](#)
- [Mapping for SGSN](#)
- [Mapping for IMS](#)
- [Mapping for Oracle CDR Format](#)

About the Sample Mapping

The sample mapping includes:

- The input attribute-value pairs (AVPs) in the call detail records (CDRs)
- The values in the ECE payload specification files
- The ECE usage requests and payload parameters Offline Mediation Controller uses to build the usage request to send to ECE

Supported Usage Types

The ECE DC supports the following usage types for offline usage requests:

- Terminate
- Update
- Refund_Unit
- Refund_Amount
- Cancel
- Debit_unit
- Debit_amount

Note

For refund usage types, the input CDR must contain the **correlation_identifier** value of the original debit request.

Mapping for ASCII

By default, the ECE DC supports the following ASCII product types:

- Voice
- Data
- SMS

Voice

Product Type = VOICE

Event Type = USAGE

Usage Type = Terminate

[Table A-1](#) shows the sample ASCII voice mappings for the Terminate usage type.

Table A-1 Sample ASCII Voice Mapping for the Terminate Usage Type

ASCII NPL Fields	ECE Payload Fields	ECE Usage Object Builder Parameter
duration	USED_UNITS[0].DURATION	N/A
CalledId	N/A	CALLED_ID
calling_number	N/A	UserIdentity
session_id	N/A	Session Id
start_time	N/A	Start time
end_time	N/A	End time
seq_no	N/A	Seq number

Product Type = VOICE

Event Type = USAGE

Usage Type = Update

[Table A-2](#) shows the sample ASCII voice mappings for the Update usage type.

Table A-2 Sample ASCII Voice Mapping for the Update Usage Type

ASCII NPL Fields	ECE Payload Fields	ECE Usage Object Builder Parameter
Req_Duration	REQUESTED_UNITS[0].DURATION	N/A
Used_Duration	USED_UNITS[0].DURATION	N/A
CalledId	N/A	CALLED_ID
calling_number	N/A	UserIdentity
session_id	N/A	Session Id
start_time	N/A	Start time
end_time	N/A	End time
seq_no	N/A	Seq number

Product Type = VOICE

Event Type = USAGE

Usage Type = Refund_Unit

[Table A-3](#) shows the sample ASCII voice mappings for the Refund_Unit usage type.

Table A-3 Sample ASCII Voice Mapping for Refund_Unit Usage Type

ASCII NPL Fields	ECE Payload Fields	ECE Usage Object Builder Parameter
Used_duration	USED_UNITS[0].DURATION	N/A
CalledId	N/A	CALLED_ID
calling_number	N/A	UserIdentity
session_id	N/A	Session Id
start_time	N/A	Start time
end_time	N/A	End time
seq_no	N/A	Seq number
correlation_identifier	CORRELATION_IDENTIFIER	N/A

Product Type = VOICE

Event Type = USAGE

Usage Type = Refund_Amount

[Table A-4](#) shows the sample ASCII voice mappings for the Refund_Amount usage type.

Table A-4 Sample ASCII Voice Mapping for the Refund_Amount Usage Type

ASCII NPL Fields	ECE Payload Fields	ECE Usage Object Builder Parameter
CalledId	N/A	CALLED_ID
calling_number	N/A	UserIdentity
session_id	N/A	Session Id
start_time	N/A	Start time
end_time	N/A	End time
seq_no	N/A	Seq number
balance_element_id	IMPACT_AMOUNT[0].BALANCE_ELEMENT_ID	N/A
amount	IMPACT_AMOUNT[0].AMOUNT	N/A
correlation_identifier	CORRELATION_IDENTIFIER	N/A

Data

Product Type = DATA

Event Type = USAGE

Usage Type = Terminate

[Table A-5](#) shows the sample ASCII data mappings for the Terminate usage type.

Table A-5 Sample ASCII Data Mapping for the Terminate Usage Type

ASCII NPL Fields	ECE Payload Fields	ECE Usage Object Builder Parameter
cell_id	CELL_ID	N/A
usedUnitsInputVolume	USED_UNITS[0].INPUT_VOLUME	N/A
usedUnitsOutputVolume	USED_UNITS[0].OUTPUT_VOLUME	N/A
usedUnitsTotalVolume	USED_UNITS[0].TOTAL_VOLUME	N/A
CalledId	N/A	CALLED_ID
calling_number	N/A	UserIdentity
session_id	N/A	Session Id
start_time	N/A	Start time
end_time	N/A	End time
seq_no	N/A	Seq number

Product Type = DATA

Event Type = USAGE

Usage Type = Update

[Table A-6](#) shows the sample ASCII data mappings for the Update usage type.

Table A-6 Sample ASCII Data Mapping for the Update Usage Type

ASCII NPL Fields	ECE Payload Fields	ECE Usage Object Builder Parameter
cell_id	CELL_ID	N/A
requestedInputVolume	REQUESTED_UNITS[0].INPUT_VOLUME	N/A
requestedOutputVolume	REQUESTED_UNITS[0].OUTPUT_VOLUME	N/A
requestedTotalVolume	REQUESTED_UNITS[0].TOTAL_VOLUME	N/A
usedUnitsInputVolume	USED_UNITS[0].INPUT_VOLUME	N/A
usedUnitsOutputVolume	USED_UNITS[0].OUTPUT_VOLUME	N/A
usedUnitsTotalVolume	USED_UNITS[0].TOTAL_VOLUME	N/A
CalledId	N/A	CALLED_ID
calling_number	N/A	UserIdentity
session_id	N/A	Session Id
start_time	N/A	Start time
end_time	N/A	End time
seq_no	N/A	Seq number

Product Type = DATA

Event Type = USAGE

Usage Type = Refund_Unit

[Table A-7](#) shows the sample ASCII data mappings for the Refund_Unit usage type.

Table A-7 Sample ASCII Data Mapping for the Refund_Unit Usage Type

ASCII NPL Fields	ECE Payload Fields	ECE Usage Object Builder Parameter
cell_id	CELL_ID	N/A
usedUnitsInputVolume	USED_UNITS[0].INPUT_VOLUME	N/A
usedUnitsOutputVolume	USED_UNITS[0].OUTPUT_VOLUME	N/A
usedUnitsTotalVolume	USED_UNITS[0].TOTAL_VOLUME	N/A
CalledId	N/A	CALLED_ID
calling_number	N/A	UserIdentity
session_id	N/A	Session Id
start_time	N/A	Start time
end_time	N/A	End time
seq_no	N/A	Seq number
correlation_identifier	CORRELATION_IDENTIFIER	N/A

Product Type = DATA

Event Type = USAGE

Usage Type = Refund_Amount

[Table A-8](#) shows the sample ASCII data mappings for the Refund_Amount usage type.

Table A-8 Sample ASCII Data Mapping for the Refund_Amount Usage Type

ASCII NPL Fields	ECE Payload Fields	ECE Usage Object Builder Parameter
cell_id	CELL_ID	N/A
CalledId	N/A	CALLED_ID
calling_number	N/A	UserIdentity
session_id	N/A	Session Id
start_time	N/A	Start time
end_time	N/A	End time
seq_no	N/A	Seq number
balance_element_id	IMPACT_AMOUNT[0].BALANCE_ELEMENT_ID	N/A
amount	IMPACT_AMOUNT[0].AMOUNT	N/A
correlation_identifier	CORRELATION_IDENTIFIER	N/A

Mapping for SGSN

The ECE DC supports the following SGSN product types:

- Data
- SMS

Data

SGSN PDP Record

[Table A-9](#) shows the sample SGSN data mapping for the PDP record.

Table A-9 Sample SGSN Data Mapping for the SGSN PDP Record

ASN 1 Fields	SGSN Cartridge NPL Fields	ECE Payload Fields	ECE Usage Object Builder Parameter
listOfTrafficVolumes.dataVolumeGPRSUplink	part of 20209	USED_UNITS[0].OUTPUT_VOLUME	N/A
listOfTrafficVolumes.dataVolumeGPRSDownlink	part of 20209	USED_UNITS[0].INPUT_VOLUME	N/A
cellIdentifier	20223(CellIdentifier)	CELL_ID	N/A
servedIMSI	20234 (ServedIMSI)	N/A	UserIdentity
chargingID	20001(ChargingID)	N/A	Session id
recordOpeningTime	N/A	N/A	start time
duration	duration	N/A	end_time(calculated from the duration)
recordSequenceNumber	20005 (record sequence number)	N/A	sequence number

S-GW Record

[Table A-10](#) shows the sample SGSN data mapping for the S-GW record.

Table A-10 Sample SGSN Data Mapping for the S-GW Record

ASN1 Fields	SGSN	USED_UNITS[0].OUTPUT_VOLUME	Usage Object Parameter
listOfTrafficVolumes.dataVolumeGPRSUplink	part of 20209	USED_UNITS[0].OUTPUT_VOLUME	N/A
listOfTrafficVolumes.dataVolumeGPRSDownlink	part of 20209	USED_UNITS[0].INPUT_VOLUME	N/A
servedIMSI	20234 (ServedIMSI)	N/A	UserIdentity
chargingID	20001(ChargingID)	N/A	Session id
startTime	20274(StartTime)	N/A	Start time
stopTime	20275(StopTime) if it exists, otherwise derived from duration(20004)	N/A	End time
recordSequenceNumber	20005 (record sequence number)	N/A	sequence number

P-GW Record

[Table A-11](#) shows the sample SGSN data mapping for the P-GW record.

Table A-11 Sample SGSN Data Mapping for P-GW Record

ASN1 Fields	SGSN cartridge NPL Fields	ECE Payload Fields	ECE Usage Object Builder Parameter
listOfServiceData.datavolumeFBCUplink	part of 20267	USED_UNITS[0].OUTPUT_VOLUME	N/A
listOfService.datavolumeFBCDownlink	part of 20267	USED_UNITS[0].INPUT_VOLUME	N/A
servedIMSI	20234 (ServedIMSI)	N/A	UserIdentity
chargingID	20001(ChargingID)	N/A	Session id
startTime	20274	N/A	Start time
stopTime	20275(StopTime) if it exists, otherwise derived from duration(20004)	N/A	End time
recordSequenceNumber	20005 (record sequence number)	N/A	sequence number

SMS

The SGSNMMRecord (mobility management), SGSNMORRecord (Mobile originated) and SGSNMTRRecord (Mobile Terminated) record types are supported for Mobility management and SMS services.

20234 (ServedIMSI)

20219

Product Type = SMS

Event Type = USAGE

Usage Type = Terminate

[Table A-12](#) shows the sample SGSN SMS mapping for the Terminate usage type.

Table A-12 Sample SGSN SMS Mapping for the Terminate Usage Type

ASN1 Fields	SGSN cartridge NPL Fields	ECE Payload Fields	ECE Usage Object Builder Parameter
cellIdentifier	20223(CellIdentifier)	CELL_ID	N/A
destinationNumber	if SGSNMORRecord 20303(DestinationNumber), if SGSNMTRRecord same as 20234(servedIMSI)	CALLED_ID	N/A
N/A	N/A	USED_UNITS[0].SPECIFIC_UNIT	N/A
servedMSISDN or servedIMSI	N/A	N/A	UserIdentity
chargingID	20001(ChargingID)	N/A	Session id
eventTimeStamp	20240(EventTimeStamp)	N/A	Start time
eventTimeStamp	20240(EventTimeStamp)	N/A	end time

Table A-12 (Cont.) Sample SGSN SMS Mapping for the Terminate Usage Type

ASN1 Fields	SGSN cartridge NPL Fields	ECE Payload Fields	ECE Usage Object Builder Parameter
localSequenceNumber	N/A	N/A	seq number

Product Type = SMS

Event Type = USAGE

Usage Type = Update

[Table A-13](#) shows the sample SGSN SMS mapping for the Update usage type.

Table A-13 Sample SGSN SMS Mapping for the Update Usage Type

ASN1 Fields	SGSN cartridge NPL Fields	ECE Payload Fields	ECE Usage Object Builder Parameter
cellIdentifier	20223(CellIdentifier)	CELL_ID	N/A
destinationNumber	if SGSNMORRecord 20303(DestinationNumber), if SGSNMTRRecord same as 20234(servedIMSI)	CALLED_ID	N/A
N/A	N/A	USED_UNITS[0].SPECIFIC_ UNIT	N/A
servedMSISDN or servedIMSI	N/A	N/A	UserIdentity
chargingID	20001(ChargingID)	N/A	Session id
eventTimeStamp	20240(EventTimeStamp)	N/A	Start time
eventTimeStamp	20240(EventTimeStamp)	N/A	end time
localSequenceNumber	N/A	N/A	seq number

Product Type = SMS

Event Type = USAGE

Usage Type = Refund_Unit

[Table A-14](#) shows the sample SGSN SMS mapping for the Refund_Unit usage type.

Table A-14 Sample SGSN SMS Mapping for the Refund_Unit Usage Type

ASN1 Fields	SGSN cartridge NPL Fields	ECE Payload Fields	ECE Usage Object Builder Parameter
cellIdentifier	20223(CellIdentifier)	CELL_ID	N/A
destinationNumber	if SGSNMORRecord 20303(DestinationNumber), if SGSNMTRRecord same as 20234(servedIMSI)	CALLED_ID	N/A
N/A	N/A	USED_UNITS[0].SPECIFIC_ UNIT	N/A

Table A-14 (Cont.) Sample SGSN SMS Mapping for the Refund_Unit Usage Type

ASN1 Fields	SGSN cartridge NPL Fields	ECE Payload Fields	ECE Usage Object Builder Parameter
servedMSISDN or servedIMSI	N/A	N/A	UserIdentity
chargingID	20001(ChargingID)	N/A	Session id
eventTimeStamp	20240(EventTimeStamp)	N/A	Start time
eventTimeStamp	20240(EventTimeStamp)	N/A	end time
localSequenceNumber	N/A	N/A	seq number
correlation_identifier	N/A	CORRELATION_IDENTIFIE R	N/A

Product Type = SMS

Event Type= USAGE

Usage Type = Refund_Amount

[Table A-15](#) shows the sample SGSN SMS mapping for the Refund_Amount usage type.

Table A-15 Sample SGSN SMS Mapping for the Refund_Amount Usage Type

ASN1 Fields	SGSN cartridge NPL Fields	ECE Payload Fields	ECE Usage Object Builder Parameter
cellIdentifier	20223(CellIdentifier)	CELL_ID	N/A
destinationNumber	if SGSNMORRecord 20303(DestinationNumber), if SGSNMTRRecord same as 20234(servedIMSI)	CALLED_ID	N/A
N/A	N/A	USED_UNITS[0].SPECIFIC_ UNIT	N/A
servedMSISDN or servedIMSI	N/A	N/A	UserIdentity
chargingID	20001(ChargingID)	N/A	Session id
eventTimeStamp	20240(EventTimeStamp)	N/A	Start time
eventTimeStamp	20240(EventTimeStamp)	N/A	end time
localSequenceNumber	N/A	N/A	seq number
balance_element_id	N/A	IMPACT_AMOUNT[0].BALA NCE_ELEMENT_ID	N/A
amount	N/A	IMPACT_AMOUNT[0].AMOU NT	N/A
correlation_identifier	N/A	CORRELATION_IDENTIFIE R	N/A

Mapping for IMS

The ECE DC supports the following IMS product types:

- Voice

In case of IMS cartridge pack, the input is a Diameter ACR request, which the cartridge pack node chains convert into the 3GPP ASN1 format. The converted ASN1 format is the input to the ECE DC.

Voice

[Table A-16](#) shows the sample IMS voice mapping.

Table A-16 Sample IMS Voice Mapping

ASN1 Fields	IMS cartridge NPL Fields	ECE Payload Fields
Called_Party_Address	Called_Party_Address	CALLED_ID
derived using service delivery start time stamp and end time stamp	Duration	REQUESTED_UNITS[0].DURATION
PrivateUserID	PrivateUserID	UserIdentity
ServiceDeliveryStartTimeStamp	ServiceDeliveryStartTimeStamp	start time
ServiceDeliveryEndTimeStamp	ServiceDeliveryEndTimeStamp	end time
Session_Id	Session_Id	session id
N/A	seqNo	seq number

Mapping for Oracle CDR Format

The ECE DC supports the following Oracle CDR format product types:

- Voice
- Data
- SMS
- TelcoGsmTelephony
- TelcoGprs

Voice

Product Type = VOICE

Event Type = USAGE

Usage Type = Terminate

[Table A-17](#) shows the sample Oracle CDR format voice mappings for the Terminate usage type.

Table A-17 Sample Oracle CDR Format Voice Mapping for the Terminate Usage Type

Oracle CDR Format NPL Fields	ECE Payload Fields	ECE Usage Object Builder Parameter
A_NUMBER	N/A	UserIdentity

Table A-17 (Cont.) Sample Oracle CDR Format Voice Mapping for the Terminate Usage Type

Oracle CDR Format NPL Fields	ECE Payload Fields	ECE Usage Object Builder Parameter
N/A	N/A	Seq number
N/A	N/A	Session Id
CHARGING_START_TIMES TAMP	N/A	Start time
CHARGING_END_TIMESTA MP	N/A	End time
BASIC_SERVICE	N/A	cdr_service
DURATION	USED_UNITS[0].DURATION	N/A
B_NUMBER	CALLED_ID	N/A
CELL_ID	CELL_ID	N/A
USAGE_DIRECTION	USAGE_DIRECTION	N/A
CALL_COMPLETION_INDIC ATOR	TERMINATION_CAUSE	N/A
QOS_USED	QUALITY_OF_SERVICE	N/A

Data

Product Type = DATA

Event Type = DATA_USAGE

Usage Type = Terminate

[Table A-18](#) shows the sample Oracle CDR format data mappings for the Terminate usage type.

Table A-18 Sample Oracle CDR Format Data Mapping for the Terminate Usage Type

Oracle CDR Format NPL Fields	ECE Payload Fields	ECE Usage Object Builder Parameter
A_NUMBER	N/A	UserIdentity
N/A	N/A	Seq number
N/A	N/A	Session Id
CHARGING_START_TIMESTAMP	N/A	Start time
CHARGING_END_TIMESTAMP	N/A	End time
BASIC_SERVICE	N/A	cdr_service
VOLUME_SENT	USED_UNITS[0].INPUT_VOLUME	N/A
VOLUME_SENT + VOLUME_RECEIVED	USED_UNITS[0].TOTAL_VOLUME	N/A
N/A	USED_UNITS[0].CC_TIME	N/A
CHARGING_START_TIMESTAMP	USED_UNITS[0].VALIDITY_START	N/A
CHARGING_END_TIMESTAMP	USED_UNITS[0].VALIDITY_END	N/A
B_NUMBER	CALLED_ID	N/A
CELL_ID	CELL_ID	N/A

Table A-18 (Cont.) Sample Oracle CDR Format Data Mapping for the Terminate Usage Type

Oracle CDR Format NPL Fields	ECE Payload Fields	ECE Usage Object Builder Parameter
CALL_COMPLETION_INDICATOR	TERMINATION_CAUSE	N/A

SMS

Product Type = SMS

Event Type = SMS_USAGE

Usage Type = Terminate

[Table A-19](#) shows the sample Oracle CDR format SMS mapping for the Terminate usage type.

Table A-19 Sample Oracle CDR Format SMS Mapping for the Terminate Usage Type

Oracle CDR Format NPL Fields	ECE Payload Fields	ECE Usage Object Builder Parameter
A_NUMBER	N/A	UserIdentity
N/A	N/A	Seq number
N/A	N/A	Session Id
CHARGING_START_TIMESTAMP	N/A	Start time
CHARGING_END_TIMESTAMP	N/A	End time
BASIC_SERVICE	N/A	cdr_service
DURATION	USED_UNITS[0].SPECIFIC_UNIT	N/A
CALL_COMPLETION_INDICATOR	TERMINATION_CAUSE	N/A
B_NUMBER	CALLED_ID	N/A
CELL_ID	CELL_ID	N/A

TelcoGsmTelephony

Product Type = TelcoGsmTelephony

Event Type = ConvergentVoice

Usage Type = Terminate

[Table A-20](#) shows the sample Oracle CDR format TelcoGsmTelephony mapping for the Terminate usage type.

Table A-20 Sample Oracle CDR Format TelcoGsmTelephony Mapping for the Terminate Usage Type

Oracle CDR Format NPL Fields	ECE Payload Fields	ECE Usage Object Builder Parameter
A_NUMBER	N/A	UserIdentity
N/A	N/A	Seq number
N/A	N/A	Session Id

Table A-20 (Cont.) Sample Oracle CDR Format TelcoGsmTelephony Mapping for the Terminate Usage Type

Oracle CDR Format NPL Fields	ECE Payload Fields	ECE Usage Object Builder Parameter
CHARGING_START_TIMESTAMP	N/A	Start time
CHARGING_END_TIMESTAMP	N/A	End time
BASIC_SERVICE	N/A	cdr_service
CALL_COMPLETION_INDICATOR	TERMINATION_CAUSE	N/A
N/A	ZONE_ORIGIN	N/A
N/A	ZONE_DEST	N/A
USAGE_TYPE	USAGE_TYPE	N/A
B_NUMBER	CALLED_ID	N/A
N/A	TELCO_INFO[0].NETWORK_SESSION_ID	N/A
N/A	TELCO_INFO[0].NETWORK_SESSION_CORRELATION_ID	N/A
DESTINATION_NETWORK	TELCO_INFO[0].DESTINATION_NETWORK	N/A
MSID	TELCO_INFO[0].PRIMARY_MSID	N/A
N/A	TELCO_INFO[0].SECONDARY_MSID	N/A
A_NUMBER	TELCO_INFO[0].CALLING_FROM	N/A
B_NUMBER	TELCO_INFO[0].CALLED_TO	N/A
N/A	TELCO_INFO[0].SVC_TYPE	N/A
N/A	TELCO_INFO[0].SVC_CODE	N/A
USAGE_CLASS	TELCO_INFO[0].USAGE_CLASS	N/A
VOLUME_RECEIVED	TELCO_INFO[0].BYTES_DOWNLINK	N/A
VOLUME_SENT	TELCO_INFO[0].BYTES_UPLINK	N/A
ACTION_CODE	SERVICE_CODES[0].SS_ACTION_CODE	N/A
SS_CODE	SERVICE_CODES[0].SS_CODE	N/A
ESN_IMEI	GSM_INFO[0].IMEI	N/A
B_MODIFICATION_INDICATOR	GSM_INFO[0].CALLED_NUM_MODIF_MARK	N/A
USAGE_DIRECTION or CALL_DIRECTION	GSM_INFO[0].DIRECTION	N/A
B_NUMBER	GSM_INFO[0].DIALED_NUMBER	N/A
QOS_REQUESTED	GSM_INFO[0].QOS_REQUESTED	N/A
QOS_USED	GSM_INFO[0].QOS_NEGOTIATED	N/A
LONG_DURATION_INDICATOR	GSM_INFO[0].SUB_TRANS_ID	N/A
HOME_CARRIER_SID	GSM_INFO[0].ORIGIN_SID	N/A
HOME_CARRIER_SID	GSM_INFO[0].DESTINATION_SID	N/A
LOCATION_AREA_INDICATOR	GSM_INFO[0].LOC_AREA_CODE	N/A

Table A-20 (Cont.) Sample Oracle CDR Format TelcoGsmTelephony Mapping for the Terminate Usage Type

Oracle CDR Format NPL Fields	ECE Payload Fields	ECE Usage Object Builder Parameter
CELL_ID	GSM_INFO[0].CELL_ID	N/A
VOLUME_RECEIVED	GSM_INFO[0].BYTES_IN	N/A
VOLUME_SENT	GSM_INFO[0].BYTES_OUT	N/A
USAGE_CLASS	GSM_INFO[0].USAGE_CLASS	N/A
NUMBER_OF_UNITS	GSM_INFO[0].NUMBER_OF_UNIT	N/A
DURATION	USED_UNITS[0].DURATION	N/A
N/A	USED_UNITS[0].SPECIFIC_UNIT	N/A

TelcoGprs

Product Type = TelcoGprs

Event Type = ConvergentData

Usage Type = Terminate

[Table A-21](#) shows the sample Oracle CDR format TelcoGprs mapping for the Terminate usage type.

Table A-21 Sample Oracle CDR Format TelcoGprs Mapping for the Terminate Usage Type

Oracle CDR Format NPL Fields	ECE Payload Fields	ECE Usage Object Builder Parameter
A_NUMBER	N/A	UserIdentity
N/A	N/A	Seq number
N/A	N/A	Session Id
CHARGING_START_TIMESTAMP	N/A	Start time
CHARGING_END_TIMESTAMP	N/A	End time
BASIC_SERVICE	N/A	cdr_service
CALL_COMPLETION_INDICATOR	TERMINATION_CAUSE	N/A
USAGE_TYPE	USAGE_TYPE	N/A
B_NUMBER	CALLED_ID	N/A
N/A	TELCO_INFO[0].NETWORK_SESSION_ID	N/A
N/A	TELCO_INFO[0].NETWORK_SESSION_CORRELATION_ID	N/A
DESTINATION_NETWORK	TELCO_INFO[0].DESTINATION_NETWORK	N/A
MSID	TELCO_INFO[0].PRIMARY_MSID	N/A
PORT_NUMBER	TELCO_INFO[0].SECONDARY_MSID	N/A
A_NUMBER	TELCO_INFO[0].CALLING_FROM	N/A

Table A-21 (Cont.) Sample Oracle CDR Format TelcoGprs Mapping for the Terminate Usage Type

Oracle CDR Format NPL Fields	ECE Payload Fields	ECE Usage Object Builder Parameter
B_NUMBER	TELCO_INFO[0].CALLED_TO	N/A
N/A	TELCO_INFO[0].SVC_TYPE	N/A
N/A	TELCO_INFO[0].SVC_CODE	N/A
USAGE_CLASS	TELCO_INFO[0].USAGE_CLASS	N/A
VOLUME_RECEIVED	TELCO_INFO[0].BYTES_DOWNLINK	N/A
VOLUME_SENT	TELCO_INFO[0].BYTES_UPLINK	N/A
ROUTING_AREA	GPRS_INFO[0].ROUTING_AREA	N/A
LOCATION_AREA_INDICATOR	GPRS_INFO[0].LOC_AREA_CODE	N/A
CELL_ID	GPRS_INFO[0].CELL_ID	N/A
SESSION_ID	GPRS_INFO[0].SESSION_ID	N/A
SGSN_ADDRESS	GPRS_INFO[0].SGSN_ADDRESS	N/A
NODE_ID	GPRS_INFO[0].NODE_ID	N/A
TRANS_ID	GPRS_INFO[0].TRANS_ID	N/A
N/A	GPRS_INFO[0].EXTENSIONS	N/A
N/A	GPRS_INFO[0].STATUS	N/A
NETWORK_INITIATED_PDP	GPRS_INFO[0].NI_PDP	N/A
CONNECT_TYPE	GPRS_INFO[0].ANONYMOUS_LOGIN	N/A
PDP_TYPE	GPRS_INFO[0].PDP_TYPE	N/A
PDP_ADDRESS	GPRS_INFO[0].PDP_ADDRESS	N/A
PDP_REMOTE_ADDRESS	GPRS_INFO[0].PDP_RADDRESS	N/A
PDP_DYNAMIC_ADDRESS	GPRS_INFO[0].PDP_DYNADDR	N/A
DIAGNOSTICS	GPRS_INFO[0].DIAGNOSTICS	N/A
APN_ADDRESS	GPRS_INFO[0].APN	N/A
NUMBER_OF_UNITS	GPRS_INFO[0].NUMBER_OF_UNITS	N/A
NETWORK_CAPABILITY	GPRS_INFO[0].NETWORK_CAPABILITY	N/A
SGSN_CHANGE	GPRS_INFO[0].SGSN_CHANGE	N/A
CHANGE_CONDITION	GPRS_INFO[0].CHANGE_CONDITION	N/A
QOS_REQUESTED_PRECEDENCE	GPRS_INFO[0].QOS_REQ_PRECEDENCE	N/A
QOS_REQUESTED_DELAY	GPRS_INFO[0].QOS_REQ_DELAY	N/A
QOS_REQUESTED_RELIABILITY	GPRS_INFO[0].QOS_REQ_RELIABILITY	N/A
QOS_REQUESTED_PEAK_THROUGHPUT	GPRS_INFO[0].QOS_REQ_PEAK_THROUGHPUT	N/A
QOS_REQUESTED_MEAN_THROUGHPUT	GPRS_INFO[0].QOS_REQ_MEAN_THROUGHPUT	N/A
QOS_USED_PRECEDENCE	GPRS_INFO[0].QOS_NEGO_PRECEDENCE	N/A
QOS_USED_DELAY	GPRS_INFO[0].QOS_NEGO_DELAY	N/A

Table A-21 (Cont.) Sample Oracle CDR Format TelcoGprs Mapping for the Terminate Usage Type

Oracle CDR Format NPL Fields	ECE Payload Fields	ECE Usage Object Builder Parameter
QOS_USED_RELIABILITY	GPRS_INFO[0].QOS_NEGO_RELIABILITY	N/A
QOS_USED_PEAK_THROUGHPUT	GPRS_INFO[0].QOS_NEGO_PEAK_THROUGHPUT	N/A
QOS_USED_MEAN_THROUGHPUT	GPRS_INFO[0].QOS_NEGO_MEAN_THROUGHPUT	N/A
N/A	GPRS_INFO[0].SGSN_PLMN_ID	N/A
N/A	GPRS_INFO[0].MM_STATE	N/A
N/A	GPRS_INFO[0].PTMSI	N/A
N/A	GPRS_INFO[0].PTMSI_SIGNATURE	N/A
N/A	GPRS_INFO[0].SERVICE_AREA_CODE	N/A
N/A	GPRS_INFO[0].EXT_CHARGING_ID	N/A
N/A	GPRS_INFO[0].PS_CHARGING_DESCR	N/A
VOLUME_SENT	USED_UNITS[0].INPUT_VOLUME	N/A
VOLUME_RECEIVED	USED_UNITS[0].OUTPUT_VOLUME	N/A
VOLUME_SENT + VOLUME_RECEIVED	USED_UNITS[0].TOTAL_VOLUME	N/A

B

SGSN06 Cartridge Pack Version Hiding Reference

This appendix describes version hiding for the Offline Mediation Controller SGSN06 cartridge pack.

Version Hiding

Version hiding is supported for:

- V16.4.1 to V10.5.0
- V10.5.0 to V7.3.0
- V10.5.0 to V6.4.1
- V7.3.0 to V6.4.1
- V7.3.0 to V3.6.0
- V6.4.1 to V3.6.0
- V6.4.1 to V3.2.0
- V3.6.0 to V3.2.0

S-GW Record

[Table B-1](#) lists the S-GW record versions and their compatibility.

Table B-1 S-GW Record Versions and Compatibility

Version	Changes
v16.4.1	Supported.
v10.5.0	Supported.
v7.3.0	Not supported. Record will be ignored and message logged in log.
v6.4.1	Not supported. Record will be ignored and message logged in log.

P-GW Record

[Table B-2](#) lists the P-GW record versions and their compatibility.

Table B-2 P-GW Record Version and Compatibility

Version	Changes
v16.4.1	Supported.
v10.5.0	Supported.

Table B-2 (Cont.) P-GW Record Version and Compatibility

Version	Changes
v7.3.0	Not supported. Record will be ignored and message logged in log.
v6.4.1	Not supported. Record will be ignored and message logged in log.

AFChargingIdentifier Field

[Table B-3](#) lists the definitions for the AFCharginIdentifier field versions.

Table B-3 AFChargingIdentifier Field Versions

Version	Definition
v16.4.1	OCTECT STRING
v10.5	OCTECT STRING
v7.3.0	OCTECT STRING
v6.4.1	Not Present

[Table B-4](#) lists the versions that support version hiding.

Table B-4 AFChargingIdentifier Version Hiding

Version hiding	Changed fields	Changes
16.4.1 to 10.5	No change.	No change.
10.5 to 7.3.0	The field is not present in 7.3.0 definition supported Out of Box.	The field will be omitted from the output record.
10.5 to 6.4.1	The field is not present in the specification.	The field will be omitted from the output record.

AFRecordInformation Field

[Table B-5](#) lists the definitions for the AFRecordInformation field versions.

Table B-5 AFRecordInformation Field Versions

Version	Definition
v16.4.1	<pre> SEQUENCE aFChargingIdentifier [1] AFChargingIdentifier, flows [2] Flows OPTIONAL } </pre>

Table B-5 (Cont.) AFRecordInformation Field Versions

Version	Definition
v10.5	<pre>SEQUENCE aFChargingIdentifier [1] AFChargingIdentifier, flows [2] Flows OPTIONAL }</pre>

[Table B-6](#) lists the versions that support version hiding.

Table B-6 AFRecordInformation Version Hiding

Version hiding	Changed fields	Changes
16.4.1 to 10.5.0	No change.	No change.
10.5 to 7.3.0	The field is not present in 7.3.0 definition supported Out of Box.	The field will be omitted from the output record.
10.5 to 6.4.1	The field is not present in the specification.	The field will be omitted from the output record.

MSNetworkCapability Field

[Table B-7](#) lists the definitions for MSNetworkCapability field versions.

Table B-7 MSNetworkCapability Field Versions

Version	Definition
V7.3.0	MSNetworkCapability ::= OCTET STRING (SIZE(1..8))-- See 3G TS 24.008
V6.4.1	MSNetworkCapability ::= OCTET STRING (SIZE(1..8))-- See 3G TS 24.008
V3.6.0	MSNetworkCapability ::= OCTET STRING (SIZE(1))
V3.2.0	MSNetworkCapability ::= OCTET STRING (SIZE(1))

[Table B-8](#) lists the versions that support version hiding.

Table B-8 MSNetworkCapability Field Version Hiding

Version hiding	Changed fields	Changes
7.3.0 to 6.4.1	None.	No changes.
7.3.0 to 3.6.0	The size of field is 8 octets in 7.3.0.	Only Octet 1 will be kept.

Table B-8 (Cont.) MSNetworkCapability Field Version Hiding

Version hiding	Changed fields	Changes
6.4.1 to 3.6.0	The size of field is 8 octets in 6.4.1.	Only Octet 1 will be kept.
6.4.1 to 3.2.0	The size of field is 8 octets in 6.4.1.	Only Octet 1 will be kept.

CauseForRecClosing Field

[Table B-9](#) lists the definitions for CauseForRecClosing field versions.

Table B-9 CauseForRecClosing Field Versions

Version	Definition
v16.4.1	<pre> CauseForRecClosing ::= INTEGER normalRelease (0), abnormalRelease (4), cAMELInitCallRelease (5), volumeLimit (16), timeLimit (17), servingNodeChange (18), maxChangeCond (19), managementIntervention (20), intraSGSNIntersystemChange (21), rATChange (22), mSTimeZoneChange (23), sGSNPLMNIDChange (24), unauthorizedRequestingNetwork (52), unauthorizedLCSCClient (53), positionMethodFailure (54), unknownOrUnreachableLCSCClient (58), listOfDownstreamNodeChange (59) } </pre>

Table B-9 (Cont.) CauseForRecClosing Field Versions

Version	Definition
v10.5	<pre> CauseForRecClosing ::= INTEGER normalRelease (0), abnormalRelease (4), cAMELInitCallRelease (5), volumeLimit (16), timeLimit (17), servingNodeChange (18), maxChangeCond (19), managementIntervention (20), intraSGSNIntersystemChange (21), rATChange (22), mSTimeZoneChange (23), sGSNPLMNIDChange (24), unauthorizedRequestingNetwork (52), unauthorizedLCSCClient (53), positionMethodFailure (54), unknownOrUnreachableLCSCClient (58), listOfDownstreamNodeChange (59) } </pre>

Table B-9 (Cont.) CauseForRecClosing Field Versions

Version	Definition
v7.3.0	<pre> CauseForRecClosing ::= INTEGER { normalRelease (0), abnormalRelease (4), cAMELInitCallRelease (5), volumeLimit (16), timeLimit (17), sGSNChange (18), maxChangeCond (19), managementIntervention (20), intraSGSNIntersystemChange (21), rATChange (22), mSTimeZoneChange (23), unauthorizedRequestingNetwork (52), unauthorizedLCSCClient (53), positionMethodFailure (54), unknownOrUnreachableLCSCClient (58), listOfDownstreamNodeChange (59) } </pre>

Table B-9 (Cont.) CauseForRecClosing Field Versions

Version	Definition
v6.4.1	<pre> CauseForRecClosing ::= INTEGER { normalRelease (0), abnormalRelease (4), cAMELInitCallRelease (5), volumeLimit (16), timeLimit (17), sGSNChange (18), maxChangeCond (19), managementIntervention (20), intraSGSNIntersystemChange (21), rATChange (22), mSTimeZoneChange (23), unauthorizedRequestingNetwork (52), unauthorizedLCSCClient (53), positionMethodFailure (54), unknownOrUnreachableLCSCClient (58), listOfDownstreamNodeChange (59) } </pre>

Table B-9 (Cont.) CauseForRecClosing Field Versions

Version	Definition
v3.6.0	<pre>CauseForRecClosing ::= INTEGER { normalRelease (0), abnormalRelease (4), cAMELInitCallRelease (5), volumeLimit (16), timeLimit (17), sGSNChange (18), maxChangeCond (19), managementIntervention (20) }</pre>
v3.2.0	<pre>CauseForRecClosing ::= INTEGER { normalRelease (0), abnormalRelease (4), cAMELInitCallReleas (5), volumeLimit (16), timeLimit (17), sGSNChange (18), maxChangeCond (19), managementIntervention (20) }</pre>

[Table B-10](#) lists the versions that support version hiding.

Table B-10 CauseForRecClosing Field Version Hiding

Version hiding	Changed fields	Changes
16.4.1 to 10.5	New Values added in 16.4.1.1.	Do nothing. The new value defined in v16.4.1 will be output in v10.5.0.
10.5 to 7.3.0	New Values added in 10.5.	Do nothing. The new value defined in V10.5 will be output in V7.3.0.
10.5 to 6.4.1	New Values added in 10.5.	Do nothing. The new value defined in V10.5 will be output in V6.4.1.

Table B-10 (Cont.) CauseForRecClosing Field Version Hiding

Version hiding	Changed fields	Changes
7.3.0 to 6.4.1	None.	No changes.
7.3.0 to 3.6.0	None.	Do nothing. The new value defined in V7.3.0 will be output in V3.6.0.
6.4.1 to 3.6.0	Do nothing. The new value defined in V6.4.1 will be output in V3.6.0.	N/A
6.4.1 to 3.2.0	Do nothing. The new value defined in V6.4.1 will be output in V3.2.0.	N/A

ChangeCondition Field

[Table B-11](#) lists the definitions for ChangeCondition field versions.

Table B-11 ChangeCondition Field Versions

Version	Definition
v16.4.1	<pre> ChangeCondition ::= ENUMERATED { qoSChange (0), tariffTime (1), recordClosure (2), SAIChange CGI- (6), -- bearer modification. "CGI-SAI Change" rAIChange (7), -- bearer modification. "RAI Change" Establishment dT- (8), Removal dT- (9), eCGIChange (10), -- bearer modification. "ECGI Change" tAIChange (11), -- bearer modification. "TAI Change" userLocationChange (12), -- bearer modification. "User Location Change" userCSGInformationChange (13), -- bearer modification. "User CSG info Change modification. Change of UE Presence" removalOfAccess (15), -- NBIFOM "Removal of Access" unusabilityOfAccess (16), -- NBIFOM "Unusability of Access" indirectChangeCondition (17), -- NBIFOM "Indirect Change Condition" userPlaneToUEChange (18), -- bearer modification. "Change of user plane to UE" servingPLMNRateControlChange (19), -- bearer modification. "Serving PLMN Rate Control Change" threeGPPPSDataOffStatusChange (20), -- "Change of 3GPP PS DataOff Status" aPNRateControlChange (21), -- </pre>

Table B-11 (Cont.) ChangeCondition Field Versions

Version	Definition
	bearer modification. "APN Rate ControlChange }
v10.5	<pre> ChangeCondition ::= ENUMERATED { qoSChange (0), tariffTime (1), recordClosure (2), cGI- SAIChange (6), -- bearer modification. "CGI-SAI Change" rAIChange (7), -- bearer modification. "RAI Change" dT- Establishment (8), dT- Removal (9), eCGIChange (10), -- bearer modification. "ECGI Change" tAIChange (11), -- bearer modification. "TAI Change" userLocationChange (12), -- bearer modification. "User Location Change" } </pre>

Table B-11 (Cont.) ChangeCondition Field Versions

Version	Definition
V7.3.0	<pre> ChangeCondition ::= ENUMERATED { -- -- Failure Handling values used in eGCDR only -- qoSChange (0), tariffTime (1), recordClosure (2), failureHandlingContinueOngoing (3), failureHandlingRetryandTerminateOngoing (4), failureHandlingTerminateOngoing (5), cGI- SAIChange (6), rAIChange (7), dT- Establishment (8), dT- Removal (9) } </pre>
v6.4.1	<pre> ChangeCondition ::= ENUMERATED { -- -- Failure Handling values used in eGCDR only -- qoSChange (0), tariffTime (1), recordClosure (2), failureHandlingContinueOngoing (3), failureHandlingRetryandTerminateOngoing (4), failureHandlingTerminateOngoing (5) } </pre>

[Table B-12](#) lists the versions that support version hiding.

Table B-12 ChangeCondition Field Version Hiding

Version hiding	Changed fields	Changes
16.4.1 to 10.5	New values added in 16.4.1.	Do nothing. The new value defined in v16.4.1 will be output in v10.5.0.
10.5 to 7.3.0	New Values added in 10.5.	Do nothing. The new value defined in V10.5 will be output in v7.3.0.
10.5 to 6.4.1	New Values added in 10.5.	Do nothing. The new value defined in v10.5 will be output in v6.4.1.

ChangeOfCharCondition Field

[Table B-13](#) lists the definitions for ChangeOfCharCondition field versions.

Table B-13 ChangeOfCharCondition Field Versions

Version	Definition
v16.4.1	<pre> ChangeOfCharCondition ::= SEQUENCE { qosRequested [1] QoSInformation OPTIONAL, qosNegotiated [2] QoSInformation OPTIONAL, dataVolumeGPRSUplink [3] DataVolumeGPRS OPTIONAL, dataVolumeGPRSDownlink [4] DataVolumeGPRS OPTIONAL, changeCondition [5] ChangeCondition, changeTime [6] TimeStamp, userLocationInformation [8] OCTET STRING OPTIONAL, ePCQoSInformation [9] EPCQoSInformation OPTIONAL, chargingID [10] ChargingID OPTIONAL, presenceReportingAreaStatus [11] PresenceReportingAreaStatus OPTIONAL, userCSGInformation [12] UserCSGInformation OPTIONAL, diagnostics [13] Diagnostics OPTIONAL, enhancedDiagnostics [14] EnhancedDiagnostics OPTIONAL, rATType [15] RATType OPTIONAL, accessAvailabilityChangeReason [16] AccessAvailabilityChangeReason OPTIONAL, uWANUserLocationInformation [17] UWANUserLocationInfo OPTIONAL, relatedChangeOfCharCondition [18] RelatedChangeOfCharCondition OPTIONAL, cPCIoTEPSOptimisationIndicator [19] CPCIoTEPSOptimisationIndicator OPTIONAL, </pre>

Table B-13 (Cont.) ChangeOfCharCondition Field Versions

Version	Definition
	<pre> servingPLMNRateControl [20] ServingPLMNRateControl OPTIONAL, threeGPPPSDataOffStatus [21] ThreeGPPPSDataOffStatus OPTIONAL, listOfPresenceReportingAreaInformation [22] SEQUENCE OF PresenceReportingAreaInfo OPTIONAL, aPNRateControl [23] APNRateControl OPTIONAL } </pre>
v10.5	<pre> ChangeOfCharCondition ::= SEQUENCE { qosRequested [1] QoSInformation OPTIONAL, qosNegotiated [2] QoSInformation OPTIONAL, dataVolumeGPRSUplink [3] DataVolumeGPRS OPTIONAL, dataVolumeGPRSDownlink [4] DataVolumeGPRS OPTIONAL, changeCondition [5] ChangeCondition, changeTime [6] TimeStamp, userLocationInformation [8] OCTET STRING OPTIONAL, ePCQoSInformation [9] EPCQoSInformation OPTIONAL } </pre>

Table B-13 (Cont.) ChangeOfCharCondition Field Versions

Version	Definition
V7.3.0	<pre> ChangeOfCharCondition ::= SEQUENCE { qosRequested [1] QoSInformation OPTIONAL, qosNegotiated [2] QoSInformation OPTIONAL, dataVolumeGPRSUplink [3] DataVolumeGPRS OPTIONAL, dataVolumeGPRSDownlink [4] DataVolumeGPRS OPTIONAL, changeCondition [5] ChangeCondition, changeTime [6] TimeStamp, failureHandlingContinue [7] FailureHandlingContinue OPTIONAL, userLocationInformation [8] OCTET STRING OPTIONAL } </pre>
v6.4.1	<pre> ChangeOfCharCondition ::= SEQUENCE { qosRequested [1] QoSInformation OPTIONAL, qosNegotiated [2] QoSInformation OPTIONAL, dataVolumeGPRSUplink [3] DataVolumeGPRS, dataVolumeGPRSDownlink [4] DataVolumeGPRS, changeCondition [5] ChangeCondition, changeTime [6] TimeStamp } </pre>

[Table B-14](#) lists the versions that support version hiding.

Table B-14 ChangeOfCharCondition Field Version Hiding

Version hiding	Changed fields	Changes
16.4.1 to 10.5	New values added in 16.4.1.	Do nothing. The new value defined in v16.4.1 will be output in v10.5.0.
10.5 to 7.3.0	New Values added in 10.5.	Do nothing. The new value defined in v10.5 will be output in v7.3.0.
10.5 to 6.4.1	New Values added in 10.5.	Do nothing. The new value defined in v10.5 will be output in v6.4.1.

ChangeOfServiceCondition Field

[Table B-15](#) lists the definitions for ChangeOfServiceCondition field versions.

Table B-15 ChangeOfServiceCondition Field Versions

Version	Definition
v16.4.1	<pre> ChangeOfServiceCondition ::= SEQUENCE { ratingGroup [1] RatingGroupId, chargingRuleBaseName [2] ChargingRuleBaseName OPTIONAL, resultCode [3] ResultCode OPTIONAL, localSequenceNumber [4] LocalSequenceNumber OPTIONAL, timeOfFirstUsage [5] TimeStamp OPTIONAL, timeOfLastUsage [6] TimeStamp OPTIONAL, timeUsage [7] CallDuration OPTIONAL, serviceConditionChange [8] ServiceConditionChange, qoSInformationNeg [9] EPCQoSInformation OPTIONAL, servingNodeAddress [10] GSNAddress OPTIONAL, datavolumeFBCUplink [12] DataVolumeGPRS OPTIONAL, datavolumeFBCDownlink [13] DataVolumeGPRS OPTIONAL, timeOfReport [14] TimeStamp, failureHandlingContinue [16] FailureHandlingContinue OPTIONAL, serviceIdentifier [17] ServiceIdentifier OPTIONAL, pSFurnishChargingInformation [18] PSFurnishChargingInformation OPTIONAL, aFRecordInformation [19] SEQUENCE OF AFRecordInformation OPTIONAL, userLocationInformation [20] OCTET STRING OPTIONAL, </pre>

Table B-15 (Cont.) ChangeOfServiceCondition Field Versions

Version	Definition
	eventBasedChargingInformation [21] EventBasedChargingInformation OPTIONAL,
	timeQuotaMechanism [22] TimeQuotaMechanism OPTIONAL,
	serviceSpecificInfo [23] SEQUENCE OF ServiceSpecificInfo OPTIONAL,
	threeGPP2UserLocationInformation [24] OCTET STRING OPTIONAL,
	sponsorIdentity [25] OCTET STRING OPTIONAL,
	applicationServiceProviderIdentity [26] OCTET STRING OPTIONAL,
	aDCRuleBaseName [27] ADCRuleBaseName OPTIONAL,
	presenceReportingAreaStatus [28] PresenceReportingAreaStatus OPTIONAL,
	userCSGInformation [29] UserCSGInformation OPTIONAL,
	rATType [30] RATType OPTIONAL,
	uWANUserLocationInformation [32] UWANUserLocationInfo OPTIONAL,
	relatedChangeOfServiceCondition [33] RelatedChangeOfServiceCondition OPTIONAL,
	servingPLMNRateControl [35] ServingPLMNRateControl OPTIONAL,
	aPNRateControl [36] APNRateControl OPTIONAL,
	threeGPPPSDataOffStatus [37] ThreeGPPPSDataOffStatus OPTIONAL,
	trafficSteeringPolicyIDDnlink [38] TrafficSteeringPolicyIDDnlink OPTIONAL,
	trafficSteeringPolicyIDUplink [39] TrafficSteeringPolicyIDUplink OPTIONAL,
	tWANUserLocationInformation [40] TWANUserLocationInfo OPTIONAL,
	listOfPresenceReportingAreaInformation [41] SEQUENCE OF

Table B-15 (Cont.) ChangeOfServiceCondition Field Versions

Version	Definition
	<pre>PresenceReportingAreaInfo OPTIONAL, voLTEInformation [42] VoLTEInformation OPTIONAL }</pre>

Table B-15 (Cont.) ChangeOfServiceCondition Field Versions

Version	Definition
v10.5	<pre> ChangeOfServiceCondition ::= SEQUENCE { ratingGroup [1] RatingGroupId, chargingRuleBaseName [2] ChargingRuleBaseName OPTIONAL, resultCode [3] ResultCode OPTIONAL, localSequenceNumber [4] LocalSequenceNumber OPTIONAL, timeOfFirstUsage [5] TimeStamp OPTIONAL, timeOfLastUsage [6] TimeStamp OPTIONAL, timeUsage [7] CallDuration OPTIONAL, serviceConditionChange [8] ServiceConditionChange, qosInformationNeg [9] EPCQoSInformation OPTIONAL, servingNodeAddress [10] GSNAddress OPTIONAL, datavolumeFBCUplink [12] DataVolumeGPRS OPTIONAL, datavolumeFBCDownlink [13] DataVolumeGPRS OPTIONAL, timeOfReport [14] TimeStamp, failureHandlingContinue [16] FailureHandlingContinue OPTIONAL, serviceIdentifier [17] ServiceIdentifier OPTIONAL, pSFurnishChargingInformation [18] PSFurnishChargingInformation OPTIONAL, aFRecordInformation [19] SEQUENCE OF AFRecordInformation OPTIONAL, userLocationInformation [20] OCTET STRING OPTIONAL, </pre>

Table B-15 (Cont.) ChangeOfServiceCondition Field Versions

Version	Definition
	<pre> eventBasedChargingInformation [21] EventBasedChargingInformation OPTIONAL, timeQuotaMechanism [22] TimeQuotaMechanism OPTIONAL, serviceSpecificInfo [23] SEQUENCE OF ServiceSpecificInfo OPTIONAL, threeGPP2UserLocationInformation [24] OCTET STRING OPTIONAL } </pre>

Table B-15 (Cont.) ChangeOfServiceCondition Field Versions

Version	Definition
V7.3.0	<pre> ChangeOfServiceCondition ::= SEQUENCE { ratingGroup [1] RatingGroupId, chargingRuleBaseName [2] ChargingRuleBaseName OPTIONAL, resultCode [3] ResultCode OPTIONAL, localSequenceNumber [4] LocalSequenceNumber OPTIONAL, timeOfFirstUsage [5] TimeStamp OPTIONAL, timeOfLastUsage [6] TimeStamp OPTIONAL, timeUsage [7] CallDuration OPTIONAL, serviceConditionChange [8] ServiceConditionChange, qoSInformationNeg [9] QoSInformation OPTIONAL, sgsn- Address [10] GSNAddress OPTIONAL, sGSNPLMNIdentifier [11] SGSNPLMNIdentifier OPTIONAL, datavolumeFBCUplink [12] DataVolumeGPRS OPTIONAL, datavolumeFBCDownlink [13] DataVolumeGPRS OPTIONAL, timeOfReport [14] TimeStamp, rATType [15] RATType OPTIONAL, failureHandlingContinue [16] FailureHandlingContinue OPTIONAL, serviceIdentifier [17] ServiceIdentifier OPTIONAL, pSFurnishChargingInformation [18] PSFurnishChargingInformation OPTIONAL, </pre>

Table B-15 (Cont.) ChangeOfServiceCondition Field Versions

Version	Definition
	<pre> aFRecordInformation [19] SEQUENCE OF AFRecordInformation OPTIONAL, userLocationInformation [20] OCTET STRING OPTIONAL, eventBasedChargingInformation [21] EventBasedChargingInformation OPTIONAL, timeQuotaMechanism [22] TimeQuotaMechanism OPTIONAL } </pre>

Table B-15 (Cont.) ChangeOfServiceCondition Field Versions

Version	Definition
v6.4.1	<pre> ChangeOfServiceCondition ::= SEQUENCE { ratingGroup [1] RatingGroupId, chargingRuleBaseName [2] ChargingRuleBaseName OPTIONAL, resultCode [3] ResultCode OPTIONAL, localSequenceNumber [4] LocalSequenceNumber OPTIONAL, timeOfFirstUsage [5] TimeStamp OPTIONAL, timeOfLastUsage [6] TimeStamp OPTIONAL, timeUsage [7] CallDuration OPTIONAL, serviceConditionChange [8] ServiceConditionChange, qosInformationNeg [9] QoSInformation OPTIONAL, sgsn- Address [10] GSNAddress OPTIONAL, sGSNPLMNIdentifier [11] SGSNPLMNIdentifier OPTIONAL, datavolumeFBCUplink [12] DataVolumeGPRS OPTIONAL, datavolumeFBCDownlink [13] DataVolumeGPRS OPTIONAL, timeOfReport [14] TimeStamp, rATType [15] RATType OPTIONAL, failureHandlingContinue [16] FailureHandlingContinue OPTIONAL, serviceIdentifier [17] ServiceIdentifier OPTIONAL, pSFurnishChargingInformation [18] PSFurnishChargingInformation OPTIONAL } </pre>

[Table B-16](#) lists the versions that support version hiding.

Table B-16 ChangeOfServiceCondition Version Hiding

Version hiding	Changed fields	Changes
16.4.1 to 10.5	New values added in 16.4.1.	Do nothing. The new value defined in v16.4.1 will be output in v10.5.0.
10.5 to 7.3.0	New Values added in 10.5.	Do nothing. The new value defined in v10.5 will be output in v7.3.0.
10.5 to 6.4.1	New Values added in 10.5.	Do nothing. The new value defined in v10.5 will be output in v6.4.1.

CSGAccessMode Field

[Table B-17](#) lists the definitions for CSGAccessMode field versions.

Table B-17 CSGAccessMode Field Versions

Version	Definition
v16.4.1	<pre>CSGAccessMode ::= ENUMERATED { ClosedMode (0), HybridMode (1) }</pre>
v10.5	<pre>CSGAccessMode ::= ENUMERATED { ClosedMode (0), HybridMode (1) }</pre>
V7.3.0	Not Present Bit 0-3: Profile Index
v6.4.1	Not Present

[Table B-18](#) lists the versions that support version hiding.

Table B-18 CSGAccessMode Version Hiding

Version hiding	Changed fields	Changes
10.5 to 7.3.0	The field is not present in 7.3.0 definition.	The field will be omitted from the output record.
10.5 to 6.4.1	The field is not present in the 6.4.1 definition.	The field will be omitted from the output record.

CSGIId Field

[Table B-19](#) lists the definitions for CSGId field versions.

Table B-19 CSGId Field Versions

Version	Definition
v16.4.1	CSGId ::= OCTET STRING (SIZE(4))
v10.5	CSGId ::= OCTET STRING (SIZE(4))
v7.3.0	OCTET STRING
v6.4.1	Not Present

[Table B-20](#) lists the versions that support version hiding.

Table B-20 CSGId Field Version Hiding

Version hiding	Changed fields	Changes
16.4.1 to 10.5	No changes in field.	The field will be flown to the output record.
10.5 to 7.3.0	The field is not present in 7.3.0 definition.	The field will be omitted from the output record.
10.5 to 6.4.1	The field is not present in 6.4.1 definition.	The field will be omitted from the output record.

ChargingCharacteristics Field

[Table B-21](#) lists the definitions for ChargingCharacteristics field versions.

Table B-21 ChargingCharacteristics Field Versions

Version	Definition
V7.3.0	ChargingCharacteristics ::= OCTET STRING (SIZE(2)) Bit 4-15: For Behavior
V6.4.1	ChargingCharacteristics ::= OCTET STRING (SIZE(2)) Bit 0-3: Profile Index Bit 4-15: For Behavior
V3.6.0	ChargingCharacteristics ::= OCTET STRING (SIZE(2)) Descriptions for the bits of the flag set: Bit 1: H (Hot billing) := '00000001'B Bit 2: F (Flat rate) := '00000010'B Bit 3: P (Prepaid service) := '00000100'B Bit 4: N (Normal billing) := '00001000'B Bit 5: - (Reserved, set to 0) := '00010000'B Bit 6: - (Reserved, set to 0) := '00100000'B Bit 7: - (Reserved, set to 0) := '01000000'B Bit 8: - (Reserved, set to 0) := '10000000'B

Table B-21 (Cont.) ChargingCharacteristics Field Versions

Version	Definition
V3.2.0	<pre>ChargingCharacteristics ::= OCTET STRING (SIZE(1)) Descriptions for the bits of the flag set: Bit 1: H (Hot billing) := '00000001'B Bit 2: F (Flat rate) := '00000010'B Bit 3: P (Prepaid service) := '00000100'B Bit 4: N (Normal billing) := '00001000'B Bit 5: - (Reserved, set to 0) := '00010000'B Bit 6: - (Reserved, set to 0) := '00100000'B Bit 7: - (Reserved, set to 0) := '01000000'B Bit 8: - (Reserved, set to 0) := '10000000'B</pre>

[Table B-22](#) lists the versions that support version hiding.

Table B-22 ChargingCharacteristics Field Version Hiding

Version hiding	Changed fields	Changes
7.3.0 to 6.4.1	None.	No changes.
7.3.0 to 6.4.1	None.	No changes.
6.4.1 to 3.6.0	No change. The new values set for bits 4-15 for V6.4.1 will be output in V3.6.0. These will be ignored in V3.6.0.	
6.4.1 to 3.2.0	Only Octet 1 will be kept and output in V3.2.0.	

EventBasedChargingInformation Field

[Table B-23](#) lists the definitions for EventBasedChargingInformation field versions.

Table B-23 EventBasedChargingInformation Field Versions

Version	Definition
v16.4.1	<pre>EventBasedChargingInformation ::= SEQUENCE { numberOfEvents [1] INTEGER, eventTimeStamps [2] SEQUENCE OF TimeStamp OPTIONAL }</pre>
v10.5	<pre>EventBasedChargingInformation ::= SEQUENCE { numberOfEvents [1] INTEGER, eventTimeStamps [2] SEQUENCE OF TimeStamp OPTIONAL }</pre>

Table B-23 (Cont.) EventBasedChargingInformation Field Versions

Version	Definition
V7.3.0	<pre>EventBasedChargingInformation ::= SEQUENCE { numberOfEvents [1] INTEGER, eventTimeStamps [2] SEQUENCE OF TimeStamp OPTIONAL }</pre>
v6.4.1	<pre>Not Present --</pre>

[Table B-24](#) lists the versions that support version hiding.

Table B-24 EventBasedChargingInformation Field Version Hiding

Version hiding	Changed fields	Changes
16.4.1 to 10.5	No change.	Do nothing. The new value defined in v16.4.1 will be output in v10.5.0.
10.5 to 7.3.0	No change.	Do nothing. The new value defined in v10.5 will be output in v7.3.0.
10.5 to 6.4.1	The field is not present in the definition.	The field will be omitted from the output record.

EPCQoSInformation Field

[Table B-25](#) lists the definitions for EPCQoSInformation field versions.

Table B-25 EPCQoSInformation Field Versions

Version	Definition
v16.4.1	<pre> EPCQoSInformation ::= SEQUENCE -- See TS 29.212 [220] for more information -- { qCI [1] INTEGER, maxRequestedBandwidthUL [2] INTEGER OPTIONAL, maxRequestedBandwidthDL [3] INTEGER OPTIONAL, guaranteedBitrateUL [4] INTEGER OPTIONAL, guaranteedBitrateDL [5] INTEGER OPTIONAL, aRP [6] INTEGER OPTIONAL, aPNAggregateMaxBitrateUL [7] INTEGER OPTIONAL, aPNAggregateMaxBitrateDL [8] INTEGER OPTIONAL, extendedMaxRequestedBWUL [9] INTEGER OPTIONAL, extendedMaxRequestedBWDL [10] INTEGER OPTIONAL, extendedGBRUL [11] INTEGER OPTIONAL, extendedGBRDL [12] INTEGER OPTIONAL, extendedAPNAMBRUL [13] INTEGER OPTIONAL, extendedAPNAMBRDL [14] INTEGER OPTIONAL } </pre>

Table B-25 (Cont.) EPCQoSInformation Field Versions

Version	Definition
v10.5	<pre> EPCQoSInformation ::= SEQUENCE -- See TS 29.212 [220] for more information -- { qCI [1] INTEGER, maxRequestedBandwidthUL [2] INTEGER OPTIONAL, maxRequestedBandwidthDL [3] INTEGER OPTIONAL, guaranteedBitrateUL [4] INTEGER OPTIONAL, guaranteedBitrateDL [5] INTEGER OPTIONAL, aRP [6] INTEGER OPTIONAL, aPNAggregateMaxBitrateUL [7] INTEGER OPTIONAL, aPNAggregateMaxBitrateDL [8] INTEGER OPTIONAL } </pre>
V7.3.0	Not Present {
v6.4.1	Not Present

[Table B-26](#) lists the versions that support version hiding.

Table B-26 EPCQoSInformation Field Version Hiding

Version hiding	Changed fields	Changes
16.4.1 to 10.5	New fields are added.	The fields will directly flow to output.
10.5 to 7.3.0	The field is not present in 7.3.0 definition.	The field will be omitted from the output record.
10.5 to 6.4.1	The field is not present in 6.4.1 definition.	The field will be omitted from the output record.

QoSInformation Field

[Table B-27](#) lists the definitions for QoSInformation field versions.

Table B-27 QoSInformation Field Versions

Version	Definition
v16.4.1	<pre> QoSInformation ::= OCTET STRING (SIZE (4..255)) </pre>

Table B-27 (Cont.) QoSInformation Field Versions

Version	Definition
v10.5	QoSInformation ::= OCTET STRING (SIZE (4..255))
v7.3.0	QoSInformation ::= OCTET STRING (SIZE (4..15))
v6.4.1	QoSInformation ::= OCTET STRING (SIZE (4..15))

[Table B-28](#) lists the versions that support version hiding.

Table B-28 QoSInformation Field Version Hiding

Version hiding	Changed fields	Changes
10.5 to 7.3.0	The max size of field is 255 in 10.5 and 15 in 7.3.0.	Only upto 15 octets will be kept.
10.5 to 6.4.1	The max size of field is 255 in 10.5 and 15 in 6.4.1.	Only upto 15 octets will be kept.

ListOfTrafficVolumes Field

[Table B-29](#) lists the definitions for ListOfTrafficVolumes field versions.

Table B-29 ListOfTrafficVolumes Field Versions

Version	Definition
V7.3.0	<pre> ChangeOfCharCondition ::= SEQUENCE Used in PDP context record only qosRequested [1] QoSInformation OPTIONAL, qosNegotiated [2] QoSInformation OPTIONAL, dataVolumeGPRSUplink [3] DataVolumeGPRSOPTIONAL, dataVolumeGPRSDownlink [4] DataVolumeGPRS OPTIONAL, changeCondition [5] ChangeCondition, changeTime [6] TimeStamp, failureHandlingContinue [7] FailureHandlingContinue OPTIONAL, userLocationInformation [8] OCTET STRING OPTIONAL } ChangeCondition ::= ENUMERATED { Failure Handling values used in eGCDR only qoSChange (0), tariffTime (1), recordClosure (2), failureHandlingContinueOngoing (3), failureHandlingRetryandTerminateOngoing(4), failureHandlingTerminateOngoing (5), cGI-SAICChange (6), rAICChange (7), dT-Establishment (8), dT-Removal (9) } </pre>
V6.4.1	<pre> ChangeOfCharCondition ::= SEQUENCE { Used in PDP context record only qosRequested [1] QoSInformation OPTIONAL, qosNegotiated [2] QoSInformation OPTIONAL, dataVolumeGPRSUplink [3] DataVolumeGPRS, dataVolumeGPRSDownlink [4] DataVolumeGPRS, changeCondition [5] ChangeCondition, changeTime [6] TimeStamp } ChangeCondition ::= ENUMERATED { Failure Handling values used in eGCDR only qoSChange (0), tariffTime (1), recordClosure (2), failureHandlingContinueOngoing (3), failureHandlingRetryandTerminateOngoing (4), failureHandlingTerminateOngoing (5) } QoSInformation ::= OCTET STRING (SIZE (4..15)) </pre>

Table B-29 (Cont.) ListOfTrafficVolumes Field Versions

Version	Definition
V3.6.0	<pre> ChangeOfCharCondition ::= SEQUENCE Used in PDP context record only { qosRequested [1] QoSInformation OPTIONAL, qosNegotiated [2] QoSInformation OPTIONAL, dataVolumeGPRSUpLink [3] DataVolumeGPRS, dataVolumeGPRSDownlink [4] DataVolumeGPRS, changeCondition [5] ChangeCondition, changeTime [6] TimeStamp } ChangeCondition ::= ENUMERATED { qoSChange (0), tariffTime (1), recordClosure (2) } QoSInformation ::= CHOICE { gsmQoSInformation [0] GSMQoSInformation, umtsQoSInformation [1] OCTET STRING (SIZE (12)) } GSMQoSInformation ::=SEQUENCE { reliability [0] QoSReliability, delay [1] QoSDelay, precedence [2] QoSPrecedence, peakThroughput [3] QoSPeakThroughput, meanThroughput [4] QoSMeanThroughput } </pre>

Table B-29 (Cont.) ListOfTrafficVolumes Field Versions

Version	Definition
V3.2.0	<pre> ChangeOfCharCondition ::= SEQUENCE Used in PDP context record only { qosRequested [1] QoSInformation OPTIONAL, qosNegotiated [2] QoSInformation OPTIONAL, dataVolumeGPRSUpLink [3] DataVolumeGPRS, dataVolumeGPRSDownlink [4] DataVolumeGPRS, changeCondition [5] ChangeCondition, changeTime [6] TimeStamp } ChangeCondition ::= ENUMERATED { qosChange (0), tariffTime (1), recordClosure (2) } QoSInformation ::= CHOICE { gsmQoSInformation [0] GSMQoSInformation, umtsQoSInformation [1] UMTSQoSInformation } GSMQoSInformation ::=SEQUENCE { reliability [0] QoSReliability, delay [1] QoSDelay, precedence [2] QoSPrecedence, peakThroughput [3] QoSPeakThroughput, meanThroughput [4] QoSMeanThroughput } UMTSQoSInformation ::=SEQUENCE { trafficClass [0] QoSTrafficClass, maxBitRateUpLink [1] QoSMaxBitRate, maxBitRateDownlink [2] QoSMaxBitRate, deliveryOrder [3] QoSDeliveryOrder, maxSDUsize [4] QoSMaxSDUsize, sduErrorRatio [6] </pre>

Table B-29 (Cont.) ListOfTrafficVolumes Field Versions

Version	Definition
	<pre> QoSSErrorRatio, residualBER [7] QoSResidualBER, erroneousSDUs [8] QoSErroneousSDUs, transferDelay [9] QoSTransferDelay, handlingPriority [10] QoSHandlingPriority, allocRetenPriority [11] QoSAllocRetenPriority } </pre>

[Table B-30](#) lists the versions that support version hiding.

Table B-30 ListOfTrafficVolumes Field Version Hiding

Version hiding	Changed fields	Changes
7.3.0 to 6.4.1	<p>Two new values for ChangeCondition.</p> <p>DataVolumeGPRSUplink and dataVolumeGPRSDownlink are made optional.</p>	<p>For ChangeOfCharCondition:</p> <p>If the dataVolumeGPRSUplink or dataVolumeGPRSDownlink or both were empty, a value of '0' (zero) would be populated.</p> <p>If the dataVolumeGPRSUplink or dataVolumeGPRSDownlink have any value, they will be sent as is.</p> <p>For ChangeCondition:</p> <p>Do nothing. The new value defined in V7.3.0 will be output in V6.4.1.</p>
7.3.0 to 3.6.0	<p>For ChangeOfCharCondition:</p> <p>If the dataVolumeGPRSUplink or dataVolumeGPRSDownlink or both were empty, a value of '0' (zero) would be populated.</p> <p>If the dataVolumeGPRSUplink or dataVolumeGPRSDownlink have any value, they will be sent as is.</p> <p>For ChangeCondition:</p> <p>Do nothing. The new value defined in V7.3.0 will be output in V3.6.0.</p> <p>This is done over what has been already done from V6.4.1 to V3.6.0.</p>	N/A

Table B-30 (Cont.) ListOfTrafficVolumes Field Version Hiding

Version hiding	Changed fields	Changes
6.4.1 to 3.6.0	<p>For ChangeCondition - The new values are supposed for eGCDR only. Those new values should not be presented in SCDR, MCDR, SMT, and SMO CDR.</p> <p>For QoSInformation:</p> <p>If the field value length is 4, octet 1 is Allocation/Retention Priority, octets 2 - 4 are coded according to 3GPP TS 24.008 [5] Quality of Service IE, octets 3 - 5 (i.e. according to the pre-Release '99 format). This will be converted into choice, GSMQoSInformation.</p> <p>If the field value length is 12, it will be converted into choice, umtsQoSInformation. It will be 1:1 octet copy (input 12 octets, output is also 12 octets).</p> <p>If the field value length is more than 12 (less or equal to 15), it will be converted into choice, umtsQoSInformation. Output value for choice umtsQoSInformation will be the first 12 octets from the input.</p>	N/A

Table B-30 (Cont.) ListOfTrafficVolumes Field Version Hiding

Version hiding	Changed fields	Changes
6.4.1 to 3.2.0	<p>For ChangeCondition - The new values are supposed for eGCDR only. Those new values should not be presented in SCDR, MCDR, SMT, and SMO CDR.</p> <p>For QoSInformation:</p> <p>If the field value length is 4, octet 1 is Allocation/Retention Priority, octets 2 - 4 are coded according to 3GPP TS 24.008 [5] Quality of Service IE, octets 3 - 5 (i.e. according to the pre-Release '99 format). This will be converted into choice, GSMQoSInformation.</p> <p>If the field value length is 12, it will be converted into choice, umtsQoSInformation. It will be 1:1 octet copy (input 12 octets, output is also 12 octets).</p> <p>If the field value length is more than 12 (less or equal to 15), it will be converted into choice, umtsQoSInformation. Output value for choice umtsQoSInformation will be the first 12 octets from the input.</p>	N/A

RATType Field

[Table B-31](#) lists the definitions for RATType field versions.

Table B-31 RATType Field Versions

Version	Definition
V7.3.0	<pre>RATType ::= INTEGER (0..255) {</pre>
V6.4.1	<pre>RATType ::= INTEGER (0..255)</pre>
V3.6.0	<p>This field is not defined in V3.6.0. Instead, a similar field is defined as the following:</p> <pre>SystemType ::= ENUMERATED unknown (0), iuUTRAN (1) }</pre>

Table B-31 (Cont.) RATType Field Versions

Version	Definition
V3.2.0	This field is not defined in V3.2.0. Instead, a similar field is defined as the following: <pre>SystemType ::= ENUMERATED { umtsRel99 (1) }</pre>

[Table B-32](#) lists the versions that support version hiding.

Table B-32 RATType Field Version Hiding

Version hiding	Changed fields	Changes
7.3.0 to 6.4.1	None.	No changes.
7.3.0 to 3.6.0	None.	No changes.
6.4.1 to 3.6.0	If the input V6.4.1 value is not 1, it will be output as SystemType with the value 0. Otherwise, it will be output as SystemType with the value 1.	N/A
6.4.1 to 3.2.0	It will be dropped.	N/A

ChChSelectionMode Field

[Table B-33](#) lists the definitions for ChChSelectionMode field versions.

Table B-33 ChChSelectionMode Field Versions

Version	Definition
V7.3.0	<pre>ChChSelectionMode ::= ENUMERATED { sGSNSupplied (0), -- For GGSN only subscriptionSpecific (1), -- For SGSN only aPNSpecific (2), -- For SGSN only homeDefault (3), -- For SGSN and GGSN roamingDefault (4), -- For SGSN and GGSN visitingDefault (5) -- For SGSN and GGSN }</pre>

Table B-33 (Cont.) ChChSelectionMode Field Versions

Version	Definition
V6.4.1	<pre>ChChSelectionMode ::= ENUMERATED { sGSNSupplied (0), -- For GGSN only subscriptionSpecific (1), -- For SGSN only aPNSpecific (2), -- For SGSN only homeDefault (3), -- For SGSN and GGSN roamingDefault (4), -- For SGSN and GGSN visitingDefault (5) -- For SGSN and GGSN }</pre>
V3.6.0	No such field defined for SGSNPDPRecord, SGSNMMRecord, SGSNSMORRecord, and SGSNSMTRRecord.
V3.2.0	No such field defined for SGSNPDPRecord, SGSNMMRecord, SGSNSMORRecord, and SGSNSMTRRecord.

[Table B-34](#) lists the versions that support version hiding.

Table B-34 ChChSelectionMode Field Version Hiding

Version hiding	Changed fields	Changes
7.3.0 to 6.4.1	None.	No changes.
7.3.0 to 3.6.0	None.	No changes.
6.4.1 to 3.6.0	Field will be dropped for SGSNPDPRecord, SGSNMMRecord, SGSNSMORRecord, and SGSNSMTRRecord.	N/A
6.4.1 to 3.2.0	Field will be dropped for SGSNPDPRecord, SGSNMMRecord, SGSNSMORRecord, and SGSNSMTRRecord.	N/A

DynamicAddressFlag Field

[Table B-35](#) lists the definitions for DynamicAddressFlag field versions.

Table B-35 DynamicAddressFlag Field Versions

Version	Definition
V7.3.0	<pre>DynamicAddressFlag ::= BOOLEAN {</pre>
V6.4.1	<pre>DynamicAddressFlag ::= BOOLEAN</pre>
V3.6.0	No such field is defined for SGSNPDPRecord, SGSNSMORRecord, and SGSNSMTRRecord.

Table B-35 (Cont.) DynamicAddressFlag Field Versions

Version	Definition
V3.2.0	No such field is defined for SGSNPDPRecord, SGSNSMORRecord, and SGSNSMTRRecord.

[Table B-36](#) lists the versions that support version hiding.

Table B-36 DynamicAddressFlag Field Version Hiding

Version hiding	Changed fields	Changes
7.3.0 to 6.4.1	None.	No changes.
7.3.0 to 3.6.0	None.	No changes.
6.4.1 to 3.6.0	Field will be dropped for SGSNPDPRecord, SGSNMMRecord, SGSNSMORRecord, and SGSNSMTRRecord.	N/A
6.4.1 to 3.2.0	Field will be dropped for SGSNPDPRecord, SGSNMMRecord, SGSNSMORRecord, and SGSNSMTRRecord.	N/A

EventTimeStamp Field

[Table B-37](#) lists the definitions for EventTimeStamp field versions.

Table B-37 EventTimeStamp Field Versions

Version	Definition
V7.3.0	Defined in SGSNSMORRecord and SGSNSMTRRecord as TimeStamp, replacing originationTime in V3.6.0 and V3.2.0.
V6.4.1	Defined in SGSNSMORRecord and SGSNSMTRRecord as TimeStamp, replacing originationTime in V3.6.0 and V3.2.0.
V3.6.0	No such field; instead, it has originationTime.
V3.2.0	No such field; instead, it has originationTime.

[Table B-38](#) lists the versions that support version hiding.

Table B-38 EventTimeStamp Field Version Hiding

Version hiding	Changed fields	Changes
7.3.0 to 6.4.1	None.	No changes.
7.3.0 to 3.6.0	None.	No changes.
6.4.1 to 3.6.0	Output it as originationTime.	N/A
6.4.1 to 3.2.0	Output it as originationTime.	N/A

CAMELInformationSMS Field

[Table B-39](#) lists the definitions for CAMELInformationSMS field versions.

Table B-39 CAMELInformationSMS Field Versions

Version	Definition
V7.3.0	<pre> CAMELInformationSMS ::= SET sCFAddress [1] SCFAddress OPTIONAL, serviceKey [2] ServiceKey OPTIONAL, defaultSMShandling [3] DefaultSMS-Handling OPTIONAL, cAMELCallingPartyNumber [4] CallingNumber OPTIONAL, cAMELDestinationSubscriberNumber [5] SmsTpDestinationNumber OPTIONAL, cAMELSMSCAddress [6] AddressString OPTIONAL, freeFormatData [7] FreeFormatData OPTIONAL, smsReferenceNumber [8] CallReferenceNumber OPTIONAL } </pre>
V6.4.1	<pre> CAMELInformationSMS ::= SET { sCFAddress [1] SCFAddress OPTIONAL, serviceKey [2] ServiceKey OPTIONAL, defaultSMShandling [3] DefaultSMS-Handling OPTIONAL, cAMELCallingPartyNumber [4] CallingNumber OPTIONAL, cAMELDestinationSubscriberNumber [5] SmsTpDestinationNumber OPTIONAL, cAMELSMSCAddress [6] AddressString OPTIONAL, freeFormatData [7] FreeFormatData OPTIONAL, smsReferenceNumber [8] CallReferenceNumber OPTIONAL } </pre>

Table B-39 (Cont.) CAMELInformationSMS Field Versions

Version	Definition
V3.6.0	<pre> CAMELInformationSMS ::= SET { sCFAddress [1] SCFAddress OPTIONAL, serviceKey [2] ServiceKey OPTIONAL, defaultSMShandling [3] DefaultSMS-Handling OPTIONAL, cAMELCallingPartyNumber [4] CallingNumber OPTIONAL, cAMELDestinationSubscriberNumber [5] CalledNumber OPTIONAL, cAMELSMSCAddress [6] AddressString OPTIONAL, freeFormatData [7] FreeFormatData OPTIONAL } </pre>
V3.2.0	<pre> CAMELInformationSMS ::= SET { sCFAddress [1] SCFAddress OPTIONAL, serviceKey [2] ServiceKey OPTIONAL, defaultSMShandling [3] DefaultSMS-Handling OPTIONAL, cAMELCallingPartyNumber [4] CallingNumber OPTIONAL, cAMELDestinationSubscriberNumber [5] CalledNumber OPTIONAL, cAMELSMSCAddress [6] AddressString OPTIONAL, freeFormatData [7] FreeFormatData OPTIONAL } </pre>

[Table B-40](#) lists the versions that support version hiding.

Table B-40 CAMELInformationSMS Field Version Hiding

Version hiding	Changed fields	Changes
7.3.0 to 6.4.1	None.	No changes.
7.3.0 to 3.6.0	None.	No changes.
6.4.1 to 3.6.0	Drop smsReferenceNumber.	N/A
6.4.1 to 3.2.0	Drop smsReferenceNumber.	N/A

SMSResult/Diagnostics Field

[Table B-41](#) lists the definitions for SMSResult/Diagnostics field versions.

Table B-41 SMSResult/Diagnostics Field Versions

Version	Definition
V7.3.0	<pre> SMSResult ::= Diagnostics insufficientResources (1), Diagnostics ::= CHOICE { gsm0408Cause [0] INTEGER, -- See TS 24.008 gsm0902MapErrorValue [1] INTEGER, itu-tQ767Cause [2] INTEGER, -- See ITU-T Q.767 networkSpecificCause [3] ManagementExtension, -- To be defined by network operator manufacturerSpecificCause [4] ManagementExtension, -- To be defined by manufacturer positionMethodFailureCause [5] PositionMethodFailure- Diagnostic, -- See TS 29.002 unauthorizedLCSCClientCause [6] UnauthorizedLCSCClient- Diagnostic -- See TS 29.002 } PositionMethodFailure-Diagnostic ::= ENUMERATED { congestion (0), insufficientMeasurementData (2), inconsistentMeasurementData (3), locationProcedureNotCompleted (4), locationProcedureNotSupportedByTargetMS (5), qoSNotAttainable (6), positionMethodNotAvailableInNetwork (7), positionMethodNotAvailableInLocationArea (8), ... } UnauthorizedLCSCClient-Diagnostic ::= ENUMERATED { noAdditionalInformation (0), clientNotInMSPrivacyExceptionList (1), callToClientNotSetup (2), privacyOverrideNotApplicable (3), disallowedByLocalRegulatoryRequirements (4), ... } </pre>

Table B-41 (Cont.) SMSResult/Diagnostics Field Versions

Version	Definition
V6.4.1	<pre> SMSResult ::= Diagnostics itu-tQ767Cause [2] INTEGER, Diagnostics ::= CHOICE { gsm0408Cause [0] INTEGER, -- See TS 24.008 gsm0902MapErrorValue [1] INTEGER, -- See ITU-T Q.767 networkSpecificCause [3] ManagementExtension, clientNotInMSPrivacyExceptionList (1), manufacturerSpecificCause [4] ManagementExtension, -- To be defined by network operator -- To be defined by manufacturer positionMethodFailureCause [5] PositionMethodFailure- Diagnostic, unauthorizedLCSCClientCause [6] UnauthorizedLCSCClient- Diagnostic -- See TS 29.002 -- See TS 29.002 } PositionMethodFailure-Diagnostic ::= ENUMERATED { congestion (0), insufficientResources (1), insufficientMeasurementData (2), inconsistentMeasurementData (3), locationProcedureNotCompleted (4), locationProcedureNotSupportedByTargetMS (5), qoSNotAttainable (6), positionMethodNotAvailableInNetwork (7), positionMethodNotAvailableInLocationArea (8), ... } UnauthorizedLCSCClient-Diagnostic ::= ENUMERATED { noAdditionalInformation (0), callToClientNotSetup (2), privacyOverrideNotApplicable (3), disallowedByLocalRegulatoryRequirements (4), ... } </pre>

Table B-41 (Cont.) SMSResult/Diagnostics Field Versions

Version	Definition
V3.6.0	<pre> SMSResult ::= Diagnostics ccittQ767Cause [2] INTEGER, Diagnostics ::= CHOICE { gsm0408Cause [0] INTEGER, -- See TS 24.008 gsm0902MapErrorValue [1] INTEGER, -- See ITU-T Q.767 networkSpecificCause [3] ManagementExtension, ccittQ767Cause [2] INTEGER, manufacturerSpecificCause [4] ManagementExtension -- To be defined by network operator -- To be defined by manufacturer } </pre>
V3.2.0	<pre> SMSResult ::= Diagnostics Diagnostics ::= CHOICE { gsm0408Cause [0] INTEGER, -- See TS 24.008 gsm0902MapErrorValue [1] INTEGER, -- See ITU-T Q.767 networkSpecificCause [3] ManagementExtension, { manufacturerSpecificCause [4] ManagementExtension -- To be defined by network operator -- To be defined by manufacturer } </pre>

[Table B-42](#) lists the versions that support version hiding.

Table B-42 SMSResult/Diagnostics Field Version Hiding

Version hiding	Changed fields	Changes
7.3.0 to 6.4.1	None.	No changes.

Table B-42 (Cont.) SMSResult/Diagnostics Field Version Hiding

Version hiding	Changed fields	Changes
7.3.0 to 3.6.0	None.	No changes.
6.4.1 to 3.6.0	If the choice is itu-tQ767Cause, translate it into ccittQ767Cause. If the choice is either positionMethodFailureCause or unauthorizedLCSCClientCause, drop the field (not supported in V3.6.0). Any other choices, output it as is.	N/A

RatingGroupId Field

[Table B-43](#) lists the definitions for RatingGroupId field versions.

Table B-43 RatingGroupId Field Versions

Version	Definition
v16.4.1	RatingGroupId ::= INTEGER
v10.5	RatingGroupId ::= INTEGER
v7.3.0	RatingGroup ::= INTEGER
v6.4.1	RatingGroup ::= INTEGER

[Table B-44](#) lists the versions that support version hiding.

Table B-44 RatingGroupId Field Version Hiding

Version hiding	Changed fields	Changes
16.4.1 to 10.5	No change.	No change.
10.5 to 7.3.0	The field name is RatingGroup in 7.3.0.	Should be put out as RatingGroup in the record.
10.5 to 6.4.1	The field name is RatingGroup in 6.4.1.	Should be put out as RatingGroup in the record.

ServiceConditionChange Field

[Table B-45](#) lists the definitions for ServiceConditionChange field versions.

Table B-45 ServiceConditionChange Field Versions

Version	Definition
v16.4.1	<pre> ServiceConditionChange ::= BIT STRING qoSChange (0), -- bearer modification sGSNChange (1), -- bearer modification sGSNPLMNIDChange (2), -- bearer modification tariffTimeSwitch (3), -- tariff time change pDPCContextRelease (4), -- bearer release rATChange (5), -- bearer modification serviceIdledOut (6), -- IP flow idle out, DCCA QHT expiry reserved (7), -- old: QCTexpiry is no report event configurationChange (8), -- configuration change serviceStop (9), -- IP flow termination. From "Service Stop" in -- Change-Condition" AVP dCCATimeThresholdReached (10), -- DCCA quota reauthorization dCCAVolumeThresholdReached (11), -- DCCA quota reauthorization dCCAServiceSpecificUnitThresholdReached (12), -- DCCA quota reauthorization dCCATimeExhausted (13), -- DCCA quota reauthorization dCCAVolumeExhausted (14), -- DCCA quota reauthorization dCCAValityTimeout (15), -- DCCA quota validity time (QVT expiry) reserved1 (16), -- reserved due to no use case, -- old: return Requested is covered by (17),(18) dCCAReauthorisationRequest (17), -- DCCA quota reauthorization request by OCS dCCAContinueOngoingSession (18), -- DCCA failure handling (CCFH), -- continue IP flow dCCARetryAndTerminateOngoingSession (19), -- DCCA failure handling (CCFH), -- terminate IP flow after DCCA retry dCCATerminateOngoingSession (20), -- DCCA failure handling, -- terminate IP flow cGI-SAIChange (21), -- bearer modification. "CGI-SAI Change" </pre>

Table B-45 (Cont.) ServiceConditionChange Field Versions

Version	Definition
	<pre> rAIChange (22), -- bearer modification. "RAI Change" dCCAServiceSpecificUnitExhausted (23), -- DCCA quota reauthorization recordClosure (24), -- PGW-CDR closure timeLimit (25), -- intermediate recording. From "Service Data -- Time Limit" Change-Condition AVP value volumeLimit (26), -- intermediate recording.From "Service Data -- Volume Limit" Change-Condition AVP value serviceSpecificUnitLimit (27), -- intermediate recording envelopeClosure (28), eCGIChange (29), -- bearer modification. "ECGI Change" tAIChange (30), -- bearer modification. "TAI Change" userLocationChange (31), -- bearer modification. "User Location Change" userCSGInformationChange (32), -- bearer modification. "User CSG info Change" presenceInPRACHange (33), -- bearer modification. "Change of UE Presence in Presence Reporting Area" accessChangeOfSDF (34), -- "access change of service data flow" indirectServiceConditionChange (35), -- NBIFOM: "indirect service condition change" servingPLMNRateControlChange (36), -- bearer modification. "Serving PLMNRate Control Change" aPNRateControlChange (37) -- bearermodification. "APN Rate Control Change" } </pre>

Table B-45 (Cont.) ServiceConditionChange Field Versions

Version	Definition
v10.5	<pre> ServiceConditionChange ::= BIT STRING goSChange (0), -- bearer modification sGSNChange (1), -- bearer modification sGSNPLMNIDChange (2), -- bearer modification tariffTimeSwitch (3), -- tariff time change pDPCContextRelease (4), -- bearer release rATChange (5), -- bearer modification serviceIdledOut (6), -- IP flow idle out, DCCA QHT expiry reserved (7), -- old: QCTexpiry is no report event configurationChange (8), -- configuration change serviceStop (9), -- IP flow termination. From "Service Stop" in -- Change-Condition" AVP dCCATimeThresholdReached (10), -- DCCA quota reauthorization dCCAVolumeThresholdReached (11), -- DCCA quota reauthorization dCCAServiceSpecificUnitThresholdReached (12), -- DCCA quota reauthorization dCCATimeExhausted (13), -- DCCA quota reauthorization dCCAVolumeExhausted (14), -- DCCA quota reauthorization dCCAValidityTimeout (15), -- DCCA quota validity time (QVT expiry) reserved1 (16), -- reserved due to no use case, -- old: return Requested is covered by (17),(18) dCCAReauthorisationRequest (17), -- DCCA quota reauthorization request by OCS dCCAContinueOngoingSession (18), -- DCCA failure handling (CCFH), -- continue IP flow dCCARetryAndTerminateOngoingSession (19), -- DCCA failure handling (CCFH), -- terminate IP flow after DCCA retry dCCATerminateOngoingSession (20), -- DCCA failure handling, -- terminate IP flow cGI-SAIChange (21), -- bearer modification. "CGI-SAI Change" </pre>

Table B-45 (Cont.) ServiceConditionChange Field Versions

Version	Definition
	<pre> rAIChange (22), -- bearer modification. "RAI Change" dCCAServiceSpecificUnitExhausted (23), -- DCCA quota reauthorization recordClosure (24), -- PGW-CDR closure timeLimit (25), -- intermediate recording. From "Service Data -- Time Limit" Change-Condition AVP value volumeLimit (26), -- intermediate recording.From "Service Data -- Volume Limit" Change-Condition AVP value serviceSpecificUnitLimit (27), -- intermediate recording envelopeClosure (28), eCGIChange (29), -- bearer modification. "ECGI Change" tAIChange (30), -- bearer modification. "TAI Change" userLocationChange (31) -- bearer modification. "User Location Change" } </pre>

Table B-45 (Cont.) ServiceConditionChange Field Versions

Version	Definition
v7.3.0	<pre> ServiceConditionChange ::= BIT STRING { qosChange (0), -- PDP context modification sGSNChange (1), -- PDP context modification sGSNPLMNIDChange (2), -- PDP context modification tariffTimeSwitch (3), -- tariff time change pdpContextRelease (4), -- PDP context release rATChange (5), -- PDP context modification serviceIdledOut (6), -- IP flow idle out, DCCA QHT expiry reserved (7), -- old: QCTexpiry is no report event configurationChange (8), -- configuration change serviceStop (9), -- IP flow termination dccaTimeThresholdReached (10), -- DCCA quota reauthorization dccaVolumeThresholdReached (11), -- DCCA quota reauthorization dccaServiceSpecificUnitThresholdReached (12), -- DCCA quota reauthorization dccaTimeExhausted (13), -- DCCA quota reauthorization dccaVolumeExhausted (14), -- DCCA quota reauthorization dccaValidityTimeout (15), -- DCCA quota validity time (QVT expiry) reserved (16), -- reserved due to no use case -- old: return Requested is covered by (17),(18) dccaReauthorisationRequest (17), -- DCCA quota reauthorization request by OCS dccaContinueOngoingSession (18), -- DCCA failure handling (CCFH), -- continue IP flow dccaRetryAndTerminateOngoingSession (19), -- DCCA failure handling (CCFH), -- terminate IP flow after DCCA retry dccaTerminateOngoingSession (20), -- DCCA failure handling, -- terminate IP flow cgi-SAChange (21), -- PDP context modification rAIChange </pre>

Table B-45 (Cont.) ServiceConditionChange Field Versions

Version	Definition
	<pre> (22), -- PDP context modification dCCAServiceSpecificUnitExhausted (23), -- DCCA quota reauthorization recordClosure (24), -- eG-CDR closure timeLimit (25), -- intermediate recording volumeLimit (26), -- intermediate recording serviceSpecificUnitLimit (27), -- intermediate recording envelopeClosure } (28) </pre>
v6.4.1	<pre> ServiceConditionChange ::= BIT STRING qoSChange (0), sGSNChange (1), sGSNPLMNIDChange (2), tariffTimeSwitch (3), pDPContextRelease (4), rATChange (5), serviceIdledOut (6), qCTExpiry (7), configurationChange (8), serviceStop (9), timeThresholdReached (10), volumeThresholdReached (11), timeExhausted (13), volumeExhausted (14), timeout (15), returnRequested (16), reauthorisationRequest (17), continueOngoingSession (18), retryAndTerminateOngoingSession (19), terminateOngoingSession (20) } </pre>

[Table B-46](#) lists the versions that support version hiding.

Table B-46 ServiceConditionChange Field Version Hiding

Version hiding	Changed fields	Changes
10.5 to 7.3.0	New bit values added in 10.5.	Bits after 28 are set to zero.
10.5 to 6.4.1	New bit values added in 10.5.	Bits after 20 are set to zero.

ServingNodeType Field

[Table B-47](#) lists the definitions for ServingNodeType field versions.

Table B-47 ServingNodeType Versions

Version	Definition
v16.4.1	<pre>ServingNodeType ::= ENUMERATED { sGSN (0), pMIPSGW (1), gTPSGW (2), ePDG (3), hSGW (4), mME (5), tWAN (6) }</pre>
v10.5	<pre>ServingNodeType ::= ENUMERATED { sGSN (0), pMIPSGW (1), gTPSGW (2), ePDG (3), hSGW (4), mME (5) }</pre>
v7.3.0	Not Present
v6.4.1	Not Present

[Table B-48](#) lists the versions that support version hiding.

Table B-48 ServingNodeType Version Hiding

Version hiding	Changed fields	Changes
10.5 to 7.3.0	The field is not present in 7.3.0 definition supported Out of Box.	The field will be omitted from the output record.
10.5 to 6.4.1	The field is not present in 6.4.1 specification.	The field will be omitted from the output record.

SGWChange Field

[Table B-49](#) lists the definitions for SGWChange field versions.

Table B-49 SGWChange Field Versions

Version	Definition
v16.4.1	<pre>SGWChange ::= BOOLEAN</pre>
v10.5	<pre>SGWChange ::= BOOLEAN</pre>

Table B-49 (Cont.) SGWChange Field Versions

Version	Definition
v7.3.0	Not Present
v6.4.1	Not Present

[Table B-50](#) lists the versions that support version hiding.

Table B-50 SGWChange Field Version Hiding

Version hiding	Changed fields	Changes
10.5 to 7.3.0	The field is not present in 7.3.0 definition supported Out of Box.	The field will be omitted from the output record.
10.5 to 6.4.1	The field is not present in 6.4.1 specification.	The field will be omitted from the output record.

TimeQuotaMechanism Field

[Table B-51](#) lists the definitions for TimeQuotaMechanism field versions.

Table B-51 TimeQuotaMechanism Field Versions

Version	Definition
v16.4.1	<pre>TimeQuotaMechanism ::= SEQUENCE timeQuotaType [1] TimeQuotaType, baseTimeInterval [2] Integer }</pre>
v10.5	<pre>TimeQuotaMechanism ::= SEQUENCE timeQuotaType [1] TimeQuotaType, baseTimeInterval [2] Integer }</pre>
v7.3.0	<pre>TimeQuotaMechanism ::= SEQUENCE { timeQuotaType [1] TimeQuotaType, baseTimeInterval [2] Integer }</pre>
v6.4.1	Not Present {

[Table B-52](#) lists the versions that support version hiding.

Table B-52 TimeQuotaMechanism Field Version Hiding

Version hiding	Changed fields	Changes
10.5 to 7.3.0	No Change	Do nothing. The new value defined in V10.5 will be output in V7.3.0.
10.5 to 6.4.1	The field is not present in 6.4.1 specification.	The field will be omitted from the output record.

TimeQuotaType Field

[Table B-53](#) lists the definitions for TimeQuotaType field versions.

Table B-53 TimeQuotaType Field Versions

Version	Definition
v16.4.1	<pre>TimeQuotaType ::= ENUMERATED { dISCRETETIMEPERIOD (0), cONTINUOUSTIMEPERIOD (1) }</pre>
v10.5	<pre>TimeQuotaType ::= ENUMERATED { dISCRETETIMEPERIOD (0), cONTINUOUSTIMEPERIOD (1) }</pre>
v7.3.0	<pre>TimeQuotaType ::= ENUMERATED { dISCRETETIMEPERIOD (0), cONTINUOUSTIMEPERIOD (1) }</pre>
v6.4.1	<pre>Not Present {</pre>

[Table B-54](#) lists the versions that support version hiding.

Table B-54 TimeQuotaType Field Version Hiding

Version hiding	Changed fields	Changes
16.4.1 to 10.5	No change.	Do nothing. The new value defined in v16.4.1 will be output in v10.5.
10.5 to 7.3.0	No change.	Do nothing. The new value defined in v10.5 will be output in v7.3.0.

Table B-54 (Cont.) TimeQuotaType Field Version Hiding

Version hiding	Changed fields	Changes
10.5 to 6.4.1	The field is not present in 6.4.1 specification.	The field will be omitted from the output record.

UserCSGInformation Field

[Table B-55](#) lists the definitions for UserCSGInformation field versions.

Table B-55 UserCSGInformation Field Versions

Version	Definition
v16.4.1	<pre>UserCSGInformation ::= SEQUENCE cSGId [0] CSGId, CSGAccessMode [1] CSGAccessMode, cSGMembershipIndication [2] NULL OPTIONAL }</pre>
v10.5	<pre>UserCSGInformation ::= SEQUENCE cSGId [0] CSGId, CSGAccessMode [1] CSGAccessMode, cSGMembershipIndication [2] NULL OPTIONAL }</pre>
v7.3.0	Not Present --
v6.4.1	Not Present

[Table B-56](#) lists the versions that support version hiding.

Table B-56 UserCSGInformation Field Version Hiding

Version hiding	Changed fields	Changes
16.4.1 to 10.5	No change.	No change.
10.5 to 7.3.0	The field is not present in 7.3.0 definition supported Out of Box.	The field will be omitted from the output record.
10.5 to 6.4.1	The field is not present in 6.4.1 specification.	The field will be omitted from the output record.

ChangeLocation Field

[Table B-57](#) lists the definitions for ChangeLocation field versions.

Table B-57 ChangeLocation Field Versions

Version	Definition
v16.4.1	<pre> ChangeLocation ::= SEQUENCE -- used in SGSNMMRecord only -- { LocationAreaCode, locationAreaCode [0] RoutingAreaCode, routingAreaCode [1] OPTIONAL, cellId [2] CellId TimeStamp, changeTime [3] OPTIONAL, mCC-MNC [4] PLMN-Id } </pre>
v10.5	<pre> ChangeLocation ::= SEQUENCE -- used in SGSNMMRecord only -- { LocationAreaCode, locationAreaCode [0] RoutingAreaCode, routingAreaCode [1] OPTIONAL, cellId [2] CellId TimeStamp, changeTime [3] OPTIONAL, mCC-MNC [4] PLMN-Id } </pre>
v7.3.0	<pre> ChangeLocation ::= SEQUENCE { -- -- used in SGSNMMRecord only -- LocationAreaCode, locationAreaCode [0] RoutingAreaCode, routingAreaCode [1] OPTIONAL, cellId [2] CellId TimeStamp, changeTime [3] OPTIONAL, mCC-MNC [4] PLMN-Id } </pre>

Table B-57 (Cont.) ChangeLocation Field Versions

Version	Definition
v6.4.1	<pre> ChangeLocation ::= SEQUENCE { -- -- used in SGSNMMRecord only -- locationAreaCode [0] LocationAreaCode, routingAreaCode [1] RoutingAreaCode, cellId [2] CellId OPTIONAL, changeTime [3] TimeStamp } </pre>

[Table B-58](#) lists the versions that support version hiding.

Table B-58 ChangeLocation Field Version Hiding

Version hiding	Changed fields	Changes
16.4.1 to 10.5	No changes.	Do nothing. The new value defined in v16.4.1 will be output in v10.5.0.
10.5 to 7.3.0	No changes.	Do nothing. The new value defined in v10.5 will be output in v7.3.0.
10.5 to 6.4.1	New values added in 10.5.	Do nothing. The new value defined in v10.5 will be output in v6.4.1.

All Other Fields

There are no other changes between v16.4.1 and v10.5.0, v10.5.0 and v7.3.0, v10.5.0 and v6.4.1, and v7.3.0 and v6.4.1.

v7.3.0 and v6.4.1 still need to apply the entire existing version hiding functions (between v6.4.1 and v3.6.0) for v3.6.0.

For the different versions of the Nortel CBB (recordExtensions), nothing will be done in terms of version hiding between v7.3.0, v6.4.1, v3.6.0, and v3.2.0. The field recordExtensions will be passed through and output as is.

C

Offline Mediation Controller Support for 5G Non-Standalone Architecture

This appendix describes the additional attribute-value pairs (AVPs) supported by Oracle Communications Offline Mediation Controller SGSN/GGSN Cartridges (Packet Core Cartridge Bundle) for supporting 5G non-standalone architecture (NSA). This is in-compliance with the 3GPP TS 32.298 V16.4.1 for the AVPs mentioned in this appendix.

Topics in this document:

- [Extended Attributes in EPCQoSInformation AVP](#)
- [RANSecondaryRATUsageReport AVP](#)

Extended Attributes in EPCQoSInformation AVP

The EPCQoSInformation AVP includes the following extended attributes to support information from 5G system:

```
EPCQoSInformation ::= SEQUENCE
{
    qCI [1] INTEGER,
    maxRequestedBandwidthUL [2] INTEGER OPTIONAL,
    maxRequestedBandwidthDL [3] INTEGER OPTIONAL,
    guaranteedBitrateUL [4] INTEGER OPTIONAL,
    guaranteedBitrateDL [5] INTEGER OPTIONAL,
    arp [6] INTEGER OPTIONAL,
    apNAggregateMaxBitrateUL [7] INTEGER OPTIONAL,
    apNAggregateMaxBitrateDL [8] INTEGER OPTIONAL,

    -- Extended AVPs Start
    extendedMaxRequestedBWUL [9] INTEGER OPTIONAL,
    extendedMaxRequestedBWDL [10] INTEGER OPTIONAL,
    extendedGBRUL [11] INTEGER OPTIONAL,
    extendedGBRDL [12] INTEGER OPTIONAL,
    extendedAPNAMBRUL [13] INTEGER OPTIONAL,
    extendedAPNAMBRDL [14] INTEGER OPTIONAL
    -- Extended AVPs End
}
```

RANSecondaryRATUsageReport AVP

The PGW and SGW records include a sequence of *RANSecondaryRATUsageReport* for supporting charging 5G usage through P-Gateway and S-Gateway:

```
SGWRecord ::= SET
{
    ...
}
```

```

        listOfRANSecondaryRATUsageReports [64] SEQUENCE OF
RANSecondaryRATUsageReport OPTIONAL
    ...
}

PGWRecord ::= SET
{
    ...
    listOfRANSecondaryRATUsageReports [73] SEQUENCE OF
RANSecondaryRATUsageReport OPTIONAL
    ...
}

```

The *RANSecondaryRATUsageReport* AVP is of type SEQUENCE. This contains the volume count as reported by the RAN for the secondary RAT (separated for uplink and downlink) for the bearer including the time of the report:

```

RANSecondaryRATUsageReport ::= SEQUENCE
--
{
    dataVolumeUplink      [1] DataVolumeGPRS,
    dataVolumeDownlink    [2] DataVolumeGPRS,
    rANStartTime          [3] TimeStamp,
    rANEndTime            [4] TimeStamp,
    secondaryRATType      [5] SecondaryRATType OPTIONAL,
    chargingID            [6] ChargingID OPTIONAL
}

```

D

Nortel GSM/UMTS AMA Cartridge Pack Supported GSM Releases and Version Hiding

This appendix describes the supported GSM releases and version hiding in Oracle Communications Offline Mediation Controller Nortel GSM/UMTS AMA Cartridge Pack.

Topics in this document:

- [About the Supported GSM Versions](#)
- [Version Hiding For GSM 19 Data Fields](#)
- [Version Hiding For GSM 18 Data Fields](#)
- [Version Hiding For GSM 17 Data Fields](#)
- [Version Hiding For GSM 16 Data Fields](#)
- [Version Hiding For GSM 15 Data Fields](#)

About the Supported GSM Versions

This release supports GSM 13, 15, 16, 17, 18, and 19. In addition, one-to-one input and output file matching is supported for:

- GSM18 in -> GSM18 out
- GSM18 in -> GSM16 out
- GSM16 in -> GSM16 out
- GSM16 in -> GSM15 out
- GSM15 in -> GSM15 out

[Table D-1](#) lists the instances that support version hiding.

Table D-1 Version Hiding Instances

In: AMA DIRP	Out: AMA DIRP and NRTT
GSM 19	GSM 19
GSM 19	GSM 18
GSM 19	GSM 17
GSM 18	GSM 18
GSM 18	GSM 17
GSM 18	GSM 16
GSM 18	GSM 15
GSM 17	GSM 17
GSM 17	GSM 16
GSM 17	GSM 15

Table D-1 (Cont.) Version Hiding Instances

In: AMA DIRP	Out: AMA DIRP and NRTT
GSM 16	GSM 16
GSM 16	GSM 15
GSM 15	GSM 15
GSM 13	GSM 13
GSM 18	GSM 18
GSM 18	GSM 17
GSM 18	GSM 16
GSM 18	GSM 15
GSM 17	GSM 17
GSM 17	GSM 15
GSM 16	GSM 16
GSM 16	GSM 15
GSM 15	GSM 15

Note

GSM18 in -> GSM16 out and GSM16 in -> GSM15 out are supported only for Database.

[Table D-2](#) lists the instances that support version hiding.

Table D-2 Version Hiding Instances

In: AMA DIRP	Out: ASN.1
GSM 18	GSM 18
GSM 17	GSM 17
GSM 16	GSM 16
GSM 15	GSM 15
GSM 13	GSM 13

Version Hiding For GSM 19 Data Fields

[Table D-3](#) lists the GSM 19 data fields that support version hiding.

Table D-3 Version Hiding for GSM 19 Data Fields

Data Field	GSM 19	GSM 18	Version hiding GSM 19 to GSM 18	Version hiding GSM 19 to GSM 17
Called Equipment (or Served Equipment)	New Combination are supported 1-5 Values FFFFF 6-19 Values {0,1,2...9,A,B...F} 20-21 Values {0,1,2...9,A,B...F} 22 Value C	BCD/Hex string with 22 characters. There is no encoding	Contents are mapped directly (no version hiding).	Contents are mapped directly (no version hiding).
Called IMSI Number	New field in module MNP	Field is dropped	Field is dropped	Field is dropped
Calling Equipment (or Served Equipment)	New Combination are supported 1-5 Values FFFFF 6-19 Values {0,1,2...9,A,B...F} 20-21 Values {0,1,2...9,A,B...F} 22 Value C	BCD/Hex string with 22 character. There is no encoding	Contents are mapped directly (no version hiding)	Contents are mapped directly (no version hiding)
Post -Translated Called Party Number	New field in module GA	Field is dropped	Field is dropped	Field is dropped
Served IMEI	Character size is increased from 16 to 22. 1-5 Values FFFFF 6-19 Values {0,1,2...9,A,B...F} 20-21 Values {0,1,2...9,A,B...F} 22 Value C	BCD/Hex string with 16 characters. There is no encoding 15 values {0,1,2...9,A,B...F} 16 value C	Characters 1-4 and 20-21 are dropped	Field is dropped
SS Code (Supplementary Service Code)	New combinations are supported. New Value: Character 3 is F	This Combination is not introduced	If the value of SS Code is 0A1C , No action required. If the value of SS Code is 0FFC , Drop the module	If the value of SS Code is 0A1C , No action required. If the value of SS Code is 0FFC , Drop the module
Result Indicator	New combinations are supported. New Value: Character 2 - 3 is 59	This Combination is not introduced	Combination that is not supported mapped to '00'	Combination that is not supported mapped to '00'

Version Hiding For GSM 18 Data Fields

[Table D-4](#) lists the GSM 18 data fields that support version hiding.

Table D-4 Version Hiding for GSM 18 Data Fields

Data Field	Change	Version hiding GSM 18 to GSM 17	Version hiding GSM 18 to GSM 16	Version hiding GSM 18 to GSM 15
Calling / Called Subscriber Category	New combinations are supported. New values: 017-223,225,227, 229,231,233,235, 237,239,241,243, 245,247,249,251, 253,255	Combinations that are not supported are mapped to '000'.	Combinations that are not supported are mapped to '000'.	Combinations that are not supported are mapped to '000'.
Call Duration	Now contains 14 characters to capture additional information.	Characters 1 to 3 and 12 to 13 are dropped. Characters 4 to 10 map to characters 1 to 7, if character "1" has a value of "1". Otherwise, characters 5 to 11 map to characters 1 to 7.	Characters 1 to 3 and 12 to 13 are dropped. Characters 4 to 10 map to characters 1 to 7, if character "1" has a value of "1". Otherwise, characters 5 to 11 map to characters 1 to 7.	Characters 1 to 3 and 12 to 13 are dropped. Characters 4 to 10 map to characters 1 to 7, if character "1" has a value of "1". Otherwise, characters 5 to 11 map to characters 1 to 7.
Diagnostic / SMS Result	Character 0-1: value '01' is dropped.	Contents are mapped directly (no version hiding).	Protocol-Value "01" will be changed to "00".	Protocol-Value "01" will be changed to "00".
Equipment Identity	Only captures '00001' and '00002'. Otherwise set to 'FFFFF'.	Contents are mapped directly (no version hiding).	Contents are mapped directly (no version hiding).	Contents are mapped directly (no version hiding).
MSC/MGW Number	New mapping.	Field is mapped to MSC Number.	Field is mapped to MSC Number.	Field is mapped to MSC Number.
LCS Record Type	New values: '2' and '5'	Contents are mapped directly (no version hiding).	Record is dropped if field value is not equal to 1, 2, 3 or 4.	Record is dropped if field value is not equal to 1, 2, 3 or 4.
MSC Number	New field in structure code 0021. Composed of two field types: Numbering Plan Identifier and BCD or Full Hex String	Field is dropped in structure code 0021.	Field is dropped in structure code 0021.	Field is dropped in structure code 0021.
Identity Of Target UE	Field is dropped.	No change.	No change.	No change.
Served Party	New field in structure code.	Field maps to "Identity Of Target UE" field.	Field maps to "Identity Of Target UE" field.	Field maps to "Identity Of Target UE" field.
Served MSISDN	New field in structure code 0021. Composed of two field types: Numbering Plan Identifier and BCD or Full Hex String	Field is dropped in structure code 0021.	Field is dropped in structure code 0021.	Field is dropped in structure code 0021.

Table D-4 (Cont.) Version Hiding for GSM 18 Data Fields

Data Field	Change	Version hiding GSM 18 to GSM 17	Version hiding GSM 18 to GSM 16	Version hiding GSM 18 to GSM 15
Requesting Mobile Location Centre (MLC)	New field in structure code. Composed of two field types: Numbering Plan Identifier and BCD or Full Hex String	Field is dropped.	Field is dropped.	Field is dropped.
Privacy Notification	New field in structure code.	Field is dropped.	Field is dropped.	Field is dropped.
Privacy Override	New field in structure code.	Field is dropped.	Field is dropped.	Field is dropped.
Positioning Data	New field in structure code.	Field is dropped.	Field is dropped.	Field is dropped.
LCS Diagnostic	New field in structure code.	Field is dropped.	Field is dropped.	Field is dropped.
System Type	New field in structure code.	Field is dropped.	Field is dropped.	Field is dropped.
Served IMEI	New field in structure code.	Field is dropped.	Field is dropped.	Field is dropped.
Emergency Service Routing Digits (ESRD-Digits)	New field in structure code.	Field is dropped.	Field is dropped.	Field is dropped.
Emergency Service Routing Key (ESRK-Key)	New field in structure code.	Field is dropped.	Field is dropped.	Field is dropped.
LCS Priority Level	New field in structure code.	Field is dropped.	Field is dropped.	Field is dropped.
RNC ID	New field in module code.	Field is dropped.	Field is dropped.	Field is dropped.
Supplementary Services/ AoC Parameter/ Supplementary Service Code	New values: 'b0'	Value 'b0' mapped to default value '00'.	Value 'b0' mapped to default value '00'.	Value 'b0' mapped to default value '00'.
Operation Indication	New value: '6'	Value '6' mapped to default value '0'.	Value '6' mapped to default value '0'.	Value '6' mapped to default value '0'.
Patch Identity	New field in module code.	Field is dropped.	Field is dropped.	Field is dropped since module 28 is not supported.
Bearer Independent Core Network	New module.	Module is dropped.	Module is dropped.	Module is dropped.
BICN ModuleCode	New field in new module code.	Field is dropped.	Field is dropped.	Field is dropped.
BICN MGW Number	New field in new module code.	Field is dropped.	Field is dropped.	Field is dropped.

Table D-4 (Cont.) Version Hiding for GSM 18 Data Fields

Data Field	Change	Version hiding GSM 18 to GSM 17	Version hiding GSM 18 to GSM 16	Version hiding GSM 18 to GSM 15
BICN MGW Seizure Time	New field in new module code.	Field is dropped.	Field is dropped.	Field is dropped.
BICN Backbone Media Type	New field in new module code.	Field is dropped.	Field is dropped.	Field is dropped.
BICN Access Media Type	New field in new module code.	Field is dropped.	Field is dropped.	Field is dropped.
Ms Class Mark	Character 4: only captures value 0 to 4, and value '7' is dropped. Character 8,9,10,14 always set to 'F'.	Contents are mapped directly (no version hiding).	Characters 8 to 15 are dropped. If the character "2" has a value of "2", it is mapped to a value of "1". If the character "3" has a value of "1", it is mapped to a value of "0". If the character "4" has a value of "7", it is mapped to a value of "0". If the character "1" has a value of "1", then characters 5 and 6 are mapped to a value of "0". If the character "1" has a value of "2", then characters 5 and 6 are mapped as is. The character "7" is always mapped to a value of "0".	Characters 8 to 15 are dropped. If the character "2" has a value of "2", it is mapped to a value of "1". If the character "3" has a value of "1", it is mapped to a value of "0". If the character "4" has a value of "7", it is mapped to a value of "0". If the character "1" has a value of "1", then characters 5 and 6 are mapped to a value of "0". If the character "1" has a value of "2", then characters 5 and 6 are mapped as is. The character "7" is always mapped to a value of "0".
Supplementary Service Action	Captures value from '0' to '5'. Value '6' is dropped.	Contents are mapped directly (no version hiding).	Contents are mapped directly (no version hiding).	Contents are mapped directly (no version hiding).

Table D-4 (Cont.) Version Hiding for GSM 18 Data Fields

Data Field	Change	Version hiding GSM 18 to GSM 17	Version hiding GSM 18 to GSM 16	Version hiding GSM 18 to GSM 15
Channel Type	No Change.	Contents are mapped directly (no version hiding).	If Character 3 is equal to "0" and Character 1 is equal to "2" then the Data Rate Character (Character 4) value of "8" is mapped to value "0".	Channel Rate and Type Character (Character 2) values are mapped. If Character 1 has a value of "1", then the Character 2 values of 0, 1, 5, 6, 7, and 8 are mapped to "3". If Character 1 has a value of "2", then the Character 2 values of 0, 1, 5, 6, 7, and 8 are mapped to "4". If Character 1 has a value of "2", then the Character 2 values of 0, 1 and 5 are mapped to "3". If Character 1 has a value of "2" or "6" then the Character 2 values of 0, 1 and 5 are mapped to "4". If Character 3 has a value of "0" and Character 1 has a value of "2" then the Character 4 value of 8 is mapped to "0".
Module Code 9	No Change.	Contents are mapped directly (no version hiding).	Module Code is dropped for Structure Code 13, 14, 15 and 16.	Module Code is dropped for Structure Code 13, 14, 15 and 16.

Version Hiding For GSM 17 Data Fields

[Table D-5](#) lists the GSM 17 data fields that support version hiding.

Table D-5 Version Hiding for GSM 17 Data Fields

Data field	Change	Version hiding GSM 17 to GSM 16	Version hiding GSM 17 to GSM 15
Access Network	If the field is not present, the default value is now 0C.	Contents are mapped directly (no version hiding).	Contents are mapped directly.
Answer Time	Encoded using the new format for Date and Time field.	See Date and Time.	See Date and Time.

Table D-5 (Cont.) Version Hiding for GSM 17 Data Fields

Data field	Change	Version hiding GSM 17 to GSM 16	Version hiding GSM 17 to GSM 15
Call Type Code	Now includes value 003 - Location Update Call.	Structure codes with Call Type Code = 3 are dropped.	Structure codes with Call Type Code = 3 are dropped.
Carrier Connect Timestamp	Encoded using the new format for Date and Time field.	See Date and Time.	See Date and Time
Channel Allocation Time	Encoded using the new format for Date and Time field.	See Date and Time.	See Date and Time.
Correlation ID / ETC Parm2	New field.	Field is dropped.	Field is dropped.
CSI	CSI field can now capture a value for M-CSI information (value 7).	Contents are mapped directly (no version hiding).	Field is dropped.
Date and Time	Can now contain a time zone offset value: characters 14-15 hold the time zone offset.	Characters 14 and 15 set to 00.	Characters 14 and 15 set to 00.
Delivery Timestamp	Encoded using new format for Date and Time field.	See Date and Time.	See Date and Time.
Disconnect Time	Encoded using the new format for Date and Time field	See Date and Time.	See Date and Time.
Geographical Location of UE 1	Replaces Geographical Location of UE	This field maps to the Geographical Location of UE.	This field maps to the Geographical Location of UE.
Geographical Location of UE 2	New field	Field is dropped.	Field is dropped.
Geographical Location of UE 3	New field	Field is dropped.	Field is dropped.
Geographical Location of UE 4	New field	Field is dropped.	Field is dropped.
Geographical Location of UE 5	New field	Field is dropped.	Field is dropped.
IN Timestamp 1	Encoded using the new format for Date and Time field	See Date and Time.	See Date and Time.
IN Timestamp 2	Encoded using the new format for Date and Time field	See Date and Time.	See Date and Time.
Incoming/Outgoing Trunk Release Time	Encoded using the new format for Date and Time field	See Date and Time.	See Date and Time.
IC/INC Prefix	Now contains 10 characters to capture the carrier identification codes (CICs) for the Chinese market	Characters 1-8 map to characters 1-4 (truncation on left). Character 9 maps to character 5. Character 10 maps to character 6.	Characters 1-8 map to characters 1-4 (truncation on left). Character 9 maps to character 5. Character 10 maps to character 6.

Table D-5 (Cont.) Version Hiding for GSM 17 Data Fields

Data field	Change	Version hiding GSM 17 to GSM 16	Version hiding GSM 17 to GSM 15
IWF Activation Timestamp	Encoded using the new format for Date and Time field	See Date and Time.	See Date and Time.
LCS Client Identity	Composed of two field types: Numbering Plan Identifier and BCD or Full Hex String	Numbering Plan Identifier (first 6 characters) removed and replaced with default characters to make the field look like the 32 character field used in GSM 16. Characters 1-6 map to value 'FFFFFF' Characters 7 -32 map directly from GSM 17 characters 7-32.	Numbering Plan Identifier (first 6 characters) removed and replaced with default characters to make the field look like the 32 character field used in GSM 15. Characters 1-6 map to value 'FFFFFF' Characters 7-32 map directly from GSM 17 characters 7-32.
LCS Record Type	New supported value 5 represents MO-LR: Autonomous Self Location for Assistance Data	Value '5' mapped to default value 'F'.	Value '5' mapped to default value 'F'.
MM Event	New field	Field is dropped.	Field is dropped.
MS Classmark	Now contains 16 char to capture additional info	Character 7 set to '0'. Characters 8-15 dropped.	Char 7 always set to '0'. Char 8-15 dropped.
New AN	New field	Field is dropped.	Field is dropped.
New Cell - SAC Id	New field	Field is dropped.	Field is dropped.
New LAC	New field	Field is dropped.	Field is dropped.
New MSC Id	New field	Field is dropped.	Field is dropped.
Old AN	New field	Field is dropped.	Field is dropped.
Old Cell - SAC Id	New field	Field is dropped.	Field is dropped.
Old LAC	New field	Field is dropped.	Field is dropped.
Old MSC Id	New field	Field is dropped.	Field is dropped.
Record Count	New maximum value is 000065535.	Contents are mapped directly (no version hiding).	Field is dropped.
Record Header	Contains the new Release Id field, structure code 001 and call type code 003 for the location update record.	Release Id field dropped. Structure Code 0001 dropped. Call Type Code 003 dropped.	Release Id field dropped. Structure Code 0001 dropped. Call Type Code 003 dropped.
Recording Entity	New field.	Field is dropped.	Field is dropped.
Release Id	New field.	Field is dropped.	Field is dropped.
Release Time	Encoded using new format for Date and Time field.	See Date and Time.	See Date and Time.
SCF ID/ETC Parm1	New field.	Field is dropped.	Field is dropped.
Served MSISDN	New field.	Field is dropped.	Field is dropped.
Served IMSI	New field.	Field is dropped.	Field is dropped.

Table D-5 (Cont.) Version Hiding for GSM 17 Data Fields

Data field	Change	Version hiding GSM 17 to GSM 16	Version hiding GSM 17 to GSM 15
SMS Start Stamp	Encoded using new format for Date and Time field.	See Date and Time	See Date and Time.
SMS Stop Stamp	Encoded using new format for Date and Time field.	See Date and Time	See Date and Time.
SMS Time Stamp	Encoded using new format for Date and Time field.	See Date and Time	See Date and Time.
Structure Code	Contains new Location Update record.	Structure code 0001 is dropped.	Structure code 0001 is dropped.
SS Parameters field	Now 32 characters.	Truncation occurs from the left.	Same as GSM 17 - no change.
Unused Timestamp 1	Encoded using new format for Date and Time field.	See Date and Time.	See Date and Time.
Unused Timestamp 2	Encoded using new format for Date and Time field.	See Date and Time.	See Date and Time.
Update Result	New field.	Field is dropped.	Field is dropped.
Update Time	New field.	Field is dropped.	Field is dropped.

Version Hiding For GSM 16 Data Fields

[Table D-6](#) lists the GSM 16 data fields that support version hiding.

Table D-6 Version Hiding for GSM 16 Data Fields

Data field	Change	Version hiding GSM 16 to GSM 15
Called Number	New field in structure code.	Field is dropped.
Calling Number	New field in structure code.	Field is dropped.
Called/Calling Subscriber Category	New combinations are supported. New values: 224, 226, 228, 230, 234, 236, 238, 242, 246, 248, 250, 252, 254	Combinations that are not supported are mapped to '000'.
CAMEL Charging	Now allowed on structure code 4.	Module is dropped from illegal structures.
CAMEL SMS Info Module	New module.	Module is dropped.
CAMEL Subscriber Info	New field in module.	Field is dropped.
Channel Type	New combinations allowed.	If the 'Channel Rate and Type' field does not have a value of 3 or 4, this field will be set to 3.
CSI	New field.	Field is dropped.
Data Rate	Increased from two characters to four. Allowable range changed from 0-7 to 0-15.	Out of range values replaced with "007".

Table D-6 (Cont.) Version Hiding for GSM 16 Data Fields

Data field	Change	Version hiding GSM 16 to GSM 15
Free Format Data	Now 8 free-form fields with total payload of 336 characters. This is an increase from one field with 84 characters.	First and second field are mapped to accommodate 84-character field length.
Generic Address	Now allowed on structure codes 2, 3, 14, 16 and 18.	Module is dropped from illegal structures.
Generic Identity	New value=01600	GSM version specific value is substituted (i.e. 01500).
GSM Assisting SSP Info Module	New module.	Module is dropped.
IN Protocol	New field in module.	Field is dropped.
Local Ref Num	New field in module.	Field is dropped.
Patching Info Module	New module.	Module is dropped.
Rate Adaption	New field.	Field is dropped.
SMS Message Type	New field in structure code.	Field is dropped.
SMS Validity Period	New field in structure code.	Field is dropped.
SS Code	New value: 46	If SS Code = '046', entire Module Code 05 is dropped.

Version Hiding For GSM 15 Data Fields

[Table D-7](#) lists the GSM 15 data fields that support version hiding.

Table D-7 Version Hiding for GSM 15 Data Fields

Data field	Change	Version hiding GSM 15 to GSM 13
Access Network	New field.	Field is dropped.
Advice of Charge	New values: 02 and 03	Field is set to "00".
Call Reference	New range: 0-262143. (Old range was 0-65535).	Field is wrapped.
Call Type Code	New value: 17	Record is dropped.
Destination Routing Address	Increased from 22 to 32 characters.	Truncated from left.
Generic ID	New value: 01500	Version-specific value is substituted.
IAC	New structure code.	Record is dropped.
Location Services	New structure code.	Record is dropped.
Operation Indication	New value: 5	Field is set to "00".
Record Number	New range: 1-4294967295. (Old range was 1-9994239).	Field is wrapped.
SS Code	New values: 81 and A1.	Field is set to "00".

E

IMS CDF/CGF Cartridge Pack Output Specification

This appendix describes the Oracle Communications Offline Mediation Controller mapping for IMS CDF/CGF ECE cartridge.

Topics in this document:

- [Field Definition Notes](#)
- [Value Definitions for AVP Mapper EP Mapping Tables](#)
- [Media-Component-List Items](#)
- [List-of-Message-Bodies Items](#)
- [Early-SDP-Media-Description-List Items](#)
- [Real-Time-Tariff-Information Items](#)

The following tables display the mapping performed by the AVP Mapper EP as it converts diameter types to 32.298 ASN.1 format.

Field Definition Notes

The **incomplete-CDR-Indication** ASN.1 field is only outputted in the following cases:

- when the Stop record is received and records are missing
- or when the AP has not received a record for a given session within the configured Flush Time

The value for the **causeForRecordClosing** ASN.1 field is set according to the scenarios in [Table E-1](#):

Table E-1 causeForRecordClosing Values

Scenario	Field Value
Success case	serviceDeliveryEndSuccessfully
Error case 1 - AP Flush Time expires	timeLimit
Error case 2 - Stop or Event record received with a positive value for the Cause-Code	unSuccessfulServiceDelivery
Partial CDR generation	managementIntervention

Value Definitions for AVP Mapper EP Mapping Tables

- Assign - the value from each record received for a given session is used
- Assign last - the value from the last record received for a given session is used
- Assign first - the value from the first record received for a given session is used

- Append - the values from all records received for a given session are added to a list
- [Table E-2](#) lists the value definitions for AVP Mapper EP Mapping.

Table E-2 Value Definitions for AVP Mapper EP Mapping

ASN.1 IMSRecord	Diameter AVP [Code]	Aggregation Action	Translation Action
RecordType	Origin-Host [264]	Assign last	Assign
Retransmission	<Diameter Header> T-Flag	True if T-Flag received	Not Applicable
SIP-Method	Event-Type SIP-Method [824]	Assign last	Translate only for event records.
Role-of-Node	Role-of-Node [829]	Assign last	Assign
NodeAddress	Origin-Host [264]	Assign last	Assign to domainName choice of NodeAddress always
Session-Id	User-Session-ID [830]	Assign last	Assign
List-Of-Calling-Party-Address	Calling-Party-Address [831]	Append	Append without repeat
Called-Party-Address	Called-Party-Address [832]	Assign last	Assign by parsing URL.
PrivateUserID (S-CSCF only)	User-Name [1]	Assign last	Assign
ServiceRequestTimeStamp	SIP-Request-Timestamp [834] of ACR-Start	Assign first	Convert to binary 3GPP timestamp format
ServiceDeliveryStartTimeStamp	SIP-Response-Timestamp [835] of ACR-Start	Assign first	Convert to binary 3GPP timestamp format
ServiceDeliveryEndTimeStamp	SIP-Request-Timestamp [834] of ACR-Stop	Assign first	Convert to binary 3GPP timestamp format
RecordOpeningTime	N/A	AVP Mapper records time when first record was received	N/A
RecordClosingTime	N/A	AVP Mapper records time when record is last processed by AP	N/A
InterOperatorIdentifiers	Inter-Operator-Identifier [838] [839] [840]	Assign last	Assign
LocalRecordSequenceNumber	N/A	AP generates next serial number when record is first processed	N/A
RecordSequenceNumber	N/A	AP generates for every record received for a given session	N/A
CauseForRecordClosing	N/A	AP generates based on various conditions	N/A
Incomplete-CDR-Indication	N/A	AP generates based on various conditions	N/A
IMS-Charging-Identifier	IMS-Charging-Identifier [841]	Assign last	Convert from string to octets.

Table E-2 (Cont.) Value Definitions for AVP Mapper EP Mapping

ASN.1 IMSRecord	Diameter AVP [Code]	Aggregation Action	Translation Action
SDP-Session-Description	SDP-Session-Description [842]	Append	Assign, only keep strings that begin with "a=" or "c="
List-Of-SDP-Media-Components	SDP-Media-Description [845], SDP-Media-Name [844], SDP-Media-Description [842], GPRS-Charging-ID [2], SIP-Request-Timestamp [834], SIP-Response-Timestamp [835], Authorised-QoS [849]	Append - see below for how each field is handled	Assign (Complex)
GGSNAddress	GGSN-Address [847]	Assign last	Assign
ServiceDeliveryFailureReason	SIP-Method (224) Cause-Code [861]	Assign last	Assign
List-Of-Message-Bodies	Content-Type [826], Content-Disposition [828], Content-Length [827]	Append - see below for how each field is handled	Assign (Complex)
RecordExtensions	Not supported	Not supported	Not supported
ApplicationServersInformation (S-CSCF only)	Application-Server [836], Application-Provided-Called-Party-Address [837]	Append	Assign (Complex)
expiresInformation	Event-Type -> Expires [888]	AssignLast	Assign
List of Called Asserted Identity	Called-Asserted-Identity [1250]	Append	Assign
Number Portability Routing	Number-Portability-Routing-Information [2024]	Assign last	Assign
CarrierSelectRouting	Carrier-Select-Routing-Information[2023]	Assign last	Assign
List-Of-Associated-URI	Associated-URIs[856]	Append	Append without repeat, Assign by parsing URL.
ServiceContextID	Service-Context-Id[461]	Assign last	Assign
AccessNetworkInformation	Access-Network-Information[1263]	Assign last	Convert from string to octets.
IMSCommunicationServiceIdentifier	IMS-Communication-Service-Identifier[1281]	Assign last	Convert from string to octets.

Table E-2 (Cont.) Value Definitions for AVP Mapper EP Mapping

ASN.1 IMSRecord	Diameter AVP [Code]	Aggregation Action	Translation Action
IMSApplicationReferencelIdentifier	IMS-Application-Reference-Identifier[2601]	Assign last	Convert from string to octets.
OnlineChargingFlag	Online-Charging-Flag[2303]	Assign last	NULL if present
SessionPriority	Session-Priority[650]	Assign last	Assign
List-Of-Early-SDP-Media-Components	Early-Media-Description[1272]	Append	Append without repeat
List-Of-RealTimeTariffInformation	Real-Time-Tariff-Information[2305]	Append	Assign
userLocationInformation	User-Location-Info-Time[2812]	Assign last	Assign
iMSEmergencyIndicator	Emergency-Info[1687]	Assign last	Assign
iMSVisitedNetworkIdentifier	Visited-Network-Identifier[600]	Assign last	Assign
subscriberEquipmentNumber	User-Equipment-Info[458]	Assign last	Assign
servedPartyIPAddress	Served-Party-IP-Address[848]	Assign last	Assign
iMSVisitedNetworkIdentifier	Visited-Network-Identifier[600]	Assign last	Assign

Media-Component-List Items

[Table E-3](#) lists the Media-Component-List items.

Table E-3 Media Component List

ASN.1 IMSRecord	Diameter AVP [Code]	Aggregation Action	Translation Action
SIP-Request-Timestamp	SIP-Request-Timestamp [834]	Assign	Convert to binary 3gpp timestamp format
SIP-Response-Timestamp	SIP-Response-Timestamp [835]	Assign	Convert to binary 3gpp timestamp format
SDP-Media-Components : SDP-Media-Name	SDP-Media-Name [844]	Assign	Assign
SDP-Media-Components : SDP-Media-Descriptions	SDP-Media-Description [845]	Assign	Assign
SDP-Media-Components : GPRS-Charging-Id	GPRS-Charging-ID [2]	Assign	Assign
MediaInitiatorFlag	Media-Initiator-Flag [882]	Assign	Assign
SDP-Session-Description	SDP-Session-Description [842]	Assign	Assign
MediaInitiatorParty	Media-Initiator-Party[1288]	Assign	Assign

Table E-3 (Cont.) Media Component List

ASN.1 IMSRecord	Diameter AVP [Code]	Aggregation Action	Translation Action
SIP-Request-Timestamp-Fraction	SIP-Request-Timestamp-Fraction[2301]	Assign	Assign
SIP-Response-Timestamp-Fraction	SIP-Response-Timestamp-Fraction[2302]	Assign	Assign
SDP-Type	SDP-Type[2036]	Assign	Assign
LocalGWInsertedIndication	Local-GW-Inserted-Indication[2604]	Assign	Assign
IPRealmDefaultIndication	IP-Realm-Default-Indication[2603]	Assign	Assign

List-of-Message-Bodies Items

[Table E-4](#) lists the List-of-Message-Bodies items.

Table E-4 List of Message

ASN.1 IMSRecord	Diameter AVP [Code]	Aggregation Action	Translation Action
Content-Type	Event-Type Content-Type [826]	Assign	Assign
Content-Disposition	Event-Type Content-Disposition [828]	Assign	Assign
Content-Length	Event-Type Content-Length [827]	Assign	Convert from string to integer
Originator	Event-Type Content-Length [827]	Assign	Assign

Early-SDP-Media-Description-List Items

[Table E-5](#) lists the Early-SDP-Media-Description-List items.

Table E-5 Early SDP Media

ASN.1 IMSRecord	Diameter AVP [Code]	Aggregation Action	Translation Action
SDP-Offer-Timestamp	SDP-Timestamps: SDP-Offer-Timestamp[1274]	Assign	Assign
SDP-Answer-Timestamp	SDP-Timestamps: SDP-Answer-Timestamp[1275]	Assign	Assign
SDP-Media-Components : SDP-Media-Name	SDP-Media-Name [844]	Assign	Assign

Table E-5 (Cont.) Early SDP Media

ASN.1 IMSRecord	Diameter AVP [Code]	Aggregation Action	Translation Action
SDP-Media-Components : SDP-Media-Descriptions	SDP-Media-Description [845]	Assign	Assign
SDP-Media-Components : GPRS-Charging-Id	GPRS-Charging-ID [2]	Assign	Assign
MediaInitiatorFlag	Media-Initiator-Flag [882]	Assign	Assign
SDP-Session-Description	SDP-Session-Description [842]	Assign	Assign
SDP-Type	SDP-Type[2036]	Assign	Assign

Real-Time-Tariff-Information Items

[Table E-6](#) lists the Real-Time-Tariff-Information items.

Table E-6 Real-Time-Tariff

ASN.1 IMSRecord	Diameter AVP [Code]	Aggregation Action	Translation Action
TariffXML	Tariff-XML [2306]	Assign	Assign
TariffInformation { CurrencyCode, ScaleFactor, RateElements }	Tariff-Information [2060] { Current-Tariff[2056], Tariff-Time-Change[451], Next-Tariff[2057]}	Append to the List	Only Current Tariff information would be consumed from the Diameter Input.
TariffInformation: CurrencyCode	Tariff-Information:Current-Tariff:Currency-Code[425]	Assign	Assign
TariffInformation: ScaleFactor	Tariff-Information:Current-Tariff:Scale-Factor[2059]	Assign	Calculate the REAL value from the exponent and value-digits avps of Scale-Factor AVP.
TariffInformation: RateElement:UnitType	Tariff-Information:Current-Tariff:Rate-Element[2058]: CC-Unit-Type[454]	Assign	Assign
TariffInformation: RateElement:UnitValue	Tariff-Information:Current-Tariff:Rate-Element: Unit-Value[445]	Assign	Calculate the REAL value from the exponent and value-digits avps of Unit-Value AVP.
TariffInformation: RateElement:UnitCost	Tariff-Information:Current-Tariff:Rate-Element: Unit-Cost[2061]	Assign	Calculate the REAL value from the exponent and value-digits avps of Unit-Cost AVP.
TariffInformation: RateElement:UnitQuotaThres hold	Tariff-Information:Current-Tariff:Rate-Element: Unit-Quota-Threshold[1226]	Assign	Assign