

# Oracle® Communications Session Border Controller

## Accounting Guide



Release S-Cz9.2.0

F74354-04

February 2024

The Oracle logo, consisting of a solid red square with the word "ORACLE" in white, uppercase, sans-serif font centered within it.

ORACLE®

F74354-04

Copyright © 2023, 2024, Oracle and/or its affiliates.

This software and related documentation are provided under a license agreement containing restrictions on use and disclosure and are protected by intellectual property laws. Except as expressly permitted in your license agreement or allowed by law, you may not use, copy, reproduce, translate, broadcast, modify, license, transmit, distribute, exhibit, perform, publish, or display any part, in any form, or by any means. Reverse engineering, disassembly, or decompilation of this software, unless required by law for interoperability, is prohibited.

The information contained herein is subject to change without notice and is not warranted to be error-free. If you find any errors, please report them to us in writing.

If this is software, software documentation, data (as defined in the Federal Acquisition Regulation), or related documentation that is delivered to the U.S. Government or anyone licensing it on behalf of the U.S. Government, then the following notice is applicable:

U.S. GOVERNMENT END USERS: Oracle programs (including any operating system, integrated software, any programs embedded, installed, or activated on delivered hardware, and modifications of such programs) and Oracle computer documentation or other Oracle data delivered to or accessed by U.S. Government end users are "commercial computer software," "commercial computer software documentation," or "limited rights data" pursuant to the applicable Federal Acquisition Regulation and agency-specific supplemental regulations. As such, the use, reproduction, duplication, release, display, disclosure, modification, preparation of derivative works, and/or adaptation of i) Oracle programs (including any operating system, integrated software, any programs embedded, installed, or activated on delivered hardware, and modifications of such programs), ii) Oracle computer documentation and/or iii) other Oracle data, is subject to the rights and limitations specified in the license contained in the applicable contract. The terms governing the U.S. Government's use of Oracle cloud services are defined by the applicable contract for such services. No other rights are granted to the U.S. Government.

This software or hardware is developed for general use in a variety of information management applications. It is not developed or intended for use in any inherently dangerous applications, including applications that may create a risk of personal injury. If you use this software or hardware in dangerous applications, then you shall be responsible to take all appropriate fail-safe, backup, redundancy, and other measures to ensure its safe use. Oracle Corporation and its affiliates disclaim any liability for any damages caused by use of this software or hardware in dangerous applications.

Oracle®, Java, MySQL and NetSuite are registered trademarks of Oracle and/or its affiliates. Other names may be trademarks of their respective owners.

Intel and Intel Inside are trademarks or registered trademarks of Intel Corporation. All SPARC trademarks are used under license and are trademarks or registered trademarks of SPARC International, Inc. AMD, Epyc, and the AMD logo are trademarks or registered trademarks of Advanced Micro Devices. UNIX is a registered trademark of The Open Group.

This software or hardware and documentation may provide access to or information about content, products, and services from third parties. Oracle Corporation and its affiliates are not responsible for and expressly disclaim all warranties of any kind with respect to third-party content, products, and services unless otherwise set forth in an applicable agreement between you and Oracle. Oracle Corporation and its affiliates will not be responsible for any loss, costs, or damages incurred due to your access to or use of third-party content, products, or services, except as set forth in an applicable agreement between you and Oracle.

# Contents

## About this Guide

---

My Oracle Support x

## Revision History

---

## 1 Introduction to Accounting on the SBC

---

ACLI Instructions	1-2
Create an Account Configuration	1-2
Create Accounting Servers	1-3
RADIUS Account Server Prioritization	1-5

## 2 Call Signaling Accounting Configuration

---

Session Accounting	2-1
RADIUS Messages	2-1
Session Termination	2-2
Interim RADIUS Records for Recursive Attempts	2-3
SIP CDR Stop Time	2-3
ACLI Instructions and Examples	2-3
Media Stop Time VSA in CDRs	2-4
Media Stop Time VSAs	2-4
Media Stop Time Calculation	2-4
Millisecond Granularity for CDRs	2-5
Configure acct-session-time for millisecond granularity	2-5
SIP Call Tear Down Due to Media Guard Timer Expiration	2-5
Set Accounting Message Generation	2-6
Enhanced Stop CDR Reporting for Exceeded Ingress Session Constraints	2-7
Including P-Visited Network Identifier and History-Info Headers in CDRs	2-7
Including the Reason-Header AVP in CDRs	2-9
Configure the System to Add Reason Headers	2-13
Per Realm Accounting Control	2-13

ACLI Instructions	2-14
RADIUS CDR Content Control	2-15
Configuring Duplicate RADIUS Attribute Generation	2-15
Configuring Specific RADIUS Attributes for CDR Inclusion	2-15
Custom RADIUS CDR VSAs for SIP	2-16
About User-Defined VSAs for SIP Calls	2-16
HMR Adaptations	2-17
HMR String Variable	2-17
Configure User-Defined VSAs	2-18
ACLI Instructions String Variable	2-20
Trunk-Group VSA Generation	2-21
ACLI Instructions and Examples	2-21

### 3 RADIUS Accounting Management

---

Alarm Generation and Monitoring	3-1
RADIUS Alarms	3-1
Status and Statistics Monitoring	3-2
ACLI Show RADIUS Display	3-2

### 4 Local CDR Files and Push Receivers

---

Local CDR File Format	4-1
Local CDR File Format Consistency	4-1
Decoding Local CDR File Contents	4-2
Generate Local CDR Layout Files	4-2
Requirements	4-4
Local CDR File Naming Convention	4-4
Temporary File Naming for an Open CDR File	4-4
Operational Details	4-5
HA Considerations for CDR Output Redundancy	4-5
Call Detail Record Sequence Number in Filename	4-7
Local CDR File Storage Directories	4-7
Local CDR File Size and Rotation	4-7
Local CDR File Compression	4-8
Local CDR File Redundancy	4-8
Caveats for H.323	4-8
Configuring Local CDR Files	4-8
Local CDR File Delete Warning	4-9
Local CDR File Delete Alarm	4-10
Local CDR File Delete SNMP Trap	4-10

Local CDR Push Receivers	4-10
Secure FTP Push Configuration	4-10
Multiple Push Receivers	4-11
Deprecated ACLI Configuration	4-11
Configuring Local CDR Push Receivers	4-12
Monitoring CDR Push Receivers	4-13

## 5 CDR Attribute Reference

---

Standard RADIUS Attributes	5-1
Standard RADIUS Attributes Dictionary	5-2
RADIUS Accounting Termination Causes	5-3
Cisco Systems RADIUS Decodes	5-4
Oracle RADIUS VSAs	5-5
R-Factor and MOS	5-6
Media Flow Attributes	5-6
IPv6 Support	5-26
Oracle VSA Values	5-28
Authentication VSAs	5-31
RTP Traffic Reporting per Call	5-31
VoLTE and SMS VSAs	5-33
Distinct VoLTE Processes	5-36
Including P-Visited Network Identifier and History-Info Headers in CDRs	5-38
P-Asserted-ID Header Format in CDRs	5-40
Oracle RADIUS Acme-Extended-Attributes VSAs	5-41
MSRP Attributes	5-41
STIR/SHAKEN Attributes	5-42
Mappings and Disconnect Cause Values	5-45
SIP H.323 and Q.850 Mappings	5-45
SIP Status to H.323 Disconnect Reason Mapping	5-45
SIP Status to H.323 RAS Error Mapping	5-46
SIP Status to H.323 Release Complete Reason Error Mapping	5-46
Q.850 Cause to H.323 Release Complete Reason Mapping	5-47
SIP-SIP Calls	5-47
SIP-H.323 Calls with Interworking	5-48
SIP Events and Errors	5-48
H.323 Events and Errors	5-49
H.225 RAS Errors	5-49

## 6 Diameter Accounting

---

Diameter Accounting Messages	6-1
Resending ACRs	6-1
Postponement Feature	6-1
Call Flow Examples	6-1
ACR AVP Descriptions	6-3
Session-Id AVP (263)	6-3
Origin-Host AVP (264)	6-4
Origin-Realm AVP (296)	6-4
Destination-Realm AVP (283)	6-4
Destination-Host AVP (293)	6-4
Accounting-Record-Type AVP (480)	6-4
Accounting-Record-Number AVP (485)	6-4
Acct-Application-Id AVP (259)	6-6
User-Name AVP (1)	6-6
Event-Timestamp AVP (55)	6-6
Event-Type AVP (823)	6-6
Role-of-Node AVP (829)	6-7
User-Session-Id AVP (830)	6-7
Calling-Party-Address AVP (831)	6-7
Called-Party-Address AVP (832)	6-7
Time-Stamps AVP (833)	6-7
Inter-Operator-Identifier AVP (838)	6-7
SDP-Session-Description AVP (842)	6-8
Session-Media-Component AVP (845)	6-8
Cause AVP (860)	6-8
Reason-Header AVP (3401)	6-8
Values for Cause Code AVP (861)	6-9
STIR/SHAKEN AVPs	6-10
Stir-Signed-Request AVP (104)	6-10
Stir-Signed-Request-Exception-Id AVP (105)	6-11
Stir-Verified-Request AVP (106)	6-11
Stir-Verified-Request-Exception-Id AVP (107)	6-11
Stir-VS-Verstat (108)	6-12
Stir-VS-Reason (109)	6-13
Stir-TN-Used-For-AS-VS-Request (110)	6-13
Stir-Div-Signed-Request (111)	6-13
Stir-Div-Verified-Request (112)	6-14
ACR Event Records	6-14
ACR Event Message Construction	6-14

Event-Type AVP	6-14
Expires Value	6-15
Event ACRs Generated for Unsuccessful Session Attempts	6-15
Event ACRs Generated for Receipt of SIP Messages	6-17
Event ACRs for SMS	6-18
VoLTE Call and SMS AVPs for Diameter	6-20
Distinct VoLTE Processes	6-24
Event Local CSV File	6-26
Diameter Heartbeat for Rf	6-26
Using FQDNs to Access CCFs over Diameter	6-27
Handling Multiple CCFs	6-29
Accounting Traffic and Server Statistics	6-33
Configuring Diameter-based Accounting	6-37
Configure the Global Diameter-based Accounting (Rf) Features	6-37
Configure Accounting Servers	6-40
Create a Dictionary File for Decoding AVPs	6-42
Additional Rf Features Alarms and Traps	6-43
Service-Context-ID Format	6-43
Acme Excluded Attribute Range	6-43
Configure Account	6-44
SNMP Trap Behavior	6-44
Alarms	6-46
SNMP MIBs and Traps	6-46
ApDiamResultCode Textual Convention	6-46
apDiameterSrvrErrorResultTrap	6-47
apDiameterSrvrSuccessResultTrap	6-47
apDiamACCTResultObjectsGroup Object Group	6-48
apDiamACCTResultNotificationsGroup Notification Group	6-48
SNMP Varbind Definitions	6-48
Diameter Rf Charging Buffering and Storage	6-48
About Buffering	6-48
About Storage	6-49
Monitoring Storage Space	6-49
ACLI Instructions and Examples	6-49
SNMP	6-50
DIAMETER Rf Charging Failure & Recovery Detection	6-50
Associated Traps	6-50

## A RADIUS Dictionary Reference

---

## B Local CDR Table Layouts

---

Local CDR Start Record (RADIUS)	B-1
Local CDR Interim Record (RADIUS)	B-5
Local CDR Stop Record (RADIUS)	B-9
Local CDR Message Record for SMS (RADIUS)	B-14
Local CDR Start Record (Diameter)	B-16
Local CDR Interim Record (Diameter)	B-20
Local CDR Stop Record (Diameter)	B-26
Local CDR Message Record for SMS (Diameter)	B-32

## C Oracle Rf Interface Support

---

Diameter AVP Notation	C-1
Table Explanation	C-1
Root ACR Message Format	C-1
Service Information AVP	C-2
Subscription ID AVP	C-2
IMS Information AVP	C-2
Event-Type AVP	C-3
Time Stamps AVP	C-4
Inter-Operator-Identifier AVP	C-4
SDP-Media-Component AVP	C-4
Early-Media-Description AVP	C-4
SDP-Timestamps AVP	C-5
Message-Body AVP	C-5
Acme-Packet-Specific-Extension-Rf AVP	C-5
AVP Definitions	C-10
System Alarming Based on Received Result-Code (268) AVP	C-13
Interim ACR Message Creation Interval per Acct-Interim-Interval AVP	C-13



# About this Guide

## Overview

The Oracle Communications Session Border Controller Accounting Guide describes:

- A description of how to high level accounting configuration and how to configure one or more remote RADIUS servers, including a failover group of RADIUS serves
- A description of how RADIUS CDRs are populated for H.323 and SIP Calls, including accounting-specific features
- A brief section on managing the RADIUS accounting servers, including alarms and statistics
- Local CDR file format and push receivers
- A section on CDR attribute details
- Diameter-based Rf Accounting

The appendices in this publication include

- Inclusive local CDR layouts for generic calls, and at the 3 points of generation (stop, interim, start)
- Diameter Rf specification for supported AVPs

## Documentation Set

The following table describes the documentation set for this release.

Document Name	Document Description
Acme Packet 3900 Hardware Installation Guide	Contains information about the components and installation of the Acme Packet 3900.
Acme Packet 4600 Hardware Installation Guide	Contains information about the components and installation of the Acme Packet 4600.
Acme Packet 4900 Hardware Installation Guide	Contains information about the components and installation of the Acme Packet 3950 and Acme Packet 4900.
Acme Packet 6100 Hardware Installation Guide	Contains information about the components and installation of the Acme Packet 6100.
Acme Packet 6300 Hardware Installation Guide	Contains information about the components and installation of the Acme Packet 6300.
Acme Packet 6350 Hardware Installation Guide	Contains information about the components and installation of the Acme Packet 6350.
Release Notes	Contains information about the current documentation set release, including new features and management changes.
Known Issues & Caveats	Contains known issues and caveats

Document Name	Document Description
Configuration Guide	Contains information about the administration and software configuration of the Service Provider Session Border Controller (SBC).
ACLI Reference Guide	Contains explanations of how to use the ACLI, as an alphabetical listings and descriptions of all ACLI commands and configuration parameters.
Maintenance and Troubleshooting Guide	Contains information about SBC logs, performance announcements, system management, inventory management, upgrades, working with configurations, and managing backups and archives.
MIB Guide	Contains information about Management Information Base (MIBs), Oracle Communication's enterprise MIBs, general trap information, including specific details about standard traps and enterprise traps, Simple Network Management Protocol (SNMP) GET query information (including standard and enterprise SNMP GET query names, object identifier names and numbers, and descriptions), examples of scalar and table objects.
Accounting Guide	Contains information about the SBC's accounting support, including details about RADIUS and Diameter accounting.
HDR Guide	Contains information about the SBC's Historical Data Recording (HDR) feature. This guide includes HDR configuration and system-wide statistical information.
Admin Security Guide	Contains information about the SBC's support for its Administrative Security license.
Security Guide	Contains information about security considerations and best practices from a network and application security perspective for the SBC family of products.
Platform Preparation and Installation Guide	Contains information about upgrading system images and any pre-boot system provisioning.
Call Traffic Monitoring Guide	Contains information about traffic monitoring and packet traces as collected on the system. This guide also includes WebGUI configuration used for the SIP Monitor and Trace application.
HMR Guide	Contains information about configuring and using Header Manipulation Rules to manage service traffic.
REST API	Contains information about the supported REST APIs and how to use the REST API interface.

### Documentation Accessibility

For information about Oracle's commitment to accessibility, visit the Oracle Accessibility Program website at <http://www.oracle.com/pls/topic/lookup?ctx=acc&id=docacc>.

## My Oracle Support

My Oracle Support (<https://support.oracle.com>) is your initial point of contact for all product support and training needs. A representative at Customer Access Support (CAS) can assist you with My Oracle Support registration.

Call the CAS main number at 1-800-223-1711 (toll-free in the US), or call the Oracle Support hotline for your local country from the list at <http://www.oracle.com/us/support/contact/index.html>. When calling, make the selections in the sequence shown below on the Support telephone menu:

1. Select 2 for New Service Request.
2. Select 3 for Hardware, Networking, and Solaris Operating System Support.
3. Select one of the following options:
  - For technical issues such as creating a new Service Request (SR), select 1.
  - For non-technical issues such as registration or assistance with My Oracle Support, select 2.

You are connected to a live agent who can assist you with My Oracle Support registration and opening a support ticket.

My Oracle Support is available 24 hours a day, 7 days a week, 365 days a year.

### Emergency Response

In the event of a critical service situation, emergency response is offered by the Customer Access Support (CAS) main number at 1-800-223-1711 (toll-free in the US), or call the Oracle Support hotline for your local country from the list at <http://www.oracle.com/us/support/contact/index.html>. The emergency response provides immediate coverage, automatic escalation, and other features to ensure that the critical situation is resolved as rapidly as possible.

A critical situation is defined as a problem with the installed equipment that severely affects service, traffic, or maintenance capabilities, and requires immediate corrective action. Critical situations affect service and/or system operation resulting in one or several of these situations:

- A total system failure that results in loss of all transaction processing capability
- Significant reduction in system capacity or traffic handling capability
- Loss of the system's ability to perform automatic system reconfiguration
- Inability to restart a processor or the system
- Corruption of system databases that requires service affecting corrective actions
- Loss of access for maintenance or recovery operations
- Loss of the system ability to provide any required critical or major trouble notification

Any other problem severely affecting service, capacity/traffic, billing, and maintenance capabilities may be defined as critical by prior discussion and agreement with Oracle.

### Locate Product Documentation on the Oracle Help Center Site

Oracle Communications customer documentation is available on the web at the Oracle Help Center (OHC) site, <http://docs.oracle.com>. You do not have to register to access these documents. Viewing these files requires Adobe Acrobat Reader, which can be downloaded at <http://www.adobe.com>.

1. Access the Oracle Help Center site at <http://docs.oracle.com>.
2. Click **Industries**.

3. Under the Oracle Communications sub-header, click the **Oracle Communications documentation** link.  
The Communications Documentation page appears. Most products covered by these documentation sets appear under the headings "Network Session Delivery and Control Infrastructure" or "Platforms."
4. Click on your Product and then Release Number.  
A list of the entire documentation set for the selected product and release appears.
5. To download a file to your location, right-click the **PDF** link, select **Save target as** (or similar command based on your browser), and save to a local folder.

### **Access to Oracle Support**

Oracle customers that have purchased support have access to electronic support through My Oracle Support. For information, visit <http://www.oracle.com/pls/topic/lookup?ctx=acc&id=info> or visit <http://www.oracle.com/pls/topic/lookup?ctx=acc&id=trs> if you are hearing impaired.

# Revision History

This section provides a revision history for this document.

Date	Description
March 2023	<ul style="list-style-type: none"><li>Initial Release.</li></ul>
May 2023	<ul style="list-style-type: none"><li>Corrects the minimum value acceptable for file-rotate-time.</li><li>Updates Local CDR Push Receivers to include priority parameter.</li><li>Updates empty string scenarios for the STIR-VS-Verstat and STIR-VS-Reason AVPs.</li></ul>
December 2023	<ul style="list-style-type: none"><li>Corrects typographical errors in CDR table topics.</li><li>Corrects AVP type for Stir-VS-Verstat.</li><li>Corrects AVP order in Acme-Packet-Specific-Extension-Rf AVP table.</li><li>Corrects two RADIUS AVP names and descriptions.</li><li>Adds missing alarms and traps for ACRq buffer overflow and diameter server connection issues.</li></ul>
February 2024	<ul style="list-style-type: none"><li>Corrects description of SDP-Session-Description AVP.</li><li>Adds the Create Diameter Dictionary feature at S-Cz9.2.0p5.</li></ul>

# 1

## Introduction to Accounting on the SBC

RADIUS is an accounting, authentication, and authorization (AAA) system. In general, RADIUS servers are responsible for receiving user connection requests, authenticating users, and returning all configuration information necessary for the client to deliver service to the user. This document focuses on capturing call accounting data.

You can configure your SBC to send call accounting information to one or more RADIUS servers. This information can help you to see usage and QoS metrics, monitor traffic, and even troubleshoot your system. For more information about QoS, refer to the Admission Control and QoS chapter of the ACLI Configuration Guide.

Accounting data may also be written locally in a friendly CSV format in standard text files. You can automate systems to retrieve these files from the SBC's directories, or you can configure the SBC to SFTP the files at regular intervals to remote servers within your network.

Finally, accounting information may be relayed to servers, often in an VoLTE network, using the Rf charging interface which runs on the Diameter protocol. The SBC can output either RADIUS or Diameter based accounting information, but not both simultaneously.

### Licensing

In order to use RADIUS with your SBC, you must have the accounting license installed and activated on your system. For more information about licensing, see the Software Licensing section of the ACLI Configuration Guide's Getting Started chapter.

### Accounting Features

For H.323, SIP, and calls being interworked between H.323 and SIP (IWF), you can obtain records that contain information to help you with accounting and that provide a quantitative and qualitative measurement of the call. For H.323 and SIP calls, the SBC generates one set of records; for calls requiring IWF, the {Varref: productabbreviation} OCSBC generates two sets of records.

You can use the RADIUS records generated by your SBC to assist you with:

- Usage accounting—See the calling and called parties for a call, the protocol used, the realm the call traversed (as well as local and remote IP address and port information), and the codec used
- Traffic monitoring—You can see information about the setup, connect, and disconnect times, as well as the SIP or H.323 disconnect cause
- SLA monitoring—The SBC supports RADIUS attributes that provide information about jitter, latency, and loss for H.323, SIP, and calls that require interworking between H.323 and SIP
- Troubleshooting—Obtain information about calls that can help you to identify and address issues with quality and how calls are setup and torn down.

## ACLI Instructions

This section tells you how to access and set parameters for accounting support. To use the SBC with external RADIUS (accounting) servers to generate CDRs and provide billing services requires, you need to configure account configuration and one or more account servers.

### Create an Account Configuration

You set the account configuration parameters to define high level accounting information. After setting initial parameters in the account-config, you must create one or more accounting-servers that define the systems where RADIUS accounting CDRs are sent.

To configure the account configuration:

1. Access the **account-config** configuration element.

```
ORACLE# configure terminal
ORACLE(configure)# session-router
ORACLE(session-router)# account-config
ORACLE(account-config)#
```

2. **hostname**—Defaults to and must remain localhost.
3. **port**—Retain the default value of 1813 or enter the number of the UDP port associated with the SBC from which RADIUS messages are sent.
  - minimum: 1025
  - maximum: 65535
4. **strategy**—Indicate the strategy you want used to select the accounting servers to which the SBC will send its accounting messages. The following table lists the available strategies:
  - **hunt**—Selects accounting servers in the order in which they are listed. If the first accounting server is online, working, and has not exceeded any of the defined constraints, all traffic is sent to it. Otherwise the second accounting server is selected. If the first and second accounting servers are offline or exceed any defined constraints, the third accounting server is selected. And so on through the entire list of configured servers.
  - **failover**—Uses the first server in the list of predefined accounting servers until a failure is received from that server. Once a failure is received, it moves to the second accounting server in the list until a failure is received. And so on through the entire list of configured servers.
  - **round robin**—Selects each accounting server in order, distributing the selection of each accounting server evenly over time.
  - **fastest round trip time**—Selects the accounting server that has the fastest round trip time (RTT) observed during transactions with the servers (sending a record and receiving an ACK).
  - **fewest pending**—Selects the accounting server that has the fewest number of unacknowledged accounting messages (that are in transit to the SBC).

5. **protocol**—Retain the default value to use RADIUS accounting, or change this to **diameter**, for Diameter Rf charging.
6. **state**—Retain the default value **enabled** if you want the account configuration active on the system. Enter **disabled** if you do not want the account configuration active on the system.
7. **max-msg-delay**—Retain the default value of **60** seconds or indicate the length of time in seconds that you want the SBC to continue trying to send each accounting message. During this delay, the SBC can hold a generic queue of 4096 messages.
  - Minimum: zero (0)
  - Maximum: 4294967295
8. **max-wait-failover**—Retain the default value of **100** messages or indicate the maximum number of accounting messages the SBC can store its message waiting queue for a specific accounting server, before it is considered a failover situation.

Once this value is exceeded, the SBC attempts to send its accounting messages, including its pending messages, to the next accounting server in its configured list.

  - Minimum: one (1) message
  - Maximum: 4096 messages
9. **trans-at-close**—Retain the default value of **disabled** if you do not want to defer the transmission of message information to the close of a session. Enter **enabled** if you want to defer message transmission.
  - **disabled**—The SBC transmits accounting information at the start of a session (Start), during the session (Interim), and at the close of a session (Stop). The transmitted accounting information for a single session might span a period of hours and be spread out among different storage files.
  - **enabled**—Limits the number of files on the SBC used to store the accounting message information for one session. It is easiest to store the accounting information from a single session in a single storage file.
10. Type **done** to save your configuration.

Continue to the next section to create accounting servers.

## Create Accounting Servers

You must establish the list of servers which the SBC sends accounting messages. Create the account server list to store accounting server information for the account configuration. Each account server can hold 100 accounting messages. RADIUS will not work if you do not enter one or more servers in a list.

1. Access the **account-server** configuration element.

```
ORACLE# configure terminal
ORACLE(configure)# session-router
ORACLE(session-router)# account-config
ORACLE(account-config)# account-server
ORACLE(account-server)#
```

2. **hostname**—Add the host associated with the account server as an IP address.
3. **port**—Retain the default 1813 or enter the number of the UDP port associated with the account server to which RADIUS messages are sent.



- minimum: 1025
  - maximum: 65535
4. **state**—Retain the default enabled to enable the account servers on the system or enter disabled to disable them.
  5. **min-round-trip**—Retain the default 250 milliseconds or indicate the minimum round trip time of an accounting message.

- minimum: 10 milliseconds
- maximum: 5000 milliseconds

A round trip consists of the following:

- The SBC sends an accounting message to the account server.
- The account server processes this message and responds back to the SBC.

If the fastest RTT is the strategy for the account configuration, the value you enter here can be used to determine an order of preference (if all the configured account servers are responding in less than their minimum RTT).

6. **max-inactivity**—Retain the default 60 seconds or indicate the length of time in seconds that you want the SBC with pending accounting messages to wait when it has not received a valid response from the target account server.

- minimum: 1 second
- maximum: 300 seconds

Once this timer value is exceeded, the SBC marks the unresponsive account server as disabled in its failover scheme. When a server connection is marked as inactive, the SBC attempts to restart the connection and transfers pending messages to another queue for transmission. RADIUS messages might be moved between different account servers as servers become inactive or disabled.

7. **restart-delay**—Retain the default 30 seconds or indicate the length of time in seconds you want the SBC to wait before resending messages to a disabled account server.

- minimum: 1 second
- maximum: 300 seconds

8. **bundle-vs-a**—Retain the default enabled if you want the account server to bundle the VSAs within RADIUS accounting messages. Enter disabled if you do not want the VSAs to be bundled. (Bundling means including multiple VSAs within the vendor value portion of the message.)

In a bundled accounting message, the RADIUS message type is vendor-specific, the length is determined for each individual message, and the vendor portion begins with a 4-byte identifier, and includes multiple vendor type, vendor length, and vendor value attributes.

9. **secret**—Enter the secret passed from the account server to the client in text format. Transactions between the client and the RADIUS server are authenticated by the shared secret; which is determined by the source IPv4 address of the received packet.
10. **NAS-ID**—Optional. Enter the NAS ID in text format (FQDN allowed). The account server uses this value to identify the SBC for the transmittal of accounting messages.

The remote server to which the account configuration sends messages uses at least one of two potential pieces of information for purposes of identification. The SBC accounting messages always includes in the first of these:

- Network Access Server (NAS) IP address (the IP address of the SBC's SIP proxy)
- NAS ID (the second piece of information) provided by this value. If you enter a value here, the NAS ID is sent to the remote server.

If you have more than one SBC pointing to the same account server, the NAS ID can be used to identify which SBC generated the record.

11. **priority**—Enter the number corresponding to the priority you want this account server to have in relation to the other account servers to which you send traffic. The default for this parameter is 0, meaning the prioritization feature is turned off—and that the SBC will therefore prioritize accounting servers by IP address and port.

## RADIUS Account Server Prioritization

Especially useful for customers with multiple SBCs, the RADIUS account server prioritization feature allows you to assign a priority to each of the account servers you configure. Setting the priority for RADIUS accounting servers allows you to load balance traffic across the servers.

Without this feature, the SBC sorts RADIUS accounting servers by their IP addresses and ports. For example, if you have a pre-existing accounting server with the IP address and port combination of 10.1.31.2:1813 and then configure a new server at 10.0.3.12:2145, the new server will take priority over the pre-existing one. Of course, you always have the option of allowing the system to set the priority of your accounting servers in this way.

The prioritization feature works with all of the strategy types you set in the accounting configuration. However, it is most applicable to the **hunt** or **failover** strategies. You can assign a number to each server to mark its priority, or you can leave the priority parameter set to 0 (default) so the SBC prioritizes them by IP address and port.

# 2

## Call Signaling Accounting Configuration

This section explains SIP and H.323 accounting using the RADIUS Accounting System (RAS).

You can configure the SBC to modify and populate CDRs in specific ways. There are options for how a call proceeds with respect to start/stop/interim records, and the information contained within. This chapter lists features relating to your ability to customize the behavior of call data record population.

### Session Accounting

The RAS client can record SIP, H.323, and IWF session activity based on configuration and a CDR. The CDR determines which messages are generated and determines the RADIUS attributes included in the messages. The RAS client must be capable of sending CDRs to any number of RADIUS accounting servers, using the defined hunt, failover, round robin, fewest pending, or fastest server strategies.

The establishment, failed establishment, change, or removal of a session can trigger RADIUS Accounting Request messages. The RAS might also send notification of its status (enabled/disabled). RADIUS Accounting Request messages include the following:

- Start—Session has started.
- Interim-Update—Session parameters have changed.
- Stop—Session has ended.
- Accounting-On—Creation of a new RADIUS client.
- Accounting-Off—RADIUS client has shut down.

Each session might generate Start, Interim-Update, and Stop messages based on the local configuration when the session is initiated. Each Start message tells the RADIUS server that a session has started. Each Interim-Update message changes the session parameters, and may report the session characteristics for the session to that point. Each Stop message informs the RADIUS server that a session has ended and reports session characteristics.

The RAS has the ability to transmit all RADIUS messages related to a session at the end of the session, regardless of which messages are generated and when they are generated. Some customers might choose this option to reduce the likelihood of the RADIUS messages being logged to different servers, or in different log files on the same server.

The RAS always generates a RADIUS Stop message when the session ends, regardless of the session termination cause. The termination cause and the session characteristics are reported.

### RADIUS Messages

The following table identifies the relationship between the signaling elements and the RADIUS attributes included in Accounting Request messages to the RADIUS server.

RADIUS Attribute	Data Element	Message
NAS IP-Address	IP address of the SIP proxy or the H.323 stack's call signal address.	Start, Interim-Update, Stop, On, Off
NAS Port	SIP proxy port or the H.323 stack's call signaling RAS port.	Start, Interim-Update, Stop, On, Off
NAS Identifier	<p>Value, if any, set in the optional NAS-ID field for the accounting server that you configure as part of the accounting configuration. This identifier sets the value that the remote server (the accounting server) uses to identify the SBC so that RADIUS messages can be transmitted.</p> <p>The remote server to which the accounting configuration will send messages uses at least one of two pieces of information for identification:</p> <p>NAS IP address: always included in the accounting message</p> <p>NAS identifier: configured in the NAS-ID parameter of the accounting server; if configured, the NAS identifier is sent to the remote server</p> <p>This attribute only appears if a value is configured in the NAS-ID field.</p>	Start, Interim-Update, Stop, On, Off
Acct-Session-ID	Either the Call-ID field value of the SIP INVITE message, the callIdentifier of the H.323 message, or RADIUS client information.	Start, Interim-Update, Stop, On, Off
Called Station ID	To field value of the SIP INVITE message (a type of message used to initiate a session) or the calledPartyNumber of the H.323 message.	Start, Interim-Update, Stop
Calling Station ID	From field value of the SIP INVITE message or the callingPartyNumber of the H.323 message.	Start, Interim-Update, Stop
Acct-Terminate-Cause	Reason for session ending (refer to <a href="#">Session Termination</a> session).	Stop, Off
Acct-Session-Time	Length of session (time in seconds, or milliseconds if so configured).	Interim-Update, Stop, Off

## Session Termination

Sessions are terminated for reasons that include normal termination, signaling failure, timeout, or network problems. The following table maps RADIUS accounting termination cause codes to network events.

RADIUS Termination Cause	Event	Message
User request	SIP BYE message or H.323	Stop
User error	SIP signaling failed to establish session (accompanied by disconnect cause)	Stop

RADIUS Termination Cause	Event	Message
NAS request	RADIUS server disabled	Off

## Interim RADIUS Records for Recursive Attempts

When the SBC routes calls, it performs local policy look-ups that can return several next hops, ordered by preference. This can also happen as a result of an LRT lookup, an ENUM query response, or SIP redirect. To set up sessions, the SBC uses—in ordered preference—and recurses through the list if it encounters failures.

You can configure SIP accounting to send RADIUS Interim records when the SBC encounters these failures. The interim message contains: the destination IP address, the disconnect reason, a timestamp for the failure, and the number that was called. This feature is enabled by setting the `generate-interim` parameter to **unsuccessful-attempt**. Please refer to Appendix B to view the format of an unsuccessful-attempt interim record.

## SIP CDR Stop Time

You can set up your global SIP configuration so the disconnect time reflected in a RADIUS CDR is the time when the SBC receives a BYE. Enabling this parameter also means the disconnect time is defined when the SBC sends a BYE to the UAS and UAC. Otherwise, the CDR's value is based on when the 200 OK confirms the BYE.

The applicable RADIUS CDR in this case is the standard RADIUS attribute `Acct-Session-Time`, number 46.

## ACLI Instructions and Examples

To enable definition of the disconnect time based on the BYE:

1. Access the **sip-config** configuration element.

```
ORACLE# configure terminal
ORACLE(configure)# session-router
ORACLE(session-router)# sip-config
ORACLE(sip-config)#
```

2. Select the **sip-config** object to edit.

```
ORACLE(sip-config)# select
```

```
ORACLE(sip-config)#
```

3. **set-disconnect-time-on-bye**—Set this parameter to **enabled** if you want to use the BYE message as the defining factor for the disconnect time. This parameter is disabled by **default**.
4. Type **done** to save your configuration.

## Media Stop Time VSA in CDRs

An accurate portrayal of a call's media stop time is important for billing accuracy. Calls are often terminated well after the media has stopped flowing for such reasons as network or equipment peculiarities.

## Media Stop Time VSAs

To record the actual media stop time, the Oracle Communications Session Border Controller writes the following four VSAs in CDR Stop Records:

```
Acme-Flow-Calling-Media-Stop-Time_FS1
Acme-Flow-Called-Media-Stop-Time_FS1
Acme-Flow-Calling-Media-Stop-Time_FS2
Acme-Flow-Called-Media-Stop-Time_FS2
```

These VSAs correspond to:

- calling side's media stop time - stream 1
- called side's media stop time - stream 1
- calling side's media stop time - stream 2
- called side's media stop time - stream 2

## Media Stop Time Calculation

The granularity of the time at which the Oracle Communications Session Border Controller's checks for media stream idleness, the actual media stop time, as inserted into a CDR is accurate to between 0 and +10 seconds.

In the following diagram, media idleness monitoring is checked in 10 second time frames. Labeled time measurements are as follows:

- $T_c$ —Time between most recent idleness sample end and end-of-call time
- $T_m$ —2 complete idleness windows
- $T_e$ —Time into the idleness window in which the call's media stopped. This is also the error amount of the recorded media stop time
- $T_i$ —The actual time between the end of media and the end of call

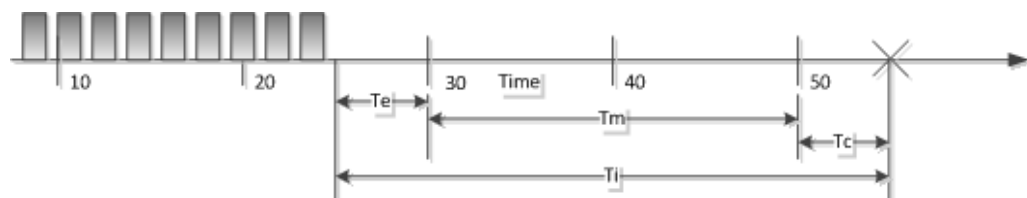

$T_m$  and  $T_c$  are known. The Oracle Communications Session Border Controller also knows that the media ended between 20 and 30 seconds, but the actual time,  $10 - T_e$  into the frame is unknown. Thus, the time recorded in the CDR is quantized up to the end of the media stop frame at 30 seconds. This time, as written to the CDR, must be interpreted with possible error of  $0 \leq T_e < 10$  seconds.

### Media Stop Time during HA Switchover

When a switchover occurs between media stop time and end of call, the media stop time written to the CDR is the failover time.

## Millisecond Granularity for CDRs

Some accounting features require greater precision. The attribute **acct-session-time** can be configured to be in milliseconds.

The RADIUS attribute **acct-session-time** uses seconds as its default. You can set this to a millisecond granularity in the **account-config** configuration element using the option **millisecond-duration**. This option setting is required for the RADIUS CDR display, Diameter RF accounting and locally-generated CDR comma separated value (CSV) files behaviors.



#### Note:

Changing to millisecond granularity violates RFC 2866.

## Configure acct-session-time for millisecond granularity

Set the option for millisecond granularity for the **acct-session-time** attribute.

1. Access the **account-config** configuration element.

```
ORACLE# configure terminal
ORACLE(configure)# session-router
ORACLE(session-router)# account-config
ORACLE(account-config)#
```

2. Type **select** to begin configuring this object.
3. **options**—Set the **options** parameter by typing **+options**, a Space, the option name **millisecond-duration** and then press Enter.
4. Type **done** to save your configuration.

## SIP Call Tear Down Due to Media Guard Timer Expiration

When a SIP call is torn down by the SBC due to media timers expiring, the following standard and VSA attributes and their corresponding values will appear in the CDR stop message together:

**Table 2-1 Media Guard Timer Expiration in CDR**

CDR Attribute	Value	Explanation
Acct-Terminate-Cause	Idle-Timeout	This standard RADIUS AVP indicates the call was ended due to a timer expiring.
h323-disconnect-cause	"6"	This VSA AVP indicates the call was ended due to a timeout.

Table 2-1 (Cont.) Media Guard Timer Expiration in CDR

CDR Attribute	Value	Explanation
Acme-Disconnect-Initiator	3	This VSA AVP indicates the call disconnect was initiated internally from the SBC, and not from an endpoint or due to an unknown reason.

## Set Accounting Message Generation

You set the account configuration parameters to define high level accounting information. After setting initial parameters in the account-config, you must create one or more accounting-servers that define the systems where RADIUS accounting CDRs are sent.

To configure the account configuration:

1. Access the **account-config** configuration element.

```
ORACLE# configure terminal
ORACLE(configure)# session-router
ORACLE(session-router)# account-config
ORACLE(account-config)#
```

2. **generate-start**—Retain the default value **ok** if you want the RADIUS Start message to be generated once the SBC receives an OK message in response to an INVITE.

Other options include:

- Invite—RADIUS Start message should be generated once the SBC receives a SIP session INVITE.
- None—RADIUS Start message is not generated.
- ""—When two quotation marks are entered next to each other (empty), behavior is identical to none value.

3. **generate-interim**—Retain the default value **reinvite response** to cause the SBC to transmit a RADIUS Interim message. (A RADIUS Interim message indicates to the accounting server that the SIP session parameters have changed.)

You can select none, one, or more than one of the following values:

- ok—RADIUS Start message is generated when the SBC receives an OK message in response to an INVITE.
- reinvite—RADIUS Interim message is generated when the SBC receives a SIP session reINVITE message.
- reinvite response (default)—RADIUS Interim message is generated when the SBC receives a SIP session reINVITE and responds to it (for example, session connection or failure).
- reinvite cancel—RADIUS Interim message is generated when the SBC receives a SIP session reINVITE, and the Reinvite is cancelled before the SBC responds to it.



- unsuccessful-attempt—RADIUS Interim message is generated when a SIP session set-up attempt from a preference-ordered list of next-hop destinations is unsuccessful. This can happen when a local policy lookup, LRT lookup, ENUM query response, or SIP redirect returns a preference-ordered list of next-hop destinations. The interim message contains: the destination IP address, the disconnect reason, a timestamp for the failure, and the number that was called.
4. **intermediate-period**—Set the time in seconds between generating periodic interim records. This parameter defaults to zero, which is not a valid value.  
Interim record generation for each call type is as follows:
    - H.323—The periodic timer (set to the value you specify in the accounting configuration) is dynamically created when the SBC receives a Connect message and an H.323 call answer method is invoked. The SBC deletes the timer when the H.323 session is terminated.
    - SIP—The periodic timer (set to the value you specify in the accounting configuration) is dynamically created when the SBC receives an initial INVITE message. The SBC deletes the timer when the session is terminated.
  5. Type **done** to save your configuration.

## Enhanced Stop CDR Reporting for Exceeded Ingress Session Constraints

The SIP **enhanced-cdr** option enables consistent generation of RADIUS Stop records on both ingress and egress paths. With **enhanced-cdr** enabled, RADIUS Stop records are generated in response to any ingress path rejection of a dialog creating SIP INVITE request. The contents of RADIUS Stop records are also written to the local CDR files (if enabled).

Use the following command syntax to enable consistent generation of RADIUS Stop records.

```
ORACLE(sip-config) # options +enhanced-cdr
ORACLE(sip-config) #
```

In legacy releases there was an inconsistency in the generation of RADIUS Stop records when calls are rejected for exceeding configured session ingress or egress constraints. On the egress path, legacy releases rejected such calls with a 503 (Service Unavailable) response and the generation of a RADIUS STOP record. On the ingress path, however, while calls were rejected with a 503 response, RADIUS Stop records were not generated.

## Including P-Visited Network Identifier and History-Info Headers in CDRs

You can configure the SBC to add fully compliant P-Visited Network Identifier (PVNI) and History-Info (HI) headers in CDRs. You configure this by adding the **pcscf-cdr-compliance** option to the **account-config**, specifying whether you want to include PVNI (**PVNI-pref**), HI (**HI-pref**), or both. The behavior is dependent on the type of call, including Mobile Terminating (MT) and Mobile Originating (MO), information provided by SIP, and whether you are also using an S8HR profile.

The PVNI and HI fields in CDRs may or may not contain data. When configured, the SBC performs processes to determine whether or not to add:

- P-Visited-Network-ID to the applicable CDR field
- History-Info to the applicable CDR field

You configure the **pcscf-cdr-compliance** in the applicable **account-config** to use these processes within your environment.

```
ORACLE# configure terminal
ORACLE (configure) # session-router
ORACLE (session-router) # account-config
ORACLE (account-config) # select
ORACLE (account-config) # options +pcscf-cdr-compliance=PVNI-pref
```

If you save and activate this configuration, the SBC enables PVNI CDR population for MT calls. To configure for both PVNI and HI headers, configure the option with both values separated by a comma and enclosed in quotes.

```
ORACLE (account-config) # options +pcscf-cdr-compliance="PVNI-pref,HI-pref"
```

### Support for P-Visited-Network-ID Field

For MT calls, the access SBC, deployed as an A-SBC, inserts the PVNI header in CDRs based on the called party registration cache entry (MCC/MNC). If the Called party registration cache does not have a PVNI value, the A-SBC inserts the **network-id** value from the access side (egress realm) **sip-interface** configuration as the PVNI into CDRs.

For both MO and MT and when you configure it to add PVNI to CDRs, the A-SBC checks for an **s8hr-profile** in the same interface:

- If there is an S8HR profile on the access **sip-interface**:
  - If the SBC receives an MCC/MNC from the Rx server, it creates the PVNI header using the called party registration cache entry (MCC/MNC) and adds it to the CDR.
  - If the SBC does not receive an MCC/MNC, It checks whether there is a **network-id** value on the access side **sip-interface**:
    1. If so, the SBC creates the PVNI using that **network-id** value.
    2. If not, the SBC uses the **local-mccmnc** value as the PVNI, and adds it to CDR.

#### Note:

If you have not configured the **local-mccmnc** value in your S8HR profile, the SBC uses the default, which is 999999.

- If there is not an S8HR profile on the access **sip-interface**, the SBC checks whether there is a **network-id** value on the access side **sip-interface**. If so, the SBC uses the **network-id** value as the PVNI, and adds it to CDR.
- If both the S8HR and the egress (access) **network-id** are not configured, the SBC checks whether the initial INVITE/MESSAGE comes from a trusted endpoint and contains a PVNI:
  - If so, the SBC relays the PVNI and add to CDR.
  - If not, the SBC leaves the PVNI field empty.

When you have set the **pcscf-cdr-compliance** option to include PVNI, and the SBC is acting as an I-SBC handling MO/MT calls, the SBC uses the following sequence for populating the CDR field:

1. If configured, uses the **network-id** on the ingress **sip-interface** as PVNI.
2. If populated and from a trusted endpoint, uses the PVNI from the initial INVITE.
3. Leaves the PVNI field empty.



#### Note:

This behavior applies to the INVITE or any Re-INVITE.

### Support for History-Info Field

For MO calls, if you have configured the HI option in the **account-config**, SBC uses the History-Info(s) received in the initial INVITE replies, including those with 181, 180 or 200 status-codes. The SBC populates the CDR with the last provisional (>100) or final (200) response containing History-Info(s). If History-Info is not available in provisional or final replies, the SBC leaves the History-Info in the CDR empty.

For MT calls, SBC extracts History-Info header(s) from the initial INVITE and adds them to the CDR. If History-Info is not available in the initial INVITE, the SBC leaves the HI field empty.

If there are multiple History-Info headers in the initial INVITE, the SBC concatenates all the history-info headers values, and without exceeding the default or configured CDR field size, adds them to the CDR.

For example, assume INVITE has three History-Info headers in the following order:

1. HI-1 - 100 characters
2. HI-2 - 100 characters
3. HI-3 - 100 characters

By default, the maximum CDR field size is 246. In this case, the SBC includes the first two History-Info headers in their entirety, and truncates HI-3.

Consider the presence of the following HI headers:

- History-Info: <sip:bob@example.com>;index=1
- History-Info: <sip:office@example.com>;index=1.2;mp=1
- History-Info: <sip:office@192.0.2.5>;index=1.2.1;rc=1.2

The SBC populates the History-Info CDR as follows

```
<sip:bob@example.com>;index=1, <sip:office@example.com>;index=1.2;mp=1,
<sip:office@192.0.2.5>;index= 1.2.1;rc=1.2
```

## Including the Reason-Header AVP in CDRs

You can configure the SBC to include reason header AVPs in diameter STOP and EVENT CDRs within the context of a configured **account-config**. When configured, the SBC does this for both cause information it receives from another device and for cause information the

system generates itself. To do this, you enable the **add-reason-header** parameter in the **sip-config**. When enabled, the SBC includes the Reason-Header AVP in Diameter Accounting Request (ACRs) for Accounting-Record-Type [STOP/EVENT] CDRs per spec 3GPP TS 32.299 V13.5.0 for both in-dialog and out-of-dialog messages. This is in addition to the parameter's other functions, including adding the SIP reason header to BYE, CANCEL, and SIP Error Responses (4xx, 5xx, 6xx). You can customize the text used in reason headers using the **local-error** parameters in the **local-response-map** that you apply to your target traffic.

The system checks incoming BYE, CANCEL, and SIP Error Responses (4xx, 5xx, 6xx) for reason headers to propagate using either default or customized messaging you have specified in your local response map. These headers would be presented as Q.850 cause and text information. If the incoming message does not include reason headers, the SBC does not insert a reason header AVP in the ACR or a reason header in the ensuing signaling. If it receives multiple reason-headers, the system adds them all in both AVP and the signaling. If the SBC does not have a customized or default mapping for a SIP error code, it maps that code to the q850CauseTypeInternalError (47).

In addition to reason header propagation, the SBC generates reason headers based on issues it identifies itself. These would usually be 6xx responses. For these situations, the SBC also includes the reason-header AVP for CDRs and SIP error messages for egress. The system uses the default or customized messaging configured in the **local-response-map** for its own reason headers.

 **Note:**

The SBC never uses SIP cause and text to construct its own reason headers. Instead, it adds the q850 cause and text. It does, however, make the content of Reason-Header AVP the same as that of received SIP Reason: header.

To create reason headers, the SBC concatenates the q.850-cause and q.850-reason. A formatted example of a SIP reason-header follows.

```
Q.850;cause=16;text="Call Terminated"
```

See [Configure Reason and Cause Mapping for SIP-SIP Calls](#) for instructions on configuring a **local-response-map**, including the **local-error** parameters and the **add-reason-header** parameter.

### Default Reason Header Information

When you enable the **add-reason-header** in the **sip-config** without having configured a **local-response-map**, the SBC adds reason information to responses and CDRs using default q.850 reason-text and q.850 cause-codes. An example of default text for the 488 message code is "Not Acceptable here". The SBC includes all error code enumerations in the local-error listing within the **local-response-map**. Default values are presented below.

SIP Error Codes	Integer Value	Q850 Cause Codes	Integer Value
RESP_STATUS_MOVE D	301	q850CauseTypeNumber Changed	22
RESP_STATUS_BAD	400	q850CauseTypeInternal Error	47
RESP_STATUS_UNAUT H	401	q850CauseTypeIncomin gBarred	55
RESP_STATUS_PAY_R EQ	402	q850CauseTypeIncomin gBarred	55
RESP_STATUS_FORBI DDEN	403	q850CauseTypeIncomin gBarred	55
RESP_STATUS_NOT_F OUND	404	q850CauseTypeDestUnr eachable	3
RESP_STATUS_NOT_A LLOW	405	q850CauseTypeIncomin gBarred	55
RESP_STATUS_NOT_A CCEPT	406	q850CauseTypeIncomin gBarred	55
RESP_STATUS_AUTH_ REQ	407	q850CauseTypeIncomin gBarred	55
RESP_STATUS_REQ_T MO	408	q850CauseTypeNoUser Responding	18
RESP_STATUS_CONFL ICT	409	q850CauseTypeInternal Error	47
RESP_STATUS_GONE	410	q850CauseTypeNumber Changed	22
RESP_STATUS_LEN_R EQ	411	q850CauseTypeInternal Error	47
RESP_STATUS_TOO_B IG	413	q850CauseTypeInvalidM essageRecv	95
RESP_STATUS_URI_T OO_BIG	414	q850CauseTypeInvalidM essageRecv	95
RESP_STATUS_MEDIA	415	q850CauseTypeMediaN egFailure	65
RESP_STATUS_BAD_E XT	420	q850CauseTypeInvalidM essageRecv	95
RESP_STATUS_TMP_U NAVAIL	480	q850CauseTypeNouser Answer	19
RESP_STATUS_NO_EX IST	481	q850CauseTypeInternal Error	47
RESP_STATUS_LOOP	482	q850CauseTypeInternal Error	47
RESP_STATUS_TOOM NY_HOPS	483	q850CauseTypeExchan geRoutingError	25
RESP_STATUS_ADDR_ INCMPPL	484	q850CauseTypeInvalidN umberFormat	28
RESP_STATUS_ambiguous	485	q850CauseTypeInternal Error	47
RESP_STATUS_BUSY_ HERE	486	q850CauseTypeUserBu sy	17
RESP_STATUS_CANC ELLED	487	q850CauseTypeInternal Error	47

SIP Error Codes	Integer Value	Q850 Cause Codes	Integer Value
RESP_STATUS_NOT_H ERE	488	q850CauseTypeMediaN egFailure	65
RESP_STATUS_INT_E RR	500	q850CauseTypeInternal Error	47
RESP_STATUS_NOT_I MPL	501	q850CauseTypeFacility Rejected	29
RESP_STATUS_BAD_G TWY	502	q850CauseTypeDestOut ofOrder	27
RESP_STATUS_SVC_U NAVAIL	503	q850CauseTypeInternal Error	47
RESP_STATUS_GTWY _TMO	504	q850CauseTypeTimeout	102
RESP_STATUS_BAD_V ER	505	q850CauseTypeInvalidM essageRecv	95
RESP_STATUS_BUSY	600	q850CauseTypeUserBu sy	17
RESP_STATUS_DECLI NE	603	q850CauseTypeCallRej ected	21
RESP_STATUS_DONT_ EXIST	604	q850CauseTypeDestUnr eachable	3
RESP_STATUS_NOTAC CEPT	606	q850CauseTypeInternal Error	47

### Changing Default Reason Text

You configure the Q850 cause code using the **entries** configuration in the **local-response-map** table for SIP Error Codes. You configure Q850 cause codes corresponding to each local error one at a time. The example configuration below sets the Q850 cause code and reason text corresponding to the locally generated SIP error 488.

```
ORACLE# sh running-config local-response-map
local-response-map
entries
local-error      not-acceptable-here-488
sip-status       488
q850-cause       65
sip-reason
q850-reason      Not Acceptable Here
```

Assume the SBC generates a 488. Using the **entries** configuration above, to specify the Q850 cause code. The SBC would construct the SIP Reason Header using the q850-cause and q850-reason.

The resulting message would be:

```
Reason: Q.850;cause=65;text="Not Acceptable Here"
```

Similarly, for 5xx, 6xx as per the Q850 cause code and reason text configured in local-response-map, SBC constructs the reason header using these values.

```
ORACLE# sh running-config local-response-map
local-response-map
entries
local-error      sip-locally-generated-by
sip-status
q850-cause      16
sip-reason
q850-reason      Bye Call Terminated
```

The resulting message would be:

```
Reason: Q.850;cause=16;text="Bye Call Terminated"
```

If you do not configure the message, the default resulting message would be:

```
Reason: Q.850;cause=16;text="Call Terminated"
```

## Configure the System to Add Reason Headers

To enable the SBC to add the Reason header:

1. In Superuser mode, type `configure terminal` and press Enter.

```
ORACLE# configure terminal
```

2. Type `session-router` and press Enter.

```
ORACLE (configure)# session-router
```

3. Type `sip-config` and press Enter.

```
ORACLE (session-router)# sip-config
ORACLE (sip-config)#
```

4. `add-reason-header`—Enable this parameter to add the Reason header(s) to responses and CDRs.

The default value is disabled. The valid values are:

- enabled | disabled

5. Save and activate your configuration for changes to take effect.

## Per Realm Accounting Control

You can enable or disable accounting control for specific ingress realms using the **accounting-enable** parameter. This parameter is enabled by default.

The SBC's SIP and H.323 tasks check whether this parameter is set to enabled or disabled, and sends records on that basis.

 **Note:**

This realm configuration does not trigger accounting of MESSAGE and REGISTER traffic.

### Egress Realm Accounting Option

You can also set the **force-realm-accounting** option in the **sip-config** to ensure the SBC performs accounting based on this configuration on the egress realm.

For session accounting, the SBC checks the realm accounting configuration on both the ingress and egress realms. If the accounting configuration is enabled on either realm, and you have enabled the **sip-config** option, the SBC performs accounting for that session. If you have not enabled the **sip-config** option, the SBC only performs accounting for calls at the ingress realms that have accounting enabled.

This option also causes the SBC to perform accounting for REGISTER and MESSAGE requests. For this purpose, the SBC first checks whether you have configured the **sip-config** option. If set, the SBC checks the realm accounting configuration on the ingress and egress realms. If you have configured realm accounting configuration on either realm, the SBC performs accounting on these messages.

The syntax for this option follows.

```
ORACLE(sip-config)# options + force-realm-accounting
```

Both the **force-realm-accounting** option and the **accounting-enable** parameter are RTC supported.

## ACLI Instructions

To configure per realm accounting:

1. Access the **realm-config** configuration element.

```
ORACLE# configure terminal
ORACLE(configure)# media-manager
ORACLE(media-manager)# realm-config
ORACLE(realm-config)#
```

2. Select the **realm-config** object to edit.

```
ORACLE(realm-config)# select
identifier:
1: realm01 left-left:0 0.0.0.0

selection: 1
ORACLE(realm-config)#
```

3. **accounting-enable**—Either leave this parameter set to enabled (default) to generate CDRs for this realm, or change it to disabled.
4. Type **done** to save your configuration.



## RADIUS CDR Content Control

CDRs can be customized to limit their size as generated. The SBC's RADIUS accounting provides a detailed set of records that can contain, for example, multiple media flow descriptions for forked calls that can contain multiple sets of media and QoS attributes. While the level of detail might be required for some networks, in others the large CDRs generated to reflect that level of granularity can cause issues for the application receiving the records.

You can control the size of the RADIUS CDRs your SBC produces:

- Duplicate RADIUS attribute prevention—Using this feature, you can configure the SBC to send only one set of RADIUS attributes in CDR for a forked call. (When a forked SIP INVITE contains media information, media and QoS attributes can potentially be duplicated.)
- RADIUS attribute selection—You can set a list of the Oracle VSAs you want included in a RADIUS CDR, and the SBC will exclude the others from the record; standard attributes are always included. You specify attributes using their unique identifier in a comma-delimited list, and you can list them in any order. However, entering an invalid range disables this feature.  
The SBC excludes attributes from the records in which they are already defined. If an attribute only appears in a Stop record, then it will be deleted from Stop records.

### Configuring Duplicate RADIUS Attribute Generation

To enable duplicate RADIUS attribute prevention:

1. Access the **account-config** configuration element.

```
ORACLE# configure terminal
ORACLE(configure)# session-router
ORACLE(session-router)# account-config
ORACLE(account-config)#
```

2. Type **select** to begin configuring this object.
3. **prevent-duplicate-attrs**—Enable this parameter to prevent the SBC from duplicating attributes in the accounting records it generates. This duplication can be caused, for example, by multiple media sessions within the context of a call. Retaining the default (disabled) allows the SBC to include duplicate attributes in RADIUS, Diameter and Local accounting records. This can result in attribute placement and counts that are less consistent.
4. Save and activate your configuration.

### Configuring Specific RADIUS Attributes for CDR Inclusion

You enter the list of VSAs that you want included as a comma-delimited list. There are special entry types you can use in the comma-delimited list to set ranges and make entries easier:

- X- — Where X is a VSA identifier, the SBC will include all attributes with an identifier equal to or greater than X.
- -X — Where X is a VSA identifier, the SBC will include all attributes with an identifier equal to or less than X.

- - — Use the minus sign (-) alone when you want to turn off attribute selection, including all VSAs in the CDR.

To enter a list of RADIUS attributes to include in a CDR:

1. Access the **account-config** configuration element.

```
ORACLE# configure terminal
ORACLE(configure)# session-router
ORACLE(session-router)# account-config
ORACLE(account-config)#
```

2. Type **select** to begin configuring this object.
3. **vsa-id-range**—Enter a comma-delimited list that represents the VSA you want to appear in the RADIUS CDR. There is no default for this parameter.

Do not use <Spaces> when typing in your comma-delimited list.

```
ORACLE(account-config)# vsa-id-range -5,7,10-
```

This entry specifies that CDRs contain VSA with identifiers equal to and less than 5, VSA 7, and VSAs with identifiers equal to and greater than 10.

Limit this list to accounting VSAs. For example, VSA 254 is an authentication VSA, so it should not be included in the range. The system generates validate-config errors if your range includes VSAs that are not accounting VSAs.

4. Save and activate your configuration.

## Custom RADIUS CDR VSAs for SIP

This section describes these additions to the SBC's RADIUS accounting capabilities for customizing your call detail records (CDRs):

- Generating CDRs with call detail information from a SIP message—The SBC reserves a set of vender-specific attributes (VSAs) and then populates them according to your header manipulation (HMR) configuration
- Generating CDRs with trunk group information—You can enable your SBC to provide terminating trunk-group and trunk-context data even when the SBC is not performing trunk-group routing.

Both support using the CSV file for RADIUS records, which you can either save locally or push to a defined FTP server.

## About User-Defined VSAs for SIP Calls

The SBC reserves VSAs 200-229 for you to define for use with SIP calls. These VSAs should never be used for other purposes, and their use should never conflict with the need to add new VSAs in the future. Because this leaves a significant number of VSAs unused, there is still ample space for any new VSAs that might be required.

Since RADIUS START records are created on session initiation, their content cannot be updated. However, the content for INTERIM and STOP records can be.

To configure user-defined VSAs for a SIP call, you use HMR. For example, when you set up HMR correctly, the SBC reports originating or terminating country codes in

CDRs in whatever format they appear in the SIP username field. The HMR rules you configure uses the SIP header name P-Acme-VSA, adding it to the SIP header from any part of the SIP message. Then the SBC searches for the P-Acme-VSA header, generates a VSA for it, and then includes that VSA in the CDR for the call.

You can include multiple custom VSAs per CDR by adding the corresponding number of rules; in essence, you add in the header as many times as required.

## HMR Adaptations

The following HMR element rule types support user-defined VSA for SIP calls:

- **uri-user-only**—The **uri-user-only** element rule type represents the URI username without the URI user parameters. You can perform these actions for the **uri-user-only** type: store, replaces, delete, and add. This means, for example, that you can add a username string to SIP or TEL URI without having any impact on other parameters.
- **uri-phone-number-only**—The **uri-phone-number-only** applies when all rules are met. It refers to the user part of the SIP/TEL URI without the user parameters when the user qualifies for the BNF shown here:

```
uri-phone-number-only = [+]1*(phone-digit / dtmf-digit / pause-
character)
phone-digit           = DIGIT / visual-separator
DIGIT                 = "0" / "1" / "2" / "3" / "4" / "5" / "6" /
"7" / "8" / "9"
visual-separator      = "-" / "." / "(" / ")"
dtmf-digit            = "*" / "#" / "A" / "B" / "C" / "D"
pause-character       = "p" / "w"
```

Once the URI user part qualifies as a **uri-phone-number-only** based on this BNF, the SBC ignores the visual separators when comparing it against a match value. Furthermore, the SBC performs on or using the **uri-phone-number-only** after the excluding the visual separators.

But anew value being added as a **uri-phone-number-only** or replacing a **uri-phone-number-only** does not have to match the BNF noted above. That is, you can use the **uri-phone-number-only** type knowing that:

- The action only occurs if the URI username matches the BNF defined here.
- Even so, you can also replace the **uri-phone-number-only** with one that does not match—using the same rule.

## HMR String Variable

HMR supports the use of a string variable that you can use to populate headers and elements. You set this value in the **manipulation-string** parameter for a realm, SIP session agent, or SIP interface. Then, you reference it as the \$MANIP\_STRING variable.

When a message arrives, the SBC matches the string you provision to the closest session agent, realm, or SIP interface. The precedence for matching is in this order: session agent, realm, and then SIP interface. For example, the SBC populates messages matching a session agent using the \$MANIP\_STRING variable, but it leaves the value empty for session agents that do not match.

You can use the string variable, for instance, for values specific to realms and session agents such as country code values when the regular expression pattern used to match a country code fails to do so.

## Configure User-Defined VSAs

This section shows you how to configure user-defined VSAs for SIP calls. It also contains subsections with configuration examples so you can see how this feature is put to use.

This section also shows you two configuration examples for this feature.

To create a header manipulation rule that generates user-defined VSAs for SIP calls:

1. Access the **sip-header-rules** configuration element.

```
ORACLE# configure terminal
ORACLE(configure)# session-router
ORACLE(session-router)# sip-manipulation
ORACLE(sip-manipulation)# header-rules
ORACLE(sip-header-rules)#
```

2. **name**—Enter a meaningful name for the header rule you are creating. For example, if you want to add VSA 200 to your CDRs for SIP calls, you might name your rule **generateVSA200**. There is no default for this parameter, and it is required.
3. **header-name**—Set this parameter to P-Acme-VSA so the SBC will add this accounting information to CDRs for the call.
4. **action**—Set this parameter to **add**.
5. **new-value**—Enter the regular expression value for the new value you want to add. For example, to add VSA 200 that contains the value from the SIP From header, you would enter **200:+\$storeFrom.\$0**.
6. Save and activate your configuration.

The first example shows you how to generate custom VSA for the To and From headers in SIP messages.

- VSA 200 contains the header value from the SIP From header.
- VSA 220 contains the header value from the SIP To header.

```
sip-manipulation
  namecustom                                VSA1
  description
  header-rule
    name                                     storeFrom
    header-name                             from
    action                                   store
    comparison-type                         pattern-rule
    match-value                             .*
    msg-type                                request
    new-value
    methods                                 INVITE
  header-rule
    name                                     storeTo
```

```

        header-name      to
        action            store
        comparison-type  pattern-rule
        match-value      .*
        msg-type          request
        new-value
        methods           INVITE
    header-rule
        name              generateVSA200
        header-name      P-Acme-VSA
        action            add
        comparison-type  case-sensitive
        match-value
    msg-type              any
        new-value        200:+$storeFrom.$0
        methods           INVITE
    header-rule
        name              generateVSA220
        header-name      P-Acme-VSA
        action            add
        comparison-type  case-sensitive
        match-value
        msg-type          any
        new-value        220:+$storeTo.$0
        methods           INVITE
  
```

The second example shows you how to configure HMR to generate VSA 225, which contains the customer P\_From header when it is present. When that header is not present, the rule instructs the SBC to include the header value from the SIP From header for VSA 225.

```

sip-manipulation
  name          customVSA1
  description
  header-rule
    name        storePfrom
    header-name P_From
    action      store
    comparison-type pattern-rule
    match-value .*
    msg-type    request
    new-value
    methods     INVITE
  header-rule
    name        storeFrom
    header-name from
    action      store
    comparison-type pattern-rule
    match-value .*
    msg-type    request
    new-value
  methods              INVITE
  header-rule
    name          generateVSA225_1
    header-name  P-Acme-VSA
    action      add
  
```

```

        comparison-type      case-sensitive
        match-value
        msg-type             request
        new-value            225:+$storeFrom.$0
        methods              INVITE
    header-rule
        name                  generateVSA225_2
        header-name           P-Acme-VSA
        action                 manipulate
        comparison-type       pattern-rule
        match-value           $storePfrom
        msg-type               request
        new-value
        methods                INVITE
    element-rule
        name                  one
        parameter-name
        type                   header-value
        action                  delete-element
        match-val-type         any
        comparison-type       pattern-rule
        match-value            ^225.*
        new-value
    element-rule
        name                  two
        parameter-name
        type                   header-value
        action                  add
        match-val-type         any
        comparison-type       case-sensitive
        match-value
        new-value
    225:+$storePfrom.$0
  
```

## ACLI Instructions String Variable

To use the HMR string variable, you set the **manipulation-string** value in the SIP session agent, realm, or SIP interface where you want the feature applied. The following sample shows you how to configure the **manipulation-string** parameter for SIP session agent.

1. Access the **session-agent** configuration element.

```

ORACLE# configure terminal
ORACLE(configure)# session-router
ORACLE(session-router)# session-agent
ORACLE(session-agent)
  
```

2. **manipulation-string**—Enter a value that references the \$MANIP\_STRING variable that will be used to populate SIP headers and elements using HMR. There is no default value for this parameter.
3. Save and activate your configuration.

## Trunk-Group VSA Generation

You can force the SBC to generate VSAs related to trunk groups even when you are not using the trunk group feature. With the **force-report-trunk-info** parameter turned on in the session router configuration:

- The SBC reports terminating trunk group and trunk-context information even though it has not perform trunk-group routing. The appropriate VSAs report the terminating trunk-group (VSA 65) and trunk context (VSA 67) with the information of the matching ingress session agent and realm of the originator.
- The SBC reports the terminating trunk-group (VSA 66) and trunk context (VSA 68) as the received trunk group and context from the call's SIP REQUEST message. If the SIP message has none, then the SBC uses the information from the matching egress session agent (or egress realm, when available) and next-hop realm. Note that information is reported after HMR processing—meaning that header manipulation has been performed on the message information reported.

## ACLI Instructions and Examples

You enable trunk-group VSA generation on a system-wide basis in the session-router configuration.

To enable forced trunk-group VSA generation:

1. In Superuser mode, type **configure terminal** and press Enter.

```
ORACLE# configure terminal  
ORACLE (configure) #
```

2. Type **session-router** and press Enter.

```
ORACLE (configure) # session-router  
ORACLE (session-router) #
```

3. Type **session-agent** and press Enter.

```
ORACLE (session-router) # session-router  
ORACLE (session-router) #
```

4. **forced-report-trunk-info**—Change this parameter to enabled if you want to turn on the SBC's ability to generate VSAs for trunk group information even when you are not using trunk-group routing. The SBC uses VSAs 65-68 to report originating and terminating trunk group information as described in the [Trunk-Group VSA Generation](#) section above. By default, this parameter is **disabled**.
5. Save and activate your configuration.

# 3

## RADIUS Accounting Management

This chapter provides information about management and monitoring of RADIUS accounting functions on your Oracle Communications Session Border Controller including.

- alarm generation and monitoring
- status and statistics monitoring

### Alarm Generation and Monitoring

The products generate alarms when certain hardware and software events occur. For more information about SBC alarms for RADIUS, refer to the Maintenance and Troubleshooting Guide.

The RADIUS ACCOUNTING CONNECTION DOWN alarm, detailed in the table below, is directly associated with the SBC's RADIUS functionality. When enabled connections to RADIUS servers have timed-out without a response from the RADIUS server, the alarm is activated. The RADIUS ACCOUNTING CONNECTION DOWN alarm triggers a Simple Network Management Protocol (SNMP) trap that is sent via the syslog Management Information Base (MIB) (ap-syslog.mib). For a list of all SNMP-related alarms and their associated traps, refer to the table of SNMP trap correlation to SBC's alarms in Oracle's MIB Reference Guide.

This alarm has no impact on a the health score of a SBC that is part of an HA Node.

### RADIUS Alarms

The table below describes the SBC's alarms for RADIUS.

Alarm	Alarm ID	Alarm Severity	Cause	Log Message	Actions
RADIUS ACCOUNTING CONNECTION DOWN	327681	CRITICAL if all enabled and configured RADIUS accounting server connections have timed-out without a response from the RADIUS server. MAJOR if some, but not all configured RADIUS accounting server connections have timed-out without a response from the RADIUS server.	The enabled connections to RADIUS servers have timed-out without a response from the RADIUS server.	CRITICAL: All enabled accounting connections have been lost. Check accounting status for more details. MAJOR: One or more enabled accounting connections have been lost. Check accounting status for more details.	apSyslogMessageGenerated trap generated critical, major dry contact syslog



## Status and Statistics Monitoring

The CLI **show radius** command, used with the three arguments described below, displays the status of any established RADIUS accounting connections and authentications. A working RADIUS connection displays READY, and a disabled connection displays DISABLED.

When an accounting server is disabled, the triggering and clearing of RADIUS ACCOUNTING CONNECTION DOWN alarms is not affected.

For more information about SBC about monitoring your SBC, refer to the Maintenance and Troubleshooting Guide.

### CLI Show RADIUS Display

The **show radius** command can take one of the three available arguments:

- authentication—Shows authentication statistics for primary and secondary RADIUS servers, including: server IP address and port; round trip time; information about failed and successful requests/authentications; number of rejections; number of challenges; number of time-outs, number of retransmissions
- accounting—Shows the information described in this table:
  - Client Display—General accounting setup (as established in the accounting configuration element), including information about the state of the RADIUS client, accounting strategy used (Hunt, Failover, RoundRobin, FastestRTT, or FewestPending), IP address and port on which the server is listening, maximum message delay in seconds, and number of configured accounting servers.
  - Waiting Queue—Amount of accounting (RADIUS) messages waiting to be sent. Waiting queue capacity is 4,096 messages.
  - <IP Address:Port>—Information about each configured accounting server (established in the accounting servers configuration). The heading above each accounting server section is the IPv4 address and port combination of the accounting server described. This section also includes information about the accounting server's state (e.g., Connect\_Attempt, INIT).
- all—Shows all of the information for both the authentication and accounting displays

The following is an example of the CLI **show radius authentication** command output.

```
ORACLE# show radius authentication
Active Primary Authentication Servers:
  server ipAddr: 172.30.0.7
Active Secondary Authentication Servers:
  server ipAddr: 172.30.0.8
Authentication Statistics:
  Server:"172.30.0.7:1812"
    RoundTripTime           :0
    MalformedAccessResponse:0
    AccessRequests          :2
    BadAuthenticators       :0
```

```

AccessRetransmissions :5
AccessAccepts         :0
Timeouts              :6
AccessRejects         :0
UnknownPDUTypes       :0
AccessChallenges      :0
Server:"172.30.0.8:1812"
RoundTripTime         :0
MalformedAccessResponse:0
AccessRequests        :2
BadAuthenticators     :0
AccessRetransmissions :9
AccessAccepts         :0
Timeouts              :10
AccessRejects         :0
UnknownPDUTypes       :0
AccessChallenges      :0

```

The following is an example of the ACLI **show radius accounting** command output.

**ORACLE# show radius accounting**

```

*****Client Display Start*****
Client State = READY, strategy=Hunt
listening on 127.0.0.1:1813
max message delay = 60 s, # of servers = 2
===== Waiting Queue =====
Waiting size = 89
=====
----- 10.0.0.189:1813 -----
Remote = 10.0.0.189:1813, Local = 0.0.0.0:1026, sock=45 (BOUND)
conn state=READY, RTT=250 ms
Min Rtt=250 ms, Max inactivity=60 s, expires at Nov 21 13:50:19.582, Restart
delay=30 s
----- 192.168.200.70:5050 -----
Remote = 192.168.200.70:5050, Local = 0.0.0.0:1027, sock=46 (BOUND)
conn state=DISABLED, RTT=0 ms
Min Rtt=250 ms, Max inactivity=60 s, expires at Nov 21 13:50:19.569, Restart
delay=30 s
*****Client Display End*****

```

The following is an example of the ACLI **show radius all** command output.

```

ORACLE# show radius all
*****Client Display Start*****
Client State = READY, strategy=Hunt
listening on 127.0.0.1:1813
max message delay = 60 s, # of servers = 2
===== Waiting Queue =====
Waiting size = 89
=====
----- 10.0.0.189:1813 -----
Remote = 10.0.0.189:1813, Local = 0.0.0.0:1026, sock=45 (BOUND)
conn state=READY, RTT=250 ms

```

```
Min Rtt=250 ms, Max inactivity=60 s, expires at Nov 21 13:50:19.582,
Restart delay=30 s
----- 192.168.200.70:5050 -----
Remote = 192.168.200.70:5050, Local = 0.0.0.0:1027, sock=46 (BOUND)
conn state=DISABLED, RTT=0 ms
Min Rtt=250 ms, Max inactivity=60 s, expires at Nov 21 13:50:19.569,
Restart delay=30 s
*****Client Display End*****
Active Primary Authentication Servers:
  server ipAddr: 172.30.0.7
Active Secondary Authentication Servers:
  server ipAddr: 172.30.0.8
Authentication Statistics:
  Server:"172.30.0.7:1812"
    RoundTripTime           :0
    MalformedAccessResponse:0
    AccessRequests          :2
    BadAuthenticators       :0
    AccessRetransmissions   :5
    AccessAccepts           :0
    Timeouts                 :6
    AccessRejects           :0
    UnknownPDUTypes         :0
AccessChallenges           :0
  Server:"172.30.0.8:1812"
    RoundTripTime           :0
    MalformedAccessResponse:0
    AccessRequests          :2
    BadAuthenticators       :0
    AccessRetransmissions   :9
    AccessAccepts           :0
    Timeouts                 :10
    AccessRejects           :0
    UnknownPDUTypes         :0
    AccessChallenges        :0
```

# 4

## Local CDR Files and Push Receivers

The local CDR file feature allows you to save RADIUS CDR data to a local CSV text file on local drive on the SBC. Local CDR file creation and storage can be used in addition to or independently of sending CDRs to RADIUS servers for calls. With the local CDR files, you can:

- Send the files to a remote server by configuring a push receiver
- Develop your own scripts for retrieving the files from the SBC

You configure the SBC to:

- Set directory path where you want to save local CDR files
- Set a maximum file size for the CSV file
- Set a maximum number of local CDR files
- Set an interval in which to close the existing local CDR file and begin writing a new file.

Once local CDR file creation is enabled, you can configure push receivers to send closed local CDR files to a server using FTP or SFTP protocols. Once sent off-box, the SBC deletes the local CDR file that was successfully sent.

### Local CDR File Format

The CDRs are written as comma-delimited ASCII records to files on the SBC. The types of records are controlled by the same accounting configuration parameters used for RADIUS. The fields of the comma-delimited entries correspond to RADIUS START, INTERIM, and STOP records. Using the accounting configuration, you can configure the SBC to record STOP records only.

Because the record types do not have consistent field positioning, any server parsing them would need to read the first field to determine the type and learn how to parse the remaining fields.

### Local CDR File Format Consistency

Unpopulated or unused fields in the RADIUS CDR are omitted from the locally-stored CSV file. This means that there is no fixed position for a RADIUS attribute across all CSV files. Instead, the missing values are skipped in the CSV file so that the order and appearance for attribute values can differ from record to record.

You can guarantee the placement of attributes in local CDR files with the **cdr-output-inclusive** parameter. With this enhancement enabled, RADIUS records sent to a RADIUS client contain even empty attributes with an integer, date and time, or IP address format; the default value is zero. In other words, when there is no value to report:

- An IP address attribute will report as 0.0.0.0
- A date and time attribute will report as 00:00:00.000 UTC Jan 01 1970
- An integer attribute value will report as 0

To maintain RFC 2865 and 2866 compliance, the Oracle Communications Session Border Controller will not send empty attributes that are string values to a RADIUS client. And when you enable this feature, the Oracle Communications Session Border Controller adds all attributes to the local CDR file.

### Masking local CDR fields

The content in local CDR files can also be controlled by using the [RADIUS Attribute Selection](#) feature. This lets you exclude call data fields from local CDR files.

## Decoding Local CDR File Contents

The Local CDR File contents do not follow a standard CSV file format.

- Fields in that are strings are enclosed in double quotes ("). Each string may contain commas, double quotes, and other similar characters that are not escaped.
- If a comma is part of a string already within double quotes, it will be replaced with a space character to avoid parsing failure.
- When you parse a CDR entry, the end will be indicated by a comma character after an even number of double quotes.

```
1,"<sip:0322911111@10.200.200.30:5066>;reason="unconditional",<sip:0322917676@10.200.200.30:5066>;reason="alias"",0,0,112
```

### Double Quote handling within Strings

If a double quote is part of a string already within double quotes, a second double quote can be added to avoid parsing failure. This is accomplished by adding the **escape-double-quotes** option in the **account-config** .

With double quotes enabled

```
ORACLE(account-config)# options +escape-double-quotes
```

For example, with the escape-double-quotes options enabled:

- /AfX8503412290""bcGhEfJeKqB0e@example.com

For example, without the escape-double-quotes options enabled:

- /AfX8503412290"bcGhEfJeKqB0e@example.com

## Generate Local CDR Layout Files

Numerous factors determine the layout of local CDR files. In order to obtain an accurate local CDR layout, the SBC can write a special CDR layout file that only includes the data layout for your local CDRs based on your configuration. You can then use this file to interpret local CDR files with the proper data field order, source and identification label.

You can configure the system to produce CDR layout files with the **dump\_csv\_format** command at the superuser prompt.

```
ORACLE# dump_csv_format
```

This function uses the same process, input and output mechanisms the system uses to produce local CDRs. While this command is activated, the system produces layout files instead of actual CDRs. After the layout files have been created, turn the generation feature off with the **no\_dump\_csv\_format** command.

Format files are written to the same directory as local CDR files, and they use the same naming convention as local CDR files. Refer to local CDR generation instructions to identify the files you intend to retrieve, based on your configuration for rotation, naming, file size, and so forth.

Perform this procedure in a maintenance window. Limit your sample calls to a single successful, and depending on your configuration, single unsuccessful call. The following is the general procedure used to capture local CDR layout files.

1. Turn on `dump_csv_format` from the system's enable prompt. The system stops generating local CDR files, generating local CDR format files instead.
2. Place a successful call.
3. Complete the call.
4. If you are configured for INTERIM generation upon an unsuccessful call, place an unsuccessful call.
5. Depending on your configuration, identify the file that has the format. For example, if using rotation you may decide to wait for the data to rotate from the temp file to be sure the file is closed.
6. Retrieve the layout file from the local CDR directory.
7. Turn off the feature using `no_dump_csv_format`. The system begins to generate local CDR files again.
8. Use the files to identify your CDR format and establish your collection and collation process.

### Local CDR Layout File Reference and Example

The first line of every record contains the following comma-delimited information:

```
"1", "Accounting Status", , "40", ["## START ##" | "## INTERIM ##" |  
"##STOP##"]
```

Each line after the initial line of each record contains the following comma-delimited information:

```
<CDR Attribute position>,<CDR Attribute Name>,<VSA Vendor>,<VSA Number>
```

The CDR Attribute name only presents the shorthand of the attribute. Cross-reference the VSA number with the RADIUS dictionary to obtain the full VSA name.

The following is an example of the first 10 rows of a CDR Layout file, start record.

```
1,"Accounting Status",,40,## START ##
2,"NAS IP Address",,4
3,"NAS Port",,5
4,"Accounting Session ID",,44
5,"Ingress Session ID",ACME,3
6,"Egress Session ID",ACME,4
7,"Session Protocol Type",ACME,43
8,"Session-Forked-Call-Id",ACME,171
9,"Generic ID",ACME,40
10,"Calling Station ID",,31
```

## Requirements

If you want to guarantee the CSV placement for RADIUS attribute values, you must use the entire RADIUS dictionary. You cannot use the RADIUS CDR abbreviation feature. Using an abbreviated form of the RADIUS dictionary results in adverse effects for the CSV file.

In your configuration, then, you must set the **vsa-id-range** parameter to use the entire range of attributes. Leaving this parameter blank disables abbreviation and all attributes are included. Alternatively, you can specify all of the parameters (by attribute number) that are used in the OS release loaded on your system.

See the [RADIUS CDR Content Control](#) section for more information.

## Local CDR File Naming Convention

The SBC creates filenames from the timestamp that the CDR file is opened for writing. The format is `cdrYYYYMMDDHHMM[a-j]`, where:

- YYYY=the year
- MM=the month
- DD=the day
- HH=the hour
- MM=the minute
- [a-j]=a suffix that provides additional discrimination in case of changing system time, setting the rotation time for this feature to one minute, or in case of another occurrence that might compromise the date and time

Your file name will resemble the following sample: `cdr200511151200`.

## Temporary File Naming for an Open CDR File

Before this release was introduced, the SBC used the same naming format for all CDR files: `cdrYYYYMMDDHHMM[a-j]`. If this is the naming convention you still want to use, you can do so simply by This mode offers no means of differentiating a file to which the SBC is writing information from any other closed file(s).

Open local CDR files have a **temp-** prefix added to the file name. The prefix helps you differentiate the file that is currently open from the other CDR files. As soon as the file is closed during rotation, the **temp-** prefix is removed.

You can revert to legacy behavior that omits the **temp-** prefix on open files by adding the **disable-temp-file** option to your accounting configuration.

```
ORACLE(account-config)# options +disable-temp-file
```

## Operational Details

This section offers details of SBC operations that effect temporary CDR file naming.

- **Reboot**—A system reboot can happen unexpectedly, or might be caused by your intentionally rebooting the system using the ACLI **reboot** command. When a reboot occurs, SBC closes the CDR file that was most recently opened (before the reboot) and names it according to the **cdrYYYYMMDDHHMM[a-j]** convention. It also opens a new file, which bears the **temp-** differentiation.
- **Activating a configuration**—If temporary CDR naming is enabled before and after you use the **activate-config** command, then the last opened file will be closed and have the **cdrYYYYMMDDHHMM[a-j]** name format. The SBC also opens a new file with the **temp-** prefix to which it will write data.

In the case where temporary CDR naming is enabled before you activate a configuration and disabled after it, the last open file is named according to the **cdrYYYYMMDDHHMM[a-j]** name format. The new file to which the SBC will write data is also in the **cdrYYYYMMDDHHMM[a-j]** name format. In other words, the SBC does not use the **temp-** prefix designation at all.

In the case where temporary CDR naming is disabled before you activate a configuration and enabled after it, the SBC closes the most recently opened file—which must have been in the **cdrYYYYMMDDHHMM[a-j]** name format. The SBC also opens a new file with the **temp-** prefix to which it will write data.

- **Changing the accounting configuration's administrative state**—When you disable the accounting configuration, the SBC renames the most recently opened file with the **temp-** prefix to the **cdrYYYYMMDDHHMM[a-j]** name format.

## HA Considerations for CDR Output Redundancy

The considerations in this section describes the Oracle Communications Session Border Controller's behavior when CDR output redundancy is enabled or disabled. You set CDR output redundancy in the accounting configurations **cdr-output-redundancy** parameter.

- **Enabled**—When you enable CDR output redundancy, both the Active and Standby systems rotate files. During CDR file rotation, if either the Active or the Standby rotates a file with the **temp-** prefix, the prefix disappears and the file name appears in the **cdrYYYYMMDDHHMM[a-j]** name format.  
The Active and the Standby systems always have the same files, including the CDR file with the **temp-** prefix. So the file exists on both systems.
- **Disabled**—When you have disables CDR output redundancy and switchover happens for any reason, it is key that there are no residual files with the **temp-** prefix. For this reason, the SBC handles the situation as follows:  
**Becoming Active**—When it transitions from Standby to Active, a SBC checks for any files with the **temp-** prefix, closes the file if it is open, and renames it according to the **cdrYYYYMMDDHHMM[a-j]** name format. These actions means that the file is not only



renamed, but that it is also rotated. Rotation triggers the creation of a new CDR file with the **temp-** prefix to use for new CDR data.

**Becoming Standby**—When it transitions from Active to Standby, a SBC closes the open **temp-** prefix file and renames it according to the **cdrYYYYMMDDHHMM[a-j]** name format. Rotation creates a new **temp-** prefix file on the Standby, which remains empty until it transitions back to the Active state.

- **Standby push**—provides the user with a mechanism to manage CDRs in a High Availability (HR) environment that prevents CDR loss during HA events. When the user configures this setting, the standby can SFTP files to the CDR server. When the decision is made to become standby the system looks for any un-pushed CDRs that are still present and pushes those to the CDR server.

This process addresses two potential data loss issues:

- When an active node fails over, there may be temporary CDRs that have not yet been pushed to the CDR server. If the standby cannot send the record to the CDR server itself, the data is lost, resulting in the call not being charged.
- Temporary CDRs files often contain incomplete data and can be present on both the active and standby SBCs. After a failover, and when the original active becomes the active again, it would send this temporary file to the CDR server and overwrite the file that had been sent from the previously active system.

The user sets this value using the syntax below.

```
ORACLE(account-config)# cdr-output-redundancy standby-push
```

Setting this value can also enhance the clarity of CDR file names. This would also require that the applicable **account-config** have its **file-seq-number** parameter enabled. The system then includes information within the filename to distinguish whether the file came from the active or standby node. This prevents the standby from overwriting CDRs already on the server. This naming convention adds two prefixes to the CDR filename.

```
XXXX-YYYY-CDR201610171015-000000050
```

- XXXX - The filename-prefix defined in your **push-recipient** setting
- YYYY - The host name of the SBC

The **standby-push** value requires that the applicable **account-config** operate over a management (wancom) interface. Configuration verification fails if the user sets this value to an **account-config** operating over a media interface.

All parameters are RTC supported.

#### Note:

Before you upgrade from a release prior to S-CZ7.2.0 to S-CZ7.2.0 or later, you must set the **cdr-output-redundancy** parameter to **enabled** for the Standby to upgrade and sync properly. You can then change the parameter to **disabled** afterwards, if needed.

### Caveats

As described above, when the system reboots for any reason or when you issue an **activate-config**, the SBC checks for CDR files with the **temp-** prefix and renames to the usual **cdrYYYYMMDDHHMM[a-j]** format.

However, if you change the accounting configuration's file-path value and subsequently the system either reboots or you activate your configuration, the SBC will be unable to check for files with the **temp-** prefix in the old file path. And so it will also be unable to rename them. The SBC checks the new path only.

## Call Detail Record Sequence Number in Filename

To assist in the identification of lost Call Detail Record (CDR) files, the customer can enable the **file-seq-number** attribute to assign a sequence number to append to the file. A separate configuration element, **temp-remote-file**, allows for the prepending of the characters "tmp-" to CDR files during transfer.

Sometimes local CDR transmission failures occur due to underlying network or infrastructure issues. Customers can identify missing files through the combination of a timestamp (YYYYMMDDMM) and 9-digit unique sequence numbers (SNs) appended to the file. This behavior is enabled through the **file-seq-number** attribute. The SN will start from one at boot time. This attribute replaces the use of alpha characters (a-z) appended to the CDR file name when more than one file is created in the same minute.

## Local CDR File Storage Directories

The SBC only allows local storage of CDRs to the `/opt` directory. If you try to save to another directory (such as `/code` or `/boot`), you will receive an error message.

Setting the location to `/opt/logs` may cause the `package-logfiles` command and the `package-crashfiles` command to fail. Instead, use `/opt/accounting`.

If you are using the ACLI and enter an inappropriate directory, the ACLI will issue an error message.

## Local CDR File Size and Rotation

You can configure maximum file size, maximum number of local CSV files to store, and the interval at which the files rotate.

The SBC saves up to the file size limit (**max file size**) and maintains only number of files that you configure (**max files**). When the maximum file size is reached, the SBC closes that file and begins writing VSA attributes and values to a new local CDR file. When it is time for the SBC to write the **max files** + 1 file, the oldest file is deleted so that the newest one can be stored.

You can set the period of time at which the SBC ends writing a local CDR file and begins writing data to a new file. This is the file rotate time and is configured in the **file-rotate-time** parameter.

## Local CDR File Compression

You can configure the SBC to compress local CDRs in zip format to save disk space by setting the **file-compression** parameter to enabled.

## Local CDR File Redundancy

The SBC can create a redundant copy of the local CDR files, and store them on the standby system in the HA node.

This enhancement to the CDR storage feature ensures against data loss if, for example, an active SBC fails immediately before sending the files off-box to a push receiver. The standby has a duplicate set of records that it sends. This feature is enabled with the **CDR output redundancy** parameter found in the **account config** configuration element.

## Caveats for H.323

H.323 calls proceed without interruption over an HA node in the event of a failover from one SBC to another, and RADIUS records are generated and duplicated across the active and standby systems in an HA node. However if a switchover occurs during an H.323 call (that has been initiated, but not completed), the newly active (formerly standby) system will not generate RADIUS Stop records when the call completes.

## Configuring Local CDR Files

This procedure explains how to enable and customize creation of local CDR files.

1. Access the **account-config** configuration element.

```
ORACLE# configure terminal
ORACLE(configure)# session-router
ORACLE(session-router)# account-config
ORACLE(account-config)#
```

2. **file-output**—Enable this parameter for the SBC to create comma-delimited CDRs (generated from RADIUS records). By default, this parameter is disabled.
3. **file-path**—You must configure this path for the CDR push feature to work. Set the path to use on the SBC for file storage:

- /opt
- /opt/logs

To use FTP push, you must configure a usable path.

### Note:

When a Hard Disk Drive is available, you may opt to store CDRs in the data-disk.

4. **max-file-size**—Set the maximum CDR file size in bytes. The default and minimum value is 1000000. Oracle recommends you limit local CDR storage on your system to 30M. For example, if you retain the **max-file-size** default, set **max-files** to 30. However, if you are using a Storage Expansion Module the maximum value is 108.
5. **max-files**—Set the maximum number of files to be stored on the SBC at one time. The parameter's value range is from 0 to unlimited. The user should consider the max-file-size setting, the 30M recommendation, and their preferences to specify this value. The default is 5.
6. **file-sequence-number**—set this to enabled for the system to assign a 9 digit file sequence number to append to a CDR file. The default is disabled.
  - **enabled | disabled**
7. **file-compression**—set this to enabled for the system to compress closed local CDR files in .zip format.
8. **file-rotate-time**—Set how often in minutes you want to rotate the stored files; the SBC overwrites the oldest file first. The minimum rotation time is 0 minutes, the default. Leaving this value set to the default means that the SBC does not rotate the files.
9. **cdr-output-redundancy**—Set this parameter to enabled for the SBC to store a redundant copy of the local CSV file to the standby HA node. Set this parameter to standby-push to enable the function and enable local storage and implement push capabilities on an HA deployment's standby to protect against CDR data loss.
10. **vsa-id-range**—Either leave this parameter blank (default), or enter the complete range of VSAs loaded on your system. The following example shows what you might enter to use all of the VSAs for for a system that is not running QoS.

```
ORACLE(account-config)# vsa-id-range 1-4,10-14,20-24,28,29,32-71,74-136
```
11. **cdr-output-inclusive**—When disabled (default), the system excludes fields that have no data from the CSV file. Set to enabled to make the system include all fields in every CSV file. This ensures that there are always the same number of fields in all equivalent records. Start records would always have the same number of fields. The same would be true of interim and stop records.
12. Type **done** to save your configuration.

## Local CDR File Delete Warning

You can configure the SBC to initiate an alarm and send an SNMP trap when the oldest local CDR file was deleted under fault conditions. This feature is enabled with the **file delete alarm** parameter.

The SBC deletes a local CDR file in the following three cases:

1. After the local CDR file has been successfully transferred to a push receiver
2. The number of local CDR files exceed the limit configured in the **account-config, max-files** parameter
3. No free disk space remains on the partition where the local CDR files are written:  
**account-config, file-path**

If a local CDR file is deleted after it was successfully uploaded to a push receiver, no fault is triggered because this is standard, expected operation. But if a local CDR file is

deleted for case 2 or 3 above, it is considered a fault condition initiating an alarm and SNMP trap.

## Local CDR File Delete Alarm

The CDR file delete alarm is configured in **account config** configuration element by enabling the **file-delete-alarm** parameter. This is a minor severity alarm and is non-health affecting. This alarm has no clearing condition and must be manually cleared.

## Local CDR File Delete SNMP Trap

Under the same circumstances that cause a CDR file delete alarm, an SNMP trap will be sent to all configured trap-receivers. The `apSysMgmtCdrFileDeleteTrap` trap contains the following information:

- File Name—name of the file that was deleted

## Local CDR Push Receivers

Local CDR push receivers are used to transfer local CDR files to a remote server on a periodic basis. You configure this feature by defining push receivers with a remote IP address and port and login credentials for FTP and SFTP servers. At the configured time interval (**file rotate time**), the SBC closes the current file, and transfers the files that are complete and have not yet been pushed; including the just-closed-file. These files are uploaded to the remote servers at a specified **remote-path**. You can choose either `ftp` or `sftp` protocols to access the remote servers.

In the case that all push receivers are unreachable, then local CDR files continue to be written to local file system until the push receivers return to service. Once a push receiver becomes reachable, the SBC transfers all local CDR files to the remote server automatically. After all local CDR files have been successfully transferred to server, they are deleted from the local volume.

You can optionally set the **temp-remote-file** attribute so the characters "tmp-" are prepended to the CDR file during transfer. Once delivered, the file will be renamed on the remote host to remove "tmp-".

## Secure FTP Push Configuration

You can configure the Oracle Communications Session Border Controller (SBC) to securely log on to a push receiver using one of the following methods that creates a secure connection.

Password authentication—

1. Set the **protocol** parameter on the push receiver to SFTP.
2. Configure a username and password.
3. Leave the **public-key** parameter blank.
4. Import the host key from the SFTP server to the SBC as a known-host key. See "SSH Key Management" in the *Configuration Guide*.

Public key authentication—

1. Set the **protocol** parameter on the push receiver to SFTP.

2. Configure the username.
3. Leave the **public-key** parameter blank, regardless of authentication type.
4. Export the SBC's public key with the `show security public-host-key rsa` command.
5. Append the SBC's public-key to the SFTP server's `authorized_keys` file.
6. Import the host key from the SFTP server to the SBC as a known-host key.  
See "SSH Key Management" in the *Configuration Guide*.

It is often difficult to determine whether the SFTP server uses its RSA key or its DSA key for its server application. For this reason, Oracle recommends that you import both the RSA key and the DSA key to the SBC to ensure a successful FTP Push.

It is also common for the SFTP server to run the Linux operating system. For Linux, the command `ssh-keygen -e` creates the public key that you need to import to the SBC. The `ssh-keygen-e` command sequence requires you to specify the file export type, as follows.

```
[linux-vpn-1 ~]# ssh-keygen -e
Enter file in which the key is (/root/.ssh/id_rsa/): /etc/ssh/
ssh_host_rsa_key.pub
```

If you cannot access the SFTP server directly, but you can access it from another Linux host, use the `ssh-keyscan` command to get the key. An example command line follows.

```
root@server:~$ ssh-keyscan -t rsa sftp.example.com
```

## Multiple Push Receivers

SBC (SBC) supports up to five CDR push receivers for use with the local file storage and FTP push feature. For each receiver you configure, you can set the file transfer protocol that you want to use. (FTP or SFTP). The system uses the push receivers according to the priorities you assign by setting a 0 through 4 priority number to the server. 0 is the highest priority, and 4 (default) is the lowest.

Based on the priority level you set, the SBC uses the strategy that you set to select a CDR push receiver. If the highest priority push receiver selected using the strategy becomes unavailable, the SBC uses the strategy (hunt, round robin) to select another.

This feature is dynamically configurable. When you change the configuration, the SBC updates the list of push receivers if it has changed.

## Deprecated ACLI Configuration

The following parameters in the `account-config` configuration element are deprecated:

- `ftp-address`
- `ftp-port`
- `ftp-user`
- `ftp-password`
- `ftp-remote-path`

These parameters will only be used if no **account-config**, **push-receiver** configuration elements have been defined. All new push receivers must be defined in the **account-config**, **push-receiver** configuration element.

## Configuring Local CDR Push Receivers

This procedure explains how to enable and customize a push receiver configuration that will transfer closed local CDR files to remote servers.

1. Access the **account-config** configuration element.

```
ORACLE# configure terminal
ORACLE(configure)# session-router
ORACLE(session-router)# account-config
ORACLE(account-config)#
```

2. **ftp-push**—Set the state of FTP push feature to **enabled**. It is disabled by default.
3. Type **push-receiver** and press Enter.

```
ORACLE(account-config)# push-receiver
```

You can now begin to configure a push receiver.

4. **server**—Enter the IP address of this push receiver.
5. **port**—Enter the port number of this push receiver.
6. **remote-path**—Enter the remote pathname where local CDR files should be written on the push receiver.
7. **filename-prefix**—Enter the filename prefix (as a string) to prepend to the Local CDR files. The SBC does not rename local files. There is no default for this parameter.
8. **priority**—Enter a number 0 through 4 to set the priority of this push receiver in relation to the others you configure on the system. The highest priority, and the push receiver the system uses first, is 0. The lowest priority, and the push receiver the system uses last, is 4 (the default).
9. **temp-remote-file**—set the state of this element to enabled for the system to prepend the characters "tmp-" to a CDR file during transfer. When the transfer ends successfully, the system removes the characters "tmp-". The default is disabled
  - **enabled | disabled**
10. **protocol**—Enter **SFTP** or **FTP**. Consider the **port** value you configured earlier.
11. **username**—Enter the username the SBC uses when connecting to this push receiver. There is no default for this parameter. This parameter is always required.
12. **password**—Enter the password corresponding to the username the SBC uses when connecting to this push receiver. There is no default for this parameter. You can leave this field blank if you are using public key authentication. Profile configuration is required for both password and public key authentication.
13. **public-key**—Do not configure this field. Public key operations are performed outside of this configuration element. See "SSH Key Management" in the *Configuration Guide*.

14. **ftp-strategy**—Set the strategy you want the SBC to use when selecting from multiple push receivers. The default is **hunt**.
  - **Hunt**—The SBC selects the push receiver from the available list according the priority level. The system uses this strategy as its default.
  - **Failover**—The SBC selects the push receiver based on priority level and will continue to use that same push receiver until it fails over.
  - **RoundRobin**—The SBC selects push receivers systematically one after another, balancing the load among all responsive push receivers.
  - **FastestRTT**—The SBC selects the push receiver based on best average throughput. For this situation, throughput is the number of bytes transferred divided by the response time. The system uses a running average of the five most recent throughput values to accommodate for network load fluctuations.
15. **ftp-max-wait-failover**—Enter the amount of time in seconds to wait before the SBC declares a push receiver to have failed over. This default value for this parameter is **60**.
16. Type **done** to save your configuration.

## Monitoring CDR Push Receivers

The SBC provides several mechanisms to monitor push receivers

### ACLI Show Command

You can use the ACLI **show radius cdr** command to view information about CDR push receivers. The existing display for this command has been extended to include information that looks like the following:

```
***** CDR Push Receiver Display Start*****
strategy = FastestRTT, maxwaitfailover = 10, number of receivers = 1
----- 172.30.0.70:21 -----
cdrpush-receiver = 172.30.0.70:21, state = READY, priority = 4
remote path = /home/acme, remote prefix = vik, protocol = ftp
username = acme, password = *****, publickey =
FTP rtt = 0, FTP successes = 0, FTP failures = 0
FTP timeouts = 0, FTP Delays = 0, FTP Put failures = 0
FTP conn failures = 0, FTP terminates = 0, FTP triggered terminates = 0
```

### SNMP Traps and Alarms

The SBC sends traps when a single push receiver or all push receivers become unavailable.

- When one CDR push receiver becomes unavailable, the **CDR\_PUSH\_RECEIVER\_FAIL\_TRAP** trap is sent and a minor alarm is generated.
- When all of the configured CDR push receivers become unavailable, the **CDR\_ALL\_PUSH\_RECEIVERS\_FAIL\_TRAP** is sent and a major alarm is generated.

When one or more of the push receivers comes back, the **CDR\_ALL\_PUSH\_RECEIVERS\_FAIL\_CLEAR\_TRAP** is sent and the alarm is cleared.

The SBC sends out traps and triggers corresponding alarms when it encounters failure when attempting to transfer local CDR files. One set of traps is used for single-instance push receiver failures; another set is used when all receivers fail. They are part of the `apSysMgmtCDRPushReceiverNotificationsGroup`.



All of the traps contain information about the type of push receiver, the address of the push receiver, and the failure reason code.

The trap and corresponding clearing trap for single push receiver failure are:

- apSysMgmtCDRPushReceiverFailureTrap
- apSysMgmtCDRPushReceiverFailureClearTrap

A minor alarm is generated when the apSysMgmtCDRPushReceiverFailureTrap is sent.

The trap and corresponding clearing trap for global push receiver failure are:

- apSysMgmtCDRAAllPushReceiversFailureTrap
- apSysMgmtCDRAAllPushReceiverFailuresClearTrap

A major alarm is generated when the apSysMgmtCDRAAllPushReceiversFailureTrap is sent.

# 5

## CDR Attribute Reference

This section describes the Vendor Specific Attributes (VSA) that the Oracle Communications Session Border Controller supports.

The Oracle Communications Session Border Controller supports CDRs through RADIUS reporting with additional VSAs to include information that is not available with the standard RADIUS session information. CDRs provide billing information on sessions traversed through a system, as well as troubleshooting information, fraud detection, fault diagnostics, and service monitoring.

CDRs can contain information about recent system usage such as the identities of sources (points of origin), the identities of destinations (endpoints), the duration of each call, the amount billed for each call, the total usage time in the billing period, the total free time remaining in the billing period, and the running total charged during the billing period. VSAs are defined by vendors of remote access servers in order to customize how RADIUS works on their servers.

### Standard RADIUS Attributes

This section describes the standard RADIUS attributes that the SBC supports. These attributes appear along with VSAs (Vendor-Specific Attributes) in the CDRs that the SBC generates.

The [Standard RADIUS Attributes Dictionary](#) is a dictionary of the standard RADIUS attributes included in Accounting Request messages sent by the SBC to the RADIUS server. The CDR event information determines which messages are generated and which RADIUS attributes are included in the messages. Standard RADIUS messages and attributes are used whenever possible; however, RADIUS does not have attributes to record all important session information.

Possible messages are:

- Start—Marks the start of service delivery and describes the type of service being delivered and the user to whom it is being delivered
- Interim-Update—Indicates to the accounting server that the session parameters have changed
- Stop—
  - Marks the end of service delivery
  - Describes the type of service that was delivered
  - Sometimes describes statistics such as elapsed time, input and output octets, or input and output packets
- On—Marks the start of accounting
- Off—Marks the end of accounting

VSAs are used to record the necessary session information missing from this list of standard RADIUS attributes.

For more information about RADIUS, see to the following Internet Engineering Task Force Request for Comments (IETF RFCs):

- RFC 2865, Remote Authentication Dial In User Service (RADIUS), Rigney, et al., June 2000 (<http://www.ietf.org/rfc/rfc2865.txt>)
- RFC 2866, RADIUS Accounting, C. Rigney, June 2000 (<http://www.ietf.org/rfc/rfc2866.txt>)

## Standard RADIUS Attributes Dictionary

The table below lists and describes standard RADIUS attributes.

Attribute Name	Attribute Description	Attribute Value	Attribute Value Type	Messages
NAS-IP-Address	IP address of the SIP proxy or the H.323 stack's call signaling address.	4	IP address	<ul style="list-style-type: none"> <li>• Start</li> <li>• Interim-Update</li> <li>• Stop</li> <li>• On</li> <li>• Off</li> </ul>
NAS-Port	SIP proxy port or the H.323 stack's call signaling RAS port.	5	integer	<ul style="list-style-type: none"> <li>• Start</li> <li>• Interim-Update</li> <li>• Stop</li> <li>• On</li> <li>• Off</li> </ul>
Called-Station-Id	To field value of the SIP INVITE message (a type of message used to initiate a session) or the calledPartyNumber of the H.323 message.	30	string	<ul style="list-style-type: none"> <li>• Start</li> <li>• Interim-Update</li> <li>• Stop</li> </ul>
Calling-Station-Id	From field value of the SIP INVITE message or the callingPartyNumber of the H.323 message.	31	string	<ul style="list-style-type: none"> <li>• Start</li> <li>• Interim-Update</li> <li>• Stop</li> </ul>

Attribute Name	Attribute Description	Attribute Value	Attribute Value Type	Messages
NAS-Identifier	Value, if any, set in the optional NAS-ID field for the accounting server that you configure as part of the accounting configuration. This identifier sets the value that the remote server (the accounting server) uses to identify the SBC so that RADIUS messages can be transmitted. The remote server to which the accounting configuration will send messages uses at least one of two pieces of information for identification: NAS IP address: always included in the accounting message NAS identifier: configured in the NAS-ID parameter of the accounting server; if configured, the NAS identifier is sent to the remote server This attribute only appears if a value is configured in the NAS-ID field.	32	string	<ul style="list-style-type: none"> <li>• Start</li> <li>• Interim-Update</li> <li>• Stop</li> <li>• On</li> <li>• Off</li> </ul>
Acct-Status-Type	Whether this Accounting Request marks the beginning of the RADIUS message (Start), the middle (Interim-Update), or the end (Stop), and whether the accounting function is on or off (Accounting-On or Accounting-Off).	40	integer	<ul style="list-style-type: none"> <li>• Start (1)</li> <li>• Interim-Update</li> <li>• Stop (2)</li> <li>• On</li> <li>• Off</li> </ul>
Acct-Session-Id	Either the Call-ID field value of the SIP INVITE message, the callIdentifier of the H.323 message, or RADIUS client information.	44	string	<ul style="list-style-type: none"> <li>• Start</li> <li>• Interim-Update</li> <li>• Stop</li> <li>• On</li> <li>• Off</li> </ul>
Acct-Session-Time	How much time in seconds (or milliseconds if so configured) the user has received service.	46	integer	<ul style="list-style-type: none"> <li>• Interim-Update</li> <li>• Stop</li> <li>• Off</li> </ul>
Acct-Terminate-Cause	How or why the session ended.	49	integer	<ul style="list-style-type: none"> <li>• Stop</li> <li>• Off</li> </ul>

## RADIUS Accounting Termination Causes

The table below describes the possible session termination causes for the Acct-Terminate-Cause RADIUS attribute.

RADIUS Termination Cause	Related Integer Value (per RFC 2059)	Termination Event	Message
User Request	1	A SIP BYE message.	Stop
User Error	17	Input from user is erroneous; for example, SIP signaling failed to establish the session. Used in combination with the Cisco Systems Disconnect Cause. (This termination cause is not used for H.323.)	Stop
Lost Service	3	Service cannot be sustained for reasons such as a lost connection.	Stop
idle-timeout	4	Idle timer expired.	Stop
session-timeout	5	Maximum session length timer expired.	Stop
Admin Reset	6	SBC hard reset occurred: A hard reset occurs when you use the front panel's orange Reset button; it reboots the SBC.	Off
Admin Reboot	7	SBC gracefully rebooted.	Off
NAS Request	10	RADIUS server is disabled; session terminated for non-error reason.	Off

## Cisco Systems RADIUS Decodes

The following table is a dictionary of the Cisco Systems (vendor identification number is 9) accounting VSAs. These attribute names are vendor-specific and subject to change without notice.

You can use the information in this table to translate the Cisco Systems VSAs that sometimes appear in SBC RADIUS messages into a more human-readable form.

Attribute Name	Attribute Description	Attribute Value	Attribute Value Type	Messages
Setup Time	The SETUP message is used to request a connection (and therefore corresponds with the SIP INVITE). <b>Start</b> record—Time that the first SIP INVITE or H.323 SETUP message was received. <b>Interim</b> record—Time that the applicable SIP REINVITE message was received. <b>Stop</b> record—Time that the last SIP REINVITE message was received.	25	string	Start Interim Stop
Connect Time	Time that a SIP or H.323 session was accepted. This is the time a 200 OK SIP response to the SIP INVITE message was received or the time that a call ANSWERED/CONNECTED response to the H.323 SETUP message was received.	28	string	Start Interim-Update Stop

Attribute Name	Attribute Description	Attribute Value	Attribute Value Type	Messages
Disconnect Time	Time that a SIP BYE or H.323 Release Complete message was received or the session terminated. This is the time a SIP INVITE or H.323 SETUP transaction terminates for any reason.	29	string	Stop
Disconnect Cause	SIP Reasons for Disconnection (normal, redirection, client error, network error, global error, time-out, or user abandon) or the H.323 Release Complete Reason code (bad format address, unavailable, destination rejection, adaptive busy, etc.). For more information, refer to this guide's Mappings and Disconnect Cause Values section.	30	string	Stop

## Oracle RADIUS VSAs

Oracle's vendor identification number is 9148. This number refers to the 4-octet VSA Vendor-ID field. The high-order octet is 0 and the low-order 3 octets are the SMI Network Management Private Enterprise Code of the Vendor in network byte order, defined in the Assigned Numbers RFC (<http://www.faqs.org/rfcs/rfc1700.html>; Reynolds, J. and J. Postel, Assigned Numbers, STD 2, RFC 1700, October 1994).

The table in this section is a dictionary of Oracle's accounting VSAs. You can use this information to translate the Oracle VSAs in SBC RADIUS messages into human-readable form. Oracle maintains VSA dictionary definition files for the most popular RADIUS distributions; ask your Oracle account representative for details.

Grouped according to attribute function, this table contains the following sections:

- **General Flow Attributes**—Overall traits of the media flow, these attributes appear in all CDRs regardless of the session's protocol; these attribute fields are only populated if there are media flows
- **Inbound Flow Attributes**—Detailed traits of the inbound media flow (including realm, remote IP address and port, and local IP address and port); these attribute fields are only populated if there are media flows
- **Outbound Flow Attributes**—Detailed traits of the outbound media flow (including realm, remote IP address and port, and local IP address and port); these attribute field are only populated if there are media flows
- **Session Attributes**—Information about the protocol type, ingress and egress realms used, and an identifier that links the H.323 and SIP legs of a call requiring IWF. In addition, SIP reporting includes specific information for Short Message Service (SMS) traffic, defined within the SBC as message events reported using CDR STOP records. SIP reporting also includes detail on VoLTE sessions to support management within IMS constructs.
- **QoS Attributes**—RADIUS call records are instantiated by individual signaling applications on the SBC. The SBC writes the following additional parameters to the call record for QoS (Quality of Service):
  - MSRP Total Packets

- MSRP Total Octets
- RTP Lost packets
- RTP Jitter
- RTP Maximum Jitter
- RTCP Lost packets
- RTCP Jitter
- RTCP Latency
- RTCP Maximum Latency
- RTP Total Packets
- RTP Total Octets

Only RADIUS Stop records contain QoS information. For non-QoS calls, the attributes appear in the record, but their values are always be zero (0). When you review the list of QoS VSAs, please note that “calling” in the attribute name means the information is sent by the calling party and called in the attribute name means the information is sent by the called party.

Examples of how this information appears in CDRs appears in Appendix B of this guide. Please note that the contents of Interim-Update messages do not depend on what events cause a Start message to be generated.

## R-Factor and MOS

The SBC reports R-Factor and MOS data for the calling and called segments at the end of a session. This information appears in RADIUS CDRs, and in the Oracle VSA dictionary:

- Acme-Calling-R-Factor (151)
- Acme-Calling-MOS (152)
- Acme-Called-R-Factor (153)
- Acme-Called-MOS (154)

 **Note:**

These values are reported as \* 100 in order to appear as integers.

## Media Flow Attributes

The SBC records media flow attributes in RADIUS CDRs, and there can be multiple flows per session. In order to distinguish between the two flows that appear for a basic session (forward and reverse), the SBC supports unique media flow attribute names.

The term flow-set represents a pair of media flows, where one is the forward flow and one is the reverse. The flow attributes described in the table below have the designation FS1 or FS2, which identifies it as either the first or the second flow-set. In addition, all non-QoS attributes have a direction indicator: F for forward, and R for reverse.

## MSRP Attributes

An additional group of MSRP media flow attributes are captured in the Acme-Extended-Attributes VSA. See [Oracle RADIUS Acme-Extended-Attributes VSAs](#) for information on configuring them.

Attribute Name	Attribute Description	Attribute Value	Attribute Value Type	Messages
Acme-CDR-Sequence-Number	Sequence number (that increases by 1) the SBC generates; recorded in each CDR.	59	integer	Start Interim-Update Stop
Acme-Intermediate-Time	Time interval at which periodic interim records are generated during a call.	63	string	Interim-Update
Acme-Local-Time-Zone	Local GMT/UTC time zone that is provisioned on the SBC.	57	string	Start Interim-Update Stop
Acme-Firmware-Version	Current software version running on the SBC.	56	string	Start Interim-Update Stop

This table lists and describes general flow attributes.

Attribute Name	Attribute Description	Attribute Value	Attribute Value Type	Messages
Acme-FlowID_FS1_F	Unique identifier for every media flow processed by the SBC, flow-set 1 forward direction. This VSA always prefaces other flow information.	1	string	Start Interim-Update Stop
Acme-FlowID_FS1_R	Unique identifier for every media flow processed by the SBC, flow-set 1 reverse direction. This VSA always prefaces other flow information.	78	string	Start Interim-Update Stop
Acme-FlowID_FS2_F	Unique identifier for every media flow processed by the SBC, flow-set 2 forward direction. This VSA always prefaces other flow information.	90	string	Start Interim-Update Stop



Attribute Name	Attribute Description	Attribute Value	Attribute Value Type	Messages
Acme-FlowID_FS2_R	Unique identifier for every media flow processed by the SBC, flow-set 2 reverse direction. This VSA always prefaces other flow information.	112	string	Start Interim-Update Stop
Acme-FlowType_FS1_F	Codec that describes the flow, flow-set 1 forward direction: PCMU, PCMA, G722, G726, G723, G728, G729, H261, H263, T38.	2	string	Start Interim-Update Stop
Acme-FlowType_FS1_R	Codec that describes the flow, flow-set 1 reverse direction: PCMU, PCMA, G726, G723, G728, G729, H261, H263, T38.	79	string	Start Interim-Update Stop
Acme-FlowType_FS2_F	Codec that describes the flow, flow-set 2 forward direction: PCMU, PCMA, G726, G723, G728, G729, H261, H263, T38.	91	string	Start Interim-Update Stop
Acme-FlowType_FS2_R	Codec that describes the flow, flow-set 2 reverse direction: PCMU, PCMA, G726, G723, G728, G729, H261, H263, T38.	113	string	Start Interim-Update Stop

This table describes inbound flow attributes.

Attribute Name	Attribute Description	Attribute Value	Attribute Value Type	Messages
Acme-Flow-In-Realm_FS1_F	Inbound realm identifier for flow-set 1, forward direction.	10	string	Start Interim-Update Stop
Acme-Flow-In-Realm_FS1_R	Inbound realm identifier for flow-set 1, reverse direction.	80	string	Start Interim-Update Stop

Attribute Name	Attribute Description	Attribute Value	Attribute Value Type	Messages
Acme-Flow-In-Realm_FS2_F	Inbound realm identifier for flow-set 2, forward direction.	92	string	Start Interim-Update Stop
Acme-Flow-In-Realm_FS2_R	Inbound realm identifier for flow-set 2, reverse direction.	114	string	Start Interim-Update Stop
Acme-Flow-In-Src-Addr_FS1_F	Inbound source address (remote) information for flow-set 1, forward direction.	11	IP address	Start Interim-Update Stop
Acme-Flow-In-Src-Addr_FS1_R	Inbound source address (remote) information for flow-set 1, reverse direction.	81	IP address	Start Interim-Update Stop
Acme-Flow-In-Src-Addr_FS2_F	Inbound source address (remote) information for flow-set 2, forward direction.	93	IP address	Start Interim-Update Stop
Acme-Flow-In-Src-Addr_FS2_R	Inbound source address (remote) information for flow-set 2, reverse direction.	115	IP address	Start Interim-Update Stop
Acme-Flow-In-Src-Port_FS1_F	Inbound source (remote) port information for flow-set 1, forward direction.	12	integer	Start Interim-Update Stop
Acme-Flow-In-Src-Port_FS1_R	Inbound source (remote) port information for flow-set 1, reverse direction.	82	integer	Start Interim-Update Stop
Acme-Flow-In-Src-Port_FS2_F	Inbound source (remote) port information for flow-set 2, forward direction.	94	integer	Start Interim-Update Stop
Acme-Flow-In-Src-Port_FS2_R	Inbound source (remote) port information for flow-set 2, reverse direction.	116	integer	Start Interim-Update Stop

Attribute Name	Attribute Description	Attribute Value	Attribute Value Type	Messages
Acme-Flow-In-Dst-Addr_FS1_F	Inbound destination (local) address information (the IPv4 address field value of the steering pool configuration) for flow-set 1, forward direction.	13	IP address	Start Interim-Update Stop
Acme-Flow-In-Dst-Addr_FS1_R	Inbound destination (local) address information (the IPv4 address field value of the steering pool configuration) for flow-set 1, reverse direction.	83	IP address	Start Interim-Update Stop
Acme-Flow-In-Dst-Addr_FS2_F	Inbound destination (local) address information (the IPv4 address field value of the steering pool configuration) for flow-set 2, forward direction.	95	IP address	Start Interim-Update Stop
Acme-Flow-In-Dst-Addr_FS2_R	Inbound destination (local) address information (the IPv4 address field value of the steering pool configuration) for flow-set 2, reverse direction.	117	IP address	Start Interim-Update Stop
Acme-Flow-In-Dst-Port_FS1_F	Inbound destination (local) port information (a port in the range between the start port and end port field values of the steering pool configuration) for flow-set 1, forward direction.	14	integer	Start Interim-Update Stop

Attribute Name	Attribute Description	Attribute Value	Attribute Value Type	Messages
Acme-Flow-In-Dst-Port_FS1_R	Inbound destination (local) port information (a port in the range between the start port and end port field values of the steering pool configuration) for flow-set 1, reverse direction.	84	integer	Start Interim-Update Stop
Acme-Flow-In-Dst-Port_FS2_F	Inbound destination (local) port information (a port in the range between the start port and end port field values of the steering pool configuration) for flow-set 2, forward direction.	96	integer	Start Interim-Update Stop
Acme-Flow-In-Dst-Port_FS2_R	Inbound destination (local) port information (a port in the range between the start port and end port field values of the steering pool configuration) for flow-set 2, reverse direction.	118	integer	Start Interim-Update Stop

This table lists and describes outbound flow attributes.

Attribute Name	Attribute Description	Attribute Value	Attribute Value Type	Messages
Acme-Flow-Out-Realm_FS1_F	Outbound realm identifier for flow-set 1, forward direction.	20	string	Start Interim-Update Stop
Acme-Flow-Out-Realm_FS1_R	Outbound realm identifier for flow-set 1, reverse direction.	85	string	Start Interim-Update Stop
Acme-Flow-Out-Realm_FS2_F	Outbound realm identifier for flow-set 2, forward direction.	97	string	Start Interim-Update Stop

Attribute Name	Attribute Description	Attribute Value	Attribute Value Type	Messages
Acme-Flow-Out-Realm_FS2_R	Outbound realm identifier for flow-set 2, reverse direction.	119	string	Start Interim-Update Stop
Acme-Flow-Out-Src-Addr_FS1_F	Outbound source (local) address information (the IPv4 address field value of the steering port configuration) for flow-set 1, forward direction.	21	IP address	Start Interim-Update Stop
Acme-Flow-Out-Src-Addr_FS1_R	Outbound source (local) address information (the IPv4 address field value of the steering port configuration) for flow-set 1, reverse direction.	86	IP address	Start Interim-Update Stop
Acme-Flow-Out-Src-Addr_FS2_F	Outbound source (local) address information (the IPv4 address field value of the steering port configuration) for flow-set 2, forward direction.	98	IP address	Start Interim-Update Stop
Acme-Flow-Out-Src-Addr_FS2_R	Outbound source (local) address information (the IPv4 address field value of the steering port configuration) for flow-set 2, reverse direction.	120	IP address	Start Interim-Update Stop
Acme-Flow-Out-Src-Port_FS1_F	Outbound source (local) port information for flow-set 1, forward direction (a port in the range between the start port and end port field values of the steering port configuration).	22	integer	Start Interim-Update Stop

Attribute Name	Attribute Description	Attribute Value	Attribute Value Type	Messages
Acme-Flow-Out- Src-Port_FS1_R	Outbound source (local) port information for flow-set 1, reverse direction (a port in the range between the start port and end port field values of the steering port configuration).	87	integer	Start Interim-Update Stop
Acme-Flow-Out- Src-Port_FS2_F	Outbound source (local) port information for flow-set 2, forward direction (a port in the range between the start port and end port field values of the steering port configuration).	99	integer	Start Interim-Update Stop
Acme-Flow-Out- Src-Port_FS2_R	Outbound source (local) port information for flow-set 2, reverse direction (a port in the range between the start port and end port field values of the steering port configuration).	121	integer	Start Interim-Update Stop
Acme-Flow-Out- Dst-Addr_FS1_F	Outbound destination (remote) address information for flow-set 1, forward direction.	23	IP address	Start Interim-Update Stop
Acme-Flow-Out- Dst-Addr_FS1_R	Outbound destination (remote) address information for flow-set 1, reverse direction.	88	IP address	Start Interim-Update Stop
Acme-Flow-Out- Dst-Addr_FS2_F	Outbound destination (remote) address information for flow-set 2, forward direction.	100	IP address	Start Interim-Update Stop

---

Attribute Name	Attribute Description	Attribute Value	Attribute Value Type	Messages
Acme-Flow-Out-Dst-Addr_FS2_R	Outbound destination (remote) address information for flow-set 2, reverse direction.	122	IP address	Start Interim-Update Stop
Acme-Flow-Out-Dst-Port_FS1_F	Outbound destination (remote) port information for flow-set 1, forward direction.	24	integer	Start Interim-Update Stop
Acme-Flow-Out-Dst-Port_FS1_R	Outbound destination (remote) port information for flow-set 1, reverse direction.	89	integer	Start Interim-Update Stop
Acme-Flow-Out-Dst-Port_FS2_F	Outbound destination (remote) port information for flow-set 2, forward direction.	101	integer	Start Interim-Update Stop
Acme-Flow-Out-Dst-Port_FS2_R	Outbound destination (remote) port information for flow-set 2, reverse direction.	123	integer	Start Interim-Update Stop

---

This table lists and describes session attributes.

Attribute Name	Attribute Description	Attribute Value	Attribute Value Type	Messages
Acme-Session- Generic-Id	Common ID shared by H.323 and SIP call legs of a session. This attribute is a combination of a time stamp (measured in seconds) and a monotonically increasing 16-bit integer, followed by an at-sign (@) and the MAC address of the rear interface (wancom). This attribute is only used to correlate the H.323 and SIP legs of an interworking call/session. This VSA is not configurable; all CDRs contain this attribute.	40	string	Start Interim-Update Stop
Acme-Session- Ingress-CallId	Call ID generated by the originating device.	3	string	Start Interim-Update Stop
Acme-Session- Egress-CallId	Call ID generated by the SBC to represent a two-way transaction.	4	string	Start Interim-Update Stop
Acme-Session- Ingress-Realm	Explicitly identifies the ingress realm, and contains the name of the ingress realm for the session. All CDRs contain this attribute. This VSA is not configurable; all CDRs contain this attribute.	41	string	Start Interim-Update Stop



Attribute Name	Attribute Description	Attribute Value	Attribute Value Type	Messages
Acme-Session-Egress-Realm	Explicitly identifies the egress realm, and contains the name of the egress realm for the session. All CDRs contain this attribute. This VSA is not configurable. All CDRs contain this attribute, but it is only populated if an egress realm is found; a call without a route does not have an egress realm.	42	string	Start Interim-Update Stop
Acme-Session-Protocol-Type	Signaling protocol used for a particular leg of a session (in the case of IWF, there may be two legs). This attribute contains the signaling protocol type; for example, SIP or H323. This VSA is not configurable; all CDRs contain this attribute.	43	string	Start Interim-Update Stop
Acme-Session-Charging-Vector	Appears when the SBC inserts, passes, or deletes the P-Charging-Vector header (SIP). This attribute is only populated for SIP CDRs, and is not populated if the SBC does not have P-Charging-Vector information.	54	string	Start Interim-Update Stop

Attribute Name	Attribute Description	Attribute Value	Attribute Value Type	Messages
Acme-Session-Charging-Function_Address	Appears when the SBC inserts, passes, or deletes the P-Charging-Function-Address. This attribute is only populated for SIP CDRs, and is not populated if the SBC does not have P-Charging-Function-Address information.	55	string	Start Interim-Update Stop
Acme-Session-Disposition	Status of the call attempt as it progresses from being initiated (using a SIP INVITE or H.323 Setup message) to being either answered or failing to be answered.	60	integer	Start Interim-Update Stop
Acme-Post-Dial-Delay	Amount of time between session initiation and an alerting event.	58	integer	Start Interim-Update Stop
Acme-P-Asserted-ID	P-Asserted ID as described in RFC 3325.	69	string	Start Interim-Update Stop
Acme-SIP-Diversion	SIP Diversion header; communicates to the called party from whom and why a call diverted.	70	string	Start Interim-Update Stop
Acme-Primary-Routing-Number	Primary routing number and phone context (or ingress SIP Request-URI).	64	string	Start Interim-Update Stop
Acme-Egress-Final-Routing-Number	Final routing number and phone context (or egress SIP Request-URI).	134	integer	Stop
Acme-Disconnect-Initiator	Initiator of a call disconnect.	61	integer	Stop
Acme-Disconnect-Cause	Q.850 cause code value.	62	integer	Stop
Acme-SIP-Status	SIP status code for RFC 3326 support.	71	integer	Stop
Acme-Originating-Trunk-Group	Originating trunk group.	65	string	Start Interim-Update Stop

Attribute Name	Attribute Description	Attribute Value	Attribute Value Type	Messages
Acme-Originating-Trunk-Context	Originating trunk group context.	67	string	Start Interim-Update Stop
Acme-Terminating-Trunk-Group	Terminating trunk group.	66	string	Start Interim-Update Stop
Acme-Terminating-Trunk-Context	Terminating trunk group context.	68	string	Start Interim-Update Stop
Acme-Ingress-Local-Addr	Signaling IP address and port of the ingress SBC signaling interface.	74	string	Start Interim-Update Stop
Acme-Ingress-Remote-Addr	Signaling IP address and port of the ingress remote signaling element.	75	string	Start Interim-Update Stop
Acme-Egress-Local-Addr	Signaling IP address and port of the egress SBC signaling interface.	76	string	Start Interim-Update Stop
Acme-Egress-Remote-Addr	Signaling IP address and port of the destination signaling element.	77	string	Start Interim-Update Stop
Acme-Session-Ingress-RPH	RPH value received in the incoming call (e.g., ets.1). Only populated for NSEP calls.	135	string	Start Interim-Update Stop
Acme-Session-Egress-RPH	RPH value sent in the outgoing call (e.g., ets.3). Only populated for NSEP calls.	136	string	Start Interim-Update Stop
Acme-Ingress-Network-Interface-Id	To differentiate overlapping IP address spaces (with the Acme-Ingress-Vlan-Tag-Value), gives the ID of the ingress network interface.	137	string	Start Interim-Update Stop
Acme-Ingress-Vlan-Tag-Value	To differentiate overlapping IP address spaces (with the Acme-Ingress-Network-Interface-Id), gives the VLAN tag.	138	integer	Start Interim-Update Stop

Attribute Name	Attribute Description	Attribute Value	Attribute Value Type	Messages
Acme-Egress-Network-Interface-Id	To differentiate overlapping IP address spaces (with the Acme-Egress-Vlan-Tag-Value), gives the ID of the ingress network interface.	139	string	Start Interim-Update Stop
Acme-Egress-Vlan-Tag-Value	To differentiate overlapping IP address spaces (with the Acme-Egress-Network-Interface-Id), gives the VLAN tag.	140	integer	Start Interim-Update Stop
Acme-Refer-Call-Transfer-Id	For SIP REFER call method transfer, communicates a call has been transferred from the referer to the referree	141	string	Stop

This table lists and describes QoS attributes.

Attribute Name	Attribute Description	Attribute Value	Attribute Value Type	Messages
Acme-Calling-RTCP-Packets-Lost_FS1	Total lost packets reported via Real-time Transport Protocol Control Protocol (RTCP), flow-set 1. Populated only if QoS is enabled.	32	integer	Stop
Acme-Calling-RTCP-Packets-Lost_FS2	Total lost packets reported via Real-time Transport Protocol Control Protocol (RTCP), flow-set 2. Populated only if QoS is enabled.	104	integer	Stop
Acme-Calling-RTCP-Avg-Jitter_FS1	Average jitter reported via RTCP measured in milliseconds, flow-set 1. Populated only if QoS is enabled.	33	integer	Stop

Attribute Name	Attribute Description	Attribute Value	Attribute Value Type	Messages
Acme-Calling-RTCP-Avg-Jitter_FS2	Average jitter reported via RTCP measured in milliseconds, flow-set 2. Populated only if QoS is enabled.	105	integer	Stop
Acme-Calling-RTCP-Avg Latency_FS1	Average latency reported by comparing the timestamps in RTCP packets for each direction of a call, flow-set 1. Populated only if QoS is enabled.	34	integer	Stop
Acme-Calling-RTCP-Avg Latency_FS2	Average latency reported by comparing the timestamps in RTCP packets for each direction of a call, flow-set 2. Populated only if QoS is enabled.	106	integer	Stop
Acme-Calling-RTCP-MaxJitter_FS1	Maximum amount of jitter value reported via RTCP measured in milliseconds, flow-set 1. Populated only if QoS is enabled.	35	integer	Stop
Acme-Calling-RTCP-MaxJitter_FS2	Maximum amount of jitter value reported via RTCP measured in milliseconds, flow-set 3. Populated only if QoS is enabled.	107	integer	Stop
Acme-Calling-RTCP-MaxLatency_FS1	Maximum latency value measured in milliseconds as observed through RTCP, flow-set 1. Populated only if QoS is enabled.	36	integer	Stop

Attribute Name	Attribute Description	Attribute Value	Attribute Value Type	Messages
Acme-Calling-RTCP-MaxLatency_FS2	Maximum latency value measured in milliseconds as observed through RTCP, flow-set 2. Populated only if QoS is enabled.	108	integer	Stop
Acme-Calling-Octets_FS1	Bytes of RTP traffic for this call, flow-set 1. Populated only if QoS is enabled.	28	integer	Stop
Acme-Calling-Octets_FS2	Bytes of RTP traffic for this call, flow-set 2. Populated only if QoS is enabled.	102	integer	Stop
Acme-Calling-Packets_FS1	Number of RTP Packets, received by the SBC, from the calling party, for flow-set 1. Populated only if QoS is enabled.	29	integer	Stop
Acme-Calling-Packets_FS2	Number of RTP Packets, received by the SBC, from the calling party, for flow-set 2. Populated only if QoS is enabled.	103	integer	Stop
Acme-Calling-RTP-Packets-Lost_FS1	Total RTP packets lost in flow-set 1. Populated only if QoS is enabled.	37	integer	Stop
Acme-Calling-RTP-Packets-Lost_FS2	Total RTP packets lost in flow-set 2. Populated only if QoS is enabled.	109	integer	Stop
Acme-Calling-RTP-Avg-Jitter_FS1	Total jitter measured on RTP packets in milliseconds, flow-set 1. Populated only if QoS is enabled.	38	integer	Stop
Acme-Calling-RTP-Avg-Jitter_FS2	Total jitter measured on RTP packets in milliseconds, flow-set 2. Populated only if QoS is enabled.	110	integer	Stop

Attribute Name	Attribute Description	Attribute Value	Attribute Value Type	Messages
Acme-Calling-RTP- MaxJitter_FS1	Maximum jitter measured on RTP packets in milliseconds, flow-set 1. Populated only if QoS is enabled.	39	integer	Stop
Acme-Calling-RTP- Avg- MaxJitter_FS2	Maximum jitter measured on RTP packets in milliseconds, flow-set 2. Populated only if QoS is enabled.	111	integer	Stop
Acme-Called- Octets_FS1	Number of Octets (8 bits) of RTP traffic, received by the SBC, from the called party, for flow-set 1. Populated only if QoS is enabled.	44	integer	Stop
Acme-Called- Octets_FS2	Number of Octets (8 bits) of RTP traffic, received by the SBC, from the called party, for flow-set 2. Populated only if QoS is enabled.	124	integer	Stop
Acme-Called- Packets_FS1	Number of RTP Packets, received by the SBC, from the called party, for flow-set 1. Populated only if QoS is enabled.	45	integer	Stop
Acme-Called- Packets_FS2	Number of RTP Packets, received by the SBC, from the called party, for flow-set 2. Populated only if QoS is enabled.	125	integer	Stop
Acme-Called- RTCP-Packets- Lost_FS1	Total lost packets reported via Real-time Transport Protocol Control Protocol (RTCP), flow-set 1. Populated only if QoS is enabled.	46	integer	Stop

Attribute Name	Attribute Description	Attribute Value	Attribute Value Type	Messages
Acme-Called-RTCP-Packets-Lost_FS2	Total lost packets reported via Real-time Transport Protocol Control Protocol (RTCP), flow-set 2. Populated only if QoS is enabled.	126	integer	Stop
Acme-Called-RTCP-Avg-Jitter_FS1	Average jitter reported via RTCP measured in milliseconds for the ingress side of the call, flow-set 1. Populated only if QoS is enabled.	47	integer	Stop
Acme-Called-RTCP-Avg-Jitter_FS2	Average jitter reported via RTCP measured in milliseconds for the ingress side of the call, flow-set 2. Populated only if QoS is enabled.	127	integer	Stop
Acme-Called-Avg-Latency_FS1	Average latency reported via RTCP measured in milliseconds for the ingress side of the call, flow-set 1. Populated only if QoS is enabled.	48	integer	Stop
Acme-Called-Avg-Latency_FS2	Average latency reported via RTCP measured in milliseconds for the ingress side of the call, flow-set 2. Populated only if QoS is enabled.	128	integer	Stop
Acme-Called-RTCP-MaxJitter_FS1	Maximum amount of jitter reported via RTCP measured in milliseconds for the ingress side of the call, flow-set 1. Populated only if QoS is enabled.	49	integer	Stop



Attribute Name	Attribute Description	Attribute Value	Attribute Value Type	Messages
Acme-Called-RTCP-MaxJitter_FS2	Maximum amount of jitter reported via RTCP measured in milliseconds for the ingress side of the call, flow-set 2. Populated only if QoS is enabled.	129	integer	Stop
Acme-Called-RTCP-MaxLatency_FS1	Maximum amount of latency reported via RTCP measured in milliseconds for the ingress side of the call, flow-set 1. Populated only if QoS is enabled.	50	integer	Stop
Acme-Called-RTCP-MaxLatency_FS2	Maximum amount of latency reported via RTCP measured in milliseconds for the ingress side of the call, flow-set 2. Populated only if QoS is enabled.	130	integer	Stop
Acme-Called-RTP-Packets-Lost_FS1	Total lost RTP packets for the ingress side of the call, flow-set 1. Populated only if QoS is enabled.	51	integer	Stop
Acme-Called-RTP-Packets-Lost_FS2	Total lost RTP packets for the ingress side of the call, flow-set 2. Populated only if QoS is enabled.	131	integer	Stop
Acme-Called-RTP-Avg-Jitter_FS1	Average jitter reported via RTP measured in milliseconds for the ingress side of the realm, flow-set 1. Populated only if QoS is enabled.	52	integer	Stop
Acme-Called-RTP-Avg-Jitter_FS2	Average jitter reported via RTP measured in milliseconds for the ingress side of the realm, flow-set 2. Populated only if QoS is enabled.	132	integer	Stop

Attribute Name	Attribute Description	Attribute Value	Attribute Value Type	Messages
Acme-Called-RTP-MaxJitter_FS1	Maximum amount of jitter reported via RTP measured in milliseconds for the ingress side of the call, flow-set1. Populated only if QoS is enabled.	53	integer	Stop
Acme-Called-RTP-MaxJitter_FS2	Maximum amount of jitter reported via RTP measured in milliseconds for the ingress side of the call, flow-set 2. Populated only if QoS is enabled.	133	integer	Stop
Acme-Calling-R-Factor	QoS R-Factor calculation for the calling side of a session. Populated only if QoS is enabled. This value is reported as * 100 in order to appear as an integer.	151	integer	Stop
Acme-Calling-MOS	QoS MOS calculation for the calling side of a session. Populated only if QoS is enabled. This value is reported as * 100 in order to appear as an integer.	152	integer	Stop
Acme-Called-R-Factor	QoS R-Factor calculation for the called side of a session. Populated only if QoS is enabled. This value is reported as * 100 in order to appear as an integer.	153	integer	Stop

Attribute Name	Attribute Description	Attribute Value	Attribute Value Type	Messages
Acme-Called-MOS New in Release	QoS MOS calculation for the called side of a session. Populated only if QoS is enabled. This value is reported as * 100 in order to appear as an integer.	154	integer	Stop
Acme-Session-Forked-Call-Id	The VSA is a string value, and appears as the header-value without the header parameters from the P-Multiring-Correlator header for a session identified as part of a forked call.	171	string	Stop
Acme-Flow-Calling-Media-Stop-Time_FS1	calling side's media stop time - stream 1	231	string	Start Interim-Update Interim-Update (error) Stop
Acme-Flow-Called-Media-Stop-Time_FS1	called side's media stop time - stream 1	232	string	Start Interim-Update Interim-Update (error) Stop
Acme-Flow-Calling-Media-Stop-Time_FS2	calling side's media stop time - stream 2	233	string	Start Interim-Update Interim-Update (error) Stop
Acme-Flow-Called-Media-Stop-Time_FS2	called side's media stop time - stream 2	234	string	Start Interim-Update Interim-Update (error) Stop

## IPv6 Support

The following table lists the media flow attributes for IPv6 flows.

Attribute Name	Attribute Description	Attribute Value	Attribute Value Type	Messages
Acme-Flow-In-Src-IPv6_Addr_FS1_F	Inbound source IPv6 address (remote) information for flow-set 1, forward direction.	155	ipv6addr	Start Interim-Update Stop
Acme-Flow-In-Dst-IPv6_Addr_FS1_F	Inbound destination (local) address information (the IPv6 address field value of the steering pool configuration) for flow-set 1, forward direction.	156	ipv6addr	Start Interim-Update Stop
Acme-Flow-Out-Src-IPv6_Addr_FS1_F	Outbound source (local) address information (the IPv6 address field value of the steering port configuration) for flow-set 1, forward direction.	157	ipv6addr	Start Interim-Update Stop
Acme-Flow-Out-Dst-IPv6_Addr_FS1_F	Outbound destination (remote) IPv6 address information for flow-set 1, forward direction.	158	ipv6addr	Start Interim-Update Stop
Acme-Flow-In-Src-IPv6_Addr_FS1_R	Inbound source IPv6 address (remote) information for flow-set 1, reverse direction.	159	ipv6addr	Start Interim-Update Stop
Acme-Flow-In-Dst-IPv6_Addr_FS1_R	Inbound destination (local) address information (the IPv6 address field value of the steering pool configuration) for flow-set 1, reverse direction.	160	ipv6addr	Start Interim-Update Stop
Acme-Flow-Out-Src-IPv6_Addr_FS1_R	Outbound source (local) address information (the IPv6 address field value of the steering port configuration) for flow-set 1, reverse direction.	161	ipv6addr	Start Interim-Update Stop
Acme-Flow-Out-Dst-IPv6_Addr_FS1_R	Outbound destination (remote) IPv6 address information for flow-set 1, reverse direction.	162	ipv6addr	Start Interim-Update Stop
Acme-Flow-In-Src-IPv6_Addr_FS2_F	Inbound source address (remote) IPv6 information for flow-set 2, forward direction.	163	ipv6addr	Start Interim-Update Stop
Acme-Flow-In-Dst-IPv6_Addr_FS2_F	Inbound destination (local) address information (the IPv6 address field value of the steering pool configuration) for flow-set 2, forward direction.	164	ipv6addr	Start Interim-Update Stop
Acme-Flow-Out-Src-IPv6_Addr_FS2_F	Outbound source (local) address information (the IPv6 address field value of the steering port configuration) for flow-set 2, forward direction.	165	ipv6addr	Start Interim-Update Stop
Acme-Flow-Out-Dst-IPv6_Addr_FS2_F	Outbound destination (remote) IPv6 address information for flow-set 2, forward direction.	166	ipv6addr	Start Interim-Update Stop

Attribute Name	Attribute Description	Attribute Value	Attribute Value Type	Messages
Acme-Flow-In-Src-IPv6_Addr_FS2_R	Inbound source address (remote) IPv6 address information for flow-set 2, reverse direction.	167	ipv6addr	Start Interim-Update Stop
Acme-Flow-In-Dst-IPv6_Addr_FS2_R	Inbound destination (local) address information (the IPv6 address field value of the steering pool configuration) for flow-set 2, reverse direction.	168	ipv6addr	Start Interim-Update Stop
Acme-Flow-Out-Src-IPv6_Addr_FS2_R	Outbound source (local) address information (the IPv6 address field value of the steering port configuration) for flow-set 2, reverse direction.	169	ipv6addr	Start Interim-Update Stop
Acme-Flow-Out-Dst-IPv6_Addr_FS2_R	Outbound destination (remote) IPv6 address information for flow-set 2, reverse direction.	170	ipv6addr	Start Interim-Update Stop
Acme-Flow-Calling-Media-Stop-Time_FS1	calling side's media stop time - stream 1	231	string	Start Interim-Update Interim-Update (error) Stop
Acme-Flow-Called-Media-Stop-Time_FS1	called side's media stop time - stream 1	232	string	Start Interim-Update Interim-Update (error) Stop
Acme-Flow-Calling-Media-Stop-Time_FS2	calling side's media stop time - stream 2	233	string	Start Interim-Update Interim-Update (error) Stop
Acme-Flow-Called-Media-Stop-Time_FS2	called side's media stop time - stream 2	234	string	Start Interim-Update Interim-Update (error) Stop

## Oracle VSA Values

The table below defines the possible values for several Oracle VSAs.

Oracle VSA Name	Attribute Value	Possible Values
Acme-PostDial-Delay	58	Unit value in milliseconds

Oracle VSA Name	Attribute Value	Possible Values
Acme-Session-Disposition	60	0=unknown 1=call_attempt 2=ringing 3=answered
Acme-Disconnect-Initiator	61	0=UNKNOWN_DISCONNECT_INITIATOR 1=CALLING_PARTY_DISCONNECT 2=CALLED_PARTY_DISCONNECT 3=INTERNAL_DISCONNECT
Acme-Disconnect-Cause	62	34=No circuit/channel available 47=Resource unavailable 3=No route destination 31=Normal, unspecified 88=Incompatible destination 111=Interworking, unspecified 38=Network out of order 42=Switching equip congestion 28=Invalid number format 41=Temporary failure 17=User busy 16=Normal call clearing 20=Subscriber absent 31=Normal call clearing 18=Request error timeout response 55=Forbidden error response 0=No reason cause presented
Acme-SIP-Diversion	70	SIP Diversion header based on this RFC draft: draft-levy-sip-diversion-05.txt

Oracle VSA Name	Attribute Value	Possible Values
Acme-SIP-Status	71	This is a complete list of support status codes; only a subset would be reported in a Stop record: RESP_STATUS_TRYING 100 RESP_STATUS_RINGING 180 RESP_STATUS_FORWARD 181 RESP_STATUS_QUEUED 182 RESP_STATUS_PROGRESS 183 RESP_STATUS_OK 200 RESP_STATUS_CREATED 201 RESP_STATUS_ACCEPTED 202 RESP_STATUS_PART 206 RESP_STATUS_MAX_OK 299 RESP_STATUS_MULTIPLE 300 RESP_STATUS_MOVED 301 RESP_STATUS_MOVED_TMP 302 RESP_STATUS_USE_PROXY 305 RESP_STATUS_ALTERNATE 380 RESP_STATUS_BAD 400 RESP_STATUS_UNAUTH 401 RESP_STATUS_PAY_REQ 402 RESP_STATUS_FORBIDDEN 403 RESP_STATUS_NOT_FOUND 404 RESP_STATUS_NOT_ALLOW 405 RESP_STATUS_NOT_ACCEPT 406 RESP_STATUS_AUTH_REQ 407 RESP_STATUS_REQ_TMO 408 RESP_STATUS_CONFLICT 409 RESP_STATUS_GONE 410 RESP_STATUS_LEN_REQ 411 RESP_STATUS_TOO_BIG 413 RESP_STATUS_URI_TOO_BIG 414 RESP_STATUS_MEDIA 415 RESP_STATUS_URI_SCHEME 416 RESP_STATUS_BAD_EXT 420 RESP_STATUS_EXT_REQ 421 RESP_STATUS_TOO_SMALL 422 RESP_STATUS_TOO_BRIEF 423 RESP_STATUS_TMP_UNAVAIL 480 RESP_STATUS_NO_EXIST 481 RESP_STATUS_LOOP 482 RESP_STATUS_TOOMNY_HOPS 483 RESP_STATUS_ADDR_INCMPL 484 RESP_STATUS_AMBIGUOUS 485 RESP_STATUS_BUSY_HERE 486 RESP_STATUS_CANCELLED 487 RESP_STATUS_NOT_HERE 488

Oracle VSA Name	Attribute Value	Possible Values
		RESP_STATUS_BAD_EVENT 489
		RESP_STATUS_PENDING 491
		RESP_STATUS_UNDECIPH 493
		RESP_STATUS_INT_ERR 500
		RESP_STATUS_NOT_IMPL 501
		RESP_STATUS_BAD_GTWY 502
		RESP_STATUS_SVC_UNAVAIL 503
		RESP_STATUS_GTWY_TMO 504
		RESP_STATUS_BAD_VER 505
		RESP_STATUS_MSG_TOO_BIG 513
		RESP_STATUS_PRE_FAIL 580
		RESP_STATUS_BUSY 600
		RESP_STATUS_DECLINE 603
		RESP_STATUS_DONT_EXIST 604
		RESP_STATUS_NOTACCEPT 606

## Authentication VSAs

The table below defines Oracle VSAs used for RADIUS authentication.

Oracle VSA Name	Attribute Value	Attribute Values
Acme-User-Privilege	Describes at RADIUS login the privileges granted to the administrator (VSA only available with admin security license installed). Values can be: sftpForAudit (SFTP is allowed for audit logs) sftpForAll (SFTP is allowed for logging, and audit logs)	253
Acme-User-Class	Identifies the authorization class on the SBC; used for RADIUS authentication only and does not apply to accounting. Values can be user or admin	254

## RTP Traffic Reporting per Call

The SBC reports total RTP traffic counts, both received and transmitted for calls through standard accounting interfaces on stop record generation. This traffic is reported in Packets and Octets, sent and received, for flow-sets 1 and 2. The QoS feature set must be enabled to report on RTP traffic, otherwise the values will be reported as 0

These statics are captured for the following scenarios

- RTP pass-thru sessions
- transcoded/transrated/inband (audio) DTMF-interworked RTP sessions
- RTP sessions where one or both call legs is encrypted (SRTP)



RTP traffic reporting does not capture MSRP B2BUA and MSRP NAT traffic.

The quick way to decipher these 16 statistics are as follows:

- Calling/Called - call-leg the static reports on
- Octets/Packets - counter unit for traffic
- FS1/FS2 - flow set 1 or flow set 2
- blank/transmitted - traffic received (blank) or transmitted by the SBC

Counter Definition	RADIUS/Local CDR (VSA #) output	AVP in Acme-Packet- Specific-Rf-QoS(37)
Number of Octets (8 bits) of RTP traffic, received by the SBC, from the calling party, for flow-set 1	Acme-Calling-Octets-FS1 (28)	RTP-Calling-Octets-FS1 (38)
Number of RTP Packets, sent from the SBC, to the calling UA, for flow-set 1	Acme-Calling-Packets-FS1 (29)	RTP-Calling-Packets-FS1(40)
Number of Octets (8 bits) of RTP traffic, sent from the SBC, to the called UA, for flow-set 1	Acme-Called-Octets-FS1 (44)	RTP-Called-Octets-FS1 (62)
Number of RTP Packets, sent from the SBC, to the called UA, for flow-set 1	Acme-Called-Packets-FS1 (45)	RTP-Called-Packets-FS1 (64)
Number of Octets (8 bits) of RTP traffic, received by the SBC, from the calling party, for flow-set 2	Acme-Calling-Octets-FS2 (102)	RTP-Calling-Octets-FS2 (39)
Number of RTP Packets, sent from the SBC, to the calling UA, for flow-set 2	Acme-Calling-Packets-FS2 (103)	RTP-Calling-Packets-FS2(41)
Number of Octets (8 bits) of RTP traffic, sent from the SBC, to the called UA, for flow-set 2	Acme-Called-Octets-FS2 (124)	RTP-Called-Octets-FS2 (63)
Number of RTP Packets, sent from the SBC, to the called UA, for flow-set 2	Acme-Called-Packets-FS2 (125)	RTP-Called-Packets-FS2 (65)
Number of Octets (8 bits) of RTP traffic, transmitted by the SBC, to the calling party, for flow-set 1	Acme-Calling-RTP-Octet-Transmitted-FS1 (240)	RTP-Calling-Octets-Transmitted-FS1 (42)
Number of RTP Packets, transmitted by the SBC, to the calling UA, for flow-set 1	Acme-Calling-RTP-Packets-Transmitted-FS1 (241)	RTP-Calling-Packets-Transmitted-FS1 (44)
Number of Octets (8 bits) of RTP traffic, transmitted by the SBC, to the called UA, for flow-set 1	Acme-Called-RTP-Octet-Transmitted-FS1 (242)	RTP-Called-Octets-Transmitted-FS1 (66)
Number of RTP Packets, transmitted by the SBC, to the called UA, for flow-set 1	Acme-Called-RTP-Packets-Transmitted-FS1 (243)	RTP-Called-Packets-Transmitted-FS1 (68)
Number of Octets (8 bits) of RTP traffic, transmitted by the SBC, to the calling party, for flow-set 2	Acme-Calling-RTP-Octets-Transmitted-FS2 (244)	RTP-Calling-Octets-Transmitted-FS2 (43)

Counter Definition	RADIUS/Local CDR (VSA #) output	AVP in Acme-Packet-Specific-Rf-QoS(37)
Number of RTP Packets, transmitted by the SBC, to the calling UA, for flow-set 2	Acme-Calling-RTP-Packets-Transmitted-FS2 (245)	RTP-Calling-Packets-Transmitted-FS1 (45)
Number of Octets (8 bits) of RTP traffic, transmitted by the SBC, to the called UA, for flow-set 2	Acme-Called-RTP-Octet-Transmitted-FS2 (246)	RTP-Called-Octets-Transmitted-FS2 (67)
Number of RTP Packets, transmitted by the SBC, to the called UA, for flow-set 2	Acme-Called-RTP-Packets-Transmitted-FS2 (247)	RTP-Called-Packets-Transmitted-FS2 (69)

## VoLTE and SMS VSAs

The SBC reports session-specific information for VoLTE calls and for Short Message Service (SMS) messages. Much of this information overlaps both session types as they address similar variables within their environments.

This table lists and describes the VoLTE and SMS attributes and includes attribute name, attribute description, attribute value, attribute value type, and messages.



### Note:

See the [Oracle RADIUS Acme-Extended-Attributes VSAs](#) section for an explanation of the attribute extensions included in the tables below.

Attribute Name	Attribute Description	Attribute Value	Attribute Value Type	Messages
Acme-Access-Network-Information	Extracted from Access-Network-Information field from P-Access-Network-Info headers. For MO calls it should be the PANI headers of the outgoing INVITE (after the NPLI procedure). For MT calls it should be the PANI headers of the outgoing 18x response (after the NPLI procedure).	248	SMS and VoLTE	Start Interim-Update Stop
Acme-P-GW IP Address	Obtained from PCRF RAR/AAA in Access-Network-Charging-Address (501) AVP.	249, ext 1	VoLTE call	Start Interim-Update Stop
Acme-S-GW IP Address	Obtained from PCRF AAA/RAR in AN-GW-Address (1050) AVP	249, ext 2	VoLTE call	Start Interim-Update Stop

Attribute Name	Attribute Description	Attribute Value	Attribute Value Type	Messages
Acme-Originating-IOI	Extracted from the Originating-IOI field in the P-Charging-Vector header. For MT, MO (MESSAGE/INVITE) calls, the field is extracted from SIP reply(20X).	249, ext 3	SMS and VoLTE call	Start Interim-Update Stop
Acme-Terminating-IOI	Extracted from the Terminating-IOI field in the P-Charging-Vector header. For MT, MO (MESSAGE/INVITE) calls, the field is extracted from SIP reply(20X).	249, ext 4	SMS and VoLTE call	Start Interim-Update Stop
Acme-IMEI	Extracted from the registration cache or Initial request. (The Initial request takes priority.)	249, ext 5	SMS and VoLTE call	Start Interim-Update Stop
Acme-Node-Functionality	Configured with a single, global Node Functionality value. This is done in the SIP config's node functionality parameter. However, if the node functionality parameter is also configured in a realm config, the ingress realm's node functionality value supersedes the global value.	249, ext 6	SMS and VoLTE call	Start Interim-Update Stop
Acme-SMS Message Type	Extracted from initial SIP MESSAGE.	249, ext 7	SMS	Stop
Acme-SMS Calling party number	Extracted from initial SIP MESSAGE. For MO, from the P-Asserted-Identity header For MT, from the TP-Originating-Address	249, ext 8	SMS	Stop
Acme-SMS Called party number	Extracted from initial SIP MESSAGE. For MO, from the TP-Destination-Address For MT, from the To header of the SIP MESSAGE	249, ext 9	SMS	Stop
Acme-Message Length	Extracted from SIP MESSAGE field TP-User-Data-Length	249, ext 10	SMS	Stop

Attribute Name	Attribute Description	Attribute Value	Attribute Value Type	Messages
Acme-History-Info	Extracted from History-Info sip headers, ingress interface and it taken from initial message. In case of multiple History-Info headers, concatenated into a single header values in CDR.	250	VoLTE call	Start Interim-Update Stop
Acme-Visited-Network-Identifier	Extracted from Visited-Network-Identifier field from P-Visited-Network-Id headers. For MO calls, the field is extracted from initial request, or from the ingress sip-interface if the PVNI is not received in the initial request. For MT calls, the field is extracted from the initial request.	251	SMS and VoLTE call	Start Interim-Update Stop
Acme-IMSI	Extracted from the registration cache or Initial request. (The Initial request takes priority.)	252	SMS and VoLTE call	Start Interim-Update Stop

This information appears in RADIUS CDRs, CSV CDRs, and the Oracle VSA dictionary. The SBC reports with AVP information that is equivalent to the VSA information below.

The SBC generates SMS call records when you configure the **generate-event** parameter with the **messages** value. Fields supporting message accounting include:

- Acme-Access-Network-Information (248)
- Acme-Visited-Network-Identifier (251)
- Acme-Originating-IOI (249, extension 3)
- Acme-Terminating-IOI (249, extension 4)
- Acme-IMSI (252)
- Acme-IMEI (249, extension 5)
- Acme-Node-Functionality (249, extension 6)
- Acme-SMS Message Type (249, extension 7)
- Acme-SMS Calling party number (249, extension 8)
- Acme-SMS Called party number (249, extension 9)
- Acme-Message Length (249, extension 10)
- Acme-Timestamp

The SBC generates VoLTE call records under the same scenarios and using the same configuration as other SIP calls. Fields supporting VoLTE call accounting include:

- Acme-Access-Network-Information (248)
- Acme-Visited-Network-Identifier (251)
- Acme-Originating-IOI (249, extension 3)
- Acme-Terminating-IOI (249, extension 4)
- Acme-IMSI (252)
- Acme-IMEI (249, extension 5)
- Acme-History-Info (250)
- Acme-Node-Functionality (249, extension 6)
- Acme-P-GW IP Address (249, extension 1)
- Acme-S-GW IP Address (249, extension 2)

 **Note:**

The SBC includes this same information within equivalent records managed over diameter. VSAs do not have the "Acme" prefix in their name, and the VSA identification information is specific to diameter VSAs.

## Distinct VoLTE Processes

For VoLTE calls, the process for generating CDRs is the largely the same as for other calls. As described, there are additional data points included for these call types.

In addition, the list below presents additional processes reserved for VoLTE data management with which you should be familiar:

- When there is an SRVCC event, the SBC creates a separate set of CDRs for the handover session. The SBC correlates the original and handover session using the "Generic-ID" field, which points to the Call-ID of the initial session. In addition, the SBC populates the Generic-ID field within the Initial Session CDRs (STOP), with the HO session Call-ID.
- The SBC copies the Call id of the second INVITE (Handover INVITE) into the Generic Id into the CDR for the first INVITE (initial call) for both MO and MT call
  - For mobile originating call—When the SBC receives the 200 Ok for the BYE from UE, it inserts the Call id of second INVITE, which is generated from the MSC-S as Generic Id, into the CDR of First MO Invite (Before the handover call).
  - For mobile terminating call—When the SBC receives the 200 Ok for the BYE from UE, it inserts the Call id of the second INVITE, which is generated from the MSC-S as Generic Id, into the CDR of the first MT INVITE (before the handover call).
  - If there is a negative case, such as a BYE timeout, the SBC writes the Call id of second INVITE, which is generated from the MSC-S as the Generic Id, into the CDR of the first INVITE (before the handover call) when that corresponding call gets terminated.

 **Note:**

The SBC performs these same processes for both RADIUS accounting when generating CDRs and Diameter accounting when generating ACRs.

## Configurations to Specify VoLTE and SMS Data

You can configure the SBC to use specific data in call data records provided over RADIUS, Diameter and within local CSVs. This ensures that the specified fields

There are two configurations available for specifying VoLTE and SMS data:

- Subscribe to IP-CAN-CHANGE events
- Specify Inter-Operator Identifier (IOI)

### Subscribe to IP-CAN-CHANGE Events

You can configure a subscription to the IP-CAN-CHANGE event using the Rx interface during the AAA/RAR exchange. To do this, you configure the **ip-can-change** value to the **specific-action-subscription** of the applicable **ext-policy-config**. This causes the SBC to apply the value in the AN-GW-Address AVP from the PCRF as the S-GW IP address.

 **Note:**

If the SBC receives more than one AN-GW-Address AVP from the PCRF, it applies the value in the AN-GW-Address AVP from the PCRF. It also uses the S-GW IP address the first AVP as the S-GW IP address.

### Option to Specify IOI

You configure the **realm-as-ioi** option in the applicable **account-config** to send the realm name as the IOI in diameter ACRs. If this option is not set, the SBC uses the IOI from the charging vector.

Configure this option using the syntax below.

```
ORACLE (account-config) # options +realm-as-ioi
```

If you type options and then the option value without the plus sign, you overwrite any previously configured options. To add a new option to an options list, pre-pend the new option with a plus sign as shown in the previous example.

## Configuring the ip-can-change Subscription

You use the steps below to Subscribe to IP-CAN-CHANGE events at the PCRF and apply the value in the AN-GW-Address AVP from the PCRF as the S-GW IP address.

To obtain the S-GW IP address for mobile originating and terminating scenarios and provide that data in CDRs for RADIUS, diameter and local CSVs:

1. In Superuser mode, type **configure terminal** and press Enter.

```
ORACLE# configure terminal
```

2. Type **media-manager** and press Enter.

```
ORACLE (configure) # media-manager
```

3. Type **ext-policy-config** and press Enter.

```
ORACLE (session-router) # ext-policy-config  
ORACLE (ext-policy-config) #
```

4. Type **specific-action-subscription ip-can-change** and press Enter.

```
ORACLE (session-router) # specific-action-subscription ip-can-change  
ORACLE (ext-policy-config) #
```

The **specific-action-subscription** accepts multiple values. When configuring 2 or more specific actions, enclose them in quotation marks, with the values separated by spaces.

5. Save your work.

## Including P-Visited Network Identifier and History-Info Headers in CDRs

You can configure the SBC to add fully compliant P-Visited Network Identifier (PVNI) and History-Info (HI) headers in CDRs. You configure this by adding the **pcscf-cdr-compliance** option to the **account-config**, specifying whether you want to include PVNI (**PVNI-pref**), HI (**HI-pref**), or both. The behavior is dependent on the type of call, including Mobile Terminating (MT) and Mobile Originating (MO), information provided by SIP, and whether you are also using an S8HR profile.

The PVNI and HI fields in CDRs may or may not contain data. When configured, the SBC performs processes to determine whether or not to add:

- P-Visited-Network-ID to the applicable CDR field
- History-Info to the applicable CDR field

You configure the **pcscf-cdr-compliance** in the applicable **account-config** to use these processes within your environment.

```
ORACLE# configure terminal  
ORACLE (configure) # session-router  
ORACLE (session-router) # account-config  
ORACLE (account-config) # select  
ORACLE (account-config) # options +pcscf-cdr-compliance=PVNI-pref
```

If you save and activate this configuration, the SBC enables PVNI CDR population for MT calls. To configure for both PVNI and HI headers, configure the option with both values separated by a comma and enclosed in quotes.

```
ORACLE(account-config)# options +pcscf-cdr-compliance="PVNI-pref,HI-pref"
```

### Support for P-Visited-Network-ID Field

For MT calls, the access SBC, deployed as an A-SBC, inserts the PVNI header in CDRs based on the called party registration cache entry (MCC/MNC). If the Called party registration cache does not have a PVNI value, the A-SBC inserts the **network-id** value from the access side (egress realm) **sip-interface** configuration as the PVNI into CDRs.

For both MO and MT and when you configure it to add PVNI to CDRs, the A-SBC checks for an **s8hr-profile** in the same interface:

- If there is an S8HR profile on the access **sip-interface**:
  - If the SBC receives an MCC/MNC from the Rx server, it creates the PVNI header using the called party registration cache entry (MCC/MNC) and adds it to the CDR.
  - If the SBC does not receive an MCC/MNC, It checks whether there is a **network-id** value on the access side **sip-interface**:
    1. If so, the SBC creates the PVNI using that **network-id** value.
    2. If not, the SBC uses the **local-mccmnc** value as the PVNI, and adds it to CDR.

#### Note:

If you have not configured the **local-mccmnc** value in your S8HR profile, the SBC uses the default, which is 999999.

- If there is not an S8HR profile on the access **sip-interface**, the SBC checks whether there is a **network-id** value on the access side **sip-interface**. If so, the SBC uses the **network-id** value as the PVNI, and adds it to CDR.
- If both the S8HR and the egress (access) **network-id** are not configured, the SBC checks whether the initial INVITE/MESSAGE comes from a trusted endpoint and contains a PVNI:
  - If so, the SBC relays the PVNI and add to CDR.
  - If not, the SBC leaves the PVNI field empty.

When you have set the **pcscf-cdr-compliance** option to include PVNI, and the SBC is acting as an I-SBC handling MO/MT calls, the SBC uses the following sequence for populating the CDR field:

1. If configured, uses the **network-id** on the ingress **sip-interface** as PVNI.
2. If populated and from a trusted endpoint, uses the PVNI from the initial INVITE.
3. Leaves the PVNI field empty.

#### Note:

This behavior applies to the INVITE or any Re-INVITE.



## Support for History-Info Field

For MO calls, if you have configured the HI option in the **account-config**, SBC uses the History-Info(s) received in the initial INVITE replies, including those with 181, 180 or 200 status-codes. The SBC populates the CDR with the last provisional (>100) or final (200) response containing History-Info(s). If History-Info is not available in provisional or final replies, the SBC leaves the History-Info in the CDR empty.

For MT calls, SBC extracts History-Info header(s) from the initial INVITE and adds them to the CDR. If History-Info is not available in the initial INVITE, the SBC leaves the HI field empty.

If there are multiple History-Info headers in the initial INVITE, the SBC concatenates all the history-info headers values, and without exceeding the default or configured CDR field size, adds them to the CDR.

For example, assume INVITE has three History-Info headers in the following order:

1. HI-1 - 100 characters
2. HI-2 - 100 characters
3. HI-3 - 100 characters

By default, the maximum CDR field size is 246. In this case, the SBC includes the first two History-Info headers in their entirety, and truncates HI-3.

Consider the presence of the following HI headers:

- History-Info: <sip:bob@example.com>;index=1
- History-Info: <sip:office@example.com>;index=1.2;mp=1
- History-Info: <sip:office@192.0.2.5>;index=1.2.1;rc=1.2

The SBC populates the History-Info CDR as follows

```
<sip:bob@example.com>;index=1,  
<sip:office@example.com>;index=1.2;mp=1, <sip:office@192.0.2.5>;index=  
1.2.1;rc=1.2
```

## P-Asserted-ID Header Format in CDRs

The P-Asserted-ID (PAI) Header URI in CDR displays without the display name by default, even though PAI header is present along with the display-name in the SIP message. The format includes <> (angle brackets) symbol in the Acme-P-Asserted-ID. For example, Acme-P-Asserted-ID = <sip:office@example.com>. To include angle brackets symbol in the Acme-P-Asserted-ID, add an option **display-name-AVP-add** under **account-config**, so that PAI header URI in CDR, displays along with the display-name if present.

### Adding the display-name-AVP-add option

To add an option **display-name-AVP-add** under **account-config** from CLI:

```
ORACLE# configure terminal  
ORACLE(configure)# session-router
```

```
ORACLE(session-router)# account-config
ORACLE(account-config)# options +display-name-AVP-add
```

If you type the option without the plus sign, you overwrite any previously configured options. To append the new option to the options list, prepend the new option with a plus sign as shown in the previous example.

## Oracle RADIUS Acme-Extended-Attributes VSAs

As new attributes become available in the RADIUS dictionary, they are accessible on the Acme-Extended-Attributes attribute. These statistics are also available in local CSVs.

### MSRP Attributes

MSRP attributes will look like the following when put on one AVP:

```
msrp-attr-type = 0
msrp-attr-len = ...
msrp-attr-data = {1, Acme-MSRP-Calling-Packets, Acme-MSRP-Calling-Octets,
Acme-MSRP-Calling-Packets-Transmitted, Acme-MSRP-Calling-Octets-Transmitted,
Acme-MSRP-Called-Packets, Acme-MSRP-Called-Octets, Acme-MSRP-Called-Packets-
transmitted, Acme-MSRP-Called-Octets-Transmitted}
```

For example, if the value for a call is `is0x00230100000001000000f6000000010000009a000000010000009a00000001000000f5`, you should create a parser to break up the information as follows:

- Type: 0x00
- Length: 23
- Version: 01
- Calling Packets: 00000001
- Calling Octets: 000000f6
- Calling Packets Transferred: 00000001
- Calling Octets Transferred: 0000009a
- Called Octets: 0000009a
- Called Packets Transferred: 00000001
- Called Octets Transferred: 000000f5

**Table 5-1 MSRP Attributes in CDRs**

Attribute Name	Attribute Description	Attribute Value	Attribute Value Type	Messages
Acme-MSRP-Calling-Packets-Received	MSRP total calling (initiating side) packets received by the SBC	249, extended	integer	Stop

**Table 5-1 (Cont.) MSRP Attributes in CDRs**

Attribute Name	Attribute Description	Attribute Value	Attribute Value Type	Messages
Acme-MSRP-Calling-Octets-Received	MSRP total calling (initiating side) octets received by the SBC	249, extended	integer	Stop
Acme-MSRP-Calling-Packets-Transmitted	MSRP total calling (initiating side) transmitted packets by the SBC	249, extended	integer	Stop
Acme-MSRP-Calling-Octets-Transmitted	MSRP total calling (initiating side) transmitted octets by the SBC	249, extended	integer	Stop
Acme-MSRP-Called-Packets-Received	MSRP total called (answering side) received packets by the SBC	249, extended	integer	Stop
Acme-MSRP-Called-Octets-Received	MSRP total called (answering side) octets received by the SBC	249, extended	integer	Stop
Acme-MSRP-Called-Packets-Transmitted	MSRP total called (answering side) transmitted packets by the SBC	249, extended	integer	Stop
Acme-MSRP-Called-Octets-Transmitted	MSRP total called (answering side) transmitted octets by the SBC	249, extended	integer	Stop

## STIR/SHAKEN Attributes

This table lists and describes the STIR/SHAKEN attributes used for RADIUS CDRs. The table includes attribute name, attribute description, attribute value, attribute value type, and the list of CDR message types for which the value is captured.

Attribute Name	Attribute Description	Attribute Value	Attribute Value Type	Messages
Acme-Stir-Signed-Request	<p>This AVP indicates that the SBC has sent the signing request to the STI-AS and received a response.</p> <p>Values for this AVP mean:</p> <ul style="list-style-type: none"> <li>• 1— The SBC has signed the INVITE.</li> <li>• 0—The SBC has not signed the INVITE.</li> <li>• 2—Signing is not applicable for the INVITE.</li> </ul>	249, extension 11	String	START INTERIM STOP

Attribute Name	Attribute Description	Attribute Value	Attribute Value Type	Messages
Acme-Stir-Signed-Request-Exception-Id	This AVP indicates that the SBC did not sign the INVITE because of a failure response from the STI-AS. It includes the ATIS defined service and policy exception id (e.g. SVC4000, SVC4001, POL4050). Potential values are in the table below.	249, extension 12	String	START INTERIM STOP
Acme-Stir-Verification-Request	This AVP indicates that the SBC has sent the verification request to the STI-VS and received a response. Values for this AVP mean: <ul style="list-style-type: none"> <li>• 1— The SBC has verified the request.</li> <li>• 0—The SBC has not signed verified the request.</li> <li>• 2—Request verification is not applicable for the call.</li> </ul>	249, extension 13	String	START INTERIM STOP
Acme-Stir-Verification-Request-Exception-Id	This AVP indicates that the SBC did not verify the request because of a failure response from the STI-VS. It includes the ATIS defined service and policy exception id (e.g. SVC4000, SVC4001, POL4050). Potential values are in the table below.	249, extension 14	String	START INTERIM STOP
Stir-VS-Verstat	The SBC populates this AVP with the verstat values the SBC includes in the SIP INVITE following the Stir Shaken trigger. Potential values include TN-Validation-Passed, TN-Validation-Failed or No-TN-Validation	249, extension 15	String	START INTERIM STOP
Stir-VS-Reason	The SBC populates this AVP with received reason information.	249, extension 16	String	START INTERIM STOP

Attribute Name	Attribute Description	Attribute Value	Attribute Value Type	Messages
Stir-TN-Used-For-AS-VS-Request	<p>This AVP contains the TN number captured by the SBC. TN selection uses the following priority:</p> <ol style="list-style-type: none"> <li>1. From the Tel PAI (if present)</li> <li>2. From the SIP PAI (if present, and Tel PAI is not present)</li> <li>3. From the "From" header if both Tel and SIP PAI are not present.</li> </ol>	249, extension 17	String	START INTERIM STOP
Stir-Div-Signed-Request	<p>Upon sending the DIV signing request to the STI-AS and receiving a 200 OK successful response from STIR-AS, the SBC enumerates the results in this AVP as follows:</p> <ul style="list-style-type: none"> <li>• 1—indicates DIV signing the INVITE</li> <li>• 0—indicates no DIV signing the INVITE</li> <li>• 2—indicates DIV signing is not applicable on the INVITE</li> </ul>	249, extension 18	String	START INTERIM STOP
Stir-Div-Verified-Request	<p>Upon sending the DIV verify request to the STI-AS and receiving a 200 OK successful response from STIR-VS, the SBC enumerates the results in this AVP as follows:</p> <ul style="list-style-type: none"> <li>• 1—indicates DIV verification the INVITE</li> <li>• 0— indicates no DIV verification the INVITE</li> <li>• 2—indicates DIV verification is not applicable on the INVITE</li> </ul>	249, extension 19	String	START INTERIM STOP

STIR/SHAKEN attributes are embedded under one extended Radius AVP.

- type = 26 (vendor-specific)
- length = ...
- vendor-id = 9148 (acme)
- vendor-type = 249 (extended-attributes)
- vendor-length = ...

- vendor-data = { x-attr-type (16-bit), x-attr-len (16-bit), x-attr-data (variable) }

An example of an AVP presenting the Acme-Stir-Signed-Request attribute indicating the SBC has signed the INVITE appears as follows:

```
x-attr-type = 1 (Acme-Stir-Signed-Request) [1 byte]
x-attr-len = ... [1 byte]
x-attr-data = { version[1 byte], Acme-Stir-Signed-Request [depending on
length]}
```

### ATIS Defined Service and Policy Exception Codes

This table lists the potential ATIS defined service and policy exception codes that can be provided using the Stir-Signed-Request-Exception-Id or Stir-Verified-Request-Exception-Id AVP.

Exception ID	Exception Text	HTTP Status Code
SVC4000	Missing request body	400
SVC4001	Missing mandatory parameter '%1'	400
SVC4002	Requested response body type '%1' is not supported	406
SVC4003	Requested resource was not found	404
SVC4004	Unsupported request body type, expected '%1'	415
SVC4005	Invalid '%1' parameter value: %2	400
SVC4006	Failed to parse received message body: %1	400
SVC4007	Missing mandatory Content-Length header 411	411
POL4050	Method not allowed	405
POL5000	Internal Server Error. Please try again later	500

## Mappings and Disconnect Cause Values

This section provides information about H.323 and SIP disconnect cause values for RADIUS CDRs generated by the SBC.

### SIP H.323 and Q.850 Mappings

This section provides tables that show the mappings between SIP Status and: H.323 Disconnect Reason, H.323 Release Complete Reason, and RAS error. It also shows the mapping for Q.850 cause to H.323 Release Complete Reason.

#### SIP Status to H.323 Disconnect Reason Mapping

SIP Status	H.323 Disconnect Reason
480 Temporarily Unavailable	No Bandwidth

SIP Status	H.323 Disconnect Reason
404 Not Found	Gatekeeper Resource
404 Not Found	Unreachable Destination
603 Decline	Destination Rejection
505 Version Not Supported	Invalid Revision
401 Unauthorized	No Permission
503 Service Unavailable	Unreachable Gatekeeper
480 Temporarily Unavailable	Gateway Resource
400 Bad Request	Bad Format Request
486 Busy Here	Adaptive Busy
486 Busy Here	In Conference
500 Internal Server Error	Undefined Reason
486 Busy Here	Facility Call Deflection
401 Unauthorized	Security Denied

## SIP Status to H.323 RAS Error Mapping

SIP Status	H.323 RAS Error
404 Not Found	Gatekeeper Resource
401 Unauthorized	Invalid Permission
503 Service Unavailable	Request Denied
500 Internal Server Error	Undefined
401 Unauthorized	Caller Not Registered
305 User Proxy	Route Call to Gatekeeper
500 Internal Server Error	Invalid Endpoint ID
503 Service Unavailable	Resource Unavailable
401 Unauthorized	Security Denial
501 Not Implemented	QoS Control Not Supported
484 Address Incomplete	Incomplete Address
302 Moved Temporarily	Route Call to SCN
485 Ambiguous	Aliases Inconsistent
401 Unauthorized	Not Currently Registered

## SIP Status to H.323 Release Complete Reason Error Mapping

SIP Status	H.323 RAS Error
300 Multiple Choices	Undefined Reason
401 Unauthorized	Security Denied
402 Payment Required	Undefined Reason
403 Forbidden	No Permission
404 Not Found	Unreachable Destination
405 Method Not Allowed	Undefined Reason
606 Not Acceptable	Undefined Reason
407 Proxy Authentication Required	Security Denied
408 Request Timeout	Adaptive Busy

SIP Status	H.323 RAS Error
409 Conflict	Undefined Reason
410 Gone	Unreachable Destination
411 Length Required	Undefined Reason
414 Request-URI Too Large	Bad Format Address
415 Unsupported Media Type	Undefined Reason
420 Bad Extension	Bad Format Address
480 Temporarily Unavailable	Adaptive Busy
481 Call/Transaction Does Not Exist	Undefined Reason
482 Loop Detected	Undefined Reason
483 Too Many Hops	Undefined Reason
484 Address Incomplete	Bad Format Address

## Q.850 Cause to H.323 Release Complete Reason Mapping

The table below describes how the Q.850 Causes and the H.323 release complete reasons are mapped internally on the SBC.

Q.850 Cause	Numeric Code	H.323 Release Complete Reason
Not Route To Destination	3	Unreachable Destination
Normal Call Clearing	16	Destination Rejection
User Busy	17	In Conference
Subscriber Absent	20	Called Party Not Registered
Invalid Number Format	28	Bad Format Address
Normal Unspecified	16	Undefined Reason
No Circuit/Channel Available	34	No Bandwidth
Network Out of Order	38	Unreachable Gatekeeper
Temporary Failure	41	Adaptive Busy
Switching Equipment Congestion	42	Gateway Resource
Resource Unavailable	47	Gatekeeper Resource
Incompatible Destination	88	Invalid Revision
Interworking Unspecified	111	No Permission

## SIP-SIP Calls

The SBC maps SIP status codes and events to disconnect cause attribute values used by Cisco Systems Proxy Server (CSPS) accounting services.

SIP Status Category/Event	CDR Disconnect Cause	Description
Undetermined reason	0	Undetermined reason
BYE	1	Normal clearing
3xx: Redirection	2	Redirection
4xx: Client Error	3	Client error
5xx: Server Error	4	Server error
6xx: Global Failure	5	Global error



## SIP-H.323 Calls with Interworking

For calls that require SIP-H.323 interworking, the SBC generates two sets of RADIUS CDRs: one for the SIP call-leg and one for the H.323 call leg. The values recorded in RADIUS Stop records for the disconnect cause depend on the nature and source of the call disconnect or rejection.

## SIP Events and Errors

For calls rejected or disconnected because of SIP events and errors, the SBC records Q.850 cause values mapped from the SIP event/status code in the SIP CDR. For the H.323 CDR, the SIP status categories and events are mapped to Q.850 cause codes.

The entries in this table are determined by the [SIP Status to H.323 Release Complete Reason Error Mapping](#).

SIP Status Category/ Event	SIP CDR Disconnect Cause	H.323 Disconnect Cause Value (Q.850)
BYE	16—Normal call clearing	16—Normal call clearing
3xx	23—Redirection to new destination	16—Normal call clearing
404 Not Found	21—Call rejected	3—No route to destination
410 Gone	21—Call rejected	3—No route to destination
403 Forbidden	21—Call rejected	111—Interworking unspecified
408 Request Timeout	21—Call rejected	41—Temporary failure
413 Request Entity Too Big	21—Call rejected	28—Invalid number format
414 Request URI Too Large	21—Call rejected	28—Invalid number format
420 Bad Extension	21—Call rejected	28—Invalid number format
484 Address Incomplete	21—Call rejected	28—Invalid number format
408 Request Timeout	21—Call rejected	41—Temporary failure
480 Temporarily unavailable	21—Call rejected	41—Temporary failure
486 Busy Here	21—Call rejected	17—User Busy
401 Unauthorized	21—Call rejected	32—Normal unspecified
407 Proxy Authentication Required	21—Call rejected	32—Normal unspecified
All other 4xx	21—Call rejected	16—Normal unspecified
502 Bad Gateway	38—Network out of order	28—Invalid number format
505 Bad Version	38—Network out of order	88—Incompatible destination
All other 5xx	38—Network out of order	16—Normal unspecified
600 Busy Everywhere	31—Normal unspecified	41—Temporary failure
603 Decline	31—Normal unspecified	31—Normal unspecified
604 Does Not Exist Anywhere	31—Normal unspecified	3—No route to destination
All other 6xx	31—Normal unspecified	31—Normal unspecified

## H.323 Events and Errors

The Q.850 cause code value is recorded for the disconnect cause in the CDR for the H.323 call leg if the Q.850 cause is received. H.323 recommendations state that either Q.850 Cause of RelCompReason is mandatory for the RELEASE COMPLETE; the Cause information element (IE) is optional everywhere. The Cause IE and the ReleaseCompleteReason (part of the release complete message) are mutually exclusive.

If a Q.850 cause code is not received, the SBC records a Q.850 cause value mapped from the received ReleaseCompleteReason as defined in the table below.

The entries in this table are determined by the [SIP Status to H.323 Disconnect Reason Mapping](#).

H.323 ReleaseCompleteReason	H.323 CDR Disconnect Cause	SIP Status	SIP CDR Disconnect Cause
No Bandwidth	34—No channel/circuit available	480 Temporarily Unavailable	21—Call rejected
Gatekeeper Resource	47—Resource unavailable	404 Not Found	21—Call rejected
Unreachable Destination	3—No route to destination	404 Not Found	21—Call rejected
Destination Rejected	31—Normal unspecified	603 Decline	31—Normal unspecified
Invalid Revision	88—Incompatible destination	505 Version Not Supported	38—Network out of order
No Permission	111—Interworking unspecified	401 Unauthorized	21—Call rejected
Unreachable Gatekeeper	38—Network out of order	503 Service Unavailable	38—Network out of order
Gateway Resource	42—Switching equipment congestion	480 Temporarily unavailable	21—Call rejected
Bad Format Request	28—Invalid number format	400 Bad request	21—Call rejected
Adaptive Busy	41—Temporary failure	486 Busy Here	21—Call rejected
In Conference	17—User busy	486 Busy Here	21—Call rejected
Undefined Reason	16—Normal unspecified	500 Internal Server Error	38—Network out of order
Called Party Not Registered	20—Subscriber absent	404 Not Found	21—Call rejected
Caller Not Registered	31—Normal call clearing		
New Connection Needed	47—Resource Unavailable	401 Unauthorized	21—Call rejected

## H.225 RAS Errors

For calls that are rejected because of H.225 RAS, there is no CDR generated for the H.323 call leg as no Setup message is generated. The SBC maps RAS errors to SIP Status as specified in the table below. The SIP CDR disconnect cause values are the same as the CSPS disconnect cause values already mentioned and defined.

The entries in this table are determined by the [SIP Status to H.323 RAS Error Mapping](#).

---

<b>H.225 RAS Error</b>	<b>SIP Status</b>	<b>SIP CDR Disconnect Cause</b>
Called Party Not Registered	404 Not Found	21—Call Rejected
Invalid Permission	401 Unauthorized	21—Call Rejected
Request Denied	503 Service Unavailable	38—Network out of order
Undefined	500 Internal Server Error	38—Network out of order
Caller Not Registered	401 Unauthorized	21—Call Rejected
Route Call to Gatekeeper	305 Use Proxy	23—Redirection to new destination
Invalid Endpoint ID	500 Internal Server Error	38—Network out of order
Resource Unavailable	503 Service Unavailable	38—Network out of order
Security Denial	401 Unauthorized	21—Call Rejected
QoS Control Not Supported	501 Not Implemented	38—Network out of order
Incomplete Address	484 Address Incomplete	21—Call Rejected
Route Call to SCN	302 Moved Temporarily	2—Redirection
Aliases Inconsistent	485 Ambiguous	21—Call Rejected
Not Currently Registered	401 Unauthorized	21—Call Rejected

---

# 6

## Diameter Accounting

The SBC supports the Diameter charging interface, Rf. This interface provides similar functionality to the RADIUS interface, but utilizes Diameter as the underlying application layer protocol. As a result, the SBC can integrate more thoroughly with IMS standards as well as provide a more dynamic, secure, and robust accounting interface.

### Diameter Accounting Messages

The Rf interface can send messages based on the signaling application's actions. These messages are Accounting Charging Request (ACR) Start messages, ACR Stop messages, Event messages and Interim messages.

### Resending ACRs

- If an ACA is not received to acknowledge the reception of an ACR, the SBC attempts to resend an ACR and buffers all subsequent ACRs for the same session until the acknowledgement is received. Once the acknowledgement is received from the CCF, all buffered ACRs for that same session may be sent to the CCF in the appropriate order. If the SBC does not receive the ACA after the user-specified number of retries, then the SBC sends all of the buffered ACR records for a session to the secondary CCF. (The number of ACR retries as well as the wait time in between retries is configurable by using the max-acr-retries account configuration parameters and acr-retry-interval, respectively.)

### Postponement Feature

- Any number of ACRs can be sent during a session, including Start, Stop, Interim and ACR messages. The ACR postponement feature (non-configurable) ensures that the next ACR is not sent until the previous ACR is acknowledged with an ACA.

### Call Flow Examples

- The following call flow example shows success in receiving an ACA for a session after resending the ACR message three times.

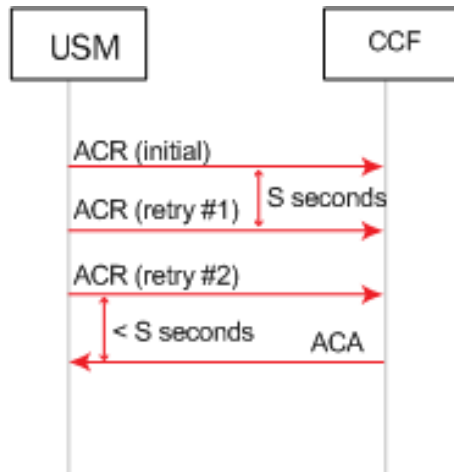

Successful ACA Acknowledgement After Three Retries

The following call flow example shows the failure to receive an ACA for a session after sending the ACR message three times.

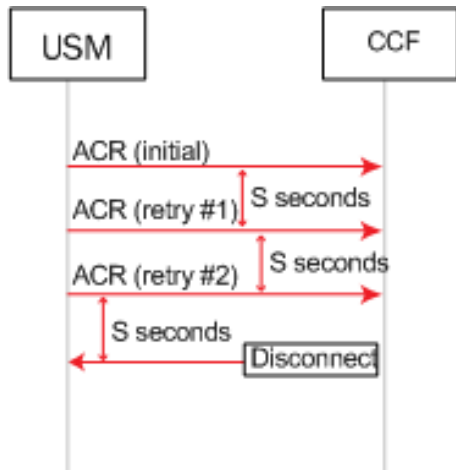

Unsuccessful ACA Acknowledgement After Three Retries

The following call flow example shows how the delay of the ACA acknowledgement for a session results in a postponement until the ACA is finally received. During the postponement, the ACRs are buffered until the corresponding ACA is received. If an ACR for one session is postponed, it does not delay the other session's ACRs.

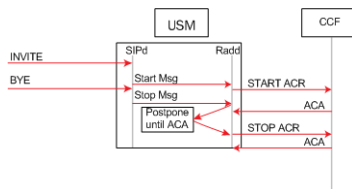

Call Flow Showing Delivery Postponement

- Additional ACR Interim messages are sent when service changes; this roughly maps to a RADIUS Interim-Update message. See [Accounting-Record-Type AVP \(480\)](#).
- ACR Stop messages are sent at the end of service delivery.

The SBC sends a set of AVPs in each ACR start and stop message that make up the charging data. The following table lists which AVPs are included in ACR Start and ACR Stop messages. Individual AVP descriptions are located in the following section.

AVP	ACR Start	ACR Stop
Session-Id AVP (263)	X	X
Origin-Host AVP (264)	X	X
Origin-Realm AVP (296)	X	X
Destination-Realm AVP (283)	X	X
Destination-Host AVP (293)	X	X
Accounting-Record-Type AVP (480)	X	X
Accounting-Record-Number AVP (485)	X	X
Acct-Application-Id AVP (259)	X	X
User-Name AVP (1)	X	X
Event-Timestamp AVP (55)	X	X
Event-Type AVP (823)	X	X
SIP-Method AVP (824)		
Content-Type AVP (826)		
Content-Length AVP (827)		
Role-of-Node AVP (829)	X	X
User-Session-Id AVP (830)	X	X
Calling-Party-Address AVP (831)	X	N/A
Called-Party-Address AVP (832)	X	N/A
Time-Stamps AVP (833)	X	X
SIP-Request-Timestamp AVP (834)		
SIP-Response-Timestamp AVP (835)		
Inter-Operator-Identifier AVP (838)	X	X
Originating-IOI AVP (839)		
Terminated-IOI AVP (840)		
SDP-Session-Description AVP (842)	X	N/A
Session-Media-Component AVP (845)	X	N/A
SDP-Media-Name AVP (844)		
SDP-Media-Description AVP (845)		
Cause AVP (860)	N/A	X
Cause-Code AVP (861)		
Node-Functionality AVP (862)		

## ACR AVP Descriptions

This section provides individual AVP descriptions.

### Session-Id AVP (263)

Uniquely identifies this session. It is a string value and is delimited by semi-colons. This AVP is created according to the Session-Id AVP (AVP Code 263) specified in IETF RFC 3588. An example of a Session-Id from the SBC is as follows, acmesystem;0;1.

## Origin-Host AVP (264)

Contains the account-server configuration element's **hostname** parameter followed by the "@" character, followed by the account-server configuration element's **origin-realm** parameter. For example: acmesystem@wancom.com.

## Origin-Realm AVP (296)

Contains the **account server** configuration element's **origin-realm** and **domain-name-suffix** parameters where the server request is sent.

## Destination-Realm AVP (283)

Contains the value of the Origin-Realm AVP in the CEA received from the accounting server for this connection.

## Destination-Host AVP (293)

Contains the value of the Origin-Host AVP in the CEA received from the accounting server for this connection.

## Accounting-Record-Type AVP (480)

Contains the value indicating the type of accounting message being sent.

- event record = 1
- start record = 2
- interim record = 3
- stop record = 4

## Accounting-Record-Number AVP (485)

A value that uniquely identifies this message in the session (i.e., a sequence number for this connection). The sequence number is assigned sequentially starting with 0 as described below. This is compliant with RFC 3588. The combination of the Accounting-Record-Number AVP and the Session-Id AVP (both of which are unique for the given session) are used to match accounting records with confirmations. This is done by assigning the noted values to the records listed below:

- Event Record — the system assigns this record a value of 0 to this record.
- Start Record — the system assigns this record a value of 0 to this record.
- Interim Record — the system assigns this record a value of 1 to the first record of this type for the session, and increments the value by 1 for each subsequent Interim\_record until the value for the Stop\_record is more for the last Interim\_record for the session.
- Stop Record — (see description for Interim\_record in the previous bullet) — If there is no Interim\_record for the session, the system assigns a value to this record of 1.

The following example call flow shows a Register Event that shows that the Event record in the Accounting-Record-Number AVP is always populated with 0.

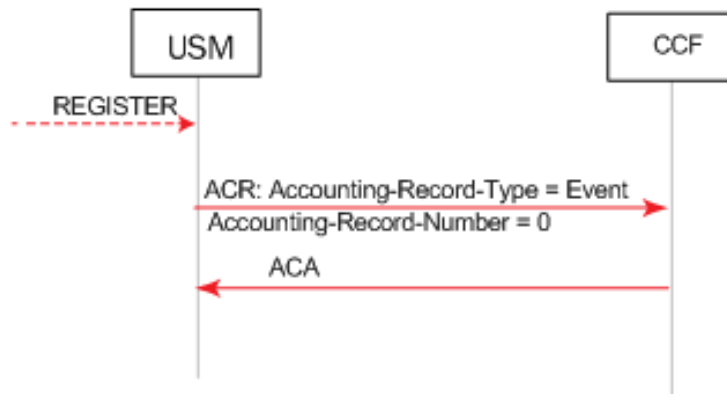

Register Event Call Flow Example

The following example call flow shows session accounting messages with no Interim records. Note that the Start Accounting-Record-Number equals 0 and the Stop Accounting-Record-Number equals 1.

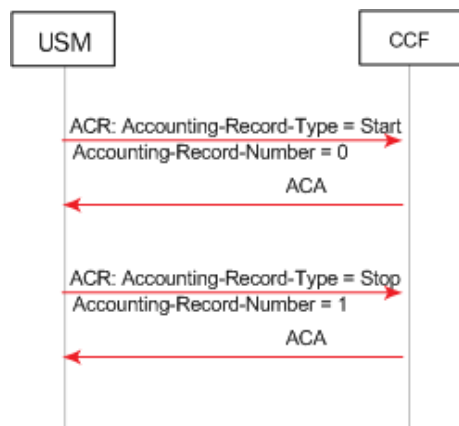

Call Flow Example Showing Session Accounting Messages with No Interim Records

The following example call flow shows session accounting messages with Interim records. Note that the Start record Accounting-Record-Number equals 0 and that the Interim Accounting-Record-Numbers start with a value of 1 and increase by 1 with the second Interim record. The Stop Accounting-Record-Number equals 3.



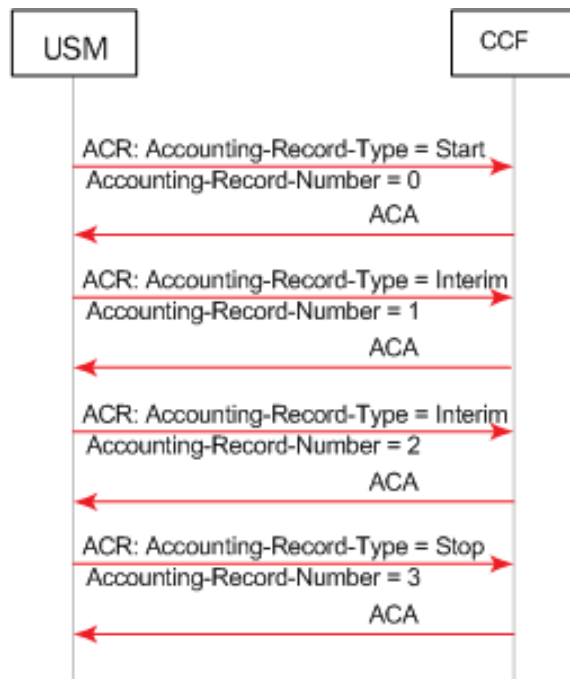

Call Flow Example Showing Session Accounting Messages with Interim Records

## Acct-Application-Id AVP (259)

Set to value "3". This value indicates Diameter-based accounting messages.

## User-Name AVP (1)

Contains the account-server configuration element's hostname parameter followed by the "@" character, followed by the account-server configuration element's origin-realm parameter. For example: acmesystem@wancom.com.

## Event-Timestamp AVP (55)

Contains the number of seconds since January 1, 1900 when this accounting event took place.

## Event-Type AVP (823)

A grouped AVP containing information about the signaling event. It contains the following AVPs:

- SIP-Method AVP (824)—Contains the exact string payload from the SIP request line; i.e., the Method that triggered the accounting event.
- Content-Type AVP (826)—Contains the exact string payload from the "Content-Type" SIP header of the message that triggered the accounting event.
- Content-Length AVP (827)—Contains the exact string payload from the Content-Length SIP header of the message that triggered the accounting event.

## Role-of-Node AVP (829)

Set to the value 2 which indicates that the SBC is operating in a PROXY role.

## User-Session-Id AVP (830)

Contains VSA 44 as used in the RADIUS interface.

## Calling-Party-Address AVP (831)

The Calling-Party-Address AVP (AVP code 831) is of type UTF8String and holds the address (SIP URI or TEL URI) which identifies the party (Public User Identity or Public Service Identity) initiating a SIP transaction. . It is obtained from the P-Asserted-Identity header of any non-REGISTER SIP Request, either initiating a dialog or a standalone transaction. This AVP may appear several times when the P-Asserted-Identity header contains both a SIP URI and a TEL URI. In case no P-Asserted-Identity is known, this AVP list shall include one item with the value "unknown".

## Called-Party-Address AVP (832)

The Called-Party-Address AVP (AVP code 832) is of type UTF8String. In IMS charging (except for SIP Register and SIP Subscription transactions), it holds the address (SIP URI, TEL URI or URN) of the party (Public User ID or Public Service ID) to whom the SIP transaction is posted. The Called Party Address shall be populated with the SIP URI or TEL URI contained in the Request-URI of the outgoing request.

For a registration procedure, this field holds the party (Public User ID) to be registered. In this case, the Called Party Address field is obtained from the To SIP header of the SIP Request. For a subscription procedure this field holds the address of the resource for which the originator wants to receive notifications of change of states. In this case, the Called Party Address field is obtained from the outgoing Request-URI of the SIP Request.

## Time-Stamps AVP (833)

A grouped AVP that contains timestamps for the related SIP signaling. It contains the following AVPs.

- SIP-Request-Timestamp AVP (834)—A UTC formatted timestamp that corresponds to when the SIP INVITE that started the session was received.
- SIP-Response-Timestamp AVP (835)—A UTC formatted timestamp that corresponds to when the SIP 200 OK response to the INVITE that started the session was received.

## Inter-Operator-Identifier AVP (838)

A grouped AVP that indicates the ingress and egress networks from the SBC's perspective. It contains the following AVPs.

- Originating-IOI AVP (839)—The realm where the SBC received the SIP signaling messages.
- Terminated-IOI AVP (840)—The realm where the SIP signaling message exit the SBC.

## SDP-Session-Description AVP (842)

This AVP may occur multiple times in an ACR message. It is populated with SDP attribute-lines from the SIP messages to which this ACR Start or Interim message refers. Thus, all "i=", "c=", "b=", "k=", "a=", etc., lines comprise multiple instances of this AVP.

If the SBC is configured to generate Start events on the INVITE, the calling SDP will be used; if the SBC is configured to generate Start events on the OK, the called SDP will be used. ONLY IN ACR Start.

## Session-Media-Component AVP (845)

A grouped AVP that contains information about the media session. It contains the following AVPs. ONLY IN ACR Start.

- SDP-Media-Name AVP (844)—populated with the "m=" line from the SDP being used.
- SDP-Media-Description AVP (845)—this AVP may occur multiple times in this grouped AVP. It is populated with SDP attribute-lines from the media component as specified by the media described in the SDP-Media-Name AVP. Thus, all "i=", "c=", "b=", "k=", "a=", etc..., lines related to the above specified "m=" line comprise multiple instances of this AVP.

## Cause AVP (860)

A grouped AVP that contains the reason for the termination event and the role/function of the node where the call was terminated. It contains the following AVPs.

- Cause-Code AVP (861)—See Values for Cause Code AVP (861) below.
- Node-Functionality AVP (862)—Set to value 0.

## Reason-Header AVP (3401)

The Reason-Header AVP (3401), is a UTF8 string that contains the content of the Reason-header detected by the SBC in SIP BYE, CANCEL, and SIP error responses. It may contain multiple entries if the system detects multiple reason headers. The system includes this AVP in the ACR for Accounting-Record-Type [STOP/EVENT] when there is an active **account-config** running diameter, and you have enabled the **add-reason-header** parameter in the **sip-config**.

The SBC expects this AVP in an ACR message, as follows follow.

AVP	Number	AVP Type	Reference	Start	Interim	Stop	Event
[ Reason-Header AVP ]	3401	UTF8 String	Base	N	N	Y	Y

The syntax of the Reason-Header AVP is:

```
AVP: Reason-Header(3401) l=49 f=VM- vnd=TGPP
val=Q.850;cause=16;text="Call Terminated"
AVP Code: 3401 Reason-Header
```

```
AVP Flags: 0xc0, Vendor-Specific: Set, Mandatory: Set
AVP Length: 49
AVP Vendor Id: 3GPP (10415)
Reason-Header: Q.850;cause=16;text="Call Terminated"
Padding: 000000
```

- AVP: Reason-Header(3401) l=49 f=VM- vnd=TGPP val=Q.850;cause=16;text="Call Terminated"
- AVP Code: 3401 Reason-Header
- AVP Flags: 0xc0,
- Vendor-Specific: Set, Mandatory: Set
- AVP Length: 49
- AVP Vendor Id: 3GPP (10415)
- Reason-Header: Q.850;cause=16;text="Call Terminated"
- Padding: 000000

## Values for Cause Code AVP (861)

As described in 3GPP TS32.229, the Cause-Code AVP 861 includes the cause code value sent by the IMS node. It is used in stop and/or event messages.

If the session terminated as a result of a specific known SIP error code, the SIP error code is used as the cause code value. Otherwise, cause code values less than or equal to 0 are used for successful causes while values greater than or equal to 1 are used for failure causes.

- Cause code value set to 0 — indicates "Normal end of session" and is used in Accounting-request[stop] message to indicate that an ongoing SIP session has been normally released either by the user or by the network (SIP BYE message initiated by the user or initiated by the network has been received by the IMS node after the reception of the SIP ACK message).
- Cause code value set to "2xx Final Response" (except 200) — used when the SIP transaction is terminated due to an IMS node receiving/initiating a 2xx Final response.
- Cause code value set to "2xx Final Redirection"— used when the SIP transaction is terminated due to an IMS node receiving/initiating a 3xx response.
- Cause code value set to "1"— indicates "Unspecified error" and is used when the SIP transaction is terminated due to an unknown error.
- Cause code value set to "4xx Request failure"— used when the SIP transaction is terminated due to an IMS node receiving/initiating a 4xx error response.
- Cause code value set to "5xx Server failure"— used when the SIP transaction is terminated due to an IMS node receiving/initiating a 5xx error response.
- Cause code value set to "6xx Global failure"— used when the SIP transaction is terminated due to an IMS node receiving/initiating a 6xx error response.
- Cause code value set to "Unsuccessful session setup"— used in the Accounting-request[stop] when the SIP session has not been successfully established (i.e. Timer H expires and SIP ACK is not received or SIP BYE is received after reception of the 200OK final response and SIP ACK is not received).

- Cause code value set to "Internal error"— used when the SIP transaction is terminated due to an IMS node internal error (e.g. error in processing a request/response).

## STIR/SHAKEN AVPs

The SBC issues custom AVPs that capture STIR/SHAKEN information within ACRs. These are in addition to the AVPs that are common to all traffic.

This table lists STIR/SHAKEN AVPs for DIAMETER CDRs and captures the applicable CDR message types.

AVP Name	Number	Start	Interim	Stop	Message Type = INVITE	AVP Type
Stir-Signed-Request	104	Yes (On 200OK of invite)	Yes	Yes	Yes	String
Stir-Signed-Request-Exception-Id	105	Yes (On 200OK of invite)	Yes	Yes	Yes	String
Stir-Verified-Request	106	Yes	Yes	Yes	Yes	String
Stir-Verified-Request-Exception-Id	107	Yes	Yes	Yes	Yes	String
Stir-VS-Verstat	108	Yes	Yes	Yes	Yes	UTF8String
Stir-VS-Reason	109	Yes	Yes	Yes	Yes	String
Stir-TN-Used-For-AS-VS-Request	110	Yes	Yes	Yes	Yes	String
Stir-Div-Signed-Request	111	Yes (If generate-start = OK)	Yes	Yes	Yes	String
Stir-Div-Verified-Request	112	Yes	Yes	Yes	Yes	String

### Stir-Signed-Request AVP (104)

This AVP indicates that the SBC has sent the signing request to the STI-AS and received a response. Values for this AVP mean:

- 1— The SBC has signed the INVITE.
- 0—The SBC has not signed the INVITE.
- 2—Signing is not applicable for the INVITE.

## Stir-Signed-Request-Exception-Id AVP (105)

This AVP indicates that the SBC did not sign the request because of a failure request from the STI-AS. It includes the ATIS defined service or policy exception code. Potential values are in the next table.

Exception ID	Exception Text	HTTP Status Code
SVC4000	Missing request body.	400
SVC4001	Missing mandatory parameter '%1'	400
SVC4002	Requested response body type '%1' is not supported	406
SVC4003	Requested resource was not found	404
SVC4004	Unsupported request body type, expected '%1'	415
SVC4005	Invalid '%1' parameter value: %2	400
SVC4006	Failed to parse received message body: %1	400
SVC4007	Missing mandatory Content-Length header 411	411
POL4050	Method not allowed	405
POL5000	Internal Server Error. Please try again later	500

## Stir-Verified-Request AVP (106)

This AVP indicates that the SBC has sent the verification request to the STI-VS and received a response. Values for this AVP mean:

- 1— The SBC has verified the request.
- 0—The SBC has not signed verified the request.
- 2—Request verification is not applicable for the call.

## Stir-Verified-Request-Exception-Id AVP (107)

This AVP indicates that the SBC did not verify the request because of a failure request from the STI-VS. It includes the ATIS defined service or policy exception code. Potential values are in the next table.

Exception ID	Exception Text	HTTP Status Code
SVC4000	Missing request body	400
SVC4001	Missing mandatory parameter '%1'	400
SVC4002	Requested response body type '%1' is not supported	406
SVC4003	Requested resource was not found	404

Exception ID	Exception Text	HTTP Status Code
SVC4004	Unsupported request body type, expected '%1'	415
SVC4005	Invalid '%1' parameter value: %2	400
SVC4006	Failed to parse received message body: %1	400
SVC4007	Missing mandatory Content-Length header 411	411
POL4050	Method not allowed	405
POL5000	Internal Server Error. Please try again later	500

## Stir-VS-Verstat (108)

The SBC populates the Stir-VS-Verstat RADIUS attribute with the verstat values the SBC includes in the SIP INVITE following the Stir Shaken trigger with the values include TN-Validation-Passed, TN-Validation-Failed or No-TN-Validation in the cases below. DIV verification apply to 3GPP mode only.

The SBC includes a verstat in the INVITE and CDR:

- For SHAKEN verifications, when the SBC receives a verstat value parameter in the HTTP response from STI-VS server.
- For DIV verifications, when the SBC receives multiple verstat value parameters in a single HTTP response from the STI-VS server, and a specified final verstat value.
- For both DIV and SHAKEN verifications, when the SBC does not send a VS request to the STI-VS server, it adds the No-TN-Validation verstat to the egress INVITE. This may happen, for example, when the ingress INVITE doesn't have the Identity header.
- For both DIV and SHAKEN verifications, when the SBC does not receive any response from the STI-VS server, it adds the No-TN-Validation verstat to the egress INVITE. An example of this is a timeout.
- The SBC populates Stir-VS-Verstat with an empty string in the following cases:
  - For all authentication scenarios
  - If there is a timeout
  - If the system does not send a request to the STI-VS because there is an existing Identity header
  - For verification scenarios wherein the system receives a 4xx/5xx response from the STI-VS because the verstat and reason fields are not included in the json response
  - If the STI-VS response does not have a Verstat Value
  - For ATIS deployments, if the STI-VS response has empty reasoncode and reasontext fields

Enable the **account-config, cdr-output-inclusive** parameter to include the empty strings for the scenarios above. If disabled, the system does not include the AVP in the CDR file.

## Stir-VS-Reason (109)

From a high level, this AVP reflects what the SBC includes in the SIP egress INVITE following the Stir Shaken trigger. The SBC populates the Stir-VS-Reason attribute with received reason information in the cases below, based on operating mode.

- When operating in ATIS mode, if you have enabled the **reason-json-sip-translation** feature and the system receives the reasoncode and reasontext parameters in the HTTP response
- When operating in 3GPP mode, if you have enabled the **reason-json-sip-translation** feature and the system receives an error response, either 4xx or 5xx, from the STI-VS, the SBC uses the HTTP error code and reason phrase (if available) to populate a reason header in the egress INVITE

The SBC populates Stir-VS-Reason with an empty string in the following cases:

- When the **reason-json-sip-translation** feature is disabled
- For all authentication scenarios, regardless of whether the feature is enabled or disabled
- If there is a timeout
- If the system does not send a request to the STI-VS because there is an existing Identity header
- For both DIV and SHAKEN verifications, when the feature is enabled and the system receives a 4xx or a 5xx verification response because the verstat and reason fields are not included in the json response

 **Note:**

This is only true for ATIS 3GPP deployments.

Enable the **account-config, cdr-output-inclusive** parameter to include the empty strings for the scenarios above. If it's disabled, the system does not include the AVP in the CDR file.

## Stir-TN-Used-For-AS-VS-Request (110)

This AVP contains the TN number captured by the SBC. The TN to be used in the CDRs uses the following priority order:

1. From the Tel PAI (if present)
2. From the SIP PAI (if present, and Tel PAI is not present)
3. From the "From" header if both Tel and SIP PAI are not present.

## Stir-Div-Signed-Request (111)

Upon sending the div signing request to the STI-AS and receiving a 200 OK successful response from STIR-AS, the SBC enumerates the results as follows:

- "1" for div signing the INVITE
- "0" for not div signing the INVITE
- "2" when div signing is not applicable on the INVITE



## Stir-Div-Verified-Request (112)

Upon sending the div verify request to the STI-AS and receiving a 200 OK successful response from STIR-VS, the SBC enumerates the results as follows:

- “1” for div verification of the INVITE
- “0” for no div verification of the INVITE
- “2” when div verification is not applicable on the INVITE

## ACR Event Records

The SBC supports ACR [Event] records, according to 3GPP TS 32.260. This is in addition to start, stop and interim records. These records reflect a preset type of SIP event. The ACRs are then sent to the CCF.

The SBC can create Event ACR messages on REGISTER, local-re-REGISTER and/or Short Message Service (SMS) message requests. A local re-register is when registration caching is enabled and the REGISTER from an currently registered endpoint occurs before half of the registration expiration time. In such cases the SBC sends a 200 OK to the re-registering endpoint and does not forward the re-REGISTER to the registrar. A message is an SMS event, on which the SBC collects critical RF information.

Event record creation is enabled with the **generate-event** parameter in the account config. This parameter can be set to register, local-register, message or any combination of all three values. The configured value(s) indicates the type of message that initiates an event ACR message sent to a CCF. Register only prompts the SBC to create Event ACRs at a REGISTER. Local-register prompts the SBC to create Event ACRs on a re-REGISTER that was replied to by the SBC. Message prompts the SBC to create EVENT ACRs sending information on SMS traffic within STOP records.

Event messages are created when the SBC receives a SIP Final Response 2xx or SIP Final Response (4xx or 5xx), that indicates an unsuccessful REGISTER.

Event ACR messages are also generated to indicate there has been an unsuccessful session attempt. Upon receiving a 4xx, 5xx or 6xx response to a SIP Invite, an Event message is created.

## ACR Event Message Construction

An Event ACR is generated according to the tables that describe the AVPs present in the SBC's ACR message. Refer to the checked items in the Event column to see all included AVPs. Note that the Accounting-Record-Type AVP (480) is set to Event\_Record (1).

## Event-Type AVP

The Event-Type AVP (AVP code 823) is a Grouped AVP and contains information about the type of chargeable telecommunication service/event for which the accounting-request and/or credit control request message(s) is generated.

It is used in an AAR Event record. In this context, refer to the following:

AVP	Number	Acme #	Definition
[ SIP-Method ]	824	173	Contains the name of the SIP Method. Values include REGISTER or MESSAGE (for SMS). These generate an accounting request to the CCF.
[ Event ]	825	245	Holds the content of the "Event:" header. This is not present in a REGISTER or re-REGISTER message
[ Expires ]	888	246	Holds the content of the "Expires" header. Upon a re-REGISTER this value is the time remaining until the endpoint's registration expires.

The SBC generates additional information for SMS and distributes the information within the SIP-Method grouped AVP.

## Expires Value

A refresher on the expires value: If the Contacts: header does not contain an expires parameter, the SBC adds one with the value in the Expires: header in the 200 OK returned to the UA who sent the INVITE. If there is no Expires: header, the SBC adds expires parameter with a value of 3600 and an Expires header with a value of 3600 to the 200 OK.

As the SBC forwards the final 200 OK to the initiating endpoint, the Expires (888) AVP contains the largest expires value of all expires parameters in Contact: headers.

When registration caching is enabled and the SBC receives a reREGISTER from an endpoint before the halftime of the local registration has expired, the SBC inserts the maximum of all associates contacts' remaining time until expiry in the Expires AVP.

## Event ACRs Generated for Unsuccessful Session Attempts

When any of the following responses are received in response to a SIP Invite, an Event ACR message is created to indicate there has been an unsuccessful session attempt:

- 4xx Request Failure Code — this code is used when the SIP transaction is terminated due to an IMS node receiving a 4xx error response.
- 5xx Server Failure Code — this code is used when the SIP transaction is terminated due to an IMS node receiving a 5xx error response.
- 6xx Global Failure Code — this code is used when the SIP transaction is terminated due to an IMS node receiving a 6xx error response.

This example call flow shows how a 5xx server failure results in the sending of an Event ACR.

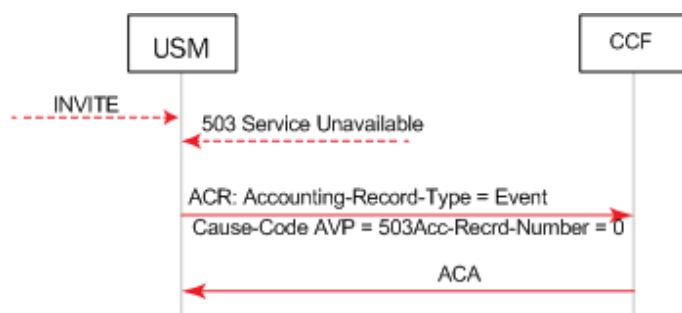

### Call Flow Example Showing Event ACR Generation Due to 5xx Server Failure

The following call flow example shows two session agents. The first session agent replies with 503, which results in an Event ACR with cause code 503. The second session agent replies with 200OK that causes the sending of a Start ACR. The generate-start parameter is OK.

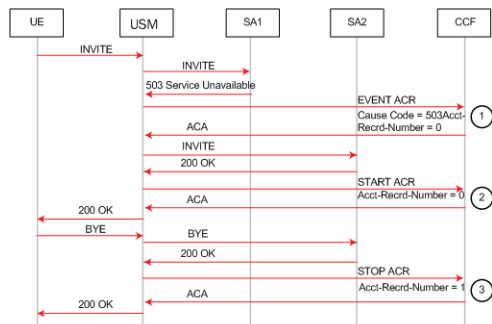

### Call Flow Example Showing Sending of an Event and Start ACR

This example call flow illustrates the same call flow when generate-start are equal to Invite. In this case, Start, Interim and Stop ACRs are sent. The generate-start parameter is OK.

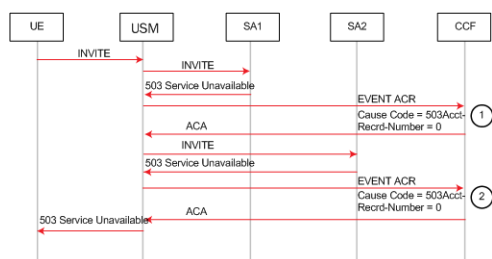

### Call Flow Example Showing Generation of Event ACRs Due to 5xx Server Failures

This example call flow shows how a session is created and a Start ACR is sent but then a 5xx server failure occurs that results in sending an Interim ACR. The generate-start parameter is Invite.

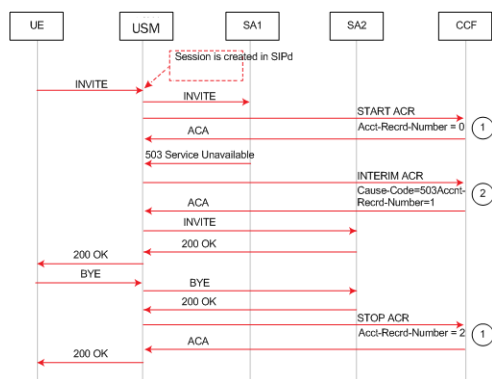

### Call Flow Example Showing Sending of Start and Interim ACRs

This example call flow shows how the SD rejects a call before a session is created. When the enhanced-cdr option is not set, an Event ACR is then sent.

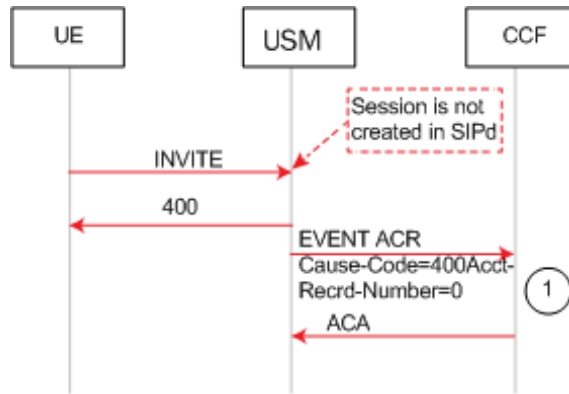

Call Flow Example Showing Unsuccessful Session Creation and Sending of a Event ACR

## Event ACRs Generated for Receipt of SIP Messages

An Event ACR is issued when the following SIP messages are received:

- 200 OK message for a SIP Register from the IMS core.
- SIP Final/Redirection Response 3xx
- SIP Final Response (4xx, 5xx or 6xx) — this indicates an unsuccessful session-unrelated procedure.
- SIP Final Response (4xx, 5xx or 6xx) — this indicates an unsuccessful SIP session set-up.

This example call flow shows an Event ACR that is created due to the reception of a 3xx SIP message. In this example the call fails after being redirected.

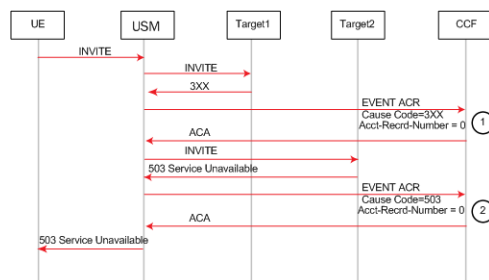

Event ACR Created Upon Reception of a 3xx Message Followed by Call Failure After Redirect

This example call flow shows an Event ACR that is created due to the reception of a 3xx SIP message. Then it shows a Start ACR upon reception of a 200OK. In this example the call succeeds after being redirected. The generate-start is OK.

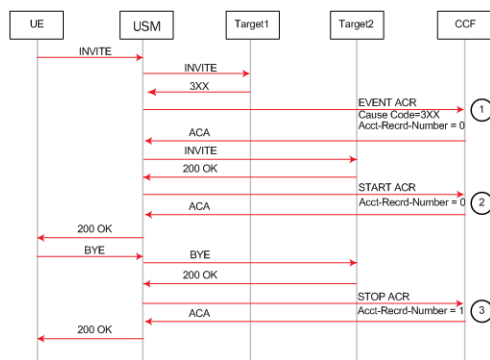

Event ACR Created Upon Reception of a 3xx Message Followed by Call Success After Redirect

This example call flow shows a Start ACR being sent when an Invite is received and an Interim ACR that is created due to the reception of a 3xx SIP message. In this example the call succeeds after being redirected. The generate-start is Invite.

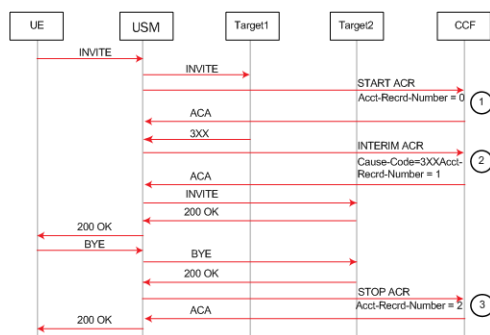

## Event ACRs for SMS

The SBC generates call data event records with information for SMS that differs somewhat from that of calls. You configure the SBC to generate ACRs for SMS using the same procedures you use for calls, which then treats the SMS messages as events, similar to call data during registrations.

End stations send SMS messages using a SIP MESSAGE (content-type=application/vnd.3gpp.sms) with a GSM-SMS body. The SBC complies with 3GPP specifications 23.040 (Technical realization of the Short Message Service (SMS) and 24.011 Point-to-Point (PP) Short Message Service (SMS) support on mobile radio interface) with respect to message format. The SBC parses message information for AVP data during message processing and ultimately provides ACRs to the CCF using the Rf interface.

SMS processing that includes ACR generation includes a separate timer, the **sms-report-timeout** within the **sip-config**, for SMS accounting. If the SBC does not receive a delivery report /submit report within this timer's value, it discards all accounting for that message. The diagrams below present the start and stop locations of this timer within the context of overall ACR generation.

The call flow diagram below illustrates the SBC, as P-CSCF, gathering data for the SMS report during a message originating scenario. The SBC ultimately issues the ACR after the message delivery is complete.

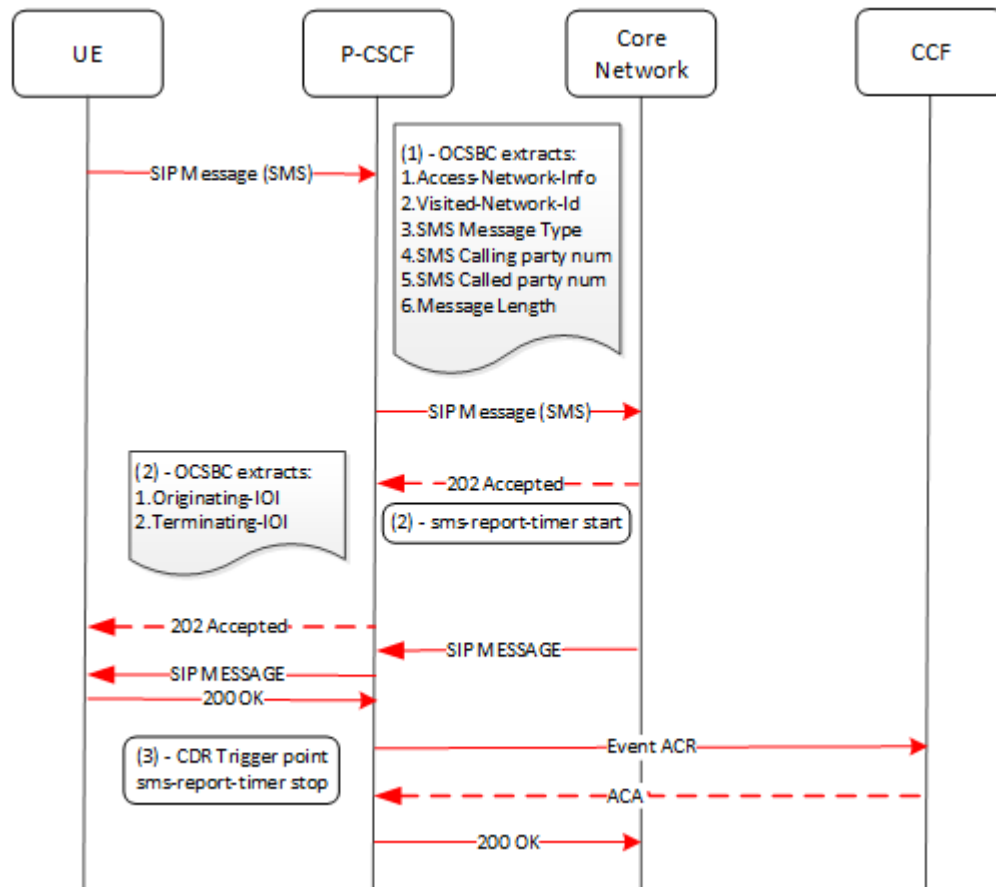

The call flow diagram below illustrates the SBC, as P-CSCF, gathering data for the SMS report during a message terminating scenario.

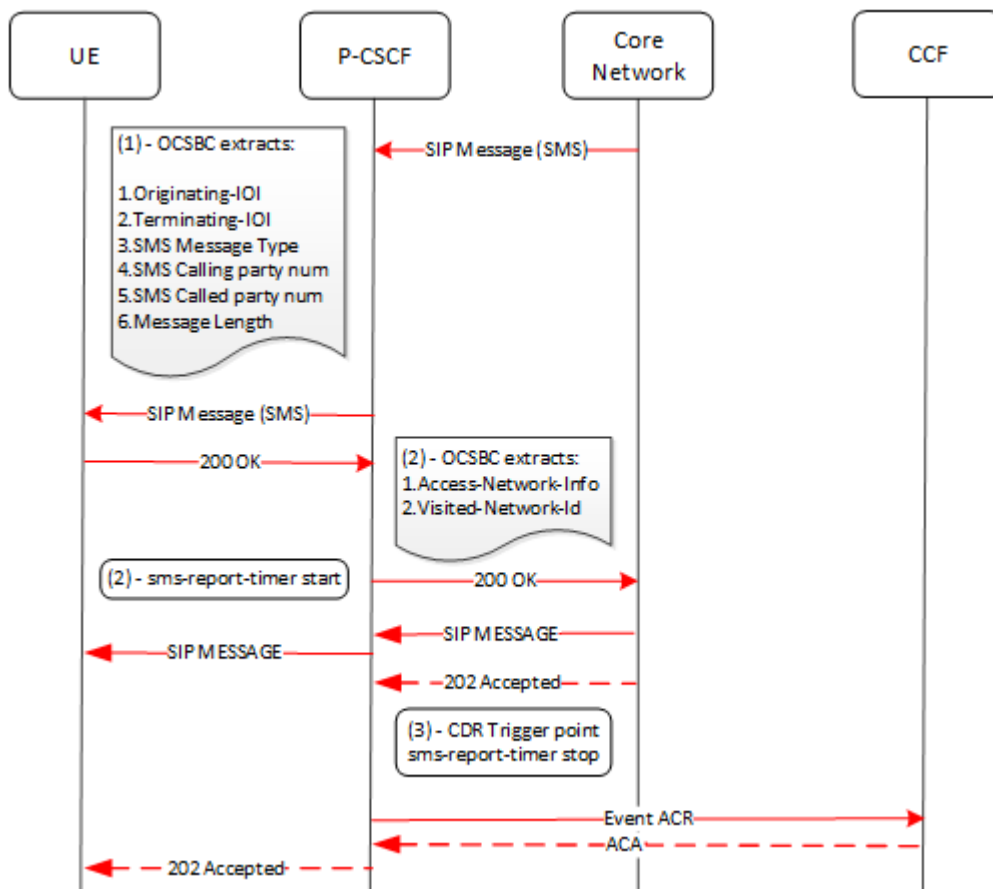

## VoLTE Call and SMS AVPs for Diameter

The SBC issues custom AVPs that capture VoLTE and SMS information within ACRs. These are in addition to the common AVPs for all traffic. The process for VoLTE calls is the same as all other calls. For SMS, the process is different given that the message is an event, and the data recorded on the message equates to what is recorded for a call session.

The table below identifies AVPs specific to VoLTE and SMS traffic.

AVP	ACME Diameter Attribute	Start	Interim	Stop	Event = MESSAGE	AVP Type
Pgw-IP	95	Y	Y	Y	N	UTF8String
Sgw-IP	96	Y	Y	Y	N	UTF8String
IMEI	97	Y	Y	Y	Y	UTF8String
IMSI	98	Y	Y	Y	Y	UTF8String
History-Info	99	Y	Y	Y	N	UTF8String
Sms-Msg-Type	100	N	N	N	Y	UTF8String
Sms-called party-Number	101	N	N	N	Y	UTF8String

AVP	ACME Diameter Attribute	Start	Interim	Stop	Event = MESSAGE	AVP Type
Sms-calling party-Number	102	N	N	N	Y	UTF8String
Sms-Msg-Length	103	N	N	N	Y	Unsigned32

### Diameter AVPs for VoLTE Calls

The SBC sends an ACR to the PCRF for call accounting with the following VoLTE-specific AVPs. The table shows all mandatory and optional AVP's. If there is data, the SBC includes Optional AVPs. If not the SBC does not include them.

AVP Name	AVP Code	Is grouped? Group hierarchy	Type
Access-Network-Information	1263	Yes [ACR]   [Service-Information]   [IMS Information]   [Access-Network-Information]	String
IMS-Visited-Network-Identifier	2713	Yes [ACR]   [Service-Information]   [IMS Information]   [IMS-Visited-Network-Identifier]	String
Originating-IOI	839	Yes [ACR]   [Service-Information]   [IMS Information]   [Inter-Operator-Identifier]   [Originating-IOI]	String
Terminating-IOI	840	Yes [ACR]   [Service-Information]   [IMS Information]   [Inter-Operator-Identifier]   [Terminating-IOI]	String

In addition, the SBC sends the following fields as custom AVP's in the ACR.

AVP Name	AVP Code	Type
IMSI	98	UTF8String
IMEI	97	UTF8String
History-Info	99	UTF8String
PGW-IP Address	95	UTF8String
SGW-IP Address	96	UTF8String



**Diameter AVPs for SMS Messages**

The SBC sends an ACR to the PCRF for MESSAGE accounting with the following SMS-specific AVPs. The table shows all mandatory and optional AVP's. If there is data, the SBC includes Optional AVPs. If not the SBC does not include them.

AVP Name	AVP Code	Is grouped? Group hierarchy	Type
Session ID	263	No	String
Origin Host	264	No	String
Origin Realm	296	No	String
Destination Realm	283	No	String
Origin State ID	278	No	Unsigned Int
Accounting Record Type	480	No	Enum
Accounting-Record-Number	485	No	Unsigned Int
Accounting App ID	259	No	Unsigned Int
Event Timestamp	55	No	Time
Service Context ID	461	No	String
Subscription-Id-Type	450	Yes [ACR]   [Service-Information]   [Subscription ID]   [Subscription-Id-Type]	Enum
SIP-Method	824	Yes [ACR]   [Service-Information]   [IMS Information]   [Event-Type ]   [SIP-Method]	String
Role-Of-Node	829	Yes [ACR]   [Service-Information]   [IMS Information]   [Role-Of-Node]	Enum
Node Functionality	862	Yes [ACR]   [Service-Information]   [IMS Information]   [Node Functionality]	Enum
SIP-Request-Timestamp	834	Yes [ACR]   [Service-Information]   [IMS Information]   [Timestamp ]   [SIP-Request-Timestamp]	Time

AVP Name	AVP Code	Is grouped? Group hierarchy	Type
SIP-Response-Timestamp	835	Yes [ACR]   [Service-Information]   [IMS Information]   [Timestamp]   [SIP-Response-Timestamp]	Time
SIP-Request-Timestamp-Fraction	2301	Yes [ACR]   [Service-Information]   [IMS Information]   [Timestamp]   [SIP-Request-Timestamp-Fraction]	Unsigned Int
SIP-Response-Timestamp-Fraction	2302	Yes [ACR]   [Service-Information]   [IMS Information]   [Timestamp]   [SIP-Response-Timestamp-Fraction]	Unsigned Int
Access-Network-Information	1263	Yes [ACR]   [Service-Information]   [IMS Information]   [Access-Network-Information]	String
IMS-Visited-Network-Identifier	2713	Yes [ACR]   [Service-Information]   [IMS Information]   [IMS-Visited-Network-Identifier]	String
Originating-IOI	839	Yes [ACR]   [Service-Information]   [IMS Information]   [Inter-Operator-Identifier]   [Originating-IOI]	String
Terminating-IOI	840	Yes [ACR]   [Service-Information]   [IMS Information]   [Inter-Operator-Identifier]   [Terminating-IOI]	String

In addition, the SBC sends the following fields as custom AVP's in the ACR.

AVP Name	AVP Code	Type
IMSI	98	UTF8String
IMEI	97	UTF8String
SMS MSG Type	100	UTF8String

AVP Name	AVP Code	Type
SMS Calling party number	102	UTF8String
SMS Called party number	101	UTF8String
Message Length	103	Unsigned32

## Distinct VoLTE Processes

For VoLTE calls, the process for generating CDRs is the largely the same as for other calls. As described, there are additional data points included for these call types.

In addition, the list below presents additional processes reserved for VoLTE data management with which you should be familiar:

- When there is an SRVCC event, the SBC creates a separate set of CDRs for the handover session. The SBC correlates the original and handover session using the "Generic-ID" field, which points to the Call-ID of the initial session. In addition, the SBC populates the Generic-ID field within the Initial Session CDRs (STOP), with the HO session Call-ID.
- The SBC copies the Call id of the second INVITE (Handover INVITE) into the Generic Id into the CDR for the first INVITE (initial call) for both MO and MT call
  - For mobile originating call—When the SBC receives the 200 Ok for the BYE from UE, it inserts the Call id of second INVITE, which is generated from the MSC-S as Generic Id, into the CDR of First MO Invite (Before the handover call).
  - For mobile terminating call—When the SBC receives the 200 Ok for the BYE from UE, it inserts the Call id of the second INVITE, which is generated from the MSC-S as Generic Id, into the CDR of the first MT INVITE (before the handover call).
  - If there is a negative case, such as a BYE timeout, the SBC writes the Call id of second INVITE, which is generated from the MSC-S as the Generic Id, into the CDR of the first INVITE (before the handover call) when that corresponding call gets terminated.



### Note:

The SBC performs these same processes for both RADIUS accounting when generating CDRs and Diameter accounting when generating ACRs.

## Configurations to Specify VoLTE and SMS Data

You can configure the SBC to use specific data in call data records provided over RADIUS, Diameter and within local CSVs. This ensures that the specified fields

There are two configurations available for specifying VoLTE and SMS data:

- Subscribe to IP-CAN-CHANGE events
- Specify Inter-Operator Identifier (IOI)

## Subscribe to IP-CAN-CHANGE Events

You can configure a subscription to the IP-CAN-CHANGE event using the Rx interface during the AAA/RAR exchange. To do this, you configure the **ip-can-change** value to the **specific-action-subscription** of the applicable **ext-policy-config**. This causes the SBC to apply the value in the AN-GW-Address AVP from the PCRF as the S-GW IP address.

### Note:

If the SBC receives more than one AN-GW-Address AVP from the PCRF, it applies the value in the AN-GW-Address AVP from the PCRF. It also uses the S-GW IP address the first AVP as the S-GW IP address.

## Option to Specify IOI

You configure the **realm-as-ioi** option in the applicable **account-config** to send the realm name as the IOI in diameter ACRs. If this option is not set, the SBC uses the IOI from the charging vector.

Configure this option using the syntax below.

```
ORACLE (account-config) # options +realm-as-ioi
```

If you type options and then the option value without the plus sign, you overwrite any previously configured options. To add a new option to an options list, pre-pend the new option with a plus sign as shown in the previous example.

## Configuring the ip-can-change Subscription

You use the steps below to Subscribe to IP-CAN-CHANGE events at the PCRF and apply the value in the AN-GW-Address AVP from the PCRF as the S-GW IP address.

To obtain the S-GW IP address for mobile originating and terminating scenarios and provide that data in CDRs for RADIUS, diameter and local CSVs:

1. In Superuser mode, type **configure terminal** and press Enter.

```
ORACLE# configure terminal
```

2. Type **media-manager** and press Enter.

```
ORACLE (configure) # media-manager
```

3. Type **ext-policy-config** and press Enter.

```
ORACLE (session-router) # ext-policy-config  
ORACLE (ext-policy-config) #
```

4. Type **specific-action-subscription ip-can-change** and press Enter.

```
ORACLE (session-router) # specific-action-subscription ip-can-change  
ORACLE (ext-policy-config) #
```

The **specific-action-subscription** accepts multiple values. When configuring 2 or more specific actions, enclose them in quotation marks, with the values separated by spaces.

5. Save your work.

## Event Local CSV File

This feature also creates an Event CSV file when the **generate-event** parameter is enabled. The following table describes the inclusive CSV element order:

CSV Placement	Attribute Name	AVP Number
1	Record Type	480
2	NAS IP Address	
3	NAS Port	16
4	Calling Station ID	
5	Called Station ID	
6	Diameter Session ID	263
7	SIP Method	824
8	Event Time	55
9	User Name	1
10	Node Function	862
11	Application ID	259
12	Role Node	829
13	Event	825
14	Expires	888
15	Associated URI	856
16	Cause Code	861
17	CDR Sequence Number	
18	Origin Realm	296
19	Origin Host	264
20	Destination Realm	283
21	Destination Host	

The SBC generates a different CSV for message events, triggered by SMS traffic. This layout is presented in Appendix B.

## Diameter Heartbeat for Rf

Device-Watchdog-Request (DWR) and Device-Watchdog-Answer (DWA) messages are used to detect transport failures at the application layer between the SBC communicating with a policy server via Diameter. The request/answer message pair forms a heartbeat mechanism that can alert the requesting side if the answering side is not reachable.

The SBC always responds to a DWR by replying with a DWA message. In addition, the SBC can be configured to initiate DWR messages toward a policy server or other Diameter-based network device.

You configure the **watchdog ka timer** to indicate the period between the DWRs the SBC sends to a Diameter Agent, an Rf based server in this case.

If the SBC fails to receive a DWA response from the Server within 1/4 of the configured **watchdog ka timer** parameter, then the connection towards that Server is considered failed and torn down. The SBC attempts to recreate the TCP connection, followed by the recreating the Diameter connection by issuing a CEA toward the policy server.

When other Rf traffic to/from the accounting server is present, DWRs are suspended. The other traffic indicates that the server is up. The SBC upon detection of DWR failure can send accounting data towards another configured accounting server by failover/strategy mechanisms.

## Using FQDNs to Access CCFs over Diameter

You can configure the SBC with a primary and, if desired, a secondary FQDN to access CCF servers over Diameter. You do this by configuring the diameter **account-server** with an FQDN. The SBC uses DNS to resolve the FQDN into an IP list and, if provided, route the traffic based on DNS-provided priority and weight. The SBC supports resolution of CCF FQDNs from SRV, and A records.

Upon configuration, the SBC can perform a DNS resolution procedure to resolve a configured FQDN to one or more IP addresses. When the SBC receives the DNS response, it extracts the IP address(es). Each IP address corresponds to one CCF. For each IP address, the SBC next establishes a TCP connection and performs a CER and CEA exchange, which makes that CCF eligible to exchange Rf traffic. Having established a connection with these servers, the SBC performs the same diameter procedures and processes it performs when configured with an IP address.

When you configure an **account-server**, you can specify the server **hostname** with an FQDN instead of an IP address. In addition, you specify the realm to use for DNS queries. Upon activation, the SBC uses DNS to:

- Identify one or more IP addresses that correspond to your FQDN.
- Utilize the port provided in the response.

### Note:

If there is no port or port 0 in the response, the SBC contacts the CCF via the port you configure in your **account-server**.

- Utilize DNS-provided TTL to start the timer used to determine when to re-send an SRV query.
- Utilize DNS-provided priority and weight to determine the order with which to send ACR traffic.

### Note:

If there is no priority or weight in the DNS response, the SBC uses round robin to define the order it uses to contact CCFs.

- Provide dynamic updates to CCF servers, and perform CCF addition or deletion.
- Achieve runtime scaling of CCF servers without additional configuration.

Ensuing SBC behavior is dependent on the DNS response:

- Single IP address received—Priority is irrelevant and the SBC simply uses the address provided as the only CCF target.
- Multiple IP addresses received—The receipt of multiple addresses makes multiple CCFs available for operations without configuration changes. The SBC creates a table of CCF resolutions, including DNS priority and weightage, and creates a target list. It then creates TCP connections, performs CER/CEA exchanges with all IP addresses, and routes ACRs to CCFs using the established order.
- Error/No Response—If the SBC receives an error response or no response to the SRV-query, it starts an internal DNS retry timer before it attempts to contact the servers. Also, if it finds the primary DNS Server is down, the SBC retries using your configured secondary DNS Server.
- TTL below 30 secs—If the SBC receives a TTL that is less than 30 secs for any IP address, it uses 30 seconds as the TTL. This ensures that the system does not become overloaded by an incorrect configuration.
- Zero weightage—The SBC complies with RFC 2873 by ignoring any resolutions that include a weight of zero.

If the SBC receives 3002, 3004 or 4002 error response codes from the CCF, it retries sending the ACR.

The SBC provides traffic statistics on all the IP addresses resolved against an FQDN for both the primary and secondary pools.

### Traps and Alarms

For error responses received against accounting or non-accounting requests from the CCF, including CER and DWR as well as ACR issues, the SBC issues SNMP traps and raises local alarms. Examples of these errors include determining the ACR/AVP format or content is malformed or unsupported. Examples of the applicable alarms are presented below.

ID	Task	Severity	First Occurred	Last
327708	3029	5	2021-11-16 10:31:18	2021-11-16 10:31:18
Count		Description		
1	Diameter Accounting Server lost connection!!!			
327709	3029	5	2021-11-16 10:33:24	2021-11-16 10:33:24
Count		Description		
1	Diameter Accounting Server Returned Error Result Code  10.196.2.7:3869-3002			

The applicable Traps, within ap-diameter.mib, include apDiameterSrvrErrorResultTrap (1.3.6.1.4.1.9148.3.13.1.2.2.0.5) and apDiameterSrvrSuccessResultTrap (1.3.6.1.4.1.9148.3.13.1.2.2.0.6).

### Configuration that Applies to FQDN CCFs

Key configuration on the **account-config** includes:

- The **dns-realm** parameter specifies the realm you use for resolving CCF FQDNs. This realm needs a network-interface with appropriate DNS configuration.
- Enabling the use of affinity for CCF sessions  
The **maintain-ccf-affinity** parameter enables the SBC to establish CCF affinity for ACR sessions, simplifying the reconciliation of ACRs by keeping associated records on the same CCF. Affinity applies to CCFs that you configure with either FQDN and IP address. For FQDN, the SBC still uses the mechanisms described above to determine the first access to a CCF. For determining traffic targets after the first access, the SBC prioritizes affinity over pool membership and DNS priority/weightage.

To support affinity, the SBC keeps a mapping between CCF and ACR sessions so that it sends all new ACRs for an existing session to the same CCF. The SBC breaks affinity when a selected CCF goes down or is removed from the DNS response.

- The **next-priority-selection-interval** parameter, which specifies in minutes how long the system waits after experiencing an overload scenario before it refers to the next priority.
- The **send-disconnect-peer-msg** parameter, which enables the system to send a DPR to the CCF before disconnecting from the CCF.
- The **strategy** parameter specifies how to select from a pool's CCF servers to distribute CCF traffic. This configuration applies to FQDN CCFs when the DNS response does not include priority/weight.

Key configuration on the **account-server** includes:

- The **hostname** parameter specifies the FQDN you use to fetch DNS resolution of your pool's CCF servers.
- The **fqdn-pool-type** parameter specifies whether the pool established by the DNS resolution is the primary or secondary pool of CCF servers.

## Handling Multiple CCFs

When a DNS response includes multiple CCFs as potential targets, the SBC uses a selection procedure based on your configuration, the DNS response, and current traffic conditions.

When configuring for FQDN-resolved CCF access order, you begin with determining whether you want to establish a primary and a secondary pool of servers and, if so, which FQDN is primary. This configuration establishes the first criteria for determining access order. The process of checking all potential resolutions begins with checking the resolutions from the primary **account-server**. If the system does not reach a CCF after that, it performs the same process using the secondary **account-server**.

When selecting from a pool, the SBC first refers to DNS server priority to determine the access order. The lower the priority number, the earlier the CCF appears in the list. Having established an order based on priority, the SBC then refines that order using IP address. Specifically, the SBC sorts servers that have the same priority based on the returned IP addressing. In this case, the system selects the lowest IP address in the resolution and attempts to reach that one first. If there is no response, the system tries the next lowest IP address until it has attempted every resolution.

Having identified server priority from DNS, the SBC proceeds with forwarding call-generated ACR signaling sequences with the group of highest priority servers only. The SBC uses weight to establish a round-robin method of selecting CCFs for call-generated ACR sequences from the highest priority list until it has attempted to reach all CCFs in that list. If there are no highest priority CCFs available, the SBC starts using CCFs from the next highest priority list.



The system only moves to the next priority group when all CCFs in the first priority group are down or have reached their acr buffer thresholds.

The SBC also uses weight to determine how many calls it can send to a given CCF within a single call session cycle. A call session cycle is defined as reaching the number of calls equal to the sum of all CCF weights. The system uses weight to determine the number of calls it can send to a CCF during that call cycle. The system selects each CCF of the same priority in round robin, and removes each CCF from the cycle when they reach their weight. The cycle ends when each CCF has handled its maximum. Regardless of how many calls may still be active, the system restarts the cycle once it has sent the lowest weight CCF its maximum number of calls.

If, at any point in the call session cycle, the system finds all CCFs busy, based on buffer usage, it begins to use the next highest priority group. This is also true for the secondary pool. When triggered by buffer usage by the entire primary pool, the system begins to use the highest priority group in the secondary pool. In addition, the system moves on to the secondary pool if it finds all CCFs in the primary unavailable.

### Buffer Overflow Scenario

If the SBC determines that configured buffer limits are exhausted, it starts routing traffic to lower priority or secondary pool CCFs to avoid buffer overflow.

Three configurations under **account-config** specify this behavior:

- **acr-buffer-upper-threshold**— Indicates the percentage of buffer usage beyond which the SBC routes new call sessions to alternate CCFs.
- **next-priority-selection-interval**— When buffer usage has exceeded the upper threshold, the system starts this timer. When the timer expires, the system checks buffer usage again. If buffer usage still exceeds the threshold, the system changes its selection criteria to include the next lower priority CCFs or, if they are all in use, CCFs from the secondary-pool.
- **acr-buffer-lower-threshold**— Indicates the percentage of buffer usage that triggers the SBC to start using that CCF again.

When buffer usage exceeds your **acr-buffer-upper-threshold** value, the SBC:

1. Sends an SNMP trap and raises an alarm with information about the current usage of the ACRq along with the configured lower and upper threshold. The applicable alarm, named DIAM ACCT BUFFER THRESHOLD EXCEED, appears as follows with the ID a.

```

1 alarms to show
ID          Task      Severity      First Occurred      Last
Occurred
327738     3029        6             2021-11-16 10:31:18      2021-11-16
10:31:18
Count      Description
1          Buffer Usage (90%) hit Upper Threshold Limit for Diameter
Accounting buffer!!!

```

The applicable traps, within ap-diameter.mib, include apAcctMsgQueueUpperThresholdTrap (1.3.6.1.4.1.9148.3.13.1.2.2.0.7) and apAcctMsgQueueUpperThresholdClearTrap (1.3.6.1.4.1.9148.3.13.1.2.2.0.7).

2. Starts routing calls to the CCFs from the next lower priority and continues routing existing sessions to the CCFs already assigned to them.
3. If the next lower priority CCFs are busy, the SBC selects CCFs with the priority below that for new calls.
4. If all priority CCFs are busy, the SBC selects CCFs from the secondary pool for all new sessions.
5. Continues using lower priority, and any secondary pool CCFs until buffer usage becomes equal or less than your **acr-buffer-lower-threshold** value.
6. Re-starts the **next-priority-selection-interval** timer each time buffer usage does not recover.  
On the second cycle through the **next-priority-selection-interval**, the SBC checks whether any of the highest priority CCFs are no longer servicing any sessions. If so, the system considers that (or those) CCFs available for service again, and places them at the top of the new session target list.

When buffer usage recovers, the system completes all sessions on existing CCFs and restarts assigning new sessions to the highest priority CCFs available in the primary pool.



**Note:**

On expiry of usageCheck timer, SBC restarts the timer and then, instead of directly going for further lower priority, the system checks if any of the higher priority CCFs are available.  
Furthermore, the SBC checks if outstanding ACRs of all the CCFs of any priority is zero and CCFs are eligible then SBC shall consider it as ready to serve.

The table below presents an example of a CCF distribution list.

DnsResult(Primary)					DnsResult(Secondary)				
CCF Number	hostname	port	Priority	Weightage	CCF Number	hostname	port	Priority	Weightage
CCF1	10.196.0.13	3868	1	2	CCF11	10.196.0.43	3868	1	2
CCF2	10.196.0.14	3868	1	3	CCF12	10.196.0.44	3868	1	3
CCF3	10.196.0.15	3868	1	6	CCF13	10.196.0.45	3868	1	6
CCF4	10.196.0.16	3868	1	9	CCF14	10.196.0.46	3868	1	9
CCF5	10.196.0.21	3868	2	30	CCF15	10.196.0.51	3868	2	30
CCF6	10.196.0.22	3868	2	60	CCF16	10.196.0.52	3868	2	60
CCF7	10.196.0.31	3868	3	6	CCF17	10.196.0.61	3868	3	6
CCF8	10.196.0.32	3868	3	9	CCF18	10.196.0.62	3868	3	9
CCF9	10.196.0.33	3868	3	12	CCF19	10.196.0.63	3868	3	12

Having received resolution, the SBC routes the traffic in the CCFs primary pool with priority 1, which includes CCF1 to CCF4. If the SBC finds buffer usage has reached the upper threshold value, it starts selecting CCF5 and CCF6 for new sessions, while routing the existing sessions to CCF1 through CCF4.

Having cycled through CCF1 to CCF6, and after the usageCheck timer has expired, the SBC checks whether buffer usage has recovered:

- If CCF1 to CCF4 have no outstanding request, the system routes ensuing sessions to CCF1 to CCF4.
- If CCF1 to CCF4 still have outstanding requests, the system starts routing the traffic to CCF7 to CCF9.

If CCF1 to CCF9 are in use, and the timer has expired, the SBC attempts to use CCF1 to CCF4 again. If they are still busy, the system tries CCF5 and CCF6. If they are also busy, the SBC starts selecting from the secondary pool, specifically CCF11 to CCF14.

The SBC continues to monitor buffer usage, returning to the highest priority CCFs in the primary pool when it detects that usage has recovered. At this point, the SBC stops the usageCheck timer, sends an SNMP clear trap and clears the alarm.

### Target List Updation

The SBC updates its CCF target list on a per-FQDN basis while minimizing DPRs and maintaining affinity when there is a:

- DNS cache refresh
- ACLI configuration changes

DNS refresh changes include:

- IP Address Added—The system assigns the new address to a specific pool, connects with CCF, and routes new call sessions to newly added IP also based on its priority and weight.
- IP Address Removed—The system stops sending new ACRs to the address and waits for ACAs to return until its **acr-retry-interval** expires. When it receives all the ACAs or the timer expires, the system sends DPR and disconnects the TCP connection.  
The system also ends any affinity processing for this CCF.
- Port changes to an IP Address—The system responds to this as if the applicable IP address was removed.
- Priority/Weight change—The system routes new call sessions based on modified priority without any impact on live sessions.

Configuration change impacts include:

- Disabled **account-config** —The system stops making DNS queries, and tears down all connections by sending a DPR (without checking the status of any outstanding ACRs).
- Primary Pool Added—This equates to enabling the **account-config**.
- Secondary Pool Added—You can only add a secondary pool if you have already configured the primary. In this scenario, the system makes the DNS query and sets up the secondary pool list
- Secondary Pool deleted—The system responds to this as if you have removed all secondary pool IP addresses.

 **Note:**

You cannot remove a primary pool.

- FQDN changed—The system makes a DNS query and gets the DNS result. Based on DNS result, the system compares the existing and the new lists and performs the same procedures as when an IP address is added or removed.
- Pool Type changed—The system treats this scenario as if there was an FQDN change.
- Other than FQDN changed—The system maintains CCF affinity and does not issue any DPRs.

### DPR/DPA Support

The SBC supports transmission and reception of DPRs, which confirm disconnects and disables retries. DPR/DPA processing includes:

- The CCF sends the DPR—The system replies with a DPA. It then removes any affinity mapping and routes any outstanding ACRs to alternate CCFs. If there is an FQDN refresh for this CCF after a TTL, the system reconnects to it.
- The SBC sends the DPR—The system waits for all outstanding ACAs, based on the maximum retries. Assuming you have enabled the **send-disconnect-peer-msg** parameter, the system then removes any affinity mapping and routes outstanding ACRs to the next CCF.

 **Note:**

The system also performs this procedure when you have configured the **account-server** with an IP address.

If you have configure the **account-server** with an IP address, the system responds to DPRs from the CCF by:

- Responding with a DPA
- Disconnecting the TCP connection with CCF
- Removing any affinity mapping
- Starting the **restart-delay** per the **account-server** configuration

At this point, you can remove the CCF from the ACLI., otherwise the system tries to reconnect to that CCF when the timer expires.

## Accounting Traffic and Server Statistics

Use the **show accounting** command to monitor the status and observe traffic statistics of your account servers.

The syntax for the **show accounting** command follows.

```
show accounting [<IPPort> | All] | [connections] | [ servers ]
```

Command arguments refine the output to address more specific detail, including:

- <ipaddress:port>—Reports on the server you specify with IP address and port. Specify these servers using the syntax <ipaddress:port>.
- all—Reports on all accounting servers
- connections—Shows connections for all accounting servers
- servers—Reports on servers when resolved using DNS and connection details for all Accounting Servers per pool

The output below presents the standard traffic data generated when using no argument, the **ipport** argument and the **all** argument.

```
SBC01# show accounting
07:23:40-198
Accounting Status:
```

	-- Period --			----- Lifetime ----		
	Active	High	Total	Total	PerMax	High
Request Queue	0	0	0	0	0	0
Client Trans	0	0	0	0	0	0
Server Trans	0	0	0	0	0	0
Sockets	2	2	0	2	2	2
Connections	0	0	0	0	0	0

```
Total Accounting Server Stats:
```

	----Lifetime ----		
	Recent	Total	PerMax
Msgs Queued	0	0	0
Msgs Discarded	0	0	0
Wait Queue Asks	0	0	0
Wait Queue Pops	0	0	0
Msgs Reclaimed	0	0	0
Msgs Sent	0	0	0
Msg Send Failed	0	0	0
Msgs ReSent	0	0	0
Msgs Rcvd	0	0	0
Msgs Processed	0	0	0
Conn Timeouts	13	20880	7
Bad State Drops	0	0	0
Bad Type Drops	0	0	0
Bad Id Drops	0	0	0
Auth Failed Drops	0	0	0
Invalid peer Msgs	0	0	0
Protocol errors	0	0	0
Transient Failures	0	0	0
Permanent Failures	0	0	0

```
Total Accounting Server Diameter msg Stats:
```

	----Lifetime ----		
	Recent	Total	PerMax
CER Sent	0	0	0
CEA Success	0	0	0
CEA Errors	0	0	0
ACR Sent	0	0	0
ACA Success	0	0	0
ACA Errors	0	0	0
DWR Sent	0	0	0

```
DWA Success          0          0          0
DWA Errors           0          0          0
DWR Rcvd             0          0          0
DWA Sent Success     0          0          0
DWA Sent Errors      0          0          0
```

Total Accounting Server SIPD to RADD msg Stats:

```
-----Lifetime-----
          Recent      Total      PerMax
Acct Type Start         0         0         0
Acct Type Stop          0         0         0
Acct Type Interim       0         0         0
Acct Type Event         0         0         0
```

Server 1:

```
-----10.196.2.7:3869-----
```

```
Connection state: UNAVAIL
Socket FD: -1
Reconnect attempt in 6s
Pending: 0 of 255
Current RTT: 0 ms(before failure)
      Local IPPort      Remote IPPort      Socket State
      10.196.165.97:0   10.196.2.7:3869   INITIAL
```

Server 2:

```
-----10.196.165.86:3868-----
```

```
Connection state: UNAVAIL
Socket FD: -1
Reconnect attempt in 18s
Pending: 0 of 255
Current RTT: 0 ms(before failure)
      Local IPPort      Remote IPPort      Socket State
      10.196.165.97:0   10.196.165.86:3868 INITIAL
```

The system also displays DPR and DPA traffic on a server-specific basis within the **show accounting all**, **show accounting connections**, and **show accounting <IPPort>** commands.

```
DPR Sent          0          0          0
DPA Success        0          0          0
DPA Errors         0          0          0
DPR Rcvd           0          0          0
DPA Sent Success   0          0          0
DPA Sent Errors    0          0          0
```

You use the **servers** argument to display those servers resolved by DNS, based on whether they reside in the primary or secondary pool. This command displays the servers based on IP resolution and includes DNS detail including priority and weightage.

```
SBC01# show accounting servers
07:23:40-198
FQDN: primary.oracle.com
Type: Primary
Last Resolved TimeStamp: Nov 16 08:31:01.521
```

Min TTL : 120 secs

Server 1:

-----10.196.2.7:3869 -----

Connection state: UNAVAIL

Socket FD: -1

Reconnect attempt in 6s

Pending: 0 of 255

Current RTT: 0 ms(before failure)

Priority: 1

Weightage: 10

TTL: 120 secs

OutStanding ACR:10

Is Marked for Delete : True/False

Local IPPort	Remote IPPort	Socket State
10.196.165.97:0	10.196.2.7:3869	INITIAL

Server 2:

-----10.196.165.86:3868 -----

Connection state: UNAVAIL

Socket FD:-1

Reconnect attempt in 18s

Pending: 0 of 255

Current RTT: 0 ms(before failure)

Priority: 1

Weightage: 10

TTL: 120 secs

OutStanding ACR: 10

Is Marked for Delete : True/False

Local IPPort	Remote IPPort	Socket State
10.196.165.97:0	10.196.165.86:3868	INITIAL

FQDN: secondary.oracle.com

Type: Secondary

Last Resolved TimeStamp: Nov 16 08:31:01.521

Min TTL : 120 secs

Server 1:

-----10.196.2.7:3869 -----

Connection state: UNAVAIL

Socket FD: -1

Reconnect attempt in 6s

Pending: 0 of 255

Current RTT: 0 ms(before failure)

Priority: 1

Weightage: 10

TTL: 120 secs

OutStanding ACR: 10

Is Marked for Delete : True/False

Local IPPort	Remote IPPort	Socket State
10.196.165.97:0	10.196.2.7:3869	INITIAL

Server 2:

-----10.196.165.86:3868 -----

Connection state: UNAVAIL

```

Socket FD: -1
Reconnect attempt in 18s
Pending: 0 of 255
Current RTT: 0 ms(before failure)
Priority: 1
Weightage: 10
TTL: 120 secs
OutStanding ACR: 10
Is Marked for Delete : True/False
  Local IPPort      Remote IPPort      Socket State
  10.196.165.97:0   10.196.165.86:3868  INITIAL

```

When using DNS to resolve CCF servers, you can use the following additional commands can help you determine DNS status, traffic and resolutions, within the context of the DNS server operating as an Edge Application Server (EAS)

- `show dns cache-entry-eas`
- `show dns stats-eas`
- `reset dns-eas`

## Configuring Diameter-based Accounting

Diameter-based Rf accounting relies on many of the same configuration elements used for RADIUS based accounting. The following two sections explain how to configure both the **account-config** and **account-servers** configuration elements. In addition, you must ensure that accounting is enabled for each realm where you want it to occur. The **accounting-enable** parameter in the realm-config is enabled by default.

### Configure the Global Diameter-based Accounting (Rf) Features

To configure the global Diameter-based accounting (Rf) features in the account-config:

1. In Superuser mode, type **configure terminal** and press Enter.

```
ORACLE# configure terminal
```

2. Type **session-router** and press Enter.

```
ORACLE(configure)# session-router
```

3. Type **account-config** and press Enter.

```
ORACLE(session-router)# account-config
ORACLE(account-config)#
```

4. **hostname**—The hostname for this system. This value must be set to “localhost” or the accounting configuration does not work properly.
5. **port**—Enter 3868 for the RFC-recommended Diameter port number. You may enter a different port number.
  - minimum: 1025
  - maximum: 65535



6. **strategy**—Set the strategy used to select the accounting server which the SBC sends accounting messages. The following are the available strategies:
  - **hunt**—Selects accounting servers in the order in which they are listed. If the first accounting server is online, working, and has not exceeded any of the defined constraints, all traffic is sent to it. Otherwise the second accounting server is selected. If the first and second accounting servers are offline or exceed any defined constraints, the third accounting server is selected. And so on through the entire list of configured servers
  - **failover**—Uses the first server in the list of predefined accounting servers until a failure is received from that server. Once a failure is received, it moves to the second accounting server in the list until a failure is received. And so on through the entire list of configured servers.
  - **round robin**—Selects each accounting server in order, distributing the selection of each accounting server evenly over time.
  - **fastest round trip time**—Selects the accounting server that has the fastest round trip time (RTT) observed during transactions with the servers (sending a record and receiving an ACK).
  - **fewest pending**—Selects the accounting server that has the fewest number of unacknowledged accounting messages (that are in transit to the SBC).
7. **protocol**—Set this parameter to **diameter** to use the Rf accounting interface with a Diameter-based accounting server.
8. **state**— Enter **enabled** to use accounting on this system.
9. **dns-realm**—If using FQDN lookup of account-servers, specify the realm through which the system reaches DNS resources to resolve your FQDN(s) to IP address(es).
10. **max-msg-delay**—Retain the default value of **60** seconds or indicate the length of time in seconds that you want the SBC to continue trying to send each accounting message. During this delay, the SBC can hold a generic queue of 4096 messages.
  - Minimum: zero (0)
  - Maximum: 4294967295
11. **max-wait-failover**—Retain the default value of **100** messages or indicate the maximum number of accounting messages the SBC can store its message waiting queue for a specific accounting server, before it is considered a failover situation.

Once this value is exceeded, the SBC attempts to send its accounting messages, including its pending messages, to the next accounting server in its configured list.

  - Minimum: one (1) message
  - Maximum: 4096 messages
12. **trans-at-close**—Retain the default value of **disabled** if you do not want to defer the transmission of message information to the close of a session. Enter **enabled** if you want to defer message transmission.
  - **disabled**—The SBC transmits accounting information at the start of a session (Start), during the session (Interim), and at the close of a session (Stop). The transmitted accounting information for a single session might span a period of hours and be spread out among different storage files.

- **enabled**—Limits the number of files on the SBC used to store the accounting message information for one session. It is easiest to store the accounting information from a single session in a single storage file.
13. **generate-start**—Retain the default value **ok** if you want the ACR Start message to be generated once the SBC receives an OK message in response to an INVITE.

Other options include:

- **none**—Accounting Start message should not be generated.
  - **invite**—Accounting Start message should be generated once the SBC receives a SIP INVITE.
  - **""**—When two quotation marks are entered next to each other (empty), behavior is identical to none value.
14. **generate-interim**—Retain the default value **reinvite-response** to cause the SBC to send an Interim charging message to the accounting server.

You can select none, one, or more than one of the following values:

- **ok**—Start message is generated when the SBC receives an OK message in response to an INVITE.
  - **reinvite**—Interim message is generated when the SBC receives a SIP session reINVITE message.
  - **reinvite-response (default)**—Interim message is generated when the SBC receives a SIP session reINVITE and responds to it (for example, session connection or failure).
  - **reinvite-cancel**—Interim message is generated when the SBC receives a SIP session reINVITE, and the Reinvite is cancelled before the SBC responds to it.
  - **unsuccessful-attempt**—Interim message is generated when a SIP session set-up attempt from a preference-ordered list of next-hop destinations is unsuccessful. This can happen when a local policy lookup, LRT lookup, ENUM query response, or SIP redirect returns a preference-ordered list of next-hop destinations. The interim message contains: the destination IP address, the disconnect reason, a timestamp for the failure, and the number that was called.
15. **generate-event**—Enter one or more valid events that prompt creation of an Event record. Enclosed multiple values in parenthesis and separate by spaces.

value settings include triggering the SBC to generate an accounting message when it:

- **none**—(default)
  - **Register**—Receives a SIP REGISTER.
  - **Local-Register**—Prompts the SBC to create Event ACRs on a re-REGISTER to which it replied.
  - **message**—Receives an SMS message.
16. **intermediate-period**—Enter amount of time in seconds between generating periodic interim ACR messages during a SIP call. This parameter defaults to zero, which disables continuous Interim charging messages.
17. **vsa-id-range**—Ensure that this parameter is left blank when communicating with a Diameter-based Rf accounting server.
18. **max-acr-retries** — Retain the default value of zero (**0**) or enter the maximum number of times that the SBC can resend an ACR for a session.
- Minimum: zero (0)

- Maximum: 4
19. **acr-retry-interval** — Retain the default value of **10** seconds or enter the time in seconds for the SBC to wait before resending an ACR for a session.
    - Minimum: 5
    - Maximum: 20
  20. **acr-buffer-upper-threshold**—The upper threshold for the ACR buffer after which the SBC will select an alternate server.
    - 90 (default)
    - 0 - 100
  21. **acr-buffer-lower-threshold**—The lower threshold for the ACR buffer which, when reached, the SBC will select the primary server again.
    - 70 (default)
    - 0 - 100
  22. **maintain-ccf-affinity**—Enable affinity between ACRs and CCFs so that all ACRs within a single session are sent to the same CCF, unless it goes down.
    - Disable (default)
    - Enable
  23. **send-disconnect-peer-msg**— Enables the system to send a DPR to the CCF before disconnecting from the CCF
    - Disable (default)
    - Enable
  24. **next-priority-selection-interval**—Specifies in minutes how long the system waits after experiencing an overload scenario before it refers to the next priority. The range is 0 to 60 minutes.
  25. Save your work.

## Configure Accounting Servers

You must create one or more servers to which the SBC can send accounting messages.

1. Continuing from the previous account-config configuration, enter the account server sub-element by typing **account-servers** Enter.

```
AZALEA(account-config) # account-servers
AZALEA(account-server) #
```

2. **hostname**—Set this to the IP address or the FQDN of the Diameter-based Rf accounting server.
3. **fqdn-pooltype**—When accessing a diameter accounting server using an FQDN, specify whether the pool of servers resolved to this FQDN is the primary or secondary pool of servers with which the system performs accounting functions. If all servers resolved to the primary pool are unavailable, the system uses the secondary pool from which it accesses CCF servers.

4. **port**—Enter 3868 for the RFC-recommended Diameter port number. You may enter a different port number if desired.
  - minimum: 1025
  - maximum: 65535
5. **state**—Retain the default enabled to enable this account server or enter disabled to disable it.
6. **min-round-trip**—Retain the default 250 milliseconds or indicate the minimum round trip time of an accounting message.
  - minimum: 10 milliseconds
  - maximum: 5000 milliseconds

A round trip consists of the following:

The SBC sends an accounting message to the account server.

The account server processes this message and responds back to the SBC.

If the fastest RTT is the strategy for the account configuration, the value you enter here can be used to determine an order of preference (if all the configured account servers are responding in less than their minimum RTT).
7. **max-inactivity**—Retain the default 60 seconds or indicate the length of time in seconds that you want the SBC with pending accounting messages to wait when it has not received a valid response from the target account server.
  - minimum: 1 second
  - maximum: 300 seconds

Once this timer value is exceeded, the SBC marks the unresponsive account server as disabled in its failover scheme. When a server connection is marked as inactive, the SBC attempts to restart the connection and transfers pending messages to another queue for transmission. Accounting messages might be moved between different account servers as servers become inactive or disabled.
8. **restart-delay**—Retain the default 30 seconds or indicate the length of time in seconds you want the SBC to wait before resending messages to a disabled account server.
  - minimum: 1 second
  - maximum: 300 seconds
9. **priority**—Enter the number corresponding to the priority of this account server, for use with server prioritization. The default for this parameter is 0, meaning the prioritization feature is turned off—and that the SBC will therefore prioritize accounting servers by IP address and port.
10. **origin-realm**—Enter the realm in which the SBC communicates with the Diameter Rf accounting server.
11. **domain-name-suffix**—Enter the suffix to be appended to any Diameter FQDN or Diameter Identity used when the SBC communicates with the Diameter Rf accounting server. Your value can be any string, to which the SBC will prepend with a dot.
12. **watchdog-ka-timer**—Set this parameter to the value in seconds that the SBC waits between sending DWRs. 0 disables this feature. Valid non-zero values are 6 - 65535
13. Save your work.

## Create a Dictionary File for Decoding AVPs

You can generate an AVP dictionary from the SBC to install and use for decoding Oracle-specific Rf AVPs in messages using Wireshark. After generating this dictionary, you include it within your Wireshark deployment and configure a Wireshark resource file. This allows Wireshark to decode standalone and grouped AVPs identified with the ACME\_DIAM\_VENDOR\_ID label.

To create this dictionary, you:

1. Login to your cloud SBC.
2. Run the command **dump\_diam\_dict** from the ACLI. The system creates the file `/opt/logs/OracleSBCRF.xml`.
3. Copy the file from the SBC using SFTP.

Having generated the file, you next establish it as a Wireshark decode entity.

4. Navigate to the path where your Wireshark application is installed. On Windows, this is typically "C:\Program Files\Wireshark\diameter".
5. Open the `dictionary.xml` file, using a notepad application with Admin privileges. This file contains an assortment of content types, one of which is called an "ENTITY". The ENTITY list allows Wireshark to use decoding resources.
6. Add a new entry to the ENTITY list, using the name of your AVP file. This procedure uses the example file name `OracleSBCRF.xml`. The code block below gives an example of two items in the ENTITY list, one of which is your new entry.

```
...
<!ENTITY Custom SYSTEM "Custom.xml">
<!ENTITY OracleSBCRF SYSTEM "OracleSBCRF.xml">
...
```

7. Close this file using the following syntax at the end of the file.

```
...
&Custom;
&OracleSBCRF;
</dictionary>
```

8. Put your `OracleSBCRF.xml` file in the same directory as the "diameter" file.
9. Start or restart Wireshark.

At this point, Wireshark can decode the applicable AVPs sent within Rf interface messages.

# Additional Rf Features Alarms and Traps

## Service-Context-ID Format

The Service-Context-ID AVP (461) located in the root ACR message is formatted as follows:

```
[["extensions".]MNC.MCC.]"Release".]32260@3gpp.org
```

where

- extensions—This is operator specific information to any extensions in a service specific document. The value is configured by setting the **diam-srv-ctx-ext** parameter.
- MNC.MCC—This identifies the operator implementing the service specific document, which is used to determine the specific requirements for the operator configurable parameters. Both MNC and MCC must be specified separated by a dot(.). The value is configured by setting the **diam-srv-ctx-mnc-mcc** parameter as two integers separated by a dot. For example: 012.310
- Release—This indicates the 3GPP Release the service specific document is based upon e.g. 6 for Release 6. The value is configured by setting the **diam-srv-ctx-rel** parameter with valid values are >=1.

 **Note:**

"32260@3gpp.org" is fixed.

## Acme Excluded Attribute Range

You can select certain ACME specific AVPs to include in the Rf accounting records with the **diam-acme-attr-id-range** parameter. If this parameter is configured with one or more values, then all other valid Acme-specific AVPs, by number, are excluded. If by configuration, the SBC will exclude one (or more) individual ACME attributes, there will be no effect. If by configuration an Acme-specific attribute number that refers to a group is excluded, the SBC removes the complete grouped AVP from the ACR message.

Consider:

- Acme-specific attribute 1—The grouped AVP
- Acme-specific attributes 2-35—The individual AVPs that make up the group

If you configure **diam-acme-attr-id-range 1,3-** the SBC includes all attributes in the Acme group; This configuration aims to exclude only attribute 3 but is has no effect.

If you configure **diam-acme-attr-id-range 2-**, the SBC excludes the full Acme-specific group because Acme-Packet-Specific-Extension-Rf AVP (1) was not included.

The **diam-acme-attr-id-range** parameter's syntax is as follows:

Syntax	Meaning
X-Y	include range of attribute IDs from X to Y (X and Y are included)

Syntax	Meaning
-Y	include any attribute ID <= Y
X-	include any attribute ID >= X
-	include any attribute ID
X	include attribute ID = X

## Configure Account

1. In Superuser mode, type **configure terminal** and press Enter.

```
ORACLE# configure terminal
```

2. Type **session-router** and press Enter.

```
ORACLE (configure) # session-router
```

3. Type **account-config** and press Enter.

```
ORACLE (session-router) # account-config  
ORACLE (account-config) #
```

4. **diam-srv-ctx-ext**—Enter the extension portion of the Service-Context-ID AVP value. This value can be any string.
5. **diam-srv-ctx-mnc-mcc**—Enter the MNC.MCC portion of the Service-Context-ID AVP value. This value must follow the NUM1.NUM2 format.
6. **diam-srv-ctx-rel**—Enter the release portion of the Service-Context-ID AVP value. This value can be any number >= 1..
7. **diam-acme-attr-id-range**—Enter the range of Acme-specific AVPs to include in ACR messages. Leaving this parameter blank or configured with a - includes all AVPs.
8. Type **done** to save your work.

## SNMP Trap Behavior

The SBC sends an SNMP trap (apDiameterSrvrErrorResult) upon a CCF returning an error-containing ACA. See the list of four errors (3002, 3004, 4002, 5012) which generate traps in the [Alarms](#) section. The frequency at which subsequent traps are sent is based upon configuring the **diam result code trap grade period** option configured in the account config.

When the SBC has sent a trap after receiving a bad ACA, it goes into an error state. The SBC waits one grace period before checking if it is still in an error state. If the state has not switched from errored back to pending, the SBC sends another error trap, after that first grace period ends (counting from the initial error) and then after the next error message is received.

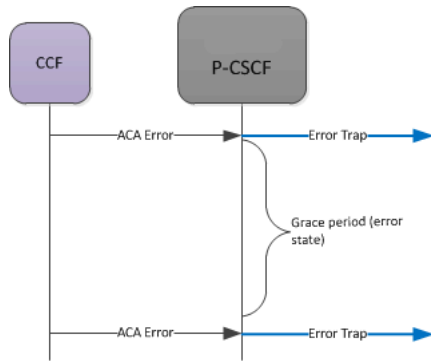

If the CCF returns a successful message, the grace start in a pending state. When this second timer expires (pending no more errors or additional successes), on the next successful ACA, a success trap is sent.

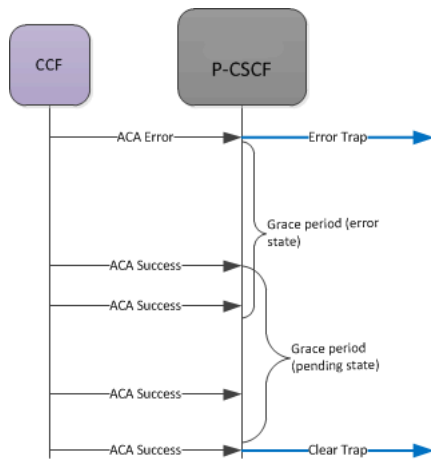

If, while in the pending grace period an ACA error is received, the SBC immediately sends an error trap, and begins the error state again. It also starts counting the initial grace period time again.

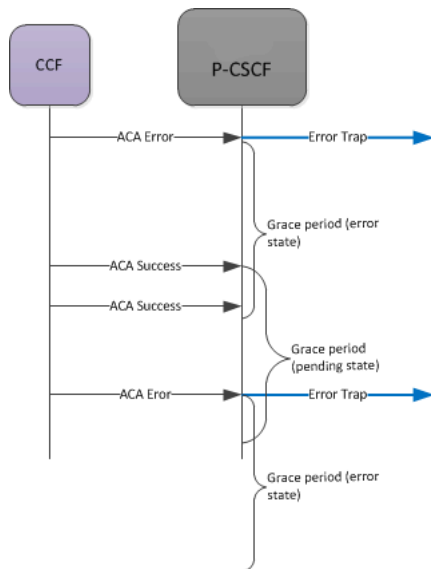



## Alarms

A MINOR non health affecting Diameter Accounting Server Error alarm will be generated when one of the following Result Codes is received:

- 3002 (DIAMETER\_UNABLE\_TO\_DELIVER)
- 3004 (DIAMETER\_TOO\_BUSY)
- 4002 (DIAMETER\_OUT\_OF\_SPACE)
- 5012 (DIAMETER\_UNABLE\_TO\_COMPLY)

The alarm is cleared when a success (2XXX) code is received.

The rules for setting state of the failed server alarm are the same as the grace period rules described in the [SNMP Trap Behavior](#) section.

For example:

```
327703 835778540      5      2012-03-13 13:03:34      2012-03-13
13:03:34
Count  Description
1      Diameter Accounting Server Returned Error Result Code|
172.30.0.135:3869-5012|172.30.69.211:3868-3002
```

## SNMP MIBs and Traps

### ApDiamResultCode Textual Convention

```
ApDiamResultCode ::= TEXTUAL-CONVENTION
    STATUS          current
    DESCRIPTION
        "The Result-Code AVP (268) value
        RFC 3588, 7.1. Result-Code AVP"
    SYNTAX          INTEGER {
        diameterMultiRoundAuth(1001),
        diameterSuccess(2001),
        diameterLimitedSuccess(2002),
        diameterCommandUnsupported(3001),
        diameterUnableToDeliver(3002),
        diameterRealmNotServed(3003),
        diameterTooBusy(3004),
        diameterLoopDetected(3005),
        diameterRedirectIndicatoion(3006),
        diameterApplicationUnsupported(3007),
        diameterInvalidHdrBits(3008),
        diameterInvalidAvpBits(3009),
        diameterUnknownPeer(3010),
        diameterAuthenticationRejected(4001),
        diameterOutOfSpace(4002),
        electionLost(4003),
        diameterAvpUnsupported(5001),
        diameterUnknownSessionId(5002),
```

```

        diameterAuthoriszationRejected(5003),
        diameterInvalidAvpValue(5004),
        diameterMissingAvp(5005),
        diameterResourcesExceeded(5006),
        diameterContradictingAvps(5007),
        diameterAvpNotAllowed(5008),
        diameterAvpTooManyTimes(5009),
        diameterNoCommonApplication(5010),
        diameterUnsupportedVersion(5011),
        diameterUnableToComply(5012),
        diameterInvalidBitInHeader(5013),
        diameterInvalidAvpLength(5014),
        diameterInvalidMessageLength(5015),
        diameterInvalidAvpBitCombo(5016),
        diameterNoCommonSecurity(5017)
    }
}

```

## apDiameterSrvrErrorResultTrap

```

apDiameterSrvrErrorResultTrap      NOTIFICATION-TYPE
OBJECTS                            { apDiamAcctSrvrHostName,
                                   apDiamAcctSrvrIPPort,
                                   apDiamAcctSrvrOriginRealm,
                                   apDiamAcctSrvrOriginHost,
                                   apDiamAcctSrvrTransportType,
                                   apDiameterResultCode
                                   }
STATUS                              current
DESCRIPTION
    " The trap can be generated when the Diameter Server
      returns 3xxx (Protocol Errors), 4xxx (Transient Failures), or
      5xxx (Permanent Failure) Result-Code AVP (268)"
 ::= { apDiamNotifications 5 }

```

## apDiameterSrvrSuccessResultTrap

```

apDiameterSrvrSuccessResultTrap    NOTIFICATION-TYPE
OBJECTS                            { apDiamAcctSrvrHostName,
                                   apDiamAcctSrvrIPPort,
                                   apDiamAcctSrvrOriginRealm,
                                   apDiamAcctSrvrOriginHost,
                                   apDiamAcctSrvrTransportType,
                                   apDiameterResultCode
                                   }
STATUS                              current
DESCRIPTION
    " The trap can be generated when the Diameter Server
      returns a 2xxx (Success) Result-Code AVP (268)
      after an error result"
 ::= { apDiamNotifications 6 }

```

## apDiamACCTResultObjectsGroup Object Group

```

apDiamACCTResultObjectsGroup OBJECT-GROUP
  OBJECTS {
    apDiameterResultCode
  }
  STATUS current
  DESCRIPTION
  "A collection of mib objects accessible only to traps."
  ::= { apDiamNotificationGroups 3 }

```

## apDiamACCTResultNotificationsGroup Notification Group

```

apDiamACCTResultNotificationsGroup NOTIFICATION-GROUP
  NOTIFICATIONS {
    apDiameterSrvrErrorResultTrap,
    apDiameterSrvrSuccessResultTrap
  }
  STATUS current
  DESCRIPTION
  "A collection of traps defined for ACCT Result Code."
  ::= { apDiamNotificationGroups 4 }

```

## SNMP Varbind Definitions

- apDiamAcctSrvrHostName—contains the account-server hostname.
- apDiamAcctSrvrIPPort—This object contains the account-server IP address and port number in the following format:  
XXX.XXX.XXX.XXX:PORT
- apDiamAcctSrvrOriginRealm—contains the origin realm, which is a concatenation of the account-server realm and suffix in the following format:  
[ account-server realm][ account-server suffix]
- apDiamAcctSrvrOriginHostName—contains the origin host name, which is a concatenation of the accounting-config host name, account-server realm and account-server suffix in the following format:  
[accounting-config host name].[ account-server realm][ account-server suffix]
- apDiamAcctSrvrTransportType—contains the transport type.
- apDiameterResultCode—contains the Result-Code AVP (268) value as defined in RFC 3588, 7.1. Result-Code AVP

# Diameter Rf Charging Buffering and Storage

## About Buffering

Diameter Rf Charging, Buffering, and Storage enables the SBC to buffer all accounting requests (ACR) in memory for a configurable number of ACRs. The buffer holds a minimum of 15 minutes of ACRs under busy-hour load conditions. For example, based

on intended traffic, the buffer would hold 54 calls-per-second which equals approximately 150,000 records. The SBC sends an SNMP trap when accounting records begin to drop from the buffer due to an overflow condition. Subsequently, a clearing SNMP trap is sent once the fault condition is removed.

## About Storage

The SBC maintains storage to temporarily store accounting records to a charging collection function (CCF) link, in case of a failure or congestion exists on the SBC. In this scenario, the SBC can store a minimum of 3 days-worth of accounting records. All ACRs can remain in storage for a configurable amount of time, and for a minimum of 3 days under normal traffic-load conditions.

There are two configurable options for storing ACRs:

- Store all ACRs generated by the SBC
- No ACRs in storage

## Monitoring Storage Space

Disk storage space monitoring can be done on the total drive, or by disk partition. You can monitor storage space using the one of the following methods:

- Command line interface (CLI)
- SNMP management information base (MIB)
- Historical data records (HDR)

## ACLI Instructions and Examples

To configure Diameter Rf buffering and storage size:

1. In Superuser mode, type `configure terminal` and press Enter.

```
ORACLE# configure terminal
```

2. Type `session-router` and press Enter.

```
ORACLE (configure) # session-router  
ORACLE (session-router) #
```

3. Type `account-config` and press Enter.

```
ORACLE (session-router) # account-config  
ORACLE (account-config) #
```

- If you are adding support for this feature to a pre-existing configuration, then you must select (using the ACLI `select` command) the configuration that you want to edit.
4. **diam-attr-id-range**—Comma delimited range of accounting attributes to include in DIAMETER Rf accounting records (blank field means feature turned off and all attributes included).

5. **msg-queue-size**—Enter the message queue size. **This parameter applies to both RADIUS and Diameter accounting interfaces.** The valid range is 5000 - 150000. The default value is 5000.
6. Save your work.

## SNMP

SNMP traps will be sent to the configured management system(s) when accounting records begin to drop due to an overflow condition and when this fault condition is removed:

- apAcctMsgQueueFullTrap will be sent when accounting records begin to drop due to an overflow condition and all accounting servers are down

- apAcctMsgQueueFullClearTrap will be sent when the apAcctMsgQueueFullTrap fault condition is cleared

The following varbinds are defined for the above traps

- apAcctMsgQueueCurrent

The current measured percentage value of space available

- apAcctMsgQueueMinorThreshold

The current configured minor threshold value

- apAcctMsgQueueMajorThreshold

The current configured major threshold value

- apAcctMsgQueueCriticalThreshold

The current configured critical threshold value.

## DIAMETER Rf Charging Failure & Recovery Detection

The SBC can detect and report when the DIAMETER Rf interface has failed and when it has recovered.

- Transport failure detection—The SBC sends SNMP traps to the configured management systems when a Diameter Rf Charging transport failure has been detected. If multiple transport failures have been detected, an SNMP trap is sent for each failure.
- Transport recovery detection—When a Diameter Rf Charging CCF has recovered and is back in service, an SNMP trap notification is sent by the SBC to the configured management systems notifying of that event.

## Associated Traps

SNMP traps will be sent to the configured management system(s) when a transport failure or recovery is detected:

- apDiameterAcctSvrDownTrap will be sent if SBC can't connect to a configured Diameter Accounting Server after reboot

- apDiameterAcctSvrDownTrap will be sent if SBC loses connection to a configured Diameter Accounting Server during normal operations
- apDiameterAcctSvrUpTrap will be sent if SBC regains connection to a configured Diameter Accounting Server after a previous connection loss

The following varbinds are defined for the above traps:

- apDiamAcctSvrHostName—This object will contain account-server hostname.
- apDiamAcctSvrIPPort—This object will contain account-server IP address (which is the same as the hostname since we don't support FQDN for the account-server hostname) and port number in the following format: XXX.XXX.XXX.XXX:PORT.
- apDiamAcctSvrOriginRealm—This object will contain the origin realm, which is a concatenation of the account-server realm and suffix in the following format:

[ account-server realm][ account-server suffix]

- apDiamAcctSvrOriginHostName—This object will contain the origin host name, which is a concatenation of the accounting-config host name, account-server realm and account-server suffix in the following format:

[accounting-config host name].[ account-server realm][ account-server suffix]

- apDiamAcctSvrTransportType—This object will contain the transport type. At this time only the TCP transport type is supported

# A

## RADIUS Dictionary Reference

For RADIUS dictionary content, refer to the radius file in this version's documentation library.

# B

## Local CDR Table Layouts

This appendix includes three example tables that show the fully inclusive layout of local CDR files for the most common CDR records. You can also create similar layout outputs based on your own configuration and traffic with the `dump_csv_format` command if you use the functions explained in the [RADIUS CDR Content Control](#) section.

 **Note:**

The Acme-CDR-Sequence-Number, Vendor ID 59, appears in local CDR files when both file-output is enabled and an account server is configured.

### Local CDR Start Record (RADIUS)

The following table contains the local CDR layout, inclusive of all VSA data for a start record, when RADIUS is selected as the account protocol.

**Table B-1 Local CDR Start Record (RADIUS)**

CSV Position	Attribute Name	Vendor	CDR Number
1	Accounting Status	none	40
2	NAS IP Address	none	4
3	NAS Port	none	5
4	Accounting Session ID	none	44
5	Ingress Session ID	ACME	3
6	Egress Session ID	ACME	4
7	Session Protocol Type	ACME	43
8	Session-Forked-Call-Id	ACME	171
9	Generic ID	ACME	40
10	Calling Station ID	none	31
11	Called Station ID	none	30
12	Cisco Setup Time	CISCO	25
13	Cisco Connect Time	CISCO	28
14	Egress Network Interface ID	ACME	139
15	Egress Vlan Tag Value	ACME	140
16	Ingress Network Interface ID	ACME	137
17	Ingress Vlan Tag Value	ACME	138
18	Egress Realm	ACME	42
19	Ingress Realm	ACME	41
20	Flow Identifier	ACME	1
21	Flow Type	ACME	2



**Table B-1 (Cont.) Local CDR Start Record (RADIUS)**

<b>CSV Position</b>	<b>Attribute Name</b>	<b>Vendor</b>	<b>CDR Number</b>
22	Flow Input Realm	ACME	10
23	Flow Input Src Addr	ACME	11
24	Flow Input Src Port	ACME	12
25	Flow Input Dest Address	ACME	13
26	Flow Input Dest Port	ACME	14
27	Flow Output Realm	ACME	20
28	Flow Output Src Address	ACME	21
29	Flow Output Src Port	ACME	22
30	Flow Output Dest Addr	ACME	23
31	Flow Output Dest Port	ACME	24
32	Flow Identifier	ACME	78
33	Flow Type	ACME	79
34	Flow Input Realm	ACME	80
35	Flow Input Src Addr	ACME	81
36	Flow Input Src Port	ACME	82
37	Flow Input Dest Address	ACME	83
38	Flow Input Dest Port	ACME	84
39	Flow Output Realm	ACME	85
40	Flow Output Src Address	ACME	86
41	Flow Output Src Port	ACME	87
42	Flow Output Dest Addr	ACME	88
43	Flow Output Dest Port	ACME	89
44	Flow Identifier	ACME	90
45	Flow Type	ACME	91
46	Flow Input Realm	ACME	92
47	Flow Input Src Addr	ACME	93
48	Flow Input Src Port	ACME	94
49	Flow Input Dest Address	ACME	95
50	Flow Input Dest Port	ACME	96
51	Flow Output Realm	ACME	97
52	Flow Output Src Address	ACME	98
53	Flow Output Src Port	ACME	99
54	Flow Output Dest Addr	ACME	100
55	Flow Output Dest Port	ACME	101
56	Flow Identifier	ACME	112
57	Flow Type	ACME	113
58	Flow Input Realm	ACME	114
59	Flow Input Src Addr	ACME	115
60	Flow Input Src Port	ACME	116
61	Flow Input Dest Address	ACME	117
62	Flow Input Dest Port	ACME	118
63	Flow Output Realm	ACME	119
64	Flow Output Src Address	ACME	120

Table B-1 (Cont.) Local CDR Start Record (RADIUS)

CSV Position	Attribute Name	Vendor	CDR Number
65	Flow Output Src Port	ACME	121
66	Flow Output Dest Addr	ACME	122
67	Flow Output Dest Port	ACME	123
68	Charging Vector ICID	ACME	54
69	Charging Function Address	ACME	55
70	Firmware Version	ACME	56
71	Local timezone	ACME	57
72	Post Dial Delay (msec)	ACME	58
73	Primary routing Number	ACME	64
74	Originating Trunk Group	ACME	65
75	Terminating Trunk Group	ACME	66
76	Originating Trunk Context	ACME	67
77	Terminating Trunk Context	ACME	68
78	P Asserted ID	ACME	69
79	Ingress Local Address	ACME	74
80	Ingress Remote Address	ACME	75
81	Egress Local Address	ACME	76
82	Egress Remote Address	ACME	77
83	SIP DIVERSION	ACME	70
84	Egress Routing Number	ACME	134
85	Ingress RPH	ACME	135
86	Egress RPH	ACME	136
87	Custom VSA 200	ACME	200
88	Custom VSA 201	ACME	201
89	Custom VSA 202	ACME	202
90	Custom VSA 203	ACME	203
91	Custom VSA 204	ACME	204
92	Custom VSA 205	ACME	205
93	Custom VSA 206	ACME	206
94	Custom VSA 207	ACME	207
95	Custom VSA 208	ACME	208
96	Custom VSA 209	ACME	209
97	Custom VSA 210	ACME	210
98	Custom VSA 211	ACME	211
99	Custom VSA 212	ACME	212
100	Custom VSA 213	ACME	213
101	Custom VSA 214	ACME	214
102	Custom VSA 215	ACME	215
103	Custom VSA 216	ACME	216
104	Custom VSA 217	ACME	217
105	Custom VSA 218	ACME	218
106	Custom VSA 219	ACME	219
107	Custom VSA 220	ACME	220

**Table B-1 (Cont.) Local CDR Start Record (RADIUS)**

<b>CSV Position</b>	<b>Attribute Name</b>	<b>Vendor</b>	<b>CDR Number</b>
108	Custom VSA 221	ACME	221
109	Custom VSA 222	ACME	222
110	Custom VSA 223	ACME	223
111	Custom VSA 224	ACME	224
112	Custom VSA 225	ACME	225
113	Custom VSA 226	ACME	226
114	Custom VSA 227	ACME	227
115	Custom VSA 228	ACME	228
116	Custom VSA 229	ACME	229
117	Custom VSA 230	ACME	230
118	Calling-Media-Stop-Time	ACME	231
119	Called-Media-Stop-Time	ACME	232
120	Calling-Media-Stop-Time	ACME	233
121	Called-Media-Stop-Time	ACME	234
122	Flow Media Type	ACME	142
123	Flow Media Type	ACME	143
124	Flow Media Type	ACME	144
125	Flow Media Type	ACME	145
126	PGW-IP Address	ACME	249
127	SGW-IP Address	ACME	249
128	ORIG-IOI	ACME	249
129	TERM-IOI	ACME	249
130	IMEI	ACME	249
131	Node Functionality	ACME	249
132	History Info	ACME	250
133	P-Visited Network ID	ACME	251
134	IMSI	ACME	252
135	Access-Network-Information	ACME	248
136	CDR Sequence Number	ACME	59
137	Stir-Signed-Request	ACME	249
138	Stir-Signed-Request-Exception-Id	ACME	249
139	Stir-Verified-Request	ACME	249
140	Stir-Verified-Request-Exception-Id	ACME	249
141	Stir-VS-Verstat	ACME	249
142	Stir-VS-Reason	ACME	249
143	Stir-TN-Used-For-AS-VS-Request	ACME	249
144	Stir-Div-Signed-Request	ACME	249
145	Stir-Div-Verified-Request	ACME	249
146	History Info2	ACME	253

## Local CDR Interim Record (RADIUS)

The following table contains the local CDR layout, inclusive of all VSA data for an interim record, when RADIUS is selected as the account protocol.

**Table B-2 Local CDR Interim Record (RADIUS)**

CSV Position	Attribute Name	Vendor	CDR Number
1	Accounting Status	none	40
2	NAS IP Address	none	4
3	NAS Port	none	5
4	Accounting Session ID	none	44
5	Ingress Session ID	ACME	3
6	Egress Session ID	ACME	4
7	Session Protocol Type	ACME	43
8	Session-Forked-Call-Id	ACME	171
9	Generic ID	ACME	40
10	Calling Station ID	none	31
11	Called Station ID	none	30
12	Cisco Setup Time	CISCO	25
13	Cisco Connect Time	CISCO	28
14	Egress Network Interface ID	ACME	139
15	Egress Vlan Tag Value	ACME	140
16	Ingress Network Interface ID	ACME	137
17	Ingress Vlan Tag Value	ACME	138
18	Egress Realm	ACME	42
19	Ingress Realm	ACME	41
20	Flow Identifier	ACME	1
21	Flow Type	ACME	2
22	Flow Input Realm	ACME	10
23	Flow Input Src Addr	ACME	11
24	Flow Input Src Port	ACME	12
25	Flow Input Dest Address	ACME	13
26	Flow Input Dest Port	ACME	14
27	Flow Output Realm	ACME	20
28	Flow Output Src Address	ACME	21
29	Flow Output Src Port	ACME	22
30	Flow Output Dest Addr	ACME	23
31	Flow Output Dest Port	ACME	24
32	RTCP Calling Packets Lost	ACME	32
33	RTCP Calling Avg Jitter (msec)	ACME	33
34	RTCP Calling Avg Latency (msec)	ACME	34
35	RTCP Calling Max Jitter (msec)	ACME	35
36	RTCP Calling Max Latency (msec)	ACME	36
37	RTP Calling Packets Lost	ACME	37
38	RTP Calling Avg Jitter (msec)	ACME	38

**Table B-2 (Cont.) Local CDR Interim Record (RADIUS)**

<b>CSV Position</b>	<b>Attribute Name</b>	<b>Vendor</b>	<b>CDR Number</b>
39	RTP Calling Max Jitter (msec)	ACME	39
40	RTP Calling Octets	ACME	28
41	RTP Calling Packets	ACME	29
42	Calling R-Factor	ACME	151
43	Calling MOS	ACME	152
44	Flow Identifier	ACME	78
45	Flow Type	ACME	79
46	Flow Input Realm	ACME	80
47	Flow Input Src Addr	ACME	81
48	Flow Input Src Port	ACME	82
49	Flow Input Dest Address	ACME	83
50	Flow Input Dest Port	ACME	84
51	Flow Output Realm	ACME	85
52	Flow Output Src Address	ACME	86
53	Flow Output Src Port	ACME	87
54	Flow Output Dest Addr	ACME	88
55	Flow Output Dest Port	ACME	89
56	RTCP Called Packets Lost	ACME	46
57	RTCP Called Avg Jitter (msec)	ACME	47
58	RTCP Called Avg Latency (msec)	ACME	48
59	RTCP Called Max Jitter (msec)	ACME	49
60	RTCP Called Max Latency (msec)	ACME	50
61	RTP Called Packets Lost	ACME	51
62	RTP Called Avg Jitter (msec)	ACME	52
63	RTP Called Max Jitter (msec)	ACME	53
64	RTP Called Octets	ACME	44
65	RTP Called Packets	ACME	45
66	Called R-Factor	ACME	153
67	Called MOS	ACME	154
68	Flow Identifier	ACME	90
69	Flow Type	ACME	91
70	Flow Input Realm	ACME	92
71	Flow Input Src Addr	ACME	93
72	Flow Input Src Port	ACME	94
73	Flow Input Dest Address	ACME	95
74	Flow Input Dest Port	ACME	96
75	Flow Output Realm	ACME	97
76	Flow Output Src Address	ACME	98
77	Flow Output Src Port	ACME	99
78	Flow Output Dest Addr	ACME	100
79	Flow Output Dest Port	ACME	101
80	RTCP Calling Packets Lost	ACME	104
81	RTCP Calling Avg Jitter (msec)	ACME	105

**Table B-2 (Cont.) Local CDR Interim Record (RADIUS)**

<b>CSV Position</b>	<b>Attribute Name</b>	<b>Vendor</b>	<b>CDR Number</b>
82	RTCP Calling Avg Latency (msec)	ACME	106
83	RTCP Calling Max Jitter (msec)	ACME	107
84	RTCP Calling Max Latency (msec)	ACME	108
85	RTP Calling Packets Lost	ACME	109
86	RTP Calling Avg Jitter (msec)	ACME	110
87	RTP Calling Max Jitter (msec)	ACME	111
88	RTP Calling Octets	ACME	102
89	RTP Calling Packets	ACME	103
90	Flow Identifier	ACME	112
91	Flow Type	ACME	113
92	Flow Input Realm	ACME	114
93	Flow Input Src Addr	ACME	115
94	Flow Input Src Port	ACME	116
95	Flow Input Dest Address	ACME	117
96	Flow Input Dest Port	ACME	118
97	Flow Output Realm	ACME	119
98	Flow Output Src Address	ACME	120
99	Flow Output Src Port	ACME	121
100	Flow Output Dest Addr	ACME	122
101	Flow Output Dest Port	ACME	123
102	RTCP Called Packets Lost	ACME	126
103	RTCP Called Avg Jitter (msec)	ACME	127
104	RTCP Called Avg Latency (msec)	ACME	128
105	RTCP Called Max Jitter (msec)	ACME	129
106	RTCP Called Max Latency (msec)	ACME	130
107	RTP Called Packets Lost	ACME	131
108	RTP Called Avg Jitter (msec)	ACME	132
109	RTP Called Max Jitter (msec)	ACME	133
110	RTP Called Octets	ACME	124
111	RTP Called Packets	ACME	125
112	Charging Vector ICID	ACME	54
113	Charging Function Address	ACME	55
114	Firmware Version	ACME	56
115	Local timezone	ACME	57
116	Post Dial Delay (msec)	ACME	58
117	Primary routing Number	ACME	64
118	Originating Trunk Group	ACME	65
119	Terminating Trunk Group	ACME	66
120	Originating Trunk Context	ACME	67
121	Terminating Trunk Context	ACME	68
122	P Asserted ID	ACME	69
123	Ingress Local Address	ACME	74
124	Ingress Remote Address	ACME	75

**Table B-2 (Cont.) Local CDR Interim Record (RADIUS)**

<b>CSV Position</b>	<b>Attribute Name</b>	<b>Vendor</b>	<b>CDR Number</b>
125	Egress Local Address	ACME	76
126	Egress Remote Address	ACME	77
127	SIP DIVERSION	ACME	70
128	Intermediate Time	ACME	63
129	Accounting Session Time	NA	46
130	Egress Routing Number	ACME	134
131	Ingress RPH	ACME	135
132	Egress RPH	ACME	136
133	Custom VSA 200	ACME	200
134	Custom VSA 201	ACME	201
135	Custom VSA 202	ACME	202
136	Custom VSA 203	ACME	203
137	Custom VSA 204	ACME	204
138	Custom VSA 205	ACME	205
139	Custom VSA 206	ACME	206
140	Custom VSA 207	ACME	207
141	Custom VSA 208	ACME	208
142	Custom VSA 209	ACME	209
143	Custom VSA 210	ACME	210
144	Custom VSA 211	ACME	211
145	Custom VSA 212	ACME	212
146	Custom VSA 213	ACME	213
147	Custom VSA 214	ACME	214
148	Custom VSA 215	ACME	215
149	Custom VSA 216	ACME	216
150	Custom VSA 217	ACME	217
151	Custom VSA 218	ACME	218
152	Custom VSA 219	ACME	219
153	Custom VSA 220	ACME	220
154	Custom VSA 221	ACME	221
155	Custom VSA 222	ACME	222
156	Custom VSA 223	ACME	223
157	Custom VSA 224	ACME	224
158	Custom VSA 225	ACME	225
159	Custom VSA 226	ACME	226
160	Custom VSA 227	ACME	227
161	Custom VSA 228	ACME	228
162	Custom VSA 229	ACME	229
163	Custom VSA 230	ACME	230
164	Calling-Media-Stop-Time	ACME	231
165	Called-Media-Stop-Time	ACME	232
166	Calling-Media-Stop-Time	ACME	233
167	Called-Media-Stop-Time	ACME	234

**Table B-2 (Cont.) Local CDR Interim Record (RADIUS)**

CSV Position	Attribute Name	Vendor	CDR Number
168	Flow Media Type	ACME	142
169	Flow Media Type	ACME	143
170	Flow Media Type	ACME	144
171	Flow Media Type	ACME	145
172	PGW-IP Address	ACME	249
173	SGW-IP Address	ACME	249
174	ORIG-IOI	ACME	249
175	TERM-IOI	ACME	249
176	IMEI	ACME	249
177	Node Functionality	ACME	249
178	History Info	ACME	250
179	P-Visited Network ID	ACME	251
180	IMSI	ACME	252
181	Access-Network-Information	ACME	248
182	CDR Sequence Number	ACME	59
183	Stir-Signed-Request	ACME	249
184	Stir-Signed-Request-Exception-Id	ACME	249
185	Stir-Verified-Request	ACME	249
186	Stir-Verified-Request-Exception-Id	ACME	249
187	Stir-VS-Verstat	ACME	249
188	Stir-VS-Reason	ACME	249
189	Stir-TN-Used-For-AS-VS-Request	ACME	249
190	Stir-Div-Signed-Request	ACME	249
191	Stir-Div-Verified-Request	ACME	249
192	History Info2	ACME	253

## Local CDR Stop Record (RADIUS)

The following table contains the local CDR layout, inclusive of all VSA data for a Stop record, when RADIUS is selected as the account protocol.

**Table B-3 Local CDR Stop Record (RADIUS)**

CSV Position	Attribute Name	Vendor	CDR Number
1	Accounting Status	none	40
2	NAS IP Address	none	4
3	NAS Port	none	5
4	Accounting Session ID	none	44
5	Ingress Session ID	ACME	3
6	Egress Session ID	ACME	4
7	Session Protocol Type	ACME	43
8	Session-Forked-Call-Id	ACME	171



**Table B-3 (Cont.) Local CDR Stop Record (RADIUS)**

CSV Position	Attribute Name	Vendor	CDR Number
9	Generic ID	ACME	40
10	Calling Station ID	none	31
11	Called Station ID	none	30
12	Accounting Termination Cause	none	49
13	Accounting Session Time	none	46
14	Cisco Setup Time	CISCO	25
15	Cisco Connect Time	CISCO	28
16	Cisco Disconnect Time	CISCO	29
17	Cisco Disconnect Cause	CISCO	30
18	Egress Network Interface ID	ACME	139
19	Egress Vlan Tag Value	ACME	140
20	Ingress Network Interface ID	ACME	137
21	Ingress Vlan Tag Value	ACME	138
22	Egress Realm	ACME	42
23	Ingress Realm	ACME	41
24	Flow Identifier	ACME	1
25	Flow Type	ACME	2
26	Flow Input Realm	ACME	10
27	Flow Input Src Addr	ACME	11
28	Flow Input Src Port	ACME	12
29	Flow Input Dest Address	ACME	13
30	Flow Input Dest Port	ACME	14
31	Flow Output Realm	ACME	20
32	Flow Output Src Address	ACME	21
33	Flow Output Src Port	ACME	22
34	Flow Output Dest Addr	ACME	23
35	Flow Output Dest Port	ACME	24
36	RTCP Calling Packets Lost	ACME	32
37	RTCP Calling Avg Jitter (msec)	ACME	33
38	RTCP Calling Avg Latency (msec)	ACME	34
39	RTCP Calling Max Jitter (msec)	ACME	35
40	RTCP Calling Max Latency (msec)	ACME	36
41	RTP Calling Packets Lost	ACME	37
42	RTP Calling Avg Jitter (msec)	ACME	38
43	RTP Calling Max Jitter (msec)	ACME	39
44	RTP Calling Octets	ACME	28
45	RTP Calling Packets	ACME	29
46	Calling R-Factor	ACME	151
47	Calling MOS	ACME	152
48	Flow Identifier	ACME	78
49	Flow Type	ACME	79
50	Flow Input Realm	ACME	80
51	Flow Input Src Addr	ACME	81

Table B-3 (Cont.) Local CDR Stop Record (RADIUS)

CSV Position	Attribute Name	Vendor	CDR Number
52	Flow Input Src Port	ACME	82
53	Flow Input Dest Address	ACME	83
54	Flow Input Dest Port	ACME	84
55	Flow Output Realm	ACME	85
56	Flow Output Src Address	ACME	86
57	Flow Output Src Port	ACME	87
58	Flow Output Dest Addr	ACME	88
59	Flow Output Dest Port	ACME	89
60	RTCP Called Packets Lost	ACME	46
61	RTCP Called Avg Jitter (msec)	ACME	47
62	RTCP Called Avg Latency (msec)	ACME	48
63	RTCP Called Max Jitter (msec)	ACME	49
64	RTCP Called Max Latency (msec)	ACME	50
65	RTP Called Packets Lost	ACME	51
66	RTP Called Avg Jitter (msec)	ACME	52
67	RTP Called Max Jitter (msec)	ACME	53
68	RTP Called Octets	ACME	44
69	RTP Called Packets	ACME	45
70	Called R-Factor	ACME	153
71	Called MOS	ACME	154
72	Flow Identifier	ACME	90
73	Flow Type	ACME	91
74	Flow Input Realm	ACME	92
75	Flow Input Src Addr	ACME	93
76	Flow Input Src Port	ACME	94
77	Flow Input Dest Address	ACME	95
78	Flow Input Dest Port	ACME	96
79	Flow Output Realm	ACME	97
80	Flow Output Src Address	ACME	98
81	Flow Output Src Port	ACME	99
82	Flow Output Dest Addr	ACME	100
83	Flow Output Dest Port	ACME	101
84	RTCP Calling Packets Lost	ACME	104
85	RTCP Calling Avg Jitter (msec)	ACME	105
86	RTCP Calling Avg Latency (msec)	ACME	106
87	RTCP Calling Max Jitter (msec)	ACME	107
88	RTCP Calling Max Latency (msec)	ACME	108
89	RTP Calling Packets Lost	ACME	109
90	RTP Calling Avg Jitter (msec)	ACME	110
91	RTP Calling Max Jitter (msec)	ACME	111
92	RTP Calling Octets	ACME	102
93	RTP Calling Packets	ACME	103
94	Flow Identifier	ACME	112

**Table B-3 (Cont.) Local CDR Stop Record (RADIUS)**

CSV Position	Attribute Name	Vendor	CDR Number
95	Flow Type	ACME	113
96	Flow Input Realm	ACME	114
97	Flow Input Src Addr	ACME	115
98	Flow Input Src Port	ACME	116
99	Flow Input Dest Address	ACME	117
100	Flow Input Dest Port	ACME	118
101	Flow Output Realm	ACME	119
102	Flow Output Src Address	ACME	120
103	Flow Output Src Port	ACME	121
104	Flow Output Dest Addr	ACME	122
105	Flow Output Dest Port	ACME	123
106	RTCP Called Packets Lost	ACME	126
107	RTCP Called Avg Jitter (msec)	ACME	127
108	RTCP Called Avg Latency (msec)	ACME	128
109	RTCP Called Max Jitter (msec)	ACME	129
110	RTCP Called Max Latency (msec)	ACME	130
111	RTP Called Packets Lost	ACME	131
112	RTP Called Avg Jitter (msec)	ACME	132
113	RTP Called Max Jitter (msec)	ACME	133
114	RTP Called Octets	ACME	124
115	RTP Called Packets	ACME	125
116	Charging Vector ICID	ACME	54
117	Charging Function Address	ACME	55
118	Firmware Version	ACME	56
119	Local timezone	ACME	57
120	Post Dial Delay (msec)	ACME	58
121	Primary routing Number	ACME	64
122	Originating Trunk Group	ACME	65
123	Terminating Trunk Group	ACME	66
124	Originating Trunk Context	ACME	67
125	Terminating Trunk Context	ACME	68
126	P Asserted ID	ACME	69
127	Ingress Local Address	ACME	74
128	Ingress Remote Address	ACME	75
129	Egress Local Address	ACME	76
130	Egress Remote Address	ACME	77
131	SIP DIVERSION	ACME	70
132	Session Disposition	ACME	60
133	Disconnect Initiator	ACME	61
134	Disconnect Cause	ACME	62
135	Sip Status Code	ACME	71
136	Egress Routing Number	ACME	134
137	Ingress RPH	ACME	135

Table B-3 (Cont.) Local CDR Stop Record (RADIUS)

CSV Position	Attribute Name	Vendor	CDR Number
138	Egress RPH	ACME	136
139	refer call transfer ID	ACME	141
140	Custom VSA 200	ACME	200
141	Custom VSA 201	ACME	201
142	Custom VSA 202	ACME	202
143	Custom VSA 203	ACME	203
144	Custom VSA 204	ACME	204
145	Custom VSA 205	ACME	205
146	Custom VSA 206	ACME	206
147	Custom VSA 207	ACME	207
148	Custom VSA 208	ACME	208
149	Custom VSA 209	ACME	209
150	Custom VSA 210	ACME	210
151	Custom VSA 211	ACME	211
152	Custom VSA 212	ACME	212
153	Custom VSA 213	ACME	213
154	Custom VSA 214	ACME	214
155	Custom VSA 215	ACME	215
156	Custom VSA 216	ACME	216
157	Custom VSA 217	ACME	217
158	Custom VSA 218	ACME	218
159	Custom VSA 219	ACME	219
160	Custom VSA 220	ACME	220
161	Custom VSA 221	ACME	221
162	Custom VSA 222	ACME	222
163	Custom VSA 223	ACME	223
164	Custom VSA 224	ACME	224
165	Custom VSA 225	ACME	225
166	Custom VSA 226	ACME	226
167	Custom VSA 227	ACME	227
168	Custom VSA 228	ACME	228
169	Custom VSA 229	ACME	229
170	Custom VSA 230	ACME	230
171	Calling-Media-Stop-Time	ACME	231
172	Called-Media-Stop-Time	ACME	232
173	Calling-Media-Stop-Time	ACME	233
174	Called-Media-Stop-Time	ACME	234
175	Flow Media Type	ACME	142
176	Flow Media Type	ACME	143
177	Flow Media Type	ACME	144
178	Flow Media Type	ACME	145
179	RTP Calling Octets Transmitted	ACME	240
180	RTP Calling Packets Transmitted	ACME	241

**Table B-3 (Cont.) Local CDR Stop Record (RADIUS)**

CSV Position	Attribute Name	Vendor	CDR Number
181	RTP Called Octets Transmitted	ACME	242
182	RTP Called Packets Transmitted	ACME	243
183	RTP Calling Octets Transmitted	ACME	244
184	RTP Calling Packets Transmitted	ACME	245
185	RTP Calling Octets Transmitted	ACME	244
186	RTP Calling Packets Transmitted	ACME	245
187	MSRP Called Octets	ACME	249
188	MSRP Called Packets	ACME	249
189	MSRP Called Octets Transmitted	ACME	249
190	MSRP Called Packets Transmitted	ACME	249
191	MSRP Calling Octets	ACME	249
192	MSRP Calling Packets	ACME	249
193	MSRP Calling Octets Transmitted	ACME	249
194	MSRP Calling Packets Transmitted	ACME	249
195	PGW-IP Address	ACME	249
196	SGW-IP Address	ACME	249
197	ORIG-IOI	ACME	249
198	TERM-IOI	ACME	249
199	IMEI	ACME	249
200	Node Functionality	ACME	249
201	History Info	ACME	250
202	P-Visited Network ID	ACME	251
203	IMSI	ACME	252
204	Access-Network-Information	ACME	248
205	CDR Sequence Number	ACME	59
206	Stir-Signed-Request	ACME	249
207	Stir-Signed-Request-Exception-Id	ACME	249
208	Stir-Verified-Request	ACME	249
209	Stir-Verified-Request-Exception-Id	ACME	249
210	Stir-VS-Verstat	ACME	249
211	Stir-VS-Reason	ACME	249
212	Stir-TN-Used-For-AS-VS-Request	ACME	249
213	Stir-Div-Signed-Request	ACME	249
214	Stir-Div-Verified-Request	ACME	249
215	History Info2	ACME	253

## Local CDR Message Record for SMS (RADIUS)

The SBC creates an Message CSV file for SMS messages when the generate-event = message parameter is enabled. The following table shows the inclusive CSV element order, when protocol = RADIUS (or protocol=default).

**Table B-4 Local CDR Message Record (RADIUS)**

CSV Position	Attribute Name	Vendor ID	CDR Number
1	"Accounting Status"	none	40
2	"NAS IP Address"	none	4
3	"NAS Port"	none	5
4	"Accounting Session ID"	none	44
5	"Ingress Session ID"	ACME	3
6	"Egress Session ID"	ACME	4
7	"Session Protocol Type"	ACME	43
8	"Session-Forked-Call-Id"	ACME	171
9	"Generic ID"	ACME	40
10	"Calling Station ID"	none	31
11	"Called Station ID"	none	30
12	"Egress Network Interface ID "	ACME	139
13	"Egress Vlan Tag Value "	ACME	140
14	"Ingress Network Interface ID "	ACME	137
15	"Ingress Vlan Tag Value "	ACME	138
16	"Cisco Setup Time"	CISCO	25
17	"Cisco Connect Time"	CISCO	28
18	"Custom VSA 200"	ACME	200
19	"Custom VSA 201"	ACME	201
20	"Custom VSA 202"	ACME	202
21	"Custom VSA 203"	ACME	203
22	"Custom VSA 204"	ACME	204
23	"Custom VSA 205"	ACME	205
24	"Custom VSA 206"	ACME	206
25	"Custom VSA 207"	ACME	207
26	"Custom VSA 208"	ACME	208
27	"Custom VSA 209"	ACME	209
28	"Custom VSA 210"	ACME	210
29	"Custom VSA 211"	ACME	211
30	"Custom VSA 212"	ACME	212
31	"Custom VSA 213"	ACME	213
32	"Custom VSA 214"	ACME	214
33	"Custom VSA 215"	ACME	215
34	"Custom VSA 216"	ACME	216
35	"Custom VSA 217"	ACME	217
36	"Custom VSA 218"	ACME	218
37	"Custom VSA 219"	ACME	219
38	"Custom VSA 220"	ACME	220
39	"Custom VSA 221"	ACME	221
40	"Custom VSA 222"	ACME	222
41	"Custom VSA 223"	ACME	223
42	"Custom VSA 224"	ACME	224
43	"Custom VSA 225"	ACME	225

**Table B-4 (Cont.) Local CDR Message Record (RADIUS)**

CSV Position	Attribute Name	Vendor ID	CDR Number
44	"Custom VSA 226"	ACME	226
45	"Custom VSA 227"	ACME	227
46	"Custom VSA 228"	ACME	228
47	"Custom VSA 229"	ACME	229
48	"Custom VSA 230"	ACME	230
49	"PGW-IP Address"	ACME	249
50	"SGW-IP Address"	ACME	249
51	"ORIG-IOI"	ACME	249
52	"TERM-IOI"	ACME	249
53	"IMEI"	ACME	249
54	"Node Functionality"	ACME	249
55	"Sms-Msg-Type"	ACME	249
56	"Sms-Calling-Party-Number"	ACME	249
57	"Sms-Called-Party-Number"	ACME	249
58	"Sms-Msg-length"	ACME	249
59	"P-Visited Network ID"	ACME	251
60	"IMSI"	ACME	252
61	"Access-Network-Information"	ACME	248
62	"CDR Sequence Number "	ACME	59

## Local CDR Start Record (Diameter)

The following table contains the local CDR layout, inclusive of all VSA data for a start record, when Diameter is selected as the account protocol.

**Table B-5 Local CDR Start Record (Diameter)**

CSV Position	Attribute Name	Vendor	CDR Number
1	Accounting Status	none	40
2	NAS IP Address	none	4
3	NAS Port	none	5
4	Accounting Session ID	none	44
5	Ingress Session ID	ACME	3
6	Egress Session ID	ACME	4
7	Session Protocol Type	ACME	43
8	Session-Forked-Call-Id	ACME	171
9	Generic ID	ACME	40
10	Calling Station ID	none	31
11	Called Station ID	none	30
12	Cisco Setup Time	CISCO	25
13	Cisco Connect Time	CISCO	28
14	Egress Network Interface ID	ACME	139

Table B-5 (Cont.) Local CDR Start Record (Diameter)

CSV Position	Attribute Name	Vendor	CDR Number
15	Egress Vlan Tag Value	ACME	140
16	Ingress Network Interface ID	ACME	137
17	Ingress Vlan Tag Value	ACME	138
18	Egress Realm	ACME	42
19	Ingress Realm	ACME	41
20	Flow Identifier	ACME	1
21	Flow Type	ACME	2
22	Flow Input Realm	ACME	10
23	Flow Input Src Addr	ACME	11
24	Flow Input Src Port	ACME	12
25	Flow Input Dest Address	ACME	13
26	Flow Input Dest Port	ACME	14
27	Flow Output Realm	ACME	20
28	Flow Output Src Address	ACME	21
29	Flow Output Src Port	ACME	22
30	Flow Output Dest Addr	ACME	23
31	Flow Output Dest Port	ACME	24
32	Flow Identifier	ACME	78
33	Flow Type	ACME	79
34	Flow Input Realm	ACME	80
35	Flow Input Src Addr	ACME	81
36	Flow Input Src Port	ACME	82
37	Flow Input Dest Address	ACME	83
38	Flow Input Dest Port	ACME	84
39	Flow Output Realm	ACME	85
40	Flow Output Src Address	ACME	86
41	Flow Output Src Port	ACME	87
42	Flow Output Dest Addr	ACME	88
43	Flow Output Dest Port	ACME	89
44	Flow Identifier	ACME	90
45	Flow Type	ACME	91
46	Flow Input Realm	ACME	92
47	Flow Input Src Addr	ACME	93
48	Flow Input Src Port	ACME	94
49	Flow Input Dest Address	ACME	95
50	Flow Input Dest Port	ACME	96
51	Flow Output Realm	ACME	97
52	Flow Output Src Address	ACME	98
53	Flow Output Src Port	ACME	99
54	Flow Output Dest Addr	ACME	100
55	Flow Output Dest Port	ACME	101
56	Flow Identifier	ACME	112
57	Flow Type	ACME	113



**Table B-5 (Cont.) Local CDR Start Record (Diameter)**

CSV Position	Attribute Name	Vendor	CDR Number
58	Flow Input Realm	ACME	114
59	Flow Input Src Addr	ACME	115
60	Flow Input Src Port	ACME	116
61	Flow Input Dest Address	ACME	117
62	Flow Input Dest Port	ACME	118
63	Flow Output Realm	ACME	119
64	Flow Output Src Address	ACME	120
65	Flow Output Src Port	ACME	121
66	Flow Output Dest Addr	ACME	122
67	Flow Output Dest Port	ACME	123
68	Charging Vector ICID	ACME	54
69	Charging Function Address	ACME	55
70	Firmware Version	ACME	56
71	Local timezone	ACME	57
72	Post Dial Delay (msec)	ACME	58
73	Primary routing Number	ACME	64
74	Originating Trunk Group	ACME	65
75	Terminating Trunk Group	ACME	66
76	Originating Trunk Context	ACME	67
77	Terminating Trunk Context	ACME	68
78	P Asserted ID	ACME	69
79	Ingress Local Address	ACME	74
80	Ingress Remote Address	ACME	75
81	Egress Local Address	ACME	76
82	Egress Remote Address	ACME	77
83	SIP DIVERSION	ACME	70
84	Egress Routing Number	ACME	134
85	Ingress RPH	ACME	135
86	Egress RPH	ACME	136
87	Diam-Session-Id	ACME	172
88	Sip-Method	ACME	173
89	Event-Time	ACME	176
90	Content-Disposition	ACME	4119
91	Originator	ACME	4120
92	Subscription-ID-Data	ACME	4110
93	Subscription-ID-Type	ACME	4111
94	Service-Context-ID	ACME	4121
95	Called-Asserted-Identity	ACME	4117
96	SDP-Media	ACME	177
97	SDP-Type	ACME	4114
98	SDP-Offer-Timestamp	ACME	4115
99	SDP-Answer-Timestamp	ACME	4116
100	Early-SDP-Media	ACME	4123

**Table B-5 (Cont.) Local CDR Start Record (Diameter)**

<b>CSV Position</b>	<b>Attribute Name</b>	<b>Vendor</b>	<b>CDR Number</b>
101	Early-SDP-Type	ACME	4122
102	Served-Party-IP	ACME	4098
103	User-Name	ACME	4097
104	Node-Func	ACME	4100
105	ApplicationId	ACME	4101
106	Role-Of-Node	ACME	4102
107	SIP-Request-Timestamp	ACME	4124
108	SIP-Request-Timestamp-Fraction	ACME	4112
109	SIP-Response-Timestamp	ACME	4125
110	SIP-Response-Timestamp-Fraction	ACME	4113
111	Access-Network-Information	ACME	248
112	Custom VSA 200	ACME	200
113	Custom VSA 201	ACME	201
114	Custom VSA 202	ACME	202
115	Custom VSA 203	ACME	203
116	Custom VSA 204	ACME	204
117	Custom VSA 205	ACME	205
118	Custom VSA 206	ACME	206
119	Custom VSA 207	ACME	207
120	Custom VSA 208	ACME	208
121	Custom VSA 209	ACME	209
122	Custom VSA 210	ACME	210
123	Custom VSA 211	ACME	211
124	Custom VSA 212	ACME	212
125	Custom VSA 213	ACME	213
126	Custom VSA 214	ACME	214
127	Custom VSA 215	ACME	215
128	Custom VSA 216	ACME	216
129	Custom VSA 217	ACME	217
130	Custom VSA 218	ACME	218
131	Custom VSA 219	ACME	219
132	Custom VSA 220	ACME	220
133	Custom VSA 221	ACME	221
134	Custom VSA 222	ACME	222
135	Custom VSA 223	ACME	223
136	Custom VSA 224	ACME	224
137	Custom VSA 225	ACME	225
138	Custom VSA 226	ACME	226
139	Custom VSA 227	ACME	227
140	Custom VSA 228	ACME	228
141	Custom VSA 229	ACME	229

**Table B-5 (Cont.) Local CDR Start Record (Diameter)**

CSV Position	Attribute Name	Vendor	CDR Number
142	Custom VSA 230	ACME	230
143	Calling-Media-Stop-Time	ACME	231
144	Called-Media-Stop-Time	ACME	232
145	Calling-Media-Stop-Time	ACME	233
146	Called-Media-Stop-Time	ACME	234
147	Flow Media Type	ACME	142
148	Flow Media Type	ACME	143
149	Flow Media Type	ACME	144
150	Flow Media Type	ACME	145
151	PGW-IP Address	ACME	249
152	SGW-IP Address	ACME	249
153	ORIG-IOI	ACME	249
154	TERM-IOI	ACME	249
155	IMEI	ACME	249
156	Node Functionality	ACME	249
157	History Info	ACME	250
158	P-Visited Network ID	ACME	251
159	IMSI	ACME	252
160	CDR Sequence Number	ACME	59
161	Origin-Realm	ACME	4103
162	Origin-Host	ACME	4104
163	Destination-Realm	ACME	4105
164	Destination-Host	ACME	4106
165	Stir-Signed-Request	ACME	249
166	Stir-Signed-Request-Exception-Id	ACME	249
167	Stir-Verified-Request	ACME	249
168	Stir-Verified-Request-Exception-Id	ACME	249
169	Stir-VS-Verstat	ACME	249
170	Stir-VS-Reason	ACME	249
171	Stir-TN-Used-For-AS-VS-Request	ACME	249
172	Stir-Div-Signed-Request	ACME	249
173	Stir-Div-Verified-Request	ACME	249
174	History Info2	ACME	253

## Local CDR Interim Record (Diameter)

The following table contains the local CDR layout, inclusive of all VSA data for a start record, when Diameter is selected as the account protocol.

**Table B-6 Local CDR Interim Record (Diameter)**

CSV Position	Attribute Name	Vendor	CDR Number
1	Accounting Status	none	40
2	NAS IP Address	none	4
3	NAS Port	none	5
4	Accounting Session ID	none	44
5	Ingress Session ID	ACME	3
6	Egress Session ID	ACME	4
7	Session Protocol Type	ACME	43
8	Session-Forked-Call-Id	ACME	171
9	Generic ID	ACME	40
10	Calling Station ID	none	31
11	Called Station ID	none	30
12	Cisco Setup Time	CISCO	25
13	Cisco Connect Time	CISCO	28
14	Egress Network Interface ID	ACME	139
15	Egress Vlan Tag Value	ACME	140
16	Ingress Network Interface ID	ACME	137
17	Ingress Vlan Tag Value	ACME	138
18	Egress Realm	ACME	42
19	Ingress Realm	ACME	41
20	Flow Identifier	ACME	1
21	Flow Type	ACME	2
22	Flow Input Realm	ACME	10
23	Flow Input Src Addr	ACME	11
24	Flow Input Src Port	ACME	12
25	Flow Input Dest Address	ACME	13
26	Flow Input Dest Port	ACME	14
27	Flow Output Realm	ACME	20
28	Flow Output Src Address	ACME	21
29	Flow Output Src Port	ACME	22
30	Flow Output Dest Addr	ACME	23
31	Flow Output Dest Port	ACME	24
32	RTCP Calling Packets Lost	ACME	32
33	RTCP Calling Avg Jitter (msec)	ACME	33
34	RTCP Calling Avg Latency (msec)	ACME	34
35	RTCP Calling Max Jitter (msec)	ACME	35
36	RTCP Calling Max Latency (msec)	ACME	36
37	RTP Calling Packets Lost	ACME	37
38	RTP Calling Avg Jitter (msec)	ACME	38
39	RTP Calling Max Jitter (msec)	ACME	39
40	RTP Calling Octets	ACME	28
41	RTP Calling Packets	ACME	29
42	Calling R-Factor	ACME	151
43	Calling MOS	ACME	152

**Table B-6 (Cont.) Local CDR Interim Record (Diameter)**

<b>CSV Position</b>	<b>Attribute Name</b>	<b>Vendor</b>	<b>CDR Number</b>
44	Flow Identifier	ACME	78
45	Flow Type	ACME	79
46	Flow Input Realm	ACME	80
47	Flow Input Src Addr	ACME	81
48	Flow Input Src Port	ACME	82
49	Flow Input Dest Address	ACME	83
50	Flow Input Dest Port	ACME	84
51	Flow Output Realm	ACME	85
52	Flow Output Src Address	ACME	86
53	Flow Output Src Port	ACME	87
54	Flow Output Dest Addr	ACME	88
55	Flow Output Dest Port	ACME	89
56	RTCP Called Packets Lost	ACME	46
57	RTCP Called Avg Jitter (msec)	ACME	47
58	RTCP Called Avg Latency (msec)	ACME	48
59	RTCP Called Max Jitter (msec)	ACME	49
60	RTCP Called Max Latency (msec)	ACME	50
61	RTP Called Packets Lost	ACME	51
62	RTP Called Avg Jitter (msec)	ACME	52
63	RTP Called Max Jitter (msec)	ACME	53
64	RTP Called Octets	ACME	44
65	RTP Called Packets	ACME	45
66	Called R-Factor	ACME	153
67	Called MOS	ACME	154
68	Flow Identifier	ACME	90
69	Flow Type	ACME	91
70	Flow Input Realm	ACME	92
71	Flow Input Src Addr	ACME	93
72	Flow Input Src Port	ACME	94
73	Flow Input Dest Address	ACME	95
74	Flow Input Dest Port	ACME	96
75	Flow Output Realm	ACME	97
76	Flow Output Src Address	ACME	98
77	Flow Output Src Port	ACME	99
78	Flow Output Dest Addr	ACME	100
79	Flow Output Dest Port	ACME	101
80	RTCP Calling Packets Lost	ACME	104
81	RTCP Calling Avg Jitter (msec)	ACME	105
82	RTCP Calling Avg Latency (msec)	ACME	106
83	RTCP Calling Max Jitter (msec)	ACME	107
84	RTCP Calling Max Latency (msec)	ACME	108
85	RTP Calling Packets Lost	ACME	109
86	RTP Calling Avg Jitter (msec)	ACME	110

Table B-6 (Cont.) Local CDR Interim Record (Diameter)

CSV Position	Attribute Name	Vendor	CDR Number
87	RTP Calling Max Jitter (msec)	ACME	111
88	RTP Calling Octets	ACME	102
89	RTP Calling Packets	ACME	103
90	Flow Identifier	ACME	112
91	Flow Type	ACME	113
92	Flow Input Realm	ACME	114
93	Flow Input Src Addr	ACME	115
94	Flow Input Src Port	ACME	116
95	Flow Input Dest Address	ACME	117
96	Flow Input Dest Port	ACME	118
97	Flow Output Realm	ACME	119
98	Flow Output Src Address	ACME	120
99	Flow Output Src Port	ACME	121
100	Flow Output Dest Addr	ACME	122
101	Flow Output Dest Port	ACME	123
102	RTCP Called Packets Lost	ACME	126
103	RTCP Called Avg Jitter (msec)	ACME	127
104	RTCP Called Avg Latency (msec)	ACME	128
105	RTCP Called Max Jitter (msec)	ACME	129
106	RTCP Called Max Latency (msec)	ACME	130
107	RTP Called Packets Lost	ACME	131
108	RTP Called Avg Jitter (msec)	ACME	132
109	RTP Called Max Jitter (msec)	ACME	133
110	RTP Called Octets	ACME	124
111	RTP Called Packets	ACME	125
112	Charging Vector ICID	ACME	54
113	Charging Function Address	ACME	55
114	Firmware Version	ACME	56
115	Local timezone	ACME	57
116	Post Dial Delay (msec)	ACME	58
117	Primary routing Number	ACME	64
118	Originating Trunk Group	ACME	65
119	Terminating Trunk Group	ACME	66
120	Originating Trunk Context	ACME	67
121	Terminating Trunk Context	ACME	68
122	P Asserted ID	ACME	69
123	Ingress Local Address	ACME	74
124	Ingress Remote Address	ACME	75
125	Egress Local Address	ACME	76
126	Egress Remote Address	ACME	77
127	SIP DIVERSION	ACME	70
128	Intermediate Time	ACME	63
129	Accounting Session Time	none	46

**Table B-6 (Cont.) Local CDR Interim Record (Diameter)**

CSV Position	Attribute Name	Vendor	CDR Number
130	Egress Routing Number	ACME	134
131	Ingress RPH	ACME	135
132	Egress RPH	ACME	136
133	Diam-Session-Id	ACME	172
134	Sip-Method	ACME	173
135	Event-Time	ACME	176
136	Content-Disposition	ACME	4119
137	Originator	ACME	4120
138	Subscription-ID-Data	ACME	4110
139	Subscription-ID-Type	ACME	4111
140	Service-Context-ID	ACME	4121
141	Called-Asserted-Identity	ACME	4117
142	SDP-Media	ACME	177
143	SDP-Type	ACME	4114
144	Served-Party-IP	ACME	4098
145	User-Name	ACME	4097
146	Node-Func	ACME	4100
147	ApplicationId	ACME	4101
148	Role-Of-Node	ACME	4102
149	SIP-Request-Timestamp	ACME	4124
150	SIP-Request-Timestamp-Fraction	ACME	4112
151	SIP-Response-Timestamp	ACME	4125
152	SIP-Response-Timestamp-Fraction	ACME	4113
153	Access-Network-Information	ACME	248
154	Custom VSA 200	ACME	200
155	Custom VSA 201	ACME	201
156	Custom VSA 202	ACME	202
157	Custom VSA 203	ACME	203
158	Custom VSA 204	ACME	204
159	Custom VSA 205	ACME	205
160	Custom VSA 206	ACME	206
161	Custom VSA 207	ACME	207
162	Custom VSA 208	ACME	208
163	Custom VSA 209	ACME	209
164	Custom VSA 210	ACME	210
165	Custom VSA 211	ACME	211
166	Custom VSA 212	ACME	212
167	Custom VSA 213	ACME	213
168	Custom VSA 214	ACME	214
169	Custom VSA 215	ACME	215
170	Custom VSA 216	ACME	216
171	Custom VSA 217	ACME	217

Table B-6 (Cont.) Local CDR Interim Record (Diameter)

CSV Position	Attribute Name	Vendor	CDR Number
172	Custom VSA 218	ACME	218
173	Custom VSA 219	ACME	219
174	Custom VSA 220	ACME	220
175	Custom VSA 221	ACME	221
176	Custom VSA 222	ACME	222
177	Custom VSA 223	ACME	223
178	Custom VSA 224	ACME	224
179	Custom VSA 225	ACME	225
180	Custom VSA 226	ACME	226
181	Custom VSA 227	ACME	227
182	Custom VSA 228	ACME	228
183	Custom VSA 229	ACME	229
184	Custom VSA 230	ACME	230
185	Calling-Media-Stop-Time	ACME	231
186	Called-Media-Stop-Time	ACME	232
187	Calling-Media-Stop-Time	ACME	233
188	Called-Media-Stop-Time	ACME	234
189	Flow Media Type	ACME	142
190	Flow Media Type	ACME	143
191	Flow Media Type	ACME	144
192	Flow Media Type	ACME	145
193	PGW-IP Address	ACME	249
194	SGW-IP Address	ACME	249
195	ORIG-IOI	ACME	249
196	TERM-IOI	ACME	249
197	IMEI	ACME	249
198	Node Functionality	ACME	249
199	History Info	ACME	250
200	P-Visited Network ID	ACME	251
201	IMSI	ACME	252
202	Reason-Header	none	3401
203	CDR Sequence Number	ACME	59
204	Origin-Realm	ACME	4103
205	Origin-Host	ACME	4104
206	Destination-Realm	ACME	4105
207	Destination-Host	ACME	4106
208	Stir-Signed-Request	ACME	249
209	Stir-Signed-Request-Exception-Id	ACME	249
210	Stir-Verified-Request	ACME	249
211	Stir-Verified-Request-Exception-Id	ACME	249
212	Stir-VS-Verstat	ACME	249
213	Stir-VS-Reason	ACME	249
214	Stir-TN-Used-For-AS-VS-Request	ACME	249



**Table B-6 (Cont.) Local CDR Interim Record (Diameter)**

CSV Position	Attribute Name	Vendor	CDR Number
215	Stir-Div-Signed-Request	ACME	249
216	Stir-Div-Verified-Request	ACME	249
217	History Info2	ACME	253

## Local CDR Stop Record (Diameter)

The following table contains the local CDR layout, inclusive of all VSA data for a start record, when Diameter is selected as the account protocol.

**Table B-7 Local CDR Stop Record (Diameter)**

CSV Position	Attribute Name	Vendor	CDR Number
1	Accounting Status	none	40
2	NAS IP Address	none	4
3	NAS Port	none	5
4	Accounting Session ID	none	44
5	Ingress Session ID	ACME	3
6	Egress Session ID	ACME	4
7	Session Protocol Type	ACME	43
8	Session-Forked-Call-Id	ACME	171
9	Generic ID	ACME	40
10	Calling Station ID	none	31
11	Called Station ID	none	30
12	Accounting Termination Cause	none	49
13	Accounting Session Time	none	46
14	Cisco Setup Time	CISCO	25
15	Cisco Connect Time	CISCO	28
16	Cisco Disconnect Time	CISCO	29
17	Cisco Disconnect Cause	CISCO	30
18	Egress Network Interface ID	ACME	139
19	Egress Vlan Tag Value	ACME	140
20	Ingress Network Interface ID	ACME	137
21	Ingress Vlan Tag Value	ACME	138
22	Egress Realm	ACME	42
23	Ingress Realm	ACME	41
24	Flow Identifier	ACME	1
25	Flow Type	ACME	2
26	Flow Input Realm	ACME	10
27	Flow Input Src Addr	ACME	11
28	Flow Input Src Port	ACME	12
29	Flow Input Dest Address	ACME	13
30	Flow Input Dest Port	ACME	14

**Table B-7 (Cont.) Local CDR Stop Record (Diameter)**

<b>CSV Position</b>	<b>Attribute Name</b>	<b>Vendor</b>	<b>CDR Number</b>
31	Flow Output Realm	ACME	20
32	Flow Output Src Address	ACME	21
33	Flow Output Src Port	ACME	22
34	Flow Output Dest Addr	ACME	23
35	Flow Output Dest Port	ACME	24
36	RTCP Calling Packets Lost	ACME	32
37	RTCP Calling Avg Jitter (msec)	ACME	33
38	RTCP Calling Avg Latency (msec)	ACME	34
39	RTCP Calling Max Jitter (msec)	ACME	35
40	RTCP Calling Max Latency (msec)	ACME	36
41	RTP Calling Packets Lost	ACME	37
42	RTP Calling Avg Jitter (msec)	ACME	38
43	RTP Calling Max Jitter (msec)	ACME	39
44	RTP Calling Octets	ACME	28
45	RTP Calling Packets	ACME	29
46	Calling R-Factor	ACME	151
47	Calling MOS	ACME	152
48	Flow Identifier	ACME	78
49	Flow Type	ACME	79
50	Flow Input Realm	ACME	80
51	Flow Input Src Addr	ACME	81
52	Flow Input Src Port	ACME	82
53	Flow Input Dest Address	ACME	83
54	Flow Input Dest Port	ACME	84
55	Flow Output Realm	ACME	85
56	Flow Output Src Address	ACME	86
57	Flow Output Src Port	ACME	87
58	Flow Output Dest Addr	ACME	88
59	Flow Output Dest Port	ACME	89
60	RTCP Called Packets Lost	ACME	46
61	RTCP Called Avg Jitter (msec)	ACME	47
62	RTCP Called Avg Latency (msec)	ACME	48
63	RTCP Called Max Jitter (msec)	ACME	49
64	RTCP Called Max Latency (msec)	ACME	50
65	RTP Called Packets Lost	ACME	51
66	RTP Called Avg Jitter (msec)	ACME	52
67	RTP Called Max Jitter (msec)	ACME	53
68	RTP Called Octets	ACME	44
69	RTP Called Packets	ACME	45
70	Called R-Factor	ACME	153

**Table B-7 (Cont.) Local CDR Stop Record (Diameter)**

<b>CSV Position</b>	<b>Attribute Name</b>	<b>Vendor</b>	<b>CDR Number</b>
71	Called MOS	ACME	154
72	Flow Identifier	ACME	90
73	Flow Type	ACME	91
74	Flow Input Realm	ACME	92
75	Flow Input Src Addr	ACME	93
76	Flow Input Src Port	ACME	94
77	Flow Input Dest Address	ACME	95
78	Flow Input Dest Port	ACME	96
79	Flow Output Realm	ACME	97
80	Flow Output Src Address	ACME	98
81	Flow Output Src Port	ACME	99
82	Flow Output Dest Addr	ACME	100
83	Flow Output Dest Port	ACME	101
84	RTCP Calling Packets Lost	ACME	104
85	RTCP Calling Avg Jitter (msec)	ACME	105
86	RTCP Calling Avg Latency (msec)	ACME	106
87	RTCP Calling Max Jitter (msec)	ACME	107
88	RTCP Calling Max Latency (msec)	ACME	108
89	RTP Calling Packets Lost	ACME	109
90	RTP Calling Avg Jitter (msec)	ACME	110
91	RTP Calling Max Jitter (msec)	ACME	111
92	RTP Calling Octets	ACME	102
93	RTP Calling Packets	ACME	103
94	Flow Identifier	ACME	112
95	Flow Type	ACME	113
96	Flow Input Realm	ACME	114
97	Flow Input Src Addr	ACME	115
98	Flow Input Src Port	ACME	116
99	Flow Input Dest Address	ACME	117
100	Flow Input Dest Port	ACME	118
101	Flow Output Realm	ACME	119
102	Flow Output Src Address	ACME	120
103	Flow Output Src Port	ACME	121
104	Flow Output Dest Addr	ACME	122
105	Flow Output Dest Port	ACME	123
106	RTCP Called Packets Lost	ACME	126
107	RTCP Called Avg Jitter (msec)	ACME	127
108	RTCP Called Avg Latency (msec)	ACME	128
109	RTCP Called Max Jitter (msec)	ACME	129
110	RTCP Called Max Latency (msec)	ACME	130

**Table B-7 (Cont.) Local CDR Stop Record (Diameter)**

<b>CSV Position</b>	<b>Attribute Name</b>	<b>Vendor</b>	<b>CDR Number</b>
111	RTP Called Packets Lost	ACME	131
112	RTP Called Avg Jitter (msec)	ACME	132
113	RTP Called Max Jitter (msec)	ACME	133
114	RTP Called Octets	ACME	124
115	RTP Called Packets	ACME	125
116	Charging Vector ICID	ACME	54
117	Charging Function Address	ACME	55
118	Firmware Version	ACME	56
119	Local timezone	ACME	57
120	Post Dial Delay (msec)	ACME	58
121	Primary routing Number	ACME	64
122	Originating Trunk Group	ACME	65
123	Terminating Trunk Group	ACME	66
124	Originating Trunk Context	ACME	67
125	Terminating Trunk Context	ACME	68
126	P Asserted ID	ACME	69
127	Ingress Local Address	ACME	74
128	Ingress Remote Address	ACME	75
129	Egress Local Address	ACME	76
130	Egress Remote Address	ACME	77
131	SIP DIVERSION	ACME	70
132	Session Disposition	ACME	60
133	Disconnect Initiator	ACME	61
134	Disconnect Cause	ACME	62
135	Sip Status Code	ACME	71
136	Egress Routing Number	ACME	134
137	Ingress RPH	ACME	135
138	Egress RPH	ACME	136
139	refer call transfer ID	ACME	141
140	Diam-Session-Id	ACME	172
141	Sip-Method	ACME	173
142	Event-Time	ACME	176
143	Content-Disposition	ACME	4119
144	Originator	ACME	4120
145	Subscription-ID-Data	ACME	4110
146	Subscription-ID-Type	ACME	4111
147	Service-Context-ID	ACME	4121
148	Called-Asserted-Identity	ACME	4117
149	SDP-Media	ACME	177
150	SDP-Type	ACME	4114
151	Served-Party-IP	ACME	4098
152	User-Name	ACME	4097
153	Node-Func	ACME	4100

**Table B-7 (Cont.) Local CDR Stop Record (Diameter)**

<b>CSV Position</b>	<b>Attribute Name</b>	<b>Vendor</b>	<b>CDR Number</b>
154	ApplicationId	ACME	4101
155	Role-Of-Node	ACME	4102
156	SIP-Request-Timestamp	ACME	4124
157	SIP-Request-Timestamp-Fraction	ACME	4112
158	SIP-Response-Timestamp	ACME	4125
159	SIP-Response-Timestamp-Fraction	ACME	4113
160	Access-Network-Information	ACME	248
161	Cause-Code	ACME	4099
162	Custom VSA 200	ACME	200
163	Custom VSA 201	ACME	201
164	Custom VSA 202	ACME	202
165	Custom VSA 203	ACME	203
166	Custom VSA 204	ACME	204
167	Custom VSA 205	ACME	205
168	Custom VSA 206	ACME	206
169	Custom VSA 207	ACME	207
170	Custom VSA 208	ACME	208
171	Custom VSA 209	ACME	209
172	Custom VSA 210	ACME	210
173	Custom VSA 211	ACME	211
174	Custom VSA 212	ACME	212
175	Custom VSA 213	ACME	213
176	Custom VSA 214	ACME	214
177	Custom VSA 215	ACME	215
178	Custom VSA 216	ACME	216
179	Custom VSA 217	ACME	217
180	Custom VSA 218	ACME	218
181	Custom VSA 219	ACME	219
182	Custom VSA 220	ACME	220
183	Custom VSA 221	ACME	221
184	Custom VSA 222	ACME	222
185	Custom VSA 223	ACME	223
186	Custom VSA 224	ACME	224
187	Custom VSA 225	ACME	225
188	Custom VSA 226	ACME	226
189	Custom VSA 227	ACME	227
190	Custom VSA 228	ACME	228
191	Custom VSA 229	ACME	229
192	Custom VSA 230	ACME	230
193	Calling-Media-Stop-Time	ACME	231
194	Called-Media-Stop-Time	ACME	232

**Table B-7 (Cont.) Local CDR Stop Record (Diameter)**

<b>CSV Position</b>	<b>Attribute Name</b>	<b>Vendor</b>	<b>CDR Number</b>
195	Calling-Media-Stop-Time	ACME	233
196	Called-Media-Stop-Time	ACME	234
197	Flow Media Type	ACME	142
198	Flow Media Type	ACME	143
199	Flow Media Type	ACME	144
200	Flow Media Type	ACME	145
201	RTP Calling Octets Transmitted	ACME	240
202	RTP Calling Packets Transmitted	ACME	241
203	RTP Called Octets Transmitted	ACME	242
204	RTP Called Packets Transmitted	ACME	243
205	RTP Calling Octets Transmitted	ACME	244
206	RTP Calling Packets Transmitted	ACME	245
207	RTP Calling Octets Transmitted	ACME	244
208	RTP Calling Packets Transmitted	ACME	245
209	MSRP Called Octets	ACME	249
210	MSRP Called Packets	ACME	249
211	MSRP Called Octets Transmitted	ACME	249
212	MSRP Called Packets Transmitted	ACME	249
213	MSRP Calling Octets	ACME	249
214	MSRP Calling Packets	ACME	249
215	MSRP Calling Octets Transmitted	ACME	249
216	MSRP Calling Packets Transmitted	ACME	249
217	PGW-IP Address	ACME	249
218	SGW-IP Address	ACME	249
219	ORIG-IOI	ACME	249
220	TERM-IOI	ACME	249
221	IMEI	ACME	249
222	Node Functionality	ACME	249
223	History Info	ACME	250
224	P-Visited Network ID	ACME	251
225	IMSI	ACME	252
226	Reason-Header	none	3401
227	CDR Sequence Number	ACME	59
228	Origin-Realm	ACME	4103
229	Origin-Host	ACME	4104
230	Destination-Realm	ACME	4105
231	Destination-Host	ACME	4106

**Table B-7 (Cont.) Local CDR Stop Record (Diameter)**

CSV Position	Attribute Name	Vendor	CDR Number
232	Stir-Signed-Request	ACME	249
233	Stir-Signed-Request-Exception-Id	ACME	249
234	Stir-Verified-Request	ACME	249
235	Stir-Verified-Request-Exception-Id	ACME	249
236	Stir-VS-Verstat	ACME	249
237	Stir-VS-Reason	ACME	249
238	Stir-TN-Used-For-AS-VS-Request	ACME	249
239	Stir-Div-Signed-Request	ACME	249
240	Stir-Div-Verified-Request	ACME	249
241	History Info2	ACME	253

## Local CDR Message Record for SMS (Diameter)

The SBC creates an Event CSV file for SMS messages when the generate-event = message parameter is enabled. The following table shows the inclusive CSV element order, when protocol = diameter.

**Table B-8 Local CDR Message Record (Diameter)**

CSV Placement	Attribute Name	Vendor	CDR Number
1	Accounting Status	none	40
2	NAS IP Address	none	4
3	NAS Port	none	5
4	Accounting Session ID	none	44
5	Ingress Session ID	ACME	3
6	Egress Session ID	ACME	4
7	Session Protocol Type	ACME	43
8	Session-Forked-Call-Id	ACME	171
9	Generic ID	ACME	40
10	Calling Station ID	none	31
11	Called Station ID	none	30
12	Egress Network Interface ID	ACME	137
13	Egress Vlan Tag Value	ACME	140
14	Ingress Network Interface ID	ACME	137
15	Ingress Vlan Tag Value	ACME	138
16	Cisco Setup Time	CISCO	25
17	Cisco Connect Time	CISCO	28
18	Diam-Session-Id	ACME	172
19	Sip-Method	ACME	173

Table B-8 (Cont.) Local CDR Message Record (Diameter)

CSV Placement	Attribute Name	Vendor	CDR Number
20	Event-Time	ACME	176
21	Content-Disposition	ACME	4119
22	Originator	ACME	4120
23	Subscription-ID-Data	ACME	4110
24	Subscription-ID-Type	ACME	4111
25	Service-Context-ID	ACME	4121
26	Called-Asserted-Identity	ACME	4117
27	User-Name	ACME	4097
28	Node-Func	ACME	4100
29	ApplicationId	ACME	4101
30	Role-Of-Node	ACME	4102
31	SIP-Request-Timestamp	ACME	4124
32	SIP-Request-Timestamp-Fraction	ACME	4112
33	SIP-Response-Timestamp	ACME	4125
34	SIP-Response-Timestamp-Fraction	ACME	4112
35	Access-Network-Information	ACME	248
36	Event	ACME	
37	Expires	ACME	
38	Associated-URI	ACME	
39	Cause-Code	ACME	
40	Custom VSA 200	ACME	200
41	Custom VSA 201	ACME	201
42	Custom VSA 202	ACME	202
43	Custom VSA 203	ACME	203
44	Custom VSA 204	ACME	204
45	Custom VSA 205	ACME	205
46	Custom VSA 206	ACME	206
47	Custom VSA 207	ACME	207
48	Custom VSA 208	ACME	208
49	Custom VSA 209	ACME	209
50	Custom VSA 210	ACME	210
51	Custom VSA 211	ACME	211
52	Custom VSA 212	ACME	212
53	Custom VSA 213	ACME	213
54	Custom VSA 214	ACME	214
55	Custom VSA 215	ACME	215
56	Custom VSA 216	ACME	216
57	Custom VSA 217	ACME	217
58	Custom VSA 218	ACME	218
59	Custom VSA 219	ACME	219
60	Custom VSA 220	ACME	220
61	Custom VSA 221	ACME	221
62	Custom VSA 222	ACME	222



**Table B-8 (Cont.) Local CDR Message Record (Diameter)**

<b>CSV Placement</b>	<b>Attribute Name</b>	<b>Vendor</b>	<b>CDR Number</b>
63	Custom VSA 223	ACME	223
64	Custom VSA 224	ACME	224
65	Custom VSA 225	ACME	225
66	Custom VSA 226	ACME	226
67	Custom VSA 227	ACME	227
68	Custom VSA 228	ACME	228
69	Custom VSA 229	ACME	229
70	Custom VSA 230	ACME	230
71	PGW-IP Address	ACME	249
72	SGW-IP Address	ACME	249
73	ORIG-IOI	ACME	249
74	TERM-IOI	ACME	249
75	IMEI	ACME	249
76	Node Functionality	ACME	249
77	Sms-Msg-Type	ACME	
78	Sms-Calling-Party-Number	ACME	
79	Sms-Called-Party-Number	ACME	
80	Sms-Msg-length	ACME	
81	P-Visited Network ID	ACME	251
82	IMSI	ACME	252
83	CDR Sequence Number	ACME	59
84	Origin-Realm	ACME	4103
85	Origin-Host	ACME	4104
86	Destination-Realm	ACME	4105
87	Destination-Host	ACME	4106

# C

## Oracle Rf Interface Support

The SBC supports numerous AVPs in its Diameter-based Rf implementation. Currently AVPs belong to:

- The Diameter base AVPs found in RFC3588 and RFC4006.
- For 3GPP AVPs, if not specified by this document, their definition follows corresponding 3GPP specifications.
- Oracle proprietary Rf AVPs. Please see Acme-Packet-Specific-Extension-Rf AVP.

### Diameter AVP Notation

3GPP 32.299 states the following symbols are used in the message format definitions:

<AVP> indicates a mandatory AVP with a fixed position in the message.

{AVP} indicates a mandatory AVP in the message.

[AVP] indicates an optional AVP in the message.

\*AVP indicates that multiple occurrences of an AVP is possible.

### Table Explanation

Each row in the following AVP tables contain:

- AVP Name
- AVP Number
- Reference where the AVP was defined
- Valid appearance in start, interim, stop, or event records
- For grouped AVPs, link to the group's respective section.

### Root ACR Message Format

The following table contains the top level AVPs that may be present in an SBC-generated message.

AVP	Number	Reference	Start	Interim	Stop	Event	Grouped
{ Session-Id }	263	Base	Y	Y	Y	Y	N/A
{ Origin-Host }	264	Base	Y	Y	Y	Y	N/A
{ Origin-Realm }	296	Base	Y	Y	Y	Y	N/A
{ Destination-Realm }	283	Base	Y	Y	Y	Y	N/A
{ Accounting-Record-Type }	480	Base	Y	Y	Y	Y	N/A

AVP	Number	Reference	Start	Interim	Stop	Event	Grouped
{ Accounting-Record-Number }	485	Base	Y	Y	Y	Y	N/A
[ Acct-Application-Id ]	259	Base	Y	Y	Y	Y	N/A
[ User-Name ]	1	Base	Y	Y	Y	Y	N/A
[ Origin-state-ID ]	278	Base	Y	Y	Y	Y	N/A
[ Event-Timestamp ]	55	Base	Y	Y	Y	Y	N/A
[ Service-Context-ID ]	461	3GPP	Y	Y	Y	Y	N/A
[ Service-Information ]	873	3GPP	Y	Y	Y	Y	Service-Information AVP
[ Acme-Packet-Specific-Extension-Rf ]	1	ACME	Y	Y	Y		Acme-Packet-Specific-Extension-Rf AVP

## Service Information AVP

The Service-Information AVP (AVP code 873) is of type Grouped.

AVP	Number	Reference	Start	Interim	Stop	Event	Grouped
[ Subscription-ID ]	443	3GPP	Y	Y	Y		Subscription ID AVP
[ IMS Information ]	876	3GPP	Y	Y	Y	Y	IMS Information AVP

## Subscription ID AVP

The Subscription ID AVP (AVP code 108) contains the identification of the user that is going to access the service in order to be identified by the OCS.

AVP	Number	Reference	Start	Interim	Stop	Event
[ Subscription-ID-Data ]	444	3GPP	Y	Y	Y	N/A
[ Subscription-ID-Type ]	450	3GPP	Y	Y	Y	N/A

## IMS Information AVP

The IMS-Information AVP (AVP code 876) is of type Grouped. Its purpose is to allow the transmission of additional IMS service specific information elements.

AVP	Number	Reference	Start	Interim	Stop	Event	Group
[ Event-Type ]	823	3GPP	Y	Y	Y	Y	Event-Type AVP
[ Role-of-Node ]	829	3GPP	Y	Y	Y	Y	N/A

AVP	Number	Reference	Start	Interim	Stop	Event	Group
{Node-Functionality}	862	3GPP	Y	Y	Y	Y	N/A
[ User-Session-Id ]	830	3GPP	Y	Y	Y	N/A	N/A
* [ Calling-Party-Address ]	831	3GPP	Y	Y	Y	Y	N/A
[ Called-Party-Address ]	832	3GPP	Y	Y	Y	Y	N/A
* [ Called-Asserted-Identity ]	1250	3GPP	Y	N/A	N/A	N/A	N/A
* [Associated-URI]	856	3GPP	N/A	N/A	N/A	Y	N/A
[ Time-Stamps]	833	3GPP	Y	Y	Y	Y	Time Stamps AVP
[ Inter-Operator-Identifier ]	838	3GPP	Y	Y	Y	N/A	Inter-Operator-Identifier AVP
*[ SDP-Session-Description ]	842	3GPP	Y	Y	N/A	N/A	N/A
*[ SDP-Media-Component ]	843	3GPP	Y	Y	N/A	N/A	SDP-Media-Component AVP
[IMS-Charging-Identifier]	841	3GPP	Y	Y	Y	N/A	N/A
*[ Early-Media-Description ]	1272	3GPP	Y	N/A	N/A	Y	Early-Media-Description AVP
*[ Message-Body ]	889	3GPP	Y	Y	Y	Y	Message-Body AVP
[ Served-Party-IP-Address ]	848	3GPP	Y*	Y*	Y*	N/A	N/A
[ Access-Network-Information ]	1263	N/A	Y	Y	Y	Y	N/A
[ Cause-Code ]	861	N/A	N/A	N/A	Y	Y	N/A

Y\*—This AVP appears if **sip-interface**, **sip-ims-feature** is set to **enabled**.

## Event-Type AVP

The Event-Type AVP (AVP code 823) is of type Grouped and contains information about the type of chargeable telecommunication service/event for which the accounting-request and/or credit control request message(s) is generated.

AVP	Number	Acme #	Reference	Start	Interim	Stop	Event
[ SIP-Method ]	824	173	3GPP	Y	Y	Y	Y
[ Event ]	825	245	3GPP	N/A	N/A	N/A	Y
[ Expires ]	888	246	3GPP	N/A	N/A	N/A	Y

## Time Stamps AVP

The Time-Stamps AVP (AVP code 833) is of type Grouped and holds the time of the initial SIP request and the time of the response to the initial SIP Request.

AVP	Number	Reference	Start	Interim	Stop	Event
[ SIP-Request-Timestamp ]	834	3GPP	Y	Y	Y	Y
[ SIP-Response-Timestamp ]	835	3GPP	Y*	Y	Y	Y
[ SIP-Request-Timestamp-Fraction ]	2301	3GPP	Y	Y	Y	Y
[ SIP-Response-Timestamp-Fraction ]	2302	3GPP	Y*	Y	Y	Y

Y\*—These AVPs appear in start records if **account-config, generate-start** is set to **OK**. If generate-start=invite, then they are not generated in the Start record.

## Inter-Operator-Identifier AVP

The Inter-Operator-Identifier AVP (AVP code 838) is of type Grouped and holds the identification of the network neighbors (originating and terminating) as exchanged via SIP signalling.

AVP	Number	Reference	Start	Interim	Stop	Event
[ Originating-IOI ]	839	3GPP	Y	Y	Y	N/A
[ Termination-IOI ]	840	3GPP	Y*	Y	Y	N/A

Y\*—These AVPs appear in start records if **account-config, generate-start** is set to **OK**.

## SDP-Media-Component AVP

The SDP- Media-Component AVP (AVP code 843) is of type Grouped and contains information about media used for a IMS session.

AVP	Number	Reference	Start	Interim	Stop	Event
[ SDP-Media-Name ]	844	3GPP	Y	Y	N/A	N/A
* [ SDP-Media-Description ]	845	3GPP	Y	Y	N/A	N/A
[ SDP-Type ]	2036	3GPP	Y	Y	N/A	N/A

## Early-Media-Description AVP

The Early-Media-Description AVP (AVP code 1272) is of type grouped and describes the SDP session, media parameters and timestamps related to media components set to active according to SDP signalling exchanged during a SIP session establishment before the final successful or unsuccessful SIP answer to the initial SIP INVITE message is received. Once a media component has been set to active, subsequent status changes shall also be registered.

AVP	Number	Reference	Start	Interim	Stop	Event	Group
[ SDP-TimeStamps ]	1273	3GPP	Y	N/A	N/A	Y	SDP-Timestamps AVP
*[ SDP-Session-Description ]	842	3GPP	Y	Y	N/A	N/A	N/A
*[ SDP-Media-Component ]	843	3GPP	Y	Y	N/A	N/A	SDP-Media-Component AVP

## SDP-Timestamps AVP

The SDP-TimeStamps AVP (AVP code 1273) is of type Grouped and holds the time of the SDP offer and the SDP answer.

AVP	Number	Reference	Start	Interim	Stop	Event
[ SDP-Offer-Timestamp ]	1274	N/A	Y	N/A	N/A	Y
[ SDP-Answer-Timestamp ]	1275	N/A	Y	N/A	N/A	Y

## Message-Body AVP

The Message-Body AVP (AVP Code 889) is of type Grouped AVP and holds information about the message bodies including user-to-user data.

AVP	Number	Reference	Start	Interim	Stop	Event
{ Content-Type }	826	3GPP	Y	Y	Y	Y
{ Content-Length }	827	3GPP	Y	Y	Y	Y
[ Content-Disposition ]	828	3GPP	Y	Y	Y	Y
[ Originator ]	864	3GPP	Y	Y	Y	Y

## Acme-Packet-Specific-Extension-Rf AVP

The Oracle Acme-Packet-Specific-Extension-Rf AVP uses vendor ID 9148. The following section includes the ACME AVP descriptions.

AVP	ACME Diameter Attribute	Start	Interim	Stop	Event	AVP Type
Ingress-Realm	2	Y	Y	Y	N	UTF8String
Egress-Realm	3	Y	Y	Y	N	UTF8String
Ingress-TGRP	4	Y	Y	Y	N	UTF8String
Egress-TGRP	5	Y	Y	Y	N	UTF8String
Ingress-Trunk-Context	6	Y	Y	Y	N	UTF8String
Egress-Trunk-Context	7	N	Y	Y	N	UTF8String
Ingress-Local-Signaling-Address	8	Y	Y	Y	N	UTF8String

AVP	ACME Diameter Attribute	Start	Interim	Stop	Event	AVP Type
Ingress-Remote-Signaling-Address	9	Y	Y	Y	N	UTF8String
Egress-Local-Signaling-Address	10	Y	Y	Y	N	UTF8String
Egress-Remote-Signaling-Address	11	Y	Y	Y	N	UTF8String
Ingress-Local-Media-Address	12	Y	Y	Y	N	UTF8String
Ingress-Remote-Media-Address	13	Y	Y	Y	N	UTF8String
Egress-Local-Media-Address	14	Y	Y	Y	N	UTF8String
Egress-Remote-Media-Address	15	Y	Y	Y	N	UTF8String
NAS-Port	16	Y	Y	Y	N	Unsigned32
Acme-Session-Ingress-CallID	17	Y	Y	Y	N	UTF8String
Acme-Session-Egress-CallID	18	Y	Y	Y	N	UTF8String
Acme-Session-Protocol-Type	19	Y	Y	Y	N	UTF8String
Acme-FlowID-FS1-F	20	Y	Y	Y	N	UTF8String
Acme-FlowType-FS1-F	21	Y	Y	Y	N	UTF8String
Ingress-Local-Media-Port	22	Y	Y	Y	N	Unsigned32
Ingress-Remote-Media-Port	23	Y	Y	Y	N	Unsigned32
Egress-Local-Media-Port	24	Y	Y	Y	N	Unsigned32
Egress-Remote-Media-Port	25	Y	Y	Y	N	Unsigned32
Acme-Session-Charging-Function-Address	26	Y	Y	Y	N	UTF8String
Acme-Local-Timezone	27	Y	Y	Y	N	UTF8String
Acme-Post-Dial-Delay	28	Y	Y	Y	N	Unsigned32
Acme-SIP-Diversion	29	Y	Y	Y	N	UTF8String
Acme-Session-Disposition	30	N	N	Y	N	Unsigned32
Disconnect-Initiator	31	N	N	Y	N	Unsigned32
Terminate-Cause	32	N	N	Y	N	Unsigned32
Acme-Session-Disconnect-Cause	33	N	N	Y	N	Unsigned32
Acme-SIP-Status	34	N	N	Y	N	Integer32

AVP	ACME Diameter Attribute	Start	Interim	Stop	Event	AVP Type
Acme-FlowType-FS1-R	35	N	Y	Y	N	UTF8String
Acme-Packet-Specific-Rf-QoS	37	N	N	Y	N	Grouped
RTP-Calling-Octets-FS1	38	N	N	Y	N	Unsigned32
RTP-Calling-Octets-FS2	39	N	N	Y	N	Unsigned32
RTP-Calling-Packets-FS1	40	N	N	Y	N	Unsigned32
RTP-Calling-Packets-FS2	41	N	N	Y	N	Unsigned32
RTP-Calling-Octets-Transmitted-FS1	42	N	N	Y	N	Unsigned32
RTP-Calling-Octets-Transmitted-FS2	43	N	N	Y	N	Unsigned32
RTP-Calling-Packets-Transmitted-FS1	44	N	N	Y	N	Unsigned32
RTP-Calling-Packets-Transmitted-FS2	45	N	N	Y	N	Unsigned32
RTP-Calling-Packets-Lost-FS1	46	N	N	Y	N	Unsigned32
RTP-Calling-Packets-Lost-FS2	47	N	N	Y	N	Unsigned32
RTP-Calling-Avg-Jitter-FS1	48	N	N	Y	N	Unsigned32
RTP-Calling-Avg-Jitter-FS2	49	N	N	Y	N	Unsigned32
RTP-Calling-Max-Jitter-FS1	50	N	N	Y	N	Unsigned32
RTP-Calling-Max-Jitter-FS2	51	N	N	Y	N	Unsigned32
RTCP-Calling-Packets-Lost-FS1	52	N	N	Y	N	Unsigned32
RTCP-Calling-Packets-Lost-FS2	53	N	N	Y	N	Unsigned32
RTCP-Calling-Avg-Jitter-FS1	54	N	N	Y	N	Unsigned32
RTCP-Calling-Avg-Jitter-FS2	55	N	N	Y	N	Unsigned32
RTCP-Calling-Avg-Latency-FS1	56	N	N	Y	N	Unsigned32
RTCP-Calling-Avg-Latency-FS2	57	N	N	Y	N	Unsigned32
RTCP-Calling-Max-Jitter-FS1	58	N	N	Y	N	Unsigned32



AVP	ACME Diameter Attribute	Start	Interim	Stop	Event	AVP Type
RTCP-Calling-Max-Jitter-FS2	59	N	N	Y	N	Unsigned32
RTCP-Calling-Max-Latency-FS1	60	N	N	Y	N	Unsigned32
RTCP-Calling-Max-Latency-FS2	61	N	N	Y	N	Unsigned32
RTP-Called-Octets-FS1	62	N	N	Y	N	Unsigned32
RTP-Called-Octets-FS2	63	N	N	Y	N	Unsigned32
RTP-Called-Packets-FS1	64	N	N	Y	N	Unsigned32
RTP-Called-Packets-FS2	65	N	N	Y	N	Unsigned32
RTP-Called-Octets-Transmitted-FS1	66	N	N	Y	N	Unsigned32
RTP-Called-Octets-Transmitted-FS2	67	N	N	Y	N	Unsigned32
RTP-Called-Packets-Transmitted-FS1	68	N	N	Y	N	Unsigned32
RTP-Called-Packets-Transmitted-FS2	69	N	N	Y	N	Unsigned32
RTP-Called-Packets-Lost-FS1	70	N	N	Y	N	Unsigned32
RTP-Called-Packets-Lost-FS2	71	N	N	Y	N	Unsigned32
RTP-Called-Avg-Jitter-FS1	72	N	N	Y	N	Unsigned32
RTP-Called-Avg-Jitter-FS2	73	N	N	Y	N	Unsigned32
RTP-Called-Max-Jitter-FS1	74	N	N	Y	N	Unsigned32
RTP-Called-Max-Jitter-FS2	75	N	N	Y	N	Unsigned32
RTCP-Called-Packets-Lost-FS1	76	N	N	Y	N	Unsigned32
RTCP-Called-Packets-Lost-FS2	77	N	N	Y	N	Unsigned32
RTCP-Called-Avg-Jitter-FS1	78	N	N	Y	N	Unsigned32
RTCP-Called-Avg-Jitter-FS2	79	N	N	Y	N	Unsigned32
RTCP-Called-Avg-Latency-FS1	80	N	N	Y	N	Unsigned32
RTCP-Called-Avg-Latency-FS2	81	N	N	Y	N	Unsigned32

AVP	ACME Diameter Attribute	Start	Interim	Stop	Event	AVP Type
RTCP-Called-Max-Jitter-FS1	82	N	N	Y	N	Unsigned32
RTCP-Called-Max-Jitter-FS2	83	N	N	Y	N	Unsigned32
RTCP-Called-Max-Latency-FS1	84	N	N	Y	N	Unsigned32
RTCP-Called-Max-Latency-FS2	85	N	N	Y	N	Unsigned32
Acme-Packets-Specific-MSRP-STATS	86	N	N	Y	N	Grouped
MSRP-Calling-Packets-Received	87	N	N	Y	N	Unsigned32
MSRP-Calling-Octets-Received	88	N	N	Y	N	Unsigned32
MSRP-Calling-Packets-Transmitted	89	N	N	Y	N	Unsigned32
MSRP-Calling-Octets-Transmitted	90	N	N	Y	N	Unsigned32
MSRP-Called-Packets-Received	91	N	N	Y	N	Unsigned32
MSRP-Called-Octets-Received	92	N	N	Y	N	Unsigned32
MSRP-Called-Packets-Transmitted	93	N	N	Y	N	Unsigned32
MSRP-Called-Octets-Transmitted	94	N	N	Y	N	Unsigned32
Stir-VS-Verstat	108	Y	Y	Y	Y	UTF8String
Stir-VS-Reason	109	Y	Y	Y	Y	String
Stir-TN-Used-For-AS-VSRequest	110	Y	Y	Y	Y	String
Stir-Div-Signed-Request	111	Y (if generate-start=OK)	Y	Y	Y	String
Stir-Div-Verified-Request	112	Y	Y	Y	Y	String
Acme-FlowIDFS1-R	113	Y	Y	Y	N	UTF8String
Acme-FlowIDFS2-F	114	Y	Y	Y	N	UTF8String
Acme-FlowIDFS2-R	115	Y	Y	Y	N	UTF8String
Acme-FlowType-FS2-F	116	Y	Y	Y	N	UTF8String
Acme-FlowType-FS2-R	117	Y	Y	Y	N	UTF8String

## AVP Definitions

The following table lists and briefly describes the Acme-Packet-Specific-Extension-Rf AVPs.

AVP	Definition
Ingress-Realm	realm of origination
Egress-Realm	realm of termination
Ingress-TGRP	TGRP received
Egress-TGRP	TGRP sent
Ingress-Trunk-Context	trunk context received
Egress-Trunk-Context	trunk context sent
Ingress-Local-Signaling-Address	Signaling address of P-CSCF that received the request from the remote element
Ingress-Remote-Signaling-Address	Signaling address of the remote element that sent the request to the P-CSCF
Egress-Local-Signaling-Address	Signaling address of P-CSCF that sent the request to the remote element
Egress-Remote-Signaling-Address	signaling address of the remote element that received the request from the P-CSCF
Ingress-Local-Media-Address	media address of P-CSCF on the originating side
Ingress-Remote-Media-Address	media address of the remote element on the originating side
Egress-Local-Media-Address	media address of P-CSCF on the terminating side
Egress-Remote-Media-Address	media address of the remote element on the terminating side
NAS-Port	SIP proxy port or the H.323 stack's call signaling RAS port.
Acme-Session-Ingress-CallID	Call ID generated by the originating device.
Acme-Session-Egress-CallID	Call ID generated by the SBC to represent a two-way transaction.
Acme-Session-Protocol-Type	Signaling protocol used for a particular leg of a session (in the case of IWF, there may be two legs). This attribute contains the signaling protocol type; for example, SIP or H323.
Acme-FlowID-FS1-F	Unique identifier for every media flow processed by the SBC, flow-set 1 forward direction.
Acme-FlowID-FS1-R	Unique identifier for every media flow processed by the OCSBC, flow-set 1 reverse direction.
Acme-FlowType-FS1-F	Codec that describes the flow, flow-set 1 forward direction: PCMU, PCMA, G726, G723, G728, G729, H261, H263, T38.
Acme-FlowID-FS2-F	Unique identifier for every media flow processed by the OCSBC, flow-set 2 forward direction.
Acme-FlowID-FS2-R	Unique identifier for every media flow processed by the OCSBC, flow-set 2 reverse direction.

AVP	Definition
Acme-FlowType-FS2-F	Codec that describes the flow, flow-set 2 forward direction: PCMU, PCMA, G726, G723, G728,G729, H261, H263, T38.
Acme-FlowType-FS2-R	Codec that describes the flow, flow-set 2 reverse direction: PCMU, PCMA, G726, G723, G728,G729, H261, H263, T38.
Ingress-Local-Media-Port	Ingress port portion of address of P-CSCF on the originating side
Ingress-Remote-Media-Port	Ingress port portion of media address of the remote element on the originating side
Egress-Local-Media-Port	Egress port portion of address of P-CSCF on the terminating side
Egress-Remote-Media-Port	Egress port portion of media address of the remote element on the terminating side
Acme-Session-Charging-Function-Address	The latest cached copy or the configured ccf-address.
Acme-Local-Timezone	Local GMT/UTC time zone that is provisioned on the SBC.
Acme-Post-Dial-Delay	Amount of time between session initiation and an alerting event.
Acme-SIP-Diversion	SIP Diversion header; communicates to the called party from whom and why a call diverted.
Acme-Session-Disposition	Status of the call attempt as it progresses from being initiated (using a SIP INVITE or H.323 Setup message) to being either answered or failing to be answered.
Disconnect-Initiator	Initiator of a call disconnect.
Terminate-Cause	Reason for session ending (refer to Session Termination session).
Acme-Session-Disconnect-Cause	Q.850 cause code value.
Acme-SIP-Status	SIP status code for RFC 3326 support.
Acme-FlowType-FS1-R	Codec that describes the flow, flow-set 1 reverse direction: PCMU, PCMA, G726, G723, G728, G729, H261, H263, T38.
RTP-Calling-Octets-FS1	RTP total calling octets for stream 1
RTP-Calling-Octets-FS2	RTP total calling octets for stream 2
RTP-Calling-Packets-FS1	RTP total calling packets for stream 1
RTP-Calling-Packets-FS2	RTP total calling packets for stream 2
RTP-Calling-Octets-Transmitted-FS1	RTP calling octets transmitted for stream 1
RTP-Calling-Octets-Transmitted-FS2	RTP calling octets transmitted for stream 2
RTP-Calling-Packet-Transmitted-FS1	RTP calling packets transmitted for stream 1
RTP-Calling-Packet-Transmitted-FS2	RTP calling packets transmitted for stream 2
RTP-Calling-Packets-Lost-FS1	RTP calling packets lost for stream 1
RTP-Calling-Packets-Lost-FS2	RTP calling packets lost for stream 2
RTP-Calling-Avg-Jitter-FS1	RTP calling average jitter rate for stream 1
RTP-Calling-Avg-Jitter-FS2	RTP calling average jitter rate for stream 2
RTP-Calling-Max-Jitter-FS1	RTP calling maximum jitter rate for stream 1
RTP-Calling-Max-Jitter-FS2	RTP calling maximum jitter rate for stream 2

AVP	Definition
RTCP-Calling-Packets-Lost-FS1	RTCP calling packet lost rate for stream 1
RTCP-Calling-Packets-Lost-FS2	RTCP calling packet lost rate for stream 2
RTCP-Calling-Avg-Jitter-FS1	RTCP calling average jitter rate for stream 1
RTCP-Calling-Avg-Jitter-FS2	RTCP calling average jitter rate for stream 2
RTCP-Calling-Avg-Latency-FS1	RTCP calling average latency for stream 1
RTCP-Calling-Avg-Latency-FS2	RTCP calling average latency for stream 2
RTCP-Calling-Max-Jitter-FS1	RTCP calling maximum jitter rate for stream 1
RTCP-Calling-Max-Jitter-FS2	RTCP calling maximum jitter rate for stream 2
RTCP-Calling-Max-Latency-FS1	RTCP calling maximum latency rate for stream 1
RTCP-Calling-Max-Latency-FS2	RTCP calling maximum latency rate for stream 2
RTP-Called-Octets-FS1	RTP called total octets for stream 1
RTP-Called-Octets-FS2	RTP called total octets for stream 2
RTP-Called-Packets-FS1	RTP called total packets for stream 1
RTP-Called-Packets-FS2	RTP called total packets for stream 2
RTP-Called-Octets-Transmitted-FS1	RTP called octets transmitted for stream 1
RTP-Called-Octets-Transmitted-FS2	RTP called octets transmitted for stream 2
RTP-Called-Packets-Transmitted-FS1	RTP called packets transmitted for stream 1
RTP-Called-Packets-Transmitted-FS2	RTP called packets transmitted for stream 2
RTP-Called-Packets-Lost-FS1	RTP called packets lost for stream 1
RTP-Called-Packets-Lost-FS2	RTP called packets lost for stream 2
RTP-Called-Avg-Jitter-FS1	RTP called average jitter for stream 1
RTP-Called-Avg-Jitter-FS2	RTP called average jitter for stream 2
RTP-Called-Max-Jitter-FS1	RTP called maximum jitter for stream 1
RTP-Called-Max-Jitter-FS2	RTP called maximum jitter for stream 2
RTCP-Called-Packets-Lost-FS1	RTCP called packets lost for stream 1
RTCP-Called-Packets-Lost-FS2	RTCP called packets lost for stream 2
RTCP-Called-Avg-Jitter-FS1	RTCP called average jitter for stream 1
RTCP-Called-Avg-Jitter-FS2	RTCP called average jitter for stream 2
RTCP-Called-Avg-Latency-FS1	RTCP called average latency for stream 1
RTCP-Called-Avg-Latency-FS2	RTCP called average latency for stream 2
RTCP-Called-Max-Jitter-FS1	RTCP called maximum jitter for stream 1
RTCP-Called-Max-Jitter-FS2	RTCP called maximum jitter for stream 2
RTCP-Called-Max-Latency-FS1	RTCP called maximum latency for stream 1
RTCP-Called-Max-Latency-FS2	RTCP called maximum latency for stream 2
Acme-MSRP-Calling-Packets-Received	Total MSRP calling packets
Acme-MSRP-Calling-Octets-Received	Total MSRP calling octets
Acme-MSRP-Calling-Packets-Transmitted	Total MSRP calling transmitted packets
Acme-MSRP-Calling-Octets-Transmitted	Total MSRP calling transmitted octets
Acme-MSRP-Called-Packets-Received	Total MSRP called packets
Acme-MSRP-Called-Octets-Received	Total MSRP called octets
Acme-MSRP-Called-Packets-Transmitted	Total MSRP called transmitted packets
Acme-MSRP-Called-Octets-Transmitted	Total MSRP called transmitted octets

## System Alarming Based on Received Result-Code (268) AVP

All non-success (non 2xxx) result codes received are logged and the SBC raises an internal minor alarm, sending the apDiameterSrvrErrorResultTrap SNMP trap to any configured trap receiver for the following values in the ACA message's Result-Code (268) AVP:

- 3002
- 3004
- 4002
- 5012

For more information, see the *MIB Reference Guide*. The SBC uses DWR mechanism for failover purposes - not based on result codes.

The SBC expects this AVP in an ACA message to follow:

AVP	Number	AVP Type	Reference	Start	Interim	Stop	Event
[ Result-Code ]	268	Unsigned32	Base	Y	Y	Y	Y

## Interim ACR Message Creation Interval per Acct-Interim-Interval AVP

The ACA message's Acct-Interim-Interval AVP (85) indicates the interval at which the SBC sends INTERIM ACR messages. The value provided in the CCF's ACA overrides any configured Acct-Interim-Interval in the network element.

The SBC expects this AVP in an ACA message to follow:

AVP	Number	AVP Type	Reference	Start	Interim	Stop	Event
[ Acct-Interim-Interval AVP ]	85	Unsigned32	Base	Y	Y	Y	Y