

# Oracle Financial Services

## Accounting Foundation Cloud Service Core Functions



Release 26B

G55804-03

May 2026

The Oracle logo, consisting of a solid red square with the word "ORACLE" in white, uppercase, sans-serif font centered within it.

ORACLE®

Oracle Financial Services Accounting Foundation Cloud Service Core Functions, Release 26B

G55804-03

Copyright © 2022, 2026, Oracle and/or its affiliates.

This software and related documentation are provided under a license agreement containing restrictions on use and disclosure and are protected by intellectual property laws. Except as expressly permitted in your license agreement or allowed by law, you may not use, copy, reproduce, translate, broadcast, modify, license, transmit, distribute, exhibit, perform, publish, or display any part, in any form, or by any means. Reverse engineering, disassembly, or decompilation of this software, unless required by law for interoperability, is prohibited.

The information contained herein is subject to change without notice and is not warranted to be error-free. If you find any errors, please report them to us in writing.

If this is software, software documentation, data (as defined in the Federal Acquisition Regulation), or related documentation that is delivered to the U.S. Government or anyone licensing it on behalf of the U.S. Government, then the following notice is applicable:

U.S. GOVERNMENT END USERS: Oracle programs (including any operating system, integrated software, any programs embedded, installed, or activated on delivered hardware, and modifications of such programs) and Oracle computer documentation or other Oracle data delivered to or accessed by U.S. Government end users are "commercial computer software," "commercial computer software documentation," or "limited rights data" pursuant to the applicable Federal Acquisition Regulation and agency-specific supplemental regulations. As such, the use, reproduction, duplication, release, display, disclosure, modification, preparation of derivative works, and/or adaptation of i) Oracle programs (including any operating system, integrated software, any programs embedded, installed, or activated on delivered hardware, and modifications of such programs), ii) Oracle computer documentation and/or iii) other Oracle data, is subject to the rights and limitations specified in the license contained in the applicable contract. The terms governing the U.S. Government's use of Oracle cloud services are defined by the applicable contract for such services. No other rights are granted to the U.S. Government.

This software or hardware is developed for general use in a variety of information management applications. It is not developed or intended for use in any inherently dangerous applications, including applications that may create a risk of personal injury. If you use this software or hardware in dangerous applications, then you shall be responsible to take all appropriate fail-safe, backup, redundancy, and other measures to ensure its safe use. Oracle Corporation and its affiliates disclaim any liability for any damages caused by use of this software or hardware in dangerous applications.

Oracle®, Java, MySQL, and NetSuite are registered trademarks of Oracle and/or its affiliates. Other names may be trademarks of their respective owners.

Intel and Intel Inside are trademarks or registered trademarks of Intel Corporation. All SPARC trademarks are used under license and are trademarks or registered trademarks of SPARC International, Inc. AMD, Epyc, and the AMD logo are trademarks or registered trademarks of Advanced Micro Devices. UNIX is a registered trademark of The Open Group.

This software or hardware and documentation may provide access to or information about content, products, and services from third parties. Oracle Corporation and its affiliates are not responsible for and expressly disclaim all warranties of any kind with respect to third-party content, products, and services unless otherwise set forth in an applicable agreement between you and Oracle. Oracle Corporation and its affiliates will not be responsible for any loss, costs, or damages incurred due to your access to or use of third-party content, products, or services, except as set forth in an applicable agreement between you and Oracle.

# Contents

1	Revision History	
2	Get Help	
2.1	Access Help Content	1
2.1.1	Watch Video	1
2.1.2	Additional Resources	1
2.2	Learn About Accessibility	1
2.3	Get Support	1
2.4	Get Training	2
2.5	Join Our Community	2
2.6	Share Your Feedback	2
3	About Accounting Foundation Cloud Service	
4	About Accounting Foundation Cloud Service- Standard Edition	
5	Accessing the Accounting Foundation Cloud Service	
6	Post Upgrade Steps	
7	Viewing the System Information	
8	Setting Up Your Service	
8.1	Domain	1
8.1.1	Select your Domain	1
8.1.2	Add Domain	1
8.1.3	Deploy the Domain	2

8.2	Legal Entity	3
8.2.1	Legal Entity Settings	3
8.3	Fiscal Period	3
8.3.1	Set Up Fiscal Periods	4
8.3.2	Compile Fiscal Periods	5
8.4	Configure Parameters	5
8.4.1	Accessing Parameters	5
8.4.2	Parameter Settings	5
8.4.3	Defining a Parameter	6
8.4.4	Modifying and Viewing a Parameter	6
8.4.5	Deleting a Parameter	6
8.4.6	Dependency	7

## 9 Managing Users and Entitlements

---

## 10 Creating Custom User Groups Using IAM Console

---

10.1	Accessing Admin Console User Interface	3
------	--	---

## 11 Connecting to your Oracle ERP Service

---

11.1	AHCS Instance Details	1
11.1.1	Configure ERP Settings	1
11.2	Verification of ERP Settings	3

## 12 Configuring Accounting Content

---

12.1	Sub Ledger Application Definition	1
12.1.1	Subledger Application Summary	1
12.1.2	Pre-packaged Subledgers	3
12.2	Adding a Subledger Application	4
12.3	Event and Journal Grouping	8
12.4	Subledger Attributes	8
12.4.1	Adding a Subledger Attribute	9
12.4.2	Modifying a Subledger Attribute	9
12.4.2.1	Re-registration of Attributes in a Custom SLA	10

## 13 Registering Accounting Content with your ERP Service

---

13.1	Registration of SLAs with Accounting Hub Service	1
13.2	Configuring an SLA	3
13.2.1	Ledger Name Assignment	3

13.3	Publishing SLAs	3
13.4	Ledger Configuration	4
13.5	Unpublishing SLAs	7
13.6	Segment Mapping	7
13.6.1	Mapping Segments	10
13.6.2	Publishing COA or ML Segments	10
13.7	Accounting Balance Ingestion	11
13.7.1	Prerequisite	12
13.7.2	GL Balances Process	12
13.7.3	Executing GL Balances Process	12
13.8	Journal Ingestion	12
13.8.1	Prerequisite	13
13.8.2	ERP Journal Ingestion Process	13
13.8.3	Executing ERP Journal Ingestion Process	14
13.9	Copying a Subledger Application	14
13.10	Executing the SLA Pipelines	14
13.10.1	Prerequisite	15
13.10.2	SLA Pipeline Process	15
13.10.3	Executing SLA	15
13.11	Integration with Oracle Applications	16
13.11.1	Integration with Oracle Enterprise Data Management Cloud Service	16
13.11.1.1	Pre-Configured Standard Dimensions	16
13.11.1.2	Validations in EDMCS	17
13.11.1.3	Managing Dimensions and Hierarchies in EDMCS	17
13.11.1.4	Steps for Integrating EDMCS with AFCS	22

## 14 SLA Configuration Using New User Interface

---

14.1	Creating an SLA in the New User Interface	1
14.2	Publishing an SLA Using New User Interface	4
14.3	Unpublishing an SLA Using New User Interface	4
14.4	Copying an existing SLA in the New User Interface	5
14.5	Deleting an SLA in the New User Interface	5

## 15 Managing Data Catalog

---

15.1	Accessing the Catalog	1
15.2	Viewing Catalog Content	1
15.3	Extending Catalog Content	2

# 16 Managing Data

---

16.1	File Operations	1
16.2	Data Ingress	2
16.2.1	External Data Descriptor	2
16.2.1.1	Data Tab	2
16.2.1.2	Control Tab	5
16.2.1.3	Transformation Tab	8
16.2.1.4	Defining an External Data Descriptor	9
16.2.1.5	Modifying and Viewing an External Data Descriptor	10
16.2.1.6	Deleting an External Data Descriptor	10
16.2.1.7	Search and Filter	10
16.2.1.8	Parameters in EDD Definition	10
16.2.2	Catalog Lookup Object	11
16.2.2.1	Defining a Catalog Lookup Object	11
16.2.2.2	Viewing a Catalog Lookup	12
16.2.2.3	Search for Catalog Lookup	13
16.2.2.4	Catalog Lookup Summary	13
16.2.3	Data File Encryption	13
16.2.3.1	Configuring Administrator Key for Data File Encryption	13
16.2.3.2	External Data Descriptor - Encrypted Files	14
16.2.3.3	Troubleshooting Encryption Error	14
16.3	Data Egress	15
16.3.1	Connectors	15
16.3.1.1	Icons and Description	15
16.3.2	Creating Connectors	16
16.3.3	Ingesting Data into AFCS	16
16.3.4	Filter	18
16.3.5	Join	19
16.3.6	Lookup	19
16.3.7	Aggregation	20
16.3.8	Reference Identifier Generator	20
16.3.9	Transpose (Rows to Columns)	21
16.3.10	Transpose (Columns to Rows)	21
16.3.11	Derived Column	22
16.3.12	Connect	22
16.3.13	Flattened Table to Hierarchy	23
16.3.14	Hierarchy Data Flattening	24
16.3.15	Specifying Alias in Connector	24
16.3.16	Modifying and Viewing a Connector	25
16.3.17	Copying a Connector	25
16.3.18	Deleting a Connector	25

16.3.19	Search and Filter	25
16.3.20	Parameters in Connector	25
16.3.21	Using Target Rejection Threshold	26
16.3.21.1	Reading the Error Table	27
16.3.22	Executing Connectors	27
16.3.22.1	Executing Connector Using Process Modelling Framework	27
16.3.22.2	Specifying Runtime Parameters	27
16.4	Quality	28
16.5	Dimensions	28
16.6	Hierarchy Management	28
16.7	Reporting Parent-Child Data Population	29
16.8	Data Maintenance Interface	30
16.8.1	Configuring Data Maintenance Forms	31
16.8.2	Creating New Forms	32
16.8.2.1	Configuring Data Entry	32
16.8.2.2	Configuring Excel Upload	35
16.8.2.3	Approving and Rejecting New Form Definitions	38
16.8.3	Managing Form Definitions	39
16.8.3.1	Viewing Form Definitions	40
16.8.3.2	Creating Issue and Action for DMI	40
16.8.3.3	Editing/Amending Form Definitions	40
16.8.3.4	Copying Form Definitions	41
16.8.3.5	Deleting Form Definitions	42
16.9	Protection	42
16.9.1	Data Redaction	42

## 17 Managing Processes

---

17.1	Key Features of Process Orchestration	1
17.2	Process Pipeline Flow	2
17.3	Access Process Orchestration	2
17.4	Access Process Orchestration for New User Interface	3
17.5	Designing and Executing Pipelines for New User Interface	4
17.5.1	Process Modeler for the New User Interface	4
17.5.2	Canvas and Components for New User Interface	4
17.5.2.1	How to Use a Service Task in the New User Interface	5
17.5.2.2	Executing Parallel Tasks	6
17.5.2.3	How to Use a Widget in the New User Interface	7
17.5.3	Run Pipeline for the New User Interface	8
17.5.3.1	Creating a Run Pipeline in the New User Interface	8
17.5.4	Add a Data Field from the New User Interface	13
17.5.5	Executing Run Pipeline from the New User Interface	13

17.5.6	PMF Dashboard for New User Interface	15
17.5.6.1	View and Filter PMF Dashboard for the New User Interface	15
17.5.6.2	Exporting PMF Dashboard Report	17
17.5.7	Scheduler Services for a PMF Process	18
17.5.8	Process Monitor for the New User Interface	18
17.5.8.1	Monitoring a Process from the New User Interface	19
17.6	Designing and Executing Pipelines	19
17.6.1	Process Modeller	19
17.6.2	Canvas and Components	20
17.6.2.1	Service Task	20
17.6.2.2	Transition	21
17.6.2.3	Connector	24
17.6.2.4	Widgets	24
17.6.3	Design a Pipeline	34
17.6.3.1	Run Pipeline	34
17.6.3.2	Additional Functionalities	36
17.6.4	Data Fields	37
17.6.4.1	Add a Data Field	37
17.6.4.2	System Data Fields	38
17.6.5	Executing Run Pipeline	38
17.6.6	PMF Dashboard	38
17.6.6.1	View and Filter PMF Dashboard	39
17.6.6.2	Exporting PMF Dashboard Report	40
17.6.6.3	PMF- Error Codes and Descriptions	41
17.6.7	PMF Email Notification	42
17.6.7.1	PMF Email Notification at Package or Process Level	42
17.6.7.2	PMF Email Notification at User Level	42
17.6.7.3	PMF Email Notification Template	43
17.6.8	Process Monitor	44
17.6.8.1	Monitoring a Process	44
17.6.8.2	Viewing Activity Execution Logs	44
17.6.9	Abort Run Pipeline	45
17.6.10	Resume Run Pipeline	45
17.6.11	Re-run Run Pipeline	46
17.7	Appendix- Application Rules	46
17.7.1	Decision Rule	46
17.7.1.1	Expression Application Rule	46
17.7.1.2	Attribute Expression Application Rule	48

# 18 Balance Computation

---

18.1	Currency Exchange Rates	1
18.1.1	About Currency Exchange Rates	1
18.1.2	Staging	2
18.1.2.1	Currency Exchange Rates at Time Granularity	2
18.1.2.2	Currency Rate Type with Seeded List of Values	2
18.1.2.3	Currency Rate Nature with Seeded List of Values	2
18.1.3	Preparation	3
18.1.4	Currency Exchange Rates Workflow	3
18.2	Currency Conversion	5
18.3	Period to Date Balance	6
18.4	Period to Date Average	6
18.4.1	Use and Execute the Balance Computation Management Ledger Process	6
18.5	PMF Dashboard for Balance Computation	10
18.5.1	PMF Dashboard Error Codes and Descriptions for Balance Computation Engine	10
18.6	Hierarchy Data Refresh for Balance Computation Engine	14
18.7	Balance Computation Management Ledger Initialization	17
18.7.1	Use and Execute Balance Computation Management Ledger Initialization Pipeline	17
18.8	Revaluation	18
18.8.1	Revaluation Basis	20
18.8.2	Creating Revaluation Rule ESS Job for AFCS	20
18.8.3	Revaluation-ML Segments Default Value for Unrealised Gain and Loss Figures	22
18.8.3.1	Configuring Management Ledger Segments to Default Value	23
18.8.4	Use and Execute Revaluation Preparation Pipeline	23
18.8.5	Use and Execute Persist Segment Combinations Pipeline	25
18.8.6	Use and Execute the Revaluation Process	26
18.8.7	Use and Execute the Balance Revaluation Retrospective Management Ledger Process	30
18.9	Revaluation Reversals	34
18.9.1	Use and Execute Beginning of the Day Balance Computation Management Ledger Pipeline	35
18.10	Balance Computation Management Ledger Data Compaction Pipeline	37
18.10.1	Use and Execute Balance Computation Management Ledger Data Compaction Pipeline	37
18.11	Translation	38
18.12	Support for Restatement	39
18.12.1	Overview	39
18.12.1.1	Data Identification Criteria	39
18.12.1.2	Process Details	39
18.13	Data Extraction for Management Ledger Period Balances	41

18.14	Data for Balance Reconciliation of Management Ledger Period Balances	41
18.15	Initial Instrument - Grain Accounting Balance for Management Ledger	41
18.15.1	Ingest Initial Balance	42
18.15.2	Processing History Prior to Live Production Use	43

## 19 Balance Reconciliation

---

19.1	Measures List	3
19.1.1	Enable Custom Measures	7
19.2	Before you Begin	8
19.3	Access Balance Reconciliation UI	8
19.4	Configure Type of Reconciliation	8
19.4.1	Type Configuration	9
19.4.1.1	General Ledger to Product Processor	9
19.4.1.2	General Ledger to Management Ledger	11
19.4.1.3	Management Ledger to Product Processor	14
19.4.1.4	General Ledger to Policy	17
19.4.1.5	Management Ledger to Policy	18
19.5	Configure Entity	20
19.5.1	Entity Configuration	20
19.6	Reconciliation Rules	21
19.6.1	Define Reconciliation Rules	21
19.6.1.1	Reconciliation Rule	22
19.6.1.2	Search Reconciliation Rule	23
19.6.1.3	Add a Reconciliation Definition	23
19.6.2	Execution of Rule	30
19.6.2.1	Prerequisite	30
19.6.2.2	Process Modeller	31
19.6.2.3	Process Monitor	36
19.6.3	Reconciliation Summary	36
19.6.3.1	Exporting Adjustments	37
19.6.3.2	Importing Adjustments	37
19.6.3.3	Publishing	38
19.7	Configure Adjustments	38
19.7.1	Adjustments Summary	39
19.7.2	Search Adjustment Rule	39
19.7.3	Add Adjustment Template	39
19.7.4	Update Adjustment Template	40
19.8	PMF Dashboard for Balance Reconciliation	40
19.8.1	PMF Dashboard Error Codes and Descriptions for Balance Reconciliation	40
19.9	Hierarchy Configuration for Reconciliation	41

## 20 Information Access Control

---

20.1	Configuring Dimensions for IAC	1
20.2	Managing Data Access Rules	2
20.3	Mapping Users to IAC User Groups	3
20.4	Information Access Control PMF Execution	4

## 21 Issues and Actions

---

21.1	Issues	1
21.2	Actions	1
21.3	Tracking and Work flow	1
21.3.1	Manage an Issue	1
21.3.1.1	Create or Log an Issue	1
21.3.1.2	Update an Issue	2
21.3.1.3	Close an Issue	3
21.3.1.4	Reopen an Issue	3
21.3.1.5	Delete an Issue	3
21.3.2	Manage an Action	4
21.3.2.1	Create an Action	4
21.3.2.2	Update an Action	5
21.3.2.3	Approval Work flow for Issues and Actions	6
21.3.3	Create or Update a Business Term	8

## 22 Dashboards and Reports

---

22.1	Overview of Balance Reconciliation Reports and Dashboards	1
22.1.1	Accessing the Standard Reports and Dashboards	2
22.1.1.1	Report Descriptions	3
22.2	Reporting Custom Mapping	12
22.2.1	Custom Dimensions	13
	Add Custom Attributes in Custom Dimension	14
22.2.2	Custom Attributes for OOB Tables	15
22.2.3	Custom Hierarchies	16
22.3	Balance Computation Engine	18
22.4	Balance Computation Results	19
22.4.1	Accessing the Standard Reports and Dashboards	19
22.4.2	Report Descriptions	20
22.4.2.1	Dashboard: Period to Date	20
22.4.2.2	Dashboard: Period to Date History	22

22.4.2.3	Dashboard: Ledger Sets	24
22.5	Data Quality Results	26
22.5.1	Accessing the Standard Reports and Dashboards	26
22.5.2	Report Descriptions	27
22.5.2.1	Data Quality Results	27
22.6	Data Visualization	30
22.6.1	Access to Data via Data Visualization	31
22.6.1.1	User Roles	31
22.6.2	Accessing the Data Visualization Reports	31
22.6.3	Data Quality for Data Visualization Reports	32
22.6.4	Creating Dataset to View the Custom Attributes in Data Visualization	32
22.6.5	Data Ingestion Query	33
22.6.6	Accessing the Usage Tracking Reports	34
22.7	Business Intelligence Publisher	35
22.7.1	Access to Business Intelligence Publisher	35
22.7.2	Creating Data Model to Generate BIP Report	36
22.8	Accounting Entries Report	36
22.8.1	Accessing the Standard Reports and Dashboards	37
22.8.2	Report Descriptions	37
22.8.2.1	Accounting Journals	37
22.8.2.2	Revaluation Entries	40
22.8.2.3	Revaluation Execution	41
22.9	Account Summary	42
22.9.1	Accessing the Standard Reports and Dashboards	43
22.9.1.1	Report Descriptions	43
22.10	Transaction Summary	44
22.10.1	Accessing the Standard Reports and Dashboards	44
22.10.1.1	Report Descriptions	45
22.11	Drill Back Capability	46
22.11.1	Accounting Journals and Transaction Summary	47
22.11.2	Transaction Details Report	48
22.12	Fact Common Policy Summary	49

## 23 Data Extraction

---

23.1	Adding a Data Extraction	1
23.2	OOTB Extract for Management Ledger	4
23.3	OOTB Extract for Management Ledger As Of Date	7
23.4	OOTB Extract for Management Ledger As Of Effective Date	10
23.5	Extracting the maximum version of ML balances	12
23.6	OOTB Extract for Data Quality Error Report	14
23.6.1	Extracting the Data Quality Error Records	16

23.7	OOTB Extract for Period Day YTD Balance	16
23.7.1	Prerequisite	16
23.7.2	Period Day YTD Balance Extraction Process	17
23.7.3	Executing Period Day YTD Balance Extraction Process	17
23.7.4	Incremental Extract for Period Day YTD Balance	17
23.7.4.1	Prerequisite	17
23.7.4.2	Configuring the Incremental PTD Balance Process	17
23.7.4.3	Incremental Period Day YTD Balance Process	18
23.7.4.4	Executing the Incremental Period Day YTD Balance Process	18
23.7.4.5	Verifying the Pipeline	18
23.7.4.6	Snapshot PTD and Incremental PTD Execution Guidelines	19
23.7.4.7	Extract Parameters	19
23.8	OOTB Latest Balances Extract for Management Ledger As Of Date	19
23.9	OOTB Latest Balances Extract for Management Ledger As Of Effective Date	22
23.10	Extraction of Data for Reconciliation Difference	25

## 24 Obtaining Support for Your Service

---

## 25 Key Terms and Concepts

---

25.1	Adjustment Entry	1
25.2	Adjustment Entry Floor	1
25.3	Attributed Dimension	1
25.4	Data set	1
25.5	Dimension	1
25.6	Dimension Attributes	1
25.7	Hierarchy	1
25.8	Global Threshold	2
25.9	Inherit to Child	2
25.10	Reconciliation	2
25.11	Reconciliation Difference	2
25.12	Threshold	2
25.13	Positive Threshold	2
25.14	Negative Threshold	2
25.15	Threshold Breached Type	2
25.16	General Ledger to Product Processor	3
25.17	General Ledger to Product Management Ledger	3
25.18	Consolidation Type	3
25.18.1	Solo	3
25.18.2	Consolidated	3

25.18.3	Inherit to Child	4
25.18.4	Manual Reconciliation Definition	4
25.18.5	GL Level Reconciliation	5
25.18.6	Map Level Reconciliation	5

## 26 Frequently Asked Questions

---

### Index

---

# 1

## Revision History

**Table 1-1 Document Control**

Release and Version Number	Revision Date	Change Log
R26B, V1.0	May 2026	Documented the following: <ul style="list-style-type: none"> <li>• Data File Encryption</li> <li>• Added Balance Year to Date in Local Currency Balance Type for Management Ledger to Product Processor</li> <li>• Catalog Lookup Summary</li> <li>• Singleton Process in PMF</li> <li>• Information Access Control</li> <li>• Revaluation-ML Segments Default Value for Unrealised Gain and Loss Figures</li> <li>• File Watcher</li> </ul>
R26A, V1.0	April 2026	Added information on Accounting Foundation Cloud Service - Standard Edition.
R26.3.1, V1.0	April 2026	Added information on Incremental Extract for Period Day YTD Balance.
R26A, V1.0	February 2026	Documented the following: <ul style="list-style-type: none"> <li>• Updated the number of custom attributes in the <a href="#">Custom Dimension</a> section.</li> <li>• Added <a href="#">Re-registration of Attributes in a Custom SLA</a> section.</li> <li>• Added <a href="#">Catalog Lookup Objects</a> section.</li> <li>• Added <a href="#">Creating Custom User Groups Using IAM Console</a> section.</li> <li>• Added <a href="#">Creating an SLA using New User Interface</a> section.</li> </ul>
R25D, V1.0	November 2025	Documented the following: <ul style="list-style-type: none"> <li>• <a href="#">Use and Execute Custom Reconciliation PMF Process</a></li> <li>• <a href="#">Extraction of Data for Reconciliation Difference</a></li> <li>• Added content on Journal Currency Conversion Level in <a href="#">Journal Ingestion</a> section.</li> </ul>
R25.9.1, V1.0	October 2025	Documented the following: <ul style="list-style-type: none"> <li>• <a href="#">Balance Computation Management Ledger Data Compaction Pipeline</a></li> <li>• <a href="#">Drill Back Capability</a></li> </ul>

Table 1-1 (Cont.) Document Control

Release and Version Number	Revision Date	Change Log
R25C, V1.0	August 2025	Documented the following: <ul style="list-style-type: none"> <li>• <a href="#">Integration with EDMCS.</a></li> </ul>
R25B, V1.0	July 2025	Documented the following: <ul style="list-style-type: none"> <li>• Addition of the widget <a href="#">Missing Master Loader</a></li> <li>• <a href="#">OOTB Latest Balances Extract for Management Ledger As Of Effective Date</a></li> <li>• Addition of a note on Journal intent identifier P and I in <a href="#">Adding a Subledger Application</a> and <a href="#">Ingest Initial Balance</a></li> <li>• Updated the <a href="#">Custom Hierarchies</a> and <a href="#">Revaluation Execution</a> sections.</li> <li>• Added <a href="#">Management Ledger to Policy</a> section.</li> </ul>
R25.3.6	June 2025	Documented the following: Attribute selection from Header or Contracts entities during Header Mapping. See section, <a href="#">Adding a Subledger Application</a>
R25.3.5	May 2025	Updated the details on Multiple Revaluation Rules in the following: <ul style="list-style-type: none"> <li>• <a href="#">Use and Execute the Revaluation Process</a></li> <li>• <a href="#">Use and Execute the Balance Revaluation Retrospective Management Ledger Process</a></li> </ul>
R25.3.3, V1.0	May 2025	Updated the Post Upgrade Steps section.
R25.3.2, V1.0	April 2025	Updated the following: <ul style="list-style-type: none"> <li>• <a href="#">PMF Dashboard for Balance Computation</a></li> </ul>

Table 1-1 (Cont.) Document Control

Release and Version Number	Revision Date	Change Log
R25A, V1.0	April 2025	<p>Documented the following:</p> <ul style="list-style-type: none"> <li>• <a href="#">PMF Error Codes and Descriptions</a></li> <li>• <a href="#">Account Summary Report</a></li> <li>• <a href="#">Transaction Summary Report</a></li> <li>• <a href="#">URL Drill Back from AHCS to AFCS</a></li> <li>• Updated the <a href="#">Creating a Run Pipeline in the New User Interface</a> and <a href="#">Process Monitor for the New User Interface</a> with process code details.</li> <li>• <a href="#">OOTB Latest Balances Extract for Management Ledger As Of Date</a></li> <li>• <a href="#">General Ledger to Policy</a></li> <li>• <a href="#">Use and Execute Balance Revaluation Retrospective Management Ledger Process</a></li> <li>• <a href="#">Revaluation Basis</a></li> </ul>
R24.12.4, V1.0	March 2025	<p>Documented the following:</p> <ul style="list-style-type: none"> <li>• <a href="#">Balance Computation Management Ledger Initialization</a></li> <li>• <a href="#">Use and Execute Balance Computation Management Ledger Initialization Pipeline</a></li> </ul>
R24D, V1.0	January 2025	<p>Documented the following:</p> <ul style="list-style-type: none"> <li>• <a href="#">Access Process Orchestration for New User Interface</a></li> <li>• <a href="#">Designing Pipelines for New User Interface</a></li> <li>• <a href="#">Ledger Sets Report</a></li> <li>• <a href="#">Business Intelligence Publisher</a></li> </ul>
R24.9.4, V1.0	December 2024	<p>Documented the following:</p> <ul style="list-style-type: none"> <li>• Updated the <a href="#">Custom Attributes for OOB Tables</a> section with Ledger, Instrument Contract, Party and Data Source Entities.</li> <li>• Added the <a href="#">PMF Dashboard Error Codes and Descriptions for Balance Computation Engine</a></li> </ul>

**Table 1-1 (Cont.) Document Control**

Release and Version Number	Revision Date	Change Log
R24C, V1.0	October 2024	Documented the following: <ul style="list-style-type: none"> <li>• Support for <a href="#">Modifying a Subledger Attribute</a>.</li> <li>• <a href="#">Data Quality for Data Visualization Reports</a>.</li> <li>• <a href="#">Creating Dataset to View the Custom Attributes in the Data Visualization</a>.</li> <li>• <a href="#">PMF Dashboard for Balance Computation</a>.</li> <li>• <a href="#">PMF Dashboard for Balance Reconciliation</a>.</li> </ul>
R24B, V1.0	July 2024	Documented the following: <ul style="list-style-type: none"> <li>• Support for <a href="#">Beginning of Day Reversal</a> pipeline.</li> <li>• Addition of <a href="#">Revaluation Entries</a> Report.</li> </ul>
R 24A, V 3.0	May 2024	Updated PMF Email Notification topic in the guide.
R 24A, V 2.0	April 2024	Updated Accessing the Accounting Foundation Cloud Service chapter in the guide.
R 24A, V 1.0	April 2024	Documented the following: <ul style="list-style-type: none"> <li>• Support for JSON Web Token Authentication for integrating with ERP. See section, <a href="#">Configure ERP Settings</a>.</li> <li>• Support for user-configuration of email notifications. See section, <a href="#">PMF Email Notification</a>.</li> </ul>
R 24.2.1, V 2.0	February 2024	Added section "Optional Lineage from ERP Cloud FAH to AFCS". See section, <a href="#">#unique_58</a> .

**Table 1-1 (Cont.) Document Control**

Release and Version Number	Revision Date	Change Log
R 24.2.1, V 1.0	February 2024	<p>Documented the following:</p> <ul style="list-style-type: none"><li>• Enhancements to Balance Computation Management Ledger process. See section, <a href="#">Use and Execute the Balance Computation Management Ledger Process</a>.</li><li>• Automated alignment of AFCS revaluation configuration with corresponding revaluation rules in Oracle ERP Cloud. See section, <a href="#">Revaluation</a>.</li><li>• Add custom attributes to all Custom dimensions in the AFCS Reporting area.</li><li>• Balance Computation Engine Reports has been deprecated. See section, <a href="#">Balance Computation Engine</a>.</li></ul>

Table 1-1 (Cont.) Document Control

Release and Version Number	Revision Date	Change Log
R 23.12.1, V 1.0	January 2024	<p>Documented the following:</p> <ul style="list-style-type: none"> <li>• Support for archived data files as input for the Data Ingestion process. See section, <a href="#">Data Tab</a>.</li> <li>• Named extract for YTD balance for each in a period. See section, <a href="#">OOTB Extract for Period Day YTD Balance</a>.</li> <li>• Access control and navigation improvement for Data Visualization and Dashboard users. See section, <a href="#">Accessing the Standard Reports and Dashboards</a>.</li> <li>• Support to Product Processor attributes in the Management Ledger Balance Reports (BCR subject area). See section, <a href="#">Accessing the Standard Reports and Dashboards</a></li> <li>• Ability to view BCE CoA Segments' tree hierarchies. See section, <a href="#">Hierarchy Management</a>.</li> <li>• Enhancements to Reconciliation Difference Report. See section, <a href="#">Dashboard: Home</a>.</li> <li>• Support for the use of new measures for GL-PP Reconciliation. See section, <a href="#">Enable Custom Measures</a>.</li> <li>• Support to select all the ledgers during BCE processing. See section, <a href="#">Use and Execute the Balance Computation Management Ledger Process</a>.</li> <li>• Added seeded hierarchies and its corresponding mapping tables details. See section, <a href="#">Hierarchy Configuration for Reconciliation</a></li> </ul>

**Table 1-1 (Cont.) Document Control**

Release and Version Number	Revision Date	Change Log
R 23.11.1, V 1.0	December 2023	Documented the following: <ul style="list-style-type: none"><li>• Publish Future Dated Events option. See section, <a href="#">Adding a Subledger Application</a></li><li>• Adjustment period details. See section, <a href="#">Accounting Balance Ingestion</a></li><li>• Search improvements. See section, <a href="#">View and Filter PMF Dashboard</a></li><li>• Limitation related to exporting records. See section, <a href="#">Exporting PMF Dashboard Report</a></li><li>• The maximum extracted archive file size details has been added. See section, <a href="#">Adding a Data Extraction</a></li></ul>

# 2

## Get Help

This section describes the Get Help options in the AFCS application.

### 2.1 Access Help Content

Use the Help icon



to access help in the application. If you do not see any help icons on your page, click your avatar or name in the global header and select Show Help Icons.

Note that not all pages have help icons. You can also access the [Oracle Help Center](#) to find guides and videos.

#### 2.1.1 Watch Video



[Watch](#): This video tutorial shows you how to find and use help.

You can also [read about it](#) instead.

#### 2.1.2 Additional Resources

- **Community:** Use [Oracle Cloud Customer Connect](#) to get information from experts at Oracle, the partner community, and other users.
- **Training:** Take courses on Oracle Cloud from [Oracle University](#).

### 2.2 Learn About Accessibility

For information about Oracle's commitment to accessibility, visit the [Oracle Accessibility Program](#). Videos included in this guide are provided as a media alternative for text-based topics also available in this guide.

### 2.3 Get Support

You can get support at [My Oracle Support](#).

For accessible support, visit [Oracle Accessibility Learning and Support](#).

## 2.4 Get Training

Increase your knowledge of Oracle Cloud by taking courses at the [Oracle University](#).

## 2.5 Join Our Community

Use [Cloud Customer Connect](#) to get information from industry experts at Oracle and in the partner community. You can join forums to connect with other customers, post questions, and watch events.

## 2.6 Share Your Feedback

We welcome your feedback about Oracle Applications user assistance. If you need clarification, find an error, or just want to tell us what you found helpful, we'd like to hear from you.

You can email your feedback to [My Oracle Support](#).

Thanks for helping us improve our user assistance!

# 3

## About Accounting Foundation Cloud Service

Accounting Foundation Cloud Service (AFCS) enables you to collate, standardize, quality-assess, repair, enrich, group and publish data from multiple sources for purposes of accounting and financial reporting. AFCS works with Oracle ERP Financials Cloud Accounting Hub and GL to facilitate this. It enables you to choose an optimal chart of accounts in your General Ledger and maintain a separate Management Ledger with additional information grain. The two ledgers will be driven off the same set of journals and therefore be in alignment.

AFCS also facilitates reconciliation between balance figures obtained from core systems against customer-accounts and accounting balance figures in your ledgers. The service's governance facility will oversee all involved processes. Information held in AFCS will be available for analysis, reporting and extraction for external use. You may add your own analytical content to that which is provided with the service.

# 4

## About Accounting Foundation Cloud Service-Standard Edition

Accounting Foundation Standard Edition (AFCS-SE) is a light weight, low cost version of AFCS Enterprise. It enables customers to ingest, standardize source data, apply transformation logic and generating pre accounting attributes. It prepares and structures the data for accounting.

For information on setting up your service, see the [AFCS Getting Started User Guide](#).

The following table depicts the functionalities that are supported in the Standard Edition and Enterprise Edition respectively.

**Table 4-1 Set up and Administration**

Category	Functionality	Supported by Standard Edition	Supported by Enterprise Edition
Domain	Domain selection and deployment	Yes	Yes
Legal Entity	Legal entity setup	Yes	Yes
Fiscal Period	Fiscal period configuration	Yes	Yes
Parameters	Runtime/system parameters	Yes	Yes
ERP Integration	ERP connectivity	Yes	Yes

**Table 4-2 Users and Security**

Category	Functionality	Supported by Standard Edition	Supported by Enterprise Edition
Roles & Groups	Predefined roles	Yes	Yes
Custom User Groups	IAM integration	Yes	Yes
Entitlements	Access control	Yes	Yes

**Table 4-3 Subledger Accounting**

Category	Functionality	Supported by Standard Edition	Supported by Enterprise Edition
SLA Creation	Define SLA	Yes	Yes
Event Types	Configure events	Yes	Yes
Header/Line Mapping	Mapping rules	Yes	Yes
Ledger Assignment	Ledger mapping	Yes	Yes
SLA Pipelines	Execution pipelines	Yes- forward flow only	Yes
Balance Ingestion	GL balance ingestion	No	Yes
Balance Reconciliation	Reconciliation	No	Yes

**Table 4-4 Data Management**

Category	Functionality	Supported by Standard Edition	Supported by Enterprise Edition
File Upload	Data ingestion	Yes	Yes
External Data Descriptor (EDD)	Data definition	Yes	Yes
Connectors	Data transformation	Yes	Yes
Data Quality	DQ rules	Yes- forward flow only	Yes
Data Catalog	Catalog Extensions	Yes	Yes

**Table 4-5 Process Orchestration**

Category	Functionality	Supported by Standard Edition	Supported by Enterprise Edition
Process Modelling	Pipeline design	Yes	Yes
Run Pipelines	Execution engine	Yes	Yes
Parallel Processing	Advanced flows	Yes	Yes
Scheduler	Scheduled runs	Yes	Yes
Monitoring	Process monitor & logs	Yes	Yes

**Table 4-6 Accounting and Processing**

Category	Functionality	Supported by Standard Edition	Supported by Enterprise Edition
Forward Flow	Transaction → Journal → ERP	Yes	Yes

**Table 4-7 Balance Computation**

Category	Functionality	Supported by Standard Edition	Supported by Enterprise Edition
Balance Computation	ML balance calculation	No	Yes
Currency Conversion	Exchange Rate population	No	Yes
Revaluation	FX revaluation	No	Yes
Translation	Multi-currency reporting	No	Yes
Restatement	Backdated processing	No	Yes
Balance Computation PMF	Balance computation pipeline	No	Yes

**Table 4-8 Balance Reconciliation**

Category	Functionality	Supported by Standard Edition	Supported by Enterprise Edition
GL vs PP Reconciliation	Compare GL vs operational data	No	Yes
GL vs ML Reconciliation	Ledger comparison	No	Yes

**Table 4-8 (Cont.) Balance Reconciliation**

Category	Functionality	Supported by Standard Edition	Supported by Enterprise Edition
ML vs PP Reconciliation	Advanced reconciliation	No	Yes
Threshold & Adjustments	Auto/manual adjustments	No	Yes
Reconciliation Rules	Rule engine	No	Yes
Balance Reconciliation PMF	Balance reconciliation pipeline	No	Yes

**Table 4-9 Reporting and Analytics**

Category	Functionality	Supported by Standard Edition	Supported by Enterprise Edition
BCE Dashboards	Balance dashboards	No	Yes
Balance Computation Engine Results	BCE Results	No	Yes
Account Summary	Account Summary	No	Yes
Transaction Summary	Transaction Summary	No	Yes
Reconciliation Framework Analytics	GL/ML/PP reports	No	Yes
Data Visualization	DV	Yes- forward flow only	Yes
Data Quality	DQ rules	Yes- forward flow only	Yes
Business Intelligence Publisher	BI	Yes- forward flow only	Yes
Drill-back (Accounting Journals and Transaction Summary)	Transaction traceability	Yes	Yes

# 5

## Accessing the Accounting Foundation Cloud Service

See the AFCS Get Started [AFCS Get Started](#) guide for information on how to subscribe and set up your cloud account.

# 6

## Post Upgrade Steps

Complete the following post upgrade steps to upgrade the AFCS application to the latest version.

### AFCS 25A

1. Perform a domain deployment after AFCS 25A upgrade is complete.
2. Click **Refresh Metadata** in the **Report Configuration** screen under **Administration**.
3. After upgrade, re-save the **Currency Conversion** screen under **Administration**.
4. The Balance Computation Management Ledger Initialization process must be executed before the execution of other pipelines such as Beginning of Day Management Ledger, Balance Computation Management Ledger and Balance Revaluation Management Ledger. For more information, see [Balance Computation Management Ledger Initialization](#).
5. After upgrade, re-save the **ERP Settings** screen under **Administration**.
6. After upgrade, save the segment in the **Segment Mapping** screen under **Administration**.

### AFCS 25.3.3

- Perform a domain deployment after AFCS 25.3.3 upgrade is complete.

### AFCS 25B

1. Perform a domain deployment after AFCS 25B upgrade is complete.
2. Click **Refresh Metadata** in the **Report Configuration** screen under **Administration**.
3. After upgrade, re-save the **ERP Settings** screen under **Administration**.
4. After upgrade, save the segment in the **Segment Mapping** screen under **Administration**.
5. To ensure that the correct data is selected by the appropriate process, the source data ingestion connectors that load into the Accounting Entries table for the Passthrough SLA and the Day Zero processing must be updated to include the mapping for the Accounting Entry Intent Indicator.
6. All the SLAs in Available or Configured status must be configured again.
7. After upgrade, Revaluation Preparation process must to be executed before executing the Balance Revaluation.

### AFCS 25C

- Post upgrade steps are not required.

### AFCS 25.9.1

1. Perform a domain deployment after AFCS 25.9.1 upgrade is complete.
2. After upgrade, re-save the **Currency Conversion** screen under **Administration**
3. All the SLAs in Available or Configured status must be configured again.

### AFCS 25D

1. Perform a domain deployment after AFCS 25D upgrade is complete.
2. Click **Refresh Metadata** in the **Report Configuration** screen under **Administration**.

3. After upgrade, re-save the **ERP Settings** screen under **Administration**.
4. After upgrade, re-save the segment in the **Segment Mapping** screen under **Administration**.
5. After upgrade, under **Balance Reconciliation**, re-configure the Management Ledger to Policy Type and save it.

 **Note**

This is applicable to Insurance domain only.

#### **AFCS 25.11.1**

- Post upgrade steps are not required.

#### **AFCS 26A**

1. After upgrade, re-save the **Currency Conversion** screen under Administration.
2. Click **Refresh Metadata** in the **Report Configuration** screen under **Administration**.
3. After upgrade, re-save the **ERP Settings** screen under **Administration**.
4. After upgrade, re-save the segment in the **Segment Mapping** screen under **Administration**.

#### **AFCS 26B**

1. Post upgrade, click **Refresh Metadata** in the **Type Configuration** under Balance Reconciliation.
2. Click **Refresh Metadata** in the **Report Configuration** screen under **Administration**.

# 7

## Viewing the System Information

To view the system information, you can do one of two steps:

- In the Home page, under **Frequently Asked Questions**, system details such as **Instance Identifier**, and **Current Patch Version** are displayed.

OR

- In the Home page, click the **My Profile** icon (on the top-right of the page) and click **About**.

# 8

## Setting Up Your Service

This section provides the details on setting up Accounting Foundation Cloud Service (AFCS).

Topics:

- [Domain](#)
- [Legal Entity](#)
- [Fiscal Period](#)
- [Parameters](#)

### 8.1 Domain

Domains represent business segments that you operate. The list of domains available with your service will be listed for you to choose from. Your choice will determine data and metadata artefacts that are deployed by the service for your use. You may choose one or more domains and subsequently revise your choice with additional domains, as needed. You will not, however, be allowed to drop domains once selected and deployed. Please note that additional domains, even when chosen in error, will not adversely affect your usage of the service.

#### 8.1.1 Select your Domain

The domain which is available as part of the catalog is displayed. To select a domain, perform the following steps:

1. In the **Choose Domain** page, select the required domain to deploy from the list of Domains.

If you are logging in for the first time, you can select one or more domains.

2. Click **Continue**.

A confirmation message is displayed.

3. Click **Yes** to proceed or click **No** in case you wish to revert. If you have selected **Yes**, the deployment process for the selected domain begins.

The status of the deployment is displayed.

#### 8.1.2 Add Domain

Use the Add Domain feature if you have already deployed one or multiple domains and subsequently want to add more domain(s). Beginning with the 23C release, in addition to the existing Banking domain, AFCS supports addition of the following domains:

- Life Insurance
- Annuity
- Retirement
- General insurance (Property and Casualty)
- Health insurance

- Reinsurance Issued

To add a new domain:

1. From the **AFCS Home** page, click the **My Profile** icon and click **Administration**.
2. Click **Add Domain** from the LHS menu. The available domains are displayed.
3. Select the domain(s) you want to deploy and click **Continue**. A confirmation message is displayed.
4. Click **Yes** to proceed and then click **Deploy**. The deployment process for the selected domain(s) begins. All logged in users are displayed a message stating that a new domain is being added. Until the completion of this task, no logged-in user is permitted to make any change using the AFCS UI. The status of the deployment steps is displayed.
5. After the deployment is completed, click **OK** to continue UI operations.

### 8.1.3 Deploy the Domain

On the **Deploy Domain** page, the selected domains are deployed, and the status of the deployment is displayed.

Click **Deploy** to initiate application configuration to view the following and their status:

- **Deploy Catalog**  
This step deploys a physical instance of data structures according to the Domains chosen.
- **Deploy Dimension Rules**  
This step deploys Dimensions used by the service, including those designated Slowly Changing Dimensions.
- **Generate Data Connections**  
This step deploys Data Services required to facilitate movement of data within the deployed data structures.
- **Generate Data Quality Checks**  
This step generates and deploys Data Quality assessment routines based on specification in the Data Catalog.
- **Applying Redaction Policy**  
This step applies required data protection via redaction instruction to portions of the Catalog that have been marked sensitive, including Personally Identifiable Information (PII).
- **Refresh Data Interfaces**  
This step generates and deploys the logical abstraction layer to facilitate Data Services based on specifications in the Catalog.
- **Deploy Subledger Applications**  
This step generates and deploys definitions of Subledger Applications packaged by the service out-of-the-box. The set of SLAs thus deployed will be based on the Catalog structures deployed, which in turn is decided by user-choice of Domains in an earlier step.
- **COA ML Extensions**  
This steps will perform COA ML segment extensions for any new entities which are qualified for COA ML segment extension.
- **Generate Pipelines**  
This step generates and deploys definitions in the service's Process Management Framework for sequences of tasks that are required to carry out functional outcomes of the service.

The deployment steps are marked with a success or failure icon. Only when all the deployment steps are successful, you can click **Continue** to proceed.

## 8.2 Legal Entity

This step allows you to define one or more Legal Entities for which the service maintains the Management Ledger and perform related functional tasks. For a Legal Entity, a Management Ledger is maintained and is required to provide such information by way of financial reports as a reporting entity. The service supports preparation and maintenance of a hierarchy of Legal Entities, based on which the following information may be captured.

Topic:

- [Legal Entity Settings](#)

### Note

Maximum levels supported for Legal Entity hierarchy in Balance reconciliation is 5.

### 8.2.1 Legal Entity Settings

Use the Legal Entity Settings to set up the Reporting Currency.

To set up the Reporting Currency, follow these steps:

1. To navigate to Legal Entity Settings, on the Home page, click **Administration**, and click **Legal Entity**. The **Legal Entity Settings** page is displayed.
2. On the **Legal Entity** page, all available Legal Entities are listed on the left hand side. To set up the Reporting Currency and the Fiscal Year for a Legal Entity, select the required Legal Entity, and do the following:
  - Set the fiscal period to open for posting entries by disabling or closed for posting entries by enabling the **Locked?** option. An open posting period is when the selected posting period is set to open and the other posting periods stay closed.
  - Set the **Reporting Currency** to the required standard. This Reporting Currency is used during the Execution Process in Process Orchestration.

### Note

Once a new Legal Entity is available, users must select the new Legal entity and select the required Fiscal year in the Legal Entity Settings screen and click **Save**. This action must to be performed whenever a new Legal Entity is added and selected for the required Fiscal year.

3. Click **Save** to save the Legal Entity settings.

## 8.3 Fiscal Period

Use this setup to configure the Fiscal Period for a specific Legal Entity or to compile Fiscal Periods.

Topics:

- [Set Up Fiscal Periods](#)

- [Compile Fiscal Periods](#)

## 8.3.1 Set Up Fiscal Periods

You can add or edit a Fiscal Period.

To add or edit a Fiscal Period, perform the following steps:

1. During deployment, a user with Administrator Privileges can set up Fiscal Periods using this procedure, or, after deployment, the Administrator can manage Fiscal Periods by navigating to the Fiscal Period settings. To navigate to the Fiscal Period settings, on the Home page, click **Administration**, and click **Fiscal Period**.

The Fiscal Period Settings page is displayed. During deployment, the user with the Administrator privileges can set up Fiscal Periods using the same procedure.

2. On the **Setup** tab, there are four built-in Fiscal Year Quarters. They are **Quarter 1**, **Quarter 2**, **Quarter 3**, and **Quarter 4**. Select the required quarter for a specific Entity and then proceed to add or edit a Fiscal Period.
3. To create a new Fiscal Period, perform the following steps:
  - a. Click **Add Fiscal Period**. A new row is added to the Fiscal Periods list with a new **Fiscal Period Name** and other details. To edit the **Fiscal Period Name**, double-click the Fiscal Period Name Value and do the changes.
  - b. To select the starting month for the Fiscal Period, double-click the **Start Month Value** and select the required value in the list. By default, this field displays January.
  - c. To select the starting day of the selected **Fiscal Period Start Month**, double-click the **Start Day Value** and select the required value in the list.
  - d. Similarly, select the values for **End Month** and **End Day** for the selected Fiscal Period. You need to verify these values for all quarters.
4. To edit an existing Fiscal Period, double-click the values of the **Fiscal Period Name**, **Quarter Name**, **Start Month**, **Start Day**, **End Month**, **End Day**, and then do the changes.
5. Click **Save**.
6. To delete an existing Fiscal Period, click the corresponding **Delete** option. A confirmation message is displayed. Acknowledge the message.

### ① Note

Along with the Fiscal Period Entity, the Date Entity will also be populated with the same set of records.

### ① Note

The Fiscal Periods set up in this Fiscal Period Module are associated with the Legal Entity. This Fiscal Period Attribute is sourced as a part of the Legal Entity.

**Note**

User needs to configure fiscal periods by keeping Day0 load under consideration. E.g. If Day 0 is 10 May 2023, fiscal calendar should logically cover FY 2023 and perhaps FY2024. This should be sufficient to run Balance Computation tasks.

## 8.3.2 Compile Fiscal Periods

To assign a year or a fiscal year to the fiscal periods of the legal entity, use the **Compile Fiscal Periods** process.

To compile a set of fiscal periods for a year, perform the following steps:

1. During deployment, the user with administrator privileges can set up **Compile Fiscal Periods** using this procedure, or, after deployment, the administrator can compile the fiscal periods by navigating to the **Fiscal Period Settings**. To navigate to **Fiscal Period Settings**, on the Home page, click **Administration**, and click **Fiscal Period**. The **Fiscal Period Settings** page is displayed. Select the **Compile** tab. During deployment, a user with Administrator privileges can set up Fiscal Periods using the same procedure.
2. On the **Compile** tab, click **Start Date** and select the required value. Then click **End Date** and select the required value.

Recompilation of a start date cannot perform data load for earlier dates than the start date which has already been compiled. In this scenario, a data ingestion service fails with an error as the partitions cannot be created for earlier dates.

3. Click **Compile**.

A date dimension and calendar of fiscal periods for the legal entity for the selected date range is generated.

## 8.4 Configure Parameters

The Parameters are constant-value, run-time, or current-date variables intended for use with AFCS. Apart from a seeded set of System Parameters, you can add, modify, or remove them as needed.

### 8.4.1 Accessing Parameters

To access the Parameters window, follow these steps.

1. On the Home page, click the **My Profile** icon located on the top-right corner and click **Administration**. Select **Parameters** from LHS (left hand side menu). The Parameters Summary window is displayed.
2. Use the search option to search for a specific source.
3. Click **Add** to create a parameter. For more information, see [Defining a Parameter](#) section.

### 8.4.2 Parameter Settings

This section describes parameter settings.

**Table 8-1 Fields in the Parameters Window**

Fields	Description
Parameter Name	The name for the placeholder that you want to define. For example, MISDATE, which can be used as a placeholder for Date.
Parameter Description	The description for the parameter you want to define. Example description: "MISDATE can be used to substitute the date values for each day, dynamically, in mmddyyyy format."
Parameter Type	There are three parameter data types: <ul style="list-style-type: none"> <li>• <b>Constant</b> is selected for substituting a constant value.</li> <li>• <b>RunTime</b> is selected for substituting a value, dynamically, in run time. In the example that is used here, MISDATE can be selected as Run Time because it is used to make a substitution dynamically.</li> <li>• <b>CurrDate</b> is selected for substituting a value as Current System Date.</li> </ul>
Value	Applicable only for <b>Constant</b> data types. Holds the actual value of the parameter.

### 8.4.3 Defining a Parameter

To define a new Parameter, follow these steps:

1. Click **Add** on the **Parameters Summary** screen.
2. Specify the information as described in the Parameter Settings section. [Parameters Window](#).
3. Click **Save**.

### 8.4.4 Modifying and Viewing a Parameter

You can edit or view an existing parameter.

To edit or view a parameter, follow these steps:

1. Click the required parameter from the **Parameters Summary** screen.
2. Modify the name, description, type, value, default value or date format.
3. Click **Save**.

### 8.4.5 Deleting a Parameter

To delete an existing parameter, follow these steps:

1. On the **Parameters Summary**, click **Delete** corresponding to the parameter you want to delete.  
Confirm your action.
2. Click **Yes** to delete the Parameter.

**Note**

You can not delete parameters in the following cases:

- If the parameter is used by any higher object. Example: Connector/EDD.
- If the parameter is pre-seeded.

## 8.4.6 Dependency

Clicking **Dependency** lists where the entire parent Parameter has a dependency.

# 9

## Managing Users and Entitlements

Before the service can be used to configure business functions and execute the ensuing processes, you must define users, configure their access rights and define their entitlements and privileges. This ensures that authentication, security, and access control are imposed on the service and the data it processes.

For information on how to manage users and user privileges in AFCS, see the [Administer and Secure Your Service User Guide](#).

### Note

In AFCS Standard Edition, backward flow is not available to users and any user privileges or entitlements related to backward flow are not applicable here. For more information, see the [About Accounting Foundation Cloud Service- Standard Edition](#).

# 10

## Creating Custom User Groups Using IAM Console

This feature allows users to create a custom user group in Identity and Access Management (IAM) console, map it to a user and post the login into the application, the user groups are synchronized in the AFCS application. Users can also map the relevant roles to custom user groups in the application.

### Note

User role creation is not supported in the application.

### Note

User Groups must only be created in the IAM console to be synchronized in the AFCS application.

### Note

DIS roles cannot be mapped directly to any custom group. If a DIS functionality is required, then the corresponding DIS group (Ex: AFCS-BIConsumer, AFCS-BIContentAuthor, AFCS-BIAdministrator, AFCS-DVConsumer, AFCS-DVContentAuthor, AFCSPIVWGRP, AFCSFINHEAD, AFCSFINANALYST and AFCSFINACCOUNTANT ) must be mapped to the user, in addition to any relevant custom groups.

User groups must be created based on the roles mentioned in the table below:

**Table 10-1 Users Roles and Description**

Role Code	User Role Name	Description
GRP_READ, USR_READ,FUNC_READ, ROLE_READ, ACCINTVW, CATLGVW	Group Read Role, User Read Role, Function Read Role, Role Read Role, Accounting Integration View and Data Catalogue View	Mandatory roles needed to login to AFCS and view the home page.
ACCINTANLST	Accounting Integration Business Tasks	Additional role needed to Create, Delete, Edit and publish SLAs.
CATLGANLST	Data Catalogue Business Tasks	Additional role needed to Log an issue to Data Catalog.
DIVIEW	Data Integration View	Additional role needed to view Data Ingestion and Data Extraction link in LHS.

**Table 10-1 (Cont.) Users Roles and Description**

Role Code	User Role Name	Description
DIANLST	Data Integration Business Tasks	Additional role needed to Create, Save and Delete DI objects (Data Extraction and Data Ingestion).
RECONVIEW	Reconciliation View	Additional role needed to view Balance Reconciliation. <b>NOTE:</b> In the AFCS Standard Edition, backward flow is not applicable and therefore Balance Computation and Balance Reconciliation are not supported.
RECONANLST	Reconciliation Business Tasks	Additional role needed to View and Edit Balance Reconciliation. <b>NOTE:</b> In the AFCS Standard Edition, backward flow is not applicable and therefore Balance Computation and Balance Reconciliation are not supported.

**Note**

For more information on User Roles and their description, see [User Roles and Descriptions](#).

To create a custom user group, follow these steps:

1. Login into the IAM console.
2. Navigate to the domain and select User Management in the User Interface.
3. Under **Groups** section, click **Create group** button and the Create group details page is displayed.
4. Enter the Group name and Description.

**Note**

Group Name can only have underscore "\_" as a special character and other special characters are not supported from AFCS.

5. Enable the toggle for **Users can request access** to request access to the group.
6. Under **Users** section, search for the user you wish to assign this group to, select the user and click **Create**. The group is now created and assigned to the corresponding user.
7. From the Group section, search for AFCS Administrator Group, Identity Administrator Group and Identity Authorizer Group and click **Assign user to Group** button.

**Note**

It is mandatory to assign users to AFCS Administrator Group and Identity Administrator Group or Identity Authorizer Group to access **Admin Console User Interface** in the AFCS application.

## 10.1 Accessing Admin Console User Interface

To access the Admin Console UI, follow these steps:

1. Login to the AFCS application using the user credentials to which the created custom user group has been assigned to.
2. Go to **My Profile**, under **Administration**, select **Admin Console** tab.
3. Click **Identity Management** tile and select **Groups** tab at the bottom of the page.
4. From the Groups Summary page, search for the custom group that has been created in the IAM console and click on the corresponding user group.
5. From the Group details page, navigate to the **Mapped Roles** tab.
6. Click **New Mapping** button and all the available roles to be mapped are displayed.
7. Select all the mandatory roles and click **Map** button. A confirmation message is displayed after successful mapping. The mapping will be completed after authorization.
8. Enable Authorization view and the authorization button is enabled.

**Note**

Users who are mapped to AFCS Administrator Group and Identity Authorizer Group can only approve or reject the mapping request.

9. After mapping a user group, ensure to authorize it accordingly. In Mapped Groups, select the user-user group mapping that requires authorization. Click **Authorize** to approve or **Reject** cancel the mapping request.

# 11

## Connecting to your Oracle ERP Service

For your service to carry out its business functions, it is necessary for it to communicate and exchange data with your Oracle ERP Financials Accounting Hub Cloud Service instance. This section describes the steps you need to take to facilitate this.

### 11.1 AHCS Instance Details

Topic:

- [Configure ERP Settings](#)

#### 11.1.1 Configure ERP Settings

Configure ERP Settings to establish the connection between AFCS and other applications and other changes post-deployment.

##### Note

**For Service Instances Upgrade:** ERP Settings should be re-saved via the UI for automatic creation of BI Cloud Connector extract jobs to be available.

##### Note

The user credentials to access the ERP interface should have the following entitlements at a minimum:

- Access and execute upload of files into UCM associated with said ERP Financials service instance.
- Access and execute APIs in said ERP Financials service instance.

##### Note

**Users must raise a SR for allow listing the following URLs:**

- **ERP URLs :**  
The example URLs are as follows:
  - `https://xxx.login.xx.oraclecloud.com`
  - `https://xxx.fa.xx.oraclecloud.com`
- **AFCS URL :**  
The example URLs are as follows:
  - `https://xx-xxxxx.ofsaa.xx-xxxxx-1.ocs.oraclecloud.com/<<tenant-id>>/afc`

To configure ERP Settings, follow these steps:

1. On the Home page, click the **My Profile** icon located on the top-right corner and select **Administration**.
2. Select **ERP Settings** from the LHS menu.
3. Enter the following details:
  - **URL for Accounting Hub Cloud Service:** Enter the URL assigned to you as part of your Oracle ERP Cloud AHCS subscription here. This information is specific to your tenancy on Oracle Cloud and subscription to ERP Cloud AHCS instance.  
For example:  
`https://abc.de.fg.oraclecloud.com`
  - **Version:** Enter the version of the AHCS instance.
  - **User ID:** Enter the user identification assigned to you for the AHCS instance here.
  - **Password:** Enter the password for your AHCS instance here.  
OR  
You can specify the JWT token-based authentication to integrate with ERP.
  - **Token:** Enter the JWT token. For more details on how to generate the JWT token, see [Configure JWT Authentication Provider](#).
  - **Event Type Column Name:** This is pre-populated with the Transaction Type value: the auto-generated value for the **Transaction Type Column Name** in the Register Transaction Source System step.  
If you modify the auto-generated value for **Transaction Type Column Name** in the Register Transaction Source System step, edit the pre-populated text and capture the assigned column name here.
  - **Line Number Column Name:** This is pre-populated with the LINE NUMBER value, the auto-generated value for **Line Number Column Name** in the Register Transaction Source System step.  
If you modify the auto-generated value for the **Line Number Column Name** in the Register Transaction Source System step, edit the pre-populated text and capture the assigned column name here.
  - **Date Format:** Enter the date format which your instance of AHCS accepts for the date columns. If you do not enter a value here, the date field uses the default format.
  - **Supporting Reference Mapping:**  
Line numbers generated for each SLA in AFCS must be configured as supporting reference attribute in ERP. The supporting reference attribute must be added to all accounting methods. Once completed, respective supporting reference attribute number must be specified in AFCS by updating the **Supporting reference mapping** field. By default, it is set to **Supporting Reference 31**.  
  
For more details on how to add a line number as a Supporting Reference in an ERP instance, refer to the ERP documentation.
4. Click **Save** or **Test Connection**.

For more information, see the [Verification of ERP Setting](#) section.  
After you save, the entered settings are used while producing the Transaction Template. This is a one-time setup activity. Do not change these settings unless required by changes to your instance of AHCS.

After you save, the following jobs are created in the BI Cloud Console for General Ledger and Journal Extraction:

  - GL\_SR\_EXTRACT\_JOB

- JOURNAL\_INGESTION\_EXTRACT\_JOB

**Note**

"Oracle Financials Cloud BICC (Business Intelligence Cloud Connector) 'prune time' is a setting that specifies how long before the last extract to extract data from, with the default being 1,440 minutes (24 hours). This value can be adjusted in Extract Preferences for each offering. A shorter prune time is recommended for more frequent extracts to prevent data overlap, while a setting of zero eliminates overlap entirely. Please refer [Creating a Business Intelligence Cloud Extract](#) for details. In the context of extracts via BICC for use in AFCS, prune time should be set to 0 such that generated incremental extracts have no overlaps."

## 11.2 Verification of ERP Settings

Use the **Test Connection** option on the ERP Settings window to check the established ERP connection.

To perform changes post-deployment, see [Configure ERP Settings](#).

# 12

## Configuring Accounting Content

This section provides information about configuring the Subledger Application.

### Related Topics:

- [Subledger Applications](#)
- [How to Register an SLA](#)
- [Event and Journal Grouping](#)

### 12.1 Sub Ledger Application Definition

Oracle ERP Financials Accounting Hub and General Ledger reflect the traditional segregation between the general ledger and associated subledgers. Detailed transactional information is captured in the sub ledgers and periodically imported and posted in summary or detail to the ledger. Your service aligns with this and allows you to define Subledger Applications (SLAs) aligned with contract and transaction types associated with financial instruments you process.

After the service set up is complete, the **Sub Ledger Applications** page is displayed. The service provides a set of pre-configured SLAs, aligned with contract and transaction types related to the domains you chose. You can define your own SLAs.

The **Sub Ledger Applications** page displays user name, last log in details and open tasks, if any.

#### 12.1.1 Subledger Application Summary

##### Note

In the AFCS Standard Edition, backward flow is not applicable and therefore Balance Ingestion and Balance Reconciliation are not supported. For more information, see the [About Accounting Foundation Cloud Service- Standard Edition](#)

To navigate to the Sub Ledger Application summary and understand the details provided there, follow these steps:

1. From the Oracle Financial Services Accounting Foundation Cloud page, select **Sub Ledger Applications**. The **Sub Ledger Application** window is displayed.

Figure 12-1 Subledger Application

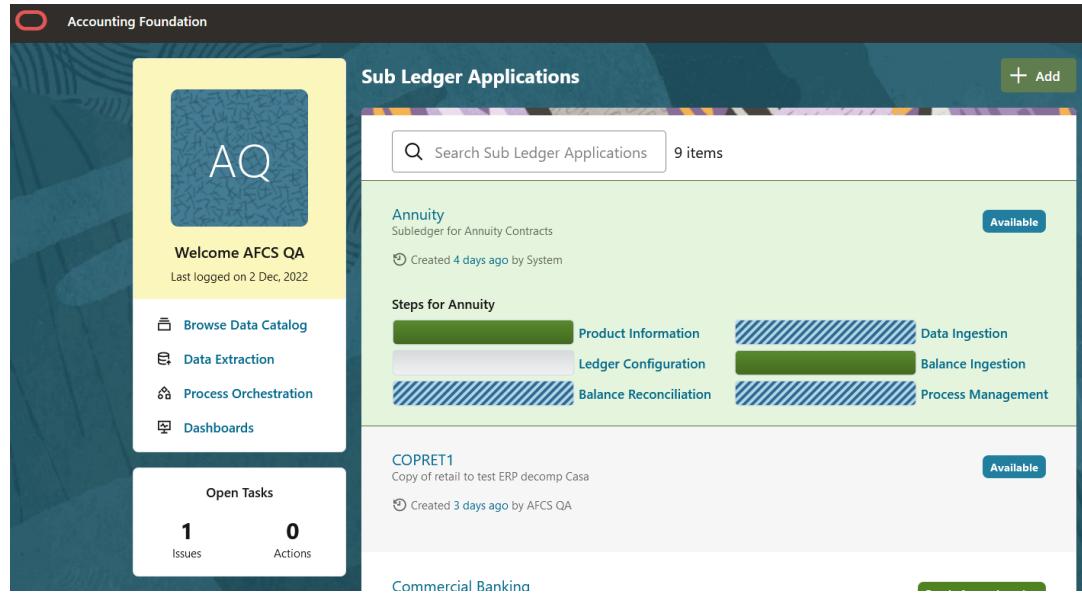

2. You can search for a subledger name or a subledger short name. A list of pre-packaged subledgers appears. For more information, see the [Pre-packaged Subledgers](#) section.

#### Note

You can not edit pre-packaged subledgers using the **Sub Ledger Application** screen.

3. In the **Sub Ledger Application** page, you can view the status of the SLA, which can be in one of the following statuses:
  - a. Draft
  - b. Ready for Registration
  - c. Registered
  - d. Configured
  - e. Available
4. Click a subledger application name to view the steps and the status of the subledger application. The steps of the SLA are as follows:
  - a. **Product Information:** For details, see the Subledger Applications section.
  - b. **Data Ingestion:** For details, see the External Data Descriptors and Connectors section.

#### Note

Click the **Data Ingestion** link and then click the **Click here** link to download data specifications or entities that must be loaded before executing any SLA. Clicking the link will download a file displaying all the tables. You can download this data only for **Configured** or **Available SLAs**. An error message is displayed if you click on an SLA in the **Ready for registration** state.

- c. **Ledger Configuration:** For details, see the Ledger Configuration section.
  - d. **Balance Ingestion:** For details, see the Connectors section.
  - e. **Balance Reconciliation:** For details, see the Reconciliation section.
  - f. **Process Management:** For details, see the PMF section.
- Hover on each step to know its percentage completion status.
5. On the **Sub Ledger Application** page, click **Add** to create a new subledger. For more information, see the [Adding a Subledger section](#).
  6. See [Register an SLA section](#) for more details on registering subledger applications configured in this application.

## 12.1.2 Pre-packaged Subledgers

**Table 12-1 List of Seeded Subledgers**

Subledger Application	Contract Types
Annuity	Annuity Contracts
Commercial Banking	Correspondent Accounts
	Swaps Contracts
	Loan Contracts
	Merchant Cards
	Term Deposit Contracts
	Casa
	Bill Contracts
	Over Draft Accounts
	Commitment Contracts
	Leases Contracts
	Cards
	Letter Of Credit Contracts
	Swaps Contracts
	Credit Derivatives
Foreign Exchange Contracts	
Option Contracts	
Futures Contracts	
Investments	
Repo Contracts	
Islamic Banking	Ijarah Accounts
	Istisna Accounts
	Mudabah Accounts
	Murabahah Accounts
	Musharkah Accounts
	Salam Accounts
	Sukuk Accounts
	Accounting Entries
Passthrough	Accounting Entries
Policy Loan	Loan Contracts
Retail Banking	Loan Contracts
	Term Deposit Contracts
	Casa

**Table 12-1 (Cont.) List of Seeded Subledgers**

Subledger Application	Contract Types
Treasury	Annuity Contracts
	Over Draft Accounts
	Cards
	Correspondent Accounts
	Swaps Contracts
	Credit Derivatives
	Foreign Exchange Contracts
	Option Contracts
	Futures Contracts
	Borrowings
	Investments
	Commitment Contracts
	Repo Contracts
Life Insurance	Life Insurance Contracts
Property and Casualty	Property And Casualty Contracts
Health Insurance	Health Insurance Contracts
Retirement	Retirement Accounts
Reinsurance Issued	Reinsurance Contracts Issued
Reinsurance Held	Reinsurance Contracts Held

## 12.2 Adding a Subledger Application

This section describes how to add a Subledger Application (SLA). To add an SLA, complete the following steps:

1. Click **Add**.
2. Provide the following **Details** information:
  - Specify a unique Subledger Application Name.
  - Describe the Subledger Application.
  - Specify a unique code for Subledger Application.
  - Select the Event Class as **Transaction** or **Passthrough**. Based on the selected **Event Class**, the **Products** or **Entity** list is updated.

### Note

Users must mark the Journal intent data in the Stage Accounting Entries as **P** for the SLA process to be executed.

- Select the **Products or Entity**
- The **Publish Future Dated Events** option specifies if future-dated journals (where header event date corresponding to accounting date in FAH/GL is greater than as-of date) will be published or not. By default, this option is enabled. If this option is disabled, AFCS will only publish non-future-dated journals from what has been sourced.

**Note**

It is recommended to not modify this option after it is set. If there is a business-case to change this, raise a service request on [My Oracle Support](#).

- By default **Yes** is selected to group the events. Select **No** to post the line records as is without journal grouping.
  - Click **Next**.  
Acknowledge the confirmation message. The SLA details are successfully saved.  
The status of the subledger changes to **Draft** and **Created By** details are added.
3. Provide the following **Event Types** details:
- From the list of event types available, select the required event type or use the search box to search for an event type.
  - Click **Add Event Type** to add your own event type and provide the following details.
    - **Name**
    - **Code**
    - **Description**
    - **Event Class**
  - Click **Save**. A new event type is added to the list of Event Types.
  - Click **Next**.

**Note**

You can add or modify the Event Type for an SLA even after it is registered or in configured status. In case of modification or addition, the same has to be performed in the ERP as well.

**Note**

If an Event Type is added or modified after SLA is registered/configured and if the same Event Type is not present in the ERP, SLA execution fails. To proceed further, you need to add or modify the same Event Type in the ERP and re-run the SLA.

4. Provide the following **Attributes** details:
- a. From the list of attributes available in the application, select the required attribute use the search box to search for an attribute.
  - b. Click **Add Attribute** to add your own attribute and provide the following details:
  - c. Enter the following details:
    - Name
    - Physical Name
    - Domain
  - d. Select the **Attribute Type**. You have **Header** and **Line** as options.

- e. Select the **Event Class**. You have **Passthrough** and **Transaction** as options.
- f. Click **Save**. A new attribute is added to the list of Attributes.
- g. Click **Next** .

**Note**

Before proceeding with Header Mapping, you must register the SLA. For more information, see the [Registering Accounting Content with your ERP Service section](#).

5. Provide the following **Header Mapping** details:
  - a. Select the required **Data Mapping** from the left menu.
  - b. Enter the **Header Data Mapping Name** in **Specify the Header Data Mapping Name** field. This is auto-populated. You can change it as required.
  - c. Define the mapping from the list of subledger attributes and account attributes using the corresponding check boxes. Only selected subledger attributes will be used.
  - d. From the **Account Attributes** drop down, search for the attribute that you wish to add or modify, the search result is displayed. Select the corresponding attribute either from the **Header** entity or from the **Contracts** entities list.

**Note**

Points to consider during entity attribute selection:

- AFCS will now permit explicit choice of whether header attributes are picked from header entity or contracts entities.
- This only applies to attributes that are currently present as standard in the header entity.
- This provision is not to afford users the option of leaving contract-grain attributes unchanged; it only seeks to remove the requirement to have such change registered in advance of SLA data publishing.
- All other activities where contract information or any attribute at that grain is relevant, including Balance Reconciliation, will remain unchanged.
- Wherever contract-grain attributes are required, they will continue to be read from contract entities.

**Note**

You must use a Header ID which is unique only within a Business or an As-of-date for Subledger applications.

- e. Click **Next** .

**Note**

Here, you can see the list of product tables and the respective columns. Ensure that the data selected in the product and transaction tables is available in the staging tables too.

6. Provide the following **Line Mapping** details:
  - a. Select the required **Data Mapping** from the left menu. Here, you can see the list of transaction tables and the respective columns. Ensure that the data selected in the product and transaction tables is available in the staging tables too.
  - b. Specify the header data mapping name in **Specify the line data mapping name** field. This is auto-populated. You can change it as required.
  - c. Define the mapping from the list of subledger attributes and account attributes using the corresponding check boxes. Only selected subledger attributes will be used.
7. Click **Next**.

In **Ledger Name Assignment**, select the ledgers relevant to the Sub Ledger Application and the assignment attributes to perform ledger name assignment. Also, select the **Default Ledger** for the SLA. The ledger names are fetched from ERP. Each SLA can now have multiple ledger names configured based on the attributes.

**Note**

Only the Text related header attributes are displayed for selection.

For more information, see the [Configuring a SLA section](#).

8. Click **Next**.

Under **Review**, you can view the details of the SLAs. The **Review** tab, also displays the details of the connectors defined for the current SLA.
9. Click **Publish**.

The SLAs which have connectors are auto generated. You cannot modify seeded connectors.
10. Click **Yes** to acknowledge the conformation message.

A pipeline is automatically created for the SLA in Process Management. Execute the pipeline using the **As of Date** parameter.

For more details, see the [Executing the SLA Pipelines section](#).
11. Click **Yes** to continue.

A confirmation message is displayed after the SLA is published. The status of the SLA changes to **Available**.

To unpublish an SLA, see [Unpublishing SLAs](#).
12. Click the SLA; navigate to **Product Information > Review** to view the SLA connectors.

For more details, see the [Creating Connectors](#) section.

## 12.3 Event and Journal Grouping

### Note

This is the part of the SLA Header and Line Mapping sections.

Event or Transaction types refer to accounting events that are captured when transactions are committed or processed. While creating a subledger, different transaction types are created so that all the transactions can be classified into one or the other event type and are used for creating journal lines. Examples of transaction types can be withdrawal, deposits, servicing, fees, charges, and so on.

Transaction types are required to collect the transaction data and process it into accounting data necessary to form the subledger information. Data from different source systems come together and are processed depending on these categories to form ledger information.

### Note

To use pre-packaged SLAs, you must standardize transaction types to those defined in the SLA before processing.

The **Subledger Event Grouping** functionality is introduced to the group data, based on a few seeded dimensions while extracting and then posting them to AHC. Grouping is based on dimensions and significance. Similarly, while loading the data from AHC to STG\_GL\_DATA, aggregation based on the dimensions and the basic primary key columns of the GL data table help in maintaining the uniqueness of the table without any errors.

Grouping functionality includes combining data based on some preseeded columns in both header and line-level data. When data is grouped on some dimensions and transaction numbers are not considered for grouping, there is a requirement to regenerate the transaction numbers. As aggregate columns are different in header and line level, aggregation happens separately for header and line data. However, the only connection between the line and header data is the transaction number. Therefore, to maintain the connection, pair up the corresponding header and line connectors along with a mapping table, which maintains actual transaction numbers with a map to newly generated or replaced transaction numbers.

Header data is grouped based on the attributes selected during header mapping. Line data is grouped only if grouping is enabled, and based on the attributes selected during line mapping

## 12.4 Subledger Attributes

The Subledger Attributes user interface provides a list of seeded Header and Line attributes, which can be mapped to an SLA while defining it. You can also add multiple attributes to the list of attributes, which can be mapped to an SLA during SLA configuration. The ledger balances can be calculated based on these subledger attributes. To accommodate custom attributes, there is an option to add custom attributes that can vary from user to user to configure a custom subledger. These custom attributes can help in creating rules and extracting ledger balances in a required way.

## 12.4.1 Adding a Subledger Attribute

To add a subledger attribute, complete the following steps:

1. From the **Subledger Application** window, select **Subledger Attributes**. The **Subledger Attributes** window is displayed with a list of seeded data with logical and physical names.
2. Click **Add** to add a new attribute.  
The **Add Attribute** window is displayed.
3. Enter the **Name** and **Physical Name**.  
**Physical Name** can have only numbers and alphabets in upper case.
4. Select the **Domain**, **ui**, and **Transaction/Passthrough** details.  
You can select **Transaction** or **Passthrough** as the type of subledger.
5. If the new attribute added is a Header Type, it appears in **Transaction Information**. If the new attribute added is a Line Type, it appears in **Line Information** in the SLA.
6. Click **Save**.

### Note

You can delete a new attribute that has been added but not a seeded attribute. An existing custom attribute which is not linked to any SLA can be deleted. If the added attribute is already mapped in the SLA and saved, it cannot be deleted.

## 12.4.2 Modifying a Subledger Attribute

A custom Subledger attribute can be modified before it is mapped to any SLA or if it is mapped to an SLA which is in **Draft** or **Ready for Registration** statuses.

To modify a custom subledger attribute, complete the following steps:

1. From the SLA Home page, select the SLA which is in **Draft** or **Ready for Registration** status.
2. Navigate to the product details tab.  
The Subledger application details page is displayed.
3. Navigate to the **Attributes** in the SLA details.  
The list of available attributes are displayed.
4. Select the custom attribute which needs modification.  
The Attribute details window is displayed.
5. Modify the required details and click **Save**. The modification can be done as per the below matrix.

### Note

When the custom attribute is already mapped to other SLAs in **Draft** or **Ready for Registration** status, then the already selected options under **Attribute Type** and **Event Class** fields cannot be unchecked, but the other available fields of **Name**, **Physical Name** and **Domain** can be modified.

**Note**

Before the custom attribute modification, you can deselect the custom attribute from all the SLAs where they are mapped (Draft or Ready for Registration only), post which all the five fields **Name**, **Physical Name**, **Domain**, **Transaction Type** and **Event Class** can be modified.

### 12.4.2.1 Re-registration of Attributes in a Custom SLA

Users can now re-register attributes only for a custom SLA which is in a **Registered** or a **Configured** status using the **Re-register** option in the AFCS application.

To re-register attributes in a custom SLA, follow these steps:

1. Download the data template generated by AHCS consisting of the attributes that are to be added in AFCS application.
2. Login into AFCS application.
3. On the Home page, from the list of Subledger applications, select the corresponding SLA that you wish to re-register and click the **Product Information** link.
4. On the Product Information page, navigate to **Attributes** section and from **Actions** drop down, click **Re-register** and select the data template.

**Note**

This option of re-registration of a custom SLA is enabled to synchronize the data between ERP Financials Cloud and the AFCS applications respectively.

**Note**

If an SLA attribute from ERP is not available in AFCS, then create an attribute using **Add Attribute** option in AFCS and then **Re-register**.

# 13

## Registering Accounting Content with your ERP Service

### ① Note

#### For Service Instances Upgrade:

Existing SLAs in the **Available** status must be re-published (UnPublish, Re-configure, and Publish) to ensure that the process is up to date.

### 13.1 Registration of SLAs with Accounting Hub Service

#### Topics:

- [Registration of SLAs](#)

### ① Note

Before registering the Account Content with ERP Service, you must configure details in **Details**, **Event Types**, and **Attribute** tabs. For more information, see the [Adding a Subledger Application](#) section.

**Figure 13-1 Periodic Operational Activities**



To register the SLAs with Accounting Hub Service, complete the following steps:

### ① Note

At least one subledger header attribute of any type (i.e. Domain) and a subledger line attribute of Text, Date and Number type (i.e. Domain) must be selected in the Attributes screen apart from the seeded mandatory attributes such as Ledger Name, Transaction Date and Transaction Number in order to change the status of SLA from **Draft** to **Ready for Registration**.

1. Once the necessary attributes are configured and saved, the SLA status changes to **Ready for Registration**.

- From the **Sub Ledger Application Summary** window, select the required SLA to be registered and click the **Actions** drop-down in the **Product Information** link and select **Download Template**. A file with the XLSM extension is downloaded to the client machine. This XLSM file maintains the template in XlaSourceSystemSetup.xlsm with Subledger Application details filled in.  
In the **Instructions** sheet, the details are explained. Note that the XLSM file must not be manually modified. The details are provided only to aid with the users' understanding of the content of the files and how it participates in the integration process.

In the **Source System** sheet, the **Name** and **Short Name** given in the **Sub Ledger Application** window are displayed.

#### Note

The **Name** or **Short Name**, which appears in the row, must have the event type name along with the Subledger Application Name following the `EVENT_TYPE_NAME_SLA_NAME` pattern, as shown in the preceding image. The **Transaction Type** name is appended with the SLA name to maintain the uniqueness of transaction types across all subledger applications. The **Short Name** is limited by AHCS specifications to 30 characters and those employed by FSDf integration for AHCS must consider this.  
In the **Transaction Information** sheet, those **Transaction Type Names** and **Short Names** against which Journal Display is set to **Yes** is displayed through the AHCS user interface.

In the **Line Information** sheet, those **Transaction Type Names**, and **Short Names** against which Journal Display is set to **Yes** are displayed through the AHCS user interface.

#### Note

The three mandatory columns are listed in a greyed area for both **Transaction Information** and **Line Information**.

- Click **Validate** in the **Source System** tab of the XLSM file to check if there are any errors in the template. Note that this step must be performed manually.

#### Note

The XLSM files must not be manually modified. If you want to make changes to the files, make the required changes using the SLA user interface and follow the steps to download the template again.

- Click **Generate ZIP**, in the **Source System** tab of the XLSM file, to compress required content and prepare the ZIP file. Note that this step must be performed manually.
- Upload the ZIP file thus generated to your instance of AHCS. See the AHCS User-Documentation for details on how to perform this.

**Note**

In AHCS, map the **Entered Amount** and **Entered Currency** in the **Manage Accounting Attributes** window to **Transaction Amount** and **Transaction Currency** before proceeding with the configuration of accounting rules.

6. Once the generated ZIP file is uploaded to your instance of AHCS, download the data template generated by AHCS corresponding to the SLA registered through the Download Data Template Function in AHCS.  
See the [Oracle Financials Documentation](#) for details on how to perform this.
7. Click **Register** from the **Actions** list.
8. Drag the data template generated by AHCS File from your instance of AHCS into the window.  
Alternatively, you can click **Browse** and select the file.  
After successful completion, the SLA definition is registered.

## 13.2 Configuring an SLA

SLA Configuration is done to create the connectors.

To configure an SLA, complete the following steps:

1. Navigate to the **Sub Ledger Application Summary** window and for the selected SLA, click **Product Information**.
2. Define the **Header Mapping** and **Line Mapping**.  
For more information, see the [Adding a Subledger](#) section.

### 13.2.1 Ledger Name Assignment

For Ledger Name Assignment, select the ledgers relevant to the subledger application and the catalog attributes to perform ledger name assignment. Also, select the default ledger for the SLA. The ledger names are fetched from ERP. Each SLA can now have multiple ledger names configured based on the attributes.

Click **Configure** to configure the SLA. Post this, the SLA status changes to **Configured**.

**Figure 13-2 Ledger Name Assignment**

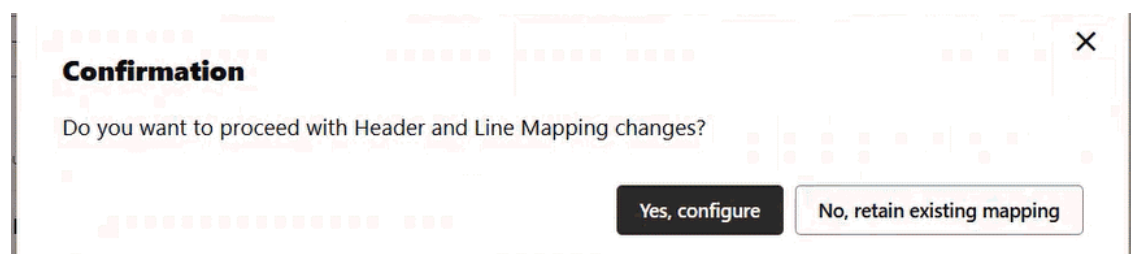

## 13.3 Publishing SLAs

Use the SLA Publish function to create the pipeline for an SLA.

To create a pipeline for an SLA, complete the following steps:

1. Select the SLA and click **Product Information**.
2. Navigate to **Review** tab after defining **Header Mapping** and **Line Mapping**. For more information, see the [Adding a Subledger Application](#) section.
3. Click **Publish** to create an **Execution Pipeline** for the SLA.

To access the pipeline, navigate to the **Sub Ledger Application** window and select the required SLA. The **Process Management** link will be available for the selected SLA.

For more information, see the [Managing Data section](#).

#### **Note**

Simultaneous execution of data publishing tasks via the following should NOT be performed:

- Journals-based SLAs
- Events-based SLAs based on the same contract and contract-transaction entities

This operational discipline should be manually practised presently.

#### **Note**

When data is published through SLA, the processing and reporting of data will work strictly based on the grain-appropriate entities.

#### **Note**

Before you use the SLAs published in the AFCS application, unpublish, reconfigure, and then publish again to ensure that the process is up to date. For more information, see [Unpublishing SLAs](#).

## 13.4 Ledger Configuration

Before you execute a SLA, ensure that both **Product Information** and **Ledger Configuration** are complete (show 100%).

You must perform ledger configuration each time a change to ledger assignment is done.

To perform ledger configuration, click the bar next to **Ledger Configuration** to launch the configuration UI. The headers are pre-populated based on the selections you have made while performing Ledger Assignment. Data is pulled from either the dimension table or from the seeded LOV (List of Values) table. Depending on whether the dimension table or LOV tables have data, the UI presents drop-down lists or text boxes for you to select or enter values for the attributes, respectively.

The configuration specifies precedence using the if, else if, else logic. This means, you specify the first combination with values for the attributes. If this condition is not satisfied, the next combination is executed, and so on, until the final option is reached which is assignment to the default ledger (user- specified). You can select a maximum of 30 attributes per combination and an unlimited number of combinations.

Depending on your access privilege, you will see the **Save** and **Apply** buttons. Users belonging to AFCSBUGRP can only save the changes. Users belonging to the AFCSAPVRGRP can apply the changes. Before saving the changes, AFCS performs validations such as ensuring duplicate combinations are not present, all mandatory fields have values, and values chosen are validated and should not exceed limits set by Data Catalog.

Note that when one user is applying changes, another user cannot modify the same until the changes being applied are complete. After configuring the ledger, the SLA can be executed and based on the ledger configuration specified, records will be assigned with ledger name.

The ledger configuration can be defined only for the following conditions:

- The SLA should be in **Configured** or **Available** status.
- There should be more than one ledger selected during ledger assignment in the SLA.
- Only distinct attributes used in ledger assignment will be available in the ledger configuration UI.

After configuring the ledger, the SLA can be executed and based on the ledger configuration specified, records will be assigned with ledger name.

1. Click the bar next to **Ledger Configuration** to launch the configuration UI. At this point, the ledger configuration is shown as 0%.

**Figure 13-3 Subledger Configuration for Annuity\_step 1**

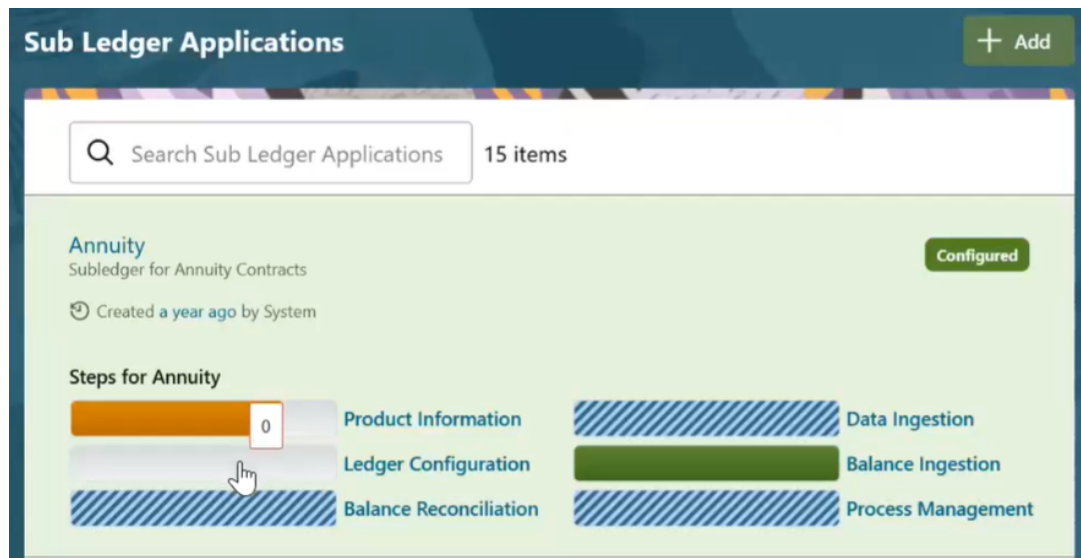

2. On the **Ledger Configuration** UI, select or enter values for the attributes for the first combination.

**Figure 13-4 Subledger Configuration for Annuity\_step 2**

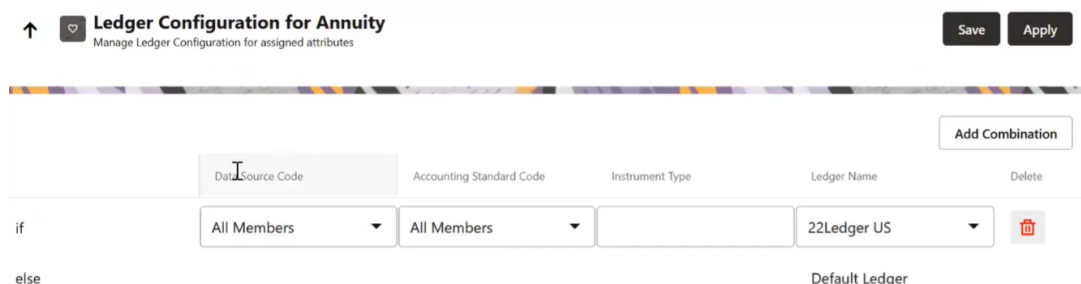

- Click **Add Combination** and enter values for attributes for the second combination. You can select a maximum of 30 attributes per combination and an unlimited number of combinations.

**Figure 13-5 Subledger Configuration for Annuity\_step 3**

	Data Source Code	Accounting Standard Code	Instrument Type	Ledger Name	Delete
if	Casa	KYGAAP		22Ledger US	
else if	Cards	DMGAAP		22Ledger US	
else				Default Ledger	

- Repeat step 3 for as many combinations as you require.
- Click **Save**. Validations are performed and the added combinations are saved.
- In the **Sub Ledger Applications** summary page, **Ledger Configuration** status is shown as 50% for this SLA.
- If you are a member of the AFCSAPVRGRP, you can click **Apply** to apply the changes. While the changes are being applied, ledger configuration status is shown as 75%.
- After all the changes are applied, the ledger configuration status shows 100%.

**Figure 13-6 Subledger Configuration for Annuity\_step 4**

**Sub Ledger Applications** + Add

Search Sub Ledger Applications 15 items

**Annuity** Configured  
Subledger for Annuity Contracts  
Created a year ago by System

**Steps for Annuity**

	Product Information		Data Ingestion
	Ledger Configuration		Balance Ingestion
	Balance Reconciliation		Process Management

**Commercial Banking** Configured  
Subledger for Commercial Banking  
Created a year ago by System

## 13.5 Unpublishing SLAs

The SLA **Unpublish** function is used to unpublish published SLAs and to reconfigure header and line mappings.

To unpublish an SLA, complete the following steps:

1. Navigate to the **Sub Ledger Application** summary page, click the SLA you want to unpublish and select **Product Information**.
2. Navigate to the **Review** tab. For more information, see the [Adding a Subledger Application](#) section.
3. Click **Unpublish** to start the unpublish process.

On successful completion, a confirmation message is displayed, and the **Publish** button is enabled.

### Note

You can reconfigure the following after unpublishing SLAs:

- a. Header and Line Mappings for custom SLAs.
- b. Grouping Levels for all SLAs.
- c. You can also update the ledger information.

## 13.6 Segment Mapping

You can map segment codes employed in your ERP Financials Cloud Service's Chart of Accounts to dimensions in AFCS. This information has to be configured once prior to initial ingestion of balance information from your ERP Financials Cloud Service into AFCS. Balance information is ingested into staging entities' General Ledger and Management Ledger, corresponding to GL and Supporting Reference Balance information using this mapping.

The Ledger Balance Data from the AHC appear in the form of CoA Segment columns. The CoA Segments are defined differently for each CoA Structure Instance and therefore, there is an option to select the appropriate dimension for each segment.

You can configure ledger-wise segment mapping, Journal Ingestion and GL Ingestion.

To begin with, first extend the required CoA or ML segments and then perform segment mapping for the required ledgers. Ledgers available in ERP are available to choose from for mapping segments.

In case of tenants upgraded from AFCS 23.08.01, the **Segment Mapping** window displays the seeded dimension names, which are a part of the data model, and it is possible to map CoA segments to dimensions as required.

**Note**

Please note that should 'Data Source' be considered relevant for inclusion as a chart of account segment, a Business Term should be added via Catalog Extension for the purpose, included in Accounting Entries or contract-transaction entities and used. The Data Source business term in the service's data structures is for internal use only and should NOT be used for the purpose.

**Note**

The way reference data on ledgers is held in Data Catalog requires that TWO mandatory identifier attributes are supplied, as can be referred from Catalog Viewer in your service instance. One of these allows alphanumeric data values and the other, numeric. In AFCS, BOTH should be assigned the same NUMERIC identifier of ledgers as available from/used in Financials Cloud.

The following is a list of predefined dimensions which must be mapped to CoA segments:

- General Ledger Account Code
- Legal Entity Code
- Branch Code
- Product Code
- Organization Unit Code
- Party Identifier
- Counterparty Reference Code
- Intercompany Identifier
- Acquisition Channel Code
- Location Code
- Line of Business Code
- Business Unit Code
- Project Code
- Ledger Identifier

**Note**

- When user configures a dimension and maps it to a CoA segment, the related business term is automatically added by the service to contract grain entities in Staging and Results. This business term cannot bear a NULL value and will have a default value 'MSG' intended to indicate that the value is explicitly 'missing'.
  - \* Such extension will also be reflected in journal grain Accounting Entries entity in Staging and Results.
- When user configures a dimension and maps it to a ML segment, the related business term is automatically added by the service to transaction grain entities in Staging and Results.
  - \* Such extension will also be reflected in journal grain Accounting Entries entity in Staging and Results.

**Note**

Only those properties that are instrument grain or finer should be mapped as Management Ledger Segments.

**Note**

Employee, Bands, Reporting Line, Fiscal Period, Date, Consent Purpose and Gender dimensions must not be mapped as COA Segments and Management Ledger Segments.

**Note**

The predefined dimensions such as **Project Code**, **Counterparty**, **Ledger Identifier**, and **Intercompany Identifier** are applicable only for **General Ledger to Management Ledger** type configuration.

**Note**

The predefined dimension **Account** is applicable only for **Management Ledger to Product Processor** type configuration.

**Note**

If you are creating new extensions post the 23.7.1 upgrade and want to use them in the GL Recon, and BCE reports, reach out to the customer support team.

In case of an upgrade to AFCS 23 C, the existing segment mappings are tagged to a seeded ledger named **Default**. The **Default** ledger mappings are used for ledgers whose segment mappings are not configured.

After the newly defined ledger-wise segment mappings are saved, Ingestion connectors (which help ingest journal entries and GL balances) are created. In addition, GL Balance pipeline and ERP Journal Ingestion pipelines are updated accordingly.

## 13.6.1 Mapping Segments

Depending on the CoA or accounting principles followed, AFCS dimensions can be mapped with the list of CoA Segments.

To map the segments, complete the following steps:

1. Navigate to **Sub Ledger Application** summary page.
2. Click the **My Profile** icon on the top-right corner and select **Administration**. Select the **Segment Mapping** option from the LHS menu.
3. From the **Select Ledger** list, select the ledger for which you want to perform segment mapping. The dimensions that are extended are available for segment mapping.
4. Click **Modify** and acknowledge confirmation message, if any.
5. Choose the required dimension and map it to the segment from the drop-down list on the right.
6. Repeat the previous step for all the dimensions you want to configure.
7. Click **Save**. All required connectors will be updated accordingly and automatically refreshed for the mappings.
8. The segment extended as CoA from Segments Extension screen will be listed in Segment mapping screen and will be mandatory if the dimension is chosen for the ledger.
9. The segment extended as ML from Segments Extension screen will be listed in Segment mapping screen as ML segment and will be disabled for modification.
10. The mapping done here will be used to replace dimension columns mapped in OOTB inbound connectors. Any change in the segment mapping done here will also modify the OOTB inbound connector mapping. The data is loaded based on this mapping into the tables of AFCS.

### Note

Specify the CoA segment as attributes in AFCS. For example, if you map the CoA Segment 1 to GL Code, all the extracts from AHCS with column header as CoA Segment 1 are loaded as GL Code in AFCS.

## 13.6.2 Publishing COA or ML Segments

This section provides information on how a user can extend CoA or ML segment to a given ledger.

To publish a COA or ML segment for an Action, do the following:

1. Go to the **Inbox** by clicking the **Inbox** button on the Home page  
The Inbox page is displayed.
2. Create an Issue and an Action with the Action Type as **Segments**. For more information on Issues and Actions, see [Manage an Issue](#) and [Manage an Action](#).
3. Once the corresponding details are added for an action, click **Save**.

4. Click **Submit** to submit the action for approval.  
A confirmation message is displayed. Click **OK** to confirm.  
For information about Approval of Action ( for Business Term), see the [Approval Work flow for Issues and Actions](#) section.
5. Click **Approve** to approve the action.
6. Navigate to **My Profile** on the Home page, select **Administration** from the dropdown menu.
7. Select the **Segment Mapping** tab and click **Pending** option.
8. From the available list of pending actions, select the action that you wish to publish and click **Publish**.  
Once the publish is complete, the segments will be available to be enabled for ledgers listed in the Segment Mapping user interface.

## 13.7 Accounting Balance Ingestion

AFCS has a predefined process to extract the general ledger balance from your ERP Financials Cloud Service and ingest it into AFCS. This is achieved by executing the GL Balances Process.

AFCS will support the run-time setting of **As Of Date** across the Journal and GL balance ingestion from Financials Cloud. In the case of journal data, the **AFCS Posting Date** will also be set based on the **As Of Date** set at run-time and ERP Accounting Date.

The following logic will apply:

- **As Of Date** is provided as a run-time parameter.
- **When it concerns journals data:**
  - If ERP Accounting Date is on or after run-time **As Of Date**.
  - **As Of Date** and **Posting Date** are both set to **ERP Accounting Date**.
  - If **ERP Accounting Date** is prior to run-time **As Of Date**.
  - **As Of Date** is set to the provided **As Of Date**.
  - **Posting Date** is set to **ERP Accounting Date** (indicating a back-dated journal line).
- **When it concerns GL Balance data:**
  - AFCS **As Of Date** is recorded as the run-rime **As Of Date** provided.
  - GL Balance extract jobs will not permit extraction of balance as of a prior date.

Also, as GL balance is extracted and ingested, for periods with an adjustment period, AFCS will extract, ingest and host YTD balance information corresponding to the "Adjustment period". This ensures that accurate GL balance figures are obtained and hosted even for periods with a corresponding adjustment period.

### Note

In the AFCS Standard Edition, backward flow is not applicable and therefore Balance Computation and Balance Reconciliation are not supported. For more information, see the [About Accounting Foundation Cloud Service- Standard Edition](#).

## 13.7.1 Prerequisite

ERP Journal Ingestion and GL Balance Ingestion connectors now refer to Ledger Dimension sourced from Ledger Master which should contain information on consolidation and accounting standard.

Before executing the GL Balances process, perform the following to ensure that the files are available on the ERP Financial Cloud Service:

Schedule the GL\_SR\_EXTRACT\_JOB Extract Job that is created in the BI Cloud console while saving the [AHCS Instance Details](#) and ensure that the job is completed.

## 13.7.2 GL Balances Process

The GL Balances process consists of components that perform the following tasks:

1. General Ledger Balance Extraction - Downloads extracted data files from the ERP Financial Cloud Service.
2. Balance Ingestion - Loads data from the downloaded files to AFCS.

## 13.7.3 Executing GL Balances Process

To execute the GL Balances process, complete the following steps:

1. On the **Sub Ledger Application** summary page, click the required SLA.
2. Click **Process Management** to display the list of processes linked to the selected SLA.
3. To execute, click the GL Balances process and open it in the Process Modeller canvas.
4. Click **Execute** using the **As of Date** parameter.

For more details on how to view the execution status in the Process Monitor window, see the [Managing Processes](#) section.

## 13.8 Journal Ingestion

AFCS has a configured mechanism to extract journal entries from your ERP Financials Cloud Service and ingest them into AFCS. This is achieved via a pre-configured PMF Process (ERP Journal Ingestion). Oracle recommends that you do not alter the ERP Journal Ingestion process.

"AFCS will now support usage of ERP Journal Currency Conversion Level for reporting currency balance assessment. This is in addition to Sub Ledger CCL that is already supported by the service. Please note that AFCS support for Journal CCL is based on extraction and use of journals relevant for the purpose from the ERP GL instance it is deployed with. The timing of ERP journal extraction will need to be appropriate, or pipeline tasks for such extraction will need to be repeated when GL journals are available, for the solution to function."

### Note

Balance computation processes in AFCS - journal ingestion, decomposition, revaluation and translation can be run multiple times on a business date. The service does not perform a check if such execution is requested, manually or via scheduling.

**Note****Decomposition of Journals**

AFCS supports decomposition of journals as of this release. The decomposition of journals refers to the service's built-in ability to receive journal lines from ERP prepared off events or journal lines processed or grouped or published by AFCS, and generate movement information for instrument-grain balance computation based on the following:

1. Only journal lines that meet the following criteria can be decomposed by AFCS:
  - a. Extracted through the standard ERP Financials PVOs (see the [ERP Financials Cloud Documentation](#) for details).
  - b. Ingested through the AFCS-provided ingestion mechanism.
  - c. Prepared through Accounting Hub off events or journal lines processed or grouped or published by AFCS.
2. Decomposition logic and execution are not user-configurable. AFCS matches journals received from ERP Financials Cloud FAH with sourced ones for the purpose of decomposition as follows:
  - Transaction Number and Line Numbers match  
OR
  - Transaction Number and DRCR Vector matchesThese are universally applied in all conditions.

**Note**

In the AFCS Standard Edition, backward flow is not applicable and therefore Balance Computation and Balance Reconciliation are not supported. For more information, see the [About Accounting Foundation Cloud Service- Standard Edition](#).

## 13.8.1 Prerequisite

Before executing the ERP Journal Ingestion process, perform the following to ensure that the files are available on the ERP Financial Cloud Service:

Schedule the JOURNAL\_INGESTION\_EXTRACT\_JOB Extract Job created in the BI Cloud Console while saving the [AHCS Instance Details](#) and ensure that the Job is completed.

## 13.8.2 ERP Journal Ingestion Process

The ERP Journal Ingestion process consists of components that perform the following tasks:

1. Journal Entries Extraction - Downloads the extracted data files from the ERP Financial Cloud Service.
2. Journal Entries Ingestion - Loads data from the downloaded files to AFCS.
3. ERP Source Journals- Moves the downloaded journals for further processing.
4. Journal Processor - Decomposes journals, does Balancing Line assignment and generates ML Segment code combinations.

### 13.8.3 Executing ERP Journal Ingestion Process

To view and execute the ERP Journal Ingestion Process, complete the following steps:

1. Navigate to the **Sub Ledger Application** window.
2. Select an SLA.
3. Click **Process Management** to display the list of processes linked to the selected SLA.
4. To execute, click the ERP Journal Ingestion process to open it in the Process Modeller canvas.
5. Click **Execute** using the **As of Date** parameter.

For more details on how to view the execution status in the Process Monitor window, see the [Managing Processes](#) section.

In AFCS Standard Edition, backward flow is not applicable and therefore Journal Ingestion pipeline execution is not supported. For more information, see the [About the Accounting Foundation Cloud Service- Standard Edition](#).

## 13.9 Copying a Subledger Application

To copy a subledger, complete the following steps:

1. From the **Sub Ledger Application** window, select a subledger and click **Copy**.

The **Save Subledger** window is displayed.

2. Enter the **Name** and **Short Name** and click **Save**.

All the properties are copied except the **Name** and **Short Name** as they must be unique.

For example, see the following table:

**Table 13-1 Connector Name Before and After Copy**

Connector Name Before Copy	Connector Name After Copy
AH Com Bill Contract Header AH Com Casa Header	AH (copied SLA Name) followed by Hdr1, Hdr2, and Hdr3
AH Com Commitment Header	AH (copied SLA Name) followed by Hdr1, Hdr2, and Hdr3

Similarly, for **Line Mapping**, the name after copy displays AH <SLAname> Ln1.

The **EDD Name** is also replaced with the copied name in the Connector Window in the AH SLA <SLA name> Header and AH SLA <SLA name> Line Format.

3. The copied SLA can be viewed in the **Sub Ledger Application** summary page for further configuration.

## 13.10 Executing the SLA Pipelines

The SLA pipelines are auto-generated during the SLA **Publish** process with all required components for event posting. The auto-generated process names start with **ERP Integration for** followed by the SLA name.

For example, For Passthrough, the Process Name is **ERP Integration for Passthrough**.

## 13.10.1 Prerequisite

Before executing the SLA pipelines, ensure that the respective SLAs are published, status is **Available** and **Ledger Configuration** progress bar shows 100%.

## 13.10.2 SLA Pipeline Process

Each SLA pipeline process consists of components that perform the following tasks.

1. **Event Grouping and Extraction Connectors** - Extracts Header and Line Information.
2. **Event Posting**: Compresses Header and Line Data into a ZIP File, uploads the ZIP File to UCM, schedules the ESS job, and monitors the status.

### Note

Even if there are no **Header** or **Line information** available for processing the event posting component in the PMF pipeline will be successful with appropriate warning.

3. **Persists Events**: If Event Posting is successful, the Header information is persisted in the process area. This data will be used to exclude posted records and submit only incremental data during multiple runs on an SLA on the same date.
4. **Capture Posted Source Records**: It will capture the source records which are being posted to ERP.

### Note

If the process pipeline fails for unknown reasons, ensure to resume the current pipeline execution instead of re-execution.

## 13.10.3 Executing SLA

To view and execute the SLA pipelines, complete the following steps:

### Note

Ensure to execute **Account Load Run Map Population** pipeline or **Policy Load Run Map Population** pipeline before executing all Banking and Insurance Transaction SLAs respectively.

1. Navigate to the **Sub Ledger Application** summary and select the required SLA.
2. Click **Process Management** to display the list of processes linked to the selected SLA.
3. To execute a pipeline, click the required process to open it in the Process Modeller canvas.
4. Click **Execute** using the **As of Date** parameter.

The **Process Modeller Summary** Window is displayed.

For more details on how to view the execution status in the Process Monitor window, see the [Managing Processes](#) section.

## 13.11 Integration with Oracle Applications

This section explains the pre-built integration with other Oracle Applications.

### 13.11.1 Integration with Oracle Enterprise Data Management Cloud Service

**Enterprise Data Management Cloud Service (EDMCS)** is an Oracle Cloud application designed to centrally manage and govern enterprise data across business applications. It provides a unified platform for creating, maintaining, and sharing master data such as dimensions, hierarchies, properties, and mappings.

Key features of EDMCS include:

- Centralized data governance with audit tracking
- Support for multiple hierarchies and viewpoints
- Role-based access and workflow approvals
- Integration with Oracle and non-Oracle systems
- Simplified modelling of enterprise structures with drag-and-drop interface

This section outlines the steps required to source dimension-related data from EDMCS into AFCS, a key capability for managing dimensions within AFCS.

You can significantly save the efforts required to manage dimensions in AFCS if those dimensions are already available and maintained in EDMCS within another application, such as *Oracle Cloud ERP*. A dimension from an existing EDMCS application—like *Oracle Cloud ERP*—can be subscribed into the EDMCS application for AFCS. This eliminates the need to manage these existing dimensions independently for AFCS.

For detailed instructions on setting up such subscriptions, refer to the [EDMCS User Guide](#).

#### 13.11.1.1 Pre-Configured Standard Dimensions

The following dimensions are delivered by default in EDMCS and are ready for use:

**Table 13-2 Pre-Configured Standard Dimensions in Use**

Dimension	Purpose
Product	Defines products or services offered by the organization.
Project	Captures details of specific projects or initiatives.
Data Source	Identifies the origin of data within the system.
Business Segment	Represents major business divisions or market segments.
Line of Business	Groups related products/services under a business line.
Transaction Type	Classifies financial or operational transactions by type.
Organization Unit	Represents organizational entities such as departments or regions.
Product Type	Categorizes products into high-level types or families.

**Table 13-2 (Cont.) Pre-Configured Standard Dimensions in Use**

Dimension	Purpose
General Ledger	Stores chart of accounts and financial account structures.
Legal Entity	Maintains information about registered legal entities.

**Note**

These dimensions can be directly used or customized by adding, renaming, or restructuring nodes to suit specific business requirements.

### 13.11.1.2 Validations in EDMCS

EDMCS automatically enforces two critical validation rules when working with **alternative hierarchies** inside a dimension.

#### 1. Leaf Node Consistency Across Alternative Hierarchies (Bottom Node Hierarchy Check)

- **Purpose:** All leaf nodes (lowest-level members without children) must be identical across all alternative hierarchies within the same dimension.
- **When it applies:** Only when a dimension has more than one alternative hierarchy.
- **How it works:** If "Product A" exists as a leaf node in one hierarchy, it must also appear as a leaf node in all other hierarchies for that dimension.  
Example: If *Product A* is a leaf node in one hierarchy, it must also exist as a leaf node in every other alternative hierarchy for that dimension.

#### No Duplicate Parent–Child Relationships Across Alternative Hierarchies (Intermediate Node Cannot be Shared)

- **Purpose:** The **same parent–child pair** cannot appear in more than one alternative hierarchy for the same dimension.
- **Allowed:** A node can exist in multiple hierarchies, but it **must have a different parent** in each hierarchy.  
Example: If *X* is the parent of *Y* in one hierarchy, this **exact X–Y relationship** cannot be repeated in another alternative hierarchy for the same dimension.

**Note**

These validations help ensure that alternative hierarchies are **structurally sound**, **consistent**, and **logically distinct** while maintaining alignment at the leaf-node level.

### 13.11.1.3 Managing Dimensions and Hierarchies in EDMCS

This section describes how to extend the integration between Enterprise Data Management Cloud Service (EDMCS) and AFCS, including how to add and manage dimensions, attributes, and hierarchies in EDMCS for use in AFCS.

The service includes a set of preconfigured dimensions in EDMCS. However, depending on your business requirements, you need to configure additional metadata, such as creating a new dimension or adding attributes to an existing dimension.

Review the following guidelines before creating or modifying dimensions and attributes.

- **Dimension Naming:** You can choose the name of the dimension. However, it is recommended to use the same name as the corresponding dimension in AFCS.
- **Attribute Naming:** Attribute names must match the names used in AFCS. Refer to the **Catalog** for the list of Business Terms (attributes in EDMCS). You can also find the attribute names in the **Download Specification** document.
- **Attribute Data Type:** Attribute data type should be compatible with AFCS Catalog.
- **Hierarchy Rules for Dimensions:** Dimensions with hierarchies must follow the validations listed below:

**Table 13-3 Hierarchy Rules for Dimensions**

Validation Rule	Description
Leaf Node Sharing	All leaf nodes must be shared across all hierarchies as leaf nodes.
Intermediate Node Uniqueness	Intermediate nodes must be unique within a dimension.
No Sharing Within Hierarchy	A node can appear only once within the same hierarchy.

The following values are generated automatically using EDMCS expressions:

1. **Child Node Id (Child Numeric Identifier):** Returns the numeric identifier of the current node using the AFCS Node ID property.

```
{
  "statements":
  [{"type": "return", "expression": {"type": "node", "id": "node", "invoke":
  {"type": "properties", "invoke":
  {"type": "propertyValue", "id": "ca27fb33-1361-493c-95f6-aabd1218b945"}}}}}]}
```

2. **Parent Node Id (Parent Numeric Identifier)**

```
{
  "statements":
  [{"type": "if", "condition": {"type": "node", "id": "node", "invoke":
  {"type": "properties", "invoke":
  {"type": "propertyValue", "id": "f803899c-8117-41c4-99dc-0f413849656d", "invoke":
  {"type": "equals", "argument":
  {"type": "intLiteral", "value": 1}}}}}, "statements":
  [{"type": "return", "expression":
  {"type": "intLiteral", "value": 0, "invoke":
  {"type": "toNumericString", "padLength":
  {"type": "intLiteral", "value": 0}}}}}], "else":
  {"type": "else", "statements": [{"type": "return", "expression":
  {"type": "node", "id": "node", "invoke": {"type": "parent", "invoke":
  {"type": "properties", "invoke":
```





```

{"type":"not"}}}], "statements":
[{"type":"comment","value":"If this is not a bottom node then skip the
validation"}, {"type":"return","expression":
{"type":"booleanLiteral","value":true}}], "elseifs":
[{"type":"elseif","condition":{"type":"node","id":"node","invoke":
{"type":"actions","invoke":{"type":"any","predicate":
{"type":"actionPredicate","statements":
[{"type":"action","id":"action","invoke":
{"type":"type","invoke":{"type":"isRemove"}}}}}}}], "statements":
[{"type":"comment","value":"If it is a Request Remove Action then prevent
it if this is the last location under the top node. \nNote: this requires
visualized mode AND assumes no implicitly shared nodes"},
{"type":"return","expression":{"type":"node","id":"node","invoke":
{"type":"locations","excludeImplicitShares":
{"type":"booleanLiteral","value":false},"sort":
{"type":"booleanLiteral","value":false},"invoke":
{"type":"filter","predicate":{"type":"nodePredicate","statements":
[{"type":"node","id":"thisNode","invoke":{"type":"properties","invoke":
{"type":"propertyValue","id":"b3ef0bbe-8f21-4ba5-ad81-
d5663f6fb6e0","invoke":
{"type":"equals","argument":{"type":"node","id":"node","invoke":
{"type":"properties","invoke":
{"type":"propertyValue","id":"b3ef0bbe-8f21-4ba5-ad81-
d5663f6fb6e0"}}}}}}}}}],
"invoke":{"type":"size","invoke":{"type":"greaterThan","argument":
{"type":"intLiteral","value":1}}}}}}}], "else":
{"type":"else","statements":
[{"type":"return","expression":{"type":"booleanLiteral","value":true}}}}]
}

```

- Intermediate Nodes Cannot be Shared- Ensures that only bottom nodes can be shared, and intermediate roll up nodes cannot be shared between hierarchies.

```

{
  "statements": [{"type":"if","condition":
  {"type":"node","id":"node","invoke":
  {"type":"properties","invoke":
  {"type":"propertyValue","id":"e75ab694-50b7-40b8-86d0-50f07d9ae8a3","invoke
  "":
  {"type":"equals","argument":
  {"type":"booleanLiteral","value":false},"invoke":
  {"type":"and","argument":{"type":"node","id":"node","invoke":
  {"type":"locations","excludeImplicitShares":
  {"type":"booleanLiteral","value":false},"sort":
  {"type":"booleanLiteral","value":false},"invoke":
  {"type":"size","invoke":{"type":"greaterThan","argument":
  {"type":"intLiteral","value":1}}}}}}}], "statements":
  [{"type":"return","expression":
  {"type":"booleanLiteral","value":false}}], "else":
  {"type":"else","statements":[{"type":"return","expression":
  {"type":"booleanLiteral","value":true}}}}]
}

```

- No Sharing Within Hierarchy- Within a hierarchy (Top Node) a node can only be present in one location.

```
{
  {
    "statements": [{ "type": "return", "expression":
      { "type": "node", "id": "node", "invoke":
        { "type": "locations", "excludeImplicitShares":
          { "type": "booleanLiteral", "value": false }, "sort":
          { "type": "booleanLiteral", "value": false }, "invoke":
          { "type": "count", "predicate": { "type": "nodePredicate", "statements":
            [ { "type": "node", "id": "thisNode", "invoke": { "type": "properties", "invoke":
              { "type": "propertyValue", "id": "b3ef0bbe-8f21-4ba5-ad81-
d5663f6fb6e0", "invoke":
                { "type": "equals", "argument": { "type": "node", "id": "node", "invoke":
                  { "type": "properties", "invoke":
                    { "type": "propertyValue", "id": "b3ef0bbe-8f21-4ba5-ad81-
d5663f6fb6e0" } } } } } } ] },
              "invoke": { "type": "lessThanOrEqual", "argument":
                { "type": "intLiteral", "value": 1 } } } } } } ] }
    }
  }
}
```

For more information on custom validations, see [EDMCS User Guide](#).

### Adding New Dimensions

For more information on adding dimensions, see [EDMCS User Guide](#).

### Adding a Property to an Existing Dimension

For more information on adding a property, see [EDMCS User Guide](#).

### Adding an Existing Property to a Dimension

For more information on adding an existing property, see [EDMCS User Guide](#).

## 13.11.1.4 Steps for Integrating EDMCS with AFCS

This interface allows users to provide necessary credentials and connection details to integrate EDMCS (Enterprise Data Management Cloud Service) with the Accounting Foundation Cloud Service. It allows AFCS to fetch and utilize dimension metadata for applications.

### Note

Before getting started, users must submit a Service Request (SR) with My Oracle Support to have the EDMCS URL whitelisted.

1. From the **AFCS Home** page, click the **My Profile** icon, and click **Administration**.
2. Click **EDMCS Configuration** and Configure Enterprise Data Management Cloud Service details are displayed.

**Figure 13-7 EDMCS Configuration Details**

3. Enter the credentials to access the EDMCS.

**Table 13-4 Share the credentials to access the EDMCS**

Field	Description
URL to access EDMCS	Enter the URL for your EDMCS instance in this field. This field is required. (e.g., https://<prod>.oraclecloud.com). Enter 500 or fewer characters.
Version	Enter the version of your EDMCS instance in this field. This field is required. (e.g., 24.04.30).

**Note**

Enter 20 or fewer characters.

4. Select **Authenticate Using?** dropdown. Select the preferred authentication method.
  - Two options are available:
    - **Password**
    - **Access Token**
5. **Option 1: Password Authentication**  
Once **Password** is selected:
  - Provide the **Username** and **Password** for EDMCS.

**Table 13-5 Password Authentication**

Field	Description
Username	EDMCS service account username. Enter 100 or fewer characters.
Password	Corresponding user password. Enter 255 or fewer characters.

**Note**

Ensure the user has the necessary EDMCS API access privileges.

**6. Option 2: Access Token Authentication**

If **Access Token** is selected:

- Provide the full access token in the field:

**Specify the token****Note**

Token must be valid and scoped for EDMCS APIs. Ensure the token hasn't expired.

**7. Click **Save and Get Application** to:**

- Validate the connection
- Fetch available EDMCS applications and their dimension structures

**Note**

If connection or credentials are invalid, appropriate error prompts will guide the user.

**8. Once saved, the **Mark As Done** option will be enabled.****Figure 13-8 Dimension Mapping**

The screenshot shows the 'Configure Enterprise Data Management Cloud Service' interface. At the top right, there is a 'Mark As Done' button. Below the title, there is a dropdown menu for 'Select the EDMCS App' with 'AFCS-QA' selected. A search bar is present with the text 'Search by dimension name'. Below the search bar, there are several dimension mapping options, each with a toggle switch and a dropdown menu for mapping:

Dimension	Toggle	Mapping
Product	On	Mapped to Product
Legal Entity	On	Mapped to Legal Entity
Product Test	Off	Mapped to Product
Project	Off	Mapped to Project
Branch	Off	Mapped to Branch
Rate Plan Dim	On	Mapped to Rate Plan

**9. Select the required **Dimension**.****Note**

The pre-built dimensions will be auto-mapped if the logical names are same as the names existing in the EDMCS application.

**10. Click **Mark As Done** located at the top right to complete the integration setup.****11. After saving successfully, the **EDMCS** will be created.**

**Note**

Dimensions must always be in synchronization between EDMCS and AFCS application else it will display a validation error.

**Verifying PMF Executions**

1. From the **AFCS Home** page, select **Process Orchestration** and navigate to the Process Modeller page.
2. In the Search bar, locate and click on **EDM\_DIM\_EXPORT\_LOAD**. All selected dimensions will appear.

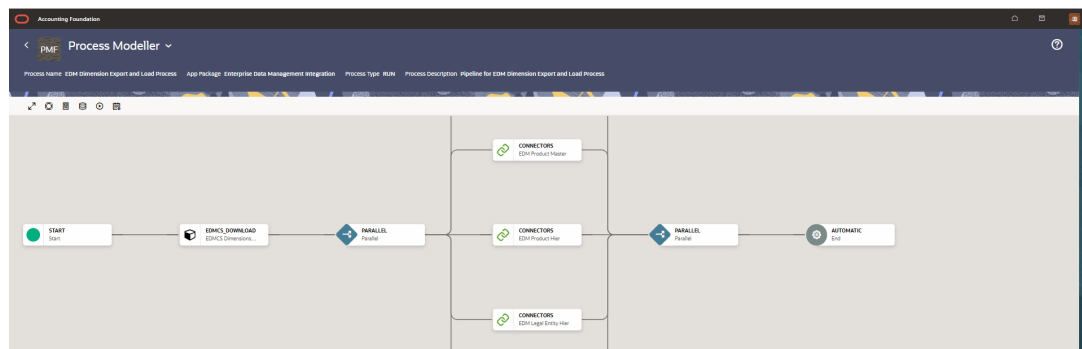
**Figure 13-9 EDMCS Pipeline**

3. Click **Execute** icon.
4. Select the **Execution Type** and enter the **Object ID**.
5. Click **Execute** again to run the process. The Process execution has started successfully message is displayed.
6. Navigate to the **Process Monitor** page.
7. Check the status for EDM:
  - **Completed** → Process execution is successful.
  - **Failed** → Double-click the failed record to view **Execution Logs** for troubleshooting.
8. Click **Execution Logs** to view the logs.

# 14

## SLA Configuration Using New User Interface

This section provides information on creating an SLA, and copying an SLA, deleting and SLA and unpublishing an SLA using the new user interface.

1. Login to the AFCS application.
2. On the Home page, click **SLA Configuration** link. The SLA Summary page is displayed.

### 14.1 Creating an SLA in the New User Interface

To create an SLA, follow these steps:

1. Login to the AFCS application.
2. On the Home page, click **SLA Configuration** link. The SLA Summary page is displayed.
3. Click **Create SLA** button and the Set Up New SLA page is displayed.
4. From the Set Up New SLA page, click **Create SLA** and Define Product Information page is displayed.
5. Provide the following **Details** information:
  - Specify a unique Subledger Application Name.
  - Specify a unique code for Subledger Application.
  - Select the Event Class as **Transaction** or **Passthrough**. Based on the selected **Event Class**, the **Products** or **Entity** list is updated.

#### Note

Users must mark the Journal intent data in the Stage Accounting Entries as **P** for the SLA process to be executed.

- Select the **Product or Entity**.
- The **Publish Future Dated Events** option specifies if future-dated journals (where header event date corresponding to accounting date in FAH/GL is greater than as-of date) will be published or not. By default, this option is enabled. If this option is disabled, AFCS will only publish non-future-dated journals from what has been sourced.

#### Note

It is recommended to not modify this option after it is set. If there is a business-case to change this, raise a service request on [My Oracle Support](#).

- By default **Yes** is selected to group the events. Select **No** to post the line records as is without journal grouping.
- Click **Save** to save the Product information.

- Click **Continue**.  
Acknowledge the confirmation message. The SLA details are successfully saved.  
The status of the subledger changes to **Draft** and **Created By** details are added.
6. Provide the following **Event Types** details:
- From the list of event types available, select the required event type or use the search box to search for an event type.
  - Click **Add Event Type** to add your own event type and provide the following details.
    - **Name**
    - **Code**
    - **Description**
    - **Event Class**
  - Click **Save**. A new event type is added to the list of Event Types.
  - Click **Save and Add another Event Type** to add another new event type.
  - Click **Export** icon to export the list of event types added in the SLA.
  - Click **Continue**.

**Note**

You can add or modify the Event Type for an SLA even after it is registered or in configured status. In case of modification or addition, the same has to be performed in the ERP as well.

**Note**

If an Event Type is added or modified after SLA is registered/configured and if the same Event Type is not present in the ERP, SLA execution fails. To proceed further, you need to add or modify the same Event Type in the ERP and re-run the SLA.

7. Provide the following **Attributes** details:
- a. From the list of attributes available in the application, select the required attribute use the search box to search for an attribute.
  - b. Click **Add Attribute** to add your own attribute and provide the following details:
  - c. Enter the following details:
    - Name
    - Physical Name
    - Data Type
  - d. Select the **Attribute Type**. You have **Header** and **Line** as options.
  - e. Select the **Event Class**. You have **Passthrough** and **Transaction** as options.
  - f. Click **Save**. A new attribute is added to the list of Attributes.
  - g. Click **Save and Add another Attribute** to add another new attribute.
  - h. Click **Export** icon to export the list of attributes added in the SLA.

- i. Click **Submit**.
8. From the SLA Summary page, search and navigate to the updated SLA.
9. On the Set up New SLA page, select **Register SLA**

**Note**

Before proceeding with Header Mapping, you must register the SLA. For more information, see the [Registering Accounting Content with your ERP Service section](#).

10. Follow the steps mentioned on the Import ERP Data page, to register an SLA.
11. Click **Continue** and the Map Header Data page is displayed.
12. Provide the following **Header Mapping** details:
  - a. From the Map Header Data page, click **Map Column** and the Map columns for Future Transactions - Header Mapping window is displayed.
  - b. Enter the **Header Data Mapping Name** in **Specify the Header Data Mapping Name** field. This is auto-populated. You can change it as required.
  - c. Define the mapping from the list of subledger attributes and account attributes using the corresponding check boxes. Only selected subledger attributes will be used.
  - d. From the **Account Attributes** drop down, search for the attribute that you wish to add or modify, the search result is displayed.

**Note**

You must use a Header ID which is unique only within a Business or an As-of-date for Subledger applications.

- e. Click **Mark as Done**.

**Note**

Here, you can see the list of product tables and the respective columns. Ensure that the data selected in the product and transaction tables is available in the staging tables too.

- f. Click **Continue** and Map Line Data page is displayed.
13. Provide the following **Line Mapping** details:
  - a. From the Map Line Data page, click **Map Column** and the Map columns for Future Transactions - Line Mapping window is displayed.
  - b. Select the required **Data Mapping** . Here, you can see the list of transaction tables and the respective columns. Ensure that the data selected in the product and transaction tables is available in the staging tables too.
  - c. Specify the header data mapping name in **Specify the line data mapping name** field. This is auto-populated. You can change it as required.
  - d. Define the mapping from the list of subledger attributes and account attributes using the corresponding check boxes. Only selected subledger attributes will be used.

**14.** Click **Continue**.

In **Assign Ledger**, select the ledgers relevant to the Sub Ledger Application and the assignment attributes to perform ledger name assignment. Also, select the **Default Ledger** for the SLA. The ledger names are fetched from ERP. Each SLA can now have multiple ledger names configured based on the attributes.

**Note**

Only the Text related header attributes are displayed for selection.

**Note**

In case of multiple ledger assignment, users must configure multiple ledger only from the **Ledger Configuration** legacy User Interface.

For more information, see the [Configuring a SLA section](#).

**15.** Click **Submit SLA Configuration** and the status of SLA is displayed as **Configured** in the SLA Summary page.**16.** Click **Publish**.

The SLAs which have connectors are auto generated. You cannot modify seeded connectors. A confirmation message is displayed after the SLA is published. The status of the SLA changes to Available.

## 14.2 Publishing an SLA Using New User Interface

The SLA **Review and Publish** function is used to publish the configured SLAs.

To publish an SLA, complete the following steps:

1. Login to the AFCS application.
2. On the Home page, click SLA Configuration link and the SLA Summary page is displayed.
3. Search and select for an SLA which is in **Configured** status.
4. On the SLA tasks you need to complete page, click **Review and Publish** to start the publish process.
5. On successful completion, the SLA status changes to **Available**.

## 14.3 Unpublishing an SLA Using New User Interface

The SLA **Unpublish** function is used to unpublish published SLAs and to reconfigure header and line mappings.

To unpublish an SLA, complete the following steps:

1. Login to the AFCS application.
2. On the Home page, click SLA Configuration link and the SLA Summary page is displayed.
3. Search and select for an SLA which is in **Available** status.
4. On the Product Information page, click **Un-publish SLA** to start the unpublish process.

On successful completion, a confirmation message is displayed, and the **Publish** button is enabled.

**Note**

You can reconfigure the following after unpublishing SLAs:

- a. Header and Line Mappings for custom SLAs.
- b. Grouping Levels for all SLAs.
- c. You can also update the ledger information.

## 14.4 Copying an existing SLA in the New User Interface

To copy an existing SLA, follow these steps:

1. Login to the AFCS application.
2. On the **Home** page, click **SLA Configuration** link.
3. From the SLA Summary page, search for the SLA that you wish to copy.
4. From the **Actions** option, select **Duplicate** to copy an existing SLA. The Duplicate SLA window is displayed.
5. Enter the **SLA Name**, **SLA Code** and the **SLA Description** and click **Save**. A confirmation message is displayed and the copied SLA is displayed in the SLA Summary page.

## 14.5 Deleting an SLA in the New User Interface

To delete an SLA, follow these steps:

Users can only delete an SLA which is **Draft** status.

1. Login to the AFCS application.
2. On the **Home** page, click **SLA Configuration** link.
3. From the SLA Summary page, search for the SLA that you wish to delete.
4. From the **Actions** option, select **Delete** to delete an SLA which is in Draft status.

# 15

## Managing Data Catalog

Data Catalog is the logical representation of the underlying data model, which is contextualized by the metadata to enable a better understanding of the data model and the enterprise-wide data. Data structures underlying AFCS are delivered, deployed, viewed, extended and managed with associated metadata through Data Catalog. The Data Catalog has the following traits:

- Representation of data structures in Business Terms.
- Representation of data structures in technical terms, including their physical manifestation and properties.
- Alignment of data structures with domains.
- Metadata, including data model and quality constraints.

This section provides information about how you may access, view, extend and manage your Data Catalog.

### Note

"In AFCS, Users are expected to use the User Interface primarily which consists of only logical names. All the configuration in the Catalog is done based on the logical names".

For more information on defining data forms for a pre-specified set of entities using the Data Management Interface, see the Data Maintenance Interface section in the [Data Foundation Cloud Service User Guide](#).

### 15.1 Accessing the Catalog

You can access the Data Catalog by navigating to the **Data Catalog** page.

To navigate to the **Data Catalog** page, complete the following steps:

1. On the **Home** page, select **Browse Data Catalog**. The **Data Catalog** page is displayed. The deployed domain, its corresponding subject areas, and all the relevant entities are listed on the **Data Catalog** page by default.
2. Click the **Previous** or **Next** arrow buttons to navigate through the complete list of entities.

For more information, see the *OFS AFCS Data Catalog User Guide*.

### 15.2 Viewing Catalog Content

Catalog Viewer is the viewing framework of the Data Catalog. Use the catalog viewer user interface to see and understand the catalog components equivalent to the data model granularity.

For more information about the catalog viewer, see the Catalog Viewer section in the *OFS AFCS Data Catalog User Guide*.

## 15.3 Extending Catalog Content

The Catalog Extension feature allows you to extend the seeded catalog contents to support a new or client-specific business use cases including accounting integration use cases. You can create new definitions or customize the existing definitions based on context.

For more information about extending the Data Catalog, see the Catalog Extension section in the *OFS AFCS Data Catalog User Guide*.

### Note

When a new dimension is configured and mapped to a CoA or an ML segment, the corresponding Business Term is automatically extended to the relevant Staging and Results entities (contract or transaction Grain). For more information, see the [Segment Mapping](#) section.

# 16

## Managing Data

This section provides details about exchange of data between AFCS and external systems. This is facilitated through the logical abstraction of the Data Catalog exposed as Application Data Interfaces (ADI). External Data Descriptors (EDD) are defined through the user interface, which also facilitate the mapping of EDDs to ADIs and forming Connectors.

### Related Topics:

- [External Data Descriptor](#)
- [Connectors](#)

### 16.1 File Operations

The file operation process enables you to add files that must be processed to the object store. You can upload any CSV, XLSX, and Text file that you wish to be stored in the object store, which can be processed later.

#### Note

In the User Interface, the file status will be updated to **Available** only when the PAR URL has been downloaded through the File Operations User Interface, or when the file is actively being consumed by a PMF process.

The file status information:

- **Empty/Blank** and **Uploading** cannot be downloaded through the File Operations User Interface.
- The files that are system generated with these statuses **Scanning**, **Unscannable**, **Initialized**, and **Scan Failed** can be downloaded through the File Operations User Interface. However, manually uploaded files cannot be downloaded through the File Operations User Interface.

To upload a file, complete the following steps:

1. On the AFCS Home page, click the **My Profile** icon and select **Administration**.
2. Click **File Operations**.
3. Click **Upload File**.

The **Generate Pre-Authenticated URL** window is displayed.

4. Enter the **File Name**.
5. Select the file format from the drop-down list.

The supported file types are: CSV, XLSX, Text, and Zip.

6. Enter the file size (in bytes) as seen on the disk.  
To add more files, click **Add** and repeat the steps.
7. Click **Generate**.

This generates a PAR (pre-authenticated request) URL which is valid for 24 hours. This PAR URL is used to upload the file into the object store.

For more information on using the PAR URL, see the Working with Pre-Authenticated Requests section in [Using Preauthenticated Requests](#).

8. An entry for the PAR URL you just created appears on the File Operations page.

The search feature provides you multiple options to search for a file based on name, creation date, and so on. You can also sort the list by name and creation date in ascending or descending order.

You can also perform searching a file using REST API. For more details, refer [Searching a File](#)

You can download a file using REST API. For more details, refer [Generating PAR URL for File Download](#).

## 16.2 Data Ingress

This section describes about the different Data Descriptors.

### Note

Partitioning of physical tables are decided based on the initial load date for any entity. Hence, users are advised to load any entity from the initial load date. Loading data for a prior date after loading the data for later date will receive an error.

### 16.2.1 External Data Descriptor

External Data Descriptors (EDD) are definitions of specific data content from External Data Sources (EDS). Each EDS may have a number of EDDs defined against it. EDD definitions can be used for ingesting data into AFCS Data Foundation or extracting data from it.

AFCS also supports the usage of control information while ingesting data into the Data Foundation. Such control information may also be defined as EDDs.

1. From the **Subledger Applications** page, select the required SLA.
2. Click **Data Ingestion** to define External Data Descriptors, Connectors, and view data. You can manage data ingestion by configuring sources, mapping to catalog, and required transformation.
3. Click **External Data Descriptors**. The **Summary** page is displayed.
4. Use the search functionality if you are looking for an existing EDD.
5. Click **Add** to configure additional EDDs. Provide a name and description, and select the **Datastore**. The **Data**, **Transformation**, and **Control** tabs appear based on your selection. For details, see section [Defining an External Data Descriptor](#).
6. Click **Delete** to delete an existing EDD. For details, see section [Deleting an External Data Descriptor](#).

#### 16.2.1.1 Data Tab

The following table describes the information you must provide in the Data tab when creating an EDD.

**Table 16-1 Data Tab Description**

Fields	Description
Is the file archived	By enabling this option, you can upload an archived data file to the object store as input to the AFCS data ingestion process. You can also combine multiple files into an archive and use it to load data into AFCS.
Archive file name	This field is displayed only when <b>Is the file archived</b> option is enabled. Enter the archive file name. Example: td_contracts%#MISDATE%.zip Only archives with .zip extension using standard DEFLATE algorithm is supported.
Is data files(s) encrypted?	This option allows you to indicate whether the incoming data file is encrypted. Enable this toggle only if the file you are ingesting has been encrypted using the platform's supported encryption method. When turned ON, the system will automatically decrypt the file using the configured encryption key before processing and loading the data. If left OFF, the system will treat the file as a plain (non encrypted) file.
Format for data files in archive	This field is displayed only when <b>Is the file archived</b> option is enabled. Enter the format of the data files. For example: *.csv, td_contracts%#MISDATE%.csv. <b>NOTE:</b> The supported wildcard character is *
Data File Name	You can add multiple data files to an EDD. For example, if you need to add the Term Deposits Contracts data file. There are Term Deposits Contracts data files for retail as well as corporate accounts. Therefore, to get both these details, you first add the Term Deposits Contracts data file for retail accounts, such as td_contracts%#MISDATE%_1.csv, and as the next record, add the Term Deposits Contracts data file for corporate accounts. In case the file sizes are large, it is recommended you break the file into smaller files. Optimize file size is 3 GB for each file. Example: td_contracts%#MISDATE%_1.csv
Record Delimiter	The records are stored differently in different operating systems. The available options are: <ul style="list-style-type: none"> <li>• MS-DOS</li> <li>• Unix</li> <li>• No Record Delimiter</li> <li>• Other</li> </ul> For example, select Unix.

Table 16-1 (Cont.) Data Tab Description

Fields	Description
File Format	<p>There are two options:</p> <ul style="list-style-type: none"> <li>Fixed Length: The file has records and columns with a fixed length. Each column has a predetermined and unchanging size, set when the record layout is designed, and the sum of the column sizes add up to the record size.</li> <li>Delimited: There is a separation of the records and columns using a delimiter character like a comma, semicolon, hyphen, and so on.</li> </ul> <p>For example, select Delimited.</p>
Text Qualifier	<p>A character that identifies text. Generally, double quotes are prefixed and suffixed to identify text. This is optional.</p>
Skip Number Of Records	<p>Provide the number of records to be skipped. The records are skipped from the top. Generally, this is used to skip headers.</p>
Decimal Separator	<p>The character used to identify the decimal and fractional part. Usually point (.) or comma (,)</p>
Read from template	<p>Specify if you want to use a template containing all values in the Excel file format. If the template is not available, create it manually by clicking Add, under the Data Elements. If the template is available, you can browse for the template. See the <a href="#">File EDD Template</a>.</p> <p>You can also drop the template in the area “Drop template here or click to select “.</p>
Select Template (*.xls,*.xlsx,*.csv Files Only)	<p>Click Browse and select the required template.</p>
Data Elements Name	<p>Name of the field in EDD.</p> <p>Example: Field name in a file or column name in a table.</p>
Type	<p>This shows the Data type.</p> <p>Example: String, Number, Date, EBCDIC, and so on.</p>
Length	<p>This is applicable only for the EBCDIC format. This is the length of the EBCDIC data type. In the case of a file, it is length only.</p>

**Note**

The Field name of XML type must not be more than 25 characters and for others must not be more than 30 characters.

**Table 16-1 (Cont.) Data Tab Description**

Fields	Description
Precision	This is used to specify the number of digits after the decimal point. Example: 10.3.
Format	Specify the format for columns of type date here. If left blank, a default format of DD/MM/YYYY is assumed and used.
	<div data-bbox="1143 554 1468 1125" style="border: 1px solid #ccc; padding: 10px;"> <p><b>Note</b></p> <ul style="list-style-type: none"> <li>The default format is fixed and does not change with database or system language settings.</li> <li>For data ingestion, enter the format in which date fields are provided.</li> <li>For data extraction, enter the format in which extracted date fields must be recorded.</li> </ul> </div>
Record Type Code	<p>For example, in the file extract, to represent the date, 31st January 2020, as “31/01/2020”, specify the format as DD/MM/YYYY for the date columns.</p> <p>This identifies the Record type in a file where Header, Trailer, and Data are of different record length and type. The values can be any string available in the text file. This value is only possible for the first field in a file.</p> <p>Example: The values can be DATA; CTRL to specify it is a control record.</p>

## 16.2.1.2 Control Tab

Using the Control tab, you can:

1. Reconcile between source data received and data loaded into AFCS, using the control information available from the source system. This feature is used to implement record count validation or amount reconciliation from a source file. It also allows specifying a threshold for validation. The specified threshold is compared with the difference (record count or amount) to perform the validation. The execution fails only if the difference is more than the threshold value.
2. The threshold can be an absolute or a percentage value. The connector execution process considers the threshold type while performing reconciliation.

3. Generate control information for file extracts from AFCS. Specifying control for extract EDDs generates control details, based on the configuration in the EDD. Both record count and amount value (sum, average, max, and so on) for specific columns are recorded into the control file.

**Note**

This option is applicable only for file type EDDs (ASCII and EBCDIC).

**Table 16-2 Control Tab Description**

Fields	Description
<p><b>NOTE:</b> The Reconciliation details present in separate file option cannot be modified if the option <b>Is the file archived in Data Tab</b> is enabled. For more details see <a href="#">Data Tab</a>.</p> <p>When Archive option is enabled:</p> <p>If you want to perform reconciliation, control file must always be present in the same archive as input data files and should be a separate file.</p> <p>The control file should have only two columns that are Control Name and Expected Value.</p> <p>When <b>Separate File</b> is selected as <b>Yes</b>.</p>	
File Name	Specify the name of the file.
File Format	<p>There are two options:</p> <ul style="list-style-type: none"> <li>• <b>Fixed Length:</b> The file has records and columns with a fixed length. Each column has a predetermined and unchanging size, set when the record layout is designed, and the sum of the column sizes add up to the record size.</li> <li>• <b>Delimited:</b> There is a separation of the records and columns using a delimiter character like a comma, semicolon, hyphen, or so on.</li> </ul> <p>In the previous example, select Delimited.</p>
Column Delimiter	<p>If the File Format is selected as Fixed Length, the Column Delimiter would be Other by default.</p> <p>If the File format is selected as Delimited, the following options are available in the drop-down list.</p> <ul style="list-style-type: none"> <li>• Other</li> <li>• Space</li> <li>• Semicolon</li> <li>• Comma</li> <li>• Tab</li> </ul> <p>In the previous example, select Comma.</p>
Record Type Code	<p>Used to uniquely identify a record within a file. A financial institution sometimes provides files that have data and control records within the same file. In such a case, to distinguish between data record and control record, the first field is Record Type. It has a specific value to identify that. Here, specify the value that identifies the data. Values can be 'DATA' and so on. For the Control record, the value is specified under the Control tab. Only the first field of a file is used for Record Type.</p>

**Table 16-2 (Cont.) Control Tab Description**

Fields	Description
Record Delimiter	<p>The records are stored differently in different operating systems. The following options are available:</p> <ul style="list-style-type: none"> <li>• MS-DOS</li> <li>• Unix</li> <li>• No Record Delimiter</li> <li>• Other</li> </ul> <p>For example, select Unix.</p>
Skip number of records	<p>Provide the number of records to be skipped. The records are skipped from the top. Generally, this is used to skip Headers. Example: If you specify this as 1, the first row in the file will be ignored.</p>
Text Qualifier	<p>A character that identifies text. Generally, double quotes are prefixed and suffixed to identify text. This is optional.</p>
Decimal separator	<p>Specify up to which decimal digit you want to view the result.</p>
Record Type Length	<p>The length of the record type value to pick up the correct record. For example, if the control record is "DATATotal Records400" and DATA is the Record type, the length is '4'. This is applicable only for Control records that are of fixed length.</p>
Control Name Length	<p>Based on the previous example, the Control name is "Total Records". Therefore, the Control Name Length is '13'.</p>
Control Value Length	<p>Based on the previous example, the Control value is 400. Hence, the length of the control value is '3'.</p>
When <b>Separate File</b> is selected as <b>No</b> .	
When Are Reconciliation details present in Separate File option is disabled, the below fields will be enabled.	
Is Reconciliation file encrypted?	<p>This option indicates whether the reconciliation file is encrypted. Enable this toggle if the reconciliation file has been encrypted. When turned ON, the system will decrypt the file using the configured encryption key before processing. If left OFF, the file will be treated as a plain (non encrypted) file.</p>
Record Type Code	<p>Used to uniquely identify a record within a file. A financial institution sometimes provides files that have data and control records within the same file. In such a case, to distinguish between data record and control record, the first field is Record Type. It has a specific value to identify that. Here, specify the value that identifies the data. Values can be 'DATA' and so on. For the Control record, the value is specified under the Control tab. Only the first field of a file is used for Record Type.</p>
Control Value Length	<p>Based on the previous example, the Control value is 400. Hence, the length of the control value is '3'</p>

**Table 16-2 (Cont.) Control Tab Description**

Fields	Description
Control Name Length	Based on the previous example, the Control name is "Total Records". Hence, the Control Name Length is '13'.
Controls	
Control Name	Specify the name of the control.
Aggregation Method	Select either Aggregation Method or Count. The supported aggregation methods are as follows: <ul style="list-style-type: none"> <li>• Min</li> <li>• Max</li> <li>• Average</li> <li>• Sum</li> </ul>
Aggregation Column Name	Select the column on which the aggregation method is applied. NOTE: For count, no column needs to be selected.
Threshold Type	This field is optional. There are two available options for threshold: percentage or absolute. If you select percentage, the reconciliation difference in percent is matched against this threshold value. If you select absolute, the absolute difference is matched against this threshold value.
Threshold Value	Specify the difference value in percent or absolute.

### 16.2.1.3 Transformation Tab

**Table 16-3 Transformation Tab Description**

Fields	Description
Transformation Type	A drop-down listing the different types of transformation supported. Currently, only Aggregation is supported.
If the Transformation Type is selected as <b>None</b> :	
Derived Data Elements	
Name	Name of the derived field in the EDD. NOTE: Field names must not be more than 30 characters.
Type	Shows the Data type of the field. Example: Varchar2, Number, Date, and so on.
Expression	When you select the <b>Add</b> option, the Specify Expression window is displayed. Here, you can select the required entities, functions, and operators. That is, you can write your expression. Enter the field name and click <b>OK</b> . Then the newly created field name is listed.
If the Transformation Type is selected as <b>Aggregation</b> :	

**Table 16-3 (Cont.) Transformation Tab Description**

Fields	Description
Derived Data Elements	
Name	Name of the derived field in the EDD. Note: Field names must not be more than 30 characters.
Type	This shows the Data type of the field. Example: Varchar2, Number, Date, and so on.
Expression	When you select the <b>Add</b> option, the Specify Expression window is displayed. Here, you can select the required entities, functions, and operators. That is, you can write your expression. Enter the field name and click <b>OK</b> . Now the newly created field name is listed.
Aggregation Properties	
Group By	This is available when Aggregation is selected.
Having	This is available when Aggregation is selected.

### 16.2.1.4 Defining an External Data Descriptor

To define a new EDD from the DIH Designer window, complete the following steps:

- From the Data Ingestion summary page, click **Add**.  
The **New** tab is displayed.
- Enter the name and description for the data descriptor, and then select **Datastore** from the drop-down list. This is the data source you had created. In this example, it is, ERP\_FILE\_EXTRACTS. The values in Defining an External Data Store example are used. The description comes up automatically.
- Click **Save as Draft** or click **Save**.
- Enter the values in the fields as described in the [Fields and their Description](#) section.
- If data needs to be reconciled post-loading, then click the **Control** tab. In this version, only the Number of Records controls is possible.
- To transform the EDD, click the **Transformation** tab.
- You can add derivation to data elements of the EDD.
  - Click **Add** to create derived data elements.
  - To edit the derived data element, click **Edit**. The **Expression** window is displayed.
  - The expression can be specified using the data elements defined in the **Data** tab and functions.
  - To delete the derived data element, click **Delete**.
- Click the **Transformation** tab and select the Transformation Type.
  - Select **Aggregation** and click **Edit** to view **Expression** window.
  - Specify the **Group by** clause and having expression, if applicable.
  - Define Derived Data Elements for the field to be aggregated under the previous tab.
- Click **Save**.

## 16.2.1.5 Modifying and Viewing an External Data Descriptor

You can edit or view existing EDDs.

### Note

You cannot edit EDDs in **Published** status.

To edit or view an EDD, complete the following steps:

1. From the EDD Summary page, select the required EDD.
2. The details of the selected EDD are displayed. You can modify or view the details.
3. Update the required details.
4. Click **Save** to save the changes made.
5. Click **Save as Draft** to save and update later.

The status shows as **Draft**.

## 16.2.1.6 Deleting an External Data Descriptor

This option only checks the higher-order object. That is, if the order has a dependency, you cannot delete it unless the dependency is removed.

For example, assume an EDD is used in a Connector. Then, unless the Connector is deleted, the used EDD cannot be deleted.

To delete an existing EDD, complete the following steps:

1. On the EDD Summary, click **Delete** corresponding to the EDD you want to delete.
2. Acknowledge the confirmation message.

The EDD details are deleted.

## 16.2.1.7 Search and Filter

Use the search and filter options to find the required information. You can enter keywords nearest to what you are looking for in the search box. You can search for an EDD using either the name, description, status, or type.

For example, enter the EDD keyword as Loan Data in the search box. The search results show the list of all EDDs containing the text 'Loan Data'.

## 16.2.1.8 Parameters in EDD Definition

While defining an EDD, the parameter can be used as a placeholder in a data filename.

**For example:** Consider a table with two columns: Account number and Balance.

**Table 16-4 EDD Parameters Example**

Account Number	Balance
A1	1000

**Table 16-4 (Cont.) EDD Parameters Example**

Account Number	Balance
A2	1000
A3	1000
A1	1000
A2	1500
A3	1500

In this example, a customer has three accounts (A1, A2, and A3).

The customer has deposited different amounts on January 1st and 2nd 2014. The CSV data files can be created for those two dates as follows:

- The account transaction for January 1st, 2014 is saved as `td_contracts_/01012014/.csv`
- The account transaction for January 2nd, 2014 is saved as `td_contracts_/01022014/.csv`

If a parameter, `MISDATE`, is defined as a Runtime, this can be used as a placeholder that substitutes date in `mmddyyyy` format. That is, the data filename can be mentioned as `td_contracts_/%#MISDATE%.csv`. When this file is called, it substitutes the date in the file name, dynamically, in the Runtime.

Parameter Data Types need not always be Runtime. They can be Constants or values like Current Date, which can also be used to substitute a value in a data filename.

## 16.2.2 Catalog Lookup Object

Catalog Lookup Object enables users to define a lookup object on top of a Target Entity, allowing them to perform lookups on database objects and populate the Target Entity based on the lookup output References.

1. From the **Subledger Applications** page, select the required SLA.
2. Click **Data Ingestion** to define Catalog Lookups, Connectors, and view data. You can manage data ingestion by configuring sources, mapping to catalog, and required transformation.
3. From the Connector Summary page, Click **Add** and the Connector canvas page is displayed.
4. Click **Source** and under **Data Descriptor**, search for the Catalog Lookup objects.
5. Drag and drop a Target ADI on the Connector canvas.
6. Right click and select **Create Catalog Lookup** to configure additional Catalog Lookups. Provide a name and description, and select the **Target Attribute**, the **Lookup Entity Type**, **Lookup Key Field**, and **Lookup Value Field**. For details, see section [Defining a Catalog Lookup Object](#)

### 16.2.2.1 Defining a Catalog Lookup Object

To define a new Catalog Lookup from the DIH Designer window, complete the following steps:

1. From the Data Ingestion summary page, click **Add**.  
The **New Connector** tab is displayed.
2. Click the Target and drag and drop the Target Entity from the available list.

3. Right click on the Target Entity and select **Create Catalog Lookup** option.
4. Enter the name and description for the Catalog Lookup, and then select **Select Target Attribute** from the drop-down list. By default, the Context Entity is the Target Entity displayed.
5. Select any one of the **Lookup Entity Type** from the available list. They are **Dimension**, **Map**, **Fact** and **Dimension as Sourced**.

**Note**

The list of entities available for the Lookup Entity types:

**Table 16-5 Lookup Entity Types**

Lookup Entity Types	Entities
Dimension	SCD Populated Dimension
Map	Mapper History
Fact	Stage Entities
Dimension as Sourced	Stage Master

6. Select the **Lookup Entity** from the drop down list and the **Lookup Key Field** is auto-populated.  
To add more Lookup key fields, click on the Lookup Key field, search for the corresponding Business Term and select them accordingly.

**Note**

Only 8 Business Terms can be selected under this field.

7. Select the **Lookup Value Field** from the drop down list.
8. Click **Save** to save the Catalog Lookup details and a confirmation message is displayed. The newly added Catalog lookup is listed in the Catalog Lookup Summary page.

The newly added Catalog Lookup is listed as a new source on the LHS of the Connector User interface in the Data Descriptor list. The Catalog Lookup Objects will appear along with the EDD objects in this list. Each Catalog Lookup Object is represented with an icon marked "CL" in dark blue color to distinguish it from the EDD objects.

## 16.2.2.2 Viewing a Catalog Lookup

**Note**

Users cannot modify or edit Catalog Lookup Objects.

To view a Catalog Lookup, Drag and drop the Lookup Object from the Data Descriptor list in the Connector canvas page and left click to view the details.

### 16.2.2.3 Search for Catalog Lookup

Use the search option in the Data Descriptor list from the Connector canvas page. Users can search for a Catalog Lookup using its Name.

For example, enter the Catalog Lookup keyword as Account Lookup in the search box. The search results show the list of all Catalog Lookups containing the text 'Account Lookup'.

### 16.2.2.4 Catalog Lookup Summary

The Catalog Lookup Summary page lists all the available lookup objects created for a Target entity.

To search for a catalog lookup object, follow these steps:

1. On the Home page, select the required Subledger Application.
2. Click the **Data Ingestion** link.
3. From the LHS menu, select **Catalog Lookup Summary**. The list of available lookup objects are displayed.
4. Search for a catalog lookup using its name and the corresponding details are displayed.

## 16.2.3 Data File Encryption

Data Encryption ensures secure handling of files during Data Ingestion (EDD). It functions as a stand-alone file encryption utility that enables both encryption and decryption of data files. This feature allows you to work with encrypted files while maintaining control over when encryption or decryption is applied.

Encryption is optional and remains disabled by default. It becomes available only after an Administrator configures a valid encryption key.

Encryption applies to the entire file, not to individual columns. Currently, the system uses one active encryption key for all encryption and decryption activities.

#### Limitations of File Encryption

- AAI currently supports only a single encryption key; support for multiple keys is not available at this time.
- Decryption of previously encrypted files is not supported after a key change (no backward decryption capability).
- Archive files must be pre-encrypted; encryption is not performed during the archiving process.
- Encryption keys must follow a strict Base64 format (KEY:IV), which may limit flexibility and ease of use.
- File encryption is not supported for out-of-the-box ingest connectors.

### 16.2.3.1 Configuring Administrator Key for Data File Encryption

The platform uses an encryption key to secure files during data processing. This key is set up and managed only by Admin users and is used for both encrypting outgoing files and decrypting incoming files. Encryption options are available only if an Admin has configured a valid key.

**Note**

Users with AFCSADMNGRP - Accounting Foundation Admin Group access can only add an encryption key.

1. On the AFCS Home page, click the **My Profile** icon and select **Administration**.
2. Click **File Encryption**.
3. Enter a key in the **Encryption Key** field.

**Note**

- The key must be in Base64-encoded `KEY:IV` format with a maximum character limit of 256.
- When a new key is configured, previously encrypted files cannot be decrypted using the old key.

4. Click **Save**.

## 16.2.3.2 External Data Descriptor - Encrypted Files

When working with an External Data Descriptor, you can specify whether the incoming data file is encrypted so that the system can process it correctly.

By default, encryption is turned **OFF**, and the system expects non encrypted files. If your incoming file is encrypted, you must enable the **Is data file(s) encrypted?** option in the **Data** tab. Once enabled, the system will automatically decrypt the file using the configured encryption key and then load the data.

If your data file is provided within an **archive (such as a ZIP file)**, ensure that the individual files are already encrypted before they are archived. The system does not encrypt or decrypt the archive itself.

For **Control files**, if they are provided separately from the data file, you can enable the **Is Reconciliation file encrypted?** option in the **Control** tab. This ensures the control file is decrypted before processing. However, if both data and control information are contained in the same file, this option will be disabled, and the encryption setting defined for the data file will apply to the entire file.

For more information, see [External Data Descriptor](#).

## 16.2.3.3 Troubleshooting Encryption Error

- **Encryption Errors:** Unable to encrypt the file. Please make sure the Encryption Key entered by Admin is valid.
- **Decryption Errors:** Unable to decrypt the file. Please make sure the Encryption Key entered by Admin is valid.
- **Invalid Key Format:** Invalid encryption key format. Please provide the key in Base64-encoded KEY:IV format.

## 16.3 Data Egress

This section describes the Data Connectors used in AFCS.

### 16.3.1 Connectors

Connectors allow mapping one or more External Data Descriptors with an Application Data Interface. You can configure the connectors for data exchange (inbound and outbound).

1. Navigate to Home page, and click **Ingest Connectors**.
2. Click **Add**. The **New Connector** window appears.

#### 16.3.1.1 Icons and Description

This section describes the tools AFCS provides to create connectors.

**Table 16-6 Icons and Description**













Icon	Description
	Click the Source button to view the list of all External Data Descriptors and Catalog Lookup objects created in the setup. Use the Search field to quickly locate the EDD/Catalog Lookup you are looking for. After locating the EDD/Catalog Lookup, you can drag the desired EDD/Catalog Lookup on to the canvas.
	Click the Target button to view the list of all Application Data Interfaces (ADIs). Use the <b>Applications</b> field to filter and the search icon to quickly locate the ADI you are looking for.
	The Connect component is used to map the source columns to target columns. Note: From AFCS 25D release, Mapping Component has been renamed as <b>Connect</b> in the User interface.
	The Join component is used to define a join between two entities. Double click this icon and provide the join condition information.
	The Filter component is used for define the filter of a given entity. Double click this icon and provide the filter expression information.

Table 16-6 (Cont.) Icons and Description

Icon	Description
	The Lookup component is used to define the lookup condition. Double click this icon and provide the lookup information.
	The Expression component is used to define defining the derived columns. Double click this icon to define an expression, which can be mapped to the target column.
	The Flattened Table To Hierarchy component is used to transform flattened hierarchy entities into parent-child hierarchy entities.
	The Transpose (Row to Column) component is used to transpose rows to columns for a given entity. Double click this icon to define the pivot data element and the new columns, which are transposed from multiple rows of the source entity.
	The Transpose (Column to row) component is used to transpose columns to rows for a given entity. Double click this icon to define the unpivot data element and new rows which are transposed from the columns of the source entity.
	The Aggregation component is used to define a group by and having a clause for aggregation. Double click this icon to define a group by and having a clause for aggregation.
	Click this button to remove all the nodes added to the canvas.
	The Reference Identifier Generator component is used to generate unique identifiers for AFCS dimensions even though source systems do not provide it.

## 16.3.2 Creating Connectors

Connectors allow you to map one or more External Data Descriptors with Application Data Interfaces. You can also map one or more ADIs with EDD using the extract type connector.

## 16.3.3 Ingesting Data into AFCS

To create a connector for ingesting data into AFCS, complete the following steps:

1. On the **Sub Ledger Applications** page, click the SLA for which you want to define a connector and click **Data Ingestion**.

The connectors which are defined are listed here.

2. From the LHS menu select **Connectors** if it is not already selected.
3. Click **Add**.

The **New Connector** window is displayed.

4. To define a connector, you must have a source with EDD/ Catalog Lookup Object and a target, which is ADI.
5. Click **Source** to view the list of EDDs defined in the default EDS of the ERP File Extracts and Catalog Lookups defined on the Target ADI.
6. Select the default EDS-ERP File Extracts file type EDD/ Catalog Lookup and drag it on to the Connector canvas.

For more information on defining a Catalog Lookup Object, see [Defining a Catalog Lookup Object](#).

7. Click **Target**.
8. Search for the ADI you are looking for.
9. Select the required ADI and drag it on to the Connector canvas and then link the input and output nodes.
10. To link the nodes, right click on a component and click **Link to** and select the component you want to link it with. You can also use your mouse to link the nodes. Point your mouse on the white circle of the input node and with your left-mouse button pressed, move the cursor to the white circle on the output node and release the mouse button.
11. At any given time, you can right-click a node to either link, delink, remove inlinks/outlinks, or delete a node.
12. To edit or view the properties, on the Connector window, click the Next button on the top of the page.
13. Under **Connector Details**, enter the name and description for the connector.
14. Under **Pre-Load Options**, select the truncate option to be defined in the target.
  - Select one of the available truncate options if you want to remove data from the table. Select No, if you do not wish to truncate the table before loading.

#### **Note**

For multi-target loads, the truncate type must be the same for all targets. However, truncate expression may vary.

- Select **Full Truncate** to fully truncate. Example: To truncate the entire table. Here no expression is required.
- Select **Selected Rows** to truncate based on a specified filter expression. Click the edit button next to **Specify filter expression** to define the expression. Example; If you want to remove some rows, use the **Selected Rows** option. Specify the filter condition for the rows to be deleted. Those rows are removed from the table before load.
  - Click **Edit** to filter the selected rows.
  - Select the required entity and click **Validate**. This validates the expression.

- Click **Ok** after the expressions are selected.
  - Select **Partial Truncate** to partially truncate based on the sourced records. To partially truncate, select **Executed As of Date** value from the drop down in the **Sourced records for** field for the data to be truncated based on the As of Date processed.
15. Under **Properties**, enter the value in the **Target Rejection Threshold** field. You can define the value in number or percentage of error records. For more details, see the [Using Target Rejection Threshold](#) section.
  16. Click **Save** or **Save As Draft**.

## 16.3.4 Filter

This section provides information about the Filter component.

1. Drag and drop the Filter component on the canvas to define a filter on an entity such as EDD (Insert Connector)/Catalog Lookup.
2. To position the component on the canvas, drag and move the component, or click the component and use arrow keys on the keyboard to move it around.
3. It accepts input only from an entity and can have only one output.
4. To have filters for multiple entities, drag and drop as many filters as the number of entities you want to filter, connect each filter to its respective entity, and then define their expressions. Example: To add a filter to three entities, add three filters on to the canvas.
5. At any given time, right-click the component and select the relevant options to either delink, remove inlinks or outlinks, or delete the component.
6. To define the filter expression, double-click filter component. The Filter Expression Window is displayed. The selected entities and parameters are displayed. Specify the required filter expression using columns and parameters. Click **Validate** to verify the correctness of the SQL Expression. Click **OK**.

### ① Note

Runtime parameters/expressions cannot be validated. For example:  
#DIH.MISDATE

7. You need not add the 'WHERE' clause for the filter.

### ① Note

- a. For file data loading, use the filter expression of the type **Number** along with single quotes. **For example:** N\_DRAWN\_AMOUNT = '40000'.
- b. For the **Date** field, see To\_CHAR function for comparison.
- c. Parameters can also be used in the filter expression. The date format must be a valid SQL Date Format.

### For Example:

```
[EDD_GL_DATA].[EXTRACTION_DATE] = TO_DATE (#DIHDEV.MIS_DATE,'dd-MM-yyyy')
```

## 16.3.5 Join

This section provides information about the Join component.

1. Drag and drop the Join component on the canvas to link multiple entities such as EDDs (Insert Connector)/ Catalog Lookup.
2. To position the component on the canvas, drag and move the component, or click the component and use arrow keys on the keyboard to move it around.
3. Join accepts input from two entities.
4. To join more than two entities, drag another Join component. Link the output of the first join to the input of the second join and then connect the other entities. You can repeat this for multiple entities. Select the source entity and click **Ok**.
5. At any given time, right-click the component and select the relevant options to either delink, remove inlinks or outlinks, or delete the component.
6. Double-click the Join component to define a join condition. The selected entities are displayed on the left and right tabs.
7. You can drag and reorder the left and right tab to choose the right/left entity in a join condition.
8. To join entities, the select a column from the left, select a column from the right tab and click = (Add Join). This displays the joined entities. You can join multiple entities.
9. To remove two joined conditions, select the two columns from the left and right tabs, and click Remove Join. The joined condition is removed from the list.
10. Click **Reset** to reset all the joined conditions.
11. Click **Ok**.

### Note

This creates an inner join between the connected EDDs/Catalog Lookup objects.

## 16.3.6 Lookup

This section provides information about the Lookup component.

1. Drag and drop the Lookup component on the canvas to lookup values from an entity.
2. To position the component on the canvas, drag and move the component, or click the component and use arrow keys on the keyboard to move it around.
3. The lookup component accepts input from two entities. One from the Value Entity and the other from the Lookup Entity.
4. At any given time, right-click the component and select the relevant options to either delink, remove inlinks or outlinks, or delete the component.
5. Double-click the lookup component to define a lookup condition. In the Lookup window, you will see the connected entities on the left and right tabs.
6. You can drag the lookup entities on the right and left to reorder them.
7. To specify the lookup condition, the select a data element from the left, select a a data element from the right and click = (Add Join). The lookup condition is displayed at the

bottom of the window. Do this for an many entities on the left and right tabs you want to define.

8. To remove a lookup condition, select data elements from left and right entities and click **Remove Join**.
9. Click **Reset** to reset the lookup condition.
10. Click **Ok**.

#### Note

This creates a left outer join between the connected entities.

## 16.3.7 Aggregation

This section provides information about the Aggregation component.

1. Drag and drop the Aggregation component on the canvas to define an aggregation on an EDD or a Catalog Lookup Object.
2. To position the component on the canvas, drag and move the component, or click the component and use arrow keys on the keyboard to move it around.
3. Aggregation component accepts input from an EDD or a Catalog Lookup and it can have only one output.
4. If you have multiple EDDs/ catalog Lookup to be aggregated then you must select as many number of aggregation components, connect each to the respective EDD/ Catalog Lookup, and then define their group by having clauses. Example: To add aggregation to three EDDs or Catalog Lookups, drag three aggregation components on to the canvas and link them to their respective EDDs or Catalog Lookups.
5. At any given time, right-click the component and select the relevant options to either delink, remove inlinks or outlinks, or delete the component.
6. Double-click the Aggregation component to define an aggregation condition. In the Aggregation Window, you will see the selected EDD or Catalog Lookup under the Entities tab. Double click the entities, functions, and operators to build your expression in the Group By field. Repeat this step to build your clause in the Having field.
7. Click **Validate** to verify the correctness of the SQL Expression.
8. Click **Ok**.
9. Click **Reset** to reset all the aggregation conditions and begin afresh.

## 16.3.8 Reference Identifier Generator

This section provides information about the Reference Identifier Generator component. Use this component to generate a unique sequence identifier for the selected attribute.

1. Drag and drop the **Reference Identifier Generator** component on the canvas.
2. To position the component on the canvas, drag and move the component, or click the component and use arrow keys on the keyboard to move it around.
3. At any given time, right-click the component and select the relevant options to either delink, remove inlinks or outlinks, or delete the component.
4. Double-click the component to define an reference identifier generator condition.

5. Provide a **Name**.
6. Specify the source attributes with unique values by selecting the relevant value from the drop-down list.
7. Specify **Identifier Type** as Numeric or Varchar.
8. Select the **Target Attribute**.
9. Click **OK**.

### 16.3.9 Transpose (Rows to Columns)

This section provides information about the Transpose (Rows to Columns) component.

1. Drag and drop the Transpose (Rows to Columns) component on to the canvas.
2. To position the component on the canvas, drag and move the component, or click the component and use arrow keys on the keyboard to move it around.
3. The Transpose (Rows to Columns) component accepts input only from an EDD and can have only one output.
4. If you have multiple EDDs selected, and you want to have a Transpose (Rows to Columns) component for more than one EDD, then you must select as many number of Transpose (Rows to Columns) components, connect each to its respective EDD, and then define their expressions.
5. At any given time, right-click the component and select the relevant options to either delink, remove inlinks or outlinks, or delete the component.
6. Double-click the component to transpose the entity rows into columns. Specify the pivot data element to transpose rows into columns.
7. Specify the Column name - matching row value – Expression combination. You must have a minimum of two combinations.
8. Click **Review** to review the transformation. A the sample of the transformed data is displayed.
9. Click **Ok**.

### 16.3.10 Transpose (Columns to Rows)

This section provides information about the Transpose (Columns to Rows) component.

1. Drag and drop the Transpose (Columns to Rows) component on the canvas to define a Transpose (Columns to Rows) Component on an EDD.
2. To position the component on the canvas, drag and move the component, or click the component and use arrow keys on the keyboard to move it around.
3. The Transpose (Columns to Rows) component accepts input only from an EDD and can have only one output.
4. If you have multiple EDDs selected, and you want to have a Transpose (Columns to Rows) component for more than one EDD, then you must select as many number of Transpose (Columns to Rows) components, connect each to its respective EDD, and then define their expressions.
5. At any given time, right-click the component and select the relevant options to either delink, remove inlinks or outlinks, or delete the component.
6. Double-click the component to transpose the entity columns into rows. Specify the **Unpivot Data Elements** to transpose columns into rows.

7. Specify the **Header Column Name** and **Value Column Name**.
8. Specify the column value (**Header column**) and expression pair (**Value column**) for each transposed row. You must have a minimum of two pairs.
9. After specifying the **Unpivot Data Elements**, click **Auto Transpose**. This will transpose columns into rows based on the unpivot data elements selected.
10. Click **Review** to view the transformed data.
11. Click **Ok**.

### 16.3.11 Derived Column

This section provides information about the Derived Column component.

1. Drag and drop **Derived Column** component on the canvas.
2. To position the component on the canvas, drag and move the component, or click the component and use arrow keys on the keyboard to move it around.
3. Connect the output of the **Derived Column** component to the **Mapping** component.
4. At any given time, right-click the component and select the relevant options to either delink, remove inlinks or outlinks, or delete the component.
5. Double-click the **Derived Column** component and click **Add** to define a new derived column.
6. On the right pane, under **Entities**, double-click to select the entities which you want to use to build the expression. The selected entities appear in the Expression field at the bottom. Modify the expression based on your needs. Provide the Name for the derived column.
7. Click **Validate** to verify the correctness of the SQL Expression.
8. Click **Apply**. The saved details appear as a list on the left pane.
9. Click the **Edit** button to modify the name and expression of the required Derived Column.
10. Repeat the steps to create as many Derived Columns as you require.
11. Click **Ok**.

### 16.3.12 Connect

This section provides information about the Connect component.

1. By default, the Connect component is available in the User Interface. Connect the inputs and outputs for the **Connect** component before specifying the mapping details.
2. To position the component on the canvas, drag and move the component, or click the component and use arrow keys on the keyboard to move it around.
3. Double-click the **Connect** component on the canvas. The EDDs, ADIs, and their respective data/derived data elements are displayed in the Mapping window.
4. Filter the source attributes by selecting an option from the drop-down list. Click a data element under **Source**.
5. Filter the target attributes by selecting an option from the drop-down list. Click a data element under **Target** and then click the **Map** button. The column mappings are displayed.
6. Click the **Map** button. The mapped items are displayed on the right column mappings are displayed.

7. Repeat the steps to map as many source-target pairs as required. Note that you can use the filter icons for the **Source** and **Target** lists to filter unmapped, mandatory, or those items that are valid for the application.
8. The following validations are performed for the mapping:
  - a. Data type validation
  - b. Data length validation
  - c. Data precision validation
9. The result of the validation for each mapping is indicated as **Remarks** next to each mapping.
10. At any given time, you can select the **Unmap** button to unmap the source and target.
11. Click **Auto Map** to auto map a source and target.

**Note**

Auto-mapping is done by matching the logical/physical column name of both the source and target.

12. Hover your mouse over a data element under **Target** column to see detailed information which includes the description, length, and scale.
13. Use the search icons to search for source or target data elements.
14. Click the **Delete All** icon to delete all the mappings. You can also delete individual mappings by selecting the cross symbol next to the column mapping.
15. Click the **Import to Excel** icon to import a mapping Excel sheet.
16. Click the **Export to Excel** icon to export the mapping information in an Excel format.
17. Use the search field to search for mappings. You can search for an item based on the **Source Column Name**, **Target Column Name**, **Source Entity**, **Target Entity**, or **Remarks**.

### 16.3.13 Flattened Table to Hierarchy

This section provides information about the Flattened Table to Hierarchy component.

1. Drag and drop the **PC Hierarchy** component on the canvas.
2. To position the component on the canvas, drag and move the component, or click the component and use arrow keys on the keyboard to move it around.
3. Connect an EDD / Source Filter to the input of the **Flattened Table to Hierarchy** component.
4. Connect the output of the **Flattened table to Hierarchy** component to the **Join / Lookup / Mapping** component.
5. At any given time, right-click the component and select the relevant options to either delink, remove inlinks or outlinks, or delete the component.
6. To specify the details, double-click the **Flattened table to Hierarchy** component.  
The **Flattened Table to Hierarchy** window is displayed.
7. Choose the **Hierarchy Type** as **Balanced**, **Ragged**, or **Skipped**. Click **Help** icon to view the details and understand how the hierarchies are defined.

8. Specify the **Number of levels** in the hierarchy.
9. Specify the **Parent Node Column Name** and **Child Node Column Name** .
10. Select the **Key Elements** from the drop-down list. You can select multiple Key Elements for an hierarchy.
11. Select all the node level details from the respective drop-down lists.
12. Click **Review** to view the transformation changes.
13. Click **Ok**.

## 16.3.14 Hierarchy Data Flattening

The hierarchy flattening component in the Data ingestion definition allows you to use input files in a parent-child hierarchy structure and convert them into a flattened dataset during the ingestion process without any additional configuration outside the system. The application supports balanced, unbalanced, and skipped hierarchies for flattening.

This section provides information about the Hierarchy to Flattened Table component.

1. Drag and drop the **Hierarchy to Flattened Table** component on the canvas.
2. To position the component on the canvas, drag and move the component, or click the component and use arrow keys on the keyboard to move it around.
3. Connect an EDD / Source Filter to the input of the **Hierarchy to Flattened Table** component.
4. Connect the output of the **Hierarchy to Flattened Table** component to the **Join / Lookup / Mapping** component.
5. At any given time, right-click the component and select the relevant options to either delink, remove inlinks or outlinks, or delete the component.
6. To specify the details, double-click the **Hierarchy to Flattened Table** component.  
The **Hierarchy to Flattened Table** window is displayed.
7. Select **Key Elements** from the drop-down list. You can select multiple Key Elements for a hierarchy. Parent or Child attributes cannot be selected as Key Elements.
8. Specify the maximum **Number of levels** in the hierarchy. By default, the number of levels is set to 3.
9. Select the **Parent Identifier**, **Parent Code**, and **Parent Name**.
10. Select the **Child Identifier**, **Child Code**, and **Child Name**.
11. Click **Review** to view the transformation changes.
12. Click **Ok**.

## 16.3.15 Specifying Alias in Connector

Alias refers to an assumed name or pseudonym assigned to an EDD as you define connectors, much like table aliases used in SQL statements. Aliases allow an EDD to be referred in multiple joins, lookups, or both, within the same connector definition, each in a distinct context.

Aliases are automatically initiated by Data Integration Hub (DIH) as and when required while defining connectors.

The following scenario explains the mechanism:

1. Drag and drop an EDD more than once, for use in separate joins or looks-up, on the **New Connector** canvas. DIH initiates the specification of an alias by displaying the **Specify Alias** dialog box.
2. Enter a name of your choice under **Alias Name** and click **Ok**.  
Note that the Alias Names must be unique within a connector.

### 16.3.16 Modifying and Viewing a Connector

To edit or view a connector, complete the following steps:

1. To edit or view a connector, you can select the required connector from the Connector Summary.
2. The details of the selected connector are displayed. You can modify or view the details.
3. Modify the connector's details as required. Connector Name cannot be edited.
4. Click **Save**.
5. To make changes to a published connector, click **Unpublish**. This clears the ODI metadata that has been created during publishing. Update the required changes and then click **Publish**. The updated changes are synced in ODI.

### 16.3.17 Copying a Connector

To copy an existing connector, complete the following steps:

1. Click the Copy button of the required connector. Depending on the view in which the original connector was created, the copied connector too will have the same view.
2. Enter the **Name** and **Description**.
3. Click **Save**. The details are saved with a new connector name. The existing connector remains unmodified.

### 16.3.18 Deleting a Connector

To delete an existing connector, complete the following steps:

1. Click the **Delete** button of the required connector.
2. Acknowledge the confirmation message.

### 16.3.19 Search and Filter

Use the search and filter options in the Connector Summary page to find the required connector. Enter the nearest matching keyword to search, and filter the results. You can search for a connector with either the name, description, or status of the connector.

You can sort the list by connector name or modified date in ascending or descending order.

### 16.3.20 Parameters in Connector

Parameters are used when defining the EDD to ADI mapping. While mapping the ADI to an EDD, the fields or columns within the ADI must be mapped to the fields in the EDD. If there are no corresponding extracts in EDD, parameters can be used to identify the default values for certain ADI elements. Parameters can also be used while defining derived columns during mapping.

For example, if you want to use the Runtime MIS Date as the parameter, you must first convert it to date. The following is the expression:

```
To_char(to_date(#DIHDEV.MIS_DATE,'dd-MON-YYYY'),'MM')
```

**Note**

Runtime batch MIS date is in String format. You must convert it to a valid SQL date format.

## 16.3.21 Using Target Rejection Threshold

Target Rejection Threshold is a value defined for the number or percentage of records with errors that are allowed before the execution is configured to fail when you move records from the source database to the target database. It can be entered as an absolute value or as a percentage in the **Connector Properties** window.

AFCS creates an error table by duplicating the target table name and appending it with **\_ERR** during the execution process. The erroneous records are logged into the error table and valid records are moved to the relevant table in the target. The errors can be of the types notional, public key, or data. For example, if the target table name is **STG\_CASA**, then the error table name is created as **STG\_CASA\_ERR**. The objective is to log only a required number of errors and then correct them in the source table. After correcting the errors, rerun the execution. In the process, you can iteratively collect the errors and correct them, making the task of correcting the errors in the source table much simpler.

You can also move records from file table to the target database and the structure of the table remains same as file table added with five additional columns. For example, if the file table name is **EDD12\_THRESHOLD\_VOLUMETEST**, then the error table name is created as **EDD12\_THRESHOLD\_VOLUMETEST\_ERR**.

Let us understand this process with the help of the following example.

1. Enter 10 in the Target Rejection Threshold field.

**Note**

- a. To specify the value as 10 percent of the records in the execution, enter 10%.
- b. If you leave the field blank or enter 0, AFCS reads the threshold as 0 and the execution fails when an error is encountered.  
On execution of the process, AFCS permits up to 10 records with errors to process to the target table and any number of valid records. If the number exceeds 10, the execution process fails and stops. The erroneous records are available in the target table name appended with **\_ERR**.

2. In the SLA home page, under any SLA, click **Data Ingestion** and select **View Data**. This will display [Data Visualization window](#) where you can search for the target table name appended with **\_ERR**.
3. Check the details in the error table.  
For information on how to read the error table, see the [Reading the Error Table](#) section.
4. After checking the error table details, navigate to the source table and troubleshoot the errors.

5. After correcting the errors, rerun the execution.
6. Repeat the process iteratively and correct the errors.

### 16.3.21.1 Reading the Error Table

AFCS creates the error table in the data service execution layer/schema to store records with errors. The structure of the error table is similar to the target table but with five additional columns. You can refer to the following column for executions:

- `ORA_ERR_NUMBER$` - The error number.
- `ORA_ERR_MESG$` - The ORA error message with the description of the error.
- `ORA_ERR_ROWID$` - The row ID of the error.
- `ORA_ERR_OPTYP$` - The operation type.
- `ORA_ERR_TAG$` - This column stores the Execution ID. You can use this column to filter and view error records for a specific execution.

## 16.3.22 Executing Connectors

Use the Process Modelling Framework to execute a DIH connector.

### 16.3.22.1 Executing Connector Using Process Modelling Framework

Process Modelling Framework (PMF) is a design and execution framework that enables process pipeline developers to implement the various pipelines modeled by business analysts. Process pipeline developers use the framework to orchestrate business, run pipelines within AFCS, and to design the artifacts that participate in the pipelines, to complete their implementation. For more details, see the Managing Process section.

To add a connector task in the PMF pipeline, complete the following steps:

1. On the Home page, click the **Process Orchestration** link on the left.
2. Search for and open the process pipeline to which you want to add a connector task.
3. Click to expand the left menu. Drag and drop **Connector** under **Widget** to the canvas.
4. Double-click the **Connector** and specify the **Activity Name** and **Activity Description**.
5. Under the Dynamic Parameters for Connectors:
  - Select the required connector.
  - Enter the runtime **Variables**. If the connector contains any runtime parameter, see the section: Specifying Runtime Parameters, for more details.
6. Enter all details and click **Save**.

### 16.3.22.2 Specifying Runtime Parameters

Note the following points regarding runtime parameters:

- If the connector contains runtime parameters, they can be set in the Variables input field of the connector's definition window. Example: `FILE_DATE=31-Jan-2022`.
- In this example, the date format appended to `MISDATE` has to conform to the Simple Date Format. If no date format is specified, the default date format used is `yyyyMMdd`.
- If variables are used as a part of connector mappings or filter expressions, specify them as given in this example. Example: `FILE_DATE=$MISDATE:dd-MMM-yyyy`.

## 16.4 Quality

For information about the data quality checks (DQ Checks) and the out-of-the-box pipelines, see the Data Quality Checks section in the *OFS AFCS Data Catalog User Guide*.

## 16.5 Dimensions

For information about the slowly changing dimensions (SCDs) and executing the out-of-the-box SCDs in AFCS, see the Slowly Changing Dimensions section in the *OFS AFCS Data Catalog User Guide*.

## 16.6 Hierarchy Management

AFCS supports the definition of hierarchies based on dimension attributes and their use in the reporting layer. Users will be able to specify display names for hierarchies in the user interface which will enable alternate hierarchies in the BI Catalog. This will allow users to define custom reports in the 'Balance Computation' Subject Area.

To define a name for Hierarchy, complete the following steps:

1. On the AFCS Home page, click the **My Profile** icon and select **Administration**.
2. Click **Hierarchy Management**.
3. Select the hierarchy table from the **Choose Dimension** drop-down for which you want to define a name and click on the hierarchy.

### Note

When you expand the custom hierarchy, the code and name is displayed.

The **Definition** section is displayed.

4. Enter the name and description for the hierarchy and click **Save**.

### Note

[Reference Identity Generator](#) may be used to generate/assign unique numerical identifiers to dimension members and referred in maintaining related hierarchy information (parent-child data)."

The Hierarchy name is saved and the same will be displayed in the Reports.

### Note

Following are the number of custom hierarchies for OOB tables supported in the current release.

- Branch Code - 1
- General Ledger Account Code - 5

- Legal Entity Code - 1
- Organization Unit Code - 4
- Product Code - 1
- Acquisition Channel Code - 1
- Business Unit Code - 1
- Intercompany Identifier - 1
- Location Code - 1
- Project Code -1

## 16.7 Reporting Parent-Child Data Population

For a parent-child data population, there are out-of-the box hierarchies that are used in analytics layer for which the data must be available. The Analytics layer uses this hierarchical dimension data for building the seeded hierarchies in the reporting layer. You must use the PMF (Reporting Parent-Child) to load this hierarchical data for the below mentioned hierarchies. This needs to be performed everytime there is a change in the dimension hierarchy for this code. The reporting layer always retains the latest structure of hierarchy that is available.

Login to the application and execute the process **Reporting Parent Child Relation Data Population**. Select **Dimension Hierarchy Entity** (Single/Multiple) and select the **DataSource** value as NA.

### Note

Prior to viewing the Dashboard reports, you must run the **Reporting Parent Child Relation Data Population** PMF pipeline.

Following are the list of Out-of-the-box hierarchies that are supported:

**Table 16-7 Number of Out-of-the-Box Hierarchies**

Hierarchy Names	Number of Hierarchy Codes
Branch Code	1
Business Unit Code	1
Acquisition Channel Code	1
General Ledger Account Code	5
Legal Entity Code	1
Location Code	1
Organization Unit Code	4
Product Code	1
Project Code	1
Intercompany Identifier	1

## 16.8 Data Maintenance Interface

**Data Maintenance Interface (DMI)** helps to design a Data Form in a user-specified format. Further, it allows performing data entry-type actions using the Designed Form.

The **Form Builder** within the **Data Management Interface (DMI)** provides users with the capability to design and configure custom forms tailored to data-related activities. These forms serve two primary purposes:

- **Data Entry:** To enable manual input of data into structured formats.
- **Excel Upload:** To allow users to upload datasets in bulk using Excel files.

The **Data Management Interface (DMI)** facilitates a structured workflow for creating, authorizing, and using forms to manage data input. The process consists of the following key stages:

- **Form Creation:** A user initiates the process by creating a form using the **Data Entry** or **Excel Upload**. This form includes configurations such as entities, attributes.
- **Form Authorization:** Once the form is created, it must be reviewed and authorized by a user with **authorization privileges**. This step ensures the form complies with data standards and access controls.
- **Form Activation:** Upon approval, the form is marked as **Authorized**.
- **Data Entry:** Users can now **enter data** using the authorized forms. The inputted data is then captured and stored in the **database**.

### **Note**

Authorized Forms are the central point of control, ensuring only approved data structures are used. The process enforces data governance by involving validation and authorization steps before data input. Supports both manual entry and bulk upload depending on the form type.

**Figure 16-1 DMI Process Flowchart**

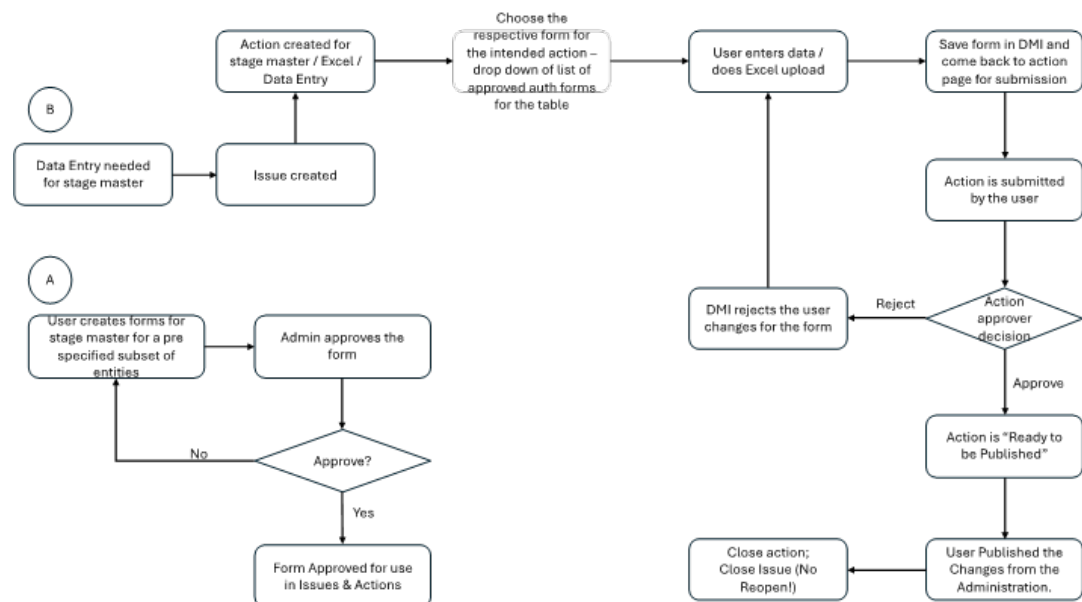

Refer to the [User Roles and Privileges](#) for details on user roles and their descriptions, which define the permissions required to perform the actions described above.

## 16.8.1 Configuring Data Maintenance Forms

You can create forms from the Form Designer View. The forms in the application are created with details configured for data maintenance and require authorization for use after creation. You can also edit, view, and delete forms, from the Forms Definitions Summary, based on the assigned roles and privileges. For more information, refer To access the Data Maintenance Interface (DMI):

1. Login to your Oracle Cloud account, with the required credentials to access DMI.
2. Select the **Profile** button and click on **Data Maintenance Interface** to display the **Forms Definition - Summary** page. This section enables users to create and manage custom forms for data operations. It provides a summary of all existing DMI forms and an option to add new ones.

### Note

The navigation steps vary for different applications. Refer to the respective application documentation for accessing Data Maintenance Interface.

3. The following details are included the Summary page.

- **Name** - The unique name of the Form Definition
- **Description** - The Form Definition description.
- **Type** - The form definition type:
  - **Excel Upload** – creates form based on uploaded Excel Sheet.

### Note

Make sure the Excel files are saved in the Microsoft Office 2016 Standard version. Excel files saved in Office 365 version cause compatibility issues.

- **Data Exporter** – creates form based on an entity table.
- **Data Entry** – creates the form based on the entities, attributes and rulesets provided by the user.
- **Status** - The processing status of the form definition. The various processing statuses are:
  - **Draft** – when the form is under development and is yet to be submitted for approval.
  - **Pending Approval** – When the approval is pending.
  - **Approved** – When the form definition is approved.
- **Created By** - The Username of the logged in User who created the form.
- **Actions** - View, copy or edit or amend a form definition.
- **Info** - The form definition details including:
  - Created Date
  - Last Modified By

- Authorizer
- Authorizer comments

Use **Search** to quickly access the required forms or check the Forms tile to view a list of existing forms. To search for a specific Form Definition, input search terms in the **Form Name** or **Description** field, or use a combination of both, and click **Search**. Click **Cancel** to clear the search criteria and view all form records.

Sort the Form Definition based on **Name**, **Description**, and **Created By** fields. You can also sort the page in ascending/descending order.

To filter and view Form definitions with a specific processing status, click the respective status name at the top of the page.

## 16.8.2 Creating New Forms

Form creation involves selecting entities, displaying columns with attributes on the form, and if required, selecting authorization of data. Security settings provide for the creation of specific-user access for the forms and authorization.

1. In the **Data Maintenance Interface** page, click **Add**, to access the **Create Forms Definition** page.

Opens the **Designer - Configure** screen.

2. Enter the following details.

- **Excel Upload** – creates form based on uploaded Excel sheet. For bulk uploads via spreadsheet.
- **Data Entry** – creates the form based on the entities, attributes and rulesets provided by the user. For manual data input.
- **Code**: Auto-generated.
- **Name**: Enter the form name.
- **Description**: Provide a short explanation of the form's purpose.

### Note

For more information about creating various form definitions:

- [Configuring Data Entry](#)
- [Configuring Excel Upload](#)

### 16.8.2.1 Configuring Data Entry

Use the Data Entry option to create a Forms Definition and select the table and attributes that you want to modify.

You can enter the values for the table records in the approved Forms Definition from Data Entry, after the new Forms Definition is approved from the Forms Definition Summary Page.

To configure the Data Entry definition, enter the details in the following sequence.

- Details
- Entities
- Attributes

- Ruleset
- User Security
- 1. Select **Data Entry** in Create New Form Definition page and enter the required details.
- 2. Enter the following details:
  - **Code** - Unique form code. This value is auto-generated.
  - **Name** - Enter the name. You can enter between 3 to 100 characters. Only alphabets, numbers, spaces, and underscores are allowed.
  - **Description** - Enter the form description. You can enter between 3 to 100 characters. Only alphabets, numbers, spaces, and underscores are allowed.
- 3. Click **Continue** to access the **Entities** tab or **Save** to store as draft.
- 4. Once the form is updated, click **Submit** if you want to submit the Forms Definition for manual/auto approval.

### 16.8.2.1.1 Entities

In the Entities tab, you can associate an entity with the form. An entity typically represents a data object or database table where the data entered through the form will be stored.

1. In the Entity search box, enter an entity name and select from a list of predefined entities. The key icon signifies that the entity is a primary reference for data mapping.
2. Click **Continue**, to proceed with the **Attributes** tab.

### 16.8.2.1.2 Attribute

This step allows users to define **which data attributes** (fields) from the selected entity will be included in the form. These attributes form the actual input fields visible to the end-user.

1. Select the **Filter** from the existing filters in the drop-down list or click **Filter** to define a new one for the form definition. The use of Filters is optional.

**Filter Condition:** Enables conditional filtering of entity attributes to display only relevant fields.

- Click the **filter icon** to open the **Expression Builder**.

**Filter Condition Builder (Pop-up):** This builder helps you create logic to filter attributes based on values.

- **Select Columns:** Pick an attribute to filter on.
- **Condition:** Choose a logical operator (e.g., equals, contains).
- **Filter Value:** Define the specific value to match.
- Use the **Validate** button to test your expression.
- Click **Apply** to activate the filter and return to the attributes list.

#### Note

If no columns are available, it means no entity was selected or the entity has no attributes mapped.

**Table 16-8 Attribute Grid Columns**

Field	Description
Entity Name	The name of the associated entity.
Source Attribute Name	The actual field name from the entity.
Participate in Data Security	Marks if the attribute should be part of access control logic.

- Click the drop-down arrow corresponding to the table in the **Entity Name**, to view the attributes in the entity table.
- Select the attributes for which you want to modify the data from the **Attribute Name**.
- Once attributes are selected, click **Continue** to proceed to Ruleset configuration, where form logic and validations can be defined.

### 16.8.2.1.2.1 Creating Data Filters for New Form Definitions

Filters help to view and export specific set of data from data exporter forms.

Complete the following steps if you want to add filters to the Forms Definition:

- Click on **Launch Filter Condition**, to access the Filter Condition pane.
- Enter/ select the following details.
  - Column** - Select the column from the applying the filter.
  - Condition** - Select one of the following filter conditions, to filter the column data.
    - Comparison** - '=', '!=', '< >', '>', '<', '>=', '<=', 'IN', 'NOT IN', 'ANY', 'BETWEEN', 'LIKE', 'IS NULL', and 'IS NOT NULL'.
  - Filter Value** - Select/enter the filter value.

#### Note

For Language Placeholder the default locale language is displayed and cannot be modified.

- Click **Add** to add a new Filter expression. You can add multiple Filter expressions to the same filter.

The filter is added to the list of filters.

Mouse-over the place holder filter, to view more details about the filter.
- Click **Validate** to verify the filter condition is valid.

A confirmation is message is displayed, if the filter is valid.
- Click **Apply**, to add the new filter to the filter condition.
- Click **Reset**, to clear all the filter expressions and create a new expression.
- Click **Delete** to delete an existing filter expression.
- Click **Edit** to modify a filter expression. After editing the expression, click **Validate**, to verify if the condition is valid. If user wants to update any filter condition, the user can select the existing condition and then change the condition or filter value and click on Validate to verify if the condition is valid.
- Click **Apply** to add the filter expression to the form definition.

## 16.8.2.2 Configuring Excel Upload

Excel Upload Definition Type creates new forms based on the uploaded Excel file that has column names as per the table in the application data source.

While creating forms using Excel Upload, you can also modify the mapping for the attributes. After the new form is approved from the Forms Definition Summary Page, users with the necessary role and permission can perform Data Entry for the records updated by the Excel file.

### Note

Make sure the Excel files are saved in the Microsoft Office 2016 Standard version. Excel files saved in Office 365 version cause compatibility issues.

To create forms using Excel Upload:

1. Select Excel Upload in the Create Form Definition page and add the following details.
  - **Code** - The unique Form code. This value is auto-generated.
  - **Name** - The Form Name. You can enter between 3 to 100 characters. Only alphabets, numbers, spaces, and underscores are allowed.
  - **Description** - The Form Definition description. You can enter between 3 to 100 characters. Only alphabets, numbers, spaces, and underscores are allowed.
  - **Auto Map Entities** - Enable this option to auto map the attributes in the Excel file with the attributes in the Entity Table.

### Note

Auto Map attributes feature does not always map all attributes between the user defined excel and the entities. In such a case where Auto Mapping fails, the user should manually map such attributes which were not auto mapped.

At any point of time during the form creation, click **Save** to add the new form to the Form Summary. The form is saved in the **Draft** format. Click **Actions** and select **Edit**, to update the form definition.

2. Click **Continue** to access the **File Upload** tab.

### 16.8.2.2.1 File Upload

Upload an Excel file that contains the data you want to ingest into the system. This step defines the upload template and allows you to add the actual file.

1. In the **File Upload** tab, enter the following details.

**Table 16-9 File Upload**

Field	Description
Name / Code / Description	Displays the template's predefined name, system-generated code, and description.

**Table 16-9 (Cont.) File Upload**

Field	Description
Template Name	A user-defined name for the upload template (e.g., "Q3_2025_Profit_Upload").
Description	Optional field to describe the file/template content.
Drag and Drop Area	Upload your Excel file: Click to browse Or drag-and-drop the file directly

The excel file is uploaded and a confirmation box is displayed, and the **Mapped Entities Tab** is displayed.

2. After the **File Upload**, click **Continue** to access the **Mapped Entities** tab.

### 16.8.2.2.2 Mapped Entities

This step links the uploaded Excel data to a specific business entity (like a data table or object) where the records will be stored or processed.

1. In the **Mapped Entities** tab, select the **Primary Entity** name of the table that needs to be modified.

**Table 16-10 Mapped Entities**

Field	Description
Entity Name	Use the search bar to find and select the target entity to map your Excel data to. This is usually a predefined structure like a database table, business object, or form entity.

2. Click the search icon or begin typing the entity name.
3. Select the appropriate entity from the dropdown list. Only one entity can be mapped per upload configuration.
4. Click **Continue**, to proceed with the **Mapped Attributes** tab.

### 16.8.2.2.3 Mapped Attributes

In this step, you map the columns from your uploaded Excel file to the target entity's attributes (fields). This ensures that data from the Excel file is correctly inserted into the system.

1. Click the grid icon on the left to begin mapping attributes.  
A list of entity attributes and corresponding Excel columns will appear.
2. Click the required mapping in the **Override Mapping Column** and enter the required attribute name if you want to change the default mapping.
3. Click **Continue** to proceed to the **User Security** tab.

### 16.8.2.2.4 User Security – Map Users / Groups

This section allows administrators to **assign access permissions** to specific users or user groups for managing data entry operations. Mapping users with proper authorization ensures data security and role-based access control.

- Click **User Security** to select the user or user groups who can perform data entry to maintain the data in the table.

**Table 16-11 User Security**

Field	Description
Search Bar	Used to find users or user groups by name.
Mapped Users	Displays the list of users or groups currently associated with the configuration. It lists available <b>groups</b> such as: <ul style="list-style-type: none"> <li>• Application Admin of Data Foundation For Banking</li> <li>• Data Maintenance Admin Group</li> <li>• FRC Data Analyst</li> <li>• FRC Data Catalog Administrator</li> </ul>
Add / Edit	Allows administrators to assign or modify users/groups and define their roles.
Delete	Removes selected users/groups from the configuration.
Authorize	Marks the configuration as authorized, which is often a prerequisite for applying changes.
Duration From / To	Defines the validity period during which the user/group will have access.

**Note**

Only authorized users/groups can interact with data based on the mapping. Unmapped users will be restricted.

For more information refer to [Approving and Rejecting New Form Definitions](#). After approval/auto approval, the form is added to the Form Definition Summary.

#### 16.8.2.2.4.1 Enabling User Security for New Form Definitions

The User Security option helps you to select the users/user groups who can add, edit, delete and/or authorize forms.

To enable user security:

- Select the required user group or user to assign permissions from the **Map Users / Groups**, to complete the user security configuration.

When you select the user group or user, the permissions for each approved Forms Definition are displayed. These permissions are the actions that the selected user group or user can perform while performing Data Entry.

**Table 16-12 Permissions in the Map Users / Groups Pane**

Option	Description
<b>Add /Edit</b>	Add or modify records in an approved Forms Definition

**Table 16-12 (Cont.) Permissions in the Map Users / Groups Pane**

Option	Description
<b>Delete</b>	<p>Deletion of all intermediate work (draft / awaiting records) of a form</p> <ol style="list-style-type: none"> <li>1. While closing the action associated to the form.</li> <li>2. While picking another form in an action which already has a form associated to it. All the intermediate work is deleted / cleaned up from the previous form before opening the new form.</li> </ol>
<b>Authorize</b>	<p>Authorize the records, Return the Action and Publish action in which the form is present.</p>
	<div style="border: 1px solid #ccc; border-radius: 10px; padding: 10px; margin: 10px 0;"> <p><b>Note</b></p> <p>A user who submits the form cannot approve or reject the same form.</p> </div>
<b>Duration From</b>	<p>Optional. Select the start date for which the permissions are available to the user or user group.</p>
<b>Duration To</b>	<p>Optional. Select the end date for which the permissions are available to the user or user group.</p>

**Note**

If you select a user group for User Security, you can view the users mapped to that group by clicking the **Users** icon.

### 16.8.2.2.5 Data Preview

This final step lets users **preview the data extracted** from the uploaded Excel file **before final submission**. It helps verify if data has been correctly mapped, cleaned, and is ready for upload into the system.

1. Click **Data Preview** to preview the form data.
2. Click **Save** if you want to save the forms definition in draft format. The form is added to the **Form Summary** with **Draft** status.
3. Click **Submit** when Forms Definition is ready for approval. Post approval, the form will be available in the Data Entry Action in Issues and Actions. For more information refer to [Approving and Rejecting New Form Definitions](#). After approval, the form is added to the Form Definition Summary.

### 16.8.2.3 Approving and Rejecting New Form Definitions

You can validate and approve the new Forms Definition if you have the required role assigned to you.

If the configuration in the Forms Definition is incorrect, you can reject the Forms Definition. The rejected Forms Definition changes into Draft status. You can then request the required user to edit the Forms Definition and submit it for approval again.

You can also view, copy, and edit each Forms Definition from the Forms Definition – Summary page by clicking Menu. These actions are available based on the roles assigned to you. For more information, refer [User Roles and Privileges](#).

### 16.8.2.3.1 Approving a Forms Definition

You can approve new forms based on the assigned roles.

To check about the assigned roles, refer [User Roles and Privileges](#).

To approve a Forms Definition:

1. In the Designer View, click **Menu** in the Forms Definition that is in **Pending Approval** status, and then click **Approve**, to access the **Configure page**.
2. Click **Approve** and then enter the required description for the approval in the Comments field.
3. Click **Submit**, to approve the form definition and view it in the **Data Entry page**.

Once the form is approved, you can [Editing/Amending Form Definitions](#) if you have **DMIDGNAMND** role assigned.

### 16.8.2.3.2 Rejecting a Forms Definition

You can reject new forms based on the assigned roles.

To check about the assigned roles, refer [User Roles and Privileges](#).

To reject a Forms Definition:

1. In the Designer View, click **Menu** in the Forms Definition that is in **Pending Approval** status, and then click **Reject**, to access the **Configure page**.
2. Click **Reject** and then enter the required description for the approval in the Comments field.
3. Click **Submit**.

The Forms Definition is rejected, moved to **draft** status. The form definition is displayed in Forms Definition Summary page. You can then edit the Forms Definition in draft status and submit it for approval again.

For more information on editing a Forms Definition, see [Editing/Amending Form Definitions](#).

## 16.8.3 Managing Form Definitions

You can view, edit, copy, and delete the existing Form Definitions from the Form Definition Summary Page, based on the assigned roles.

To check about the assigned roles, refer to [User Roles and Privileges](#).

In the Summary Page, highlight a specific Definition and click **Action**. The following options are displayed:

**Table 16-13 Action Details**

Action	Description
Viewing Form Definitions	View the <b>Member details</b> for a specific Member Definition.
Editing/Amending Form Definitions	Edit/amend the <b>Member details</b> of a form definition.
Copying Form Definitions	Copy the Member Definition Details and create another Member Definition by changing Alphanumeric Code, Numeric Code and Name.
Re-Uploading Form Definitions	Upload a new Excel sheet for an Excel upload form definition. You need to delete the attached excel sheet before uploading the new data.
Deleting Form Definitions	If you have the required role, you can delete a new Form that is in Awaiting Approval status.
Approving and Rejecting Form Definitions	If you have the required role, you can reject a new Form that is in Awaiting Approval status.

### 16.8.3.1 Viewing Form Definitions

You can view the form definition details using the View option, based on the assigned roles.

To check about the assigned roles, refer [User Roles and Privileges](#).

You can view the details of an individual Form Definition:

1. Highlight the Form Definition and click **Action**.
2. Click **View**, to access the **Form Definition page** with the selected Form definition details.

### 16.8.3.2 Creating Issue and Action for DMI

You can resolve any data issue identified in the Cloud framework by creating Issues and appropriate Actions on the Inbox page.

To Add/Edit data directly in the Stage master entities, follow these steps:

Ensure the **DMI forms** have been created and approved for the specific entity before making any changes.

- For detailed steps on creating a DMI form, refer to:
  - **Creating Forms using Excel Upload:** For bulk entries through Excel uploads.
  - **Creating Forms using Data Entry:** For single or limited entries through the Data Entry Designer form.

Once the DMI form is ready and approved, you can proceed with issues and actions. For more information, see [Create an Action for DMI](#).

### 16.8.3.3 Editing/Amending Form Definitions

You can modify both approved and rejected form definitions, based on the assigned roles.

To check about the assigned roles, refer [User Roles and Privileges](#). Forms that are already approved cannot be edited. You can amend the approved forms if you have **DMIDGNAMND** role assigned.

**Note**

You cannot amend an approved form, if the form has any pending data entry activity.

To edit individual form details:

1. Highlight the form definition and click the **Action**.
2. Click **Edit**, to access the **Form Definition page** with the details.  
To modify an approved form, click **Amend**.
3. Update the required information and click **Submit**.

**Note**

Do not edit the Business Key or As of Date attributes. .These are critical for data integrity and used for identifying unique records.

You can also **auto-approve** the form during submission.

The modified form definition is updated in the form design summary.

### 16.8.3.3.1 Adding/Editing a Draft Record

You can add a record to the table or edit a record set in the Draft status. The added record is set to Draft status.

To add or edit a draft record:

1. Select **Draft** from the **Status** drop-down list, to view all the entity records set to **Draft** status.
2. To add a new record, click **Add**.  
A new entry set to **Draft** status is added to Entity details page. This entry is empty. Edit the record to add the attribute details.
3. To edit a record, click **Edit** next to the record.
4. In the **Edit** page, enter the values in the attributes that you want to modify and click **OK**.  
You can repeat the steps for all the records for which the data needs to be entered.
5. To modify all the entries in a specific column, click **Bulk Update**.
  - a. Select the column to modify the data.
  - b. Enter the new value and click **OK**.
6. Click the modified record in draft status, and then click **Submit**.
7. After Publish, the status is changed from **Awaiting to Ready**. Refer [Editing Published Records](#) , to edit the records in **Ready** status.

### 16.8.3.4 Copying Form Definitions

You can copy individual Definition Details, to recreate another new Definition, if you have assigned roles.

To check about the assigned roles, refer [User Roles and Privileges](#).

To copy an existing form definition:

1. Highlight the Definition and click **Action**.
2. Click **Copy**, to view the **Form Definition Page**.
3. Edit the unique information and modify details like entity table, attribute filters, user and data security details and click **Save**, to create a new form definition.

### 16.8.3.5 Deleting Form Definitions

You can delete the form definitions that are in Draft status, based on the assigned roles.

To check about the assigned roles, refer [User Roles and Privileges](#).

To delete a form definition:

1. Highlight the form definition and click the **Action**.
2. click **Delete**.

The selected form definition is deleted after confirmation.

#### 16.8.3.5.1 Deleting Draft Records

You can delete the records in Draft status. If the record is approved and moved to Ready status, it cannot be deleted.

1. Select **Draft** from the Status drop-down list.

The entity records with Draft status are displayed for entering data are displayed.

2. Select a record and click **Delete**.

## 16.9 Protection

This section explains the General Data Protection Regulation (GDPR) related data protection methods implemented in Accounting Foundation Cloud Service (AFCS).

### 16.9.1 Data Redaction

Data Redaction is one of the data security features that protects sensitive data against unauthorized access and data theft.

Data Redaction is an in-built process in AFCS. It is applied automatically on all the business terms containing Personally Identifiable Information (PII).

To implement data redaction on a business term, on the **New Business Term** page, enable the Personally Identifiable Information button for that business term. For information about business term creation, see the Manage Business Terms section in the *OFS AFCS Data Catalog User Guide*.

# 17

## Managing Processes

Process Orchestration is a design and execution service that enables process pipeline developers to implement pipelines modeled by business analysts. Process pipeline developers use this framework to orchestrate Run Pipelines within AFCS, and also to design the artifacts that are used in the pipelines.

The Process Modeller and the Process Monitor are two key parts of Process Orchestration. The Process Modeller is used to model pipelines. It aids in representing the various artifacts required for modeling and provides implementation details of the AFCS process artifacts. The Process Monitor is used to monitor instantiated pipelines of AFCS.

AFCS supports orchestration of the **Run Pipeline**, which is any orchestrated pipeline consisting of AFCS tasks and service calls that run within the AFCS context.

### 17.1 Key Features of Process Orchestration

- Support for visual modeling of pipelines
- Provision of seeded pipelines with ability to modify them
- Ability to create new Run pipelines
- Support for registration of process, activity, and implementing transition logic separated from the modeling itself
- Built-in Orchestration Engine for task execution
- Provision of multiple components and canvas to visually stitch the AFCS components to form the Run pipeline
- Ability to monitor process during all stages of the execution process

## 17.2 Process Pipeline Flow

Figure 17-1 Process Pipeline Flow

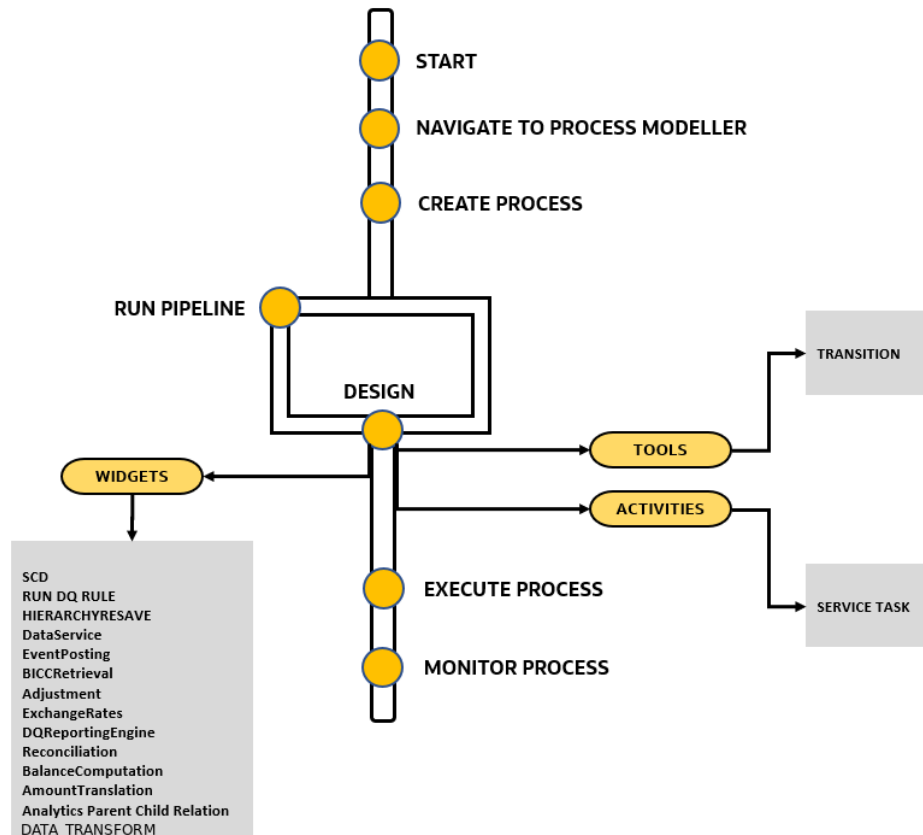

## 17.3 Access Process Orchestration

To access Process Orchestration, complete the following steps:

1. From the Home page, click **Process Orchestration** from the LHS menu.  
The **Process Modeller Summary** window is displayed.
2. Select any existing process flow to open it in the **Process Flow Canvas**, or click the **Add** icon to create a new process flow.  
For more details, see the [Designing and Executing Pipelines](#) Section.  
The **Process Monitor Summary** window is displayed.
3. To monitor any executed or currently running process, click the **Process Monitor** icon from the page header to view the **Process Monitor** summary page.  
See the [Process Monitor](#) Section for more information.

## 17.4 Access Process Orchestration for New User Interface

To access Process Orchestration, complete the following steps:

1. From the Home page, click **Process Orchestration** from the LHS menu.  
The **Process Modeller Summary** window is displayed.
2. Click **Switch to New UI** link to experience the new PMF user interface.
3. Select any existing process flow to open it in the **Process Flow Canvas**, or click the **Create** to create a new process flow.

For more details, see the [Designing and Executing Pipelines](#) Section.

The **Process Monitor Summary** window is displayed.

4. To monitor any executed or currently running process, click the **Process Monitor** option from the page header dropdown to view the **Process Monitor** summary page.

See the [Process Monitor](#) section for more information.

The new PMF user interface is displayed as follows:

**Figure 17-2 PMF New UI**

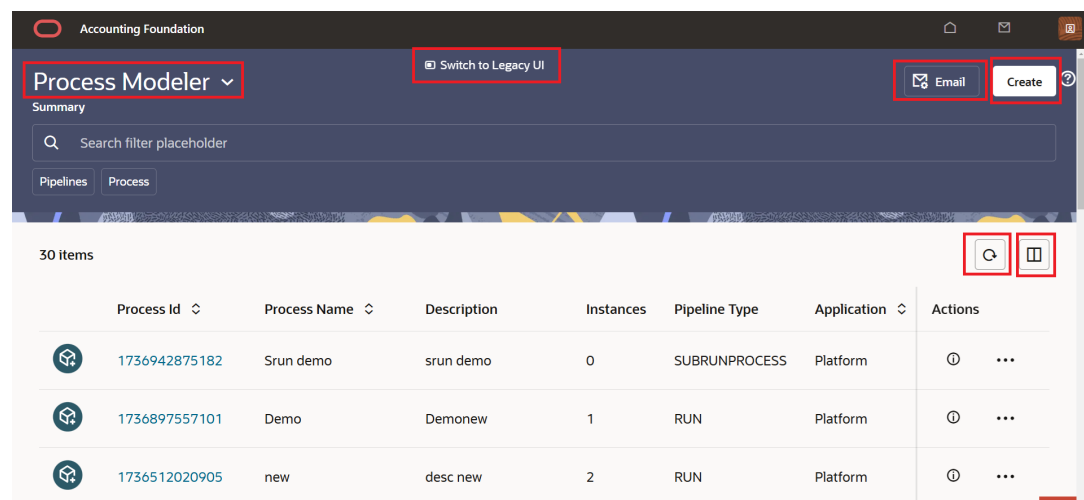

The new PMF user interface has the following enhancements:

- Header consists of the drop down for the Process Modeller, Process Monitor and Dashboard options.
- **Create** button to create a new PMF process.
- **Email** button to navigate to PMF Email notification.
- **Refresh** button to refresh the Summary page.
- **Columns** button to display the column details that you wish to view in the summary page.
- **Scheduler** button to schedule a PMF process.

**Note**

You can switch back to the legacy user interface at any point in time using the **Switch to Legacy UI** link available at the top of the page.

## 17.5 Designing and Executing Pipelines for New User Interface

You can design and execute pipelines using the new Process Modeler user interface.

### 17.5.1 Process Modeler for the New User Interface

The Process Modeler page displays existing pipelines along with their details such as: Process ID, Process Name, Process Code, Description, Singleton, Pipeline Type, Instance, Actions and Application.

On this page, you have options to:

1. Click **Create** to create a new pipeline.
2. Click the process ID to launch and edit the pipeline.
3. Click the **Menu** button and do the following for each pipeline:
  - View a process flow
  - Launch the process in a new window.
  - Copy a process flow
  - Delete a pipeline.
  - Monitor the pipeline in the **Process Flow Monitor** window
  - Execute a pipeline

Use the **Search** grid to search for a pipeline by providing a keyword containing the process ID, process name, or description. Click the **Reset** icon to reset the search fields.

You can narrow down your search results by additionally selecting the **Pipelines** options to filter pipelines based on pipeline type. Example: To view only **Run Pipelines**, click inside the **Pipeline** list, and select **Run Pipeline**. To view only **Sub Run Process**, click inside the **Pipeline** list, and select **Sub Run Process**. Remove the other pipeline types if already selected and click **Search**.

You can also sort the pipelines on this page based on the **Process ID**, **Process Name**, or **Application**. Click the **Columns** icon and select the columns that you wish to display.

For more information on the Process Monitor, select the Process Monitor option from the drop down and see [Process Monitor for the New User Interface](#) window.

### 17.5.2 Canvas and Components for New User Interface

The canvas is used to design the process flow. There are Expand/Compact icon, Application Rules, Data Fields, Execution icon at the top of the canvas. After the creation of a process, from the Start node, you can click + icon to add these components such as Activities, Transition and Widgets into the canvas, connect them, and configure each component to design your process flow.

**Note**

Double-click on the Activities on the canvas or click the **More** icon, select **Properties** of a specific activity to view and edit the Activity details.

## 17.5.2.1 How to Use a Service Task in the New User Interface

1. Click + icon on the source component, under **Activity** select the **Service Task** icon and it is added on to the canvas.
2. Double-click the **Service Task** component on the canvas to display the configuration window with the **Activity** tab selected.

**Figure 17-3 Example of a Service Task in New UI**

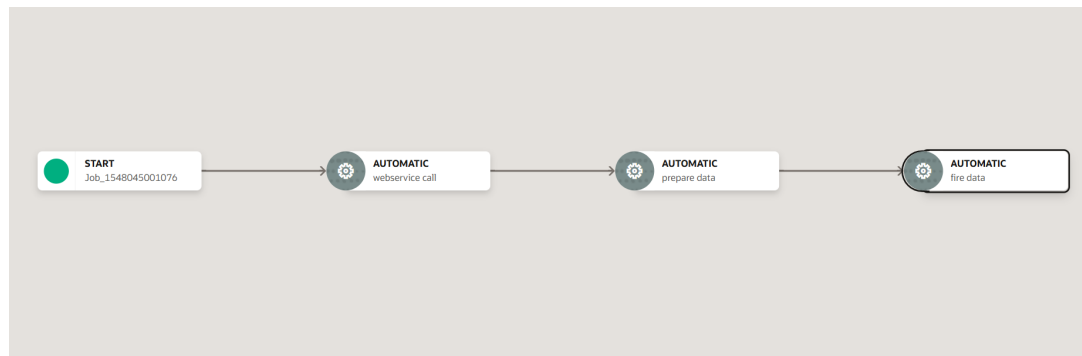

### 17.5.2.1.1 Activity Tab in the New User Interface

1. **Activity ID** is auto-populated.
2. By default, the activity ID is populated in the name field. You can enter your own **Activity Name** and **Activity Description**.
3. Select **Status** and **Outcomes** options as required.
4. Click **Save** to save the activity details.

### 17.5.2.1.2 Implementation Tab in the New User Interface

1. Click the **Implementation** icon on the left in the configuration window.
2. Select the **Execution Rule** from the drop down that has to be executed for this activity. All **Application Rules** of type **Execution Rule** available in your process are listed in drop down.
3. Add **Parameters** you want to pass to the Execution Rule.
  - Click + next to **Parameters**. The **Participant Details** window is displayed.
  - Select the **Data Fields** to which you want to pass the value. This list displays all data fields for the current process or package.
  - Select the **Parameter Type**. Choose **Static** if you want to pass a static value to the selected data field. Enter the **Value**. Choose **Dynamic** to pass the value during the execution of the workflow.
  - The parameters you added are displayed under the **Parameters** in the **Implementation** tab.

4. Select the **Pre Rule**, which is the Application Rule you want to execute before executing the Execution Rule. Select the Application Rule that you want to set as the pre rule from the drop down.
5. Select the **Post Rule**, which is the Application Rule you want to execute after executing the Execution Rule. Select the Application Rule that you want to set as the post rule from the drop down.
6. Click **Save** to close the configuration window.

## 17.5.2.2 Executing Parallel Tasks

A Parallel Gateway is used to execute multiple tasks in parallel. In the usual flow, tasks are executed sequentially.

**Figure 17-4 Execution of Parallel Tasks Flow in New UI**

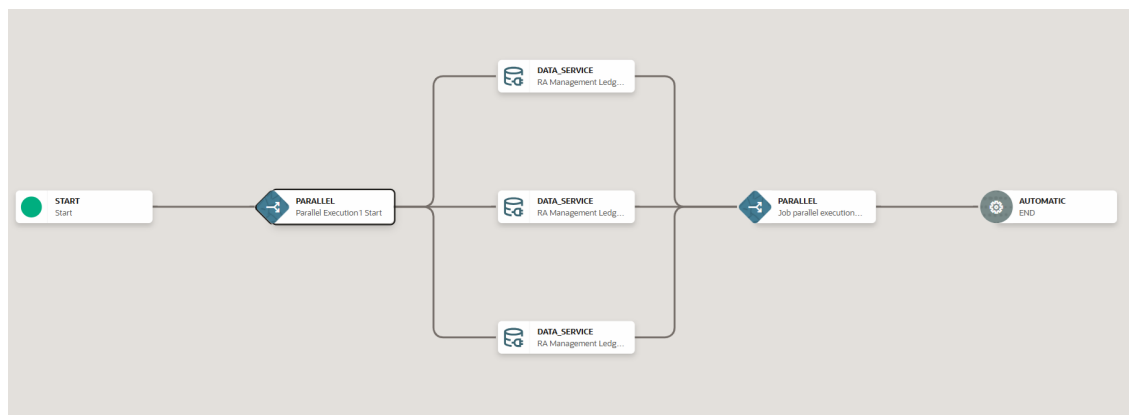

In the example shown, when the Parallel Gateway is invoked, all the OFSAA components that are placed between Parallel Gateways, are executed simultaneously. After all components are executed, the execution moves to the next activity in the Process Flow.

### **Note**

In case if any one of the task fails as part of parallel gateway, the other ongoing parallel tasks executions are completed. The status of the activities get updated appropriately even though one or more activities fail.

**Table 17-1 PMF Run Pipeline Design**

<b>Do's for a Gateway ( Parallel and Multichoice)</b>	<b>Dont's for a Gateway ( Parallel and Multichoice)</b>
<p>Ensure to begin and end with the same gateway during run pipeline design.</p> <p>Ensure to add a service task if a parallel gateway is the last executing activity.</p>	<p>A parallel gateway cannot exist within another parallel gateway.</p> <p>Multiple transitions are not supported for any activity in a run pipeline. Therefore, you must only use a parallel gateway.</p>

**Table 17-1 (Cont.) PMF Run Pipeline Design**

Do's for a Gateway ( Parallel and Multichoice)	Dont's for a Gateway ( Parallel and Multichoice)
Tasks which start from a parallel gateway must end in the successive closing parallel gateway.	
Execution of a pipeline will begin from the <b>Start</b> activity. Therefore, the transition cannot be stopped for this activity.	

For more information on the Transition and Gateways, see [Transition](#) and [Gateways](#).

### 17.5.2.2.1 How to Use Parallel Gateways in the New User Interface

This section explains how to design parallel tasks using Parallel Gateways. For example, executing the Reconciliation widget in parallel for different rules.

1. Create a process in the Process Modeler canvas.
2. On the **Process Flow** page, you will see a **START** activity is already present on the canvas. This activity indicates the beginning of the process.
3. Click + icon on the Start node, under **Transition**, click a **Parallel Gateway** widget on to the canvas.
4. Connect the **START** activity with this **Parallel Gateway** widget.
5. Click + icon on the source component to add the widgets representing the tasks that run in parallel on to the canvas. Example: add multiple Reconciliation widgets on to the canvas.
6. Connect the Parallel Gateway widget with each of these widgets representing tasks that must run in parallel. This represents the beginning of the transition.
7. Click + icon on the component to add another Parallel Gateway widget on to the canvas.
8. Connect each of the widgets to this newly added Parallel Gateway widget. This represents the end of the transition.
9. Configure the Reconciliation widgets based on your requirement.
10. Proceed in this manner to create your pipeline with one or multiple parallel tasks.
11. Click **Save**.

### 17.5.2.3 How to Use a Widget in the New User Interface

1. On the PMF canvas, from the Start Node, click + icon and select the Widgets option and under **Widget** window select the required widget to add on to the canvas.
2. Double-click the widget to open the configuration window for the widget. The **Activity** tab is selected.
3. Enter the **Activity Name** and **Activity Description**.
4. Specify the **Dynamic Parameters** for the widget and click **Save**. For more information, see the [Dynamic Parameters for Widgets](#) section.

## 17.5.3 Run Pipeline for the New User Interface

A Run Process is used to create a Run Definition in the Rule Run Framework (RRF). A Run Pipeline is the visual representation of the Run enabled through Process Orchestration.

### An Example of Run Pipeline

Figure 17-5 Run Pipeline in a New UI

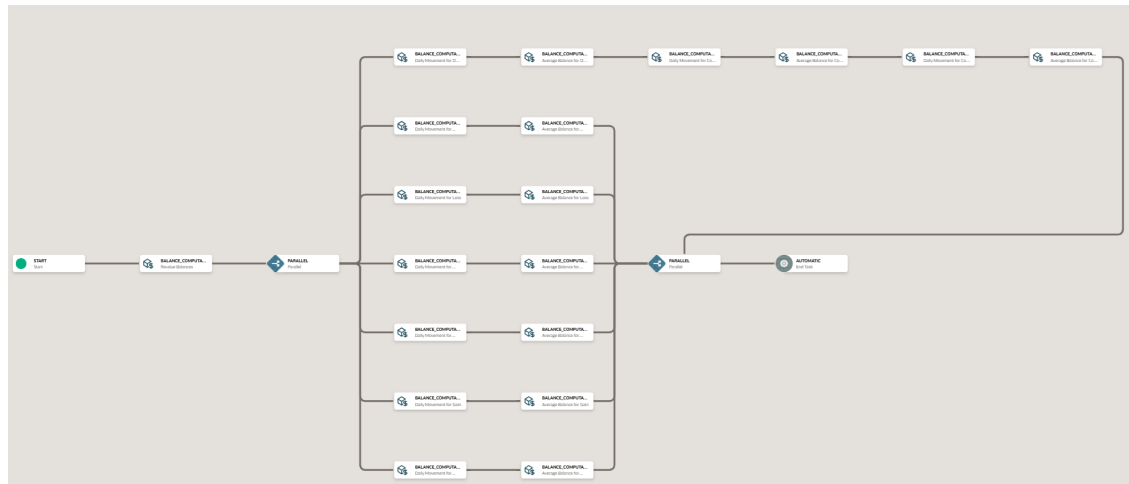

### 17.5.3.1 Creating a Run Pipeline in the New User Interface

1. Click the **Create** button in the **Process Modeler Summary** page.
2. Enter a **Process Name** , **Process Code** and **Process Description**. The **Process ID** is a unique system-generated value.

#### Note

When you enter the Process Name and try to enter the Process Code value, the Process Name (removing spaces and special characters) is auto-populated in the Process Code field, by default. You can update the auto-populated value in the Process Code field.

3. Select the appropriate package from the **App Package ID** drop-down.
4. Select **Run Pipeline** from the **Process Type** drop-down list.

#### Note

Enable Singleton option is only available if the Process Type is selected as Run Pipeline.

5. Select the service that you want to connect to from the **Service ID Workspace** drop-down list.

The list displays all the services that are mapped to the AFCS Service.

6. Select the **Enable Singleton** option to run only one instance of this run pipeline during execution.  
A confirmation message such as "Singleton enabled. Only one instance of this process can run at a time" is displayed.
7. Click the **Create** button to save the entered details.  
The Process Flow canvas is displayed.
8. By default, the START activity appears on the canvas indicating the beginning of the process.
9. Click + icon from the Start node to add components from the available list. You can add service tasks, sub pipeline, gateways, and widgets on the canvas.
10. To connect one component with another existing component, then click + icon, select the source component and choose **Start Link**. Next, click on the destination component and click **End Link**.
11. Proceed to link all the components per your requirement.

**Figure 17-6 Singleton Enabled in Process Canvas for a Run Pipeline**

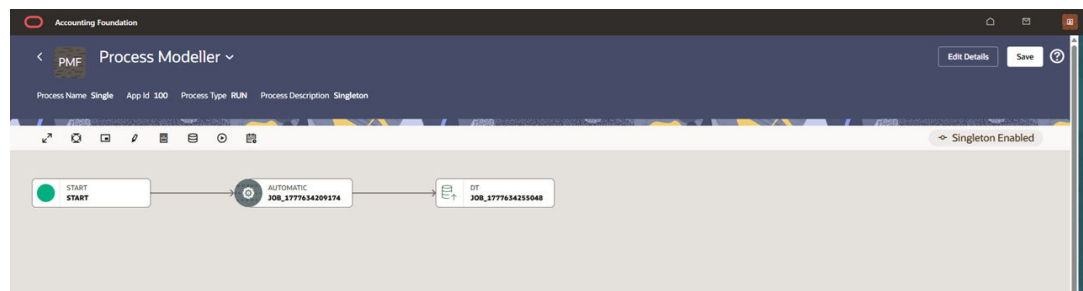

12. Click **Save**. The Save in Progress window is displayed. Once the process is complete, the Process is saved successfully message is displayed.

**Figure 17-7 Singleton Process Modeller Summary Page**

The screenshot shows the Oracle Process Modeller Summary page. It features a search bar and a table with 41 items. The table columns are: Process Id, Process Code, Process Name, Description, Singleton, Instances, Pipeline Type, Application, Updated By, and Actions. The table lists various processes, including 'Single', 'watcher3004202615', 'watcher3004202614', '30041pipeline', 'testcreate005', 'watcher3004202613', 'watcher30041', and 'watcher27041'.

Process Id	Process Code	Process Name	Description	Singleton	Instances	Pipeline Type	Application	Updated By	Actions
1777634188318	Single	Single	Singleton	☑	0	RUN	Platform	fsdftest	🔄 ⋮
1777546122572	watcher3004202615	watcher3004202615	desc	-	1	RUN	Platform	fsdftest	🔄 ⋮
1777543615850	watcher3004202614	watcher3004202614	desc	-	0	RUN	Platform	fsdftest	🔄 ⋮
177753993832	30041pipeline	30041pipeline	desc	-	6	RUN	Platform	fsdftest	🔄 ⋮
1777533283325	testcreate005	testcreate005	test	-	1	RUN	Platform	fsdftest	🔄 ⋮
1777531516649	watcher3004202613	watcher3004202613	desc	-	342	RUN	Platform	fsdftest	🔄 ⋮
1777531719652	watcher30041	watcher30041	desc	-	3	RUN	Platform	fsdftest	🔄 ⋮
1777268411966	watcher27041	watcher27041	desc	-	1	RUN	Platform	fsdftest	🔄 ⋮

For more information on modifying, copying, viewing and deleting pipelines, see [Additional Functionalities](#).

### Edit Singleton Process Details

13. From the Process Modeller page, select the required process that you wish to edit.
14. Click the Process ID link and the Process canvas relevant to the run pipeline is displayed.
15. Click **Edit Details** and disable the Singleton option.

**Figure 17-8 Edit Run Pipeline**

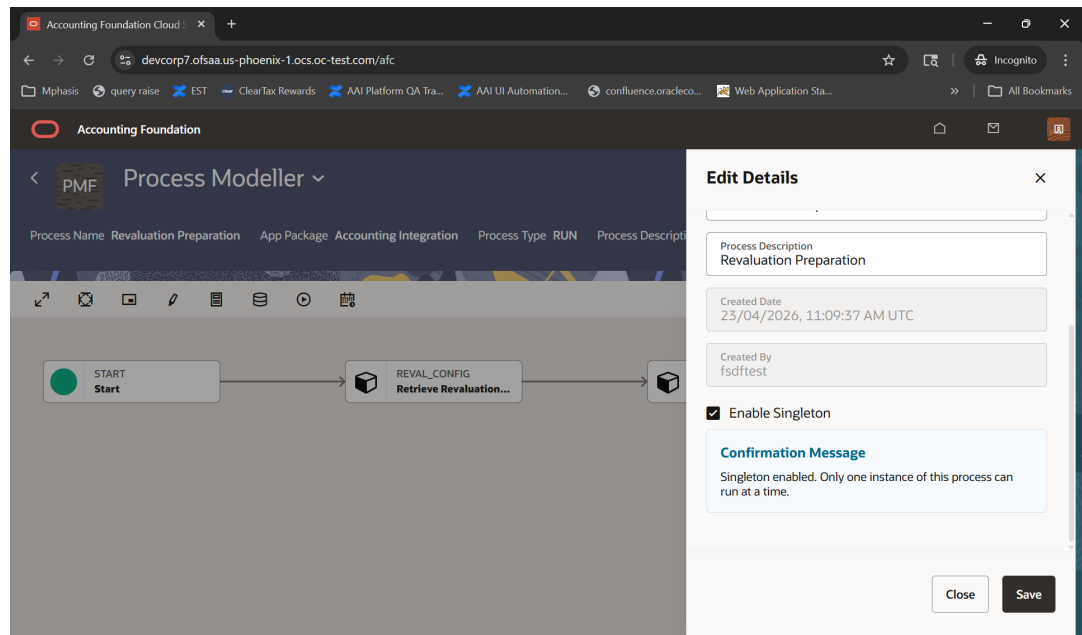

16. Click **Save**.

#### 17.5.3.1.1 Creating a Sub Run Process Pipeline

Sub Pipeline provides the reusability of Pipelines. Using the Sub Pipeline component, you can call another Pipeline from your parent Pipeline.

1. Click the **Create** button in the **Process Modeler Summary** page.
2. Enter a **Process Name**, **Process Code** and **Process Description**. The **Process ID** is a unique system-generated value.

#### **Note**

When you enter the Process Name and try to enter the Process Code value, the Process Name (removing spaces and special characters) is auto-populated in the Process Code field, by default. You can update the auto-populated value in the Process Code field.

3. Select the appropriate package from the **App Package ID** drop-down.
4. Select **Sub Run Pipeline** from the **Process Type** drop-down list.
5. Select the service that you want to connect to from the **Service ID Workspace** drop-down list.

The list displays all the services that are mapped to the AFCS Service.

6. Click the **Create** button to save the entered details.

The Process Flow canvas is displayed.

7. By default, the START activity appears on the canvas indicating the beginning of the process.
8. Click + icon from the Start node to add components from the available list. You can add service tasks, sub pipeline, gateways, connectors, and widgets on the canvas.
9. To connect one component with another existing component, then click + icon, select the source component and choose **Start Link**. Next, click on the destination component and click **End Link**.
10. Proceed to link all the components per your requirement.
11. Click **Save**.

#### 17.5.3.1.1.1 Adding a Sub Process to a Sub Run Pipeline

Reusability is important while designing your pipeline. Sub Run Pipeline is the mechanism in the PMF to call another pipeline from your parent pipeline.

1. From the PMF canvas, click + icon and select the Sub Pipeline from the Activity.
2. Double-click the Sub Pipeline icon on the canvas. The Sub Process Details window is displayed.

**Figure 17-9 Sub Pipeline Activity Details**

**Activity Details** X  
JOB\_1745983996951

Activity ID  
JOB\_1745983996951

Activity Name  
JOB\_1745983996951

Activity Description  
JOB\_1745983996951

Activity Type  
SUBPROCESS

App Package ID  
Platform

Process ID  
1745913642983 - check rating

Close Save

3. Enter the details as given in the table:

**Table 17-2 Sub Pipeline Information**

Report Name	Period to Date
App Package ID	Select the Application Package from which you want to call a process, from the drop-down list. The package IDs that are seeded from the backend are displayed in the list.
Process ID	Select the Process that you want to call within your workflow, from the drop-down list. The list displays all processes defined for the selected Application Package.

4. Click **Save** to save the sub pipeline details.

**Figure 17-10 Create Sub run pipeline**

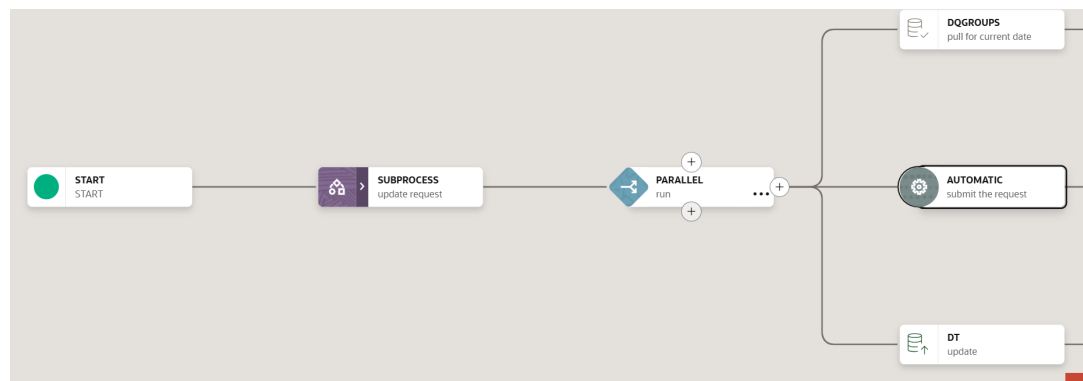

Click > icon in the Sub process to view the Sub run pipeline details.

To copy an activity, click the **More** icon in the source activity and select **Copy activity** from the available list and choose the node where you wish to paste this activity. Click the **Add** icon and select **Paste activity**. All the relevant details of the copied activity are available in the newly added activity.

To delete an activity, click the **More** icon in the activity that you wish to delete and select **Delete activity** from the available list.

**Figure 17-11 Sub Process details**

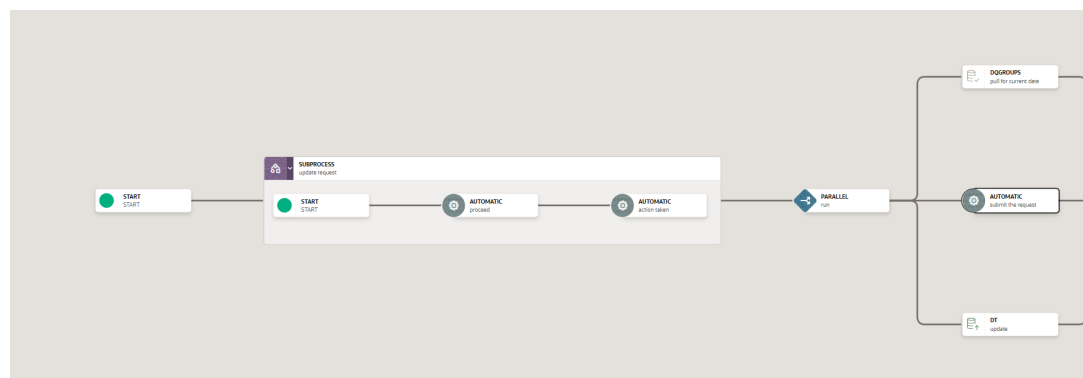

## 17.5.4 Add a Data Field from the New User Interface

1. On the **Process Modeler** page, click the pipeline to which you want to add a Data Field.
2. Select **DataFields** from the header to display the **Data Fields** window.
3. Click **Create** to display the **Addition of Data Field** window.
4. Provide the details described in the following table and click **Save** to save the details:

**Table 17-3 Data Field Details Description**

Field Name	Description
Data Field Code	Enter the Variable Name/Code, which will be used to read or write into this variable. This field is non-translatable.
Data Filed Name	Enter the name of the Data Field.
Data Field Description	Enter a brief description.
Data Field Type	Select the Data Field Type.
Initial Value	Enter the initial value for the data.
Is Mandatory	Applies to the <b>AOM</b> Data Field Type. <b>Yes</b> is the default selection for AOM.
Scope	Select the scope of the Data Field. Options are: <ul style="list-style-type: none"> <li>• <b>Process</b> - To use the Data Field only in the current process.</li> <li>• <b>Package</b> - To use the Data Field across all the processes in the package.</li> </ul>

For more information on the data fields and the system data fields, see [Data Fields](#) and [System Data Fields](#).

## 17.5.5 Executing Run Pipeline from the New User Interface

After creating your Run pipeline, your next step is to execute it. To execute a Run pipeline, complete the following steps:

1. From the **Process Modeler Summary** page, click the Actions button corresponding to Run pipeline you want to execute and select **Execute Run**. The **Execution** window is displayed.
2. Select the **Execution Type**, enter the required fields and click **Execute**.

**Figure 17-12 Execute a Run pipeline using New UI**

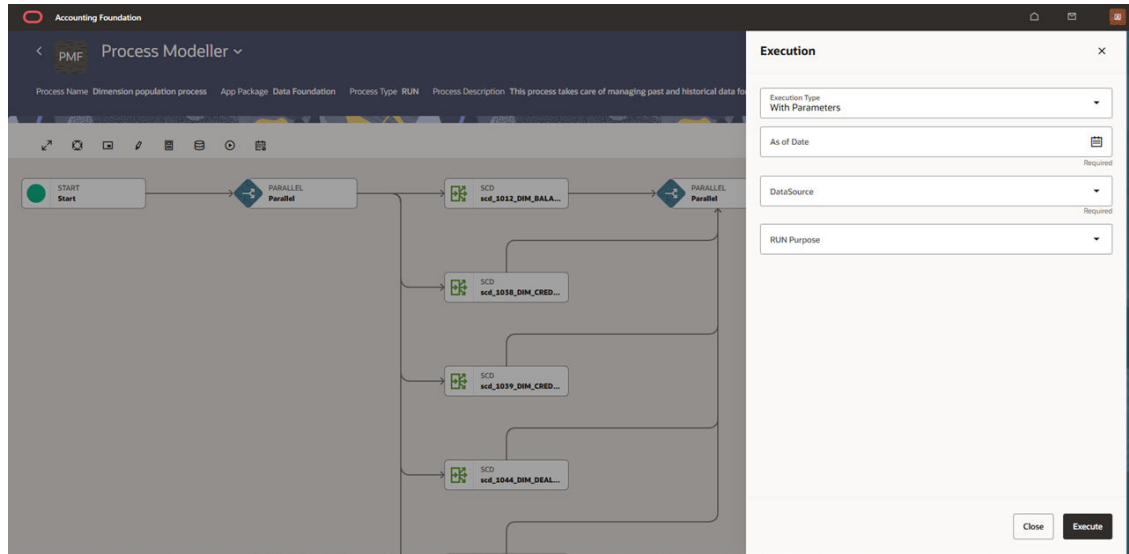

The execution is triggered using the selected FIC MIS DATE. The RUNSKEY is generated and inserted into the “DIM\_RUN” table. For the RUNSKEY generated, the corresponding user-selected parameters are inserted into the “RUN\_EXE\_PARAMETERS” table.

You can use the Process Flow Monitor to view the status of the execution as the Run pipeline is executed.

If the Run pipeline is enabled as Singleton, then users will not be able to run multiple instances of that pipeline and the following message is displayed.

**Figure 17-13 Re-execution Error of a Singleton Pipeline**

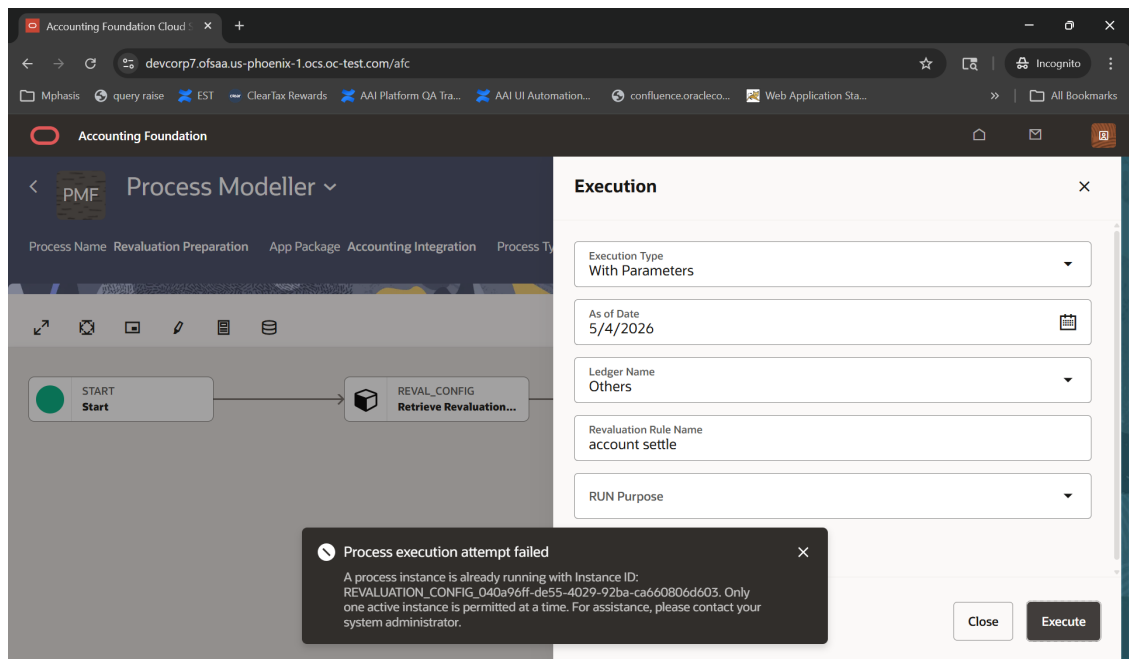

## 17.5.6 PMF Dashboard for New User Interface

When there are multiple pipelines running in parallel, monitoring the processes to find out if they have executed successfully or otherwise, information about the tasks within pipelines that have completed, failed, canceled, and in-progress yet becomes important.

The Process Modeling Framework (PMF) Dashboard displays granular level execution details of all PMF processes belonging to Loader components and Data Quality executions within a environment (tenancy). Only authorized users belonging to the Accounting Foundation Admin Group or Accounting Foundation Operations User Group will have access to the PMF Dashboard. For each PMF process, these authorized users can drill down and view the related activities and further into the events recorded for each activity along with information such as the timestamp, event messages, and event error codes. This information aids you to gauge the progress made by each task. You also have the option to monitor a pipeline and view it on the PMF canvas.

Navigation to the PMF Dashboard page is through the drop down on the Process Modeler page. On the dashboard page, you can view detailed information about the processes that have run and the details of the events (activities) that have occurred during the execution of the tasks.

You have options to search the activities and tasks: for example, completion status, Process ID, or execution date. You can also export the results as a report to an Excel or CSV format.

### Note

The set of APIs published under this section are eventually consistent. For more information, see the *Fetching the PMF Dashboard Process Status* section in the [API User Guide](#)

### 17.5.6.1 View and Filter PMF Dashboard for the New User Interface

The PMF Dashboard displays detailed, drill-down information about the processes that have run and the details of the events (activities) that have occurred during the execution of the tasks. You can use the filters provided to quickly search and locate a PMF Process that has run regardless of whether process completed or failed.

### Note

The PMF Dashboard supports wildcard search where you can search for objects without having to provide the complete activity name, process name, or instance ID. In addition, the search feature is case-agnostic; you can type the search strings in upper or lower case.

To view and filter the PMF Dashboard:

1. From the **AFCS Home** page, select **Process Orchestration**.  
The **Process Modeler** page is displayed.
2. Click **Switch to the New UI** link and the new Process Modeler page is displayed.
3. Click the **Process Modeler** drop down and select the **Dashboard** option. The **Process Dashboard** page appears and displays the PMF processes that have run.

4. You can filter the PMF dashboard to quickly search for a PMF process you are interested in. Note that the search is case-sensitive. The following filter options are available:
  - **Process Status:** Select one or multiple statuses to filter the PMF dashboard. For example: to see all processes that have failed, click **Process Status** under the search bar and select **Failed** to view a list of all the processes that have failed.
  - **Run Purpose:** Enter the run purpose value or select the Run purpose using the search bar to list the processes with a specific run purpose details.
  - **Process Name:** Enter the process name.
  - **Process ID:** Enter the process ID.
  - **Process Instance ID:** Enter the process Instance ID.
  - **More Filters:** Select from one of the multiple options available.
  - **Execution Date:** Select a time period or a date range based on the time zone in which the user is logged in.

Additionally you can select **Run Purpose** option to filter the records specific to Run Purpose.

The dashboard is refreshed and the PMF process(es) matching your filter criteria are displayed.

5. You can drill-down each PMF process to view the activities (tasks) that have been defined for that process. Use the additional filters to filter activities based on **Activity, Activity ID, Event Parameters, Event Message, and Event Error Code**. To apply a filter, click inside the search bar, select the filter, and press Enter.
6. Each PMF process has the following information:
  - **Process Instance ID:** The unique system-generated value that identifies the process instance.
  - **Data Source ID:** The Data Source ID of the process.
  - **Run Params:** The input parameters provided to execute this process.
  - **Run Purpose:** The Run purpose of the execution.
  - **As Of Date:** The As of date.
  - **Run Skey:** The unique number created for each instance.
  - **Start Time:** Start time of the process execution.
  - **End Time:** End time of the process execution.
  - **Duration:** Duration of the process execution.
  - **Status:** Indicates if the process has completed, failed, was canceled, or is still running.
  - **Monitor:** Click this icon to view the progress of this process on the PMF canvas.
7. Click the PMF process link to drill down and display the activities associated with this process. The associated activities (for example: SCD, Connectors, Run DQ Rule, and so on) are displayed. For each activity, the following information is available:
  - **Component:** The component type.
  - **Start Time:** Start time of the activity execution.
  - **End Time:** End time of the activity execution.
  - **Duration:** Duration of the activity execution.
  - **Status:** Indicates if the activity has completed, failed, was canceled, or is still running.

8. Click the activity name link to drill down further and view details of the events within this activity. For example: if the activity is an **Insert Connector**, the following event information is displayed:
  - **Timestamp**: The latest record is displayed on top.
  - **Number of error records**: The number of error records.
  - **Event**: The event that is being recorded.
  - **Volume Number of records loaded**: The number of records that were loaded.
  - **Event message**: Status of the event completion whether it was aborted or running or completed.

For more information exporting the PMF Dashboard report, see [Exporting PMF Dashboard Report](#).

## 17.5.6.2 Exporting PMF Dashboard Report

You can also export the PMF dashboard contents as a report in Excel or CSV formats. Here again you have options to filter the data that is exported.

To export contents of the PMF Dashboard into a report:

1. On the **PMF Dashboard** page, use the filters to select the PMF process(es) and the activities within the PMF process(es) you are interested in.
2. Click **Export**.
3. Choose the format for your report (Excel or CSV).
4. You need to apply at least one filter criteria to export the report as there is a limit to the number of records you can export. To filter the contents to export to your report, click the **With Filter** option and select the filter criteria from the search box.
  - **Process Status**- Select one or multiple statuses to filter the PMF dashboard. For example: to see all processes that have failed, click **Process Status** under the search bar and select **Failed** to view a list of all the processes that have failed.
  - **Date Range**- Select a time period or a date range based on the time zone in which the user is logged in.
  - **Process Name**- Enter the process name.
  - **Run Purpose**- Enter the run purpose value or select the Run purpose using the search bar to list the processes with a specific run purpose details.
  - **More Filters**- Select from one of the multiple options available.
5. Click **Export** and save the report file to a local directory. The report will contain details of the selected process(es), activities within the process, and the tasks within the events.

### Note

The export file can contain a maximum of 6500 records (rows) only. Hence it is recommended to use at least one filter when exporting the contents of the Dashboard to a report.

## 17.5.7 Scheduler Services for a PMF Process

Scheduler integration with the PMF is a key functionality which allow users to schedule a PMF Process from the PMF Canvas or the Process Modeler Summary page. This integration focuses on the functionalities such as, Create, View, Edit and Delete the schedules within the PMF.

You can schedule the execution only for a Run pipeline and not for a work flow or a for a Sub run pipeline.

1. You can select a specific process from the Process Modeler summary page, under **Actions** drop down, click **Schedule** or from the PMF canvas page, click the **Scheduler** icon.

The Scheduler summary window is displayed.

2. Click **Create Schedule** to create a scheduler for the selected PMF process.
3. You can schedule a process to execute Once, Daily, Weekly, Monthly, Quarterly and Cron. Based on selection, enter the required fields and click **Continue**.
4. Click **Continue** and the Execution window is displayed.
5. Select the Execution Type as **With Parameters** from the drop down list, enter information in the required fields and click **Schedule**.

Process execution scheduled successfully message is displayed.

6. You can click on the **Scheduler** icon to view the Scheduler Summary page and the newly added schedule details are displayed.

## 17.5.8 Process Monitor for the New User Interface

Use the Process Monitor to monitor the current stage of a process. After integrating with a service, a workflow is invoked. After it is invoked, the workflow goes through all the defined stages. Using the Process Monitor, you can view all the stages of the workflow such as current stages, stages to follow, if any, and finished.

Your User Group must be mapped to the Function Role WFMAcc (Workflow Monitor Access) to access the Process Monitor.

From the **Process Modeler** drop down, click the Process Monitor option to view the Process Monitor page. All workflows that are invoked from the service are displayed along with details such as **Entity Name, Object ID, Process Code, Process Name, Process Description, Singleton, As of Date, Execution Start Time, Executed By, Status, Run Purpose** and so on.

### Note

You can use the **Columns** button to display the column details that you wish to view in the summary page.

To monitor only a selected pipeline, on the Process Modeler summary page, click the **Actions** button corresponding to that pipeline and select **View**. The execution details are displayed.

Click the Actions button corresponding to the selected pipeline to view options to:

- Resume: To resume a Run pipeline.

- Re-run: To execute a Run pipeline again irrespective of the previous execution status.
- Abort: To abort an ongoing Run pipeline.
- Launch a new window.
- View: To view the execution details.

#### ① Note

In case of Disaster recovery (DR) after switch over to the secondary site, the processes that are in running status should be aborted and resume to proceed further.

To return to the Process Modeler page, select the Process Modeler option from the Process Monitor drop down.

Use the **Search** field to search for a specific pipeline by providing a keyword from either the Object ID, Process Name, or Process Description of the process you are looking for and click **Search**.

### 17.5.8.1 Monitoring a Process from the New User Interface

From the **Process Monitor** window, click the Object ID link corresponding to the process you want to monitor.

The status of the activity is represented as: **Completed**, **Failed**, **Cancelled**, or **Running**.

You can also set auto-refresh in the header. Select **Enabled** in **Auto Refresh**, enter a value from 1 to 10 in **Refresh Interval (In Min)**.

For more information on viewing the execution logs, see [Viewing Activity Execution Logs](#).

For more information on Abort, Re-run and Resume pipelines, see [Abort Run pipeline](#), [Re-run Run pipeline](#) and [Resume Run pipeline](#).

## 17.6 Designing and Executing Pipelines

You can design and execute pipelines using the Process Modeller.

### 17.6.1 Process Modeller

The Process Modeller page displays existing pipelines along with their details such as: process ID, process name, process description, version, instance, application, and last modified date, and last modified by.

On this page, you have options to:

1. Click + to create a new pipeline.
2. Click the process name link to launch and edit the pipeline.
3. Launch the process in a new window.
4. Delete a pipeline.
5. Click the **Menu** button and do the following for each pipeline:
  - View a process flow
  - Copy a process flow

- Monitor the pipeline in the **Process Flow Monitor** window
- Execute a pipeline
- Apply a filter condition to a Run pipeline

Use the **Search** grid to search for a pipeline by providing a keyword containing the process ID, process name, or description. Click the **Reset** icon to reset the search fields.

You can narrow down your search results by additionally selecting the **Pipeline Filter** options to filter pipelines based on pipeline type. Example: To view only **Run Pipelines**, click inside the **Pipeline Filter** list, and select **Run Pipeline**. Remove the other pipeline types if already selected and click **Search**.

You can also sort the pipelines on this page based on the **Process ID**, **Process Name**, or **Application**. Click the **Sort By** drop-down and select the sort criterion.

Click to go to the [Process Monitor](#) window.

## 17.6.2 Canvas and Components

The Process Flow Tab has a toolbar and canvas. The canvas is used to design the process flow with the LHS toolbar consisting of Tools, Activities, and Widgets. Drag these components and drop them into the canvas, connect them, and configure each component to design your process flow.

### 17.6.2.1 Service Task

A Service Task invokes an application component (for example, activity to invoke a business rule to calculate a certain threshold). It is an automatic task that gets triggered in the process flow and is typically used to execute the business logic that is defined through an **Execution Rule** type application rule.

Service Tasks are used to invoke an External Model Service through stored procedures and functions.

**Figure 17-14 An Example: Service Tasks Flow**

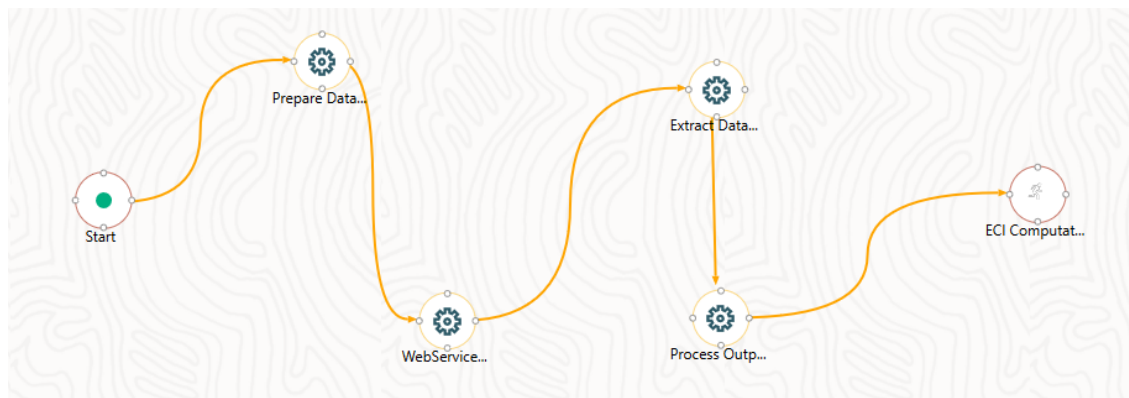

#### 17.6.2.1.1 How to Use a Service Task

1. Expand the toolbar on the left, click and drag the **Service Task** icon under **Activity** on to the canvas.

2. Double-click the **Service Task** component on the canvas to display the configuration window with the **Activity** tab selected.

#### 17.6.2.1.1.1 Activity Tab

1. **Activity ID** is auto-populated and you can mouse-over the **i** icon to view it.
2. By default, the activity ID is populated in the name field. You can enter your own **Activity Name** and **Activity Description**.
3. Select **Status** and **Outcomes** options as required.
4. Click the tick mark icon to save.
5. Click anywhere outside the configuration window to close it.

#### 17.6.2.1.1.2 Implementation Tab

1. Click the **Implementation** tab on the left in the configuration window.
2. Click the search icon to select the **Execution Rule** that has to be executed for this activity. The **Participant Details** window is displayed with all **Application Rules** of type **Execution Rule** available in your process.

For more information on how to define an Application Rule, see the Application Rules section.

- Click the name link of the Application Rule to view its details.
  - Select the required rule and click **Ok**.
  - Click outside the window to return to the configuration window.
3. Add **Parameters** you want to pass to the Execution Rule.
    - Click + next to **Parameters**. The **Participant Details** window is displayed.
    - Select the **Data Fields** to which you want to pass the value. This list displays all data fields for the current process or package.
    - Select the **Parameter Type**. Choose **Static** if you want to pass a static value to the selected data field. Enter the **Value**. Choose **Dynamic** to pass the value during the execution of the workflow.
    - The parameters you added are displayed under the **Parameters** in the **Implementation** tab.
  4. Select the **Pre Rule**, which is the Application Rule you want to execute before executing the Execution Rule. Click the corresponding search icon to select the Application Rule that you want to set as the pre rule.
  5. Select the **Post Rule**, which is the Application Rule you want to execute after executing the Execution Rule. Click the corresponding search icon to select the Application Rule that you want to set as the post rule.
  6. Click **Save**.
  7. Click anywhere outside the configuration window to close it.

### 17.6.2.2 Transition

The Transition component is used to control the flow between various components in the Process Flow. Transition connects two activities and the flow is configured based on a Conditional Expression or Decision Rule.

### 17.6.2.2.1 Gateways

A split refers to a condition where an incoming transition is split into multiple transitions. In merge, multiple incoming transitions are merged into a single transition. Splitting and merging of activities are modeled through gateways. A gateway can be Sequential, Parallel, or Multi Choice.

- **Parallel Gateway:** A Parallel Gateway is used when you have multiple transitions or flows that should be executed in parallel.
- **Sequential Gateway:** A Sequential Gateway is used when you have multiple transitions or flows that should run in sequence.
- **Multi Choice Gateway:** A Multi Choice Gateway is used when you must execute multiple transitions or flows based on the Decision Rule.

#### Note

If you use a Parallel or Multi Choice Gateway in your pipeline, ensure that after all the activities are added to these gateways, they are merged or closed again with a Parallel or Multi Choice Gateway, respectively. If there is no more activity to be performed after the Parallel or Multi Choice Gateway, it is mandatory to add an empty service task activity. Otherwise, the status is not updated correctly and the next activity execution does not happen.

#### 17.6.2.2.1.1 Executing Parallel Tasks

A Parallel Gateway is used to execute multiple tasks in parallel. In the usual flow, tasks are executed sequentially.

Figure 17-15 Executing Parallel Tasks flow

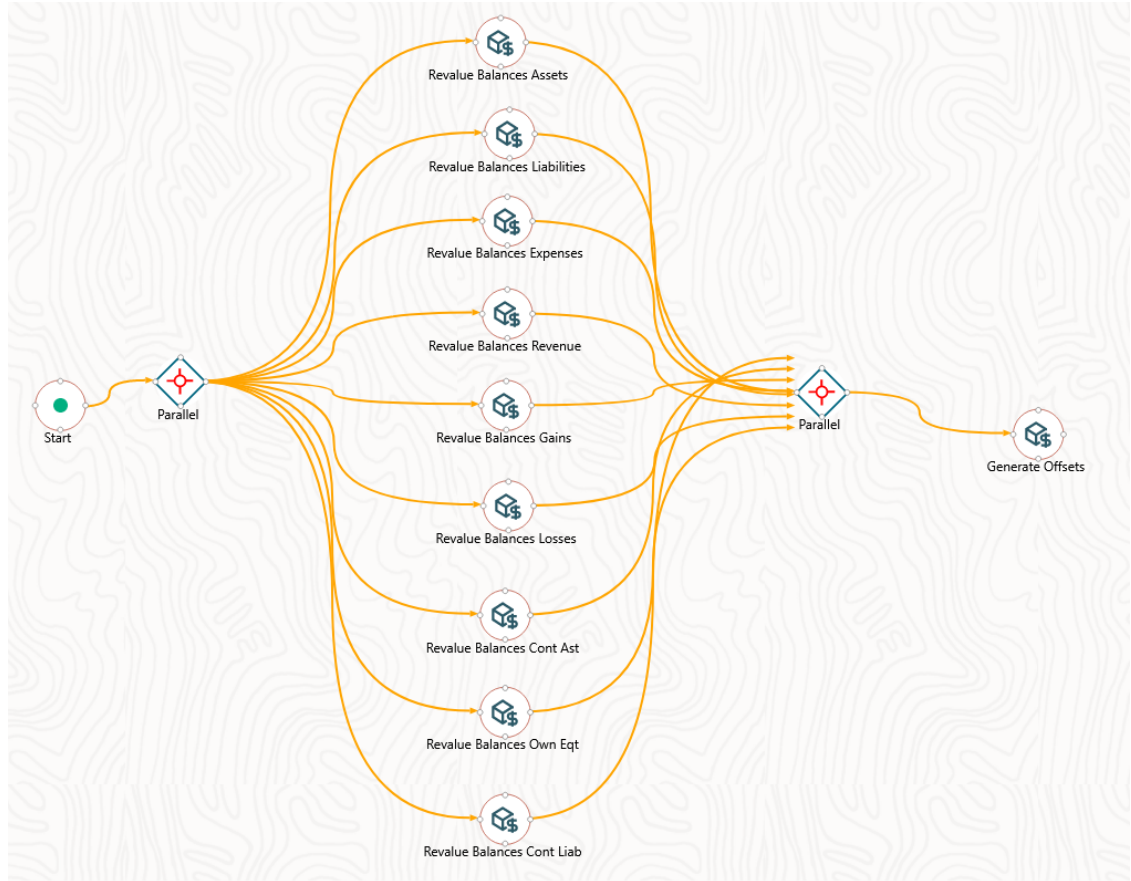

In the example shown, when the Parallel Gateway is invoked, all the OFSAA components that are placed between Parallel Gateways, are executed simultaneously. After all components are executed, the execution moves to the next activity in the Process Flow.

**Note**

In case if any one of the task fails as part of parallel gateway, the other ongoing parallel tasks executions are completed. The status of the activities get updated appropriately even though one or more activities fail.

Table 17-4 PMF Run Pipeline Design

Do's for a Gateway ( Parallel and Multichoice)	Dont's for a Gateway ( Parallel and Multichoice)
Ensure to begin and end with the same gateway during run pipeline design.	A parallel gateway cannot exist within another parallel gateway.
Ensure to add a service task if a parallel gateway is the last executing activity.	Multiple transitions are not supported for any activity in a run pipeline. Therefore, you must only use a parallel gateway.
Tasks which start from a parallel gateway must end in the successive closing parallel gateway.	

**Table 17-4 (Cont.) PMF Run Pipeline Design**

Do's for a Gateway ( Parallel and Multichoice)	Dont's for a Gateway ( Parallel and Multichoice)
Execution of a pipeline will begin from the <b>Start</b> activity. Therefore, the transition cannot be stopped for this activity.	

#### 17.6.2.2.1.1.1 How to Use Parallel Gateways

This section explains how to design parallel tasks using Parallel Gateways. For example, executing the Reconciliation widget in parallel for different rules.

1. Create a process in the Process Modeller canvas.
2. On the **Process Flow** page, you will see a **START** activity is already present on the canvas. This activity indicates the beginning of the process.
3. From the LHS menu, under **Transition**, click and drag a **Parallel Gateway** widget on to the canvas.
4. Connect the **START** activity with this **Parallel Gateway** widget.
5. Drag and drop the widgets representing the tasks that run in parallel on to the canvas. Example: add multiple Reconciliation widgets on to the canvas.
6. Connect the Parallel Gateway widget with each of these widgets representing tasks that must run in parallel. This represents the beginning of the transition.
7. Drag and drop another Parallel Gateway widget on to the canvas.
8. Connect each of the Reconciliation widgets to this newly added Parallel Gateway widget. This represents the end of the transition.
9. Configure the Reconciliation widgets based on your requirement.
10. Proceed in this manner to create your pipeline with one or multiple parallel tasks.
11. Click **Save**.

### 17.6.2.3 Connector

A Connector helps connect two activities with a different path (other than the default), in case the default path is overlapping an existing flow.

### 17.6.2.4 Widgets

Widgets are used to execute Connectors, DataService, and EventPosting.

#### 17.6.2.4.1 How to Use a Widget

1. Expand the toolbar on the left, click and drag the required widget icon under **Widget** on to the canvas.
2. Double-click the widget to open the configuration window for the widget. The **Activity** tab is selected.
3. Enter the **Activity Name** and **Activity Description**.
4. Specify the **Dynamic Parameters** for the widget. For more information, see the [Dynamic Parameters for Widgets](#) section.

### 17.6.2.4.1.1 Widget Configuration

- [RUN DQ RULE](#)
- [SCD](#)
- [HIERARCHYRESAVE](#)
- [Connectors](#)
- [DataService](#)
- [EventPosting](#)
- [BICCRetrieval](#)
- [Adjustment](#)
- [ExchangeRates](#)
- [DQReportingEngine](#)
- [Reconciliation](#)
- [BalanceComputation](#)
- [AmountTranslation](#)
- [Analytics Parent Child Relation](#)
- [Missing Master Loader](#)
- [File Watcher](#)

#### 17.6.2.4.1.1.1 SCD (Slowly Changing Dimensions)

##### Note

If you have entered the **Full Load** parameter as **YES**, you can load snapshot data for master tables and execute SCD process with additional parameters.

In case, when you have entered the **Full Load** parameter as **YES** and if the load is incremental and does not contain all the nodes, those nodes are retired by default.

When entered as **NO**, you can load incremental data for master tables and execute SCD process with additional parameters. The incremental data load for master tables is supported.

The retired dimensions can be brought back as part of subsequent SCD load by updating the Closed Flag column to null or 'N'.

**Note**

To enhance the performance of Slowly Changing Dimension execution process for high-volume data, a temporary processing table based on the processing with enhanced connection management has been implemented. The process is as follows:

1. The stage table volume for the given MISDATE is checked and if the data volume is above or equal to the configured threshold, then switch to MEDIUM connection.
2. By default, the SCD\_MED\_GRP\_EXEC\_THRESHOLD property is set to 30 million records. Users can configure the value of SCD\_MED\_GRP\_EXEC\_THRESHOLD entry in the AAI\_DMT\_CONFIG table in meta schema.
3. It is only applicable to SCD executions through PMF Orchestration Engine.
4. If an error occurs during this process of fetching the MEDIUM connection, then the connection falls back to low connection (i.e. default execution flow).

Current behavior of Disabled Nodes:

- The Closed Flag attribute is not supported for the Product Processor (PP) accounts.
- A new node in the Stage Master table with Closed Flag 'Y' is supported and will be ignored during SCD load.

To configure this widget, complete the following steps:

1. On the **Process Flow** page, from the LHS menu, expand **Widget** and drag and drop this widget on to the canvas.
2. Double-click the widget on the canvas. The configuration window is displayed with the **Activity** tab selected.
3. Under **Dynamic Parameters**, configure the settings described in the following table.
4. Click the tick mark icon to save your changes. To close the configuration window, click anywhere outside the window on the canvas.

**Table 17-5 Dynamic Parameters for SCD Description**

Property	Description
Datstore Name	Refers to the name of the Information Domain. By default, the Information Domain to which you are connected is selected.
Name	Select the name of the required dimension table.
Full Load	No input required.
Execution Venue	No input required.
Effective Date	No input required.

#### 17.6.2.4.1.1.2 RUN DQ RULE

To configure this widget, complete the following steps:

1. On the **Process Flow** page, from the LHS menu, expand **Widget** and drag and drop this widget on to the canvas.
2. Double-click the widget on the canvas. The configuration window is displayed with the **Activity** tab selected.

3. Under **Dynamic Parameters**, configure the settings described in the following table.
4. Click the tick mark icon to save your changes. To close the configuration window, click anywhere outside the window on the canvas.

**Table 17-6 Dynamic Parameters for RUN DQ RULE Description**

Property	Description
Datastore Name	Refers to the name of the Information Domain. By default, the Information Domain to which you are connected is selected.
DQ Group Name	Select the required DQ group.
Rejection Threshold	Enter the maximum number of errors in absolute value that a Data File can have despite which the Data Load will be marked successful. This is part of the property specification for the load to table option.  When the erroneous record count exceeds the Rejection Threshold value, the data loading task will fail and the inserted values will be rolled back for that table.  Inserts for the previous tables will not be reverted. Rejection Threshold will be applied to each of the target tables individually in a batch.

**Note**

The Rejection Threshold value should be a number which is considered as percentage of records. For example, if you have entered the value as 10, it is considered as 10 % of the entire records.

**Note**

The Threshold limit is not applicable for duplicate Data Quality Check.

By default, the **Rejection Threshold** is considered as **100** when no input is added.

When the Rejection Threshold is set as 100 or blank, the whole data file will be loaded irrespective of the number of errors.

**Table 17-6 (Cont.) Dynamic Parameters for RUN DQ RULE Description**

Property	Description
Additional Parameters	<p>Enter any additional parameters for the Run DQ Rule filtering criteria for execution in the pattern: Key#Data type#Value; Key#Data type#Value; and so on.</p> <p><b>NOTE:</b> In case these additional parameters are not specified, the default value is taken as NULL. Except the standard place holders \$MISDATE and \$RUNSKEY, all additional parameters for DQ execution should be mentioned in single quotes. For example, STG_EMPLOYEE.EMP_CODE = '\$EMPCODE'.</p>
Fail if Threshold Breaches	<p>By default, the <b>Fail If Threshold Breaches</b> is considered as <b>TRUE</b> when no input is added.</p> <p>When threshold breaches and the <b>Fail If Threshold Breaches</b> field is set to <b>TRUE</b>, the job will abort and the failure records are not inserted in the DQ Result tables.</p> <p>When threshold breaches and the <b>Fail If Threshold Breaches</b> is set to <b>FALSE</b>, the job will proceed further and the failure records will be inserted in the DQ Result tables.</p>
Stop Insert on Threshold Breach	<p>This is applicable only when <b>Fail if Threshold Breaches</b> is set to <b>FALSE</b>. When <b>Stop Insert on Threshold Breach</b> is set to <b>Y</b>, only the invalid records based on rejection threshold are inserted in the DQ Result tables. If set to <b>N</b>, all the invalid records are inserted. By default, it is set to <b>N</b>.</p>
Rule Exec Connection	<p>To establish a connection for DQ execution, enter the Rule Execution Connection as <b>STAGE</b>.</p>
Result Store Connection	<p>To store the Data Quality execution results, enter the Result Store Connection as <b>PREPROCESS</b>.</p>
Batch on Fail	<p>Leave this parameter blank.</p>
Micro service Id	<p>Enter the Micro Service ID.</p>

#### 17.6.2.4.1.1.3 Resave Hierarchies

To configure this widget, complete the following steps:

1. On the **Process Flow** page, from the LHS menu, expand **Widget** and drag and drop this widget on to the canvas.
2. Double-click the widget on the canvas. The configuration window is displayed with the **Activity** tab selected.
3. Under **Dynamic Parameters**, configure the settings described in the following table.
4. Click the tick mark icon to save your changes. To close the configuration window, click anywhere outside the window on the canvas.

**Table 17-7 Dynamic Parameters for HIERARCHYRESAVE**

Property	Description
Entity	Select one or multiple entities. Use the <b>Include all</b> or <b>Exclude all</b> icons to include or exclude all the entities respectively.
Hierarchy	Select one or multiple hierarchies. Use the <b>Include all</b> or <b>Exclude all</b> icons to include or exclude all the hierarchies respectively.
Load type	Select the Load Type: <ul style="list-style-type: none"> <li>Resave - Existing data is replaced with the freshly populated data.</li> <li>Refresh - Freshly populated data is added to the existing data.</li> </ul>

#### 17.6.2.4.1.1.4 Connectors

To configure this widget, complete the following steps:

1. On the **Process Flow** page, from the LHS menu, expand **Widget** and drag and drop this widget on to the canvas.
2. Double-click the widget on the canvas. The configuration window is displayed with the **Activity** tab selected.
3. Under **Dynamic Parameters**, configure the settings described in the following table.
4. Click the tick mark icon to save your changes. To close the configuration window, click anywhere outside the window on the canvas.

**Table 17-8 Dynamic Parameters for Connectors**

Property	Description
Connector Name	Select the required Dimension Columns from the drop-down list. The selected dimension column loads the data as mapped in the staging tables of the ledger into AFCS.
Variables	Enter the required variables. Add multiple variables using a comma separator.

#### 17.6.2.4.1.1.5 DataService

To configure this widget, complete the following steps:

1. On the **Process Flow** page, from the LHS menu, expand **Widget** and drag and drop this widget on to the canvas.
2. Double-click the widget on the canvas. The configuration window is displayed with the **Activity** tab selected.
3. Under **Dynamic Parameters**, configure the settings described in the following table.
4. Click the tick mark icon to save your changes. To close the configuration window, click anywhere outside the window on the canvas.

**Table 17-9 Dynamic Parameters for DataService**

Property	Description
Variables	Enter the required variables.
DataService Name	Select the required Data Service from the drop-down list.

## 17.6.2.4.1.1.6 EventPosting

To configure this widget, complete the following steps:

1. On the **Process Flow** page, from the LHS menu, expand **Widget** and drag and drop this widget on to the canvas.
2. Double-click the widget on the canvas. The configuration window is displayed with the **Activity** tab selected.
3. Under **Dynamic Parameters**, configure the settings described in the following table.
4. Click the tick mark icon to save your changes. To close the configuration window, click anywhere outside the window on the canvas.

**Table 17-10 Dynamic Parameters for EventPosting**

Property	Description
Subledger Application	Select the required Subledger Application from the drop-down list.

## 17.6.2.4.1.1.7 BICCRetrieval

To configure this widget, complete the following steps:

1. On the **Process Flow** page, from the LHS menu, expand **Widget** and drag and drop this widget on to the canvas.
2. Double-click the widget on the canvas. The configuration window is displayed with the **Activity** tab selected.
3. Under **Dynamic Parameters**, configure the settings described in the following table.
4. Click the tick mark icon to save your changes. To close the configuration window, click anywhere outside the window on the canvas.

**Table 17-11 Dynamic Parameters for BICCRetrieval**

Property	Description
Extract Type	Select the required BICC extract type to load from the options in the drop-down list.  Oracle Business Intelligence Cloud Connector (BICC) extracts business intelligence and other data in bulk and loads it into designated external storage areas.

## 17.6.2.4.1.1.8 Adjustment

To configure this widget, complete the following steps:

1. On the **Process Flow** page, from the LHS menu, expand **Widget** and drag and drop this widget on to the canvas.

2. Double-click the widget on the canvas. The configuration window is displayed with the **Activity** tab selected.
3. Under **Dynamic Parameters**, configure the settings described in the following table.
4. Click the tick mark icon to save your changes. To close the configuration window, click anywhere outside the window on the canvas.

**Table 17-12 Dynamic Parameters for Adjustment**

Property	Description
Adjustment Rule	Enter the Adjustment Rule name.

## 17.6.2.4.1.1.9 ExchangeRates

To configure this widget, complete the following steps:

1. On the **Process Flow** page, from the LHS menu, expand **Widget** and drag and drop this widget on to the canvas.
2. Double-click the widget on the canvas. The configuration window is displayed with the **Activity** tab selected.
3. Under **Dynamic Parameters**, configure the settings described in the following table.
4. Click the tick mark icon to save your changes. To close the configuration window, click anywhere outside the window on the canvas.

**Table 17-13 Dynamic Parameters for ExchangeRates**

Property	Description
Exchange Rates Rule	Enter the exchange rates rule to apply to the transaction or set of data. The rule computes the rate to convert the value from one currency to another.

## 17.6.2.4.1.1.10 DQReportingEngine

To configure this widget, complete the following steps:

1. On the **Process Flow** page, from the LHS menu, expand **Widget** and drag and drop this widget on to the canvas.
2. Double-click the widget on the canvas. The configuration window is displayed with the **Activity** tab selected.
3. Under **Dynamic Parameters**, configure the settings described in the following table.
4. Click the tick mark icon to save your changes. To close the configuration window, click anywhere outside the window on the canvas.

**Table 17-14 Dynamic Parameters for DQReportingEngine**

Property	Description
DQ Reporting Rule	Enter the DQ Reporting Rule that you wish to use for validation of the data.

**Note**

Post execution, you should perform a fresh execution from the PMF pipeline. It is not recommended to perform a re-run operation once the execution is complete.

## 17.6.2.4.1.1.11 Reconciliation

To configure this widget, complete the following steps:

1. On the **Process Flow** page, from the LHS menu, expand **Widget** and drag and drop this widget on to the canvas.
2. Double-click the widget on the canvas. The configuration window is displayed with the **Activity** tab selected.
3. Under **Dynamic Parameters**, configure the settings described in the following table.
4. Click the tick mark icon to save your changes. To close the configuration window, click anywhere outside the window on the canvas.

**Table 17-15 Dynamic Parameters for Reconciliation**

Property	Description
Rule Name	Enter the Rule Name that you want the use to reconcile the transactions and generate statements.

## 17.6.2.4.1.1.12 BalanceComputation

To configure this widget, complete the following steps:

1. On the **Process Flow** page, from the LHS menu, expand **Widget** and drag and drop this widget on to the canvas.
2. Double-click the widget on the canvas. The configuration window is displayed with the **Activity** tab selected.
3. Under **Dynamic Parameters**, configure the settings described in the following table.
4. Click the tick mark icon to save your changes. To close the configuration window, click anywhere outside the window on the canvas.

**Table 17-16 Dynamic Parameters for BalanceComputation**

Property	Description
Process Type	Enter the required process type. Example: Run Pipeline.
GL Type	Enter the required General Ledger Type to consider during balance computation.

## 17.6.2.4.1.1.13 AmountTranslation

To configure this widget, complete the following steps:

1. On the **Process Flow** page, from the LHS menu, expand **Widget** and drag and drop this widget on to the canvas.
2. Double-click the widget on the canvas. The configuration window is displayed with the **Activity** tab selected.
3. Under **Dynamic Parameters**, configure the settings described in the following table.

- Click the tick mark icon to save your changes. To close the configuration window, click anywhere outside the window on the canvas.

**Table 17-17 Dynamic Parameters for AmountTranslation**

Property	Description
Comments	Enter a description for the amount balance.

#### 17.6.2.4.1.1.14 OBIEEPCRelation

To configure this widget, complete the following steps:

- On the **Process Flow** page, from the LHS menu, expand **Widget** and drag and drop this widget on to the canvas.
- Double-click the widget on the canvas. The configuration window is displayed with the **Activity** tab selected.
- Under **Dynamic Parameters**, configure the settings described in the following table.
- Click the tick mark icon to save your changes. To close the configuration window, click anywhere outside the window on the canvas.

**Table 17-18 OBIEEPCRelation Widget Parameter Descriptions**

Property	Description
Dimension Hierarchy Entity	Select the required dimension hierarchy from the drop-down list.

#### 17.6.2.4.1.1.15 Missing Master Loader

- A new widget named **Missing Master Loader** is now available in the PMF screen under **Data Foundation** App package ID.
- This widget can be appended with the existing custom PMF runs or it can be set as a separate PMF run.

To configure this widget, complete the following steps:

- On the **Process Flow** page, from the LHS menu, expand **Widget** and drag and drop this widget on to the canvas.

#### 17.6.2.4.1.1.16 File Watcher

The File Watcher widget (or component) in the Process Modelling Framework is designed to monitor Oracle Object Storage for files that match a predefined pattern (previously known). Once a matching file is detected, it can automatically trigger subsequent tasks, enabling smoother integrations and supporting event-driven process automation.

There are two types of File Watcher widgets:

- Polling Based:** A polling-based File Watcher periodically checks Oracle Object Storage at defined intervals to detect the presence of a new or an updated file.
- Event Based:** An event-based File Watcher leverages Oracle Object Storage events to receive near real-time notifications when files are added, modified, or deleted.
- If the file is detected within the specified waiting period, the activity is marked as **Success**, and the pipeline proceeds to the next step in execution.
- If the file is not detected within the specified waiting period, the activity is marked as **Failed**, and the pipeline flow stops at failure.

- If the file detection is still in progress within the specified waiting period, the activity is marked as **In progress**.

This widget can monitor only one file at a time and if multiple files are to be detected, users must configure separate instances of the File Watcher.

To configure this widget, complete the following steps:

1. On the **Process Flow** page, from the Start node, click the **Add** icon, expand **Widget** and select this widget.
2. Double-click the widget on the canvas. The configuration window is displayed with the **Activity** tab selected.
3. Under **Dynamic Parameters**, configure the settings described in the following table.
4. Click **Save** to save your changes. To close the configuration window, click anywhere outside the window on the canvas.

**Table 17-19 Dynamic Parameters for File Watcher**

Property	Description
Type	Select any one of the File watcher type: <ul style="list-style-type: none"> <li>• Polling- Select this type to periodically check the Oracle Object Storage at defined intervals to detect the presence of new or updated files.</li> <li>• Event- Select this type for the Oracle Object Storage events to receive near real-time notifications when files are added, modified, or deleted.</li> </ul>
File Name	Enter the name of the file that you wish to search in the Object Storage.
Maximum Waiting Period (minutes)	It is mandatory to enter the waiting period until which the file must be detected in the object storage location.
Rename File (s)	Select any one of the options: <ul style="list-style-type: none"> <li>• True- Renames the file after detection and deletes the original file.</li> <li>• False- Retains the original file name.</li> </ul> This option is only supported for files lesser than 1 MB in size.
Bucket name	Enter the object storage information where the file must be detected.

## 17.6.3 Design a Pipeline

In AFCS, pipelines are used to design and execute the sequence of tasks, either AFCS tasks or external tasks, to derive a well-defined outcome. This flow is defined by using various AFCS components available in the component toolbar.

Using the Process Modeller, you can orchestrate a Run Pipeline using Process Orchestration Modelling.

### 17.6.3.1 Run Pipeline

A Run Process is used to create a Run Definition in the Rule Run Framework (RRF). A Run Pipeline is the visual representation of the Run enabled through Process Orchestration.

## An Example of Run Pipeline

Figure 17-16 Run Pipeline Example

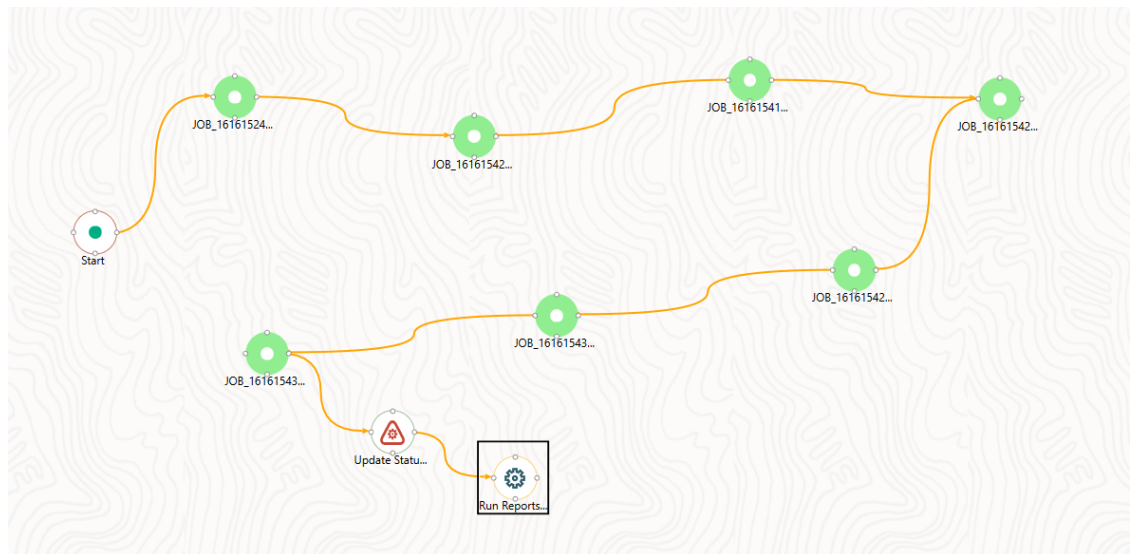

### 17.6.3.1.1 Creating a Run Pipeline

1. Click the **Add** button in the **Process Modeller Summary** page.
2. Enter a **Process Name** and **Process Description**. The **Process ID** is a unique system-generated value.
3. Select the appropriate package from the **App Package ID** drop-down.
4. Select **Run Pipeline** from the **Type** drop-down list.
5. Select the service that you want to connect to from the **Service ID Workspace** drop-down list.  
The list displays all the services that are mapped to the AFCS Service.
6. Click the **Accept** icon to save the entered details.  
The Process Flow canvas is displayed.
7. By default, the **START** activity appears on the canvas indicating the beginning of the process.
8. Drag and drop components from the toolbar on the left. You can drag and drop service tasks, gateways, connectors, and widgets on the canvas.
9. To connect one component with another, right-click the source component and choose **Start Link**. Next, click on the destination component and click **End Link**. Alternatively, if you drag and drop a component on another component on the canvas, the two components will be linked.
10. Proceed to link all the components per your requirement.
11. Click **Save**.

### 17.6.3.1.2 Creating and Executing a Custom DQ Run Pipeline

1. Click the **Add** button in the **Process Modeller Summary** page.
2. Enter a **Process Name** and **Process Description**. The **Process ID** is a unique system-generated value.
3. Select the **App Package ID** as **Data Foundation** from the drop-down.
4. Select **Run Pipeline** from the **Type** drop-down list.
5. Select the service that you want to connect to from the **Service ID Workspace** drop-down list.  
  
The list displays all the services that are mapped to the AFCS Service.
6. Click the **Tick mark** icon to save the entered details.  
  
The Process Flow canvas is displayed.
7. By default, the **START** activity appears on the canvas indicating the beginning of the process.
8. Drag and drop the **RUN DQ Rule** process widget.
9. To connect one component with an other, right-click the source component and choose **Start Link**. Next, click on the destination component and click **End Link**. Alternatively, if you drag and drop a component on another component on the canvas, the two components will be linked.
10. Proceed to link all the components per your requirement.
11. Double click the **RUN DQ Rule** process widget to enter the details. For more information on the parameters, see [RUN DQ RULE](#) section.
12. Click **Save**.
13. Execute the Custom DQ Run Pipeline. For more details on how to execute a pipeline, see [Executing a Pipeline](#) .

### 17.6.3.2 Additional Functionalities

This section describes how to manage pipelines including tasks such as viewing, modifying, copying, or deleting pipelines.

#### 17.6.3.2.1 Modifying a Pipeline

This option enables you to modify a pipeline. To modify a pipeline, complete the following steps:

1. On the **Process Modeller** window, search for the pipeline and click the pipeline name. The **Process Flow** tab is displayed.
2. Modify the process flow, definition, application rules, or data fields as required.

#### 17.6.3.2.2 Viewing a Pipeline

Use this option to view the workflow of an existing business process.

From the **Process Modeller** window, click the more information icon (the three vertical dots icon) to view the sub-menu and select **View**. The Process Flow of the selected pipeline is displayed.

### 17.6.3.2.3 Copying a Pipeline

Use the copy option to quickly create a new business process based on an existing process by updating the process flow or other required details.

To copy a business process, complete the following steps:

1. From the **Process Modeller** window, click the more information icon (the three vertical dots icon) to view the sub-menu of the selected pipeline and select **Copy**.
2. In the **Process Details** window, enter a unique **Process ID**, **Process Name**, and **Process Description**. If you select the same **App Package ID**, then **Data Fields** and **Application Rules** are also copied.
3. Click **Save**.

### 17.6.3.2.4 Deleting a Pipeline

Use this to delete a Business Pipeline or Run Pipeline.

To delete a pipeline, complete the following steps:

1. From the **Process Modeller** window, click the delete icon corresponding to the pipeline you want to delete.
2. A confirmation window is displayed. If you wish to delete the process, click **Confirm**.

## 17.6.4 Data Fields

Data Field, also known as a process variable, enables Process Pipelines access and store information from external sources. Often, the process flow is based on the value of this information. In other cases, this information is the result of running tasks in the pipeline.

### 17.6.4.1 Add a Data Field

1. On the **Process Modeller** page, click the pipeline to which you want to add a Data Field.
2. Select **DataFields** from the header to display the **Data Fields** window.
3. Click the + icon to display the **Addition of Data Field** window.
4. Provide the details described in the following table and click the tick mark icon to save the details:

**Table 17-20 Data Field Details Description**

Field Name	Description
Data Field Code	Enter the Variable Name/Code, which will be used to read or write into this variable. This field is non-translatable.
Data Field Description	Enter a brief description.
Data Field Type	Select the Data Field Type.
Initial Value	Enter the initial value for the data.

**Table 17-20 (Cont.) Data Field Details Description**

Field Name	Description
Is Mandatory	Applies to the <b>AOM</b> Data Field Type. <b>Yes</b> is the default selection for AOM. Select <b>No</b> if you do not want this parameter to be displayed as Execution Parameter for the Run pipeline.
Scope	Select the scope of the Data Field. Options are: <ul style="list-style-type: none"> <li>• <b>Process</b> - To use the Data Field only in the current process.</li> <li>• <b>Package</b> - To use the Data Field across all the processes in the package.</li> </ul>

## 17.6.4.2 System Data Fields

Some data is tracked internally by AFCS using a predefined set of Data Fields such as Status. You can access these activity instance attributes in the same way you access Regular Data Objects, but you cannot assign them new values.

## 17.6.5 Executing Run Pipeline

After creating your Run pipeline, your next step is to execute it. To execute a Run pipeline, complete the following steps:

1. From the **Process Modeller Summary** page, click the menu button corresponding to Run pipeline you want to execute and select **Execute Run**.
2. The **Execution** window is displayed.
3. Select the **Execution Type**, **Object ID**, and **Application Params (in JSON format)** and click **Execute**.

The execution is triggered using the selected FIC MIS DATE. The RUNSKEY is generated and inserted into the "DIM\_RUN" table. For the RUNSKEY generated, the corresponding user-selected parameters are inserted into the "RUN\_EXE\_PARAMETERS" table.

You can use the Process Flow Monitor to view the status of the execution as the Run pipeline is executed.

## 17.6.6 PMF Dashboard

When there are multiple pipelines running in parallel, monitoring the processes to find out if they have executed successfully or otherwise, information about the tasks within pipelines that have completed, failed, canceled, and in-progress yet becomes important.

The Process Modeling Framework (PMF) Dashboard displays granular level execution details of all PMF processes belonging to Loader components and Data Quality executions within a environment (tenancy). Only authorized users belonging to the Accounting Foundation Admin Group or Accounting Foundation Operations User Group will have access to the PMF Dashboard. For each PMF process, these authorized users can drill down and view the related activities and further into the events recorded for each activity along with information such as the timestamp, event messages, and event error codes. This information aids you to gauge the progress made by each task. You also have the option to monitor a pipeline and view it on the PMF canvas.

Navigation to the PMF Dashboard page is through the PMF Dashboard icon on the Process Modeller page. On the dashboard page, you can view detailed information about the processes that have run and the details of the events (activities) that have occurred during the execution of the tasks.

You have options to filter the activities and tasks: for example, completion status, Process ID, or execution date. You can also export the results as a report to an Excel or CSV format.

### 17.6.6.1 View and Filter PMF Dashboard

The PMF Dashboard displays detailed, drill-down information about the processes that have run and the details of the events (activities) that have occurred during the execution of the tasks. You can use the filters provided to quickly search and locate a PMF Process that has run regardless of whether process completed or failed.

#### Note

The PMF Dashboard supports wildcard search where you can search for objects without having to provide the complete activity name, process name, or instance ID. In addition, the search feature is case-agnostic; you can type the search strings in upper or lower case.

To view and filter the PMF Dashboard:

1. From the **AFCS Home** page, select **Process Orchestration**.

The **Process Modeller** page is displayed.

2. Click the **PMF Dashboard** icon on the header. The **PMF Dashboard** page appears and displays the PMF processes that have run.
3. You can filter the PMF dashboard to quickly search for a PMF process you are interested in. Note that the search is case-sensitive. The following filter options are available:
  - **Process Status:** Select one or multiple statuses to filter the PMF dashboard. For example: to see all processes that have failed, click **Process Status** under the search bar and select **Failed** to view a list of all the processes that have failed.
  - **Process Name:** Enter the process name.
  - **Process ID:** Enter the process ID.
  - **Process Instance ID:** Enter the process Instance ID.
  - **More Filters:** Select from one of the multiple options available.
  - **Execution Date:** Select a time period or a date range based on the time zone in which the user is logged in.

The dashboard is refreshed and the PMF process(es) matching your filter criteria are displayed.

4. You can drill-down each PMF process to view the activities (tasks) that have been defined for that process. Use the additional filters to filter activities based on **Activity**, **Event Parameters**, **Event Message**, and **Event Error Code**. To apply a filter, click inside the search bar, select the filter, and press Enter.
5. Each PMF process has the following information:
  - **Process Instance ID:** The unique system-generated value that identifies the process instance.

- **Data Source ID:** The Data Source ID of the process.
  - **Run Params:** The input parameters provided to execute this process.
  - **As Of Date:** The As of date.
  - **Run Skey:** The unique number created for each instance.
  - **Start Time:** Start time of the process execution.
  - **End Time:** End time of the process execution.
  - **Duration:** Duration of the process execution.
  - **Status:** Indicates if the process has completed, failed, was canceled, or is still running.
  - **Monitor:** Click this icon to view the progress of this process on the PMF canvas.
6. Click the PMF process link to drill down and display the activities associated with this process. The associated activities (for example: SCD, Connectors, Run DQ Rule, and so on) are displayed. For each activity, the following information is available:
    - **Component:** The component type.
    - **Start Time:** Start time of the activity execution.
    - **End Time:** End time of the activity execution.
    - **Duration:** Duration of the activity execution.
    - **Status:** Indicates if the activity has completed, failed, was canceled, or is still running.
  7. Click the activity name link to drill down further and view details of the events within this activity. For example: if the activity is an **Insert Connector**, the following event information is displayed:
    - **Timestamp:** The latest record is displayed on top.
    - **Number of error records:** The number of error records.
    - **Event:** The event that is being recorded.
    - **Number of records loaded:** The number of records that were loaded.
    - **Event message:** Status of the event completion.

## 17.6.6.2 Exporting PMF Dashboard Report

You can also export the PMF dashboard contents as a report in Excel or CSV formats. Here again you have options to filter the data that is exported.

To export contents of the PMF Dashboard into a report:

1. On the **PMF Dashboard** page, use the filters to select the PMF process(es) and the activities within the PMF process(es) you are interested in.
2. Click **Export**.
3. Choose the format for your report (Excel or CSV).
4. You need to apply at least one filter criteria to export the report as there is a limit to the number of records you can export. To filter the contents to export to your report, click the **With Filter** option and select the filter criteria from the search box.
5. Click **Export** and save the report file to a local directory. The report will contain details of the selected process(es), activities within the process, and the tasks within the events.

**Note**

The export file can contain a maximum of 6500 records (rows) only. Hence it is recommended to use at least one filter when exporting the contents of the Dashboard to a report.

### 17.6.6.3 PMF- Error Codes and Descriptions

The PMF Error codes are categorized as follows:

- **WARNING** - Anything that can potentially cause application oddities, but for which the application can automatically recover.
- **ERROR** - Any error which is fatal to the operation, but not the service or application (can't open a required file, missing data, etc.). For example, an error can be used in a scenario where a PMF activity perform 10 sub operations, out of which one failed and other 9 and over all activity is succeeded.
- **FATAL** - Any error that is forcing a failure of a PMF activity can be FATAL.
- **FATAL-AUTOMATED** - If the component is not sending any FATAL to PMF, the PMF will auto-generate a fatal message "Automated: <Activity ID> is Failed".

COMP	CATEGORY	EVENT CODE	EVENT DESC
DQ	FATAL	DQ_ERR_001	Threshold is breached
DQ	FATAL	DQ_ERR_002	DQ Execution Failed
DQ	FATAL	DQ_ERR_003	Invalid Input Message
DQ	FATAL	DQ_ERR_004	DQ Group is unauthorized
DQ	FATAL	DQ_ERR_005	Rules/Groups could not be registered with Concurrency
DQ	FATAL	DQ_ERR_006	Unknown Error Encountered
DT	FATAL	DT_ERR_002	DT Execution failed with Validation error
DT	FATAL	DT_ERR_001	DT Execution failed
DT	FATAL	DT_ERR_003	Exception occurred while Executing DT
HCY	FATAL	HCY_ERR_001	Hierarchy Refresh Execution failed
HCY	FATAL	HCY_ERR_002	Hierarchy Resave Execution failed
HCY	ERROR	HCY_ERR_003	Hierarchy Refresh Partially Successful
HCY	ERROR	HCY_ERR_004	Hierarchy Resave Partially Successful
HCY	FATAL	HCY_ERR_005	Unexpected Exception Occured
SCD	FATAL	SCD_ERR_002	SCD Execution failed with Validation error
SCD	FATAL	SCD_ERR_003	Exception occurred while Executing SCD
SCD	FATAL	SCD_ERR_001	SCD Execution failed

## 17.6.7 PMF Email Notification

Use this feature to configure the email notifications for package/process or user level.

The PMF Email Notification page enables you to send Email notifications for indicating the status (completion or failure) of a PMF process. This will permit pushed notification of users via email with failure/completion status for taking timely and necessary actions.

### 17.6.7.1 PMF Email Notification at Package or Process Level

Use this feature to set Email notification at package/process level.

To set the PMF Email notification at Package/Process level:

1. From the **AFCS Home** page, select **Process Orchestration**.  
The **Process Modeller** page is displayed.
2. Click the **PMF Email** icon on the header. The **PMF Email Notification** page appears and displays the Package and Process Level email notifications.  
You must be mapped to AFCSADMNGRP user group to view the PMF Email icon on the header.
3. Click the plus icon and select the Package radio button and the package IDs for which the email notifications has to triggered.
4. Click Apply.  
The selected packages are displayed.
5. Click Add User and select the User or User Group to whom the email notifications to be shared.  
You should add users at package level and not at the process level.
6. Click Apply and Save.

### 17.6.7.2 PMF Email Notification at User Level

Use this feature to set Email notification at user level.

To set the PMF Email notification at User level:

1. From the **AFCS Home** page, select **Process Orchestration**.  
The **Process Modeller** page is displayed.
2. Click the **PMF Email** icon on the header. The **PMF Email Notification** page appears and displays the Package and Process Level email notifications.
3. Click the plus icon and select the User/User Group radio button and the users or groups to receive the email notifications.  
You should add users at package level and not at the process level.
4. Click Apply.  
The selected User/User Groups are displayed.
5. Click Add Package and select the Package or Process for which the email notifications has to triggered
6. Click Apply and Save.

### 17.6.7.3 PMF Email Notification Template

Use this page to configure the email notification messages for package/process or user level.

To configure the PMF Email notification messages:

1. From the **AFCS Home** page, select **Process Orchestration**.

The **Process Modeller** page is displayed.

2. Click the **PMF Email** icon on the header. The **PMF Email Notification** page appears and displays the Package and Process Level email notifications.

You must be mapped to AFCSADMNGRP user group to view the PMF Email icon on the header.

3. Click **Template** option next to Email Notification at the bottom of the page.

The Email Notification template is displayed. By default, the following variables are added to the message body:

- Tenant-Id
- Run-Sk
- Process-Id
- Object-Id
- Task-Status
- As-Of-Date
- Entity-Name
- Process-End-Time
- Entity-Id
- Title
- locale
- Process-Start-Time
- Entity-Type
- Process-Name
- Process-Instance-Id
- Received-On

4. You can remove the variables from the Template body to be displayed in the email based on your requirements.

The Template you configure is at global level and not at the user group or package/process level.

#### Note

Forwarding the email will send all the parameters available and do not retain the template.

## 17.6.8 Process Monitor

Use the Process Monitor to monitor the current stage of a process. After integrating with a service, a workflow is invoked. After it is invoked, the workflow goes through all the defined stages. Using the Process Monitor, you can view all the stages of the workflow such as current stages, stages to follow, if any, and finished.

Your User Group must be mapped to the Function Role WFMAcc (Workflow Monitor Access) to access the Process Monitor.

On the **Process Modeller** page, click the Process Monitor icon on the header to view the Process Monitor page. All workflows that are invoked from the service are displayed along with details such as **Entity Name**, **Entity ID**, **Process Name**, **Process Description**, **MIS Date**, **Execution Start Time**, **Last Execution Time**, **Last Updated By**, and **Status**.

To monitor only a selected pipeline, on the Process Modeller summary page, click the menu button corresponding to that pipeline and select **Process Flow Monitor**. The execution details are displayed.

Click the menu button corresponding to the selected pipeline to view options to:

- Resume: To resume a Run pipeline.
- Re-run: To execute a Run pipeline again irrespective of the previous execution status.
- Abort: To abort an ongoing Run pipeline.

### Note

In case of Disaster recovery (DR) after switch over to the secondary site, the processes that are in running status should be aborted and resume to proceed further.

To return to the Process Modeller page, click the Process Modeller icon on the header of the Process Monitor page.

Use the **Search** field to search for a specific pipeline by providing a keyword from either the Process ID, Process Name, or Process Description of the process you are looking for and click **Search**.

### 17.6.8.1 Monitoring a Process

From the **Process Monitor** window, click the Entity ID link corresponding to the process you want to monitor.

The status of the activity is represented as: **Completed**, **Failed**, or **Running**.

You can also set auto-refresh in the header. Select **Enabled** in **Auto Refresh**, enter a value from 1 to 10 in **Refresh Interval (In Min)** and then click **Apply**.

### 17.6.8.2 Viewing Activity Execution Logs

Use this feature to view logs of the execution of each activity from the Process Monitor window.

To view Activity Execution Logs:

1. From the Process Monitor page, click the process which you want to monitor. The canvas displaying the workflow along with the status is displayed. On the canvas, double-click an activity to view the **Activity Execution** window. The activity details are displayed.
2. Click the **Execution Logs** button to view the Activity Execution Log.  
The Log Viewer window shows all the execution stages (successful and failed) of the selected activity if it is already executed.  
The **Batch Run ID** and **Process ID** fields show the information for the previously selected parameters in the activity configuration.

**Note**

Use the **Search** field to search within the execution log.

The information available is segregated in to sequence, timestamp, severity, and message. You can sort by Ascending or Descending Order by clicking the Up and Down Arrows in the Header Row.

- Sequence depicts the order of the log messages generated during execution.
- Timestamp shows the date and time of the generation of the log message.
- Severity shows labels such as Info to show the type of message, which helps determine if any intervention is required.
- Message displays the log message generated.

**Note**

The information in the Log Viewer window is specific to the selected Process Orchestration activity such as a widget or transition.

## 17.6.9 Abort Run Pipeline

You can abort a Run Pipeline that is in the process of execution.

To abort a Run pipeline, complete the following steps:

- From the **Process Monitor** window, click the menu icon corresponding to the Run pipeline that is being executed that you want to abort and click **Abort**.

## 17.6.10 Resume Run Pipeline

You can resume a Run Pipeline which has not been executed successfully or which has been explicitly interrupted, or canceled, or put on hold during the Execution process. By resuming a Run pipeline, you can continue its execution directly from the point of interruption or failure and complete executing the remaining tasks.

To resume a Run Pipeline

1. From the **Process Monitor** page, click the menu icon corresponding to the Run pipeline you want to resume and click **Resume**.
2. Enter comments if any, for restarting the Run Pipeline execution.

## 17.6.11 Re-run Run Pipeline

You can re-run a Run pipeline that was previously executed, irrespective of the previous execution state.

### Note

The re-run option should not be used with a new dataset for any process.

To re-run a Run pipeline, complete the following steps:

1. From the **Process Monitor** page, click the menu icon corresponding to the Run pipeline you want to re-run and click **Re-Run**.
2. Enter comments if any, for re-running the Run Pipeline execution.

## 17.7 Appendix- Application Rules

The Application or API Rule is the interface between the process engine and the application.

To access Application Rules, do as follows:

1. On the Home page, click **Process Orchestration**.
2. From the **Process Modeller** window, click the **Process ID** icon corresponding to the Pipeline for which you want to add an application rule. The Process Flow Canvas page is displayed.
3. Click the **Application Rules** icon and Application Rules Drawer window is displayed.
4. Click **Create** to add the application rule. The Application Rules window is displayed.

To delete an application rule:

- You can delete a rule by clicking the **Delete** button next to the rule.

### 17.7.1 Decision Rule

This rule returns the Boolean value “True/False”, used in decision making during split/branching of transition.

**Use Case of Month End Replication** - The requirement is to run the load connector only on the last business day of the month (which is not month-end) and when the MIS\_DATE is any other business day of the month, It should skip the task.

The expression rule of type decision is '{LAST\_BUS\_DAY}'='{FIC\_MIS\_DATE}' AND '{LAST\_BUS\_DAY}'< '{MONTH\_END\_DATE}'

The following application rules are supported:

- Expression Application Rule
- Attribute Expression Application Rule

#### 17.7.1.1 Expression Application Rule

You need to specify only the 'SQL query Where Clause' in the Expression field.

Figure 17-17 Expression Rule Details Window

The screenshot shows a web interface titled 'Application Rules' with a close button (X) in the top right corner. Below the title bar are two buttons: '< Back' and 'Create'. The main form contains several fields:

- Application Execution Type:** A dropdown menu with 'Expressions' selected.
- Name:** A text input field containing 'AFCS\_EXP\_S01'.
- Description:** A text input field containing 'Expression selection'.
- Rule Type:** A dropdown menu with 'Decision Rule' selected.
- Expression Type:** A dropdown menu with 'SQL' selected.
- Expressions:** A text input field containing the SQL expression '{WF\_TASK\_STATUS}'='SUCCESS'.
- Return Parameter:** A dropdown menu.
- Scope:** A dropdown menu with 'Process' selected.

Table 17-21 Expression Rule Details Description

Field Name	Description
Name	Enter a unique name for the Application Rule.
Description	Enter a description for the Application Rule.
Rule Type	Select the <b>Rule Type</b> from the drop-down list. The Expression Application Rule can be used as a Decision Rule, Execution Rule, or Selection Rule based on your requirement.
Expression Type	Select Expression Type as SQL to use SQL expressions
Expression	Enter the expression in SQL format. For example, '{WF_TASK_STATUS}'='SUCCESS'. The WF_TASK_STATUS is the Data Field name and the Data field value replaces the Data Field name in the expression present in the {}.
Return Parameter	<b>This is field optional.</b> Select the Data Field that receives the return parameter of the Expression, from the drop-down list.
Scope	Select the <b>Scope</b> as <b>Process</b> to use the Application Rule only in the current process or <b>Package</b> to use the Application Rule across all the processes in the package.

## 17.7.1.2 Attribute Expression Application Rule

**Figure 17-18 Attribute Builder Window**

**Table 17-22 Attribute Builder Description**

Field Name	Description
Name	Enter a unique name for the Application Rule.
Description	Enter a description for the Application Rule
Rule Type	Displays the rule type as Decision Rule. This Rule Execution type supports only the Decision Rule type.
Attribute	Select the attribute for which you want to define the application rule, from the drop-down list. The list displays the attributes configured for the selected application and component. The selected attributes will be displayed one after the other. You can select multiple attributes from the drop-down list. You can delete a row by clicking the <b>Delete</b> icon.

# 18

## Balance Computation

Balance Computation in AFCS supports assessment and maintenance of instrument-level accounting balance information. The following functions are also supported:

- Period to date (month, quarter and year to date) average values of instrument-level accounting balance
- Revaluation of instrument-level accounting balance
- Currency translation of instrument-level accounting balance as a part of the period balance

Derivation of instrument-level balance in Balance Computation is based on an initial GL or Subledger Balance (ledger balance) snapshot, and daily or periodic snapshots of corresponding journal entries (debits and credits). Ledger balance and journal entries may be ingested into Balance Computation functions from external sources.

### Note

AFCS Balance Computation tasks will not support processing filtered by or limited to Legal Entity runtime parameter. Such parameter will be retained in the user interface and API for a period not exceeding two forthcoming releases. This is solely to avoid disruptive changes to process configuration in existing service instances. Balance computation processes will be incremental and available for execution per ledger or for all ledgers.

### Note

In the AFCS Standard Edition, backward flow is not applicable and therefore Balance Computation is not supported. For more information, see the [About Accounting Foundation Cloud Service- Standard Edition](#).

## 18.1 Currency Exchange Rates

The Currency Exchange Rates entity offers the value of one currency in relation to another currency. This entity stores the list of all exchange rates for all currency types.

Data progresses through the following stages:

- Staging: Data is provided at the granularity level of a date or a period.
- Preparation: If data is provided for a period, that data is exploded (split) based on the individual date granularity.

### 18.1.1 About Currency Exchange Rates

Currency Exchange Rates Service consists of the following Conceptual Modules:

- Staging: In this Module, the Data is provided on a Date or a Period granularity level.

- Preparation: If the Data is provided for a Period, then that Data is exploded (split) based on the individual Date granularity.

## 18.1.2 Staging

Inputs to the data service can be provided at one of the following granularities:

- **Date:** Rates are provided at the Date granularity and can be as follows:
  - Average for the Day
  - Spot Rate
  - Start of the Period
  - End of the Period
- **Period:** Rates are provided for a period (effective start date and effective end date). This is typically used for internal computations to avoid currency rate fluctuations that affect incentive, pricing, estimates, budgets, and so on.

### 18.1.2.1 Currency Exchange Rates at Time Granularity

This section describes the Time Granularity level in Currency Exchange Rates.

- Time Granularity may include the following:
  - Beginning of the Day
  - Mid-day
  - End of the Day
  - Any time (running variable), for example, 11 A.M. Rates and 4 P.M. Rates.
- For each Time Granularity that has to be captured, a Data Version has to be created in the Data Version Dimension entity.
- Currency Exchange Rates are provided in Staging along with the data version information. For example, you can stamp the Currency Exchange Rates given for three days at 08:00, 08:01, 07:59 as the 'Beginning of the day'.

### 18.1.2.2 Currency Rate Type with Seeded List of Values

The Rate Type and its description are provided here.

- SOP and EOP (Start of the Period for the day and End of the Period for the day): Rate is provided with the time stamp.
- Average for the Day: Average for the day is provided by the source.

### 18.1.2.3 Currency Rate Nature with Seeded List of Values

The Rate nature and its description are described here.

- Floating (FLTG): This is the floating rate prevailing in the market.
- Fixed (FIXED): This is the rate fixed by the bank or regulator (for reporting) for a particular purpose. For example, pricing.
- Forecast: These are the rates forecast and provided by a cloud service.

## 18.1.3 Preparation

The details of the Preparation stage are described here.

Currency Exchange Rates provided at the Date Granularity are loaded directly into the processing entity.

Currency Exchange Rates provided for a period are exploded to a Date Granularity and loaded at the Date Granularity level.

After data is populated, if there are missing data points between all possible currency pairs for currencies that are active in the Currency Dimension Entity, data is populated using these methods:

- Inverse
- Triangulation

After data is populated, the Exchange Rate is available in time and date, and date granularity.

Data is flagged if it is arrived at using Inverse or Triangulation methods. This helps you recognize if the rate in use is traceable to a source.

## 18.1.4 Currency Exchange Rates Workflow

Exchange Rates are loaded for a version, As of Date, which holds the information related to the Legal Entity, Time Zone, Start Time and End Time, and Organization Unit.

The Stage Currency Exchange Rates is the Input Table in the Currency Exchange Rates Process. The types of Data accepted in the Input Table are as follows:

- As of Date
- Effective Start Date
- Effective End Date
- Source Currency
- Target Currency
- Currency Rate Type (Seeded List of Values are Spot Rate, Average for the Day, Start of the Period, and End of the Period)
- Currency Rate Nature (Seeded List of Values are Floating, Fixed, Forecast)
- Currency Rate Version
- Exchange Rate
- Data Source

To use the Currency Exchange Rates Data Services, do the following:

1. Create an Exchange Rates Pipeline using the following procedure:
  - a. Navigate to the Process Modeller Page. On the Home page, click **Process Orchestration**. The **Process Modeller** Page is displayed.
  - b. Click the **Add** Button. A **Process Flow** Page with the Process Details Page is displayed.
    - i. Enter Process Name and Process Description.

- ii. On the **App Package ID** list, select **Data Foundation**.
        - iii. Select the **Type** as **Run Pipeline**.
        - iv. Select **Oracle Financial Services Data Service for Analytics\_WS001** for the **Service ID\_Workspace**.
        - v. To save the changes, click the **Apply** Button.
      - c. On the **Process Flow Page**, to design the **Process Flow** on the **Drawing Canvas**, use a **Widget Component** available in the floating tool bar.
      - d. To load all the **Exchange Rates** into the **Stage Currency Exchange Rates Entity**, add a **Connector** to the **START**. For information about creating a **Connector**, see the [Ingesting Data into AFCS](#) section.
      - e. To connect the **START Node** with the **Connector**, right-click on the **START Node** and select **Start Link**, then right-click on the **Connector** and select **End Link**.
      - f. Drag an **ExchangeRates** **Widget** to the **Canvas**.
      - g. To connect the **Connector Node** with **ExchangeRates**, right-click on the **Connector** and select **Start Link**, then right-click on the **ExchangeRates** **Widget** and select **End Link**.
      - h. Click the **Save** Button.  
A **Confirmation Acknowledgment Message** is displayed: **Successfully saved**.
2. Execute the **Exchange Rates Pipeline** using the following procedure:
  - a. On the **Process Modeller Page**, click the **Menu** corresponding to the **Exchange Rates Pipeline**. Click **Execute Run**.  
The **Process Flow Page** with **Execution** is displayed.
  - b. Select the **Execution Type** as **With Parameters**. Select the required **As of Date** for which the **Exchange Rates** needs to be processed. Click the **Apply** Button to initiate the **Run Pipeline Execution**.
  - c. The **Exchange Rates Pipeline** loads the **Preparation Currency Exchange Rates Entity**.
  - d. To verify the **Execution Status**, on the **Process Modeller Page**, for the **Exchange Rates Pipeline**, click the **Menu** and select the **Process Flow Monitor**.  
The **Process Monitor Page** is displayed with the list of **Exchange Rates Process ID**. Select the **Process ID**. The **Process Flow Page** is displayed with the **Execution status** of the **Exchange Rates Pipeline**.

**Note**

By default, the number of failed records are saved in the **Execution Log** file. To view more details on the failed records, see [Data Visualization Reports](#).

**Note**

If the **Effective Start Date** and **Effective End Date** are mentioned in the **Stage Currency Exchange Rates Entity**, then the **Rate** is considered for a **Period**. Otherwise the **Effective Start Date** should be same as the **Effective End Date**.

**Note**

Execution of the Exchange Rates Pipeline Processes the Input Data from the Stage Currency Exchange Rates Element using the Triangulation or the Inverse Methods, and populates the Processing Entity. The Period Rates will be exploded for the complete Date Range.

1. If the Exchange Rates for a Period is present, then the Direct Rates are loaded for individual Rates for each Date.
2. If the Inverse for all the above Dates are not present in the Stage Currency Exchange Rates Entity, then the Inverse is calculated and loaded to Preparation Currency Exchange Rates Entity.
3. Triangulation for the Rates is done only if any Date intersection is present.

## 18.2 Currency Conversion

You can set up the Currency Conversion Settings to assign the Rate Type to a General Ledger (GL) Type Entity. For a computation, you can convert any transaction into different Currencies, which is called a Translation.

For each GL Type Entity, you can assign one of the following Rate Types:

- **Spot:** Use this to perform the Translation for an immediate instance.
- **Start of the Period:** Use this to perform the Translation for the Start of the Period.
- **End of the Period:** Use this to perform the Translation for the End of the Period.
- **Average:** Use this to perform the Translation on an Average Period.

You require these settings to use the Execution Process in the [Managing Processes](#).

To set up the Currency Conversion Settings, do the following:

1. To navigate to the Currency Conversion Settings, on the Home Page, click Administration, and click Currency Conversion. The Currency Conversion Settings Page is displayed. During the Deployment Process, User with the Admin Privileges can set up Currency Conversion Settings using the same procedure.
2. By default, the **Translation Required** is enabled. You can enable or disable based on your requirements. This will exclude/include a translation task from the balance computation process. If disabled, the below options are not displayed.
3. Select either the **End of Period, Daily, Average**, or Spot Rate Type Value for the following GL Type Entities:
  - Asset
  - Expense
  - Loss
  - Gains
  - Contra Asset
  - Contra Liability
  - Liability
  - Owners Equity

- Revenue
4. Click **Save**. The Currency Conversion Settings are saved.

## 18.3 Period to Date Balance

Period to Date Balance is computed and stored based on prior-period balance and cumulative effect of journals obtained from ERP Financials Cloud Service. Balance figures against General Ledger Accounts of type Balance Sheet are maintained as a running tally, whereas the balance figures against the GL Accounts of type P and L are reset every month based on the defined Fiscal Periods defined.

Period to Date Balance is a part of the Balance Computation Management Ledger Pipeline. For information about re-saving the BCE Hierarchies, and then using and executing the Pipeline, see the Sections [Resave Hierarchies](#) and [Use and Execute the Balance Computation Management Ledger Process](#) respectively.

## 18.4 Period to Date Average

Statistical Amounts (Average, Month-to-Date, Quarter-to-Date, and Year-to-Date) are derived off of the Instrument Level Accounting Balance information. Balance Computation uses Instrument Accounting Balance figures across multiple MIS Dates, Calendar Information, and Fiscal or Accounting Period Definition to assess the Average Accounting Balance, Month-to-Date Accounting Balance, and Year-to-Date Accounting Balance as the Statistical Management Ledger Amounts.

### Note

When the Backdated Journals are processed, the System recomputes the Daily Movements, Period-to-Date, and Period-to-Date Average Balances for the Range between the Journal Posting Date and the As of Date. Based on the preceding method, the larger the Range between the two Dates, the greater is the duration for Execution.

### Topic:

- [Resave Hierarchies](#)
- [Use and Execute the Balance Computation Management Ledger Process](#)

### 18.4.1 Use and Execute the Balance Computation Management Ledger Process

Use this Run Pipeline (Process) to compute the daily movements, Period-to-Date, backdated, and Translation Process Execution of average balances in Balance Computation. The Run Pipeline (Process) can be executed incrementally in a day based on user-chosen set of balance computation run time parameters, including a specific As-of-date. This will allow accounting balance information at management ledger grain to be refreshed multiple times within a given As-of-date.

**Note**

- When Balance Computation Management Ledger is executed, balances are computed for all unique Management Ledger segments from accounting entries present across all sources.
- More than one 'Balance Computation Management Ledger' process should not be simultaneously executed with the same set of runtime parameters. Please note that considering the treatment of Data Source runtime parameter noted above, runtime parameters other than Data Source should be different before two 'Balance Computation Management Ledger' processes are considered for simultaneous / parallel execution.
- 'Balance Computation Management Ledger' process is offered in the user interface with Data Source as a runtime parameter. This is a legacy parameter retained solely for continuity purposes, will be removed from subsequent releases and will NOT be honoured by the process. As in, even if users choose a specific Data Source as a runtime parameter for said process via the user interface, the process will be executed for all data sources.
- All Accounting balance figures processed by this pipeline are as of a given MIS Date and Effective Date. This pipeline should be executed chronologically for contiguous dates through the fiscal year.
- By default, the Translation Required is enabled. You can enable or disable based on your requirements. This will exclude/include a translation task from the Balance Computation process.

Ensure that you complete the following procedures and then proceed with the use and execution of the Balance Computation Management Ledger Process:

- [Resave Hierarchies](#)

To use and execute the Balance Computation Management Ledger Process in the Process Orchestration, do the following:

1. To access the Balance Computation Management Ledger Process Pipeline, on the Home page, select the Process Orchestration. The Process Modeller page is displayed.
2. On the Process Modeller page, search and select the Balance Computation Management Ledger Process. The Process Flow page is displayed. This Process Flow is designed on the Drawing Canvas using the Transition, Activity, and Widgets Components available in the floating toolbar. A Data Service Widget is added at the beginning meant for sourcing the Data for Accounting Entries. Then the Balance Computation Widget is used for each GL Type Activity such as Assets, Liabilities, Expenses, Revenue, Gains, Losses, Contra Asset, Contra Liability, and Owner's Equity. The Activities are sequenced in the order of the Backdated Process, Daily Balances Process, and Average Balances Process. The Activities are repeated in the Run for each General Ledger Type and are executed in parallel. The Balance Translation Node is added in the end.
3. To view the details of any Activity, double-click on the Activity and the details related to its Activity, Transition, and Notification are displayed. On the drawing canvas, you can select and see the Definition, Data Fields, and Application Rule details.
4. To execute the Run, you can select the Run Parameter Values using the Execution button on the Process Flow page or on the Process Modeller page.

5. Go to the Process Modeller page to execute the Run. Click the Menu button corresponding to the Balance Computation Management Ledger Run Process that needs to be executed. Click Execute Run. The **Execution** page is displayed.
6. On the **Execution** page, to execute the Run with parameters, select With Parameters in the Execution Type List. Select or enter the required values for each field as follows.

**Note**

Only one Legal Entity and Source Code must be selected for execution of the Balance Computation process pipeline.

**Table 18-1 Balance Computation Management Ledger process - Execution page Field Names and Description**

Field Name	Description or Instruction
Extraction Date	Use the Calendar button to select the Extraction Date or Run Date for the Pipeline. Designation of this parameter as 'extraction date' is for legacy reasons and will be revised in subsequent releases. This parameter is to be treated as As-of Date.
Rate Date	Use the Calendar button to select the currency date.
Ledger Name	Select the required Ledgers from the Available List for processing or select All to process all the ledgers.
Revaluation Rule Name	Enter the revaluation rule name as same present in the ERP system.
Data Source	Use the Link button to select the required data source from the Available Values List, move it to the Selected Values List, and click OK.

**Note**

You must enter one rule at a time for each execution.

**Note**

You must pass Data source parameter as 0 to compute balances for overlapping Management Ledger segment values across multiple data sources including adjustments.

**Table 18-1 (Cont.) Balance Computation Management Ledger process - Execution page Field Names and Description**

Field Name	Description or Instruction
Legal Entity	<p>Use the Link button to select atleast one Legal Entity from the Available Values List, move it to the Selected Values List, and click OK.</p> <p><b>Note:</b> Do not select "All" option.</p> <p><b>Note:</b> Do not select multiple legal entities.</p> <p><b>Note:</b> Balance Computation Management Ledger process does not support Legal Entity or Data Source as filters. Select a valid Legal Entity for executing and processing data for all Legal Entities.</p>
Run Execution Description	Enter a description for the Run Pipeline.

**Note**

When the Ledger Name is selected as ALL and if you execute the process using CURL command, the Ledger field must be entered as -99.

7. To save the details and execute the Run, click the Apply button. The Run Execution begins.

**Note**

The execution of the Run Pipeline is triggered using the selected Extraction Date. See the [Managing Processes](#) Section for more details about the Processes.

8. To verify the Run Execution of the Balance Computation Management Ledger Process, do the following:
  - a. To open the Process Monitor page, on the Process Modeller page, click the Process Monitor button or select Process Flow Monitor on the Process Modeller menu.
  - b. The Process Monitor page is displayed listing all the Run Instances corresponding to the Balance Computation Management Ledger Process. On the Process Monitor page, search by the Process ID, or by the Process Name **Balance Computation Management Ledger**, and select the Process Instance for the required Run Pipeline (Process) that was executed.

The **Process Flow** page is displayed with the Run Execution Status on each Node of the Balance Computation Management Ledger Process.

9. To verify the Run Execution Logs, do the following:
  - a. On the **Process Monitor** page, click the required Process Instance for which you need to verify the Execution Logs. The **Process Flow** page is displayed with the Run Execution Status on each Node.
  - b. To see the Execution Status details of a Node, double-click on that Node. The Execution Status Details page is displayed. Click **Execution Logs**. The Log Viewer page is displayed, which lists all the Logs related to the Process Instance. To see the details of a log entry, click the **Show More** button. Click outside the Log Viewer page to close it.

## 18.5 PMF Dashboard for Balance Computation

You can monitor the process status of a pipeline using the PMF Dashboard. The Balance Computation Engine provides information on the following pipelines:

- Balance Computation
- Balance Revaluation
- Beginning of the Day

For more information on the activities, tasks within a pipeline and exporting the results, see [Filtering the PMF Dashboard](#) and [Exporting the PMF Process Activities](#).

### 18.5.1 PMF Dashboard Error Codes and Descriptions for Balance Computation Engine

This section provides information on the list of error codes that are related to Balance Computation, Beginning of Day and Balance Reconciliation pipelines on the PMF dashboard.

**Table 18-2 Balance Computation Management Ledger Error Codes**

Event Name	Event Message	Event Error Code	Event Error Descriptions
Legal Entity Parameter Validation	Failed	BCE1003	Invalid Legal Entity
Ledger Parameter Validation	Failed	BCE1004	Invalid Ledger
Extraction Date Parameter Validation	Failed	BCE1013	Invalid Extraction Date
Creating Intermediate Processing Entities	Failed	BCE1006	Invalid Response from Service
Creating Intermediate Processing Entities	Failed	BCE1010	Invalid table name
Creating Intermediate Processing Entities	Failed	BCE1002	Exception occurred
Creating Intermediate Processing Entities	Failed	BCE1007	Connection is not available
Records Processed	Completed	BCE1011	No Record Processed
Generate Processing Metadata	Failed	BCE1007	Connection is not available
Generate Processing Metadata	Failed	BCE1002	Exception occurred
Generate Processing Metadata	Failed	BCE1009	Table or view does not exist
Generate Processing Metadata	Failed	BCE1001	SQL Exception occurred
Loading Data Into Target Entities	Failed	BCE1007	Connection is not available
Loading Data Into Target Entities	Failed	BCE1009	Table or view does not exist
Loading Data Into Target Entities	Failed	BCE1008	Unique Constraint Violated

**Table 18-2 (Cont.) Balance Computation Management Ledger Error Codes**

Event Name	Event Message	Event Error Code	Event Error Descriptions
Loading Data Into Target Entities	Failed	BCE1001	SQL Exception occurred
Loading Data Into Target Entities	Failed	BCE1002	Exception occurred

**Table 18-3 Beginning of Day Management Ledger Error Codes**

Event Name	Event Message	Event Error Code	Event Error Descriptions
Loading Data Into Target Entity	Failed	BCE1001	SQL Exception occurred
Loading Data Into Target Entity	Failed	BCE1002	Exception occurred
Legal Entity Parameter Validation	Failed	BCE1003	Invalid Legal Entity
Ledger Parameter Validation	Failed	BCE1004	Invalid Ledger
Loading Data Into Target Entity	Failed	BCE1007	Connection is not available
Loading Data Into Target Entity	Failed	BCE1008	Unique Constraint Violated
Loading Data Into Target Entity	Failed	BCE1009	Table or view does not exist
Loading Data Into Target Entity	Failed	BCE1010	Invalid table name
Records Processed	Completed	BCE1011	No Record Processed
Creating Intermediate Processing Entities	Failed	BCE1012	Invalid Response from Service
Extraction Date Parameter Validation	Failed	BCE1013	Invalid Extraction Date

**Table 18-4 Balance Revaluation Error Codes**

Event Name	Event Message	Event Error Code	Event Error Descriptions
Revaluation Offset Calculation	Failed	BCE1001	SQL Exception occurred
Revaluation Offset Calculation	Failed	BCE1002	Exception occurred
Legal Entity Parameter Validation	Failed	BCE1003	Invalid Legal Entity
Ledger Parameter Validation	Failed	BCE1004	Invalid Ledger
Fiscal Period Validation	Failed	BCE1005	Fiscal period is disabled for a given date

**Table 18-4 (Cont.) Balance Revaluation Error Codes**

Event Name	Event Message	Event Error Code	Event Error Descriptions
Revaluation Offset Calculation	Failed	BCE1006	Invalid Response from Exchange Rates Service
Revaluation Offset Calculation	Failed	BCE1007	Connection is not available
Revaluation Offset Calculation	Failed	BCE1008	Unique Constraint Violated
Revaluation Offset Calculation	Failed	BCE1009	Table or view does not exist
Revaluation Offset Calculation	Failed	BCE1010	Invalid table name
Revaluation Offset Calculation	Completed	BCE1011	No Record Processed
Extraction Date Parameter Validation	Failed	BCE1013	Invalid Extraction Date
Revaluation Entries for Functional Currency Movement	Failed	BCE1001	SQL Exception occurred
Revaluation Entries for Functional Currency Movement	Failed	BCE1002	Exception occurred
Revaluation Entries for Functional Currency Movement	Failed	BCE1008	Unique Constraint Violated
Revaluation Entries for Functional Currency Movement	Failed	BCE1009	Table or view does not exist
Revaluation Entries for Functional Currency Movement	Failed	BCE1010	Invalid table name
Revaluation Entries for Functional Currency Movement	Completed	BCE1011	No Record Processed
Revaluation Entries for Functional Currency Movement Reversal	Failed	BCE1001	SQL Exception occurred
Revaluation Entries for Functional Currency Movement Reversal	Failed	BCE1002	Exception occurred
Revaluation Entries for Functional Currency Movement Reversal	Failed	BCE1008	Unique Constraint Violated
Revaluation Entries for Functional Currency Movement Reversal	Failed	BCE1009	Table or view does not exist
Revaluation Entries for Functional Currency Movement Reversal	Failed	BCE1010	Invalid table name
Revaluation Entries for Functional Currency Movement Reversal	Completed	BCE1011	No Record Processed

**Table 18-4 (Cont.) Balance Revaluation Error Codes**

Event Name	Event Message	Event Error Code	Event Error Descriptions
Revaluation Entries for Unrealized Gain or Loss Movement	Failed	BCE1001	SQL Exception occurred
Revaluation Entries for Unrealized Gain or Loss Movement	Failed	BCE1002	Exception occurred
Revaluation Entries for Unrealized Gain or Loss Movement	Failed	BCE1008	Unique Constraint Violated
Revaluation Entries for Unrealized Gain or Loss Movement	Failed	BCE1009	Table or view does not exist
Revaluation Entries for Unrealized Gain or Loss Movement	Failed	BCE1010	Invalid table name
Revaluation Entries for Unrealized Gain or Loss Movement	Completed	BCE1011	No Record Processed
Revaluation Entries for Unrealized Gain or Loss Movement Reversal	Failed	BCE1001	SQL Exception occurred
Revaluation Entries for Unrealized Gain or Loss Movement Reversal	Failed	BCE1002	Exception occurred
Revaluation Entries for Unrealized Gain or Loss Movement Reversal	Failed	BCE1008	Unique Constraint Violated
Revaluation Entries for Unrealized Gain or Loss Movement Reversal	Failed	BCE1009	Table or view does not exist
Revaluation Entries for Unrealized Gain or Loss Movement Reversal	Failed	BCE1010	Invalid table name
Revaluation Entries for Unrealized Gain or Loss Movement Reversal	Completed	BCE1011	No Record Processed
Revaluation Offset Calculation	Failed	BCE1016	The given Revaluation Rule is not configured in AFCS Rule Metadata
Exchange rates API Failure	Failed	BCE1017	Exchange rates request missing required data
Exchange rates API Failure	Failed	BCE1018	Exchange rates invalid date
Exchange rates API Failure	Failed	BCE1019	Exchange rates internal server error

## 18.6 Hierarchy Data Refresh for Balance Computation Engine

Hierarchies are used in the User Interface and they allow you to select one or more member nodes or leaf nodes. A Hierarchy browser is a widget that needs data from a cache maintained in internal processing of the entities. A dimension data may change over a period of time, therefore the hierarchy cache must be refreshed to align with the latest dimension data. For this purpose, there is a PMF process available in the AFCS by the name 'Hierarchy Resave'. This process can be executed to refresh the data of hierarchy. Once this step is done, then the Hierarchy Browser widgets start displaying the latest dimension members. The successful execution of PMF process indicates that the dimension data is refreshed in the internal cache. The Hierarchy Resave operation can be done multiple times for a date. It allows you to select more than one dimension hierarchies at once. You must re-save the Hierarchies and then proceed with the Run Pipeline execution.

- Management Ledger Computation Process of Balance Computation uses hierarchies as mentioned in the page below. The hierarchies will be displayed for user selection at a single level.
- PMF parameters are fixed, therefore it is not mandatory to provide hierarchy data in hierarchy tables and the seeded definitions use the underlying dimension entity itself. The Hierarchy data must be refreshed whenever there is a change to master data.
- All the three hierarchies are seeded, therefore the SCD must be used to load data into the respective dimension tables. Resaving of PMF process is required only when there is a dimension data change such as Legal entity, Data source & Currency.

Following are the seeded hierarchies and its corresponding mapping tables:

**Table 18-5 Seeded Hierarchies and their corresponding Mapping Tables**

Hierarchy Codes	Hierarchy Dimensions
BCE001	Currency Dimension - Currency for Balance Computation
BCE002	Data Source Dimension - Data Source for Balance Computation
BCE003	Legal Entity Dimension - Legal Entity for Balance Computation

### Note

It is recommended to use the following allowed characters in the Hierarchy browser during the PMF execution.

**Table 18-6 Allowed Special characters in Member/Code Identifier**

Field Name	Description or Instruction
@	At sign
#	Pound sign/Hash
~	Tilde
%	Percent
&	Ampersand
*	Asterisk

**Table 18-6 (Cont.) Allowed Special characters in Member/Code Identifier**

Field Name	Description or Instruction
(	Open parenthesis
)	Close parenthesis
+	Plus sign
	Pipe character
{	Open brace
}	Close brace
[	Open square bracket
]	Close square bracket
:	Colon
.	Period
;	Semicolon
<	Less than sign
>	Greater than sign
_	Underscore
-	Hyphen
!	Exclamation point
/	Forward slash
=	Equal sign
?	Question mark

**Table 18-7 Allowed Special characters in Member Description**

Field Name	Description or Instruction
#	Pound sign/Hash
~	Tilde
@	At sign
%	Percent
'	Apostrophe or Single quote
&	Ampersand
*	Asterisk
(	Open parenthesis
)	Close parenthesis
+	Plus sign
[	Open square bracket
]	Close square bracket
	Pipe character
{	Open brace
}	Close brace
:	Colon
.	Period
;	Semicolon
?	Question mark
!	Exclamation point
/	Forward slash

**Table 18-7 (Cont.) Allowed Special characters in Member Description**

Field Name	Description or Instruction
,	Comma
<	Less than sign
>	Greater than sign
_	Underscore
-	Hyphen
=	Equal sign

To re-save the BCE Hierarchies in the Process Orchestration, do the following:

1. On the Home Page, select **Process Orchestration** from the LHS menu. The **Process Modeller** page is displayed.
2. Create a pipeline **BCE Hierarchy Resave** and enter information in the **Process Details** window such as **Process Name**, **Process Description**, **App Package ID** as **Balance Computation Engine**, **Type** as **Run Pipeline**, **Spark DB** as **No** and the **Service ID Workspace** as **Oracle Financial Services Data Service for Analytics WS001** and click the **OK** Button to save the details in the **Process Orchestration** page before re-saving them.
3. On the Process Modeller Page, search for the created pipeline. The Process Flow Page is displayed. This Process Flow is designed on the Drawing Canvas using the Transition, Activity, and Widgets Components available in the floating toolbar. A **HIERARCHYRESAVE** Widget is added to the **START** for the purpose of resaving the Hierarchy.
4. Once the **HIERARCHYRESAVE** Widget is added in the Drawing Canvas, double-click the **HIERARCHYRESAVE** Node, the **HIERARCHYRESAVE** window is displayed. Enter information in the **Activity Desc** field. Under **Dynamic Parameters for HIERARCHYRESAVE** fields, select the Entities, and then the corresponding Hierarchy names, and select Load Type as Resave. Click Tick mark icon to save the details.
5. To execute the Run, you can select the Run Parameter Values using the Execution Button on the Process Flow Page or on the Process Modeller Page.
6. Go to the Process Modeller Page to execute the Run. Click the Menu Button corresponding to the pipeline. Click Execute Run. The **Execution** Page is displayed.
7. On the **Execution** Page, select the Execution Type as Without Parameters. Enter a unique value for the Object ID.
8. To save the details and execute the Run, click the Apply Button. The resaving process begins.

**Note**

See the [Managing Processes](#) section for more details about the Processes.

9. To verify the Run Execution (BCE Hierarchy Resave), do the following:
  - a. To open the Process Monitor Page, on the Process Modeller Page, click the Process Monitor Button or select Process Flow Monitor on the Process Modeller Menu.
  - b. The Process Monitor Page is displayed listing all the Run Instances corresponding to the BCE Hierarchy Resave Processes. On the Process Monitor Page, search by the

Process ID, or by the Process Name BCE Hierarchy Resave, and select the Process Instance for the required Run Pipeline (BCE Hierarchy Resave) that was executed.

The **Process Flow** Page is displayed with the Run Execution Status on each Node of the BCE Hierarchy Resave Process.

10. To verify the Run Execution Logs, do the following:
  - a. On the **Process Monitor** Page, click the required Process Instance for which you need to verify the Execution Logs. The **Process Flow** Page is displayed with the Run Execution Status on each Node.
  - b. To see the Execution Status details of a Node, double-click on that Node. The Execution Status details Page is displayed. Click **Execution Logs**. The Log Viewer Page is displayed, which lists all the Logs related to the Process Instance. To see the details of a log entry, click the **Show More** Button. Click outside the Log Viewer Page to close it.

## 18.7 Balance Computation Management Ledger Initialization

The Balance Computation Management Ledger Initialization run pipeline (Process) uses the fiscal period data configured for legal entities, that will be used for execution of other run pipelines in BCE.

### Note

- The Balance Computation Management Ledger Initialization process must be executed Daily before the execution of other pipelines such as Beginning of Day Management Ledger, Balance Computation Management Ledger and Balance Revaluation Management Ledger.
- Fiscal period must be configured for all the Legal Entities that will be processed as part of the Balance Computation runs. Hence, the Initialization process can be executed only after this configuration and other pipelines must be executed after the execution of Initialization pipeline.
- If there are any changes in the fiscal period after executing the Balance Computation Engine Management Ledger Initialization process for a given date, you must re-execute this initialization process and then execute other BCE pipelines.

### 18.7.1 Use and Execute Balance Computation Management Ledger Initialization Pipeline

The Balance Computation Management Ledger Initialization run pipeline (Process) uses the fiscal period data configured for legal entities, that will be used for execution of other run pipelines in BCE.

To create and execute the Balance Computation Management Ledger Initialization process in the Process Orchestration, do the following:

1. To access the Balance Computation Management Ledger Initialization Pipeline, on the Home Page, select the Process Orchestration.

The Process Modeller Page is displayed.

2. On the Process Modeller Page, search and select the Balance Computation Management Ledger Initialization Pipeline.  
The Process Flow Page is displayed.
3. To execute the Run, you can select the Run Parameter values using the Execution icon on the Process page or on the Process Modeller page.
4. Navigate to the Process Modeller page to execute the Run and Click **Execution** icon.  
The **Execution** Page is displayed.
5. On the Execution page, to execute the Run with parameters, select With Parameters in the Execution Type List. Select or enter the required values for each field as follows:

**Table 18-8 Balance Computation Management Ledger Initialization Pipeline process - Execution page Field Names and Description**

Field Name	Description or Instruction
Extraction Date	Use the Calendar button to select the Extraction Date for the pipeline.

6. To save the details and execute the Run, click **Execute**. The Run Execution begins.

**Note**

The execution of the Run Pipeline is triggered using the selected Extraction Date.

7. To verify the Run Execution of the Balance Computation Management Ledger Initialization Pipeline process, do the following:
  - a. To open the **Process Monitor** Page, on the **Process Modeller** Page, click the **Process Monitor** Button or select **Process Flow Monitor** on the **Process** Menu on the **Process Modeller** Page.
  - b. The **Process Monitor** Page is displayed listing all the Run Instances corresponding to the Balance Computation Management Ledger Initialization Pipeline process. On the **Process Monitor** Page, search by the Process ID, or by the Process Name Balance Computation Management Ledger Initialization Pipeline, and select the Process Instance for the required Run Pipeline (Process) that was executed.
8. The **Process Flow** Page is displayed with the Run Execution Status on each Node of the Balance Computation Management Ledger Initialization Pipeline process.
9. To verify the Run Execution Logs, do the following:
  - a. On the **Process Monitor** Page, click the required Process Instance for which you need to verify the Execution Logs.
  - b. To see the Execution Status details of a Node, double-click on that Node. The Execution Status details Page is displayed. Click **Execution Logs**.

The Log Viewer Page is displayed, which lists all the Logs related to the Process Instance. To see an elaborated information of a log entry, click the **Show More** button. Click outside the Log Viewer page to close it.

## 18.8 Revaluation

The Balance Revaluation Process is used to adjust the Account Balance Figures of the Denominated Currencies other than the Accounting Currency. The Balance Revaluation

Adjustments represent the difference in the Balance Value due to changes in the Currency Conversion Rates between the Date of the Original Journal Entry and the Revaluation Date.

AFCS Revaluation process facilitates reflection of changes to balance figures designated in functional currency terms because of variation in exchange rates between entered and functional currencies over time, also recording Unrealised Gain or Loss movements corresponding to such changes.

AFCS will automate obtaining revaluation configuration information from the Oracle ERP Cloud instance it is configured to be linked with, and use that as the basis for its revaluation process. This covers the list of code combinations that need to be revalued (scope of revaluation), unrealized gain/loss accounts to which such amounts are posted, and reversal time line, where relevant. This enables Revaluation process to be aligned with ERP system.

The Revaluation process sequentially generates four revaluation journals and loads them into the Revaluation Entries entity. The daily tasks of the Revaluation fetches the revaluation non-reversal journal entries from the revaluation entries table.

#### **Note**

The revaluation reversal journal will generate the journal entries only based on the reversal date of the ERP metadata entity.

#### **Note**

Please note that AFCS will not skip balance records in basis ledger that have entered currency the same as functional currency of revalued ledger when revaluation process in Financials Cloud is set up for all currencies.

#### **Note**

When revaluation is performed on a ledger with another as the basis, AFCS will consistently follow the instructed basis irrespective of relative values of Entered and Functional currency codes within basis and revalued ledgers or across the two.

#### **Note**

In case of fresh provisioning and for tenants upgraded to AFCS 26A, it is mandatory to load Functional currency code into the Dimension Ledger prior to Revaluation executions.

#### **Note**

AFCS does not offer functionality to automatically net unrealised gain and loss amounts, or post such net amount against a single combination of CoA and ML segment values, if unrealised gain and unrealised loss segment values defined in ERP for a given rule are distinct.

**Note**

Should

- the segment code combinations that unrealised gain/loss values from revaluation are posted against in ERP GL are also in use for maintenance of other balance information unrelated to such unrealised gain/loss, and
- such code combinations be within scope of subsequent revaluation as advised by user-configured revaluation rules in ERP GL, AFCS will NOT take the unrealised gain/loss portion up for revaluation.

## 18.8.1 Revaluation Basis

Revaluation execution is now based on a new feature called Revaluation Basis, where the value of the revaluation basis ledger is the key value for revaluation process execution. If the Revaluation Basis has the value as 'SELF,' then the ledger name that is provided as a runtime parameter during the process execution is considered for the revaluation execution of journals. If the Revaluation Basis has the value as 'PRIMARY,' then the primary ledger identifier retrieves the balances from the Management Ledger period balance table, and then an entry is generated for the reporting ledger to proceed with revaluation execution.

Key Points to Consider:

- When revaluation is performed on a ledger with another as the basis, AFCS will consistently follow the instructed basis in such metadata irrespective of relative values of Entered and Functional currency codes within basis and revalued ledgers or across the two.
- In case of fresh provisioning and for tenants upgraded to AFCS 26A, it is mandatory to load Functional currency code into the Dimension Ledger prior to Revaluation executions.
- AFCS will not skip any balance data based on Entered Currency value when revaluation rule metadata advises user configuration of 'ALL' currencies for a given rule.
- Multiple revaluation rules for a given ledger should NOT be concurrently executed. Attempts to do so may result in incomplete or incorrect outcomes that may not be reversible.
- When performing revaluation of a ledger Lr with another Lb as the basis, the scope of revaluation will be determined solely referring the basis ledger Lb. In this context, should revaluation be requested only for Revised Balance through user choice of runtime parameters, the service will refer basis ledger Lb for revision of balance with respect to immediate prior execution, and not the ledger Lr being revalued. This should be noted when requesting revaluation only for Revised Balance while requesting revaluation of a ledger Lr with another Lb as the basis.

## 18.8.2 Creating Revaluation Rule ESS Job for AFCS

This section provides information on creating an Revaluation Rule ESS job in the AHCS ERP instance.

1. After logging into ERP AHCS instance, on the Home page, navigate to **Setup and Maintenance** and click **Task** icon and click **Search**.

The Search page is displayed.

2. Search for **Define Enterprise Scheduler Job Definitions and Job Sets for Financials** and under **Task List** select **Manage Enterprise Scheduler Job Definitions Job Sets for Financial Supply Chain Management, and Related Applications**.
3. Under **Manage Job Definitions** tab, click **Add** icon.  
The Create Job Definition page is displayed.
4. Enter information in the following fields.

**Table 18-9 Create Job Definition - Field Names and Description**

Field Name	Description or Instruction
Display Name	Enter the display name as 'Revaluation Rule and Accounts Export for AFCS'.
Name	Enter the name as 'GIRevalExportAFCS'.
Path	Enter the path as 'afcs'.
Application	Select the application as 'General Ledger' from the dropdown list.
Description	Provide the description for job created.
Job Application Name	Select the job application name as 'FscmEss' from the dropdown list.
Job Type	Select the job type as 'PlsqlJobType' from the dropdown list.
Procedure Name	Enter the procedure name as 'GL_REVAL_FILTER_UTILITY.GET_ACCOUNTS'.
Default Output Format	Select the output format as 'TXT' from the dropdown list.
Allow Multiple Pending Submissions	Select 'True' from the dropdown list.

5. Select the **User Properties** tab and click **Add** icon.
6. Enter information in the following fields.  
Enter information in the User Property fields
  - Name - Enter the name as 'numberofArgs' for the user property that is created.
  - Data Type- Select the 'String' data type from the dropdown list.
  - Default Value- Enter the default value as '3'.
7. Click **Add** icon to create parameters for the associated job.  
Enter information in the **Create Parameter** fields
  - **Parameters Prompt**- Enter the parameter prompt as 'Accounting Date'.
  - **Data Type**- Select the 'Date or Time' data type from the dropdown list.
  - **Page Element**- Displays Date picker as default value.
  - **Show**- Select 'Date only' option.
  - **Default Date Format**- Select the date format as 'yyyy/MM/dd' from the dropdown list.
  - **Default Value**- Select the 'System Date' from the dropdown list.
  - **Tooltip**- Select 'Required' checkbox.
8. Click **Save and Create Another** button.  
Enter information in the **Create Parameter** fields for Revaluation.

- **Parameters Prompt**- Enter the parameter prompt as 'Revaluation Name'.
  - **Data Type**- Select as 'String' data type from the dropdown list.
  - **Page Element**-Select as 'Text box' from the dropdown list.
  - **Tooltip**- Select 'Required' checkbox.
9. Click **Save and Create Another** button.  
Enter information in the **Create Parameter** fields for Ledger.
    - **Parameters Prompt**- Enter the parameter prompt as 'Ledger Name'.
    - **Data Type**- Select as 'String' data type from the dropdown list.
    - **Page Element**-Select as 'Text box' from the dropdown list.
    - **Tooltip**- Select 'Required' checkbox.
  10. Click **Save and Close** button for parameter creation.
  11. Click **Save and Close** in the Create Job Definition page.  
A confirmation message on saving the created job is displayed.
  12. Click **Done** in the Manage Job Definitions page.
  13. Sign out from the ERP AHCS Instance.
  14. Sign In as a Security Manager into Oracle Applications Cloud user interface.  
To assign roles to execute this job, see [How to Grant Execution Privileges to ESS custom Jobs \(Doc ID 2251561.1\)](#).
  15. Sign out from the application and click **Confirm**.
  16. Sign In as a Financials user and navigate to Scheduled Processes.
  17. Search for the revaluation job that you created and the process details page is displayed.
  18. Enter the Ledger Name, Revaluation Name and the Accounting Date and click **Submit**.  
A confirmation message is displayed.
  19. Click **OK**. Refresh the Search results page.  
The Revaluation Rule and Export for AFCS ESS job is scheduled successfully.
  20. Under Process details of the ESS job, click the **Attachment** and you can download the scheduled process job details.

### 18.8.3 Revaluation-ML Segments Default Value for Unrealised Gain and Loss Figures

This feature enables users to define default Management Ledger (ML) segment values against which the unrealised gain/loss movements and balances should be captured during revaluation. Using this feature, users can review the eligible ML segments for each ledger and specify whether each segment value should be derived **As per ML** or assigned using a predefined **Dimension Member** value.

If a ledger does not have its own ML segment mapping, the system uses the "Default" ledger mapping to determine the applicable ML segments for that ledger. The saved user selections are then applied on top of the ledger or default mapping.

This configuration must be completed before the Revaluation Preparation pipeline execution and must not be altered when other revaluation processes are in execution.

### 18.8.3.1 Configuring Management Ledger Segments to Default Value

This feature allows users to specify, for each ledger and eligible ML segment, whether the segment value should be derived from the Management Ledger or assigned using a predefined dimension member value. For ledgers that do not have specific ML segment mappings, the system uses the "Default" ledger mapping and applies any saved user-defined defaults.

To configure ML segment default values for ledgers, follow these steps:

1. Login to the AFCS application.
2. On the Home page, navigate to **Administration** and select **Revaluation- ML Segment Value Assignment** tab. The list of Ledgers to which the ML segments or Dimension members are mapped is displayed.
3. Click **Open** against the corresponding ledger to configure the dimension value.  
By default, the segment value is assigned to "As per ML" option in the User interface.
4. Select the **Dimension Member** option from the drop down list and assign the corresponding **Dimension Member Code**.

Following are the validations for selecting Dimension member codes:

- If Dimension member code is not entered, "Code is required." message is displayed.
  - If Dimension member code entered is too long, then the "Value is too long. Maximum length is <--->" message is displayed.
  - If Dimension member code entered is invalid, the "Code not found." message is displayed.
  - If Dimension member code entered is valid, the "Code validated." message is displayed.
5. Click **Save** to save the mapped segment value. The updated Revaluation- ML segment value assignment is displayed in the summary page.

#### Note

On the Revaluation-ML Segment Value Assignment page, click **Columns** icon to enable or disable any column that users wish to hide or list in the summary page.

### 18.8.4 Use and Execute Revaluation Preparation Pipeline

Ensure that ERP settings and Segment Mapping resave is performed before executing this pipeline. This pipeline is enabled to fetch Revaluation rules and accounts from ERP and load into AFCS for downstream consumption.

To create and execute the Revaluation process (Revaluation Pipeline Preparation) in the Process Orchestration, do the following:

1. To access the Revaluation Preparation Pipeline, on the Home Page, select the Process Orchestration.

The Process Modeller Page is displayed.

2. On the Process Modeller Page, search and select the Revaluation Preparation Pipeline process.

The Process Flow Page is displayed. The Activities are repeated in the Run for each General Ledger Type and are executed in parallel.

3. To view the details of any Activity, double-click on the Activity and the details related to its Activity, Transition, and Notification are displayed. GL Type for the Generate Offsets Task need to be NULL or blank. On the drawing canvas, you can select and see the Definition, Data Fields, and Application Rule details.
4. To execute the Run, you can select the Run Parameter values using the Execution icon on the Process page or on the Process Modeller page.
5. Navigate to the Process Modeller page to execute the Run and Click **Execution** icon. The **Execution** Page is displayed.
6. On the Execution page, to execute the Run with parameters, select With Parameters in the Execution Type List. Select or enter the required values for each field as follows:

**Table 18-10 Revaluation Pipeline Preparation process - Execution page Field Names and Description**

Field Name	Description or Instruction
As of Date	Use the Calendar button to select the As of Date for the pipeline.
Ledger Name	Select the Ledger pertaining to the ERP_CC_ID (Code Combination ID) that has undergone revaluation in the ERP system.
Revaluation Rule Name	Enter the revaluation rule name as same present in the ERP system.

7. To save the details and execute the Run, click **Execute**. The Run Execution begins.

**Note**

The execution of the Run Pipeline is triggered using the selected As of Date.

8. To verify the Run Execution of the Revaluation Pipeline Preparation process, do the following:
  - a. To open the **Process Monitor** Page, on the **Process Modeller** Page, click the **Process Monitor** Button or select **Process Flow Monitor** on the **Process** Menu on the **Process Modeller** Page.
  - b. The **Process Monitor** Page is displayed listing all the Run Instances corresponding to the Revaluation Pipeline Preparation process. On the **Process Monitor** Page, search by the Process ID, or by the Process Name Revaluation Pipeline Preparation, and select the Process Instance for the required Run Pipeline (Process) that was executed.
9. The **Process Flow** Page is displayed with the Run Execution Status on each Node of the Revaluation Pipeline Preparation process.
10. To verify the Run Execution Logs, do the following:
  - a. On the **Process Monitor** Page, click the required Process Instance for which you need to verify the Execution Logs.
  - b. To see the Execution Status details of a Node, double-click on that Node. The Execution Status details Page is displayed. Click **Execution Logs**.

The Log Viewer Page is displayed, which lists all the Logs related to the Process Instance. To see an elaborated information of a log entry, click the **Show More** button. Click outside the Log Viewer page to close it.

## 18.8.5 Use and Execute Persist Segment Combinations Pipeline

Ensure that ERP settings and Segment Mapping resave is performed before executing this pipeline. This pipeline is used to move the generates unique ML COA segments combinations post decomposition and revaluation preparation.

### ① Note

This is a mandatory prerequisite before any result area movement or reconciliation runs.

To create and execute the Persist Segment Combinations Pipeline in the Process Orchestration, do the following:

1. To access the Persist Segment Combinations Pipeline, on the Home Page, select the Process Orchestration.  
The Process Modeller Page is displayed.
2. On the Process Modeller Page, search and select the Persist Segment Combinations Pipeline process.  
The Process Flow Page is displayed.
3. To view the details of any Activity, double-click on the Activity and the details related to its Activity, Transition, and Notification are displayed. On the drawing canvas, you can select and see the Definition, Data Fields, and Application Rule details.
4. To execute the Run, you can select the Run Parameter values using the Execution icon on the Process page or on the Process Modeller page.
5. Navigate to the Process Modeller page to execute the Run and Click **Execution** icon.  
The **Execution** Page is displayed.
6. On the Execution page, to execute the Run with parameters, select With Parameters in the Execution Type List. Use the Calendar button to select the As of Date for the pipeline.
7. To save the details and execute the Run, click **Execute**. The Run Execution begins.
8. To verify the Run Execution of the Persist Segment Combinations Pipeline process, do the following:
  - a. To open the **Process Monitor** Page, on the **Process Modeller** Page, click the **Process Monitor** Button or select **Process Flow Monitor** on the **Process** Menu on the **Process Modeller** Page.
  - b. The **Process Monitor** Page is displayed listing all the Run Instances corresponding to the Persist Segment Combinations Pipeline process. On the **Process Monitor** Page, search by the Process ID, or by the Process Name Persist Segment Combinations Pipeline, and select the Process Instance for the required Run Pipeline (Process) that was executed.
9. The **Process Flow** Page is displayed with the Run Execution Status on each Node of the Persist Segment Combinations Pipeline process.
10. To verify the Run Execution Logs, do the following:

- a. On the **Process Monitor** Page, click the required Process Instance for which you need to verify the Execution Logs.
- b. To see the Execution Status details of a Node, double-click on that Node. The Execution Status details Page is displayed. Click **Execution Logs**.

The Log Viewer Page is displayed, which lists all the Logs related to the Process Instance. To see an elaborated information of a log entry, click the **Show More** button. Click outside the Log Viewer page to close it.

## 18.8.6 Use and Execute the Revaluation Process

Revaluation Preparation process should be executed before any execution of Revaluation process in AFCS. While there may not be user-initiated changes made to revaluation rules configured in ERP between successive revaluation executions in AFCS, systemic establishment of variation to the metadata is mandatory.

Based on the Revaluation rule fetched from the ERP:

- Revaluation processing in BCE is carried out
- Offset accounts are assigned

### ① Note

More than one Balance Revaluation Management Ledger process should not be simultaneously executed with the same set of runtime parameters. Refer below table for the list of runtime parameters supported.

### ① Note

Ensure that the Period to which you are executing Balance Revaluation Management Ledger process is an Open Period (locked) as set in the [Legal Entity Settings](#) section.

### ① Note

When Revaluation Type parameter in Balance Revaluation Management Ledger Process is selected as "Revised Balances":

- Ensure that Revaluation Rules in ERP are not modified intraday.
- Ensure that the exchange rates used for revaluation are not modified intraday.
- Ensure that for a given Extraction Date-Ledger-Revaluation Rule Name combination, the remaining input parameters are not changed between multiple intraday executions.

If any of the above conditions are not or cannot be met, for accurate results of revaluation, please select Revaluation Type parameter as "All Balances" in Balance Revaluation Management Ledger Process.

### Key Points to Consider:

- Revaluation should only be performed for rules completely configured in the Financials Cloud service instance that AFCS is deployed with.

- Revaluation should be invoked with the Rule Name exactly as configured in the Financials Cloud service instance that AFCS is deployed with.
- Revaluation should be invoked with the following parameters: Ledger, Rule Name, Effective Date, As of Date, Rate Date, Rate Version and Revaluation Type.
- Not more than one revaluation rule for a given ledger should be executed at the same time - as in, if there are three rules for Ledger A, rule 1, rule 2 and rule 3 should be executed strictly in sequence. Not more than one rule per ledger should be executed at any point in time.
- Revaluation may optionally be invoked with a list of Rule Names relevant to a given ledger.
- When invoked with a set of Rule Names the rules will be executed in the sequence they are listed.
- Note that Financials Cloud does not stop revaluation rules for a ledger being configured with overlaps in ranges of code combinations to be revalued.
- Revaluation may also be executed specifically for balance information that has been revised since immediately prior execution. When attempting this, the following should be observed:
  - Given that this is that amount to re-execution, invocation to achieve this should be with identical run-time parameters.
  - The run-time parameter 'Revaluation Type' should be set to 'Revised Balance'.
  - All other guidelines for invocation of revaluation also apply when executed solely for balance information that has been revised since immediately prior execution".

Ensure that you Resave Hierarchies and then proceed with the use and execution of the Balance Computation Management Ledger Process.

To create and execute the Revaluation Process (Balance Revaluation Management Ledger Process) in the Process Orchestration, do the following:

1. To access the Balance Revaluation (Balance Revaluation Management Ledger Process) Pipeline, on the Home Page, select the Process Orchestration.  
The Process Modeller Page is displayed.
2. On the Process Modeller Page, search and select the Balance Revaluation Management Ledger process.  
The Process Flow Page is displayed. This Process Flow is designed on the Drawing Canvas using the Transition, Activity, and Widgets Components available in the floating tool bar. The Balance Computation Widget is used for each GL Type Activity such as Assets, Liabilities, Expenses, Revenue, Gains, Losses, Contra Asset, Contra Liability, and Owner's Equity set in the Balance Revaluation Settings Section. The Activities are repeated in the Run for each General Ledger Type and are executed in parallel.
3. To view the details of any Activity, double-click on the Activity and the details related to its Activity, Transition, and Notification are displayed. GL Type for the GenerateOffsets Task need to be NULL or blank. On the drawing canvas, you can select and see the Definition, Data Fields, and Application Rule details.
4. To execute the Run, you can select the Run Parameter Values using the Execution Button on the Process Page or on the Process Modeller Page.
5. Go to the Process Modeller Page to execute the Run. Click the Menu Button corresponding to the Balance Revaluation Management Ledger Run process that needs to be executed. Click **Execution** icon.

The **Execution** Page is displayed.

6. On the Execution Page, to execute the Run with parameters, select With Parameters in the Execution Type List. Select or enter the required values for each field as follows:

**Table 18-11 Balance Revaluation Management Ledger Process - Execution Page Field Names and Description**

Field Name	Description or Instruction
Rate Date	Use the Calendar button to select the currency date.
Extraction Date	Use the Calendar Button to select the Extraction Date or As of Date for the pipeline.
Revaluation Type	Select the appropriate option from the available list. <ul style="list-style-type: none"> <li>All Balances: This type processes all the available Balance computation runs for a specific date.</li> <li>Revised Balances: This type processes only the latest available Balance computation run for a specific date.</li> </ul>
Ledger Name	Select the Ledger pertaining to the ERP_CC_ID (Code Combination ID) that has undergone revaluation in the ERP system. <div data-bbox="964 905 1466 1037" style="border: 1px solid #ccc; border-radius: 10px; padding: 10px; margin-top: 10px;"> <p><b>Note</b></p> <p>Do not select "All" option.</p> </div> <div data-bbox="964 1077 1466 1209" style="border: 1px solid #ccc; border-radius: 10px; padding: 10px; margin-top: 10px;"> <p><b>Note</b></p> <p>Do not select multiple ledgers.</p> </div>
Legal Entity	Use the Link button to select atleast one Legal Entity from the Available Values List, move it to the Selected Values List, and click OK. <p><b>Note:</b> Do not select "All" option.</p> <p>Note: Do not select "All" option.</p> <p><b>Note:</b> Balance Revaluation Management Ledger process does not support Legal Entity or Data Source as filters. Select a valid Legal Entity for executing and processing data for all Legal Entities.</p> <p><b>Note:</b> The Fiscal Period locking check for the Legal Entity is enabled to verify the open or closed status prior to processing them.</p>

**Table 18-11 (Cont.) Balance Revaluation Management Ledger Process - Execution Page Field Names and Description**

Field Name	Description or Instruction
Revaluation Rule Name	Enter the revaluation rule name as same present in the ERP system.
Rate Version	Enter the required exchange rate version.

**Note**

You can enter multiple rules for execution using commas as separators. Do not use spaces or other delimiters to ensure rules are processed sequentially.

- To save the details and execute the Run, click **Execute**. The Run Execution begins.

**Note**

The execution of the Run Pipeline is triggered using the selected As of Date. See the [Managing Processes](#) Section for more details about the Processes.

- To verify the Run Execution of the Balance Revaluation Management Ledger Process, do the following:
  - To open the **Process Monitor** Page, on the **Process Modeller** Page, click the **Process Monitor** Button or select **Process Flow Monitor** on the **Process** Menu on the **Process Modeller** Page.
  - The **Process Monitor** Page is displayed listing all the Run Instances corresponding to the Balance Revaluation Management Ledger Process. On the **Process Monitor** Page, search by the Process ID, or by the Process Name Balance Revaluation Management Ledger, and select the Process Instance for the required Run Pipeline (Process) that was executed.
- The **Process Flow** Page is displayed with the Run Execution Status on each Node of the Balance Computation Management Ledger Process.
- To verify the Run Execution Logs, do the following:
  - On the **Process Monitor** Page, click the required Process Instance for which you need to verify the Execution Logs.
  - To see the Execution Status details of a Node, double-click on that Node. The Execution Status details Page is displayed. Click **Execution Logs**.

The Log Viewer Page is displayed, which lists all the Logs related to the Process Instance. To see an elaborated information of a log entry, click the **Show More** Button. Click outside the Log Viewer Page to close it.

## 18.8.7 Use and Execute the Balance Revaluation Retrospective Management Ledger Process

AFCS will support retrospective revaluation. A retrospective revaluation is one in which the accounting/effective date for which revaluation is performed is prior to the as-of date on which such execution is requested.

To enable this, AFCS revaluation process will accept the following runtime parameters: effective date, as of date, ledger, rule and rate date.

Please note that when revaluation is performed retrospectively, all process pipelines as necessary should also be executed such that the refreshed set of balance figures are reflected and accessible from Results.

Alongside this ability to perform revaluation retrospectively, AFCS will also support multiple executions of revaluation with a given set of runtime parameters. This is intended to ensure that exceptions that necessitate such repeat executions can be supported without any error in Management Ledger outcomes - balance and related movement information.

Considering that change to balance information itself, scope or actions required by rule configuration and rates to be applied collectively determine the set of data that should be processed upon any given execution of revaluation, it is recommended that such re-execution be limited to exceptional circumstances.

AFCS will also support revaluation of a ledger with another as basis, if so configured in Financials Cloud GL and instructed by revaluation metadata obtained by AFCS from said service.

### Note

More than one Balance Revaluation Retrospective Management Ledger process should not be simultaneously executed with the same set of runtime parameters. Refer below table for the list of runtime parameters supported.

### Note

Ensure that the Period to which you are executing Balance Revaluation Retrospective Management Ledger process is an Open Period (locked) as set in the [Legal Entity Settings](#) section.

**Note**

When Revaluation Type parameter in Balance Revaluation Retrospective Management Ledger Process is selected as "Revised Balances":

- Ensure that revaluation rules in ERP are not modified after the end of prior period until that prior period's adjustment period has concluded.
- Ensure that the exchange rates(as per Rate Date and Rate Version input parameters) used for prior period revaluation is not modified after the end of prior period until that prior period's adjustment period has concluded.
- Ensure that for a given Extraction Date- Effective Date-Ledger-Revaluation Rule Name combination, the remaining input parameters are not changed between multiple intraday executions.

If any of the above conditions are not or cannot be met, for accurate results of revaluation, please select Revaluation Type parameter as "All Balances" in Balance Revaluation Retrospective Management Ledger Process.

**Key Points to Consider:**

- When revaluation is performed on a ledger with another as the basis, AFCS will consistently follow the instructed basis in such metadata irrespective of relative values of Entered and Functional currency codes within basis and revalued ledgers or across the two.
- In case of fresh provisioning and for tenants upgraded to AFCS 26A, it is mandatory to load Functional currency code into the Dimension Ledger prior to Revaluation executions.
- AFCS will not skip any balance data based on Entered Currency value when revaluation rule metadata advises user configuration of 'ALL' currencies for a given rule.
- Multiple revaluation rules for a given ledger should NOT be concurrently executed. Attempts to do so may result in incomplete or incorrect outcomes that may not be reversible.
- Revaluation should only be performed for rules completely configured in the Financials Cloud service instance that AFCS is deployed with.
- Revaluation should be invoked with the Rule Name exactly as configured in the Financials Cloud service instance that AFCS is deployed with.
- Revaluation should be invoked with the following parameters: Ledger, Rule Name, Effective Date, As of Date, Rate Date, Rate Version and Revaluation Type.
- Not more than one revaluation rule for a given ledger should be executed at the same time - as in, if there are three rules for Ledger A, rule 1, rule 2 and rule 3 should be executed strictly in sequence. Not more than one rule per ledger should be executed at any point in time.
- Revaluation may optionally be invoked with a list of Rule Names relevant to a given ledger.
- When invoked with a set of Rule Names the rules will be executed in the sequence they are listed.
- Note that Financials Cloud does not stop revaluation rules for a ledger being configured with overlaps in ranges of code combinations to be revalued.
- Revaluation may also be executed specifically for balance information that has been revised since immediately prior execution. When attempting this, the following should be observed:

- Given that this is that amount to re-execution, invocation to achieve this should be with identical run-time parameters.
- The run-time parameter 'Revaluation Type' should be set to 'Revised Balance'.
- All other guidelines for invocation of revaluation also apply when executed solely for balance information that has been revised since immediately prior execution".

To create and execute the Balance Revaluation Retrospective Management Ledger in the Process Orchestration, do the following:

1. To access the Balance Revaluation Retrospective Management Ledger Pipeline, on the Home Page, select the Process Orchestration.

The Process Modeller Page is displayed.

2. On the Process Modeller Page, search and select the Balance Revaluation Retrospective Management Ledger process.

The Process Flow Page is displayed. This Process Flow is designed on the Drawing Canvas using the Transition, Activity, and Widgets Components available in the floating tool bar. The Balance Computation Widget is used for each GL Type Activity such as Assets, Liabilities, Expenses, Revenue, Gains, Losses, Contra Asset, Contra Liability, and Owner's Equity set in the Balance Revaluation Settings Section. The Activities are repeated in the Run for each General Ledger Type and are executed in parallel.

3. To view the details of any Activity, double-click on the Activity and the details related to its Activity, Transition, and Notification are displayed. GL Type for the Generate Offsets Task need to be NULL or blank. On the drawing canvas, you can select and see the Definition, Data Fields, and Application Rule details.
4. To execute the Run, you can select the Run Parameter Values using the Execution Button on the Process Page or on the Process Modeller Page.
5. Go to the Process Modeller Page to execute the Run. Click the **Menu** button corresponding to the Balance Retrospective Revaluation Management Ledger Run process that needs to be executed. Click **Execution** icon.

The **Execution** Page is displayed.

6. On the Execution Page, to execute the Run with parameters, select With Parameters in the Execution Type List. Select or enter the required values for each field as follows:

**Table 18-12 Balance Revaluation Retrospective Management Ledger process - Execution Page Field Names and Description**

Field Name	Description or Instruction
Rate Date	Use the Calendar button to select the currency date.
Extraction Date	Use the Calendar Button to select the Extraction Date or As of Date for the pipeline.
Effective Date	Use the Calendar Button to select the Effective Date for which the revaluation is performed for the pipeline.
Run Purpose	Select the run purpose details from the drop down.

**Table 18-12 (Cont.) Balance Revaluation Retrospective Management Ledger process - Execution Page Field Names and Description**

Field Name	Description or Instruction
Revaluation Type	<p>Select the appropriate option from the available list.</p> <ul style="list-style-type: none"> <li>All Balances: This type processes all the available Balance computation runs for a specific date.</li> <li>Revised Balances: This type processes only the latest available Balance computation run for a specific date.</li> </ul>
Ledger Name	<p>Select the Ledger pertaining to the ERP_CC_ID (Code Combination ID) that has undergone revaluation in the ERP system.</p> <div data-bbox="964 667 1466 802" style="border: 1px solid #ccc; border-radius: 10px; padding: 10px; margin-top: 10px;"> <p><b>Note</b></p> <p>Do not select "All" option.</p> </div> <div data-bbox="964 842 1466 976" style="border: 1px solid #ccc; border-radius: 10px; padding: 10px; margin-top: 10px;"> <p><b>Note</b></p> <p>Do not select multiple ledgers.</p> </div>
Legal Entity	<p>Use the Link button to select atleast one Legal Entity from the Available Values List, move it to the Selected Values List, and click OK.</p> <div data-bbox="964 1142 1466 1276" style="border: 1px solid #ccc; border-radius: 10px; padding: 10px; margin-top: 10px;"> <p><b>Note</b></p> <p>Do not select "All" option.</p> </div> <div data-bbox="964 1316 1466 1451" style="border: 1px solid #ccc; border-radius: 10px; padding: 10px; margin-top: 10px;"> <p><b>Note</b></p> <p>Do not select multiple legal entities.</p> </div> <p><b>Note:</b> The Fiscal Period locking check for the Legal Entity is enabled to verify the open or closed status prior to processing them.</p>

**Table 18-12 (Cont.) Balance Revaluation Retrospective Management Ledger process - Execution Page Field Names and Description**

Field Name	Description or Instruction
Revaluation Rule Name	Enter the revaluation rule name as same present in the ERP system.
Rate Version	Enter the required exchange rate version.

**Note**

You can enter multiple rules for execution using commas as separators. Do not use spaces or other delimiters to ensure rules are processed sequentially.

7. To save the details and execute the Run, click **Execute**. The Run Execution begins.

**Note**

The execution of the Run Pipeline is triggered using the selected As of Date. See the [Managing Processes](#) Section for more details about the Processes.

8. To verify the Run Execution of the Balance Revaluation Retrospective Management Ledger Process, do the following:
- To open the **Process Monitor** Page, on the **Process Modeller** Page, click the **Process Monitor** Button or select **Process Flow Monitor** on the **Process** Menu on the **Process Modeller** Page.
  - The **Process Monitor** Page is displayed listing all the Run Instances corresponding to the Balance Retrospective Revaluation Management Ledger Process. On the **Process Monitor** Page, search by the Process ID, or by the Process Name Balance Revaluation Retrospective Management Ledger, and select the Process Instance for the required Run Pipeline (Process) that was executed.
9. The **Process Flow** Page is displayed with the Run Execution Status on each Node of the Balance Revaluation Retrospective Management Ledger Process.
10. To verify the Run Execution Logs, do the following:
- On the **Process Monitor** Page, click the required Process Instance for which you need to verify the Execution Logs.
  - To see the Execution Status details of a Node, double-click on that Node. The Execution Status details Page is displayed. Click **Execution Logs**.

The Log Viewer Page is displayed, which lists all the Logs related to the Process Instance. To see an elaborated information of a log entry, click the **Show More** Button. Click outside the Log Viewer Page to close it.

## 18.9 Revaluation Reversals

Reversals as instructed by revaluation metadata will be handled in AFCS by a Process Pipeline called 'Beginning Of The Day Balance Computation Management Ledger'. This

pipeline should be executed before the following business day's balance computation processes are, effectively as a Beginning of the Day process for the following business day.

**Note**

Information relevant for reversal processing will be held in the service no longer than two fiscal quarters.

**Note**

This applies only to reversals related to revaluation as instructed by the revaluation metadata.

- The Beginning of Day Process Pipeline will execute once at the beginning of each day.
- More than one Beginning of Day Process Pipeline should not be simultaneously executed with the same set of runtime parameters.
- The Beginning of Day Process Pipeline will support multiple ledgers and one legal entity at a time.

## 18.9.1 Use and Execute Beginning of the Day Balance Computation Management Ledger Pipeline

The Beginning of the Day Process Pipeline uses reversal journals and computes the daily movements and period-to-date process execution of average balances at the start of everyday.

To create and execute the Beginning of the Day Balance Computation Management Ledger process (Beginning of the Day Process Pipeline) in the Process Orchestration, do the following:

1. To access the Beginning of the Day Process Pipeline, on the Home Page, select the Process Orchestration.  
The Process Modeller Page is displayed.
2. On the Process Modeller Page, search and select the Beginning of the Day Balance Computation Management Ledger Pipeline.  
The Process Flow Page is displayed.
3. To execute the Run, you can select the Run Parameter values using the Execution icon on the Process page or on the Process Modeller page.
4. Navigate to the Process Modeller page to execute the Run and Click **Execution** icon.  
The **Execution** Page is displayed.
5. On the Execution page, to execute the Run with parameters, select With Parameters in the Execution Type List. Select or enter the required values for each field as follows:

**Table 18-13 Beginning of the Day Balance Computation Management Ledger Pipeline process - Execution page Field Names and Description**

Field Name	Description or Instruction
Extraction Date	Use the Calendar button to select the Extraction Date for the pipeline.
Ledger Name	Select the required Ledgers from the Available List for processing.
Legal Entity	Use the Link button to select atleast one Legal Entity from the Available Values List, move it to the Selected Values List, and click OK. <b>Note:</b> Do not select "All" option. <b>Note:</b> Do not select multiple legal entities. <b>Note:</b> Beginning of the Day Balance Computation Management Ledger process does not support Legal Entity or Data Source as filters. Select a valid Legal Entity for executing and processing data for all Legal Entities. <b>Note:</b> BCE computes all the Legal Entities irrespective of the Open or Closed status of the fiscal period.
Run execution Description	Enter the description for the run execution.

6. To save the details and execute the Run, click **Execute**. The Run Execution begins.

**Note**

The execution of the Run Pipeline is triggered using the selected Extraction Date.

7. To verify the Run Execution of the Beginning of the Day Balance Computation Management Ledger Pipeline process, do the following:
- To open the **Process Monitor** Page, on the **Process Modeller** Page, click the **Process Monitor** Button or select **Process Flow Monitor** on the **Process** Menu on the **Process Modeller** Page.
  - The **Process Monitor** Page is displayed listing all the Run Instances corresponding to the Beginning of the Day Balance Computation Management Ledger Pipeline process. On the **Process Monitor** Page, search by the Process ID, or by the Process Name Beginning of the Day Balance Computation Management Ledger Pipeline, and select the Process Instance for the required Run Pipeline (Process) that was executed.
8. The **Process Flow** Page is displayed with the Run Execution Status on each Node of the Beginning of the Day Balance Computation Management Ledger Pipeline process.
9. To verify the Run Execution Logs, do the following:
- On the **Process Monitor** Page, click the required Process Instance for which you need to verify the Execution Logs.
  - To see the Execution Status details of a Node, double-click on that Node. The Execution Status details Page is displayed. Click **Execution Logs**.

The Log Viewer Page is displayed, which lists all the Logs related to the Process Instance. To see an elaborated information of a log entry, click the **Show More** button. Click outside the Log Viewer page to close it.

## 18.10 Balance Computation Management Ledger Data Compaction Pipeline

The Balance Computation Management Ledger Data Compaction Pipeline is designed to compute and consolidate balances at the Management Ledger grain. This pipeline also removes old and redundant records from the processing entities of the Balance Computation module. This cleanup reduces data volume, streamlines processing, and significantly improves execution times for both processing runs and result area jobs. By maintaining only relevant and current data, the system ensures faster, more efficient balance computations and reporting.

### Note

- Execution of the Balance Computation Management Ledger Data compaction pipeline is optional and is **not mandatory** .
- The Balance Computation Management Ledger Data Compaction Pipeline, if executed, must be executed at the end in a non-critical execution window after all other pipelines such as Balance Computation Management Ledger and Balance Revaluation Management Ledger are executed for a day.
- Even if the execution is skipped for few dates, the Balance Computation Management Ledger Data compaction must be executed for the current or the latest MIS DATE only.
- Execution of the Balance Computation Management Ledger Data Compaction pipeline retrospectively is not supported.

### 18.10.1 Use and Execute Balance Computation Management Ledger Data Compaction Pipeline

The Balance Computation Management Ledger Data Compaction Pipeline streamlines balance computations and enhances the system performance within the AFCS. By removing the outdated and redundant records from processing entities, it reduces data volume and accelerates execution times for processing runs and result area jobs. This leads to faster financial reporting, improved scalability for high-volume environments.

To create and execute the Balance Computation Management Ledger Data Compaction process in the Process Orchestration, do the following:

1. To access the Balance Computation Management Ledger Data Compaction Pipeline, on the Home Page, select the Process Orchestration.  
The Process Modeller Page is displayed.
2. On the Process Modeller Page, search and select the Balance Computation Management Ledger Data Compaction Pipeline.  
The Process Flow Page is displayed.
3. To execute the Run, you can select the Run Parameter values using the Execution icon on the Process page or on the Process Modeller page.
4. Navigate to the Process Modeller page to execute the Run and Click **Execution** icon.  
The **Execution** Page is displayed.

5. On the Execution page, to execute the Run with parameters, select With Parameters in the Execution Type List. Select or enter the required values for each field as follows:

**Table 18-14 Balance Computation Management Ledger Data Compaction Pipeline - Execution page Field Names and Description**

Field Name	Description or Instruction
Extraction Date	Use the Calendar button to select the Extraction Date for the pipeline.
Run Purpose	Select the run purpose details from the drop down.

6. To save the details and execute the Run, click **Execute**. The Run Execution begins.

**Note**

The execution of the Run Pipeline is triggered using the selected Extraction Date.

7. To verify the Run Execution of the Balance Computation Management Ledger Data Compaction Pipeline, do the following:
  - a. To open the **Process Monitor** Page, on the **Process Modeller** Summary Page, select **Process Monitor** from the drop down menu.
  - b. The **Process Monitor** Page is displayed listing all the Run Instances corresponding to the Balance Computation Management Ledger Data Compaction Pipeline. On the **Process Monitor** Page, search by the Object ID, or by the Process Name Balance Computation Management Ledger Data Compaction Pipeline, and select the Object ID for the required Run Pipeline (Process) that was executed.
8. The **Process Flow** Page is displayed with the Run Execution Status on each Node of the Balance Computation Management Ledger Data Compaction Pipeline.
9. To verify the Run Execution Logs, do the following:
  - a. On the **Process Monitor** Page, click the required Object ID for which you need to verify the Execution Logs.
  - b. To see the Execution Status details of a Node, double-click on that Node. The Activity Execution Details Page is displayed. Click **Execution Logs**.

The Log Viewer Service Page is displayed, which lists all the Logs related to the Object ID. To download the execution log, click the **Download** button to download the file as a PDF or as an Excel sheet. Click **Close** to close the Log Viewer Service page.

## 18.11 Translation

Reporting Currency Ledgers are representations of a Primary or Secondary Ledger in another Currency for the Reporting purposes. The Reporting Currencies share the same Chart of Accounts, Accounting Calendar, and Accounting Method as their related Ledger. You can use the Reporting Currencies for Online Inquires, Reporting, and Consolidation.

Balance Translation is a part of the [Balance Computation Management Ledger Process](#).

**Note**

Balance computation processes in AFCS - journal ingestion, decomposition, revaluation and translation can be run incrementally multiple times a day. The service does not perform a check if such execution is requested, manually or via scheduling.

## 18.12 Support for Restatement

This Section provides information about the Support for Restatement (Backdated Run Execution) in the AFCS explicitly for the Start Date or End Date Attributes.

### 18.12.1 Overview

When a Regulatory Body asks a Bank or a Financial Institution to revise, make a correction, and re file the Report for a prior Reporting Period, the Restatement Support Feature can be used to correct and re file the Report. In the Restatement Support Feature, using the Data Version Property, the Bank or a Financial Institution can make the required modifications or add a few more data records to the Existing Report or delete the records from an Existing Report. The Start Date and End Date Attributes of Dimensions support the Backdated Run Execution. Out-of-the-box Run Pipelines are configured to use the Latest Record Indicator to select the appropriate Dimension Attributes irrespective of an Execution Date (Extraction Date). Therefore, the Start Date or End Date Attributes need to be used while rerunning the Report for a prior Date. A Backdated Run Execution for the Restatement Support is similar to a regular Run Execution.

#### Restatement of Ledger Balance and Movement Information

AFCS supports restatement of ledger information. 'Restatement' here refers to obtaining the latest balance and movement information for a retrospective date referring the latest as-of and effective dates. Please note that no specific process pipeline execution is necessary to handle backdated journals – journals that have effective date prior to a given as-of date. Once the journals are processed by balance computation process pipelines, should restatement be required, 'Balance Computation Management Ledger Incremental Results Area Load' pipeline should be executed. This pipeline will refresh Results as relevant. Please note that the process pipeline mentioned, 'Balance Computation Management Ledger Incremental Results Area Load', will incrementally update present and past dates' balance and movement information where relevant, as indicated by journals activity post reception from Financial Cloud and decomposition. Once concluded, the latest balance and movement information for retrospective effective dates and the latest will be available to access via reports and extracts. Please refer to [Result Entity](#) section in the *AFCS Data Catalog User Guide* for details on 'Balance Computation Management Ledger Incremental Results Area Load process pipeline'. Additionally, reference for reports and extracts are available from [Period to Date](#) and [OOTB Extract for Management Ledger As Of Effective Date](#), respectively.

#### 18.12.1.1 Data Identification Criteria

When the user executes a Balance Computation Process for a given As of Date, all the journal entries in the system for the said As of Date and the Posting Date less than the As of Date are considered for processing during the Restatement Process.

#### 18.12.1.2 Process Details

The Restatement Process works similar to the Daily Movement and Period Balance Computation on the basis of the Legal Entity, As of Date, Data Origin and GL Type. The

process runs for each posting date which lies between the earliest posting date for all journals of the specific GL Type. The process re-computes the Daily Movement and (or) the Period Balances for each journal entry identified as backdated for each date lying in the above specified range. The difference in treatment between GL Types is as follows:

- **Balance Sheet GL Types**  
The balances are added on the basis of Credit or Debit Vector of the journal entries and the process impacts the Daily Movements and Period Balances for all the dates lying within the above specified range.
- **Profit and Loss GL Types**  
The balances are summed up on the basis of the Credit or Debit Vector of the journal entries and the process impacts the Daily Movements for the specific dates for which backdated journals are identified. The process re-computes the period balances for all dates which lie within the above specified range.

The preceding process adds a new version of the existing record with the re-computed balances. This record also shows a difference in terms of the As of Date versus Posting Date (Effective Date) in the processing entities.

For an institution that does daily processing of the instrument-level balance, for illustration, a current- dated journal entry extracted and provided to OFSAA 15-August-2020 to be processed as of the same date, bears the following date values in the Example of Column Values, as supplied into the Accounting Entries Entity.

**Table 18-15 Details of the Date Fields in the Stage Accounting Entries Table**

Logical Column Name	Column Description	Example of Column Values
Extraction Date	This column stores the date as on which the snapshot of source data extracted for processing.	15-Aug-20
Transaction Date	This is the date of the transaction, which will always be the system date along with timestamp	As assigned by Systems of Record (Data Origin)
Value Date	This column stores the value date of the contract. Value date is the date on which the contract becomes effective.	As assigned by Accounting System
Transaction Posting Date	The date on which this transaction was posted against the associated account for monetary instruments and checks.	15-Aug-20
Processing Date	This is the process date of the transaction, which will be populated with current date of Branch Code.	15-Aug-20
Transaction Reversal Date	This column stores date of the transaction which is a reversal entry that made to cancel out a specific entry. These reversal entries are the entries that can be passed as a result of a cancelled transaction.	NULL

Balance Computation Management Ledger Process identifies prior-dated journal entries from the comparative combination of As of Date and Posting Date. When Posting Date is prior to As

of Date, Balance Computation Management Ledger Pipeline Processes Balance Sheet and Income Statement Ledger Account-types as follows:

- The Restatement Process works similar to the Daily Movement and Period Balance Computation Processes, by Legal Entity, As of Date, Data Origin and GL Type. Restatement is performed for each Posting Date between the earliest one for any journal entry of a specific GL Type and the present As of Date. The process re-computes the Daily Movement and (or) the Period Balances based on journal entries thus identified as backdated for each As of Date in the aforementioned date-range. The treatment of Balance Sheet and P&L:
  - **Balance Sheet Ledger Accounts:** The balances are summed up on the basis of Credit/Debit Vector of the journal entries and the process impacts the daily movements as well as period balances for all the dates lying within the above specified horizon.
  - **Profit & Loss Ledger Accounts:** The balances are summed up on the basis of the Credit/Debit Vector of the journal entries and the process impacts the daily movements for the specific dates for which backdated journals are identified. The process re-computes the period balances for all dates which lie within the above specified horizon.

## 18.13 Data Extraction for Management Ledger Period Balances

To extract the Data for "Management Ledger Period Balances" Entity, there are two processes that must be executed after creating a definition in the 'Data Extraction'. Once the Data Extraction is saved, the PMF process needs to be configured.

- Firstly, the Integration Management Ledger Balance Population must be executed- This integration process must be executed to derive the processed BCE output to Catalog. The applications can use the catalog output to derive reports and extract data.
- Secondly, execute the PMF process configured with the Data Extraction. For more details, see [Executing Connector Using Process Modelling Framework](#)

For more information on data Extraction and downloading the file, see [Data Extraction](#)

## 18.14 Data for Balance Reconciliation of Management Ledger Period Balances

This PMF run pipeline "Management Ledger Periodic Balance Population" must be executed to use the Management Ledger Period Balances data for reconciliation.

## 18.15 Initial Instrument - Grain Accounting Balance for Management Ledger

Initial balance for Management Ledger can be ingested through a data file and automated processes thereafter. The Initial balance figures should be provided with the General Ledger and the Customer Account Identification, alongside other relevant segment values as relevant to the General Ledger Chart of Accounts.

Initial balance information should be rendered through Accounting Entries Staging entity as follows:

- Balance against Asset, Expense and Contra-Liability GL account types should be flagged as DR journal lines.

- Balance against Liability, Revenue, Equity and Contra-Asset should be flagged as CR journal lines.

#### ① Note

1. Balance information should be provided designated in Entered and Functional currencies along with the corresponding code combination identifier from ERP.
2. Balance information should be provided through the Process Pipeline **Day Zero and Data Conversion Balance Computation** provided with the service. You should not select "0" or "MSG" option in the Data source field during execution of **Day Zero and Data Conversion Balance Computation** pipeline.
3. Initial balance information should only be ingested once.
4. Initial balance information provided is limited to day balance - Balance As-of-Date specified as the process-pipeline above is executed. The Period to Date and Period to Date Average Balance figures cannot be provided as part of the initial balance information.

## 18.15.1 Ingest Initial Balance

To ingest initial balance figures, please follow the steps below:

1. Prepare initial balance data as detailed above from appropriate sources. Please refer to the Catalog information on Accounting Entries entity and your choice of Chart of Account segments.

#### ① Note

Data for initialization of new ledgers or journals must be loaded with Accounting Entry Intent Indicator = I in the Stage Accounting Entries prior to the execution of **Day Zero and Data Conversion Balance Computation** pipeline.

#### ① Note

Execution of **Day Zero and Data Conversion Balance Computation** (that is any initialization of new ledgers or journals) must be done only after the execution of **Balance Computation Management Ledger** pipeline (if any) for a given day.

#### ① Note

All CCIDs represented in ERP GL should have been covered with ML-segments detail in AFCS during initialisation for each ledger covered by both, such that reconciliation post initialisation will pose no breaks.

2. Configure a Connector to load the initial balance data into Accounting Entries.
3. Execute the Data Quality checks on Accounting Entries according to the run-chart.
4. Execute the Process pipeline **Day Zero and Data Conversion Balance Computation**.

You should not select "0" or "MSG" option in the Data source field during execution of **Day Zero and Data Conversion Balance Computation** pipeline.

**Note**

**Day Zero and Data Conversion Balance Computation** process does not support Legal Entity or Data Source as filters. Select a valid Legal Entity for executing and processing data for all Legal Entities.

5. Prepare Access Management Ledger reports and validate initial balance information.

## 18.15.2 Processing History Prior to Live Production Use

AFCS facilitates ingestion of movement historical data and computation of balance based on it, without accounting rules or decomposition treatment.

This is in support of moving history data into AFCS. Post balance initiation, the movement history can be brought into AFCS and balance computed off it, without data moving through ERP FAH or being decomposed. The Stage accounting entries journals data is loaded into BCE directly and will bypass ERP and Decomposition. Balance Initialisation is required for balance initialization on the first instance of processing and users are expected to bring balances.

Processing history optionally happens post balance initialisation, subject to the approach being followed for switching AFCS and ERP to production use. Here, AFCS will support journal information at ML segments grain being supplied directly from a non-Oracle ERP source via Staging, which can then be used for balance computation. Such journal information can be withheld from publishing to ERP and all associated processes thereof. Such journals should carry segment values, GL CoA and ML, as they should be rendered, given no segment value lookup function in FAH will apply here.

**Prerequisite:** All BCE prerequisite steps must be completed before executing the pipeline.

**Note**

The **Day Zero and Data Conversion Balance Computation** pipeline will support incremental processing and can be executed multiple times in a day.

**Note**

All Accounting balance figures processed by this pipeline are as of a given MIS Date and Effective Date. This pipeline should be executed chronologically for contiguous dates through the fiscal year.

**Note**

Ensure that the Period to which you are executing **Day Zero and Data Conversion Balance Computation** process is an Open Period (locked) as set in the [Legal Entity Settings](#) section.

**Note**

The Fiscal Period locking check for the Legal Entity is enabled to verify the open or closed status prior to processing them.

**Note**

Even when there are no journals present for a particular day, the **Day Zero and Data Conversion Balance Computation** pipeline must be executed.

**Note**

AFCS requires that accounting balance information be initialised prior to processing transactions or journals data through the service, integrated with Oracle Financials Cloud. The following process pipeline should be used for initialisation purposes: **Day Zero and Data Conversion Balance Computation**.

Further to this, AFCS supports building of balance information for a subscriber-chosen period of time post initialisation date using appropriate journals data sourced for the purpose. This is an optional step that does not involve data flows between the service and Financials Cloud. The following process pipeline should be used for initialisation purposes: **Day Zero and Data Conversion Balance Computation**.

Please note that no ledger or portion thereof should be initialised more than once.

If the optional step of building balance information for a period of time post initialisation date without Financials Cloud involvement is being used:

- The balance computation processes involved should be run in chronological order
- Such processes should be run for contiguous dates

Once such activities of initialisation and building of balance information for a period of time are both completed, 'Regular' processing of transactions or journals through the service can commence. 'Regular' here refers to the flow of data from sources into AFCS and integrated data movements between the service and Financials Cloud. Once regular processing has started for a given ledger or portion thereof, no activities of initialisation or balance building without Financials Cloud involvement should be performed.

To process history data balances, follow the steps mentioned in the [Ingest Initial Balance](#) section.

**Note**

There will be no backdated journal balances processed during the execution.

# 19

## Balance Reconciliation

Balance Reconciliation reconciles the balances from the operational systems of a bank with the balances maintained in General Ledger (GL) of the bank. With AFCS, banks can also reconcile between General Ledgers maintained in the bank. The balances in the GL of a bank are the ones that are audited and duly certified by internal and external auditors. Hence, considered to be the final version of the truth in a bank. Therefore, all data extracted from any other operating system of a bank must be reconciled with the balances maintained in the GL to ensure they are complete, accurate, and comprehensive. It acts as an authentic and reliable base for any further decision-making.

The bank's operational data are sourced into standard product processor entities/tables. AFCS' GL Reconciliation has pre-configured GL/PP table GL code and corresponding balances, for which the reconciliation definition process must be executed. See 'Balance Reconciliation' for more information.

An option is available to reconcile GL data with other operational data used by the bank, which does not flow into the standard Product Processors configured in the application.

The Balance Reconciliation feature of AFCS supports reconciliation by the following dimensions, of which As-of Date, Accounting Standard, Account Currency, Legal Entity, and GL Account are mandatory.

**Table 19-1 Mandatory Dimensions**

<b>Dimension</b>
As-Of Date
Accounting Standard
Account Currency
Legal Entity
GL Account

**Table 19-2 Optional Dimensions**

<b>Dimension</b>
Business Unit
Organization Unit
Branch
Product
Project
Ledger Identifier
Counterparty
Account

**Note**

This set of dimensions corresponds to properties that are common across all product-processor and ledger balance data. Users can now include custom COA and ML segment dimensions (existing in the reconciliation entities) based on GL recon requirement.

Product Processors supported for Banking are:

- Stage Annuity Contracts
- Stage Bill Contracts
- Stage Borrowings
- Stage Cards
- Stage Casa
- Stage Futures Contracts
- Stage Foreign Exchange Contracts
- Stage Investments
- Stage Letter Of Credit Contracts
- Stage Leases Contracts
- Stage Loan Contracts
- Stage Over Draft Accounts
- Stage Option Contracts
- Stage Repo Contracts
- Stage Term Deposit Contracts
- Stage Swaps Contracts
- Stage Commitment Contracts
- Stage Merchant Cards
- Stage Credit Derivatives
- Stage Trusts
- Stage Correspondent Accounts
- Stage Prepaid Cards
- Stage Forwards Contracts

Insurance:

- Stage Health Insurance Contracts
- Stage Life Insurance Contracts
- Stage Retirement Account
- Stage Insurance Annuity Contracts
- Stage Property and Casualty Contracts

**Note**

In the AFCS Standard Edition, backward flow is not applicable and therefore Balance Reconciliation is not supported. For more information, see the [About Accounting Foundation Cloud Service- Standard Edition](#).

## 19.1 Measures List

Balance reconciliation uses the following product-processor amount figures as the measured values (measures) for comparison with ledger balance information.

**Note**

This set of dimensions corresponds to properties that are common across all product-processor and ledger balance data. It cannot be extended by users.

**Note**

Balance reconciliation requires that currency in which entered currency amount figures in Stage GL Data is designated matches the currency in which product processor and ML balance data is, as well.

**Table 19-3 Measure List for Banking Domain**

Catalog Entity	Measure	General Ledger code
Stage General Ledger Data	Amount In Accounting Currency	General Ledger Account Code
	Amount In Local Currency	General Ledger Account Code
	Monthly Average	General Ledger Account Code
	Balance Year To Date	General Ledger Account Code
Preparation Management Ledger Period Balance	Balance Year To Date	General Ledger Account Code
	Balance Year To Date in Local Currency	General Ledger Account Code
	Average Balance Month Till Date	General Ledger Account Code
	Average Balance Month To Date In Local Currency	General Ledger Account Code
Stage Annuity Contracts	Undrawn Amount	Undrawn General Ledger Code
	End of Period Balance	General Ledger Account Code
	Provision Amount	Provision General Ledger Code
Stage Repo Contracts	End Of Period Balance	General Ledger Account Code
	Provision Amount	Provision General Ledger Code
	Undrawn Amount	Undrawn General Ledger Code
	Current Write Off Amount	Write-Off General Ledger Code
Stage Option Contracts	End Of Period Balance	General Ledger Account Code
	Provision Amount	Provision General Ledger Code
	Total Fees And Charges	Fee General Ledger Code
	Undrawn Amount	Undrawn General Ledger Code
	Current Write Off Amount	Write-Off General Ledger Code

**Table 19-3 (Cont.) Measure List for Banking Domain**

Catalog Entity	Measure	General Ledger code
Stage Investments	End Of Period Balance	General Ledger Account Code
	Provision Amount	Provision General Ledger Code
	Undrawn Amount	Undrawn General Ledger Code
	Current Write Off Amount	Write-Off General Ledger Code
Stage Loan Contracts	Commission Amount	Commission General Ledger Code
	End Of Period Balance	General Ledger Account Code
	Total Fes And Charges	Fee General Ledger Code
	Current Write Off Amount	Write-Off General Ledger Code
Stage Casa	Commission Amount	Commission General Ledger Code
	End Of Period Balance	General Ledger Account Code
	Provision Amount	Provision General Ledger Code
	Total Fees And Charges	Fee General Ledger Code
Stage Cards	Current Write Off Amount	Write-Off General Ledger Code
	Commission Amount	Commission General Ledger Code
	End Of Period Balance	General Ledger Account Code
	Provision Amount	Provision General Ledger Code
Stage Term Deposit Contracts	Total Fees And Charges	Fee General Ledger Code
	Undrawn Amount	Undrawn General Ledger Code
	Current Write Off Amount	Write-Off General Ledger Code
	Commission Amount	Commission General Ledger Code
	End Of Period Balance	General Ledger Account Code
Stage Futures Contracts	Interest Accrued Amount Month Till Date	Accr Int General Ledger Code
	Total Fees And Charges	Fee General Ledger Code
	End Of Period Balance	General Ledger Account Code
	Provision Amount	Provision General Ledger Code
Stage Leases Contracts	Undrawn Amount	Undrawn General Ledger Code
	Current Write Off Amount	Write-Off General Ledger Code
	End Of Period Balance	General Ledger Account Code
	Total Fees And Charges	Fee General Ledger Code
Stage Bill Contracts	Undrawn Amount	Undrawn General Ledger Code
	Current Write Off Amount	Write-Off General Ledger Code
	Commission Amount	Commission General Ledger Code
	End Of Period Balance	General Ledger Account Code
Stage Letter of Credit Contracts	Provision Amount	Provision General Ledger Code
	Total Fees And Charges	Fee General Ledger Code
	Undrawn Amount	Undrawn General Ledger Code
	Commission Amount	Commission General Ledger Code
Stage Letter of Credit Contracts	End Of Period Balance	General Ledger Account Code
	Provision Amount	Provision General Ledger Code

**Table 19-3 (Cont.) Measure List for Banking Domain**

Catalog Entity	Measure	General Ledger code
Stage Borrowings	Total Fees And Charges	Fee General Ledger Code
	Undrawn Amount	Undrawn General Ledger Code
	Commission Amount	Commission General Ledger Code
Stage Foreign Exchange Contracts	End Of Period Balance	General Ledger Account Code
	Provision Amount	Provision General Ledger Code
	Undrawn Amount	Undrawn General Ledger Code
Stage Overdraft Accounts	End Of Period Balance	General Ledger Account Code
	Provision Amount	Provision General Ledger Code
	Undrawn Amount	Undrawn General Ledger Code
Stage Swaps Contracts	Total Fees And Charges	Fee General Ledger Code
	Current Write Off Amount	Write-Off General Ledger Code
	Commission Amount	Commission General Ledger Code
Commitment Contracts	End Of Period Balance	General Ledger Account Code
	Interest Accrued Amount Month Till Date	Accr Int General Ledger Code
	Provision Amount	Provision General Ledger Code
Correspondent Accounts	Undrawn Amount	Undrawn General Ledger Code
	Total fee and Charges	Fee General Ledger Code
	Current Write off Amount	Write-Off General Ledger Code
Credit Derivatives	Mark To Market Value In Natural Currency	General Ledger Account Code
	Market Value	General Ledger Account Code
	Provision Amount	Provision General Ledger Code
Forwards Contracts	Undrawn Amount	Undrawn General Ledger Code
	Unrealized Gain Or Loss	Unrealized General Ledger Code
	Realized Gain Or Loss Amount For The Period	Realized General Ledger Code
Merchant Cards	End Of Period Balance	General Ledger Account Code
	Undrawn Amount	Undrawn General Ledger Code
	Commission Amount	Commission General Ledger Code
Prepaid Cards	End Of Period Balance	General Ledger Account Code
	Provision Amount	Provision General Ledger Code
	Current Write Off Amount	Write-Off General Ledger Code
Trusts	End Of Period Balance	General Ledger Account Code
	End Of Period Balance	General Ledger Account Code
	End Of Period Balance	General Ledger Account Code

**Table 19-4 Measure List for Insurance Domain**

Entity_Name	Measure_Name	Corresponding GL Code
Stage General Ledger Data	Amount In Accounting Currency	General Ledger Account Code

Table 19-4 (Cont.) Measure List for Insurance Domain

Entity_Name	Measure_Name	Corresponding GL Code
Preparation Management Ledger Period Balance	Amount In Local Currency	General Ledger Account Code
	Yearly Average	General Ledger Account Code
	Monthly Average	General Ledger Account Code
	Balance Year To Date	General Ledger Account Code
	Balance Year To Date in Local Currency	General Ledger Account Code
	Average Balance Month Till Date	General Ledger Account Code
	Average Balance Month To Date In Local Currency	General Ledger Account Code
Health Insurance Contracts	Policy Fee Amount	Policy Fee General Ledger Code
	Premium Due Amount	Premium Due General Ledger Code
	Premium Waived Amount	Premium Waived General Ledger Code
	Ceded Premium Amount	Ceded Premium General Ledger Code
	Premium Overdue Amount	Premium Due General Ledger Code
	Separate Account Value	Separate Account General Ledger Code
	Reinsurance Premium Charges	Reinsurance Premium General Ledger Code
Insurance Annuity Contracts	Underwriter Expense Amount	Underwriter Expense General Ledger Code
	Ceded Premium Amount	Ceded Premium General Ledger Code
Life Insurance Contracts	Premium Overdue Amount	Premium Due General Ledger Code
	Policy Fee Amount	Policy Fee General Ledger Code
	Premium Due Amount	Premium Due General Ledger Code
	Premium Waived Amount	Premium Waived General Ledger Code
	Outstanding Balance Of Loan Linked To The Policy	Outstanding Policy Loan General Ledger Code
	Ceded Premium Amount	Ceded Premium General Ledger Code
	Premium Overdue Amount	Premium Due General Ledger Code
	Separate Account Value	Separate Account General Ledger Code
	Underwriter Expense Amount	Underwriter Expense General Ledger Code
	Reinsurance Premium Charges	Reinsurance Premium General Ledger Code
Retirement Accounts	Ceded Premium Amount	Ceded Premium General Ledger Code
	Premium Due Amount	Premium Due General Ledger Code

Table 19-4 (Cont.) Measure List for Insurance Domain

Entity_Name	Measure_Name	Corresponding GL Code
	Premium Overdue Amount	Premium Due General Ledger Code
	Separate Account Value	Separate Account General Ledger Code
Property And Casualty Contracts	Policy Fee Amount	Policy Fee General Ledger Code
	Premium Due Amount	Premium Due General Ledger Code
	Premium Waived Amount	Premium Waived General Ledger Code
	Underwriter Expense Amount	Underwriter Expense General Ledger Code
	Premium Overdue Amount	Premium Due General Ledger Code
	Ceded Premium Amount	Ceded Premium General Ledger Code
	Reinsurance Premium Charges	Reinsurance Premium General Ledger Code

## 19.1.1 Enable Custom Measures

Beginning with AFCS 23D, the use of new measures for GL-PP Reconciliation is supported. You can map a custom Amount (numeric) measure to the GL code when a custom extension is completed. Custom measures can now be selected for GL-PP and ML-PP Reconciliation but not for GL-ML Reconciliation.

To enable a new measure:

1. Create an issue by selecting **Catalog Extension** as the **Category** and **Catalog** as the **Source**. See [Create or Log an Issue](#) to know how to create an issue.
2. Create an action for the issue you just created by selecting **Catalog Extension** as the Action Type. See [Create an Action](#) to know how to create an action.
3. Navigate to the action you just created and navigate to **Extension** tab and select **Create Business Term** option.
4. In the **Definition** screen, enter the **Business Term Logical Name**, select **Classification** and **Logical Data Type** based on your requirements and click **Add**.
5. In the **Relationships** screen, click **Add** and enter **GR2** under **Group Code** field and select the **Relationship Type** as **Measure GL** and select the required code in the **Related Business Term** drop-down.

### Note

After Catalog extension, under the **Relationship** tab, user has to configure the measures (Either Out-of-the-Box or custom measures) to perform reconciliation.

6. Navigate to **Definition** screen and click **Save**.
7. In the **Extension** tab, click Submit and Approve.

8. Navigate to **Administration** and click **Publish Change Request Approved** tab and select the action you just created and click **Publish**. To view the status of the approval, navigate to **Published** tab.
9. Create a new Action and navigate to **Extension** tab and select **Extend Fact** option. See [Create an Action](#) to know how to create an action.
10. In the **Extend Fact Entity** screen, select **Grain** as **Customer Account**, select the **Entities** and **Business Terms** which you want to extend and click **Save**. The custom created Business term is displayed here.
11. In the **Extension** tab, click Submit and Approve.
12. Navigate to **Administration** and click **Publish Change Request Approved** tab and select the action you just created and click **Publish**. To view the status of the approval, navigate to **Published** tab.
13. Navigate to the **Entity** screen and map the new measure to the respective Product Processor.  
The custom measure is mapped to the Product Processor.

## 19.2 Before you Begin

Select the **Domain** and **Deploy** the selected domain.

## 19.3 Access Balance Reconciliation UI

To access Balance Reconciliation, perform these steps:

1. From the **Oracle Financial Services Accounting Foundation Cloud** page, click and select your Subledger application.
2. Click **Balance Reconciliation**.  
The **Type** details for the selected Subledger application are displayed.

### Note

For the fresh provisioning, follow the below steps:

- Click on **Refresh Metadata** in Type screen.
- Wait for the Refresh Metadata to get completed and marked as DONE with a tick mark.

3. You can click the following tabs to view more details:
  - **Entity**
  - **Reconciliation Rule**
  - **Reconciliation Summary**
  - **Adjustments**

## 19.4 Configure Type of Reconciliation

GL to PP and GL to ML reconciliation are supported. For GL to PP reconciliation, Source GL is mapped to target PP tables, and in the case of GL to ML reconciliation, Source GL is mapped to target ML table. Mandatory dimensions are preselected but you can define additional

dimensions. Mandatory dimensions, optional dimensions, and MEMBERS OF THE DIMENSION participate in the GL Reconciliation process.

On the **Type** configuration page, the predefined Reconciliation Definition types that can be used during a Reconciliation Definition are displayed:

- General Ledger to Product Processor
- General Ledger to Management Ledger
- Management Ledger to Product Processor
- General Ledger to Policy

**Note**

"GL Code for Reconciliation" as an optional dimension is not expected to be used in any of the Reconciliation types.

## 19.4.1 Type Configuration

While configuring the Type, you define the type of reconciliation. You can click the **Type** tab and perform the following tasks for the selected reconciliation type:

- View



: Click the View icon to view the Settings and Dimensions of the selected reconciliation type as read-only.

- Edit



: Click the Edit icon to modify the Settings and Dimensions details of the selected reconciliation type. You can modify the existing reconciliation definition except its name.

**Topics:**

- General Ledger to Product Processor
- General Ledger to Management Ledger
- Management Ledger to Product Processor

### 19.4.1.1 General Ledger to Product Processor

General Ledger to Product Processor Reconciliation identifies the difference between GL system and Product Processor data. It nullifies the difference by posting the adjustment entries up to the amount of difference.

- If the reconciliation difference is greater than the threshold value, the difference is reported.

- A threshold is a specified Product Processor level and these values are specified as a percentage or an absolute amount. The percentage value represents the difference in percent to the General Ledger side amount.
- If the threshold is specified as an amount, it must be read in connection with a currency of the threshold amount. The reconciliation difference is reported in the base currency. If the currency specified here is different from that of the reconciliation dimension, the difference amount must be converted in the threshold currency using the exchange rate of execution date or the latest available rate of the five preceding days.
- While reconciling General Ledger and Product Processor, differences can arise in two ways:  
When the General Ledger Amount is greater than the Product Processor Amount  
OR  
When the General Ledger amount is less than the Product Processor amount.
- Therefore, there are two threshold values to address differences arising out of this condition. For more information, see Target Parameters.  
**Topics:**
  - Settings
  - Dimensions

#### 19.4.1.1.1 Settings

The **Settings** tab displays the name and the description of the General Ledger to Product Processor Configuration reconciliation type.

- **Source:** Displays the Source Grain and the Source Entity for the General Ledger to Product Processor type. The Stage General Ledger data is the default source entity used for reconciliation definition.
- **Target:** Displays the Target Grain and Target Entity for General Ledger to Product Processor type. The Target entities refer to the Stage instrument tables (Product Processors) of the Oracle Financial Services Data Foundation.

#### 19.4.1.1.2 Dimensions

Use the Dimensions tab to configure **Dimension Mappings** and **Dimension Attribute Selection**. **Legal Entity**, **Currency**, and **GAAP Code** are mandatory dimensions you must select to proceed with GL Reconciliation executions.

##### Note

It is assumed that mandatory reconciliation dimensions are present in all the bank's GL source systems.

- **Dimension Mappings:** Displays the Legal Entity, Currency, and Accounting Standard for the selected dimension. You can configure additional optional dimensions based on your requirements.
- **Dimension Attribute Selection:** You can map the respective dimension attribute to each of the entities selected under **Settings**. For example: the Stage Cards, Stage General Ledger Data, and Stage Loan Contracts have been configured for dimensions.

**Note**

'Business Unit Code' dimension is not applicable for the Stage Merchant Cards and the 'Organization Unit Code' dimension is not applicable for Stage Prepaid Cards.

**Note**

You can choose the 'Financial Element' dimension for the reconciliation types that have 'Stage General Ledger Data' as the source and it must be added as a filter and not as an option while configuring dimensions in the respective reconciliation types.

**Note**

The Dimensions tab functionalities remain the same for all three types of configurations.

### 19.4.1.1.3 Editing Dimensions

By default, **Legal Entity**, **Currency**, and **Accounting Standard** are available. You can also select optional dimensions such as Product and Organization Unit by selecting from the **Dimension** list.

When you select an option from the **Dimension** list, mapping for all the entities selected in the **Settings** tab is performed.

Only a Legal Entity dimension must be selected against the Legal Entity. You are expected to select a valid Legal Entity, GAAP, and Currency hierarchy while configuring the mandatory dimensions.

You can select one or more entities to map the attributes to the respective dimension.

1. Select any of the entities under **Dimension Attributes Selection** to enable the Attributes icon. Click the Attributes icon to add optional Dimension Attributes. The **Attributes List** displays the list of the attributes that can be associated with the selected Dimension Attributes. This list displays the combined attributes for all the Stage Tables selected.
2. Select the attributes and click **OK**.

### 19.4.1.2 General Ledger to Management Ledger

Management Ledger refers to an entity with detailed GL balances based on number of COA segments chosen, often referred to as thick GL. In this setting, the Balance Computation engine output data is tagged as Management Ledger data.

In AFCS, the Management Ledger Reconciliation compares Source GL Data with Target revalued balance of the Balance Computation engine. While the source GL data is ingested from Accounting Hub Cloud Service (AHCS), target data is output for the Balance computation engine. GL Level Definition is only enabled during management ledger reconciliation.

The Reconciliation Type **General Ledger to Management Ledger** helps reconcile such balances. Navigate to Reconciliation Type to see the out of the box configuration of this type of reconciliation.

In the General Ledger to Management Ledger (GL to ML) reconciliation, the difference between two sources of the Ledger for the same Legal Entity and the Consolidation Type is identified. This difference is identified at the granularity of the GL code for the selected hierarchy, mandatory dimensions, and the selected optional dimensions. Adjustments are not passed in this reconciliation. Additionally, the difference is identified by comparing the Source Ledger with the Target Ledger to ensure that all the GL codes' amount is covered to calculate the difference.

A Legal Entity in the bank can maintain the same GL data (either solo or consolidated) in one or more source systems. If GL data is maintained in the multiple source systems, then it is essential to compare the GL balances among such GL sources to ensure that all GL sources reflect accurate and uniform balance. Any difference between two GL source systems is expected to be rectified outside the framework. Reconciliation definition is applied at Legal Entity Level: Solo or Consolidated.

**Note**

The predefined dimensions such as Project Code, Ledger Identifier, Counterparty, and Intercompany Identifier are applicable only for General Ledger to Management Ledger Type Configuration.

**Note**

The Adjustment Entry is not passed in the GL to ML reconciliation.

**Note**

The Management Ledger Period Balance is included in the data model of the AFCS Reconciliation Framework. This table is used as a Target Ledger table. The Preparation Management Ledger Period Balance is a single table to store the thick ledger of the bank and it is already configured.

**Topics:**

- Settings
- Dimensions

### 19.4.1.2.1 Settings

The Settings tab displays the name and the description of the General Ledger to Management Ledger reconciliation type.

- **Source:** Displays the Source Grain (Ledger) and the Source Entity for General Ledger to Management Ledger. The Stage General Ledger data is the default source entity used for reconciliation definition.
- **Target:** Displays the Target Grain (Management Ledger) and Target Entity for General Ledger to Management Ledger. The Target entities refer to the Preparation Management Ledger Period Balance table (Management Ledger) of the Oracle Financial Services Data Foundation.

### 19.4.1.2.2 Dimensions Section

Use the Dimensions tab to configure **Dimension Mapping** and **Dimension Attribute Selection**. **Legal Entity**, **Currency**, and **Accounting Standard** are mandatory dimensions you must select to proceed with GL Reconciliation executions.

#### Note

It is assumed that mandatory reconciliation dimensions are present in all the bank's GL Source Systems.

- **Dimension Mapping:** Displays the Legal Entity, Currency, and Accounting Standard for the selected dimension. You can configure additional optional dimensions based on your requirements.
- **Dimension Attribute Selection:** You can map the respective dimension attribute to each of the entities selected under **Settings**. The Stage General Ledger Data, and Preparation Management Ledger Period Balance have been configured for dimensions.

#### Note

Reconciliation Framework follows attribute consistency. It is expected that the same attribute is used for a particular dimension across all the Stage entities. For example, if **Product Code** is used for product dimension, the system will always look for **Product Code** in all the stage-side entities (General Ledger and Management Ledger).

In the View mode, the corresponding mappings of the entities present in the **Dimension Mapping** pane are displayed with the selected dimension attributes in a Read-Only mode.

#### Note

You can choose the 'Financial Element' dimension for the reconciliation types that have 'Stage General Ledger Data' as the source and it must be added as a filter and not as an option while configuring dimensions in the respective reconciliation types.

#### Note

The Dimensions tab functionalities remain the same for all three types of configurations.

### 19.4.1.2.3 Editing Dimension

By default, **Legal Entity**, **Currency**, and **Accounting Standard** are available. You can also select optional dimensions such as Product and Organization Unit by selecting from the **Dimension** list.

When you select an option from the **Dimension** list, mapping for all entities selected in the **Settings** tab is performed.

Only a Legal Entity dimension must be selected against Legal Entity. You are expected to select a valid Legal Entity, and Currency hierarchy while configuring the mandatory dimensions.

You can select one or more entities to map the attributes for the respective dimension.

1. Select any of the entities under **Dimension Attributes Selection** to enable the Attributes icon. Click the Attributes icon to add optional Dimension Attributes. The **Attributes list** displays the list of the attributes that can be associated with the selected Dimension Attributes. This list shows the combined attributes for all the Stage Tables selected.
2. Select the attributes and click **OK**.

### 19.4.1.3 Management Ledger to Product Processor

The General Ledger Data will be ingested from Accounting Hub Cloud Services (AHCS) into GL Ledger table in Accounting Foundation Cloud Services (AFCS). The Product Processor (PP) table will be ingested from the external data source. BCE data is the output of the Balance Compute Engine generated balances from Journal and Transaction entries.

**Figure 19-1 Management Ledger to Product Processor workflow**

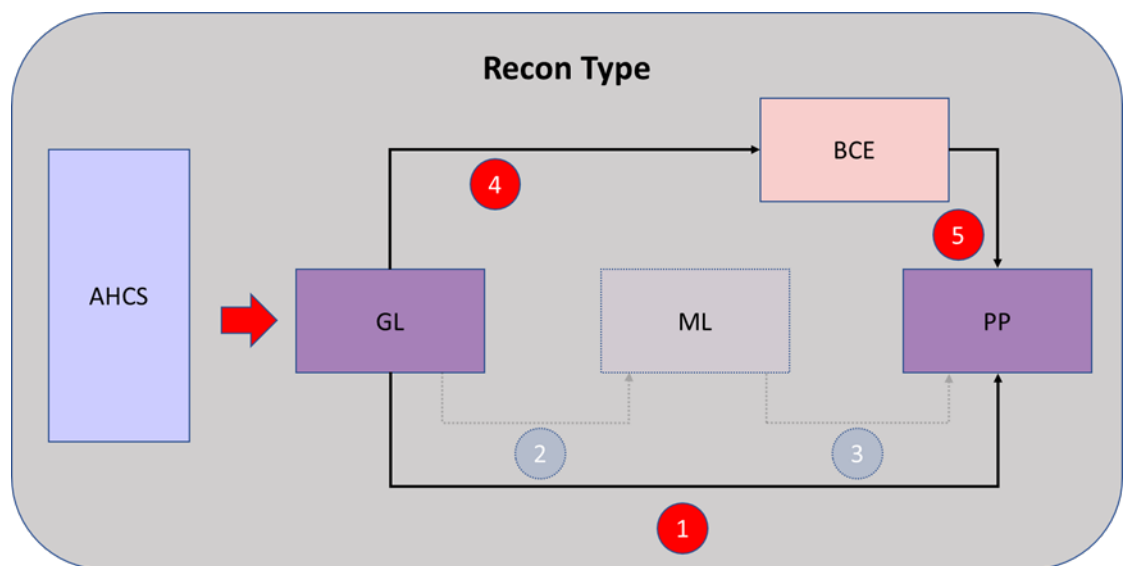

The BCE revalued output data to be reconciled against General Ledger data and Product Processor data as shown in above diagram 4 and 5.

The Management Ledger to Product Processor Reconciliation identifies the difference between ML system and Product Processor data. It nullifies the difference by posting the adjustment entries up to the amount of difference.

- If the reconciliation difference is greater than the threshold value, the difference is reported.
- A threshold is a specified Product Processor level and these values are specified as a percentage or an absolute amount. The percentage value represents the difference in percent to the Management Ledger side amount.

- If the threshold is specified as an amount, it must be read in connection with a currency of the threshold amount. The reconciliation difference is reported in the base currency. If the currency specified here is different from that of the reconciliation dimension, the difference amount must be converted in the threshold currency using the exchange rate of execution date or the latest available rate of the five preceding days.
- While reconciling Management Ledger and Product Processor, differences can arise in two ways:  
When the Management Ledger Amount is greater than the Product Processor Amount.  
OR  
When the Management Ledger amount is less than the Product Processor amount.
- Therefore, there are two threshold values to address differences arising out of this condition. For more information, see Target Parameters.

**Note**

Management Ledger to Policy is not supported for Insurance domains.

**Note**

The predefined dimension, Account is applicable only for Management Ledger to Product Processor Type Configuration.

**Topics:**

- Settings
- Dimensions

### 19.4.1.3.1 Settings

The Settings tab displays the name and the description of the Management Ledger to Product Processor reconciliation type.

- **Source:** Displays the Source Grain (Management Ledger) and the Source Entity for Management Ledger to Product Processor. The Preparation Management Ledger Period Balance is the default source entity used for reconciliation definition.
- **Target:** Displays the Target Grain (Product Processor) and Target Entity for Management Ledger to Product Processor. The Target entities refer to the Preparation Management Ledger Period Balance table (Product Processor) of the Oracle Financial Services Data Foundation.

### 19.4.1.3.2 Dimensions Section

Use the Dimensions tab to configure **Dimension Mapping** and **Dimension Attribute Selection**. The **Currency**, **Legal Entity** and **Accounting Standard** are mandatory dimensions you must select to proceed with GL Reconciliation executions.

**Note**

It is assumed that mandatory reconciliation dimensions are present in all the bank's GL Source Systems.

- **Dimension Mapping:** Displays the Legal Entity, and Accounting Standard for the selected dimension. You can configure additional optional dimensions based on your requirements.
- **Dimension Attribute Selection:** You can map the respective dimension attribute to each of the entities selected under **Settings**. The Stage Legal Entity Code for Stage Loan Contracts and Legal Entity Code for Stage Cards have been configured for dimensions.

**Note**

'Business Unit Code' dimension is not applicable for the Stage Merchant Cards and the 'Organization Unit Code' dimension is not applicable for Stage Prepaid Cards.

**Note**

Reconciliation Framework follows attribute consistency. It is expected that the same attribute is used for a particular dimension across all the Stage entities. For example, If **Product Code** is used for product dimension, the system will always look for **Product Code** in all the stage-side entities (Management Ledger to Product Processor).

In the View mode, the corresponding mappings of the entities present in the **Dimension Mapping** pane are displayed with the selected dimension attributes in a Read-Only mode.

**Note**

The Dimensions tab functionalities remain the same for all three types of configurations.

**Topics:**

- Editing Dimension

### 19.4.1.3.3 Editing Dimension

By default, **Legal Entity**, **Currency**, and **Accounting Standard** are available. You can also select optional dimensions such as Product and Organization Unit by selecting from the **Dimension** list.

When you select an option from the **Dimension** list, mapping for all entities selected in the **Settings** tab is performed.

Only a Legal Entity dimension must be selected against Legal Entity. You are expected to select a valid Legal Entity, and Currency hierarchy while configuring the mandatory dimensions.

You can select one or more entities to map the attributes for the respective dimension.

1. Select any of the entities under **Dimension Attributes Selection** to enable the Attributes icon. Click the Attributes icon to add optional Dimension Attributes. The **Attributes list** displays the list of the attributes that can be associated with the selected Dimension Attributes. This list shows the combined attributes for all the Stage Tables selected.
2. Select the attributes and click **OK**.

### 19.4.1.4 General Ledger to Policy

Balance Reconciliation framework is enhanced for the Insurance domain and it supports the following reconciliation types such as General Ledger to Management Ledger and General Ledger to Policy. General Ledger to Management Ledger reconciliation type process remains the same, and the new Reconciliation Type “General Ledger to Policy Type” includes all the Insurance entities to be configured for reconciliation. The insurance entities configured in General Ledger to Policy Reconciliation Type are currently limited to Policy grain.

#### 19.4.1.4.1 Settings

The Settings tab displays the name and the description of the General Ledger to Policy reconciliation type.

- **Source:** Displays the Source Grain (Ledger) and the Source Entity for General Ledger to Policy. The Stage General Ledger data is the default source entity used for reconciliation definition.
- **Target:** Displays the Target Grain (Policy) and Target Entity for General Ledger to Policy. The Target entities refer to the Policy entity table (Policy) of the Oracle Financial Services Data Foundation.

#### Note

You must add the following domains to view the them under the target entity:

- Health Insurance
- Life Insurance
- Retirement
- Annuity
- Property and Casualty

#### 19.4.1.4.2 Dimensions Section

Use the Dimensions tab to configure **Dimension Mapping** and **Dimension Attribute Selection**. **Legal Entity**, **Currency**, and **Accounting Standard** are mandatory dimensions you must select to proceed with GL Reconciliation executions.

#### Note

It is assumed that mandatory reconciliation dimensions are present in all the bank's GL Source Systems.

- **Dimension Mapping:** Displays the Legal Entity, Currency, and Accounting Standard for the selected dimension. You can configure additional optional dimensions based on your requirements.
- **Dimension Attribute Selection:** You can map the respective dimension attribute to each of the entities selected under **Settings**. For example: Stage General Ledger Data, Stage Health Insurance Contracts, Stage Retirement Accounts, Stage Life Insurance Contracts, Stage Property and Casualty Contracts have been configured for dimensions.

**Note**

'Branch' dimension is not applicable for Stage Retirement Accounts.

**Note**

You must map the Dimension attribute which is available in both source and the target entities.

**Note**

You can choose the 'Financial Element' dimension for the reconciliation types that have 'Stage General Ledger Data' as the source and it must be added as a filter and not as an option while configuring dimensions in the respective reconciliation types.

The Dimensions tab functionalities remain the same for all four types of configurations.

### 19.4.1.4.3 Editing Dimension

By default, **Legal Entity**, **Currency**, and **Accounting Standard** are available. You can also select optional dimensions such as Product and Organization Unit by selecting from the **Dimension** list.

When you select an option from the **Dimension** list, mapping for all entities selected in the **Settings** tab is performed.

Only a Legal Entity dimension must be selected against Legal Entity. You are expected to select a valid Legal Entity, and Currency hierarchy while configuring the mandatory dimensions.

You can select one or more entities to map the attributes for the respective dimension.

1. Select any of the entities under **Dimension Attributes Selection** to enable the Attributes icon. Click the Attributes icon to add optional Dimension Attributes. The **Attributes list** displays the list of the attributes that can be associated with the selected Dimension Attributes. This list shows the combined attributes for all the Stage Tables selected.
2. Select the attributes and click **OK**.

### 19.4.1.5 Management Ledger to Policy

Balance Reconciliation framework is enhanced for the Insurance domain and it supports the following reconciliation types such as General Ledger to Management Ledger, General Ledger to Policy, and Management Ledger to Policy. General Ledger to Management Ledger

reconciliation type process remains the same, and the new Reconciliation Type “Management Ledger to Policy Type” includes all the Insurance entities to be configured for reconciliation. The insurance entities configured in Management Ledger to Policy Reconciliation Type are currently limited to Policy grain.

### 19.4.1.5.1 Settings

The Settings tab displays the name and the description of the Management Ledger to Policy reconciliation type.

- **Source:** Displays the Source Grain (Management Ledger) and the Source Entity for Management Ledger to Policy. The Preparation Management General Ledger Period Balance is the default source entity used for reconciliation definition.
- **Target:** Displays the Target Grain (Policy) and Target Entity for Management Ledger to Policy. The Target entities refer to the Policy entity table (Policy) of the Oracle Financial Services Data Foundation.

#### Note

You must add the following domains to view the them under the target entity:

- Health Insurance
- Life Insurance
- Retirement
- Annuity
- Property and Casualty

### 19.4.1.5.2 Dimensions Section

Use the Dimensions tab to configure **Dimension Mapping** and **Dimension Attribute Selection**. **Legal Entity**, **Currency**, and **Accounting Standard** are mandatory dimensions you must select to proceed with GL Reconciliation executions.

#### Note

It is assumed that mandatory reconciliation dimensions are present in all the bank's GL Source Systems.

- **Dimension Mapping:** Displays the Legal Entity, Currency, and Accounting Standard for the selected dimension. You can configure additional optional dimensions based on your requirements.
- **Dimension Attribute Selection:** You can map the respective dimension attribute to each of the entities selected under **Settings**. For example: Preparation Management Ledger Period Balance, Stage Insurance Annuity Contracts, Stage Health Insurance Contracts, Stage Retirement Accounts, Stage Life Insurance Contracts, Stage Property and Casualty Contracts have been configured for dimensions.

**Note**

'Branch' dimension is not applicable for Stage Retirement Accounts.

**Note**

You must map the Dimension attribute which is available in both source and the target entities.

The Dimensions tab functionalities remain the same for all five types of configurations.

### 19.4.1.5.3 Editing Dimension

By default, **Legal Entity**, **Currency**, and **Accounting Standard** are available. You can also select optional dimensions such as Product and Organization Unit by selecting from the **Dimension** list.

When you select an option from the **Dimension** list, mapping for all entities selected in the **Settings** tab is performed.

Only a Legal Entity dimension must be selected against Legal Entity. You are expected to select a valid Legal Entity, and Currency hierarchy while configuring the mandatory dimensions.

You can select one or more entities to map the attributes for the respective dimension.

1. Select any of the entities under **Dimension Attributes Selection** to enable the Attributes icon. Click the Attributes icon to add optional Dimension Attributes. The **Attributes list** displays the list of the attributes that can be associated with the selected Dimension Attributes. This list shows the combined attributes for all the Stage Tables selected.
2. Select the attributes and click **OK**.

## 19.5 Configure Entity

Use the **Entity** tab to set and maintain metadata related to Reconciliation Rules. This is a one-time activity and defines the boundaries of GL Reconciliation. Entity configuration includes the Reconciliation of Entities in the GL Reconciliation Process.

**Note**

The Entities screen consists of predefined data. You can view, edit, or delete the Reconciliation Entities using this predefined data. The Entity list is pre-seeded. However, you can change the **Dataset** to **Measures** mapping.

### 19.5.1 Entity Configuration

On the **Entity** screen, you will see a list of settings with the following information:

- **Entity Name:** The name of the Reconciliation Entity.

- **Grain:** The granularity of data within the entity. For example: Ledger, Account, or Management Ledger.
- **Dataset:** Add the Dataset from the drop-down list for the selected Entity.

You can view, edit, or delete a selected entity.

- **View:**



Click the View icon, to view details of the entity in the Read-Only mode.

- **Edit:**



Click the Edit icon to modify the **DataSet** to **Measures** mapping for this entity.

**Note**

For more information, see the list of Measures.

## 19.6 Reconciliation Rules

**Topics:**

- Define Reconciliation Rules
- Executing the Rule
- Reconciliation Summary

### 19.6.1 Define Reconciliation Rules

Reconciliation Management is the designated level at which the account balances are reconciled in the system. Information that specifies the granular level at which account balances are reconciled across one or many entities is stored.

GL to PP Reconciliation is performed at the following levels:

- **GL Level Reconciliation:** The difference between the GL System and the Product Processor systems at each reconciliation dimension node level within a GL Code is identified.
- **Map Level Reconciliation:** The difference between the GL Data and the Product Processor Data at each reconciliation Dimension Node Level across all the Product Processors are identified.

GL to PP Reconciliation can be defined using Manual Reconciliation Definition.

For a detailed explanation of GL Level Recon and Map Level Recon, see the 'Key Terms and Concepts' section.

**Topics:**

- Reconciliation Page
- Search Reconciliation Rule
- Add a Reconciliation Definition

### 19.6.1.1 Reconciliation Rule

On the AFCS Home page, select a Subledger application and click its **Balance Reconciliation** link. Then click **Reconciliation Rules** on the LHS menu to access the Reconciliation Rules screen.

Use the **Thumb** and **List** view icons to control how you want to view the Reconciliation Rules. Use the **Search** bar to search for a Reconciliation Rule.

To add or edit a Reconciliation Rule, you must provide information grouped under the following:

- Settings
- GL Parameters
- Target Parameters
- Dimension
- Allocation

#### Note

Allocation settings are not applicable when the Reconciliation Type is **General Ledger to Management Ledger**.

You can **View** (in Read-Only mode), **Edit**, **Copy**, or **Delete** Reconciliation Rules. Use the **Add** button to add a new Reconciliation Rule.

- **Add:**

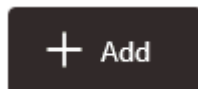

Click the Add icon to begin the process of adding a new Reconciliation Rule.

- **View:**



To view a reconciliation definition (in read-only mode), click the View icon corresponding to that definition.

- **Edit:**



To modify a reconciliation definition, click the Edit icon corresponding to that definition. The **Legal Entity** and **Consolidation Type** fields are disabled while you edit a reconciliation definition.

- **Copy:**



To copy a reconciliation definition, click the Copy icon corresponding to that definition. Provide a **Name** and **Description**. Navigate through the remaining tabs to modify the settings per your requirement and **Save** your details to create a new reconciliation definition.

- **Delete:**



To delete a reconciliation definition, click the Delete icon corresponding to that definition.

## 19.6.1.2 Search Reconciliation Rule

Use the **Search** bar to search for any reconciliation rule.

### Prerequisites

Predefined Reconciliation Rule

### Procedure

To search a reconciliation rule, follow these steps:

1. Navigate to the **Reconciliation Rules** screen.
2. Enter the search criteria in the **Search** bar and click **GL Level Recon** or **Map Level Recon**.
3. The search results are displayed in the **List** view.

### 19.6.1.2.1 Definition List

The definition list displays all the reconciliation rule definitions that match your search criteria.

In the **Thumb View**, the following information is displayed:

- **Measures:** The number of measures defined in the Reconciliation Rule.
- **GL Accounts:** The number of GL Codes users have selected in the Reconciliation Definition.
- **Consolidation:** The **Consolidation Type:** **Solo** or **Consolidated**.
- **Adjustment:** Displayed as **Yes** or **No** depending on whether the Adjustment Allocation has been applied to the selected reconciliation definition or not.

## 19.6.1.3 Add a Reconciliation Definition

To add the reconciliation definition, follow these steps:

On the Reconciliation Rules **Summary** screen, click the **Add** icon. The **Add Rule** tab appears where you can provide the following information:

- Settings
- GL Parameters (Source Ledger Parameters)

- Target Parameters
- Dimensions
- Allocation

### 19.6.1.3.1 Settings

To create the reconciliation definition, enter or select the following details in the **Settings** tab.

1. Enter or select the following details in the **Settings** tab:
  - **Rule Name:** Enter the **Rule Name** . This is mandatory information.
  - **Rule Description:** Enter a brief description for the rule. This is mandatory information.
  - **Reconciliation Type:** Select any one option from **General Ledger to Product Processor** , **General Ledger to Management Ledger**, **Management Ledger to Product Processor**, **General Ledger to Policy**.
  - **Definition Type:** By default, it is set to **Manual** .
  - **Legal Entity:** Click the **Hierarchy Browser** icon to display the **Hierarchy Browser** window. Select the Legal Entity from the **Available Values** list and move them to the **Selected Values** list. While making a selection, you can use the CTRL key on your keyboard and click the required parent or child entity to make multiple selections. Click **OK**.
  - **Consolidation Type:** Select **Solo** or **Consolidated**. If you select **Consolidated**, only one Parent Legal Entity must be part of the definition.
  - **Inherit to Child:** If you select this toggle button, consolidation type defaults to **Solo** and is disabled.  
For more information on **Inherit to Child**, see the 'Key Terms and Concepts' section.
  - **Balance Type:** Select one of the following options:
    - **End of Period Balance**
    - **End of Period Balance LCY**
    - **Yearly Average**
    - **Monthly Average**

#### Note

For Management Ledger to Product Processor Type, the "End of Period Balance LCY" which is represented as **Balance Year to Date in Local Currency** is now available under Balance Type for reconciliation.

#### Note

The **Yearly Average** and **Monthly Average** balance types are not relevant for Management Ledger reconciliation.

- **Reconciliation Definition:** Select the level at which the balances must be reconciled: **GL Level Recon** or **Map Level Recon**.
- **Adjustment Allocation:** Push this toggle switch on if you want the application to pass an automated adjustment entry for any reconciliation difference found, else leave it at

the default position of off. If left as off, then the reconciliation differences are calculated but adjustment entry will not be passed.

**Note**

The **Reconciliation Definition** and **Adjustment Allocation** options are disabled for **General Ledger to Management Ledger** reconciliation type.

**Note**

If you have created a rule without Allocation and you need to add Allocation, it is recommended you create a new rule instead of editing or copying the existing rule.

2. Click **Next**.

### 19.6.1.3.2 GL Parameters (Source Ledger Parameters)

Provide the following information in the **GL Parameters** tab.

1. Provide the following GL Parameter information:
  - **GL Hierarchy:** Click the Hierarchy Browser icon to launch the **Hierarchy Browser** window.  
Click to select one or multiple (using CTRL key on your keyboard) entities from the **Available Values** list and move them to the **Selected Values** list.  
You can move the available values using the **Move**, **Move All**, **Remove**, **Remove All** buttons, and move items within the **Selected Values** list using the **Move to Top**, **Move Up**, **Move Down**, and **Move to Bottom** buttons. Click **OK** to close the **Hierarchy Browser** window.
  - **Add Filters:** You can Add Filters (for example, product, business unit, and so on) defined in the **Settings** tab. A comparison between the GL system and PPs is based on the filters set on these dimensions.

**Note**

**Financial Element** Average Balance filter must be selected for an average reconciliation in General Ledger to Management Ledger, General Ledger to Product Processor or General Ledger to Policy reconciliation types.

2. Click **Next**.

### 19.6.1.3.3 Target Parameters

These are configuration settings of the target side entities and measures.

**Topics:**

- GL Level Reconciliation (If GL Level is selected in the **Settings** tab)
- Map Level Reconciliation (If Map Level is selected in the **Settings** tab)

### 19.6.1.3.4 GL Level Reconciliation (If GL Level is selected in the Settings Tab)

This section describes settings in the **Target Parameters** tab if the **GL Level** option is selected in the **Settings** tab.

1. Select the following details:

#### Target Entity

- **Target Entity Name:** Select the name of the entity that contains the data from the drop-down list.
- **GL Reconciliation Column:** Select the reconciliation column from the drop-down list. The selected column name appears as a card with **Target Parameters**, **Filters**, and **Delete** icons.
- **Threshold Currency:** Select the Threshold Amount of currency from the drop-down list.

2. On a selected **GL Reconciliation Column** card, click the **Target Parameters** icon.

3. Provide the following **Target Parameter** details:

#### Target Parameters

- **Threshold Specification:** Select **Percentage** or **Absolute** from the drop-down list. If you select **Percentage**, the **Threshold Currency** field is disabled.

The threshold value can be in either absolute or percentage at a PP level. However, if the selection in all the PPs is percentage, the **Threshold Currency** field is disabled.

- **Negative Threshold:** Specify the negative threshold value. These values are used to identify the breach types, categorized as:
  - Negative Percentage Threshold (NPT)
  - Positive Percentage Threshold (PPT)
  - Negative Absolute Threshold (NAT)
  - Positive Absolute Threshold (PAT)
  - Not Breached (NB)

The breach type is identified at run time during the reconciliation process and audit trail entries are posted with this information. For GL Level reconciliation, values can be updated at different PP levels. For Map Level reconciliation, you have to manually enter only one value for all the PPs.

- **Adjustment Entry Floor:** Specify the value required to pass an adjustment entry. If the (GL-PP) difference is less than the Adjustment Entry Floor value specified here, the calculated difference is not eligible for the adjustment, and the entry is not logged in the Adjustment Entry table.
- **Positive Threshold:** Specify the Positive Threshold value. These values are used to identify the breach types, categorized as:
  - Negative Percentage Threshold (NPT)
  - Positive Percentage Threshold (PPT)
  - Negative Absolute Threshold (NAT)
  - Positive Absolute Threshold (PAT)
  - Not Breached (NB)

The breach type is identified at run time during the reconciliation process and audit trail entries are posted with this information. For GL Level reconciliation, values can be updated at different PP levels.

**Filter:** Select the currency to specify the **Threshold Amount**. Additionally, click the Filter pane to add more details to the additional dimensions selected.

You can also add filters to the optional dimensions (product, business unit, and so on) defined in the Settings tab. A comparison between the GL source system and PPs is based on the filters set on these dimensions. See the following steps to add filters:

- a. Click the Filters from the drop-down list.
  - b. Select the relevant dimension from the Filters pane.
  - c. Click the selected dimension, which enables a second drop-down list to select the relevant members for the dimension under consideration.
4. Click **Next**.

### 19.6.1.3.5 Map Level Reconciliation (If Map Level is selected in the Settings Tab)

This section describes settings in the **Target Parameters** tab if the **Map Level** option is selected in the **Settings** tab.

In this window, the **GL Reconciliation** column is disabled when Map Level Reconciliation is selected, click **Add** to update the PP entity or Target entity details.

For more information to update the Target entity details, see the GL Level Reconciliation (If GL Level is selected in the Settings tab) section.

### 19.6.1.3.6 Dimensions

This section describes settings in the **Dimensions** tab, which displays the mandatory dimensions: **Legal Entity**, **Currency**, and **Accounting Standard**. Optionally, from the **Reconciliation Dimension** list, you can select the dimension you want to add to the map definition, and click **Save**.

Note that **Legal Entity**, **Currency**, and **Accounting Standard** are mandatory dimensions. These dimensions, which are defined in the **Settings** tab, appear in the **Dimensions** tab also, indicating that a comparison between the GL system and the PP system and any reconciliation difference is populated based on these dimensions. Reconciliation Dimensions are optional dimensions that are also populated in this window as defined in **Type** configuration.

Click **Next**.

### 19.6.1.3.7 Allocation

The **Allocation** tab is not applicable for **General Ledger to Management Ledger**.

Configure the following **Allocation** settings:

- **Adjustment Allocation:** Select **Automatic** if you want the application to pass automated adjustment entries, else select **Manual**.
- **Adjustment Posted to:** Select the target table where the adjustments are to be posted, that is, select **Product Processor** if the adjustment entry must be posted to the Product Processor selected in the **Product Processor Parameter** window, else, select **Other**.
- **Target Entity:** Based on the selections made in the preceding two fields, the **Target Entity** is disabled or enabled. Select the appropriate option.
- **Adjustment Rule:** Select the **Adjustment Rule**.

- **Allocation Amount Column:** Is enabled or disabled based on the **Adjustment Posted To** option selected. Balance Attribute.
- **Allocation Ratio:** If adjustment entry is to be passed to more than one PP entity, specify the ratio at which this entry is to be passed.
- **Adjustment Attributes:** Use this field to split the adjustments further based on the non-dimension columns of the Target table. The reconciliation definition differences that arise from the definition execution can be adjusted back to the target table, based on the values of non-dimension columns. This can be done apart from the dimension columns.

For post adjustments with more granularity, perform the following steps:

1. Click the hierarchy icon under **Adjustment Attributes**.
2. Click inside the box. Search and select the attributes from the list.
3. Click **Done**.
4. Click **Save**.

Do not select these attribute types from the **Adjustment Attributes** list:

- Reconciliation Dimensions
- Number Data Type Columns
- Date Data Type Columns

#### **Note**

Reconciliation differences are created based on reconciliation dimensions alone but not on the Adjustment Attributes selected.

Adjustment Attributes play a role in creating adjustments with the differences that are observed. The values in the selected Adjustment Attributes of the participating columns of aggregation are read and based on the unique combination of values in these attribute columns, adjustments are created and the same values default in the respective adjustments. The reconciliation definition differences are split among the adjustments based on the weighted average ratio of the participating target balance values.

For more information about Adjustment Attributes and an example, see 'Adjustment Attributes'.

#### **Topics:**

- Map Level Reconciliation (if Map Level Reconciliation is selected in the Settings tab)
- GL Level Reconciliation (if GL Level Reconciliation is selected in the Settings tab)

### 19.6.1.3.8 GL Level Reconciliation (if GL Level Reconciliation is selected in the Settings window)

These **Allocation** settings are applicable only if you have selected **GL Level Recon** as the **Reconciliation Definition** the **Settings** tab.

In the **Allocation** screen, configure the following settings:

- **Adjustment Allocation:** If you have selected **Reconciliation Definition** as **GL Level Recon**, this is considered as **Automatic** by default.
- **Adjustment Posted to:** Select the target table where the adjustments are to be posted, that is, if the adjustment entry is to be posted to PP selected in the Product Processor Parameter window, select **Product Processor**, else select **Other**.

- **Target Entity Details:** Based on the selections made in the preceding two fields, the **Target Entity** is disabled or enabled. Select the appropriate option. See the following cases for more information:

**Table 19-5 Target Entity Settings**

If Adjustment Posted to (target table) is...	...configure these settings
<b>Product Processor</b>	<b>Default Values</b> is the only column that is updated. This is the mandatory column to be updated for populating the Target Entity results.
<b>Other</b>	<b>Target Entity, Default Values, Allocation GL Column, and Allocation Ratio</b> are updated. If the adjustment entry is to be passed to more than one Product Processor entity, the ratio at which the entry is passed is updated in the <b>Allocation Ratio</b> field.

### 19.6.1.3.9 Map Level Reconciliation (if Map Level Reconciliation is selected in the Setting pane)

These **Allocation** settings are applicable only if you have selected **Map Level Recon** as the **Reconciliation Definition** in the **Settings** tab.

In the **Allocation** screen, configure the following settings:

- **Adjustment Allocation:** If you want the service to pass automated adjustment entries, select **Automatic**, else select **Manual**.
- **Adjustment Posted to:** Select the target table where the adjustments are to be posted, that is, if the adjustment entry is to be posted to PP selected in the Product Processor Parameter window, select **Product Processor**, else select **Other**.
- **Target Entity:** Based on the selections made in the preceding two fields, **Target Entity** is disabled or enabled. Select the appropriate option. See the following cases for more information:

**Table 19-6 Target Entity Settings**

If the Adjustment Allocation is...	and Adjustment Posted to (the target table) is...	configure these columns
<b>Automatic</b>	<b>Product Processor</b>	Update <b>Default Values</b> only. This is the mandatory to update for populating the Target Entity results.
<b>Manual</b>	<b>Product Processor</b>	Update <b>Default Values</b> and <b>Allocation Ratio</b> only. If the adjustment entry is to be passed to more than one Product Processor entity, update the ratio at which the entry is to be passed in the <b>Allocation Ratio</b> field.
<b>Automatic</b>	<b>Other</b>	Update the corresponding <b>Target Entity</b> and <b>Default Values</b> .
<b>Manual</b>	<b>Other</b>	Update <b>Target Entity, Default Values, and Allocation Ratio</b> .

### 19.6.1.3.10 Adjustment Attributes

Here is an example that briefly explains the Adjustment Attributes functionality.

Sample data has dimensions lv code, ccy code, and gaap code. The ownership type attribute is used as an Adjustment Attribute.

v_account_number	v_lv_code	v_ccy_code	v_gaap_code	n_eop_bal	v_ownership_type	v_default_1
Acc01	LE1	USD	USGAAP	4000	IND	A
Acc02	LE1	USD	USGAAP	2000	JOINT	B
Acc03	LE1	USD	USGAAP	3000	JOINT	C

Assuming the source balance is 9300, the following are the differences created as follows.

Source Balance	Target Balance	Difference
9300	9000	300

The following adjustments are posted considering the **ownership type** column into the granularity.

Two unique values, IND and JOINT are used to split the differences and create adjustments.

For Adjustment 1, **ownership type** is IND and the balance is  $(4000/9000)*300$ .

For Adjustment 2, **ownership type** is JOINT and the balance is  $((2000+3000)/9000)*300$ .

v_account_number	v_lv_code	v_ccy_code	_gaap_code	n_eop_bal (diff)	v_ownership_type	v_default_1
GL_01	LE1	USD	USGAAP	133.33	IND	A
GL_02	LE1	USD	USGAAP	166.66	JOINT	A

## 19.6.2 Execution of Rule

After defining the parameters on both the GL and the Product Processor sides, the defined reconciliation rules must be executed, and the differences between the GL data and PP data computed. The Processing Modelling task is used to execute the reconciliation rules. Processing Modelling Framework (PMF) enables a business user, without assistance from a technical analyst, to easily define and execute a run. PMF enables you to define a run by selecting a combination of different GL reconciliation parameters.

### 19.6.2.1 Prerequisite

For more information on defining a Reconciliation Rule, see the 'Reconciliation Rules' section.

For more information on Configured Adjustment template in Reconciliation Rule, see the 'Adjustments section'.

#### Topics:

- Process Modeller
- Process Monitor

#### Note

For Banking and Insurance domains, if there are any changes in the data that is available in the Product Processor tables, it is mandatory to execute **Account Load Run Map Population** and **Policy Load Run Map Population** pipelines respectively.

## 19.6.2.2 Process Modeller

To execute the process run, perform the following steps:

1. On the Oracle Financial Services Accounting Foundation Cloud Home page, click the **Process Orchestration** from the LHS menu.
2. The **Process Modeller** screen appears with a list of available runs. You have options to either execute an available Balance Reconciliation run or create a new run.

When you click on Balance Reconciliation run, the Balance Reconciliation Rule is displayed for execution. On the Process Run Window, the Balance Reconciliation Run is displayed in Pipeline form with Reconciliation Rule and Adjustment Rule. The Pipeline Execution contains four execution level nodes. First is a Start node, second is a Reconciliation node, third is an Adjustment node and fourth is an End node.

### Note

Here, you can run only Reconciliation Rule. The Adjustment template is already configured in Reconciliation Rule.

3. Use the **Search** field to search for available runs. You can also filter the list based on **Process Id**, **Process Name**, and **Application** by choosing the relevant option from the **Sort By** list.
4. Use the UI controls at the bottom of the page to page through the list of available runs.
5. Click the corresponding **More Options** icon for the Balance Reconciliation Run you want to execute and click **Execute Run**. The **Execution** window appears.
6. Select **With Parameters** as the **Execution Type**. Note that you cannot execute the Reconciliation Rule if the **Execution Type** option selected is **Without Parameters**.
7. Enter the following details in the **Execution** window:

**Table 19-7 List of Parameters**

Field	Description
Execution on Threshold Breach	<p>Specify if the execution must run in case the global threshold is breached by selecting one of two options:</p> <p><b>Stop:</b> If you have selected this option, and if the GL reconciliation breaches the global threshold level, the execution task stops.</p> <p><b>Continue:</b> If you have selected this option, and even if the GL reconciliation breaches the global threshold level, the execution continues.</p>

Table 19-7 (Cont.) List of Parameters

Field	Description
Auto Approval	<p>Select one of the following two options:</p> <ul style="list-style-type: none"> <li>• Yes</li> <li>• No</li> </ul> <p>If the Auto Approval flag is set to <b>Yes</b>, the adjustments that are created on top of the Recon output will be posted in the instrument tables.</p> <p>If the Auto approval flag is set to <b>No</b>, then it is termed as a manual adjustment in the system. In this case, it goes to a completely different channel and you can review and publish the adjustments on the Reconciliation Summary UI. If you select the rule and trigger the execution saying auto approval, the adjustments or balances are not posted to the tables directly.</p> <p>If you want review and publish the adjustments or balances and do not want to post all the system generated adjustments into the tables, use the manual adjustment workflow. The manual workflow exports all the adjustments from the execution updating the values for each and every adjustment, importing it and then doing a publish in the in the reconciliation summary UI.</p>
Extraction Date	The date on which the execution is happening.
Run Execution Description	The unique description that you provide for this execution. When this execution is triggered, the execution or the run ASCII that is created will be stamped with the description you provide here. You can tag the execution with this field description. It appears on the Reconciliation Summary UI.
Reconciliation Definition	Select one or multiple reconciliation rules in a single execution of the run. The reconciliation rules are expected to be of only one <b>Reconciliation Type: General Ledger to Product Processor or General Ledger to Management Ledger.</b>
Global Threshold	A <b>Global Threshold</b> is applied over and above the mapping level threshold. If this threshold is breached during the execution, you have the choice to continue or stop the execution process. A Global Threshold is compared with the cumulative percentage difference across all the reconciliation definitions that are executed in a Run. If the adjustments are coming into the system and multiple rules are being executed, you can set for all the rules a global breach of threshold at a certain level, for example 10% or 20%. The typical range for this is from zero to 100.

One is that the individual rule level global special is only at a global level for the entire execution. After executing the run using the **With Parameters** option, rules are displayed in the pipeline with a green tick mark confirming their execution.

**Note**

For a 25D fresh provisioning, in the Out-of-the-Box Reconciliation pipeline, set the following values: Global Threshold Absolute – 0, Global Threshold Currency – select any currency, Global Threshold Option – Percentage, and Threshold Breach Condition – NA. When the Percentage option is selected, the other field entries are ignored and have no impact on the execution.

### 19.6.2.2.1 Use and Execute Custom Reconciliation PMF Process

The Balance Reconciliation framework now supports dual Global threshold validation for identifying reconciliation difference breaches. Users can configure both percentage-based and absolute value-based thresholds, with flexible logic to apply AND/OR conditions. This enhancement improves accuracy in detecting reconciliation difference breaches.

To execute the Custom reconciliation process run, perform the following steps:

1. On the Oracle Financial Services Accounting Foundation Cloud Home page, click the **Process Orchestration** from the LHS menu.

The **Process Modeller** screen appears with a list of available runs.

2. On the Process Modeller page, click **Create** to create a new custom reconciliation process. The Create Process window is displayed.
3. Enter information in the following fields.

**Table 19-8 List of Parameters While Creating a Process**

Field	Description
Process Name	Specify a unique process name.
Process Code	The process code is auto displayed.
Process Description	Enter the process description.
APP Package ID	Select the APP Package ID as 'Reconciliation Framework'.
Process Type	Select 'Run Pipeline' from the drop down list.
ServiceID_Workspace	Select 'Oracle Financial Services Data Service for Analytics' from the drop down list.

4. Click **Create** in the Create Process window and the created process is saved successfully.
5. On the Process Flow page, add the Reconciliation and the Adjustment widgets and click **Save**.
6. In the Search field, use the Custom Reconciliation Process Name that has been created to search for the available runs.
7. Click the corresponding **More Options** icon for the custom Balance Reconciliation Run you want to execute and click **Execute Run**. The **Execution** window appears.
8. Select **With Parameters** as the **Execution Type**. Note that you cannot execute the Reconciliation Rule if the **Execution Type** option selected is **Without Parameters**.
9. Enter the following details in the **Execution** window:

**Table 19-9 List of Parameters**

Field	Description
Execution on Threshold Breach	<p>Specify if the execution must run in case the global threshold is breached by selecting one of two options:</p> <p><b>Stop:</b> If you have selected this option, and if the GL reconciliation breaches the global threshold level, the execution task stops.</p> <p><b>Continue:</b> If you have selected this option, and even if the GL reconciliation breaches the global threshold level, the execution continues.</p>
Auto Approval	<p>Select one of the following two options:</p> <ul style="list-style-type: none"> <li>• Yes</li> <li>• No</li> </ul> <p>If the Auto Approval flag is set to <b>Yes</b>, the adjustments that are created on top of the Recon output will be posted in the instrument tables.</p> <p>If the Auto approval flag is set to <b>No</b>, then it is termed as a manual adjustment in the system. In this case, it goes to a completely different channel and you can review and publish the adjustments on the Reconciliation Summary UI. If you select the rule and trigger the execution saying auto approval, the adjustments or balances are not posted to the tables directly.</p> <p>If you want review and publish the adjustments or balances and do not want to post all the system generated adjustments into the tables, use the manual adjustment workflow. The manual workflow exports all the adjustments from the execution updating the values for each and every adjustment, importing it and then doing a publish in the in the reconciliation summary UI.</p>
Extraction Date	The As of date on which the execution is happening.
Run Execution Description	The unique description that you provide for this execution. When this execution is triggered, the execution or the run ASCII that is created will be stamped with the description you provide here. You can tag the execution with this field description. It appears on the Reconciliation Summary UI.
Reconciliation Definition	Select one or multiple reconciliation rules in a single execution of the run.

Table 19-9 (Cont.) List of Parameters

Field	Description
Global Threshold Percentage	A <b>Global Threshold Percentage</b> is applied over and above the mapping level threshold. If this threshold is breached during the execution, you have the choice to continue or stop the execution process. A Global Threshold Percentage is compared with the cumulative percentage difference across all the reconciliation definitions that are executed in a Run. If the adjustments are coming into the system and multiple rules are being executed, you can set for all the rules a global breach of threshold at a certain level, for example 10% or 20%. The typical range for this is from zero to 100.
Exchange Rate Version	Specify the version of the exchange rate.
Reconciliation Type	Select the appropriate reconciliation type from the drop down list.
Global Threshold Absolute	Enter the global threshold absolute value which is a fixed monetary limit applied across all accounts to flag reconciliation differences that exceed that amount, regardless of percentage.
Global Threshold Currency	Select the appropriate Global Threshold currency from the drop down list. <b>NOTE:</b> Only single selection of currency is allowed.
Global Threshold Option	Select any one of the following options: Percentage: If users select this option, provide <b>Global Threshold Percentage</b> information Absolute: If users select this option, provide <b>Global Threshold Absolute</b> and <b>Global Threshold Currency</b> information. Percentage& Absolute: If users select this option, user must select a <b>Global Threshold Condition (AND/OR)</b> , and provide values for <b>Global Threshold Percentage, Global Threshold Currency, and Global Threshold Absolute</b> . <b>NOTE:</b> If users select Percentage option, provide Global Threshold Percentage information and the Global Threshold Absolute information is not considered and vice versa.
Threshold Breach Condition	This field is only applicable in case of Global Threshold Percentage and Global Threshold Absolute type are selected, else NA must be selected. Select any one of the following options: OR: If either Global Threshold Absolute or Global Threshold Percentage is Breached, then the Final Status will be <i>Breached</i> . AND: If both Global Threshold Absolute and Global Threshold Percentage are Breached, then the Final Status will be <i>Breached</i> . NA: If only Global Threshold Percentage or if only Global Threshold Absolute is selected If both are Not Breached, then the Final Status will be <i>Not Breached</i> .

**Table 19-9 (Cont.) List of Parameters**

Field	Description
Run Purpose	Select the run purpose from the drop down list. This field is optional.

**Note**

10. Click **Execute** to start the run execution.

### 19.6.2.3 Process Monitor

After triggering the execution, you can monitor it live using Process Flow Monitor. To do this, perform the following steps:

1. Click the **Process Orchestration** link on the **Home** page.
2. On the **Process Modeller** screen, click the **Menu** button corresponding to the run you want to view and click **Process Flow Monitor**.
3. The run being executed is displayed with the execution ID. For each execution ID, the following information is displayed:
  - **Entity Name:** The name of the entity.
  - **Process Name: Reconciliation Run** appears as the process name for a GL Reconciliation run.
  - **Process Description: Reconciliation Execution Run** appears as the process description for a GL Reconciliation run.
  - **MIS Date:**
  - **Execution Start Time:**The date and time when the execution run starts.
  - **Last Execution Time:**The date and time of the last execution.
  - **Last updated by:** The name of the user who defined the Run.
  - **Status:** The status of the execution: **Completed**, **Failed**, or **Ongoing**.

You can also view the execution details in the **Execution Log**. For more information on Execution Log, see the 'Execution Log' section of 'Process Orchestration'.

**Note**

You can specify the date in MM/dd/yyyy or MM/dd format in the search box for filtering run executions based on the MISDATE.

### 19.6.3 Reconciliation Summary

The **Reconciliation Summary** page provides a visual representation of the list of completed successfully executions along with their details.

After a batch is executed and the reconciliation differences are identified, based on the type of posting or reconciliation type, whether automatic or manual, the details of the execution are available on the Reconciliation Summary page.

On this page, the execution calendar displays date-wise entries. After a reconciliation batch is successful, an entry is created on the calendar. Click the entry to view the rule definition used and the number of reconciliation differences that have occurred.

To view details of an execution, perform the following steps:

Scrolling further right, you can view the entity to which it was applied, which is, loan contracts; the attributes used, and the adjustment template used for posting the adjustment. This information is what you will see as part of the automatic process. In case of manual, you will find an option here to export the adjustment entries to an Excel sheet. You can then import it, and post it to the PP table.

1. On the AFCS Home page, select a Subledger application and click its **Balance Reconciliation** link. From the LHS menu, click **Reconciliation Summary**. The execution calendar appears with entries corresponding to the date when the executions occurred. Use the + and - buttons to zoom in or zoom out on the calendar respectively. You can also use your mouse scroll to zoom in and out on the calendar to view the entries. After you locate the entry, click it to view details.
2. You can also use the **Execution Date** and **Search Run Description** fields to zero-in on the execution details.
  - **Execution Date:** Click the calendar icon and select the date on which the reconciliation has been executed.
  - **Search Run Description:** This list shows the different runs for the selected execution date. You can select the particular run you are interested in.
3. The description and execution details of the selected run are displayed. You can view the details such as the number of reconciliation differences under **List of Rules**. Click > to view additional details. Under **Execution Details**, you can view the number of rules and the start and end times of the execution.
4. For executions that have been executed with **Auto Approval** flag as **Yes**, the adjustments are directly posted in the target tables. For other executions that are executed with **Auto Approval** flag as **No**, you have the choice to review the adjustments, modify the default values, and then approve the adjustments.

### 19.6.3.1 Exporting Adjustments

The Export option allows you to export the adjustments to an excel sheet and save it.

To export the adjustments, follow these steps:

1. Click Export icon.

The Export Window is displayed.

2. Click Copy.

This action copies the Excel file name.

3. Click Download.

The Save As dialog-box is displayed. Paste the file name. This file name should be same as copied.

### 19.6.3.2 Importing Adjustments

Use the Import option to upload the Microsoft Excel workbook with modified adjustment values.

Partial Adjustments: You have the flexibility to tag one or more adjustments while importing the adjustments into the application. You can enter the keywords **Publish** or **P** in the

**PUBLISH\_STATUS** column of the Microsoft Excel workbook. Only adjustments that are marked for publish will be posted to the Product Processor.

Sometimes, the exported Microsoft Excel sheet has a column called **PUBLISH\_STATUS** with no values initially. You can either enter **Publish** or **P** against the records you want to post to the Product Processor table.

To Import the Microsoft Excel file, follow these steps:

1. On the AFCS **Home** page, click the **My Profile** icon on the top-right corner and click **Administration**. From the LHS menu, click **File Operations**.
2. Click **Upload File**. Enter the following details:
  - Enter the **File Name**.
  - Select the **File Type** as **XLSX File**.
  - Enter the size of file.
3. Click **Generate**.
4. Copy Pre-Authenticated Request URL and execute it using Postman or Swagger as Service Type= PUT.
5. Click **Import** icon. Select the recent file from the pop up after clicking on the upload. It uploads the file back to the server.
6. Click **Approve** icon.  
Only the approved records get published in the target table.
7. Refresh the UI using **Refresh** icon.

### 19.6.3.3 Publishing

You must Approve the adjustment in case to upload the Excel file back to the server or approve the adjustments.

Click **Publish** icon to display the total amount approved by the Authorizer.

The user needs to exercise caution while clicking **Publish** icon. Adjustments once published will be posted in the Target Table.

## 19.7 Configure Adjustments

The Data Adjustment module provides the ability to define templates that can be used for Adjustments. The entities on templates that can be defined refer to the Stage instrument tables of OFS Data Foundation. The templates are used by Balance Reconciliation to define default values for various attributes for the Instrument tables. While posting adjustments, the Data Adjustment module applies the defaults for the adjustments created by Balance Reconciliation.

You must define an Adjustment Template for each Product Processor (PP) involved in the reconciliation process if there are translation differences and adjustments have to be posted.

**Note**

Attributes such as Load Run ID and Account Number must not be used as adjustment attributes during adjustment rule creation. These system-generated identifiers are not intended for rule configuration and should be excluded from rule logic.

If an optional dimension is used in rule creation, the same optional dimension cannot be selected as an adjustment attribute within the corresponding adjustment rule. This restriction ensures consistency and prevents conflicts in rule evaluation.

## 19.7.1 Adjustments Summary

The Adjustments Summary window displays all Adjustment templates defined for various entities. The Adjustment entries associated with the first dimension are displayed. Use the **Search** field to search for an Adjustment entry or filter the entries - alphabetically or based on last modified date. You can also add or delete Adjustments.

## 19.7.2 Search Adjustment Rule

**Prerequisites**

Predefined Adjustment Rule

**Procedure**

To search for an Adjustment Rule, follow these steps:

1. Navigate to the **Adjustment Summary** page.
2. Enter the search criteria in the **Search** field. Among other properties, each Adjustment Entry consists of a **Run Execution ID**, a **GL Date**, and a **Definition**. You may search on any of these properties.

## 19.7.3 Add Adjustment Template

To add an Adjustment template, follow these steps:

1. Navigate to the **Adjustment Summary** page.
2. Click **Add**. The **New** tab appears.
3. Enter the **Name** and **Description** for the Adjustment template.
4. Select the required entity option from the **Entity** list.
5. All attributes associated with the selected entity are displayed. You can specify an expression or default value for each of these attributes. You can also selectively choose attributes whose value you want to define. Use the search icon to search for the attribute you want to define.
6. In the Expression field, specify the default value or the expression for the selected attribute.

For example,

**VARCHAR:** 'NAME'

**NUMBER:** '12345'

**DATE:** to\_date ('12/31/2020','mm/dd/yyyy')

7. Click **Save Expression**.
8. Click **Save**. The Adjustment template you created will appear in the **Summary** page.

## 19.7.4 Update Adjustment Template

To update an existing Adjustment template, follow these steps:

1. Navigate to the **Adjustment Summary** page.
2. Click the Adjustment template link that you want to modify.
3. To reset the expression or default value of an attribute, select the attribute and click **Remove** in the **Expression** field. Now enter the new expression or value and click **Save Expression**.
4. To simply modify an attribute's expression, click the attribute and modify the expression or value in the **Expression** field and click **Save Expression**.
5. Click **Update**.

## 19.8 PMF Dashboard for Balance Reconciliation

You can monitor the process status of a pipeline using the PMF Dashboard. The Balance Reconciliation provides information on the following pipelines:

- General Ledger to Management Ledger
- General Ledger to Product Processor

### Note

In a scenario, where an execution is done with an Auto approval as 'No', the **Adjustment** tile has no events to display where as the **Reconciliation** tile displays the activities of the execution.

### Note

Management Ledger to Product Processor pipeline in the PMF dashboard will be available in the future release .

For more information on the activities, tasks within a pipeline and exporting the results, see [Filtering the PMF Dashboard](#) and [Exporting the PMF Process Activities](#).

## 19.8.1 PMF Dashboard Error Codes and Descriptions for Balance Reconciliation

This section provides information on the list of error codes that are related to Reconciliation Run on the PMF dashboard.

**Table 19-10 Balance Reconciliation Run Error Codes**

Event Name	Event Message	Event Error Code	Event Error Descriptions
Validating GLRECON Parameters	Failed	GLR1001	Exception Occurred while Validating GLRECON Parameters
Fetching Legal Entity Hierarchy	Failed	GLR1002	Exception Occurred while Fetching Legal Entity Hierarchy
Fetching GL Hierarchy	Failed	GLR1003	Exception Occurred while Fetching GL Hierarchy
Generating Source Balance	Failed	GLR1004	Exception Occurred while Generating Source Balance
Generating Target Balance	Failed	GLR1005	Exception Occurred while Generating Target Balance
Reconciliation Differences	Failed	GLR1006	Exception Occurred while Generating Reconciliation Differences
Generating Currency Conversion	Failed	GLR1008	Exception Occurred while Generating Currency Conversion
Checking Threshold Breach	Failed	GLR1009	Exception occurred while assigning Threshold Breach

## 19.9 Hierarchy Configuration for Reconciliation

Hierarchies are used in the User Interface and they allow you to select one or more member nodes or leaf nodes. A Hierarchy browser is a widget that needs data from a cache maintained in internal processing of the entities. A dimension data may change over a period of time, therefore the hierarchy cache must be refreshed to align with the latest dimension data. For this purpose, there is a PMF process available in the AFCS by the name 'Hierarchy Resave'. This process can be executed to refresh the data of hierarchy. Once this step is done, then the Hierarchy Browser widgets start displaying the latest dimension members. The successful execution of PMF process indicates that the dimension data is refreshed in the internal cache. The Hierarchy Resave operation can be done multiple times for a date. It allows you to select more than one dimension hierarchies at once. You must re-save the Hierarchies and then proceed with the Run Pipeline execution.

- User Interface of Reconciliation uses hierarchies as mentioned in the page below. A Rule Configuration page uses Legal Entity and General Ledger hierarchies to render parent-child structures.
- Custom hierarchies are created for Reconciliation and the hierarchy codes are visible in the **Hierarchy Management** tab under **Administration** menu in the AFCS application. You can use this hierarchy code and perform data load activities in the dimension hierarchy entities. The Hierarchy Resave operation is common to the Out-of-the-Box Hierarchies and Custom Hierarchies. You must perform the data load for custom hierarchies in a way which is similar to the Out-of-the-Box hierarchies.

- Legal Entity and General Ledger Hierarchies are parent-child hierarchies for which the hierarchy needs to be loaded in the corresponding hierarchy table of the each of the dimension. The other hierarchies are all single level hierarchies being used in the filters of reconciliation rules.

**Note**

A change in hierarchy data requires the reconciliation rules to be re-configured with the updated hierarchy nodes.

Following are the seeded hierarchies and its corresponding mapping tables:

**Table 19-11 Reconciliation Seeded Hierarchies and their corresponding Mapping Tables**

Hierarchy Codes	Hierarchy Dimensions
HGL001	Product Dimension - Product for Reconciliation
HGL002	Business Unit Dimension - Business Unit for Reconciliation
HGL003	Branch Dimension - Branch for Reconciliation
HGL004	Counterparty Dimension - Counterparty for Reconciliation
HGL005	Currency Dimension - Currency for Reconciliation
HGL006	Organization Unit Dimension - Organization Unit for Reconciliation
HGL008	Legal Entity Hierarchy Dimension - Legal Entity for Reconciliation
HGL009	General Ledger Hierarchy Dimension - GL Code for Reconciliation
HGL012	Accounting Standard Dimension - Accounting Standard for Reconciliation
HGL014	Ledger Dimension - Ledger for Reconciliation
HGL015	Project Dimension - Project for Reconciliation
HGL020	Legal Entity Dimension - Intercompany for Reconciliation
HGL021	Account Dimension - Account for Reconciliation
HGL025	Financial Element Dimension - Financial Element for Reconciliation

To re-save the GL Hierarchies in Process Orchestration, follow these steps:

1. On the **Home** page, select **Process Orchestration** from the LHS menu. The **Process Modeller** page is displayed.
2. Create a pipeline GL Hierarchy Resave and select one or multiple of the above listed Hierarchy names in the Process Orchestration before re-saving them. To create a pipeline, follow these steps:
  - a. On the Process Modeller Page, search for the created pipeline. The Process Flow Page is displayed. This Process Flow is designed on the Drawing Canvas using the Transition, Activity, and Widgets Components available in the floating toolbar. A HIERARCHYRESAVE Widget is added to the START for the purpose of resaving the Hierarchy.



This reconciliation type is defined in the Reconciliation Rule UI. Product Processor is an entity in the AFCS System used to store data that are received from the Operational System of the Bank.

This workflow explains about the execution of a Balance Reconciliation rule for General Ledger to Product Processor.

**Figure 19-2 Balance Reconciliation Workflow**

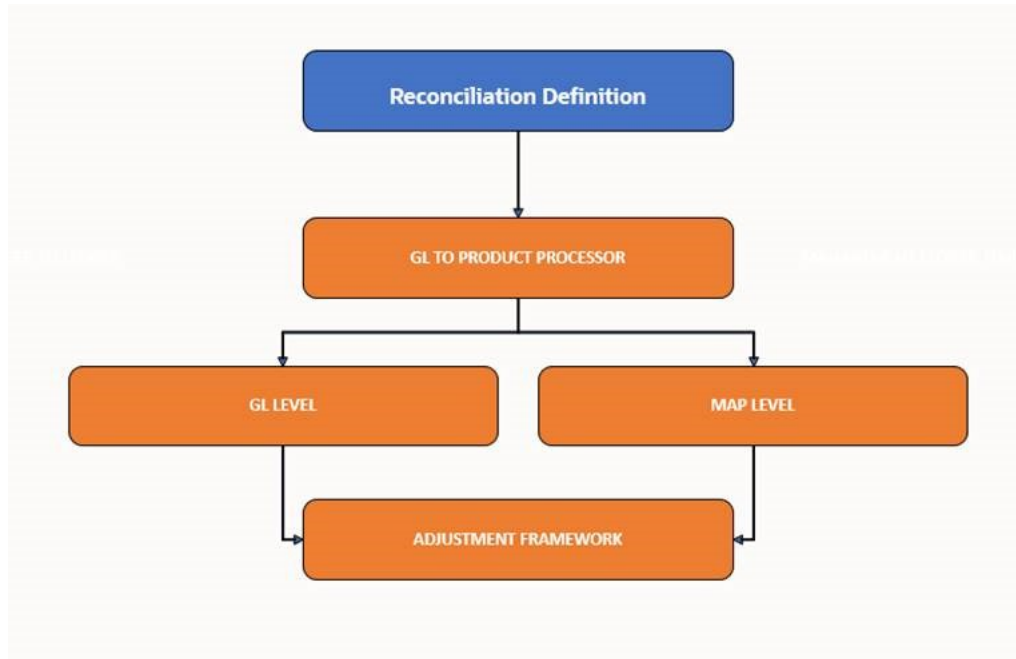

**Figure 19-3 Balance Reconciliation Rule for General Ledger to Product Processor Workflow**

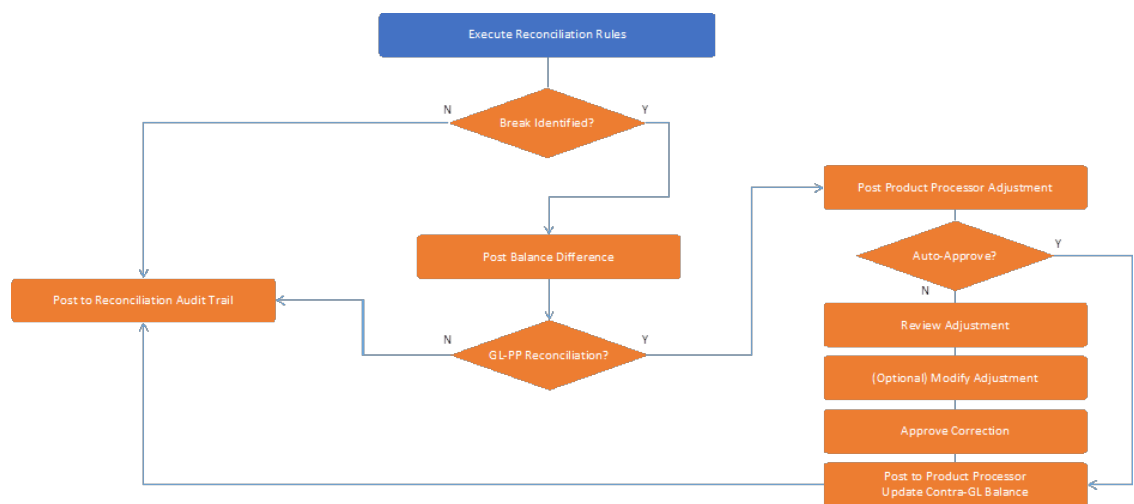

1. First define and consider the Balance Reconciliation Rule.
2. Define the Operational System data, which needs to be used for reconciliation.

3. Configure threshold and Adjustment Entry floor before passing the Adjustments. This is applicable for Manual Reconciliation. For more information on Adjustments, see the Adjustment section. A different allocation ratio can be fixed for passing the adjustment entry into the different Product Processors (PP) that participate in the mapping.
4. Execute the Reconciliation rule using the Process Modelling Framework. When reconciliation differences arise, then the adjustment entries are passed (manually).
  - If there are Reconciliation differences reported after execution, the differences are populated in FACT reconciliation difference table and then these entries are posted as Adjustments. There are two types of reconciliation processes:
    - In Manual Reconciliation process, you can review the adjustments in Reconciliation Summary UI and post the reconciliation entries to product process tables. In manual reconciliation definition, your input is sought on the GL side and PP side to determine the course of reconciliation. This is applicable for both GL Level and Map Level Reconciliation. In GL level reconciliation, unique GL codes are identified from the GL code mapping. At the map level, GL codes do not form a part of the reconciliation definition. A manual reconciliation definition can be used for a Solo or Consolidated Legal Entity. The reconciliation definition for a consolidated GL, having an intra-group GL structure, is computed from GL data and not from PP data. Therefore, any account present in the PP but unavailable in GL is not captured in the reconciliation definition.
    - In Automatic Reconciliation Process, reconciliation entries are posted to the process tables.
  - If there are no Reconciliation differences reported after execution, then no audit entry is made in terms of reconciliation to process table. Further no action is required.

# 20

## Information Access Control

Information Access Control (IAC) provides a flexible and scalable framework for managing user-level access to data within our reporting and analytics systems. IAC enables administrators to define, at both a global and dimension-specific level, which users are permitted to view specific data elements (such as products, legal entities, or custom dimensions), directly supporting fine-grained row-level security.

With IAC, mapping tables define user entitlements for each dimension and dimension member, and enable or disable access centrally. When IAC is enabled for a dimension, users see only the data members they are authorized to view.

Users can enable IAC during provisioning of the application by contacting Oracle Support team. Once IAC is enabled in the application, it is mandatory for users to be mapped to the relevant IAC user group to view the Dimension details under the Balance Computation Results and Results subject area reports.

### Note

Once IAC is enabled in the application, it cannot be disabled or reverted through the application.

## 20.1 Configuring Dimensions for IAC

This section allows you to configure dimensions for creating Data Access Rules in the AFCS application.

To configure dimensions for a data access rule, follow these steps:

1. Login to the AFCS application.
2. On the **Home** page, navigate to **Administration** and select **Information Access Management** tab.
3. From the **Data Access Rules** page, click **Setup** to configure dimensions for data access rules. The Dimension Setup window is displayed.
4. Enter information in the following fields.

**Table 20-1 Dimension Setup**

Fields	Description
Dimension Selection	Select the corresponding dimensions from the drop down list and click <b>Save</b> .

**Table 20-1 (Cont.) Dimension Setup**

Fields	Description
Lock Toggle	After the configuration of dimensions is complete, the setup must be locked with the toggle on the user interface.

**Note**

Once the Lock toggle is enabled, the IAC set up configuration will be locked permanently and cannot be modified.

It is mandatory for users to create data access rules for all the configured dimensions in the AFCS application. Dimensions that must be configured should be available in Balance Computation Results and Results Subject areas.

## 20.2 Managing Data Access Rules

This section allows you to Create, Edit, View and Delete Data Access Rules in the AFCS application.

To create a data access rule, follow these steps:

1. Login to the AFCS application.
2. On the **Home** page, navigate to **Administration** and select **Information Access Management** tab.
3. From the **Data Access Rules** page, click **Create** to create a new data access rule. The Create Access Rule window is displayed.
4. Enter information in the following fields.

**Table 20-2 Data Access Rules**

Fields	Description
Access Rule Name	Enter a unique access rule name.
Description	Enter a description for the access rule.
Dimensions	Click the Selection icon, to select the corresponding dimension member code.

5. Select the **Hierarchy Name** from the drop down list.

**Note**

The Hierarchy Names must be configured and saved through **Hierarchy Management** user interface. Only the saved hierarchy names will be displayed in the drop down list.

6. From the **Hierarchy Browser** page, select the required dimension members from the LHS and the selected dimension members list is displayed on the RHS of the page.

By default, the List View of the dimension members is displayed.

**Search View:** Enter the dimension member and search using this option.

**Sort:** Sort the dimension members using this option.

**Expand:** Expand the dimension members list using this option.

**Select All:** Users can select all the available dimension members using this option.

**Deselect All:** Users can deselect all the selected dimension members using this option.

7. Click **OK** to save the added dimension members to the access rule.

**Note**

It is mandatory to select the Hierarchy member codes for all the configured dimensions displayed in the user interface while creating a data access rule.

8. Click **Save** to save the access rule details and a confirmation message is displayed. The newly added data access rule is displayed in the Data Access Rule Summary page.

Users can also perform the following on the Data access rules:

**View:** Click View to view an existing data access rule details.

**Edit:** Click Edit to edit an existing data access rule.

**Note**

If there is any modification in the existing rule, then the Information Access Control Data Population pipeline must be executed.

**Delete:** Click Delete to delete an existing data access rule.

**Note**

If any existing rule is deleted, the IAC user group must be unmapped from the IAM console and the IAC pipeline must be executed.

## 20.3 Mapping Users to IAC User Groups

Once the access rule has been created, it is necessary to map the User to the corresponding IAC User group to gain the relevant access in the application based on the authorized user. It is mandatory to login to the application with the mapped users atleast once.

To map a user to an IAC user group:

1. Login to the Oracle Cloud Infrastructure console.
2. Navigate to the **Identity and Security** page and select **Domains**.
3. Select the default domain and navigate to **User Management** tab.
4. Search for the User to map to the corresponding IAC User Group.
5. Navigate to **Groups** tab and click **Assign user to group**.
6. Select the corresponding IAC User Group and click **Assign user**. The user is now assigned to the IAC User Group.

In IAM Console, the Description of the User Group refers to the Rule Name in IAC User interface.

## 20.4 Information Access Control PMF Execution

Once the data access rule has been created, the user has been mapped to the IAC User group, logout and login to the application and then execute Information Access Control PMF. Once the PMF has been executed successfully, the Out-of-the-box dimensions are filtered in the Balance computation results and Results subject areas based on the IAC.

To execute the Information Access Control PMF, follow these steps:

1. Login to the AFCS application as a user assigned with IAC User group.
2. On the **Home** page, navigate to the **Process Orchestration** menu and select **Information Access Control Data Population** pipeline from the Process Modeller page.
3. Select the **Execute Run** option from **Actions**.
4. Select the **Execution Type** as **With Parameters** and enter information in the **As of Date** field.
5. Click **Execute**.

# 21

## Issues and Actions

You can resolve any data issue identified in the Cloud framework by creating Issues and appropriate Actions on the **Inbox** page. Data Issues such as Data Quality failures, Variance breaches, or even known issues can be fixed using the **Adjustment Framework** option in **Action**. The adjustment entries posted are audit trailed and data traceability enabled.

### 21.1 Issues

Issues and Actions are Operational Configuration in OFS AFCS.

On the **Inbox** Page, you can log an Issue and create a set of Actions for that Issue. In an Action, you can create a Business Term. For instructions to log or manage an Issue, see the [Manage an Issue](#) section in the [Tracking and Workflow](#) section.

### 21.2 Actions

After logging an Issue, you can create a set of Actions for that Issue on the **Inbox** page. In an Action, you can create a Business Term. For the instructions to log or manage an Action, see the [Manage an Issue](#) section in the [Tracking and Workflow](#) section.

### 21.3 Tracking and Work flow

The **Inbox** page lists all the tasks such as Issues and Actions for a user. You can log Issues, or the Issue can be logged by a Governance Process, or tasks Reassigned from another user. You can create Actions, which are remedial tasks to resolve an Issue. An Action can involve an Adjustment Process to close the Action or Issue. The **Notification** tab lists the latest tasks for the user.

#### 21.3.1 Manage an Issue

This section provides information about how to create, update, close, reopen, or delete an Issue.

##### 21.3.1.1 Create or Log an Issue

To create an Issue, perform the following steps:

1. Navigate to the Inbox by clicking **Inbox** on the Home page.  
The Inbox page is displayed.
2. On the **Inbox** page, click **Log Issue**.  
The **Create Issue** page is displayed.
3. Set the following values.

**Table 21-1 Issues Field Names and Description**

Field Name	Description
<b>Name</b>	Type a unique name.
<b>Description</b>	Type a description.
<b>Category</b>	Select the required Category: <ul style="list-style-type: none"> <li>• <b>Data Authorization</b></li> <li>• <b>Data Privacy</b></li> <li>• <b>Data Security</b></li> <li>• <b>Data Accuracy</b></li> <li>• <b>Data Availability</b></li> <li>• <b>Timeliness</b></li> <li>• <b>Catalog Extension:</b> Use this if you want to extend the out-of-the-box Data Structure.</li> </ul>
<b>Criticality</b>	Set the criticality level for the Issue as: <ul style="list-style-type: none"> <li>• <b>Low</b></li> <li>• <b>Medium</b></li> <li>• <b>High</b></li> </ul>
<b>Target Date</b>	Select the date till when you need this Issue to be active.
<b>Execution Date</b>	Select the date for executing this Issue.
<b>Source</b>	Select a source for the Issue: <ul style="list-style-type: none"> <li>• <b>Controls:</b> Defines the operational and quality controls on every data element and monitors the effectiveness of the control.</li> <li>• <b>Key Indicators:</b> Monitors all the key metrics, trends of the metrics, variances, and so on, for the data elements.</li> <li>• <b>Catalog:</b> To create the Business Term that comprises of elements supporting the business needs of the financial industry.</li> </ul>
<b>Owner</b>	Select the required owner for the Issue.
<b>Comments</b>	Add comments for the Issue, if required.
<b>Attach Documents</b>	Use this to attach documents relevant for this Issue. The file format can be of type: .xls, .pdf, .txt or .doc.

4. Click **Save**.

A confirmation message is displayed.

5. Acknowledge the confirmation message. The new Issue is listed on the **Inbox** page marked with **New** status along with its details.

### 21.3.1.2 Update an Issue

To update an existing Issue, perform the following steps:

1. Navigate to the Inbox by clicking **Inbox** on the **Home** page.

The Inbox page is displayed.

2. On the **Inbox** page, click the required Issue.

The **Issue Details** page is displayed.

3. You can edit the **Description**, **Category**, **Criticality**, **Target Date**, **Owner**, **Comments**, and **Attach Documents** fields.
4. Click **Update**.  
A confirmation message is displayed.
5. Acknowledge the confirmation message.

### 21.3.1.3 Close an Issue

To close an existing Issue, perform the following steps:

1. On the **Inbox** page, click the required Issue.  
The **Issue Details** page is displayed.
2. Click **Close**.  
A confirmation message is displayed.
3. To close the Issue, click **Yes**.
4. Acknowledge the message.  
A confirmation message is displayed.
5. Acknowledge the message.

### 21.3.1.4 Reopen an Issue

To reopen a closed Issue, perform the following steps:

1. On the **Inbox** page, click the closed Issue that you want to reopen.  
The **Issue Details** page is displayed.
2. Click **Re-open**.  
A confirmation message is displayed.
3. To reopen the Issue, click **Yes**.  
A confirmation message is displayed.
4. Acknowledge the confirmation message.

### 21.3.1.5 Delete an Issue

To delete an Issue, perform the following steps:

1. On the **Inbox** page, select the required Issue.
2. Click **Delete**.  
A confirmation message is displayed.

#### **Note**

Ensure that you close all the Actions associated with the Issue and then close the Issue.

3. To delete the Issue, click **Yes**.  
A confirmation message is displayed.

4. Acknowledge the confirmation message.

Alternatively, to re-open, close, delete an Issue, on the **Inbox** page, select the required Issue, click the menu associated with the Issue, and select **Re-open** or **Close** or **Delete** respectively, and follow further instructions as mentioned in the preceding sections.

## 21.3.2 Manage an Action

This section provides information about how to create, update, close, reopen, or delete an Action.

### 21.3.2.1 Create an Action

To create an Action, perform the following steps:

1. Navigate to the Inbox by clicking the **Inbox** button on the **Home** page.  
The **Inbox** page is displayed.
2. On the **Inbox** page, select the required Issue for which you need to create an Action.  
The **Issue Details** page is displayed.
3. On the **Actions** tab, click **Create**.
4. Set the following values.

**Table 21-2 Actions Field Names and Description**

Field Name	Description
<b>Name</b>	Type a unique name for the Action related to the Issue.
<b>Description</b>	Type a description for the Action related to the Issue.

Table 21-2 (Cont.) Actions Field Names and Description

Field Name	Description
<b>Action Type</b>	<p>Select the required <b>Action Type</b>:</p> <ul style="list-style-type: none"> <li>• <b>Data Adjustments - DQ Errors</b></li> <li>• <b>Data Adjustments - Others</b></li> <li>• <b>Data Adjustments - Regulatory Reporting</b></li> <li>• <b>Reconciliation Adjustments</b></li> <li>• <b>Others</b></li> <li>• <b>Catalog Extension</b>: Use this to extend the out-of-the-box Data Structure.</li> <li>• <b>Segments</b>: Use this to extend CoA or ML segments.</li> <li>• <b>Data Entry</b>: Use this to edit data in the custom dimensions using DMI forms.</li> </ul> <div data-bbox="966 693 1466 940" style="border: 1px solid #ccc; padding: 10px; margin-top: 10px;"> <p><b>Note</b></p> <p>If you select the <b>Adjustment</b> based Action Type, then on the <b>Action Details</b> page, <b>Adjustments Tab</b> is displayed, where you can create an Adjustment for the Action.</p> </div> <p>If you select the <b>Catalog Extension</b> Action Type, then on the <b>Action Details</b> page, <b>Extension Tab</b> is displayed, where you can create a Business Term for the Action.</p>
<b>Criticality</b>	<p>Set one of the following criticality levels for the Action:</p> <ul style="list-style-type: none"> <li>• <b>Low</b></li> <li>• <b>Medium</b></li> <li>• <b>High</b></li> </ul>
<b>Start Date</b>	Select the beginning date in the range on which you need this Action to be executed.
<b>Target Date</b>	Select the last date in the range within which you need this Action to be executed.
<b>Owner</b>	Assign the required Owner for the Action.
<b>Comments</b>	Add comments for the Action, if required.
<b>Attach Documents</b>	Use this to attach documents relevant for this Action. The file format can be of type: .xls, .pdf, .txt and .doc

5. Click **Save**.  
A confirmation message is displayed.
6. Acknowledge the confirmation message.
7. Click outside the **Action Details** page to close it. The new Action is listed on the **Inbox** page with the status marked as **New** along with the other Action details.

### 21.3.2.2 Update an Action

To update an existing Action, perform the following steps:

1. On the **Inbox** page, click the required Action.  
The **Action Details** page is displayed.
2. You can edit the **Description**, **Action Type**, **Criticality**, **Start Date**, **Target Date**, **Owner**, **Comments**, and **Attach Documents** fields.
3. To save the changes, click **Update**.  
A confirmation message is displayed.
4. Acknowledge the confirmation message.
5. Click outside the **Action Details** page to close it.

### 21.3.2.3 Approval Work flow for Issues and Actions

This section provides information on the approval work flow for the created issue and the submitted action in AFCS.

#### 21.3.2.3.1 Catalog Extension

The Issue owner has the privilege to view and approve the Actions submitted by the Action owner. Actions once approved cannot be edited further; all the extensions will be disabled for further modifications.

**Figure 21-1 Approval Workflow for Issues and Actions**

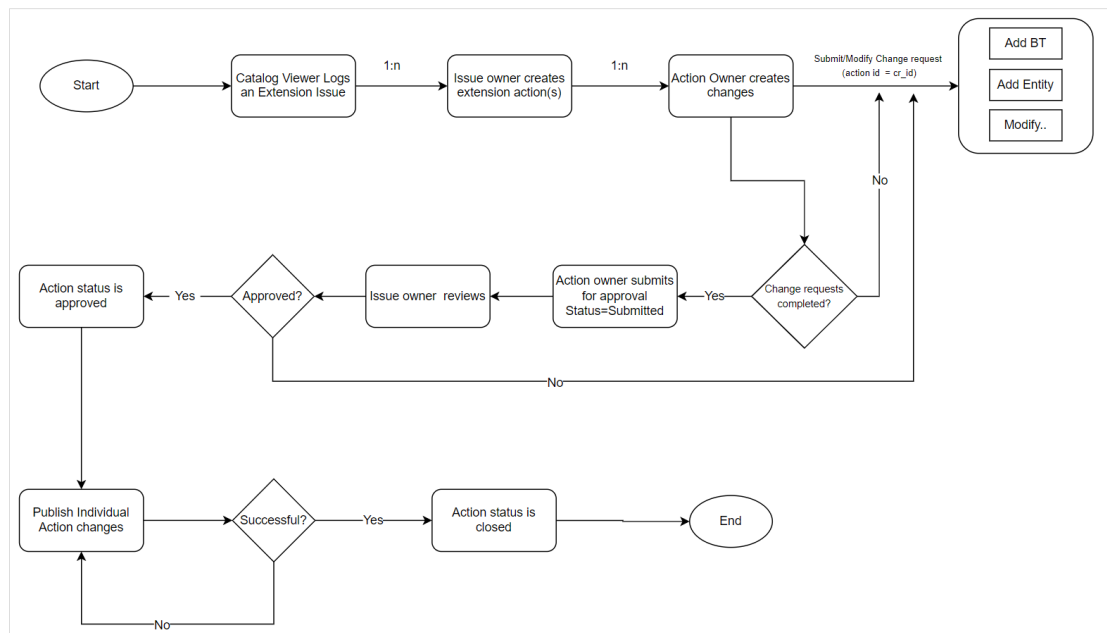

#### 21.3.2.3.1.1 Approve an Action

To approve an existing Action, perform the following steps:

1. On the **Inbox** page, click the required Action whose status is **Submitted**.
2. View the submitted action and the corresponding Business Term details.
3. To approve the Action, click **Approve**.

A confirmation message is displayed.

4. Enter the reason for approving the submitted action, and click **Save**.
5. Close the acknowledgment.

A confirmation message is displayed.

6. Close the acknowledgment.
7. Click outside the **Action Details** page to close it.

#### 21.3.2.3.1.2 Return an Action

To return an existing Action, perform the following steps:

1. On the **Inbox** page, click the required Action.

The **Action Details** page is displayed.

2. You can view the submitted action and the corresponding Business Term details.

3. To return the Action, click **Return**.

A confirmation message is displayed.

4. Enter the reason for rejecting the submitted action, and click **Save**.

A confirmation message is displayed.

#### Note

You can modify Action details and re-submit it for approval.

5. Close the acknowledgment.
6. Click outside the **Action Details** page to close it.

#### 21.3.2.3.1.3 Close an Action

To close an existing Action, perform the following steps:

1. On the **Inbox** page, click the required Action.

The **Action Details** page is displayed.

2. Click **Close**.

A confirmation message is displayed.

3. To close the Action, click **Yes**.

4. Close the acknowledgment.

A confirmation message is displayed.

5. Close the acknowledgment.

6. Click outside the **Action Details** page to close it.

#### 21.3.2.3.1.4 Reopen an Action

To reopen a closed Action, perform the following steps:

1. On the **Inbox** page, click the closed Action that you want to reopen.

The **Action Details** page is displayed.

2. Click **Re-open**.  
A confirmation message is displayed.
3. To reopen the Action, click **Yes**.  
A confirmation message is displayed.
4. Close the acknowledgment.
5. Click outside the **Action Details** page to close it.

#### 21.3.2.3.1.5 Delete an Action

To delete an Action, perform the following steps:

1. On the **Inbox** page, select the required Action.
2. Click **Delete**.  
A confirmation message is displayed.
3. To delete the Action, click **Yes**.  
A confirmation message is displayed.
4. Close the acknowledgment.
5. Click outside the **Action Details** page to close it.

Alternatively, to re-open, close, or delete an Action, on the **Inbox** page, select the required Action, click the menu associated with the Action, and select **Re-open**, **Close**, or **Delete** respectively, and follow instructions mentioned in the preceding sections.

### 21.3.3 Create or Update a Business Term

To create or update a Business Term for an Action, see the Manage Business Terms section in the *OFS AFCS Data Catalog User Guide*.

# 22

## Dashboards and Reports

To access standard dashboards and reports, from the Left Hand Side menu on the Home page of AFCS You will see basic summary reports. On the page header, click the Dashboards menu to view the list of all available seeded dashboards.

- Users with only AFCS-BI groups will be redirected automatically to the Analytics home page post-login.
- Users mapped to both AFCS-BI and AFCS-DV groups will have the option to select between the Dashboard and Data Visualization pages.

Following are the seeded dashboards:

- Balance Computation Engine
- Balance Computation Results
- Data Quality
- Reconciliation Framework Analytics
- Accounting Journals

### Note

During the export, the Data Cell has a configuration limitation of 5 million by default.

### Note

In the AFCS Standard Edition, backward flow is not applicable and therefore Balance Reconciliation is not supported. For more information, see the [About Accounting Foundation Cloud Service- Standard Edition](#).

## 22.1 Overview of Balance Reconciliation Reports and Dashboards

You can generate reports to view the details relevant to computation and other aspects of Balance Reconciliation and Balance Computation.

Balance Reconciliation provides you with a reporting-cum-information framework that you can use to generate reports and view information relevant to computations and other aspects. It is a single regulatory and management reporting solution, and it provides out-of-the-box reporting of your Balance Reconciliation results. You have:

- Tabular and pivot table reporting
- Drill across capability
- Options to export reports to multiple formats such as Microsoft Excel, Microsoft PowerPoint, and PDF

**Note**

In the AFCS Standard Edition, backward flow is not applicable and therefore Balance Reconciliation is not supported. For more information, see the [About Accounting Foundation Cloud Service- Standard Edition](#).

## 22.1.1 Accessing the Standard Reports and Dashboards

The Reconciliation Framework Analytics Dashboard page contain the following tabs:

- Home
- Threshold Breach
- Map Filter Report

**Note**

Reconciliation difference drill down report is deprecated from 23.4.1 version onwards.

Each seeded dashboard has options at the top of the page, which you must select for the reports you wish to see. The **Home** dashboard consist of the following options:

- **As of Date:** Select the **As of date** and click the calendar icon.
- **Execution ID:** All successful Run executions with status marked **Complete** in the **Run Execution Summary** window are populated here. Select the appropriate **Run Execution ID** from the drop-down menu.
- **Legal Entity:** Select the Legal Entity.

Select the options and click **Apply**. To refresh the data, click **Reset**.

The **Threshold Breach** dashboards consist of the following options:

- **As of Date:** Select the **As of date** and click the calendar icon.
- **Execution ID:** All successful Run executions with status marked **Complete** in the **Run Execution Summary** window are populated here. Select the appropriate **Run Execution ID** from the drop-down menu.

The **Map Filter Report** Dashboard consists of the following options:

- **Execution ID:** All successful Run executions with the status marked as **Complete** in the **Run Execution Summary** window are populated here. Select the appropriate **Run Execution ID** from the drop-down list.
- **GL Map ID:** The General Ledger Map identification numbers are populated here. Select the appropriate GL Map ID from the drop-down list.
- **Map Version Number:** The map version numbers are populated here. Select the appropriate Map Version Number from the drop-down list.

A few reports also have filters at each reporting level which are detailed in the section 'Report Descriptions'. Select the appropriate report filters so that data is displayed accordingly. For each report within a dashboard, you can also perform these tasks:

- **Refresh:** Use this to update the values displayed in the report.
- **Print:** Use this to print a particular report.

- **Export:** Use this to export data into multiple formats such as PDF, Microsoft Excel, Microsoft PowerPoint, and so on.
- **Return:** To navigate back to the previous window.
- **Create Bookmark Link:** To share or save a browsed page. Sort icons also appear on each tabular report to sort the data in ascending or descending order. A few reports also consist of a drill-through capability wherein you can navigate to the most granular level of data.

## 22.1.1.1 Report Descriptions

### 22.1.1.1.1 Dashboard: Home

This section provides information about the Dashboard Home page used in the Reconciliation Framework application.

**Table 22-1 Reconciliation Execution Summary information**

Report Name	Reconciliation Execution Summary
Report Level Filters	Not Applicable
Report Description	<p>This report displays the following parameters of the selected Run Execution ID:</p> <ul style="list-style-type: none"> <li>• <b>Map Name:</b> The name of the reconciliation as defined in the <b>Reconciliation Management</b> window.</li> <li>• <b>Map-Version Number:</b> The version number of the defined reconciliation. This indicates the number of times the reconciliation is edited at the reconciliation definition stage.</li> <li>• <b>Legal Entity:</b> The Legal Entity is defined for this particular map and the version number is displayed here.</li> <li>• <b>Consolidation Type:</b> The consolidation types <b>Solo</b>, <b>Consolidation</b>, or <b>Aggregate</b> is displayed here.</li> <li>• <b>Reconciliation Type:</b> The reconciliation types: Ledger to Ledger Reconciliation, General Ledger to Product Processor (Manual Reconciliation), or General Ledger to Product Processor (Auto Reconciliation) are displayed here.</li> <li>• <b>Reconciliation Level:</b> Displays the level at which the reconciliation is performed: <b>GL Level</b> or <b>Map Level</b>.</li> <li>• <b>Adjustment Allocation:</b> Adjustment Allocation is displayed here as <b>Yes</b> or <b>No</b> as defined in the <b>Reconciliation Management</b> window.</li> <li>• <b>Balance Type:</b> The Reconciliation period as defined in the <b>Reconciliation Management</b> window is displayed here.</li> <li>• <b>Reconciliation Dimensions:</b> The Mandatory Dimensions and Optional Reconciliation Dimensions (if any) are displayed here.</li> </ul>
Drill-through On	Not Applicable

**Table 22-2 Reconciliation Difference Report information**

Report Name	Reconciliation Difference Report
Report Level Filters	<p><b>Map Name:</b> The name of the reconciliation as defined in the <b>Reconciliation Management</b> window.</p> <p><b>Map Version:</b> The version number of the defined reconciliation. It indicates the number of times the reconciliation is edited at the reconciliation definition stage.</p>

Table 22-2 (Cont.) Reconciliation Difference Report information

Report Name	Reconciliation Difference Report
Report Description	<p>This report displays the identified Reconciliation Differences for a particular Map. The following parameters are displayed:</p> <ul style="list-style-type: none"> <li>• <b>GL Name:</b> The name of the specific GL entity code of the selected Map name.</li> <li>• <b>Currency:</b> The currency in which the actual reconciliation difference.</li> <li>• <b>Source Balance:</b> The account balance at the source GL entity level. <ul style="list-style-type: none"> <li>– <b>Target Balance:</b> The account balance at the target GL entity level (for Ledger to Ledger reconciliation) or Product Processor.</li> <li>– <b>Positive Reconciliation Difference:</b> Any positive reconciliation difference based on the source entity balance.</li> <li>– <b>Negative Reconciliation Difference:</b> Any negative reconciliation difference based on the target entity balance.</li> </ul> </li> </ul>

**Note**

If the percentage is selected in the **Reconciliation Difference Value Display** field, the positive reconciliation difference and negative reconciliation difference are compared, and the relevant percentage value is populated. For example: If the Actual Positive Reconciliation Difference is 5000 and the Actual Negative Reconciliation Difference is 0, then the percentage is displayed as 100 for positive reconciliation difference.

**Absolute Reconciliation Difference:** This is calculated as the total difference by ignoring the signs between the negative and positive reconciliation differences.

For example: if Positive Reconciliation Difference is 19,500 and the Negative Reconciliation Difference is 23,000, then the absolute difference is 42,500.

**Net Reconciliation Difference:** The net difference between negative and positive reconciliation

**Table 22-2 (Cont.) Reconciliation Difference Report information**

Report Name	Reconciliation Difference Report
	differences. For example: if Positive Reconciliation Difference is 19,500 and the Negative Reconciliation Difference is 23,000, then the net difference is 3,500.
	<b>Percentage Difference:</b> The percentage difference between Source Balance and Target Balance attributes. The value is derived by using the formula $((\text{Source Balance} - \text{Target Balance}) * 100) / \text{Source Balance}$ .

**Note**

On the Dashboard Home page, the reconciliation sections such as **Reconciliation Difference Report**, and **Reconciliation Adjustment Report**, the GL related columns **GL Code**, and **GL Account Name** will be blank/MSG for Map level reconciliation.

**Table 22-3 Reconciliation Adjustment Report information**

Report Name	Reconciliation Adjustment Report
Report Level Filters	<ul style="list-style-type: none"> <li data-bbox="922 993 1455 1073">• <b>Map Name:</b> The name of the reconciliation as defined in the <b>Reconciliation Management</b> window.</li> <li data-bbox="922 1083 1455 1192">• <b>Map Version:</b> The version number of the defined reconciliation. It indicates the number of times the reconciliation is edited at the reconciliation definition stage.</li> </ul>

**Table 22-3 (Cont.) Reconciliation Adjustment Report information**

Report Name	Reconciliation Adjustment Report
Report Description	<p>This report is displayed if Adjustment Allocation is selected as <b>Yes</b> while defining reconciliation. This report displays the adjustment amount pass.</p> <p>The following parameters are displayed:</p> <ul style="list-style-type: none"> <li>• <b>GL Account Name:</b> The name of the specific GL entity code of the selected Map Name.</li> <li>• <b>Currency:</b> The currency in which the Adjustment Entry is processed.</li> <li>• <b>Reconciliation Difference:</b> The net reconciliation difference.</li> <li>• <b>Legal Entity:</b> The Legal Entity as defined for this particular map and version number.</li> <li>• <b>Approved Adjustment Amount:</b> The adjustment amount authorized by the approver.</li> <li>• <b>Pending Adjustment Amount:</b> The adjustment amount pending to be submitted from the Adjustment Entry window.</li> <li>• <b>Submitted Adjustment Amount:</b> The adjustment amount submitted from the Adjustment Entry window, however waiting to be approved by the authorizer.</li> <li>• <b>Rejected Adjustment Amount:</b> The adjustment amount rejected by the authorizer from the Adjustment Entry Approval window.</li> </ul>

 **Note**

The **Adjustment Report** displays the entry of Root Node for Map level executions. You can ignore this particular entry.

### 22.1.1.1.2 Dashboard: Threshold Breach

**Table 22-4 Threshold Breach Summary information**

Report Name	Threshold Breach Summary
Report Level Filters	Not Applicable

Table 22-4 (Cont.) Threshold Breach Summary information

Report Name	Threshold Breach Summary
Report Description	<p>This report displays the threshold parameters of the selected <b>Run Execution ID</b>. The following parameters are reported:</p> <p><b>Global Threshold:</b> Indicates the point of reconciliation difference greater than which execution process may either stop or continue at the time of execution. Global Threshold is compared with cumulative percentage difference across all reconciliation definitions getting executed in a Run.</p> <ul style="list-style-type: none"> <li>• <b>Execution on Threshold Breach:</b> Depending on your selection in the <b>Run Execution Parameters</b> window, <b>Continue</b> or <b>Stop</b> is displayed here.</li> <li>• <b>Auto Approval:</b> The value selected in the <b>Run Execution Parameter</b> window: <b>Yes</b> or <b>No</b>.</li> <li>• <b>Global Threshold:</b> Indicates if the Global Threshold Level is breached or not breached.</li> </ul>
Drill-through On	<p>The following parameters are reported:</p> <ul style="list-style-type: none"> <li>• <b>Map Name:</b> The name of the reconciliation as defined in the <b>Reconciliation Management</b> window.</li> <li>• <b>Map-Version Number:</b> The version number of the defined reconciliation. It indicates the number of times the reconciliation is edited at the reconciliation definition stage.</li> <li>• <b>Number of Observations:</b> The number of times the same map and version is executed.</li> <li>• <b>Number of Breaches:</b> The number of breaches reported based on the threshold value specified in the <b>Reconciliation Management</b> window.</li> </ul>
	Map Name

Table 22-4 (Cont.) Threshold Breach Summary information

Report Name	Threshold Breach Summary
Drill-through Description	<p>Report Name: <b>Threshold Breach Detailed Report</b></p> <p><b>Navigation Path:</b> Click <b>Map Name</b> in the <b>Threshold Breach Summary</b> to view the detailed report.</p> <p><b>Map Level Filters:</b> <b>Map Name, Map Version</b></p> <p>This report provides a detailed view of the threshold value breaches; the following parameters are reported:</p> <ul style="list-style-type: none"> <li>• <b>GL Name:</b> The name of the specific GL entity code of the selected Map Name.</li> <li>• <b>Legal Entity:</b> The Legal Entity defined for this particular map and version number.</li> <li>• <b>Currency:</b> The currency in which the actual reconciliation difference is displayed.</li> <li>• <b>Accounting Standard Code:</b> The Accounting Standard code defined in the reconciliation.</li> <li>• <b>Other optional dimensions:</b> Values against respective optional dimensions (if any) are reported here.</li> <li>• <b>Source Balance:</b> The account balance at the source GL entity.</li> <li>• <b>Target Balance:</b> The account balance at the target GL entity (for Ledger to Ledger reconciliation) or Product Processor.</li> <li>• <b>Reconciliation Difference:</b> The net reconciliation difference amount.</li> <li>• <b>Threshold Breach Type:</b> Indicated as a negative or positive breach based on the positive or negative reconciliation differences.</li> <li>• <b>Threshold Value:</b> The value per the breach type.</li> <li>• <b>Threshold Currency:</b> The Threshold currency is displayed if the <b>Threshold value</b> is in <b>Absolute</b> format.</li> <li>• <b>Threshold Breached by:</b> The value or percentage by which the threshold value is breached based on the reconciliation difference.</li> </ul>

Table 22-5 Global Threshold Breach Summary information

Report Name	Global Threshold Breach Summary
Report Level Filters	Not Applicable

Table 22-5 (Cont.) Global Threshold Breach Summary information

Report Name	Global Threshold Breach Summary
Report Description	<p>This report displays the global threshold parameters of the selected Run Execution ID. The following parameters are reported:</p> <ul style="list-style-type: none"> <li>• <b>Global Threshold Percentage:</b> Indicates the point at which the execution process may stop or continue at the time of execution if the reconciliation difference surpasses the defined Global Threshold level. Global Threshold is compared with the cumulative percentage difference across all reconciliation definitions getting executed in a Run.</li> <li>• <b>Difference Percentage:</b> The absolute percentage difference.</li> <li>• <b>Breach Percentage:</b> The percentage by which the Global Threshold is breached based on the reconciliation difference.</li> <li>• <b>Global Threshold Breached Status:</b> It displays the Breached or Not Breached status.</li> <li>• <b>Global Threshold Condition:</b> This field is only applicable in case of Global Threshold Percentage and Global Threshold Absolute type are selected, else NA must be selected. <ul style="list-style-type: none"> <li>– OR: If either Global Threshold Absolute or Global Threshold Percentage is Breached, then the Final Status will be Breached.</li> <li>– AND: If both Global Threshold Absolute and Global Threshold Percentage are Breached, then the Final Status will be Breached.</li> <li>– NA: If only Global Threshold Percentage or if only Global Threshold Absolute is selected</li> <li>– If both are Not Breached, then the Final Status will be Not Breached.</li> </ul> </li> <li>• <b>Global Threshold Option</b> <ul style="list-style-type: none"> <li>– Percentage: This option, provides Global Threshold Percentage information</li> <li>– Absolute: This option, provide Global Threshold Absolute and Global Threshold Currency information.</li> <li>– Percentage&amp; Absolute: This option, user must select a Global Threshold Condition (AND/OR), and provide values for Global Threshold Percentage, Global Threshold Currency, and Global Threshold Absolute.</li> </ul> </li> <li>• <b>Global Threshold Absolute:</b> The global threshold absolute value which is a fixed monetary limit applied across all accounts to flag reconciliation differences that exceed that amount, regardless of percentage.</li> </ul>
Drill-through On	Not Applicable

**Table 22-6 Threshold Definition information**

Report Name	Threshold Definition
Report Level Filters	<p><b>GL Map Name:</b> Select the name of the specific GL entity map name.</p> <p><b>Map Version:</b> The version number of the selected map name. It indicates the number of times the reconciliation is edited at the reconciliation definition stage.</p>
Report Description	<p>This report displays the following parameters:</p> <ul style="list-style-type: none"> <li>• <b>Target Entity:</b> The name of the Product Processor is displayed here in case of a GL to PP reconciliation, or the name of the Target GL entity.</li> <li>• <b>Target Balance Column:</b> The specific column in the Product Processor (for GL-PP reconciliation) or target GL entity (for GL-GL reconciliation) is displayed here.</li> <li>• <b>The threshold In:</b> The type of threshold: <b>Absolute</b> or <b>Percentage</b>.</li> <li>• <b>Threshold Currency:</b> The currency in which the threshold value is defined. It is not displayed when <b>Percentage</b> is selected.</li> <li>• <b>Positive Correction Threshold:</b> The positive correction threshold value defined in the <b>Reconciliation Management</b> window.</li> <li>• <b>Negative Correction Threshold:</b> The negative correction threshold value defined in the <b>Reconciliation Management</b> window.</li> </ul>
Drill-through On	Not Applicable

### 22.1.1.1.3 Dashboard: Map Filter Report

This dashboard displays the map level definition of Source configuration of Reconciliation definition in Balance Reconciliation.

**Table 22-7 Map Filter Report Information**

Report Name	Reconciliation Source Filters
Report Level Filters	Not Applicable
Report Description	<p>This report displays the following parameters of the selected <b>Run Execution ID</b>:</p> <ul style="list-style-type: none"> <li>• <b>GL Map ID:</b> The map identification number of the reconciliation defined in the <b>Reconciliation Management</b> window.</li> <li>• <b>Map-Version Number:</b> The version number of the defined reconciliation. It indicates the number of times the reconciliation is edited at the reconciliation definition stage.</li> <li>• <b>Dimension Table Name:</b> The name of the Dimension table of the reconciliation defined in the <b>Reconciliation Management</b> window.</li> <li>• <b>Filter Values Selected:</b> The list of filter values of the reconciliation.</li> </ul>

**Table 22-7 (Cont.) Map Filter Report Information**

Report Name	Reconciliation Source Filters
Drill-through On	Not Applicable

**Table 22-8 Map Filter Report -Reconciliation Target Filters**

Report Name	Reconciliation Target Filters
Report Level Filters	Not Applicable
Report Description	<p>This report displays the following parameters of the selected <b>Run Execution ID</b>:</p> <ul style="list-style-type: none"> <li>• <b>GL Map ID</b>: The map identification number of the reconciliation defined in the <b>Reconciliation Management</b> window.</li> <li>• <b>Map-Version Number</b>: The version number of the defined reconciliation. It indicates the number of times the reconciliation was edited at the reconciliation definition stage.</li> <li>• <b>Target Table Name</b>: The name of the target table or Product Processor.</li> <li>• <b>Dimension Table Name</b>: The name of the Dimension table of the reconciliation defined in the <b>Reconciliation Management</b> window.</li> <li>• <b>Filter Values Selected</b>: The list of filter values of the reconciliation.</li> </ul>
Drill-through On	Not Applicable

**Table 22-9 Map Filter Report -Reconciliation Dimensions**

Report Name	Reconciliation Dimensions
Report Level Filters	Not Applicable
Report Description	<p>This report displays the following parameters of the selected <b>Run Execution ID</b>:</p> <ul style="list-style-type: none"> <li>• <b>GL Map ID</b>: The map identification number of the reconciliation defined in the <b>Reconciliation Management</b> window.</li> <li>• <b>Map-Version Number</b>: The version number of the defined reconciliation. It indicates the number of times the reconciliation is edited at the reconciliation definition stage.</li> <li>• <b>Dimension Table Name</b>: The name of the Dimension table of the reconciliation defined in the <b>Reconciliation Management</b> window.</li> </ul>
Drill-through On	Not Applicable

## 22.2 Reporting Custom Mapping

AFCS Supports Custom Dimension and Custom Attributes in OOB dimensions in BCR, RECON and Results Subject Area

AFCS also support Custom Hierarchies in OOB dimensions in BCR subject area.

Users can use the Reporting Configuration window to Map the custom dimension and Custom Attributes in OOB dimension. User can use the custom dimension mapping window to map the custom dimension and the custom attribute mapping window to map the custom attributes.

## 22.2.1 Custom Dimensions

AFCS supports total 15 custom dimension in the Balance Computation Results, Balance Reconciliation and Results subject area. Users will be able to add the custom dimension, custom attributes in OOB table and Alternate Hierarchy in the user interface which will enable in the BI Catalog. Users can use the Report configuration window to map the custom dimension and the attribute mapping window to map the custom attributes.

To define a custom dimension, complete the following steps:

1. On the AFCS Home page, click the **My Profile** icon and select **Administration**.
2. Click **Report Configuration**.
3. Select the dimension and click the Add icon.
4. Select the dimension from the dropdown and click **Save**.

The Dimension name is saved and will be displayed in the BI Catalog.

### Note

In the **Report Configuration** window, the mapped and available flag is displayed to show the availability of custom dimensions. Edit, Delete and View link will be disabled for the Available flag.

Using the dimension mapping window, the user can perform the following:

- **Add:** Click on Add icon to add the custom dimension.
- **View:** Click on View icon to view the mapping for custom dimension.
- **Edit:** Click on Edit icon to Add or Delete the custom attribute in the custom dimension in the BI Catalog.
- **Delete:** Click on the Delete icon to delete the custom dimension from the BI Catalog.
- **Refresh Metadata:** Click on Refresh Metadata button to refresh the staging and results reporting metadata objects.

**Note**

Following are the number of custom dimension for subject area supported in the current release.

**Table 22-10 Number of Custom dimensions supported for each subject area**

Subject Area	No of Custom Dimensions	No of Custom Attributes
Balance Computation Results	15	NUMBER – 20, VARCHAR – 60, DATE - 20
Reconciliation	15	NUMBER – 20, VARCHAR – 60, DATE - 20
Results	15	NUMBER – 20, VARCHAR – 60, DATE - 20
Accounts	15	NUMBER – 20, VARCHAR – 60, DATE - 20
Transactions	15	NUMBER – 20, VARCHAR – 60, DATE - 20

**Note**

The following attributes are added by default in each custom dimension.

- CODE
- ID
- LRI
- SKEY
- RECORD START DATE
- RECORD END DATE
- CLOSED FLAG

## Add Custom Attributes in Custom Dimension

Once the custom dimension is mapped, User can map the custom attributes to the mapped custom dimension. To Define the custom attributes in custom dimension, complete the following steps

1. Select the mapped custom dimension and click **Edit** . This will open a new Attribute Mapping tab for the selected dimension.
2. Using the attribute mapping window, the user can perform the following:
  - **Add Custom Attribute:** Select the Attribute and click **Edit**. Select the Attribute Name from the dropdown and click **Save**
  - **Delete Custom Attribute:**Select the attribute and click delete

## 22.2.2 Custom Attributes for OOB Tables

To define a custom attribute in OOB table, complete the following steps:

1. On the AFCS Home page, click the **My Profile** icon and select **Administration**.
2. Click **Report Configuration**.
3. Select the OOB table and click on the Edit icon.
4. Select the attribute and click on the Edit icon in the Attribute mapping window.
5. Select the Attribute name from the drop down list and click **Save**.
6. To delete a custom attribute, select the attribute and click on Delete icon.

### Note

User cannot Edit or Delete the OOTB dimension, it will display NA flag in the Dimension Mapping window. The available and mapped flag for Custom Attributes are displayed in the Attribute Mapping window to show the availability of attributes.

**Note**

Following are the number of custom attributes for subject area for OOB table supported in the current release.

**Table 22-11 Table Name and Number of Custom Attributes supported**

Presentation Entity Name	No of Custom Attributes
ORGANIZATION UNIT	NUMBER – 55, VARCHAR – 110, DATE - 5
GENERAL LEDGER ACCOUNT	NUMBER – 55, VARCHAR – 110, DATE - 5
PRODUCT	NUMBER – 20, VARCHAR - 20, DATE - 5
LEGAL ENTITY	NUMBER – 20, VARCHAR - 20, DATE - 5
PROJECT	NUMBER – 20, VARCHAR - 20, DATE - 5
BRANCH	NUMBER – 20, VARCHAR - 20, DATE - 5
BUSINESS UNIT	NUMBER – 20, VARCHAR - 20, DATE - 5
ACCOUNTING ENTRIES	NUMBER- 30, VARCHAR - 50, DATE - 8 , CUSTOM DIMENSIONS - 15
ACCOUNT SUMMARY	NUMBER- 30, VARCHAR - 50, DATE - 8 , CUSTOM DIMENSIONS - 15
TRANSACTION SUMMARY	NUMBER- 30, VARCHAR - 50, DATE - 8 , CUSTOM DIMENSIONS - 15
ACCOUNT	NUMBER- 10, VARCHAR- 40, DATE - 8
CHANNEL	NUMBER – 20, VARCHAR – 20, DATE - 5
LOCATION	NUMBER – 20, VARCHAR – 20, DATE - 5
LEDGER	NUMBER – 20, VARCHAR – 20, DATE - 5
INSTRUMENT CONTRACT	NUMBER – 20, VARCHAR – 20, DATE - 5
PARTY	NUMBER – 20, VARCHAR – 20, DATE - 5
DATA SOURCE	NUMBER – 20, VARCHAR – 20, DATE - 5
RECONCILIATION DIFFERENCE SUMMARY	CUSTOM DIMENSIONS - 15*
GL ADJUSTMENT ENTRIES SUMMARY	CUSTOM DIMENSIONS - 15*
GL THRESHOLD BREACHES	CUSTOM DIMENSIONS - 15*
INTEGRATION MANAGEMENT LEDGER COA SEGMENTS COMBINATION	CUSTOM DIMENSIONS - 15*

\*The number of custom dimensions supported against all grains.

## 22.2.3 Custom Hierarchies

AFCS supports the definition of hierarchies based on dimension attributes and their use in the reporting layer. Users will be able to specify display names for hierarchies in the user interface which will enable alternate hierarchies in the BI Catalog. This will allow users to define custom reports in the 'Balance Computation', 'Results', and 'Reconciliation' Subject Areas.

To define a name for a hierarchy, complete the following steps:

1. On the AFCS Home page, click the **My Profile** icon and select **Administration**.
2. Click **Hierarchy Management**.

3. Select the hierarchy table from the **Choose Dimension** drop-down for which you want to define a name and click on the hierarchy.

**Note**

When you expand the custom hierarchy, the code and name is displayed.

The **Definition** section is displayed.

4. Enter the name and description for the for the hierarchy and click **Save**.

The hierarchy name is saved and the same will be displayed in the Reports.

**Note**

Following are the number of custom hierarchies for OOB tables supported in Balance Computation subject area.

- Branch Code - 1
- General Ledger Account Code - 5
- Legal Entity Code - 1
- Organization Unit Code - 4
- Product Code - 1
- Acquisition Channel Code - 1
- Business Unit Code - 1
- Intercompany Identifier - 1
- Location Code - 1
- Project Code -1

**Note**

Following are the number of custom hierarchies for OOB tables supported in Results subject area.

- Branch Code - 1
- General Ledger Account Code - 5
- Legal Entity Code - 1
- Organization Unit Code - 4
- Product Code - 1
- Acquisition Channel Code - 1
- Business Unit Code - 1
- Intercompany Identifier - 1
- Location Code - 1
- Project Code -1

**Note**

Following are the number of custom hierarchies for OOB tables supported in Reconciliation subject area.

- Branch Code - 1
- General Ledger Account Code - 5
- Legal Entity Code - 1
- Organization Unit Code - 4
- Product Code - 1
- Business Unit Code - 1
- Intercompany Identifier - 1
- Project Code -1

Login to the application and execute the process **Reporting Parent Child Relation Data Population**. Select **Dimension Hierarchy Entity** (Single/Multiple) and select the **DataSource** value as NA.

**Note**

Prior to viewing the Dashboard reports, you must run the **Reporting Parent Child Relation Data Population** PMF pipeline.

## 22.3 Balance Computation Engine

From 24.2.1 onwards, the Balance Computation Engine Reports are deprecated and Management Ledger reports will not be available in this Dashboard.

## 22.4 Balance Computation Results

This section provides information about generating and viewing the Balance Computation Results reports. This report provides day and period-to-date (month, quarter, and year) movement information in addition to currently available balance/average balance information.

### Note

In the AFCS Standard Edition, backward flow is not applicable and therefore Balance Computation is not supported. For more information, see the [About Accounting Foundation Cloud Service- Standard Edition](#).

### 22.4.1 Accessing the Standard Reports and Dashboards

To access the standard dashboards and reports in AFCS, complete the following steps:

1. On the Home Page, from the click **Dashboards** from the LHS menu. You will see the basic summary reports.
2. On the page header, click **Dashboards** and select the required dashboard.

Each seeded dashboard contains a set of options at the top of the page, which you must select to create the report. The Balance Computation Results dashboard consists of the following reports:

- Period to Date
- Period to Date History
- Ledger Sets

### Note

After the 25B upgrade, in the BCR subject area, the user cannot view the reports if the extended Out-of-the-box dimension code is not available in the INTEGRATION MANAGEMENT LEDGER COA SEGMENTS COMBINATION ENTITY. Therefore, the user must delete and re-add the extended Out-of-the-box dimension in the Report Configuration User Interface to view the code and then generate the report related to INTEGRATION MANAGEMENT LEDGER COA SEGMENTS COMBINATION ENTITY.

### Note

If IAC is enabled, only the configured dimension member codes will be displayed in the Balance Computation Results Report.

## 22.4.2 Report Descriptions

### 22.4.2.1 Dashboard: Period to Date

AFCS will compute the latest execution for the day and period (month, quarter, and year) to date credit and debit movement figures. This section provides information about the Period to Date dashboard used in Balance Computation Results.

- **Effective Date:** Click the calendar icon and select the effective date.
- **Legal Entity Name:** Select the Legal Entity Name.
- **Fiscal Period:** Select the Fiscal Period.
- **Function Currency:** Select the Function Currency.
- **General Ledger Code:** Select the general ledger code.

After updating the options, click **Apply**. To refresh the data in the fields click **Reset**.

A few reports also have filters at each reporting level which are detailed in the **Report Descriptions** section. Select the appropriate report filters so that data is displayed accordingly. Each report within a dashboard contains the following features:

- **Analyze:** To analyze the values displayed in the report.
- **Edit:** To edit the values displayed in the report.
- **Refresh:** To update the values displayed in the report.
- **Export:** To export data into multiple formats such as PDF, Excel, PowerPoint, and so on.

**Table 22-12 Period to Date Report Information**

Report Name	Period to Date
Report Description	<p>This report displays the following parameters of the selected entity:</p> <ul style="list-style-type: none"> <li>• As of Date</li> <li>• Account or Contract Number</li> <li>• Entity Name</li> <li>• Product Code</li> <li>• General Ledger Account Name</li> <li>• Organization Unit Name</li> <li>• Accounting Standard Description</li> <li>• Management Legal Entity Code Combination Identifier</li> <li>• Code Combination Identifier</li> <li>• Functional Currency</li> <li>• Entered Currency</li> <li>• Quarter to Date Accounting Balance in Entered Currency</li> <li>• Quarter to Date Accounting Balance in Functional Currency</li> <li>• Credit Movement Quarter to Date Accounting Balance in Entered Currency</li> <li>• Credit Movement Quarter to Date Accounting Balance in Functional Currency</li> <li>• Debit Movement Quarter to Date Accounting Balance in Entered Currency</li> <li>• Debit Movement Quarter to Date Accounting Balance in Functional Currency</li> <li>• Average Month to Date Accounting Balance in Entered Currency</li> <li>• Average Month to Date Accounting Balance in Functional Currency</li> <li>• Month to Date Accounting Balance in Entered Currency</li> <li>• Month to Date Accounting Balance in Functional Currency</li> <li>• Credit Movement Month to Date in Entered Currency</li> <li>• Credit Movement Month to Date in Functional Currency</li> <li>• Debit Movement Month to Date in Entered Currency</li> <li>• Debit Movement Month to Date in Functional Currency</li> <li>• Average Quarter to Date Accounting Balance in Entered Currency</li> <li>• Average Quarter to Date Accounting Balance in Functional Currency</li> <li>• Debit Movement Year to Date in Entered Currency</li> <li>• Debit Movement Year to Date in Functional Currency</li> <li>• Average Year to Date Accounting Balance in Entered Currency</li> </ul>

**Table 22-12 (Cont.) Period to Date Report Information**

Report Name	Period to Date
	<ul style="list-style-type: none"> <li>• Average Year to Date Accounting Balance in Functional Currency</li> <li>• Year to Date Accounting Balance in Entered Currency</li> <li>• Year to Date Accounting Balance in Functional Currency</li> <li>• Credit Movement Year to Date in Entered Currency</li> <li>• Credit Movement Year to Date in Functional Currency</li> <li>• Month To Date Net Movement In Entered Currency</li> <li>• Month To Date Net Movement In Functional Currency</li> <li>• Quarter To Date Net Movement In Entered Currency</li> <li>• Quarter To Date Net Movement In Functional Currency</li> <li>• Year To Date Net Movement In Entered Currency</li> <li>• Year To Date Net Movement In Functional Currency</li> </ul>

### 22.4.2.2 Dashboard: Period to Date History

AFCS will compute and persist day and period (month, quarter, and year) to date credit and debit movement figures. This section provides information about the Period to Date dashboard used in Balance Computation Results.

- **Effective Date:** Click the calendar icon and select the effective date.
- **As of Date:** Click the calendar icon and select the As of Date.
- **Run Surrogate Key:** Select the Run Surrogate Key.
- **Legal Entity Name:** Select the Legal Entity Name.
- **Fiscal Period:** Select the Fiscal Period.
- **Function Currency:** Select the Function Currency.
- **General Ledger Code:** Select the general ledger code.

After updating the options, click **Apply**. To refresh the data in the fields click **Reset**.

A few reports also have filters at each reporting level which are detailed in the **Report Descriptions** section. Select the appropriate report filters so that data is displayed accordingly. Each report within a dashboard contains the following features:

- **Analyze:** To analyze the values displayed in the report.
- **Edit:** To edit the values displayed in the report.
- **Refresh:** To update the values displayed in the report.
- **Export:** To export data into multiple formats such as PDF, Excel, PowerPoint, and so on.

**Table 22-13 Period to Date History Report Information**

Report Name	Period to Date History
Report Description	<p>This report displays the following parameters of the selected entity:</p> <ul style="list-style-type: none"> <li>• As of Date</li> <li>• Account or Contract Number</li> <li>• Entity Name</li> <li>• Product Code</li> <li>• General Ledger Account Name</li> <li>• Organization Unit Name</li> <li>• Accounting Standard Description</li> <li>• Management Legal Entity Code Combination Identifier</li> <li>• Code Combination Identifier</li> <li>• Functional Currency</li> <li>• Entered Currency</li> <li>• Quarter to Date Accounting Balance in Entered Currency</li> <li>• Quarter to Date Accounting Balance in Functional Currency</li> <li>• Credit Movement Quarter to Date Accounting Balance in Entered Currency</li> <li>• Credit Movement Quarter to Date Accounting Balance in Functional Currency</li> <li>• Debit Movement Quarter to Date Accounting Balance in Entered Currency</li> <li>• Debit Movement Quarter to Date Accounting Balance in Functional Currency</li> <li>• Average Month to Date Accounting Balance in Entered Currency</li> <li>• Average Month to Date Accounting Balance in Functional Currency</li> <li>• Month to Date Accounting Balance in Entered Currency</li> <li>• Month to Date Accounting Balance in Functional Currency</li> <li>• Credit Movement Month to Date in Entered Currency</li> <li>• Credit Movement Month to Date in Functional Currency</li> <li>• Debit Movement Month to Date in Entered Currency</li> <li>• Debit Movement Month to Date in Functional Currency</li> <li>• Average Quarter to Date Accounting Balance in Entered Currency</li> <li>• Average Quarter to Date Accounting Balance in Functional Currency</li> <li>• Debit Movement Year to Date in Entered Currency</li> <li>• Debit Movement Year to Date in Functional Currency</li> <li>• Average Year to Date Accounting Balance in Entered Currency</li> </ul>

**Table 22-13 (Cont.) Period to Date History Report Information**

Report Name	Period to Date History
	<ul style="list-style-type: none"> <li>• Average Year to Date Accounting Balance in Functional Currency</li> <li>• Year to Date Accounting Balance in Entered Currency</li> <li>• Year to Date Accounting Balance in Functional Currency</li> <li>• Credit Movement Year to Date in Entered Currency</li> <li>• Credit Movement Year to Date in Functional Currency</li> <li>• Month To Date Net Movement In Entered Currency</li> <li>• Month To Date Net Movement In Functional Currency</li> <li>• Quarter To Date Net Movement In Entered Currency</li> <li>• Quarter To Date Net Movement In Functional Currency</li> <li>• Year To Date Net Movement In Entered Currency</li> <li>• Year To Date Net Movement In Functional Currency</li> </ul>

### 22.4.2.3 Dashboard: Ledger Sets

The Ledger Set Report allows user to see Management Ledger Period Balances using a ledger set which is mapped to more than one ledger. This section provides information about the Ledger Sets dashboard used in Balance Computation Results.

- **Effective Date:** Click the calendar icon and select the effective date.
- **Ledgerset Name:** Select the name of the Ledgerset.

After updating the options, click **Apply**. To refresh the data in the fields click **Reset**.

A few reports also have filters at each reporting level which are detailed in the **Report Descriptions** section. Select the appropriate report filters so that data is displayed accordingly. Each report within a dashboard contains the following features:

- **Print:** To print the values displayed in the report.
- **Edit:** To edit the values displayed in the report.
- **Refresh:** To update the values displayed in the report.
- **Export:** To export data into multiple formats such as PDF, Excel, PowerPoint, and so on.

**Table 22-14 Ledger Sets Report Information**

Report Name	Ledger Sets
Report Description	<p>This report displays the following parameters of the selected entity:</p> <ul style="list-style-type: none"> <li>• Effective Date</li> <li>• Ledgerset Name</li> <li>• Ledger Name</li> <li>• As of Date</li> <li>• Functional Currency</li> <li>• Entered Currency</li> <li>• Quarter to Date Accounting Balance in Entered Currency</li> <li>• Quarter to Date Accounting Balance in Functional Currency</li> <li>• Credit Movement Quarter to Date Accounting Balance in Entered Currency</li> <li>• Credit Movement Quarter to Date Accounting Balance in Functional Currency</li> <li>• Debit Movement Quarter to Date Accounting Balance in Entered Currency</li> <li>• Debit Movement Quarter to Date Accounting Balance in Functional Currency</li> <li>• Average Month to Date Accounting Balance in Entered Currency</li> <li>• Average Month to Date Accounting Balance in Functional Currency</li> <li>• Month to Date Accounting Balance in Entered Currency</li> <li>• Month to Date Accounting Balance in Functional Currency</li> <li>• Credit Movement Month to Date in Entered Currency</li> <li>• Credit Movement Month to Date in Functional Currency</li> <li>• Debit Movement Month to Date in Entered Currency</li> <li>• Debit Movement Month to Date in Functional Currency</li> <li>• Average Quarter to Date Accounting Balance in Entered Currency</li> <li>• Average Quarter to Date Accounting Balance in Functional Currency</li> <li>• Debit Movement Year to Date in Entered Currency</li> <li>• Debit Movement Year to Date in Functional Currency</li> <li>• Average Year to Date Accounting Balance in Entered Currency</li> <li>• Average Year to Date Accounting Balance in Functional Currency</li> <li>• Year to Date Accounting Balance in Entered Currency</li> <li>• Year to Date Accounting Balance in Functional Currency</li> </ul>

**Table 22-14 (Cont.) Ledger Sets Report Information**

Report Name	Ledger Sets
	<ul style="list-style-type: none"> <li>• Credit Movement Year to Date in Entered Currency</li> <li>• Credit Movement Year to Date in Functional Currency</li> <li>• Month To Date Net Movement In Entered Currency</li> <li>• Month To Date Net Movement In Functional Currency</li> <li>• Quarter To Date Net Movement In Entered Currency</li> <li>• Quarter To Date Net Movement In Functional Currency</li> <li>• Year To Date Net Movement In Entered Currency</li> <li>• Year To Date Net Movement In Functional Currency</li> </ul>

## 22.5 Data Quality Results

This section provides information about generating and viewing the Data Quality Results reports.

### 22.5.1 Accessing the Standard Reports and Dashboards

To access the standard dashboards and reports in AFCS, complete the following steps:

1. On the Home Page, from the click **Dashboards** from the LHS menu. You will see the basic summary reports.
2. On the page header, click **Dashboards** and select the required dashboard.

#### Note

Refresh the Data Quality dashboard to view updated data.

Each seeded dashboard contains a set of options at the top of the page, which you must select to create the report. The Data Quality dashboard consists of the following options:

- **As of Date:** Select the As of date and click the calendar icon.
- **Execution ID:** Select the run execution identifier.
- **DQ Group Name:** Select the group name.
- **DQ Type:** Select the DQ type.

After updating the options, click **Apply**. To refresh the data in the fields click **Reset**.

A few reports also have filters at each reporting level which are detailed in the **Report Descriptions** section. Select the appropriate report filters so that data is displayed accordingly. Each report within a dashboard contains the following features:

- **Refresh:** To update the values displayed in the report.

- **Export:** To export data into multiple formats such as PDF, Excel, PowerPoint, and so on.

## 22.5.2 Report Descriptions

### 22.5.2.1 Data Quality Results

This section provides information about the Data Quality Results dashboard.

**Figure 22-1 Data Quality Results page**

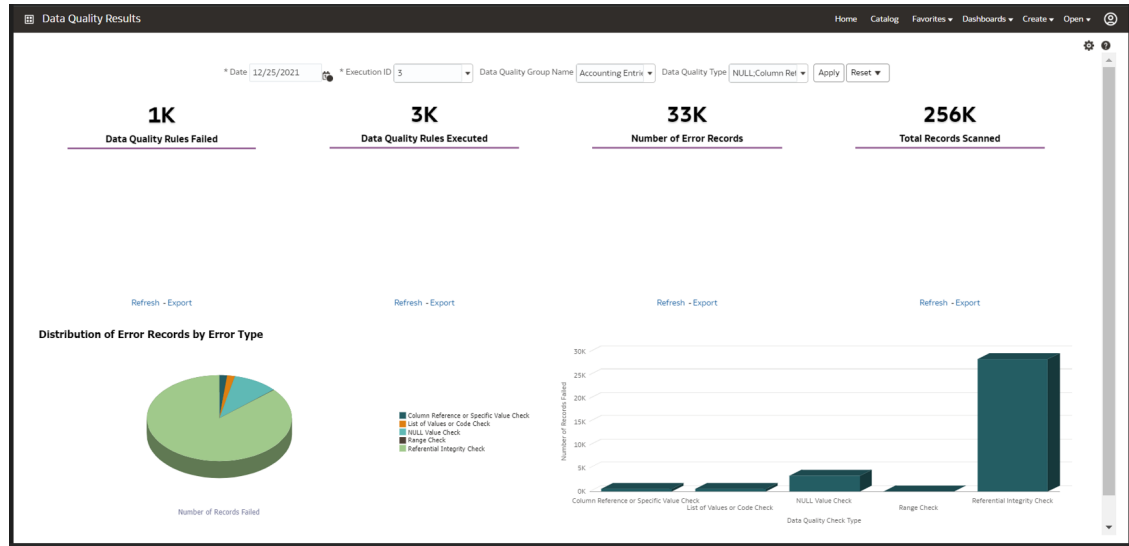

**Table 22-15 Data Quality Results information**

Report Name	Data Quality Results
Report Level Filters	Not Applicable
Report Description	<p>This report displays data quality results along with the distribution of error records by error type.</p> <ul style="list-style-type: none"> <li>• <b>Number of Data Quality Failed:</b> The number of Data Quality records failed is displayed here.</li> <li>• <b>Total Data Quality Executed:</b> The total number of Data Quality checks executed is displayed here.</li> <li>• <b>Number of Error Records:</b> The number of error records in the check is displayed here.</li> <li>• <b>Total Records Scanned:</b> The total number of records scanned is displayed here.</li> </ul>
Drill-through On	Error Records by Error Type

**Table 22-15 (Cont.) Data Quality Results information**

Report Name	Data Quality Results
Drill-through Description	<p>Report Name: Distribution of error records by error type report.</p> <p>Navigation Path: Click the pie chart or bar chart in Data Quality Results to view the detailed report.</p> <p>This tabular report provides a detailed view of the Data Quality check by error type and the following parameters are reported:</p> <ul style="list-style-type: none"> <li>• Entity: The name of the entity.</li> <li>• Attributes: The attribute associated with the Entity.</li> <li>• DQ Check Type Name: Displays the DQ Check type name.</li> <li>• Data Quality Check Code: The Data Quality check code.</li> <li>• Record Scan Count: The record scan count.</li> <li>• Number of Rejected Records: The number of rejected records.</li> <li>• Percentage of Rejected Records Count: The percentage of the rejected records.</li> </ul>

**Table 22-16 Data Quality Error Record Details information**

Report Name	Data Quality Error Record Details Summary
Report Level Filters	Not Applicable

**Table 22-16 (Cont.) Data Quality Error Record Details information**

Report Name	Data Quality Error Record Details Summary
Report Description	<p>Report Name: Distribution of error records by error type report.</p> <p>Navigation Path: Click the Data Quality check code in the Distribution of Error Records by Error Type Report to view the detailed report.</p> <p>This tabular report provides a detailed view of the Data Quality error record details, and the following parameters are reported:</p> <ul style="list-style-type: none"> <li>• Error Record Identifier: Error record identified such as As of Date, Load Identifier and Account Number for DQ Code.</li> <li>• Error Column Value: Error column values for given the DQ.</li> </ul> <div data-bbox="992 751 1463 968" style="border: 1px solid #ccc; border-radius: 10px; padding: 10px; margin-top: 10px;"> <p><b>Note</b></p> <p>In case of duplicate values, the number of occurrences of numeric identifier for any code column will be displayed.</p> </div> <div data-bbox="992 1010 1463 1226" style="border: 1px solid #ccc; border-radius: 10px; padding: 10px; margin-top: 10px;"> <p><b>Note</b></p> <p>In this release, service shall validate the numeric identifiers are unique for a snapshot data load alone for a dimension entity.</p> </div> <div data-bbox="992 1268 1463 1541" style="border: 1px solid #ccc; border-radius: 10px; padding: 10px; margin-top: 10px;"> <p><b>Note</b></p> <p>You can extract the error records using an extract definition <b>Data Quality Error Report</b> as an out-of-the-box extract. For more details, refer to <a href="#">OOTB Extract for Data Quality Error Report</a>.</p> </div>
<p><b>Note</b></p> <p>The check category for Custom DQ rules referencing to dimensions will be shown as "Custom Check" in the Data Quality Result reports.</p>	

**Note**

DQ reports should only be reviewed after the DQ Reporting engine pipeline has been fully executed.

## 22.6 Data Visualization

This section provides information about generating and viewing the Data Visualization reports. Visualizations enable you to dynamically explore datasets in a tabular or a graphical format, all within a single interface. You can visualize data from the staging entities and error tables.

**Note**

- Users with only AFCS-DV groups will be redirected automatically to the Data Visualization home page post-login.
- Users mapped to both AFCS-BI and AFCS-DV groups will have the option to select between the Dashboard and Data Visualization pages.

Accounting Foundation Cloud Service (AFCS) provides data visualization dashboards which are pre-configured to see the raw data from the entities. You can view the data, create new visualization and see the error records. Data Visualization is supported for pre-built datasets and is best suited for scenarios where a query will return a few rows of the output. The following capabilities are present out-of-the box in AFCS:

- View subset of data that is loaded from the source systems.
- Aggregate queries with appropriate filters for use against any dataset.
- Raw data analysis for staging entities are loaded during data ingestion. Grid view to see raw data of the entities post data load.
- Error type identification. Grid view of the error entities in which erroneous records of staging entities are present.
- Query Console to run the SQL query comprising of temporary tables created at run time during data ingestion.
- You can create new datasets or reports in new folders.

**Note**

Filters can display the datasets but refrain from displaying the entire dataset. Custom data elements introduced in the Data Catalog will not be available. Pre-seeded datasets and reports should not be customized.

**Note**

In the AFCS Standard Edition, backward flow is not applicable and therefore any action with respect to Balances, Computation and Revaluation are not supported. For more information, see the [About Accounting Foundation Cloud Service- Standard Edition](#).

## 22.6.1 Access to Data via Data Visualization

Data visualization is an added functionality delivered via analytics, which is provided as part of your AFCS instance.

The following outcomes will be supported via Data Visualization:

1. Access to data in AFCS Catalog - Staging. Refer to Data Catalog User Guide for details.
2. Access to data in Staging - Data movement error datasets. Data movement error datasets contain records of data that have read or load errors, for purposes of verification. See the relevant sections of this document for details on error handling after data movement.

Data visualization enables Business Users to quickly interpret complex data, identify trends and insights, and make informed decisions.

The usage of such tool in production environment is enabling Business Users to get faster, more informed decision-making to drive actionable business outcomes.

Use AFCS Data Extraction feature for this purpose – see [Data Extraction](#) for details.

Data Visualization provided with AFCS is limited to the following navigation paths:

1. Home (Data Sets, Dashboards & Reports)
2. Catalog

### 22.6.1.1 User Roles

Two User roles have been created for data visualization.

- AFCS-DVConsumer- Access Data Visualization Content for Catalog. This role is required for users to view the staging and error table details.
- AFCS-DVContentAuthor- Author Data Visualization Content for Catalog. This role is only required for users who wish to analyze the data ingestion error tables.

## 22.6.2 Accessing the Data Visualization Reports

To access the data visualization reports in AFCS, complete the following steps:

1. On the Home page, click the required SLA and then click **Data Ingestion**.
2. Click **View Data** and then click **Go**.
3. From the LHS menu, click **Catalog**.
4. Under the **Shared Folders** tab, select **Data Visualization Reports** to view the data of the selected error entity or staging entity.

The Data Visualization report consists of the staging table and its corresponding error table details. By default, As of Date is the filter applied for all the staging and error table entries.

#### Note

Always access the reports from the **Dashboard**. Refrain from accessing them through **Shared Folders**.

## 22.6.3 Data Quality for Data Visualization Reports

This section provides information on the Data Quality results for Data Visualization reports.

To access the Data Quality for Data Visualization Reports in AFCS, complete the following steps:

- On the Home page, from the LHS menu, click **Catalog**.
- Under the **Shared Folders** tab, select **Data Quality**, then select **Data Visualization Reports** to view the details of the Data Quality results.

**Figure 22-2 Data Quality Results for Data Visualization Reports page**

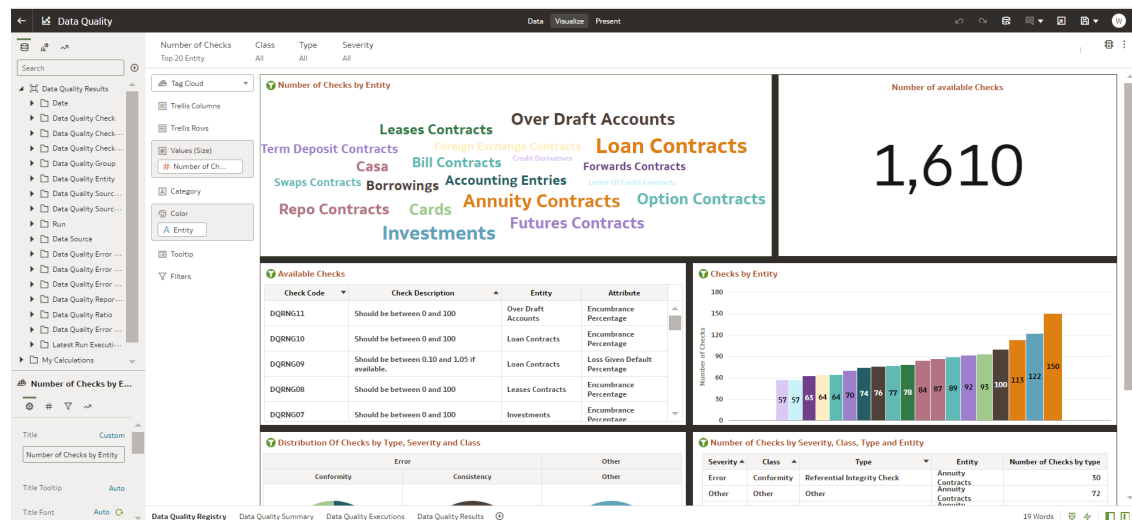

You can navigate among the following canvases in the Data Visualization report:

- Data Quality Registry
- Data Quality Summary
- Data Quality Executions
- Data Quality Results

## 22.6.4 Creating Dataset to View the Custom Attributes in Data Visualization

In order to view the extended custom attributes in a staging table and view their logical names, you can create a Dataset and generate reports in the Data Visualization using OAS interface.

Navigate to **Report Configuration** and click **Refresh Metadata** button before creating a Dataset in the Data Visualization

To create a dataset and view the custom attributes in staging tables in the Data Visualization canvas in AFCS, complete the following steps:

1. On the Home page, click the **Navigator** icon and then click **Data**.  
The Dataset page is displayed.
2. Click Create and select Dataset from the available list.

The Create Dataset window is displayed with the list of available connections.

3. Double click on the **Stage Connection** and the New Dataset page is displayed.

**Table 22-17 Connections and Access Descriptions**

Connections	Access Description
Stage Data Error	User can access Stage Error entities
Processing	User can access Processing entities
Reporting	User can access Reporting entities (Dimension/ Fact/Point of Integration)
Staging	User can access Stage entities

4. From the LHS menu, double click on the **Manual Query**, the Manual Query button is displayed.
5. Double click on the **Manual Query** button, and enter the SQL query under the **Statement** window.
6. Click **Get Preview Data** to preview the data of the entered query.
7. Click **Save** and the **Save Dataset As** window is displayed.
8. Enter the **Name** and **Description** of the dataset and click **OK**.

You can view the list of extended columns in the staging table.

#### Note

Post the migration to OAS 2024, there is an error displayed while opening the existing Datasets in the Data Visualization. To resolve this, follow these steps:

- a. Open the Dataset and click **Edit Definition**.
- b. Click **Get Preview Data** button to preview the data.
- c. Click **OK**.
- d. Click the Save icon to save the dataset.

## 22.6.5 Data Ingestion Query

You can query for the error logging schema using the Data Ingestion Query window. From the PMF pipeline execution log, you can retrieve the query and use it to fetch the final data used by Data Ingestion. The error records which are causing the failure if a connector during the Data Ingestion fails, or if the connector passes the error records are loaded to source error logging entity and target error entity. You can view the error records using the SQL prompt.

**Data Ingestion Query Window** is listed and available as a Data Set in your service instance. This is accessible via Data Sets on the Home portal. It is also accessible via Data - Data Sets navigation path. You can click the **Prepare** option and select the **Edit Definition** button to view the Data Ingestion Query window. Note that you may be taken to the **Visualize** option by default.

In the Results user interface navigate to **Edit Definition** to access the query window.

**Note**

This function should only be used if data ingestion errors are encountered and the logged query requires to be analyzed, as instructed by Oracle Support.

**Note**

When the data ingestion process run is successful, the PMF execution log final select query cannot be used for fetching data. You can use it only in case of a failure.

## 22.6.6 Accessing the Usage Tracking Reports

Usage Tracking is a feature in OBIEE/OAS (Oracle Analytics Server) that enables users to monitor and analyze the system usage. It captures details of reports executed and queries issued to the database, providing visibility into how the analytics environment is being used. This feature is particularly useful for identifying and analyzing reports, dashboards, or queries that may require performance optimization. By reviewing usage data, administrators can detect inefficiencies, tune queries, and improve overall system performance.

To access the usage tracking Reports in AFCS, complete the following steps:

- On the Home page, from the LHS menu, click **Catalog**.
- Under the **Shared Folders** tab, select **Data Visualization Reports**, then select **Usage Tracking** to view the details of the system usage.

**Figure 22-3 Usage Tracking in OBIEE**

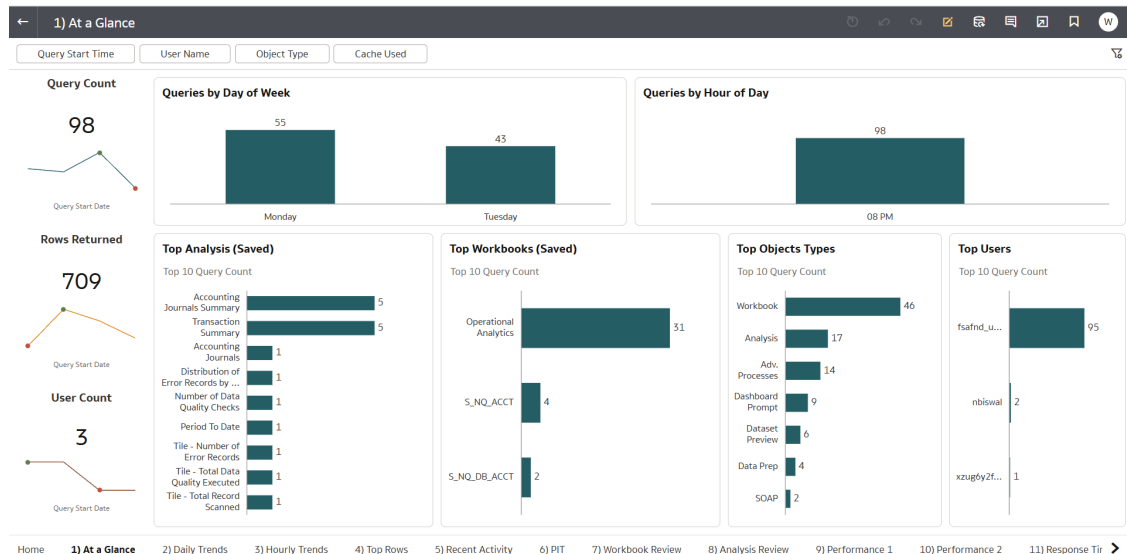

You can navigate among the following canvases in the Usage Tracking report:

- At a Glance - Ability to view common metrics by several data filters
- Daily Trends - Allows a user to view standard usage metrics by day
- Hourly Trends - Allows a user to view standard usage metrics by hour

- Recent Activity - Allows a user to view standard usage metrics by hour
- Top Rows - Shows the objects returning the most rows
- PIT - Allows a user to quickly see what's happening for a specific Point in Time (Day /Hour)
- Workbook Review - Review basic usage stats for (DV) workbooks
- Analysis Review - Review basic usage stats for (Classic) dashboards and analysis
- Performance 1 - Designed to help understand dashboard response time over selected periods to locate long running analysis'
- Performance 2 - Designed to help understand dashboard response time over selected periods (Box Plot)
- Response Times - A treemap displaying average response times across selected periods for dashboards
- Rows vs Response - Shows a scatterplot weighing returned rows and average response times for a dashboard
- Query Review - View the logical and physical SQL generated by the system
- User Review - Displays an overview of a user's activities
- User Review Adv. - Provide additional visuals and metrics for a user Errors - Centralized canvas to review and monitor errors generated by users

## 22.7 Business Intelligence Publisher

Business Intelligence Publisher is the reporting solution to author, manage, and deliver all your reports and documents easier and faster than traditional reporting tools.

### Note

In the AFCS Standard Edition, backward flow is not applicable and therefore Balance Computation and Balance Reconciliation are not supported. For more information, see the [About Accounting Foundation Cloud Service- Standard Edition](#).

### 22.7.1 Access to Business Intelligence Publisher

Business Intelligence Publisher (BIP) is an added functionality delivered via analytics, which is provided as part of your AFCS instance. You can create Reports, Data Model, Report templates, and Schedule reports.

1. From the Home page, click **Dashboards** from the LHS menu. The BI Analytics page is displayed.
2. Copy and paste the analytics URL in a browser and modify the term **analytics** to **xmipserver** in the URL. This navigates to the Business Intelligence Publisher page.

### Note

Remove the term `saw.dll?bieehome` from the analytics URL while copying and pasting it in a browser.

## 22.7.2 Creating Data Model to Generate BIP Report

This section provides step-by-step procedure on creating data models using SQL query to generate a Business Intelligence Publisher report.

1. Login into the Oracle BIP URL using the corresponding credentials.
2. On the **Home** page, navigate to the **New** menu. Select the **Data Model** option from the drop down list.
3. On the **Data Model** page, under the **Diagram** tab, click the **Add** icon to add a new Data Set.
4. Select any one of the following options to create a Data model.

### Option 1

- a. Select **SQL Query** option from the drop down list. The New Data Set- SQL Query window is displayed.
- b. Enter the Data Set Name, Data Source, Type of SQL and the SQL Query and click **OK**. The list of available columns are displayed.

#### Note

The Data Source field will have the value **REP\_CONN** by default.

### Option 2

- a. Select **Analysis** option from the drop down list. The New Data Set- Analysis window is displayed.
- b. Enter the Data Set Name, Time Out (in seconds) and select the required Analysis using the **Search** icon, and click **OK**. The list of available columns are displayed.

### Option 3

- a. Select **DV Data** option from the drop down list. The New Data Set- DV Data window is displayed.
  - b. Select the appropriate DV Data from the available list and click **Next**. The list of available columns for the corresponding DV Data are displayed.
  - c. Select all the required DV Data columns and click **Next**.
  - d. Click the **Add** icon to add the parameters and click **Finish**.
5. On the **Data Model** page, select **Data** tab to view the Data Set details.  
Users can view the Data Set in either **Tree View** or **Table View**.
  6. Under **Data** tab, select the **Save As Sample Data** and click **OK**.
  7. On the **Data Model** page, click **Save** icon to save the Data Model details.

For more information on retrieving the BI Publisher report, see the *Retrieving BI Publisher Export File from Object Storage* section in the [API Guide](#).

## 22.8 Accounting Entries Report

This dashboard will show the journal data information for 'Accounting Journals', 'Revaluation Entries' and 'Revaluation Execution'.

**Note**

In the AFCS Standard Edition, backward flow is not applicable and therefore Balance Computation and Balance Reconciliation are not supported. For more information, see the [About Accounting Foundation Cloud Service- Standard Edition](#).

## 22.8.1 Accessing the Standard Reports and Dashboards

To access the standard dashboards and reports in AFCS, complete the following steps:

1. On the Home Page, from the click **Dashboards** from the LHS menu. You will see the basic summary reports.
2. On the page header, click **Dashboards** and select the required dashboard.

Accounting Entries consists of two dashboards:

- Accounting Journals
- Revaluation Entries
- Revaluation Execution

## 22.8.2 Report Descriptions

### 22.8.2.1 Accounting Journals

This section provides information about the journal data information for 'Accounting Journals' used in Results Subject Area.

Accounting Journals report has the following filters:

- **As of Date:** Click the calendar icon and select the As of date.
- **Account Or Contract Number:** Select the account or contract number.
- **Ledger Name:** Select the ledger name.
- **General Ledger Account Code:** Select the general ledger account code.
- **Account Currency Code:** Select the currency code.
- **Data Source Code:** Select the data source code.
- **Source Journals:** Select the source journals.

Based on the Event Identifier value, the Source Journal values in the Accounting Journals results Subject area are displayed as follows: If the Event identifier value is "0" or "Null", then the source journal value is displayed as "Yes" else it is displayed as "NO" in the drop down list.

After updating the options, click **Apply**. To refresh the data in the fields click **Reset**.

A few reports also have filters at each reporting level which are detailed in the **Report Descriptions** section. Select the appropriate report filters so that data is displayed accordingly. Each report within a dashboard contains the following features:

- **Analyze:** To analyze the values displayed in the report.
- **Refresh:** To update the values displayed in the report.
- **Edit:** To edit the values displayed in the report.

- **Export:** To export data into multiple formats such as PDF, Excel, PowerPoint, and so on.

**Note**

If IAC is enabled, only the configured dimension member codes will be displayed in the Accounting Journals Report.

**Table 22-18 Accounting Journals Report Information**

Report Name	Accounting Journals
Report Description	<p>This report displays the following parameters of the selected entity:</p> <ul style="list-style-type: none"> <li>• Run Identifier: The Run Identifier is displayed here.</li> <li>• As of Date: The As of Date is displayed here.</li> <li>• Account Or Contract Number: The Account Or Contract Number is displayed here.</li> <li>• Ledger Numeric Identifier: The Ledger Identifier is displayed here.</li> <li>• Accounting Standard Code: The Accounting Standard Code is displayed here.</li> <li>• Business Unit Code: The Business Unit Code is displayed here.</li> <li>• Channel Code: The Channel Code is displayed here.</li> <li>• Branch Code: The Branch Code is displayed here.</li> <li>• Product Code: The Product Code is displayed here.</li> <li>• Organization Unit Code: The Organization Unit Code is displayed here.</li> <li>• Debit Credit Indicator: The Debit Credit Indicator is displayed here.</li> <li>• Ledger Name: The Ledger Name is displayed here.</li> <li>• Party Identifier: The Party Identifier is displayed here.</li> <li>• Data Source Code: The Data Source Code is displayed here.</li> <li>• Legal Entity Code: The Legal Entity Code is displayed here.</li> <li>• Transaction Code: The Transaction Code is displayed here.</li> <li>• Event Identifier: The Event Identifier is displayed here.</li> <li>• Transaction Mnemonic Code: The Transaction Mnemonic Code is displayed here.</li> <li>• Transaction Posting Date: The Transaction Posting Date is displayed here.</li> <li>• Account Currency Code: The Account Currency Code is displayed here.</li> <li>• Account Currency Amount: The Account Currency Amount is displayed here.</li> <li>• Local Currency Code: The Local Currency Code is displayed here.</li> <li>• .Local Currency Amount: The Local Currency Amount is displayed here.</li> <li>• Transaction Reference Number: The Transaction Reference Number is displayed here.</li> <li>• Value Date: The Value Date is displayed here.</li> <li>• Transaction Date: The Transaction Date is displayed here.</li> </ul>

**Table 22-18 (Cont.) Accounting Journals Report Information**

Report Name	Accounting Journals
	<ul style="list-style-type: none"> <li>• Transaction Description: The Transaction Description is displayed here.</li> <li>• Conversion Type: The Conversion Type of currency is displayed here.</li> <li>• Authorizer Name: The Authorizer Name is displayed here.</li> <li>• Creator Name: The Creator Name is displayed here.</li> </ul>

## 22.8.2.2 Revaluation Entries

AFCS revaluations provide a journal displaying the balance movements for each revaluation in the Revaluation Entries report.

Revaluation Entries report has the following filters:

- **As of Date:** Click the calendar icon and select the As of date.
- **Ledger Name:** Select the ledger name.
- **Account Currency Code:** Select the currency code.

After updating the options, click **Apply**. To refresh the data in the fields click **Reset**.

A few reports also have filters at each reporting level which are detailed in the **Report Descriptions** section. Select the appropriate report filters so that data is displayed accordingly. Each report within a dashboard contains the following features:

- **Analyze:** To analyze the values displayed in the report.
- **Refresh:** To update the values displayed in the report.
- **Edit:** To edit the values displayed in the report.
- **Export:** To export data into multiple formats such as PDF, Excel, PowerPoint, and so on.

### Note

If IAC is enabled, only the configured dimension member codes will be displayed in the Revaluation Entries Report.

**Table 22-19 Revaluation Entries Report Information**

Report Name	Revaluation Entries
Report Description	<p>This report displays the following parameters of the selected entity:</p> <ul style="list-style-type: none"> <li>• <b>Run Identifier</b> : The Run Identifier is displayed here.</li> <li>• <b>As of Date</b>: The As of Date is displayed here.</li> <li>• <b>Accounting Entry Type Name</b>: The Accounting Entry Type Name is displayed here.</li> <li>• <b>Ledger Numeric Identifier</b>: The Ledger Numeric Identifier is displayed here.</li> <li>• <b>Debit Credit Indicator</b>: The Debit Credit Indicator is displayed here.</li> <li>• <b>Ledger Name</b>: The Ledger Name is displayed here.</li> <li>• <b>Legal Entity Code</b>: The Legal Entity Code is displayed here.</li> <li>• <b>Transaction Posting Date</b>: The Transaction Posting Date is displayed here.</li> <li>• <b>Account Currency Code</b>: The Account Currency Code is displayed here.</li> <li>• <b>.Account Currency Amount</b>: The Account Currency Amount is displayed here.</li> <li>• <b>Local Currency Code</b>: The Local Currency Code is displayed here.</li> <li>• <b>Local Currency Amount</b>: The Local Currency Amount is displayed here.</li> <li>• <b>Organization Unit</b>: The organization unit is displayed here.</li> <li>• <b>System of Record</b>: This is the system of record for data source code.</li> <li>• <b>GL Account Name</b>: The general ledger account name is displayed here.</li> <li>• <b>General Ledger Account Type</b>: The general ledger account type is displayed here.</li> <li>• <b>Instrument</b>: The instrument identifier is displayed here.</li> <li>• <b>Version</b>: This is the latest value corresponding to the instrument.</li> <li>• <b>Balance in Functional Currency</b>: This is the balance in the functional currency.</li> <li>• <b>Balance in Reporting Currency</b>: This is the balance in the reporting currency.</li> </ul>

### 22.8.2.3 Revaluation Execution

AFCS revaluation execution report provides the details such as the Total Credit, Total Debit and the Count of the revaluation entries.

Revaluation Execution report has the following filters:

- **Effective Date**: Click the calendar icon and select the Effective date.
- **Ledger Name**: Select the ledger name.
- **Run Identifier**: Select the run identifier.

After updating the options, click **Apply**. To refresh the data in the fields click **Reset**.

A few reports also have filters at each reporting level which are detailed in the **Report Descriptions** section. Select the appropriate report filters so that data is displayed accordingly. Each report within a dashboard contains the following features:

- **Analyze:** To analyze the values displayed in the report.
- **Refresh:** To update the values displayed in the report.
- **Edit:** To edit the values displayed in the report.
- **Export:** To export data into multiple formats such as PDF, Excel, PowerPoint, and so on.

**Note**

If IAC is enabled, only the configured dimension member codes will be displayed in the Revaluation Execution Report.

**Table 22-20 Revaluation Execution Report Information**

Report Name	Revaluation Execution
Report Description	<p>This report displays the following parameters of the selected entity:</p> <ul style="list-style-type: none"> <li>• Run Identifier: The Run Identifier is displayed here.</li> <li>• Effective Date: The Effective Date is displayed here.</li> <li>• Ledger Name: The Ledger Name is displayed here.</li> <li>• Account Currency Code: The Account Currency Code is displayed here.</li> <li>• Local Currency Code: The Local Currency Code is displayed here.</li> <li>• Total Credits: The Total Credits is displayed here.</li> <li>• Total Debits: The Total Debits is displayed here.</li> <li>• Count of Revaluation Entries: The Count of Revaluation Entries is displayed here.</li> <li>• Total Credits in LCY: The Total Credits in local currency is displayed here.</li> <li>• Total Debits in LCY: The Total Debits in local currency is displayed here.</li> </ul>

## 22.9 Account Summary

The dashboard will provide the detailed account information such as Account or Contract Number, Branch Code, End of Period Balance etc.

**Note**

In the AFCS Standard Edition, backward flow is not applicable and therefore Balance Computation and Balance Reconciliation are not supported. For more information, see the [About Accounting Foundation Cloud Service- Standard Edition](#).

## 22.9.1 Accessing the Standard Reports and Dashboards

To access the standard dashboards and reports in AFCS, complete the following steps:

1. On the Home Page, click **Dashboards** from the page header. You will see the basic summary reports.
2. From the list of summary reports, click **Account Summary** .

### 22.9.1.1 Report Descriptions

#### 22.9.1.1.1 Account Summary

This section provides information about the journal data information for 'Account Summary' used in Accounts Subject Area.

Account Summary report has the following filters:

- **As of Date:** Click the calendar icon and select the As of date.
- **Account Or Contract Number:** Select the account or contract number. This field is optional.

After updating the options, click **Apply**. To refresh the data in the fields click **Reset**.

A few reports also have filters at each reporting level which are detailed in the **Report Descriptions** section. Select the appropriate report filters so that data is displayed accordingly. Each report within a dashboard contains the following features:

- **Analyze:** To analyze the values displayed in the report.
- **Refresh:** To update the values displayed in the report.
- **Edit:** To edit the values displayed in the report.
- **Export:** To export data into multiple formats such as PDF, Excel, PowerPoint, and so on.

**Table 22-21 Account Summary Report Information**

Report Name	Accounting Journals
Report Description	<p>This report displays the following parameters of the selected entity:</p> <ul style="list-style-type: none"> <li>• As of Date: The As of Date is displayed here.</li> <li>• Account Or Contract Number: The Account Or Contract Number is displayed here.</li> <li>• Branch Code: The Branch Code is displayed here.</li> <li>• ISO Currency Code: The ISO Currency Code is displayed here.</li> <li>• Business Unit Code: The Business Unit Code is displayed here.</li> <li>• Data Source Code: The Data Source Code is displayed here.</li> <li>• General Ledger Account Code: The General Ledger Account Code is displayed here.</li> <li>• Legal Entity Code: The Legal Entity Code is displayed here.</li> <li>• Organization Unit Code: The Organization Unit Code is displayed here.</li> <li>• Product Code: The Product Code is displayed here.</li> <li>• Balance Sheet Category: The Balance Sheet Category is displayed here.</li> <li>• End of Period Balance: The End of Period Balance is displayed here.</li> <li>• Credit Status Description: The Credit Status Description is displayed here.</li> <li>• Region Description: The Region Description is displayed here.</li> </ul>

## 22.10 Transaction Summary

The transaction summary report provides details of a transaction such as Transaction Amount, Transaction Date, Transaction Reference Number etc.

### Note

In the AFCS Standard Edition, backward flow is not applicable and therefore Balance Computation and Balance Reconciliation are not supported. For more information, see the [About Accounting Foundation Cloud Service- Standard Edition](#).

### 22.10.1 Accessing the Standard Reports and Dashboards

To access the standard dashboards and reports in AFCS, complete the following steps:

1. On the Home Page, click **Dashboards** from the page header. You will see the basic summary reports.
2. From the list of summary reports, click **Transaction Summary**.

## 22.10.1.1 Report Descriptions

### 22.10.1.1.1 Transaction Summary

This section provides information about the journal data information for 'Transaction Summary' used in Transactions Subject Area.

Transaction Summary report has the following filters:

- **As of Date:** Click the calendar icon and select the As of date.
- **Transaction Reference Number:** Select the transaction reference number. This field is optional.

After updating the options, click **Apply**. To refresh the data in the fields click **Reset**.

A few reports also have filters at each reporting level which are detailed in the **Report Descriptions** section. Select the appropriate report filters so that data is displayed accordingly. Each report within a dashboard contains the following features:

- **Analyze:** To analyze the values displayed in the report.
- **Refresh:** To update the values displayed in the report.
- **Edit:** To edit the values displayed in the report.
- **Export:** To export data into multiple formats such as PDF, Excel, PowerPoint, and so on.

**Table 22-22 Transaction Summary Report Information**

Report Name	Transaction Summary
Report Description	<p>This report displays the following parameters of the selected entity:</p> <ul style="list-style-type: none"> <li>• As of Date: The As of Date is displayed here.</li> <li>• Account Or Contract Number: The Account Or Contract Number is displayed here.</li> <li>• Branch Code: The Branch Code is displayed here.</li> <li>• ISO Currency Code: The ISO Currency Code is displayed here.</li> <li>• Business Unit Code: The Business Unit Code is displayed here.</li> <li>• Data Source Code: The Data Source Code is displayed here.</li> <li>• General Ledger Account Code: The General Ledger Account Code is displayed here.</li> <li>• Legal Entity Code: The Legal Entity Code is displayed here.</li> <li>• Organization Unit Code: The Organization Unit Code is displayed here.</li> <li>• Product Code: The Product Code is displayed here.</li> <li>• Transaction Date: The Transaction Date is displayed here.</li> <li>• Event Identifier: The Event Identifier is displayed here.</li> <li>• Header Identifier: The Header Identifier is displayed here.</li> <li>• Transaction Amount: The Transaction Amount is displayed here.</li> <li>• Transaction Reference Number: The Transaction Reference Number is displayed here.</li> <li>• Transaction Purpose Code: The Transaction Purpose Code is displayed here.</li> <li>• Transaction Description: The Transaction Description is displayed here.</li> </ul>

## 22.11 Drill Back Capability

AFCS has configured report templates to optionally support establishing lineage of information it publishes from ERP Cloud FAH instances that its subscriber instances interface with in deployment. Data lineage from ERP Financials Accounting Hub Cloud to AFCS can be established if so desired via ERP Financials Cloud 'Configure & Extend' features and such AFCS report templates delivered via the service's Oracle Analytics instance.

### Note

The process sequences to populate AFCS Results structures must be completed before this lineage information to be available.

**Note**

In the AFCS Standard Edition, backward flow is not applicable and therefore Balance Computation and Balance Reconciliation are not supported. For more information, see the [About Accounting Foundation Cloud Service- Standard Edition](#).

## 22.11.1 Accounting Journals and Transaction Summary

The following steps have to be undertaken by subscribers to leverage this facility:

- Raise a Support Request on AFCS via My Oracle Support portal to obtain URL pattern for your AFCS Oracle Analytics instance stating 'ERP Financials Accounting Hub Cloud to AFCS Drill-through' as the headline subject.
- Perform Oracle Financials Cloud 'Configure & Extend' – 'Modify Pages' steps as per the user guide on Oracle Help Centre for the service.

Here is a summary of how such lineage will work:

- Follow ERP user documentation to perform configuration and extension to 'Accounting Journals and Transaction Summary' user interface.
- The URL will navigate to AFCS Oracle Analytics that lists the published journals or transactions information.

**Note**

This URL needs to be invoked from ERP Cloud FAH user interface with Header Group Identifier as the parameter.

**Figure 22-4 Account Journals Summary and Transaction Summary**

The screenshot shows a web interface titled "Accounting Journals and Transaction Summary". It contains two tables:

**Accounting Journals Summary**

Run Identifier	Header Group Identifier	As of Date	Account Or Contract Number	Accounting Standard Code	Ledger Numeric Identifier	Business Unit Code	Channel Code	Branch Code	Product Code	Organization Unit Code	Debit Credit Indicator	Ledger Name	Party Identifier
	100000000216698	20240216	ACCOUNT_1254	USGAAP	L2		8		PROFIN	ABJ	D	ABC1	ISSUER6

**Transaction Summary**

As Of Date	Header Group Identifier	Transaction Date	Account Or Contract Number	Branch Code	Business Unit Code	ISO Currency Code	Data Source Code	General Ledger Account Code	Legal
20240614	100000000216698	20201220	ACCOUNT_369	BRANCH_9	BU_1	GBP		LOANPAY	NOB/
			ACCOUNT_377	BRANCH_17	BU_1	EUR		RETERNGS	NOB/
		20210210	ACCOUNT_318	BRANCH_6	BU_6	GBP		CSH	NOB/
		20210520	ACCOUNT_377	BRANCH_17	BU_1	EUR		RETERNGS	NOB/
		20210730	ACCOUNT_1194	BRANCH_18	BU_2	GBP		SERREV	NOB/
		20210830	ACCOUNT_1234	BRANCH_19	BU_3	INR		CMNSTCK	NOB/
		20210910	ACCOUNT_377	BRANCH_17	BU_1	EUR		RETERNGS	NOB/
		20210920	ACCOUNT_399	BRANCH_15	BU_7	GBP		ACCPAY	NOB/
		20211220	ACCOUNT_493	BRANCH_13	BU_5	INR		INTPAY	NOB/
		20221210	ACCOUNT_229	BRANCH_13	BU_5	INR		UTILEXP	NOB/

**Note**

If Information Access Control is enabled, only the configured dimension member codes will be displayed in the Accounting Journal summary report.

## 22.11.2 Transaction Details Report

A new drill-down capability, 'Transaction Details' Report for a Drill Through from AHCS to AFCS based on Accounting Hub Journal Line Number enables users to seamlessly navigate from AHCS to a detailed sourced transactions based on AH Journal Line Number, significantly improving visibility and traceability. The benefits are as follows:

1. Transparency and Traceability - Well defined drill back process that allows users to drill-back at the click of a button from grouped journals in AHCS to underlying transactions in AFCS.
2. Error Detection - Increase speed to resolution, allowing users to investigate and remediate issues faster.
3. Complete end-to-end drill back - Increased auditability from GL Balances to source transaction. Ensures trust and confidence in the flow of data.

The following steps have to be undertaken by subscribers to leverage this facility:

- Raise a Support Request on AFCS via My Oracle Support portal to obtain URL pattern for your AFCS Oracle Analytics instance stating 'Transaction Details' as the headline subject.
- Perform Oracle Financials Cloud 'Configure & Extend' – 'Modify Pages' steps as per the user guide on Oracle Help Centre for the service.

Here is a summary of how such lineage will work:

- Follow ERP user documentation to perform configuration and extension to 'View Journal Entry' user interface.
- The URL will navigate to AFCS Oracle Analytics report that lists the sourced transactions information.

**Note**

This URL needs to be invoked from ERP Cloud FAH user interface with Journal line number as the parameter.

**Figure 22-5 ERP Journal Lines Details**

Line	Account	Entered	Accounted (USD)		Accounting Class	Line Description	St	Re
			Debit	Credit				
1	LE002 CROUS BL018 GL40011 BR002 INV0002 CRIBANK CD0101 CD0201 FU FU FU		80.00000 ANG	40.00000	Expense	800025751000000003 Click for Detailed Report		
2	LE002 CROUS BL018 GL30008 BR002 INV0002 CRIBANK CD0101 CD0201 FU FU FU			40.00000 ANG	Revenue	800025751000000003 Click for Detailed Report		
Total				40.00000	40.00000			

Figure 22-6 AFCS Transaction Details Report

ALIST Date	PRODUCT CODE	Transaction Date	Account Or Contract Number	BRANCH CODE	BUSINESS UNIT CODE	ISO CURRENCY CODE	DATES SOURCE CODE	GENERAL LEDGER ACCOUNT CODE	Legal Entity Code	Organization Unit Code	Header Identifier	Event Identifier	Transaction Purpose Code	Transaction Description	Transaction Reference Number	Transaction Amount	APL LINE NUMBER
20200002	M55	20200902	9V1010210310000009	M55	M55		ORIGAL	M55	M55		T_1_1	T_1_1	M55		T_1_1_1_1	40.00	900000791000000000
											T_1_1_1	T_1_1_1	M55		T_1_1_1_1	40.00	900000791000000000

## 22.12 Fact Common Policy Summary

Fact Common Policy Summary has been added as a new Subject Area to the OBIEE layer. Users can create customizable reports.

# 23

## Data Extraction

You can access data extraction definitions by accessing the AFCS User Interface. On the Home page, from the Left Hand Side menu, click **Data Extraction**. This displays basic details of the Extract definitions. AFCS supports user-configured extraction of data from Staging and Results entities via Connectors.

### Note

If the Extraction Entity contains the **As Of Date** column, the data will be filtered based on the PMF execution date. When no date is selected during PMF Execution, the data will be filtered based on the current date.

To extract all the active nodes, the default filter applied for the dimension extract is "Execution Date between Record Start Date and Record End Date" instead of "As of date".

As the PMF execution date will be picked up as the default date for the extraction, you are not expected to provide a filter on **As of Date** during connector creation.

### Note

In the AFCS Standard Edition, backward flow is not applicable and therefore Sys ML Latest Balances Extracts are not supported. For more information, see the [About Accounting Foundation Cloud Service- Standard Edition](#).

## 23.1 Adding a Data Extraction

To add a Data Extraction, follow these steps:

1. From the **AFCS Home** page, select **Data Extraction**.  
The **Summary** page is displayed with a list of data extraction definitions.
2. Click **Add**.  
The **Specify Details** window appears.
3. Enter the **Name** for the Data Extraction.  
For Example: Extract CASA.
4. Enter the **Description** of the Data Extraction.  
This field is optional.
5. Select the **Grain** from the drop-down list.  
For Example: Customer Account.
6. Select the **Entity** from the drop-down list.  
For Example: Casa

7. Enter the required filter expression for the Data Extraction. In addition, you can also add Parameters.

This field is optional.

For Example: [Casa].[Account or Contract Number] is not null.

This filters out rows where the account or contract number is not null.

**Note**

For filtering data on Dimension Codes, you can specify member values for dimension surrogate key attributes only for the result table entities.

8. Click **Validate** to verify the correctness of the SQL Expression and click **OK**.

The filter expression is displayed in the **Expression** text box.

9. Navigate to the **Select Attributes** page.

The **Attributes list** displays the list of attributes that can be associated with the Data Extraction. The attribute list shows the combined attributes for all the tables selected.

10. Select the attributes and click **OK**.

Select or unselect the attributes by clicking the respective icons. You can also drag and drop to rearrange the attributes in the **Selected Attributes** section.

**Note**

You can select a maximum of 998 attributes.

**Note**

You can click Edit icon and rename the header attribute name, if required.

**Note**

Post upgrade, attributes of existing result entity extract connectors must be de-selected and selected again to auto rename attributes and validation on duplicate columns in selected attributes.

For new connectors, attributes will be automatically renamed when selected. Auto-renaming of attributes to its corresponding dimension code attributes in the user interface is done only for Result table surrogate keys.

Out-of-the-Box or custom attributes common across multiple dimension entities will not be displayed in the Select Attributes list. Related entities linked to the primary entity that do not have child attributes will not be displayed from the connector definition.

11. Navigate to the **Describe File** page.
12. In **Specify Data file names**, enter the file name. This is a mandatory field.

For example: test\_file\_data.txt

**Note**

The file extension must be either .txt or .csv.

13. Select **Column delimiter** from the drop down list.  
For Example: Comma
14. Specify the **Text qualifier**.  
For Example: Double quotes can be used, prefixed, and suffixed with text.
15. Select the **file format**.  
For Example: Fixed Length or Delimited.
16. Select the **Record delimiter**.  
For Example: Unix
17. Toggle the **Header** button if you want a header to be displayed in the extracted file.  
This field is optional.

**Note**

The extracted file will show Result, Dimension, Integration, and Staging tables. Currently, Processing layer tables are not supported.

In case two physical entities contain the same logical name, the order of preference for the entity will be in the following order:

- 1 - Result
- 2 - Dimension
- 3 - Integration
- 4 - Staging

18. Toggle the **Generate a control file** button if you want to generate a control file. The control file provides verification/validation information for use with extracted data files.

This field is optional.

In the **Specify control file name** field, enter the file name. This is a mandatory field. The file extension must be either .txt or .csv.

The parameters you entered for **Specify Data file names** are copied to the Control file properties. You can modify based on your requirements. By default, the name is added as **< Specify Data file names >\_control.csv/.txt**. For more details on fields such as Select file format, Select Column delimiter, Select Record delimiter, and Specify Text qualifier, see the above step.

To add the controls, click Add button.

- Add the control name in the text box.
- Select the aggregation type from the dropdown. The supported options are Count, Avg, Sum, Min, and Max.
- Select the attribute from the drop-down. The Attribute field is disabled when the aggregation type is selected as Count. The numerical attributes supports the

aggregation type Sum, Average, Min, and Max. The Date attribute supports the aggregation type Min and Max only.

You can add multiple controls to the file by clicking on Add button.

The Control file is available in the Archived Extract file.

#### Note

The following are the behavior of the Control file in this release:

- There is no validations performed while generating a control file.
- Header will not be generated in case of control file during data extraction and you will not have an option to add the header.

#### 19. Click **Save**.

The Data Extraction Definition is created.

#### 20. After the Data Extraction is saved, the PMF process needs to be configured and executed. For more details, see [Executing Connector using Process Modelling Framework](#)

The Data Extraction file is created.

#### 21. Download the file from the File Operations screen. For more details, see [File Operations](#).

## 23.2 OOTB Extract for Management Ledger

For the Management ledger, there will be an extract definition **Sys ML Balance Extract** as an out-of-the-box extract.

To view or modify the extract definitions:

#### 1. From the **AFCS Home** page, select **Data Extraction**.

The **Summary** page is displayed with a list of data extraction definitions.

#### 2. Select **Sys ML Balance Extract** by searching for it. Click to view details of this extract.

#### Note

You cannot modify the Name, Description, Grain, and Entity.

#### 3. User will have the option to apply a filter on Management Ledger tables and Hierarchy tables.

#### Note

Selecting the Hierarchy parent will be available only for this out-of-the-box extract but not for other custom extracts.

**Note**

User can apply filters on Hierarchy codes of General Ledger Hierarchy and Business Unit Hierarchy when alternative hierarchies exists to avoid duplication in extraction data.

Following is an example filter expression (Replace the <HIERARCHY\_CODE> with the respective codes):

```
[Business Unit Hierarchy].[Hierarchy Code] = '<HIERARCHY_CODE>' AND  
[General Ledger Hierarchy].[Hierarchy Code] ='<HIERARCHY_CODE>'
```

4. Click **Select Attributes**. The following attributes are added in **Computed** section under **Available Attributes**.
  - Parent GL Account Code
  - Parent Business Unit Code
  - Parent Business Unit Description
  - Intercompany Identifier Description
5. Click **Describe File**.
6. In **Specify Data file names**, enter the file name. This is a mandatory field.  
For example: test\_file\_data.txt

**Note**

The file extension must be either .txt or .csv.

7. Select **Column delimiter** from the drop down list.  
For Example: Comma
8. Specify the **Text qualifier**.  
For Example: Double quotes can be used, prefixed, and suffixed with text.
9. Select the **file format**.  
For Example: Fixed Length or Delimited.
10. Select the **Record delimiter**.  
For Example: Unix
11. Toggle the **Header** button if you want a header to be displayed in the extracted file.  
This field is optional.

**Note**

The extracted file will show Result, Dimension, Integration, and Staging tables. Currently, Processing layer tables are not supported.

In case two physical entities contain the same logical name, the order of preference for the entity will be in the following order:

- 1 - Result
- 2 - Dimension
- 3 - Integration
- 4 - Staging

12. Toggle the **Generate a control file** button if you want to generate a control file. The control file provides verification/validation information for use with extracted data files.

This field is optional.

In the **Specify control file name** field, enter the file name. This is a mandatory field. The file extension must be either .txt or .csv.

The parameters you entered for **Specify Data file names** are copied to the Control file properties. You can modify based on your requirements. By default, the name is added as **< Specify Data file names >\_control.csv/.txt** . For more details on fields such as Select file format, Select Column delimiter, Select Record delimiter, and Specify Text qualifier, see the above step.

To add the controls, click Add button.

- Add the control name in the text box.
- Select the aggregation type from the drop down. The supported options are Count, Avg, Sum, Min, and Max.
- Select the attribute from the drop-down. The Attribute field is disabled when the aggregation type is selected as Count.

You can add multiple controls to the file by clicking on Add button.

The Control file is available in the Archived Extract file.

**Note**

The following are the behavior of the Control file in this release:

- There is no validations performed while generating a control file.
- Header will not be generated in case of control file during data extraction and you will not have an option to add the header.

13. Click **Save**.

The **Sys ML Balance Extract** definition is updated.

14. For this seeded connector, you must create a pipeline to execute.

**Note**

The attributes common across Management Ledger Period Balances and Management Ledger COA Segments entities are exposed for extraction. You can select and de-select the common attributes across these entities.

**Note**

Out-of-the-Box or custom attributes common across multiple dimension entities will not be displayed in the Select Attributes list. Related entities linked to the primary entity that do not have child attributes will not be displayed from the connector definition.

## 23.3 OOTB Extract for Management Ledger As Of Date

For the Management ledger, there will be an extract definition **Sys ML Balance Extract As Of Date** as an out-of-the-box extract.

Management Ledger balance data As Of Date per ledger will be available with:

- all relevant segments
- audit attributes
- parent information for General Ledger & Business Unit
- Balance Update Start and End time

To view or modify the extract definitions:

1. From the **AFCS Home** page, select **Data Extraction**.

The **Summary** page is displayed with a list of data extraction definitions.

2. Select **Sys ML Balance Extract As Of Date** by searching for it. Click to view details of this extract.

**Note**

You cannot modify the Name, Description, Grain, and Entity.

3. User will have the option to apply a filter on Management Ledger tables and Hierarchy tables.

**Note**

Note that selecting the Hierarchy parent will be available only for this out-of-the-box extract but not for other custom extracts.

4. Click **Select Attributes**. The following attributes are added in **Computed** section under **Available Attributes**.

- Parent GL Account Code
- Parent Business Unit Code
- Parent Business Unit Description

- Intercompany Identifier Description
  - Balance Update Start Time
  - Balance Update End Time
5. Click **Describe File**.
  6. In **Specify Data file names**, enter the file name. This is a mandatory field.  
For example: test\_file\_data.txt

**Note**

The file extension must be either .txt or .csv.

7. Select **Column delimiter** from the drop down list.  
For Example: Comma
8. Specify the **Text qualifier**.  
For Example: Double quotes can be used, prefixed, and suffixed with text.
9. Select the **file format**.  
For Example: Fixed Length or Delimited.
10. Select the **Record delimiter**.  
For Example: Unix
11. Toggle the **Header** button if you want a header to be displayed in the extracted file.  
This field is optional.

**Note**

The extracted file will show Result, Dimension, Integration, and Staging tables. Currently, Processing layer tables are not supported.

In case two physical entities contain the same logical name, the order of preference for the entity will be in the following order:

- 1 - Result
- 2 - Dimension
- 3 - Integration
- 4 - Staging

12. Toggle the **Generate a control file** button if you want to generate a control file. The control file provides verification/validation information for use with extracted data files.  
This field is optional.

In the **Specify control file name** field, enter the file name. This is a mandatory field. The file extension must be either .txt or .csv.

The parameters you entered for **Specify Data file names** are copied to the Control file properties. You can modify based on your requirements. By default, the name is added as **< Specify Data file names >\_control.csv/.txt**. For more details on fields such as Select file format, Select Column delimiter, Select Record delimiter, and Specify Text qualifier, see the above step.

To add the controls, click Add button.

- Add the control name in the text box.
- Select the aggregation type from the dropdown. The supported options are Count, Avg, Sum, Min, and Max.
- Select the attribute from the drop-down. The Attribute field is disabled when the aggregation type is selected as Count.

You can add multiple controls to the file by clicking on Add button.

The Control file is available in the Archived Extract file.

#### Note

The following are the behavior of the Control file in this release:

- There is no validations performed while generating a control file.
- Header will not be generated in case of control file during data extraction and you will not have an option to add the header.

#### 13. Click **Save**.

The **Sys ML Balance Extract As Of Date** definition is updated.

#### 14. For this seeded connector, you must create a pipeline to execute. You must pass a value for LEDGER\_ID during execution.

#### Note

For more information on Connectors, see the [Connectors](#) section.

#### Note

The attributes common across Management Ledger Period Balance And Movement, and Management Ledger COA Segment Combination COA Segments entities are exposed for extraction. You can select and de-select the common attributes across these entities.

#### Note

Incremental data extraction is supported for Management Ledger As Of Date Connector.

#### Note

Out-of-the-Box or custom attributes common across multiple dimension entities will not be displayed in the Select Attributes list. Related entities linked to the primary entity that do not have child attributes will not be displayed from the connector definition.

## 23.4 OOTB Extract for Management Ledger As Of Effective Date

For the Management ledger, there will be an extract definition **Sys ML Balance Extract As Of Effective Date** as an out-of-the-box extract.

Management Ledger balance data As of Effective Date per ledger will be available with:

- all relevant segments
- audit attributes
- parent information for General Ledger & Business Unit
- Balance Update Start and End time

To view or modify the extract definitions:

1. From the **AFCS Home** page, select **Data Extraction**.

The **Summary** page is displayed with a list of data extraction definitions.

2. Select **Sys ML Balance Extract As Of Effective Date** by searching for it. Click to view details of this extract.

### Note

You cannot modify the Name, Description, Grain, and Entity.

3. User will have the option to apply a filter on Management Ledger tables and Hierarchy tables.

### Note

Note that selecting the Hierarchy parent will be available only for this out-of-the-box extract but not for other custom extracts.

4. Click **Select Attributes**. The following attributes are added in **Computed** section under **Available Attributes**.

- Parent GL Account Code
- Parent Business Unit Code
- Parent Business Unit Description
- Intercompany Identifier Description
- Balance Update Start Time
- Balance Update End Time

5. Click **Describe File**.

6. In **Specify Data file names**, enter the file name. This is a mandatory field.

For example: test\_file\_data.txt

### Note

The file extension must be either .txt or .csv.

7. Select **Column delimiter** from the drop down list.  
For Example: Comma
8. Specify the **Text qualifier**.  
For Example: Double quotes can be used, prefixed, and suffixed with text.
9. Select the **file format**.  
For Example: Fixed Length or Delimited.
10. Select the **Record delimiter**.  
For Example: Unix
11. Toggle the **Header** button if you want a header to be displayed in the extracted file.  
This field is optional.

**Note**

The extracted file will show Result, Dimension, Integration, and Staging tables. Currently, Processing layer tables are not supported.

In case two physical entities contain the same logical name, the order of preference for the entity will be in the following order:

- 1 - Result
- 2 - Dimension
- 3 - Integration
- 4 - Staging

12. Toggle the **Generate a control file** button if you want to generate a control file. The control file provides verification/validation information for use with extracted data files.

This field is optional.

In the **Specify control file name** field, enter the file name. This is a mandatory field. The file extension must be either .txt or .csv.

The parameters you entered for **Specify Data file names** are copied to the Control file properties. You can modify based on your requirements. By default, the name is added as **< Specify Data file names >\_control.csv/.txt**. For more details on fields such as Select file format, Select Column delimiter, Select Record delimiter, and Specify Text qualifier, see the above step.

To add the controls, click Add button.

- Add the control name in the text box.
- Select the aggregation type from the dropdown. The supported options are Count, Avg, Sum, Min, and Max.
- Select the attribute from the drop-down. The Attribute field is disabled when the aggregation type is selected as Count.

You can add multiple controls to the file by clicking on Add button.

The Control file is available in the Archived Extract file.

**Note**

The following are the behavior of the Control file in this release:

- There is no validations performed while generating a control file.
- Header will not be generated in case of control file during data extraction and you will not have an option to add the header.

**13. Click Save.**

The **Sys ML Balance Extract As Of Effective Date** definition is updated.

**14. For this seeded connector, you must create a pipeline to execute. You must pass a value for LEDGER\_ID during execution.****Note**

For more information on Connectors, see the [Connectors](#) section.

**Note**

The attributes common across Management Ledger Period Balance And Movement, and Management Ledger COA Segment Combination COA Segments entities are exposed for extraction. You can select and de-select the common attributes across these entities.

**Note**

Incremental data extraction is supported for Management Ledger As Of Effective Date Connector.

**Note**

Out-of-the-Box or custom attributes common across multiple dimension entities will not be displayed in the Select Attributes list. Related entities linked to the primary entity that do not have child attributes will not be displayed from the connector definition.

## 23.5 Extracting the maximum version of ML balances

To extract maximum version of ML balances for a given contract and CoA combination, follow these steps:

1. Navigate to **Data Extraction Summary** page to edit the **Sys ML Balance Extract** OOTB connector. Add the filter expression **[Management Ledger Period Balance].[Run Identifier] = '#DIH.runskey'** and **[Management Ledger Period Balance].[Effective Date] = '#DIH.MIS\_DATE'** on Effective Date and Run Identifier of Management Ledger Period Balances entity and save the connector definition.

**Note**

To extract the latest balances, execute the following pipelines:

- Execute the Balance Computation Management Ledger Incremental Results Area Load pipeline and then execute the incremental named extract connectors.
- For the Sys ML Balance connectors such as **Sys ML Balance Extract as of Date** and **Sys ML Balance Extract as of Effective Date**, the filter expression to extract the latest balances is - **[Management Ledger Period Balance And Movement].[Run Surrogate Key] - '#DIH.WF\_OBJECT\_ID'** .

**Note**

For the Data Quality Error Report extract connector, the filter expression to extract the latest error records is - **[Data Quality Error Records].[Run Surrogate Key] = '#DIH.WF\_OBJECT\_ID'**.

2. Create a custom PMF with a data service linked to the connector.

**Note**

For more information on Connectors, see the [Connectors](#) section.

**Note**

For the Data Quality Error Report connector, in a custom PMF, follow the sequence as adding the DQ component, and then the DQ Reporting Engine, and finally linking them to the connector component.

3. Edit the Data service and select the data service name as **Integration Management Ledger Periodic Balances**.

**Note**

Select the data service as RA Management Ledger Period Balance Movement for the connectors **Sys ML Balance Extract as of Date** and **Sys ML Balance Extract as of Effective Date**.

4. Edit the connector and select the **Sys ML Balance Extract** OOTB connector. Enter the MIS\_DATE runtime variable expression as **MIS\_DATE = \$MISDATE:dd-MMM-yyyy** and save the custom PMF pipeline.
5. Execute the custom PMF pipeline with a MIS\_DATE.

**Note**

Selecting the Hierarchy parent will be available only for this out-of-the-box extract.

## 23.6 OOTB Extract for Data Quality Error Report

For the Data Quality Error Records, there will be an extract definition **Data Quality Error Report** as an out-of-the-box extract.

To view or modify the extract definitions:

1. From the **AFCS Home** page, select **Data Extraction**.  
The **Summary** page is displayed with a list of data extraction definitions.
2. Select **Data Quality Error Report** by searching for it. Click to view details of this extract.

### Note

You cannot modify the Name, Description, Grain, and Entity.

3. User will have the option to apply a filter on Data Quality Error Records table.
4. Click **Select Attributes**. The following attributes are added in **Computed** section under **Available Attributes**.
  - Data Quality Error Record Identifier Name One
  - Data Quality Error Record Identifier Name Two
  - Data Quality Error Record Identifier Name Three
  - Data Quality Error Record Identifier Name Four
  - Data Quality Error Record Identifier Name Five
  - Data Quality Error Record Identifier Name Six
  - Data Quality Error Record Identifier Name Seven
  - Data Quality Error Record Identifier Name Eight
  - Data Quality Entity Name
  - Data Quality Entity Attribute Name

### Note

Out-of-the-Box or custom attributes common across multiple dimension entities will not be displayed in the Select Attributes list. Related entities linked to the primary entity that do not have child attributes will not be displayed from the connector definition.

5. Click **Describe File**.
6. In **Specify Data file names**, enter the file name. This is a mandatory field.  
For example: test\_file\_data.txt

### Note

The file extension must be either .txt or .csv.

7. Select **Column delimiter** from the drop down list.

For Example: Comma

8. Specify the **Text qualifier**.

For Example: Double quotes can be used, prefixed, and suffixed with text.

9. Select the **file format**.

For Example: Fixed Length or Delimited.

10. Select the **Record delimiter**.

For Example: Unix

11. Toggle the **Header** button if you want a header to be displayed in the extracted file.

This field is optional.

**Note**

The extracted file will show Result, Dimension, Integration, and Staging tables. Currently, Processing layer tables are not supported.

In case two physical entities contain the same logical name, the order of preference for the entity will be in the following order:

- 1 - Result
- 2 - Dimension
- 3 - Integration
- 4 - Staging

12. Toggle the **Generate a control file** button if you want to generate a control file. The control file provides verification/validation information for use with extracted data files.

This field is optional.

In the **Specify control file name** field, enter the file name. This is a mandatory field. The file extension must be either .txt or .csv.

The parameters you entered for **Specify Data file names** are copied to the Control file properties. You can modify based on your requirements. By default, the name is added as **< Specify Data file names >\_control.csv/.txt** . For more details on fields such as Select file format, Select Column delimiter, Select Record delimiter, and Specify Text qualifier, see the above step.

To add the controls, click Add button.

- Add the control name in the text box.
- Select the aggregation type from the drop-down. The supported options are Count, Avg, Sum, Min, and Max.
- Select the attribute from the drop-down. The Attribute field is disabled when the aggregation type is selected as Count.

You can add multiple controls to the file by clicking on Add button.

The Control file is available in the Archived Extract file.

**Note**

The following are the behavior of the Control file in this release:

- There is no validations performed while generating a control file.
- Header will not be generated in case of control file during data extraction and you will not have an option to add the header.

**13. Click Save.**

The **Data Quality Error Report** definition is updated.

**14. For this seeded connector, you must create a pipeline to execute.**

## 23.6.1 Extracting the Data Quality Error Records

To extract the Data Quality Error Records, follow these steps:

1. Navigate to **Data Extraction Summary** page to edit the **Data Quality Error Report** OOTB connector. Add the filter expression **[Data Quality Error Records].[Run Surrogate Key] = '#DIH.WF\_OBJECT\_ID'** on Run Identifier of Data Quality Error Records and save the connector definition.
2. Create a custom PMF with a Data Quality Rules and Data Quality Reporting Engine linked to the connector.
3. Execute the custom PMF pipeline with a MIS DATE.
  - The DQ reporting engine will populate to new DQ results area.
  - DQ reports will work out of the DQ results area. DQ reports for execution dates prior to the 24A version will not show any data.
  - DQ error records for previous DQ execution dates if essential and critical can be migrated on a request basis post 24A upgrade. Raise service request with details of business criticality.

## 23.7 OOTB Extract for Period Day YTD Balance

For the Management ledger, there will be PMF process **Period Day YTD Balance Extraction** as an out-of-the-box to extract Period Day YTD Balance. The process allows users to generate an extract with YTD balance for each Day in a period for all management ledger segment combinations.

**Note**

This extract needs to be always generated through the **Period Day YTD Balance Extraction** PMF process.

### 23.7.1 Prerequisite

Before executing the Period Day YTD Balance Extraction process, ensure that the Balance Computation Management Ledger Incremental Results Area Load pipeline and the Fiscal period setup is completed and compiled. For more details, see the [Fiscal Period](#) and the **Results Entity** section in the *AFCS Data Catalog User Guide*.

## 23.7.2 Period Day YTD Balance Extraction Process

The Period Day YTD Balance Extraction process consists of components that perform the following tasks:

1. Management Ledger Period YTD Balance - This connector picks the latest balances from Management Ledger Period Balance And Movement Result table and populates Management Ledger Period Year To Date Balance Result table for all days in a given period.
2. Period YTD Balance Extract - Extracts period day YTD balance from the Result Area to a file and uploads to object store which can be downloaded from the **Administration > File Operations** screen.

Sample file name: ml\_ytd\_balance.csv

## 23.7.3 Executing Period Day YTD Balance Extraction Process

To view and execute the Period Day YTD Balance Extraction Process, complete the following steps:

1. On the Home page, click the **Process Orchestration** link on the left.
2. Search for the **Period Day YTD Balance Extraction** process.
3. From the Process Modeller Summary page, click the menu button corresponding to Period Day YTD Balance Extraction and select **Execute Run**.
4. Select the Execution Type as **With Parameters**, and select **Fiscal Period**, **As Of Date**, **Fiscal Period Month** parameters and click **Execute**.

For more details on how to view the execution status in the Process Monitor window, see the [Managing Processes](#) section.

## 23.7.4 Incremental Extract for Period Day YTD Balance

A new component called **Data Transform** has been introduced to support incremental processing for **Period Day YTD Balance**. This component must be executed prior to running the **Incremental YTD Extract** process.

The incremental process allows users to extract Period Day YTD Balance data for incremental runs by utilizing the processing run identifier generated by the Data Transform component.

### 23.7.4.1 Prerequisite

Before executing the Incremental Extract for Period Day YTD Balance process, ensure that:

- The Balance Computation Management Ledger Incremental Results Area Load pipeline is completed.
- The Fiscal Period setup is completed and compiled.
- The Data Transform component is configured in the pipeline with the correct process type.
- The required MISDATE is available for execution.

### 23.7.4.2 Configuring the Incremental PTD Balance Process

To configure the Incremental PTD Balance process, follow these steps:

1. On the Home page, click **Process Orchestration**.
2. From the Process Modeller page, search for the required pipeline and navigate to the Process canvas page.
3. Add the **DATA\_TRANSFORM** widget to the required pipeline.
4. In the **Process Type** field, enter **INCR\_PTD\_BALANCE**.

**Note**

The Process Type field only supports the value **INCR\_PTD\_BALANCE**.

5. In the Activity Details window, click **Save** to save the component and then Click **Save** to save the pipeline in the Process canvas page.
6. Add the new pipeline to the orchestration sequence.
7. Ensure that the **DATA\_TRANSFORM** pipeline is placed before the Incremental YTD Extract process.
8. While executing the process, provide the required MISDATE in the **As of Date** field.

### 23.7.4.3 Incremental Period Day YTD Balance Process

The Incremental Period Day YTD Balance process consists of components that perform the following tasks:

- Data Transform - Processes the incremental PTD Balance data for the specified MISDATE and prepares the run-specific data set required for extraction.
- Sys ML Period YTD Balance Extract - Extracts the Period Day YTD Balance data from the Results Area based on the incremental processing run and generates an output file.

The extract file can then be uploaded to an Object Store and downloaded from the **File Operations** User Interface under **Administration**.

### 23.7.4.4 Executing the Incremental Period Day YTD Balance Process

To execute the Incremental Period Day YTD Balance process, follow these steps:

1. On the Home page, click the **Process Orchestration**.
2. Search for the pipeline that is configured for incremental PTD Balance processing.
3. Enter the required parameters and execute the pipeline.
4. In the **As of Date** field, enter the required MISDATE.
5. After the Data Transform step is completed, run the **Sys ML Period YTD Balance Extract** process.
6. In the extract filter, use the Object ID of the Data Transform job to perform the incremental extract.
7. Apply additional filters to refine the extract output, if required (This is optional).

### 23.7.4.5 Verifying the Pipeline

Before execution, verify that the Incremental YTD pipeline is configured correctly. Ensure the following:

- The DATA\_TRANSFORM widget is included in the pipeline.

- The Process Type field is set to INCR\_PTD\_BALANCE.
- The pipeline is added to the orchestration sequence.
- The DATA TRANSFORM step is placed before the Incremental YTD Extract step
- The extract configuration uses the Object ID of the Data Transform job for incremental extraction.

### 23.7.4.6 Snapshot PTD and Incremental PTD Execution Guidelines

The Snapshot PTD process and the incremental PTD process are complementary and must be used as follows:

- The Snapshot PTD process must be executed at the beginning of each fiscal period.
- Snapshot PTD population remains mandatory and must be executed once at the beginning of every fiscal period.
- Snapshot PTD population can be executed after Beginning of the Day results population.
- Snapshot PTD population can also be executed later within the same fiscal period, if required.
- Execution of the incremental PTD process does not impact the snapshot PTD population.
- Execution of the snapshot PTD process does not impact the incremental PTD process.

### 23.7.4.7 Extract Parameters

Extracts can be generated either for a fiscal period or for a specific run, depending on the process that is being executed.

- For snapshot PTD extraction, provide the fiscal period parameter.
- For incremental PTD extraction, provide the run skey associated with the Data Transform job.

## 23.8 OOTB Latest Balances Extract for Management Ledger As Of Date

For the Management ledger, there will be an extract definition **Sys ML Latest Balance Extract As Of Date** as an out-of-the-box extract. This seeded Data Extraction will provide the latest balances for a given As Of Date and Ledger.

Management Ledger latest balance data As Of Date per ledger will be available with:

- all relevant segments
- audit attributes
- parent information for General Ledger & Business Unit
- Balance Update Start and End time

To view or modify the extract definitions:

1. From the **AFCS Home** page, select **Data Extraction**.

The **Summary** page is displayed with a list of data extraction definitions.

2. Select **Sys ML Latest Balance Extract As Of Date** by searching for it. Click to view details of this extract.

**Note**

You cannot modify the Name, Description, Grain, and Entity.

3. User will have the option to apply a filter on Management Ledger tables and Hierarchy tables.

**Note**

Note that selecting the Hierarchy parent will be available only for this out-of-the-box extract but not for other custom extracts.

4. Click **Select Attributes**. The following attributes are added in **Computed** section under **Available Attributes**.
  - Parent GL Account Code
  - Parent Business Unit Code
  - Parent Business Unit Description
  - Intercompany Identifier Description
  - Balance Update Start Time
  - Balance Update End Time

**Note**

Out-of-the-Box or custom attributes common across multiple dimension entities will not be displayed in the Select Attributes list. Related entities linked to the primary entity that do not have child attributes will not be displayed from the connector definition.

5. Click **Describe File**.
6. In **Specify Data file names**, enter the file name. This is a mandatory field.  
For example: sys\_ml\_latest\_bal\_as\_of\_date\_%#LEDGER\_ID%.csv

**Note**

The file extension must be either .txt or .csv.

7. Select **Column delimiter** from the drop down list.  
For Example: Comma
8. Specify the **Text qualifier**.  
For Example: Double quotes can be used, prefixed, and suffixed with text.
9. Select the **file format**.  
For Example: Fixed Length or Delimited.
10. Select the **Record delimiter**.  
For Example: Unix

11. Toggle the **Header** button if you want a header to be displayed in the extracted file.

This field is optional.

**Note**

The extracted file will show Result, Dimension, Integration, and Staging tables. Currently, Processing layer tables are not supported.

In case two physical entities contain the same logical name, the order of preference for the entity will be in the following order:

- 1 - Result
- 2 - Dimension
- 3 - Integration
- 4 - Staging

12. Toggle the **Generate a control file** button if you want to generate a control file. The control file provides verification/validation information for use with extracted data files.

This field is optional.

In the **Specify control file name** field, enter the file name. This is a mandatory field. The file extension must be either .txt or .csv.

The parameters you entered for **Specify Data file names** are copied to the Control file properties. You can modify based on your requirements. By default, the name is added as **< Specify Data file names >\_control.csv/.txt**. For more details on fields such as Select file format, Select Column delimiter, Select Record delimiter, and Specify Text qualifier, see the above step.

To add the controls, click Add button.

- Add the control name in the text box.
- Select the aggregation type from the dropdown. The supported options are Count, Avg, Sum, Min, and Max.
- Select the attribute from the drop-down. The Attribute field is disabled when the aggregation type is selected as Count.

You can add multiple controls to the file by clicking on Add button.

The Control file is available in the Archived Extract file.

**Note**

The following are the behavior of the Control file in this release:

- There is no validations performed while generating a control file.
- Header will not be generated in case of control file during data extraction and you will not have an option to add the header.

13. Click **Save**.

The **Sys ML Latest Balance Extract As Of Date** definition is updated.

14. For this seeded connector, you must create a pipeline to execute. You must pass a value for LEDGER\_ID during execution.

**Note**

For more information on Connectors, see the [Connectors](#) section.

**Note**

The attributes common across Management Ledger Period Balance And Movement, and Management Ledger COA Segment Combination COA Segments entities are exposed for extraction. You can select and de-select the common attributes across these entities.

**Note**

Incremental data extraction is supported for Management Ledger Latest Balance As Of Date Connector.

## 23.9 OOTB Latest Balances Extract for Management Ledger As Of Effective Date

For the Management ledger, there will be an extract definition **Sys ML Latest Balance Extract As Of Effective Date** as an out-of-the-box extract. This seeded Data Extraction will provide the latest balances for a given Effective Date and Ledger. Management Ledger latest balance data for a given Effective Date per ledger will be available with:

- all relevant segments
- audit attributes
- parent information for General Ledger & Business Unit
- Balance Update Start and End time

To view or modify the extract definitions:

1. From the **AFCS Home** page, select **Data Extraction**.

The **Summary** page is displayed with a list of data extraction definitions.

2. Select **Sys ML Latest Balance Extract As Of Effective Date** by searching for it. Click to view details of this extract.

**Note**

You cannot modify the Name, Description, Grain, and Entity.

3. User will have the option to apply a filter on Management Ledger tables and Hierarchy tables.

**Note**

Note that selecting the Hierarchy parent will be available only for this out-of-the-box extract but not for other custom extracts.

4. Click **Select Attributes**. The following attributes are added in **Computed** section under **Available Attributes**.
  - Parent GL Account Code
  - Parent Business Unit Code
  - Parent Business Unit Description
  - Intercompany Identifier Description
  - Balance Update Start Time
  - Balance Update End Time

**Note**

Out-of-the-Box or custom attributes common across multiple dimension entities will not be displayed in the Select Attributes list. Related entities linked to the primary entity that do not have child attributes will not be displayed from the connector definition.

5. Click **Describe File**.
6. In **Specify Data file names**, enter the file name. This is a mandatory field.  
For example: sys\_ml\_latest\_bal\_as\_of\_effective\_date\_##LEDGER\_ID%.csv

**Note**

The file extension must be either .txt or .csv.

7. Select **Column delimiter** from the drop down list.  
For Example: Comma
8. Specify the **Text qualifier**.  
For Example: Double quotes can be used, prefixed, and suffixed with text.
9. Select the **file format**.  
For Example: Fixed Length or Delimited.
10. Select the **Record delimiter**.  
For Example: Unix
11. Toggle the **Header** button if you want a header to be displayed in the extracted file.  
This field is optional.

**Note**

The extracted file will show Result, Dimension, Integration, and Staging tables. Currently, Processing layer tables are not supported.

In case two physical entities contain the same logical name, the order of preference for the entity will be in the following order:

- 1 - Result
- 2 - Dimension
- 3 - Integration
- 4 - Staging

12. Toggle the **Generate a control file** button if you want to generate a control file. The control file provides verification/validation information for use with extracted data files.

This field is optional.

In the **Specify control file name** field, enter the file name. This is a mandatory field. The file extension must be either .txt or .csv.

The parameters you entered for **Specify Data file names** are copied to the Control file properties. You can modify based on your requirements. By default, the name is added as **< Specify Data file names >\_control.csv/.txt**. For more details on fields such as Select file format, Select Column delimiter, Select Record delimiter, and Specify Text qualifier, see the above step.

To add the controls, click Add button.

- Add the control name in the text box.
- Select the aggregation type from the dropdown. The supported options are Count, Avg, Sum, Min, and Max.
- Select the attribute from the drop-down. The Attribute field is disabled when the aggregation type is selected as Count.

You can add multiple controls to the file by clicking on Add button.

The Control file is available in the Archived Extract file.

**Note**

The following are the behavior of the Control file in this release:

- There is no validations performed while generating a control file.
- Header will not be generated in case of control file during data extraction and you will not have an option to add the header.

13. Click **Save**.

The **Sys ML Latest Balance Extract As Of Effective Date** definition is updated.

14. For this seeded connector, you must create a pipeline to execute. You must pass a value for LEDGER\_ID during execution.

**Note**

For more information on Connectors, see the [Connectors](#) section.

**Note**

The attributes common across Management Ledger Period Balance And Movement, and Management Ledger COA Segment Combination COA Segments entities are exposed for extraction. You can select and de-select the common attributes across these entities.

**Note**

Incremental data extraction is supported for Management Ledger Latest Balance As Of Effective Date Connector.

## 23.10 Extraction of Data for Reconciliation Difference

To add a Data Extraction for Reconciliation, follow these steps:

1. From the **AFCS Home** page, select **Data Extraction**.

The **Summary** page is displayed with a list of data extraction definitions.

2. Click **Add**.

The **Specify Details** window appears.

3. Enter the **Name** for the Data Extraction.

For Example: Extract Reconciliation Difference.

4. Enter the **Description** of the Data Extraction.

This field is optional.

5. Select the **Grain** from the drop-down list.

For Example: Other.

6. Select the **Entity** from the drop-down list.

For Example: Reconciliation Difference

7. Enter the required filter expression for the Data Extraction. In addition, you can also add Parameters.

This field is optional.

For Example: [Reconciliation Difference].[Reconciliation Rule Surrogate Key] is equal to numeric identifier.

**Note**

For filtering data on Reconciliation rules, you can specify member values for specific Reconciliation Rule Surrogate Key attributes.

- Click **Validate** to verify the correctness of the SQL Expression and click **OK**.

The filter expression is displayed in the **Expression** text box.

- Navigate to the **Select Attributes** page.

The **Attributes list** displays the list of attributes that can be associated with the Data Extraction. The attribute list shows the combined attributes for all the tables selected.

- Select the attributes and click **OK**.

Select or unselect the attributes by clicking the respective icons. You can also drag and drop to rearrange the attributes in the **Selected Attributes** section.

**Note**

You can select a maximum of 998 attributes.

**Note**

You can click Edit icon and rename the header attribute name, if required.

**Note**

Post upgrade, attributes of existing result entity extract connectors must be de-selected and selected again to auto rename attributes and validation on duplicate columns in selected attributes.

**Note**

For new connectors, attributes will be automatically renamed when selected. Auto-renaming of attributes to its corresponding dimension code attributes in the user interface is done only for Result table surrogate keys.

- Navigate to the **Describe File** page.

- In **Specify Data file names**, enter the file name. This is a mandatory field.

For example: test\_file\_data.txt

**Note**

The file extension must be either .txt or .csv.

- Select **Column delimiter** from the drop down list.

For Example: Comma

- Specify the **Text qualifier**.

For Example: Double quotes can be used, prefixed, and suffixed with text.

- Select the **file format**.

For Example: Fixed Length or Delimited.

**16. Select the Record delimiter.**

For Example: Unix

**17. Toggle the Header button if you want a header to be displayed in the extracted file.**

This field is optional.

**Note**

The extracted file will show Result, Dimension, Integration, and Staging tables. Currently, Processing layer tables are not supported.

In case two physical entities contain the same logical name, the order of preference for the entity will be in the following order:

- 1 - Result
- 2 - Dimension
- 3 - Integration
- 4 - Staging

**18. Toggle the Generate a control file button if you want to generate a control file. The control file provides verification/validation information for use with extracted data files.**

This field is optional.

In the **Specify control file name** field, enter the file name. This is a mandatory field. The file extension must be either .txt or .csv.

The parameters you entered for **Specify Data file names** are copied to the Control file properties. You can modify based on your requirements. By default, the name is added as **< Specify Data file names >\_control.csv/.txt**. For more details on fields such as Select file format, Select Column delimiter, Select Record delimiter, and Specify Text qualifier, see the above step.

To add the controls, click Add button.

- Add the control name in the text box.
- Select the aggregation type from the dropdown. The supported options are Count, Avg, Sum, Min, and Max.
- Select the attribute from the drop-down. The Attribute field is disabled when the aggregation type is selected as Count. The numerical attributes supports the aggregation type Sum, Average, Min, and Max. The Date attribute supports the aggregation type Min and Max only.

You can add multiple controls to the file by clicking on Add button.

The Control file is available in the Archived Extract file.

**Note**

The following are the behavior of the Control file in this release:

- There is no validations performed while generating a control file.
- Header will not be generated in case of control file during data extraction and you will not have an option to add the header.

19. Click **Save**.

The Data Extraction Definition is created.

**Note**

The maximum extracted archive file size must be less than or equal to 7.5 GB.

20. After the Data Extraction is saved, the PMF process needs to be configured and executed. For more details, see [Executing Connector using Process Modelling Framework](#)  
The Data Extraction file is created.
21. Download the file from the File Operations screen. For more details, see [File Operations](#).

# 24

## Obtaining Support for Your Service

Raise a Service Request (SR) in [My Oracle Support \(MOS\)](#) for queries related to Accounting Foundation Cloud Service.

# 25

## Key Terms and Concepts

This section explains several key terms and concepts.

### 25.1 Adjustment Entry

An entry passed in the Product Processor (PP) to reconcile it with the associated GL for the amount equivalent to the difference and an entry in the Contra GL Account with the opposite sign for the same amount.

### 25.2 Adjustment Entry Floor

If the difference between Source and Target is less than the Adjustment Entry Floor specified in the definition, the calculated difference is not eligible for adjustment, and the entry will not be logged in the Adjustment Entry Table.

### 25.3 Attributed Dimension

A dimension whose members can have other properties or qualifiers known as Dimension Attributes.

### 25.4 Data set

A dimension used for segregating data into different sets according to its use or its source. For example, to separate actuals data, budget data, and encumbrances data. Other uses include separating test data from production data and creating separate data sets for What-if Analysis.

### 25.5 Dimension

A structure that can be used to categorize business data. A dimension contains members; it can be hierarchical (you can organize the members into one or more hierarchies), or non-hierarchical.

### 25.6 Dimension Attributes

A property or qualifier that further describes a dimension member. An attribute can be a date, a number, or a character string. For example, the Geography dimension can have an attribute - Population, that designates how many people live in that area. Each member of the Geography dimension, therefore, has an associated Population.

### 25.7 Hierarchy

A structure of dimension members organized by parent-child relationships.

## 25.8 Global Threshold

Global Threshold is applied at an execution level where all the reconciliation differences for execution are added and checked across the absolute sum of source balance.

## 25.9 Inherit to Child

This feature is used to find child legal entities under the hierarchy node of a Legal Entity that is selected at the definition level. If used while defining the GL Reconciliation rule, all child nodes will participate in the reconciliation process.

## 25.10 Reconciliation

Reconciliation is the process of comparing information from one data source to another. An Account Reconciliation is for a specific period. Reconciliations consist of account balances (obtained from the Source System for the period) and account properties.

## 25.11 Reconciliation Difference

Reconciliation difference is the difference in the balance between the Source and the Target.

## 25.12 Threshold

A tolerance level you must set in terms of either the maximum difference allowed in any single Product Processor and its corresponding GL or the maximum number of Product Processors having differences in the GL Reconciliation.

## 25.13 Positive Threshold

These values are used to identify the breach types categorized as: Negative Percentage Threshold (NPT), Positive Percentage Threshold (PPT), Negative Absolute Threshold (NAT), Positive Absolute Threshold (PAT), and Not Breached (NB). The Breach Type is identified at run time during the reconciliation process, and Audit Trail entries are posted with this information.

## 25.14 Negative Threshold

These values are used to identify the breach types categorized as: Negative Percentage Threshold (NPT), Positive Percentage Threshold (PPT), Negative Absolute Threshold (NAT), Positive Absolute Threshold (PAT), and Not Breached (NB). The Breach Type is identified at runtime during the reconciliation process, and Audit Trail entries are posted with this information.

## 25.15 Threshold Breached Type

The different types of threshold breaches are listed here.

- PAT - Positive Absolute Threshold
- NAT - Negative Absolute Threshold

- PPT - Positive Percentage Threshold
- NPT - Negative Percentage Threshold
- G - Global
- NB - Not breached

## 25.16 General Ledger to Product Processor

General Ledger to Product Processor Reconciliation identifies the difference between GL system and Product Processor data. It nullifies the difference by posting the adjustment entries up to the amount of difference.

## 25.17 General Ledger to Product Management Ledger

In General Ledger to Management Ledger (GL to ML) reconciliation, the difference between two sources of the Ledger for the same Legal Entity and the Consolidation Type is identified. This difference is identified at the granularity of the GL code for the selected hierarchy, the mandatory dimensions, and the selected optional dimensions. Adjustments are not passed in General Ledger to Management Ledger reconciliation.

## 25.18 Consolidation Type

Two consolidation types are supported:

- Solo
- Consolidated

### 25.18.1 Solo

When a legal entity is selected with consolidation type as Solo, all the exposures of that particular legal entity are selected for processing. Manual reconciliation definition can process solo legal entity data.

### 25.18.2 Consolidated

When a parent legal entity is selected as Consolidated, all the exposures of that legal entity and exposure of each level (or levels) of descendant child legal entities (without intra-group exposures) are selected for processing. In intra-group exposures, the counterparty is a child descendant of any level. For an intra-group scenario (where the GL Structure has specific intra-group GL Code in addition to regular GL Codes), intra GL Codes are considered only from the GL side for processing. Non-Intra is a scenario where no GL Codes are present for reconciliation definition.

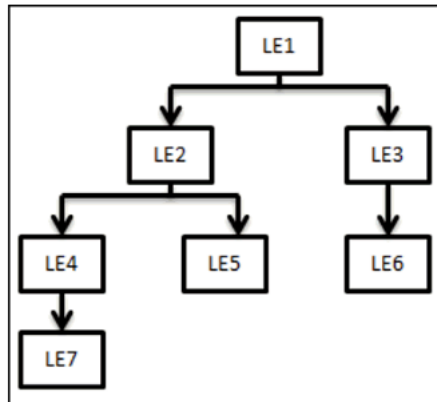
**Figure 25-1 Consolidated Process Flow**

In this case, LE 1 is the parent legal entity, LE2 and LE3 are the immediate child legal entities of LE1. Similarly, LE4 and LE5 are immediate child legal entities of LE2, but second-level descendant legal entities of LE1.

If you select LE2 (parent) for consolidated treatment, then exposure to LE 4, LE 5, and LE7 are considered as intra-group exposures.

**Note**

The application only aggregates data on the PP side for a **Consolidation** reconciliation type; such aggregation is only to reconcile data and does not consider minority or majority holdings.

Intra-group exposures are identified by the customer reference ID in the Product Processor. For LE2, if the customer reference ID is LE4, LE5, and LE7, then these are considered as intra-group exposures. Exposures to LE3 or LE6 are not considered as intra-group exposures as they are not the child descendants of LE 2. If you select LE7 for consolidated treatment, then no exposures are considered as intra-group exposure as LE7 has no child legal entity.

**Note**

Intra-group exposures are identified by the customer reference ID in the PP Table.

### 25.18.3 Inherit to Child

This feature is used to find child legal entities under the hierarchy node of a Legal Entity that is selected at the definition level. If used when defining the GL Reconciliation rule, all child nodes will participate in the Reconciliation Process.

### 25.18.4 Manual Reconciliation Definition

In manual reconciliation definition, user input is sought on the GL side and PP side to determine the course of reconciliation. This is applicable to both GL level and map level reconciliation. In GL level reconciliation, unique GL codes are identified from the GL code mapping. At the map level, GL codes do not form a part of the reconciliation definition. A

manual reconciliation definition can be used for a solo or consolidated legal entity. The reconciliation definition for a consolidated GL, having an intra-group GL structure, is computed from GL Data and not from PP Data. Therefore, any account present in the PP but unavailable in GL is not captured in the reconciliation definition.

## 25.18.5 GL Level Reconciliation

In GL level reconciliation, the difference between GL system and Product Processors Systems at each reconciliation dimension node level within a GL Code is identified. For manual reconciliation definition, unique GL codes are identified from the GL side. If it is at the solo level, exposures originating in the legal entity are selected. If it is at the consolidated level, exposures originating in the selected legal entity and its Child Entities (with or without intra-group exposures depending on GL Structure) are selected.

The adjustment entry allocation depends on the reconciliation type selected. In GL level reconciliation, after a definition is executed, the differences that emerge as a part of the reconciliation definition (GL–PP level reconciliation) are reported in the Adjustment Entry Table. This table shows all the entries of an executed map that requires adjustment. The difference in amount can either be posted to Product Processors or an external table. For more information on the external table, see the Data Requirement section.

### Note

In GL level reconciliation, the adjustment allocation is always automatic, that is, you do not have the option of editing the allocation ratio.

## 25.18.6 Map Level Reconciliation

In map level reconciliation, the difference between GL Data and PP Data at each reconciliation dimension node level across all PPs is identified. Unlike GL level reconciliation, map level reconciliation is computed at an aggregate level of the reconciliation definition; by ignoring the GL code and by considering reconciliation dimensions. Map level reconciliation is applied at the legal entity level - either solo or consolidated. If it is at the solo level, then exposures originating in a particular legal entity are selected. If it is at the consolidated level, then exposures originating in the selected legal entity and its child entities (excluding intra-group exposure depending on GL structure) are selected.

### Note

In a map level reconciliation, adequate filters for the PP data must be selected to ensure that the actual data selected on both sides are the same.

You need to create GL hierarchy data with one additional node value as 'MSG'. You can provide this Child code as 'MSG' and the name of the node can be set to 'Missing'. Add this node under the root node of the General Ledger Hierarchy which is sourced in the application.

The adjustment entry allocation depends on the reconciliation type selected. In map level reconciliation, after a definition has been executed the differences that emerge as a part of the reconciliation (General Ledger–Product Processor Level Reconciliation) are reported in the Adjustment Entry Table. This table shows all the entries of an executed map that requires

adjustment. The difference in amount can either be posted to Product Processors or an external table. The adjustment allocation can be either automatic or manual.

# Frequently Asked Questions

You can refer to the Frequently Asked Questions, which is developed with the interest to help you resolve some of the AFCS Installation and Configuration Issues. This intends to share the knowledge of problem resolution to a few of the Known Issues. This is not an official support document and just attempts to share the knowledge of problem resolution to a few of the Known Issues.

1. What happens when users tries to log in during a maintenance period?

When the instance is under maintenance, a “Maintenance Page” is displayed.

2. What happens for the users that are logged in?

If users are already logged in, all further actions are blocked. On refresh, users are directed to the Maintenance Page.

3. Can APIs be invoked during maintenance period?

No. The API requests are blocked.

4. What happens to ongoing batches?

Batches will continue, however, it is recommended to ensure all processes are completed before maintenance begins.

# Glossary

# Index