

Oracle® MICROS Compact Workstation 3 Series Setup Guide



E92395-19
February 2023



Copyright © 2018, 2023, Oracle and/or its affiliates.

This software and related documentation are provided under a license agreement containing restrictions on use and disclosure and are protected by intellectual property laws. Except as expressly permitted in your license agreement or allowed by law, you may not use, copy, reproduce, translate, broadcast, modify, license, transmit, distribute, exhibit, perform, publish, or display any part, in any form, or by any means. Reverse engineering, disassembly, or decompilation of this software, unless required by law for interoperability, is prohibited.

The information contained herein is subject to change without notice and is not warranted to be error-free. If you find any errors, please report them to us in writing.

If this is software, software documentation, data (as defined in the Federal Acquisition Regulation), or related documentation that is delivered to the U.S. Government or anyone licensing it on behalf of the U.S. Government, then the following notice is applicable:

U.S. GOVERNMENT END USERS: Oracle programs (including any operating system, integrated software, any programs embedded, installed, or activated on delivered hardware, and modifications of such programs) and Oracle computer documentation or other Oracle data delivered to or accessed by U.S. Government end users are "commercial computer software," "commercial computer software documentation," or "limited rights data" pursuant to the applicable Federal Acquisition Regulation and agency-specific supplemental regulations. As such, the use, reproduction, duplication, release, display, disclosure, modification, preparation of derivative works, and/or adaptation of i) Oracle programs (including any operating system, integrated software, any programs embedded, installed, or activated on delivered hardware, and modifications of such programs), ii) Oracle computer documentation and/or iii) other Oracle data, is subject to the rights and limitations specified in the license contained in the applicable contract. The terms governing the U.S. Government's use of Oracle cloud services are defined by the applicable contract for such services. No other rights are granted to the U.S. Government.

This software or hardware is developed for general use in a variety of information management applications. It is not developed or intended for use in any inherently dangerous applications, including applications that may create a risk of personal injury. If you use this software or hardware in dangerous applications, then you shall be responsible to take all appropriate fail-safe, backup, redundancy, and other measures to ensure its safe use. Oracle Corporation and its affiliates disclaim any liability for any damages caused by use of this software or hardware in dangerous applications.

Oracle®, Java, and MySQL are registered trademarks of Oracle and/or its affiliates. Other names may be trademarks of their respective owners.

Intel and Intel Inside are trademarks or registered trademarks of Intel Corporation. All SPARC trademarks are used under license and are trademarks or registered trademarks of SPARC International, Inc. AMD, Epyc, and the AMD logo are trademarks or registered trademarks of Advanced Micro Devices. UNIX is a registered trademark of The Open Group.

This software or hardware and documentation may provide access to or information about content, products, and services from third parties. Oracle Corporation and its affiliates are not responsible for and expressly disclaim all warranties of any kind with respect to third-party content, products, and services unless otherwise set forth in an applicable agreement between you and Oracle. Oracle Corporation and its affiliates will not be responsible for any loss, costs, or damages incurred due to your access to or use of third-party content, products, or services, except as set forth in an applicable agreement between you and Oracle.

Contents

1 Preface

Audience	1-1
Admonitions	1-1
Customer Support	1-2
Documentation	1-2
Revision History	1-2

2 The Compact Workstation 3 Series

Identifying Your Workstation	2-3
Primary I/O Ports	2-3
Flexible Stand	2-4
Basic Stand	2-5
Enclosure for Battery	2-6

3 Workstation Setup

Initial Workstation Startup – Microsoft Windows 10	3-1
Initial Workstation Startup – Oracle Linux for MICROS	3-1
Mounting the Compact Workstation 3 Series on the Flexible Stand	3-1
Mounting the Compact Workstation 3 Series on the Basic Stand	3-4
Securing the Flexible Stand to a Counter	3-6
Securing the Basic Stand to a Counter	3-7
Securing the Workstation to the Wall Mount	3-7
Assembling the Enclosure for the Battery	3-12
Mounting the Enclosure for Battery on the Flexible Stand	3-13
Mounting the Enclosure for Battery on the Basic Stand	3-14
Installing the Oracle MICROS Powered Serial Port and Pole Display Expansion Module	3-15
Installing the Biometric Fingerprint Module	3-17
Securing the Workstation to a VESA Mount	3-18

4	Technical Specifications	
	Power Considerations for Peripheral Devices	4-2
5	Software Components	
	Microsoft Windows 10 IoT Enterprise Operating System	5-1
	Oracle Linux for MICROS Operating System	5-1
	Oracle Linux for MICROS Commands	5-2
	Compact Workstation 3 Series Platform	5-3
6	Workstation Accessibility Features	
7	Diagnostics Utility	
	Starting the Compact Workstation 3 Series Diagnostics Utility	7-1
	Viewing System Information	7-1
	Testing the LCD Display	7-2
	Testing the Integrated Magnetic Stripe Reader	7-2
	Testing the Encrypted Magnetic Stripe Reader	7-3
	Testing the Customer Display	7-3
	Testing the Cash Drawers	7-3
	Performing an RS232 Loopback Test	7-3
	Testing an RS232 Printer	7-3
	Performing an IDN Loopback Test	7-4
	Testing an IDN Printer	7-4
	Viewing Diagnostics Reports for Devices on COM Ports	7-4
	Viewing Hardware Controls	7-4
	Viewing Diagnostics Reports for I2C Devices	7-5
	Testing the Fingerprint Reader	7-5
	Battery Monitor	7-5
8	BIOS Configuration	
	Starting the BIOS Configuration Utility	8-1
	Viewing System Information	8-1
	Configuring System Security Settings	8-1
	Configuring the Boot Priority for Devices	8-2
	Exiting the BIOS Configuration Utility	8-3
	Special Configuration Settings	8-3

9 Equipment Dimensions

Dimensions – Compact Workstation 310 with Flexible Stand	9-1
Dimensions – Compact Workstation 310 with Basic Stand	9-2

10 I/O Panel Connectors and System Diagrams

I/O Panel Connectors	10-1
IDN RS422/232	10-1
RJ45	10-1
Series 2 Cash Drawer	10-2
USB Ports	10-3
System Block Diagrams	10-3
Compact Workstation 310 System Block Diagram	10-3

11 Troubleshooting

Basic Troubleshooting	11-1
System Recovery	11-1
Performing a System Recovery for Microsoft Windows 10	11-2
Performing a Factory Reset from BIOS (Microsoft Windows)	11-3
Performing a Factory Reset from BIOS (Oracle Linux for MICROS)	11-4
Performing a Factory Reset using the Recovery Button	11-4

12 Safety and Handling

Safety Agency Compliance Statements	12-1
Safety Precautions	12-1
Modifications to Equipment	12-1
Placement of an Oracle Product	12-2
SELV Compliance	12-2
Power Cord Connection	12-2
Battery Warning	12-3
System Unit Cover	12-3
International Compliance Information	12-3
Care and Handling	12-4
Equipment Placement	12-4
Electromagnetic Interference	12-4
Cleaning	12-4

1

Preface

Audience

This document is intended for those who will be setting up, installing, and operating the Oracle MICROS Compact Workstation 3 Series. It is not specific to a particular software application.

Admonitions

Unless specified, the information in this document applies to each configuration of the Compact Workstation 310.

The following symbols may appear in this document:



Caution: There is a risk of personal injury and equipment damage. Follow the instructions.



Caution: Hot surface. Avoid contact. Surfaces are hot and may cause personal injury if touched.



Caution: Hazardous voltages are present. To reduce the risk of electric shock and danger to personal health, follow the instructions.

Depending on the type of power switch your device has, one of the following symbols may be used:

On: Applies AC power to the system.



Off: Removes AC power from the system.



On: The On/Standby switch is in the standby position.



Customer Support

To contact Oracle Customer Support, access My Oracle Support at the following URL:
<https://support.oracle.com>.

When contacting Customer Support, please provide the following:

- Product version and program/module name
- Functional and technical description of the problem (include business impact)
- Detailed step-by-step instructions to re-create
- Exact error message received
- Screenshots of each step you take

Documentation

Oracle Hospitality product documentation is available on the Oracle Help Center at
<http://docs.oracle.com/en/industries/hospitality/>.

Revision History

Date	Description of Change
January 2018	<ul style="list-style-type: none">• Initial publication.
March 2018	<ul style="list-style-type: none">• Changed image scaling.
August 2018	<ul style="list-style-type: none">• Added link to the video for assembling and mounting the enclosure for battery.• Updated image to clarify that the workstation does not include a camera.
November 2018	<ul style="list-style-type: none">• Added Compact Workstation 310R port plug information.
April 2019	<ul style="list-style-type: none">• Miscellaneous improvements.
June 2019	<ul style="list-style-type: none">• Added wall mounting information.
March 2020	<ul style="list-style-type: none">• Added Oracle Linux for MICROS information.

Date	Description of Change
May 2020	<ul style="list-style-type: none"><li data-bbox="876 262 1377 325">• Added international compliance information.
August 2022	<ul style="list-style-type: none"><li data-bbox="876 325 1377 367">• Miscellaneous improvements.
September 2022	<ul style="list-style-type: none"><li data-bbox="876 367 1377 430">• Updated model numbers in selected sections.
February 2022	<ul style="list-style-type: none"><li data-bbox="876 430 1377 491">• Removed NIST label references.

2

The Compact Workstation 3 Series

The Oracle MICROS Compact Workstation 3 Series consists of three configurations: the 310, 310R, and the 320R.

- The Oracle MICROS Compact Workstation 310 features an Intel Atom processor and runs the Microsoft Windows 10 IoT Enterprise operating system.
- The Oracle MICROS Compact Workstation 310R features an Intel Atom processor and runs the Microsoft Windows 10 IoT Enterprise operating system. The 310R includes a high-brightness LCD and is IP45 rated.
- The Oracle MICROS Compact Workstation 320R features an Intel Atom processor and runs the Microsoft Windows 10 IoT Enterprise operating system. The 320R supports SATA storage and includes 8GB of RAM.

Each workstation is a Point of Sale (POS) terminal featuring a 10.1 inch widescreen 1280x800 display with a projected capacitive touch screen.

Refer to the [Technical Specifications](#) section for detailed information.

Oracle MICROS Compact Workstation 3 Series Basic Features

Figure 2-1 Compact Workstation 3 Series Basic Features



Table 2-1 Compact Workstation 3 Series Basic Features

Feature
1. Ambient Light Sensor
2. Magnetic Card Reader
3. Power Button
4. Customer Display
5. Fingerprint Reader (optional)
6. I/O Connector Panel (located under cover)

Powering On and Off

To power on, push and quickly release the power button. The display powers on after a few seconds. To power off for extended storage, use the Shut Down function provided in the operating system software.

Identifying Your Workstation

To identify your configuration of the Oracle MICROS Compact Workstation 3 Series, use the following indicators:

- The power button:
 - For the 310, the raised edge around the power button is black.
 - For the 310R, the raised edge around the power button is blue.
 - **Note:** Both the 310 and the 310R feature blue LEDs when powered on.
- The label on the back of the workstation display:
 - For the 310, the Model reads **MICROS Compact Workstation 3 | 310**.
 - For the 310R, the Model reads **MICROS Compact Workstation 3 | 310R**.

Primary I/O Ports

Figure 2-2 Primary I/O Panel of the Oracle MICROS Compact Workstation 3 Series

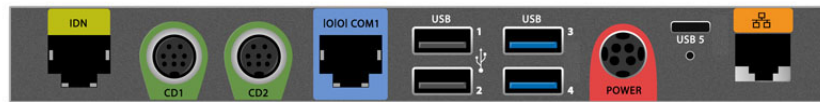

Table 2-2 Oracle MICROS Compact Workstation 3 Series Primary I/O Panel Ports

Port	Description
IDN	1x IDN (RS422/RS232) – RJ45
CD1/CD2	2x 8-pin miniDIN (12V) Series 2 Cash Drawer connectors
IOIOI COM1	1x RS232 – RJ45
USB 1/2	2x USB 2.0
USB 3/4	2x USB
Power	Accepts external power adapter with 15V@5.33A (80W), 80~264VAC and external battery power pack
USB 5	1x USB (15V @ 3A MAX, switchable to 5V via BIOS option)
Ethernet Port	GbE (10/100/1G)

 **Note:**

The Oracle MICROS Compact Workstation 310R is IP45 rated when you seal all unused ports using the provided rubber plugs.

Figure 2-3 Plugs for Unused Ports on the Oracle MICROS Compact Workstation 310R

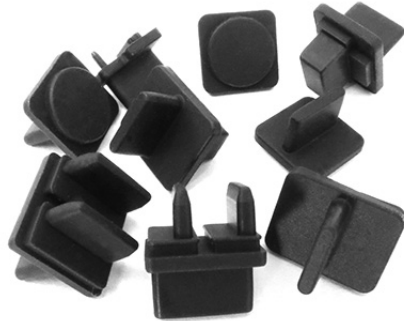

Flexible Stand

The Flexible Stand provides a solid base for mounting the Compact Workstation 3 Series, a wide range of positioning for optimal viewing angle, and enhanced cable management.

Figure 2-4 The Oracle MICROS Flexible Stand

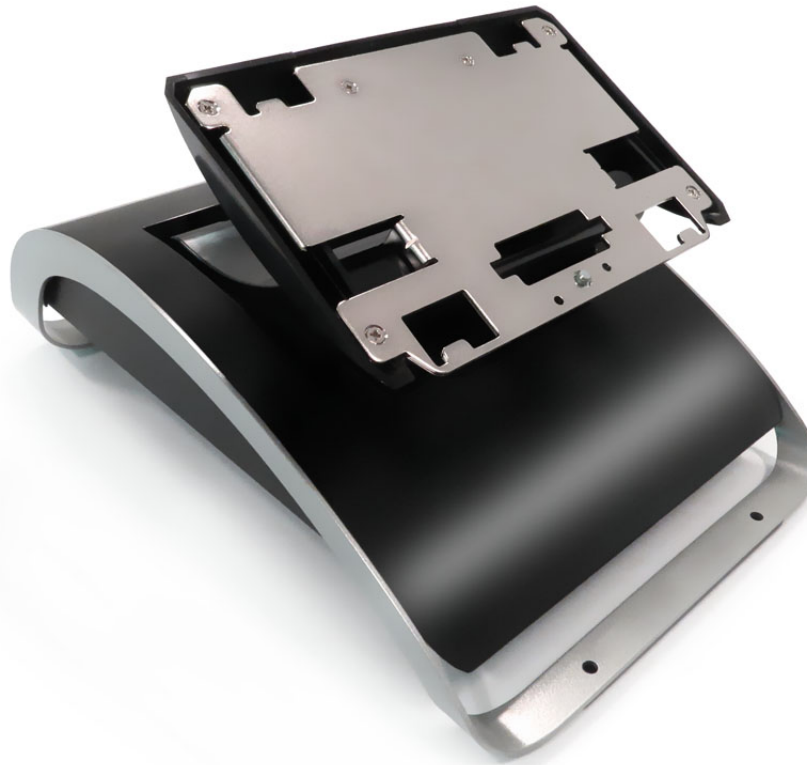

Basic Stand

The Basic Stand (optional) provides a sturdy, lightweight base for mounting the Compact Workstation # Series at a 20-degree fixed angle.

Figure 2-5 The Oracle MICROS Basic Stand



Figure 2-6 The Oracle MICROS Basic Stand with Compact Workstation 310



Enclosure for Battery

The MICROS Enclosure for Battery (optional) enables you to run the Compact Workstation 310 using battery power.

Enclosure for Battery Basic Features

Figure 2-7 The Enclosure for Battery



Table 2-3 Enclosure for Battery Basic Features

- | |
|----------------------------|
| 1. Power MiniDIN Connector |
| 2. DC Power Input |
| 3. Cover Screws (2x) |
| 4. Stand Thumbscrew |
| 5. Battery Terminals |
| 6. Mounting Tabs (2x) |

3

Workstation Setup

This section contains instructions for assembling, setting up, and securing the Compact Workstation 3 Series.

Initial Workstation Startup – Microsoft Windows 10

The first time you start your workstation you must complete the Microsoft Windows 10 operating system setup.

1. Complete the Microsoft Windows setup by following the prompts. Consult your network administrator for help with configuring network and system settings.
2. Ensure your workstation is connected to a secure network.
3. Install the Client Application Loader (CAL) by double-tapping the **CALClient Installer** icon and following the prompts. Upon successful completion, the workstation is connected to your application's CAL server. For more information, refer to the latest version of the *Oracle Hospitality Symphony Client Deployment Guide* on the Oracle Help Center at <https://docs.oracle.com/en/industries/food-beverage/>.

Initial Workstation Startup – Oracle Linux for MICROS

The first time you start your workstation you must complete the Oracle Linux for MICROS operating system setup.

1. Follow the prompts to complete the Oracle Linux for MICROS setup.
 - a. Set language, keyboard, and time zone.
 - b. Enter and confirm a Support user password. Follow the password length and complexity requirements displayed on-screen.
 - c. Configure the network settings.
 - d. Enter the CAL server address to install your Oracle MICROS POS software. For more information, refer to the latest version of the *Oracle Hospitality Symphony Client Deployment Guide* on the Oracle Help Center at <https://docs.oracle.com/en/industries/food-beverage/>.

Mounting the Compact Workstation 3 Series on the Flexible Stand

1. Remove the I/O panel cover by sliding it off the workstation.

Figure 3-1 Removing the Workstation I/O Panel Cover

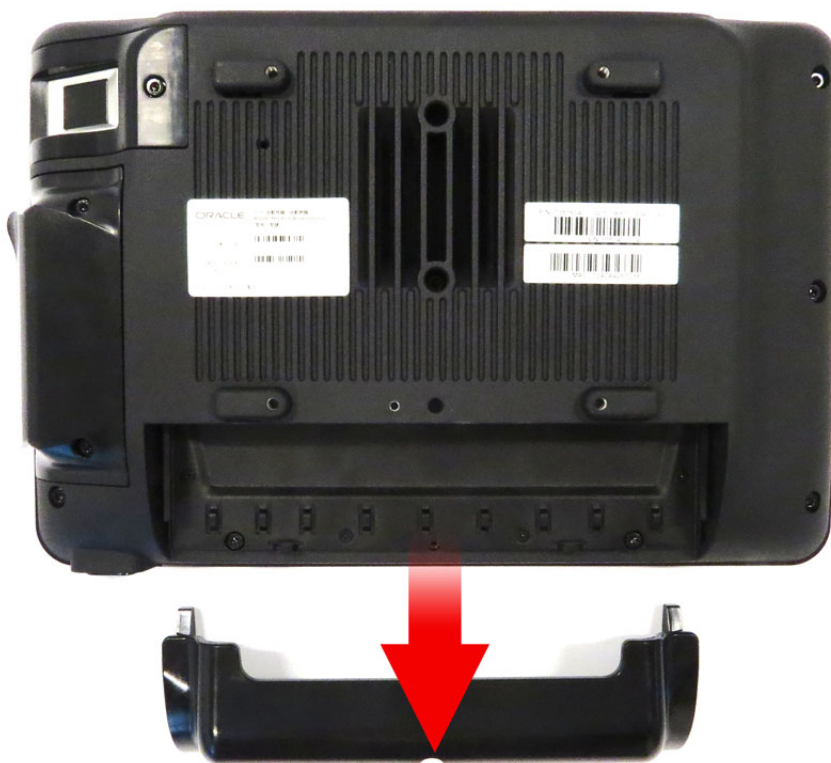

2. Place the Flexible Stand upright on a flat surface. Note the location of the four mounting tabs and the quick release pin, as shown in the following image.

Figure 3-2 The Flexible Stand Workstation Mounting Tabs

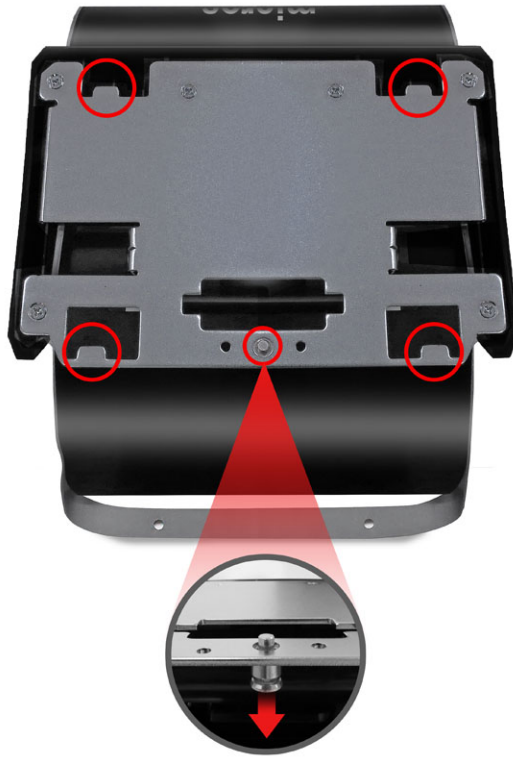

3. Place the workstation on the stand by inserting the four mounting nubs into the mounting tabs on the stand.

Figure 3-3 Mounting the Compact Workstation 3 Series on the Flexible Stand



4. Pull the workstation toward you until you hear the quick release pin click. If it is not depressed, you must pull the workstation toward you until it clicks in place.

Figure 3-4 Location of the Compact Workstation 3 Series Security Screw



5. For added stability and security, install the security screw.
6. Connect the required cables.

Mounting the Compact Workstation 3 Series on the Basic Stand

1. Place the Basic Stand upright on a flat surface.
2. Remove the workstation I/O panel cover.

Figure 3-5 Removing the Compact Workstation 3 Series I/O Panel Cover

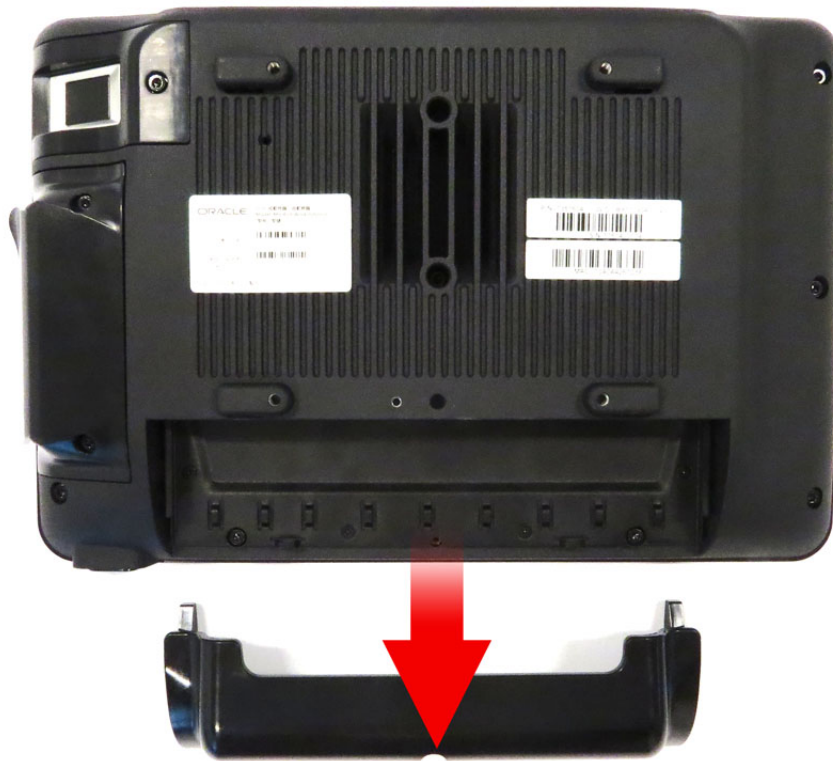

3. Place the flat side of the Basic Stand on the workstation by aligning the open slots over the four workstation mounting nubs.
4. Slide the Basic Stand up to join the stand with the workstation.

Figure 3-6 Attaching the Compact Workstation 3 Series to the Basic Stand

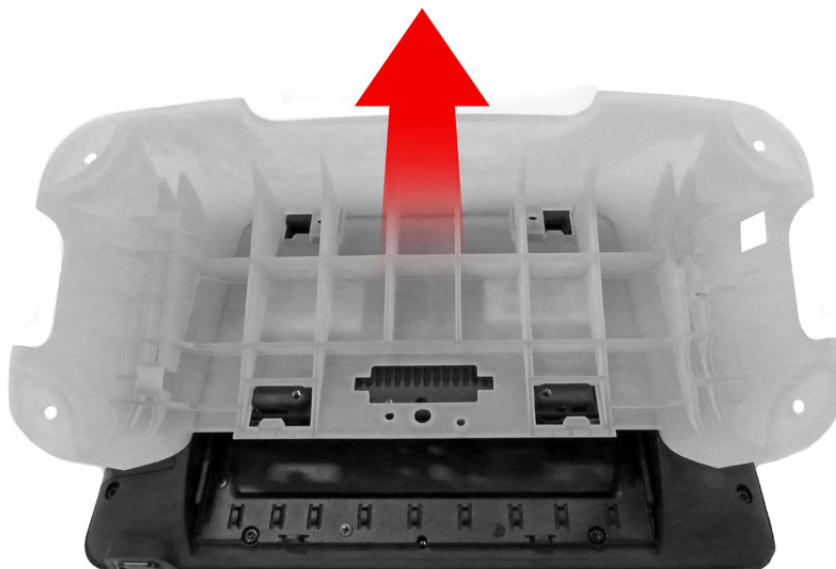

5. Secure the stand to the workstation using the provided security screw and hex wrench.

Figure 3-7 Attaching the Compact Workstation 3 Series to the Basic Stand

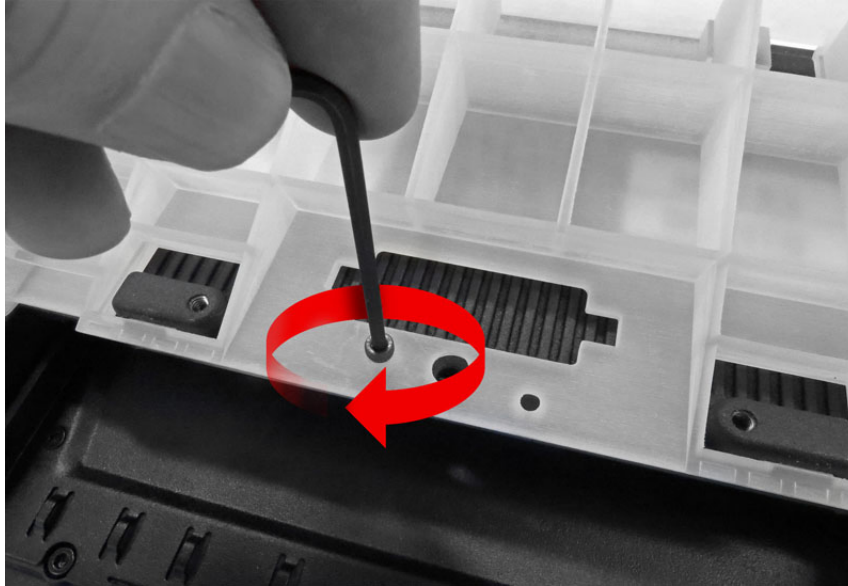

6. Connect the required cables, and then re-attach the I/O panel cover.

Securing the Flexible Stand to a Counter

The Flexible Stand is a mounting option for the Compact Workstation 310. When using this option, ensure that the stand is properly secured to a counter.

Note: The mounting screws are not provided. Ensure that you are using screws that meet the needs of the installation. The stand mounting hole diameter is ~4.9mm (0.193" = ~3/16") and will accept up to a #10 or M4 screw. The screw length should be a minimum of one inch plus the thickness of the counter.

Note: If using a battery power option in conjunction with your workstation, you must first attach the battery enclosure to the stand before securing the stand to the counter.

Note: Connect and route all required cables before securing the stand to the counter.

1. Download the [Oracle MICROS Flexible Stand Mounting Template](#) and print it on legal size (8.5 x 14) paper. To ensure the template is properly printed, place a stand on the template and see if holes are aligned.
2. Place template on the counter surface. If multiple units will be installed on a counter surface, ensure all units are mounted at the proper distance from the edge of the counter.
3. Mark the four screw locations on the counter. If available, use a small punch tool to create small pilot hole (indentation).
4. Remove template, and then drill the holes.
 - a. Recommended metal surface hole diameter: 7/32" (5.5mm) drill bit size 7/32" (5.5mm).

- b. Recommended wood surface hole diameter: 15/64" (6mm) drill bit size 15/64" (6mm).
5. Install screws in the two counter holes that correspond with the back (logo side) of the stand. Leave at least .25 inches of each screw above the counter surface.
6. Place the Flexible Stand on the counter surface so that the two back screw grooves align with the screws installed on the counter.
7. Slide the stand until the screw holes on the front of the stand align with the holes in the counter surface.
8. Install/tighten all screws.

Securing the Basic Stand to a Counter

The Basic Stand is a mounting option for the Compact Workstation 310. When using this option, ensure that the stand is properly secured to a counter.

Note: If using a battery power option in conjunction with your workstation, you must first attach the battery enclosure to the stand before securing the stand to the counter.

1. Place the Basic Stand on the counter surface in the desired mounting position.
2. Using the stand screw holes as guides, mark the counter surface, and then use a drill to create the holes.
3. Secure the stand to the counter using mounting screws. The mounting screws are not provided. Ensure that you are using screws that meet the needs of the installation.
 - a. The stand mounting hole diameter is ~5.9mm (0.232" = ~15/64") and will accept up to a #12 or M5 screw.
 - b. The screw length should be a minimum of one inch plus the thickness of the counter.
 - c. Recommended metal surface hole diameter: 7/32" (5.5mm) drill bit size 7/32" (5.5mm). Recommended wood surface hole diameter: 15/64" (6mm) drill bit size 15/64" (6mm).

Securing the Workstation to the Wall Mount

The Compact Workstation 3 Series can be mounted on a wall using an optional wall mounting bracket.**

Note:

The following steps describe how to wall mount a Workstation 6 Series device. You can wall mount a Compact Workstation 3 Series device using the same procedure.

1. Install the wall mount:
 - a. Ensure that the metal bracket is levelled with the integrated spirit level.
 - b. Mark the positions of the holes at the four corners.
 - c. Create the holes by drilling into the wall.
 - d. Secure the metal bracket to the wall with four screws. The mounting screws are not provided. Ensure you are using the correct screws that meet the needs of the

installation, such as wood screws, dry wall screws, concrete screws, or masonry screws.

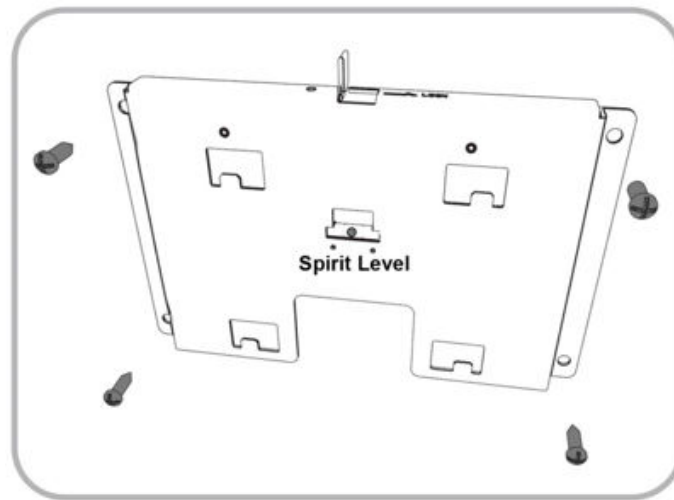

2. Insert the power connector to the back of the workstation. **Note:** The Compact Workstation 3 Series uses a different power connector type that connects to the power input port on the I/O panel.

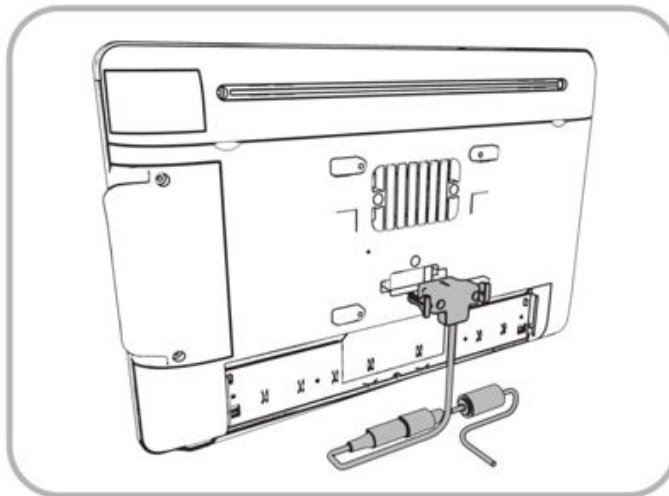

3. Align the back of the workstation display to the metal bracket, and then slide it down until it stops.

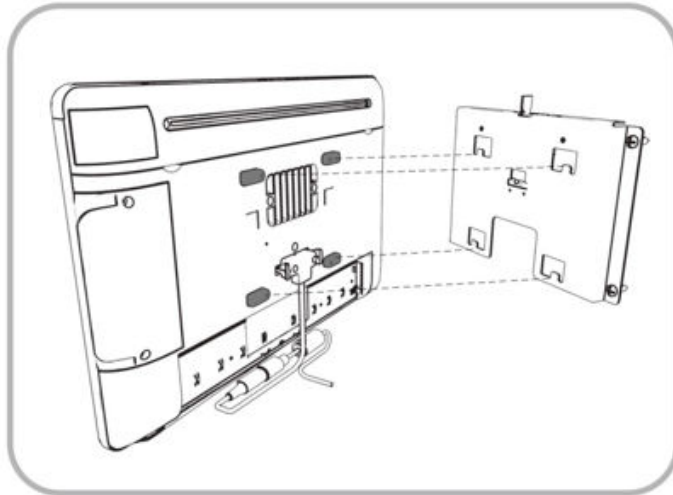

4. Connect the power supply connector to the power connector. **Note:** The Compact Workstation 3 Series uses a different power connector type that connects to the power input port on the I/O panel

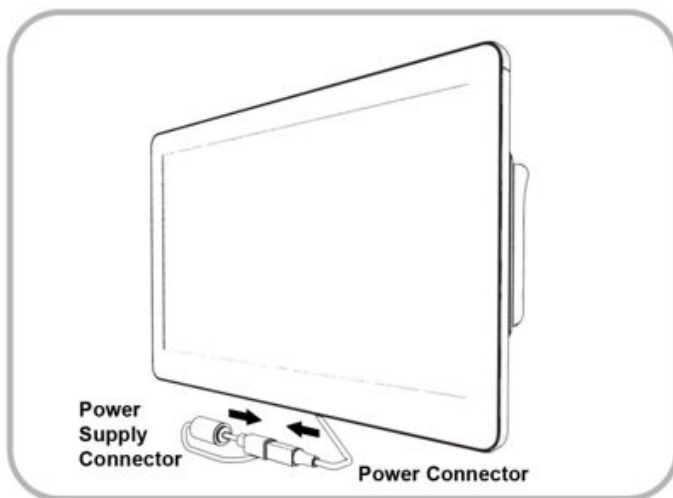

5. Slide the locking level to the right, and then tighten the screw with the hex key.

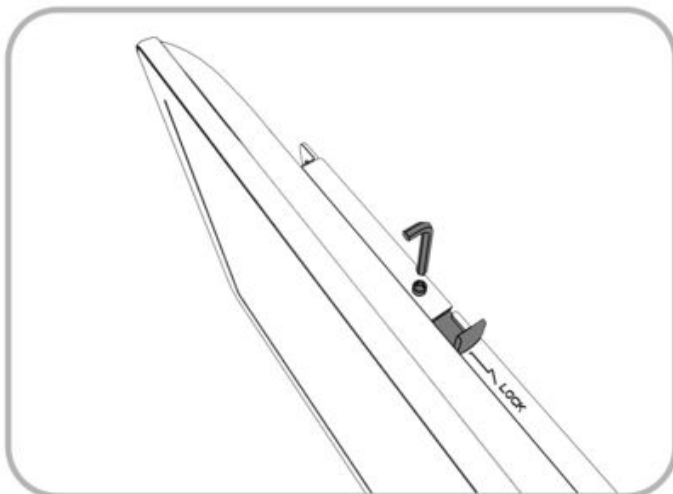

6. Conceal the cables with the cable casing.

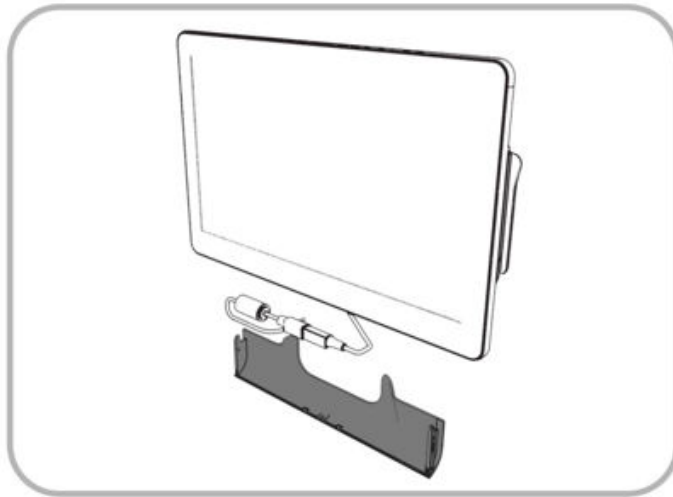

7. Secure the cable cover with the provided thumbscrew.

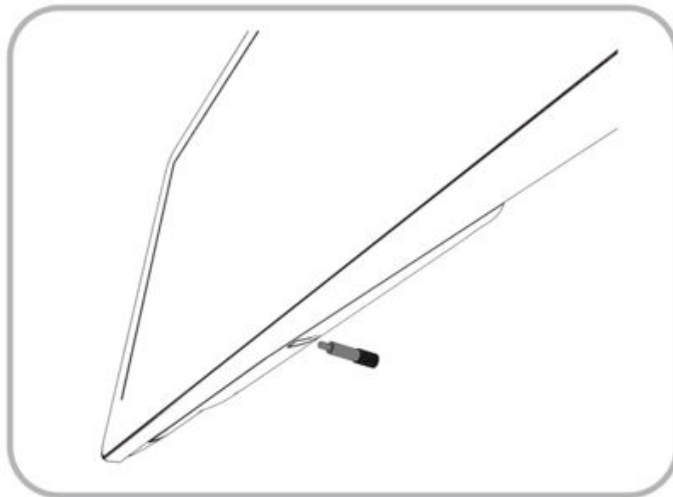

**Wall mount installation methods include:

- **Basic Wall Mounting** (shown in steps 1–7): The wall mount bracket is attached to the surface of the wall. Cables and power supplies are exposed and can be organized using cable ties and cable casing.
- **Recessed/In-Wall Cage with Cable Management and Concealed Power Supply Storage:** A portion of the wall is cut away and a recessed support cage provides a hidden area for cable organization and power supply storage. The wall mount bracket is then attached to the wall over the recessed area. Exposed cables can be organized using cable casing.

Figure 3-8 Example Wall-Mounted Workstation (Recessed/In-Wall Cage)



Assembling the Enclosure for the Battery

The Enclosure for Battery (optional) enables the Compact Workstation 310 to operate using battery power.

Initial setup:

1. Remove the enclosure cover by unscrewing the two captive screws using the hex wrench included with your workstation.

Figure 3-9 The Enclosure for Battery



2. Insert the battery into the enclosure by carefully aligning the battery power contacts (1) with the battery terminals. Gently press down on the battery to secure the connection.

Figure 3-10 Inserting the Battery in the Enclosure for Battery

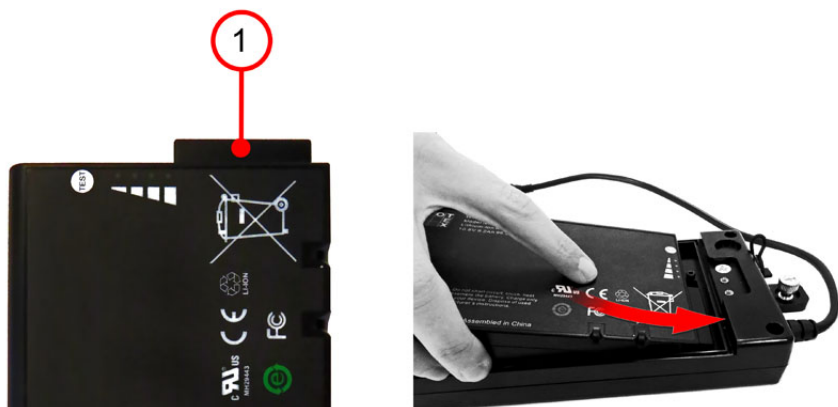

3. Replace the enclosure cover, and then tighten the two captive screws.

Mounting the Enclosure for Battery on the Flexible Stand

Mounting the Enclosure on the Flexible Stand

1. Place the stand upside down on a flat surface. Note the location of the two enclosure mounting slots (1).

Figure 3-11 The Flexible Stand Enclosure Mounting Slots



2. Place the enclosure into the recessed compartment, and then slide up to join the enclosure mounting tabs with the stand.

Figure 3-12 Installing the Enclosure

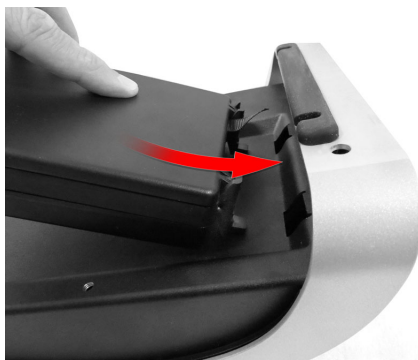

3. Tighten the stand thumbscrew (2) to secure the enclosure to the stand.

Figure 3-13 The Oracle MICROS Flexible Stand with the Enclosure



4. Connect the workstation Power Adapter (15V) to the DC power input, and then plug the Power Adapter into an outlet to charge the battery.

Mounting the Enclosure for Battery on the Basic Stand

Mounting the Enclosure on a Basic Stand

1. Place the stand and workstation upside down on a flat surface.

Figure 3-14 Bottom View of the Compact Workstation 310 with Basic Stand



2. Insert the enclosure mounting tabs into the stand mounting slots.

Figure 3-15 Installing the Enclosure in the Basic Stand

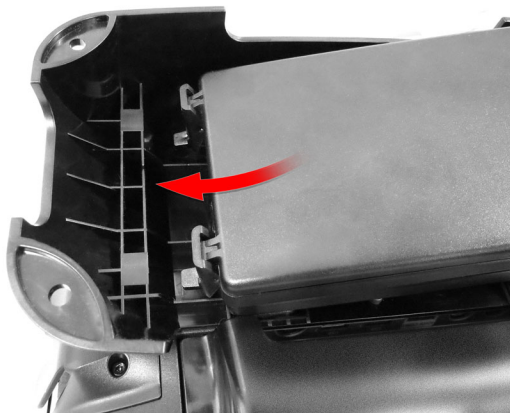

3. Tighten the stand thumbscrew (1) to secure the enclosure to the stand.

Figure 3-16 The Oracle MICROS Basic Stand with the Enclosure for Battery

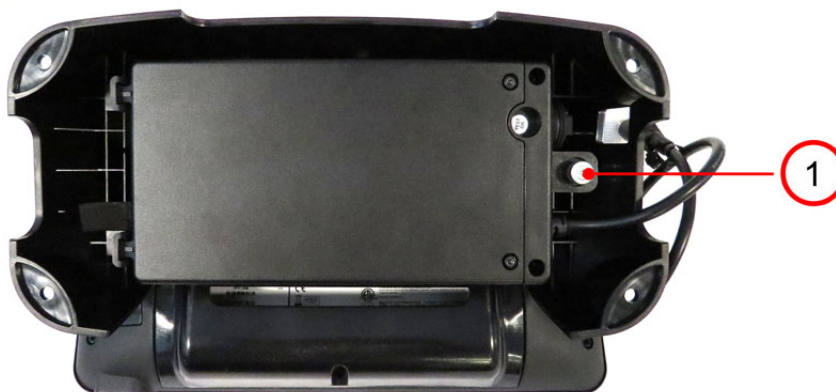

4. Connect the workstation Power Adapter (15V) to the DC power input, and then plug the Power Adapter into an outlet to charge the battery.

Installing the Oracle MICROS Powered Serial Port and Pole Display Expansion Module

Follow the steps below to install and configure the Oracle MICROS Powered Serial Port and Pole Display Expansion Module.

1. Download the Oracle MICROS Powered Serial Port and Pole Display Expansion Module installer from My Oracle Support at <https://support.oracle.com>, extract the files to your workstation, and then run **USBCSerialExpansionAPIsInstaller.exe** and follow the on-screen instructions. The workstation reboots twice during installation.
2. After completing the software install, power off the workstation, and then proceed with Step 3.
3. Place the Flexible Stand on its side or upside down on a flat surface.
4. Insert the Expansion Module into position **1** by placing the module mounting hole over the stand socket screw and pressing down.

Figure 3-17 Installing the Expansion Module on the Flexible Stand

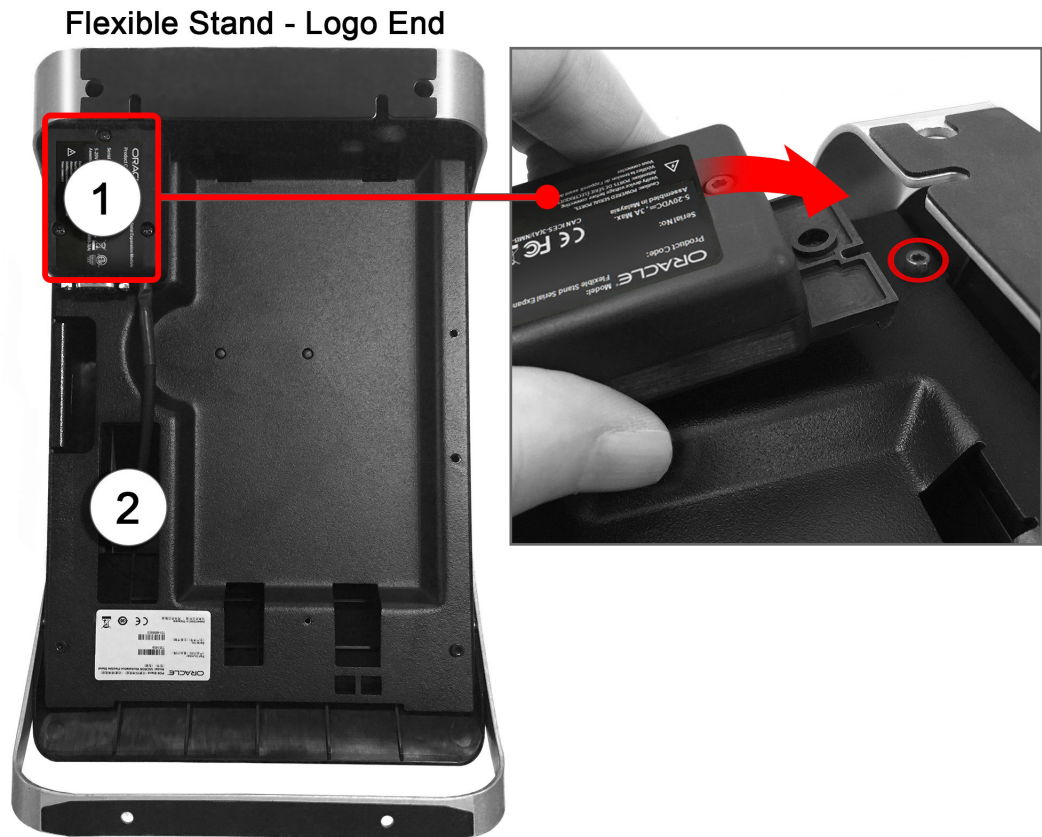

5. Feed the Expansion Module cable through the bottom of the stand at position **2**, and then connect it to the USB5 port on the Oracle MICROS Compact Workstation 310/310R.
6. Open the Yarrowsburg diagnostics utility from C:\Bin, scroll to the bottom, and then select **USB Dongle**.
7. For COM 7, select the correct voltage setting from the drop-down list, and then click **Set Voltage**.
8. For COM 8, select the correct voltage setting from the drop-down list, and then click **Set Voltage**.
 - a. For any devices using an external power supply (most use cases), select 0 volts.
 - b. The rear display port is already set to the correct voltage and cannot be changed.
9. Connect the correct hardware devices to COM 7 (DB9) and COM 8 (RJ45).

Note: The Oracle MICROS Powered Serial Port and Pole Display Expansion Module is not a hot-pluggable device.

- If you connect the Expansion Module to a powered-on workstation, you must restart the workstation to activate the module.
- If you disconnect the Expansion Module from a powered-on workstation, you must reconnect it and then restart the workstation to reactivate the module.

Installing the Biometric Fingerprint Module

The Compact Workstation 310 supports an optional biometric fingerprint module. The hex key is required for installation.

Note: Power off the workstation before installing the fingerprint module.

1. Place the workstation face down on flat surface, and then use the hex key to remove the screw from the dummy cover. Lift the cover out of the slot.

Figure 3-18 Removing the Dummy Cover



2. Drop the fingerprint module into the open slot.

Figure 3-19 Installing the Fingerprint Module



3. Use the hex key to secure the fingerprint module.

Securing the Workstation to a VESA Mount

The Compact Workstation 310 supports mounting the workstation display to a VESA mount. The workstation display is engineered in accordance with the Flat Display Mounting Interface (FDMI) Standard, otherwise known as the Mounting Interface Standard (MIS), defined by VESA. The VESA standard defines the dimensions of a display's four-hole attachment panel and dictates the placement of the hole pattern on the back of the workstation display.

When choosing a mounting bracket, look for VESA-compliant brackets.

4

Technical Specifications

The following table contains the technical specifications for the Compact Workstation 3 Series.

Table 4-1 Technical Specifications for the Oracle MICROS Compact Workstation 3 Series

Feature	310	310R/320R
Processor	Intel Atom x5-E3930 Processor @ 1.30GHz, 2C/2T, 2M Cache, (Apollo Lake) 320R: Intel Atom x7-E3950 Processor @ 1.60GHz, 4C/4T, 2M Cache, (Apollo Lake)	
Display	10.1", 16:10 WXGA, 1280(H) x800(V), 262k colors (RGB 6-bits), brightness= 300 Nits	10.1", 16:10 WXGA, 1280(H) x800(V), 262k colors (RGB 6-bits) brightness= 800 Nits
Customer Display	256 x 64 Graphical OLED Display	
Touchscreen	Projected capacitive touchscreen with 10-point simultaneous touch	
Memory	4GB DDR3L @ 1600 MHz standard (8GB MAX). 320R: 8GB standard	
Storage	First release of 310/310R: 64GB eMMC v5.0, 400MB/sec MAX. Non-removable. 310/310R/320R: Supports SATA storage (310R: 64GB / 320R: 128GB)	
Operating System	Microsoft Windows 10 IoT Enterprise (64-bit only)	
Magnetic Card Reader	3 track, encryption-capable with Merchantlink encryption key pre-injected	
Network	10/100/1G Ethernet, optional WiFi w/ Bluetooth	
USB	5 Total: <ul style="list-style-type: none"> • 2 USB 2.0 on I/O Panel (+5V @ 0.5A / 2.5W) • 2 USB on I/O Panel (+5V @ 0.9A / 4.5W) • 1 USB on I/O Panel (+5V/+15V @ 3.0A) 	
Serial Ports	2 Total: <ul style="list-style-type: none"> • 1 - RJ45 RS422/RS232 IDN • 1 - RJ45 RS232 	
Cash Drawer Ports	2 Total. For use with Series 2 Cash Drawers. Dongle available to convert Series 1 Cash Drawers to Series 2.	
Power Supply	External brick, 15V@5.33A (80W), 80~264VAC input. Optional battery power pack available.	
Weight	Workstation only: 3.64 lbs. Workstation with Flexible stand = 9.0 lbs.	
Dimensions	7.5 x 11.6 x 1.9 in / 191 x 294 x 47mm	
Operating Temperature	0-50C (32-122F)	-10-60C (14-140F)

Table 4-1 (Cont.) Technical Specifications for the Oracle MICROS Compact Workstation 3 Series

Feature	310	310R/320R
Resistance to Spills and Debris	IP43 for Compact Workstation 310, IEC/EN 60529-22	IP45 for Compact Workstation 310R, IEC/EN 60529-22 Compact Workstation 310R is IP45 rated when all unused ports are sealed using the included rubber port plugs.
Impact Resistance	EN62262–IK07: Impact energy= 2.0 joules	

Power Considerations for Peripheral Devices

The following table specifies the I/O port or connectors, their related power bus, and the power consumed by the port, depending on BIOS or Diagnostics Utility configurations. Use the table when considering peripherals.

Table 4-2 Port Power Specifications

Port or Connector	Available Power Capability
Series 2 Cash Drawer	Can be configured as +24V or +12V, with a shared 1A rating
USB 2.0	+5V @ 0.5A (2.5W)
Customer Display	+5V @ 1.5A (7.5W)
USB	+5V @ 09A (4.5W)
USB	+5V/+15V @ 3.0A

5

Software Components

This section describes the software components available for the Compact Workstation 3 Series.

The Compact Workstation 3 Series is available with Microsoft Windows 10 IoT Enterprise or the Oracle Linux for MICROS operating system.

Microsoft Windows 10 IoT Enterprise Operating System

The Compact Workstation 3 Series is available with the Microsoft Windows 10 IoT Enterprise operating system pre-installed. This operating system offers the latest Windows 10 Enterprise innovations to the POS industry as well as enterprise-grade security and reliability to ensure your devices and data are protected against modern security threats. Features include:

- Comprehensive infrastructure and management features provide flexibility, consistency, and advanced security.
- Built-in defenses, such as Secure Boot, BitLocker, Device Guard, and Credential Guard, protect your information from leaks or theft.
- Advanced lockdown capabilities, such as AppLocker, help create a dedicated device experience for business applications.
- Support for Universal Windows apps and Classic Windows applications create a flexible and all-inclusive workspace.
- Native-device interoperability provides manageability and a connected organization.

Oracle Linux for MICROS Operating System

The Compact Workstation 3 Series is available with the Oracle Linux for MICROS operating system pre-installed. Oracle Linux for MICROS provides reliability, scalability, security, and performance for demanding enterprise workloads. Features include:

- Free to use, free to distribute, free to update.
- Zero-downtime kernel and user space updates with Ksplice.
- Comprehensive kernel and application tracing with DTrace.
- Linux management and high availability included at no additional charge for Oracle Linux Support customers.
- Optimized for Oracle, including Oracle Database and Oracle Applications.
- Increase security by applying patches sooner and minimizing time spent troubleshooting and updating.
- Improve performance of Oracle software and hardware .
- Proven performance and reliability in Oracle Engineered Systems and Oracle Cloud.

Oracle Linux for MICROS Commands



Note:

Most deployments of Oracle Linux for MICROS do not require extensive Linux command line operations. Oracle Linux for MICROS commands are case sensitive.

Open another terminal

- Press **Ctrl+Alt+Fx** (where x = 4, 5, or 6) to open another terminal window.
- Press **Ctrl+Alt+F4**: Log in as **possupport**.

Find Linux image version information

- `cat /etc/micros-release`

Find network address of device

- `ifconfig`

Find network address of device

- `ip addr`

Check network status

- `nmcli device status`

Configure network

- `nmtui`

Verify contact to a remote host

- `ping 10.209.76.197`

Monitor the running processes, memory, and CPU usage

- `top`
- Press **q** to exit top command.

End a running process

- `kill 4465`

Edit a text file

- `nano webconfig.txt`

Restart the device

- `reboot`

Turn off the device

- `shutdown now`
- *Note for workstations with Oracle Linux for MICROS:* You can press and release the workstation power button to perform a graceful shutdown. Shutdown can take up to 10 seconds to complete.

Compact Workstation 3 Series Platform

The Compact Workstation 3 Series platform software includes the following components:

- **Hardware Device Drivers** specific to each configuration of the Compact Workstation 3 Series.
- The **Compact Workstation 310 API Driver** that allows applications to access the unique POS capabilities of the Compact Workstation 310.
- The **OPOS Driver** that allows third-party applications to use integrated peripherals and custom ports, such as the magnetic card reader, customer display, and cash drawer ports through industry-standard OPOS commands.
- A **Diagnostic Utility** that provides the resources for testing functionality and validating software versions. The utility allows users to test peripheral components.
- The **Oracle MICROS Client Application Loader** for remotely managing the software on each configuration of the Compact Workstation 310.

6

Workstation Accessibility Features

The following table contains the workstation accessibility features for the Compact Workstation 3 Series with the Microsoft Windows 10 IoT Enterprise operating system.

Table 6-1 Accessibility Features for the Compact Workstation 3 Series with the Microsoft Windows 10 IoT Enterprise Operating System

Feature	Behavior	Setup
Magnifier	In Full-Screen Mode , your entire screen is magnified. Depending on the size of your screen and the zoom level you choose, you might not be able to see all of the screen at the same time.	Select Control Panel > Ease of Access Center > Start Magnifier > Views > Full screen .
	In Lens Mode , the area around the mouse pointer is magnified. When you move the mouse pointer, the area of the screen that's magnified moves along with it.	Select Control Panel > Ease of Access Center > Start Magnifier > Views > Lens .
	In Docked Mode , only a portion of the screen is magnified, leaving the rest of your desktop unchanged. You can then control which area of the screen is magnified.	Select Control Panel > Ease of Access Center > Start Magnifier > Views > Dock .
Text or Visual Alternative to Sounds	The Turn on visual notifications for sounds option replaces system sounds with visual cues, such as a flash on the screen, so you can see notifications even when they're not heard. You can also choose how you want sound notifications to warn you.	Select Control Panel > Ease of Access Center > Use text or visual alternatives for sounds > Turn on visual notifications for sounds . Then, select a visual warning: <ul style="list-style-type: none"> • 1-None • 2-Flash active caption bar • 3-Flash active window • 4-Flash desktop
	The Turn on text captions for spoken dialog option displays text captions in place of sounds to indicate that activity is happening on your PC (for example, when a document starts or finishes printing).	Select Control Panel > Ease of Access Center > Use text or visual alternatives for sounds > Turn on text captions for spoken dialog .

Table 6-1 (Cont.) Accessibility Features for the Compact Workstation 3 Series with the Microsoft Windows 10 IoT Enterprise Operating System

Feature	Behavior	Setup
On-Screen Keyboard	The Use click sound option lets you hear a sound when you press a key.	Select Control Panel > Ease of Access Center > Start On-Screen Keyboard (OSK) > Options Key on keyboard > Use click sound.
	The Show keys to make it easier to move around the screen option allows the keys to light up as you type.	Select Control Panel > Ease of Access Center > Start On-Screen Keyboard (OSK) > Options Key on keyboard > Show keys to make it easier to move around the screen.
	The Turn on numeric keypad option expands the On-Screen Keyboard (OSK) to show a numeric keypad.	Select Control Panel > Ease of Access Center > Start On-Screen Keyboard (OSK) > Options Key on keyboard > Turn on numeric keypad.
	The Click on keys option lets you click or tap the on-screen keys to enter text.	Select Control Panel > Ease of Access Center > Start On-Screen Keyboard (OSK) > Options Key on keyboard > Click on Keys.
	The Hover over keys option lets you use a mouse or joystick to point to a key. The characters you point to are entered automatically when you point to them for a specified time.	Select Control Panel > Ease of Access Center > Start On-Screen Keyboard (OSK) > Options Key on keyboard > Hover over keys.
	The Scan through keys option allows the OSK to continually scan the keyboard. Scan mode highlights areas where you can type keyboard characters by pressing a keyboard shortcut, using a switch input device, or using a device that simulates a mouse click.	Select Control Panel > Ease of Access Center > Start On-Screen Keyboard (OSK) > Options Key on keyboard > Scan through keys.
	The Use Text Prediction option allows the OSK to suggest words as you type so you don't need to type each complete word.	Select Control Panel > Ease of Access Center > Start On-Screen Keyboard (OSK) > Options Key on keyboard > Use text prediction.
Narrator	Narrators read text on your PC screen aloud and describes events, such as notifications or calendar appointments, so you can use your PC without a display.	Select Control Panel > Ease of Access Center > Start Narrator.

Table 6-1 (Cont.) Accessibility Features for the Compact Workstation 3 Series with the Microsoft Windows 10 IoT Enterprise Operating System

Feature	Behavior	Setup
Speech Recognition	Windows Speech Recognition lets you control your PC with your voice alone, without needing a keyboard or mouse.	Select Control Panel > Speech Recognition .

7

Diagnostics Utility

This utility lets you view information about the workstation, test features to confirm their functional state, and configure peripheral and option devices.

If logged in as a non-Administrator account, the Administrator password is required to access the Diagnostics Utility.

Starting the Compact Workstation 3 Series Diagnostics Utility

1. Press **Start**.
2. Press **File Explorer**.
3. Navigate to the `C:\Bin\` folder.
4. Double-tap **Yarrowsburg_Diagnostic_UTILITY.exe**.

For ease of access, you can create a shortcut and place the shortcut on the Desktop.

Viewing System Information

On the System Information tab, you can view and confirm system diagnostic information as described in the following table:

Table 7-1 Diagnostics: System Information

Field	Description
Diagnostic Version	The Diagnostics Utility version.
RAM Size (bytes)	Shows the total RAM capacity.
Physical Address (ENET)	Shows the network MAC address assigned to the Ethernet port.
Physical Address (Wi-Fi)	Shows the network MAC address assigned to the wireless adapter.
IP Address	Shows the DHCP IP address assigned to the workstation.
C Total Size (bytes)	Shows the total capacity of the C drive.
C Free Size (bytes)	Shows the available capacity of the C drive.
D Total Size (bytes)	Shows the total capacity of the D drive.
D Free Size (bytes)	Shows the available capacity of the D drive.
Microsoft Window Ver	Shows the Microsoft Windows operating system version number.
Driver Version	Shows the PCWSAPI driver version number.
Workstation Model	Shows the workstation model.
BIOS Version	Shows the BIOS version number.
Hardware Revision	Shows the System Board revision letter.

Table 7-1 (Cont.) Diagnostics: System Information

Field	Description
UED CTRL Version	Shows the USB port driver version number. The Compact Workstation 310 uses this driver to enable or disable USB ports.
E2PROM Driver Version	Shows the E2PROM driver version number.
CAL Version	Shows the Client Application Loader version number.
EC Version	Shows the Embedded Controller firmware version number.
EC Bootloader Version	Shows the Embedded Controller Bootloader version number.
Motherboard SN	Shows the motherboard serial number.
UUID	Shows the Universally Unique Identifier, which enables distributed systems to uniquely identify information without significant central coordination.
Coin Battery Voltage	Shows Real-Time Clock battery voltage.

Testing the LCD Display

On the LCD Display tab, you can test the following LCD display features:

- Brightness
 - Backlight
 - Colors
 - Backlight Controls
1. To test brightness, press the **Dim**, **Normal**, and **Bright** buttons in the LCD Intensity Control group.
 2. To test the backlight, press **Backlight Off** to ensure the backlight turns on and off.
 3. To test the colors, press the **Red**, **Green**, **Blue**, **Black**, and **White** buttons in the Display Color group.
 4. To manage the backlight controls and set a timer to switch off the backlight after a period of inactivity:
 - a. Enter a time in seconds in the **Backlight Reprime** field. Set the value to 0 to disable the timer and allow the backlight to stay on indefinitely.
 - b. Press **Reprime Backlight** to set the timer.
 - c. Press **Backlight On** to enable the timer.
 - d. To disable the timer after testing, press **Backlight Off**.

Testing the Integrated Magnetic Stripe Reader

On the MSR tab, you can test that the integrated magnetic stripe reader functions correctly and retrieves the expected results.

You can test the card reader in:

- **Special Mode:** This mode converts scanned data into a buffer and sends the information to an application for processing. Special Mode accepts inputs in 2 or 3 tracks.
- To reset the mag reader settings, press **Set to Special Mode**.

Testing the Encrypted Magnetic Stripe Reader

On the Encrypted MSR tab, you can test the magnetic card reader with encryption enabled. By default, this is disabled.

Testing the Customer Display

On the Customer Display tab, you can test the connectivity and functionality of an integrated 240 x 64 Customer Display.

On the Customer Display Ex tab, you can test the graphics capabilities of an integrated 240 x 64 Customer Display and retrieve the integrated firmware version.

On the Customer Display 2x20 tab, you can test the connectivity and functionality of an integrated 2 x 20 text-based Customer Display.

Testing the Cash Drawers

On the Cash Drawer tab, you can make sure the connected cash drawers correctly open and that the system recognizes the open and close state of the cash drawers.

By default, you can determine the password by applying the following formula to the key:

Digit 1 * Digit 2 + Digit 4 + Digit 6 = Password

For example, if the utility shows the key 532586, the password is 26 (5*3+5+6).

1. Click **Open Cash Drawer [Number]** to open the connected cash drawer.
2. Click **Read Cash Drawer [Number] Status** to check the open and close status of the connected cash drawer.

Performing an RS232 Loopback Test

On the RS232 LoopBack tab, you can perform a loopback test on a single port using an RS232 Self LoopBack Unit.

1. Connect a serial loopback connector to the workstation COM port 1 and 4. You can also connect a serial cable between two COM ports.
2. Select the output and input ports.
3. Press **Test Ports**.
4. Verify that the **Tx Bytes** field and the **Rx Bytes** field increments.
5. Press **Quit Test**.

Testing an RS232 Printer

On the RS232 Print tab, you can test connectivity and print line-by-line at a serial printer.

1. Connect the RS232 cable from the printer to the workstation COM port 1 and 4.
2. Select the COM port from the **Output Port** drop-down list.
3. Press **Test Ports**.
4. Verify that the **Tx Bytes** field and the **Rx Bytes** field increments and that the printer continues printing.
5. Press **Quit Test**.

Performing an IDN Loopback Test

On the IDN LoopBack tab, you can perform a loopback test using an IDN loopback device.

1. Connect the loopback device to the workstation COM port 4.
2. Select COM4 from the **Output Port** and the **Input Port** drop-down lists.
3. Press **Test Ports**.
4. Verify that the **Tx Bytes** field and the **Rx Bytes** field increments.
5. Press **Quit Test**.

Testing an IDN Printer

On the IDN Print tab, you can test connectivity and print line-by-line at an IDN Roll Printer with an ID of 1. You must have an RS422 (6 pin to 8 pin) cable.

1. Connect the 8-pin end to the workstation COM port 4.
2. Connect the 6-pin end to the printer IDN port 1.
3. Select **COM4** from the **Output Port** drop-down list.
4. Press **Test Ports**.
5. Verify that the **Tx Bytes** field and the **Rx Bytes** field increments and that the printer continues printing line-by-line.
6. Press **Quit Test**.

Viewing Diagnostics Reports for Devices on COM Ports

On the Devices tab, you can monitor and retrieve diagnostics reports or data from selected peripheral devices.

Viewing Hardware Controls

On the Hardware Control tab, you can:

- Enable and disable USB ports. This is used for testing and enabling/disabling the USB ports.
- Set the voltage level for USB port 5.

By default, you can determine the password by applying the following formula to the key:

Digit 1 * Digit 2 + Digit 4 + Digit 6 = Password

For example, if the utility shows the key 532586, the password is 26 (5*3+5+6).

Viewing Diagnostics Reports for I2C Devices

On the I2C Devices tab, you can:

- Retrieve information from an RFID tag.
- Retrieve data from EEPROM memory.

Testing the Fingerprint Reader

This utility tests the fingerprint reader's ability to scan a fingerprint and validate the fingerprint read accuracy.

1. On the diagnostic main screen, scroll down in the list of devices, and then tap **Fingerprint Reader**.
2. On the *Fingerprint Reader* screen, tap **Device Selection**.
3. Tap **Select** to select the fingerprint reader device, or tap the **Devices List** drop-down and select your device.
4. Tap **Acquire Fingerprint**. The *Enroll a Fingerprint* screen appears.
5. To enroll a fingerprint, tap a finger on one of the hand icons. The *Enroll a Fingerprint — Scan your finger* screen appears.
6. Place your finger on the fingerprint reader and wait until success is confirmed. Ensure the finger you place on the reader matches the finger you chose in the previous step. For each successful enrollment, a number will turn blue starting with 1. A total of 4 enrollments per finger are allowed. After successfully enrolling a fingerprint, the screen disappears.
7. Tap **Close** on the *Enroll a Fingerprint* screen.
8. Tap **Validate Fingerprint**.
9. To validate enrollment, touch the fingerprint reader with the enrolled finger.
 - Valid fingerprint: OnIdentify: One or more matches. Try another finger.
 - Invalid fingerprint: OnIdentify: No matches. Try another finger.

Battery Monitor

The Battery Monitor displays detailed real-time battery information for up to four BPPs (Battery Power Packs).

The information for each BPP is organized into three sections:

- BPP (Battery Power Pack) Details: Includes BPP Serial Number, EC Firmware, Bootloader Version, Index
- Battery Details: Includes Manufacturer, Battery Internal ID#, Battery Type, Capacity, Cycle Count, Voltage, Current, Internal Battery Temp, State of Charge, Battery Status, Battery Condition, and Battery Alarm.

- Battery Operation Mode: 1. Normal – Sets Start/Stop Charging Threshold 90%/100% 2. Backup – Sets Start/Stop Charging Threshold 70%/80%.

8

BIOS Configuration

This section describes how to enter the BIOS System Configuration Utility and how to configure the system BIOS.

Starting the BIOS Configuration Utility

To configure the BIOS, start the BIOS configuration utility using the following steps:

- Power on the workstation, and then tap the left or right lower third of the BIOS splash screen until the system beeps and the BIOS Home screen appears.
- 1. Connect a USB keyboard to the Compact Workstation 310.
- 2. Power on or restart the workstation.
- 3. Press **F2** at the BIOS splash screen. The system beeps and the BIOS Home Screen appears.

If the workstation boots into the operating system without starting the BIOS configuration utility, restart the workstation and try again.

Viewing System Information

On the BIOS Home screen, tap **Main**, and then tap **System Information**.

The following is an example set of information presented by the BIOS System Information screen. The actual data shown by your system may vary.

- BIOS Version: 0.3.0.0 X64
- Build Time: 11/07/2017
- Processor Type: Intel(R) Atom(TM) Processor E3950 @ 1.60GHz
- Processor Speed: 1.600 GHz
- System Memory Speed: 1600 MHz
- L2 Cache RAM: 1024 KB
- Total Memory: 4096 MB
- Memory Device: 4096 MB (DDR3-1600) @ ChannelA-DIMM0

Configuring System Security Settings

On the Security screen, configure the settings as described in the following table:

Table 8-1 BIOS Security Settings

Setting	Description of Option
Secure Boot Configuration	Disabled by default. To enable, set the Supervisor Password .
Secure Boot Option	Turn the UEFI secure boot firmware validation process Off or On .
Reset to Default	Reset secure boot variables to the factory default.
Change to Customization	Delete the protection key, change the platform to setup mode, and disable secure boot.
Set Supervisor Password	Set or clear the supervisor password.
Supervisor Hint String	Enter a hint for the password.
Min. Password Length	Set a minimum length to enforce for user passwords.
HDD Password Select	Select the password structure to apply to hard disk drives: <ul style="list-style-type: none"> • User Only: Supports user account passwords. • User + Master: Supports user account passwords and a master password.
Set HDDNumber User Password	Set a password for the user account for this HDD.
Set HDDNumber Master Password	Set a master password for this HDD.
TPM Device	To access this option, tap Advanced , tap System Setup , and then tap Enter on the Security Configuration option. Select PTT (Intel Platform Trust Technology) to Enable or Disable Trusted Platform Module support. The TPM Device is disabled by default.
PTT Enabled PCR Banks	This option is available when the TPM Device option is set to PTT. Select the Secure Hashing Algorithm to use with PTT/TPM. SHA1 is a 160-bit hash algorithm. SHA256 is a 256-bit hash algorithm. Both enables concurrent use of SHA1 and SHA256 algorithms.

Configuring the Boot Priority for Devices

To edit the device boot priority:

1. From the BIOS Home screen, tap **Boot**. The Edit Boot Order screen appears.
2. In the list of devices, tap and hold a device you want to reorder, and then drag and drop it above or below other items in the list.

The BIOS reads the devices from top to bottom in determining the method for booting into the operating system.

For example, if you want the workstation to boot from a USB drive, make sure to place the USB drive device higher on the list than the eMMC Card device.

Exiting the BIOS Configuration Utility

To exit the BIOS from the Home screen, tap **Save & Exit**.

- **Exit Saving Changes:** Save the current configuration settings, exit the configuration utility, and boot into the operating system.
- **Exit Discarding Changes:** Discard the current configuration settings, exit the configuration utility, and boot into the operating system.
- **Load Setup Defaults:** Load the default UEFI settings.
- **Discard Changes:** Discard the current configuration settings without exiting the configuration utility. This resets the configurations to the last saved state.
- **Save Changes:** Save the current configuration settings without exiting the configuration utility.

Special Configuration Settings

Caution: Do not change Special Configuration settings without guidance because incorrect or incompatible settings may cause the system to fail.



The Compact Workstation 310 ships with the BIOS pre-configured for optimal performance. In most cases you will not need to change settings.

To access the Special Configuration settings:

1. From the BIOS Home screen, tap **Advanced**, and then tap **Special Configuration**.

Table 8-2 Special Configuration Settings

Setting	Description of Option
USB Port 1	Enable or Disable USB port 1.
USB Port 2	Enable or Disable USB port 2.
USB Port 3	Enable or Disable USB port 3.
USB Port 4	Enable or Disable USB port 4.
USB Port 5 (High Power)	Select USB - 15V or USB - 5V for USB port 5.
422 Mode Selection	Enable or Disable RS-422 mode for the IDN port.
422/232 Mode Selection	Select 422 Mode or 232 Mode to enable RS-422 mode or RS-232 mode for the IDN port.

Table 8-2 (Cont.) Special Configuration Settings

Setting	Description of Option
Power Failure Restoration	Select the action taken by the system in the event of a power failure: <ul style="list-style-type: none">• Remain Off: The system remains powered off even if it was originally powered on.• Last State: If the system was on when power failed, the system powers on. If the system was off, the system remains off.• Power On: The system powers on even if it was originally powered off.
Factory Recovery	Select factory recovery settings: <ul style="list-style-type: none">• Disable: You cannot perform factory recovery.• Enable: You can perform factory recovery.
Casework Open Action	Select the action taken by the system if the workstation casework is compromised: <ul style="list-style-type: none">• Startup Warning: Presents a warning during startup if the system detects the workstation casework was compromised.• Forced Off: Turns off the workstation if the system detects the casework was compromised.

9

Equipment Dimensions

This section contains the equipment dimensions for the Compact Workstation 310.

Dimensions – Compact Workstation 310 with Flexible Stand

Figure 9-1 Dimensions with Flexible Stand



Dimensions – Compact Workstation 310 with Basic Stand

Figure 9-2 Dimensions with Basic Stand

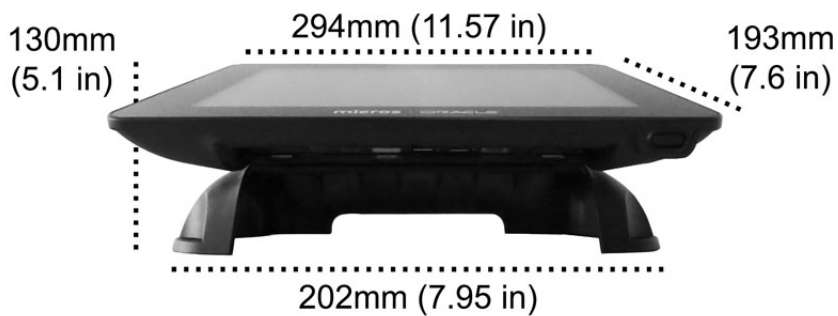

10

I/O Panel Connectors and System Diagrams

This section describes the input/output panel connectors and the system block diagrams for the Compact Workstation 3 Series.

I/O Panel Connectors

This section depicts the input/output panel connectors.

IDN RS422/232

You can configure the IDN connector to run in RS422 mode or RS232 mode as shown in the following table.

Table 10-1 IDN Pin Reference

RS422	RS232
-------	-------

Figure 10-1 RS422 Mode

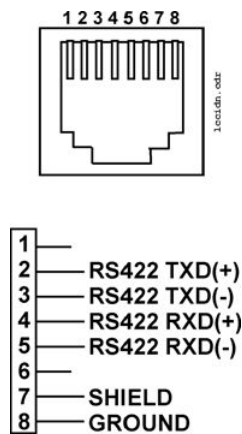
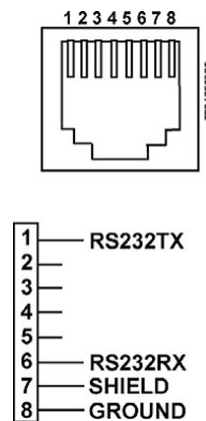

Figure 10-2 RS232 Mode



RJ45

The RJ45 connector contains the following pins.

Figure 10-3 RJ45 Pin Reference

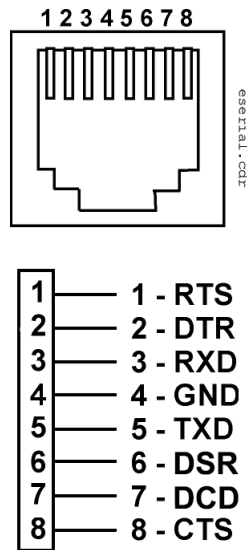

Series 2 Cash Drawer

The Series 2 Cash Drawer connector is an 8-pin Mini-DIN. You can convert this connector into a traditional 4-pin DIN connector by using a P/N 300290-020-PT cable.

Figure 10-4 Series 2 Cash Drawer Pin Reference

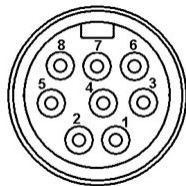

The following table describes the signal name and function of each pin.

Table 10-2 Series 2 Cash Drawer Pin and Signal Reference

Pin #	Signal Name	Description
1	VCC12 or VCC24	Cash drawer power
2	CD_OPEN	Open drawer
3, 7, 8	Ground	Signal grounds
4	CD_ST	Input status from cash drawer
5	MCU_TX_5V	Tx data to cash drawer
6	MCURX	Rx data from cash drawer

USB Ports

The Compact Workstation 3 Series includes five USB ports.

- 2x USB 2.0: +5V @ 0.5A (2.5W)
- 2x USB: +5V @ 09A (4.5W)
- 1x USB: +5V/+15V @ 3.0A

System Block Diagrams

The image in this section depicts the system block diagram for the Compact Workstation 310.

Compact Workstation 310 System Block Diagram

The following diagram depicts the main board for the Compact Workstation 310.

Figure 10-5 System Block Diagram of the Compact Workstation 310

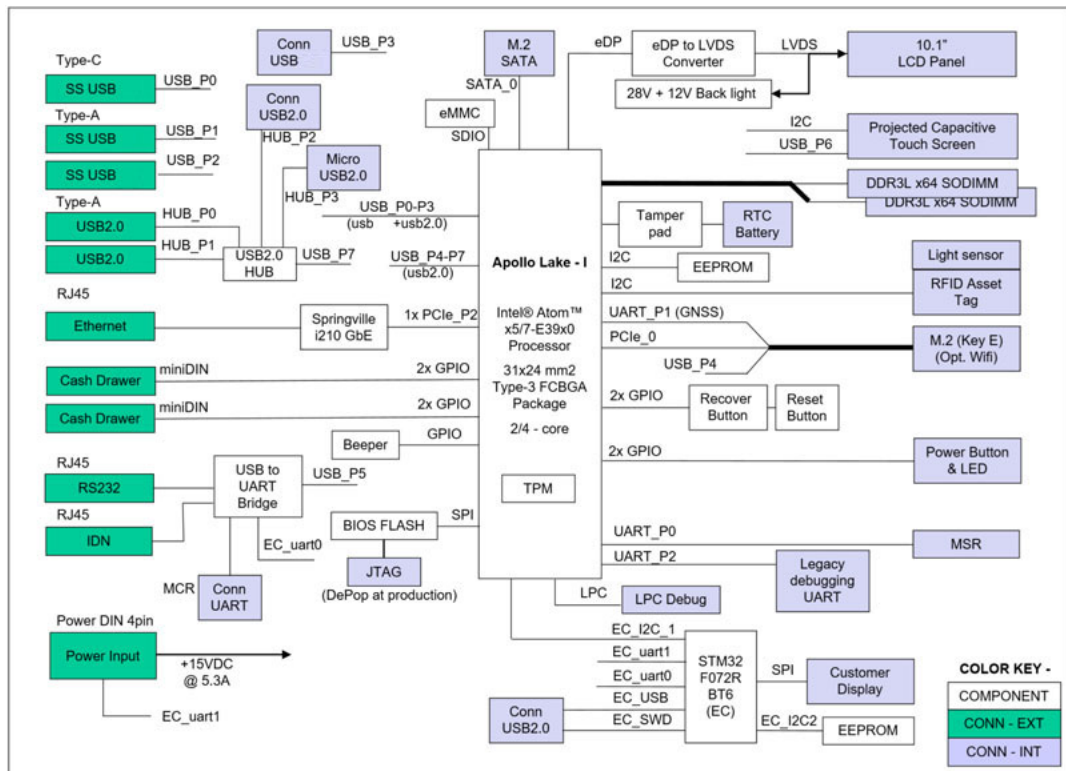

11

Troubleshooting

This section provides instructions for general troubleshooting tasks.

Basic Troubleshooting

The following table contains descriptions and solutions for common problems encountered when installing or operating the Compact Workstation 3 Series.

Table 11-1 Basic Troubleshooting

Problem	Possible Causes	Solution
The workstation does not start and does not show the splash screen.	No power to the workstation.	Make sure you connected the AC power cable to the workstation and to a surge-protected outlet, UPS, power conditioner, wall outlet, or a charged battery power pack.
The workstation does not start and the screen remains blank after 30 seconds.	Missing or defective SO-DIMM.	Re-seat SO-DIMM 0.
The workstation does not start. The operator LED stays off or stays on. The operator LCD remains blank after 30 seconds.	The system board may be defective.	Contact your Oracle MICROS representative.
The workstation does not connect to the Local Area Network.	The Network Patch cable is not connected.	Install the appropriate patch cable between the workstation and the wall jack.
The workstation does not read mag cards.	The mag card reader head is dirty or contaminated. The mag card reader is defective.	Use the mag card cleaning kit on the reader. Replace the magnetic stripe reader.

System Recovery

A system recovery is used to:

- Wipe the hard drive.
- Restore all PC settings to factory settings.
- Remove all user accounts and settings.
- Remove all after factory installed applications.

To perform a system recovery, you can use the BIOS, the workstation's recovery button, or the Microsoft Windows operating system recovery function.

Check My Oracle Support (<https://support.oracle.com>) for updated OS image before performing factory recovery. An updated image contains new Windows Security updates and any new operating system configuration settings made since last released image.

Performing a System Recovery for Microsoft Windows 10

You can use the Microsoft Windows 10 operating system recovery function to restore system settings. The system recovery for Microsoft Windows 10 has three recovery options. Each option is outlined below:

Reset this PC – Keep My Files Option

This recovery option takes about 1.5 hours and performs the following actions:

- Keeps personal files
 - Removes applications and drivers installed after default OS installation
 - Removes changes made to settings after default OS installation
 - Results in no OS configuration at startup
 - Reinstalls Microsoft Windows 10 and keeps your personal files
1. Swipe left on the touchscreen or move your mouse to the top-right corner of the start screen.
 2. Select **All Settings**.
 3. On the Update and Recovery screen, click the **Get started** button under **Reset this PC**.
 4. On the Reset this PC screen, select **Keep My Files**, and then select **Next** on the **Your Apps Will Be Removed** screen.
 5. Select **Reset** to finish restoring factory settings.
 6. When the restoration is complete, the workstation reboots into Microsoft Windows 10.

Reset this PC – Remove Everything – Just Remove My Files Option

This recovery option takes about 1.5 hours and performs the following actions:

- Performs a quick format on the drive
 - Deletes personal files and User accounts
 - Removes applications and drivers installed after default OS installation
 - Removes changes made to settings after default OS installation
 - Removes Windows Updates installed since last Windows installation
 - Performs Out-of-Box configuration at startup
1. Swipe left on the touchscreen or move your mouse to the top-right corner of the start screen.
 2. Select **All Settings**.
 3. On the PC Settings screen, select **Update and Recovery**.

4. On the Update and Recovery screen, select the **Get Started** button under Reset this PC.
5. Select **Remove Everything**.
6. Select **Just Remove My Files**.
7. Select **Resetto** finish restoring factory settings.
8. When the restoration is complete, the workstation reboots and begins the Microsoft Windows 10 configuration process.

Reset this PC – Remove Everything – Remove the Files and Clean the Drive Option

This recovery option takes 1.5 hours or more and includes the following actions:

- This procedure performs full format of the hard disk that involves a more secure erasure of your data
 - Deletes personal files and User accounts
 - Removes applications and drivers installed after default OS installation
 - Removes changes made to settings after default OS installation
 - Removes Windows Updates installed since last Windows installation
 - Performs Out-of-Box configuration at startup
1. Swipe left on the touchscreen or move your mouse to the top-right corner of the start screen.
 2. Select **All Settings**.
 3. On the PC Settings screen, select **Update and Recovery**.
 4. On the Update and Recovery screen, click the **Get Started** button under Reset this PC.
 5. Select **Remove Everything**.
 6. Select **Remove Files and Everything**.
 7. Select **Resetto** finish restoring factory settings.
 8. When the restoration is complete, the workstation reboots and begins the Microsoft Windows 10 configuration process.

Performing a Factory Reset from BIOS (Microsoft Windows)

This recovery process resets the workstation OS to the factory default and performs Out-of-Box configuration. This process takes about 15 minutes. If a Supervisor Password is set, it will be used to enter the BIOS to Enable Recovery.

To perform system recovery from the BIOS:

1. Power on or restart the workstation.
2. Enter the BIOS by tapping either the right or left bottom of the screen.
3. Tap **Advanced**, and then tap **Special Configuration**.
4. Tap **Factory Recovery**.
5. Select **Enabled** from drop-down menu.
6. Tap **Home**.
7. Tap **Save and Exit**.

8. Tap **Exit Saving Changes**, and then tap **Yes** to confirm. The Compact Workstation 310 automatically restarts.
9. On the Choose an Option screen, tap **Troubleshoot**.
10. On the Troubleshoot screen, tap **Factory Reset**.
11. Type **Y** to reset the Windows partition to the factory default.

Performing a Factory Reset from BIOS (Oracle Linux for MICROS)

This recovery process resets the workstation OS to the factory default.

To perform system recovery from the BIOS:

1. Power on or restart the workstation.
2. Enter the BIOS by tapping either the lower right or lower left bottom of the screen.
3. Tap **Advanced**, and then tap **Special Configuration**.
4. Tap **Factory Recovery**.
5. Select **Enabled** from drop-down menu.
6. Tap **Home**.
7. Tap **Save and Exit**.
8. Tap **Exit Saving Changes**, and then tap **Yes** to confirm. The Compact Workstation 310 automatically restarts.
9. The workstation reboots and the “*Entering Recovery Mode*” message appears.
10. When the “*The system will reset Oracle Linux to Factory Default.....Are you sure to continue? (Y/N)*” message appears, type **y**, and then press **Enter**.
11. The recovery process begins.

Performing a Factory Reset using the Recovery Button

Use this recovery process if you want to reset the workstation OS to factory default and perform Out-of-Box configuration. This process takes about 15 minutes. You can use the system recovery button to restore system settings without using a keyboard. If a Supervisor Password is set, it will be used to start the Recovery process.

1. Power off the workstation. Do not disconnect the power cable.
2. Press the recovery button using any object less than 2mm in diameter. The hole to access the button is located top left on the back of the unit near the dummy cover or fingerprint reader (if installed).
3. Power on the workstation. It briefly powers on, restarts, and then shows the Please Wait message below the splash screen.
4. On the Choose an Option screen, click **Troubleshoot**.
5. On the Troubleshoot screen, click **Factory Reset**.
6. Select **Y** to reset the Windows partition to factory default.
7. When the restoration is complete and the workstation restarts, you can begin the operating system setup.

12

Safety and Handling

This section contains important information regarding the safety, care, and handling of the Compact Workstation 310.

Safety Agency Compliance Statements

Safety Precautions

For your protection, observe the following safety precautions when setting up your equipment:

- Follow all cautions and instructions marked on the equipment.
- Ensure that the voltage and frequency of your power source match the voltage and frequency inscribed on the equipment's electrical rating label.
- Never push objects of any kind through openings in the equipment. Dangerous voltages may be present. Conductive foreign objects could produce a short circuit that could cause fire, electric shock, or damage to your equipment.
- This product is intended for restricted access whereby access is controlled through the use of a means of security (for example, key, lock, tool, badge access) and personnel authorized for access have been instructed on the reasons for the restrictions and any precautions that need to be taken.
- Do not directly connect this product to outdoor metallic communications cables. Always connect the product to outdoor metallic communications cables using a protection device that is designed for direct connection to outdoor metallic communications cables (such as a switch or router), or use optical non-metallic communications cables upon leaving the building.
- Do not directly connect this product to outdoor power cables.
 - For AC Power, connect the product only to an indoor power distribution system that uses current-limiting circuit breakers for AC power.
 - For DC Power, connect the product only to earthed power systems that are completely contained within one building.

Modifications to Equipment

Do not make mechanical or electrical modifications to the equipment. Oracle is not responsible for regulatory compliance of a modified Oracle product.

Placement of an Oracle Product



Caution: Do not block or cover the openings of your Oracle product. Never place an Oracle product near a radiator or heat register. Failure to follow these guidelines can cause overheating and affect the reliability of your Oracle product.

SELV Compliance

Safety status of I/O connections comply with SELV requirements.

Power Cord Connection



Caution: Oracle products are designed to work with power systems having a grounded neutral (grounded return for DC-powered products). To reduce the risk of electric shock, do not plug Oracle products into any other type of power system. Contact your facilities manager or a qualified electrician if you are not sure what type of power is supplied to your building.



Caution: Not all power cords have the same current ratings. Do not use the power cord provided with your equipment for any other products or use. Household extension cords do not have overload protection and are not meant for use with computer systems. Do not use household extension cords with your Oracle product.

The following caution applies only to devices with a Standby power switch:



Caution: The power switch of this product functions as a standby type device only. The power cord serves as the primary disconnect device for the system. Be sure to plug the power cord into a grounded power outlet that is nearby the system and is readily accessible. Do not connect the power cord when the power supply has been removed from the system chassis.

The following caution applies only to devices with multiple power cords:



Caution: For products with multiple power cords, all power cords must be disconnected to completely remove power from the system.

Figure 12-1 Disconnect Multiple Power Cords



Battery Warning



Caution: There is danger of explosion if batteries are mishandled or incorrectly replaced. On systems with replaceable batteries, replace only with the same manufacturer and type or equivalent type recommended by the manufacturer per the instructions provided in the product service manual. Do not disassemble batteries or attempt to recharge them outside the system. Do not dispose of batteries in fire. Dispose of batteries properly in accordance with the manufacturer's instructions and local regulations. Note that on the main board, there is a lithium coin cell battery installed in a battery holder. If you need to replace the lithium coin cell battery, use a Maxell CR2032 or equivalent battery type.

System Unit Cover

You must remove the cover of your Oracle computer system unit to add cards, memory, or internal storage devices. Be sure to replace the cover before powering on your computer system.



Caution: Do not operate Oracle products without the cover in place. Failure to take this precaution may result in personal injury and system damage.

International Compliance Information

OMAN - TRA
R/8049/19
D141225

Care and Handling

Equipment Placement

- Keep the Compact Workstation 310 within an operating temperature between 0C (32F) and 50C (122F).
- Keep the Compact Workstation 310R within an operating temperature between -10C (14F) and 60C (140F).
- If you are placing your equipment in an area adjacent to carpeting, use an anti-static grade of carpeting. If you do not have anti-static carpeting, use static discharge mats.
- Do not place equipment near food preparation areas, glass racks, or water stations. Although the Compact Workstation 310 is highly spill resistant, take care to avoid using electrical equipment near water.
- Take precautions to prevent the accidental dropping of metallic objects such as paper clips and staples into the equipment.

Electromagnetic Interference

- Do not run exposed cables in the vicinity of AC power lines because the noise radiating from the AC power lines can be absorbed by Compact Workstation 310 AC power and communication lines.
- Keep devices that emit RF energy, such as cordless phones, at least eight inches from the equipment or cable during operation.

Cleaning

LCD/Touchscreen

You can use any ammonia-free household cleaner or a 50/50 mix of isopropyl alcohol and distilled water applied with a clean, cotton cloth. Spray the cloth with the cleaner and then use the cloth to wipe the screen.

Cabinet

Use a chamois or a clean, lint-free cloth to clean the cabinet and screen surface. Do not use chemical, alcohol, or petroleum-based cleaners that are not recommended for plastics.

Magnetic Stripe Reader

Contact your Oracle representative for information and recommendations on magnetic stripe reader cleaning kits.