

**Oracle Symphony**  
System Interface Module (SIM) Manual  
**G49773-01**

June 2026

---

Oracle Symphony System Interface Module (SIM) Manual Release 19.10

G49773-01

Copyright © 2010, 2026, Oracle and/or its affiliates. All rights reserved.

This software and related documentation are provided under a license agreement containing restrictions on use and disclosure and are protected by intellectual property laws. Except as expressly permitted in your license agreement or allowed by law, you may not use, copy, reproduce, translate, broadcast, modify, license, transmit, distribute, exhibit, perform, publish, or display any part, in any form, or by any means. Reverse engineering, disassembly, or decompilation of this software, unless required by law for interoperability, is prohibited.

The information contained herein is subject to change without notice and is not warranted to be error-free. If you find any errors, please report them to us in writing.

If this software or related documentation is delivered to the U.S. Government or anyone licensing it on behalf of the U.S. Government, then the following notice is applicable:

U.S. GOVERNMENT END USERS: Oracle programs, including any operating system, integrated software, any programs installed on the hardware, and/or documentation, delivered to U.S. Government end users are "commercial computer software" pursuant to the applicable Federal Acquisition Regulation and agency-specific supplemental regulations. As such, use, duplication, disclosure, modification, and adaptation of the programs, including any operating system, integrated software, any programs installed on the hardware, and/or documentation, shall be subject to license terms and license restrictions applicable to the programs. No other rights are granted to the U.S. Government.

This software or hardware is developed for general use in a variety of information management applications. It is not developed or intended for use in any inherently dangerous applications, including applications that may create a risk of personal injury. If you use this software or hardware in dangerous applications, then you shall be responsible to take all appropriate fail-safe, backup, redundancy, and other measures to ensure its safe use. Oracle Corporation and its affiliates disclaim any liability for any damages caused by use of this software or hardware in dangerous applications.

Oracle and Java are registered trademarks of Oracle and/or its affiliates. Other names may be trademarks of their respective owners.

Intel and Intel Xeon are trademarks or registered trademarks of Intel Corporation. All SPARC trademarks are used under license and are trademarks or registered trademarks of SPARC International, Inc. AMD, Opteron, the AMD logo, and the AMD Opteron logo are trademarks or registered trademarks of Advanced Micro Devices. UNIX is a registered trademark of The Open Group.

This software or hardware and documentation may provide access to or information about content, products, and services from third parties. Oracle Corporation and its affiliates are not responsible for and expressly disclaim all warranties of any kind with respect to third-party content, products, and services unless otherwise set forth in an applicable agreement between you and Oracle. Oracle Corporation and its affiliates will not be responsible for any loss, costs, or damages incurred due to your access to or use of third-party content, products, or services, except as set forth in an applicable agreement between you and Oracle.

---

---

# Contents

<b>Tables</b> .....	<b>22</b>
<b>Figures</b> .....	<b>26</b>
<b>Preface</b> .....	<b>27</b>
Audience .....	27
Customer Support.....	27
Documentation.....	27
Revision History.....	27
<b>1 Before You Start</b> .....	<b>1-1</b>
Abbreviations, Conventions, and Symbols .....	1-1
Abbreviations .....	1-1
Conventions.....	1-1
<b>2 Understanding the SIM and ISL</b> .....	<b>2-1</b>
Getting to Know the SIM and ISL.....	2-1
What is the System Interface Module?.....	2-1
What is the Interface Script Language? .....	2-1
Script Writing .....	2-3
How the ISL Accesses the SIM.....	2-4
Features of the SIM .....	2-5
Message Formats and Interface Methods.....	2-5
Methods of Displaying, Capturing, and Printing Data .....	2-5
Interfacing with Third-party Systems.....	2-6
ISL File Handling .....	2-6
Creating SIM Applications with the ISL.....	2-7
Benefits of SIM Applications.....	2-7
Types of SIM Applications .....	2-7
Generating Coupons for Customers .....	2-7
Interfacing with a Pizza Delivery System.....	2-9
Collecting Customer Information for a Membership List.....	2-9
Customizing Output.....	2-10
<b>3 Getting Started</b> .....	<b>3-1</b>
Getting Started with the ISL and SIM .....	3-1
Developing the SIM Interface.....	3-1
Enabling SIM and a SIM Interface .....	3-1
Message Formats and Interface Methods .....	3-1

---

Message Formats.....	3-1
Interface Methods .....	3-4
<b>4 Script Writing Basics .....</b>	<b>4-1</b>
Getting Started with Script Writing .....	4-1
What is a Script?.....	4-1
Structure of a Script .....	4-1
Creating Scripts .....	4-2
Guidelines for Creating Scripts .....	4-3
Examples of Scripts.....	4-3
Script Writing Style.....	4-5
Case.....	4-5
Length of Variables.....	4-5
Comments (//).....	4-5
Continuation Lines (\) .....	4-5
Whitespace.....	4-6
Writing and Editing Scripts .....	4-7
Avoiding Errors .....	4-7
Testing Scripts .....	4-8
Detecting Errors in Logic .....	4-8
Stepping Through the Script .....	4-8
<b>5 Using Variables .....</b>	<b>5-1</b>
Variables and ISL .....	5-1
Data Types .....	5-1
Example.....	5-3
Relational and Logical Operators .....	5-3
Unary Operators .....	5-3
Binary Operators.....	5-4
Operator Rules .....	5-5
User Variables .....	5-6
Declaring User Variables .....	5-6
Local and Global Variables.....	5-7
Array Variables .....	5-10
Variable Size Variables.....	5-10
Using List Arrays and Records .....	5-11
Promotion .....	5-14
DefKey.....	5-15
<b>6 ISL Printing .....</b>	<b>6-1</b>
Getting Started with ISL Printing .....	6-1

---

ISL Print Commands and System Variables .....	6-1
Starting an ISL Print Job .....	6-1
ISL StartPrint Commands .....	6-1
Specifying an ISL Printer .....	6-2
Using Print Directives .....	6-4
The Printline Command.....	6-4
Print Type System Variables .....	6-4
Print Directives and Subroutines.....	6-5
Backup Printing.....	6-5
Considerations .....	6-6
Reference Strings.....	6-6
<b>7 ISL System Variables .....</b>	<b>7-1</b>
System Variables .....	7-1
System Variable Summary .....	7-1
Specifying System Variables .....	7-1
Specifying System Variables.....	7-1
Guidelines for Specifying System Variables .....	7-1
Using an Index to Specify System Variables.....	7-2
System Variable Summary.....	7-4
ISL System Variable Reference.....	7-12
ACTIVE_LANGID.....	7-13
ADDXFER_CHK_FROM .....	7-13
ADDXFER_CHK_TO .....	7-13
ADDXFER_GRP_FROM .....	7-14
ADDXFER_GRP_TO .....	7-14
ADDXFER_RVC_FROM.....	7-15
ADDXFER_RVC_TO .....	7-15
ADDXFER_TBL_FROM.....	7-15
ADDXFER_TBL_TO .....	7-16
APPLICATIONNAME.....	7-16
AUTHEMP.....	7-17
AUTHEMP_FNAME.....	7-17
AUTHEMP_LNAME.....	7-17
AUTHTYPE .....	7-18
AUTOSVC.....	7-18
AVAILABLEMEMORY.....	7-18
BOOTSERIALNUM.....	7-19
BOOTSERIALSTR.....	7-19
CASH_DRAWER.....	7-19

---

CENTER.....	7-20
CHANGE .....	7-20
CHECKDATA .....	7-21
CHGTIP.....	7-21
CHK.....	7-22
CHKINFOKEY .....	7-22
CHK_OPEN_TIME.....	7-23
CHK_OPEN_TIME_T.....	7-23
CHK_PAYMNT_TTL .....	7-23
CHK_TTL.....	7-23
CKCSHR.....	7-24
CKCSHR_NAME .....	7-24
CKEMP.....	7-24
CKEMP_CHKNAME .....	7-25
CKEMP_FNAME .....	7-25
CKEMP_CHKNAME .....	7-26
CKEMP_TYPEDEF .....	7-26
CKID .....	7-26
CKNUM .....	7-27
CLIENT_ONLINE .....	7-27
DAY .....	7-28
DAYOFWEEK .....	7-29
DBVERSION.....	7-29
DEBUGTRACE.....	7-29
DETAILSORTED.....	7-30
DSC .....	7-30
DSC_OVERRIDE.....	7-30
DSCI.....	7-31
DTLCHILDSELECTED .....	7-31
DTL_DEFSEQ.....	7-31
DTL_DETAILLINK .....	7-32
DTL_DSC_EMPL .....	7-32
DTL_DSCI.....	7-33
DTL_FAMGRP .....	7-33
DTL_INDEX .....	7-33
DTL_IS_COMBO.....	7-34
DTL_IS_COMBO_MAIN.....	7-34
DTL_IS_COMBO_SIDE.....	7-35
DTL_IS_COMBO_PARENT .....	7-35

---

DTL_IS_COND[i].....	7-35
DTL_IS_ON_HOLD .....	7-36
DTL_IS_VOID[i].....	7-36
DTL_MAJGRP.....	7-36
DTL_MLVL.....	7-37
DTL_NAME.....	7-37
DTL_OBJNUM .....	7-38
DTL_PLVL .....	7-38
DTL_PMSLINK.....	7-39
DTL_PRICESEQ.....	7-39
DTL_QTY .....	7-39
DTL_SEAT .....	7-40
DTLSELECTED .....	7-40
DTL_SLSI .....	7-41
DTL_SLVL .....	7-41
DTL_STATUS.....	7-41
DTL_SVC_LINK .....	7-42
DTL_SVC_TYPE.....	7-42
DTL_SVCI.....	7-43
Dtl_TaxTtl.....	7-43
DTL_TAXTYPE .....	7-43
DTL_TIMED_FIRE_TIME.....	7-44
DTL_TTL.....	7-44
DTL_TYPE .....	7-45
DTL_TYPEDEF.....	7-46
DWOFF.....	7-47
DWON.....	7-48
EMPLDISCOUNT .....	7-48
EMPLDISCOUNTEMPL .....	7-49
EMPLOPT .....	7-49
EPOCH.....	7-50
ERRORMESSAGE.....	7-50
EVENTARGUMENTS.....	7-50
EVENTID .....	7-51
EVENTNAME .....	7-51
EVENTTYPE.....	7-51
FIELDSTATUS .....	7-51
FILE.....	7-52
FILELINEMARKER.....	7-53

---

FILE_BFRSIZE.....	7-53
FILE_ERRNO.....	7-54
FILE_ERRSTR.....	7-55
FILE_SEPARATOR.....	7-56
FILTER_ACTIVE.....	7-56
FILTER_MASK.....	7-57
GRPNUM.....	7-57
GST.....	7-57
GSTRMNG.....	7-58
GSTTHISTENDER.....	7-59
GUID.....	7-60
HEADER.....	7-60
HOUR.....	7-60
IGNORE_PRMT.....	7-61
INEDITCLOSEDCHECK.....	7-61
INPUTSTATUS.....	7-61
INREOPENCLOSEDCHECK.....	7-62
INSTANDALONEMODE.....	7-62
ISJOURNALPRINT.....	7-63
ISUNICODE.....	7-63
JNL.....	7-63
KEY_CANCEL.....	7-64
KEY_CLEAR.....	7-65
KEY_DOWN_ARROW.....	7-65
KEY_ENTER.....	7-66
KEY_EXIT.....	7-66
KEY_HOME.....	7-67
KEY_LEFT_ARROW.....	7-67
KEY_PAGE_DOWN.....	7-67
KEY_PAGE_UP.....	7-68
KEY_RIGHT_ARROW.....	7-68
KEY_UP_ARROW.....	7-69
LANG_ID.....	7-69
LANG_NAME.....	7-69
LASTCKNUM.....	7-70
LINE.....	7-70
LINE_EXECUTED.....	7-70
MAGSTATUS.....	7-71
MAXDTLR.....	7-72

---

MAXDTLT .....	7-72
MAXKYBDMACRO .....	7-73
MAX_LINES_TO_RUN.....	7-73
MINUTE.....	7-73
MONTH .....	7-74
NEXTMYOPENCHECKGUID .....	7-74
NUL .....	7-74
NULL.....	7-75
NUMDSC .....	7-75
NUMDTLR .....	7-75
NUMDTLT.....	7-76
NUMLANGS .....	7-76
NUMOPENCHK.....	7-77
NUMSI.....	7-77
NUMSVC .....	7-77
NUMTAX.....	7-78
OBJ .....	7-78
OFFLINE LINK .....	7-78
OPNCHK_CKNUM .....	7-78
OPNCHK_TREMPID .....	7-79
OPNCHK_TREMPNUM.....	7-79
OPNCHK_WSID .....	7-80
OPNCHK_WSNUM .....	7-80
OPSCONTEXT .....	7-80
ORDERTYPE .....	7-81
OrderType_Name.....	7-81
ORDR.....	7-81
OS_PLATFORM.....	7-82
PICKUPLoAN .....	7-82
PLATFORM .....	7-83
PMSBUFFER.....	7-83
PMSLINK.....	7-83
PMSNUMBER .....	7-84
PREVPAY.....	7-85
PRINTSTATUS.....	7-85
PROPERTY .....	7-86
QTY .....	7-86
RANDOM.....	7-87
RCPT .....	7-87

---

REDOFF .....	7-87
REDON.....	7-88
RETURNSTATUS .....	7-89
RUNNINGDIRECTORY .....	7-89
RVC.....	7-89
RVC_NAME .....	7-90
RXMSG .....	7-90
SEAT .....	7-91
SECOND .....	7-91
SI.....	7-91
SI_DSC.....	7-92
SIMDBLINK .....	7-92
SRVPRD .....	7-92
STACKFRAMETEXT.....	7-93
STRINGARGS .....	7-93
SVC .....	7-93
SVCI.....	7-94
SYSLOGTRACE .....	7-94
SYSTEM_STATUS .....	7-94
TAX.....	7-95
TAXRATE .....	7-95
TAXVAT.....	7-96
TBLID .....	7-96
TBLNUM.....	7-96
TICKCOUNT .....	7-97
TMDNUM.....	7-97
TNDTTL .....	7-97
TOTALMEMORY .....	7-98
TRACE.....	7-99
TRAILER .....	7-99
TRAININGMODE .....	7-99
TRCSHR.....	7-100
TRDTLR .....	7-100
TRDTLT.....	7-101
TREMP .....	7-102
TREMP_CHKNAME.....	7-103
TREMP_FNAME.....	7-103
TREMP_LNAME .....	7-103
TTL.....	7-104

TTLDUE .....	7-104
TXBL .....	7-104
TXEX_ACTIVE .....	7-105
USEDMEMORY .....	7-105
USERENTRY .....	7-105
VALD.....	7-106
VARIABLEFRAMETEXT.....	7-106
VERSION .....	7-106
VOIDSTATUS .....	7-107
WARNINGS_ARE_FATAL .....	7-107
WCOLS.....	7-108
WEEKDAY.....	7-108
WROWS .....	7-109
WSID.....	7-109
WSNUM.....	7-109
WSSUBTYPE.....	7-109
WSTYPE .....	7-110
YEAR .....	7-110
YEARDAY .....	7-111

**8 ISL Commands ..... 8-1**

Commands.....	8-1
Command Summary .....	8-1
File I/O Operations .....	8-1
Format Specifiers .....	8-1
ISL File Input/Output Commands.....	8-1
The FOpen Command .....	8-1
File I/O System Variables.....	8-2
Input/Output File Format .....	8-2
Using Format Specifiers .....	8-2
What is a Format Specifier? .....	8-3
Types of Format Specifiers .....	8-3
Output Specifiers .....	8-6
Examples of Specifiers.....	8-7
Using Input and Output Specifiers Together.....	8-10
Command Summary .....	8-10
ISL Command Reference .....	8-16
Beep .....	8-16
Break .....	8-17
Call .....	8-18

---

ClearArray .....	8-19
ClearChkInfo .....	8-20
ClearIsITs .....	8-21
ClearKybdMacro.....	8-21
ClearRearArea .....	8-22
ContinueOnCancel .....	8-22
Display .....	8-23
DisplayInput.....	8-24
DisplayInverse.....	8-26
Description.....	8-26
DisplayIsITs .....	8-28
DisplayMSInput .....	8-28
DisplayRearArea.....	8-30
DLLCall .....	8-31
DLLCall_cdecl.....	8-31
DLLCall_STDCall .....	8-31
DLLCallW .....	8-32
DLLFree.....	8-32
DLLLoad .....	8-32
ErrorBeep .....	8-32
ErrorMessage.....	8-33
Event...EndEvent.....	8-34
ExitCancel .....	8-39
ExitContinue.....	8-40
ExitOnCancel.....	8-41
ExitWithError .....	8-41
FClose .....	8-42
FGetFile .....	8-43
FLock .....	8-44
FOpen .....	8-46
For...EndFor .....	8-47
Forever...EndFor .....	8-49
Format .....	8-50
FormatBuffer .....	8-51
FormatQ .....	8-52
FPutFile .....	8-53
FRead .....	8-54
FReadBfr.....	8-56
FReadLn .....	8-57

---

FSeek.....	8-57
FWrite.....	8-60
FWriteBfr.....	8-61
FWriteLn.....	8-62
GetEnterOrClear.....	8-63
GetRxMsg.....	8-64
GetTime.....	8-64
If...Else[If]...EndIf.....	8-65
Input.....	8-67
InputKey.....	8-68
InfoMessage.....	8-70
LineFeed.....	8-70
ListDisplay.....	8-71
ListInput.....	8-72
ListInputEx.....	8-74
ListPrint.....	8-75
LoadDbKybdMacro.....	8-76
LoadKybdMacro.....	8-77
LowerCase.....	8-78
MakeAscii.....	8-79
MakeUnicode.....	8-79
Mid.....	8-80
MSleep.....	8-81
PopUpIsITs.....	8-81
PrintLine.....	8-82
PrintSimFeatures.....	8-84
Prompt.....	8-84
ProRate.....	8-85
[Retain/Discard]GlobalVar.....	8-87
Return.....	8-88
ReTxMsg.....	8-89
RxMsg.....	8-89
SaveChkInfo.....	8-91
SaveRefInfo.....	8-93
SaveRefInfox.....	8-95
SetIsITsKey.....	8-96
SetReRead.....	8-98
SetSignOn[Left/Right].....	8-98
SetString.....	8-99

Split.....	8-100
SplitQ.....	8-101
StartPrint...EndPrint[FF/NOFF] .....	8-102
Sub... EndSub.....	8-104
TimerSet, TimerReset, TimerResetAll.....	8-107
TxMsg.....	8-108
TxMsgOnly .....	8-109
UpperCase .....	8-110
UseBackupTender.....	8-110
Use[Compat/ISL]Format.....	8-110
Use[ISL/STD]TimeOuts.....	8-111
UseSortedDetail .....	8-111
UseStdDetail .....	8-112
Var.....	8-112
WaitForClear .....	8-114
WaitForConfirm.....	8-115
WaitForEnter .....	8-116
WaitForRxMsg .....	8-117
WaitPrompt/ClearWaitPrompt.....	8-118
While...EndWhile .....	8-119
Window.....	8-120
WindowClose .....	8-121
Window[Edit/Input][WithSave] .....	8-122

**9 ISL Functions..... 9-1**

Functions.....	9-1
Function Summary .....	9-1
ISL Function Reference.....	9-2
Abs Function.....	9-3
ArraySize Function.....	9-3
Asc Function.....	9-4
Bit Function.....	9-4
Chr Function.....	9-5
CommandExists Function.....	9-6
DefKey Function .....	9-6
Env Function.....	9-6
Feof Function.....	9-7
FormatCheckData Function .....	9-7
FormatCurrentDate Function.....	9-8
FormatDate Function.....	9-8

---

FormatStr Function.....	9-8
FormatValue Function .....	9-9
FTell Function.....	9-9
FunctionExists .....	9-10
GetHex Function .....	9-10
GetValue Function.....	9-11
Instr Function .....	9-12
Key Function.....	9-12
KeyNumber Function.....	9-13
KeyType Function.....	9-13
Len Function.....	9-14
Mid Function .....	9-15
SplitString Function.....	9-16
Str Function.....	9-16
SystemVariableExists Function.....	9-17
ToInteger Function .....	9-17
Trim Function.....	9-17
TypeOf Function .....	9-18
VarExists Function.....	9-18
VarSize Function.....	9-19

**10 Android Barcode Scanner..... 10-1**

Overview .....	10-1
Subscribing to Barcode Scanner Events.....	10-1
Consuming Barcode Scanner Events.....	10-1
Barcode Scanner Event Args .....	10-1
Limitations .....	10-2
Barcode Scanner Objects .....	10-2
Barcode Formats .....	10-3
Barcode Types .....	10-3
Sample SIM Script.....	10-4

**11 Android NFC Support..... 11-1**

Overview .....	11-1
Subscribing to NFC Events.....	11-1
Consuming NFC Events .....	11-1
NFC Event Args .....	11-2
Limitations .....	11-2
Sundry SIM Features .....	11-2
Android NFC Objects.....	11-3

SIMByteList.....	11-5
SIM Custom HTML Dialog Asynchronous Data .....	11-6
Sample SIM Script Application with Custom HTML Dialogs.....	11-7

**Appendix A - ISL Error Messages..... A-1**

Error Message Format .....	A-1
Variable Descriptions .....	A-1
Format 1 .....	A-1
Format 2 .....	A-1
Format 3 .....	A-2
Format 4 .....	A-2
Format 5 .....	A-2
Error Messages .....	A-2
Array Index Out Of Range .....	A-2
Bad Sys Var Index.....	A-3
Break with Too Many Endfor.....	A-3
Break without Endfor.....	A-3
Call Has No Arguments.....	A-3
Can Not Evaluate .....	A-3
Cannot Access ISL Script File.....	A-3
Command Outside Procedure .....	A-3
Decimal Overflow.....	A-4
Display Column or Row Out Of Range.....	A-4
Divide by Zero .....	A-4
Duplicate variable Def.....	A-4
Encountered Non-Hex Data.....	A-4
Endsub Nesting Mismatch .....	A-5
Evaluation Nesting.....	A-5
Event Inside Procedure .....	A-5
Event Type Must Be Word .....	A-5
Exceeded Max Array or Variable Size .....	A-5
Expected Array in Call.....	A-5
Expected ..., Encountered.....	A-5
A-Expected Decimal .....	A-6
Expected End of Line.....	A-6
Expected Format Token .....	A-6
Expected Operand .....	A-6
Expected String .....	A-6
File Buffer Overflow .....	A-6
File is Read Only .....	A-6

---

File is Write Only .....	A-7
File Name Too Long .....	A-7
Format Needs String.....	A-7
Format Too Long.....	A-7
Integer Overflow .....	A-7
Invalid Decimal Operation .....	A-7
Invalid File Buffer Size .....	A-7
Invalid File Mode.....	A-7
Invalid File Number .....	A-8
Invalid First Token.....	A-8
Invalid Input fmt Spec.....	A-8
Invalid List Size.....	A-8
Invalid Locking Mode .....	A-8
Invalid Output Format.....	A-8
Invalid PMS SEND .....	A-8
Length Invalid.....	A-8
List Value Too Big.....	A-8
Loop Variable Constant .....	A-9
Loop Variable Not INT .....	A-9
Max Files Open.....	A-9
Max Include Nesting .....	A-9
Max Lines Executed.....	A-9
Max Macro Keys .....	A-9
Max Ref Info .....	A-9
Max Window Input Entries .....	A-9
Memory Allocation.....	A-9
Must Have List Var.....	A-10
Name is a Reserved Word .....	A-10
New TNDTTL Exceeds Original.....	A-10
No Arrays in Sub Var .....	A-10
No ISL File .....	A-10
No Match for EndFor .....	A-10
No Match for EndWhile.....	A-10
No Match for Event .....	A-11
No Number in Sys Var .....	A-11
No Ops on Strings.....	A-11
No PMS Message Received .....	A-11
No Touchscreen Keys Defined.....	A-11
Not a Variable.....	A-11

---

Not Enough Input Data .....	A-11
Not Enough List Data.....	A-12
Not Enough Variables .....	A-12
NUMERIC ENTRY REQUIRED.....	A-12
Print Already Started.....	A-12
Print Not Started .....	A-12
Reading Ord Dvc Table.....	A-12
Reading Tbl Def .....	A-13
Require Array for List .....	A-13
Script Memory Allocation Error .....	A-13
Start Position Invalid .....	A-13
String Overflow.....	A-13
Sub Array Ref Invalid.....	A-13
Sub Has No Arguments .....	A-13
Sub Statement in Procedure .....	A-13
System Variable Declaration .....	A-14
Sys Var Not Assignable.....	A-14
Too Few Args in Call.....	A-14
Too Few Arguments .....	A-14
Too many Args in Call .....	A-14
Too Many Arguments .....	A-14
Too Many Nested Calls.....	A-14
Too Many Touchscreen Keys .....	A-14
Too Many PMS Definitions Active. Start New Transaction.....	A-15
Undefined Call .....	A-15
Undefined Function.....	A-15
Undisplayable Variable.....	A-15
Unexpected Data after Call.....	A-15
Unexpected Data after Sub .....	A-15
Unexpected Data in Sub.....	A-15
Unexpected End of Line.....	A-15
Unexpected Token Type .....	A-15
Unknown Command.....	A-16
Unknown System Variable .....	A-16
Unmatched Endevent.....	A-16
Unmatched EndFor .....	A-16
Unmatched If .....	A-16
Value Not Key Definition .....	A-16
Variable Undefined .....	A-16

---

Window Columns Out of Range .....	A-16
Window Has Not Been Defined .....	A-16
Window Rows Out of Range.....	A-16
<b>Appendix B - Sample Code .....</b>	<b>B-1</b>
Oracle Resturants SIM TCP Server .....	B-1
Sample SIM Server.....	B-8
Sample Makefile.....	B-8
<b>Appendix C - ISL Quick Reference.....</b>	<b>C-1</b>
Data Types .....	C-1
Relational and Logical Operators .....	C-2
Unary Operators .....	C-2
Binary Operators.....	C-2
C-System Variables.....	C-3
Format Specifiers.....	C-9
Input Specifiers .....	C-9
Output Specifiers .....	C-9
Commands.....	C-10
Functions .....	C-17
<b>Appendix D - Windows DLL Access .....</b>	<b>D-1</b>
Windows DLL Access .....	D-1
Overview .....	D-1
What is a DLL? .....	D-1
Using DLLs .....	D-2
Simphony SIM DLL Support.....	D-2
Using Simphony SIM DLL Commands .....	D-3
Parameter Passing.....	D-4
Integers.....	D-6
Strings.....	D-7
Monetary Data.....	D-8
Array References.....	D-8
DLL Error Messages .....	D-9
General Error Messages .....	D-9
DLLCall Error Messages .....	D-10
DLLFree Error Messages.....	D-10
<b>Appendix E - SIM Events .....</b>	<b>E-1</b>
Overview .....	E-1
Events Directly Triggered by a Keystroke.....	E-1
Events Indirectly Triggered by an Ops Event.....	E-1

---

Event-Specific Variables.....	E-1
Quick Reference Table.....	E-2
SIM Confirm Events .....	E-6
<b>Appendix F - Stack Trace .....</b>	<b>F-1</b>
<b>Appendix G - SIM.net.....</b>	<b>G-1</b>
<b>Appendix H - Glossary.....</b>	<b>H-1</b>
Argument.....	H-1
Array.....	H-1
Asynchronous Serial Interface .....	H-1
Concatenate.....	H-1
Constant .....	H-1
Equation .....	H-1
Expression.....	H-1
Format Specifiers.....	H-2
Formula .....	H-2
Function.....	H-2
Global Command .....	H-2
Global Variable.....	H-3
Hex Expression.....	H-3
Input Expression .....	H-3
Integer.....	H-3
Interface Script Language (ISL).....	H-3
ISL .....	H-3
Language Element .....	H-3
Local Command .....	H-4
Local Variable.....	H-4
Nesting .....	H-4
Null String.....	H-4
Number of Records.....	H-4
Numeric Expression .....	H-4
Offset.....	H-4
Operator .....	H-5
Script.....	H-5
SIM .....	H-5
String.....	H-5
String Expression .....	H-5
Subexpression.....	H-5
Subroutine.....	H-5

---

Syntax .....	H-5
System Interface Module .....	H-5
System Variable .....	H-6
Token .....	H-6
Token Error .....	H-6
TTY .....	H-6
User Variable .....	H-6
Variable .....	H-6

---

---

# Tables

Table 1 Abbreviations.....	1-1
Table 2 Conventions .....	1-1
Table 3 Language Element Chapter Navigation.....	2-2
Table 4 POS Source ID Format .....	3-2
Table 5 Application_Sequence Format.....	3-3
Table 6 Checksum Format .....	3-4
Table 7 Correct and Incorrect Use of Whitespaces .....	4-6
Table 8 Examples of Where Whitespaces Increase Program Readability.....	4-7
Table 9 Data Types and Corresponding Abbreviations.....	5-2
Table 10 Unary Operators.....	5-3
Table 11 Binary Operators .....	5-4
Table 12 Example Variable Assignment .....	5-14
Table 13 ISL StartPrint Commands.....	6-2
Table 14 Printer System Variables .....	6-3
Table 15 Print Type System Variables.....	6-4
Table 16 System Variable Summary .....	7-4
Table 17 Item Detail Types.....	7-45
Table 18 Detail Types and Corresponding Sizes .....	7-46
Table 19 Input Status Flags.....	7-52
Table 20 Common Non-Zero Error Codes Returned by ISL File I/O Commands.....	7-54
Table 21 Possible Errors Received by the File I/O Commands .....	7-54
Table 22 User Input Status Flags.....	7-62
Table 23 Magnetic Card Entry Status Flag.....	7-71
Table 24 Values Corresponding to the Operating System Platform .....	7-82
Table 25 Print Status Flags .....	7-85
Table 26 Training Mode Status.....	7-100
Table 27 Transaction Detail Fields .....	7-101
Table 28 Input Specifier Placement Order .....	8-4
Table 29 M Input Specifier Format Fields.....	8-4
Table 30 Track 1 Field Positions of Credit Cards .....	8-5
Table 31 Track 2 Field Positions of Credit Cards.....	8-5
Table 32 Standard Field Position for Magnetic Employee Card.....	8-6
Table 33 Commands for Output Types.....	8-6
Table 34 Output Specifier Placement Order .....	8-6
Table 35 Examples for Justification Specifiers.....	8-7
Table 36 Examples for *Specifier .....	8-8
Table 37 Examples for + Specifier .....	8-8
Table 38 Examples for 0 Specifier .....	8-8
Table 39 Examples for 0 Specifier .....	8-9
Table 40 Examples for D, X, O, and B Specifiers.....	8-9
Table 41 Example 1 for: format_string Specifier .....	8-10
Table 42 Example 2 for :format_string Specifier .....	8-10
Table 43 Commands that Require a StartPrint or a Window Command .....	8-11
Table 44 Call Command Arguments .....	8-18

---

Table 45 ClearArray Command Arguments .....	8-19
Table 46 Display Command Arguments .....	8-23
Table 47 DisplayInput Command Arguments.....	8-25
Table 48 Display Inverse Command Arguments.....	8-27
Table 49 DisplayMSInout Command Arguments .....	8-29
Table 50 Error Message Command Arguments.....	8-33
Table 51 Event Inq Command Arguments .....	8-34
Table 52 Event Tmed Command Arguments.....	8-35
Table 53 Event RxMsg Command Arguments.....	8-36
Table 54 Event Print_Header and Event Print_Trailer Command Arguments.....	8-38
Table 55 ExitWithError Command Arguments .....	8-42
Table 56 FClose Command Arguments .....	8-42
Table 57 FGetFile Command Arguments .....	8-43
Table 58 Flock Command Arguments.....	8-44
Table 59 FOpen Command Arguments .....	8-46
Table 60 For...EndFor Command Arguments .....	8-48
Table 61 Format Command Arguments .....	8-50
Table 62 FormatBuffer Command Arguments .....	8-52
Table 63 FormatQ Command Arguments .....	8-52
Table 64 FPutFile Command Arguments .....	8-53
Table 65 FRead Command Arguments.....	8-55
Table 66 FReadBr Command Arguments.....	8-56
Table 67 FReadLn Command Arguments .....	8-57
Table 68 FSeek Command Arguments.....	8-58
Table 69 FUnLock Command Arguments.....	8-59
Table 70 FWrite Command Arguments .....	8-60
Table 71 FWrite Command Arguments .....	8-61
Table 72 FWriteLn Command Arguments .....	8-63
Table 73 GetEnterOrClear Command Arguments .....	8-63
Table 74 If...Else[If]...EndIf Command Arguments .....	8-66
Table 75 Input Command Arguments .....	8-67
Table 76 InputKey Command Arguments .....	8-69
Table 77 InfoMessage Command Arguments.....	8-70
Table 78 LineFeed Command Arguments.....	8-71
<b>Table 79 ListDisplay Command Arguments.....</b>	<b>8-72</b>
Table 80 ListInput Command Arguments.....	8-73
Table 81 List Print Command Arguments.....	8-75
Table 82 LoadDbKybdMacro Command Arguments.....	8-76
<b>Table 83 LoadKybdMacro Command Arguments.....</b>	<b>8-77</b>
Table 84 LowerCase Command Arguments .....	8-78
Table 85 MakeAscii Command Arguments .....	8-79
Table 86 MakeUnicode Command Arguments .....	8-79
Table 87 Mid Command Arguments.....	8-80
Table 88 PrintLine Command Arguments.....	8-82
Table 89 Prompt Command Arguments.....	8-85
Table 90 RxMsg Command Arguments.....	8-89
Table 91 SaveChkInfo Command Arguments .....	8-91
Table 92 SaveRefInfo Command Arguments.....	8-94

---

Table 93 SaveRefInfox Command Arguments.....	8-95
Table 94 SetIsTSKey Argument.....	8-96
Table 95 SetString Command Argument.....	8-99
Table 96 Split Command Argument.....	8-100
Table 97 SplitQ Command Arguments.....	8-101
Table 98 StartPrint...EndPrint[FF/NOFF] Command Arguments .....	8-102
Table 99 ISL Printer System Variables for StartPrint...EndPrint[FF/NOFF].....	8-102
Table 100 Sub...EndSub Command Arguments.....	8-104
Table 101 TxMsg Command Arguments.....	8-108
Table 102 TxMsgOnly Command Arguments .....	8-109
Table 103 UpperCase Command Arguments .....	8-110
Table 104 Var Command Argument .....	8-112
Table 105 Type Specifiers for User-Defined Variables.....	8-113
Table 106 WaitForClear Command Arguments .....	8-114
Table 107 WaitForConfirm Command Arguments.....	8-115
Table 108 WaitForEnter Command Arguments .....	8-117
Table 109 WaitForRxMsg Command Arguments .....	8-118
Table 110 While...EndWhile Command Arguments.....	8-119
Table 111 Window Command Arguments.....	8-120
Table 112 ISL Function Summary .....	9-1
Table 113 Abs Function Arguments .....	9-3
Table 114 ArraySize Function Arguments.....	9-3
Table 115 Asc Function Arguments.....	9-4
Table 116 Bit Function Arguments .....	9-4
Table 117 Example Bit Positions for a four Digit Hexadecimal Number .....	9-5
Table 118 Chr Function Arguments.....	9-5
Table 119 Abs Function Arguments .....	9-6
Table 120 Env Function Arguments .....	9-6
Table 121 Feof Function Arguments.....	9-7
Table 122 Abs Function Arguments .....	9-7
Table 123 Abs Function Arguments .....	9-8
Table 124 Abs Function Arguments .....	9-8
Table 125 Abs Function Arguments .....	9-9
Table 126 Abs Function Arguments .....	9-9
Table 127 FTell Function Arguments .....	9-9
Table 128 Abs Function Arguments .....	9-10
Table 129 GetHex Function Arguments.....	9-11
Table 130 Abs Function Arguments .....	9-11
Table 131 Instr Function Arguments.....	9-12
Table 132 Key Function Arguments .....	9-12
Table 133 KeyNumber Function Arguments .....	9-13
Table 134 KeyType Function Arguments .....	9-14
Table 135 Len Function Arguments.....	9-14
Table 136 Mid Function Arguments.....	9-15
Table 137 Abs Function Arguments .....	9-16
Table 138 Abs Function Arguments .....	9-16
Table 139 Abs Function Arguments .....	9-17
Table 140 ToInteger Function Arguments .....	9-17

---

Table 141 Trim Function Arguments.....	9-18
Table 142 Abs Function Arguments .....	9-18
Table 143 Abs Function Arguments .....	9-18
Table 144 VarSize Function Arguments.....	9-19
Table 145 Data Types.....	C-1
Table 146 Unary Operators.....	D-2
Table 147 Binary Operators .....	D-2
Table 148 System Variables.....	D-3
Table 149 Format Specifiers .....	D-9
Table 150 Output Specifiers.....	D-10
Table 151 Commands .....	D-10
Table 152 Functions .....	D-17
Table 153 C Parameter Declaration.....	D-5
Table 154 SIM Type Mapping to C Declarartion .....	D-5
Table 155 SIM Events and Corresponding Variables.....	E-2

---

---

# Figures

Figure 1 Order Chit with Message.....	2-10
Figure 2 Sample Raffle Ticket.....	2-11
Figure 3 Example var Command .....	5-2
Figure 4 Example PMSLINK .....	7-84
Figure 5 Example PMSNUMBER.....	7-85
Figure 6 ISL Error Message Format 1 .....	A-1
Figure 7 ISL Error Message Format 2 .....	A-1
Figure 8 ISL Error Message Format 3 .....	A-2
Figure 9 ISL Error Message Format 4 .....	A-2
Figure 10 ISL Error Message Format 5 .....	A-2
Figure 11 SIM Exception .....	F-1

---

---

# Preface

This manual describes the System Interface Module (SIM) of Oracle Symphony and its proprietary Interface Script Language (ISL). This manual provides information needed to develop an interface that facilitates communications between Symphony and various third-party systems by learning how to write scripts in ISL.

## Audience

This document is intended for Symphony programmers, support personnel, and installers.

## Customer Support

To contact Oracle Customer Support, access the Customer Support Portal at: <https://iccp.custhelp.com>

When contacting Customer Support, please provide the following:

- Product version and program/module name
- Functional and technical description of the problem (include business impact)
- Detailed step-by-step instructions to re-create
- Exact error message received and any associated log files
- Screen shots of each step you take

## Documentation

Product documentation is available on the Oracle Help Center at: <https://docs.oracle.com/en/industries/food-beverage/pos.html>

## Revision History

Date	Description of Change
September 2025	<ul style="list-style-type: none"><li>• Initial publication.</li></ul>



---

---

# 1 Before You Start

You must know:

- How to program high-level languages, such as BASIC or C/C++
- How to implement an interface
- How to program a Symphony database

## Abbreviations, Conventions, and Symbols

This section describes the abbreviations, conventions, and symbols that are used throughout this manual.

### Abbreviations

Certain phrases, as listed below, are abbreviated to make reading easier.

**Table 1 Abbreviations**

<b>This abbreviation...</b>	<b>Refers to...</b>
Interface	A software interface developed by a third party for the purpose of facilitating communications with Symphony
Operator	Anyone operating an Oracle workstation, including employees, cashiers, managers, servers
System	Oracle Symphony
Third-party System	Any other system interfacing with Symphony

### Conventions

The typographic conventions explained below help to simplify the written instructions.

**Table 2 Conventions**

<b>This Typographic Convention...</b>	<b>Described as...</b>	<b>Which is Used to Denote...</b>	<b>Is Shown In The Following Example(s)...</b>
. . . . . .	Three dots in a column	That part of a program or script has been intentionally omitted	Startprint . . . Endprint

This Typographic Convention...	Described as...	Which is Used to Denote...	Is Shown In The Following Example(s)...
	The pipe symbol	A list of options where only one option may be selected Note that a pipe is not allowed within an ISL command or function syntax.	[GE   LE   GT   LT]
__H	An alphanumeric string with an "H" suffix	Hexadecimal numbers	30H
<b>boldface</b> or <b>BoldFace</b>	Words appearing in a bold type font	<ul style="list-style-type: none"> <li>• Commands or functions that are the focus of the discussion</li> <li>• Items that must be entered exactly as they appear</li> </ul>	<b>cleararray</b> kitchen_msg  <b>DbResetTtls</b> (UINT...)
	Boldface words with mixed uppercase and lowercase letters and no spaces	Function and command names	<b>GetHex</b> <b>WindowClose</b>
Ellipses...	Three dots following a word or word series	That similar elements may follow	[,prompt_expression. ..]
[keys]	A keyname inside brackets	Keys on a PC or workstation keyboard	[Enter]  [Tab]

<b>This Typographic Convention...</b>	<b>Described as...</b>	<b>Which is Used to Denote...</b>	<b>Is Shown In The Following Example(s)...</b>
Placeholder or [placeholder]	Italicized words  Italicized words between brackets	Information the user must supply information the user must supply, but WITHOUT the brackets	<i>ResetType,</i> <i>expression, file_num</i>  [ <i>expression</i> ]
"Prompts"	Words or phrases in quotes	Prompts, text strings, and chapter names	"Press Enter to confirm"  "MM/DD/YY"
text	A non- proportional font	Code, program output, and error messages	cleararray kitchen_msg
under_score	An underlined space appearing between words	Argument names made up of two or more connected words	ver_rsp kitchen_msg
UPPER CASE	Words shown in all capital letters	Modules, fieldnames, type definitions, system variables, messages, and certain key words	27FLEDEF.H @CHK_OPEN_TIM E EMPL_DEF SECOND LAST_CHK_NUM



---

---

## 2 Understanding the SIM and ISL

This chapter contains an overview of the System Interface Module (SIM) and the Interface Script Language (ISL).

### Getting to Know the SIM and ISL

SIM extends the standard operation and functionality of Symphony through the Oracle Restaurants proprietary Interface Script Language (ISL). The SIM and ISL work together to provide establishments with the capability to enhance daily operations quickly and easily.

This section introduces SIM and ISL and explains how the module and script language work together.

#### What is the System Interface Module?

SIM is a component of the Symphony POS which allows third parties to customize and enhance the functionality of the POS. Like browser plug-ins or spreadsheet macros, SIM consists of a programming language (ISL) and an operating environment. SIM scripts can:

1. Hook into system events such as “begin check” or “transaction cancel” and perform custom processing.
2. Respond to custom user-programmed keypresses.
3. Access POS data such as check detail, the local configuration database, and various state variables such as current employee information.
4. Utilize POS functionality such as printing, display prompting and dialogs, interfacing with third-party systems, and disk I/O.

#### What is the Interface Script Language?

The ISL is a proprietary Oracle Restaurants interpreted language used to create small programs, called scripts. These scripts contain instructions that tell the SIM what to do. The ISL includes easy-to-learn, easy-to-use language elements, including a repertory of commands, functions, and system variables, as well as simple statement formats. Users manipulate these language elements to create instructions that are executed when the script is run.

Users with programming experience and familiarity with script writing will quickly adapt to the ISL. Although ISL is designed for use by systems developers, POS installers, and MIS staff, users with a strong knowledge of programming concepts and building blocks will also find the ISL easy to access.

#### Characteristics of the ISL

##### Like BASIC

ISL closely resembles BASIC (or variants) in its structured, linear structure. Scripts flow in a step-by-step structure, but unlike BASIC, each line of the script does not need to be numbered. Like BASIC and other structured languages, the ISL supports decision-

---

making language elements such as **If...Else**, and loop constructs using the **For...EndFor** and **Forever...EndFor**.

### Language Elements and Components

A myriad of language elements, common to most interpreted languages, comprise the ISL to help build SIM applications. Among the language elements comprising the ISL are **commands, functions, system variables, operators, and format specifiers**. All these elements are used in script writing.

Numerous **commands** comprise the foundation of the ISL, allowing the designer to:

- Control the flow of instructions in the script
- Define and manipulate variable information
- Facilitate communications between a third-party system and Symphony
- Process input and output
- Handle a variety of file processing operations
- Send data to print devices

ISL **functions** enhance text handling and formatting facilities.

These additional elements are also provided:

- **System variables**, for reading selected definition and totals information from the database and setting certain system parameters
- **Operators**, relational and logical (Boolean), that perform mathematical actions on variable and constant operands
- **Format specifiers**, which when used with commands, allow the specification of the format of input and output data where permitted

For detailed descriptions about each component of a specific language element, refer to the chapters listed below.

**Table 3 Language Element Chapter Navigation**

Language Element	Where to Go
Commands	See <a href="#">ISL Commands</a>
Functions	See <a href="#">ISL Functions</a>
System Variables	See <a href="#">ISL System Variables</a>
Operators	See <a href="#">Using Variables</a>
Format Specifiers	See <a href="#">Using Format Specifiers</a>

### Event Procedures

ISL is event oriented. An event procedure is a group of statements and commands that is defined by the ISL **Event...EndEvent** commands. The scripts provide a frame-like structure for a sequence of events.

To start an event, the event must be initiated with a specially programmed key or by a message response received from a third-party system. After an event is initiated successfully, the SIM stops processing the script until another event is initiated.

---

For example, the event shown below performs the following set of tasks:

- Displays an ISL-defined window on the screen of the workstation,
- Prompts an operator to enter a room number, and
- Sends the room number and the number of the Transaction Employee to a third-party system (for example, PMS).

```
event inq : 1                                // Execute when SIM Inquiry
key 1                                         //      is pressed
var room_num : N5                            // Declare
local variable window 2, 19, "Room Inquiry" //
Create input window display 2, 2, "Enter Room
Number"                                       // Issue
operator prompt input room_num, " "        // Accept
input
txmsg room_num, @trempt                      // Transmit room number and
Transaction                                  //      Employee to third-party
                                              //      system
waitforrxmsg                                 // Wait for response from
third-party endevent
```

- After the third-party system acknowledges receipt of the data, the event ends.

If the operator at the workstation initiates another event, the SIM begins processing the script again but until then, the SIM waits for the next instruction.

## Script Writing

### What is a Script File?

Scripts are small programs through which the ISL issues instructions to the SIM. A script is an ASCII text file that can be created in any common text editor, such as Microsoft Notepad. These scripts can contain one or more events to implement SIM applications.

A single script must be maintained for each SIM Interface defined for a system. The script is linked to a SIM Interface through Symphony database programming. Once this relationship has been formed through database programming, the script can be executed by Symphony. For specific programming requirements, refer to [Programming Symphony for SIM](#).

### Being Familiar with Script Writing...

Script writing is a common way to issue instructions to a computer. However, scripts written with the proprietary Oracle Restaurants ISL have a specific format and include elements unique to this language. Consequently, Oracle Restaurants recommends that users familiarize themselves with the unique language elements and script structure before writing the first script. Refer to [Script Writing Basics](#).

### Being New to Script Writing...

This manual also contains a brief introduction to this method of automating operations. If the programmer has never used scripts before, Oracle Restaurants recommends reviewing this introductory material. For further details, refer to [Script Writing Basics](#).

---

## How the ISL Accesses the SIM

The SIM can be accessed through instructions executed by a small program called a script, written with the Interface Script Language (ISL). Within a script, there may be several events, each defined to perform different tasks.

### Initiating an Event

Instructions within events in the script tell the SIM which tasks to perform. To carry out these instructions, the SIM first must be told to execute them. An event can be initiated within a script in one of the following three ways:

- The operator can press a **SIM Inquiry** key, programmed in the Symphony database to initiate an event.
- The operator can press a **SIM Tender** key, programmed in the Symphony database to initiate an event.
- A **third-party system**, interfaced with Symphony, can respond to a message sent to it by the SIM.

### Pressing a SIM Inquiry or Tender Key

When an operator at a workstation presses a SIM Inquiry or SIM Tender key:

- First, the SIM verifies certain required parameters within the Symphony database.
- After verifying that certain programming options and links are set up, the SIM searches for the script.
- After the SIM finds the correct script, it looks for a valid event, linked to the SIM Inquiry or SIM Tender key that the operator pressed to initiate the whole process.
- Finally, after locating a valid event, the SIM runs the script and executes the instructions contained in the event.

### Interfacing with a Third-party System

Several communications commands and system variables can be issued by events in the script. These commands and system variables can be used to send messages to a third-party system. In turn, the third-party system acknowledges these messages and responds over an interface method (for example, TTY or TCP/IP) using a message format recognized by Symphony. Message formats and interface methods supported by the SIM are described in [Message Formats and Interface Methods](#).

During this exchange, the SIM Interface acts as the go-between for both systems by shuttling the messages back and forth. A simplified version of the exchange goes like this:

- Symphony transmits a message to a third-party system with a **TxMsg** command statement in a script.
- The SIM Interface puts the message in a format that is acceptable to the third-party system.
- Then, the third-party system acknowledges the message and sends back a response, such as data requested by the SIM.

- 
- The SIM Interface forwards the response to Symphony in a message format acceptable to the POS: either fixed format or ISL format.

## Features of the SIM

The SIM provides a variety of features to help create functional and useful SIM applications with the ISL. The main features of the SIM include support for:

- Common communications message formats and interface methods for development of SIM Interfaces
- A variety of methods of displaying, capturing, and printing information
- The standard communications protocol that is required to interface with a third-party system, such as a PMS or delivery system
- Comprehensive file I/O processing operations

### Message Formats and Interface Methods

The ISL handles two types of message formats for developing a SIM Interface: **fixed format** and **ISL format**. Both message formats can be sent over two different interface methods, including an **asynchronous serial interface** (Host TTY ports) and **TCP-based interface**.

A discussion of both message formats and interface methods is in [Message Formats and Interface Methods](#).

### Methods of Displaying, Capturing, and Printing Data

Processing input and output, as well as printing data, are the mainstay of most POS transactions. Consequently, the SIM handles a variety of input and output operations. For displaying data, the Liquid Crystal Display (LCD) of a workstation is used as the platform for screen output.

Input data can be captured with the use of a touchscreen, a PC keyboard, a barcode reader, or a magnetic card reader.

The SIM controls printing with a versatile set of print commands and system variables, also called print directives.

### Data Entry

The entry of data is accepted from a PC keyboard, a touchscreen, a barcode reader, or a magnetic card reader. Generally, scripts that instruct an operator to collect data, such as name and address information, require entry using one of these methods.

#### Touchscreen

Data entry from a touchscreen is accepted, when required by the SIM during the execution of a script.

To support data entry from the touchscreen, the ISL includes commands for displaying a programmed or ISL-defined touchscreen when one is required. Normally, the script should display a touchscreen in order for the operator to select data from it. The data could be menu items, in which case the script should pop up a sales transaction type

---

touchscreen. Or the script could direct the operator to enter the customer's name, in which case, an alpha touchscreen should pop up for the operator to use.

### **Magnetic Card Reader**

The SIM can also access data that can be stored as track data on a magnetic card. Usually, track data includes the cardholder's name, a reference number, such as a credit card account number, and an expiration date. For example, the account number of a country club member could be stored as track data, allowing the operator to capture it from the POS by swiping the member's card through the magnetic card reader.

### **Printing**

Printing and backup printing are accomplished by the ISL using several ISL commands and a variety of ISL system variables.

### **Print Commands and Print Directives**

Print commands start print jobs, while the system variables—also called print directives—change the print characteristics of generated text. The print directives change the print type, like the way standard parallel printer escape sequences work. For example, printing some text in red ink can be accomplished with a print directive.

### **Type of Printers Supported**

All output can be generated at roll printers and Kitchen Display Systems (KDS). For the WS4(+) only, the ISL accommodates printing to a laser or dot matrix printer that is connected to its parallel port and is configured for the Extended Line Printing option.

## **Interfacing with Third-party Systems**

Communications are handled by the SIM through a variety of commands that support the exchange of messages between a third-party system and Symphony.

The type of messages sent back and forth between these two systems typically includes blocks of data. For instance, the third-party system can be used as a repository for data, such as customer name and address information in a customer database. This data might be used by Symphony to verify information in the third-party database with information input from the POS side.

For Symphony to send and accept data from a third-party system, a SIM Interface must be developed and enabled using the interface methods supported by the SIM, and the messages must be put in a format accepted by the SIM.

## **ISL File Handling**

The ISL also supports file processing operations found in other programming languages. Files can be opened, and while open, read and write operations can be performed, and then the file closes. For example, an application at a country club may involve checking a file for a member account number, retrieving it, and adding it to a guest check. But, if the member's account number is not found in the file, this feature allows the ISL to assign an account number for the new member, with the next available account number in the file.

---

## Creating SIM Applications with the ISL

The ISL is the gateway to the SIM of the Symphony software. When the ISL is used correctly, this powerful script language can be harnessed to build useful and practical SIM applications for all types of POS environments, including restaurants, bars, hotels, country clubs, and so on.

### Benefits of SIM Applications

The impact of SIM applications on these POS environments is immediate, especially when used to make certain POS transactions and functions easier for operators to perform. Such applications have the added benefit of making Symphony easier and simpler to use, thus, improving overall customer service.

Equally important is the fact that creating SIM applications also enables the user to expand the capabilities of Symphony. These applications take Symphony beyond its traditional function and improve existing features. For example, guest charge posting could be made faster, using prompting, system messaging could be improved, and customers can be tracked through the collection of information, like names and addresses. Whether simple or complex, when implemented properly, these types of SIM applications can make the system a more powerful tool for users.

### Types of SIM Applications

Although SIM applications can emphasize a variety of features, the applications likely to be implemented might involve such features as:

- Collecting and saving data for future retrieval or tracking, such as tracking customer sales to generate coupons, as rewards or incentives for frequent diners
- Expediting certain POS operations, like automatically applying a discount to a guest check when certain conditions are met
- Communicating with a third-party system, such as a Pizza Delivery System
- Writing to and reading from files, as in the case of verifying input with information in a file stored on disk
- Printing and posting information to checks in ways that the system may not be programmed to do, such as generating messages with special instructions for kitchen staff

This section contains several real-world examples of SIM applications, implementing a combination of SIM features. These examples are provided to give an idea of the type of SIM applications that can be created with the ISL. Keep in mind that these are only examples, and implementations of similar SIM applications can vary.

### Generating Coupons for Customers

The collection of data, such as customer information, is easily handled by the SIM. Such data can be captured and used by a third-party delivery system, interfaced with Symphony, allowing the entry and recall of customer name and address information.

Since customer sales and other data can be tracked this way, the ISL makes it easy to develop SIM applications that create rewards for customers. Most common are rewards

---

in the form of coupons and other incentives. Customers redeem these coupons for cash, gifts, reduced purchase price, and so on.

### **Frequent Diners**

Customers who frequently patronize an establishment are often targeted to receive rewards and incentives for their continued loyalty. At the fictional restaurant, a Birthday Club is one of the incentive programs offered to frequent diners.

Assume that a third-party database exists with pertinent information about frequent diners, such as name, account number, birthdate, and so on, for sales tracking purposes. In addition, also assume that the restaurant issues frequent diners a special VIP card, including an account number and birthdate as track data<sup>1</sup>.

Whenever the frequent diner visits the restaurant, the diner must present the VIP card so the server can credit sales to the frequent diner's account.

### **Generating a Birthday Coupon**

A server generates a "Birthday Coupon" based on the information that the restaurant is tracking. The coupon is redeemable for a free appetizer upon the customer's next visit. At this restaurant, the Birthday Club works like this:

- Using the birthdate read by a magnetic card reader from the VIP card track data<sup>1</sup>, Symphony checks it against the current system date. If the birthdate is equal to the system date, then Symphony automatically issues a Birthday Coupon when the server closes the guest check.

When presenting the guest check, the server also gives the diner the Birthday Coupon.

---

<sup>1</sup> This term refers to information stored on the magnetic stripe of a credit card. The information is often stored on separate areas of the magnetic stripe, called tracks. For example, the account number and birthdate in this example are stored on Track 2 of the magnetic stripe.

---

## Interfacing with a Pizza Delivery System

One of the important features of the ISL is its ability to support an interface between Symphony and a third-party system. Such an interface allows both systems to communicate with each other by handling the exchange of messages between the systems.

For example, over a SIM Interface, Symphony captures customer information input on the POS side, and then the information is sent to the third-party delivery system. A SIM Interface enables the operator to retrieve this information from the delivery system's database as needed through a query or search.

### Guest Check Information Detail

Information that might be captured and stored in a third-party database includes the name and address information, the customer's telephone number, as well as directions to the customer's residence. When a customer telephones the pizzeria, an operator uses the customer's telephone number to access any existing information in the pizza delivery system's database.

As an added benefit, this SIM application also prints this customer information on the guest check. For example, the directions to the customer's residence prints on the check for the delivery person to reference.

### Previous Order History

In addition to name and address information, a customer's order history is also information that the third-party system maintains. By retrieving previous order history, the operator eliminates the additional steps required to post order information, namely menu items, to a guest check. If the customer always orders a large pepperoni and mushroom pizza, these items can be retrieved from the third-party database, and posted to the check, without directly accessing the menu item keys again. In a fast-paced environment like a pizza delivery operation, where quick turnaround is critical, eliminating steps in the order entry process is a real advantage.

## Collecting Customer Information for a Membership List

Many implementations of SIM applications collect data, such as name and address information or guest history. Collecting and storing this information can be retrieved for later use.

The ISL can be used to handle these functions in one of two ways, including:

- Use ISL file I/O capabilities to read from and write to files that are stored on the same PC running Symphony.
- Interface with a third-party system, as described in the pizza delivery system example, to send data to and retrieve it from another system.

Although both options enable the storage and retrieval data, the first option allows faster access data, because no communications overhead is involved.

### Reading Data from a File

One implementation of the file I/O option is to collect customer data and add it to a membership list, which is kept in a file. The application requires that an operator at a

---

country club, for example, enters name and address information in Symphony. Behind the scenes, the ISL opens the file and writes this new information to it, or verifies existing information, and then closes it.

The country club uses this file to verify membership information. For example, by reading this file, operators determine whether the customer's membership dues are current, or whether the member is entitled to certain privileges, such as running a tab at the country club's bar.

## Customizing Output

Printing is an essential POS function that can be expanded to accommodate the unique preferences of a property. Symphony comes equipped with many different programming options that affect how, where, and when things print. With the ISL, printing can be further customized for a property by extending the functionality of Symphony beyond its normal programmable limits.

The ISL's special printing abilities in the previous examples, such as printing customer information on guest checks and generating coupons for customers has been previously mentioned. Now let's examine how servers can save time when they must send special instructions to kitchen staff about orders.

## Sending Special Messages to the Kitchen

The SIM application allows an operator to select a message from a list, and then send the message to the kitchen. The list includes messages frequently sent to the kitchen, which is a feature that current programming options for number lookups (NLUs) do not support.

A remote roll printer in the kitchen generates the following message on a chit:

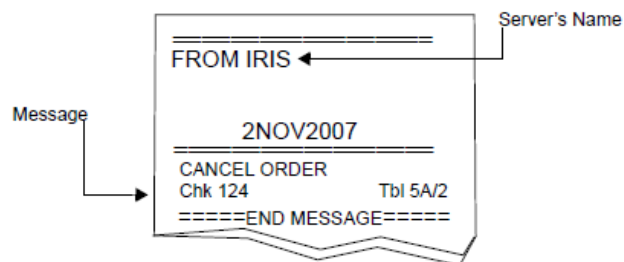

**Figure 1 Order Chit with Message**

## Creating Raffle Tickets

Another good example of using the special printing capabilities of the ISL is creating output other than guest checks, remote order chits, and customer receipts.

Earlier in this section we described how to generate a coupon with the ISL. Now, let's create a raffle ticket for hotel guests.

This application requires that Symphony interface with a PMS. The application performs a common PMS task: collecting a guest's name and room number when the operator closes a guest check in one of the hotel's food and beverage outlets.

For this application, the ISL verifies the input with data already stored in the PMS database. Based on how many times the guest has patronized the hotel's four-star restaurant, for example, a raffle ticket chit is generated after the guest check prints. The raffle ticket includes an excursion option, which was selected from a list of others, as well as the guest's name and room number. The ISL also automatically assigns a ticket number to the chit.

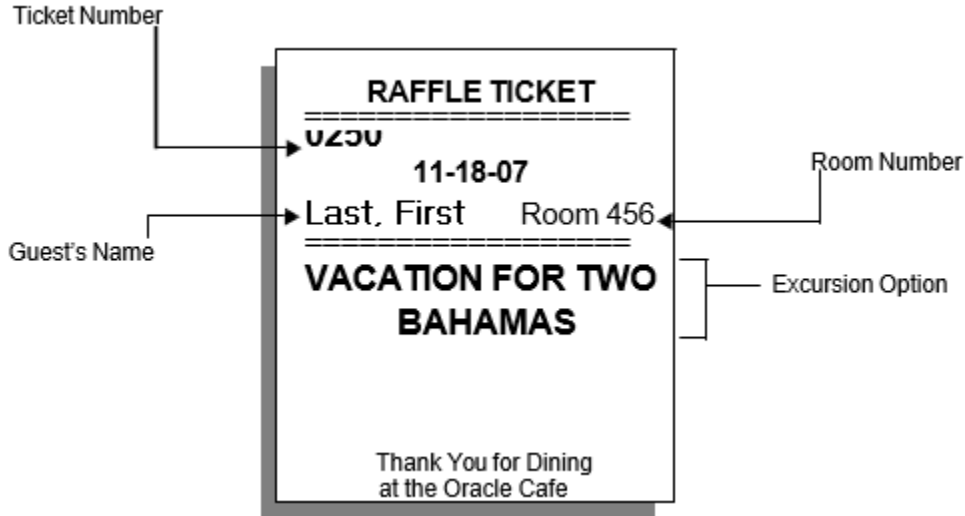

**Figure 2 Sample Raffle Ticket**

Such a chit cannot be generated by Symphony using current programming options. However, the ISL makes it possible to print output that is outside the traditional realm of a POS.



---

---

## 3 Getting Started

This chapter contains a description of the message formats and interface methods that must be used to develop a SIM Interface. It also includes a description of the Symphony database programming required to enable the SIM and a SIM Interface.

### Getting Started with the ISL and SIM

This chapter focuses on the steps that must be taken to implement the SIM applications successfully. In this chapter, the following is described:

- What communications message formats and interface methods are available for developing a SIM Interface
- How to enable the SIM and a SIM Interface

### Developing the SIM Interface

When creating SIM applications that require communication with a third-party system, such as a PMS or delivery system, a SIM Interface must be developed. This interface must utilize supported message formats and interface methods to facilitate communications between Symphony and the third-party system. In [Message Formats and Interface Methods](#), the message formats and interface methods to apply when creating the SIM Interface are discussed.

### Enabling SIM and a SIM Interface

Specific Symphony EMC configuration steps must be performed to enable the SIM and the SIM Interface to successfully execute scripts. Contact your Oracle Symphony implementation consultant to enable your SIM Interfaces and to review your associated SIM script configuration options.

## Message Formats and Interface Methods

To develop the SIM Interface, use the message formats and the interface methods described in this section.

### Message Formats

There are two classes of message format: fixed format and ISL format.

---

---

**Note:** Both formats over the same type of interface can be used. For example, the ISL format can be used over both a TTY- and a TCP-based SIM Interface.

---

---

### Fixed Message Format

Support for this message format allows a PMS compatible fixed-format message to communicate with Symphony through a SIM Interface. However, Oracle Restaurants recommends that the ISL message format be used unless fixed-format messages are a requirement of the third-party system.

---

This recommendation is made since the fixed content of this message format provides a limited set of information. For example, a fixed message must always contain four sales itemizers and four tax itemizers. If a PMS needs access to eight sale itemizers, this message format cannot be changed to accommodate eight sales itemizers. The ISL message format provides much more flexibility.

Consequently, the fixed message format should only be used in cases where the third-party system requires fixed-format style compatibility due to pre-existing PMS installations.

### Message Format

The format of the message is as follows:

SOH ID STX Data ETX Checksum EOT

### ISL Message Format

Messages defined using the ISL are structured like fixed messages, except that the *Data* segment of a fixed message is broken out into two segments in the ISL message: *Application\_Sequence* and *Application\_Data*.

However, the segments of the ISL message are enveloped using control characters. IBM PC character codes, an ASCII superset, provide support for international characters.

The format of the ISL message is as follows:

SOH ID STX FS *Application\_Sequence* *Application\_Data* ETX Checksum EOT

A description of each message segment follows.

### SOH

The SOH character (start of header) serves as a message lead-in character that identifies the start of a new message. The SOH character is represented by the 7-bit hexadecimal value 01H, plus a parity bit, if applicable.

### ID

This is the POS Source ID segment that includes information about the workstation. The workstation initiates the message and identifies the interface.

The format of this segment is as follows:

**Table 4 POS Source ID Format**

Field	Length	Format	Remarks
POS Workstation Number	9 Bytes	2 or 9 ASCII Digits	May contain leading spaces or zeroes and is between 1 and 999999999, depending on 2/9-digit ID in the Interface module. Standard interface format is 2 digits.
Interface Name	16 Bytes	16 ASCII Characters	Uses IBM PC character set.

---

## STX

The STX character (start of text) serves as a data field lead-in character that identifies the start of the message data block. The STX character is represented by the 7-bit hexadecimal value 02H, plus a parity bit, if applicable.

## FS

The FS character (field separator) identifies this message as a SIM message data block. The FS character is represented by the 7-bit hexadecimal value 1CH, plus a parity bit, if applicable.

## Application\_Sequence

The *Application\_Sequence* segment comprises a two-digit sequence number and a retransmission flag. Each POS workstation application increments its own sequence number with each message. When a message is being retransmitted, the same sequence number is used as in the original message. In addition, a retransmit flag character is provided.

The format of this segment is as follows:

**Table 5 Application\_Sequence Format**

Field	Length	Format	Remarks
Applications Sequence Number	2 Bytes	2 ASCII Digits	May contain leading spaces or zeroes and is between 00 and 99.
Retransmission Flag Character	1 Byte	Space or 'R'	'R' character (ASCII 52H) is placed in this field if this is a retransmitted message.

The *Application\_Sequence* number is initially set to "01" when the application starts. The application rolls the sequence number back to "01" after "99."

If the third-party system receives a message containing the same sequence number as the previous message and the retransmit flag is set, the third-party should retransmit the last response.

## Application\_Data

Both the TxMsg and RxMsg commands define the *Application\_Data* segment. The total size of the message can be 32K from the SOH to the EOT. There are a maximum of 37 bytes overhead, which means that the maximum byte count of all the fields and field separators is 32768 - 37, or 32731 bytes.

---

**Note:** When the asynchronous serial interface messages are not limited, it is recommended that they be no more than 1024 bytes in length, so that the interface remains responsive.

---

Multiple fields can comprise this segment. Individual fields within the *Application\_Data* segment are separated by the ASCII field separator character (1CH), inserted by the ISL.

---

In addition, the first field within the receive message *Application\_Data* segment defines the name of the ISL procedure to execute when processing the response message. The detail description of the **RxMsg** command describes the relationship between the command and the *Application\_Data* segment of an ISL message.

## ETX

The ETX character (end of text) serves as a data field lead-out character that identifies the end of the message data block. The ETX character is represented by the 7-bit hexadecimal value 03H, plus a parity bit, if applicable.

## Checksum

The *Checksum* field is only used when communicating over an asynchronous serial interface. A TCP-based SIM Interface ignores this field, so it can be omitted from the message format. When the *Checksum* is part of the message, however, format it as follows:

**Table 6 Checksum Format**

Field	Length	Format	Remarks
Checksum	4 Bytes	4 ASCII Hex characters	Contains ASCII characters in the range 30H - 39H and 41H - 46H (0-9 and A-F).

The *Checksum* is the 16-bit binary addition (excluding parity, if applicable) of all characters after the SOH, up to and including the ETX character. The *Checksum* is initially set to zero. For transmission, the *Checksum* is represented as four ASCII-Hex characters.

## EOT

The End of Transmission character (EOT) identifies the end of the message. It is represented by the hexadecimal value 04H, plus a parity bit, if applicable.

## Interface Methods

The SIM supports two types of interfaces: an asynchronous serial interface and a TCP-based interface. Both interface methods support the Symphony-compatibility fixed-format message and the ISL message format.

---

**Note:** Both the fixed and ISL formats can be used over the same interface and, because Symphony supports multiple interfaces per revenue center, any combination of these interfaces may be used within a revenue center.

---

## Asynchronous Serial Interface

This type of interface method supports communications with a third-party system over an Asynchronous Communications Adaptor (COM port) installed in the PC that controls Symphony.

---

This interface is widely used to implement a PMS Interface to facilitate communications between Symphony and a PMS. With the introduction of SIM, this interface method can also be a choice for implementing a SIM Interface.

### **Asynchronous Serial Interface Specifications**

Specifications for developing an asynchronous serial interface are defined in the *1700/2000/4700/8700 PMS Interface Specifications Manual*. Refer to this manual for more information about this type of interface method.

### **Configuring a TTY Interface in the Symphony Database**

If using this type of interface, the Enterprise Management Console (EMC) *Hardware Interface* module must be configured to enable the interface.

To enable a TTY interface:

1. Add an interface record.
2. Select TTY in the **Comm Type** field.
3. Enter the device name in the **Comms Name** field. For example, type:
  - `tty2a` (which represents the TTY device), or
  - `workstation` (which indicates that the workstation is directly connected to the PMS)
4. Select the appropriate number of digits for the interface by enabling or disabling this option: **ON = Use 9 digits for Terminal IDs; OFF = Use 2 Digits for Terminal IDs.**

### **TCP Interface**

This interface is designed to connect Symphony to Microsoft Windows®-based systems and other systems using the TCP/IP networking protocol. This interface can also be used to facilitate communications between the POS application and third-party applications that reside on the same Microsoft Windows platform as the Symphony software.

This interface is also compatible with many forms of local area networks (LANs), including Ethernet, Token Ring, FDDI, Arcnet, PPP, and so on.

### **Configuring a TCP Host in Symphony**

If using this type of interface, the Enterprise Management Console (EMC) *Hardware Interface* module must be configured to enable the interface.

To enable a TCP interface:

1. Add an interface record.
2. Select **TCP** in the **Comm Type** field.
3. Enter the **TCP Host Name**.
4. Select the appropriate number of digits for the interface by enabling or disabling this option: **ON = Use 9 digits for Terminal IDs; OFF = Use 2 Digits for Terminal IDs.**

### **TCP Connection**

The SIM connects to the TCP port as a client. The SIM Server should accept TCP connections from the Symphony POS workstation on the port "microsim." If this service is not defined, the port number 5009 should be used as the default.

---

### **Error-Handling**

If the receiving system detects an error in the message or some other applications-related error, it should provide an appropriate error message response to the POS application. In addition, if using the fixed message format, response messages should handle error messages. As such, to support these conditions, the ISL should define specific error responses.

### **Pinging**

The TCP connection has a typical “keep-alive” time-out of two hours. To detect a “down” interface more quickly and re-establish the connection, the SIM periodically sends a “ping” message to the server about every five minutes. The server should detect the ping message and return the message in its original format.

The format of the ping message should be as follows:

SOH *ID* STX ETX EOT

The *ID* source segment contains a null address: the POS workstation number will be zero and the interface name will contain spaces.

### **TCP Interface Code Example**

Several programming aides are provided in [TCP Interface Code](#). Two samples of code are provided to implement a TCP Interface: a SIM TCP Server and a SIM Server.

---

---

## 4 Script Writing Basics

For users who are new to script writing or need to familiarize themselves with script writing conventions, this chapter discusses basic script writing concepts to apply when creating scripts.

### Getting Started with Script Writing

This section introduces the process of script writing, a tool used to create SIM scripts.

This section provides the specific conventions and formats needed to write scripts with the ISL. This section also includes the information needed to begin using scripts for the first time.

Specifically, this chapter covers:

- What a script is
- Why use scripts
- Parts of a script
- How to write a script
- What is proper script writing style
- How to test a script

### What is a Script?

The means by which the ISL issues instructions to the SIM is through small programs known as scripts. A script is an ASCII text file that the programmer creates in any common text editor, such as Microsoft Windows® Notepad. These scripts can contain one or more events to implement SIM applications.

A separate script must be maintained for each SIM Interface defined for a system. The script is linked to a SIM Interface through Symphony database programming. Once this relationship is formed through database programming, the script can be executed by the SIM. For specific programming requirements, refer to [Programming Symphony for SIM](#).

### Structure of a Script

The basic structure of scripts should be written in a format like the sample script below. When writing the script, keep the following structure in mind. A brief description of each part follows the diagram.

<code>// This is a sample script.</code>	←	Comments
<code>var trans_type</code>	←	Global Variable Declaration
<code>event inq : 1</code>	←	Event Declaration
<code>var cnt : N3</code>	←	Local Variable Declaration
<code>window 2, 19</code>	←	Commands

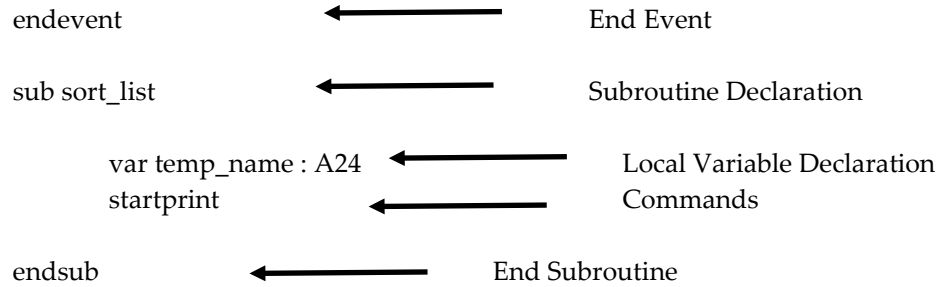

- **Comments:** Comments are used to document the purpose and scope of events included in the script. Place comments anywhere in the script, but make sure each comment line is preceded by two backslash characters “//” (see [Script Writing Style](#)).
- **Global variable declarations:** Global variables are initialized at the beginning of each script and maintained for the duration of the script.
- **Event declaration:** ISL is event oriented. Almost all ISL statements will be contained in events or subroutines, called by those events (see [Event...EndEvent](#)). There are five types of events:
  - **Event Inq:** This event executes when a SIM Inquiry key is used.
  - **Event Tmed:** This event is executed when a SIM Tender key is used.
  - **Event RxMsg:** This event is executed when a response is received from the third-party system.
  - **Event Final\_Tender:** This event is executed whenever the last tender event has occurred, but before a check has closed.
  - **Event Print\_Header and Print\_Trailer:** This event is executed whenever certain control characters are programmed in the *RVC Descriptors* module within the Enterprise Management Console (EMC).
- **Local variable declaration commands:** Local variables are purged after each event completes execution; the event terminates after an **EndEvent**, **ExitCancel**, **ExitContinue**, or any other command that causes the event to stop executing, successfully or not.
- **Subroutine declaration:** Subroutine procedures are called from other event or subroutine procedures, allowing common code to be used by multiple events. As a script writing convention, Oracle Restaurants recommends that all subroutines be placed after all events in the script. Subroutines are described on page 8-104.

## Creating Scripts

Scripts consist of one or more events. Each event within the script represents a task that the SIM should perform. For instance, Chapter 2 discusses several different types of SIM applications. Each of these applications can exist as separate events within the same script.

---

## Guidelines for Creating Scripts

When beginning to develop the SIM applications, use the guidelines below to create the script.

- Understand the tasks that the script will perform.
- Outline the structure of the script. In plain English, write down the steps needed to automate in each event. Carefully note each detail about the tasks that the event will accomplish.
- Write a brief description of the task that each event or subroutine performs. For future reference, this description should appear as a comment before each event and subroutine in the script.
- Note any input and output. Does the user enter data? Does a guest check or remote order chit need to be generated?
- Think about assumptions being made about the environment. For example, if the application applies a discount to a check total greater than or equal to \$50.00, test for this case in the script before applying the discount.
- Protect against the user. The event should not allow users to get stuck or to perform a task that they should not. For example, if input is requested from an operator and the operator gives incorrect input, then an error should be issued to force the operator to enter the requested information.
- Determine what variables (global, local) need to be declared. For a discussion of user variables, refer to [Using Variables](#).
- Determine whether some of the events in the script perform similar tasks. If they do, consider creating a subroutine to save time in writing the script and to make the script process instructions more efficiently.
- Translate the instructions written into one or more lines of code.
- Consult the ISL Quick Reference beginning on page 1 to determine what commands, functions, and system variables allow the desired task to be performed.
- Learn what considerations are involved in writing ISL statements. [Script Writing Style](#) covers these guidelines.
- Review the detail descriptions of the required language elements. The examples provided with detail descriptions can be helpful as templates from which ISL statements can be built.

## Examples of Scripts

### Charge Denial

This script places a window with the title “Charge Denied” on the screen and provides text in it with the reason why the charge was denied. The operator is then prompted to enter the [Clear] key before cancelling the operation.

```
event rxmsg : denial_msg
  var reason_text : a32

  rxmsg reason_text
  window 3, 34, "Charge Denied"
  display 2,@CENTER, reason_text
```

```

        waitforclear
        exitcancel
    endevent

```

## Charge Posting

This script posts a charge to a PMS system and waits for the response.

```

var guest_id:a20

event tmed : 1                                //PMS room charge key is
                                                // Tender key #1 input guest_id, "Guest
posting, enter name or room #" txmsg "CHG_POSTING", guest_id, @TNDTTL,
@CHKNUM,@RVC waitforrxmsg
endevent

event rxmsg : chg_posting
    var status : a1, message : a20, temp_tndttl : $12

    rxmsg status, message, temp_tndttl

    if status="P"                               //Posting approved
        saverefinfo message
        @TNDTTL = temp_tndttl
        exitcontinue
    endif

    if status = "D"                             //Charge declined. exitcancel message
    endif

    if status = "E"                             //Error exitwitherror message
    endif
endevent

```

## Address and Phone Number Entry

This example prompts the operator to enter a customer's address and phone number.

```

var phone_num : N7                            //Global variable, keep phone
                                                // number around.

event inq : 1                                  //Use Inquiry key #1 to get guest info.
    var cust_name : A32
    var addr1 : A32 var addr2 : A32 var addr3 : A32
    var special_instructions : A32

    window 7, 50, "Customer Info" display 2,2, "Phone Number:"
    displayinput 2, 18, phone_num{:###-####}, "Enter phone number" display 3,2,
    "Customer name:"
    displayinput 3,18,cust_name, "Enter customer's name" display 4,2, "Address
    Line 1:"
    displayinput 4,18,addr1, "Enter address" display 5,2, "Address Line 2:"
    displayinput 5,18,addr2, "Enter address" display 4,2, "Address Line 3:"
    displayinput 6,18,addr3, "Enter address" display 7,2, "Instructions:"
    displayinput 7,18,special_instructions, "Enter instructions"
    windowinput

    txmsg phone_num, cust_name, addr1, addr2, addr3, \
        special_instructions
    waitforrxMsg
endevent

event rxmsg : phone_num
    var phone_num : n10
    var status : a1

```

---

```

    rxmsg status, phone_num
    if status = "N"
        exitwitherror "Phone Number Not Found "
    endif
    window 3, 12
        display 2, @CENTER, phone_num
    waitforenter
endevent

```

## Script Writing Style

Before beginning to write the first script, review the style conventions in this section. For readability, apply these conventions in the script writing.

### Case

ISL statements are not case sensitive and the use of case in examples is purely for clarity and the author's choice of style. However, quoted strings are case sensitive.

### Length of Variables

The maximum character length for all variable names (user variables, subroutines, etc.) is 255.

### Comments (//)

Declarations and commands will always be on their own line and should be the first non-white space characters. A comment may be placed on a line by beginning the comment with "//" characters. All characters to the right of the comment identifier "//" are ignored. For example:

```

Window 2,19, "ROOM INQUIRY" //Create window
Display 2,2, "Enter Room Number" //Prompt for room number

```

A comment may reside on its own line or to the right of a command and its arguments. Lines should be terminated with an ASCII carriage return, or an ASCII line feed, or a carriage return/line feed pair.

### Continuation Lines (\)

A line continuation character "\" is provided to allow commands to continue from one line to the next. For example, a command that overflows several lines might be:

```
TxMsg field1, field2, field3, field4, \ field5, field6, field7, field8, field9
```

It is not possible to break apart a string with a line continuation character:

Correct:

```

errormessage "Choose a number between 1 ",\
            "and 10"

```

Incorrect:

```

errormessage "Choose a number between 1\
            and 10"

```

Line continuation characters may not be followed by comments or any other commands.

---

## Whitespace

Whitespace in ISL is defined as spaces or tab characters inserted into a program to either separate commands from their arguments or to improve program readability. For example, the programmer might find it easier to write:

```
numrow = ( ( ( num_guest - 1 ) * 2 ) + header )
```

Instead of:

```
numrow=(( (num_guest-1)*2)+header)
```

Whitespace can be placed anywhere in a script between two distinct language elements. Language elements are commands, functions, system variables, user-defined variables, input/output specifiers, comments (`//`), relational and boolean operators, and commas. A language element is an indivisible piece of information which, if broken apart with whitespace, will generate an ISL “token” error. For a complete listing of error messages, see [Appendix B](#).

For example, the number -125.99 cannot be written as - 125. 9 9. The command **WaitForClear** cannot be written as **Wait For Clear**.

The table below shows the incorrect and correct ways of using whitespace:

**Table 7 Correct and Incorrect Use of Whitespaces**

ISL Language	Incorrect Use of Whitespace	Correct Use of Whitespace
Within a variable name	num _ columns = 1	num_columns = 1
Within a command or function name	load ky bd macro 1:12	loadkybdmacro 1 : 12
Within a numeric value	- 19 8. 45	-198.45
Within a command format specifier	A 12 N 5 \$ 12	A12 N5 \$12
Within a comment delimiter	/ / comment...	// comment...
Within double-character relational operators	a < > b  count < = 5 Joe > = Richard	a<>b  count <= 5 Joe >= Richard
Between the @ and a System Variable name	@ TNDTTL @ YEAR	@TNDTTL @YEAR

---

The following table shows examples of where whitespace increases program readability:

**Table 8 Examples of Where Whitespaces Increase Program Readability**

No Whitespace	With Whitespace
<code>var count[10]:N5</code>	<code>var count[ 10 ] : N5</code>
<code>display 1,2,"Room is ",room</code>	<code>display 1, 2, "Room is ", room</code>
<code>txmsg "CHG",guest,@tndttl+1.00</code>	<code>txmsg "CHG", guest, @tndttl + 1.00</code>

## Writing and Editing Scripts

Scripts should be composed in an ASCII text file and saved with the appropriate file naming convention discussed in [Programming Symphony for SIM](#).

---

---

**Note:** There is no need to compile the script or process it in any other way before the SIM can read the script.

---

---

### Avoiding Errors

To avoid errors when writing and editing scripts, follow these basic guidelines:

- Verify that the script was named using the correct conventions (see page 4-5). Also make sure it is in the proper directory.
- Check the Symphony database programming.
- Review the structure of the script.
- Are all global variables declared at the beginning of the script?
- Within each event, have all local variables been declared before issuing the first command?
- Are the subroutines that are called in events also within the same script? Does the called subroutine have the same name as the actual subroutine?
- Look at the programming style. See [Script Writing Style](#).
- Check that events correspond to the correct SIM Inquiry or SIM Tender keys initiating the event or tender event, respectively. For further details about creating these keys, refer to [Programming Symphony for SIM](#).
- Check the script for syntax errors. Make sure that if a command has a corresponding command ending the task, include it. For example, the **Event** command must be used with the **EndEvent** command, which should always be the last line of an event procedure.

---

## Testing Scripts

Before using the SIM application in a live environment, Oracle Restaurants recommends testing it for errors first.

### Detecting Errors in Logic

When the script is run, any errors in syntax are detected by the SIM, and an ISL error message appears. However, some errors in logic may not be caught by running the script.

Scripts make no assumptions, so execute the instructions exactly as specified. It is possible to run a script and detect no syntax-errors, but still have problems with the logic. Therefore, Oracle Restaurants recommends that each task be stepped through in the script.

### Stepping Through the Script

Follow these steps to test the script:

1. Print the script for reference.
2. Mark through each step of the script as it is tested and correct it. This procedure helps track the steps tested.
3. Confirm that the script has the correct filename, links to the appropriate SIM interface, and that it is in the correct directory.
4. Execute each event in the script. Remember, an event can be initiated in three ways: by pressing a SIM Inquiry key, by pressing a SIM Tender key, or by responding to a message sent by an interfaced third-party system.
  - Make sure that the SIM Inquiry or SIM Tender key pressed executes the correct event. The key should be linked to a corresponding event in the script.
  - Test whether communications are active between the two systems and that each system responds appropriately to messages sent to it by the other.
5. Test each step of the event, such as the flow and logic of If...EndIf and For loop statements.
  - Check assumptions made in the script. If a condition must exist for the next step to occur, check the condition. The programmer might need to display an error message or perform another step until this condition is met.
6. Check the logic of each task. For example, if the script collects data from the user before querying a third-party database, make sure that the script prompts the user for data entry before starting the query.
7. Correct any detected syntax errors. The ISL error message will provide the number of the line in the script where the error is found.
8. Verify inputs and outputs. For example, if the script calls for a coupon to be generated when an operator closes a guest check, test for this case.

---

---

## 5 Using Variables

For users who are new to script writing, or need to familiarize themselves with script writing conventions, this chapter discusses basic script writing concepts to apply when creating scripts.

### Variables and ISL

As in other programming languages, the ISL supports the use of variables for holding information, such as integers or character strings that may change from one ISL event to another.

Typically, variable results are stored in expressions like the following example:

```
variable_name = expression
```

An *expression* is a combination of variables and operators. Expressions may also include constants and functions.

For example, in the expression below, the size of a window is computed from the number of elements in a list:

```
window_length = ListSize + 2
```

The user variable *window\_length* has a unique name defined by the user. This variable is compared, using the operator “equal to”, or =, to the expression on the right. The expression on the right contains a user variable called *ListSize*, which is added to the integer 2. The result of the expression on the right will be the value assigned to the user variable *window\_length*: *the ListSize plus 2*.

This chapter describes how to use the language elements that allow variable information to be held and evaluate expressions of variables.

This chapter contains the following:

- A list of the different kinds of data types variables that can be in ISL
- A discussion of the mathematical operators used to evaluate expressions containing variables
- A discussion of the type of user variables supported by the ISL

### Data Types

The ISL supports several kinds of data types, including **numeric**, **decimal**, **alphanumeric**, and **key** data types, to specify different kinds of variables and constants.

When a variable is declared using the `var`<sup>2</sup> command, its data type and size must also be declared. The type and size are referred to as the **variable\_specifier** and **type\_specifier**, respectively.

---

<sup>2</sup> For a complete description of the `var` command, refer to page 300.

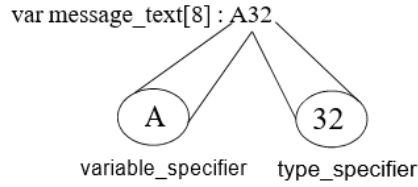

**Figure 3 Example var Command**

Note that the length specifier (“32” in the example above) is optional.

The table below lists the kinds of data types and provides the abbreviations that must be used when declaring them.

**Table 9 Data Types and Corresponding Abbreviations**

Data Type	Abbreviation	Description	Example
Numeric	Nx	The maximum size can be 32768 (N32768). However, only the first nine digits are significant when any arithmetic operation is performed.	If the variable were defined as test:N12 = 123456789012, then test+1 would not evaluate correctly due to truncation.
Decimal	\$x	These variables are used for decimal amounts. Operator entries will assume a decimal place according to the currency's default setting, as specified in the <i>Currency</i> file; for example, entering 1234 in the US results in an amount of 12.34. They may comprise <i>x</i> digits, (for example, \$4 in the US will support -99.99 to 99.99).  The maximum size can be 32768 (N32768). However, only the first sixteen digits are significant when any arithmetic operation is performed.	If the variable were defined as test:\$18 = 123456789012345678, then test+1 would not evaluate correctly due to truncation.

Data Type	Abbreviation	Description	Example
Alpha- numeric	A $x$	These variables may include any non-control character, including punctuation marks. They may comprise $x$ characters.	var name : a20
Key	key	This system variable is used for key press variables.	var keypressed : key

## Example

The example below declares a 32-character alphanumeric variable and a four-digit room number variable, respectively.

```
event : 1
var message_text[8] : A32 var room_num : N4
.
.
.
```

## Relational and Logical Operators

The mathematical operators described in this section are supported by the ISL. Before using these operators in a script, review each description carefully, as well as the [Operator Rules](#).

For an explanation of the operand types (N $x$ , \$ $x$ , A $x$ , and Key), see [Data Types](#).

### Unary Operators

There are two unary operators:

**Table 10 Unary Operators**

Operator	Description	Example
-	Negation operator (a minus sign). This is used to negate an expression.	-3 -count
NOT	Will negate the result of the expression. The NOT operator can be applied to expressions in the same way as the unary minus operator.	-3 -count

Given that ISL expressions are true if they evaluate to a non-zero value and false if they are zero, the NOT operator will change non-zero values to 0 and 0 values to non-zero. The expression NOT 3 is valid and will evaluate to a 0.

The NOT operator is generally used in **If**, **ElseIf**, and **While** statements to control program flow.

The following is an example of a loop that looks for the end of a file:

```
while NOT feof( fn )
.
.
.
Endwhile
```

## Binary Operators

The following table lists the available binary and logical operators in order of precedence (highest to lowest). AND and OR, the logical operators, have a lower precedence than all the binary operators:

**Table 11 Binary Operators**

Operation	Operator	Allowable Operand Types: Nx, \$x, Ax, and Key
multiplication	*	Nx, \$x
division	/	Nx, \$x
modulus	%	Nx, \$x
plus	+	Nx, \$x
minus	-	Nx, \$x
bit-wise and	&	Nx
bit-wise or		Nx
equality	=	Nx, \$x Ax, Key
greater than or	>=	Nx, \$x Ax, Key
greater than	>	Nx, \$x Ax, Key
less than or equal	<=	Nx, \$x Ax, Key
inequality	<>	Nx, \$x Ax, Key
less than	<	Nx, \$x, Ax, Key
logical and	AND	Nx
logical or	OR	Nx
String concatenation	&&	A

---

## Operator Rules

### Relational Operators

All relational operators produce a non-zero value if they are true, and 0 if they are false.

For example:

```
result = 1 < 2           //true, result will be non-zero
result = 100 < 4        //false, result will zero
```

### Logical (Boolean) Operators

The logical (Boolean) AND and OR operators treat their operand as either true (non-zero) or false (zero) values.

For example:

```
result = 5 AND 6
//true, since 5 and 6 are both non-zero result = 5 AND 0
//false, since 0 is false result = 0 OR 0
//false, since neither one is true result = 0 OR 5
//true, at least one value is non-zero
```

### Precedence

- ISL expression operands are evaluated from left to right until the end of the expression is reached. For example, in the following expression,  $1 + 5 + 2$ , the 1 is added to the 5, equaling 6, then 2 is added to 6, resulting in 8.
- When expressions mix operators (for example, + and \*), then ISL will use the precedence table to determine which subexpression within the expression will evaluate first. In the example, the \* operator has higher precedence than the + operator. Therefore, the last two operands will be combined first, even though they are not the first in the expression:  $1 + 5 * 2$
- The result is 11 ( $1 + 10$ ), rather than 12 ( $6 * 2$ ). The precedence rules are used for all operators. Since the < operator has greater precedence than the OR operator, then in the following expression:  $a < 1 \text{ OR } b > 3$

$a < 1$  and  $b > 3$  are evaluated first, and both results are combined with the OR operator.

### Overriding and Clarifying Precedence

The parentheses can be used to override the default precedence rules. Parentheses are used for two reasons:

- To override the default expression evaluation
- To clarify the expression

Subexpressions enclosed in parentheses **always** override the operator evaluation. For example, in the following expression:

```
(1 + 5) * 2
```

The  $1 + 5$  is evaluated first since it is within parentheses, even though the multiplier \* has higher precedence.

The following expression:

```
a < 1 OR b < 3
```

---

Can be rewritten as:

```
( a < 1 ) OR ( b < 3 )
```

It is good practice to always place parentheses around subexpressions, to reduce programming errors and to make scripts more easily understood and maintained.

For example, the following expression:

```
offset + width * 2 <= w_width / stlen + 1
```

Is equivalent to:

```
(offset + (width * 2) ) <= ( ( w_width / stlen) + 1)
```

The second expression is clearer in its intent.

## User Variables

User variables are defined by the interface designer and may be used to get operator input, such as customer name and address information, a room number, etc. They can also reference an entry in a message received over a SIM Interface.

### Declaring User Variables

Declare variables just as is in C, but in this case, use the `var` command to do this. These variables are given a value by an operator, or by the interface, in a response message. For example:

```
event inq : 5  
  
var rowcnt : n3  
.  
.  
.
```

### Guidelines

- The variable name must begin with a letter A-Z, a-z, or the underline character (`_`).
- The first character cannot be a number. It may subsequently include any character in the range A-Z, a-z, 0-9, or the underscore `_` character.
- Initially, numeric variables should always be set equal to 0.
- String variables should initially equal a null string " ".

Remember that when declaring SIM numeric or decimal variables, large variables used in mathematical operations may be truncated. All operations involving numeric variables use only the first nine digits, and decimal variables use only the first sixteen digits.

The scriptwriter can still declare and assign large variables. For example, it is still valid to create an N10 variable that will hold a telephone number, or an N16 variable that will hold an access code. However, any non-relational expressions may cause truncation and yield the wrong answer.

---

## Local and Global Variables

Variables can be declared either globally or locally.

### Global Variables

If a variable is declared outside of an Event procedure, it is considered global. The variable is called global because it can be referenced by any event or subroutine in the script. As a result, the ISL must maintain the contents of the variable the duration of a script. The variable is then reset at the start of a new transaction (for example, when tendering a check). Also, since the variable will be used by other events and subroutines in the script, a global variable needs to be declared only once at the top of the script before any events or subroutines.

### Local Variables

Conversely, a variable is considered local when it is declared inside an event procedure. Local variables are only maintained while the event procedure is being executed; executing the **EndEvent** command, or any other command that stops the script, purges the local variable from the event procedure. Thus, local variables must be declared within event procedures.

### Local Variables Used by Subroutines

Local variables declared by a parent event procedure are visible within a child subroutine. This functionality is possible because a local variable is accessible to the event in which it is included, and to any child subroutine called by the parent event. Moreover, the contents of a local variable, declared in the parent event, can be changed by the operation of a subroutine called by the same parent event. Consequently, the new contents of the local variable are retained when the subroutine is complete.

### CONST keyword

The 'const' keyword can be used in place of the 'var' keyword. The two places where const can be used are:

1. Global and local variable declarations
2. Parameter declarations

#### *Global and local variable declarations*

For global and local variable declarations, the constant must be defined at the time it is declared. For example:

```
const MAX_COUNT:N5 = 100
```

Given the declaration above the following statement will cause an error:

```
MAX_COUNT = i + 1
```

#### *Parameter declarations*

---

For parameter declarations a variable can be passed in, but the const variable inside the subroutine cannot be modified. See the comments in the code section below for behavior:

```
event inq:1
  var count:N5 = 20
  call Test( count )
  call Test( 30 )
endevent

sub Test( const c:N5 )
  // this will cause an error as it's declared as const
  c = 30

  // const will be turned into var but c will remain
  unchanged
  call Test2( c )
end

sub Test2( var d:N5)
  // this will not cause an error as a copy of c has been
  made
  // the local copy of 'd' will change.
  d = 40
endsub

sub Test3( ref e )
  // this will cause an error since e refers to the original
  const c.
  // Its "constness" carries through until a copy is made.
  e = 50
endsub
```

### Unspecified Variable Length

It is not necessary to specify the length of the variable in its declaration. For example, when declaring a string one would specify a length of 20 as:

```
var text:A20
```

Specifying the length of a variable is useful for formatting and input entry checking. Omitting the length specification makes it easier to write scripts. The variable's implicit length is "whatever it takes to hold its next assignment". For example:

```
var text:A
var number:N
var amount:$
```

### LVAR and LCONST keywords

There is an annoying SIM feature where a variable is 'visible' in all subroutines that it calls. For example:

---

```

event inq:1
    var count:N5 = 20
    call Test()
endevent

sub Test()
    // count is visible even though not declared in Test()
    count = 30
endsub

```

The 'lvar' and 'lconst' declarations were introduced to bring SIM variable handling to modern standards. The 'l' that prefixes the declaration means that the variable's scope is local to the event or subroutine.

```

event inq:1
    var a:N5 = 20
    lvar b:N5 = 20
    call Test()
endevent

sub Test()
    // a is visible even though not declared
    a = 30

    // b is not visible as it was declared locally
    b = 40
end

```

The reasons for using lvar and lconst are clear: they provide local scoping rather than global scoping. Global scoping is fraught with danger as it is too easy to overwrite parent variables by accidentally not declaring them first.

```

event inq:1
    var i:N5
    for i = 1 to 10
        call Test()
    endfor
endevent

sub Test()
    // the loop in inq:1 will only run once since we will
    // reset i to 10 upon exit.
    // if i was declared using 'lvar' then an error message
    // will appear here because
    // 'i' is not declared
    for i = 1 to 10
        call SomethingElse()
    endfor
endsub

```

Notes:

- 'lvar' and 'lconst' cannot be used at the global level.
- It is recommended that lvar and lconst be used whenever possible.

---

## SetLocalScoping

It can be troublesome to always remember to use `lvar` and `lconst` rather than `var` and `const`. A new command has been introduced that can force `var` and `const`, when declared in an event or sub, to *always* be local. If one uses the following command at the top of the script ...

```
SetLocalScoping 1
```

... then a `var` will 'become' an `lvar` and a `const` will become an `lconst`.

Notes:

- If you are writing a brand-new script, it is recommended that you always use local scoping. It is good programming practice. Without it your program can easily become unmaintainable.
- If you have a legacy script, be careful about setting this. A hidden bug may surface. On the other hand, you may *want* to set local scoping on so that you can find any latent bugs that have been hidden.

## Array Variables

Arrays of variables can also be declared by including an array size with the declaration. The syntax for an array variable is:

```
Var variable_name[array_size]:variable_specifier
```

The example below declares an array of strings named `message_text`, containing eight elements, each 32 characters in length.

```
var message_text[8]:A32
```

---

---

Note: The use of brackets in the example above does not denote an optional entry but is part of the syntax.

---

---

### Array assignment in declaration

SIM allows arrays to be initialized within the declaration of the variable. For example:

```
var somePrimes:N[5] = [2, 3, 5, 7, 11]
```

This syntax is necessary so that `const` arrays can be initialized. This syntax is only allowed when the variable is declared, not in normal assignment.

For more information on the `var` command, see page [8-112](#).

## Variable Size Variables

It is possible to declare a variable with a size that is defined by an expression, rather than a hard-coded number. If the SIM encounters an open parenthesis immediately following the type of the variable, it will assume that an expression follows, defining the variable's size. For example, the following commands have the same effect:

---

```
var window_width : N30
var window_width : N(15 + 15)
```

This feature is useful for declaring variables whose size is not known until run-time. For example:

```
var longest_str : A(max_str_len)
```

## Using List Arrays and Records

The application data message contains the information that the SIM sends to and receives from an interface. The message consists of a set of ASCII fields, separated by the ASCII field separator (1CH).

In many cases, the number of variables to be sent by the SIM or the interface is not known until run-time. For example, a script may query the PMS for a list of guests whose last name starts with "SMITH." The PMS may respond with two names, or with ten names, depending on who is in the hotel at the time.

To send and receive variable amounts of data, ISL uses two methods: list arrays and records.

### List Arrays

The SIM provides more than one method for sending and receiving variable amounts of data within one message. The simplest method is to send a list. A list consists of a *list\_size* and the *array\_variable* that contains the list. The *list\_size* is any user-defined integer variable. The *array\_variable* is any user-defined array, as shown on page 5-10.

### Specifying a List Array

A list is specified for an **RxMsg** or **TxMsg** command by using empty array brackets ( [ ] ) after the array name.

For example: **Rxmsg** *list\_size*, *list[]*

When specifying a list array, follow these guidelines:

- The variables used for the list size and the list are user-defined.
- The list size variable should always precede the list array variable.
- Array system variables (for example, @DTL\_OBJNUM) cannot be used as list arrays.
- The values in the list[ ] should be formatted into as many lines as are specified in list\_size. In the example below, list\_size is 5, thus five values from the list[ ] will be formatted if these ISL statements are executed.

```
var list_size : N5
var list[ 10 ] : A20
txmsg list_size, list[]
```

Using the same example, if the [fs] symbol stands for the field separator, then the following lines will create these messages:

```
list[ 1 ] = "L1"
list[ 2 ] = "L2"
list[ 3 ] = "L3"
list[ 4 ] = "L4"
```

```

list[ 5 ] = "L5"

txmsg 3, list[] //3[fs]L1[fs]L2[fs]L3
txmsg 5, list[] //5[fs]L1[fs]L2[fs]L3[fs]L4[fs]L5
txmsg 0, list[] //0

```

- The PMS should read the first value in the message and receive that many elements from the rest of the message. The **RxMsg** command reads the data from the message in a similar manner. For example:

```

var listsize : N5 var list[ 10 ] : A20

//If message from PMS is: 2[fs]L1[fs]L2, then
//listsize = 2
//list[1] = "L1"
//list[2] = "L2"

rxmsg listsize, list[]

//If message from PMS is: 4[fs]L1[fs]L2[fs]L3[fs]L4, then
//listsize = 4
//list[1] = "L1"
//list[2] = "L2"
//list[3] = "L3"
//list[4] = "L4"

rxmsg listsize, list[]

```

In another example, the script collects a guest name from the operator, transmits the guest's name to the PMS, receives a list of names from the PMS, and displays the list in a window:

```

event inq : 1
    var name : A20
    input name, "Enter guest name"
    txmsg "GST_INQ", guest
    waitforrxmsg
endevent

event rxmsg : GST_RSP
    var guest_count : N5 //declare list size
    var guest_name[10] : A20 //declare list
    rxmsg guest_count, guest_name[]
                                //receive up to 10 names
                                //open up window

    window guest_count, 25, "Guest List"
    listdisplay 1, 1, guest_name //display names
    waitforclear
endevent

```

- Lists can be intermingled with other non-list variables, as well as other lists. In the following example, one single variable and two lists, each with its size variable, are received from the PMS:

```

rxmsg status, guest_count, guest_name[], action_count,\ action_list[]

```

- For each list, only one array may be assigned. It is possible, for example, for the PMS to send not only the guest's name, but also the room number. One way to handle this is to receive two lists within one message:

```
event rxmsg : GST_RSP
  var guest_count : N5
  var guest_name[10] : A20h
  var guest_room[10] : N5
  rxmsg guest_count, guest_name[], guest_count,\
  guest_room[]
  .
endevent
```

### Implicit List Sizes

There are occasions where the script writer may want to use lists but does not want to specify the `list_size`, since the `list_size` is not specified in the data. For example, assume that each line in a file contains 20 fields. For the ISL to read each line, a separate variable must be specified in the `Fread` command for each field.

```
var n[20]
fread fn, n[1], n[2], n[4], n[5], n[6], n[7], n[8],\
  n[9], n[10], n[11], n[12], n[13], n[14], n[15], n[16],\
  n[17], n[18], n[19], n[20]
```

The ISL provides a method for specifying *list\_sizes* implicitly for those cases when the data does not contain a *list\_size*. An implicit *list\_size* is identified by a pound symbol (#) placed before the *list\_size*. Alternatively, the example above could be written as:

```
var n[20]
fread fn, #20, n[]
```

Only integer expressions may be placed in the implicit `list_size` field. Integer variables may also be used.

```
var n[20]
var size : N5 = 20
fread fn, #size, n[]
```

Implicit *list\_sizes* may be used anywhere standard *list\_sizes* may be used.

### Records

ISL also provides a more powerful, yet more complicated, syntax for specifying variable amounts of data called **records**. In this format, the variables following the list size are in groups of records.

The syntax for receiving this type of information is:

```
listsize, list1[] : list2[] : list3[] ...
```

The colon separates fields within a record and must be used when specifying records.

For example, if the PMS received an inquiry on SMITH, then it may want to group the data as follows:

```
3[fs]Smith[fs]1423[fs]Smithers[fs]1827[fs]Smithson[fs]1887
```

Note that each record consists of a name followed by a room number. To receive the message above, use the following statement:

```
rxmsg count, name[] : room[]
```

In this case, the variables are set as follows:

```

count = 3
name[1] = "Smith"
name[2] = "Smithers"
name[3] = "Smithson"
room[1] = 1423
room[2] = 1827
room[3] = 1887

```

The same format can be used for transmitting data.

A list specification is a special case of a record format, where each record consists of one element.

## Promotion

ISL allows the programmer to freely combine and assign variables of the different types. For example, it is possible to add a string and an integer and assign it to a decimal value.

```
var amt : $10 = 12 + "25" + 100.45
```

Whenever two variables and/or constants are operated upon with an operator, and they are not the same types, one will be “promoted” (have its type changed) before the operation takes place.

Strings promote to integers and integers promote to decimal values. A final promotion occurs when the expression is assigned to a variable. Therefore, the expression is promoted (or demoted) to the variable type.

For example, if the following variables are declared:

```

var string : A20
var integer : N10
var decimal : $10

```

Then the following statements are assigned within an Event procedure, the statements would be equivalent to:

**Table 12 Example Variable Assignment**

Assignment	Equivalent To
string = "12" + 35	string = "47"
string = "14.15" + 2	string = "16"
string = "14.15" + 2.00	string = "16.15"
integer = "14" + 12.5	integer = 26
integer = "14.5" + 12.5	integer = 27 expression was real, and then demoted to integer
decimal = 12.23 + 1	decimal = 13.23
decimal = "12.23" + 1	decimal = 13.00 "12.23" + 1 yields an integer 13, which is then assigned to decimal

Strings are converted to integers by using the first digits in the string field. “12.35” converts to an integer 12, since “.” does not belong in an integer. “12NUM” also converts to 12. Therefore, it is legal to write:

---

```
integer = "ABC123" // integer = 0
```

Only relational operators are allowed between strings; see Relational and Logical Operators on page 2.

Correct:

```
integer = "12" > "35"
```

Incorrect:

```
integer = "12" + "35"
```

## DefKey

Key definitions have these fields:

- Command: The command to execute; a word instead of a number
- Number: The object number associated with the command. If this is a menu item command, then Number is the object number.
- Index: Like number, this depends on the command.
- Text: Preset keyboard buffer OR characters for the ASCII command.
- Arguments: Command-dependent.

A new function 'defkey' has been created that allows a SIM script to set one or more fields of the command (formerly known as 'key') for OPS to process-in a LoadKybdMacro command. The syntax is:

```
DefKey(OpsCommandType, Name: Val ue, Name: Val ue, . . . )
```

Where:

- OpsCommandType: A string which defines the command to process.
- Name: A one character identifier for the field type. For example, 'N' corresponds to number.
- Value: The value for the name. For example, 'N:2' indicates that the number field should be set to 2. The value can be hardcoded, or it can be an expression.

Valid Name values

- N - Number
- A - Arguments
- I - Index
- T - Text

Example:

```
var myKey : key
myKey = defkey("Payment", N:2, A:"Cash:Cash")
loadkybdmacro myKey
```

Depending on the OpsCommandType used, arguments are sometimes required.

---

Sample without arguments:

```
defkey( "MinimizeApplication" )
```

Sample with a Number Value:

```
defkey( "MenuItem", N:104 )
```

Sample with a Number Value and an Arguments Value:

```
defkey( "Payment", N:2, A:"Cash:Cash" )
```

Sample with an Arguments Value using the @ApplicationName System Variable:

```
var sKey : A64  
format sKey as @ApplicationName, ":20"  
defkey( "siminquire", A:sKey )
```

---

---

## 6 ISL Printing

This chapter contains an introduction to the ISL command and system variables that facilitate output to print devices.

### Getting Started with ISL Printing

Printing in ISL is accomplished using the **StartPrint**, **PrintLine**, and **EndPrint** directives (or their variants).

- Backup printers may be specified
- Printouts can end with or without Form Feeds
- Printing text in double-wide characters and red ink is supported

This chapter focuses on how to start and direct print jobs to printers. In performing these tasks, the other options available are covered as well, including detecting the status of print jobs, redirecting print jobs to ISL-defined backup printers, and defining a reference line for print error messages.

### ISL Print Commands and System Variables

All commands and system variables associated with ISL printing are discussed. For complete descriptions, including syntax and examples of all commands discussed in this section, refer to [ISL Commands](#). For more information about system variables and their use, refer to [ISL System Variables](#).

### Starting an ISL Print Job

Print jobs include guest checks, customer receipts, validation chits, local backup printing, remote order printing, as well as journal printing.

These types of print jobs are initiated by variations of the **StartPrint** command described in this section. These variations are designed to accommodate the ability to detect whether a print job completed successfully by using the `@PRINTSTATUS` system variable.

### ISL StartPrint Commands

Printing in ISL is started using the command in the table below. The **StartPrint** command is used to print to a standard remote printer. These printers print a maximum of 32 characters per line and understand special formatting.

**Table 13 ISL StartPrint Commands**

Command	Sets @PRINTSTATUS	Form Feed	Backup Printer	Reference Line
StartPrint...EndPrint[FF/NOFF]	◆ <sup>3</sup>	◆	◆	◆

### Extended Printing and Printing Binary Data

Extended and Binary printing is possible using a certain set of ISL command and system variables. See the following:

- Print\_Header Event
- Print\_Trailer Event
- @HEADER System Variable
- @TRAILER System Variable
- PrintLine Command

### Form Feeds

The EndPrint command can issue three types of form feeds:

- EndPrint
- EndPrintNOFF
- EndPrintFF

The EndPrint command is used when the default behavior for formfeeding at the end of a print session should be used. For journal printers, there is no formfeed. For all other printers a form feed is used.

The EndPrintNOFF command is used to prevent a formfeed being sent at the end of a print job.

The EndPrintFF command is used to always force a formfeed at the end of a print job.

### Backup Printing and Reference Lines

The commands used for print jobs also allow for the specification of a backup printer in case the print job fails. This backup printer overrides any backup printer already programmed in the database for the specified printer. In addition, the text can be specified, called a reference line, to appear in printer error messages returned when print jobs fail.

### Specifying an ISL Printer

When specifying a **StartPrint** command, there are two options for defining a printer: the object number or a system variable.

---

<sup>3</sup> Always set to Y.

---

## Using Printer Object Numbers

All printing requires that a printer be specified by the **StartPrint** command. A printer can be identified either by its object number, or by a system variable. For example, if the print job goes to device 8 in the Printers module, using the object number, the **StartPrint** command would be written as follows:

```
StartPrint 8
```

Although using this method is valid, it has a primary disadvantage. The destination printer for ISL print jobs may differ for each workstation. If the object number had to be hardcoded, as it is in the example above, then a different script would be required for each workstation. Thus, each script would need to specify the printer to which each workstation must print, limiting the flexibility of the script.

## Considerations

- Although it is legal to specify a printer object number of 0, all print jobs printing to 0 will not print—anywhere.
- An invalid object number value (-1) will generate an ISL error.

## Using System Variables

A more efficient method of specifying printers is using system variables. These system variables return the value of the object number of the printer. For example, the @CHK system variable will return the object number of the printer defined as the Check Printer for that workstation in the database.

Since each workstation will have a different entry for its Check Printer, the ISL command “startprint @chk” will specify a different printer for each UWS. For example, on Workstation #1, @CHK is 8 but, on Workstation #2, @CHK is 12. Using a system variable instead of the object number to specify a printer means that each workstation can use the same script, yet still print to different printers.

## ISL Printer System Variables

The printer system variables available in ISL include the following:

**Table 14 Printer System Variables**

System Variable	Description
@CHK	Guest Check Printer
@RCPT	Customer Receipt Printer
@ORDR[1...15]	Remote Order or Local Backup Printer
@VALD	Validation Printer

A table describing all options available with each valid ISL printer is provided with the detail description of the **StartPrint** command. See [StartPrint...EndPrint\[FF/NOFF\]](#).

---

## Using Print Directives

The ISL Print Directives consist of one-byte values sent to the printer, defined by the **StartPrint** command, to change the print type of the *expression* which follows it. These directives are similar in function to standard parallel printer escape sequences: Each print directive is a non-printable character and is included in the print data sent to the printer.

### The Printline Command

Print Directives are system variables and are arguments of the **Printline** command. This command allows the ISL to print information provided as a text string or variable.

The **Printline** command prints a line on the selected printer defined by the **StartPrint** command, which must be issued before **Printline**. Depending on the print directives specified in the **Printline** statement, the expression will print in double-wide characters or red ink.

### Print Type System Variables

Several system variables that evaluate to these print directives are provided by the ISL to facilitate printing expressions in double-wide characters and in red ink.

These directives are described in the table that follows.

**Table 15 Print Type System Variables**

Print Directive	Description
@DWON	Prints the following text or variable fields double-wide. Single- and double-wide characters may be mixed on the
@DWOFF	Prints the following text or variable fields double-wide. Single- and double-wide characters may be mixed on the
@REDON	Prints an entire line in red. It is not possible to mix red and black characters on the same line. All new lines default to
@REDOFF	Returns printing to default ink (blue, black, etc.) All new lines default to black.

### Considerations

- Print directives (@DWON and @DWOFF) may be inserted between expressions, but only affect the expression to the right.
- The print directives are reinitialized at the end of each printed line.
- If no print directives are specified, printing will be in black and single- wide.

### Example

The following example illustrates how the same expression can be printed in four different ways by using a combination of these print directives:

```
Printline "Print line" //prints in black
Printline @redon, "Print line" //prints in red
```

---

```

Printline @dwn, "Print line"           //prints in black,
                                         // double-wide
Printline @dwn, @redon, "Print line"   //prints double-wide
                                         // in red ink

```

## Print Directives and Subroutines

Since the print directives are normal ISL strings, they can be passed as arguments to subroutines. The following example prints an array of data and displays a header using a print directive passed in as a parameter to the subroutine:

```

sub print_list( var printer : N9, var listsize : N5,\ ref
  list[], ref header_string, var directive : A1 )

  if printer = 0
    errormessage "Printer dten is 0. Cannot print." exitcancel
  endif

  startprint printer
    printline "-----"
    printline directive, header_string
    printline "-----"
    listprint listsize, list endprint

endsub

```

The subroutine could be invoked in the following fashion:

```

event inq : 1
.
.
.
print_list( @chk, sz, data[], "NORMAL HEADER", @redoff )
.
.
.
print_list( @rcpt, sz, data[], "RED HEADER", @redon ) endevent

```

## Backup Printing

Whenever the **StartPrint** command is issued, a print job will occur. If the print job is unable to complete successfully, it will go to the backup printer defined in the Symphony database for each printer type (for example, @chk, @rcpt, ...).

However, there are instances when a backup printer different from the one defined in Symphony should be specified. To accommodate these instances, the **StartPrint** command accepts an optional second argument. This optional argument specifies the object number of the backup printer, overriding the backup printer programmed in the Symphony database.

For example, if the Check Printer is normally backed up by the Customer Receipt Printer but the script requires that a print job to the Check Printer back up to the Order Printer, the following command should be issued:

```

STARTPRINT @chk, @ordr[1] // back up to @ordr[1] instead of @rcpt

```

---

## Considerations

The SIM will only route the print job to the backup printer defined in the command syntax if the primary printer specified is a system variable. Otherwise, the ISL does not know to which printer type the job should be re-routed. For example, assume that the @CHK system variable equals 2.

```
STARTPRINT @chk           // ISL can determine backup printer
STARTPRINT 2              // ISL cannot determine backup printer
```

In the first line, the SIM will correctly determine the backup for the Check Printer, since “@chk” is explicitly specified. In the second line, the number 2 is used instead, and ISL cannot correctly determine the backup printer, and so, no backup is used.

## Reference Strings

Whenever the SIM is performing a print job and an error occurs during printing (paper out, door open), an error message will appear on the display of the workstation explaining the error. Included in this error message is a line of text identifying the print job.

Normally, ISL will leave this line blank. However, this reference line can be specified in the **StartPrint** commands.

```
STARTPRINT @chk           // use default backup
STARTPRINT @chk, @rcpt    // no reference line
```

```
STARTPRINT @chk, @rcpt, "Printing Customer Coupon" //ref line
```

---

---

# 7 ISL System Variables

This chapter summarizes all ISL system variables in an A-Z reference format.

## System Variables

System variables return status information from Symphony, Microsoft Windows Status flags, or the PMS System, as well as provide access to transaction totals and other transaction parameters.

The following can be accomplished using the system variables that the ISL supports:

- Access the system transaction variables and totals information
- Set certain operational parameters.

This chapter contains a detailed description of each system variable.

## System Variable Summary

For quick reference, a summary of system variables in alphabetical order and in order by category of function begins on page 7-1.

## Specifying System Variables

Review this section to determine the guidelines to follow when specifying system variables.

## Specifying System Variables

This section contains guidelines to follow when specifying system variables in ISL statements.

### Guidelines for Specifying System Variables

Follow the guidelines below when specifying system variables:

- The names for system variables are reserved; do not declare other user variables using the same name.

The example below is incorrect because the local variable *ccnumber* has the same name as the system variable @CCNUMBER, which returns a credit card account number.

```
event : 1
  var ccnumber : A16
.
.
.
```

This problem can be corrected by replacing *ccnumber* with *account\_num*, which is a user variable that represents the credit card account number, but is not a system variable.

```
event : 1
  var account_num : A16
.
.
.
```

- Always precede each system variable with an At @ character (for example: @SI[1]).
- Never put spaces between the At @ and the system variable name.

Correct: @SI[ 1 ]

Incorrect: @ SI[ 1 ]

- Before using a system variable, review the description carefully for any special considerations, such as:
- Most system variables must be used in conjunction with other commands, functions, or other system variables. For example, the @DWON system variable can only be used with the **Printline** command.
- Some system variables are only valid within a certain event. For example, @CCNUMBER will only return valid values if issued from within a tender/media event referencing a credit card tender type.
- A strategically placed system variable may or may not be required within the script. For example, the @WARNINGS\_ARE\_FATAL system variable must be placed at the top of the script. But the @LINES\_EXECUTED system variable can be placed anywhere in a script.
- Just as there are user variables that can be specified as arrays, there are array system variables. Array system variables require a reference to an array index. “Using an Index to Specify System Variables” below describes how to issue these types of system variables.

## Using an Index to Specify System Variables

Specifying array system variables is the same as specifying user-declared array variables. Array references in ISL take the form:

```
<array name> [ <expression> ]
```

Where *<array name>* can be either a user or system array variable, and

*<expression>* (for example, the index) can be a user variable, another system variable, a constant, a string, a function, or an equation.

If the array index evaluates to an expression within the array limits for the system variable, the index can be specified as a user variable, another system variable, a constant, a string, a function, or an equation. In the following examples, three different references evaluate to 3:

```
@si[ 3 ]                // constant
@si[ 6 - 3 ]           // equation
@si[ ( index * 2 ) - 1 ] // equation using user
variable,
                        //where index = 2
```

## Array Subscripts

The difference between system array variables and user-declared array variables, is that system array variables already have been declared and filled with the corresponding information. Consequently, there is no need to declare the subscripts of the array.

For example, the user-declared array variable must be declared as follows:

```
var myarray[5] : A20
```

---

```
myarray[1] = "mytest"  
myarray[2] = "mytest"  
myarray[3] = "mytest"  
myarray[4] = "mystes"  
myarray[5] = "mytest"
```

But a system array variable can be specified as:

```
@si[3]
```

For a system array variable, the variable data type and size, and subscript are assumed by the ISL to reference Sale Itemizer #3. If executed by a script, this system array variable would return the totals posted to this sales itemizer on the current guest check.

### Array Index Limits

The array index limits are included for system variables with the detail description of each system array variable. These limits vary depending on the system variable.

If the array index exceeds the limit when referencing the system variable, an error will occur. For example, below are invalid limits for the @SI system array variable:

```
@si[10] //incorrect  
@si[-10] //incorrect
```

The array index for @SI must evaluate to an index between 1 and 16.

All array indices start at 1, and not 0. For example, @si[0] will generate an error.

### Embedded Index vs Array-Index

System variables that require an index (for example, DTL\_\*, @SI, etc.) can be referenced in two ways: by an embedded index or array-index. Both methods enable older versions of SIM scripts to maintain compatibility with the ISL. In early versions of the ISL, there was support only for the embedded index method.

If using the embedded index to maintain older SIM scripts (Version 1.01S or earlier), the desired index is placed immediately after the system variable.

For example:

```
@SI2, @TAX1, @TXBL1, @DTL_STATUS9
```

In scripts compatible with Version 1.01T or higher of the ISL, the array-index method is the preferred way to specify system array variables. The array-index requires to reference the index as an array.

For example:

```
@SI[ 2 ], @TAX[ 1 ], @TXBL[ 1 ], @DTL_STATUS[ 9 ]
```

---

**Note:** The embedded-index method remains in ISL to retain compatibility with older scripts and should not be used with new scripts.

---

---

## System Variable Summary

For quick reference, this section contains an alphabetical summary of all ISL system variables.

---

**Note:** ISL variables are listed by category in Appendix C.

---

**Table 16 System Variable Summary**

Variable Name	Field/Parameter
@ACTIVE_LANGID	ID Number of Currently Selected Language
@ADDXFER_CHK_FROM	Check Number of the Check Being Transferred From
@ADDXFER_CHK_TO	Check Number of the Check Being Transferred To
@ADDXFER_GRP_FROM	Table Group Number of the Check Being Transferred From
@ADDXFER_GRP_TO	Table Group Number of the Check Being Transferred To
@ADDXFER_RVC_FROM	Rev. Center Number of the Check Being Transferred From
@ADDXFER_RVC_TO	Rev. Center Number of the Check Being Transferred To
@ADDXFER_TBL_FROM	Table Number of the Check Being Transferred From
@ADDXFER_TBL_TO	Table Number of the Check Being Transferred To
@APPLICATIONNAME	
@AUTHEMP	
@AUTHEMP_FNAME	
@AUTHEMP_LNAME	
@AUTHTYPE	
@AUTOSVC	Auto Service Charge
@AVAILABLEMEMORY	
@BOOTSERIALNUM	
@BOOTSERIALSTR	
@CASH_DRAWER	
@CENTER	Center Column in ISL-defined Window
@CHANGE	Change Due

<b>Variable Name</b>	<b>Field/Parameter</b>
@CHECKDATA	Facsimile of Check
@CHGTIP	Charged Tip
@CHK	Guest Check Printer
@CHKINFOKEY	
@CHK_OPEN_TIME	Date and Time Check Opened
@CHK_OPEN_TIME_T	Current Check Open Time
@CHK_PAYMNT_TTL	Current Check Payment Total
@CHK_TTL	Current Check Total
@CKCSHR	Guest Check Cashier Number
@CKCSHR_NAME	Guest Check Cashier's Name
@CKEMP	Check Employee
@CKEMP_CHKNAME	Check Employee's Check Name
@CKEMP_FNAME	Check Employee's First Name
@CKEMP_LNAME	Check Employee's Last Name
@CKEMP_TYPEDEF	
@CKID	Guest Check ID
@CKNUM	Check Number
@CLIENT_ONLINE	Determine if SAR Workstation is Online
@DATASTORE	
@DAY	Current Day of Month
@DAYOFWEEK	Current Day of Week
@DBVERSION	Current Database Version
@DEBUGTRACE	
@DETAILSORTED	Detail Sorting Status
@DSC	Discount Total
@DSC_OVERRIDE	When a manual discount is entered, a SIM 'Discount' script can decrease the amount of the discount by setting this variable to the desired discount amount
@DSCI	Discount Itemizer Value
@DTLCHILDSELECTED	
@DTL_DEFSEQ	Definition Sequence of Detail Item
@DTL_DETAILLINK[ <i>expression</i> ]	

<b>Variable Name</b>	<b>Field/Parameter</b>
@DTL_DSC_EMPL[ ]	Employee who is getting the employee meal discount for the specified detail entry
@DTL_DSCI[ ]	Menu Item Detail Class Discount Itemizer Value
@DTL_FAMGRP[ ]	Menu Item Family Group
@DTL_INDEX	Index of the detail which fired the SIM event
@DTL_IS_COMBO[ <i>expression</i> ]	
@DTL_IS_COMBO_MAIN[ <i>expression</i> ]	
@DTL_IS_COMBO_PARENT[ <i>expression</i> ]	
@DTL_IS_COMBO_SIDE[ <i>expression</i> ]	
@DTL_IS_COND[i]	Determines if a Guest Check Menu Item is a Condiment
@DTL_IS_ON_HOLD[ <i>expression</i> ]	
@DTL_IS_VOID[i]	When set (non-zero), the specified detail is a Voided Item
@DTL_MAJGRP[ ]	Menu Item Major Group
@DTL_MLVL[ ]	Main Menu Level of Detail Item
@DTL_NAME[ ]	Name of Detail Item
@DTL_OBJNUM[ ]	Object Number of Detail Item
@DTL_PLVL[ ]	Price Level of Detail Item
@DTL_PMSLINK[ ]	PMS Link of Detail Item
@DTL_PRICESEQ[ ]	Price Sequence Number of Detail Item
@DTL_QTY[ ]	Quantity of Detail Item
@DTL_SEAT[ ]	Seat Number of Detail Item
@DTLSELECTED	
@DTL_SLSI[ ]	Menu Item Detail Class Sales Itemizer Value
@DTL_SLVL[ ]	Sub-menu Level of Detail Item
@DTL_STATUS[ ]	Status of Detail Item
@DTL_SVC_LINK[ ]	Stored Value Card Link

Variable Name	Field/Parameter
@DTL_SVC_TYPE[ ]	Stored Value Card Type
@DTL_SVCI[ ]	Menu Item Detail Class Service Charge Itemizer
@Dtl_TaxTtl[ <i>expression</i> ]	Tax Total of Detail Item
@DTL_TAXTYPE[ ]	Active Tax Types
@DTL_TIMED_FIRE_TIME[ <i>expression</i> ]	
@DTL_TTL[ ]	Total of Detail Item
@DTL_TYPE[ ]	Type of Detail Item
@DTL_TYPEDEF[ ]	Returns the Detail Item Type Definition
@DWOFF	Double-wide Characters OFF
@DWON	Double-wide Characters ON
@EMPLDISCOUNT	In a discount event, this variable is the number of the employee discount
@EMPLDISCOUNTEMPL	In a discount event, this variable is the employee number of the discount receiving the employee discount
@EMPLOPT[ ]	SIM Employee Options #1-#8
@EPOCH	EPOCH Time
@ERRORMESSAGE	
@EVENTARGUMENTS	
@EVENTID	String that represents the event ID
@EVENTNAME	
@EVENTTYPE	String that represents the event type
@FIELDSTATUS	Data Entry Field Status Flag
@FILE	
@FILE_BFRSIZE	User Definable Variable
@FILE_ERRNO	Standard Error Number Value
@FILE_ERRSTR	Standard Error String based on @FILE_ERRNO
@FILELINEMARKER	
@FILE_SEPARATOR	Field Separator for File I/O Operations
@FILTER_ACTIVE	Seat Filter Active
@FILTER_MASK	Current Seat Filter Mask

<b>Variable Name</b>	<b>Field/Parameter</b>
@GRPNUM	Table Group Number
@GST	Guest Count
@GSTRMNG	Guests Remaining after Proration
@GSTHISTENDER	Guest Count Associated with Split Tender
@GUID	The GUID of the Current Check
@HEADER	Print Header from Print_Header Event
@HOUR	Current Hour of Day
@IGNOREPRMT	Bypass general operator prompts with the Enter key
@INEDITCLOSEDCHECK	Edit Closed Check Entry
@INPUTSTATUS	User Input Status Flag
@INREOPENCLOSEDCHECK	Reopen Closed Check Entry
@INSTANDALONEMODE	Determine if SAR Workstation is Offline
@ISJOURNALPRINT	
@ISUNICODE	Determines if Unicode Characters are Supported
@JNL	
@KEY_CANCEL	Cancel Key
@KEY_CLEAR	Clear Key
@KEY_DOWN_ARROW	Arrow Down Key
@KEY_END	End Key
@KEY_ENTER	Enter Key
@KEY_EXIT	Exit Key
@KEY_HOME	Home Key
@KEY_LEFT_ARROW	Arrow Left Key
@KEY_PAGE_DOWN	Page Down key
@KEY_PAGE_UP	Page Up key
@KEY_RIGHT_ARROW	Arrow Right key
@KEY_UP_ARROW	Arrow Up key
@LANG_ID[]	ID Numbers of Defined Languages
@LANG_NAME[]	Language Names for Defined Languages
@LASTCKNUM	Last Check Number Assigned to Guest Check

<b>Variable Name</b>	<b>Field/Parameter</b>
@LINE	Current Line Executed in Script
@LINE_EXECUTED	Lines Executed in Script
@MAGSTATUS	Magnetic Card Entry Status Flag
@MAXDTLR	Maximum Size of @TRDTLR
@MAXDTLT	Maximum Size of @TRDTLT
@MAXKYBDMACRO	
@MAX_LINES_TO_RUN	Maximum Lines of Script to Execute
@MINUTE	Current Minute
@MONTH	Current Month
@NEXTMYOPENCHECKGUID	
@NUL	A binary 0 should be sent when printing binary data
@NULL	
@NUMDSC	Active Discounts
@NUMDTLR	Number of Detail Entries this Service Round
@NUMDTLT	Number of Detail Entries for Entire Transaction
@NUMLANGS	Number of Languages
@NUMOPENCHK	
@NUMSI	Active Sales Itemizers
@NUMSVC	Active Service Charges
@NUMTAX	Active Tax Rates
@OBJ	Object number of the detail item for the event
@OFFLINELINK	Used to link to an offline PMS system
@OPNCHK_CKNUM[expression]	
@OPNCHK_TREMPID[expression]	
@OPNCHK_TREMPNUM[expression]	
@OPNCHK_WSID[expression]	

<b>Variable Name</b>	<b>Field/Parameter</b>
@OPNCHK_WSNUM[expression ]	
@OPSCONTEXT	
@ORDERTYPE	Order Type
@OrderType_Name	
@ORDR[ ]	Remote Order or Local Order Printer
@OS_PLATFORM	1 - Windows® CE 3 - Win 32
@PICKUPLOAN	Value of the pickup or loan amount
@PLATFORM	Hardware Platform
@PMSBUFFER	PMS Message
@PMSLINK	Revenue Center PMS Link
@PMSNUMBER	Object Number of PMS
@PREVPAY	Previous Payment
@PRINTSTATUS	Print Status Flag
@PROPERTY	The Property Number of the Workstation
@QTY	Quantity of the detail item for the event
@RANDOM	Returns a random value between 0 and $2^{32} - 1$
@RCPT	Customer Receipt Printer
@REDOFF	Red Ink OFF
@REDON	Red Ink ON
@RETURNSTATUS	Transaction Item Return Indicator
@RUNNINGDIRECTORY	
@RVC	Revenue Center Number
@RVC_NAME	Current Revenue Center Name
@RXMSG	Name of Return Message
@SEAT	Active Seat Number
@SECOND	Current Second
@SI[ ]	Sales Itemizers
@SI_DSC[expression]	
@SIMDBLINK	Links to the SIMDB DLL to the database
@SRVPRD	Serving Period

Variable Name	Field/Parameter
@STACKFRAMETEXT	
@STRINGARGS	
@SVC	Service Charges
@SVC1	Service Charge Itemizer Value
@SYSLOGTRACE	
@SYSTEM_STATUS	Shell Return Status
@TAX[ ]	Tax Collected
@TAXRATE[ ]	Tax Rate
@TAXVAT[ ]	Returns the Value Added Tax Amount for Tax Rate "X"
@TBLID	Table ID
@TBLNUM	Table Sequence Number
@TICKCOUNT	
@TMDNUM	Tender/Media Number
@TNDTTL	Tender Total
@TOTALMEMORY	
@TRACE	Output Line of Script to 8700d.log
@TRAILER	Print Trailer from Print_Trailer Event
@TRAININGMODE	Training Mode Status Flag
@TRCSHR	Transaction Cashier Number
@TRDTLR	Transaction Detail of Current Service Round
@TRDTLT	Transaction Detail of Entire Check
@TREMP	Transaction Employee
@TREMP_CHKNAME	Transaction Employee's Check Name
@TREMP_FNAME	Transaction Employee's First Name
@TREMP_LNAME	Transaction Employee's Last Name
@TREMP_TPEDEF	
@TTL	Amount of the detail item for the event
@TTLDUE	Total Due
@TXBL[ ]	Taxable Sales Itemizers
@TXEX_ACTIVE[ ]	Checks if the Tax is Exempt at the Specified Level

Variable Name	Field/Parameter
@UNMANAGEDDLLLIST	
@USEDMEMORY	
@USERENTRY	Data Entered Before SIM Inquiry Key Activated
@VALD	Validation Chit Printer
@VARIABLEFRAMETEXT	
@VERSION	SIM Version Number
@VOIDSTATUS	Transaction Item Void Indicator
@WARNINGS_ARE_FATAL	Strong Checking
@WCOLS	Number of Columns in ISL-defined window
@WEEKDAY	Day of Week
@WROWS	Number of Rows in ISL-defined window
@WSID	User Workstation ID number
@WSNUM	User Workstation Object Number
@WSSUBTYPE	User Workstation Sub Type
@WSTYPE	User Workstation Type
@YEAR	Current Year
@YEARDAY	Current Day of Year

## ISL System Variable Reference

This section is an A-Z reference of the system variables supported by the ISL. Each system variable includes the following information:

- **Description:** Summarizes the function of the system variable.
- **Type/Size:** Contains the symbol that represents the data type and size of the field or total returned.
- **Syntax:** Provides the proper way to specify the system variable and any arguments, as well as a description of each argument.
- **Remarks:** Gives more detailed information of the system variable, its arguments, and how the system variable is used.
- **Example:** Includes an example of the system variable being used in a script. *This section may not appear in the detail description of each system variable.*
- **See Also:** Names related system variables, commands, functions, and other documentation to consult.

---

## ACTIVE\_LANGID

### Description

This system variable holds the ID number of the currently selected language.

### Type/Size

N9

### Syntax

@ACTIVE\_LANGID

### Remarks

- This system variable is Read-Only.
- This system variable is only available on SAR Ops.

## ADDXFER\_CHK\_FROM

### Description

This system variable returns the check number of the check being transferred from when called inside an XFER\_CHECK event.

Inside the ADD\_CHECK event, this system variable will return the check number of the check being added to the current check.

### Type/Size

N9

### Syntax

@ADDXFER\_CHK\_FROM

### Remarks

- This system variable is Read-Only.
- This system variable is only valid in ADD\_CHECK or XFER\_CHECK SIM events.

## ADDXFER\_CHK\_TO

### Description

This system variable returns the check number of the new check being transferred to (if the check number is changed) when called inside an XFER\_CHECK event.

Inside the ADD\_CHECK event, this system variable will return the check number of the check that is receiving the newly added check.

### Type/Size

N9

---

### **Syntax**

@ADDXFER\_CHK\_TO

### **Remarks**

- This system variable is Read-Only.
- This system variable is only valid in ADD\_CHECK or XFER\_CHECK SIM events.

## **ADDXFER\_GRP\_FROM**

### **Description**

This system variable returns the table group number of the check being transferred from when called inside an XFER\_CHECK event.

Inside the ADD\_CHECK event, this system variable will return the table group number of the check being added to the current check.

### **Type/Size**

N9

### **Syntax**

@ADDXFER\_GRP\_FROM

### **Remarks**

- This system variable is Read-Only.
- This system variable is only valid in ADD\_CHECK or XFER\_CHECK SIM events.

## **ADDXFER\_GRP\_TO**

### **Description**

This system variable returns the table group number of the new check being transferred to (if the check number is changed) when called inside an XFER\_CHECK event.

Inside the ADD\_CHECK event, this system variable will return the table group number of the check that is receiving the newly added check.

### **Type/Size**

N9

### **Syntax**

@ADDXFER\_GRP\_TO

### **Remarks**

- This system variable is Read-Only.
- This system variable is only valid in ADD\_CHECK or XFER\_CHECK SIM events.

---

## **ADDXFER\_RVC\_FROM**

### **Description**

This system variable returns the revenue center number of the check being transferred from when called inside an XFER\_CHECK event.

Inside the ADD\_CHECK event, this system variable will return the revenue center number of the check being added to the current check.

### **Type/Size**

N3

### **Syntax**

@ADDXFER\_RVC\_FROM

### **Remarks**

- This system variable is Read-Only.
- This system variable is only valid in ADD\_CHECK or XFER\_CHECK SIM events.

## **ADDXFER\_RVC\_TO**

### **Description**

This system variable returns the revenue center number of the new check being transferred to (if the check number is changed) when called inside an XFER\_CHECK event.

Inside the ADD\_CHECK event, this system variable will return the revenue center number of the check that is receiving the newly added check.

### **Type/Size**

N3

### **Syntax**

@ADDXFER\_RVC\_TO

### **Remarks**

- This system variable is Read-Only.
- This system variable is only valid in ADD\_CHECK or XFER\_CHECK SIM events.

## **ADDXFER\_TBL\_FROM**

### **Description**

This system variable returns the table number of the check being transferred from when called inside an XFER\_CHECK event.

Inside the ADD\_CHECK event, this system variable will return the table number of the check being added to the current check.

---

**Type/Size**

N9

**Syntax**

@ADDXFER\_TBL\_FROM

**Remarks**

- This system variable is Read-Only.
- This system variable is only valid in ADD\_CHECK or XFER\_CHECK SIM events.

**ADDXFER\_TBL\_TO****Description**

This system variable returns the table number of the new check being transferred to (if the check number is changed) when called inside an XFER\_CHECK event.

Inside the ADD\_CHECK event, this system variable will return the table number of the check that is receiving the newly added check.

**Type/Size**

N9

**Syntax**

@ADDXFER\_TBL\_TO

**Remarks**

- This system variable is Read-Only.
- This system variable is only valid in ADD\_CHECK or XFER\_CHECK SIM events.

**APPLICATIONNAME****Description**

This system variable holds the name of the extension application as configured in the database.

**Type/Size**

A\*

**Syntax**

@ApplicationName

**Remarks**

- This system variable is Read-Only.
- This variable can be used instead of hardcoding the application name in the script. Alternatively, it can be used to validate that the extension application was configured properly

---

## AUTHEMP

### Description

This system variable holds the object number of the authorizing employee when an authorization is occurring at a POS terminal.

### Type/Size

N9

### Syntax

@AuthEmp

### Remarks

- This system variable is Read-Only.
- This variable is only active in the “auth” event.

## AUTHEMP\_FNAME

### Description

This system variable holds the first name of the authorizing employee when an authorization is occurring at a POS terminal.

### Type/Size

A\*

### Syntax

@AuthEmp\_FName

### Remarks

- This system variable is Read-Only.
- This variable is only active in the “auth” event.

## AUTHEMP\_LNAME

### Description

This system variable holds the last name of the authorizing employee when an authorization is occurring at a POS terminal.

### Type/Size

A\*

### Syntax

@AuthEmp\_LName

### Remarks

- This system variable is Read-Only.
- This variable is only active in the “auth” event.

---

## AUTHTYPE

### Description

This system variable holds the type of authorization when an authorization is occurring at a POS terminal.

### Type/Size

N9

### Syntax

@AuthType

### Remarks

- This system variable is Read-Only.
- This variable is only active in the “auth” event.
- The number in this variable corresponds to the number of the role privilege bit that is being authorized.

## AUTOSVC

### Description

This system variable contains the sum of all auto service charges posted to the current guest check.

### Type/Size

\$12

### Syntax

@AUTOSVC

### Remarks

This system variable is Read-Only.

## AVAILABLEMEMORY

### Description

This system variable holds the amount of available memory available as reported by the .net framework.

### Type/Size

N

### Syntax

@AvailableMemory

### Remarks

- This system variable is Read-Only.
- This variable is a passthrough to @OpsContext.AvailableMemory

---

## **BOOTSERIALNUM**

### **Description**

This system variable is currently not set and is provided for backwards compatibility for older scripts.

### **Type/Size**

N9

### **Syntax**

@BOOTSERIALNUM

### **Remarks**

- This system variable is Read-Only.

## **BOOTSERIALSTR**

### **Description**

This system variable is currently not set and is provided for backwards compatibility for older scripts.

### **Type/Size**

N9

### **Syntax**

@BOOTSERIALSTR

### **Remarks**

- This system variable is Read-Only.

## **CASH\_DRAWER**

### **Description**

This system variable contains the currently assigned cash drawer.

### **Type/Size**

N1

### **Syntax**

@CASH\_DRAWER

### **Remarks**

- This system variable is Read-Only.
- If a cash drawer is assigned the value will be 1 or 2. The value will be 0 if no cash drawer is assigned.

---

## CENTER

### Description

This system variable contains the column number that is required to center text in an ISL-defined window.

### Type/Size

N9

### Syntax

@CENTER

### Remarks

- This system variable is Read-Only.
- @CENTER evaluates to -1.
- This system variable can be used as the column argument when specifying the **Display** command.

### Example

The following event procedure centers the text within an ISL-defined window:

```
event inq : 1
  window 4, 40
  display 1, @center, "In this window, all lines have "
  display 2, @center, "been centered to give it "
  display 3, @center, "that professional "
  display 4, @center, "look."
  waitforclear
endevent
```

### See Also

Display command

## CHANGE

### Description

This system variable is the amount of change due for an overtender.

### Type/Size

\$12

### Syntax

@CHANGE

### Remarks

- This system variable is Read-Only.
- This system variable is valid under only two conditions:
  - If in the TMED event
  - If the @TTLDUE system variable equals \$0.00

---

**See Also**

@TTLDUE system variable

**CHECKDATA****Description**

This system variable returns a string that contains a facsimile of a guest check created by the current transaction.

**Type/Size**

String: size depends on data

**Syntax**

@CHECKDATA

**Remarks**

- This data is Read-Only.
- The string may consist of zero or more lines that are separated by ASCII newlines, including print formatting characters specifying red ink or double-wide characters.
- The **MakeAscii** command can be used to strip out the print formatting characters in the string.
- This variable should only be accessed in a final\_tender event.

**See Also**

**MakeAscii** command

**CHGTIP****Description**

This system variable contains the charged tip for the associated tender in a TMED event.

**Type/Size**

\$12

**Syntax**

@CHGTIP

**Remarks**

- This system variable is Read-Only.
- Valid only in a TMED event.
- The @CHGTIP amount is included in the @SVC system variable.

---

## CHK

### Description

This system variable contains the object number of the Guest Check Printer assigned to the workstation.

### Type/Size

N9

### Syntax

@CHK

### Remarks

- This system variable is Read-Only.
- This system variable can be used as an argument to the **StartPrint** command.

### Example

The event procedure below starts a print job at the Guest Check Printer.

```
event inq : 1
  startprint @chk
    printline "this is a line"
  endprint
  if @printstatus = "Y"
    waitforclear "Print successful"
  else
    waitforclear "Print failed"
  endif
```

### See Also

- **StartPrint** command
- ISL Printing

## CHKINFOKEY

### Description

This system variable is used to set the key used for storing check info lines as extensibility detail.

### Type/Size

A

### Syntax

@ChkInfoKey

### Remarks

- The "check info lines" in Symphony are stored as extensibility detail in the check. When SaveChkInfo is called, OPS uses the ChkInfoKey value as a key to store the data in the check.
- If no key is specified it will be stored with a blank key.

---

## **CHK\_OPEN\_TIME**

### **Description**

This system variable returns a string containing the date and time that the current guest check was opened.

### **Type/Size**

A17

### **Syntax**

@CHK\_OPEN\_TIME

### **Remarks**

This system variable is Read-Only.

## **CHK\_OPEN\_TIME\_T**

### **Description**

This system variable returns the date and time that the current guest check was opened seconds since midnight January 1, 1970.

### **Type/Size**

N9

### **Syntax**

@CHK\_OPEN\_TIME\_T

### **Remarks**

This system variable is Read-Only.

## **CHK\_PAYMNT\_TTL**

### **Description**

This system variable returns the current payment total.

### **Type/Size**

\$12

### **Syntax**

@CHK\_PAYMNT\_TTL

### **Remarks**

This system variable is Read-Only.

## **CHK\_TTL**

### **Description**

This system variable returns the current check total.

---

**Type/Size**

\$12

**Syntax**

@CHK\_TTL

**Remarks**

This system variable is Read-Only.

**CKCSHR****Description**

This system variable contains the guest check cashier number.

**Type/Size**

N9

**Syntax**

@CKCSHR

**Remarks**

This system variable is Read-Only.

**CKCSHR\_NAME****Description**

This system variable contains the guest check cashier's check name.

**Type/Size**

A16

**Syntax**

@CKCSHR\_NAME

**Remarks**

This system variable is Read-Only.

**CKEMP****Description**

This system variable contains the number of the Check Employee, the operator who owns the current guest check.

**Type/Size**

N9

**Syntax**

@CKEMP

---

## Remarks

This system variable is Read-Only.

## Example

The following example is a standard message exchange between Symphony and a PMS:

```
event inq : 1
    var room_num : a4
    input room_num, "Enter Room Number"
    txmsg "charge_inq",@CKEMP,@CKNUM,@INDTTL,room_num

(charge_inq) is an // The first field
string // example of an identifying
process // that the POS might use to

    waitforrxmsg // message from the POS.
    endevent

    event rxmsg : charge_declined // This is one of the PMS
response

    var room_num : a4 // possibilities
    rxmsg room_num
    exitwitherror "Charge for room ", room_num," declined"
    endevent
```

## CKEMP\_CHKNAME

### Description

This system variable contains the check employee's check name, the operator who owns the current guest check.

### Type/Size

A16

### Syntax

@CKEMP\_CHKNAME

### Remarks

This system variable is Read-Only.

## CKEMP\_FNAME

### Description

This system variable contains the check employee's first name, the operator who owns the current guest check.

### Type/Size

A8

---

**Syntax**

@CKEMP\_FNAME

**Remarks**

This system variable is Read-Only.

**CKEMP\_CHKNAME****Description**

This system variable contains the check employee's last name, the operator who owns the current guest check.

**Type/Size**

A16

**Syntax**

@CKEMP\_LNAME

**Remarks**

This system variable is Read-Only.

**CKEMP\_TYPEDEF****Description**

This system variable is an array that contains the employee option bits for the check employee.

**Type/Size**

N1, array

**Syntax**

@CkEmp\_TypeDef

**Remarks**

- This system variable is Read-Only.

**CKID****Description**

This system variable contains the current guest check ID.

**Type/Size**

A32

**Syntax**

@CKID

**Remarks**

This system variable is Read-Only.

---

## CKNUM

### Description

This system variable contains the number assigned to the current guest check.

### Type/Size

N9

### Syntax

@CKNUM

### Remarks

This system variable is Read-Only.

### Example

See example of @CKEMP on page [7-24](#).

## CLIENT\_ONLINE

### Description

This system variable determines if a workstation is online.

### Type/Size

N1

### Syntax

@CLIENT\_ONLINE

### Remarks

This system variable is Read-Only.

### Example

```
Event Inq : 2
  if @client_online <> 0
    window 1,60
    display 1,2, "@client_online variable value is ",
      @client_online,". SAR Client is online!"
    waitforclear
  else
    window 1,60
    display 1,2, "@client_online variable value is ",
      @client_online,". SAR Client is offline!"
    waitforclear
  endif
EndEvent
```

## DATASTORE

### Description

This system variable contains the .net object reference to the extensibility datastore.

---

## Type/Size

object

## Syntax

@DataStore

## Remarks

- This system variable is Read-Only.
- Please consult the .net extensibility documentation for methods and properties available on this object.

## DAY

### Description

This system variable contains the current date.

### Type/Size

N2

### Syntax

@DAY

### Remarks

This system variable is Read-Only.

### Example

The following script will construct a *string\_variable* containing the current date in the form dd-mm-yy:

```
event inq : 1
    var date : a9

    call get_date_string
endevent
sub get_date_string
    var month_arr[12] : a3

    //Listing of all the months

    month_arr[1] = "JAN"
    month_arr[2] = "FEB"
    month_arr[3] = "MAR"
    month_arr[4] = "APR"
    month_arr[5] = "MAY"
    month_arr[6] = "JUN"
    month_arr[7] = "JUL"
    month_arr[8] = "AUG"
    month_arr[9] = "SEP"
    month_arr[10] = "OCT"
    month_arr[11] = "NOV"
    month_arr[12] = "DEC"
    format date as @DAY, "-", month_arr[@MONTH], "-", @YEAR
    // i.e., 10-NOV-01
endsub
```

---

**See Also**

@MONTH and @YEAR system variables

**DAYOFWEEK****Description**

This system variable contains the current day of the week.

**Type/Size**

N1

**Syntax**

@DayOfWeek

**Remarks**

- This system variable is Read-Only.
- This value corresponds to the System.DateTime.DayOfWeek value. Consult MSDN for details.

**DBVERSION****Description**

The current database version. For example, if a customer wants to take advantage of all elements in a variable-sized array, the customer may have to specify a more recent @DBVERSION value in the SIM script

**Type/Size**

N5

**Syntax**

@DBVERSION

**Remarks**

This system variable is Read-Only.

**DEBUGTRACE****Description**

This system variable is used to send debug information to the Visual Studio output window.

**Type/Size**

N1

**Syntax**

@DebugTrace

---

## Remarks

- If the POS is running in the Visual Studio debugger (when debugging .net extensibility applications, for example), setting this variable to 1 will cause SIM line debug information to be sent to the output window.
- This variable is useful in debugging SIM issues and is like legacy @trace.
- The default value is 0.

## DETAILSORTED

### Description

This system variable contains a “1” value if detail sorting is enabled or a “0” value if sorting is disabled.

### Type/Size

N9

### Syntax

@DETAILSORTED

### Remarks

This system variable is Read-Only.

### See Also

[UseSortedDetail](#) and [UseStdDetail](#) commands

## DSC

### Description

This system variable contains the total amount of discounts applied to the current guest check. This total is the sum of all percentage and amount discounts on the guest check.

### Type/Size

\$12

### Syntax

@DSC

### Remarks

This system variable is Read-Only.

## DSC\_OVERRIDE

### Description

When a manual discount is entered, a SIM ‘Discount’ script can decrease the amount of the discount by setting this variable to the desired discount amount.

### Type/Size

\$12

---

## Syntax

@DSC\_OVERRIDE

## Remarks

This system variable is Read-Only.

## DSCI

### Description

This system variable is an array that contains the discount itemizer totals posted to the current guest check.

### Type/Size

\$12

## Syntax

@DSCI[expression]

## Remarks

- This system variable is Read-Only.
- The array limits of the *expression* are from 1 to 16.
- This variable will return totals posted to the discount itemizer specified by the array index.
- This variable is similar to the @SI variable.

## DTLCHILDSELECTED

### Description

This system variable contains the detail link of the child item selected in the detail area.

### Type/Size

N9

## Syntax

@DTLCHILDSELECTED

## Remarks

- This system variable is Read-Only.
- See @DtISelected to get the parent item.
- If the parent is selected this value will be the detail link of the parent item.
- This value is the same as the @OpsContext.CurrentChildItem property.

## DTL\_DEFSEQ

### Description

This system variable contains the definition sequence number of a detail item.

---

### **Type/Size**

N3

### **Syntax**

@DTL\_DEFSEQ[*expression*]

### **Remarks**

- This system variable is Read-Only.
- The array limits for the expression are 1 to @NUMDTLT.

### **See Also**

**UseSortedDetail** and **UseStdDetail** commands, and @DETAILSORTED and @NUMDTLT system variables

## **DTL\_DETAILLINK**

### **Description**

This system variable is an array containing the detail link of a detail item on the current guest check.

### **Type/Size**

N9

### **Syntax**

@DTL\_DETAILLINK [*expression*]

### **Remarks**

- This system variable is Read-Only.

## **DTL\_DSC\_EMPL**

### **Description**

This system variable contains the employee number who is getting the employee meal discount for the specified detail entry.

### **Type/Size**

N9

### **Syntax**

@DTL\_DSC\_EMPL[*expression*]

### **Remarks**

- This system variable is Read-Only.
- The array limits for the expression are 1 to @NUMDTLT.

### **See Also**

**UseSortedDetail** and **UseStdDetail** commands, and @DETAILSORTED and @NUMDTLT system variables

---

## DTL\_DSCI

### Description

This system variable contains the discount itemizer value for the menu item detail class.

### Type Size

N9

### Syntax

@DTL\_DSCI[*expression*]

### Remarks

This system variable is Read-Only.

### See Also

**UseSortedDetail** and **UseStdDetail** commands, and @DETAILSORTED system variable

## DTL\_FAMGRP

### Description

This system variable is an array containing the family group of a menu item that is listed in the current guest check detail.

### Type/Size

N9

### Syntax

@DTL\_FMGRP[*expression*]

### Remarks

- The expression following the system variable is the menu item's detail number.
- The array limits are 1 to @NUMDTLT.
- This system variable is Read-Only.

### See Also

**UseSortedDetail** and **UseStdDetail** commands, and @DETAILSORTED and @NUMDTLT system variables

## DTL\_INDEX

### Description

Index of the detail which fired the SIM event, applicable to the following SIM events:

- EMON\_MI
- EMON\_MI\_VOID
- EMON\_MI\_RETURN
- EMON\_DSC
- EMON\_DSC\_VOID

- 
- EMON\_SVC
  - EMON\_SVC\_VOID
  - EMON\_TNDR
  - EMON\_TNDR\_VOID

**Type/Size**

N9

**Syntax**

@DTL\_INDEX

**Remarks**

- The array limits are 1 to @NUMDTLT.
- This system variable is Read-Only.

**See Also**

**UseSortedDetail** and **UseStdDetail** commands, and @DETAILSORTED and @NUMDTLT system variables

**DTL\_IS\_COMBO****Description**

This system variable is an array containing the combo status of a detail item on the current guest check.

**Type/Size**

N1

**Syntax**

@DTL\_IS\_COMBO [*expression*]

**Remarks**

- This system variable is Read-Only.
- The value is 1 if the detail is a main or side combo item.

**DTL\_IS\_COMBO\_MAIN****Description**

This system variable is an array containing the combo status of a detail item on the current guest check.

**Type/Size**

N1

**Syntax**

@DTL\_IS\_COMBO\_MAIN [*expression*]

---

**Remarks**

- This system variable is Read-Only.
- The value is 1 if the detail is a main combo item.

**DTL\_IS\_COMBO\_SIDE****Description**

This system variable is an array containing the combo status of a detail item on the current guest check.

**Type/Size**

N1

**Syntax**

@DTL\_IS\_COMBO\_SIDE [*expression*]

**Remarks**

- This system variable is Read-Only.
- The value is 1 if the detail is a side combo item.

**DTL\_IS\_COMBO\_PARENT****Description**

This system variable is an array containing the combo status of a detail item on the current guest check.

**Type/Size**

N1

**Syntax**

@DTL\_IS\_COMBO\_PARENT [*expression*]

**Remarks**

- This system variable is Read-Only.
- The value is 1 if the detail is a combo meal parent combo item.

**DTL\_IS\_COND[i]****Description**

This system variable is an array that determines if a Guest Check Menu Item is a condiment.

**Type/Size**

N1

**Syntax**

@DTL\_IS\_COND[*expression*]

---

**Remarks**

- The array limits are 1 to @NUMDTLT.
- This system variable is Read-Only.

**DTL\_IS\_ON\_HOLD****Description**

This system variable is an array containing the hold status of a detail item on the current guest check.

**Type/Size**

N1

**Syntax**

@DTL\_IS\_ON\_HOLD [*expression*]

**Remarks**

- This system variable is Read-Only.
- The value is 1 if the detail on hold.

**DTL\_IS\_VOID[i]****Description**

This system variable is set to "Y" if this detail item is a void entry. Otherwise, the variable is set to "N."

**Type/Size**

N1

**Syntax**

@DTL\_IS\_VOID

**Remarks**

This system variable is Read-Only.

**DTL\_MAJGRP****Description**

This system variable is an array containing the major group of a menu item that is listed in the current guest check detail.

**Type/Size**

N9

**Syntax**

@DTL\_MAJGRP[*expression*]

---

## Remarks

- The expression following the system variable is the menu item's detail number.
- The array limits are 1 to @NUMDTLT.
- This system variable is Read-Only.

## See Also

**UseSortedDetail** and **UseStdDetail** commands, and @DETAILSORTED and @NUMDTLT system variables

## DTL\_MLVL

### Description

This system variable is an array containing the Main Menu Level (1-8) of a detail item on the current guest check.

### Type/Size

N1

### Syntax

@DTL\_MLVL[*expression*]

## Remarks

- This system variable is Read-Only.
- The array limits for the expression are 1 to @NUMDTLT.

## See Also

**UseSortedDetail** and **UseStdDetail** commands, and @DETAILSORTED and @NUMDTLT system variables

## DTL\_NAME

### Description

This system variable is an array containing the name of a detail item on the current guest check.

### Type/Size

A20

### Syntax

@DTL\_NAME[*expression*]

## Remarks

- This system variable is Read-Only.
- The array limits for the expression are 1 to @NUMDTLT.
- The first name of menu items will be returned.

---

**See Also**

**UseSortedDetail** and **UseStdDetail** commands, and @DETAILSORTED and @NUMDTLT system variables

**DTL\_OBJNUM****Description**

This system variable is an array containing the object number of a detail item on the current guest check.

**Type/Size**

N9

**Syntax**

@DTL\_OBJNUM[*expression*]

**Remarks**

- This system variable is Read-Only.
- The array limits for the expression are 1 to @NUMDTLT.

**Example**

See the example for @DTL\_MLVL on page 7-37.

**See Also**

**UseSortedDetail** and **UseStdDetail** commands, and @DETAILSORTED and @NUMDTLT system variables

**DTL\_PLVL****Description**

This system variable is an array containing the price level (1-8) of a menu item on the current guest check.

**Type/Size**

N1

**Syntax**

@DTL\_PLVL[*expression*]

**Remarks**

- This system variable is Read-Only.
- The array limits for the expression are 1 to @NUMDTLT.

**See Also**

**UseSortedDetail** and **UseStdDetail** commands, and @DETAILSORTED and @NUMDTLT system variables

---

## DTL\_PMSLINK

### Description

This system variable is an array containing the PMS link (1-4) assigned to a detail item on the current guest check.

### Type/Size

N2

### Syntax

@DTL\_PMSLINK[*expression*]

### Remarks

- This system variable is Read-Only.
- The array limits for the expression are 1 to @NUMDTLT.
- The PMS Link is defined in the RVC Parameters module.

### See Also

**UseSortedDetail** and **UseStdDetail** commands, and @DETAILSORTED and @NUMDTLT system variables

## DTL\_PRICESEQ

### Description

This system variable is an array containing the price sequence number (0-64) of a detail item on the current guest check.

### Type/Size

N3

### Syntax

@DTL\_PRICESEQ[*expression*]

### Remarks

- This system variable is Read-Only.
- The array limits for the expression are 1 to @NUMDTLT.

### See Also

**UseSortedDetail** and **UseStdDetail** commands, and @DETAILSORTED and @NUMDTLT system variables

## DTL\_QTY

### Description

This system variable is an array containing the quantity of a detail item on the current guest check.

---

### **Type/Size**

N5

### **Syntax**

@DTL\_QTY[*expression*]

### **Remarks**

- This system variable is Read-Only.
- The array limits for the expression are 1 to @NUMDTLT.

### **See Also**

**UseSortedDetail** and **UseStdDetail** commands, and @DETAILSORTED and @NUMDTLT system variables

## **DTL\_SEAT**

### **Description**

This system variable is an array containing the object number of the detail item assigned to a seat number.

### **Type/Size**

N5

### **Syntax**

@DTL\_SEAT[*expression*]

### **Remarks**

- This system variable is Read-Only.
- The array limits for the expression are 1 to @NUMDTLT.

### **See Also**

**UseSortedDetail** and **UseStdDetail** commands, and @DETAILSORTED and @NUMDTLT system variables

## **DTLSELECTED**

### **Description**

This system variable contains the detail link of the parent item selected in the detail area.

### **Type/Size**

N9

### **Syntax**

@DTLSELECTED

### **Remarks**

- This system variable is Read-Only.

- 
- This value is the same as the @OpsContext.CurrentParentItem property.

## **DTL\_SLSI**

### **Description**

This system variable contains the sales itemizer value for the menu item detail class.

### **Type/Size**

N9

### **Syntax**

@DTL\_SLSI[*expression*]

### **Remarks**

This system variable is Read-Only.

### **See Also**

**UseSortedDetail** and **UseStdDetail** commands, and @DETAILSORTED system variable

## **DTL\_SLVL**

### **Description**

This system variable is an array containing the Sub Menu Level (1-8) of a detail item on the current guest check.

### **Type/Size**

N1

### **Syntax**

@DTL\_SLVL[*expression*]

### **Remarks**

- This system variable is Read-Only.
- The array limits for the expression are 1 to @NUMDTLT.

### **Example**

See the example for @DTL\_MLVL on page 7-37.

### **See Also**

**UseSortedDetail** and **UseStdDetail** commands, and @DETAILSORTED and @NUMDTLT system variables

## **DTL\_STATUS**

### **Description**

This system variable is an array containing the status of a detail item on the current guest check.

---

### **Type/Size**

A12

### **Syntax**

@DTL\_STATUS[*expression*]

### **Remarks**

- This system variable is Read-Only.
- The array limits for the expression are 1 to @NUMDTLT.
- The value returned is formatted in hexadecimal digits.

### **See Also**

**UseSortedDetail** and **UseStdDetail** commands, and @DETAILSORTED and @NUMDTLT system variables

## **DTL\_SVC\_LINK**

### **Description**

This system variable is the current detail's stored value card link, as stored in the check detail.

### **Type/Size**

N9

### **Syntax**

@DTL\_SVC\_LINK[*expression*]

### **Remarks**

- This system variable is Read-Only.
- The array limits for the expression are 1 to @NUMDTLT.

### **See Also**

**UseSortedDetail** and **UseStdDetail** commands, and @DETAILSORTED and @NUMDTLT system variables

## **DTL\_SVC\_TYPE**

### **Description**

This system variable is the current detail's stored value card type, as stored in the check detail.

### **Type/Size**

N9

### **Syntax**

@DTL\_SVC\_TYPE[*expression*]

---

## Remarks

- This system variable is Read-Only.
- The array limits for the expression are 1 to @NUMDTLT.

## See Also

**UseSortedDetail** and **UseStdDetail** commands, and @DETAILSORTED and @NUMDTLT system variables

## DTL\_SVCI

### Description

This system variable contains the service charge itemizer value for the menu item detail class.

### Type/Size

N9

### Syntax

@DTL\_SVCI[*expression*]

### Remarks

This system variable is Read-Only.

### See also

**UseSortedDetail** and **UseStdDetail** commands, and @DETAILSORTED system variable

## Dtl\_TaxTtl

### Description

This system variable is an array containing the tax total of a detail item on the current guest check.

### Type/Size

\$

### Syntax

@Dtl\_TaxTtl [*expression*]

### Remarks

- This system variable is Read-Only.
- This value is calculated for the referenced detail. The sum of all detail tax totals is not guaranteed to balance with the summary tax total.

## DTL\_TAXTYPE

### Description

This system variable contains the tax types that were active when the corresponding menu item, service charge, or discount detail item was ordered.

---

### Type/Size

A2

### Syntax

@DTL\_TAXTYPE[*expression*]

### Remarks

- This system variable is Read-Write.
- This system variable is represented as a two-digit hex field, ranging from 00 to FF. Each bit corresponds to the tax type. For example, 80 corresponds to tax type 1.

### See Also

UseSortedDetail and UseStdDetail commands, and @DETAILSORTED system variable

## DTL\_TIMED\_FIRE\_TIME

### Description

This system variable is an array containing the timed fire time of a detail item on the current guest check.

### Type/Size

N9

### Syntax

@DTL\_TIMED\_FIRE\_TIME [*expression*]

### Remarks

- This variable can be used to set the timed fire time of a detail item.

## DTL\_TTL

### Description

This system variable is an array containing the total of a detail item on the current guest check.

### Type/Size

\$12

### Syntax

@DTL\_TTL[*expression*]

### Remarks

- This system variable is Read-Only.
- The array limits for the expression are 1 to @NUMDTLT.

---

## Example

This example is part of a script that checks a current guest check for a certain number of menu items. If four menu items are found, the script will call a subroutine that prints a coupon (call `print_coupon`) and a subroutine that determines how many items are on the check (call `check_grill_list( objnum)`); these subroutine scripts are not shown.

```
event tmed : *
  var dtl_cnt : n3
  var num_grill_items : n3 = 6
  var grill_item[ num_grill_items ] : n5 var grill_hit : n3
  var objnum : n5

  grill_item[ 1 ] = 1501
  grill_item[ 2 ] = 1510
  grill_item[ 3 ] = 1520
  grill_item[ 4 ] = 1530
  grill_item[ 5 ] = 1540
  grill_item[ 6 ] = 1550

  // look through the check, have we ordered 4 grill items
  for dtl_cnt = 1 to @numdtlt
    if @dtl_type[ dtl_cnt ] = "M" AND @dtl_ttl[ dtl_cnt ] > 0
      objnum = @dtl_objnum[ dtl_cnt ]
      call check_grill_list( objnum)
    endif
    if grill_hit >= 4 c
      all print_coupon
    endif
  endif
endevent
```

## See Also

`UseSortedDetail` and `UseStdDetail` commands, and `@DETAILSORTED` and `@NUMDTLT` system variables

## DTL\_TYPE

### Description

This system variable is an array containing the detail type of an item on the current guest check.

### Type/Size

A1

### Syntax

`@DTL_TYPE[expression]`

### Remarks

- This system variable is Read-Only.
- The array limits for the expression are 1 to `@NUMDTLT`.
- The detail type will be one of the following:

#### Table 17 Item Detail Types

Type	Description
I	Check Information Detail
M	Menu Item
D	Discount
S	Service Charge
T	Tender/Media
R	Reference Number
C	CA Detail

### Example

See the example for @DTL\_MLVL on page 7-37.

### See also

UseSortedDetail and UseStdDetail commands, and @DETAILSORTED and @NUMDTLT system variables

## DTL\_TYPEDEF

### Description

This system variable returns the detail item type definition for discounts (D), menu items (M), service charges (S), and tenders (T).

### Type/Size

Size depends on the detail type:

**Table 18 Detail Types and Corresponding Sizes**

Detail Type	Size
Discount	A6
Menu Item	A12
Service Charge	A12
Tender	A22
CA	A2

### Syntax

@DTL\_TYPEDEF[*expression*]

### Remarks

- This system variable is Read-Only.
- The type definition is returned as a hex string. If the discount type definition is E78D, then @dtl\_typedef[ ] for that discount will be "E78D," or an A4.
- For menu items, this variable returns the type definition field from the revenue center (RVC) level menu item class module associated with that menu item.

- For discounts, service charges, and tender media detail items, this variable returns the type definition field from the property level modules.
- For CA detail, this variable returns the type definition from the Check Detail.

### Example

This piece of ISL code will scan the detail and display any open-priced menu items or open discount items.

```

event inq:1
  var i:N5
  for i = 1 to @numdtlt // loop through

all detail

      if @dtl_type[i] = "M" AND bit( @dtl_typedef[i], 1 ) <> 0 // check
if M and bit 1 are set in the M class typedef
  waitforclear "Item ", i, " is open priced MI" // check if D
  and bit 1 are set in the D typedef
  elseif @dtl_type[i] = "D" AND bit( @dtl_typedef[i], 1 ) <> 0
  waitforclear "Item ", i, " is open DSC"
  endif
endfor
endevent

```

### See Also

**UseSortedDetail** and **UseStdDetail** commands, and @DETAILSORTED and @DTL\_TYPE system variables

## DWOFF

### Description

This system variable returns printed text to single-wide characters (default) if the @DWON system variable was used to switch text to double-wide characters.

### Type/Size

A1

### Syntax

@DWOFF

### Remarks

- This system variable is Read-Only.
- @DWON is also known as a print directive and can be an argument of the **Printline** command.
- All new lines of text print as single-wide characters.

### Example

The ISL statement below prints "Print line" in double-wide characters and red ink, then turns off these print directives.

```

startprint printer
  printline "-----"
  printline @dwon, @redon, "chit"

```

---

```
printline          "-----"  
@dwoff, @redoff  
endprint
```

### See Also

- @DWON system variable; **Printline** command
- "ISL Printing"

## DWON

### Description

This system variable prints the expression that follows it in double-wide characters.

### Type/Size

A1

### Syntax

@DWON

### Remarks

- This system variable is Read-Only.
- @DWON is also known as a print directive and can be an argument of the **Printline** command.
- Double- and single-wide characters may be mixed on the same line.

### Example

The ISL statement below will print "Print line" in double-wide characters and red ink.

```
Printline @dwon, @redon, "Print line" //prints double-wide in red
```

### See Also

- @DWON system variable; **Printline** command
- "ISL Printing"

## EMPLDISCOUNT

### Description

In a discount event, this variable is the number of the employee discount.

### Type/Size

N9

### Syntax

@EMPLDISCOUNT

### Remarks

This system variable is Read-Only.

---

## EMPLDISCOUNTEMPL

### Description

In a discount event, this variable is the employee number of the discount receiving the employee discount.

### Type/Size

N9

### Syntax

@EMPLDISCOUNTEMPL

### Remarks

This system variable is Read-Only.

## EMPLOPT

### Description

This system variable is an array containing the setting of SIM Employee Options #1 through #8, which are defined for the employee who initiated the event.

### Type/Size

N1

### Syntax

@EMPLOPT[*expression*]

### Remarks

- This system variable is Read-Only.
- The array limits for the expression are from 1 to 8.
- The value returned by the system variable will be the setting of the privilege option code: "0" for OFF, or "1" for ON.
- These values correspond to ISL Employee Options #1 - #8 in Employee Classes | Privileges.
- This system variable can be used to control access to specific events in scripts. For example, to prevent certain employees from initiating a particular event, disable one of the eight available privilege option codes. Within the event, include an ISL statement in which the setting of the corresponding privilege option code is checked. Thus, if the setting is disabled, for example, at this point in the script, an error message is issued, or the employee is directed to take some other action instead of performing the task.

---

## EPOCH

### Description

This system variable contains the number of seconds that have expired since midnight January 1, 1970, the EPOCH Time.

### Type/Size

N9

### Syntax

@EPOCH

### Remarks

This system variable is Read-Only.

## ERRORMESSAGE

### Description

This system variable contains the error message text in the “errmsg” event.

### Type/Size

A

### Syntax

@ERRORMESSAGE

### Remarks

- This system variable is Read-Only.

## EVENTARGUMENTS

### Description

This system variable contains reference to the EventMonitorArgs object associated with the currently executing event.

### Type/Size

object

### Syntax

@EVENTARGUMENTS

### Remarks

- This system variable is Read-Only.
- This object is the same that is passed to .net extensibility. (Both share the same EventMonitorArgs facility.)

---

## EVENTID

### Description

This system variable is the string that represents the ID of the event being raised. The text is the same as the second parameter in an EVENT statement.

### Type/Size

A32

### Syntax

@EVENTID

## EVENTNAME

### Description

This system variable contains the event ID associated with the currently executing event.

### Type/Size

A

### Syntax

@EVENTNAME

### Remarks

- This system variable is Read-Only.
- This variable allows subroutines common across many events to distinguish which event they are in.

## EVENTTYPE

### Description

This system variable is the string that represents the type of event being raised (an inquire event is "INQ"). The text is the same as the first parameter in an EVENT statement.

### Type/Size

A32

### Syntax

@EVENTTYPE

## FIELDSTATUS

### Description

This system variable contains the Input Status Flag, which is set automatically by the ISL after any of the **WindowEdit** or **WindowInput** command is issued in an event procedure.

---

## Type/Size

A1

## Syntax

@FIELDSTATUS

## Remarks

- This system variable is Read-Only.
- The Input Status Flag will be either of the following settings:

**Table 19 Input Status Flags**

Flag	Description
Y	indicates that all fields were entered by the operator
N	indicates that some, not all, of the fields were entered by the operator

- This system variable will be set to "Y" if each **DisplayInput** variable has been entered using the **WindowEdit** or **WindowInput** command; otherwise, the system variable will be set to "N".

## Example

In the example below, three variables have been defined for the **DisplayInput** command, and all have been set by the user; consequently, @FIELDSTATUS is set to "Y". If the user entered data for only two of the three fields,

@FIELDSTATUS would be set to "N". Thus, accessing this system variable is most logical after issuing either the **WindowEdit** or **WindowInput** command.

```
event inq : 1
  var data[3] : a20
  window 3, 40
  displayinput 1, 1, data[1], "Enter data 1"
  displayinput 2, 1, data[2], "Enter data 2"
  displayinput 3, 1, data[3], "Enter data 3"
  windowinput
  if @fieldstatus = "Y"
    display 2, @center, "All fields entered"
  else
    display 2, @center, "Some fields not entered"
  endif
  waitforclear
endevent
```

## See Also

**WindowEdit[WithSave]** and **WindowInput[WithSave]** commands

## FILE

### Description

This system variable contains the file name of the line of the script where the @file system variable is referenced.

---

### **Type/Size**

A

### **Syntax**

@FILE

### **Remarks**

- This system variable is Read-Only.
- This can be useful for debug purposes.

## **FILELINEMARKER**

### **Description**

This system variable contains the file name/line number of the line of the script where the @filelinemarker system variable is referenced.

### **Type/Size**

A

### **Syntax**

@FILELINEMARKER

### **Remarks**

- This system variable is Read-Only.
- An example of this variable's value is "myscript.isl:123", where 123 is the current line number.
- This can be useful for debug purposes.

## **FILE\_BFRSIZE**

### **Description**

This system variable is a user-definable variable that the ISL sets when it expects to read lines greater than 2048 bytes in an open file.

### **Type/Size**

N9

### **Syntax**

@FILE\_BFRSIZE

### **Remarks**

This user-definable variable has Read-Write attributes.

### **Example**

If the script is reading lines from a file which is 4K in length, for example, then the script should execute the following line:

```
@FILE_BFRSIZE = 4096
```

---

## See Also

[ISL File Input/Output Commands](#)

## FILE\_ERRNO

### Description

This system variable is where a Standard Error Number value is saved after every file input/output operation initiated during an event procedure.

### Type/Size

N6

### Syntax

@FILE\_ERRNO

### Remarks

This system variable has Read-Write attributes.

- The value will either be 0 or non-zero: 0 means no error occurred, and non-zero indicates an error has occurred. The following table contains the more common non-zero error code values that may be returned by the ISL File I/O commands:

**Table 20 Common Non-Zero Error Codes Returned by ISL File I/O Commands**

Error Name	Error Number Value	Description
EACCES	13	Permission denied
EAGAIN	11	No more processes
EDEADLK	45	Deadlock condition
EFBIG	27	File too large
EIO	5	I/O error
EISDIR	21	Is a directory
ENOLINK	67	The link has been saved
ENXIO	6	No such device or address
EROFS	30	Read only file system
ESPIPE	29	Illegal seek

The following table lists the possible errors that the File I/O commands may receive:

**Table 21 Possible Errors Received by the File I/O Commands**

File Commands	Error Names
FOpen	EACCES, EAGAIN, EISDIR, ENXIO, and EROFS
FClose	ENOLINK

FLock	EACCES, EDEADLK, and ENOLINK
FRead, FReadBfr, and FReadLn	EIO and ENOLINK
FSeek	ESPIPE
FUnlock	EACCES and ENOLINK
FWrite, FWriteBfr, and FWriteLn	EFBIG and ENOLINK

- The @FILE\_ERRSTR system variable contains the error message text corresponding to the Error Code. This system variable can be used to display that text if the error occurs.

### See Also

- @FILE\_ERRSTR system variable
- [ISL File Input/Output Commands](#)

## FILE\_ERRSTR

### Description

This system variable returns a string containing the Standard Error that occurred during a file input/output operation. The string corresponds to the error code saved in the @FILE\_ERRNO system variable.

### Type/Size

A80

### Syntax

@FILE\_ERRSTR

### Remarks

- This system variable is Read-Only.
- This string can be used to display the actual error message text, based on the number value saved in the @FILE\_ERRNO system variable. Displaying this error message can make it easier to troubleshoot problems with file I/O operations and to verify whether the script was successful in executing a file I/O operation. For example, assume an attempt is made to write to a file with the FWrite command and the error code 5 is saved in @FILE\_ERRNO. If this file I/O operation is unsuccessful, specifying the @FILE\_ERRSTR system variable will allow the string "I/O error" to be displayed.
- To determine the string that will be displayed, refer to Table 21 Possible Errors Received by the File I/O Commands.

### Example

The following script opens a file. If the operation is unsuccessful, an error message will display the cause of the error.

```
event inq : 1
```

---

```
var fn : N5
fopen fn, "myfile.dat", read
if fn = 0
    errormessage @FILE_ERRSTR
    exitcontinue endif
endevent
```

### See Also

@FILE\_ERRNO system variable

## FILE\_SEPARATOR

### Description

This system variable stores the user-defined field separator to be used in all file input/output operations.

### Type/Size

A1

### Syntax

@FILE\_SEPARATOR

### Remarks

- This system variable has Read-Write attributes.
- In normal ISL File I/O operations, ISL assumes the comma (,) character is the field separator. But if a different field separator is needed, the script must change the @FILE\_SEPARATOR system variable.
- If a string with more than one character is assigned to the variable, then only the first character will be used.
- When @FILE\_SEPARATOR changes the field separator, all subsequent field operations will use the new field separator until the @FILE\_SEPARATOR variable is changed.

## FILTER\_ACTIVE

### Description

This system variable is set to "Y" if seat filtering is active. Otherwise, the variable is set to "N."

### Type/Size

A1

### Syntax

@FILTER\_ACTIVE

### Remarks

This system variable is Read-Only.

---

## **FILTER\_MASK**

### **Description**

This system variable is the current seat filter mask.

### **Type/Size**

A8

### **Syntax**

@FILTER\_MASK

### **Remarks**

This system variable is Read-Only.

## **GRPNUM**

### **Description**

This system variable contains the table ID group number assigned to the current guest check.

### **Type/Size**

N9

### **Syntax**

@GRPNUM

### **Remarks**

This system variable is Read-Only.

## **GST**

### **Description**

This system variable contains the number of guests assigned to the current guest check.

### **Type/Size**

N5

### **Syntax**

@GST

### **Remarks**

This system variable is Read-Only.

### **See Also**

@GSTRMNG system variable

---

## GSTRMNG

### Description

This system variable contains the number of guests remaining on the current guest check after it has been prorated.

### Type/Size

N5

### Syntax

@GSTRMNG

### Remarks

- This system variable is Read-Only.
- This system variable must be used within an Event Tmed only.
- This system variable should be used in tandem with the @GSTTHISTENDER system variable and the **Prorate** command to determine the remaining guest count on a prorated guest check. In a PMS environment, the PMS may require that the guest count on a check be prorated. For example, if five guests are on a \$100 check, and \$60 ( $\$20 * 3 = \$60$ ) is tendered, the PMS assumes that three of the guests have settled. A typical PMS posting scenario will include a step for prompting the operator to enter the number of guests for the current posting, to associate the guests with the tender.

ISL provides the same capability. However, implementing this function via a SIM Interface requires 1) knowing the number of guests remaining on the check, and 2) informing Symphony of the number of guests to associate with a tender. Use @GSTRMNG to get the number of guests remaining, then use this value as a condition for requiring an operator to enter the number of guests during a tendering transaction before posting to the PMS. See the example below.

- When the **Prorate** command is active and a tender/media event occurs, @GSTRMNG will contain the number of guests yet to post. When the first tender is posted, @GSTRMNG will be equal to all the guests on the check. When posting subsequent tenders, @GSTRMNG will be the number of guests remaining. For example, if there are five guests on a check, @GSTRMNG will be five. But if three are prorated with the first tender, @GSTRMNG will be two upon the second round of proration.

### Example

The following subroutine implements guest count proration:

```
sub prorata_guests
  var num_guests : n5
  prorata

  // If there are still guests left on this check to be prorated,
  // ask the user how many guests this check.
if @gstrmng > 0
  forever
    input number_guests, "Number of guests this tender?"
    if number_guests > @gstrmng
```

---

```

        errormessage "Max guests is ", @gstrmng
    else
        break
    endif
endfor

// Prorate this many many guests for this tender. Next time around,
// this many guests will be subtracted from @gstrmng.

    @gstthistender = num_guests
endif
endsub

```

### See Also

- @GST and @GSTTHISTENDER system variables
- **Prorate** command

## GSTTHISTENDER

### Description

This system variable contains the number of guests on the current guest check associated with a split tender when proration is active.

### Type/Size

N5

### Syntax

@GSTTHISTENDER

### Remarks

- This system variable has Read-Write attributes.
- This system variable must be used within an Event Tmed only.
- Use this system variable in tandem with the @GSTRMNG system variable and **Prorate** command to properly prorate guest count for a PMS via a SIM Interface. When set, @GSTTHISTENDER will define the number of guests that are prorated during a tendering transaction. For explanation, see the detail description of @GSTRMNG.
- If the PMS requires prorated guest counts when posting tenders, the SIM script must set @GSTTHISTENDER.

### Example

See example for @GSTRMNG on page 7-58.

### See Also

- @GST and @GSTRMNG system variables
- **Prorate** command

---

## GUID

### Description

This system variable returns a string array with the GUID of the current check.

### Type/Size

A40

### Syntax

@GUID

### Remarks

This system variable is Read-Only.

## HEADER

### Description

This system variable is string array with 48 elements. The @HEADER[] array is unique to each event. This means that each event can begin writing to the array starting at index 1, rather than at the next available index.

### Type/Size

A32

### Syntax

@HEADER[*expression*]

### Remarks

- This system variable is Read-Write.
- This system variable is only used with the **Print\_Header** Event. All transaction system variables are still valid in this event. User input is still allowed, as are file operations and display manipulation. See page [8-37](#).

### See Also

**Print\_Header** and **Print\_Trailer** events and **@TRAILER** system variable.

## HOUR

### Description

This system variable contains the current hour of the day.

### Type/Size

N2

### Syntax

@HOUR

---

## Remarks

- This system variable is Read-Only.
- The value returned will be from 0 to 23.
- The hour will be in Military Time format. For example, 2 pm will be returned as "14."

## IGNORE\_PRMT

### Description

This system variable must be set to a non-zero value to enable the keyboard macro command to pass the [Enter] key to general operator prompts.

### Type/Size

N5

### Syntax

@IGNORE\_PRMT=integer

### Remarks

This system variable has Read-Write attributes.

## INEDITCLOSEDCHECK

### Description

This system variable is set to "1" if this is an edit closed check entry. Otherwise, the variable is set to "0."

### Type/Size

N1

### Syntax

@INEDITCLOSEDCHECK

### Remarks

This system variable is Read-Only and is related to the Symphony function "Adjust Closed Check".

## INPUTSTATUS

### Description

This system variable sets the User Input Status Flag if the **ContinueOnCancel** command is executed.

### Type/Size

N9

### Syntax

@INPUTSTATUS

---

## Remarks

- This system variable is Read-Only.
- The User Input Status Flag will be set to one of the following:

**Table 22 User Input Status Flags**

Flag	Description
0	indicates that the user canceled any input by pressing [Cancel]
1	indicates that the user entered all valid

## See Also

ContinueOnCancel command

## INREOPENCLOSEDCHECK

### Description

This system variable is set to "1" if this is a reopen closed check entry. Otherwise, the variable is set to "0."

### Type/Size

N1

### Syntax

@INREOPENCLOSEDCHECK

### Remarks

This system variable is Read-Only.

## INSTANDALONEMODE

### Description

This system variable determines if the workstation is offline.

### Type/Size

N1

### Syntax

@INSTANDALONEMODE

### Remarks

This system variable is Read-Only.

### Example

```
Event Inq : 2
  if @InStandaloneMode <> 0
    window 1,65
    display 1,2, "@InStandaloneMode variable value is ",
      @InStandaloneMode, ". SAR Client is offline!"
    waitforclear
```

---

```
    else
      window 1,65
      display 1,2, "@InStandaloneMode variable value is ",
        @InStandaloneMode, ". SAR Client is online!"
      waitforclear
    endif
  EndEvent
```

## ISJOURNALPRINT

### Description

This system variable contains the status of the current print job when header and trailer lines are being formatted by SIM.

### Type/Size

N1

### Syntax

@ISJOURNALPRINT

### Remarks

- This system variable is Read-Only.
- This value is 1 when formatting for a journal printer, 0 otherwise.
- This variable is only valid during header/trailer events.
- This variable can be used to change the output when formatting for the journal.

## ISUNICODE

### Description

This system variable is set to "Y" if Unicode characters are supported. Otherwise, the variable is set to "N."

### Type/Size

N1

### Syntax

@ISUNICODE

### Remarks

This system variable is Read-Only.

## JNL

### Description

This system variable contains the printer object number of the workstation's report printer.

### Type/Size

N9

---

## Syntax

@JNL

## Remarks

- This system variable is Read-Only.

## KEY\_CANCEL

### Description

This system variable contains the [Cancel] key.

### Type/Size

Key

## Syntax

@KEY\_CANCEL

## Remarks

- This system variable is Read-Only.
- This system variable is designed for checking keystrokes from the **InputKey** command and setting keyboard macros with the **LoadKyBdMacro** command.

## Example

The script below tests that the [Cancel] key was pressed by using @KEY\_CANCEL. The operator is prompted to enter a number between 1 and 9. However, if either the [Clear] or [Cancel] key is pressed instead, the script will terminate.

```
event inq : 4
  var key_pressed : key           // Hold the function key pressed
  var data : a10 // Hold the number chosen

  forever
    inputkey key_pressed, data, "Type a Number then Enter, Clear to Exit" if
    key_pressed = @KEY_CLEAR
      exitcontinue
    elseif key_pressed = @KEY_CANCEL
      exitcontinue
    elseif key_pressed = @KEY_ENTER
      if data < 0 and data <=10
        waitforclear "You chose ", data, ". Press Clear."
      else
        errormessage "Choose a number between 1 and 10, then press Enter."
      endif
    endif
  endfor
endevent
```

## See Also

**InputKey** command

---

## KEY\_CLEAR

### Description

This system variable contains the [Clear] key.

### Type/Size

Key

### Syntax

@KEY\_CLEAR

### Remarks

- This system variable is Read-Only.
- This system variable is designed for checking keystrokes from the **InputKey** command and setting keyboard macros with the **LoadKyBdMacro** command.

### Example

See the example for @KEY\_CANCEL on page 7-63.

### See Also

**InputKey** and **LoadKyBdMacro** commands

## KEY\_DOWN\_ARROW

### Description

This system variable contains the [Down Arrow] key.

### Type/Size

Key

### Syntax

@KEY\_DOWN\_ARROW

### Remarks

- This system variable is Read-Only.
- This system variable is designed for checking keystrokes from the **InputKey** command and setting keyboard macros with the **LoadKyBdMacro** command.

### See Also

**InputKey** and **LoadKyBdMacro** commands

KEY\_END

### Description

This system variable contains the [End] key.

### Type/Size

Key

---

### Syntax

@KEY\_END

### Remarks

- This system variable is Read-Only.
- This system variable is designed for checking keystrokes from the **InputKey** command and setting keyboard macros with the **LoadKyBdMacro** command.

### See Also

**InputKey** and **LoadKyBdMacro** commands

## KEY\_ENTER

### Description

This system variable contains the [Enter] key.

### Type/Size

Key

### Syntax

@KEY\_ENTER

### Remarks

- This system variable is Read-Only.
- This system variable is designed for checking keystrokes from the **InputKey** command and setting keyboard macros with the **LoadKyBdMacro** command.

### Example

See the example for @KEY\_CANCEL on page 7-63.

### See Also

**InputKey** and **LoadKyBdMacro** commands

## KEY\_EXIT

### Description

This system variable contains the [Exit] key.

### Type/Size

Key

### Syntax

@KEY\_EXIT

### Remarks

- This system variable is Read-Only.
- This system variable is designed for checking keystrokes from the **InputKey** command and setting keyboard macros with the **LoadKyBdMacro** command.

---

### See Also

**InputKey** and **LoadKyBdMacro** commands

## KEY\_HOME

### Description

This system variable contains the [Home] key.

### Type/Size

Key

### Syntax

@KEY\_HOME

### Remarks

- This system variable is Read-Only.
- This system variable is designed for checking keystrokes from the **InputKey** command and setting keyboard macros with the **LoadKyBdMacro** command.

### See Also

**InputKey** and **LoadKyBdMacro** commands

## KEY\_LEFT\_ARROW

### Description

This system variable contains the [Left Arrow] key.

### Type/Size

Key

### Syntax

@KEY\_LEFT\_ARROW

### Remarks

- This system variable is Read-Only.
- This system variable is designed for checking keystrokes from the **InputKey** command and setting keyboard macros with the **LoadKyBdMacro** command.

### See Also

**InputKey** and **LoadKyBdMacro** commands

## KEY\_PAGE\_DOWN

### Description

This system variable contains the [Page Down] key.

### Type/Size

Key

---

## Syntax

@KEY\_PAGE\_DOWN

## Remarks

- This system variable is Read-Only.
- This system variable is designed for checking keystrokes from the **InputKey** command and setting keyboard macros with the **LoadKyBdMacro** command.

## See Also

**InputKey** and **LoadKyBdMacro** commands

## KEY\_PAGE\_UP

### Description

This system variable contains the [Page Up] key.

### Type/Size

Key

## Syntax

@KEY\_PAGE\_UP

## Remarks

- This system variable is Read-Only.
- This system variable is designed for checking keystrokes from the **InputKey** command and setting keyboard macros with the **LoadKyBdMacro** command.

## See Also

**InputKey** and **LoadKyBdMacro** commands

## KEY\_RIGHT\_ARROW

### Description

This system variable contains the [Right Arrow] key.

### Type/Size

Key

## Syntax

@KEY\_RIGHT\_ARROW

## Remarks

- This system variable is Read-Only.
- This system variable is designed for checking keystrokes from the **InputKey** command and setting keyboard macros with the **LoadKyBdMacro** command.

## See Also

**InputKey** and **LoadKyBdMacro** commands

---

## KEY\_UP\_ARROW

### Description

This system variable contains the [Up Arrow] key.

### Type/Size

Key

### Syntax

@KEY\_UP\_ARROW

### Remarks

- This system variable is Read-Only.
- This system variable is designed for checking keystrokes from the **InputKey** command and setting keyboard macros with the **LoadKyBdMacro** command.

### See Also

**InputKey** and **LoadKyBdMacro** commands

## LANG\_ID

### Description

This system variable is an array that contains the ID numbers of all defined languages.

### Type/Size

N9

### Syntax

@LANG\_ID

### Remarks

- This system variable is Read-Only.
- This system variable is only available on SAR Ops.

## LANG\_NAME

### Description

This system variable is an array that contains the language names for all defined languages. The indexing is the same as @lang\_id, therefore @lang\_name[1] is the name of the language associated with @lang\_id[1].

### Type/Size

A20

### Syntax

@LANG\_NAME

---

## Remarks

- This system variable is Read-Only.
- This system variable is only available on SAR Ops.

## LASTCKNUM

### Description

This system variable contains the previous check number that was assigned to the current guest check.

### Type/Size

N9

### Syntax

@LASTCKNUM

## Remarks

- This system variable is Read-Only.
- A last check number value of 0 indicates that the check number has not changed.

## LINE

### Description

This system variable contains the number of the current line in the script that is being executed.

### Type/Size

N5

### Syntax

@LINE

## Remarks

- This system variable is Read-Only.
- Use this system variable as a debugging tool.

## See Also

@LINE\_EXECUTED system variable

## LINE\_EXECUTED

### Description

This system variable contains the number of lines executed since the script began running.

### Type/Size

N5

---

## Syntax

@LINE\_EXECUTED

## Remarks

- This system variable is Read-Only.
- Use this system variable as a debugging tool.

## See Also

@LINE system variable

## MAGSTATUS

### Description

This system variable contains the Magnetic Card Entry Status Flag. The flag indicates whether data was input by swiping a card through a magnetic card reader.

### Type/Size

A1

## Syntax

@MAGSTATUS

## Remarks

- This system variable is Read-Only.
- The Magnetic Card Entry Status Flag will be either of the following settings:

**Table 23 Magnetic Card Entry Status Flag**

Flag	Description
Y	Indicates that data was input by swiping a card through a magnetic card
N	Indicates that data was input by means other than a magnetic card reader, such as via keyboard entry

- @MAGSTATUS is best used after issuing an **Input** or **WindowInput/Edit** command.

## Example

This event captures credit card information, entered manually from a keyboard or electronically from a magnetic card reader. The script uses the @MAGSTATUS system variable to determine the source from which the information is captured.

```
event : 1
  var cardholder_name : a20
  var account_num : a19
  var expire_date : n4
  var track1_data : a79
  var track2_data : a79
```

```

window 3, 78
touchscreen 16
displayMSinput 1, 2, cardholder_name{m2, 2, 1, *}, \
    "Read Credit Card or Enter Guest Name", \
    2, 2, account_num{m2, 1, 1, *}, "Enter Account Number", \
    3, 2, expire_date{m2, 3, 1, 4}, "Enter Expiration Date (YMMM)", \
    0, 0, track1_data{m1, *}, " "
windowinput
waitforclear
window 4, 40
display 1, 2, "Cardholder: ", cardholder_name

if @MAGSTATUS = "Y"
    display 2, 2, "As read from credit card."
else
    display 2, 2, "As entered from keyboard."
endif
waitforclear
endevent

```

## See Also

DisplayMSInput command

## MAXDTLR

### Description

This system variable contains the maximum size string required to format the transaction detail held in the @TRDTLR system variable.

### Type/Size

N9

### Syntax

@MAXDTLR

### Remarks

This system variable is Read-Only.

### See Also

@DTL\_\*, @MAXDTLT, and @TRDTLR system variables

## MAXDTLT

### Description

This system variable contains the maximum size string required to format the transaction detail held in the @TRDTLT system variable.

### Type/Size

N9

---

**Syntax**

@MAXDTLT

**Remarks**

This system variable is Read-Only.

**See Also**

@DTL\_\*, @MAXDTLR and @TRDTLT system variables

**MAXKYBDMACRO****Description**

This system variable contains the maximum number of macro keys that can be queued for the LoadKybdMacro command.

**Type/Size**

N9

**Syntax**

@MAXKYBDMACRO

**Remarks**

- This system variable is Read-Only.

**MAX\_LINES\_TO\_RUN****Description**

This system variable is a debugging tool that can be set to the maximum number of lines in the script to run.

**Type/Size**

N5

**Syntax**

@MAX\_LINES\_TO\_RUN = # of lines

**Remarks**

- This system variable has Read-Write attributes.
- This system variable should be set before the lines in the script that are being debugged.

**MINUTE****Description**

This system variable contains the current minute of the current hour.

**Type/Size**

N2

---

### Syntax

@MINUTE

### Remarks

- This system variable is Read-Only.
- A value returned will be from 0 to 59.

## MONTH

### Description

This system variable contains the current month of the current year.

### Type/Size

N2

### Syntax

@MONTH

### Remarks

- This system variable is Read-Only.
- The value returned will be from 1 to 12.

### Example

See the example for @DAY on page 7-27.

### See Also

@DAY and @YEAR system variables

## NEXTMYOPENCHECKGUID

### Description

This system variable contains the the guid of the oldest open check for this workstation.

### Type/Size

A

### Syntax

@NEXTMYOPENCHECKGUID

### Remarks

- This system variable is Read-Only.

## NUL

### Description

This system variable specifies that a binary 0 should be sent when printing binary data to a printer. The @nul variable is useful only on the *PrintLine* command.

---

**Type/Size**

A2

**Syntax**

@NEXTMYOPENCHECKGUID

**Remarks**

This system variable is used to escape the NUL character.

**NULL****Description**

This system variable contains a null object reference.

**Type/Size**

object

**Syntax**

@NULL

**Remarks**

- This system variable is Read-Only.
- There is no literal way to represent 'null' in SIM; this provides that capability.

**NUMDSC****Description**

This system variable contains the number of active discounts posted to the current guest check.

**Type/Size**

N1

**Syntax**

@NUMDSC

**Remarks**

This system variable is Read-Only.

**NUMDTLR****Description**

This system variable contains the number of transaction detail entries posted during the current service round on the guest check.

**Type/Size**

N5

---

**Syntax**

@NUMDTLR

**Remarks**

This system variable is Read-Only.

**NUMDTLT****Description**

This system variable contains the number of transaction detail entries posted to the current guest check.

**Type/Size**

N5

**Syntax**

@NUMDTLT

**Remarks**

- This system variable is Read-Only.
- This system variable is used to provide the maximum array limit for the @DTL\_\* system variables.

**Example**

See the example for @DTL\_MLVL on page 7-37.

**See Also**

@DTL\_\* and @NUMDTLR system variables

**NUMLANGS****Description**

This system variable holds the number of languages in the @lang\_id and @lang\_name arrays.

**Type/Size**

N9

**Syntax**

@NUMLANGS

**Remarks**

- This system variable is Read-Only.
- This system variable is only available on SAR Ops.

---

## NUMOPENCHK

### Description

This system variable contains the number

### Type/Size

object

### Syntax

@NUMOPENCHK

### Remarks

- This system variable is Read-Only.
- There is no literal way to represent 'null' in SIM; this provides that capability.

## NUMSI

### Description

This system variable contains the number of active sales itemizers defined in the RVC Descriptors module.

### Type/Size

N9

### Syntax

@NUMSI

### Remarks

This system variable is Read-Only.

## NUMSVC

### Description

This system variable contains the number of active service charge itemizers defined for the revenue center.

### Type/Size

N1

### Syntax

@NUMSVC

### Remarks

- This system variable is Read-Only.
- This system variable always returns the value of 1.

---

## NUMTAX

### Description

This system variable contains the number of active tax rates.

### Type/Size

N1

### Syntax

@NUMTAX

### Remarks

This system variable is Read-Only.

## OBJ

### Description

This system variable is the object number of the detail item for the event.

### Type/Size

N9

### Syntax

@OBJ

### Remarks

This system variable is only valid in the MI\*, DSC\*, SVC\*, and TNDR\* events.

## OFFLINE LINK

### Description

This system variable is used to link to an offline PMS system. For example, when the PMS is down, Ops can query the local guest database for account information and post the transaction offline.

### Type/Size

N12

### Syntax

@OFFLINE LINK

## OPNCHK\_CKNUM

### Description

This system variable contains the Open Check check number

### Type/Size

N5

---

### Syntax

@OPNCHK\_CKNUM[expression]

### Remarks

- The @NUMOPENCHK system variable must be called first to return data using any of the available @OPNCHK\_\* system variables.
- This system variable is Read-Only.
- The array limits of the expression are from 1 to the count return from @NUMOPENCHK.

## OPNCHK\_TREMPID

### Description

This system variable contains the Open Check transaction employee database ID

### Type/Size

N

### Syntax

@OPNCHK\_TREMPID[expression]

### Remarks

- The @NUMOPENCHK system variable must be called first to return data using any of the available @OPNCHK\_\* system variables.
- This system variable is Read-Only.
- The array limits of the expression are from 1 to the count return from @NUMOPENCHK.

## OPNCHK\_TREMPNUM

### Description

This system variable contains the Open Check transaction employee number

### Type/Size

N9

### Syntax

@OPNCHK\_TREMPNUM [expression]

### Remarks

- The @NUMOPENCHK system variable must be called first to return data using any of the available @OPNCHK\_\* system variables.
- This system variable is Read-Only.
- The array limits of the expression are from 1 to the count return from @NUMOPENCHK.

---

## OPNCHK\_WSID

### Description

This system variable contains the Open Check owner workstation database ID.

### Type/Size

N

### Syntax

@OPNCHK\_WSID [expression]

### Remarks

- The @NUMOPENCHK system variable must be called first to return data using any of the available @OPNCHK\_\* system variables.
- This system variable is Read-Only.
- The array limits of the expression are from 1 to the count return from @NUMOPENCHK.

## OPNCHK\_WSNUM

### Description

This system variable contains the Open Check owner workstation number.

### Type/Size

N

### Syntax

@OPNCHK\_WSNUM[expression]

### Remarks

- The @NUMOPENCHK system variable must be called first to return data using any of the available @OPNCHK\_\* system variables.
- This system variable is Read-Only.
- The array limits of the expression are from 1 to the count return from @NUMOPENCHK.

## OPSCONTEXT

### Description

This system variable contains the reference for the extensibility OpsContext object.

### Type/Size

object

### Syntax

@OPSCONTEXT

---

### Remarks

- This system variable is Read-Only.
- Consult extensibility documentation for methods and properties on this object.

## ORDERTYPE

### Description

This system variable contains the active order type on the current guest check.

### Type/Size

N9

### Syntax

@ORDERTYPE

### Remarks

This system variable is Read-Only.

## OrderType\_Name

### Description

This system variable contains the order type name for the current check.

### Type/Size

A

### Syntax

@OrderType\_Name

### Remarks

- This system variable is Read-Only.

## ORDR

### Description

This system variable is an array containing the object number of a Remote Order or Local Backup Printer defined for Symphony.

### Type/Size

N9

### Syntax

@ORDR[expression]

### Remarks

- This system variable is Read-Only.
- The array limits for the expression are from 1 to 15.
- This system variable can be used as an argument to the **StartPrint** command.

---

## Example

The example below starts a print job at a remote order printer.

```
sub print_message
  startprint @ordr1
    printline "======"
    printline "Message from ", sender_name
    printline "======"
  for rowcnt = 1 to 136
    if len(kitchen_msg[rowcnt]) > ""
      printline kitchen_msg[rowcnt]
    endif
  endfor
  printline "=====  
END MESSAGE  
======"
endprint
endsu
```

## See Also

- **StartPrint** command
- "ISL Printing"

## OS\_PLATFORM

### Description

This system variable is the value of the operating system platform:

**Table 24 Values Corresponding to the Operating System Platform**

Value	Description
1	Microsoft Windows CE
3	Microsoft Windows 32-bit

### Type/Size

N1

### Syntax

@OS\_PLATFORM

### Remarks

This system variable is Read-Only.

## PICKUPLOAN

### Description

This system variable is the value of the pickup or loan amount.

### Type/Size

\$4

### Syntax

@PICKUPLOAN

---

## Remarks

This system variable is only valid in the PICKUP\_LOAN event.

## PLATFORM

### Description

This system variable contains a character string identifying the hardware platform on which the script is running.

### Type/Size

A4

### Syntax

@PLATFORM

### Remarks

- This system variable is Read-Only.
- The string returned is "Symphony."

## PMSBUFFER

### Description

This system variable contains a string that points to the entire message received from the third-party system communicating with Symphony.

### Type/Size

String: size depends on the data returned from the third-party system (for example, PMS)

### Syntax

@PMSBUFFER

### Remarks

- This system variable has Read-Write attributes.
- The size of data in the PMS buffer is formatted as a string, which can be up to 32,768 bytes in length.
- This system variable is a debugging tool. For example, if the PMS message received by Symphony is suspected of being formatted incorrectly, using @PMSBUFFER the message can be displayed in an ISL-defined window as it is being received.
- Issuing @PMSBUFFER is valid only after a message has been received from the third-party system (for example, PMS).

## PMSLINK

### Description

This system variable contains the PMS Link defined in the *RVC Parameters* module.

---

### Type/Size

N2

### Syntax

@PMSLINK

### Remarks

- This system variable is Read-Only.
- The value returned by @PMSLINK will be the PMS defined in the *RVC Parameters* module to which the script is linked. For example, if @PMSLINK is executed by pms1.isl, which is linked to PMS Link #2 "1 Fidelio," then @PMSLINK will be set to "2."

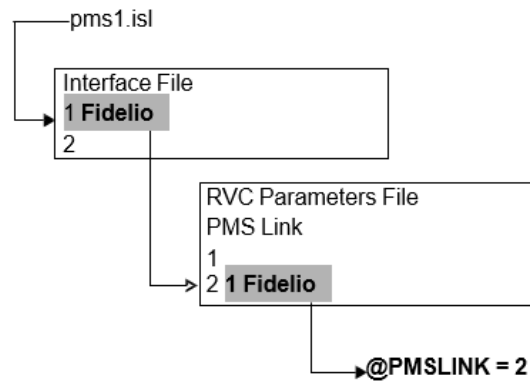

Figure 4 Example PMSLINK

### See Also

@PMSNUMBER system variable

## PMSNUMBER

### Description

This system variable contains the PMS object number, defined in the *Interfaces* module, to which the script is linked.

### Type/Size

N3

### Syntax

@PMSNUMBER

### Remarks

- This system variable has Read-Write attributes.
- To link the script file to a PMS, this object number is contained in the name of the script file. Thus, if running the script pms1.isl, then @PMSNUMBER will be set to 1.

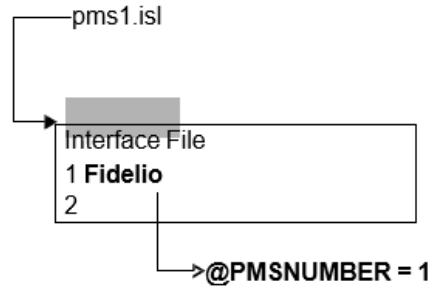

**Figure 5 Example PMSNUMBER**

**See Also**

@PMSLINK system variable

**PREVPAY**

**Description**

This system variable contains the total amount tendered thus far on the current guest check.

**Type/Size**

\$12

**Syntax**

@PREVPAY

**Remarks**

This system variable is Read-Only.

**PRINTSTATUS**

**Description**

This system variable sets the Print Status Flag to indicate whether a print job has completed successfully or failed.

**Type/Size**

A1

**Syntax**

@PRINTSTATUS

**Remarks**

- This system variable is Read-Only.
- The Print Status Flag will be either of the following settings:

**Table 25 Print Status Flags**

Flag	Description
Y	indicates that a print job completed successfully

---

Flag	Description
N	indicates that a print job failed

### Example

The event procedure below uses the setting of @PRINTSTATUS to determine which message to display after issuing the **Printline** command.

```

event inq : 1
  startprint @chk
    printline "this is a line"
  endprint
if @printstatus = "Y"
  waitforclear "Print successful"
else
  waitforclear "Print failed"
endif

```

### See Also

- **Printline** command
- "ISL Printing"

## PROPERTY

### Description

This system variable returns the Property Number of the Workstation.

### Type/Size

N9

### Syntax

@PROPERTY

### Remarks

This system variable is Read-Only.

## QTY

### Description

This system variable is the quantity of the detail item for the event.

### Type/Size

N9

### Syntax

@QTY

### Remarks

This system variable is only valid in the MI\*, DSC\*, SVC\*, and TNDR\* events.

---

## RANDOM

### Description

This system variable returns a random value between 0 and 232-1.

### Type/Size

N9

### Syntax

@RANDOM

## RCPT

### Description

This system variable contains the object number of the Customer Receipt Printer defined for the System Unit.

### Type/Size

N9

### Syntax

@RCPT

### Remarks

- This system variable is Read-Only.
- This system variable can be used as an argument to the **StartPrint** command.

### See Also

- StartPrint command
- "ISL Printing"

## REDOFF

### Description

This system variable contains printed text to black ink (or default ink, such as blue).

### Type/Size

A1

### Syntax

@REDOFF

### Remarks

- This system variable is Read-Only.
- @REDOFF is also known as a print directive and can be an argument of the **Printline** command.
- All new lines of text print default ink (for example, black or blue).

---

**Note:** The Citizen autocut roll printer does not recognize the first occurrence of this variable after a printline command. The second occurrence, and all succeeded occurrences of this variable, are recognized by the Citizen autocut roll printer.

This situation does NOT occur with standard roll printers.

---

### Example

The ISL statement below prints "Print line" in double-wide characters and red ink, then turns off these print directives.

```
startprint printer
  printline          "-----"
  printline @dwon, @redon,          "chit"
  printline          "-----"
  @dwoff, @redoff
endprint
```

### See Also

- @REDON system variable; **Printline** command
- "ISL Printing"

## REDON

### Description

This system variable prints the expression that follows it in red ink.

### Type/Size

A1

### Syntax

@REDON

### Remarks

- This system variable is Read-Only.
  - @REDON is also known as a print directive and can be an argument of the **Printline** command.
  - Characters in red and black ink can print on the same line.
- 

**Note:** The Citizen autocut roll printer does not recognize the first occurrence of this variable after a printline command. The second occurrence, and all succeeded occurrences of this variable, are recognized by the Citizen autocut roll printer.

This situation does NOT occur with standard roll printers.

---

### Example

The ISL statement below will print "Print line" in double-wide characters and red ink.

```
Printline @dwon, @redon, "Print line"          //prints double-wide in red
```

### See Also

- @REDOFF system variable; **Printline** command

- 
- “ISL Printing”

## RETURNSTATUS

### Description

This system variable is set to “Y” when the Return and Transaction Return functions are active; otherwise, the variable is set to “N.”

### Type/Size

A1

### Syntax

@RETURNSTATUS

### Remarks

This system variable is Read-Only.

## RUNNINGDIRECTORY

### Description

This system variable contains the absolute path for the current executable.

### Type/Size

A

### Syntax

@RUNNINGDIRECTORY

### Remarks

- This system variable is Read-Only.

## RVC

### Description

This system variable contains the number of the revenue center to which the script is linked by its revenue center PMS link.

### Type/Size

N3

### Syntax

@RVC

### Remarks

- This system variable is Read-Only.
- This system variable will be set to the object number of the revenue center in which the script is running. For instance, if the PMS link for pms1.isl is defined in revenue center #4, then the system variable will be set to 4.

---

## RVC\_NAME

### Description

This system variable contains the current revenue center's name.

### Type/Size

A16

### Syntax

@RVC\_NAME

### Remarks

This system variable is Read-Only.

## RXMSG

### Description

This system variable contains the Event ID assigned to the response message sent by a third-party system to Symphony.

### Type/Size

A32

### Syntax

@RXMSG

### Remarks

- This system variable is Read-Only.
- This command is not available on SAR Ops.
- When either the **WaitForRxMsg** or **GetRxMsg** commands are executed, the ISL waits for a return event. The first field of the *Application\_Data* segment of the response message is assumed to be the Event ID of the return event. The @RXMSG system variable contains that Event ID.

### Example

In the event below, the @RXMSG system variable is used to verify that the Event ID in the returned message is the correct one.

```
event inq : 1
  txmsg "ver_req"                // Transmit string requesting
                                //   version of system software
  getrxmsg                       // Wait for response

  if @rxmsg = "ver_rsp"
    rxmsg version_s              // Format message received
    waitforclear version_s      // Display it
  elseif @rxmsg = "ver_err"
    errormessage "Version number invalid"
    exitcancel
  endif
endevent
```

---

**See Also**

- GetRxMsg and WaitForRxMsg commands
- [Application\\_Data](#)

**SEAT****Description**

This system variable contains the number of the active seat on the current guest check.

**Type/Size**

N5

**Syntax**

@SEAT

**Remarks**

This system variable is Read-Only.

**SECOND****Description**

This system variable contains the current second of the current minute.

**Type/Size**

N2

**Syntax**

@SECOND

**Remarks**

- This system variable is Read-Only.
- A value from 0 to 59 is valid.

**See Also**

@MINUTE system variable

**SI****Description**

This system variable is an array containing the sales itemizer totals posted to the current guest check.

**Type/Size**

\$12

**Syntax**

@SI[*expression*]

---

## Remarks

- This system variable is Read-Only.
- The array limits of the *expression* are from 1 to 16.
- This system variable will return the totals posted to the sales itemizer specified by the array index. For example, if the array index references @SI[1], any totals posted to Sales Itemizer #1 will be returned.

## SI\_DSC

### Description

This system variable contains the discount sales itemizer

### Type/Size

\$

### Syntax

@SI\_DSC[expression]

### Remarks

This system variable is Read-Only.

## SIMDBLINK

### Description

This system variable links to the SIMDB DLL to the database. For example, if a property has a PMS System which has two connections—one for live postings and another for room updates to the SIMDB DLL—the two systems can be linked with the @SIMBLINK system variable in SIM

### Type/Size

N12

### Syntax

@SIMDBLINK

## SRVPRD

### Description

This system variable contains the active serving period.

### Type/Size

N9

### Syntax

@SRVPRD

### Remarks

This system variable is Read-Only.

---

## STACKFRAMETEXT

### Description

This system variable contains the stack frame of the SIM engine for the line being executed.

### Type/Size

A

### Syntax

@STACKFRAMETEXT

### Remarks

- This system variable is Read-Only.
- This is not a .net stack trace but a SIM subroutine stack.

## STRINGARGS

### Description

This system variable contains the status for directing how SIM processes list input.

### Type/Size

N

### Syntax

@STRINGARGS

### Remarks

- This system variable is Read/Write
- When processing list input (parsing a variable list of values) the SIM engine can be directed what to do with a mismatch between expected number of items versus actual number of items.
- If set to 0 SIM will not throw an error if the expected versus actual number of items differ.
- If set to 1 SIM will throw an error when the number of values differ.

## SVC

### Description

This system variable contains the total amount of service charges posted to the current guest check.

### Type/Size

\$12

### Syntax

@SVC

---

## Remarks

- This system variable is Read-Only.
- The @CHGTIP amount is included in the @SVC system variable.

## SVCI

### Description

This system variable is an array that contains the service charge itemizer totals posted to the current guest check.

### Type/Size

\$12

### Syntax

@SVCI[*expression*]

### Remarks

- This system variable is Read-Only.
- The array limits of the *expression* are from 1 to 16.
- This variable will return totals posted to the service charge itemizer specified by the array index.
- This variable is similar to the @SI variable.

## SYSLOGTRACE

### Description

This system variable contains the status for directing how SIM logs execution lines.

### Type/Size

N

### Syntax

@SYSLOGTRACE

### Remarks

- This system variable is Read/Write
- When set to 1 each SIM text line will be logged to the EGateway log until either the script ends or this variable is set to 0.
- This variable can be used to troubleshoot scripts.

## SYSTEM\_STATUS

### Description

This system variable contains the shell return status after the **System** command is executed.

---

**Type/Size**

N6

**Syntax**

@SYSTEM\_STATUS

**Remarks**

This system variable is Read-Only.

**TAX****Description**

This system variable is an array containing the totals posted to the active tax rate on the current guest check.

**Type/Size**

\$12

**Syntax**

@TAX[*expression*]

**Remarks**

- This system variable is Read-Only.
- The array limits for the *expression* are from 1 to 8.

**See Also**

@TAXRATE[] system variable

**TAXRATE****Description**

This system variable is an array containing the tax rate defined for the specified Taxes module.

**Type/Size**

A6

**Syntax**

@TAXRATE[*expression*]

**Remarks**

- This system variable is Read-Only.
- The array limits for the *expression* are from 1 to 8.
- The value returned is a string instead of an amount, since the percentage may be any number of decimal digits (for example, 5.1265).

**See Also**

@TAX[] system variable

---

## TAXVAT

### Description

This system variable returns the Value Added Tax amount for Tax Rate “X”.

### Type/Size

\$12

### Syntax

@TAXVAT[*expression*]

### Remarks

This system variable is Read-Only.

### See Also

@TAX[] system variable

## TBLID

### Description

This system variable contains the sequence number of the table ID assigned to the current guest check.

### Type/Size

A4

### Syntax

@TBLID

### Remarks

This system variable is Read-Only.

### See Also

@TBLNUM system variable

## TBLNUM

### Description

This system variable contains the sequence number of the table ID assigned to the current guest check.

### Type/Size

N9

### Syntax

@TBLNUM

### Remarks

This system variable is Read-Only.

---

## Example

This event is used to send to the PMS a message indicating which table has just paid its check.

```
event final_tender

    txmsg "CHECK_PAID", @cknum, @tblnum

    // Here we do a 'getrxmsg' to receive the message to fulfill the
    // requirements of the protocol, but do not process any data
    // associated with the message.

    getrxmsg

endevent
```

## TICKCOUNT

### Description

This system variable contains the tick count for the executing application.

### Type/Size

N

### Syntax

@TICKCOUNT

### Remarks

- This system variable is Read-Only.
- This variable returns the value of the .net framework System.Environment.TickCount property.

## TMDNUM

### Description

This system variable contains the number assigned to the tender/media associated with this posting.

### Type/Size

N9

### Syntax

@TMDNUM

### Remarks

This system variable is Read-Only.

## TNDTTL

### Description

This system variable contains the total for this posting, which can be reduced.

---

### Type/Size

\$12

### Syntax

@TNDTTL

### Remarks

- This system variable has Read-Write attributes.
- This system variable must be accessed within a tender/media event.
- The purpose of this system variable is to allow the total due on a check to be updated if necessary. This system variable is best used in an environment where some form of credit limit is applied to purchases, such as in a student meal plan or a frequent diner program for hotel patrons. In a student meal plan, students may have a set amount of credit applied to each meal. For example, assume that each student meal credit limit is \$4.50 per meal. If a student surpasses this amount with a purchase of \$6.00, the @TNDTTL (\$6.00) can be overwritten with the credit limit of \$4.50. Then the student can cover the difference of \$1.50 with cash, for example.

### Example

In the example that follows, the tender total is reduced from \$6.00 to \$4.50, the allowable student meal credit.

```
event tmed : 1
    txmsg "POST", @tndttl           // send over $6.00
    waitforrxmsg
endevent

event rxmsg: POST
    var new_tndttl : $10
    rxmsg new_tndttl               // receive $4.50
    if new_tndttl > 0
        @tndttl = new_tndttl
        exitcontinue
    else
        exitcancel                 // cancel
endevent
```

## TOTALMEMORY

### Description

This system variable holds the amount of total memory available as reported by the .net framework.

### Type/Size

N

### Syntax

@TOTALMEMORY

### Remarks

- This system variable is Read-Only.

- 
- This variable is a passthrough to @OpsContext.TotalMemory

## TRACE

### Description

This system variable must be set to a non-zero value in order to output each executed ISL statement to the 8700d.log file.

### Type/Size

N5

### Syntax

@TRACE = *integer*

### Remarks

- This system variable has Read-Write attributes.
- The primary usage of this feature is debugging.

## TRAILER

### Description

This system variable is string array with 32 elements. The @TRAILER[] array is unique to each event. This means that each event can begin writing to the array starting at index 1, rather than at the next available index.

### Type/Size

A32

### Syntax

@TRAILER[*expression*]

### Remarks

- This system variable is Read-Write.
- This system variable is only used with the **Print\_Header** event. All transaction system variables are still valid in this event. User input is still allowed, as are file operations and display manipulation. See page [8-37](#).

### See Also

**Print\_Header** and **Print\_Trailer** events and @HEADER system variable.

## TRAININGMODE

### Description

This system variable contains the Training Mode Status of an employee.

### Type/Size

N1

---

## Syntax

@TRAININGMODE

## Remarks

- This system variable is Read-Only.
- The Training Mode Status will be either of the following settings:

**Table 26 Training Mode Status**

Status	Description
Zero	indicates that the employee is not in training mode
Non-zero	indicates that the employee is in training mode

## TRCSHR

### Description

This system variable contains the Transaction Cashier number of the current guest check.

### Type/Size

N9

### Syntax

@TRCSHR

### Remarks

This system variable is Read-Only.

## TRDTLR

### Description

This system variable contains transaction detail posted to the current guest check during this service round.

### Type/Size

Various (see Remarks)

### Syntax

@TRDTLR

### Remarks

- This system variable is Read-Only.
- The transaction detail information is designed to provide enough detail, to display or print a basic guest check. If more information is required, it should be exported from the appropriate database files with the Symphony SQL module.
- Each transaction detail entry comprises the following fields:

**Table 27 Transaction Detail Fields**

Field	Type and Size	Description
Detail Type	A1	Indicates type of detail entry: I = Check Information Detail M = Menu Item D = Discount S = Service Charge T = Tender/Media R = Reference Number
Status	A6	Check Detail Status Flag
Number	N9	Object number; set to 0 for reference numbers and check information detail.
Quantity	N5	Quantity; set to 0 for reference numbers and check information detail.
Main Sales Level	N1	Main sales level (between 1 and 8); set to 0 for reference numbers and check information detail.
Sub Sales Level	N1	Sub sales level (between 1 and 8); set to 0 for reference numbers and check information detail.
Total	\$12	Total; set to 0 for reference numbers and check information detail.
Name	A22	Contains the detail's name (menu item, discount, etc.). For reference numbers, this contains the actual reference number.

- The transaction detail is preceded by the **Number of Detail Entries** field. This field is of the type and size N3 and indicates how many detail entries follow.
- When partial payments are posted to a PMS using prorated itemizers, all the detail on the guest check will be transferred, not just the detail associated with this partial payment. If selective detail is required, the guest check should be split at the POS prior to being posted to the PMS.

**See Also**

@DTL\_\*, @MAXDTLR, and @TRDTLT system variables

**TRDTLT****Description**

This system variable contains all the transaction detail from the current guest check.

**Type/Size**

Various (see Remarks)

---

## Syntax

@TRDTLT

## Remarks

- This system variable is Read-Only.
- The transaction detail information is designed to provide enough detail, to display or print a basic guest check. If more information is required, it should be exported from the appropriate database files with the Symphony SQL module.
- Each transaction detail entry comprises the fields described in the Table 27 Transaction Detail Fields.
- The transaction detail will be preceded by the **Number of Detail Entries** field. This field is of the type and size N3 and indicates how many detail entries follow.
- When partial payments are posted to a PMS using prorated itemizers, all the detail on the guest check will be transferred, not just the detail associated with this partial payment. If selective detail is required, the guest check should be split at the POS prior to being posted to the PMS.

## See Also

@MAXDTLT and @TRDTLR system variables

## TREMP

### Description

This system variable contains the number of the Transaction Employee, the employee posting sales to the current guest check.

### Type/Size

N9

## Syntax

@TREMP

## Remarks

- This system variable is Read-Only.
- Typically, the Transaction Employee is also the Check Employee, or the person who originally began the check. However, managers and cashiers may be privileged to be the Transaction Employee if they must post sales to another employee's check. Depending on the revenue center options enabled, sales totals and tender totals will post to either the Check Employee or the Transaction Employee and to their corresponding Cashier Totals, if there is a link.

## See Also

@CKEMP system variable

---

## TREMP\_CHKNAME

### Description

This system variable contains the Transaction Employee's check name, the employee posting sales to the current guest check.

### Type/Size

A16

### Syntax

@TREMP\_CHKNAME

### Remarks

This system variable is Read-Only.

## TREMP\_FNAME

### Description

This system variable contains the Transaction Employee's first name, the employee posting sales to the current guest check.

### Type/Size

A8

### Syntax

@TREMP\_FNAME

### Remarks

This system variable is Read-Only.

## TREMP\_LNAME

### Description

This system variable contains the Transaction Employee's last name, the employee posting sales to the current guest check.

### Type/Size

A16

### Syntax

@TREMP\_LNAME

### Remarks

This system variable is Read-Only.

---

## TREMP\_TYPEDEF

### Description

This system variable is an array that contains the employee option bits for the transaction employee.

### Type/Size

N1, array

### Syntax

@TREMP\_TYPEDEF

### Remarks

This system variable is Read-Only.

## TTL

### Description

This system variable is the amount of the detail item for the event.

### Type/Size

\$12

### Syntax

@TTL

### Remarks

This system variable is only valid in the MI\*, DSC\*, SVC\*, and TNDR\* events.

## TTLDUE

### Description

This system variable contains the total due for the current guest check.

### Type/Size

\$12

### Syntax

@TTLDUE

### Remarks

This system variable is Read-Only.

## TXBL

### Description

This system variable is an array containing the taxable sales itemizer on the current guest check.

---

**Type/Size**

\$12

**Syntax**

@TXBL[*expression*]

**Remarks**

- This system variable is Read-Only.
- The array limits of the *expression* are from 1 to 8.

**TXEX\_ACTIVE****Description**

This system variable checks if the Tax is exempt at the specified level.

**Type/Size**

N1

**Syntax**

@TXEX\_ACTIVE[*expression*]

**Remarks**

This system variable is Read-Only.

**USEDMEMORY****Description**

This system variable holds the amount of total memory used as reported by the .net framework.

**Type/Size**

N

**Syntax**

@TOTALMEMORY

**Remarks**

- This system variable is Read-Only.
- This variable is a passthrough to @OpsContext.UsedMemory

**USERENTRY****Description**

This system variable contains the data entered by an operator prior to pressing the SIM Inquiry key.

**Type/Size**

A20

---

## Syntax

@USERENTRY

## Remarks

- This system variable is Read-Only.
- @USERENTRY will contain the data entered prior to pressing the SIM Inquiry key. For example, if an operator enters "123" then presses the SIM Inquiry key, @USERENTRY will contain "123."

## VALD

### Description

This system variable contains the object number of the Validation Chit Printer assigned to the workstation.

### Type/Size

N9

## Syntax

@VALD

## Remarks

- This system variable is Read-Only.
- This system variable can be used as an argument to the **StartPrint** command.

## See Also

- **StartPrint** command
- "ISL Printing"

## VARIABLEFRAMETEXT

### Description

This system variable holds a string which lists all the declared user variables in all stack frames.

### Type/Size

A

## Syntax

@VARIABLEFRAMETEXT

## Remarks

This system variable is Read-Only.

## VERSION

### Description

This system variable contains the version designation of the SIM.

---

### Type/Size

Various (see Remarks)

### Syntax

@VERSION

### Remarks

- This system variable is Read-Only.
- This system variable returns text of varying lengths.

### Example

The event below draws a window and displays the SIM version number.

```
event inq : 1
  window 1, 30
  display 1, @center, "The SIM Ver is: ", @version
endevent
```

## VOIDSTATUS

### Description

This system variable is set to "Y" when the Void and Transaction Void functions are active; otherwise, the variable is set to "N."

### Type/Size

A1

### Syntax

@VOIDSTATUS

### Remarks

This system variable is Read-Only.

## WARNINGS\_ARE\_FATAL

### Description

This system variable interrupts script processing with a fatal error if variable overflow occurs.

### Type/Size

N5

### Syntax

@WARNINGS\_ARE\_FATAL

### Remarks

- This system variable has Read-Write attributes.
- By default, no error is reported when strings, reals, or integers overflow the variables to which they are assigned; the values are truncated to fit the variables. The @WARNINGS\_ARE\_FATAL system variable can be set to handle the

---

instance when the script writer wants the ISL to report a fatal error if a variable overflow occurs. If @WARNINGS\_ARE\_FATAL is set equal to 1, variable overflow will cause a fatal error, thereby interrupting script processing.

- Specify @WARNINGS\_ARE\_FATAL at the top of the script.

### Example

```
@WARNINGS_ARE_FATAL = 1

event tmed : 9
  var room : a6
  var guest_name : a20

window 4, 22, "Room Charge"
.
.
.
```

## WCOLS

### Description

This system variable contains the number of columns in the ISL-defined window currently displayed.

### Type/Size

N9

### Syntax

@WCOLS

### Remarks

This system variable is Read-Only.

## WEEKDAY

### Description

This system variable contains the day of the week.

### Type/Size

N1

### Syntax

@WEEKDAY

### Remarks

- This system variable is Read-Only.
- Valid values range from 0 - 6, where 0 is Sunday.

---

## **WROWS**

### **Description**

This system variable contains the number of rows in the ISL-defined window currently displayed.

### **Type/Size**

N9

### **Syntax**

@WROWS

### **Remarks**

This system variable is Read-Only.

## **WSID**

### **Description**

This system variable contains the workstation ID number.

### **Type/Size**

N9

### **Syntax**

@WSID

### **Remarks**

This system variable is Read-Only.

## **WSNUM**

### **Description**

This system variable holds the current workstation object number

### **Type/Size**

N

### **Syntax**

@WSNUM

### **Remarks**

This system variable is Read-Only.

## **WSSUBTYPE**

### **Description**

This system variable holds the current workstation's configured sub type.

---

**Type/Size**

N

**Syntax**

@WSSUBTYPE

**Remarks**

This system variable is Read-Only.

**WSTYPE****Description**

This system variable is the User Workstation type, such as SAR client of mobile devices.

**Type/Size**

N9

**Syntax**

@WSTYPE

**Remarks**

- This system variable is Read-Only.
- The workstation types correspond to the type field in the workstation definition and are as follows:
  - 1 = Mobile
  - 2 = Workstation Client
  - 3 = POSAPI Client
  - 6 = Tablet Client
  - 7 = Castles Teh S1F2

**YEAR****Description**

This system variable is at least a two-digit number that contains the number of years since 1900.

**Type/Size**

N2 or N3. This will be a two-digit number up until the year 2000, when it becomes a three-digit number.

**Syntax**

@YEAR

**Remarks**

This system variable is Read-Only.

---

### **Example**

The year 1999 would be 99 (1999-1900), the year 2000 would be 100 (2000-1900), and the year 2025 would be 125 (2025-1900).

### **See Also**

@DAY and @MONTH system variables

## **YEARDAY**

### **Description**

This system variable contains the number representing the current day of the year.

### **Type/Size**

N3

### **Syntax**

@YEARDAY

### **Remarks**

- This system variable is Read-Only.
- A valid value is from 0 to 365.



---

---

## 8 ISL Commands

This chapter contains a summary and an A-Z reference of all ISL commands, as well as a discussion of format specifiers used in command syntax.

### Commands

The Interface Script Language (ISL) provides commands to display information, get operator entries, display touchscreens, execute keyboard macros, as well as transmit and receive messages over the interface. This chapter contains a detail description of each ISL command.

#### Command Summary

For quick reference, a summary of commands in alphabetical order and in order by category of function begins on page [8-1](#).

#### File I/O Operations

A brief introduction and discussion of file I/O commands and system variables is also included in this chapter. Before attempting any file, I/O operations for the first time, review this discussion and the detail descriptions of the applicable file I/O commands.

#### Format Specifiers

This language element can be part of the syntax of certain commands. Format specifiers can be used to change the format of both input and output data. Review [Using Format Specifiers](#) to learn the ways in which this language element can be used in command syntax.

### ISL File Input/Output Commands

The ISL interpreter includes commands for file operations like those offered by languages such as C and BASIC. Anyone familiar with these languages should be comfortable with the ISL file I/O commands.

All file processing involves the following three steps in the order listed:

1. Open the file
2. Perform all read and write operations
3. Close the file

#### The FOpen Command

When a file in ISL is opened using the FOpen command, it is assigned a file number between 1 and 10. While no other file commands can modify this value, this file number is required with all the ISL File Input/Output commands. Since this value is a normal ISL integer, it can be passed into subroutines. The file number's value, when the FOpen command is called, will be ignored.

---

Since ISL is intended to run in a multiprocessing environment, it also has commands for “locking files.” This means if a script must read a file, it has the capability to prevent other programs from changing the file while it is being read.

## File I/O System Variables

All file operations affect two system variables: @FILE\_ERRNO and @FILE\_ERRSTR. Programmers will recognize these two variables as corresponding to the C “errno” variable and the C “strerror( )” function. If an error has been detected, then @FILE\_ERRNO will be set to a non-zero value, and @FILE\_ERRSTR will be the readable string describing the condition.

ISL maintains a temporary internal buffer for reading and writing data to and from a file. This buffer is normally set at 2048 bytes. The size of this buffer is available in the system variable @FILE\_BFRSIZE.

If a script’s file operations require reading or writing data lines greater than 2K, then the script should change the size of the buffer by directly changing the value of @FILE\_BFRSIZE. The file buffer size applies to all files used in the script.

For example, if the script is reading lines from a file which is 4K in length, then it should execute the following line:

```
@FILE_BFRSIZE = 4096
```

## Input/Output File Format

In general, ISL file handling is geared for reading and writing ASCII files, specifically, comma-separated files (for example, the files exported and imported via the Symphony Data Access Service). In this format, integers and real values appear without quotes, and non-numeric values appear within quotes.

For example, an employee file may look like this:

```
134,"Tooher","Daniel",100.00,"12FE"  
156,"Collins","Michael",150.00,"12FF"  
179,"Blaine","Richard",125.00,"56BB"
```

ISL has commands for automatically breaking these comma-separated fields into variables and writing variables as comma-separated lines. If the format of each line is not a list of fields, then commands exist to read an individual line into a string, as well as writing an individual string to a file.

## Using Format Specifiers

In general, the default behavior for entering data and displaying data in ISL is sufficient for most needs. However, it is necessary sometimes to change the default behavior to suit the application at hand. For example, one might want to allow magnetic card data entry, to pad displayed data with 0s instead of spaces, or to center data within a display area.

A variety of ISL commands can be used to accomplish this type of formatting, using a language element called a format specifier. To know if the command takes a format specifier as an argument, look at the syntax for the command in the ISL Command Reference.

---

## What is a Format Specifier?

A format specifier is text enclosed in braces and appears directly after the variable or constant whose input/output behavior is affected. When defined, a format specifier changes the way that the variable or constant is input or output.

For example, the following command will display the contents of the user variable `guest_name` in the prompt area. The format specifier appears directly after the `guest_name` variable.

```
PROMPT guest_name{ 20" }
```

---

**Note:** The meaning of the data within the braces will be explained later.

---

## Types of Format Specifiers

There are two types of specifiers: input and output. Input specifiers are placed after input variables in commands that get data from a user: **Display**, **DisplayMSInput**, **Input**, and **InputKey**. Output specifiers are placed after variables and expressions that are being converted to ASCII for outputting data to the screen, printer, or a message to a PMS.

### Specifier Attributes

The general layout of a format specifier is:

```
{ [input_specifier] [output_specifier] }
```

- The *input\_specifier* and *output\_specifier* consists of individual specifiers, which are usually one character.
- Spaces and tabs may be used in a format specifier for clarity. The following two format specifiers are equivalent:

```
{ -=08 }  
{ - = 0 8 }
```

- Input and output specifiers can appear within one format specifier. However, not all individual specifiers may have a meaning. For example, it is possible to put input specifiers after a variable which is going to be displayed, but since data is not being entered into the variable, the input specifiers are meaningless and are ignored.

### Input Specifiers

The input specifiers only have meaning for commands which receive input from the user. They are ignored if they appear in commands which only output data (for example, the **Display** command).

All input specifiers **must** be placed before any output specifiers. If they are present, they must also be placed in the order listed in the following table:

**Table 28 Input Specifier Placement Order**

<b>Input Specifier</b>	<b>Description</b>
-	Data being typed in by the operator should not be echoed back to the display
<i>Mn</i>	Specify the track number ( <i>n</i> = 1 or 2) and what data to read from the magnetic card. For use with the <b>Input</b> , <b>InputKey</b> , <b>DisplayInput</b> , and <b>DisplayMSInput</b> commands only. The M character is case-insensitive

**Input Specifier**

The - specifier is used to hide data being entered by the operator. For example, authorization codes or passwords should not be echoed to the display as the operator types them in. The following command prompts the operator for an authorization code, but echoes it back to the display as it is being typed:

```
Input auth_code, "Enter authorization code"
```

It can be rewritten so that no data is echoed:

```
Input auth_code{-}, "Enter authorization code"
```

If the - specifier is used in commands which require both operator input and the data to be displayed, then not only is the data not echoed, but it is not displayed in the window after it is entered. Instead, the field contains asterisks where data is expected.

**M Input Specifier**

The M specifier is used when magnetic card data may be entered in lieu of the operator typing the data in. The M specifier defines whether the data is on a mag card, and which track and field the data should be read from. For example, it is possible to use the M specifier to get an authorization code from track 2, field 1, starting offset 3, and copy in 10 characters.

There are two M formats:

- Format 1 Syntax: *Mn*,\*
- Format 2 Syntax: *Mn*, field, start, count | \*

These fields are defined as follows:

**Table 29 M Input Specifier Format Fields**

<b>Field</b>	<b>Description</b>
<i>Mn</i> :	The track number (M1 or M2). This can be followed by a star (*) to specify all fields on the track or use the remaining fields in this table to read specific information.
<i>field</i> :	The field position within the specified track. This is a positive integer.
<i>start</i> :	The starting offset (character) within the field. For example, if the last four characters of the "Blaine Richard" string needed to be removed, start the offset at 11.

Field	Description
<i>count</i> :	Number of characters to be read from the <i>start</i> (first character) to the end of the <i>field</i> (place an asterisk * to include all characters).

### Format One

In format 1, the data from the entire track (1 or 2) will be placed into the variable when the mag card is swiped. The following command allows the user to enter a code or swipe a magnetic card:

```
Input auth_code{ M2,* }, "Enter authorization code"
```

If the mag card is swiped, then all the data from track 2 (M2) will be placed into the variable `auth_code`.

### Format Two

Format 2 defines exactly where the data in the track occurs. If the authorization code appears in field 1 of track 2, and furthermore, starts at character 3 in the field and consists of 10 characters, then the command can be rewritten as:

```
Input auth_code{ M2,1,3,10 }, "Enter authorization code"
```

If the operator swipes the card, the appropriate data will be extracted from the field and placed into `auth_code`.

---

**Note:** An \* can be substituted for count, to specify ALL data from the start offset in the field.

---

### Field Positions for Credit Cards

The following is an illustration of the standard field positions for credit cards:

#### Track 1:

**Table 30 Track 1 Field Positions of Credit Cards**

Field #	1	2	3
Data	16/19 Digit Account Number	26 Alpha Character	Y Y M M

#### Track 2:

**Table 31 Track 2 Field Positions of Credit Cards**

Field #	1	2
Data	16/19 Digit Account Number	Y Y M M

The following **Input** command allows the operator to enter the credit card name or swipe the card and have the name transferred from track 1, field 2.

```
Input card_name{ M1,2,1,* }, "Enter cardholder name"
```

The following is an illustration of the standard *field* position for the magnetic employee card (Note: this card is Track 2 only):

**Table 32 Standard Field Position for Magnetic Employee Card**

Field #	1
Data	10 Digit Employee Number

The following **Input** command will get the employee number from the operator or the mag card and will not echo the data as it is being entered:

```
Input empl_num{ - M2,1,1,10 }, "Enter employee number"
```

**Using Both Input Specifiers**

Both input specifiers may be used. This command uses both the - and the M specifiers:

```
Input auth_code{ - M2,1,3,10 }, "Enter authorization code"
```

**Output Specifiers**

Output specifiers are used after variables and expressions that are being converted to ASCII. The output specifiers are like the C language printf() specifiers. The following table lists some representative commands for each of these output types:

**Table 33 Commands for Output Types**

Commands	Output Type
Display, WaitForConfirm, and Window	Screen
PrintLine	Printing
FWrite	File I/O
TxMsg	PMS

**Syntax**

The proper syntax for using the output\_specifiers is as follows:

```
[<|=|>|*] [+ ] [0] [size] [D|X|O|B] [^] ["] [:format_string]
```

Output specifiers *must* also be placed in the order listed in the following table:

**Table 34 Output Specifier Placement Order**

Output Specifier	Description
<	Left justification; the <i>size</i> specifier may be used to specify the size of the field.
=	Center justification: the <i>size</i> specifier may be used to specify the size of the field.
>	Right justification: the <i>size</i> specifier may be used to specify the size of the field.
*	Trim leading and trailing spaces; the <i>size</i> specifier may be used to specify the size of the field.
+	Place the sign at the start of field.
0	Place the sign at the start of field.

Output Specifier	Description
<i>size</i>	Where <i>size</i> is the number of the characters in the required field. The <i>size</i> must be a positive integer or an expression that is a positive integer.
D	Decimal (Default); display numerics in decimal format.
X	Hexadecimal; display numerics in hexadecimal format.
O	Octal; display numerics in octal format.
B	Binary; display numerics in binary format.
^	Place a space on each side of the data to be displayed.
"	Place double quotes around the data to be displayed.
:format_string	Like the BASIC language PRINT USING command. All characters are displayed except for the # character, which will be replaced by characters from the variable or expression preceding the format specifier.

## Examples of Specifiers

The following are examples of how Input and Output Specifiers may be used. For complete examples and explanations of the ISL commands, see [ISL Command Reference](#).

### Input Specifier

The following lines would read data from a Credit Card:

```
displaymsinput 1, 2, cardholder_name{m1, 2, 1, *}, "Enter Guest Name", \
    2, 2, account_num{m1, 1, 1, *}, "Enter Account Number", \
    3, 2, expiration_date{m1, 3, 1, 4}, "Enter Expiration"
```

### Output Specifiers

#### Justification Specifiers

The justification specifiers <, =, and > are only meaningful when the size of the expression being formatted is greater than the size of the variable itself.

All integers and decimal expressions are right justified, and all string expressions are left justified, by default. The following section gives examples and shows how these specifiers can be used to justify data:

**Table 35 Examples for Justification Specifiers**

Expression	Output
125 { 8 }	125
125 { <8 }	125
125 { =8 }	125

Expression	Output
125 {>8 }	125
"abc" { 8 }	abc
"abc" { =8 }	abc

### \* Specifier

The \* specifier is used when the expression should be displayed with leading and trailing spaces removed.

**Table 36 Examples for \*Specifier**

Expression	Output
"125" {*}	125
" 125 " {*}	125
" word 1 and word 2 " {*}	word 1 and word 2

### + Specifier

The + specifier is used to override the default behavior of displaying negative numbers with the - sign to the right of the number by causing the - to appear on the left.

**Table 37 Examples for + Specifier**

Expression	Output
-891	891-
-891 {+}	-891

If the **SetSignOnLeft** command is executed, then the sign will *always* appear on the left side of the number. The + specification in this case will be superfluous.

### 0 Specifier

The 0 specifier is used to pad the data being displayed with ASCII 0s instead of spaces. The 0 specifier is only meaningful if the size specifier is also used:

**Table 38 Examples for 0 Specifier**

Expression	Output
199 { 0 }	199
199 { 5 }	199
199 { 05 }	199
199 { <05 }	19900

### size Specifier

The *size* specifier defines the width of the expression being displayed. If no size specifier is present, then the width of the data formatted will be equal to the number of characters in the data.

If the *size* specifier is 8, then 8 characters will be displayed, irrespective of the width of the actual data being displayed. The output data will be padded with spaces (unless the 0 specifier is used) or truncated if the size specifier is less than the length of the data to be displayed.

There are two types of size specifiers: absolute and expression. All size specifiers must evaluate to positive integers. Negative numbers and/or decimal values are not allowed.

Absolute specifiers are an integer value, for example, 5. The size specified must *not* begin with a 0, since the 0 will be mistaken for the 0 specifier.

Expression sizes use standard ISL expressions to specify the size. However, the expression must be enclosed in parentheses, or an error will be displayed.

(In the following example, the value of width is assumed to be 3.)

**Table 39 Examples for 0 Specifier**

Expression	Output
"fred"	fred
"fred" { 8 }	fred
"fred" { =8 }	fred
"fred" { (width*2) }	fred
"fred" { width+2 }	ERROR: not enclosed in ( )

### D, X, O, and B Specifiers

The radix specifiers (D, X, O, and B) determine the numeric base of the integer expression being displayed. They have no meaning for decimal and string data. The default is base 10 (D).

**Table 40 Examples for D, X, O, and B Specifiers**

Expression	Output
100	100
100 {H}	64
100 {B}	1100100
100 {08B}	01100100

### :format\_string Specifier

The *format\_string* is the data that follows the colon: specifier. The *format\_string* consists of ASCII characters and the # character. *Format\_strings* are used when the data displayed should be interspersed with spaces and/or other characters to fit conventional display methods. For example, a 10-digit phone number should be displayed as:

(nnn)nnn-*nnnn*

When the SIM encounters a *format\_string*, all # characters will be replaced with data from the preceding expression. All other characters will be output as-is. Characters are replaced starting from the right side of the format string.

Output format specifiers may be used in a format specifier along with the *format\_string* specifier. Any # characters in excess of the expression being formatted are replaced with spaces, unless the 0-output specifier is used.

For example, to display a U.S phone number, assume that the variable `phone_num` contains the phone number and is equal to 3012108000. Also assume that `room_num` contains a room number and is equal to 17031.

**Table 41 Example 1 for: format\_string Specifier**

Expression	Output
<code>phone_num</code>	4432858000
<code>phone_num{:###-###-####}</code>	443-285-8000
<code>phone_num{:###)###-####}</code>	(443) 285-8000
<code>room_num</code>	17031
<code>room_num{:##-###}</code>	17-031
<code>room_num{:Floor ## room ###}</code>	Floor 17 room 031

It may be necessary sometimes to display the # character and not have it replaced with a character from the output expression. In this case, precede the # character with a single quote.

**Table 42 Example 2 for :format\_string Specifier**

Expression	Output
<code>phone_num{:Phone '# ###-###-####}</code>	Phone # 443-285-8000

It is possible to include format specifiers after each expression being formatted in one command. For example:

```
TXMSG room_number { 04 }, guest_name { <24 }, @cknum
```

## Using Input and Output Specifiers Together

Input and output specifiers may be used within the same syntax in the **DisplayInput** and **DisplayMSInput** commands only.

## Command Summary

For quick reference, this section contains an alphabetical listing and brief description of all ISL commands.

**Note:** ISL commands are listed by category in Appendix C

REMEMBER, the commands that require either the **StartPrint** command or **Window** command to operate correctly are listed in the table below with the following designation:

- (P) for StartPrint
- or
- (W) for Window

**Table 43 Commands that Require a StartPrint or a Window Command**

<b>Command</b>	<b>Description</b>
Beep	Sound the beeper.
Break	Break out of the current 'For' loop.
Call	Call a subroutine procedure.
ClearArray	Clear an array.
ClearChkInfo	Clears check information detail lines in buffer.
ClearIslTs	Clear any previously defined touchscreen keys.
ClearKybdMacro	Clear macro key definitions.
ClearRearArea	Clears the contents of the customer display.
ContinueOnCancel	Continue processing script even if the [Cancel] or [Clear] key is pressed after an Input command has been issued.
Display (W)	Display text or a field at a defined place within a window.
DisplayInput (W)	Display an input field within a window.
DisplayInverse	Display input field in inverse video.
DisplayIslTs	Display an ISL-defined touchscreen.
DisplayMSInput (W)	Display an input field within a window and allow magnetic card swipe to satisfy field entry.
DisplayRearArea	Display up to 20 characters on the POS workstation customer display.
DLLCall	Calls a function contained in the DLL. Refer to page 3.
DLLCall_cdecl	Calls a function contained in the DLL using the cdecl convention.
DLLCall_STDCall	Calls a function contained in the DLL using the STDCall convention. Refer to page <a href="#">3_bookmark147</a> .
DLLCallW	Calls a function contained in the DLL with Unicode. Refer to page 3.
DLLFree	Frees a loaded DLL. Refer to page 3.

<b>Command</b>	<b>Description</b>
DLLLoad	Loads an external DLL. Refer to page 3.
ErrorBeep	Sound an error beep.
ErrorMessage	Display an error message and continue.
Event...EndEvent	Indicate the start and end of an Event procedure. The following events are supported: <ul style="list-style-type: none"> <li>• Inq</li> <li>• Tmed</li> <li>• RxMsg</li> <li>• Final_Tender</li> <li>• Print_Header</li> <li>• Print_Trailer</li> </ul>
ExitCancel	Exit a script and cancel the current tendering operation.
ExitContinue	Exit a script and continue the current tendering operation.
ExitOnCancel	Exit a script when the [Cancel] or [Clear] key is pressed after an Input command has been
ExitWithError	Display a defined error message and exit the script.
FClose	Close a file.
FGetFile	Gets a file from the SIM file service:
FLock	Lock a file.
FOpen	Open a file.
For...EndFor	Perform commands a specified number of times.
ForEver...EndFor	Perform commands an indefinite number of times.
Format	Concatenate one or more variables into a string.
FormatBuffer	Format a non-printable string into a printable string.
FormatQ	Concatenate one or more variables into a string and enclose the string in quotes.
FPutFile	Puts a file into the SIM file service server

<b>Command</b>	<b>Description</b>
FRead	Split the next line read from a file into the variables specified in the statement.
FReadBfr	Read the number of bytes specified in the command.
FReadLn	Read the entire line into a string variable.
FSeek	Go to a specified position in an open file.
FUnLock	Unlock a locked file.
FWrite	Write to a formatted file.
FWriteBfr	Write a specified number of bytes.
FWriteLn	Write an entire line.
GetEnterOrClear	Wait for the [Enter] or [Clear] key to be pressed.
GetRxMsg	Wait for a PMS message.
GetTime	Retrieve current time.
If...Else[If]...EndIf	Execute commands if the specified condition is met.
InfoMessage	Display an informational message and continue.
Input	Capture operator entry for a single field or prompt.
Inputkey	Capture operator entry and a key for a single field or prompt.
LineFeed (P)	Linefeed one or multiple lines.
ListDisplay (W)	Display a list.
ListInput (W)	Display a list and get an operator selection.
ListInputEx	Display a list and get an operator selection. Does not provide a WROW or WCOL variable.
ListPrint (P)	Print a list.
LoadDbKybdMacro	Load a pre-defined keyboard macro so that it may be executed upon successful completion of a script.
LoadKybdMacro	Load a user-defined keyboard macro so that it may be executed upon successful completion of a script.

<b>Command</b>	<b>Description</b>
LowerCase	Convert a string to lower-case.
MakeAscii	Remove any non-ASCII or non-printable characters from a string.
MakeUnicode	Remove any non-printable characters from a string.
Mid	Set one portion of a string equal to another string.
MSleep	Sleep for the requested number of milliseconds.
PopUpIsITs	Display a touchscreen as a pop-up.
PrintLine (P)	Print specified text and/or fields.
PrintSimFeatures	Print all SIM features available in current SIM engine.
Prompt	Display an operator prompt.
ProRate	Prorate the itemizers for charge posting.
[Retain/Discard]GlobalVar	Retain or discard global variables between transactions.
Return	Return from a subroutine.
ReTxMsg	Retransmit a message.
RxMsg	Define the format of a message received over the interface.
SaveChkInfo	Insert check information detail into the check.
SaveRefInfo	Save information as tender/media reference detail.
SaveRefInfox	Save information as tender/media reference detail with reference type.
SetIsITsKey	Define a touchscreen key.
SetReRead	Re-read the ISL script for new or changed ISL scripts.
SetSignOn[Left/Right]	The minus sign will go on the left or right side, respectively, when formatting numbers.
SetString	Replace all or a specific number of characters in a string with a particular character.
Split	Break a string into separate fields.

<b>Command</b>	<b>Description</b>
SplitQ	Break a string into separate fields and enclose the string in quotes.
StartPrint...\ EndPrint[FF/NOFF] (P)	Print information on a specified printer, with or without a form feed.
Sub...EndSub	Indicate the start and end of a subroutine procedure.
TimerSet, TimerReset, TimerResetAll	Launch and cancel timer events.
UpperCase	Convert a string to upper-case.
UseBackupTender	Use backup tender programmed in the Symphony database.
Use[Compat/ISL]Format	Use Symphony-standard or ISL message
Use[ISL/STD]TimeOuts	Use ISL time outs or the standard Symphony error messaging when there is no response from the PMS System.
UseSortedDetail	Consolidated detail is accessible.
UseStdDetail	Raw detail is accessible.
Var	Declare a variable field of specified type that will be used for input and/or used in an interface message.
WaitForClear	Wait for the [Clear] key before continuing. If no prompt text is supplied, "Press Clear to Continue" is the default.
WaitForConfirm	Wait for an operator confirmation. If no prompt text is supplied, "Press Enter to Continue" is the default.
WaitForEnter	Wait for the [Enter] key before continuing. If no prompt text is supplied, "Press Enter to Continue" is the default.
WaitForRxMsg	Wait for an interface message to be received after a TxMsg has been sent. If no prompt text is supplied, "Please Wait--Sending Message" is the default.
WaitPrompt/ClearWaitPrmpt	Display a 'wait prompt' dialog while SIM is processing a lengthy operation.
While...EndWhile	Execute a loop structure until an expression becomes FALSE.

---

Command	Description
Window	Create a window of specified size and optionally display a window title.
WindowClose (W)	Close the current window.
WindowEdit[WithSave] (W)	Display the current contents of specified variables within a window and allow them to be edited; optionally require the [Save] key to save entries and exit.
WindowInput[WithSave] (W)	Display the specified fields within a window, without the present contents; optionally require the [Save] key to save entries and exit.

## ISL Command Reference

This section is an A-Z reference of ISL commands. The information for each command is organized into the following categories:

- **Description:** Summarizes the function of the command.
- **Syntax:** Provides the proper way to specify the command and any arguments, as well as a description of each argument.
- **Remarks:** Gives more detailed information of the command, its arguments, and how the command is used.
- **POS Setup:** Provides any Symphony database programming required to issue the command successfully.
- **Example:** Includes an example of the command being used in a script.
- **See Also:** Names related commands, functions, system variables, other documentation to consult, etc.

### Beep

#### Description

This command can be used to sound the beeper at a workstation. It should be used for operator confirmation or notification. Note a separate ErrorBeep command is provided to notify the operator of errors.

---

**Note:** The Beep command does not function because the workstation to beep in Symphony as the “Enable Error Beeper” option is not available in the Enterprise Management Console (EMC).

The command remains so scripts written for legacy products using the Beep command still functions in Symphony.

---

#### Syntax

Beep

---

## See Also

**ErrorBeep** command

## Break

### Description

This is used to break out from a **For** or **Forever** loop. This is especially useful when a **ForEver** loop is executed.

### Syntax

Break

### Remarks

- The Break command will only break out of the **For** or **Forever** loop it is currently in. If the loops are nested, then multiple breaks are required:

```
forever
  forever
    break           //break out of inner loop
  endfor
  break           //break out of outer loop
endfor
```

- If the ability to break out of a nested **For** is required, then use a subroutine and **Return** out of the loop instead:

```
sub break_out

  forever
    for i = 1 to 10
      for num = i to count
        if...
                                return
        endif
      endfor
    endfor
  endfor
endfor
endsub
```

### Example

The following script provides an example of how to break out of a Forever loop:

```
event inq : 1
  var user_input : N6
  forever
    input user_input, "Enter a number and press [ENTER]"
    if user_input > 0 AND user_input <99999
      break
    else
      errormessage "Value outside valid range"
    endif
  endfor
  errormessage "Well done"
endevent
```

## See Also

**For** and **ForEver** command

---

## Call

### Description

This command is used to call a subroutine defined by the Sub command.

### Syntax

Call *name*

**Table 44 Call Command Arguments**

Argument	Description
<i>name</i>	The name of the subroutine defined by the <b>Sub</b>

### Remarks

- The subroutine has access to all the local variables within the Event that called the subroutine, and all global variables in the script file, so these variables may be used to pass parameters. In addition, local variables may be declared in the subroutine.
- When a **Call** is made, ISL will start searching for the subroutine from the top of the program. Therefore, if there are two subroutines with the same name, only the first one will ever get called:

```
event inq:1
  call mysub
endevent

sub mysub                //this one will get called
.
.
.
endsub

sub mysub
                        //this one will not
                        // because it is
                        // preceded by a
                        // subroutine of
                        // the same name
.
.
.
endsub
```

- Up to 32 calls can be nested within a subroutine. If there are anymore, an error will occur.

```
sub mysub
  call mysub            //this will occur 32 times
endsub
```

### Example

The following script will call a subroutine to build a window:

```
event inq : 1
  var win_string : a40 = "This window was built in a subroutine!"

  call msg_window
```

```

        waitforclear
    endevent

    sub msg_window
        window 1, len(win_string) + 2
        display 1, 2, win_string
    endsub

```

## See Also

Sub command

## ClearArray

### Description

This command sets all elements of the specified array equal to zero if the array is numeric, or null if alphanumeric. By default, arrays are initialized in this way when declared.

### Syntax

**ClearArray** *array\_variable*

**Table 45 ClearArray Command Arguments**

Argument	Description
<i>array_variable</i>	The name of the array to clear, based on the name of a <i>user_variable</i>

### Example

The following script allows the user to send up to a 13-line message to the kitchen printer. Before sending to the printer, it allows the user the opportunity to edit their work. If the user presses clear when prompted, the *array\_variable* is cleared, and the user can retype a message.

```

event inq : 1
    var kitchen_msg[13]: a20
    var sender_name: a20
    var rowcnt : n3
    var term_key : key
    var data_entered: a20

    forever
        call get_message
        window 1, 66
        display 1, 2, "PAGE UP=edit, CLEAR=retype, ENTER=send, CANCEL="quit"
        inputkey term_key, data_entered, ""
        if term_key = @KEY_ENTER
            break
        elseif term_key = @KEY_CLEAR
            cleararray kitchen_msg
        elseif term_key = @KEY_CANCEL
            exitcontinue
        endif
    endfor
    call print_message
endevent
sub get_message
    window 14, 22

```

---

```

        displayinput 1, 2, sender_name, "Enter your name"
        for rowcnt = 1 to 13
            displayinput rowcnt + 1, 2, kitchen_msg[rowcnt], "Enter kitchen
message"
        endfor
        windoweditwithsave
    endsub
    sub print_message startprint @ordr1
        printline "======"
        printline "Message from ", sender_name
        printline "======"
        for rowcnt = 1 to 136
            if len(kitchen_msg[rowcnt]) > ""
                printline kitchen_msg[rowcnt]
            endif
        endfor
        printline "=====  
END MESSAGE  
======"
    endprint
endsub

```

## ClearChkInfo

### Description

This command clears any check information detail lines that have not been written to the Guest Check files and are stored in the guest check information buffer.

Normally, this command is used if the script added information to the buffer, but later decides the information should not be saved in the Guest Check Files.

### Syntax

**ClearChkInfo**

### Remarks

- Check information detail is a type of check detail that can be stored in the Guest Check files via the **SaveChkInfo** command. Typically check information detail lines are used to store customer information, such as name and address, so that it can print on a guest check or a remote order device.
- This command is executed upon exiting the script.
- Keep in mind that, like other types of guest check detail, such as totals and definitions, guest check information detail lines are only stored in the Guest Check files temporarily and cleared upon closing a guest check.

### POS Setup

Refer to the detail description of **SaveChkInfo** for a brief discussion of the usage of check information detail.

### Example

The subroutine below requires that the operator input a string five times, then prompts the operator to confirm saving the information. If the operator responds by pressing the [Clear] key, the check information detail is discarded; otherwise, the information is saved.

```

sub get_info
    var string : A20
    var answer : N5

```

---

```
var i : N5
for i = 1 to 5
    input string, "Enter string ", i
    savechkinfo
endfor
getenterorclear answer, "Save information?"
if answer = 0
    clearchkinfo
endif
endsub
```

## See Also

SaveChkInfo command

## ClearIsITs

### Description

This command clears any touchscreen keys that have been defined using the **SetIsITsKey** command.

### Syntax

ClearIsITs

### Remarks

All previously defined keys are cleared each time a script executes.

After a touchscreen has been displayed, its keys remain defined, thus, Oracle Restaurants recommends using the **ClearIsITs** command to clear previously defined touchscreen keys when building two or more touchscreens in the same event.

### Example

The following example is a subroutine (create\_ts) that clears previously defined touchscreen keys before calling another subroutine (set\_keys), one that will build a new touchscreen.

```
sub create_ts
clearisits                                //Clear out any previously
                                           // defined touchscreen keys
call set_keys                               //Build the keys needed
.
.
.
endsub
```

## See Also

DisplayIsITs, PopUpIsITs, and SetIsITsKey commands

## ClearKybdMacro

### Description

This command will clear out any macro keys that have been defined by the **LoadKybdMacro** or **LoadDbKybdMacro** commands since the script started.

---

## Syntax

### ClearKybdMacro

## Remarks

All macro keys are cleared out when the script is started.

## Example

For example, this command may be used if the **LoadKybdMacro** command were issued, but the response from the PMS system was incorrect; the **ClearKybdMacro** would be used to clear the macro in preparation for a rebroadcast or transaction cancel.

```
event inq:1
  loadkybdmacro 11:841                //Load PMS 1 Inquiry Key
  txmsg "inq_1_request"
  waitforrxmsg
endevent

event rxmsg : inq_1_reply
  var status : n5
  rxmsg status
  if status = 0
    errormessage "No Response from PMS "
    clearkybdmacro
  else
    waitforclear "Press Enter to Continue "
  endif
endevent
```

## See Also

LoadKybdMacro and LoadDbKybdMacro command

## ClearRearArea

### Description

This command will clear the contents of the customer display.

### Syntax

#### ClearRearArea

### Example

```
event inq:1
  DisplayRearArea "Hello"
  WaitForClear "Press clear to clear display"
  clearreararea
end event
```

## See Also

DisplayRearArea command

## ContinueOnCancel

### Description

This command will continue processing the script even if the [Cancel] or [Clear] key is pressed after an **Input** command is issued.

---

## Syntax

### ContinueOnCancel

## Remarks

- In normal operations, when ISL is waiting for user data after an **Input** command is issued (for example, **Input**, **WindowInput**, **WindowEdit**) and the user presses the [Cancel] key or the [Clear] key at the input prompt, the script will terminate. It may be necessary for the script to continue even if the user has cancelled the entry. If the **ContinueOnCancel** command is executed, then the **Input** commands will not terminate the script if the [Cancel] key or the [Clear] key is pressed. Instead, they will return to the line after the Input command. The @INPUTSTATUS system variable will be set to 0 if the user cancelled the input, or 1 if valid data was entered.
- If the **ContinueOnCancel** is used, the script should check all **Input** commands to determine if the user cancelled the input or not.

## See Also

ExitCancel, ExitOnCancel, Input, WindowEdit, and WindowInput commands

## Display

### Description

This command can be used to display a message in a window.

### Syntax

**Display** *row, column, expression* [{*output\_specifier*}] \ [, *expression* [{*output\_specifier*}]...]

**Table 46 Display Command Arguments**

Argument	Description
<i>row</i>	The integer <i>expression</i> specifying the screen <i>row</i> within the defined window where the message will be displayed
<i>column</i>	The integer <i>expression</i> specifying the screen <i>column</i> within the defined window where the message will be displayed
<i>expression</i>	An <i>expression</i> to be displayed; it may be one of the following: <ul style="list-style-type: none"><li>• <i>user_variable</i></li><li>• <i>system_variable</i></li><li>• <i>constant</i></li><li>• <i>string</i></li><li>• <i>function</i></li><li>• <i>equation</i></li></ul>

Argument	Description
<i>{output_specifier}</i>	The integer <i>expression</i> specifying the screen <i>column</i> within the defined window where the message will be displayed.

### Remarks

- Since this command provides information about where to locate the text or fields within the window, a **Window** command must have been executed prior to this command
- The **Display** *row* and *column* must fall within the boundaries of the defined window.
- An error will occur if the data to be displayed extends past the end of the window:

```
window 10, 10, "10 columns"
```

```
//ERROR!
```

```
display 1, 1, "this line is greater than 10 columns"
```

### Example

The following script will display a guest room number and name in a window:

```
event rxmsg : room_info
  var room_num : a5
  var guest_name : a20
  rxmsg room_num, guest_name
  window 1, 40
  display 1, 2, "The guest in room ", room_num, " is ", guest_name
  waitforclear
endevent
```

### See Also

Window command; Chr function

## DisplayInput

### Description

This command defines an input field within a window. Thus, a Window command must have been executed prior to this command. In addition, a **WindowEdit** or **WindowInput** must follow it, or the grouping of **DisplayInput** commands to which it belongs.

### Syntax

**DisplayInput** *row*, *column*, *input\_variable*[[*input/output\_specifier*]], \ *prompt\_expression* [, *prompt\_expression*]

**Table 47 DisplayInput Command Arguments**

Argument	Description
<i>row</i>	The integer <i>expression</i> specifying the screen <i>row</i> within the defined window where the <i>input_variable</i> will be displayed.
<i>column</i>	The integer <i>expression</i> specifying the screen <i>column</i> within the defined window where the <i>input_variable</i> will be displayed.
<i>input_variable</i>	An <i>array_variable</i> or <i>user_variable</i> that allows user input.
{ <i>input/output_specifier</i> }	One or more of the <i>input</i> and <i>output_specifiers</i> that determine the format of all input and output fields; see full definition on pages 8-3 through 8-6.
<i>prompt_expression</i>	An <i>expression</i> displayed on the prompt line, usually to instruct the user what to enter; it may be one of the following: <ul style="list-style-type: none"> <li>• <i>user_variable</i></li> <li>• <i>system_variable</i></li> <li>• <i>constant</i></li> <li>• <i>string</i></li> <li>• <i>function</i></li> <li>• <i>equation</i></li> </ul>

**Remarks**

- The **DisplayInput** *row* and *column* must fall within the boundaries of the defined window.
- The *prompt\_expression* is required.
- **DisplayInput** can be used with the **WindowEdit**\Input commands to build a screen of input fields to accept input from the user. Navigating among the input fields is achieved with the movement keys: up arrow, down arrow, home, and end. [Enter] can also be used to navigate, which moves the focus to the next field, and [Clear], which moves the focus to the previous field.
- When a **WindowEdit** or **WindowInput** command is executed, each field displayed using the **DisplayInput** command will be edited in turn.
- The **DisplayInput**, **DisplayMSInput**, **Input**, and **InputKey** commands are the only commands that act on both the Input and Output Specifiers.
- The maximum number of window input entries allowed is 64.

```
for i = 1 to 65
  displayinput 1, i, a[i], "Enter ", i
  // error when i is 65
endfor
```

- If the *input\_variable* to be displayed extends past the end of the window, then an error will occur on the **WindowEdit** or **WindowInput** command, and not the **DisplayInput** command.
- **WindowInput** fields can be edited using the in-place keyboard entry editing feature. The following Type 9 (Keypad) **keycodes** assign commands to specific keys in the keyboard or touchscreen files:
  - #19—Edit
  - #20—Edit Delete
  - #21—Edit Insert Tggl
- A keyboard entry field can be greater than the 40 characters allowed in a displayed entry field.

### Example

The following script will allow input of customer information in a window:

```
event inq : 1
  var rowcnt: n3
  var field_name[5] : a15
  var customer_info[5]: a20
  field_name[1] = "Customer name:"
  field_name[2] = "Company:"
  field_name[3] = "Address:"
  field_name[4] = "City:"
  field_name[5] = "Phone:"

  window 5, 36
  for rowcnt = 1 to 5
    display rowcnt, 2,
      field_name[rowcnt]
    displayinput rowcnt, 16, customer_info[rowcnt], \
      "Enter ", field_name[rowcnt]
  endfor
  windowedit
endevent
```

### See Also

**Window**, **WindowEdit**, and **WindowInput** commands

## DisplayInverse

### Description

This command can be used to display a message in a window in inverse video. Since this command provides information about where to locate the text or fields within the window, a **Window** command must have been executed prior to this command.

### Syntax

**DisplayInverse** *row, column, expression*[*output\_specifier*] \ [, *expression*[*output\_specifier*]]...

**Table 48 Display Inverse Command Arguments**

Argument	Description
<i>row</i>	The integer <i>expression</i> specifying the screen <i>row</i> within the defined window where the message will be displayed
<i>column</i>	The integer <i>expression</i> specifying the screen <i>column</i> within the defined window where the message will be displayed
<i>expression</i>	An <i>expression</i> to be displayed; it may be one of the following: <ul style="list-style-type: none"> <li>• <i>user_variable</i></li> <li>• <i>system_variable</i></li> <li>• <i>constant</i></li> <li>• <i>string</i></li> <li>• <i>function</i></li> <li>• <i>equation</i></li> </ul>
{ <i>output_specifier</i> }	One or more of the <i>output_specifiers</i> which determine the format of the output fields; see full definition on pages 8-3 through 8-6.

**Remarks**

- The **DisplayInverse** *row* and *column* must fall within the boundaries of the defined window.
- An error will occur if the data to be displayed extends past the end of the window:

```
window 10, 10, "10 columns"
```

```
//ERROR!
```

```
displayinverse 1, 1, "this line is greater than 10 columns"
```

**Example**

The following script will display a guest room number and name in a window:

```
event rxmsg : room_info var room_num : a5
  var guest_name : a20
  rxmsg room_num, guest_name
  window 1, 40
  displayinverse 1, 2, "The guest in room ", room_num, " is ", guest_name
  waitforclear
endevent
```

**See Also**

**Display and Window commands**

---

## DisplayIsITs

### Description

This command displays a touchscreen defined by the **SetIsITsKey** command.

### Syntax

**DisplayIsITs**

### Remarks

- After a touchscreen has been displayed, its keys remain defined until cleared by the **ClearIsITs** command or until the script terminates
- Sixty temporary touchscreen keys are available.

### Example

The subroutine below first clears any previously defined touchscreen keys and displays two touchscreen keys, [YES] and [NO], using the **DisplayIsITs** command. This subroutine displays these keys as the operator is issued a prompt by the system and captures the operator's input.

```
sub get_yes_or_no( ref answer, var prompt_s:A38 )
  var keypress : key
  var data : A20

  clearisltts
  setislttskey 2, 2, 4, 4, 3, @KEY_ENTER, "YES"
  setislttskey 2, 6, 4, 4, 3, @KEY_CLEAR, "NO"
  displayisltts

  inputkey keypress, data, prompt_s
  if keypress = @KEY_ENTER
    answer = 1
  else
    answer = 0 endif
endsub
```

### See Also

**ClearIsITs**, **PopUpIsITs**, and **SetIsITsKey** commands

## DisplayMSInput

### Description

This command defines an input field within a window; therefore, a **Window** command must have been executed prior to this command, and a **WindowEdit** or **WindowInput** must follow it. This command defines an input field within a window that may be entered through the keyboard or touchscreen, or by swiping a magnetic card through the magnetic card reader on the workstation.

### Syntax

**DisplayMSInput** *row, column, input\_variable* \ [*input/output\_specifier*], *prompt\_expression* [, *row, column, \ input\_variable*{*input/output\_specifier*}, *prompt\_expression*]

**Table 49 DisplayMSInput Command Arguments**

<b>Argument</b>	<b>Description</b>
<i>row</i>	The integer <i>expression</i> specifying the screen <i>row</i> within the defined window where the <i>input_variable</i> is displayed.
<i>column</i>	The integer <i>expression</i> specifying the screen <i>column</i> within the defined window where the <i>input_variable</i> is displayed.
<i>input_variable</i>	An <i>array_variable</i> or <i>user_variable</i> that allows user input.
{ <i>input/output_specifier</i> }	One or more of the <i>input</i> and <i>output_specifiers</i> that determine the format of all input and output fields; see full definition on pages 8-3 through 8-6.
<i>prompt_expression</i>	An <i>expression</i> displayed on the prompt line, usually to instruct the user what to enter; it may be one of the following: <ul style="list-style-type: none"> <li>• <i>user_variable</i></li> <li>• <i>system_variable</i></li> <li>• <i>constant</i></li> <li>• <i>string</i></li> <li>• <i>function</i></li> <li>• <i>equation</i></li> </ul>

**Remarks**

- This command allows the designer to specify the fields that the operator can enter manually, fields that may be entered from a magnetic card swipe, or fields that may be entered in both fashions. In addition, the location and length of the data to be used on the magnetic card stripe may also be defined.
- After the **WindowInput** command is executed, the system variable @MAGSTATUS will be set to Y if the magnetic card was swiped during the **WindowInput**. It will be set to N if a magnetic card was not swiped. To use @MAGSTATUS in this way, use only one **DisplayMSInput** command with each **WindowInput** entry (otherwise, @MAGSTATUS will be undefined). If more than one **DisplayMSInput** command is needed, use the Len function to check if the input string is set to zero (see “ISL Functions” for an explanation of the Len function).
- The *prompt\_expression* is required.
- **DisplayMSInput** can be used with the **WindowEdit\Input** commands to build a screen of input fields to accept input from the user. Navigating among the input fields is achieved with the movement keys: up arrow, down arrow, home, and

---

end. [Enter] can also be used to navigate, which moves the focus to the next field, and [Clear], which moves the focus to the previous field.

- The **DisplayInput**, **DisplayMSInput**, **Input**, and **InputKey** commands are the only commands which act on both the Input and Output Specifiers (see page 8-2 for more information).
- The maximum window input entries allowed is 64.

```
for i = 1 to 65
    displayinput 1, i, a[i], "Enter ", i
// error when i is 65
endfor
```

- If the *input\_variable* to be displayed extends past the end of the window, then an error will occur on the **WindowInput** command, and not the **DisplayInput** command.
- In the case where row and column is 0, the input field (for example, *cardholder\_name*) is considered hidden and will not be displayed; additionally, it can only be satisfied with a magnetic card, which means no keyboard input is allowed.

```
displaymsinput 0, 0, cardholder_name{m1, 2, 1, *}, \ "Enter Guest Name",...
```

There can be more than one hidden field in a **DisplayMSInput** command. In most cases, the input specification for this field will contain magnetic stripe information.

- The *prompt\_expression* for all hidden field(s) will be ignored.

## Example

The following script will read the information from Track 1 of a credit card:

```
event inq : 1
    var cardholder_name: a26
    var account_num: n19
    var expiration_date: n4
    var track1_data: a79

    window 3, 78
    displaymsinput 1, 2, cardholder_name{m1, 2, 1, *}, "Enter Guest Name", \
        2, 2, account_num{m1, 1, 1, *}, "Enter Account Number", \
        3, 2, expiration_date{m1, 3, 1, 4}, "Enter Expiration"

    windowinput
    waitforclear
endevent
```

## See Also

**Window**, **WindowEdit**, and **WindowInput** commands; **Len** function

## DisplayRearArea

### Description

This command will display up to 20 characters on the POS workstation customer display (rear display).

This command works on 20-character displays only—8-character displays are ignored.

### Syntax

**DisplayRearArea** *expression*[[*output\_specifier*]] [*expression*[[*output\_specifier*]]...]

---

## Example

```
event inq:1
  var text:80
  input text, "Enter data"
  displayreararea "Data:", text
end event
```

## See Also

**ClearRearArea** command

## DLLCall

### Description

This command will call a function contained in the DLL.

### Syntax

**DLLCall** *handle, dll\_name*( [*parm1* [*parm2* [*parm3...*]]] )

## See Also

- **DLLCallW**, **DLLFree**, and **DLLLoad** commands
- Appendix F—Windows DLL Access

## DLLCall\_cdecl

### Description

This command will call a function contained in the DLL using the cdecl convention.

### Syntax

**DLLCall\_cdecl** *handle, dll\_name*( [*parm1* [*parm2* [*parm3...*]]] )

## See Also

- **DLLCallW**, **DLLFree**, and **DLLLoad** commands
- Appendix F—Windows DLL Access

## DLLCall\_STDCALL

### Description

This command will call a function contained in the DLL using the STDCALL convention.

### Syntax

**DLLCall\_STDCALL** *handle, dll\_name*( [*parm1* [*parm2* [*parm3...*]]] )

## See Also

- **DLLCallW**, **DLLFree**, and **DLLLoad** commands
- Appendix F—Windows DLL Access

---

## DLLCallW

### Description

This command will call a function contained in the DLL with Unicode.

### Syntax

`DLLCallW handle, dll_name( [parm1 [parm2 [parm3...]]] )`

### See Also

- `DLLCall`, `DLLFree`, and `DLLLoad` commands
- Appendix F—Windows DLL Access

## DLLFree

### Description

This command will free a loaded DLL.

### Syntax

`DLLFree handle`

### See Also

- `DLLCall`, `DLLCallW`, and `DLLLoad` commands
- Appendix F—Windows DLL Access

## DLLLoad

### Description

This command will load the external DLL. The `dllload` command needs to be called only once during the lifetime of the SIM script.

### Syntax

`DLLLoad handle, name`

### Example

```
event inq:1
  var dll_handle:N9
  dllload dll_handle, "myops.dll"
end event
```

### See Also

- `DLLCall`, `DLLCallW`, and `DLLFree` commands
- Appendix F—Windows DLL Access

## ErrorBeep

### Description

This command can be used to sound the error beeper at the workstation.

---

**Note:** The ErrorBeep command currently does not because the workstation to beep in Symphony as the “Enable Error Beeper” option is not available in the Enterprise Management Console (EMC).

The command remains so scripts written for our legacy products using the ErrorBeep command will still function in Symphony.

---

## Syntax

ErrorBeep

## See Also

Beep command

## ErrorMessage

### Description

This command can be used to display an error message at the workstation when an incorrect entry is made by the operator.

### Syntax

**ErrorMessage** *expression* [{*output\_specifier*}], *expression* \ [{*output\_specifier*}]...

**Table 50 Error Message Command Arguments**

Argument	Description
<i>expression</i>	An <i>expression</i> to be displayed; it may be one of the following: <ul style="list-style-type: none"><li>• <i>user_variable</i></li><li>• <i>system_variable</i></li><li>• <i>constant</i></li><li>• <i>string</i></li><li>• <i>function</i></li><li>• <i>equation</i></li></ul>
{ <i>output_specifier</i> }	#one or more of the <i>output_specifiers</i> that determine the format of the output fields; see full definition on pages <a href="#">8-3</a> through <a href="#">8-6</a> .

### Remarks

The **ErrorMessage** command expects one error line to be displayed. However, the UWS displays two lines. The error line to be displayed is broken up between the two logical lines. If the line is too long to be displayed, it will be truncated.

### See Also

InfoMessage

### Example

The following script will display a message indicating that an entry is invalid:

```

event inq : 1
  var menu_choice: n3

  window 3, 23
  display 1, 2, "[1] Edit member info"
  display 2, 2, "[2] Add new member"
  display 3, 2, "[3] Exit"
  forever
    input menu_choice, "Choose a number and press [ENTER]."
    if menu_choice < 1 or menu_choice > 3
      errormessage "Choice [", menu_choice, "]is outside the valid",\
"range"
    else
      break
    endif
  endfor
endevent

```

## Event...EndEvent

### Description

The Event command indicates the start of a procedure associated with an operator inquiry, payment, an interface response message or printing addition information on the check header or trailer lines. The **EndEvent** indicates the end of the event procedure.

- If the \* specifier is present in an Event line, in the Event ID field, then the Event will be executed if the Event types match, regardless of the Event ID. The \* specifier affects the following events: **Inq**, **Tmed**, **RxMsg**, and **Final\_Tender**. For example, the following Event will catch all Inquire Events:

```

event inq : *

endevent

```

- It is possible to write an **Event Inq** or **Event Tmed** as an expression. Example:

```

event inq : 5

```

Can be defined as:

```

event inq : ( 2 + 3 )

```

In addition, variables may also be used, but must be defined as global variables. For example:

```

var guest_inq_number : N5 = 5

event inq : guest_inq_number

```

- The **EndEvent** command cannot be used within a subroutine.

### Syntax 1

**Event Inq** : *number*

**Table 51 Event Inq Command Arguments**

Argument	Description
<i>number</i>	Corresponds to a pre-defined SIM Inquiry key programmed in the Symphony database, or * to execute the <b>Event</b> whenever it is encountered

---

### Remarks 1

- The **Event Inq** command is executed when a SIM Inquiry key is used at a workstation.
- The valid entry for number is 1 through 20.

### Example 1

This is an example of a standard Inquiry event:

```
event inq : 1
  var menu_choice: n3
  window 3, 23
  .
  .
  .
Endevent
```

### Syntax 2

Event **Tmed** : *number*

**Table 52 Event Tmed Command Arguments**

Argument	Description
<i>number</i>	Corresponds to a pre-defined SIM Inquiry key programmed in the Symphony database, or * to execute the <b>Event</b> whenever it is encountered

### Remarks 2

- The **Event Tmed** command is executed when an ISL Tender key is used at the workstation.
- The Tender number must be an object number in the Tender Media module. It is required that the Tender Media PMS Option, **Use ISL TMED Procedure Instead of PMS Interface** is enabled, and the workstation must be within a transaction for this Event to work. For a complete explanation, see [Step 5: Create a SIM Tender Key](#).

### Example 2

This is an example of a standard Tender/Media event:

```
event tmed : 10 var rowcnt : n3
  var deliv_desc[6] : a15
  deliv_desc[1] = "Name:"
  window 6, 43
  .
  .
  .
endevent
```

---

### Syntax 3

Event RxMsg : *event\_ID*

**Table 53 Event RxMsg Command Arguments**

Argument	Description
<i>event_ID</i>	The first field in the response message that identifies the event that is expecting that response

### Remarks 3

- The first field in a response message is always the *event\_ID* and should not be used in any successive **RxMsg** variable. The *event\_ID* must begin with a letter A - Z, a - z, or the underline character (), and it can be up to 255 characters in length.
- When a message has been received from the PMS, the ISL will search the script for an **RxMsg** event whose event type matches the first field in the application\_data segment of the message. If ISL encounters a message of the form: Event **RxMsg** : \* it will automatically run that event without regard to the PMS message's first field value. This feature is useful for debugging ISL scripts when the message from the PMS may not be correct.
- The Event **RxMsg** command is executed when SIM has been instructed to wait for a response and a response is received from the interfaced system. This event requires that both the **TxMsg** and **WaitForRxMsg** commands be used in another event, in the script file, for the **RxMsg** command to work.
- If the **UseISLTimeOuts** command is used and the PMS does not respond to an ISL message within the timeout period, the ISL will search the script for an **RxMsg** event with an *event\_ID* of **\_Timeout (Event RxMsg : \_Timeout)**. If **\_Timeout** is found, ISL will bypass the standard Symphony error messaging and process a user defined ISL instruction in its place.
- The interface application data message fields are always separated by an ASCII field separator character (1CH).

### Example 3a

This is an example of a standard response message event:

```
event inq : 1
  var room_num : a4
  input room_num, "Enter Room Number"
  txmsg "charge_inq",@CKEMP,@CKNUM,@TNDTTL,room_num

is a                                     //The first field (charge_inq)
string                                  // example of an identifying
process                                  // that the POS might use to

  waitforrxmsg                           // message from the POS.
  endevent
  event rxmsg : charge_declined           //This is one of the PMS

response                                 // possibilities

  var room_num : a4
  rxmsg room_num
```

---

```
        exitwitherror "Charge for room ", room_num," declined"
    endevent
```

### Example 3b

This is an example of an event that is run when the response message is not received within the ISL timeout period:

```
useisltimeouts

event tmed : 10

    var room : N5
    input room, "Enter room number"
    txmsg "CHARGE", room, @tndttl
    waitforrxmsg
endevent
event rxmsg : charge_response
    waitforclear "Posting successful"
endevent
event rxmsg : _timeout
    window 4, 30
    display 2, @center, "PMS is down."
    display 3, @center, "Post to alternate tender?"
    waitforconfirm
    usebackuptender
endevent
```

### Syntax 4

#### Event Final\_Tender

#### Remarks 4

- This event is called after the last tender has occurred, but just before the check is closed. This event is a separate event from the **Event Tmed** event. An **Event Tmed** event is used to post the tender, while the **Event Final\_Tender** is used when the check has been completely tendered.

For example, one could use the **Event Final\_Tender** to implement the following features with the ISL:

- Creating a specialized printout of a guest check for which neither the **Event Inq** nor **Tmed** can be called when all the check detail is in the check.
- Sending log information to a PMS containing all the check information.
- If the **Event Final\_Tender** is not present in the script, no error will occur.
- Unlike the **Event Tmed**, when using the **Event Final\_Tender** command, a tender does not need to be linked to a PMS by Tender Media PMS Option, Use ISL TMED Procedure Instead of PMS Interface.
- When the **Event Final\_Tender** is executed, the ISL will execute the event for each script linked to a PMS Computer. For example, if pms1.isl and pms2.isl both include an **Event Final\_Tender**, the ISL will process both scripts.
- There is no *event\_ID* field for the **Event Final\_Tender**.

The **Print\_Header** and **Print\_Trailer** events, along with some new SIM system variables (see 6-110 and 6-205) and a specific set of control characters are used to print information on checks and receipts. This information can be printed in the header and/or trailer of

Customer Receipts, Guest Checks, and Credit Card Vouchers. This information can include text, bar codes, estimated tip amounts, or any function a SIM script can perform.

### Syntax 5

Event Print\_Header : <alpha/numeric >

Event Print\_Trailer : <alpha/numeric >

**Table 54 Event Print\_Header and Event Print\_Trailer Command Arguments**

Argument	Description
<i>alphanumeric</i>	Corresponds to an entry in the <i>RVC Descriptors</i> module in the Enterprise Management Console (EMC)

### Remarks

Control Characters:

@@<event ID argument>

Control characters and SIM event(s) are programmed in the *RVC Descriptors* module. The combination of the control characters and the SIM event will call a SIM script, and the additional text or bar code is printed on either the header or trailer.

### Example 1

For example, using the event called "est\_tip\_amt" the Credit Card Voucher Header lines in the *RVC Descriptors* module will be programmed something like this:

```

1 Tip Amount _____
2 Estimated Tip Amount:
3 @@est_tip_amt
4
5 Total _____
6
7
8 -----
9 Signature

```

When POS Operations starts printing the credit card voucher trailer, it will print line 1 and 2 as the part of the header, when the event argument (@@est\_tip\_amt) at line 3 is recognized, POS Operations will call the SIM script.

### Example 2

For example, the following portion of a SIM script will be called by the credit card voucher trailer, and will printout the estimated tip amount on the credit card voucher:

```

event print_trailer : est_tip_amt

    format @trailer[1] as "EST TIP AMT      $", ( @ttl due
* 15 ) / 100
    format @trailer[2] as "      "

endevent

```

---

After the SIM script is finished, POS Operations will continue printing the remaining lines on the credit card voucher.

Once the SIM script is called, the script will instruct POS Operation what to print and how to format it. The system variables, @HEADER (see page 7-60) and

@TRAILER (see page 7-99), support this function.

- The maximum number of SIM events available is the same as the number descriptor lines available in the header and trailer fields. If there are 6 header lines available, then 6 SIM events can be used.

For example, if printing a CA voucher header (a total of 6 lines) which contained text on line number 1 and 2, then called a SIM event on line 3 that would leave 3 lines available to print information from within the SIM script. For example, one cannot print 5 of 6 lines of a header, then on the 6th line call a SIM script which prints 5 more lines of text. If the SIM script calls for 5 lines, only 1 line will print, as 5 of the 6 lines have already printed.

- The event argument should consist of only letters, numbers, and an underscore (no spaces or punctuation). Also, the first character must be a letter. For example: @@voucher is a valid entry, @@5voucher would be an invalid entry. Maximum length of the descriptor is 30 characters, plus 2 control characters, which is a total of 32.
- More than one event argument (@@) can be embedded in a trailer.
- The @HEADER[] and @TRAILER[] arrays are unique to each event. This means that each event can begin writing to the array starting at index 1, rather than at the next available index. In the example above, both events started formatting at index 1.
- All transaction system variables are still valid in these events. User input is still allowed as are file operations and display manipulation.
- The events are called when POS Operations is formatting the print data, and not printing it. Therefore, startprint and other SIM commands can be used to generate printouts while the formatting process takes place.
- If the event is not found in the SIM script, then no error is given. The @@ line is ignored.

### **See Also**

**Format, RxMsg, TxMsg, UseBackupTender, UseISLTimeOuts, UseSTDTimeOuts, Var,** and **WaitForRxMsg** commands

## **ExitCancel**

### **Description**

This command should be used to exit the current script and cancel the current POS tendering operation.

### **Syntax**

**ExitCancel**

---

## Remarks

This command might be useful if charge posting was denied.

## Example

The following example will either allow a check to be tendered to a room charge or prevent the room charge from being posted:

```
event tmed : 9
  var room : a6
  var guest_name : a20

  window 4, 22, "Room Charge"
  displayinput 2, 2, room, "Enter room number"
  displayinput 3, 2, guest_name, "Enter guest name"
  windowinput
  txmsg "room_charge", room, guest_name
  waitforrxmsg
endevent

event rxmsg : post_response
  var status : a10
  var room : a6
  var guest_name : a40

  rxmsg status, room, guest_name
  if status = "accept"
    exitcontinue
  elseif status = "deny"
    errormessage "Room charge denied"
    exitcancel
  else
    call get_more_info( room, guest_name )
  endif
endevent
```

## ExitContinue

### Description

This command should be used to end the current script and continue processing the POS tendering operation.

### Syntax

**ExitContinue**

### Remarks

- This might be useful if tendering should continue after a guest charge is approved.
- Do not confuse the **ExitContinue** command with the **EndEvent** command. **EndEvent** acts as both an Event procedure delimiter and an implicit **ExitContinue**.
- Do not use the **EndEvent** command instead of the **ExitContinue** command.

### Example

The following example will either allow a check to be tendered to a room charge or prevent the room charge from being posted:

---

```

event tmed : 9
  var room : a6
  var guest_name : a20

  window 4, 22, "Room Charge"
  displayinput 2, 2, room, "Enter room number"
  displayinput 3, 2, guest_name, "Enter guest name"
  windowinput
  txmsg "room_charge", room, guest_name
  waitforrxmsg
endevent

event rxmsg : post_response
  var status : a10
  var room : a6
  var guest_name : a40

  rxmsg status, room, guest_name
  if status = "accept"
    exitcontinue
  elseif status = "deny"
    errormessage "Room charge denied"
  exitcancel
  else
    call get_more_info( room, guest_name )
  endif
endevent

```

## ExitOnCancel

### Description

This command will exit the script when the [Cancel] key or the [Clear] key is pressed after an **Input** command has been issued.

### Syntax

**ExitOnCancel**

### See Also

**ContinueOnCancel**, **ExitCancel**, and **ExitContinue** commands

## ExitWithError

### Description

This command is used to display an error message and cancel the current POS tendering operation.

### Syntax

**ExitWithError** *error\_message*[*output\_specifier*] [, *error\_message* \ [*output\_specifier*]]...

**Table 55 ExitWithError Command Arguments**

Argument	Description
<i>error_message</i>	An <i>expression</i> displayed in the error banner, usually to instruct the user of a problem; it may be one of the following: <ul style="list-style-type: none"> <li><i>user_variable</i></li> <li><i>system_variable</i></li> <li><i>constant</i></li> <li><i>string</i></li> <li><i>function</i></li> <li><i>equation</i></li> </ul>
{ <i>output_specifier</i> }	One or more of the <i>output_specifiers</i> that determine the format of the output fields; see the full definition on pages 8-3 through 8-6.

**Remarks**

The *error\_message* is required.

**Example**

The following script illustrates how this command will display an error if a charge is denied:

```
event rxmsg : charge_declined
    var room_num : a4

    rxmsg room_num

    exitwitherror "Charge for room ", room_num, " declined"
endevent
```

**FClose**

**Description**

This command closes a file that was previously opened by the FOpen command.

**Syntax**

**FClose** *file\_number*

**Table 56 FClose Command Arguments**

Argument	Description
<i>file_number</i>	An integer variable which was assigned in the <b>FOpen</b> statement when the file was opened

**Remarks**

- The *file\_number* specified must be a valid file number. That is, it must correspond to a file already opened. Otherwise, an error message will be generated.

- All files are automatically closed at the end of a script.

### Example

The following example would open a file, read from it, and then close it:

```
event inq: 1

    var fn : n5
    fopen fn, "/micros/simphony/data/emplist.dat", read
    .
    .
    .
    fclose fn
```

*endevent*

### See Also

FOpen command

## FGetFile

### Description

This command gets a file from the SIM file service.

### Syntax

**FGetFile** *RemoteFileName, LocalFileName, Status*

**Table 57 FGetFile Command Arguments**

Argument	Description
<i>RemoteFileName</i>	Relative to "SimDataFiles" directory in \MICROS\Simphony\EGatewayService
<i>LocalFileName</i>	Relative to the location of SarOps.exe (..\PosClient\bin) directory on the workstation
<i>Status</i>	Will contain result of operation after completion. A status of "0" (zero) indicates the file retrieval was successful. A status of any non-zero value indicates the file retrieval failed.

### Remarks

All files are automatically closed at the end of a script.

### See Also

FPutFile command

---

## FLock

### Description

This command locks a file to prevent other processes from writing to the file, usually while it is open.

### Syntax

**FLock** *file\_number*, [**Preventwrite**] [**And**] [**Preventread**] [**and**]\ [**Nonblock**]

**Table 58 Flock Command Arguments**

Argument	Description
<i>file_number</i>	Identifies the file to be locked; an integer variable which was assigned in the <b>FOpen</b> statement when the file was opened.
<b>Preventwrite</b>	A mode separator that prevents others from writing to the specified file, while the lock is in place.
<b>And</b>	Required by syntax if more than one mode separator is issued.
<b>Preventread</b>	Required by syntax if more than one mode separator is issued.
<b>Nonblock</b>	The <b>FLock</b> command will return immediately, whether the lock was successful or not.

### Remarks

- The purpose of this command is to implement cooperative file locking among processes. Since ISL scripts execute in a multiprocessing environment, it may be necessary for one script to write to a file at the same time another needs to read from it. Without any type of synchronization, corrupted data may be read from or written to the file. (Within this explanation, the terms script and process both refer to the POS Operation process which executes the script.)
- The ISL file locking model is based on the file locking model of the underlying Windows operating system. Files can be locked so that other processes cannot read or write that file until a previous lock has been removed.
- As with Windows, file locking can only be used if *all* processes accessing the file implement file locking. If one script locks a file, but another chooses to ignore this lock, then the benefits of the lock are lost.
- If the **Preventread** mode is specified with the **FLock** command, all processes which try to lock the file for reading must also wait until the lock is released.
- If the **Preventwrite** mode is specified with the **FLock** command, all other processes which try to lock the file for writing must wait until the current process has released the lock. However, other processes can read the file.
- If the **Nonblock** mode is specified, the script must check system variable

- @FILE\_ERRNO to determine if the lock was successful or unsuccessful. See [FILE\\_ERRNO](#) for the File Access Error Codes.
- It is not possible to lock portions of a file. The entire file must be locked.
- All locks on files are released automatically when the file is closed.
- If the call to **Flock** is executed and another process is busy writing to the file, the command will wait until the lock is released by the other process. For example, assume that there is a file which all ISL scripts need to read. There is also a procedure inside the ISL script, which every so often, needs to update the file (to add new records, for example).
- Locks should be placed on files for only short periods of time. Keeping a file locked for a long time prevents other processes from accessing the file.

### Example 1

The following script shows how to lock a file for reading only:

```
event inq : 1

    var fn : N5
    fopen fn, "/micros/simphony/etc/custlist.dat", read
    flock fn, preventwrite
    call read_from_file( fn )
    funlock fn
    fclose fn
endevent
```

### Example 2

The following script shows how to lock a file for reading and writing:

```
event inq : 2

    var fn : N5
    fopen fn, "/micros/simphony/etc/custlist.dat", append
    flock fn, preventwrite and preventread
    call write_to_file( fn )
    funlock fn
    fclose fn
endevent
```

The call to **Flock** will wait until all files are done reading.

### Example 3

The following script gives an example of the incorrect way of using the Flock command; the file is locked while the script waits for input from the user:

```
event inq : 3

    var fn : N5, data : A20
    fopen fn, "/micros/simphony/etc/custlist.dat", append
    flock fn, preventwrite and preventread

    input data, "Enter customer id"

    call write_to_file( fn, data )
    funlock fn
    fclose fn
endevent
```

---

## Example 4

The proper way to implement the script in example 3 would be:

```
event inq : 1

    var fn : N5, data : A20
    input data, "Enter customer ID#"
    fopen fn, "/micros/simphony/etc/custlist.dat", append
    flock fn, preventwrite and preventread
    call write_to_file( fn, data )
    funlock fn
    fclose fn
endevent
```

## See Also

**FClose**, **FOpen**, and **FUnLock** commands

## FOpen

### Description

This command opens a file for reading or writing.

### Syntax

**FOpen** *file\_number*, *file\_name*, [**Append**] [**And**] [**Read**] [**And**] [**Write**], [**Local**], [**Unicode**]

**Table 59 FOpen Command Arguments**

Argument	Description
<i>file_number</i>	An integer variable which will be assigned a file number to identify the file.
<i>file_name</i>	A string which identifies the file to be opened.
<b>Append</b>	A mode separator that appends to an open file.
<b>And</b>	Required by syntax if more than one mode separator is issued.
<b>Read</b>	A mode separator that reads from an open file.
<b>Write</b>	A mode separator that writes to an open file.
<b>Local</b>	A mode separator that indicates the file is located on the local client workstation (available in SAR only).
<b>Unicode</b>	A mode separator that identifies the file as Unicode (available in SAR only).

### Remarks

- The variable *file\_number* will be assigned a value of 0 if the operation was unsuccessful. This could occur if the file was opened for reading and did not exist, or the permissions of the file were not set correctly.
- The variable *file\_name* must use Windows naming conventions and pathnames. If a file is written to, and does not exist, the file will be created.

- 
- The system variable @FILE\_ERRNUM will contain the operating system error code corresponding to the error which occurred when **FOpen** was executed.
  - The Unicode keyword can be used with, without, before, or after the Local keyword. If used without, do not include an extra comma separator where the Local keyword would have been.

### Example 1

The following statements would open a file and read it:

```
var fn : N5 //open a file for reading
fopen fn, "/micros/symphony/data/emplist.dat", read
```

### Example 2

The following statement would open a file and append to it:

```
var fn : N5 //open a file for appending
fopen fn, "/micros/symphony/log/transact.log", append
```

### Example 3

The following statement would open a file and write to it:

```
var fn : N5 //create a file for writing
fopen fn, "/micros/symphony/log/ws.log", write
```

### Example 4

The following statement would open a file then read and write to it:

```
var fn : N5 //open a file for reading and writing
fopen fn, "/micros/symphony/data/emplist.dat", read and write
endevent
```

### Example 5

The following script will open a file. If the open was unsuccessful, an error message will display the cause of the error.

```
event inq : 1
  var fn : N5
  fopen fn, "myfile.dat", read
  if fn = 0
    errormessage @FILE_ERRSTR
    exitcontinue
  endif
endevent
```

### See Also

**FClose** command

### For...EndFor

#### Description

These commands are used to implement an iterative loop. The **EndFor** command should always be used to terminate the loop.

---

## Syntax

**For** counter = *start\_expression* **To** *end\_expression* [**Step** increment]

.  
. .  
.

## EndFor

**Table 60 For...EndFor Command Arguments**

Argument	Description
<i>counter</i>	A variable that is incremented by the <b>For</b> command.
<i>start_expression</i>	The first variable in the <i>counter</i> ; separated from counter by = sign; it can be one of the following: <ul style="list-style-type: none"><li>• <i>user_variable</i></li><li>• <i>system_variable</i> (N or \$ format)</li><li>• <i>constant</i></li><li>• <i>function</i></li></ul>
<b>...=...To ...[Step...]</b>	Required by syntax.
<i>end_expression</i>	The last variable in the <i>counter</i> ; separated from the start expression by the reserved word <b>To</b> ; it can be one of the following: <ul style="list-style-type: none"><li>• <i>user_variable</i></li><li>• <i>system_variable</i> (N or \$ format)</li><li>• <i>constant</i></li><li>• <i>function</i></li></ul>
<i>increment</i>	Used with the reserved word <b>Step</b> to increase or decrease the value of the <i>counter</i> ; use a negative value to decrease the counter.

## Remarks

- Normally, the variable in the **For** loop will be incremented by one. If required, the Step feature may be used to override this so that the variable may be incremented or decremented by any integer value.
- For loops work similar to C and Basic; the **For** loop counter will always increment to the *end\_expression* + 1. A **For** loop will execute when the following conditions are met:

If **Step** > 0 and counter <= *end\_expression*

If **Step** < 0 and counter >= *end\_expression*

Sample **For** commands:

```
for i = 1 to 10          // execute 10 times
for i = 1 to 10 step 5 // execute 2 times (i=1,6)
```

---

```
for i = 1 to 10 step -5 // will not execute for i = 10 to 1// will not execute
for i = 10 to 1 step -1 // execute 10 times
for i = 10 to 1 step -5 // execute 2 times (i=10,5)
```

## Example

The following script will display the current occupant(s) of a room:

```
event rxmsg : display_occupants
  var row_cnt : n3, room_num : a4, number_occupants : n3, occupant_list[8] : a30
  rxmsg room_num, number_occupants, occupant_list
  if number_occupants > 14
    number_occupants = 14
  endif
  window number_occupants, 38
  for row_cnt = 1 to number_occupants
    display row_cnt, 2, occupant_list[row_cnt]
  endfor
  waitforclear
endevent

//For example, this subroutine will reverse a string
// using the Step feature
sub reverse_string
  var cnt : n3, char : a1, reversed_string : a78
  window 2, len(string_2_reverse) + 2
  display 1, 2, string_2_reverse
  for cnt = len(string_2_reverse) to 1 step -1
    char = mid(string_2_reverse, cnt, 1)
    format reversed_string as reversed_string, char
  display 2, 2, reversed_string
  endfor
endsub
```

## See Also

**Break** and **Forever** commands

## Forever...EndFor

### Description

The **Forever** command provides continuous looping capabilities in a script. The **Forever** command is generally used when the conditions for terminating the loop are too complex for a **For** command, or may not be known ahead of time. This loop may be broken by executing a **Break** command or by exiting the script (for example, **ExitCancel** or **ExitContinue**).

### Syntax

**Forever**

```
.
.
.
```

**EndFor**

### Example

The following script will wait for a magnetic card swipe:

```
event inq : 1
```

```

var mag_card_track2_data : a79

window 1, 28                                // build the window

forever                                    // loop until the user swipes a
                                           // card or presses clear
displaymsinput 1, 0, mag_card_track2_data{m2, 1, 4, *}, " "
display 1, 2, "Please swipe your ID card."
windowinput
if @MAGSTATUS = "Y"                          // we got a swipe
    windowclose                               // close the window
    break                                     // and exit the loop endif
    errormessage "Swipe card or press clear twice"
endfor
endevent

```

## See Also

**Break**, **ExitCancel**, **ExitContinue**, and **Return** commands

## Format

### Description

This command is used to concatenate expressions into a string variable.

### Syntax

**Format** *string\_variable* [, *field\_sep\_char*] **As** *expression* [{*output\_specifier*}],  
*expression* [{*output\_specifier*}] [, *expression* [{*output\_specifier*}],...]

**Table 61 Format Command Arguments**

Argument	Description
<i>string_variable</i>	A place holder for text characters such as a <i>user_variable</i> ( <i>string</i> ).
<i>field_sep_char</i>	The character used to separate fields; use the <b>Chr</b> function to define the character required
<b>As</b>	Required by syntax.
<i>expression</i>	An <i>expression</i> to be concatenated; it may be one of the following: <ul style="list-style-type: none"> <li>• <i>user_variable</i></li> <li>• <i>system_variable</i></li> <li>• constant</li> <li>• string</li> <li>• function</li> <li>• equation</li> </ul>
{ <i>output_specifier</i> }	One or more of the <i>output_specifiers</i> that determine the format of the output fields; see full definition on pages 8-3 through 8-6.

---

## Remarks

- If the field separator character is specified, then the first character in the string is used to separate variables within the string.

```
format string as 1, 2, 3           // will create '123'  
format string, "," as 1, 2, 3     // will create '1,2,3'
```

- The **Format** command is also used to print information to guest checks, receipts, and credit card vouchers. Two events: Print\_Header and Print\_Trailer (see page 8-38) are used to support this function.

## Example

The following script will construct a string\_variable containing the current date in the form dd-mm-yy:

```
event inq : 1  
  var date : a9  
  
  call get_date_string  
endevent  
  sub get_date_string  
  var month_arr[12] : a3  
  
                                     //Listing of all the months  
  
  month_arr[1] = "JAN"  
  month_arr[2] = "FEB"  
  month_arr[3] = "MAR"  
  month_arr[4] = "APR"  
  month_arr[5] = "MAY"  
  month_arr[6] = "JUN"  
  month_arr[7] = "JUL"  
  month_arr[8] = "AUG"  
  month_arr[9] = "SEP"  
  month_arr[10] = "OCT"  
  month_arr[11] = "NOV"  
  month_arr[12] = "DEC"  
  format date as @DAY, "-", month_arr[@MONTH], "-", @YEAR  
                                     // i.e., 10-NOV-93  
endsub
```

## See Also

**FormatQ** and **Split** commands

## FormatBuffer

### Description

This command will format a string containing non-printable characters into a string that is printable.

### Syntax

**FormatBuffer** *source\_string, destination\_string*

**Table 62 FormatBuffer Command Arguments**

Argument	Description
<i>source_string</i>	A <i>string_variable</i> containing non-printable characters.
<i>destination_string</i>	A place holder for the <i>string_variable</i> containing the printable characters.

**Remarks**

- All printable characters will display as-is. All non-printable characters will be formatted as a two-digit hexadecimal number surrounded by angle brackets.
- This function is generally used to look at data from the PMS.

**Example**

The following script will convert a string containing a non-printable character into a string that can be displayed:

```
event inq : 1
  var source_s : A30, dest_s : A30

  format source_s as "before ", chr( 27 ), " after"
  formatbuffer source_s, dest_s
  waitforclear dest_s //displays `before <1B> after`
endevent
```

**See Also**

Format and FormatQ commands

**FormatQ**

**Description**

This command is used to concatenate variables into a string. String variables are automatically surrounded by quotes. This feature can be used to create comma-separated lines in ASCII files.

**Syntax**

**FormatQ** *string\_variable* [, *field\_sep\_char*] **As** *expression*[*{output\_specifier}*], *expression*[*{output\_specifier}*]... [, *expression*[*{output\_specifier}*],...]

**Table 63 FormatQ Command Arguments**

Argument	Description
<i>string_variable</i>	A place holder for text characters such as a <i>User variable (string)</i> .
<i>field_sep_char</i>	The character used to separate fields; use the <b>Chr</b> function to define the character required.
<b>As</b>	Required by syntax.

Argument	Description
<i>expression</i>	An <i>expression</i> to be concatenated; it may be one of the following: <ul style="list-style-type: none"> <li>• user_variable</li> <li>• system_variable</li> <li>• constant</li> <li>• string</li> <li>• function</li> <li>• equation</li> </ul>
{ <i>output_specifier</i> }	One or more of the <i>output_specifiers</i> that determine the format of the output fields; see the full definition on pages 8-3 through 8-6.

### Remarks

- If the field separator character is specified, then the first character in the string is used to separate variables within the string.
- The **FormatQ** command operates in the same way as the **Format** command, except that all strings are automatically quoted. This command is generally used to format lines to a file.

### See Also

**Format** and **Split** commands

## FPutFile

### Description

This command puts a file from the SIM file service:

### Syntax

**FPutFile** *RemoteFileName, LocalFileName, Status*

**Table 64 FPutFile Command Arguments**

Argument	Description
<i>RemoteFileName</i>	Relative to “simdatafiles” directory in \micros\simphony\egatewayservice
<i>LocalFileName</i>	Relative to the location of sarops.exe (...\posclient\bin) directory on the workstation.

---

<b>Argument</b>	<b>Description</b>
<i>Status</i>	Will contain the result of the operation after completion. A status of "0" (zero) indicates the file retrieval was successful. A status of any non-zero value indicates the file retrieval failed.

### **Remarks**

All files are automatically closed at the end of a script.

### **See Also**

FGetFile command

### **FRead**

#### **Description**

This command reads formatted data from a file.

#### **Syntax**

**FRead** *file\_number, user\_variable or list\_spec[, user\_variable \ or list\_spec...]*

---

**Table 65 FRead Command Arguments**

<b>Argument</b>	<b>Description</b>
<i>file_number</i>	Identifies the file to be read; an integer variable which was assigned in the <b>fopen</b> statement when the file was opened
<i>user_variable</i> <i>list_spec</i> is defined as:	A <i>user_variable</i> which will be assigned the data from the file
<i>number_records</i>	A <i>user_variable</i> (integer) containing the number of records to be built from this <i>string</i>
<i>field_array[:field_array]</i>	An <i>array_variable</i> that will hold one field per record; a field can be split into more than one <i>array</i> by separating the <i>array_variables</i> using a colon (:)

### Remarks

- The file must have been opened in **Read** mode in order to execute this command.
- If the System Variable @STRICTARGS is set to 1, then ISL will ensure that the variable count in the **FRead** command line matches the number of fields in the file record. If an incorrect number of fields is specified in the statement or the file is corrupted, then an error message will be generated.
- It is possible to skip over fields in a line by not specifying the variables. For example the third field in the line below would be ignored:

```
fread file_number, variable1, variable2, , variable4
```

If a script needs to read only the first few fields in a file, but wishes to ignore the rest of the fields, then it should specify a \* in the statement to indicate that no more variables should be assigned to that line. For example, if each line in a file has 20 fields, but only the first three need to be read, the following line will only read the first three. All fields are assigned in the order they occur. The \* must be the last element on the **FRead** line.

```
fread file_number, variable1, variable2, variable3, *
```

This command will assign data to the variables a line at a time. If the line in the file has 10 variables and only 7 variables are specified, then the last 3 are thrown away. They are not read on the next **FRead**.

### Example

If a file contains this line:

```
145, "Tooher", "Dan"
```

An ISL script uses the following lines to read the file:

```
event inq : 1
```

```
var num:N5, last_name:A20, first_name:A20
```

```

fread file_number, num, last_name, first_name

//num will be 145
//last_name will be "Tooher"
//first_name will be "Dan"
Endevent

```

## See Also

**FClose**, **FOpen**, **FReadBfr**, and **FReadLn** commands

## FReadBfr

### Description

This command reads a block of data from a file.

### Syntax

**FReadBfr** *file\_number, data, count\_to\_read, count\_read*

**Table 66 FReadBr Command Arguments**

Argument	Description
<i>file_number</i>	Identifies the file to be read; an integer variable which was assigned in the <b>fopen</b> statement when the file was opened.
<i>data</i>	<i>string_variable</i> the <i>data</i> block will read into
<i>count_to_read</i>	How much data to read.
<i>count_read</i>	How much data was actually read?

### Remarks

- The file must have been opened in read mode in order to execute this command.
- This command will read data across lines. This command is equivalent to a raw read from a file.

### Example

The following script will attempt to read 100 characters:

```

event inq : 1

var fn : n5
var data:A100, linesread:N5

fopen fn, "/micros/symphony/etc/script.isl", linesread
freadbfr fn, data, 100, linesread
if linesread <> 100
    errormessage "Tried to read 100 and read ", linesread
    exitcancel
endif
endevent

```

## See Also

**FClose**, **FOpen**, **FRead**, and **FReadLn** commands

---

## FReadLn

### Description

This command reads a line of data from a file.

### Syntax

**FReadLn** *file\_number, line*

**Table 67 FReadLn Command Arguments**

Argument	Description
<i>file_number</i>	Identifies the file to be read; an integer variable which was assigned in the <b>fopen</b> statement when the file was opened
<i>line</i>	String variable where the line will read into

### Remarks

- The file must have been opened in **Read** mode in order to execute this command.
- This command may be useful if the file being **Read** does not store its data in comma-separated format. For example, the Windows system variable, %PATH%, stores its data separated by the (;) character. A script could read the variable and use the **Split** command to access the individual path components.

### Example

The following statements would search for a certain line in the /etc/passwd directory:

```
fopen fn, "/etc/passwd", read
while not feof( fn )
    freadln fn, line
    split line, ":", name,, user_id, group_id, *
endwhile
fclose fn
```

### See Also

**FClose**, **FOpen**, **FRead**, and **FReadBfr** commands

## FSeek

### Description

This command goes to a specified position in the file.

### Syntax

**FSeek** *file\_number, seek\_position*

**Table 68 FSeek Command Arguments**

<b>Argument</b>	<b>Description</b>
<i>file_number</i>	An integer variable which was assigned in the <b>Fopen</b> statement when the file was opened.
<i>seek_position</i>	Where to position the file pointer (specify the offset of the byte the programmer wants to position to).

**Remarks**

- Whenever a file is opened, the file pointer is positioned at the start of the file. When data (a line or number of characters) is read or written, the file pointer is positioned at the end of the data that was read or written. The **FSeek** command allows the user to position the file pointer to an arbitrary point in the file so that the next read or write statement will act on the data or position following the new location of the file pointer.
- If a seek position of -1 is specified, the file pointer will be positioned to the end of the file.

**Example**

The following example gets a number from user, then uses **FReadLn** to read the first field from each line, testing it against the number the user entered. Once the number is found using **FSeek**, the file pointer is positioned at the beginning of the line where the number was found. Then the entire line is read and the first 77 characters displayed for the user.

```

event inq : 1
  var fn : n3
  var fname : a30 = "/micros/simphony/sql.out"
  var line : a200
  var objnum : n6
  fopen fn, fname, read //Open the file
  forever
    input objnum, "Enter number to search for" //Get number to search
    // for from user
    fseek fn, 1 // move file pointer
    // to beginning of file
    call find_obj( fn, objnum ) //Call the subroutine
    if objnum = 0 // if 0, no match was
    // found, break out
      break
    endif
    freadln fn, line //Read the line where
    // match found
    window 1, 78 //Open window
    display 1, 2, mid( line, 1, 77 ) //Display the line
    waitforclear
    windowclose //Close the window
  endfor
endevent

sub find_obj( ref fn, ref objnum )
  var current_position : n6
  var found_num : n6
  prompt "Searching, please wait..."

```

```

while not feof( fn )                                //Loop until end of
                                                    //file encountered
current_position = ftell( fn )                      //Get the current file
                                                    // pointer position
fread fn, found_num, *                              //Fread the first field
                                                    // only from the file
if found_num = objnum                               //If it matches
                                                    //what user entered
    fseek fn, current_position                     //Fseek to the beginning
                                                    // of the line
    return                                         //Exit the subroutine
endif
endwhile
errormessage "Can't find that number"              //If end of file is
                                                    // encountered then
objnum = 0                                          // we didn't find a
                                                    // match, tell user, set
endsub                                             // objnum = 0, and return

```

## See Also

**FClose** and **FOpen** commands

## FUnlock

### Description

This command releases any previous locks on a file.

### Syntax

**FUnlock** *file\_number*

**Table 69 FUnlock Command Arguments**

Argument	Description
<i>file_number</i>	An integer variable which was assigned in the <b>FOpen</b> statement when the file was opened.

### Remarks

Closing a file automatically releases any locks on a file.

### Example

The following example will lock and unlock one file within an Event procedure, while another Event procedure attempts to access it.

```

event inq : 1 var fn : n3
    var fname : a30 = "/micros/simphony/etc/preventread"
    var rite : n5 = 30
    var rote : n5
    var data : a30 = "Some data to write to file"

    fopen fn, fname, read and write
    prompt "Waiting for write access..."
    flock fn, preventread
    fwritebfr fn, data, rite, rote
    waitforclear "File read lock in progress..."
    funlock fn
    waitforclear "File should be unlocked..."
endevent

```

```

event inq : 2 var fn : n3
  var fname : a30 = "/micros/simphony/etc/preventread"
  var reed : n6 = 30
  var red : n6
  var data : a30

  fopen fn, fname, read
  prompt "Waiting for read access..."
  flock fn, preventwrite
  freadbfr fn, data, reed, red
  window 1, 32
  display 1, 2, data
  waitforclear "File write lock in progress..."
endevent

```

## See Also

**FClose**, **FLock**, and **FOpen** commands

## FWrite

### Description

This command writes formatted data to a file.

### Syntax

**FWrite** *file\_number*, *variable1* [, *variable2*][, *variable3*... ]

**Table 70 FWrite Command Arguments**

Argument	Description
<i>file_number</i>	An integer variable which was assigned in the <b>Fopen</b> statement when the file was opened.
<i>variable n</i>	Variables which will be written to the file, where <i>n</i> is the number of variables to write.

### Remarks

- The file must have been opened in Write mode in order to execute this command.
- All strings on the **FWrite** line will be enclosed in quotes.
- This function will write one line of data to the file. The line will be terminated with the standard new line character.

### Example

The following statements will write a single line of data to 3 different lines:

```

fwrite fn, 1, 500, "line 1"
fwrite fn, 2, 501, "line 2"
fwrite fn, 3, 502, "line 3"

```

The above statements will produce the lines below in the data file:

```

1,500,"line 1"
2,501,"line 2"
3,502,"line 3"

```

---

## See Also

**FClose**, **FOpen**, **FWriteBfr**, and **FWriteLn** commands

## FWriteBfr

### Description

This command writes formatted data to a file.

### Syntax

**FWriteBfr** *file\_number, data, count\_to\_write, count\_written*

**Table 71 FWrite Command Arguments**

Argument	Description
<i>file_number</i>	An integer variable which was assigned in the <b>Fopen</b> statement when the file was opened.
<i>data</i>	String variable to write.
<i>count_to_write</i>	How much data to write.
<i>count_written</i>	How much data was actually written?

### Remarks

- The file must have been opened in Write mode in order to execute this command.
- This command will write data across lines.

### Example

This example reads from a file one character at a time, capitalizes the character as long as it is not in a quoted string, and, if the character was changed, writes the new character back to the position in the file where its lowercase counterpart was found.

```
event inq : 1
  var fn : n3 = 1
  var fname : a40 = "/micros/simphony/etc/temp1.dat"
  var ritecnt : n5 = 1
  var rotecnt : n5
  var char : a20 v
  ar fpos : n6 var aschar : n3
  var inquotes : n3
  var changed : n3
  fopen fn, fname, read and write //Open the file for
  // read and write
  //If fn = 0, file
  if fn = 0
  // couldn't be opened
    call ferr(fname)
  endif
  while not feof( fn ) //Loop until the end
  // of file is encountered
    fpos = ftell( fn ) //Store the current
    // file pointer position
    freadbfr fn, char, 1, rotecnt //Read 1 character
    aschar = asc( char ) //Get the ascii number
    // for the character
    if aschar = 34 // if the character
```

---

```

        // is a quotation mark
        if inquotes = 1
            // and if it is a
            // closing quote
            inquotes = 0
            //Set inquotes flag to 0
        else
            // But if it's an opening quote
            inquotes = 1
            //Set inquotes flag to 1
        endif
    endif
    if not inquotes
        //If this character
        // is not in quotes
        call capitalize( char, changed )
        //Pass it to the subroutine
    endif
    if changed = 1
        //If the character was changed
        fseek fn, fpos
        //Fseek back to position
        // where we found the character

        fwritebfr fn, char, ritecnt, rotecnt
        // and write the character
        // to the file
        changed = 0
        //Reset the changed flag
    endif
endwhile
fclose fn
endevent

sub ferr( ref fname)
    exitwitherror "Can't open file ", fname endsub

sub capitalize( ref achar, ref changed )
    //We could also use the
    // UpperCase command
    // but we'll take the
    // slow difficult route for fun

    var aschar : n3 = asc( achar )

    if aschar > 96 and aschar < 123
        //If the character
        // is a lower case alpha
        // get its upper case
        aschar = aschar - 32

        achar = chr( aschar )
        changed = 1
        // and set the changed flag
    endif
endsub

```

## See Also

**FClose**, **FOpen**, **FWrite**, and **FWriteLn** commands

## FWriteLn

### Description

This command writes a line of data to a file.

### Syntax

**FWriteLn** *file\_number*, *line*

---

**Table 72 FWriteLn Command Arguments**

Argument	Description
<i>file_number</i>	An integer variable which was assigned in the <b>Fopen</b> statement when the file was opened.
<i>line</i>	A string variable to write to the file.

**Remarks**

- The file must have been opened in Write mode in order to execute this command.
- No quotes will be removed from the string that is written.

**See Also**

**FClose**, **FOpen**, **FWrite**, and **FWriteBfr** commands

**GetEnterOrClear**

**Description**

This command waits for the operator to press the [Enter] key or the [Clear] key and reports which key was pressed.

**Syntax**

**GetEnterOrClear** *input\_variable*, *prompt\_expression* \ [*output\_specifier*][  
*prompt\_expression*[*output\_specifier*]...]

**Table 73 GetEnterOrClear Command Arguments**

Argument	Description
<i>input_variable</i>	An <i>user_variable</i> that accepts user input
<i>prompt_expression</i>	An <i>expression</i> displayed on the prompt line, usually to instruct the user what to enter; it may be one of the following: <ul style="list-style-type: none"><li>• <i>user_variable</i></li><li>• <i>system_variable</i></li><li>• <i>constant</i></li><li>• <i>string</i></li><li>• <i>function</i></li><li>• <i>equation</i></li></ul>
{ <i>output_specifier</i> }	One or more of the <i>output_specifiers</i> that determine the format of the output fields; see full definition on pages 8-3 through 8-6.

---

## Remarks

- A value of 0 or 1 is placed in the *input\_variable*, depending upon which key is pressed; 0 is placed in the variable if the [Clear] key is used and 1 if the [Enter] key is used.
- The combined length of all *prompt\_expressions* must not exceed 38 characters (including spaces); extra characters will be truncated.
- The *prompt\_expression* is required.

## Example

The following script will wait for either the [Enter] key or the [Clear] key:

```
event inq : 1
  var ent_or_clr : n1
  var ENTER : n1 = 1

  getenterorclear ent_or_clr, "Press ENTER to Inquire, CLEAR to end"
  if ent_or_clr = ENTER
    txmsg "inquiry_1"
  waitforrxmsg
  else
    exitcontinue
  endif
endevent
```

## GetRxMsg

### Description

This command is used to immediately wait for a PMS message.

### Syntax

GetRxMsg prompt

### Remarks

- WaitForRxMsg uses the SIM event structure to process sending and responding to PMS messages. GetRxMsg waits for the response inline.

## Example

This sample code displays the dialog for 3 seconds, changing the text 3 times.

```
event inq:1
  txmsg parm1, parm2, parm4
  getrxmsg "Waiting for response"
endevent
```

## See Also

WaitForRxMsg

## GetTime

### Description

This command reads the current time atomically, allowing the script to read all of the time and date value, which guarantees that the values will be correct.

---

## Syntax

`GetTime [year], [month], [day], \ [hour], [minute], [second], \ [day_of_week], [day_of_year]`

## Remarks

- Each variable on the command line corresponds to the time value to read.
- It is not necessary to include each value in the command.

## Example 1

```
getttime year, month, day// Get only the date
```

## Example 2

```
getttime , , , hour, minute, second// Get only the time
```

## Example 3

```
getttime year, month, day, hour, minute, second// Get everything  
but last two
```

## If...Else[If]...EndIf

### Description

These commands allow conditional execution. The **If** command may be used to compare one expression to another. The **Else** command is used to execute a group of commands when the **If** command's condition is not met. The **ElseIf** command can be used to execute commands when the **If** command's condition is not met and another condition needs to be tested.

### Syntax

`If expression [operator expression][And | Or expression operator \ expression...]`

.  
. .  
. .

**Else**

or

`ElseIf expression [operator expression][And | Or expression \ operator expression...]`

.  
. .  
. .

**EndIf**

**Table 74 If...Else[If]...EndIf Command Arguments**

Argument	Description
<i>expression</i>	One of the following: <ul style="list-style-type: none"> <li>• <i>user_variable</i></li> <li>• <i>system_variable</i></li> <li>• <i>constant</i></li> <li>• <i>string</i></li> <li>• <i>function</i></li> <li>• <i>equation</i></li> </ul>
<i>operator</i>	Can be one or more Relational Operator.
<b>And   Or</b>	Relational Operators used to provide additional or alternative conditions.

**Remarks**

- Numeric, currency, alphanumeric, and key variables may be compared. For example, the following usages are valid:
 

```
if counter < 20
if name = "Richard"
if keyname > @KEY_CLEAR
```
- The *expression* will always be evaluated as true or false; for example, anything that evaluates to 0 is false and anything that evaluates to non-0 (including a negative) is true. If the operator and second expression are left off, the remaining *expression* will still be evaluated in this way.

```
if counter //This will be true as long
//as the counter is not 0
```

- See [ISL System Variables](#).
- It is not considered a fatal error if an **Else** command appears without an If command preceding it. An error will occur if a corresponding **EndIf** command is not found.
- The text "Then" is allowed after an If or **ElseIf** statement, but it is not required. Although this syntax is legal, it conveys no additional meaning to the If or ElseIf statement in which it used. Example:

```
If i < 4 then //Correct
.
.
.
ElseIf i > 10 then //Correct
.
.
.
```

**Example**

The following script will wait for a number entry between 1 and 10:

```

event inq : 9
  var key_pressed : key          //Hold the function key user presses
  var data : a10                //Hold the number user chooses

  forever
    inputkey key_pressed, data, "Number then Enter, Clear to Exit "

    if key_pressed = @KEY_CLEAR
      exitcontinue
    elseif key_pressed = @KEY_CANCEL
      exitcontinue
    elseif key_pressed = @KEY_ENTER
      if data > 0 and data <= 10
        waitforclear "You chose" , data, ". Press clear. "
      else
        errormessage "Choose a number between 1" , \ "
          and 10, then press enter"
      endif
    endif
  endfor
endevent

```

## See Also

**For**, **ForEver**, and **While** commands

## Input

### Description

This command accepts an entry from the operator.

### Syntax

**Input** *input\_variable*[[*input/output\_specifier*]], *prompt\_expression* \ [[*input/output\_specifier*]],  
*prompt\_expression*]

**Table 75 Input Command Arguments**

Argument	Description
<i>input_variable</i>	A <i>user_variable</i> that will store the user's input.
<i>{input/output_specifier}</i>	One or more of the <i>input</i> and <i>output_specifiers</i> that determine the format of all input and output fields; see full definition on pages <a href="#">8-3</a> through <a href="#">8-6</a> .
<i>prompt_expression</i>	An <i>expression</i> displayed on the prompt line, usually to instruct the user what to enter; it may be one of the following: <ul style="list-style-type: none"> <li>• <i>user_variable</i></li> <li>• <i>system_variable</i></li> <li>• <i>constant</i></li> <li>• <i>string</i></li> <li>• <i>function</i></li> <li>• <i>equation</i></li> </ul>

---

## Remarks

- Prior to changing the *input\_variable*, the user's entry will be validated against the field type and optional format definition.
- The combined length of all *prompt\_expressions* must not exceed 38 characters (including spaces); extra characters will be truncated.
- The *prompt\_expression* is required.
- Magnetic card entry input formats are allowed with the **Input** command.
- If the [Clear] key is pressed during execution of the **Input** command, the script will terminate unsuccessfully. This can have undesired side effects. If a script transacts a successful posting and then uses the Input command to get reference information on the posting from the user, the [Clear] key will perform an implicit **ExitCancel**, even though the posting was successful. The following code ensures that the script will not terminate while data is being entered:

```
var user_entry : A20, key_press : key
forever
  inputkey keypress, user_entry, "Enter ref info"
  if keypress = @KEY_ENTER
    break
  //only terminate if ENTER pressed
endif
endfor
```

## Example

The following script accepts a patron number from the user, then transmits it to the PMS for further action:

```
event inq : 1
  var ptrn_no : a8

  input ptrn_no, "Enter Patron Number"           //Get patron number
  txmsg "Inquire_1", ptrn_no                     //Send to PMS
  waitforrxmsg                                   //Wait for reply
endevent
```

## See Also

**InputKey** command

## InputKey

### Description

This command accepts an alphanumeric entry from the operator, then stores the entry and the terminating key stroke in separate variables.

### Syntax

```
InputKey key_variable, input_variable, prompt_expression \
{input/output_specifier}, prompt_expression [{input \
/output_specifier}]...
```

**Table 76 InputKey Command Arguments**

<b>Argument</b>	<b>Description</b>
<i>key_variable</i>	A <i>user_variable</i> key type
<i>input_variable</i>	A <i>user_variable</i> that will store the user's input
{ <i>input/output_specifier</i> }	One or more of the <i>input</i> and <i>output_specifiers</i> that determine the format of all input and output fields; see full definition on pages on pages 8-3 through 8-6.
<i>prompt_expression</i>	An <i>expression</i> displayed on the prompt line, usually to instruct the user what to enter; it may be one of the following: <ul style="list-style-type: none"> <li>• <i>user_variable</i></li> <li>• <i>system_variable</i></li> <li>• <i>constant</i></li> <li>• <i>string</i></li> <li>• <i>function</i></li> <li>• <i>equation</i></li> </ul>

**Remarks**

- The *key\_variable* will be set equal to the terminating key press. In this way, the script can compare the value held by *key\_variable* to the @KEY... System Variables, to test for the terminating keystroke the user pressed. See "ISL System Variables" on page 6-1 for more information about the @KEY... System Variables.
- The *prompt\_expression* is required.

**Example**

The following script waits for a number entry between 1 and 9 followed by the [Enter] key. If the [Clear] or [Cancel] key is pressed, it exits the script:

```

event inq : 9
  var key_pressed : key           //Hold the function key user presses
  var data : a10                 //Hold the number user chooses
  forever
    inputkey key_pressed, data, "Number then Enter, Clear to Exit "

    if key_pressed = @KEY_CLEAR
      exitcontinue
    elseif key_pressed = @KEY_CANCEL
      exitcontinue
    elseif key_pressed = @KEY_ENTER
      if data > 0 AND data <= 10
        waitforclear "You chose ", data, ". Press clear. "
      else
        errormessage "Choose a number between 1 ", \ "and 10, then press enter"
      endif
    endif
  endfor
endevent

```

---

## See Also

Input command

## InfoMessage

### Description

This command will display an informational message and continue.

### Syntax

**InfoMessage** *expression* [{*output\_specifier*}], *expression* \  
[{*output\_specifier*}]...

**Table 77 InfoMessage Command Arguments**

Argument	Description
<i>expression</i>	An <i>expression</i> to be displayed; it may be one of the following: <ul style="list-style-type: none"><li>• <i>user_variable</i></li><li>• <i>system_variable</i></li><li>• <i>constant</i></li><li>• <i>string</i></li><li>• <i>function</i></li><li>• <i>equation</i></li></ul>
{ <i>output_specifier</i> }	One or more of the <i>output_specifiers</i> that determine the format of the output fields; see full definition on pages <a href="#">8-3</a> through <a href="#">8-6</a> .

### Remarks

The **InfoMessage** command expects one message line to be displayed. However, the workstation displays two lines. The message line to be displayed is broken up between the two logical lines. If the line is too long to be displayed, it will be truncated.

## See Also

ErrorMessage

## LineFeed

### Description

This command will line feed the selected printer. The number of line feeds is optional.

### Syntax

**LineFeed** [*number\_of\_line\_feeds*]

---

**Table 78 LineFeed Command Arguments**

Argument	Description
<i>number_of_line_feeds</i>	An <i>expression</i> which defines the number of line feeds.

### Remarks

- Prior to the **LineFeed** command, the printer must be activated within the script using the **StartPrint** command. To determine the line feeds required for the printer, refer to the table that defines ISL Printers on page 8-102.
- Printing will not begin until the **EndPrint** command is executed.
- A line feed is automatically executed after the **PrintLine** command is issued.

### Example

```
event inq : 1
  var kitchen_msg[13] : a20
  var sender_name : a20
  var rowcnt : n3
  window 14, 22 //Display the window
  displayinput 1, 2, sender_name, "Enter your name"
  //Accept users name
  for rowcnt = 1 to 13 //Have user input the message
    displayinput rowcnt + 1, 2, kitchen_msg[rowcnt], "Enter kitchen message"
  endfor
  windowedit 1 //Only save or cancel will
  // end input
  startprint @ordr1 //Start the print job at
  // remote printer1

  printline "======"
  printline "Message from ", sender_name
  printline "======"
  for rowcnt = 1 to 13
    if len(kitchen_msg[rowcnt]) > ""
      printline kitchen_msg[rowcnt]
    endif
  endfor
  printline "=====  
===== END MESSAGE ====="
  linefeed 5
endprint
endevent
```

### See Also

**EndPrint**, **Printline**, and **StartPrint** commands

## ListDisplay

### Description

This command is used to display a list (array) variable within a window. This command is useful when displaying the contents of an array variable that contains data received from a PMS, such as a list of names.

### Syntax

**ListDisplay** *row, column, list\_size, array\_variable*

**Table 79 ListDisplay Command Arguments**

<b>Argument</b>	<b>Description</b>
<i>row</i>	The integer <i>expression</i> specifying the screen <i>row</i> within the defined window where the first <i>array_variable</i> entry will be displayed.
<i>column</i>	The integer <i>expression</i> specifying the screen <i>column</i> within the defined window where the first <i>array_variable</i> entry will be displayed.
<i>list_size</i>	The number of <i>array_variable</i> entries to display.
<i>array_variable</i>	The name of the <i>user_variable</i> that holds the matrix of values to be displayed.

**Remarks**

- The **Window** command must precede this command.
- It is acceptable to set *list\_size* equal to 0, but if this is done, nothing will display. If the *list\_size* is less than zero, an error will occur.
- Each entry will be placed on a separate line directly beneath the previous.

**Example**

The following script will display an employee list:

```
event rxmsg : emp_list
  var emp_list_size : n3
  var emp_list_array[14] : a40

  rxmsg emp_list_size, emp_list_array[      ]
  window 14, 42
  listdisplay 1, 2, emp_list_size, emp_list_array
  waitforclear
endevent
```

**See Also**

Window command

**ListInput**

**Description**

This command is used to display a list (array) variable within a window at the workstation, then waits for the operator to select an item from the list.

**Syntax**

**ListInput** *row, column, list\_size, array\_variable, input\_variable, \*  
*prompt\_expression*[*output\_specifier*]

**Table 80 ListInput Command Arguments**

<b>Argument</b>	<b>Description</b>
<i>row</i>	The integer <i>expression</i> specifying the screen <i>row</i> within the defined window where the first <i>array_variable</i> entry will be displayed.
<i>column</i>	The integer <i>expression</i> specifying the screen <i>column</i> within the defined window where the first <i>array_variable</i> entry will be displayed.
<i>list_size</i>	The number of <i>array_variable</i> entries to display.
<i>array_variable</i>	The name of the <i>user_variable</i> that holds the matrix of values to be displayed.
<i>input_variable</i>	An <i>array_variable</i> or <i>user_variable</i> that accepts user input.
<i>prompt_expression</i>	An <i>expression</i> displayed on the prompt line, usually to instruct the user what to enter; it may be one of the following: <ul style="list-style-type: none"><li>• <i>user_variable</i></li><li>• <i>system_variable</i></li><li>• constant</li><li>• string</li><li>• function</li><li>• equation</li></ul>
{ <i>output_specifier</i> }	One or more of the <i>output_specifiers</i> that determine the format of the output fields; see full definition beginning on page 8-6.

**Remarks**

- The **Window** command must precede this command.
- Each list entry is displayed with a selection number starting at 1. The selection numbers 1 to 9 are preceded by a space. Selection numbers are followed by a period, then a space, then the list entry. For this reason, the window drawn must be at least four columns wider than the longest item in the list. Each list entry is placed on a separate line. The user's entry is placed in the *input\_variable* and is validated against the number of items in the list.
- The *prompt\_expression* is required.
- It is acceptable to set *list\_size* equal to 0, but if this is done, nothing will display. If the *list\_size* is less than zero, an error will occur.

---

## Example

The following script receives and displays a list of guests from the PMS, allows the user to choose one from the list, and then transmits the user's choice to the PMS for further processing:

```
event rxmsg : room_inquire
    var rm_guest[14] : a20           //Quest names array
    var rm_num : a6                 //Room number
    var list_size : n3              //Number of array items
    var user_choice : n3            //Quest number user chooses
    rxmsg rm_num, list_size, rm_guest[ ] // receive message from POS

    window list_size, 24, "Guests- Room #", rm_num
    listinput 1, 1, list_size, rm_guest, user_choice, "Choose a guest"

    txmsg "guest inquiry", rm_num, user_choice
                                     //Ask for info from PMS
    waitforrxmsg                       // on guest user chooses
endevent
```

## See Also

Window command

## ListInputEx

### Description

This command is used to display a list and get an operator selection. This command is the same as **ListInput**, but it does not provide a WROW or WCOL variable.

### Syntax

```
ListInputEx row, column, list_size, array_variable, input_variable, \
prompt_expression[output_specifier]
```

### Remarks

- The **Window** command must precede this command.
- Each list entry is displayed with a selection number starting at 1. The selection numbers 1 to 9 are preceded by a space. Selection numbers are followed by a period, then a space, then the list entry. For this reason, the window drawn must be at least four columns wider than the longest item in the list. Each list entry is placed on a separate line. The user's entry is placed in the *input\_variable* and is validated against the number of items in the list.
- The *prompt\_expression* is required.
- It is acceptable to set *list\_size* equal to 0, but if this is done, nothing will display. If the *list\_size* is less than zero, an error will occur.

## Example

The following script receives and displays a list of guests from the PMS, allows the user to choose one from the list, and then transmits the user's choice to the PMS for further processing:

```
event rxmsg : room_inquire
    var rm_guest[14] : a20           //Quest names array
```

```

var rm_num : a6                //Room number
var list_size : n3            //Number of array items
var user_choice : n3          //Quest number user chooses
rxmsg rm_num, list_size, rm_guest[ ] // receive message from POS

window list_size, 24, "Guests- Room #", rm_num
listinputex 1, 1, list_size, rm_guest, user_choice, "Choose a guest"

txmsg "guest inquiry", rm_num, user_choice
//Ask for info from PMS
waitforrxmsg // on guest user chooses
endevent

```

## See Also

**ListInput** and **Window** command

## ListPrint

### Description

This command will print a list on the selected printer.

### Syntax

**ListPrint** *list\_size, array*

**Table 81 List Print Command Arguments**

Argument	Description
<i>list_size</i>	The number of <i>array_variable</i> entries to be printed.
<i>array_variable</i>	The name of the <i>user_variable</i> that holds the matrix of values to be printed.

### Remarks

- The **StartPrint** and **EndPrint** commands are required when using the **ListPrint** command.
- It is acceptable to set *list\_size* equal to 0, but if this is done, nothing will display. If the *list\_size* is less than zero, an error will occur.

### Example

The following script receives a list of directions from the PMS that describes how to get from the property to another location and prints them at the UWS's check printer:

```

event rxmsg : directions

var directions[50] : a35        //Our direction array
var list_size : n3             //Number of array items
rxmsg list_size, directions[ ] //Here's the message from PMS
startprint @CHK                //Print at the check printer
listprint list_size, directions //Print the list
endprint
endevent

```

---

## See Also

**StartPrint** and **EndPrint** commands

## LoadDbKybdMacro

### Description

This command loads a keyboard macro that is pre-defined in the Symphony database. The macro will execute when transaction processing successfully resumes.

There is another keyboard macro command available: **LoadKybdMacro**, which uses a script-defined keyboard macro.

### Syntax

**LoadDbKybdMacro** *numeric\_expression*

**Table 82 LoadDbKybdMacro Command Arguments**

Argument	Description
<i>numeric_expression</i>	An <i>expression</i> that requires a number; it may be one of the following: <ul style="list-style-type: none"><li>• <i>user_variable</i></li><li>• <i>system_variable</i></li><li>• <i>constant</i></li><li>• <i>string</i></li><li>• <i>function</i></li><li>• <i>equation</i></li></ul>

### Remarks

- The macro is referenced by its object number.
- Only integer variables can be used to run a pre-defined macro.
- If more than one **LoadDbKybdMacro** command is used in the same event, only the last command will be used when transaction processing resumes.

### Example

The following script will load a macro from the Symphony database that will add two menu items to a guest check currently open at the workstation:

```
event inq : 1
```

```
    loaddbkybdmacro 1  
endevent
```

### See Also

**LoadKybdMacro** command

---

## LoadKybdMacro

### Description

This command passes keystrokes to the workstation; these keystrokes will be executed when the script event terminates. There are a variety of ways to specify script-defined macros, as listed and described below.

### Syntax

**LoadKybdMacro** *key\_expression*[, *key\_expression*,...]

**Table 83 LoadKybdMacro Command Arguments**

Argument	Description
<i>key_expression</i>	An <i>expression</i> that can be one of the following: <ul style="list-style-type: none"><li>• <i>key_type:key_number</i></li><li>• <i>Key function</i></li></ul>

### Remarks

- For pre-defined database macros, see **LoadDbKybdMacro**.
- A script-defined macro is one that the script writer constructs using key function codes. These key function codes can be represented by any combination of the following methods:
  - Key pairs—A *key\_pair* in Symphony is designated by the *key\_type* and a *key\_number* separated by a colon. For example, the number 1 on the numeric keypad is represented by the *key\_pair* 9 : 1, where 9 (the *key\_type*) represents the Keypad and where 1 (the *key\_number*) represents Numeric 1. Therefore, one way to load 123 and the [Enter] key would be:  
**loadkybdmacro** 9:1, 9:2, 9:3, 9:12
  - The Key function takes as its argument a *key\_pair* separated by a comma and returns a key function code. This comma-separated *key\_pair* could be represented by two comma-separated variables. Key function - The Key function takes as its argument a *key\_pair* separated by a comma and returns a key function code. This comma-separated *key\_pair* could be represented by two comma-separated variables.

For example:

```
var key_type : Key = 9
loadkybdmacro key(key_type, 1), key(key_type, 2), \
key(key_type, 3), 9:12
```

- @KEY... System Variables—System Variables that begin with @KEY... are special key type variables. These keys can be used to test for and represent movement keys and keys like [Enter] and [Clear]. The @KEY... System Variables can also be used in the **LoadKybdMacro** command.

To continue the example:

```
loadkybdmacro 9:1, 9:2, 9:3, @KEY_ENTER
```

- User-defined variables with the type Key—User-defined variables with the type Key can be assigned key function codes using the Key function or with @KEY... System Variables. Another way to load the keyboard macro:

```
var key_1 : Key //Declare variables as
//Key types
var key_2 : Key var key_3 : Key var Enter : Key

key_1 = key(9,1) //Assign them with
//key()function
key_2 = key(9,2) key_3 = key(9,3)
Enter = @KEY_ENTER // and system variable

loadkybdmacro key_1, key_2, key_3, Enter
```

- If more than one **LoadKybdMacro** command is used in the same event, they will be run in order of appearance when transaction processing resumes, as if they were one large macro.
- Macro keys will remain defined during script processing and will execute once a script is complete, not when an event is complete.

### Example

In the following script, there will be three [Enter] keys that will be run once the script completes:

```
event inq:1
  loadkybdmacro @KEY_ENTER //first enter key
  txmsg "inq_1_request"
  waitforrxmsg
endevent

event rxmsg : inq_1_reply
  loadkybdmacro @KEY_ENTER //second enter key
  txmsg "inq_2_request"
  waitforrxmsg
endevent

event rxmsg : inq_2_reply
  loadkybdmacro @KEY_ENTER //third enter key
endevent
```

## LowerCase

### Description

This command is used to convert a string variable to lower-case.

### Syntax

**LowerCase** *string\_variable*

**Table 84 LowerCase Command Arguments**

Argument	Description
<i>string_variable</i>	The string that will be changed; can be any <i>user_variable</i> (string).

### See Also

UpperCase command

---

## MakeAscii

### Description

This command will transfer the data from a *source\_string* into a *destination\_string*, stripping out any non-ASCII or non-printable characters from the *source\_string*.

### Syntax

**MakeAscii** *source\_string*, *destination\_string*

**Table 85 MakeAscii Command Arguments**

Argument	Description
<i>source_string</i>	A <i>string_variable</i> containing both ASCII and non-ASCII characters.
<i>destination_string</i>	A place holder for the <i>string_variable</i> containing only ASCII characters.

### Example

The following script will convert a string containing both ASCII and non- printable characters into a string that contains only ASCII characters:

```
event inq : 1
  var string1 : A20
  var string2 : A20

  format string1 as "ABC", chr(1), "DEF"
  makeascii string1, string2 //string2 will be "ABCDEF"
```

## MakeUnicode

### Description

This command will transfer the data from a *source\_string* into a *destination\_string*, stripping out any non-printable characters from the *source\_string*.

### Syntax

**MakeUnicode** *source\_string*, *destination\_string*

**Table 86 MakeUnicode Command Arguments**

Argument	Description
<i>source_string</i>	A <i>string_variable</i> containing non-printable characters.
<i>destination_string</i>	A place holder for the <i>string_variable</i> Containing only non-printable characters.

### Example

The following script will convert a string containing non-printable characters into a string that contains only printable characters:

```
event inq : 1
  var string1 : A20
  var string2 : A20
```

```
format string1 as " "
makeunicode string1, string2 //string2 will be "MAP"
```

## Remarks

This command is only available on SAR Ops

## Mid

### Description

This command is used to set all or some part of one string variable equal to another string variable.

### Syntax

**Mid** (*string\_variable*, *start*, *length*) = *replacement\_string*

**Table 87 Mid Command Arguments**

Argument	Description
<i>string_variable</i>	The string that will be changed; can be any <i>User_variable</i> (string).
<i>start</i>	The character position within the <i>string_variable</i> , where the <i>replacement_string</i> will begin to overwrite.
<i>length</i>	The number of characters in the <i>string_variable</i> that will be changed using the <i>replacement_string</i> to the right of the equal sign.
=	Required by syntax.
<i>replacement_string</i>	The string containing the characters used for the replacement can be any <i>user_variable</i> (string).

## Remarks

- The parentheses are required.
- The first character in the string is always 1. If the start or length is less the 0, then an error will occur.
- If the start is greater than the *string\_variable* itself, no data will be assigned. If the length is greater than the room left to assign the *string\_variable*, then the data will be truncated.

```
var string : A10
string = "this short"
// In this command, the length exceeds room left.
// Only first 5 letters of ("long string") are used,
// overwriting the last five characters of string.
// In this operation, string would become "this long".

mid( string, 6, 10 ) = "long string"

// In this command, this starting position is greater
// than length of string.
// 0 characters are overwritten.
```

---

```
mid( string, 25, 10 ) = "long string"
```

- Do not confuse this command with the **Mid** function.

### Example

The following script will replace the first three letters of the variable "string" with the string "NEW":

```
event inq : 1

var string: a10 = "OLD STRING"

waitforclear string //Prompt will show "OLD STRING"
mid(string, 1, 3) = "NEW" //Change OLD to NEW
waitforclear string //Prompt will show "NEW STRING"
endevent
```

## MSleep

### Description

This command tells the script to sleep for the requested number of milliseconds.

### Syntax

**MSleep** *milliseconds*

### Example

```
event inq:2

var seconds:N5

input seconds, "Enter number of seconds to sleep" prompt "Sleeping"
msleep seconds*1000

waitforenter "Done waiting ", seconds*1000, " seconds."
endevent
```

## PopUpIsITs

### Description

This command displays a pop-up touchscreen defined by the **SetIsITsKey** command.

### Syntax

**PopUpIsITs**

### Remarks

After a touchscreen has been displayed, its keys remain defined until cleared by the **ClearIsITs** command.

### Example

The subroutine below first clears any previously defined touchscreen keys and displays two touchscreen keys, [YES] and [NO], which are defined by the **SetIsITsKey** command. This subroutine displays these keys using the **PopUpIsITs** command, as the operator is issued a prompt by the system, and captures the operator's input.

```
sub get_yes_or_no( ref answer, var prompt_s:A38 )
var keypress : key
```

```

var data : A20

clearislt
setisltkey 2, 2, 4, 4, 3, @KEY_ENTER, "YES"
setisltkey 2, 6, 4, 4, 3, @KEY_CLEAR, "NO"
popupislt

inputkey keypress, data, prompt_s
  if keypress = @KEY_ENTER
    answer = 1
  else
    answer = 0
  endif
endsub

```

## See Also

ClearIsITs, DisplayIsITs, and SetIsITsKey commands

## PrintLine

### Description

This command prints a line on the selected printer defined in the **StartPrint** command. The print information can be provided as text or by referencing a variable field.

This command may also be used to print Binary Data (used to output information such as barcodes, rotated text, emphasized print, etc.) from within a SIM Script.

### Syntax

**PrintLine** *expression* [{*output\_specifier*}] or *directive* \ [*expression* [{*output\_specifier*}] or *directive*]...

**Table 88 PrintLine Command Arguments**

Argument	Description
<i>expression</i>	An <i>expression</i> that represents the string to be printed: it may one of the following: <ul style="list-style-type: none"> <li>• <i>user_variable</i></li> <li>• <i>system_variable</i></li> <li>• <i>constant</i></li> <li>• <i>string</i></li> <li>• <i>function</i></li> <li>• <i>equation</i></li> </ul>
<i>directive</i>	Specific instructions that affect the color, width, and justification of the printed characters; see full definition on page 6-5.
{ <i>output_specifier</i> }	One or more of the <i>output_specifiers</i> that determine the format of the output fields; see full definition beginning on page 8-6.

---

## Remarks

- This command will affect the printer selected using the **StartPrint** command. For a complete list of available printers, see the table provided in the detail description of the **StartPrint** command.
- If printing was started using the **StartPrint** command, then only the first 32 characters in the **PrintLine** command are significant.
- The **PrintLine** command sends a carriage return/line feed to the printer after every line.
- The **PrintLine** command may be used to format characters to a certain position (for example, left, right, or center justified). See [Using Format Specifiers](#).
- Control characters can be printed on the **PrintLine** using the **Chr** function. For example, one can send a command to print a section of a line in emphasized style. The IBM proportional control code ESC 69 turns emphasized print on, and ESC 70 turns emphasized print off:

```
printline "A line with ", chr(27), chr(69), "emphasized"\
          "print", chr(27), chr(70), " on it."
```

The only control code not printable using the **Chr** function is the ASCII 0 (NUL). To print a NUL, use the following sequence:

```
chr( 16 ), chr( 48 )
```

- For example to output Binary Data, the following script sends 3 lines of text to the printer connected to the PCWS, and will send the proper control codes for turning on emphasized print for the 2nd line. Note the emphasize on/ off codes are on the same line.

```
startprint @chk
  printline "This is a normal line"
  printline chr(27), "E1", "This is emphasized", chr(27), "E0"
  printline "This is back to normal"
endprint
```

- The workstation application will decode the binary data, and pass it through to the printer.
- 'Binary data' or 'control codes' are all ASCII characters below 32 (20 hex). For example, chr(31) is a control code, but chr(32) is not a control code. All characters from 32 to 255 are considered printable characters.
- One exception to the control code format is that ASCII NULs cannot be printed using chr(0). If a chr(0) needs to be printed, then the system variable @nul should be used instead. For example:

```
printline chr(27), "E", @nul, "Normal print"
```

Only 32 printable characters can be sent on one line. However, 48 characters can be placed on the line. Each control character requires 2 characters.

Therefore, only 24 control codes can be placed on one printline (24 x 2 => 48).

However, non-control codes require only one character. Since not all printer commands are all composed of binary data, this limitation should not present a problem.

- When using the SIM Print\_Header or Print\_Trailer commands (see page 8-37, the control codes will also be formatted properly to the printer when SIM provides the data using the @header[] and @trailer[] system variables. Though each line is

---

supposed to have 32 characters of data, up to 48 characters can be formatted. However, the rule that each control code requires two characters is still in effect.

### Example

The following script constructs and prints a date string bordered by hash marks at the workstation's check printer:

```
sub print_date
  var date : a9
  var hash_mark : a24      //Use format to build a date
                          // string
  format date as @DAY, "-", month_arr[@MONTH], "-", @YEAR

  setstring hash_mark, "="
  startprint @CHK        //Print what follows at this UWS
                        // check printer
  printline hash_mark    //Print the date string
  printline @DWON, @REDON, date{=16} // double-wide, in red
  printline hash_mark    // and centered between
                        // hash marks
  endprint
endsub
```

### See Also

**StartPrint** command and the **Chr** function

## PrintSimFeatures

### Description

This command is used to print out all SIM features available in the current SIM engine.

### Syntax

**PrintSimFeatures** printerObjectNumber

### Remarks

- The output will contain all commands, system variables, and functions.

### Example

```
event inq:1
  PrintSimFeatures 3
endevent
```

### Prompt

### Description

This command is used to display an operator prompt on the prompt line at the workstation.

### Syntax

**Prompt** expression[*{output\_specifier}*] [, expression \ *{output\_specifier}*...]

**Table 89 Prompt Command Arguments**

Argument	Description
<i>expression</i>	An <i>expression</i> that represents the prompt for the user: it may one of the following: <ul style="list-style-type: none"> <li>• <i>user_variable</i></li> <li>• <i>system_variable</i></li> <li>• <i>constant</i></li> <li>• <i>string</i></li> <li>• <i>function</i></li> <li>• <i>equation</i></li> </ul>
{ <i>output_specifier</i> }	One or more of the <i>output_specifiers</i> that determine the format of the output fields; see full definition beginning on page 8-6.

**Remarks**

- The combined length of all expressions must not exceed 38 characters (including spaces); extra characters will be truncated.
- The **Prompt** command should only be used when a time-consuming piece of code is to be executed. This command will inform the user that the UWS is busy. All commands that require user input display their own prompts.

```

prompt "Posting unsuccessful"
      // displayed but erased immediately

waitforclear
      // "Press clear to continue" will display

```

**Example**

The following script receives a list of guests from the PMS, calls a subroutine that sorts the list, then calls another that displays the list:

```

event rxmsg : guest_list
  var num_guests : n3
  var guest_list[100] : a20

  rxmsg num_guests, guest_list[ ]      //Get the guest array from PMS

  prompt "Sorting guest list - please wait..."//Tell the user
  call sort_list                       //Call routine that sorts the list

  call display_guests                 //Call routine that displays the list
endevent

```

**ProRate**

**Description**

This command is used to indicate to the system that prorated itemizers are to be used. Prorated itemizers are required for some Property Management Systems.

---

## Syntax

### ProRate

## Remarks

- If the ProRate command is encountered either inside or outside an Event procedure, all itemizers will be prorated for the duration of the ISL script. The following system variables are prorated:  
@SI[]  
@DSC  
@SVC  
@AUTOSVC  
@TAX[]  
Refer to [ISL System Variables](#) for more information.
- Prorated itemizers are useful if the PMS is posting sales, discounts, tax, etc. during the charge posting operation. When prorated totals are used, the totals reflect the Current Payment's share of a guest check. If the Current Payment is voided, the totals will have the reversed polarity to reflect this. The only exception (for example, the total that is not prorated) is a charged tip, which will always be completely attributed to its associated payment. This mode is supported by Symphony.

The following equations can be used by the PMS PC to determine the Current Payment Total of the prorated transaction being posted:

Current Payment Total = + (+) Sales 1 Total

+ (+) Sales 2 Total

+ (+) Sales 3 Total

+ (+) Sales 4 Total

+ (+) Sales 5 Total

+ (+) Sales 6 Total

+ (+) Sales 7 Total

+ (+) Sales 8 Total

+ (+) Sales 9 Total

+ (+) Sales 10 Total

+ (+) Sales 11 Total

+ (+) Sales 12 Total

+ (+) Sales 13 Total

+ (+) Sales 14 Total

+ (+) Sales 15 Total

+ (+) Sales 16 Total

+ (-) Discount Total

+ (+) Service Charge Total (kybd)

+ (+) Service Charge Total (auto)

- 
- + (+) Tax 1 Total (if non-VAT)
  - + (+) Tax 2 Total (if non-VAT)
  - + (+) Tax 3 Total (if non-VAT)
  - + (+) Tax 4 Total (if non-VAT)
  - + (+) Tax 5 Total (if non-VAT)
  - + (+) Tax 6 Total (if non-VAT)
  - + (+) Tax 7 Total (if non-VAT)
  - + (+) Tax 8 Total (if non-VAT)

The Previous Payment Total is also provided.

In some jurisdictions, the prorated calculations will result in inexact tax totals. This occurs because of rounding errors associated with proration and the methods required to compute tax. As an example, consider three guests paying a \$10.00 check which includes \$1.00 tax. The first two guests will be charged

\$0.33 tax and the third \$0.34 tax (the rounding adjustment is included in the last total).

These situations are unavoidable; if complete accuracy is required, a Split Check operation should be performed and the remaining checks (after the Split Check) should be individually posted to the PMS.

#### **Notes:**

- If Value Added Tax (VAT) is used, the tax totals represent the total sales amounts (inclusive of VAT) for each of the VAT tax types and must not be included in the Transaction Total or Current Payment Total equations.
- In non-prorated mode, if the Current Payment Amount field in the message data block is less than the computed Transaction Total (above), then a partial amount has been tendered.
- If U.S. inclusive tax is used, the tax total associated with this rate will be zero.

## **[Retain/Discard]GlobalVar**

### **Description**

These commands instruct the ISL to save all global variable values in between transactions, or to discard them.

### **Syntax**

**RetainGlobalVar** or **DiscardGlobalVar**

### **Remarks**

- These commands are global, which means they remain in effect until the alternative command is used or until the script file has been changed (for example, until the script file is opened for edit and closed).
- The default action is to discard the global variable values after each event.

### **Example**

The following example could be used to count the number of times Tender #1 has been used. This value will be retained and incremented until the script is changed.

```

retainglobalvar

    var numtnd : n5                                //Numtnd is retained until POS
                                                    // Operations is Shut Down or
                                                    // Reloaded.

    event tmed : 1

    numtnd = numtnd + 1
        .
        .
        .
endevent

```

## Return

### Description

This command is used to return from a subroutine procedure prior to reaching the end of the routine (**EndSub**). It is provided as a means of breaking out of the subroutine under certain conditions.

### Syntax

Return

### Remarks

The Return command is not allowed in an Event procedure.

### Example

The following example shows a subroutine that takes as arguments the file number of an open file and a search number. It tests the first field in each line for a number that matches the search number. If a match is found, the subroutine **Returns** without executing the rest of the commands in the subroutine. If no match is found before the end of file is encountered, the subroutine exits normally.

```

sub finfd_obj( ref fn, ref search_num )
    var current_position : n6
    var found_num : n6
    prompt "Searching, please wait..."
    while not feof( fn )                                //Loop until end
                                                        // of file encountered
        current_position = ftell( fn )                 //Get the current
                                                        // file pointer position
        fread fn, found_num, *                          //Fread the first field
                                                        // only from the file
        if found_num = search_num                       // if it matches
                                                        // what user entered
            fseek fn, current_position                 //Fseek to the beginning
                                                        // of the line
            return                                     // exit the subroutine
        endif
    endwhile
    errormessage "Can't find that number"              //If end of file
                                                        // is encountered then
    search_num = 0                                     // we didn't find a
                                                        // match, tell user, set
    endsub                                             // search_num = 0,
                                                        // and return

```

---

## See Also

If, Sub, and While commands

## ReTxMsg

### Description

This command retransmits a message. When used in place of the **TxMsg** command, the retransmit flag is set to “R” and the sequence number is not incremented.

### Syntax

ReTxMsg

### Remarks

This command should only be used with the UseISLTimeOuts command.

## See Also

UseISLTimeOuts command

## RxMsg

### Description

This command defines the format of the data segment of an interface response message by specifying a variable name for each piece of data it receives. The **RxMsg** command will assign the values in the Applications Data Segment of the variables specified in the **RxMsg** statement.

### Syntax

**RxMsg** *user\_variable* or *list\_spec*, *user\_variable* or *list\_spec*...] or **RxMsg** \_Timeout

Table 90 RxMsg Command Arguments

Argument	Description
<i>user_variable</i>	A <i>user_variable</i> which will be assigned data.
<i>list_spec</i> is defined as: <i>number_records</i>	A user integer <i>variable</i> containing the number of records to be built from this <i>string</i> .
<i>field_array</i> [: <i>field_array</i> ]	An <i>array_variable</i> that will hold one field per record; field can be split into more than one <i>array</i> by separating the <i>array_variables</i> using a colon (:).

### Remarks

- The Event **RxMsg** command is executed when a response is received from the interfaced system. The Event must contain an **RxMsg** command. The first field in a response message is always the Event ID and should not be declared using this command. The **RxMsg** command defines all the fields (and their order) following the Event ID field. The interface message fields are always separated

---

by an ASCII field separator character (ASCII 1CH). The variable fields must have been previously declared using the **Var** command.

- The *user\_variable* can be up to 255 characters in length and must begin with a letter A - Z, a - z, or the underscore character (\_). It may include any character in the range A - Z, 0 - 9, and the underscore character.
- If the System Variable @STRICTARGS is set to 1, then ISL will ensure that the variable count in the **RxMsg** command matches the number of fields in the file record. If an incorrect number of fields is specified in the statement or the file is corrupted, an error message will be generated.
- This Event requires that both the **TxMsg** and **WaitForRxMsg** commands be used in another event in the script for the **RxMsg** command to work.
- If the **UseISLTimeOuts** command is used and the PMS does not respond to an ISL message within the timeout period, the ISL will search the script for an **RxMsg** event with an Event ID of \_Timeout. If \_Timeout is found, ISL will bypass the standard Symphony error messaging and process a user-defined ISL instruction in its place.
- If the **RxMsg** command specifies more variables than are present in the applications data segment, no error will occur. The extraneous variables on the command will retain their previous value. If the number of fields in the Applications Data Segment exceeds the number of variables in the **RxMsg** command, no error will occur. The command will execute successfully and the extraneous data in the message will be thrown away.
- It is not possible to execute an **RxMsg** if no message has been received. It is also not possible to execute multiple **RxMsg** commands within one **RxMsg** Event. Once the first **RxMsg** command executes, any subsequent **RxMsg** command will cause an error.
- This command is related to the Split command. While the Split command works with any string buffer and any field separator, the **RxMsg** command assumes the PMS message and the ASCII field separator character.

### Example

```
event inq : 1
  var room_num : a4
  input room_num, "Enter Room Number"
  waitforrxmsg
  txmsg @CKEMP,@CKNUM,@TNDTTL,room_num
endevent
event rxmsg : charge_declined
  var room_num : a4
  rxmsg room_num
  exitwitherror "Charge for room ", room_num," declined"
endevent
```

### See Also

**Event, Split, TxMsg, UseISLTimeOuts, Var, and WaitForRxMsg** commands

---

## SaveChkInfo

### Description

This command saves a type of check detail known as check information detail lines in the Guest Check files.

### Syntax

**SaveChkInfo** *expression*[[*output\_specifier*]][, *expression* \ [*output\_specifier*]]...

**Table 91 SaveChkInfo Command Arguments**

Argument	Description
<i>expression</i>	An <i>expression</i> that represents the information to be saved; it may be one of the following: <ul style="list-style-type: none"><li>• <i>user_variable</i></li><li>• <i>system_variable</i></li><li>• <i>constant</i></li><li>• <i>string</i></li><li>• <i>function</i></li><li>• <i>equation</i></li></ul>
{ <i>output_specifier</i> }	One or more of the <i>output_specifiers</i> that determine the format of the output fields; see full definition beginning on page 8-6.

### Remarks

- Like other types of guest check detail, such as totals and definitions, guest check information detail lines are only stored in the Guest Check files (stored in workstations) temporarily and cleared upon closing a guest check. As a consequence, this detail only has short-term value unless it is also written to a third-party database or to Closed Check files.
- **Closed Check Files:** Once stored in these files, guest check information detail can be exported to an ASCII comma-separated file using the Symphony Data Access Service or check detail can be written to a file using the ISL file I/O operations. Then, an external program can be created to extract this information from these files and manipulate the information for a variety of purposes.
- **Third-party System:** If this information is captured by a third-party system, like a delivery system, accessing the information depends on the resources of that particular system.
- The **SaveChkInfo** command is issued once for each line of check information detail written to the check. The process goes like this:
  - The first occurrence of **SaveChkInfo** in an event writes to the first check information detail line.
  - Each **subsequent** call to **SaveChkInfo** writes to the next check information detail line.

- 
- Check information detail is not actually written to the check detail until the script terminates.
  - Check information detail can be overwritten by using **SaveChkInfo** in another event.

## How to Capture and Print Check Information Detail

### Introduction

Both SIM and Symphony must be used in the following ways to accomplish these tasks:

- A SIM script must be designed to collect and save the check information detail, and
- Specific Symphony programming must be enabled to print and display the check information detail to the specifications of the establishment.

### Designing the SIM Script

The SIM must be used to capture and save check information detail. That is, the script must be designed so that an operator can input check information detail and save it, if necessary, from the System Unit.

When designing the script, keep the following rules in mind:

- **Rule:** Do not issue **SaveChkInfo** in a single event more times than the number of allocated check information detail lines; doing so will result in an error.
- **Rule:** Only 24 characters per check information detail line may be written with **SaveChkInfo**.

The following steps are the sequence of events that the script might execute in order to capture and save check information detail:

1. Begin a check.
2. Draw a window.
3. Prompt the operator to enter name and address information.
4. Issue the **SaveChkInfo** command to save the input data.

### Programming the Symphony Database

Whether check information detail lines print and where they print on guest checks and remote output is determined by specific Symphony database programming, not the script. In order to print this detail and save it in the Guest Check file:

- Check information detail lines must be allocated in Symphony
- Programmed to print

For example, one can program the Symphony to print the check information detail captured above or after the guest check header, or after the guest check trailer. In the example of the delivery system, the restaurant programmed the check information detail lines to print before the guest check header.

---

## Operational Considerations

### Voiding Check Information Detail

Unlike other types of check detail, check information detail cannot be voided from a check using any Symphony void procedures or modified using the Edit Closed Check function.

### Example

The ISL event below initiates a procedure for collecting and saving the following customer information for a fictional delivery system at a restaurant: last and first name, telephone number, street address, and up to four lines for directions.

```
event inq : 1
  var field_name[8] : a24
  var customer_info[8] : a24
  field_name[1] = "Last: "
  field_name[2] = "First: "
  field_name[3] = "Phone: "
  field_name[4] = "Addr: "
  field_name[5] = "D1: "
  field_name[6] = "D2: "
  field_name[7] = "D3: "
  field_name[8] = "D4: "
  var rowcnt : n3

window 8, 40
touchscreen 13
for rowcnt = 1 to 8
  display rowcnt, 2, field_name[rowcnt]
  displayinput rowcnt, 10, customer_info[rowcnt],\
  "Enter ", field_name[rowcnt]
endfor
windowedit
for rowcnt = 1 to 8
  savechkinfo customer_info[rowcnt]
endfor
waitforclear
windowclose
touchscreen 3
endevent
```

### See Also

**ClearChkInfo** command

## SaveRefInfo

### Description

This command is used to save the contents of an expression as part of tender reference information.

### Syntax

**SaveRefInfo** *expression*[[*output\_specifier*]][, *expression* \ [*output\_specifier*]]...

**Table 92 SaveRefInfo Command Arguments**

<b>Argument</b>	<b>Description</b>
<i>expression</i>	An <i>expression</i> that represents the information to be saved; it may be one of the following: <ul style="list-style-type: none"> <li>• <i>user_variable</i></li> <li>• <i>system_variable</i></li> <li>• <i>constant</i></li> <li>• <i>string</i></li> <li>• <i>function</i></li> <li>• <i>equation</i></li> </ul>
{ <i>output_specifier</i> }	One or more of the <i>output_specifiers</i> that determine the format of the output fields; see full definition beginning on page 8-6.

**Remarks**

- The **SaveRefInfo** command will only work with the **Event Tmed** procedure.
- Every time this command is used, a new reference line is created.
- Up to eight references may be saved with each tender and each may be up to 19 characters long. Text or fields greater than 19 characters will be truncated.

**Example**

The following script allows a user to enter delivery information on a To Go check:

```

event tmed : 10
  var rowcnt : n3
  var deliv_desc[6] : a15
  var deliv_info[6] : a20
  var cnt : n3
  deliv_desc[1] = "Name:"
  deliv_desc[2] = "Company:"
  deliv_desc[3] = "Address 1:"
  deliv_desc[4] = "Address 2:"
  deliv_desc[5] = "City:"
  deliv_desc[6] = "Phone:"

  //Display a window with address
  // prompts, and accept delivery
  // info from user

  window 6, 43
  for rowcnt = 1 to 6
    display rowcnt, 2, deliv_desc[rowcnt]
    displayinput rowcnt, 13, deliv_info[rowcnt], "Enter ", deliv_desc[rowcnt]
  endfor
  windoweditwithsave //Input can only be terminated
                    // by cancel or save

  saverefinfo "DELIVER TO:" //Save this line to check detail
  for cnt = 1 to 6 //If user made an entry on a
                  // line, save
                  // the entry to check detail

    if len(deliv_info[cnt]) > 0 AND deliv_info[cnt] <> " "
      saverefinfo deliv_info[cnt]
    endif

```

```
    endfor
  endevent
```

## See Also

Event and **SaveRefInfo** commands

## SaveRefInfo

### Description

This command is used to save both the type and the contents of an expression as part of tender reference information. **SaveRefInfo** requires the reference type as an argument so that different types of reference detail can be distinguished if exported later.

### Syntax

**SaveRefInfo** *ref\_type*, *expression*[*output\_specifier*][, *expression* \ [*output\_specifier*]]...

**Table 93 SaveRefInfo Command Arguments**

Argument	Description
<i>ref_type</i>	A type N3 integer that represents the reference type; specify 0-255; 0 denotes no reference type, as with <b>SaveRefInfo</b> .
<i>expression</i>	An <i>expression</i> that represents the information to be saved; it may be one of the following: <ul style="list-style-type: none"><li>• <i>user_variable</i></li><li>• <i>system_variable</i></li><li>• <i>constant</i></li><li>• <i>string</i></li><li>• <i>function</i></li><li>• <i>equation</i></li></ul>
<i>{output_specifier}</i>	One or more of the <i>output_specifiers</i> that determine the format of the output fields; see full definition beginning on page 8-6.

### Remarks

- The **SaveRefInfo** command will only work with the **Event Tmed** procedure.
- Every time this command is used, a new reference line is created.
- Up to eight references may be saved with each tender and each may be up to 19 characters long. Text or fields greater than 19 characters will be truncated.

### Example

The following script allows a user to enter delivery information on a To Go check:

```
event tmed : 10
  var rowcnt : n3
  var deliv_desc[6] : a15
  var deliv_info[6] : a20
  var cnt : n3
```

```

deliv_desc[1] = "Name:"
deliv_desc[2] = "Company:"
deliv_desc[3] = "Address 1:"
deliv_desc[4] = "Address 2:"
deliv_desc[5] = "City:"
deliv_desc[6] = "Phone:"

//Display a window with address
// prompts, and accept delivery
// info from user

window 6, 43
for rowcnt = 1 to 6
    display rowcnt, 2, deliv_desc[rowcnt]
    displayinput rowcnt, 13, deliv_info[rowcnt], "Enter ",
deliv_desc[rowcnt]
endfor
windoweditwithsave //Input can only be terminated
// by cancel or save

saverefinfo 15, "DELIVER TO:" //Save this line to check detail for cnt = 1
to 6 //If user made an entry on a
// line, save
// the entry to check detail

    if len(deliv_info[cnt]) > 0 AND deliv_info[cnt] <> " "
        saverefinfo 15, deliv_info[cnt]
    endif
endfor
endevent

```

## See Also

Event and **SaveRefInfo** commands

## SetIsITsKey

### Description

This command defines a key to be displayed on a touchscreen, allowing one to define a key that normally would be programmed in the Touchscreens module.

### Syntax

**SetIsITsKey** *row, col, num\_rows, num\_cols, font, \key\_expression, expression*

**Table 94 SetIsTSKey Argument**

Argument	Description
<i>row</i>	Integer expression defining row coordinate of key (1-6).
<i>col</i>	Integer expression defining column coordinate of key (1-10).
<i>num_rows</i>	Integer expression defining the key height in rows (1-6).
<i>num_cols</i>	Integer expression defining the key width in columns (1-10).

Argument	Description
<i>font</i>	Font size integer expression (1-3).
<i>key_expression</i>	Key value to be returned when this key is pressed; it may be one of the following: <b>Key function</b> <i>user_variable</i> (type Key only) <i>system_variable</i> (@KEYS only)
<i>expression</i>	Descriptor to appear on the key as it is displayed; it may be one of the following: <ul style="list-style-type: none"> <li>• <i>user_variable</i></li> <li>• <i>system_variable</i></li> <li>• <i>constant</i></li> <li>• <i>string</i></li> <li>• <i>function</i></li> <li>• <i>equation</i></li> </ul>

### Remarks

- Up to nine keys may be defined with the **SetIsITsKey**.
- Any previously defined touchscreen keys are automatically cleared each time a script executes. However, if two or more touchscreens are defined within an event, the **ClearIsITs** command must be used to clear the touchscreen keys.

### Example

The subroutine below first clears any previously defined touchscreen keys and displays two touchscreen keys, [YES] and [NO], which are defined by the **SetIsITsKey** command. This subroutine displays these keys as the operator is issued a prompt by the system and captures the operator's input.

```
sub get_yes_or_no( ref answer, var prompt_s:A38 )
  var keypress : key
  var data : A20

  clearislts
  setisltskey 2, 2, 4, 4, 3, @KEY_ENTER, "YES"
  setisltskey 2, 6, 4, 4, 3, @KEY_CLEAR, "NO"
  displayislts

  inputkey keypress, data, prompt_s
  if keypress = @KEY_ENTER
    answer = 1
  else
    answer = 0
  endif
endsub
```

### See Also

**ClearIsITs**, **DisplayIsITs**, and **PopUpIsITs** commands

---

## SetReRead

### Description

This command allows OPS to re-read the ISL script for new or changed ISL scripts.

### Syntax

SetReRead

### Remarks

- Previously, OPS would always check if an ISL script had changed before processing the event. Now that many more events have been added, continuously checking file status would be an unnecessary strain on system resources, especially since this feature is used only for debugging scripts.
- The ISL script will also be reread if /micros/symphony/etc/isl.reread is present when POS Operations is started.

## SetSignOn[Left/Right]

### Description

These commands determine where ISL places the minus sign when formatting numbers.

### Syntax

SetSignOnLeft or SetSignOnRight

### Remarks

- This is a global command.
- By default, ISL puts the minus sign to the right of the number being displayed (for example, -45 will display as "45-"). If this is not acceptable, then executing the **SetSignOnLeft** command will cause ISL to format all numbers with the minus sign on the left.

REMEMBER: Using the **SetSignOnRight** or **SetSignOnLeft** command does NOT change the way ISL reads input data. Any external data read and interpreted by ISL, such as received messages, file read operations, and operator input, must have the negative sign on the left-hand side of the value.

For example, if the ISL script prompted for an amount entry, and the operator entered 1.23-, the value would not be accepted as positive. Any negative PMS entries must have the sign on the left side of the field.

### Example

```
event inq : 1

    waitforclear -123           //will display '123-' by default
    setsignonleft
    waitforclear -123           //will display '-123'
    setsignonright
    waitforclear -123           //will display '123-'
endevent
```



---

## Split

### Description

This command is used to split a field-separated string into separate variables.

### Syntax

**Split** *string\_to\_split*, *field\_sep\_char*, *user\_variable* or *list\_spec* \ [, *user\_variable* or *list\_spec*...]

**Table 96 Split Command Argument**

Argument	Description
<i>string_to_split</i>	The field-separated <i>string</i> to split.
<i>field_sep_char</i>	The character used to the separate fields in the <i>string_to_split</i> ; use the <b>Chr</b> function to define the character required.
<i>user_variable</i>	A <i>user_variable</i> which will be assigned one of the individual fields from the <i>string_to_split</i> .
<i>list_spec</i> is defined as: <i>number_records</i>	A user integer variable containing the number of records to be built from the <i>string_to_split</i> .
<i>field_array[:field_array]</i>	An <i>array_variable</i> that will hold one field per record; a field can be split into more than one <i>array</i> by separating the <i>array_variables</i> using a colon (:).

### Remarks

If the system variable @STRICTARGS is set to 1, ISL will ensure that the variable count in the **Split** command matches the number of fields in the file record. If an incorrect number of fields is specified in the statement or the file is corrupted, an error message will be generated.

### Example

The following example will assume the PMS has sent the guest name and room number as one field. The name is separated by the room number with the [fs] character. Without the Split command, the script would have to search through the field one character at a time until the [fs] character was found. The Split command, however, will automatically split the data into fields:

```
event rxmsg : guest
  var name_and_room : a25
  var name : a20
  var room_number : n5

                                //Get the data as one field, and
                                //split it into 2 fields
  name_and_room, "[fs]", name, room_number
                                //Display data in window

window 5, 30, "Guest Inquiry"
display 2, @CENTER, name
```

---

```
display 4, @CENTER, room_number
waitforclear
endevent
```

## See Also

Format and **SplitQ** commands; **Chr** function

## SplitQ

### Description

This command is used to split a field-separated string into separate variables and strips the quotes from the quoted string.

### Syntax

**SplitQ** *string\_to\_split*, *field\_sep\_char*, *user\_variable* or *list\_spec* \ [, *user\_variable* or *list\_spec*...]

**Table 97 SplitQ Command Arguments**

Argument	Description
<i>string_to_split</i>	The field-separated <i>string</i> to split.
<i>field_sep_char</i>	The character used to the separate fields in the <i>string_to_split</i> ; use the <b>Chr</b> function to define the character required.
<i>user_variable</i>	A <i>user_variable</i> which will be assigned one of the individual fields from the <i>string_to_split</i> .
<i>list_spec</i> is defined as: <i>number_records</i>	A user integer variable containing the number of records to be built from the <i>string_to_split</i> .
<i>field_array</i> [: <i>field_array</i> ]	An <i>array_variable</i> that will hold one field per record; a field can be split into more than one <i>array</i> by separating the <i>array_variables</i> using a colon (:).

### Remarks

- The **SplitQ** command operates in the same way as the **Split** command, except that it will strip quotes from quoted strings. The **SplitQ** command is generally used to split lines from a file, where strings are usually quoted.
- If the system variable @STRICTARGS is set to 1, ISL will ensure that the variable count in the **SplitQ** command matches the number of fields in the file record. If an incorrect number of fields is specified in the statement or the file is corrupted, an error message will be generated.

## See Also

Format and **Split** commands; **Chr** function

---

## StartPrint...EndPrint[FF/NOFF]

### Description

These commands are used to start and end a print session on any POS printer (as opposed to a line printer). The **StartPrint** command is used to select the printer and start the print session and the **EndPrint** command ends the print session. The Form Feed [FF] and No Form Feed [NOFF] may also be used with the **EndPrint** command, depending on the needs of the application and printer default.

### Syntax

**StartPrint** *printer\_name* | *expression* [, *backup\_dten* [, *reference\_line*]]

.  
. .  
. . .

**EndPrint** [or *EndPrintFF* or *EndPrintNOFF*]

**Table 98 StartPrint...EndPrint[FF/NOFF] Command Arguments**

Argument	Description
<i>printer_name</i>	The object number of the printer.
<i>expression</i>	Any <i>variable</i> that contains the object number of a printer in the system.
<i>backup_dten</i>	The object number for the backup printer that overrides the backup printer programmed in the database.
<i>reference_line</i>	The text string to be displayed in the printer error window if an error occurs during.

### Remarks

- The expression is defined using one of the ISL Printer system variables in the following table:

**Table 99 ISL Printer System Variables for StartPrint...EndPrint[FF/NOFF]**

ISLPriter Name	Printer Assignme nt in Workstati ons Printers	Valid Printer Types	# of char SW	# of char DW	Red	FF Default	Extended Print
@RCPT	Customer Receipt	Roll	32	16	Optional	Yes	Yes
@CHK	Guest	Roll	32	16	Optional	Yes	Yes

ISLPriter Name	Printer Assignme nt in Workstati ons Printers	Valid Printer Types	# of char SW	# of char DW	Red	FF Default	Extended Print
@ORDR# (where # is 1 - 15 referring to the appropriate order device)	Order (local or remote)	Roll	32	16	Optional	Yes	Yes
		KDS	19	No	No	No	No
@VALD	Validation	Roll	32	16	Optional	Yes	Yes

- The physical printer is selected based on the workstation printer assignments in the Symphony database. For example, when @CHK is selected, the ISL will pass along the information to the Check Printer defined for the workstation, from which the Event was initiated.
- In the case where a printer fails and a backup printer is programmed, the printing session will notify the operator at the workstation that the printing session has failed and the print session has been sent to the backup printer.
- Printing will not begin until the **EndPrint** command is executed. Each printer will **FormFeed** or not, depending on its default characteristic (see table); **EndPrint** will follow the printer's default. Use either **EndPrintFF** or **EndPrintNOFF** to force the opposite action.
- If single-wide printing is used, anything over 32 characters will be truncated. If the @DWON Print Directive is used, anything over 16 characters will be truncated.
- If the @REDON Print Directive is used with the @KDS device, the output will be Bright. If the @REDON Print Directive is used with a printer, the correct type of ribbon is required (black/red) for output to print in red.
- Note that only one print session may be active at any one time from the same workstation.

## POS Setup

To enable the printer, enter the Symphony database and verify that the printer:

- Is entered as a device in the Workstations module
- Has its object number entered as one of the printers in the *Workstations* module

## Example

The following script allows a user to enter a 13 line message and print it at the kitchen printer:

```
event inq : 1

var kitchen_msg[13] : a20
var sender_name : a20
var rowcnt : n3
```

```

var hash_mark : a24
window 14, 22                                //Display the window

displayinput 1, 2, sender_name, "Enter your name"
                                                //Accept users name
                                                //Have user input the message

for rowcnt = 1 to 13
    displayinput rowcnt + 1, 2, kitchen_msg[rowcnt], "Enter kitchen message"
endfor
windowedit                                    //Only save or cancel will

setstring hash_mark, "="                    //end input
startprint @ordr1                            //Start the print job at
                                                // remote printer1

printline hash_mark
    printline "Message from ", sender_name
    printline hash_mark
    for rowcnt = 1 to 13
        if len(kitchen_msg[rowcnt]) > ""
            printline kitchen_msg[rowcnt]
        endif
    endfor
    printline "=====END MESSAGE====="
endprint
endevent

```

### See Also

- **PrintLine** command
- "ISL Printing"

## Sub... EndSub

### Description

These commands are used to declare the start and end of a subroutine. A subroutine may be used by an event or another subroutine by using the Call command.

### Syntax

**Sub** *name* [( **Ref** | **Var** *parameter* [, **Ref** | **Var** *parameter*]...)]

.  
.  
.

EndSub

**Table 100 Sub...EndSub Command Arguments**

Argument	Description
<i>name</i>	The subroutine name
<b>Ref</b>	ISL keyword
<b>Var</b>	Var command, see page <a href="#">8-112</a> .

Argument	Description
<i>parameter</i>	<p>A <i>variable</i> or <i>expression</i> passed from the associated <b>Call</b> command; it may be one of the following:</p> <ul style="list-style-type: none"> <li>• <i>variable</i> by reference</li> <li>• <i>array</i> by reference <i>expression</i> by value, i.e.,</li> <li>• <code>local_variable_name : [A, \$, N ]</code></li> </ul>

### Remarks

- Each **Sub** command defines the number and type of parameters that can be passed in. If the **Call** command has the incorrect number of arguments or the incorrect type of arguments, an error will display.
- **Sub** commands are not allowed within an event.

```

event inq : 1
sub                               // will display error
.
.
.
endsub endevent

```
- Each subroutine has access to the calling event's variables, all global variables, and may declare their own local variables.
- The name may be any length up to 255 characters and must begin with a letter A - Z, a - z, or the underscore character (\_). It may include any character in the range A - Z, 0 - 9, and the underscore character.

### Using Subroutines

ISL subroutines can be passed parameters in the same way as C, BASIC, or Pascal subroutines. Data can be passed in by two methods: value or reference.

#### By Value

- A parameter in a **Sub** command is considered to be by value if declared as a normal ISL variable. Example:

```
sub get_name( var target_name:A20, var target_id:N5 )
```

Both `target_name` and `target_id` are local variables which are assigned the value passed in with the **Call** command. A **Call** command to call this subroutine could be:

```
call get_name( "Smith", 145 )
```

Any type of ISL expression can be passed in. For example:

```
call get_name( "Smith", 145 + offset )
call get_name( user_input, elist[ 25 ] )
```

- The expression type (string, numeric,...) can be different from the one declared in the **Sub** command. Example:

```
call get_name( "Smith", "45" )
```
- The assignment of the expression to the subroutine parameter follows the same rules when setting a variable in a normal assignment expression.

- Arrays cannot be passed in by value.
- When a variable is passed in by value (using the **Var** command in the **Sub** statement), a copy is made of the variable and given the name specified in the **Sub** statement. Any change made to a variable passed by value in a subroutine does not affect the original value of the variable.

```

event inq : 1
  var i : n5 = 10           //Set i to 10
  call mysub ( i )         //Pass in i by value
  waitforclear "i = ", i  //i is still equal
                           // to 10
endevent

sub mysub ( var j : n5 )
  j = 20                   //Change local copy,
                           // not the original
endsub

```

### By Reference

- There are two types of data that can be passed in by reference: variables and arrays. To pass either, the **Ref** variable is used in the **Sub** statement. No type information is specified for the referenced variable.

For example, in the following line status is passed by reference, and

```

prompt_string is passed by value.
sub mysub( ref status, var prompt_string:A20 )

```

The following example shows correct and incorrect ways to invoke mysub:

```

var result:N5
  call mysub( result, "Enter data" ) // Correct
  call mysub( result+1, "Enter data" )
                                     // Incorrect: 'result+1' is not a variable.
  call mysub( (result), "Enter data" )
                                     // Incorrect: '(result)' is considered an
                                     // expression

```

- To pass an array, empty brackets must be placed after the array name both in the **Sub** and the **Call** commands. Example:

```

sub mysub( ref data[], var prompt_string:A30 )

```

The following example passes an array to mysub:

```

var array[ 10 ]:A20
  call mysub( array[], "Enter data" ) // Correct
  call mysub( array, "Enter data" )
                                     // Incorrect. Need [] after array

```

- When a variable is passed in by reference, any change in the subroutine to the variable affects the original value of the variable. The name after the **Ref** variable can be thought of as being another name for the variable passed in.

```

event inq : 1
  var i : n5 = 10           //Set i to 10
  call mysub ( i )         //Pass in i by
                           //reference
  waitforclear "i = ", i  //i is now equal
                           //to 20
endevent

sub mysub ( ref j )
  j = 20                   //Change original
                           //value of i and j

```

endsub

### Example

The event below calls a subroutine, `format_data`, that formats the current date as follows:  
`dd-mmm-yyyy`.

```
event inq : 1
var date : all
```

```
    call format_date( date, @day, @month, @year)
    waitforclear date
endevent
```

```
sub format_date( ref date, var day : n5, var month : n5, var year : n5 )
    var month_arr[12] : a3
    month_arr[1] = "JAN"
    month_arr[2] = "FEB"
    month_arr[3] = "MAR"
    month_arr[4] = "APR"
    month_arr[5] = "MAY"
    month_arr[6] = "JUN"
    month_arr[7] = "JUL"
    month_arr[8] = "AUG"
    month_arr[9] = "SEP"
    month_arr[10] = "OCT"
    month_arr[11] = "NOV"
    month_arr[12] = "DEC"
```

```
    format date as day, "-", month_arr[ month ], "-", year
endsub
```

### See Also

Call and Var commands

## TimerSet, TimerReset, TimerResetAll

### Description

This command is used to launch and cancel timer events.

### Syntax

**TimerSet** seconds, eventName

**TimerReset** eventName

**TimerResetAll**

### Remarks

`TimerResetAll` will reset the SIM script's timers, but does not affect other SIM scripts' timers.

### Example

```
event sign_in
    TimerSet 5, "mytimer"
endevent
```

```
event sign_out
    TimerReset "mytimer"
endevent
```

```

event timer : mytimer
    InfoMessage "In mytimer"
endevent

```

## TxMsg

### Description

This command defines the applications data segment of a message that will be transmitted over the interface.

### Syntax

**TxMsg** *expression* [{*output\_specifier*}], [*expression* [{*output\_specifier*}] \...]

**Table 101 TxMsg Command Arguments**

Argument	Description
<i>expression</i>	An <i>expression</i> that will be transmitted over the interface; it may be one of the following: <ul style="list-style-type: none"> <li>• <i>user_variable</i></li> <li>• <i>system_variable</i></li> <li>• <i>constant</i></li> <li>• <i>string</i></li> <li>• <i>function</i></li> <li>• <i>equation</i></li> </ul>
{ <i>output_specifier</i> }	One or more of the <i>output_specifiers</i> that determine the format of the output fields; see full definition beginning on page 8-6 .

### Remarks

- The **TxMsg** command must be followed by the **WaitForRxMsg** command.
- If more than one field is required, multiple expressions must be separated by commas. These commas will be replaced in the message received by the interfaced system by field separator characters (ASCII 1CH).
- A statement may continue over multiple lines by including the line continuation character (\) at the end of each line. The line continuation character is very useful as **TxMsg** commands tend to be very lengthy.

### Example

A transmission message that includes the check employee number, the check number, tendered total, and a declared room number field could be defined as follows:

```

event inq : 1
    var room_num : a4
    input room_num, "Enter Room Number"
    txmsg "charge_inq",@CHKEMP,@CHKNUM,@TNDTTL,room_num
                                                //The first field (charge_inq) is an
                                                // example of an identifying string

```

```

// that the PMS might use to process
// message from the POS.

waitforrxmsg
endevent
  event rxmsg : charge_declined //This is one of the PMS response
                                // possibilities
    var room_num : a4
    rxmsg room_num
    exitwitherror "Charge for room ", room_num," declined"
endevent

```

## See Also

Event, RxMsg, TxMsgOnly, and WaitForRxMsg commands

## TxMsgOnly

### Description

This command sends a message to a PMS without waiting for a response.

### Syntax

**TxMsgOnly** *expression*[[*output\_specifier*]][, *expression*[[*output\_specifier*]] \...]

**Table 102 TxMsgOnly Command Arguments**

Argument	Description
<i>expression</i>	An <i>expression</i> that will be transmitted over the interface; it may be one of the following: <ul style="list-style-type: none"> <li>• <i>user_variable</i></li> <li>• <i>system_variable</i></li> <li>• <i>constant</i></li> <li>• <i>string</i></li> <li>• <i>function</i></li> <li>• <i>equation</i></li> </ul>
{ <i>output_specifier</i> }	One or more of the <i>output_specifiers</i> that determine the format of the output fields; see full definition beginning on page 8-6.

### Example

A transmission message that includes the check employee number, the check number, tendered total, and a declared room number field could be defined as follows:

```

event inq : 1
  var room_num : a4
  input room_num, "Enter Room Number"
  txmsgonly "charge_post", @CHKEMP, @CHKNUM, @TNDTTL, room_num

  //No message will be received. If the PMS responds, it will
  // be ignored.
endevent

```

---

## See Also

TxMsg command

## UpperCase

### Description

This command is used to convert a string variable to uppercase.

### Syntax

UpperCase *string\_variable*

Table 103 UpperCase Command Arguments

Argument	Description
<i>string_variable</i>	The string that will be changed to an uppercase <i>user_variable</i> (string).

## See Also

LowerCase command

## UseBackupTender

### Description

This command instructs the ISL to switch to the programmed backup Tender.

### Syntax

UseBackupTender

### Remarks

- Tender Media PMS Option **Switch to Alternate Tenders** if PMS Timeout must be enabled. If backup tender is not programmed, this command has no effect.
- This is useful for posting to other tenders when the primary PMS is not active.

### Example

```
event rxmsg : _Timeout
    waitforconfirm "Post to backup tender"
    usebackuptender
    exitcontinue
endevent
```

## See Also

Event Tmed command

## Use[Compat/ISL]Format

### Description

These commands are used to instruct ISL to use the ISL message format or the Symphony-standard message format.

---

## Syntax

**UseCompatFormat** or **UseISLFormat**

## Remarks

- These commands are global.
- If the Symphony-standard message format is selected, the Application Data Segment will not contain the two-byte sequence number or the retransmission flag, or the FS after the STX. For more information, see [Message Formats and Interface Methods](#).

## Use[ISL/STD]TimeOuts

### Description

These commands instruct ISL how to process a PMS timeout. **UseISLTimeOuts** will search the script file for an **RxMsg** Event with an Event ID of `_Timeout`. **UseSTDTimeOuts** will use the standard Symphony error messaging for a PMS timeout.

### Syntax

**UseISLTimeOuts** or **UseSTDTimeOuts**

### Remarks

- The Event ID `_Timeout` will bypass the standard Symphony error messaging for a PMS timeout and process instructions from the ISL script file.
- For example, if the **UseISLTimeOuts** command is used and the PMS does not respond to an ISL message within the timeout period, the ISL script may then ask the user if the processing should be cancelled, or if a backup tender should be used.

### See Also

**Event**, **TxMsg**, and **RxMsg** commands

## UseSortedDetail

### Description

This command causes detail system variables to access consolidated detail.

### Syntax

**UseSortedDetail**

### Remarks

This command applies to the detail system variables only.

### Example

The following example, which assumes that check information lines are equal to one, displays the name, tax amount, and quantity for each line of detail. Use this event to see how **UseSortedDetail** changes the detail output format for consolidated menu items.

```
event inq : 1
  var chk_line = 1
  UseSortedDetail
  while chk_line <= @numdttl
```

```

        call display_dtl
        chk_line = chk_line + 1
    endwhile
endevent

sub display_dtl
    window 5,40
    display 2,5, "Menu Item Name      = " , @dtl_name[chk_line]
    display 3,5, "Tax Amount      = " , @dtl_taxttl[chk_line]
    display 4,5, "Quantity = " , @dtl_qty[chk_line] if @detailsorted = 1
    display 5,5 "Detail Is Consolidated" else
    display 5,5 "Detail Is Not Consolidated" endif
    waitforclear
endsub

```

## See Also

UseStdDetail command and @DETAILSORTED system variable

## UseStdDetail

### Description

This command causes the detail system variables to access raw detail.

### Syntax

UseStdDetail

### Remarks

This command applies to the detail system variables only.

## See Also

UseSortedDetail command and @DETAILSORTED system variable

## Var

### Description

This command is used to declare user variables. When it is used outside an event or subroutine, the user variable will be accessible globally. When it is used inside an event or subroutine, the variable is considered "local" and is only allowed to be used by that event or any subroutine called by the event.

### Syntax

Var *user\_variable* : *variable\_specifier*

Table 104 Var Command Argument

Argument	Description
<i>user_variable</i>	A user-defined name for a variable. If an <i>array_variable</i> is being declared, the <i>user_variable</i> must be followed immediately by brackets containing the maximum number of items the <i>array_variable</i> may contain, (for example, name[100]).

Argument	Description
<i>variable_specifier</i>	Made up of a type and a size specifier. The <i>type_specifier</i> can be an N, \$, or A. The size specifier can be either a number (for example, 12) or an integer <i>expression</i> enclosed in parentheses, such as (12 + 15). If the <b>Key</b> <i>type_specifier</i> is used, the size should not be included. The <i>variable_specifier</i> is concatenated together, and defines whether the <i>variable</i> is alphanumeric, numeric (integer), a decimal, a key, and if it's one of the first three, how many characters or digits it contains.

### Example

```
var guest_name : A20
```

```
var guests[max_guests] : A(max_name_length)
```

### Remarks

- The *user\_variable* name can be up to 255 characters in length and must begin with a letter A - Z, a - z, or the underscore character (\_). It may include any character in the range A - Z, 0 - 9, and the underscore character. Case is insignificant and the name must not contain spaces.
- It is possible to declare a variable with a size that is defined by an expression, rather than a hard-coded number. These are known as variable-size variables. If the ISL encounters a left parentheses immediately following the type of the variable, it will assume that an expression follows, which defines the variable's size. Variable-size variables can be declared as follows:

```
var i : n3 = 15
var window_width : n(i + 15)
```

If *i* = 15, then the line shown above would be the same as:

```
var window_width : N30
```

- If the *size* of the *variable* is not known when the variable is being defined, then the variable size may be placed within parentheses.

```
var string : A10
var string : A( 7 + 3 )           //Same as A10
var string : A( num_guests * 2 ) //Depends on value
                                   // num_guests
```

- The *type\_specifier* is different for each of the four types of user-defined variables. Note that no size is specified when declaring a key variable.

**Table 105 Type Specifiers for User-Defined Variables**

Field Type	Type Specifier	Example
Numeric	n or N	n3
Decimal	\$	\$6
Alphanumeric	a or A	a25

---

For more detail about `variable_specifiers`, refer to [Data Types](#). The declaration of a four digit room number would be defined as:

```
var room_num:N4
```

An array with six elements may also be defined as:

```
var message_text[6]:A32
```

More than one variable can be declared on the same line, as long as they are separated by commas:

```
var room_num : a5, guest_count : n3
```

Variables can be declared and defined on the same line:

```
var city_name : a10 = "Charleston"
```

- Zero-length arrays and zero-size variables are allowed.
- All variables are cleared when a new Event is executed, unless the `RetainGlobalVar` command is used (which only affects global variables).

## See Also

[`Retain/Discard`]GlobalVar command

## WaitForClear

### Description

This command requires the operator to press the [Clear] key before proceeding. It is often used after the Display command.

### Syntax

```
WaitForClear [prompt_expression[output_specifier]]\ [,  
prompt_expression[output_specifier]...]
```

**Table 106 WaitForClear Command Arguments**

Argument	Description
<i>prompt_expression</i>	An <i>expression</i> displayed on the prompt line, usually to instruct the user what to enter; it may be one of the following: <ul style="list-style-type: none"><li>• <i>user_variable</i></li><li>• <i>system_variable</i></li><li>• <i>constant</i></li><li>• <i>string</i></li><li>• <i>function</i></li><li>• <i>equation</i></li></ul>
<i>{output_specifier}</i>	One or more of the <i>output_specifiers</i> that determine the format of the output fields; see full definition beginning on page 8-6.

---

## Remarks

- The default prompt, “Press Clear to continue”, will appear on the prompt line of the workstation. This may be overridden by providing a `prompt_expression` with the command.
- The combined length of all `prompt_expressions` must not exceed 38 characters (including spaces); extra characters will be truncated.

## Example

The following script would display some text, then require the operator to press the [Clear] key before continuing:

```
event inq : 1
  window 1, 14
  display 1, 2, "Hello"           //"You say Hello"
  waitforclear
  display 1, 2, "Goodbye"       // "and I say Goodbye"
  waitforclear
endevent
```

## See Also

`Display`, `WaitForConfirm`, `WaitForEnter`, and `b` commands

## WaitForConfirm

### Description

This command requires the operator to press the [Enter] key or the [Clear] key.

### Syntax

**WaitForConfirm** [*prompt\_expression* [{*output\_specifier*}]] \ [,  
*prompt\_expression* [{*output\_specifier*}]...]

**Table 107 WaitForConfirm Command Arguments**

Argument	Description
<i>prompt_expression</i>	An <i>expression</i> displayed on the prompt line, usually to instruct the user what to enter; it may be one of the following: <ul style="list-style-type: none"><li>• <i>user_variable</i></li><li>• <i>system_variable</i></li><li>• <i>constant</i></li><li>• <i>string</i></li><li>• <i>function</i></li><li>• <i>equation</i></li></ul>
{ <i>output_specifier</i> }	One or more of the <i>output_specifiers</i> that determine the format of the output fields; see full definition beginning on page 8-6.

---

## Remarks

- If the operator presses the [Enter] key, the script will continue.
- If the operator presses the [Clear] key, the operation will be cancelled and the script will be exited. The default prompt, "Press [Enter] to continue", will appear on the prompt line of the workstation. This may be overridden by providing a *prompt\_expression* with the command.
- The combined length of all *prompt\_expressions* must not exceed 38 characters (including spaces); extra characters will be truncated.

## Example

The following script is a transmission message that includes the check employee number, the check number, tendered total, and a declared room number field.

After the room\_num is displayed, the script will wait for the [Enter] key or the [Clear] key:

```
event inq : 1
  var room_num : a4
  input room_num, "Enter Room Number"
  waitforconfirm
    txmsg "charge_inq",@CHKEMP,@CHKNUM,@TNDTTL,room_num
    //The first field (charge_inq) is an
    // example of an identifying string
    // that the POS might use to process
    // message from the POS.

    waitforrxmsg
  endevent
event rxmsg : charge_declined //This is one of the PMS response
  // possibilities
  var room_num : a4
  rxmsg room_num
  exitwitherror "Charge for room ", room_num," declined"
endevent
```

## See Also

**Display**, **WaitForClear**, **WaitForEnter**, and **WaitForRxMsg** commands

## WaitForEnter

### Description

This command requires the operator to press the [Enter] key before proceeding.

### Syntax

```
WaitForEnter [prompt_expression[[output_specifier]]] \ [,
prompt_expression[[output_specifier]]...]
```

**Table 108 WaitForEnter Command Arguments**

Argument	Description
<i>prompt_expression</i>	An <i>expression</i> displayed on the prompt line, usually to instruct the user what to enter; it may be one of the following: <ul style="list-style-type: none"><li>• user_variable</li><li>• system_variable</li><li>• constant</li><li>• string</li><li>• function</li><li>• equation</li></ul>
<i>{output_specifier}</i>	One or more of the <i>output_specifiers</i> that determine the format of the output fields; see full definition beginning on page 8-6.

### Remarks

- The default prompt, "Press Enter to continue," will appear on the prompt line of the workstation. This may be overridden by providing a *prompt\_expression* with the command.
- The combined length of all *prompt\_expressions* must not exceed 38 characters (including spaces); extra characters will be truncated.

### Example

The following script would display the guest's name and require the operator to press the [Enter] key before continuing:

```
event rxmsg : guest
  var name : a20
  rxmsg name
  waitforenter "guest is ", name
endevent
```

### See Also

Display, WaitForClear, WaitForConfirm, and WaitForRxMsg commands

## WaitForRxMsg

### Description

This command is used after a message has been transmitted over the interface so that the system waits for a response.

### Syntax

**WaitForRxMsg** [*prompt\_expression* [*{output\_specifier}*]] \ [,  
*prompt\_expression* [*{output\_specifier}*]...]

**Table 109 WaitForRxMsg Command Arguments**

Argument	Description
<i>prompt_expression</i>	An <i>expression</i> displayed on the prompt line, usually to instruct the user what to enter; it may be one of the following: <ul style="list-style-type: none"> <li>• user_variable</li> <li>• system_variable</li> <li>• constant</li> <li>• string</li> <li>• function</li> <li>• equation</li> </ul>
{ <i>output_specifier</i> }	One or more of the <i>output_specifiers</i> that determine the format of the output fields; see full definition beginning on page 8-6.

**Remarks**

- The default prompt, “Please Wait--Sending Message,” will appear on the prompt line of the workstation. The default may be overridden by providing a *prompt\_expression* with the command.
- The **WaitForRxMsg** is not a stand-alone command; the **TxMsg** command must precede the **WaitForRxMsg**. The **WaitForRxMsg** command is an implicit return.
- When a **TxMsg** statement is followed by a **WaitForRxMsg** statement and a response message is received from the interfaced system, it will assume that there is a return event (Event Rxmsg) that corresponds to the message from the interfaced system.

**Example**

A transmission message that includes the employee check number, the check number, tendered total, and a declared room number field could be defined as follows:

```

event inq : 1
    var room : n5
    input room, "Room? " txmsg "room_inq", room
    waitforrxmsg //Script stops here
    waitforclear //Not executed because
                // waitforrxmsg has
endevent // terminated event
    
```

**See Also**

Event RxMsg, RxMsg, TxMsg, WaitForClear, WaitForConfirm, and WaitForEnter commands

**WaitPrompt/ClearWaitPrompt**

**Description**

These commands are used to display a ‘wait prompt’ dialog while SIM is busy processing a lengthy operation.

---

## Syntax

WaitPrompt text

ClearWaitPrompt

## Remarks

- ClearWaitPrompt is called automatically when a script exits.

## Example

This sample code display the dialog for 3 seconds, changing the text 3 times.

```
event inq:1
  var i:n
  for i = 1 to 3
    WaitPrompt "Waiting ", i
    MSleep 1000
  endfor
  ClearWaitPrompt
endevent
```

## While...EndWhile

### Description

The While command is used to implement a loop structure. The **EndWhile** is used to end the loop.

### Syntax

While expression

.  
.  
.

EndWhile

Table 110 While...EndWhile Command Arguments

Argument	Description
<i>expression</i>	The loop condition <i>expression</i> to be evaluated; it may be one of the following: <ul style="list-style-type: none"><li>• <i>user_variable</i></li><li>• <i>system_variable</i></li><li>• <i>constant</i></li><li>• <i>string</i></li><li>• <i>function</i></li><li>• <i>equation</i></li></ul>

### Remarks

- When ISL encounters a **While** statement, it will execute all statements within the While and its corresponding **EndWhile** command until the expression in the

---

**While** command becomes FALSE. If the expression is not initially true, then the statements within the **While** block are not executed.

```
while not feof( fn )
    call process_data( fn )
    .
    .
    .
endwhile
```

The **While** example shown above is the standard method of using the **Feof** function to test for the end of the file being processed.

endsub

- The **While** command can be nested within other **While** commands.
- The expression in the **While** command is similar to the conditional expression within the **If** command.

### Example

```
event inq : 1
    while data_ok = 1
        max_data = 10
    while i < max_data
        call get_next_line
        i = i + 1
    endwhile
    endwhile
endevent
```

### See Also

**For**, **ForEver**, and **If** commands; **Feof** function

## Window

### Description

This command will draw a window on the operator display and is required in order to display information referenced by the various **Display** commands.

### Syntax

**Window** *row*, *column*[, *expression*[{*output\_specifier*}]...]

**Table 111 Window Command Arguments**

Argument	Description
<i>row</i>	The number of rows the window should contain; valid entries are 1 to 14.
<i>column</i>	The number of columns the window should contain; valid entries are 1 to 78.

Argument	Description
<i>expression</i>	An <i>expression</i> that represents the title of the window, which will appear centered in the top line of the window itself (above the first row); it may be on of the following: <ul style="list-style-type: none"> <li>• <code>user_variabe</code></li> <li>• <code>string</code></li> </ul>
<i>{output_specifier}</i>	One or more of the <i>output_specifiers</i> that determine the format of the output fields; see full definition beginning on page 8-6.

### Remarks

- The row and column values in the window are a function of how much the programmer needs to display. Refer to the **Display** commands to determine these requirements.
- The optional window title may be a text string or a combination of *user\_variables* and *string\_variables*.
- The maximum number of characters that will be displayed in the Window title is the number of columns minus 1; extra characters will be truncated.

### Example

The following script will read the information from Track 1 of a credit card and display it in a window:

```

event inq : 1
  var cardholder_name: a26
  var account_num: n19
  var expiration_date: n4
  var track1_data: a79
  window 3, 78
  displaymsinput 1, 2, cardholder_name{m1, 2, 1, *}, "Enter Guest Name", \
                2, 2, account_num{m1, 1, 1, *}, "Enter Account Number", \
                3, 2, expiration_date{m1, 3, 1, 4}, "Enter Expiration"

  windowinput
  waitforclear
endevent

```

### See Also

**Display**, **DisplayInput**, **DisplayMSInput**, **WaitForClear**, **WaitForConfirm**, **WaitForEnter**, and **WindowClose** commands

## WindowClose

### Description

This command closes a currently displayed window.

### Syntax

**WindowClose**

---

## Remarks

Windows close automatically when a script is exited, or when a new window is built with the Window command. The **WindowClose** command allows the script writer to close a window before either of these events has occurred.

## Example

The following script builds a window, displays some text, then closes the window (after the operator presses [Clear]):

```
event inq : 1
  window 1, 14
  display 1, 2, "Hello"           //"You say Hello"
  waitforclear
  windowclose
  display 1, 2, "Goodbye"       // "and I say Goodbye" waitforclear
endevent
```

## See Also

Window command

## Window[Edit/Input][WithSave]

### Description

One of these commands is required any time the **DisplayInput** and **DisplayMSInput** commands are used. The **WindowEdit** and **WindowInput** determine whether the contents of the variables are cleared before being displayed. The [WithSave] option, with either command, determines how the input session will be terminated.

### Syntax 1

WindowEdit[WithSave]

### Syntax 2

WindowInput[WithSave]

## Remarks

- When one of the **WindowEdit** or **WindowInput** commands is found, the SIM will look for the first and subsequent **DisplayInput** or **DisplayMSInput**, since the window was drawn and executes it. Therefore, the **WindowEdit** and **WindowInput** command must be preceded by both a Window command and at least one **DisplayInput** or **DisplayMSInput** command.
- The **WindowEdit** and **WindowEditWithSave** commands do not clear the variables. If the *input\_variables* contain data, the contents will be displayed in the input window. These commands are useful when the operator must change only a few fields or characters of a record. The **WindowInput** and **WindowInputWithSave** commands clear the variables before they are displayed. All previous information in the fields is lost after the command is executed. These commands are useful for entering new information.
- **WindowEditInput** can be used with the **Display[MS]Input** commands to build a screen of input fields to accept input from the user. Navigating among the input fields is achieved with the movement keys: up arrow, down arrow, home,

---

and end. [Enter] can also be used to navigate, which moves the focus to the next field, and [Clear], which moves the focus to the previous field.

- The **WindowInput** and **WindowEdit** commands complete the Input session when the cursor is on the last field and the user presses the [Enter] key or the [Down Arrow] key. The Input session is cancelled if the cursor is on the:
  - First field and the user presses the [Clear] key or the [Up Arrow] key.
  - Last field and the user presses [Enter] or [Down Arrow].
- The **WindowInputWithSave** and **WindowEditWithSave** commands require the operator to either press the [Save] key to complete the Input session or press the [Cancel] key to cancel it. If the cursor is on the last edit field and either the [Enter] key or the [Down Arrow] key is pressed, the cursor will roll to the first field. Likewise, if the cursor is on the first edit field and either the [Clear] key or the [Up Arrow] key is pressed, the cursor will roll to the last field.

### Example 1

The following script will read the information from Track 1 of a credit card:

```
event inq : 1
  var cardholder_name: a26
  var account_num: n19
  var expiration_date: n4
  var track1_data: a79

  window 3, 78
  displaymsinput 1, 2, cardholder_name{m1, 2, 1, *}, "Enter Guest Name", \
    2, 2, account_num{m1, 1, 1, *}, "Enter Account Number", \
    3, 2, expiration_date{m1, 3, 1, 4}, "Enter Expiration"

  windowinput
  waitforclear
endevent
```

### Example 2

The following script will allow input of customer information in a window:

```
event inq : 1
  var name : a20
  var address1 : a20
  var address2 : a20
  var city : a20
  var state : a2
  var zip : a10
  var tel : a12
  window 7, 33
  display 1, 2, " Name:"
  display 2, 2, " Address1:"
  display 3, 2, " Address2:"
  display 4, 2, " City:"
  display 5, 2, " State:"
  display 6, 2, " Zip:"
  display 7, 2, "Telephone:"

  displayinput 1, 13, name, "Enter name"
  displayinput 2, 13, address1, "Enter address1"
  displayinput 3, 13, address2, "Enter address2"
  displayinput 4, 13, city, "Enter city"
  displayinput 5, 13, state, "Enter state"
  displayinput 6, 13, zip, "Enter zip"
```

---

```
displayinput 7, 13, tel, "Enter telephone number"  
windoweditwithsave  
txmsg "new_member", name, address1, address2, city, state, zip, tel  
waitforrxmsg
```

endevent

### **See Also**

**DisplayInput**, **DisplayMSInput**, and **Window** commands

---

---

## 9 ISL Functions

This chapter summarizes all ISL Functions in and A-to-Z reference.

### Functions

In addition to commands, ISL provides a variety of functions to enhance text handling and formatting facilities. Each function returns a value which may be useful for certain applications.

All function arguments must be enclosed in parentheses.

### Function Summary

The following table contains a list of function names, a brief description, and the function type of the returned integer/character/key.

**Table 112 ISL Function Summary**

Function	Description	Function Type
Abs()	Returns the absolute value of the integer or decimal.	Integer
ArraySize()	Returns the declared size of the array.	Integer
Asc()	Returns the ASCII integer value of the first character of the string.	Integer
Bit()	Returns the value of a bit in a hexadecimal string.	Integer
Chr()	Returns a one-character string that is the character representation of an integer.	Character
CommandExists()	Returns the true if the SIM command exists.	String
DefKey()	Returns a key value for LoadKybdMacro.	
Env()	Returns a value of a shell environment variable.	Integer
Feof()	Determines if the file pointer is at the end of the file.	Integer
FormatCheckData()	Returns the image of the current check give the language ID.	
FormatCurrentDate()	Returns the formatted date/time with the given format string.	String
FormatStr()	Formats a string given a format string and variable number of arguments.	
FormatValue()	Returns the formatted value (integer, string, decimal) given the format string.	String
FTell()	Gets the file position in a file.	Integer
GetHex()	Converts a hex string to an integer.	Integer

Function	Description	Function Type
GetValue()	Returns the value of a key's property.	Key, String
Instr()	Returns the index of the first occurrence of a character string.	Character
Key()	Returns the key variable associated with the key pair.	Key
KeyNumber()	Returns the number portion of the key variable.	Integer
KeyType()	Returns the type portion of the key variable.	Integer
Len()	Returns the length of a string.	Integer
Mid()	Extracts part of a string to a string field.	Character
SplitString()	Splits the passed in value given the separator and returns a .net ArrayList.	String
Str()	Converts the passed in value into a string.	
SystemVariableExists()	Returns the true if the SIM system variable exists.	String
ToInteger()	Returns an integer from a decimal value.	Integer
Trim()	Returns a string trimmed of leading and trailing spaces.	Character
TypeOf()	Returns a string representation of the .net Type name passed in.	Value
VarExists()	Returns the true if the user-defined variable exists at the current scope.	String
VarSize()	Returns the declared size of a variable.	Integer

## ISL Function Reference

This section includes all functions supported by the ISL in an A-Z reference format, which includes the following information for each function:

- **Description:** summarizes the function's purpose.
- **Syntax:** provides the proper way to specify the function and any arguments, as well as a description of each argument.
- **Remarks:** gives more detailed information of the function, its arguments, and how the function is used.
- **POS Setup:** provides any Symphony database programming required to issue the function successfully.
- **Example:** includes an example of the function being used in a script.
- **See Also:** names related functions, commands, system variables, and other documentation worth consulting.

---

## Abs Function

### Description

This function returns the absolute value of the integer or decimal value.

### Syntax

**Abs** (*integer or decimal*)

**Table 113 Abs Function Arguments**

Argument	Description
<i>integer</i>	An integer expression to be converted.
<i>decimal</i>	A decimal expression to be converted.

### Example

```
event inq : 1
  var int : N5 = -145
  var mon : $8 = -12.35
  waitforclear abs(int)           //will display `145`
  waitforclear abs(mon)          //will display `12.35`
  waitforclear abs("-34")        //will display error
endevent
```

## ArraySize Function

### Description

This function returns the size (number of elements) of the array passed in.

### Syntax

**ArraySize** (*array\_name*)

**Table 114 ArraySize Function Arguments**

Argument	Description
<i>array_name</i>	The name of the array.

### Remarks

The array name must be placed between the parentheses without brackets. For example, the following references are illegal:

```
arraysize (list [ ])
arraysize (list [2])
```

The following entry is correct:

```
arraysize(list)
```

### Example

The following subroutine returns the declared size (number of elements) of an array.

```
sub array_size
  var array_test[100] : a50
  waitforclear "Size of array_test is ", arraysize(array_test)
  //Would prompt "Size of 100"
  // array_test is
endsub
```

---

## Asc Function

### Description

This function returns the ASCII integer value of the first character of the string passed in.

### Syntax

*Asc* (*string\_expression*)

**Table 115 Asc Function Arguments**

Argument	Description
<i>string_expression</i>	A place holder for text characters such as a <i>user_variable</i> ( <i>string</i> ).

### Remarks

The process of returning a value with the **Asc** function works opposite of the **Chr** function.

### Example

The following subroutine displays the ASCII value of the first character of a string:

```
sub asc_value
  var asc_val : n3
  asc_val = asc("MICROS")
  waitforclear "The ascii value of M = ", asc_val
                                                    //Would prompt "The ascii
                                                    // value of M = 77"
endevent
```

### See Also

**Chr** function

## Bit Function

### Description

This function will return the value (0 or 1) of a bit in a hexadecimal string.

### Syntax

*Bit* (*hex\_string*, *bit\_position*)

**Table 116 Bit Function Arguments**

Argument	Description
<i>hex_string</i>	A place holder for the hexadecimal string that will be examined.
<i>bit_position</i>	The index of the bit whose value is desired.

### Remarks

- The Bit function would generate an error if the string passed in contains non-hex characters. For example, the following statement will generate an error since the = character is not a hex digit:

```
i = gethex( "12AB=" )
```

- Valid hex digits are 0-9, A-F, and a-f.
- The *bit\_positions* are numbered consecutively from 1. In the example below, a four-digit hexadecimal number would have bits numbered from 1 to 16. The digit values are determined by the standard hexadecimal assignment of bit values (for example, within each digit, bit 1 = 8, bit 2 = 4, bit 3 = 2, bit 4 = 1).

**Table 117 Example Bit Positions for a four Digit Hexadecimal Number**

Digit Position	1				2				3				4			
bit_position	1	2	3	4	5	6	7	8	9	10	11	12	13	14	15	16
digit value	1				2				F				E			
bit value	0	0	0	1	0	0	1	0	1	1	1	1	1	1	1	0

### Example

In the above example, the following command would result in *i* being set to 1.

```
i = bit("12FE", 7) //i will be set to 1
```

Thus, in all hex\_strings, bit\_position 1 corresponds to the highest bit value in the first of the string.

## Chr Function

### Description

This function returns a one-character string that is the character representation of the integer passed in.

### Syntax

**Chr** (*integer*)

**Table 118 Chr Function Arguments**

Argument	Description
<i>integer</i>	An integer in the range from 32 to 255.

### Remarks

The process of returning a value with the **Chr** function is the opposite of the **Abs** function.

### Example

The following subroutine constructs the name of a POS company using ASCII values:

```
sub make_name
  var ascii_array[6] : n3
  var pos_king      : a6
  var arr_cnt : n3

  ascii_array[1] = 77
  ascii_array[2] = 73
  ascii_array[3] = 67
  ascii_array[4] = 82
```

```

ascii_array[5] = 79
ascii_array[6] = 83

for arr_cnt = 1 to 6           //Count through the array
    format pos_king as pos_king, chr(ascii_array[arr_cnt])
endfor
waitforclear "The POS king is ", pos_king
endsub

```

## See Also

Display command

## CommandExists Function

### Description

This function returns true if the SIM command exists

### Syntax

CommandExists (string)

**Table 119 Abs Function Arguments**

Argument	Description
<i>String</i>	The string of the command

### Example

```

event inq : 1
    waitforclear CommandExists( "WaitForClear" )
endevent

```

## DefKey Function

### Description

This function returns a key value for LoadKybdMacro

### Syntax

(see DefKey discussion in SIM addendum)

## Env Function

### Description

This function returns the value of a shell environment variable.

### Syntax

Env (*environment\_variable*)

**Table 120 Env Function Arguments**

Argument	Description
<i>environment_variable</i>	The environment variable to return.

---

## Remarks

An empty string will be returned if the environment variable does not exist.

## Example

Assume that the environment variable "Term" is "ansi":

```
var term : a20 = env("Term")           //term will be "ansi"
```

## Feof Function

### Description

This function tests whether the file pointer is at the end of the file.

### Syntax

`Feof` (*file\_number*)

**Table 121 Feof Function Arguments**

Argument	Description
<i>file_number</i>	An integer variable which was assigned in the <b>FOpen</b> statement when the file was opened.

## Remarks

A 1 is returned if there is no more data left to read, and a 0 is returned if there is more data left to be read.

## Example

The following example shows how to use the **Feof** function as the condition of a **While** command:

```
while not feof( fn )
    call process_data( fn )
    .
    .
endwhile
```

## See Also

**FClose**, **FOpen**, and **While** commands

## FormatCheckData Function

### Description

This function returns the image of the current check given the language ID.

### Syntax

`FormatCheckData` (integer)

**Table 122 Abs Function Arguments**

Argument	Description
<i>Integer</i>	The language ID to use when formatting

---

## Example

```
event inq : 1
  var text:A = FormatCheckData( @OpsContext.CurrentLangId )
endevent
```

## FormatCurrentDate Function

### Description

This function returns the formatted date/time with the given format string.

### Syntax

FormatCurrentDate(string)

Table 123 Abs Function Arguments

Argument	Description
<i>String</i>	Format string. This method directly calls the .net API System.DateTime.Now.ToString()

### Example

```
event inq : 1
  var text:A = FormatCurrentDate( "yyyy/MM/dd HH:mm:ss" )
endevent
```

## FormatDate Function

### Description

This function returns the unformatted date/time with the given format string.

### Syntax

FormatCurrentDate(string)

Table 124 Abs Function Arguments

Argument	Description
<i>String</i>	Format string. This method directly calls the .net API System.DateTime.Now.ToString()

### Example

```
event inq : 1
  var text:A = FormatCurrentDate( "yyyy/MM/dd HH:mm:ss" )
endevent
```

## FormatStr Function

### Description

This function will format a string given a format string and variable number of arguments. This method uses the .net API String.Format() method.

### Syntax

FormatStr(format,value1,value2)

---

**Table 125 Abs Function Arguments**

Argument	Description
<i>Format</i>	The format string. See .net API documentation for string.Format()
<i>ValueX</i>	Elements to be formatted

### Example

```
event inq : 1
  var text:a = FormatStr( "Value must be between {0} and {1}", min, max )
endevent
```

## FormatValue Function

### Description

This function returns the formatted value (integer, string, or decimal) given the format string.

### Syntax

FormatValue(value,string)

**Table 126 Abs Function Arguments**

Argument	Description
<i>Value</i>	The value to be formatted.
<i>String</i>	Format string. This method directly calls the .net API Int64, String, or Decimal method

### Example

```
event inq : 1
  var text:A = FormatValue(123, "N3")
endevent
```

## FTell Function

### Description

This function returns the file position in a file.

### Syntax

FTell (*file\_number*)

**Table 127 FTell Function Arguments**

Argument	Description
<i>file_number</i>	An integer variable which was assigned in the <b>FOpen</b> statement when the file was opened.

### Example

The following example will read a certain field position:

```
sub find_emp
```

```

while not feof( fn )
current_position = ftell( fn )           //Remember this position.

fread fn, emp_number, *                  //Read first field.
if emp_number = target_emp_number       //If match, reposition back
    fseek fn, current_position          // to original position and
    return                               // let calling function
endif                                     // reread data.
endwhile
endsub

```

## See Also

**FClose**, **FOpen**, **FRead**, **FSeek**, and **While** commands

## FunctionExists

### Description

This function returns the true if the SIM function exists

### Syntax

FunctionExists (string)

**Table 128 Abs Function Arguments**

Argument	Description
<i>String</i>	The string of the function

### Example

```

event inq : 1
    waitforclear FunctionExists( "abs" )
endevent

```

## GetHex Function

### Description

This function will convert a Hex string to a decimal integer.

### Syntax

**GetHex** (*hex\_string*)

**Table 129 GetHex Function Arguments**

Argument	Description
<i>hex_string</i>	The <i>string</i> to be converted.

**Remarks**

- The **GetHex** function generates an error if the string passed in contains non-hex characters. The following statement will generate an error since the = character is not a hex digit, for example:  
`i = gethex( "12AB=" )`
- A string should be made up of any combination of the following characters 0- 9, a - f, or A - F.

**Example**

The following subroutine converts a hex string to its decimal equivalent:

```
sub hex_2_dec
  var hex_str: a4 = "FFFF"
  waitforclear "The decimal equiv of 'FFFF' is ", gethex(hex_str)
endsub
```

**GetValue Function**

**Description**

This function returns the value of a key’s property. This method is useful to extract a key’s individual components.

**Syntax**

```
FormatValue(key,string)
```

**Table 130 Abs Function Arguments**

Argument	Description
<i>Key</i>	The source key value
<i>String</i>	The key to extract.

**Example**

```
event inq : 1
  var myKey:key = defkey("Payment", N:2, A:"Cash:Cash")

  // argument will contain "Cash:Cash"
  var val:A = GetValue (myKey, "A")

  // argument will contain "2"
  val = GetValue (myKey, "N")

endevent
```

---

## Instr Function

### Description

This function will return the index of the first occurrence of a character in a string.

### Syntax

**Instr** (*index*, *string\_expression*, *character*)

**Table 131 Instr Function Arguments**

Argument	Description
<i>index</i>	Starting position of the search for the specified character
<i>string_expression</i>	The <i>string_expression</i> to be searched; can be one of the following: <ul style="list-style-type: none"><li>• <i>user_variable</i></li><li>• <i>system_variable</i></li><li>• <i>constant</i></li><li>• <i>string</i></li><li>• <i>function</i></li><li>• <i>equation</i></li></ul>
<i>character</i>	Character to search for.

### Example

The following statement will set *i* equal to 5, since "E" is the 5th character in the string:

```
i = instr( 2, "ABCDEFGHILJ", "E" )           //i will be set to 5
```

## Key Function

### Description

This function will execute the key function code defined.

### Syntax

**Key** (*key\_pair*)

**Table 132 Key Function Arguments**

Argument	Description
<i>key_pair</i>	A link to a specific workstation key in the form of: <i>key_type</i> : <i>key_number</i> .

### Remarks

- The *key\_type* determines the type of key (for example, Function, Keypad); the *key\_number* designates the specific Key Code.
- For a list of key codes and names, see Key Types, Codes, and Names.

---

## Example

The following script begins a check by number, then orders several menu items and prints the check:

```
event inq : 1
  loadkybdmacrokey (11,400), \           //Begin check
    key (1, 552), key(1,554), key (1,555),\ //Order Menu Items
    key (7, 101)                       //Service Total
                                         // check
endevent
```

## See Also

KeyNumber and KeyType functions

## KeyNumber Function

### Description

This function will return the key number (integer) portion of a key expression.

### Syntax

**KeyNumber** (*key\_expression*)

**Table 133 KeyNumber Function Arguments**

Argument	Description
<i>key_expression</i>	An <i>expression</i> that can be one of the following: <ul style="list-style-type: none"><li>• @KEY...<i>system_variable</i></li><li>• <i>user_variable</i>(<b>KeyType</b>)</li><li>• <b>Key</b> function</li></ul>

## Example

The following script reports the number and type of the [Enter] key:

```
event inq : 1
  var key_var : a20 = "9,12"

  window 3, 26
  display 1, 2, "Enter key's key pair is", key_var
  display 1, 2, "Enter key's key type is", keytype(key_var)
  display 1, 2, "Enter key's key number is", keynumber(key_var) //keynumber = 12
waitforclear endevent
```

## See Also

Key and KeyType functions

## KeyType Function

### Description

This function will return the key type (integer) portion of a key expression.

### Syntax

**KeyType** (*key\_expression*)

**Table 134 KeyType Function Arguments**

Argument	Description
<i>key_expression</i>	An <i>expression</i> that can be one of the following: <ul style="list-style-type: none"> <li>• @KEY...system_variable</li> <li>• user_variable(<b>KeyType</b>)</li> <li>• <b>Key</b> function</li> </ul>

### Example

The following script reports the number and type of the [Enter] key:

```
event inq : 1
    var key_var : a20 = "9,12"

    window 3, 26
    display 1, 2, "Enter key's key pair is", key_var
    display 1, 2, "Enter key's key type is", keytype(key_var)//key_type = 9
    display 1, 2, "Enter key's key number is", keynumber(key_var)
    waitforclear
endevent
```

### See Also

Key and KeyNumber functions

## Len Function

### Description

This function is used to determine the length of a string or string variable.

### Syntax

Len (*string\_expression*)

**Table 135 Len Function Arguments**

Argument	Description
<i>string_expression</i>	The string length to be returned.

### Example

The following script takes a list of names from the PMS and tests each name for its length. It then builds a window and displays the names. The longest string determines the width of the window.

```
event rxmsg : guest_list
    var guest_list_size : n3
    var guest_list[14] : a78
    var arrcnt : n3
    var longestr : n3

    rxmsg guest_list_size, guest_list[] //Receive size and list from PMS

    for arrcnt = 1 to guest_list_size //Count through the array to
        if longestr < len(guest_list[arrcnt]) // find the longest member.
            longestr = len(guest_list[arrcnt])//If this member is longer than
        endif // the longest so far, set
```

```

endfor                                // longestr equal to its length.

window guest_list_size, longestr + 2  //Build the window as high as
for arrcnt = 1 to guest_list_size      // the number of guests in the
    display arrcnt, 2, guest_list[arrcnt] // list and as wide as the
endfor                                  // longest guest name + 2.
waitforclear                            //Display the names and wait
endevent                                 // for user to press clear.

```

## Mid Function

### Description

This function is used to extract text from a string. This function is not to be confused with the **Mid** command.

### Syntax

**Mid** (*string\_expression*, *start*, *count*)

**Table 136 Mid Function Arguments**

Argument	Description
<i>string_expression</i>	A string or user_variable (string).
<i>start</i>	The starting offset (character) within the field.
<i>count</i>	The number of characters to be read.

### Remarks

This command is like the BASIC language "mid\$" function.

### Example

The following subroutine searches a string for a specified character, starting at a specified place in the string, then returns the location of the character. The extracted text is compared to the desired characters. This example assumes that the calling routine declares the following four variables, and defines the first three:

```

//start:      n3           position in string to start search, 1 if not defined
// string     :a??        string to search
// search_char :a1        character to search for
// charpos    :n3        the subroutine will set this variable equal to the
//                location where the search_char is found in the
//                string; it will be 0 if search_char is not found

sub instr
    if start <= 0          //If user didn't define start
                           // set it = 1
        start = 1
    endif

    for charpos = start to len(string)
        if search_char = mid(string, charpos, 1) //If we find the search_char,
                                                // return the charpos

            return
        endif
    endfor
    charpos = 0            //If not found, set charpos = 0 endsub

```

---

## See Also

Mid command

## SplitString Function

### Description

This function will split the passed in value given the separator and return a .net ArrayList.

### Syntax

FormatValue(value,string)

Table 137 Abs Function Arguments

Argument	Description
<i>Value</i>	The value to split. This can be integer, decimal, or string. All values will be converted to strings before the split operation.
<i>String</i>	The separator. This method uses the .net API String.Split method.

### Example

```
event inq : 1
    // items will contain 4 elements.
    var items:object = SplitString( "a,b,c,d", "," )

endevent
```

## Str Function

### Description

This function will convert the passed in value into a string.

### Syntax

Str(value)

Table 138 Abs Function Arguments

Argument	Description
<i>Value</i>	The value to convert to a string. Integers and decimals will be converted, strings will remain as-is.

### Example

```
event inq : 1
    // items will contain 4 elements.
    var items:object = SplitString( "a,b,c,d", "," )

endevent
```

---

## SystemVariableExists Function

### Description

This function returns the true if the SIM system variable exists.

### Syntax

SystemVariableExists (string)

**Table 139 Abs Function Arguments**

Argument	Description
<i>String</i>	The string of the system variable

### Example

```
event inq : 1
    waitforclear SystemVariableExists( "ckemp" )
endevent
```

## ToInteger Function

### Description

This function returns an integer from a decimal value by removing the decimal point. This assumes that the new value will be interpreted correctly. For example, the PMS knows where the decimal is placed.

### Syntax

ToInteger (*decimal*)

**Table 140 ToInteger Function Arguments**

Argument	Description
<i>decimal</i>	A <i>decimal</i> expression to be converted.

### Remarks

The decimal point will be removed when returned.

### Example

```
event inq : 1 var n : N5
    n = 12.45 //n will equal '12'
    n = tointeger( 12.45 ) //n will equal '1245'
endevent
```

## Trim Function

### Description

This function is used to remove leading and trailing spaces from text or variable fields.

### Syntax

Trim (*string\_expression*)

---

**Table 141 Trim Function Arguments**

Argument	Description
<i>string_expression</i>	A <i>string</i> or <i>user_variable</i> ( <i>string</i> ).

### Example

The following subroutine trims leading and trailing spaces from a string:

```
sub trim_spaces
  var string : a32 = "  many spaces" var trimmed_str : a11
  trimmed_str = trim(string) //Result would be "many spaces"
endsub
```

## TypeOf Function

### Description

This function will return a string representation of the .net Type name passed in.

### Syntax

TypeOf(value)

**Table 142 Abs Function Arguments**

Argument	Description
<i>Value</i>	The type name of the .net class. This name does not have to be fully qualified. This allows a script writer to troubleshoot scripts when class names do not appear to resolve to the appropriate value.

### Example

```
event inq : 1
  // text will contain "System.String"
  var text:A = TypeOf( "String")
endevent
```

## VarExists Function

### Description

This function returns true if the user-defined variable exists at the current scope.

### Syntax

VarExists(string)

**Table 143 Abs Function Arguments**

Argument	Description
<i>String</i>	Name of the variable

### Example

```
event inq : 1
  var myVar:n
  var exists:n = VarExists( "myVar" )
```

---

endevent

## VarSize Function

### Description

This function returns the declared size of a variable.

### Syntax

**VarSize** (*user\_variable*)

**Table 144 VarSize Function Arguments**

Argument	Description
<i>user_variable</i>	The name of the <i>user_variable</i> to be "sized".

### Example

The following script displays the declared size of a very large string:

```
event inq : 12
    var big_string : a200
    waitforclear "BIG_STRING'S size is ", varsize(big_string)
    //would prompt "BIG_STRING'S size is 200"
Endevent
```



---

---

# 10 Android Barcode Scanner

## Overview

The Symphony Android POS client has the capability to read barcodes and QR codes from Android device's camera using third party library Google MLkit.

The key functions of the Android Barcode scanner feature are:

- The Android POS application opens the camera with a button click.
- SIM scripts subscribe to Barcode events
- When a barcode or QR code is scanned, the POS sends the SIM Barcode event to all subscribed

SIM scripts.

- The SIM scripts examine the Barcode data and displays the data, the format and the type of Barcode or QR code on Ops.

## Subscribing to Barcode Scanner Events

SIM scripts use the standard model for subscribing to POS events.

```
SIM
event init
  SubscribeToEvent "OpsBarcodePreviewEvent", "BarcodePreviewEvent"
endevent
```

## Consuming Barcode Scanner Events

The Barcode Scanner event follows the standard SIM event method signature.

```
SIM
event BarcodePreviewEvent( var sender: object, var args: object)
  if not args.Handled
    args.Handled = 1;
    @OpsContext.ShowMessage(System.String.Format( "Received barcode
Type {0} Format {1} BarcodeString {2} RawBarcodeString {3}",
args.BarcodeType, args.BarcodeFormat, args.BarcodeString,
args.RawBarcodeString))
  ExitCancel
end if
endevent
```

All SIM scripts that subscribe to this event are executed. It is critical to validate that no other SIM script has consumed this data. It is also important for SIM scripts to set Handled to 1, so that Barcode events are not processed twice. This should only be done if the SIM event consumes the Barcode scanner data.

## Barcode Scanner Event Args

The class passed in as args is the following:

```
C#
public class OpsBarcodePreviewEventArgs : OpsEventMonitorArgs
```

```

{
    public OpsBarcodePreviewEventArgs( bool manuallyEntered,
string barcodeString, int barcodeFormat = 0, int barcodeType =
0, string rawBarcodeString = "")
        : base( OpsEventType.OpsBarcodePreviewEvent, true )
    {
        mSimEventType = EventTypes.Barcode;
        EventType = OpsEventType.OpsBarcodePreviewEvent;
        mSimEventId = StringEnum.GetStringValue(
EventIds.Confirm );
        ManuallyEntered = manuallyEntered;
        BarcodeType = barcodeType;
        BarcodeFormat = barcodeFormat;
        BarcodeString = barcodeString;
        RawBarcodeString = rawBarcodeString;
    }

    public bool ManuallyEntered { get; private set; }
    public int BarcodeType { get; private set; }
    public int BarcodeFormat { get; private set; }

    public string BarcodeString { get; private set; }
    public string RawBarcodeString { get; private set; }
    public bool Handled { get; set; }
}

```

Notes:

- **ManuallyEntered:** Set if the barcode is keyed in rather than scanned, using an Ops command.
- **BarcodeType:** Set and get the barcode or QR code type
- **BarcodeFormat:** Set and get the barcode or QR code format
- **BarcodeString:** Set and get the barcode or QR code string data
- **RawBarcodeString:** Sometimes the barcode or QR code string data is set as rawdata
- **Handled:** set to true when a SIM script consumes this Barcode

## Limitations

This feature is only available for Android devices with a camera.

## Barcode Scanner Objects

This class is a thin wrapper around Google MLkit Barcode class. We have wrapped the methods that we think are useful for this feature from MLkit.

```

SIM
using Micros.Ops.Hardware;

namespace Symphony.Android.CameraBarcode
{
    // FPPRT-3801. Android device camera barcode scanner

```

```

public class CameraBarcode : IDroidBarcode
{
    private readonly
Xamarin.Google.MLKit.Vision.Barcode.Common.Barcode
_nativeBarcode;

    public
CameraBarcode(Xamarin.Google.MLKit.Vision.Barcode.Common.Barcode
nativeBarcode)
    {
        _nativeBarcode = nativeBarcode;
    }

    public int Format { get => _nativeBarcode.Format; }
    public int ValueType { get => _nativeBarcode.ValueType; }
}

    public string DisplayValue { get =>
_nativeBarcode.DisplayValue; }
    public string RawValue { get =>
_nativeBarcode.RawValue; }
}
}

```

## Barcode Formats

Barcode.FORMAT\_UNKNOWN  
Barcode.FORMAT\_ALL\_FORMATS  
Barcode.FORMAT\_CODE\_128  
Barcode.FORMAT\_CODE\_39  
Barcode.FORMAT\_CODE\_93  
Barcode.FORMAT\_CODABAR  
Barcode.FORMAT\_DATA\_MATRIX  
Barcode.FORMAT\_EAN\_13  
Barcode.FORMAT\_EAN\_8  
Barcode.FORMAT\_ITF  
Barcode.FORMAT\_QR\_CODE  
Barcode.FORMAT\_UPC\_A  
Barcode.FORMAT\_UPC\_E  
Barcode.FORMAT\_PDF417  
Barcode.FORMAT\_AZTEC

## Barcode Types

Barcode.TYPE\_UNKNOWN  
Barcode.TYPE\_CONTACT\_INFO  
Barcode.TYPE\_EMAIL  
Barcode.TYPE\_ISBN

---

Barcode.TYPE\_PHONE  
Barcode.TYPE\_PRODUCT  
Barcode.TYPE\_SMS  
Barcode.TYPE\_TEXT  
Barcode.TYPE\_URL  
Barcode.TYPE\_WIFI  
Barcode.TYPE\_GEO  
Barcode.TYPE\_CALENDAR\_EVENT  
Barcode.TYPE\_DRIVER\_LICENSE

## Sample SIM Script

```
SIM
endevent
event inq: scanbarcode
    // Open the camera and allow a barcode scan
    @OpsContext.CameraScanBarcodeOpen()
endevent

event BarcodePreviewEvent( var sender: object, var args: object )
    // Set to ExitCancel to consume the barcode here
    // Set to ExitContinue to pass the barcode back to Ops
    if not args.Handled
        args.Handled = 1
        @OpsContext.ShowMessage(System.String.Format( "Received
barcode Type {0} Format {1} BarcodeString {2} RawBarcodeString
{3}", args.BarcodeType, args.BarcodeFormat, args.BarcodeString,
args.RawBarcodeString)
        //ExitContinue
        ExitCancel
    endif
endevent
```

---

---

# 11 Android NFC Support

## Overview

The Symphony Android POS client has the capability to read Near Field Communication (NFC) tags via the SIM module. The following NFC tag types are supported:

- IsoDep
- Mifare Classic
- Mifare Ultralight

The key functions of the Android NFC feature are:

- The Android POS application listens for all NFC tags while it is active
- SIM scripts subscribe to NFC events
- When a NFC tag is scanned, the POS sends the SIM NFC event to all subscribed SIM scripts.
- The SIM scripts examine the NFC tag data and determine if they should consume the event.

## Subscribing to NFC Events

SIM scripts use the standard model for subscribing to POS events.

```
SIM
event init
SubscribeToEvent "OpsAndroidNfcEvent", "NfcEvent"
endevent
```

NFC events are only available in Android. A SIM script running in Windows or Linux can subscribe to the event, however, the event will not fire.

## Consuming NFC Events

The NFC event follows the standard SIM event method signature.

```
SIM
event NfcEvent( var sender: object, var args: object)
endevent
```

All SIM scripts that subscribe to this event are executed. It is critical to validate that no other SIM script has consumed this tag data. It is also important for SIM scripts to set **Handled** to **1**, so that NFC events are not processed twice. This should only be done if the SIM event consumes the NFC data.

```
SIM
event NfcEvent( var sender: object, var args: object)
if not args.Handled
args.Handled = 1;
endif
endevent
```

---

## NFC Event Args

The class passed in as args is:

```
C#
namespace Micros.PosCore.Extensibility.Ops
{
    public class OpsAndroidNfcEventArgs : OpsEventMonitorArgs
    {
        public object Tag { get; }
        public bool Handled { get; set; }
    }
}
```

Notes:

- Tag: the wrapped NFC Tag class
- Handlers: set to true when a SIM script consumes this NFC tag

## Limitations

Keep the following limitations in mind when implementing the NFC SIM:

- Android only supports SIM, not the full .net assembly extensibility. This is a limitation of the Android OS. An Android application cannot load an assembly that is not part of the APK.
- SIM has the capability to access standard .net framework objects such as System.Text.StringBuilder. While Android Xamarin C# applications have access to the full Android API, SIM cannot access those Android API objects. Therefore, any seeming Android API objects (such as Android.Nfc.Tech.IsoDep) have been wrapped in a C# SIM-accessible object with the same methods and properties.
- SIM does not support any .net async or Task features, meaning that all NFC reads must take place inline.
- NFC support is currently available only on Android, not on Windows or Linux SIM modules.
- SIM scripts should process NFC connect/read/close as fast as possible. Whether C# or SIM, applications must read the NFC tags quickly. Since SIM is interpreted, it will be read slower than native C#.

## Sundry SIM Features

The following minor SIM features are useful for developing Android SIM applications for NFC, or SIM applications in general:

- Exceptions caught by SIM are a SimException object. A Format() method provides detailed view/log information.
- Android small screen support now has the Extensibility PMC functionality.
- The SIM command **LogLocalExtensionApplicationMessage**, which logs to the PMC Log page, allows for the SIM writer to log, and inspect data on the device itself as opposed to through popup dialog windows or writing to disk logs.
- SIM arrays initialized inline now have an implicit size declaration. This allows a SIM writer to initialize arrays without needing to specify the array size. For example, the following statements are equivalent:
  - `const myarray[] :N = [144, 90, 10]`

- 
- `const myarray[3] :N = [144, 90, 10]`
  - The SIM function **ToByteArray** converts SIM integer arrays into native C# `byte[]` arrays.
  - The SIM function **ToArrayList** converts SIM arrays into .net framework `System.Collections.ArrayList` objects.
  - The .net class **Micros.PosCore.Extensibility.SIM.Utility.SIMByteList** works with `byte[]` arrays, simplifying the process. See the `SIMByteList` section for more information.
  - The method **@OpsContext.SendExtensibilityHtmlDialogData()** sends string data from a SIM event to the currently active custom HTML dialog. See the `SendExtensibilityHtmlDialogData` section for more information.
  - The custom HTML dialog POS dialog API **setAsyncCallback** method. See the `SendExtensibilityHtmlDialogData` section for more information.

## Android NFC Objects

The SIM NFC classes are thin wrappers around native Android NFC classes. In other words:

- The following methods/property types are not implemented:
  - Task/async related methods
  - `JniPeerMembers` property
  - Class-level Constants
- Classes cannot be instantiated from SIM.
- We recommend that the tech objects be obtained from **Tag.GetTech()** rather than from the static `Get()` tech method.
- The `Tag` and `Tech` objects are thin wrapper objects; consult with the Xamarin/Android online documentation for more information.

Class metadata:

```
C#
namespace Symphony.Android.Nfc
{
    public class Tag
    {
        public object AllocateTech( string tech );
        public bool CloseAnyConnected();
        public int DescribeContents();
        public string FormatForLogging();
        public byte[] GetId();
        public List<string> GetTechList();
    }
}
```

```

C#
namespace Symphony.Android.Nfc.Tech
{
    public class IsoDep : INfcTech
    {
        public Tag Tag { get; }
        public bool IsConnected { get; }
        public bool IsExtendedLengthAduSupported { get; }
        public int MaxTransceiveLength { get; }
        public int Timeout { get; set; }

        public static IsoDep Get( Tag tag );
        public void Close();
        public void Connect();
        public byte[] GetHiLayerResponse();
        public byte[] GetHistoricalBytes();
        public void SetTimeout( int timeout );
        public byte[] Transceive( byte[] data );
    }
}

```

```

C#
namespace Symphony.Android.Nfc.Tech
{
    public class IsoDep : INfcTech
    {
        public Tag Tag { get; }
        public bool IsConnected { get; }
        public bool IsExtendedLengthAduSupported { get; }
        public int MaxTransceiveLength { get; }
        public int Timeout { get; set; }

        public static IsoDep Get( Tag tag );
        public void Close();
        public void Connect();
        public byte[] GetHiLayerResponse();
        public byte[] GetHistoricalBytes();
        public void SetTimeout( int timeout );
        public byte[] Transceive( byte[] data );
    }
}

```

```

C#
namespace Symphony.Android.Nfc.Tech
{
    public class MifareClassic : INfcTech
    {
        public static byte[] KeyDefault { get; }
        public static byte[] KeyMifareApplicationDirectory { get; }
        public static byte[] KeyNfcForum { get; }
        public int BlockCount { get; }
        public int Timeout { get; set; }
        public Tag Tag { get; }
        public int MaxTransceiveLength { get; }
        public int SectorCount { get; }
        public int BlockSize { get; }
        public string Type { get; }
        public int Size { get; }
        public bool IsConnected { get; }

        public static MifareClassic Get( Tag tag );
        public bool AuthenticateSectorWithKeyA( int sectorIndex, byte[] key );
        public bool AuthenticateSectorWithKeyB( int sectorIndex, byte[] key );
        public int BlockToSector( int blockIndex );
        public void Close();
        public void Connect();
        public void Decrement( int blockIndex, int value );
        public int GetBlockCountInSector( int sectorIndex );
        public byte[] GetKeyDefault();
        public byte[] GetKeyMifareApplicationDirectory();
        public byte[] GetKeyNfcForum();
        public void Increment( int blockIndex, int value );
        public byte[] ReadBlock( int blockIndex );
        public void Restore( int blockIndex );
        public int SectorToBlock( int sectorIndex );
        public byte[] Transceive( byte[] data );
        public void Transfer( int blockIndex );
        public void WriteBlock( int blockIndex, byte[] data );
    }
}

```

```

C#
namespace Symphony.Android.Nfc.Tech
{
    public class MifareUltralight : INfcTech
    {
        public Tag tag { get; }
        public bool IsConnected { get; }

        public static MifareUltralight Get( Tag tag );
        public void Close();
        public void Connect();
        public byte[] Transceive( byte[] data );
    }
}

```

## SIMByteList

This class is added to the **Micros.PosCore.Extensibility.SIM.Utility** namespace in PosCore.dll

In general, SIM cannot create or manipulate byte arrays. SIMByteList is used to enable byte array support. The Android NFC API natively deals with byte[] objects. This class can be used by SIM to bypass byte[] objects as parameters to method calls, as well as wrapping byte[] results from API calls.

```

C#
namespace Micros.PosCore.Extensibility.SIM.Utility
{
    public class SIMByteList : List<byte>
    {
        public SIMByteList();
        public SIMByteList( byte[] src );
        public SIMByteList( SIMByteList src );
        public SIMByteList( ArrayList src );

        public static string FormatBytes( byte[] bytes );
        public void AddNumber( int item );
        public string ConvertToInt64String();
        public void InsertNumber( int index, int item );
        public void SetNumber( int index, int item );
        public override string ToString();
    }
}

```

## SIM Custom HTML Dialog Asynchronous Data

SIM receives NFC events while a dialog is displayed and sends the data to the custom dialog HTML application.

There are two steps required in order to achieve this:

1. HTML dialog application: Calling **SimphonyPOSAPI.setAsyncDataCallback()** to define the function to call when a message is received from SIM/Extensibility.
2. SIM application: Calling **@OpsContext.SendExtensibilityHtmlDialogData()** from SIM/Extensibility to send data to the dialog.

```

javascript
<SCRIPT LANGUAGE='JavaScript'>
    function onload()
    {
        SimphonyPOSAPI.setAsyncDataCallback(myCallback);
    }

    function myCallback(data)
    {
        document.getElementById('results').innerText = data;
    }
</SCRIPT>

```

```

SIM
•     sub ShowNfcTag( var text: a )
•         if @OpsContext.ProcessingDialog
•             @OpsContext.SendExtensibilityHtmlDialogData( text )
•         endif
•     endsub

```

### Notes:

- **SendExtensibilityHtmlDialogData** works only when a custom HTML dialog is active; otherwise, it is ignored.
- This method does not work when running the custom HTML dialog in a separate browser (for debugging purposes).
- This method can either be called from SIM (Android) or .net assemblies (Windows/Linux).

- This method must be called on the POS command thread. If extensibility application fields async event occur in a different thread, use `@OpsContext.InvokeOnCommandThread()` to prevent crashes. SIM always runs on the POS command thread, so this is not an issue in Android.
- Only a string is sent to the dialog. It is calling applications responsibility to format any complex data.
- `SendExtensibilityHtmlDialogData` is asynchronous, meaning that it returns immediately. It does not wait for the javascript method to complete its process.

## Sample SIM Script Application with Custom HTML Dialogs

```

SIM
NetImport Micros.PosCore.Extensibility.SIM.Utility

RetainGlobalVar
SetLocalScoping 1

//-----
event init
  SubscribeToEvent "OpsAndroidNfcEvent", "NfcEvent"
  SubscribeToEvent "OpsCustomDialogEvent", "CustomDialogEvent"
endevent

//-----
event NfcEvent( var sender:object, var args:object)
  try
    call ProcessNfcEvent( args )
  catch ex
    var msg:object = new System.Text.StringBuilder()
    msg.AppendLine( @applicationname )
    msg.AppendLine( "Exception processing NFC tag" )
    msg.AppendLine( "-----" )
    msg.AppendLine( args.Tag.FormatForLogging() )
    msg.AppendLine( "-----" )
    msg.AppendLine( ex.Format() )

    LogLocalExtensionApplicationMessage msg.ToString()
    InfoMessage msg.ToString()
  endtry
endevent

//-----
sub ProcessNfcEvent( ref args )
  if not args.Handled
    var techList:object = args.Tag.GetTechList()
    if techList.Contains("android.nfc.tech.IsoDep")
      call ProcessIsoDep( args )
    elseif techList.Contains("android.nfc.tech.MifareClassic")
      call ProcessMifareClassic( args )
    elseif techList.Contains("android.nfc.tech.MifareUltralight")
      call ProcessMifareUltralight( args )
    endif
    args.Handled = 1;
  endif
endsub

//-----
sub ProcessIsoDep( ref args )
  var isoDep:object = args.Tag.AllocateTech("android.nfc.tech.IsoDep")

  isoDep.Connect()

  const nativeSelectCommand[:N = [1,2,3,4,5]

```

```

isoDep.Transceive( ToByteArray( nativeSelectCommand ) )

const desfireReadCommand[]:N = [9,8,7,6,5]
var resultsBytes:object = isoDep.Transceive( ToByteArray( desfireReadCommand
) )

isoDep.Close()

var results:object = new SIMByteList( resultsBytes )

var msg:a = System.String.Format( "IsoDep: {0}",
results.ConvertToInt64String() )
call ShowNfcTag( args, msg )
endsub

//-----
sub ProcessMifareClassic( ref args )
LogLocalExtensionApplicationMessage "processing MifareClassic nfc tag"

var mifareClassic:object =
args.Tag.AllocateTech("android.nfc.tech.MifareClassic")
var keyDefault:object = mifareClassic.GetKeyDefault()

mifareClassic.Connect()

var sector:n = 5
var blockIndex:n

var results:object = new SIMByteList()
var bytes:object

if mifareClassic.AuthenticateSectorWithKeyA( sector, keyDefault )
blockIndex = ( sector * 4 ) + 0
bytes = mifareClassic.ReadBlock( blockIndex )
results.AddRange( bytes )
endif

if mifareClassic.AuthenticateSectorWithKeyA( sector, keyDefault )
blockIndex = ( sector * 4 ) + 1
bytes = mifareClassic.ReadBlock( blockIndex )
results.AddRange( bytes )
endif

mifareClassic.Close()

var msg:a = System.String.Format( "MifareClassic: {0}", results.ToString() )
call ShowNfcTag( args, msg )
endsub

//-----
sub ProcessMifareUltralight( ref args )
LogLocalExtensionApplicationMessage "processing IsoDep nfc tag"

var mifareUltralight:object =
args.Tag.AllocateTech("android.nfc.tech.MifareUltralight")

mifareUltralight.Connect()

var bytes:object
var results:object
var text:object = new System.Text.StringBuilder()

const page0[]:N = [55,0]
bytes = mifareUltralight.Transceive( ToByteArray( page0 ) )
text.Append( SIMByteList.FormatBytes( bytes ) && " " )

const page4[]:N = [55,4]
bytes = mifareUltralight.Transceive( ToByteArray( page4 ) )

```

```

text.Append( SIMByteList.FormatBytes( bytes ) && " " )

const page16[:N] = [5,2]
bytes = mifareUltralight.Transceive( ToByteArray( page16 ) )
text.Append( SIMByteList.FormatBytes( bytes ) && " " )

const page21[:N] = [5,87]
bytes = mifareUltralight.Transceive( ToByteArray( page21 ) )
text.Append( SIMByteList.FormatBytes( bytes ) && " " )

mifareUltralight.Close()

var msg:a = System.String.Format( "MifareUltralight: {0}", text.ToString() )
call ShowNfcTag( args, msg )
endsub

//-----
sub ShowNfcTag( ref args, var msg:a )
var text:a = System.String.Format( "{0}{1}{2}", msg,
System.Environment.NewLine, args.Tag.FormatForLogging() )
LogLocalExtensionApplicationMessage text

if @OpsContext.ProcessingDialog
@OpsContext.SendExtensibilityHtmlDialogData( text )
else
InfoMessage "No dialog active: ", text
endif
endsub

//-----
event inq:1
var parms:object = new
Micros.PosCore.Extensibility.UserInterface.ExtensibilityInPlaceHtmlDialogParamet
ers()
parms.HTML = @DataStore.ReadExtensionApplicationContentTextByNameKey(
@OpsContext.RvcID, @ApplicationName, "html" )
parms.Sender = "MyDialog"
parms.Argument = "argument from ext app: " &&
System.DateTime.Now.ToLongTimeString()
parms.ShowCloseButton = 1
parms.DebugMode = 0
WaitForHtmlDialog parms, "NfcDialogClosed"
endevent

//-----
event dialog:NfcDialogClosed
if len( @HtmlDialogResult ) > 0
@OpsContext.ShowMessage( "Dialog returned: " && @HtmlDialogResult )
endif
endevent

```

## HTML5

```

<html>
<head>
  <link href="Simphony/POSTheme.css" rel="stylesheet" type="text/css" />
  <script src="Simphony/POSDialogAPI.js"></script>

  <style>
    button {
      min-height: 30px;
      min-width: 80px;
    }
  </style>

```

```

</style>

<SCRIPT LANGUAGE='JavaScript'>
    function onload()
    {
        SymphonyPOSAPI.setAsyncDataCallback(myCallback);
    }

    function myCallback(data)
    {
        document.getElementById('results').innerText = data;
    }

    function closeClick()
    {
        SymphonyPOSAPI.closeDialog('');
    }

    function clearClick()
    {
        document.getElementById('results').innerText = '';
    }

</SCRIPT>
</head>

<body onload="onload()">
    <div class="SimphonyPOSDialogWindow SimphonyPOSCenterWindow">
        <table border="0">
            <tr>
                <td colspan='2' class="SimphonyPOSDialogTitleBar">My Custom Dialog</td>
            </tr>
            <tr>
                <td colspan='2'>Results:</td>
            </tr>
            <tr>
                <td><div id='results'></div></td>
            </tr>
            <tr>
                <td align='left'><button class="SimphonyPOSDialogControlButton" onclick='clearClick()'>Clear</button></td>
                <td align='right'><button class="SimphonyPOSDialogControlButton" onclick='closeClick()'>Close</button></td>
            </tr>
        </table>
    </div>
</body>
</html>

```

---

---

# Appendix A ISL Error Messages

This chapter explains the error messages returned by the ISL.

## Error Message Format

Error messages will appear in the center of the workstation, in one of the formats described below. An explanation of the variable information referenced in the format syntax follows.

### Variable Descriptions

- *<error text>*: specifies a detailed explanation of what the error condition or syntax error may be.
- *<line>*: specifies the line number where the error occurred.
- *<column>*: specifies the column number where the error occurred.
- *<error text ( )>*: specifies a detailed explanation, including the specific erroneous data, enclosed in parentheses.

### Format 1

ISL error  
<error text>

### Example

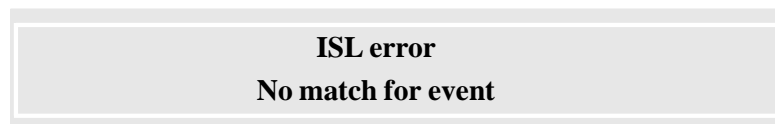

**ISL error**  
**No match for event**

Figure 6 ISL Error Message Format 1

### Format 2

ISL error on line *<line>*  
<error text>

### Example

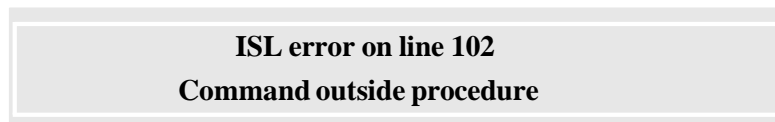

**ISL error on line 102**  
**Command outside procedure**

Figure 7 ISL Error Message Format 2

---

### Format 3

ISL error on line <line>:<column>  
<error text>

#### Example

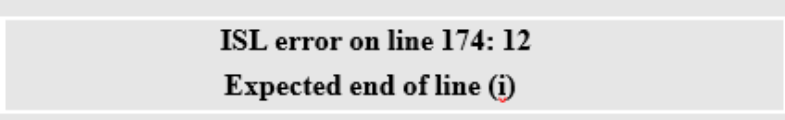

**ISL error on line 174: 12**  
**Expected end of line (i)**

Figure 8 ISL Error Message Format 3

### Format 4

Another type of error occurs when the ISL expected specific text, but encountered different text. This error is displayed as:

ISL error on line <line>  
expected <text>, encountered <text>

For example, if the **Format** command is issued, and the **as** (which is required as part of the syntax) is missing, the following error would display:

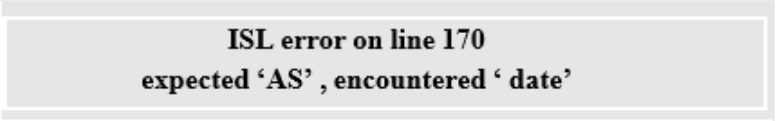

**ISL error on line 170**  
**expected 'AS' , encountered ' date'**

Figure 9 ISL Error Message Format 4

### Format 5

Format 5 is for the KWS (Keyboard Workstation) only.

ISL error:<line number>  
<error text>

#### Example

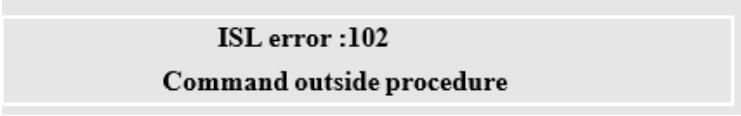

**ISL error :102**  
**Command outside procedure**

Figure 10 ISL Error Message Format 5

## Error Messages

### Array Index Out Of Range

This message occurs if an index number used to access a *list\_array* is invalid.

```
var array[10] : N5
array[12] = 1           //Valid range is 1-10
array[-2] = 4          //No negative numbers
```

---

## Bad Sys Var Index

This message occurs if a *system\_variable* size was out of range.

```
txmsg "MSG", @SI34 //Valid @SI range is 1-16
```

## Break with Too Many Endfor

This message occurs if too many **EndFor** commands occurred within a script without a corresponding **For** command.

```
for i = 1 to 10
    a[i] = 0 endfor
endfor //No corresponding
//for command
```

## Break without Endfor

This message occurs if a Break command is issued within a **For** loop, but there is no **EndFor** command to complete the loop.

## Call Has No Arguments

This message occurs if the subroutine called by the Call command has arguments, but no arguments were specified in the Call command.

```
event inq:1
    call mysub //Mysub has no arguments
endevent

sub mysub( var i:N5 )
.
.
.
endsub
```

## Can Not Evaluate

This message occurs if invalid text was encountered when trying to read an *expression*.

```
display 3, *, "Test"
```

## Cannot Access ISL Script File

This message occurs if the script file was not found, or its permissions were not set correctly.

## Command Outside Procedure

This message occurs if certain commands are issued outside an **Event** procedure.

```
window 10,20 //This must be within the
// event procedure.

event inq:1
.
.
.
endevent
```

---

The following commands are allowed outside an **Event** procedure:

```
ContinueOnCancel
DiscardGlobalVar
ExitOnCancel
Prorate
RetainGlobalVar
SetSignOnLeft
SetSignOnRight
UseBackUpTender
UseCompatFormat
UseISLFormat
UseISLTimeOuts
UseSTDTimeOuts
Var
```

## Decimal Overflow

This message occurs if an attempt to assign a value to a real exceeded the real's storage size.

```
var n : $3
n = 123.45                //n only holds 3 digits
```

## Display Column or Row Out Of Range

This message occurs if the row and/or column declared with the **Display** command is outside the range declared by the **Window** command.

```
window 10, 20
display 11, 1, "Line"    //Row range is 1-10
display 1, 40, "Line"    //Column range is 1-20
```

## Divide by Zero

This message occurs if an attempt was made to divide a numeric value by 0.

```
i = a / 0
```

## Duplicate variable Def

This message occurs if an attempt is made to declare the same variable either within or outside an **Event** procedure.

```
event inq : 1
  var i : N5                //First declaration OK.
  var i : A20              //Redeclaration error.
  .
  .
  .
endevent
```

## Encountered Non-Hex Data

This message occurs if Hexadecimal data was expected, and the string contained non-hex data.

```
i = gethex( "145B*" )    /* is not a hex character
```

---

## Endsub Nesting Mismatch

This message occurs if an **Endsub** occurred within an **Event** command without its corresponding **Sub** command.

```
event inq : 1
.
.
.
endsub
endevent
```

## Evaluation Nesting

This message occurs if an overly complex expression was specified on the command line.

```
i = (((((((((((((((((((((( a + 5 ))))))))))))))))))))
```

## Event Inside Procedure

This message occurs if an **Event** command was encountered within a subroutine.

```
sub check_message
  event inq : 1          //Event within subroutine
  .
  .
  .
endsub
```

## Event Type Must Be Word

This message occurs if an invalid **Event** type was specified in the **Event** line. There are four types of **Events**: Inquire, Tmed, RxMsg, and Final\_Tender.

```
event 123 : 377          //No such event type as
                        // 123
```

## Exceeded Max Array or Variable Size

This message occurs if the *array\_size* or *variable\_size* exceeded the system maximum size of 32768 bytes.

```
var array[100000] : N5
```

## Expected Array in Call

This message occurs if the Sub command had an array argument, but the **Call** command tried to pass a normal variable.

```
event inq:1
  var i:N5
  call mysub( i )          //Has a normal variable
endevent

sub mysub( ref arr[] )    //Has an array
```

## Expected ..., Encountered...

This message occurs when ISL receives unexpected text as part of the command syntax.

---

```
format date @DAY, "-" , month_arr[@MONTH], "-", @YEAR
// "As" is missing after
// the format command
```

## A-Expected Decimal

There are places in ISL where the script writer must specify a decimal number (and not an integer or a string). Using any expression other than a decimal expression results in this error.

For example: the function `tointeger()` expects a decimal number as its argument.

```
i:N5
i = tointeger( 12.34 )           //OK
i = tointeger( 1234 )           //Not ok. 1234 is not
                                // decimal.
i = tointeger( "12.34" )       //Not ok. "12.34" is
                                // not decimal.
```

## Expected End of Line

This message occurs if extraneous data was found at the end of a command line.

```
startprint 12 i                 // Data after 12 is an
                                // error
```

## Expected Format Token

This message occurs if a variable was specified with the **Display** command that did not have a comma after it.

```
display 1, 2, i 123
```

## Expected Operand

This message occurs if an invalid expression was encountered.

```
var i : n5
i = 5 +                               //Invalid expression
```

## Expected String

This message occurs if a command or function expected a string as one of its arguments, and a non-string expression was encountered.

```
var i : n5
setstring i, "a"                     //n : 5 is a non-string
// expression
```

## File Buffer Overflow

This message occurs if an attempt was made to read or write a line to a file, which exceeded the current `@FILE_BFRSIZE`.

```
@FILE_BFRSIZE = 10
fwrite fn, "This string is longer than 10 bytes"
```

## File is Read Only

This message occurs if an attempt was made to write to a file opened for read access only.

---

## File is Write Only

This message occurs if an attempt was made to read from a file opened for write access only.

## File Name Too Long

This message occurs if the file name in the **FOpen** command is greater than 128 characters.

## Format Needs String

This message occurs if the **Format** command requires a *string\_variable* as its first argument.

```
var line : A15
format as "This is a line"           //Missing the variable
                                     // after format command
```

## Format Too Long

This message occurs if the allocated size of the variable to be formatted is smaller than the total length of the expressions to be included.

```
var line : A10
format line as "This line is greater than 10 characters"
```

## Integer Overflow

This message occurs if an attempt to assign a value to an integer exceeded the integer's storage size.

```
var n : N3
n = 12345                             // n only holds 3 digits.
```

## Invalid Decimal Operation

This message occurs if the operation is not allowed on real numbers. Real numbers are amounts, currencies, and decimals.

```
var a : $5, b : $5, c : $5
a = b % c
```

## Invalid File Buffer Size

This message occurs if an attempt was made to assign the `system_variable @FILE_BFRSIZE` to an illegal value. An illegal value would be a value less than or equal to 0.

```
@FILE_BFRSIZE = -20
```

## Invalid File Mode

This message occurs if an invalid mode was specified on the **FOpen** command.

```
fopen fn, "test.log", read and wirte
                                     //The write mode is
                                     // misspelled
```

---

## Invalid File Number

This message occurs if a file number was passed to a File I/O command which was not previously opened.

```
event inq:1
  var fn:N5 = -4
                                     //No fopen declared
  fwrite fn, "hello"
endevent
```

## Invalid First Token

This message occurs if the start of a line contained invalid text.

```
display 2, 3, "Line"
*waitclear                                     /* is invalid
```

## Invalid Input fmt Spec

This message occurs if the input format specification contained invalid data.

```
input name{;}
```

## Invalid List Size

This message occurs if a command which required a list value encountered a list value of 0 or below.

## Invalid Locking Mode

This message occurs if an invalid locking mode was specified in the **Flock** command.

```
flock fn, preventread and write           //Should be preventwrite
                                     // not write
```

## Invalid Output Format

This message occurs if the output format specification contained invalid data.

```
txmsg name{;}
```

## Invalid PMS SEND

This message occurs if the system was unable to send the PMS message.

## Length Invalid

This message occurs if the third argument in the **Mid** command and/or function was less than 0.

## List Value Too Big

This message occurs if the list value in the command exceeded the *array* which it referenced.

```
var list[10] : A20
txmsg 21, list[]                               // Valid range is 1-10
```

---

## Loop Variable Constant

This message occurs if the **For** loop variable was not a variable.

```
for 10 = 1 to 20
```

## Loop Variable Not INT

This message occurs if the **For** loop variable was not an integer.

```
var i : $10 for i = 1 to 10
```

## Max Files Open

This message occurs if an attempt was made to open more than 10 files in a single **Event**.

## Max Include Nesting

This error occurs when include files become nested too deeply. Include files become nested when include files include other include files. For example, `script.isl` may include `file1.isl`, which may include `file2.isl`, and so forth. There is a limit to the depth of files that may be included.

This error can also occur when a file tries to include itself. In this case, the ISL interpreter keeps rereading the file at the point of inclusion and continues until the file is read in 10 times. At this point, an error will be generated before the script has run.

## Max Lines Executed

This message occurs if the *system\_variable* `@MAX_LINES_TO_EXECUTE` was set to a non-zero value and `@MAX_LINES_TO_EXECUTE` command lines were executed.

## Max Macro Keys

This message occurs if the maximum number of defined macro keys was encountered.

```
for i = 1 to 1000
    loadkybdmacro 1 = i
endfor
```

## Max Ref Info

This message occurs if the maximum number of reference lines were issued by the **SaveRefInfo** command. The maximum number of lines is 8.

## Max Window Input Entries

This message occurs if too many **DisplayInput** entries were specified. The maximum number of **DisplayInput** entries is 64.

## Memory Allocation

This message occurs if an internal memory error has occurred.

---

## Must Have List Var

This message occurs if ISL encountered a list specification without a list value.

```
txmsg list[]
```

## Name is a Reserved Word

This message occurs if an attempt was made to declare a variable with the same name as a reserved word.

```
var display : n4
```

## New TNDTTL Exceeds Original

This message occurs if an attempt was made to increase the *system\_variable* @TNDTTL value, but the value can only be decreased.

## No Arrays in Sub Var

This message occurs if a Sub command tried to declare an *array\_variable* in the argument list.

```
sub mysub( var i[ 10 ] : N5 )
```

## No ISL File

This message occurs if the script was not found or did not exist.

## No Match for EndFor

This message occurs if no corresponding **EndFor** command exists for a **For** command.

```
event inq : 1
  for row_cnt = 1 to number_occupants
    display row_cnt, 2, occupant_list[row_cnt]
    .
    .
    .
//Missing endfor command
endevent
```

## No Match for EndWhile

This message occurs if no corresponding **EndWhile** command exists for a **While** command.

```
event inq:1
.
.
.
while i < 10
.
.
.
//No endwhile declared
endevent
```

---

## No Match for Event

This message occurs if the SIM Inquiry and/or SIM Tender key had no corresponding Event Inq or Event\_Tmed.

For example, if the SIM Inquiry Key #920 (SIM Key 1 : Inq 1) is pressed, and Event Inq : 1 does not exist, this message will display.

## No Number in Sys Var

This message occurs if a *system\_variable* requires a number entry after it and no number was entered.

For example, *system\_variable* @SI must have a number 1 - 16 after it.

## No Ops on Strings

This message occurs if the declared string operation is not allowed.

```
a = "123" - "abc"
```

## No PMS Message Received

This message occurs if no response was received from the PMS system after the RxMsg command was executed.

## No Touchscreen Keys Defined

If the script executes a **ClearIslTs** command to clear the ISL-defined touchscreen, then immediately tries to display the ISL-defined touchscreen using **DisplayIslTs** or **PopUpIslTs**, the ISL cannot display the touchscreen because there are no keys to display.

```
event inq:1
  clearislts                               //Remove any defined keys.
  displayislts                             //No keys, error occurs
                                           // here.
endevent
```

## Not a Variable

This message occurs if a variable was expected but not encountered.

```
input 123, "Enter value" //123 not variable
```

## Not Enough Input Data

This message occurs if the @STRICTARGS variable is set and there were too many variables specified in the **RxMsg**, **Split**, **SplitQ**, or **FRead** command.

Assume the following data was received in a PMS message: Dan|Tooher. The message has two fields. The following example expects three fields and would generate the above error:

```
var fname : A20, lname : A20, status : N3
.
.
.
rxmsg fname, lname, status
```

---

## Not Enough List Data

This message occurs if the @STRICTARGS variable is set to a non-zero value, but the input data did not have enough values to assign the specified list.

Assume the following data was received in a PMS message: 3|Smith|Jones. The 3 signifies that three fields follow, and only two fields are present. The following would generate the above error:

```
var size : N3
var list[10] : A20
.
.
.
rxmsg size, list[ ]
```

## Not Enough Variables

This message occurs if the @STRICTARGS variable is set to a non-zero value, but there were not enough variables specified in the **RxMsg**, **Split**, **SplitQ**, or **FRead** command.

Assume the following data was received in a PMS message: **DanTooher**. The message has two fields. The following example expects one field and would generate the above error:

```
var fname : A20, lname : A20, status : N3
.
.
.
rxmsg fname
```

## NUMERIC ENTRY REQUIRED

This message occurs if non-numeric data was entered for a numeric variable.

## Print Already Started

This message occurs if a **StartPrint** command was encountered while print was still active (for example, prior to a corresponding **EndPrint**).

```
startprint @RCPT
printline ...
startprint @CUST
.
.
.
endprint
```

## Print Not Started

This message occurs if a **PrintLine** or **EndPrint** command was encountered without a corresponding **StartPrint** command.

## Reading Ord Dvc Table

This message occurs if an error occurred while reading the Order Devices module in the Enterprise Management Console (EMC).

---

## Reading Tbl Def

This message occurs if an error occurred while reading the Tables module in the EMC.

## Require Array for List

This message occurs if an array was expected but a non-array variable was encountered.

```
var i : N5
listdisplay 1, 2, 3, i           //i is not an array
```

## Script Memory Allocation Error

This message occurs if an internal error is encountered.

## Start Position Invalid

This message occurs if the *start\_position* parameter in the **Mid** command and/or function is invalid.

```
str = mid("abc", -2, 3)           //-2 is invalid
```

## String Overflow

This message occurs if an attempt to assign a value to a string exceeded the string's storage size.

```
var n : A3
n = "message"                   //n only holds 3 characters
```

## Sub Array Ref Invalid

This message occurs if a Sub command had an invalid *array* declaration for an *array\_variable*.

```
sub mysub( ref array[ ] )       //Only one bracket
                                //Should be [ ]
```

## Sub Has No Arguments

This message occurs if a **Call** command was made with arguments, and the subroutine called had no arguments.

```
event inq:1
  call mysub( 1, 2, 3 )
endevent

sub mysub                       //Mysub missing ( 1, 2, 3 )
.
.
.
endsub
```

## Sub Statement in Procedure

This message occurs if a Sub command was encountered while inside an Event.

```
event inq:1
  sub mysub
  .
  .
  .
```

---

```
endsub
endevent
```

## System Variable Declaration

This message occurs if an attempt was made to declare a *system\_variable* (for example, any variable name that begins with the @ character).

```
var @chk : N3
```

## Sys Var Not Assignable

This message occurs if an attempt was made to assign a value to a read-only *system\_variable*.

## Too Few Args in Call

This message occurs if the **Call** command did not have enough arguments.

```
event inq:1
  call mysub( 1 )
endevent

sub mysub( var i:n5, var j:N5 )
  .
  .
  .
endsub
```

## Too Few Arguments

This message occurs if there were not enough arguments specified for a function.

## Too many Args in Call

This message occurs if the **Call** command had too many arguments.

```
event inq:1
  call mysub( 1, 2 )
endevent

sub mysub( var i:n5 )
  .
  .
  .
endsub
```

## Too Many Arguments

This message occurs if too many arguments were specified for a function.

## Too Many Nested Calls

This message occurs if too many subroutines were nested within each other.

## Too Many Touchscreen Keys

The ISL-defined touchscreen will hold a finite number of keys (i.e, nine). If the user tries to define too many keys, this error will occur.

---

```

event inq:1
  var i:n5

  clearislts                                // Remove any defined keys.
  for i = 1 to 100                            // Loop will generate an error.
    setisltskey 1, 1, 2, 1, 1, @key_clear, "CLEAR"
  endfor
displayislts                                // No keys, error occurs here.
endevent

```

## Too Many PMS Definitions Active. Start New Transaction

This message occurs if the following condition occurs: the revenue center PMS link database file must have changed while the User Workstation was in a transaction. To clear this condition, cancel the current transaction.

## Undefined Call

This message occurs if a **Call** was made to a subroutine that did not exist within the script.

## Undefined Function

This message occurs if an undefined function was called.

## Undisplayable Variable

This message occurs if the *variable* cannot be displayed.

```

display 2, 3, @TRDTL                        //@TRDTL cannot be
                                           // displayed

```

## Unexpected Data after Call

This message occurs if the Call command is invalid.

```

call mysub + 3

```

## Unexpected Data after Sub

This message occurs if the Sub command is invalid.

```

sub mysub - 4

```

## Unexpected Data in Sub

This message occurs if the parameter list in the **Sub** command is invalid.

```

sub mysub( var fred:N5, i : N5 )

```

## Unexpected End of Line

This message occurs if not enough data was specified on the command line.

```

display 2, 2,                               //should be data after 2,

```

## Unexpected Token Type

This message occurs if invalid text is encountered when trying to read a command or function.

---

## Unknown Command

This message occurs if an unknown command is specified.

```
display 2, 2, "Line" //display is misspelled
```

## Unknown System Variable

This message occurs if an unknown *system\_variable* is referenced.

```
display 2, 2, @RVVC
```

## Unmatched Endevent

This message occurs if an **Endevent** was encountered without a corresponding **Event** command.

## Unmatched EndFor

This message occurs if a **For/EndFor** nesting error occurred.

## Unmatched If

This message occurs if an **If, ElseIf, Else,** or **EndIf** nesting error occurred.

## Value Not Key Definition

This message occurs if an attempt to use a non-key variable in an expression which required a *key\_variable* was encountered.

```
loadkybdmacro 12.47
```

## Variable Undefined

This message occurs if an undefined *variable* was referenced.

## Window Columns Out of Range

This message occurs if an attempt was made to declare a Window that was too wide.

```
window 4, 1000
```

## Window Has Not Been Defined

This message occurs if an attempt to display text within a **Window** occurred without a Window first being declared.

## Window Rows Out of Range

This message occurs if an attempt was made to declare a Window that was too tall.

```
window 1000, 10
```

---

---

## Appendix B Sample Code

This chapter includes sample code for Oracle Restaurants SIM TCP Server, Sample SIM Server, and a sample makefile.

### Oracle Resturants SIM TCP Server

```
/*
 *      MICROS SIM TCP Server
 *
 *      This code implements a server process which accepts SIM messages
 *      from an Oracle Restaurants POS client process over a TCP link.
 *
 *      This sample code is written for UNIX System V using the AT&T SVID
 *      Transport Layer Interface (TLI) API. It should be easily portable
 *      to the X/Open Transport Interface (XTI). Porting to a
 *      Berkeley-style socket library is left as an exercise for the
 *      reader.
 */

#include <stdio.h>
#include <fcntl.h>
#include <signal.h>
#include <sysexits.h>
#include <sys/types.h>

#include <netdb.h>
#include <tiuser.h>
#include <stropts.h>
#include <arpa/inet.h>
#include <sys/socket.h>
#include <sys/netinet/in.h> extern int terrno.
/* operating-system specific device name: */
#define TCP_DEVICE_NAME    "/dev/inet/tcp"

/* define SIM TCP service: */
#define SIM_SERVICE_NAME  "micros-sim"
#define SIM_SERVICE_TYPE  "tcp"
#define DEFAULT_SIM_PORT  5009

#define      SIM_MAX_MSG    32767
#define      SIM_MAX_MSG_BODY    (32767 - 25    - 4    - 4)

/* supplied by SIM vendor: */
extern void process_pos_request(const char *header,
                               const char *body,
                               char reply_body[SIM_MAX_MSG_BODY]);
```

---

```

/* supplied below: */
static void transfer_pos_messages(int fd);

void run_sim_server(void)
{
    int listen_fd, conn_fd;
    struct sockaddr_in *sin;
    struct servent *servp;
    struct t_bind *bind;
    struct t_call *call;
    u_short serviceport;
    int retries;

/* Open a TCP server endpoint to listen for
 * requests from POS client processes.
 *
 * If the requested address is in use, retry up to 10 times.
 * This can occur if another server was running on the same
 * address, and the TCP port has not yet completed its shutdown
 * processing.
 */

if ((servp = getservbyname(SIM_SERVICE_NAME, SIM_SERVICE_TYPE)) == NULL)
    serviceport = htons(DEFAULT_SIM_PORT);
else
    serviceport = (u_short) servp->s_port;

retries = 10; while
(retries--) {

    if ((listen_fd = t_open(TCP_DEVICE_NAME, O_RDWR, NULL)) < 0) {
t_error("run_sim_server: t_open");
exit(EX_OSFILE);
}

if ((bind = (struct t_bind *)t_alloc(listen_fd, T_BIND, T_ALL))
== NULL) {
t_error("run_sim_server: t_alloc(T_BIND)"); t_close(listen_fd);
exit(EX_OSERR);
}

sin = (struct sockaddr_in *) bind->addr.buf;
sin->sin_family = AF_INET;
sin->sin_addr.s_addr = INADDR_ANY;
sin->sin_port = serviceport;
bind->addr.len = sizeof *sin;
bind->qlen = 1;

```

---

```

if (t_bind(listen_fd, bind, bind) < 0) {
    t_error("run_sim_server: t_bind");
    t_close(listen_fd);
    exit(EX_OSERR);
}
if (sin->sin_port != serviceport) {
    fprintf(stderr, "run_server: wanted port %d, got port %d, retrying\n",
ntohs(serviceport), ntohs(sin->sin_port));
    t_close(listen_fd);
    t_free((char *)bind, T_BIND); sleep(10);
}
else
break;
}

if (retries == 0) {
    fprintf(stderr, "run_sim_server: could not get port %d\n",
ntohs(serviceport));
    t_close(listen_fd);
    exit(EX_TEMPFAIL);
}

if ((call = (struct t_call *)t_alloc(listen_fd, T_CALL, T_ALL)) == NULL)
{
    t_error("run_sim_server: t_alloc(T_CALL)");
    t_close(listen_fd);
    exit(EX_OSERR);
}

/* For simplicity, we ignore SIGCLD, which allows the exiting
*   child processes to clean up after themselves, without
*   requiring the parent (this process) to call wait().
*/ sigignore(SIGCLD);
/* We now have the desired TCP port open.
*   Accept connections, and for each connection accepted,
*   start a server process.
*/

while (1) {

/* Listen for incoming connections.
*   This process will typically spend 99.9% of its time
*   blocked in this t_listen() call.
*/

if (t_listen(listen_fd, call) < 0) {
    t_error("run_sim_server: t_listen"); t_close(listen_fd);
    exit(EX_OSERR);
}
}

```

---

```

/* Open a new endpoint and accept the connection
 *   on this new endpoint (freeing the listen_fd
 *   to accept further connections).
 */

if ((conn_fd = t_open(TCP_DEVICE_NAME, O_RDWR, NULL)) < 0) {
    t_error("run_sim_server: t_open");
    t_close(listen_fd);
    exit(EX_OSFILE);
}

if (t_bind(conn_fd, NULL, NULL) < 0) {
    t_error("run_sim_server: t_bind");
    t_close(conn_fd); t_close(listen_fd);
    exit(EX_OSERR);
}

if (t_accept(listen_fd, conn_fd, call) < 0) {
    if (t_errno == TLOOK) {
        /* retrieve disconnect indication, if any, and continue */
        t_rcvdis(listen_fd, NULL);
        t_close(conn_fd);
    }
    else {
        t_error("run_sim_server: t_accept");
        t_close(conn_fd); t_close(listen_fd);
        exit(EX_OSERR);
    }
}
else {

/* Push the "tirdwr" module onto the connection, establishing
 *   the "read/write" interface This is so the rest of this process
 *   does not have to understand the more complicated TLI scheme
 *   for pushing messages, and can treat this connection just like
 *   a tty. (Let the streams module do the work.)
 *
 *   After this succeeds, no TLI calls can be made on conn_fd,
 *   only read(), write(), and close().
 */

if(ioctl(conn_fd, I_PUSH, "tirdwr") < 0) {
    perror("run_sim_server: ioctl(I_PUSH, tirdwr)");
    t_close(conn_fd);
    t_close(listen_fd);
    exit(EX_OSERR);
}
}

```

---

```

/* Start a child process, which will use conn_fd.
 *   The parent will close conn_fd and return to
 *   listening.  If the fork fails, we will discard
 *   this connection, but continue to listen,
 *   since the situation should clear up eventually.
*/ switch(fork()) {
case -1:      /* error */ perror("run_sim_server: fork"); close(conn_fd);
break;

default:     /* parent */ close(conn_fd); break;

case 0:      /* child */ t_close(listen_fd);
transfer_pos_messages(conn_fd); exit(EX_OK);
break;

}
}
}
}

#define SOH  1
#define STX  2
#define ETX  3
#define EOT  4
#define ACK  6
#define NAK 21

enum SIM_Link_State { sim_msg_begin, sim_msg_id, sim_msg_data,
sim_msg_cksum };

static void transfer_pos_messages(int fd)
{
int i, n;
int msg_buf_len; char *header, *body;
enum SIM_Link_State state; char msg_buf[SIM_MAX_MSG + 1];
char recv_buf[SIM_MAX_MSG + 1]; char reply_buf[SIM_MAX_MSG + 1]; char
reply_body[SIM_MAX_MSG_BODY];

/* Handle input from POS system, implementing the network protocol:

 *   1. Attempt to read bytes from POS connection, blocking.
 *   2. If an invalid message is received, discard it.
 *   3. When a complete message is available, call
 *   process_pos_request,
 *   passing the received header, the received body,
 *   and a buffer for the reply.

```

---

```

*      4. When process_pos_request returns, reply to the POS
*      connection with a copy of the received header and
*      the reply buffer returned from process_pos_request.
*/

state = sim_msg_begin; msg_buf_len = 0;

#define NEXT_STATE(prev,next) (state == (prev) \
? (state = (next), 1) \
: (state = sim_msg_begin, 0))

#define STATE_ERROR {      msg_buf_len = 0; state = sim_msg_begin; }
while (1) {
n = read(fd, recv_buf, SIM_MAX_MSG);

if (n < 0 && errno == EINTR)
    continue; /* ignore interrupts, read again */

if (n < 0) { perror("transfer_pos_messages: read");
    close(fd); /* this connection is finished */ return;
}

if (n == 0) {
    fprintf(stderr, "transfer_pos_messages: connection closed\n");
    close(fd); /* this connection is finished */
    return;
}

for(i = 0; i < n; i++) { switch(recv_buf[i]) {
case SOH:
if(NEXT_STATE(sim_msg_begin, sim_msg_id)) {
/* Restart message, and, for clarity,
*      remember the position of the (upcoming) first
*      byte of the header.
*/
msg_buf_len = 0;
header = &msg_buf[msg_buf_len];
}
else
    STATE_ERROR
break;

case STX:
if(NEXT_STATE(sim_msg_id, sim_msg_data)) {
/* NUL-terminate header, and remember the position
* of the (upcoming) first byte of the body
*/
msg_buf[msg_buf_len++] = '\0'; body = &msg_buf[msg_buf_len];
}

```

---

```

else
STATE_ERROR
break;

case ETX:
if (NEXT_STATE(sim_msg_data, sim_msg_cksum)) {
/* NUL-terminate the body. */ msg_buf[msg_buf_len++] = '\0';
}
else
STATE_ERROR
break;

case EOT:
if(NEXT_STATE(sim_msg_cksum, sim_msg_begin)) {

int reply_len; reply_body[0] = '\0';
/* If body exists,
* send request to SIM-specific code.
* header[0] through NUL is the header.
* body[0] through NUL is the request body.
* reply_body[0] through NUL will be the reply body.
* (If body is empty, return empty response to POS.)
*/

if (body[0] != '\0')
process_pos_request(header, body, reply_body);

/* Frame original header and reply body,
* and respond to the POS system.
*/

sprintf(reply_buf, "%c%s%c%s%c%c",
SOH, header, STX, reply_body, ETX, EOT);
reply_len = strlen(reply_buf);
if (write(fd, reply_buf, reply_len) != reply_len) {
perror("transfer_pos_messages: write"); close(fd);
return;
}

}
else
STATE_ERROR
break;

case ACK: case NAK:
/* Ignore ACKs and NAKs */ break;

default: switch(state) {
case sim_msg_begin: case sim_msg_cksum: default:

```

```

break;
case sim_msg_id: case sim_msg_data:
msg_buf[msg_buf_len++] = recv_buf[i]; break;
break;
}
break;

}
}
}
}

```

## Sample SIM Server

```

/*
 *
 * This code is a complete implementation of a SIM server,
 * demonstrating the functions which must be provided by
 * the server application.
 *
 * This example sends valid responses to Symphony-standard format POS messages.
 */
extern void run_sim_server(void); main()
{
    run_sim_server();
}

void process_pos_request(const char *header,
const char *body,
char reply_body[])
{
    printf("Header = %s\n", header);
    printf("Body = %s\n", body);
    if (body[0] == '1' && body[1] == '1')
        strcpy(reply_body, " 1ABCDEFGHIJKLMN0P");
    else if (body[0] == '2' && body[1] == '2')
        strcpy(reply_body, " 2ZYXWVUTSRQPONMLK");
    else
        strcpy(reply_body, "///UNKNOWN REQUEST");

    printf("Reply Body = %s\n", reply_body);
}

```

## Sample Makefile

```

Simtest: Simtest.o Sirmsrv.o
    cc -o simtest simtest.o simsrv.o -lsocket -lnsl_s -lc_s

simtest.o: simtest.c
    cc -c -W2 -strict -g simtest.c

sirmsrv.o: simsrv.c
    cc -c -W2 -strict -g simsrv.c

```

---

---

# Appendix C ISL Quick Reference

This chapter is a quick reference guide to the syntax of all ISL language elements, including data types, operators, system variables, format specifiers, commands, and functions.

## Data Types

Table 145 Data Types

Data Type	Abbreviation	Description	Example
Numeric	Nx	These variables are used for numeric information and may comprise <i>x</i> digits (integers, not decimal), for example, N4 supports -9999 to 9999.	var rowcnt : n3
Decimal	\$x	These variables are used for decimal amounts. Operator entries will assume a decimal place according to the currency's default setting, as specified in the <i>Currency</i> module; for example, entering 1234 in the US will result in an amount of 12.34. They may comprise <i>x</i> digits, (for example, \$4 in the US will support -99.99 to 99.99).	var new_ttl : \$12
Alphanumeric	Returns the ASCII integer value of the first character of the string	These variables may include any non- control character, including punctuation marks. They may comprise <i>x</i> characters.	var name : a20
Key	key	This system variable is used for key press variables.	var keypressed : key

# Relational and Logical Operators

## Unary Operators

Table 146 Unary Operators

Operator	Description	Example
-	Negation operator (a minus sign). This is used to negate an expression.	-3  -count
NOT	Will negate the result of the expression. The NOT operator can be applied to expressions in the same way as the unary minus operator.	The NOT operator will negate the result of the expression. For example, the following expression is always TRUE:  ( 3 < 4 )  The NOT operator will negate the sense of the above expression; thus, the following expression is always FALSE:  NOT ( 3 < 4 )

## Binary Operators

Table 147 Binary Operators

Operation	Operator	Allowable Operand Types: Nx, \$x, and Ax
multiplication	*	Nx, \$x Ax, Key
division	/	Nx, \$x
modulus	%	Nx, \$x
plus	+	Nx, \$x
minus	-	Nx, \$x
bit-wise and	&	Nx
bit-wise or		Nx
equality	=	Nx, \$x Ax, Key
greater than or equal	>=	Nx, \$x, Ax, Key

Operation	Operator	Allowable Operand Types: Nx, \$x, Ax, and Key
greater than	>	Nx, \$x, Ax, Key
less than or equal	<=	Nx, \$x, Ax, Key
inequality	<>	Nx, \$x, Ax, Key
less than	<	Nx, \$x, Ax, Key
logical and	AND	Nx
logical or	OR	Nx

## C-System Variables

Table 148 System Variables

Category	Variable Name and Syntax	Field/Parameter
Cover/Guest Count	@GST	Guest Count
Data Entry	@FIELDSTATUS	Data Entry Field Status Flag
	@INPUTSTATUS	User Input Status Flag
	@MAGSTATUS	Magnetic Card Entry Status Flag
	@RETURNSTATUS	Transaction Item Return Indicator
	@USERENTRY	Data Entered Before SIM Inquiry Key Activated
	@VOIDSTATUS	Transaction Item Void Indicator
Date and Time	@DAY	Current Day of Month
	@EPOCH	EPOCH Time
	@HOUR	Current Hour of Day
	@MINUTE	Current Minute
	@MONTH	Current Month
	@SECOND	Current Second
	@WEEKDAY	Day of Week
	@YEAR	Current Year
Discount/Service Charge Employee	@AUTOSVC	Auto Service Charge
	@CHGTIP	Charged Tip
	@DSC	Discount Total

Category	Variable Name and Syntax	Field/Parameter
	@DSC_OVERRIDE	When a manual discount is entered, a SIM 'Discount' script
	@DSCI	Discount Itemizer
	@EMPLDISCOUNT	In a discount event, this variable is the number of the employee discount
	@EMPLDISCOUNTEMPL	In a discount event, this variable is the employee number of the discount receiving the employee
	@NUMDSC	Active Discounts
	@NUMSVC	Active Service Charges
	@SVC	Service Charges
	@SVC I	Service Charge Itemizer
	@CKEMP	Check Employee
	@EMPLOPT[]	SIM ISL Options #1-#8
	@TRAININGMODE	Training Mode Status Flag
	@TREMP	Transaction Employee
Event Data	@EVENTID	ID of event being raised
	@EVENTTYPE	Type of event being raised
	@OBJ	Object number of detail item
	@PICKUPLOAN	Value of pickup or loan amount
	@QTY	Quantity of detail item
	@TTL	Amount of detail item
File I/O	@FILE_BFRSIZE	User Definable Variable
	@FILE_ERRNO	Standard Error Number Value
	@FILE_ERRSTR	Standard Error String based on @FILE_ERRNO
	@FILE_SEPARATOR	Field Separator for File I/O Operations
Function Keys	@KEY_CANCEL	Cancel Key
	@KEY_CLEAR	Clear Key
	@KEY_DOWN_ARROW	Arrow Down Key
	@KEY_END	End Key
	@KEY_ENTER	Enter Key

Category	Variable Name and Syntax	Field/Parameter
	@KEY_EXIT	Exit Key
	@KEY_HOME	Home Key
	@KEY_LEFT_ARROW	Arrow Left Key
	@KEY_PAGE_DOWN	Page Down Key
	@KEY_PAGE_UP	Page Up Key
	@KEY_RIGHT_ARROW	Arrow Right Key
	@KEY_UP_ARROW	Arrow Up Key
Guest Check	@CHK_OPEN_TIME	Date and Time Check Opened
	@CHK_OPEN_TIME_T	Current Check Open Time
	@CHK_PAYMNT_TTL	Current Check Payment Total
	@CHK_TTL	Current Check Total
	@CHECKDATA	Facsimile of Check
	@CKCSHR	Cashier Number
	@CKID	Check ID
	@CKNUM	Check Number
	@LASTCKNUM	Last Check Number Assigned to Guest Check
	@TRCSHR	Transaction Cashier Number
Open Check	@NUM_OPENCHECKS	Lists Open Checks per Revenue Center
Order Type	@ORDERTYPE	Order Type
Printing	@CHK	Guest Check Printer
	@DWOFF	Double-wide Characters OFF
	@DWON	Double-wide Characters ON
	@HEADER	Guest Check, Receipts, Credit Card Vouchers
	@NUL	Specifies a binary 0 should be
	@ORDR[]	Remote Order or Local Order
	@PRINTSTATUS	Print Status Flag
	@RCPT	Customer Receipt Printer
	@REDOFF	Red Ink OFF
	@REDON	Red Ink ON
	@TRAILER	Guest Check, Receipts, Credit Card Vouchers
	@VALD	Validation Chit Printer

Category	Variable Name and Syntax	Field/Parameter
Property Management System (PMS)	@OFFLINELINK	Used to link to an offline PMS
	@PMSLINK	Revenue Center PMS Link
	@PMSNUMBER	PMS Object Number
	@RXMSG	Name of PMS Response Message
	@SIMDBLINK	Links to the SIMDB DLL to the database
Proration	@GSTRMNG	Guests Remaining after Proration
	@GSTTHISTENDER	Guest Count Associated with Split Tender
Sales Itemizer	@NUMSI	Active Sales Itemizers
	@SI[]	Sales Itemizers
	@TXBL[]	Taxable Sales Itemizers
Sales Total	@CHANGE	Change Due
	@PREVPAY	Previous Payment
	@TNDTTL	Tender Total
	@TTLDUE	Total Due
Script	@RANDOM	Returns a random value between 0 and 232-1
	@RVC	Revenue Center Number
	@WARNINGS_ARE_FATAL	Strong Checking
Seat	@SEAT	Active Seat Number
Serving Period	@SRVPRD	Serving Period
System	@DBVERSION	Current Database Version
	@GUID	The GUID of the Current Check
	@OS_PLATFORM	1 - Windows® CE 3 - Win 32
	@PLATFORM	Hardware Platform
	@PROPERTY	The Property Number of the Workstation
	@SYSTEM_STATUS	Shell Return Status
	@VERSION	SIM Version Number
Table	@GRPNUM	Table Group Number
	@TBLID	Table ID
	@TBLNUM	Table Object Number

Category	Variable Name and Syntax	Field/Parameter
Tax	@NUMTAX	Active Tax Rates
	@TAX[]	Tax Collected
	@TAXRATE[]	Tax Rate
	@TAXVAT[ ]	Returns the Value Added Tax Amount for Tax Rate "X"
	@TXEX_ACTIVE[ ]	Checks if the Tax is Exempt at the Specified Level
Tender/Media	@TMDNUM	Tender/Media Number
Touchscreen	@ALPHASCREEN	Alpha Touchscreen
	@NUMERICSCREEN	Numeric Touchscreen
Transaction Detail	@DETAILSORTED	Detail Sorting Status
	@DTL_DEFSEQ[]	Definition Sequence of Detail Item
	@DTL_DSC_EMPL[ ]	Employee who is getting the employee meal discount for the specified detail entry
	@DTL_DSCI[ ]	Menu Item Detail Class Discount Itemizer Value
	@DTL_FAMGRP[]	Menu Item's Family Group
	@DTL_INDEX	Index of the detail which fired the SIM event
	@DTL_IS_COND[i]	Determines if a Guest Check Menu Item is a condiment
	@DTL_MAJGRP[]	Menu Item's Major Group
	@DTL_MLVL[]	Main Menu Level of Detail Item
	@DTL_NAME[]	Name of Detail Item
	@DTL_OBJNUM[]	Object Number of Detail Item
	@DTL_PLVL[]	Price Level of Detail Item
	@DTL_PMSLINK[]	PMS Link of Detail Item
	@DTL_PRICESEQ[]	Price Sequence Number of Detail Item
	@DTL_QTY[]	Quantity of Detail Item
	@DTL_SEAT[]	Seat Number of Detail Item
	@DTL_SLSI[ ]	Menu Item Detail Class Sales Itemizer Value
@DTL_SLVL[]	Sub-menu Level of Detail Item	
@DTL_STATUS[]	Status of Detail Item	
@DTL_SVC_LINK[ ]	Stored Value Card Link	

Category	Variable Name and Syntax	Field/Parameter
	@DTL_SVC_TYPE[ ]	Stored Value Card Type
	@DTL_TAXTTL[ ]	Returns the Tax Total of Detail Item
	@DTL_TAXTYPE[]	Tax Types
	@DTL_TTL[]	Total of Detail Item
	@DTL_TYPE[]	Type of Detail Item
	@DTL_TYPEDEF[ ]	Returns the Detail Item Type Definition
	@MAXDTLR	Maximum Size of @TRDTLR
	@MAXDTLT	Maximum Size of @TRDTLT
	@NUMDTLR	Number of Detail Entries this Service Round
	@NUMDTLT	Number of Detail Entries for Entire Transaction
Troubleshooting	@LINE	Current Line Executed in Script
	@LINE_EXECUTED	Lines Executed in Script
	@MAX_LINES_TO_RUN	Maximum Lines of Script to Execute
	@PMSBUFFER	PMS Message
	@TRACE	Output Line of Script to 8700d.log
Window	@CENTER	Center Column in ISL-defined window
	@WCOLS	Number of Columns in ISL-defined window
	@WROWS	Number of Rows in ISL-defined window
Workstation	@WSID	Workstation ID number
	@WSTYPE	User Workstation Type
	@WSSUBTYPE	Use Workstation Subtype

# Format Specifiers

## Input Specifiers

Table 149 Format Specifiers

Input Specifier	Description
-	Data being typed in by the operator should not be echoed back to the display For example: Input <code>auth_code{-}</code> , "Enter authorization code"
$Mn,^*$	Specify the track number ( $n = 1$ or $2$ ) and what data to read from the magnetic card. For use with the <b>Input</b> , <b>InputKey</b> , <b>DisplayInput</b> , and <b>DisplayMSInput</b> commands only. The M character is case-insensitive For example: Input <code>auth_code{ M2,* }</code> , "Enter authorization code"
$Mn, field, start, count   ^*$	$Mn$ : the track number (M1 or M2); this can be followed by a star (*) to specify all fields on the track, or use the following fields to read specific information:  <i>field</i> : the field position within the specified track; this is a positive integer.  <i>start</i> : starting offset (character) within the field; for example, if one wants to take the last four characters of the "Blaine Richard" string, the offset would start at 11.  <i>count</i> : number of characters to be read from the <i>start</i> (first character) to the end of the <i>field</i> (place an asterisk * to include all characters) For example: Input <code>auth_code{ M2,1,3,10 }, \</code> "Enter authorization code"

## Output Specifiers

The proper syntax for using the *output\_specifiers* is as follows:

`<|>|* [ + ] [ 0 ] [ size ] [ D | X | O | B ] [ ^ ] [ " ] [ :format_string ]`

Output specifiers must also be placed in the order listed in the following table:

**Table 150 Output Specifiers**

<b>Output Specifier</b>	<b>Description</b>
<	Left justification; the <i>size</i> specifier may be used to specify the size of the field.
=	Center justification: the <i>size</i> specifier may be used to specify the size of the field.
>	Right justification: the <i>size</i> specifier may be used to specify the size of the field.
*	Trim leading and trailing spaces; the <i>size</i> specifier may be used to specify the size of the field.
+	Place sign at the start of the field.
0	Pad with zeroes (as opposed to spaces).
<i>size</i>	Where <i>size</i> is the number of the characters in the required field. The <i>size</i> must be a positive integer or an expression that is a positive integer.
D	Decimal (Default); display numerics in decimal format.
X	Hexadecimal; display numerics in hexadecimal format.
O	Octal; display numerics in octal format.
B	Binary; display numerics in binary format.
^	Place a space on each side of the data to be displayed.
"	Place double quotes around the data to be displayed.
<i>:format_string</i>	Like the BASIC language PRINT USING command. All characters will be displayed except for the # character, which will be replaced by characters from the variable or expression preceding the format specifier.

## Commands

Note that:

- All arguments enclosed in brackets [ ] are considered optional.
- The meaning of the data within the braces will be explained later.

**Table 151 Commands**

<b>Category</b>	<b>Command and Syntax</b>	<b>Description</b>
Communications	<b>GetRxMsg</b>	Wait for a PMS message.
	<b>ReTxMsg</b>	Retransmit a message.

Category	Command and Syntax	Description
	<b>RxMsg</b> user_variable or list_spec[, user_variable or list_spec...	Define the format of a message received over the interface.
	<b>TxMsg</b> expression[ <i>{output_specifier}</i> ][,]	Define the format and send an interface message.
	<b>TxMsgOnly</b> <i>expression</i> [ <i>{output_specifier}</i> ][, <i>expression</i> [ <i>{output_specifier}</i> ] \...]	Send a message to a PMS without waiting for a response.
	<b>Use[Compat/ISL]Format</b>	Use Symphony-standard or ISL message format.
	<b>Use[ISL/STD]TimeOuts</b>	Use ISL time outs or the standard Symphony error messaging, when there is no response from the PMS System.
	<b>WaitForRxMsg</b> [prompt_expression[ <i>{output_specifier}</i> ]\ \ [, prompt_expression[ <i>{output_specifier}</i> ]]...]	Wait for an interface message to be received after a TxMsg has been sent. If no prompt text is supplied, Please Wait-Sending Message is the
File I/O	<b>FClose</b> file_number	Close a file.
	<b>FGetFile</b> file_number	Gets a file from the SIM file service.
	<b>Flock</b> file_number, <b>Preventwrite</b> [ <b>And</b> ] [ <b>Preventread</b> ] [ <b>and</b> ] [ <b>Nonblock</b> ]	Lock a file.
	<b>FOpen</b> file_number, file_name, mode	Open a file.
	<b>FPutFile</b> file_number	Puts a file into the SIM file service server.
	<b>FRead</b> file_number, user_variable or list_spec[, user_variable or list_spec...]	Split the next line read from a file into the variables specified in the statement.
	<b>FReadBfr</b> file_number, data, count_to_read, count_read	Read the number of bytes specified in the command.

Category	Command and Syntax	Description
	<b>FReadLn</b> file_number, line	Read the entire line into a string variable.
	<b>FSeek</b> file_number, seek_position	Go to a specified position in an open file.
	<b>FunLock</b> file_number	Unlock a locked file.
	<b>FWrite</b> file_number, variable1 [, variable2][, variable3...]	Write to a formatted file.
	<b>FWriteBfr</b> file_number, data, count_to_write, count_written	Write a specified number of bytes.
	<b>FWriteLn</b> file_number, line	Write an entire line.
Flow Control	<b>Break</b>	Break out of the current For loop.
	<b>Call name</b>	Call a subroutine
	<b>ContinueOnCancel</b>	Continue processing the script even if the [Cancel] or [Clear] key is pressed after an Input command
	<b>Event Inq</b> : number <ul style="list-style-type: none"> <li>• <b>Tmed</b> : number</li> <li>• <b>RxMsg</b> : event_ID</li> <li>• <b>Final_Tender</b> : no event_ID required</li> <li>• <b>Print_Header</b> : alpha/numeric</li> <li>• <b>Print_Trailer</b> : alpha/numeric</li> </ul> <b>..EndEvent</b>	Indicate the start and end of an event procedure.
	<b>ExitCancel</b>	Exit a script and cancel the current tendering
	<b>ExitContinue</b>	Exit a script and continue the current tendering
	<b>ExitOnCancel</b>	Exit a script when the [Cancel] or [Clear] key is pressed after an Input command has been issued.
	<b>ExitWithError</b>	Display a defined error message and exit the script.

Category	Command and Syntax	Description
	<b>For...EndFor</b> counter = start_expression To end_expression [Step increment]	Perform commands a specified number of times.
	<b>ForEver...EndFor</b>	Perform commands an indefinite number of times.
	<b>If...Else...EndIf</b> expression [operator...] expression [operator...]	Execute commands if the specified condition is met.
	<b>Return</b>	Return from a subroutine.
	<b>Sub...EndSub</b> name <b>Sub...EndSub</b> name ( Ref   Var parameter [, Ref   Var parameter]... )	Indicate the start and end of a subroutine procedure.
	<b>TimerSet</b>	Sets a recurring time event.
	<b>TimerReset</b>	Resets a specific timer.
	<b>TimerResetAll</b>	Resets all timers.
	<b>While...EndWhile</b> expression	Execute a loop structure until an expression becomes FALSE.
Input/Output	<b>Beep</b>	Sound the beeper.
	<b>ClearChkInfo</b>	Clear check information detail lines in buffer.
	<b>ClearIsITs</b>	Clear any previously defined touchscreen keys.
	<b>ClearKybdMacro</b>	Clear macro key
	<b>ClearRearArea</b>	Clear the contents of the customer display.
	<b>ClearWaitPrompt</b>	Display a wait prompt.
	<b>Display</b> row, column, expression[{output_specifier}][ expression [{output_specifier}]...]	Display text or a field at a defined place within a window.
	<b>DisplayInput</b> row, column, input_variable[{input/output_specifier}, \ prompt_expression][, prompt_expression,...]	Display an input field within a window.
	<b>DisplayInverse</b> row, column, expression[{output_specifier}][, expression \ [{output_specifier}]...]	Display input field in inverse video.

Category	Command and Syntax	Description
	<b>DisplayIslTs</b>	Display an ISL-defined touchscreen.
	<b>DisplayMSInput</b> row, column, input_variable) \ [{input/output_specifier}], \ prompt_expression[, row, column, \ input_variable{input/	Display an input field within a window and allow magnetic card swipe to satisfy field entry.
	<b>DisplayRearArea</b>	Display up to 20 characters
	<b>ErrorBeep</b> expression{output_specifier}[, expression[{output_specifier}],...]	Sound an error beep.
	<b>ErrorMessage</b>	Display an error message and continue.
	<b>GetEnterOrClear</b>	Wait for the [Enter] or [Clear] key to be pressed.
	<b>GetTime</b>	Retrieve current time.
	<b>Input</b>	Capture operator entry for a single field or prompt.
	<b>Inputkey</b>	Capture operator entry and a key for a single field or prompt.
	<b>ListDisplay (W)</b>	Display a list.
	<b>ListInput (W)</b>	Display a list and get an operator selection.
	<b>ListInputEx</b>	Display a list and get an operator selection. Does not provide a WROW or WCOL variable.
	<b>LoadDbKybdMacro</b>	Load a pre-defined keyboard macro so that it may be executed upon successful completion of a
	<b>LoadKybdMacro</b>	Load a user-defined keyboard macro so that it
	<b>PopUpIslTs</b>	Display a touchscreen as a pop-up.
	<b>Prompt</b> expression[{output_specifier}] [, expression[{output_specifier}],...]	Display an operator prompt.

Category	Command and Syntax	Description
	<b>SaveChkInfo</b> expression[ <code>{output_specifier}</code> ]	Insert check information detail into the check.
	<b>SetIsITsKey</b> row, col, num_rows, num_cols, font, key_expression,	Define a touchscreen key.
	<b>WaitForClear</b> [prompt_expression[ <code>{output_specifier}</code> ]] [, prompt_expression\ [ <code>{output_specifier}</code> ]],...] ]	Wait for the [Clear] key before continuing. If no prompt text is supplied, "Press Clear to Continue" is the default.
	<b>WaitForConfirm</b> [prompt_expression[ <code>{output_specifier}</code> ]] [, prompt_expression\ [ <code>{output_specifier}</code> ]],...] ]	Wait for an operator confirmation. If no prompt text is supplied, "Press Enter to Continue" is the default.
	<b>WaitForEnter</b> [prompt_expression[ <code>{output_specifier}</code> ]] [, prompt_expression\ [ <code>{output_specifier}</code> ]],...] ]	Wait for the [Enter] key before continuing. If no prompt text is supplied, "Press Enter to Continue" is the default.
	<b>WaitPrompt</b>	Display a wait prompt.
	<b>Window</b> row, column [, expression[ <code>{output_specifier}</code> ]],...] ]	Create a window of specified size and optionally display a window title.
	<b>WindowClose</b>	Close the current window.
	<b>WindowEdit</b> [WithSave]	Display the current contents of specified variables within a window and allow them to be edited; optionally require the [Save] key to save entries and exit.
	<b>WindowInput</b> [WithSave]	Display the specified fields within a window, without the present contents; optionally require the [Save] key to save entries and exit.
Miscellaneous	<b>LowerCase</b>	Convert a string to lower-case.

Category	Command and Syntax	Description
	<b>MSleep</b> <i>milliseconds</i>	Sleep for the requested number of milliseconds.
	<b>UpperCase</b>	Convert a string to upper-case.
	<b>UseBackupTender</b>	Use backup tender programmed in the Symphony database.
Printing	<b>LineFeed</b> [number_of_line_feeds]	Linefeed one or multiple lines.
	<b>ListPrint</b> list_size, array	Print a list.
	<b>PrintLine</b> expression[{output_specifier}] or directive \ [, expression[{output_specifier}] or directive...]	Print specified text and/or fields.
	<b>PrintSimFeatures</b>	Print all SIM features available in the current SIM engine.
Variables	<b>ClearArray</b> array_variable	Clear an array
	<b>Format</b> string_variable [, field_sep_char] as expression[{{output_specifier}},\ expression[{output_specifier}],...]	Concatenate one or more variables into a string.
	<b>FormatBuffer</b> source_string, destination_string	Format a non-printable string into a printable string.
	<b>FormatQ</b> string_variable [, field_sep_char] as expression[{output_specifier}},\ expression[{output_specifier}],...]	Concatenate one or more variables into a string and enclose the string in quotes.
	<b>MakeAscii</b> source_string, destination_string	Remove any non-ASCII characters from a string.
	<b>Mid</b> (string_variable, start, length) = replacement_string	Set one portion of a string equal to another string.
	<b>ProRate</b>	Prorate itemizers for chg posting.
	<b>[Retain/Discard]GlobalVar</b>	Retain or discard global variables between transactions.

Category	Command and Syntax	Description
	<b>SaveRefInfo</b> expression[ <i>{output_specifier}</i> ] [, expression \ <i>{output_specifier}</i> ,...]	Save information as tender/ media reference detail.
	<b>SaveRefInfo</b> <i>ref_type</i> , expression[ <i>{output_specifier}</i> ] [, expression \ <i>{output_specifier}</i> ,...]	Save information as tender/ media reference detail with reference type.
	<b>SetReRead</b>	Re-read the ISL script for new or changed ISL scripts.
	<b>SetSignOn[Left/Right]</b>	The minus sign will go on the left or right side, respectively, when formatting numbers.
	<b>SetString</b> <i>main_string</i> , <i>character_string</i> [, <i>count</i> ]	Replace all or a specific number of characters in a string with a particular character.
	<b>Split</b> <i>string_to_split</i> , <i>field_sep_char</i> , <i>user_variable</i> or <i>list_spec</i> \ [, <i>user_variable</i> or <i>list_spec</i> ...]	Break a string into separate fields.
	<b>SplitQ</b>	Break a string into separate fields and enclose the string in quotes.
	<b>UseSortedDetail</b>	Consolidated detail is accessible.
	<b>UseStdDetail</b>	Raw detail is accessible.
	<b>Var</b>	Declare a variable field of specified type that will be used for input and/or used in an interface message.

## Functions

Table 152 Functions

Command Name	Syntax
Abs	Abs ( <i>integer</i> or <i>decimal</i> )
ArraySize	ArraySize ( <i>array_name</i> )

Asc	Asc ( <i>string_expression</i> )
Bit	Bit ( <i>hex_string, bit_position</i> )
Chr	Chr ( <i>integer</i> )
CommandExists	CommandExists ( <i>string</i> )
DefKey	
Env	Env ( <i>environment_variable</i> )
Feof	Feof ( <i>file_number</i> )
FormatCheckData	FormatCheckData ( <i>integer</i> )
FormatCurrentDate	FormatCurrentDate ( <i>string</i> )
FormatStr	FormatStr ( <i>format,value1,value2</i> )
FormatValue	FormatValue ( <i>value,string</i> )
FTell	FTell ( <i>file_number</i> )
GetHex	GetHex ( <i>hex_string</i> )
GetValue	FormatValue ( <i>key,string</i> )
Instr	Instr ( <i>index, string_expression, character</i> )
Key	Key ( <i>key_pair</i> )
KeyNumber	KeyNumber ( <i>key_expression</i> )
KeyType	KeyType ( <i>key_expression</i> )
Len	Len ( <i>string_expression</i> )
Mid	Mid ( <i>string_expression, start, count</i> )
SplitString	FormatValue ( <i>value,string</i> )
Str	Str ( <i>value</i> )
SystemVariableExists	SystemVariableExists ( <i>string</i> )
ToInteger	ToInteger ( <i>decimal</i> )
Trim	Trim ( <i>string_expression</i> )
TypeOf	TypeOf ( <i>value</i> )
VarExists	VarExists ( <i>string</i> )
VarSize	VarSize ( <i>user_variable</i> )

---

---

# Appendix D Windows DLL Access

This chapter describes Windows DLLs and how to access them using SIM.

## Windows DLL Access

### Overview

This document describes DLLs and how to access them using SIM. This information is broken down into the following sections:

- What is a DLL?
- Using DLLs
- Symphony SIM DLL Support
- Using Symphony SIM DLL Commands

### What is a DLL?

The Symphony System Interface Module (SIM) can use Microsoft Windows® Dynamic Link Libraries (DLLs). DLLs are modules that contain functions and data. They provide a way of separating applications into small manageable pieces that can be easily modified and reused.

### Dynamic Linking

Dynamic linking provides a means of giving applications access to function libraries at run-time. DLLs are not copied into an application's executable files. Instead, they are linked to an application when it is loaded and executed.

Dynamic link libraries reside in their own separate files. Applications load them into memory when they are needed and share a single copy of the DLL code in physical memory. A single DLL can be used by several applications simultaneously. This in turn saves memory and reduces swapping.

Windows allows only a single instance of a DLL to be loaded into memory at any time. When a DLL is being loaded, Windows checks all the modules already in memory. If it doesn't find a match, then it loads the DLL. If it does find a match, and the matching module is a DLL, it doesn't load it again.

The following are steps that an application takes when calling a function in a DLL:

- The application uses the `LoadLibrary` or `LoadLibraryEx` function to load the DLL at run-time. This, for example, can be a .DLL or .EXE.
- The application calls the `GetProcAddress` function to get the addresses of the exported DLL functions and it is mapped into the address space of the calling process.
- The application then calls the exported DLL functions using the function pointers returned by `GetProcAddress`.

DLLs can define two kinds of functions: exported and internal. The exported functions can be called by other applications. Internal functions can only be called from within the

---

DLL where they are defined. DLLs can contain code, data, and resources such as bitmaps, icons, and cursors. These are stored as executable programs.

## Using DLLs

DLLs are used for three general purposes:

- Sharing components
- Encapsulating (hiding) data and code
- Performing system-level operations

## Sharing Components

DLLs provide an easy way for multiple applications to share components. These components can be:

- Code: a DLL provides one copy of its code for all applications that need it.
- Data: by storing and retrieving data, applications can communicate with each other. The DLL provides a function for applications to store and retrieve data in its data segment.
- Custom Controls: these can be placed in DLLs for use by multiple applications. They can be written by developers and marketed as separate DLLs or used in applications.
- Resources: icons, bitmaps, fonts, and cursors can be placed in DLLs. Device drivers are also DLLs that provide system resources.

## Encapsulating (hiding) Data and Code

DLLs can be used to hide data and code. A DLL can implement an abstract data type (ADT), which can be used by applications. The applications can use the ADT without knowing anything about the actual implementation. When changes are made to the data structures and internal code, the applications that use the DLL don't have to be modified or recompiled.

## Performing System-level Operations

DLLs can be used to perform low-level operations. Operations such as interrupt service routines can be placed in fixed-code segments of DLLs. If an application needs to issue interrupts, the code can be placed in a DLL rather than in the application. Also, a DLL can be written as a device driver for certain pieces of hardware (for example, a mouse or keyboard).

## Simphony SIM DLL Support

The Simphony System Interface Module allows the programmer to reap the benefits of DLLs. The programmer can write or use existing DLLs to further enhance the capabilities of the Simphony POS Operations module. Using three SIM commands, the programmer can create a SIM script to access and externally created DLL. This functionality considerably broadens the scope of the Simphony SIM feature. Some advantages of this feature are:

- The ability to write SIM scripts to customize the Simphony PMS interface.
- The opportunity to take advantage of third-party development.

- 
- A wider range of creativity.
  - Faster turnaround time.

### **Customization**

Using DLLs allows the flexibility of customization. Now the programmer is no longer confined to the text based window that SIM uses for input and output. For example, one could create a custom interface to a PMS that returns guest information to the Symphony POS Operations module.

### **Third-party Development**

If the programmer is not interested in writing DLLs, one can take advantage of DLLs that can be, or already have been, written by a third party for Symphony SIM.

### **Creativity**

Using the resources available with DLLs, fonts, bitmaps, cursors, etc. can be used to create appealing user interfaces.

### **Faster Turn Around Time**

Using DLLs can increase the turn around time of certain system requests. For example, a DLL can be created to connect to the Symphony database and perform a custom query on guest check information.

DLLs allow virtually unlimited flexibility when creating scripts to enhance the functionality of the POS Operations module.

## **Using Symphony SIM DLL Commands**

Three commands allow SIM to access DLLs. They enable a SIM script to call an externally created DLL. These three commands are:

- `DLLLoad`: loads the external DLL
- `DLLCall`: calls a function contained in the DLL
- `DLLCallW`: calls a function contained in the DLL with Unicode
- `DLLFree`: frees a loaded DLL

### **DLLLoad**

The `DLLLoad` command is used to load the external DLL. It needs to be called only once during the lifetime of the SIM script. The syntax is:

```
DLLLoad handle, name
```

Where `handle` is a SIM N9 variable, and `name` is a SIM string expression. The 'name' parameter is used to identify the DLL, and the resulting handle is stored in the 'handle' variable. An example of this would be:

```
var dll_handle:N9
DLLLoad dll_handle, "myops.dll"
```

If the command fails, then `dll_handle` will be 0. If not, then `dll_handle` is the handle used for any further accesses for the other DLL functions.

This function is just a wrapper around the Windows `LoadLibrary()` function. All the rules which apply to path settings apply here.

If the DLL is already loaded, then Windows will prevent it from being loaded again.

---

## DLLCall

The `DLLCall` command is used to call a function contained in the DLL. The syntax for this command is:

```
DLLCall handle, dll_name( [parm1 [parm2 [parm3...]] ] )
```

Where `handle` is the previously loaded library handle, `dll_name` is the name of the function, and `parm#` are the optional parameters.

This command performs two tasks:

- Get the address of the function using the Windows `GetProcAddress()` function. If this function fails, then an ISL error is generated.
- Call the DLL function.

Since it is not possible for SIM to check the validity of the parameters, it is up to the SIM script writer to ensure that the proper number and type is used.

---

**Note:** It is not possible for a DLL to return a value back to SIM. More specifically, if one is returned, it is ignored. Passing information back to the SIM script should be done using references. Refer to the [Parameter Passing](#).

---

## DLLCallW

The `DLLCallW` command is used for string variables. The value is interpreted as Unicode data when passed back into SIM. This command calls a function contained in the DLL with Unicode. The syntax for this command is:

```
DLLCallW handle, dll_name( [parm1 [parm2 [parm3...]] ] )
```

Where `handle` is the previously loaded library handle, `dll_name` is the name of the function, and `parm#` are the optional parameters.

This command performs the same tasks as `DLLCall`.

Since it is not possible for SIM to check the validity of the parameters, it is up to the SIM script writer to ensure that the proper number and type is used.

## DLLFree

The `DLLFree` command is used to free a loaded DLL. The syntax is:

```
DLLFree handle
```

Where `handle` is the handle obtained in a `DLLLoad` command. This function is automatically called when OPS exits, or the SIM script is reread. It can be called to free up resources loaded by the DLL.

## Parameter Passing

There are three types of variables in SIM:

- integers
- strings
- monetary data

Only these types may be used as parameters to the DLL. However, each type may be passed in by value or by reference, and each type may also be passed in as an array. Therefore, there are 12 possible parameter types. Refer to the table on page 5.

To pass by reference, place the string “ref” before the parameter. For example:

```
// Pass by value
DLLCall handle, my_function( count )
// Pass by reference
DLLCall handle, my_function( ref count )
```

Only variables can be passed in by reference. Complex expressions must be passed in by value.

```
// Will generate an error
DLLCall handle, my_function( ref count + 1 )
DLLCall handle, my_function( ref ( 1 + 3 ) )
```

Parameter, and this allocated data (or a reference to it) will be passed to the DLL. No references to the stored copy of the data will be passed. If by reference, SIM will copy in the new values to the data variables once the function has completed. Therefore, do not pass in huge arrays by reference when not needed, since SIM will attempt to copy in each array element, even if it has not changed.

All pointers passed to the DLL are passed in as 32-bit pointers. All strings are C nul-terminated strings. All integer values are signed. All arrays are passed as a pointer to a list of pointers or integers. The length of the array must either be passed in as an argument, or known prior by the DLL.

Though there are 12 ways of passing in parameters, there are only five separate ways to declare them in C.

**Table 153 C Parameter Declaration**

1	int a	// integer
2	int *a	// integer pointer
3	int a[]	// array of integers
4	char *a -or- wchar_t *a	// string pointer -or- // string pointers (use for Unicode)
5	char *a[] -or- wchar_t *a[]	// array of string pointers -or- // array of string pointers (use for Unicode)

The following table lists the different possibilities and how they map to the parameter type.

**Table 154 SIM Type Mapping to C Declaration**

SIM Type	C Declaration	Comments
integer	int a	-
integer by reference	int *a	-
integer array	int a []	-
integer array by reference	int a []	Same as integer array

SIM Type	C Declaration	Comments
string	char *a	-
string reference	char *a	Same as string
string array	char *a []	-
string array by reference	char *a []	Same as string array
amount	char *a	-
amount by reference	char *a	Same as amount
amount array	char *a	-
amount array by reference	char *a	Same as amount array
integer array	int a []	-

## Integers

### By Value

N1-N9 integers are passed in as 32-bit signed values. N10 and above are passed in as pointers to a string which contains the numeric value expressed as a string.

For example, an N12 numeric variable whose value is 12345 will be passed in as "12345." If the number is negative, then a "-" will be the first character in the string. (The reason for this is that a 32-bit integer can only have nine digits.)

### By Value Examples

```
var a:N9 = 4
var b:N10 = 3012108000
DLLCall handle, my_function( a, 10, (1 + a) * 10, b )
```

The DLL prototype should look as follows:

```
void my_function( int p1, int p2, int p3, char *p4 );
```

The DLL function should expect these parameters:

```
4
10
50
"3012108000"
```

### By Reference

N1-N9 integers are passed in as pointers to a 32-bit value. The DLL can change this value, and this change will be reflected in the variable.

N10 variables are passed in as strings. The length of the string is guaranteed to be the length of the string variable.

An N12 variable with a value of "123" will be passed in as "123," but the space occupied by the string will be at least 13. This means that the DLL can safely copy in a string longer than "123."

---

### By reference examples

```
var a:N9 = 12
var b:N12 = 3012108000
DLLCall handle, my_function( ref a, ref b )
```

The DLL prototype should look like:

```
void my_function( int *p1, char *p2 )
```

The dll function should expect these parameters:

```
pointer to 12
"3012108000"
```

### Strings

All string parameters are passed in as a pointer. When by reference, SIM will copy the string data back into the original variable.

### By Value

The string parameter is passed in as a pointer to a nul-terminated string.

### By Value Examples

```
var a:A20 = "12345"
DLLCall handle, my_function( a, "hello" )
```

The DLL prototype should look like:

```
void my_function( char *p1, char *p2 )
```

The DLL function should expect these parameters:

```
"12345"
"hello"
```

### By Reference

The string parameter is passed in as a pointer to a nul-terminated string. However, the memory reference will be guaranteed to have allocated enough space for the declared string.

For example, if a string is declared as A20 but is set to "12345," then the string passed in will be "12345," but will have 20 characters allocated (not including the nul terminator)

The DLL can then write up to 20 characters into the string.

### By reference example

```
var a:A20
DLLCall handle, my_function( ref a )
```

The DLL prototype should look as follows:

```
void my_function( char *p1 )
```

The DLL should expect these parameters:

```
""
```

The DLL could copy a string of up to 20 characters.

```
memset( p1, '-', 20 )
p1[ 20 ] = 0
```

---

## Monetary Data

All SIM monetary data (\$ variables) are kept as strings internally. Each string consists of the digits which make up the value. There is no representational difference between monetary amounts and numeric data N10 and greater.

The difference between the two is determined by the operations allowed on the values. The operations involved are the assignment and arithmetic ones.

Therefore, monetary amounts are passed to the DLL as numeric strings. However, they will have the decimal point inserted into the proper place.

### By Value

The string parameter is passed in as a pointer to a nul-terminated string. A '-' will be placed at the beginning of the string if it is negative.

### By Value Example

```
var a:$12 = 12.34
DLLCall handle, my_function( a, a + 1.11, 5.67 )
```

The DLL prototype should look as follows:

```
void my_function( char *p1, char *p2, char *p3 )
```

The DLL should expect these parameters:

"12.34"

"13.45"

"5.67"

### By Reference

The string parameter is passed in as a pointer to a 0-padded nul-terminated string. The string will be padded with as many zeroes to make it the same as its declared length. A \$12 variable string will have 12 digits and one decimal point. (The nul is not included.)

### By Reference Example

```
var a:$12 = 12.34
DLLCall handle, my_function( ref a )
```

The DLL prototype should look like:

```
void my_function( char *p1 )
```

The DLL should expect these parameters:

"0000000012.34"

## Array References

All arrays are passed in as an array of pointers or integers. As with SIM subroutine calls, all arrays must have a [] following them.

Note that arrays and arrays by reference use the same declaration. The only difference between the two is that the values are copied back to the variables when the function is done.

N1-N9 numeric values are passed in as integers.

```
var array[ 20 ] : N9
```

```
// Passing in by value.
```

---

```
// DLL prototype should be: void my_function( int array[] );
DLLCall handle, my_function( array[] )

// Passing in by reference.
// DLL prototype should be: void my_function( int *array[] );
DLLCall handle, my_function( ref array[] )
```

All other types are passed in as strings.

```
var array1[ 20 ] : $12
var array2[ 40 ] : A40

// Passing in by value
// DLL prototype should be:
// void my_function( char *array1[], char *array2[] );
DLLCall handle, my_function( array1[], array2[] )

// Passing in by reference
// DLL prototype should be:
// void my_function( char *array1[], char *array2[] );
DLLCall handle, my_function( ref array1[], ref array2[] )
```

## DLL Error Messages

The following is a list of DLL error messages and an example of each.

---



---

**Note:** If the DLL itself has an error in the function, or the wrong values are passed into it, the Ops process of the workstation running the SIM application will fail, and a signal 11 error will display on the server.

To correct this problem, restart the workstation from the System/Control Workstations module within the Enterprise Management Console (EMC).

---



---

### General Error Messages

#### ISL Error on Line ###:## Can Not Evaluate (END OF LINE)

This error occurs when the ISL script has no DLL handle in the call line.

(###:## represents line number:column number)

**Example:** DLLLoad (no handle specified)

#### ISL Error on Line ###:## Expected Operand (END OF LINE)

This error occurs when a file name is missing from the expression.

(###:## represents line number:column number)

**Example:** DLLLoad dll\_handle\_1,

#### ISL Error on Line ###:## File Name Too Long

This error occurs when the file name is too long.

(###:## represents the line number:column number)

**Example:** thisfilenameistoolong.dll

---

### **ISL Error on Line ###:## Not a Variable (“filename. dll”)**

This error occurs when a non-existent DLL is called.

(###:## represents line number:column number)

**Example:** `DLLLoad "filename.dll"` where “filename” is the name of the DLL to be loaded, and it cannot be found

- OR -

This error occurs when the arguments are reversed.

(### represents the line number)

**Incorrect Example:** `DLLLoad "filename.dll", dll_handle_1`

**Correct Example:** `DLLLoad dll_handle_1, "filename.dll"`

Where “filename” is the name of the DLL

### **Maximum Number of DLLs Loaded**

This error occurs when the maximum number of DLLs is loaded. The maximum of 20 DLLs is allowed per SIM interface.

### **DLLCall Error Messages**

#### **ISL Error Expected Operand**

This error occurs when a DLLCall is made without arguments.

**Example:** `DLLCall`

#### **ISL Error Variable Undefined**

This error occurs when a DLLCall is made without a function name.

**Example:** `DLLCall dll_handle_1`

- OR -

This error occurs when a DLLCall is made with a non-existent function.

#### **ISL Error Undefined Function**

This error occurs when a DLLCall is made without a handle name.

**Example:** `DLLCall my_function(3)`

-OR-

This error occurs when a DLLCall is made with the arguments reversed.

**Example:** `DLLCall my_function(3), dll_handle_1`

### **DLLFree Error Messages**

#### **ISL eError Expected Operand**

This error occurs when a DLLFree is made without arguments.

**Example:** `DLLFree`

#### **ISL Error Variable Undefined**

This error occurs when a DLLFree is made with an incorrect handle name.

**Example:** `DLLFree wrong_handle_name`

---

---

# Appendix E SIM Events

This chapter provides a brief overview of SIM events and their use.

## Overview

SIM events can be categorized as:

- Directly triggered by a keystroke (for example, INQ and TMED)
- Indirectly triggered by an event in Ops (for example, SIGN\_IN and FINAL\_TENDER)
- Triggered by a SIM script (for example, TIMER and RXMSG)

### Events Directly Triggered by a Keystroke

The following are characteristics of these types of events:

- The event must be defined in the script. If a **SIM Inquire** key is pressed, then the corresponding “event inq:#” code must be in the SIM script. If the event is not in the SIM script, an error is generated.
- The event is specific to a PMS interface, and therefore, only one SIM event is executed.

### Events Indirectly Triggered by an Ops Event

The following are characteristics of these types of events:

- The event doesn’t have to be defined in the script. For example, if the SIM script has the FINAL\_TENDER event programmed, then it will be executed whenever a check is completely tendered. If the event is not defined, then no error will occur.
- These events occur for *all* interfaces. When a check is completely tendered, then there will be an attempt to run the FINAL\_TENDER in all SIM scripts. Each script has the chance to “hook in” to the event.
- Scripts are executed in the order that the PMS interface definitions appear in the Remote Management Console, in *RVC Information | RVC Parameters | Interfaces*. If the script file does *not* have the event, it is ignored— the events cannot be cancelled. That is running the *ExitCancel* command inside the script will not stop the operation from occurring.
- Some events have two variations—a *regular* event and a *confirm* event. The confirm event can optionally prevent the action from continuing, whereas the regular SIM cannot. Refer to [SIM Confirm Events](#) for details on confirm events.

### Event-Specific Variables

Many of the events have system variables (for example, @ variables) that are specific to that event only.

## Quick Reference Table

The table below lists the events available in SIM, and the variables, if any, that can be used. Each column is described as follows:

- **T:** Identifies the type of event:
- **K:** keystroke event
- **O:** Ops event
- **S:** SIM-triggered event
- **C :** Indicates the event can be a confirm event and the operation can be cancelled by the script (**Y**es/**N**o)
- **Event:-** Identifies the name of the event in the SIM script
- **Description:** Describes what the event does
- **Variables:** Lists the specific variables (if any) that can be used with the event type

**Table 155 SIM Events and Corresponding Variables**

T	C	Event	Description	Variables
		ADD_CHECK	Check has been added to the current check	-
O	Y	ADJUST_CHECK	Adjust closed check operation	-
		AUTO_DSC	Auto discounts have been applied	
O	Y	BARCODE	A barcode has been scanned on a barcode scanning device	
O	Y	BEGIN_CHECK	Check has been begun	-
		CA_AUTH	Credit auth has occurred	
		CHANGE_DUE	Check has change due	
O	Y	CLOCK_IN	Employee is clocking in	-
O	Y	CLOCK_OUT	Employee is clocking out	-
O	Y	CLOSE_CHECK	Check has been closed (paid in full); functionality is equivalent to the FINAL_TENDER event	-
		CSH_DRWR_ASSIGN	Cash drawer has been assigned	

T	C	Event	Description	Variables
S	Y	CSH_DRWR_CLS	Ops has just required the operator to close the cash drawer on the workstation	-
S	Y	CSH_DRWR_OPN	Ops is opening the cash drawer on the workstation (this event is NOT fired if the cash drawer is somehow opened on the workstation)	-
		CSH_DRWR_UNASSIGN	Cash drawer has been unassigned	
O	Y	DSC	Discount has been entered	@obj - object number of item @qty - quantity of item
		DSC_ENGINE_END	Discount engine has completed	
		DSC_ENGINE_START	Discount engine is ready to run	
		DSC_OVERRIDE	Not implemented	
O	Y	DSC_VOID	Discount has been voided	@obj - object number of item @qty - quantity of item
		END_EVENT	Unused	
O	N	ERR_MSG	Error message has occurred	@errormessage - error
O	N	EXIT	Ops has exited	-
		EXT	Extensibility has been added to the check	
O	N	FINAL_TENDER	Check has been paid in full	-
O	N	INIT	Ops has started	-
K	N	INQ	Inquire event triggered by an Inquire key	-
O	N	LDS_BPS_OFF	LDS bypass has been deactivated at the workstation (for North American LDS only)	-

<b>T</b>	<b>C</b>	<b>Event</b>	<b>Description</b>	<b>Variables</b>
O	N	LDS_BPS_ON	LDS bypass has been activated at the workstation (for North American LDS only)	-
O	Y	MGR_PROC	Employee is running a Manager Procedure	@mngprprocnum - manager procedure number
O	Y	MI	Menu item has been ordered	@obj - object number of item @qty - quantity of item
O	Y	MI_RETURN	Menu item has been returned	@obj - object number of item @qty - quantity of item
O	Y	MI_VOID	Menu item has been voided	@obj - object number of item @qty - quantity of item
O	Y	NO_SALE	No Sale key has been pressed	-
		ORDER_TYPE	Order type changed	
O	Y	PICKUP_CHECK	Check has been picked up	-
O	Y	PICKUP_LOAN	Triggered when a Pickup or Loan is performed	-
		PRINT_HEADER	Printer header event	
		PRINT_TRAILER	Printer trailer event	
		READY	The POS has been initialized and is ready	
		REFERENCE_ENTRY	Cash Management deposit reference entry added	
O	Y	REOPEN_CHECK	Check has been reopened	-
O	Y	RPT_GEN	Employee is running a report	@autoseq
S	N	RXMSG	Message has been received from the PMS system	-
		SELECT_EVENT	An Event has been selected	

T	C	Event	Description	Variables
		SHIFT_INCREMENT	A shift has been incremented	
O	Y	SIGN_IN	Employee is signing in	-
O	Y	SIGN_OUT	Employee is signing out	-
O	Y	SRVC_TOTAL	Transaction has been service totalled	-
		START_EVENT	An event has been started	
O	Y	SVC	Service charge has been entered	@obj - object number of item @qty - quantity of item
O	Y	SVC_VOID	SERVICE charge has been voided	@obj - object number of item @qty - quantity of item
O	Y	SYS_AUTH	Authorization is required	@authemp - authorizing employee
		TAX_DUE	Tax is due event	
S	N	TIMER	An event programmed by a SIM script to fire periodically	-
K	N	TMED	Tender media event triggered by a tender media key	-
O	Y	TNDR	Tender has been entered	@obj - object number of item @qty - quantity of item
O	Y	TNDR_VOID	Tender has been voided	@obj - object number of item @qty - quantity of item
		TOTAL_DUE	Total is due event	
O	Y	TRANS_CNCL	Transaction has been cancelled	-

T	C	Event	Description	Variables
O	Y	VOID_CHECK	Check has been voided	-
		WS_DOWN	Workstation is shutting down	
O	N	WS_EXIT	Workstation is no longer active (for example, a workstation may have exited to DOS)	-
O	N	WS_RESTART	Workstation has been restarted, either due to a workstation reboot or a NetCC restart	-
		WS_UP	Workstation is ready	
		XFER_CHECK	Check has been transferred	

## SIM Confirm Events

The purpose of SIM confirm events is to allow script writers to stop certain POS operations. For example, if a third-party inventory control system is used to count menu items, then the SIM script could query the system when a menu item is ordered, and “cancel” the operation if the item is out of stock.

All confirm events will be run *before* the operation takes place, and the normal event will run after the operation takes place. Therefore, there could be two events in the script: one *confirm* and one *normal*.

Consider the following script:

```
event mi : confirm
    waitforconfirm "Press enter to order item"
endevent

event mi
    waitforclear "You have entered menu item " , @obj
endevent
```

When a menu item key is first pressed, the confirm event will be run first. If the user presses the **Clear** key, the ordering of the menu item will be cancelled. If **Enter** is pressed, the item will be ordered, and the normal event will be run afterwards.

---

**Note:** One important point about confirm events is that, like the normal events, each SIM script will have a chance at running it. That means that each SIM script will be able to cancel the operation. It should not be assumed that allowing an operation in a confirm event will result in the operation taking place.

In addition, a particular item cannot be specified. The events occur for all items (menu items, discounts, tenders, etc.).

---

---

---

## Appendix F Stack Trace

While this is not part of the programming language SIM error messages are now more comprehensible. They offer:

- The line/character where the error was encountered (not always precise due to the usual parsing ambiguities)
- A stack trace indicating the subroutine nesting.

Consider this SIM script. It will fail in “Sub3”.

```
event inq:2
    call Sub1()
endevent

sub Sub1()
    call Sub2()
endsub

sub Sub2()
    call Sub3()
endsub

sub Sub3()
    pancakes
endsub
```

When “inq:2” is run an exception window with two tabs will be raised:

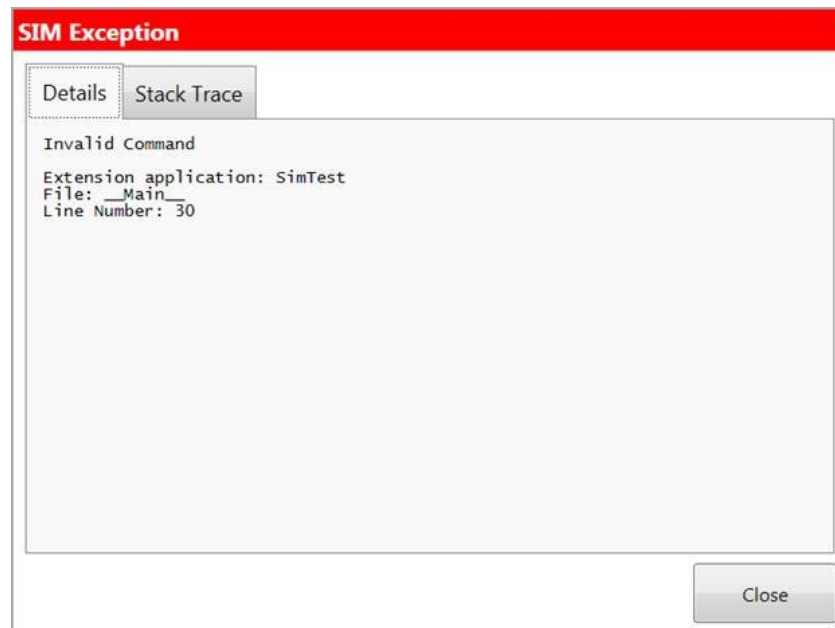

Figure 11 SIM Exception



---

---

## Appendix G SIM.net

Perhaps the greatest leap forward in the SIM 2.x infrastructure is support for .net objects. This feature is collectively known as “SIM.net”.

If one wanted to access separately compiled code in other products the only options were:

- Create a C DLL
- Run the ‘system’ command

While both work, they can be awkward. The characteristics of SIM.net are:

- A new data type: “object”. It is peer level with N, A, and \$. For example: var sb:object
- Object data types are always .net objects.
- The .net objects can be either .net framework objects such as StringBuilder or custom objects
- Object data types are weakly typed. There is no compilation phase on a SIM script. When a method, field, or property is accessed SIM uses reflection at the moment of expression evaluation to determine if the reference is valid.
- Since objects are weakly typed, they can be assigned different types during their lifetime. For example, an object ‘X’ can be a StringBuilder on one line and an Int32 on the next.
- Static references are supported.
- The syntax for creating and referencing objects has been kept as close to the C# syntax as possible.

Limitations (current):

- One cannot create new class definitions as one can in C#.
- Nested class references not supported. That is, one cannot access in SIM a class nested in another class.
- Generic instantiations do not support. Use non-generic equivalents. For example, List<string> is not available. Use ArrayList.
- User-written DLLs are not supported on iPad
- .net arrays cannot be created even though they can be accessed. To create one use ArrayList.
- The .net framework on Windows CE is more limited than the full framework on Win32. Use MSDN to verify which properties/fields/methods are available for your objects.
- No support for *foreach*. Use iterators (sample below).
- No support for delegates.

*Construction*

- Objects are constructed using the ‘new’ keyword in the same way as C#.

- 
- Overloading of constructors is supported. SIM will try to match the most appropriate constructor. Note the word 'try'. If there are multiple constructors, then SIM will first match on parameter count. After that SIM will try to find the first matching constructor. Unfortunately, SIM can 'guess' wrong and the method rejects the attempt. The solution is to try a different constructor. If you encounter a constructor that makes it impossible to create an object, please post on the Sharepoint site so that we can look into it.

Examples:

```
var sb:object

// overloaded
sb = new System.Text.StringBuilder()
sb = new System.Text.StringBuilder( "this is a string" )
```

*Usage*

It would be difficult to explain all usages, so the following script shows the power of SIM.net and also how to access the various .net types. The following simple script shows how one could leverage .net in a SIM script.

```
// static calls, both stand-alone and in assignment
System.String.Equals( "a", "a" )
var result:N = System.String.Equals( "a", "a" )

// Create instance of object.
var sb:object = new System.Text.StringBuilder()

// Function calls with chaining.
sb = sb.Append( "hello" ).Append( " " ).Append( "world" )

// conversion of string to SIM text
var text:a = sb.ToString()

// SIM arrays and object storage.
var sbArray[10] : object
sbArray[5] = new System.Text.StringBuilder()
sbArray[5].Append( "hello" )
text = sbArray[5].ToString().ToUpper()

// Params support
text = System.String.Format( "hello world" )
text = System.String.Format( "hello world {0}", 0, 1, 2 )
text = System.String.Format( "hello world {0} {1}", 0, 1 )
text = System.String.Format( "hello world {0} {1} {2}", 0, 1, 2 )
text = System.String.Format( "hello world {0} {1} {2} {3}", 0,
System.Convert.ToDateTime( "11/22/2003" ), 2, 3 )
```

---

## Access to C# extensibility events

The C# extensibility provides a very rich set of events that until recently was not available to SIM. Starting with version 2.6 (build 0.99) SIM has complete access to all extensibility events and their arguments. The C# extensibility events are much more detailed and there are many more of them.

It is easiest to explain with an example script dealing with the sign-in event.

### *The old way*

The legacy way to hook into the sign in event was the “sign\_in” keyword:

```
event sign_in
    @OpsContext.ShowMessage( "inside sign_in " )
endevent
```

### *The new way*

```
event init
    SubscribeToEvent "OpsSignInEvent", "SignInEvent"
endevent

event SignInEvent( var sender:object, var args:object )
    @OpsContext.ShowMessage( "inside SignInEvent" )
endevent
```

The new commands are:

```
SubscribeToEvent eventName, scriptEventName
UnsubscribeFromEvent eventName, scriptEventName
UnsubscribeFromAllEvents
```

Where:

1. *eventName* is the standard OpsEventType. For example, “OpsSignInEvent”.
2. *scriptEventName* is the script event identifier.

The ‘event’ command now has a new syntax for these new event types. It is compatible with the old syntax. The new event syntax is:

```
event scriptEventName( var senderVariableName : object,
    argsVariableName : object )
```

Notes:

- The only parts of the event syntax that you can change are *scriptEventName*, *senderVariableName*, *argsVariableName*. The rest of the line must remain exactly as is. For example, the following lines will *not* work:
  - event OpsSignInEvent( ref sender, ref args )
  - event OpsSignInEvent( sender, args )
- You may name the ‘sender’ and ‘args’ variables anything you like but

---

you may want to keep them as 'sender' and 'args' to keep them consistent with the .net framework eventing style.

- You do not have to cast the args to the type appropriate for the event. SIM uses late binding for all object types and therefore you can access any field directly from args.
- The *sender* and *args* variables are the same as what is passed into a C# extensibility EventMonitorDelegate delegate.
- When subscribing to events consult the extensibility documentation for a list of all event types and event arguments.
- When a script is 'destroyed' (for example, when a change is made to the script in EMC while OPS is running) all events will automatically be unsubscribed.
- ExitContinue will allow any preview event to continue, ExitCancel will abort the event. ExitCancel has no meaning on non-preview events.

#### *Multiple Subscriptions*

A script can subscribe to the same event (for example, "OpsSignInEvent") with multiple SIM event handlers. For example:

```
event init
    SubscribeToEvent "OpsSignInPreviewEvent",
    "SignInPreviewEvent"
    SubscribeToEvent "OpsSignInPreviewEvent",
    "SignInPreviewEvent2"
endevent

event SignInPreviewEvent( var sender:object, var args:object )
    var text:A = System.String.Format( "Sign in preview event:
employee {0}", args.EmployeeID.Value )
    @OpsContext.ShowMessage( text )
endevent

event SignInPreviewEvent2( var sender:object, var args:object )
    var text:A = System.String.Format( "Sign in preview event
2: employee {0}", args.EmployeeID.Value )
    @OpsContext.ShowMessage( text )
    ExitCancel
endevent
```

In the example above both SignInPreviewEvent and SignInPreviewEvent2 will be called when the operator attempts to sign in.

It is also possible to subscribe to the same event with the same script event name though it is unclear why one would do this. However, if you find that your script event is being called more than once per event this is most likely the reason.

```
event init
    // subscribe to the same event with the same event handler
    SubscribeToEvent "OpsSignInPreviewEvent",
    "SignInPreviewEvent"
    SubscribeToEvent "OpsSignInPreviewEvent",
    "SignInPreviewEvent"
endevent

// this will be called twice
event SignInPreviewEvent( var sender:object, var args:object )
```

---

```

        var text:A = System.String.Format( "Sign in preview event:
employee {0}", args.EmployeeID.Value )
        @OpsContext.ShowMessage( text )
    endevent

```

*Accessing args properties*

This example shows how to access the EmployeeID field on args in the preview event.

```

event SignInEvent( var sender:object, var args:object )
    var text:A = System.String.Format( "Sign in preview event:
employee {0}", args.EmployeeID.Value )
    @OpsContext.ShowMessage( text )
endevent

```

This example shows how to access the object number field in the menu item master in the OpsMiEvent.

```

event init
    SubscribeToEvent "OpsMiEvent", "MiEvent"
endevent

event MiEvent( var sender:object, var args:object )
    var text:A = System.String.Format( "Mi event event: master
object number {0}", args.MiMaster.ObjectNumber )
    @OpsContext.ShowMessage( text )
endevent

```

## Exception handling

In previous SIM implementations it was not possible to ‘catch’ errors in a script. SIM has implemented a try/catch mechanism with the following characteristics:

- All SIM exceptions are .net objects. Therefore, any exceptions thrown by SIM and regular .net framework objects are equivalent.
- Try/catches can be nested.
- One can only catch a single exception. In .net one can have multiple catch statements per ‘try’, in SIM there is only one catch statement
- There is no ‘finally’.
- One can throw an exception in SIM as a way of unwinding the stack in a more graceful way.

Example:

```

event inq:1
    try
        call TestTryCatch2()
    catch ex
        // many options; Log to disk, raise error window, ...
        Outputdebugstring ex.Message
        Outputdebugstring ex.Details
        Outputdebugstring ex.SimStackTrace
    endtry

```

---

```

endevent

sub TestTryCatch2()
    call TestTryCatch3()
endsub

sub TestTryCatch3()
    throw new System.Exception( "exception inside sim" )
endsub

```

### PrintSimFeatures

The PrintSimFeatures command is used to print out all commands, system variables, and functions for the current build. The syntax is:

```
PrintSimFeatures printer_object_number
```

### @OpsContext and @DataStore

These two objects are discussed in the extensibility documentation. SIM provides access to them via these two system variables. Since they are both .net objects one can access them in the same way that one would access .net framework objects.

```

event inq:1
    @OpsContext.ShowMessage( System.String.Format( "The current
seat is {0}", @OpsContext.ActiveSeat ) )
endevent

event inq:2
    var dbObject :object

    // menu item master
    dbObject = @DataStore.ReadMenuItemMasterByNum( 1 )
    call ShowObjectName( dbObject )

    // discount
    dbObject = @DataStore.ReadDiscountByNum( 1 )
    call ShowObjectName( dbObject )

    // read all discounts and enumerate over all until
condition is met
    var dbObjectList:object = @DataStore.ReadAllDiscounts()
    var dbEnumerator:object = dbObjectList.GetEnumerator()
    while dbEnumerator.MoveNext()
        dbObject = dbEnumerator.Current
        if dbObject.ObjectNumber = 2
            call ShowObjectName( dbObject )
            break
        endif
    endwhile
endevent

sub ShowObjectName( ref dbObject )

```

---

```

        if dbObject = @null
            @OpsContext.ShowError( "Object not found" )
        else
            var typeName:A = dbObject.GetType().Name
            var recordName:A = dbObject.Name.ToString()
            var msg:A = System.String.Format( "Name of record
type {0} is {1}", typeName, recordName)
            @OpsContext.ShowMessage( msg )
        endif
    endsub

```

### Using custom DLLs

One can access objects a user-compiled DLL on win32 and CE. (This functionality is not yet available on iPad). Before one can use an external DLL the 'NetImport' command must be provided. The purpose of this command is like a .net project reference. There are two forms: one for release and one for testing:

```

NetImport from "MyLibrary.dll"
NetImport from &"Path/MyLibrary"

```

The first statement is used in a production environment when OPS writes the DLLs to disk from the database. The second form is used to load the DLL from a disk file. (Note the &) This can make troubleshooting DLLs much easier as they do not have to go into the database first. And example of the second one is:

```

NetImport from &"D:\MyProject\bin\Debug\SimTestLibrary.dll"

```

One can also put namespaces in the NetImport command immediately after the NetImport word. The namespaces are separated by a comma and are equivalent to the 'using' statement in C#.

```

NetImport SimTestLibrary.Classes, \
        SimTestLibrary.Definitions \
        from "SimTestLibrary.dll"

```

NetImport statements must be at the top of a SIM script and cannot be run inside an event or sub. Once the assembly has been imported it can be referenced by SIM. The following is a sample c# class called "TestClass".

```

using System.Collections.Generic;
using System.Reflection;
using System.Text;

namespace SimTestLibrary.Classes
{
    public enum Colors
    {
        Blue = 20,
        Red,
        Green,
    }

    public class TestClass
    {
        public enum Colors
        {

```

---

```

        Blue = 20,
        Red,
        Green,
    }

    // Constructors.
    public TestClass()
    {
    }

    public TestClass( int number )
    {
    }

    public TestClass( long number, string text )
    {
    }

    // Properties
    public int IntProperty
    {
        get { return m_IntProperty; }
        set { m_IntProperty = value; }
    }

    public string StringProperty
    {
        get { return "this is a string"; }
    }

    public decimal CalculatedDecimal( decimal total ) { return total *
3; }

    // Indexers
    public string this[ string s ]
    {
        get { return s.ToUpper(); }
    }

    public string this[ int i ]
    {
        get { return i.ToString(); }
    }

    public string GetString()
    {
        return "fred";
    }

    public string GetString( string text)
    {
        return "fred " + text;
    }

    public string GetString( string text1, string text2 )
    {
        return "fred " + text1 + " " + text2;
    }

    public int GetInt( int i )
    {
        return i * 2;
    }

    public string Concatenate( params object[] strings )
    {
        var sb = new StringBuilder();
        foreach ( string s in strings )
            sb.Append( s );
        return sb.ToString();
    }

    public void RefFunction( ref string text )
    {
        text = "hello";
    }

    public int[] ArrayField = new int[] { 1, 2, 3 };
    public int IntField = 5;

```

```

        public bool BoolField = true;
        static public StringBuilder SB = new StringBuilder( "a string
builder" );
        public string MyText = "1, 2, 3";
        static public string StaticText = "hello";
        static public Dictionary< int, string > StaticDictionary = new
Dictionary<int,string>() { { 1, "number 1"}, { 2, "number 2" } };
        static public Assembly GetCallingAssembly()
        {
            return Assembly.GetCallingAssembly();
        }
        private int m_IntProperty = 0;
    }
}

```

The following SIM script accesses members on this class:

```

event inq:1

// Overloaded constructors
var obj:object = new TestClass()
obj = new TestClass( 1 )
obj = new TestClass( 1, "asildjlasdjklaj" )

// Properties
obj.IntProperty = 12312
var i:n = obj.IntProperty * 2
var text:A = obj.StringProperty

// Overloaded indexers on an object
text = obj[ 123 ]
text = obj[ "123" ]

// Functions on object.
text = obj.GetString().ToUpper()
text = obj.GetString( "aaa" ).ToUpper()
text = obj.GetString( "aaa", "bbb" ).ToUpper()

// Array access.
i = obj.ArrayField[ 2 ]

// Field access.
obj.IntField = 123
i = obj.IntField

// Object access on object.
text = TestClass.SB.ToString()
text = obj.MyText
text = TestClass.StaticText

// Function call.
text = obj.Concatenate( "a", "b", "c" )

// Enums.
var num:n
num = SimTestLibrary.Classes.Colors.Blue

```

---

```
num = SimTestLibrary.Classes.TestClass.Colors.Blue
num = SimTestLibrary.Classes.TestClass.Colors.Green

// Generics access.
var dictionary : object = TestClass.StaticDictionary
text = dictionary[ 1 ]
OutputDebugString TestClass.StaticDictionary.ContainsKey( 2 )

endevent
```

---

---

# Appendix H Glossary

## Argument

An **argument** is a generic term for an item or group of items that is used in the syntax of a command that refers to the information that is required by the command. It may be an alphanumeric character, group of characters, or word(s) that receive the action of a command or function. For example, the **Call** command requires an argument (such as the variable name) to work.

See also: Array, Constant, Equation, Expression, Function, Input Expression, Prompt Expression, String Expression, Syntax, System Variable, and User Variable.

## Array

An **array** is a set of values, based on the name of a User Variable. A User Variable Array (or Array Variable) identifies each value by the variable name and the index number, in brackets. For example, an Array called Rooms that has 20 values would be identified from Rooms [1] to Rooms [20].

See also: User Variable

## Asynchronous Serial Interface

An **asynchronous serial interface** is a full duplex interface supporting transmission speeds of 300 to 9600 baud.

## Concatenate

**Concatenate** means to join two or more text strings together to form a single contiguous string.

## Constant

A **constant** is a value that does not change (the opposite of a variable). For example, the Window command can use a constant (such as window 5, 36).

See also: Expression and Variable

## Equation

An **equation** is a mathematical formula. The ISL may use the following operators within a formula: addition (+), subtraction (-), division (/), multiplications (\*), greater than (>), or less than (<). Parentheses may be used to isolate parts of the equation, as necessary.

See also: Expression, Formula, and Operator

## Expression

An **expression** is a place holder argument that can be one of the following:

- User Variable
- System Variable

- 
- Constant
  - String
  - Function
  - Equation

See also: Argument, Hex Expression, Input Expression, Numeric Expression, and String Expression

## Format Specifiers

See [Operators](#).

## Formula

A **formula** can be used to calculate numeric values, compare one value to another, and select an action based on a comparison, and join multiple string expressions into a single string. The ISL may use the following operators within a formula: addition (+), subtraction (-), division (/), multiplications (\*), greater than (>), or less than (<). Parentheses may be used to isolate parts of the equation, as necessary.

See also: Equation and Operator

## Function

A **function** is a built-in ISL procedure used to evaluate fields, make calculations, or convert data.

See also: Expression

## Global Command

A **global command** is a command that is allowed outside of an event procedure. They are initialized at the beginning of each script and then maintained for the duration of that script. The following ISL commands are global:

- ContinueOnCancel
- DiscardGlobalVar
- ExitOnCancel
- Prorate
- RetainGlobalVar
- SetSignOnLeft
- SetSignOnRight
- UseBackUpTender
- UseCompatFormat
- UseISLFormat
- UseISLTimeOuts
- UseSTDTimeOuts Var

See also: Local Command

---

## Global Variable

A **global variable** is declared outside an event procedure, and usually initialized at the beginning of each script. The value of each global variable is maintained throughout all Events unless the script is changed or the **DiscardGlobalVar** command is used.

See also: Local Command

## Hex Expression

A **hex expression** is a variable or function whose value must be a hexadecimal number. This variable is used with the **GetHex** and **Bit** functions.

See also: Expression

## Input Expression

An **input expression** is an Array or User Variable that requires user input. The input expression is used by the **DisplayInput**, **DisplayMS**, **Input**, and **InputKey** commands.

See also: Array, Expression, and User Variable

## Integer

An **integer** is a positive or negative whole number or a zero, always without decimal places.

## Interface Script Language (ISL)

The **Interface Script Language (ISL)** provides the facility to direct operator prompting, message formats, printing, and subsequent POS processing. A script is analyzed and executed by the System Interface Module (SIM).

See also: ISL Script

## ISL

See [Interface Script Language](#).

## Language Element

**Language Elements** are indivisible pieces of information which, if broken apart with whitespace, will generate an ISL error. The following items are considered language elements:

- Command Names
- Function Names
- System Variables
- Relational and Boolean Operators
- Input and Output Specifiers
- Comment Symbols (//)
- Continuation Line Symbol (\)

- 
- Commas
  - Any Word and/or Symbol required by the Syntax

## Local Command

Most ISL commands are considered **local commands**, in that they must be placed inside an Event procedure and only affect the processing within that event.

See also: Global Command

## Local Variable

A **local variable** must always be declared inside an event procedure and will only be used by the event and any subroutines called by that event. Local variables are purged after each event is complete, (when an **EndEvent** is executed).

See also: Global Variable

## Nesting

Nesting is the act of using an **If**, **For**, **Forever**, or **While** command inside another. Since each of these commands is executed until its corresponding **EndIf**, **EndFor**, or **EndWhile** command is found, the entire **If...EndIf**, **For...EndFor**, **Forever...EndFor**, or **While...EndWhile** nest must exist before the outer **End...** command. Nesting also refers to the ability to call a subroutine from within another subroutine.

## Null String

A **null string** (" ") is a string expression that contains no characters. All string variables are initially set to null at the beginning of each Event procedure.

See also: Expression and Variable

## Number of Records

**Number of Records** is used to send and receive variable amounts of data via a list or a list array.

## Numeric Expression

A **numeric expression** is a variable or function whose value must be a number. A number expression is used when specifying a touchscreen number within the Symphony database.

See also: Expression

## Offset

An **offset** is a decimal integer that is used to calculate a position of a field within a string. For example, this may be used to extract certain field information from a credit card.

---

## Operator

An **operator** is a mathematical symbol that determines what action is taken on variables or constants in the equation. For a complete list of operators, see [Relational and Logical Operators](#).

See also: Expression and String Expression

## Script

A **Script** contains a series of commands, functions, and arguments that perform a particular task at the workstation and/or the PMS.

## SIM

See System Interface Module.

## String

A **string** is a series of connected characters (letters, numbers, symbols, spaces) stored and used as text. In ISL, a string is always in quotes.

See also: Subroutine and User Variable

## String Expression

A **string expression** is a variable or function whose value must be a string. See also: Expression

## Subexpression

A **subexpression** is an expression within an expression. Subexpressions are used with binary operators. For example, in the following expression:  $a + (b + c) + d$ ,  $(b + c)$  is a subexpression.

See also: Expression and Operators

## Subroutine

A **subroutine** allows common code to be used by multiple events. Each subroutine has a unique name which is used to define it within the script, outside any event procedure. Use the **Call** command to execute a subroutine.

## Syntax

A command or function **syntax** is used to show the proper usage and rules that are required to execute it correctly within a script.

## System Interface Module

The **System Interface Module (SIM)** is the component of Symphony that allows the System to interface to a variety of other systems, or third-party systems. A special script language known as the ISL provides access to the SIM.

---

## System Variable

A **system variable** is a predefined name that identifies a value which contains information from the Symphony database.

See also: Argument and Expression

## Token

A **token** can be any individual language element inside a script. See also: Language Element and Token Error.

## Token Error

A **token error** can occur any time an individual language element is used incorrectly. For example, incorrect use of whitewashes, missing commas, or erroneous data at the end of a command statement, and so on. Please see Appendix A for a complete list of error messages.

See also: Language Element and Token

## TTY

See [Asynchronous Serial Interface](#).

## User Variable

A **user variable** is a user-defined name which is assigned a value within a script. The value will remain the same until a newer value is assigned; if no newer value is assigned, the original value is maintained.

See also: Argument and Expression

## Variable

A **variable** is a container whose value changes (the opposite of a constant). See also: Constant