

# Oracle® Retail Xstore Office 21.0

## User Guide



Release 21.0

F56847-01

February 2022

The Oracle logo, consisting of a solid red square with the word "ORACLE" in white, uppercase, sans-serif font centered within it.

ORACLE®

Oracle Retail Xstore Office 21.0 User Guide, Release 21.0

F56847-01

Copyright © 2022, Oracle and/or its affiliates.

Primary Author: Gerlinde Rust

Contributing Authors:

Contributors:

This software and related documentation are provided under a license agreement containing restrictions on use and disclosure and are protected by intellectual property laws. Except as expressly permitted in your license agreement or allowed by law, you may not use, copy, reproduce, translate, broadcast, modify, license, transmit, distribute, exhibit, perform, publish, or display any part, in any form, or by any means. Reverse engineering, disassembly, or decompilation of this software, unless required by law for interoperability, is prohibited.

The information contained herein is subject to change without notice and is not warranted to be error-free. If you find any errors, please report them to us in writing.

If this is software or related documentation that is delivered to the U.S. Government or anyone licensing it on behalf of the U.S. Government, then the following notice is applicable:

U.S. GOVERNMENT END USERS: Oracle programs (including any operating system, integrated software, any programs embedded, installed or activated on delivered hardware, and modifications of such programs) and Oracle computer documentation or other Oracle data delivered to or accessed by U.S. Government end users are "commercial computer software" or "commercial computer software documentation" pursuant to the applicable Federal Acquisition Regulation and agency-specific supplemental regulations. As such, the use, reproduction, duplication, release, display, disclosure, modification, preparation of derivative works, and/or adaptation of i) Oracle programs (including any operating system, integrated software, any programs embedded, installed or activated on delivered hardware, and modifications of such programs), ii) Oracle computer documentation and/or iii) other Oracle data, is subject to the rights and limitations specified in the license contained in the applicable contract. The terms governing the U.S. Government's use of Oracle cloud services are defined by the applicable contract for such services. No other rights are granted to the U.S. Government.

This software or hardware is developed for general use in a variety of information management applications. It is not developed or intended for use in any inherently dangerous applications, including applications that may create a risk of personal injury. If you use this software or hardware in dangerous applications, then you shall be responsible to take all appropriate fail-safe, backup, redundancy, and other measures to ensure its safe use. Oracle Corporation and its affiliates disclaim any liability for any damages caused by use of this software or hardware in dangerous applications.

Oracle, Java, and MySQL are registered trademarks of Oracle and/or its affiliates. Other names may be trademarks of their respective owners.

Intel and Intel Inside are trademarks or registered trademarks of Intel Corporation. All SPARC trademarks are used under license and are trademarks or registered trademarks of SPARC International, Inc. AMD, Epyc, and the AMD logo are trademarks or registered trademarks of Advanced Micro Devices. UNIX is a registered trademark of The Open Group.

This software or hardware and documentation may provide access to or information about content, products, and services from third parties. Oracle Corporation and its affiliates are not responsible for and expressly disclaim all warranties of any kind with respect to third-party content, products, and services unless otherwise set forth in an applicable agreement between you and Oracle. Oracle Corporation and its affiliates will not be responsible for any loss, costs, or damages incurred due to your access to or use of third-party content, products, or services, except as set forth in an applicable agreement between you and Oracle.

# Contents

## Send Us Your Comments

---

### Preface

---

Audience	xvi
Documentation Accessibility	xvi
Related Documents	xvi
Customer Support	xvi
Review Patch Documentation	xvii
Improved Process for Oracle Retail Documentation Corrections	xvii
Oracle Retail Documentation on the Oracle Help Center (docs.oracle.com)	xvii
Conventions	xvii

## 1 Getting Started

---

Prerequisites	1-1
Browser Requirement	1-1
Accessing Oracle Retail Xstore Office	1-2
Changing Your Password	1-6
Requesting a Forgotten Password	1-6
About this Guide	1-6

## 2 Roles, Users, and Security Access

---

Oracle Retail Xstore Office Areas Controlled by Security	2-1
About this Chapter	2-1
User Roles	2-2
Creating/Editing User Roles	2-2
About Privileges	2-4
Administration	2-5
Configurator	2-5
Customization	2-6
DataManager	2-6

DeploymentManager	2-7
Home Page	2-8
Reports	2-8
Support	2-9
Admin Users - Using Roles to Grant Access to Oracle Retail Xstore Office	2-10
Creating New Oracle Retail Xstore Office User Accounts	2-10
Editing Oracle Retail Xstore Office User Accounts	2-12
Password Options - Non LDAP	2-14
Passwords: Special Characters & Rules	2-15
Password & User ID Configuration	2-16
Additional Password Requirements	2-16
Resetting a User's Password	2-17
LDAP Authentication	2-17
Assumptions and Requirements for LDAP Users	2-18
Additional Details for LDAP Authentication	2-18
Oracle Retail Xstore Office LDAP Settings	2-18

## 3 System Management

---

About this Chapter	3-1
Where To Look For User Settings Information	3-1
Oracle Retail Xstore Office Configuration	3-1
Oracle Retail Xstore Office Configuration Options	3-2
Country Pack - Brazil	3-2
Deployment Category	3-2
General Category	3-3
Omni Channel Data Service	3-5
Purge	3-5
Temporary Store Server Management	3-8
Reports Category	3-8
User Account Category	3-8
Customization Management	3-10
Uploading Configuration Files	3-10
Exporting Active Configuration Files from the Configuration List	3-11
Deleting Configuration Files from the Configuration List	3-11
Job Management	3-12
Organization Management	3-13
Adding an Organization	3-13
Editing an Organization	3-14
System Manager	3-14
Credentials Storage	3-15

Store Authorization Manager	3-15
Store Enrollment	3-16
Available Locales	3-18
Where Locale Is Used	3-19

## 4 Profile Management

---

About this Chapter	4-1
Setup Overview	4-2
Summary	4-2
Profile Maintenance	4-2
Setting Up Profile Groups & Elements	4-2
Profile Group and Element Versioning	4-5
About Profile Group and Element Versioning	4-5
Personality Maintenance	4-6
Personality Setup Options	4-7
General Information	4-7
Base Features	4-7
Overrides	4-8
Review	4-8
Landscape Maintenance	4-8
Adding a New Landscape	4-9
Editing an Existing Landscape	4-11
Store Personality Maintenance	4-11

## 5 Configurator

---

About this Chapter	5-1
Configuration Options and Availability Matrix	5-1
Configuration Versioning	5-2
Managing Configurations	5-3
Configuring Codes	5-5
Code Configuration Options	5-7
Configuring Discounts	5-8
Discount Configuration Options	5-10
Basic Information	5-10
Calculation Information	5-10
Customize Configuration Options	5-11
Discount Accessibility Configuration	5-11
Discounts System Configuration	5-12
Discount Options	5-12

Returns	5-13
Configuring Reason Codes	5-13
Reason Code Configuration Options	5-15
General Options	5-15
Inventory Adjustment Options	5-15
Paid In/Paid Out Options	5-15
Return Reason Code Options	5-16
Properties [Country Pack ONLY]	5-16
Configuring Menus and Tabs	5-16
Oracle Retail Xstore Point-of-Service Menu Configuration	5-17
About menu categories	5-17
Editing an Existing Menu	5-19
Changing the Menu Text	5-20
Removing a menu option	5-22
Changing a Menu Option Location	5-23
Adding a New Menu Option	5-24
Oracle Retail Xstore Point-of-Service Tab Configuration	5-27
Adding a New Tab	5-30
Removing a Tab	5-30
Moving a Tab Position	5-30
Changing a Tab Name	5-30
Menu System Configuration	5-31
Help	5-31
Register Configuration	5-31
Store Specific	5-31
Configuring Receipts	5-32
Finding the Receipt by Type	5-32
Finding the Receipt by Transaction	5-37
Changing the Receipt Logo	5-38
Receipt Configuration: System Configuration Options	5-38
Charity	5-39
Comission Options	5-39
Discount Options	5-39
Email Settings	5-39
Gift Receipts	5-40
Gift Registry	5-40
Inventory Location Based	5-40
Item Options	5-40
Kit Options	5-40
Layaway	5-41
Loyalty Options	5-41

Send Sale	5-41
Till Account	5-41
Training Mode	5-41
Transaction Behavior	5-41
Configuring Xstore Point-of-Service System Config Options	5-42
Using the System Config Search Feature	5-42
About Configuration Overrides	5-42
Viewing/Editing System Configurations	5-44
Configuring Oracle Retail Xstore Point-of-Service Security	5-47
Security Groups Setup	5-50
Security System Configuration	5-51
House Accounts	5-52
Sales	5-52
Security	5-52
Store Specific	5-54
Tender Options	5-54
Till Accountability	5-55
Warranty	5-57
Configuring Tenders	5-57
Tender Configurations	5-60
Basic Information	5-60
Denominations Information [DENOMINATION Tender Types Only]	5-61
Availability Information	5-62
Tender Options Maintenance	5-62
Tender Options Configuration	5-63
Usage Information	5-63
Customer Information	5-64
Authorization Information [AUTH tender types only]	5-64
Count Information [COUNT Tender Types Only]	5-65
Tender Security Settings	5-65
Tender Security Settings Configuration Options	5-67
General Information	5-67
Limits	5-67
Online Authorization Rules	5-67
Offline Authorization Rules	5-67
Refund	5-67
Tender Configuration: System Configuration Options	5-68
Charity	5-68
Closing Options	5-68
Discount Options	5-68
House Accounts	5-69

Opening Options	5-69
Returns	5-70
Store Specific	5-70
Tender	5-70
Tender Options	5-70
Till Accountability	5-71
Configuring Customer Displays	5-72
Deploying Configuration Changes	5-73
Scheduling a Planned Deployment	5-75
Scheduling a Single Deployment	5-76
Viewing Configuration Changes	5-77
Delete Configuration Changes	5-79
Delete Profile Configuration Overrides	5-79
Delete Store Specific Overrides	5-81
Copy Store Configurations	5-82
Deployment History	5-83
Deployed Versions	5-84

## 6 Data Management

---

About this Chapter	6-1
Where To Look For Additional Information	6-2
About Data Management	6-2
Managing Data	6-2
Data Manager Options	6-4
Items	6-5
Merchandise Items	6-6
Item Prices	6-9
Calculating the Price of an Item	6-11
Adding or Editing a Price	6-12
Attached Items	6-13
Adding an Attached Item	6-14
Editing An Attached Item	6-16
Merchandise Hierarchy	6-16
Editing a Merchandise Hierarchy Level	6-17
Adding to a Merchandise Hierarchy Level	6-19
Non-Merchandise Items	6-20
Item Matrix Manager	6-23
Assigning Matrix Colors To Merchandise Hierarchy And/Or Item Records	6-25
Changing the Sort Order	6-25
Specifying Merchandise Hierarchy And/Or Item Records As Hidden	6-26



Item Message Maintenance	6-26
Adding an Item Message	6-27
Editing an Item Message	6-29
Item Restrictions	6-29
Adding an Item Restriction	6-30
Editing an Item Restriction	6-31
Item Restriction Types	6-31
Searching for Item Restriction Types	6-32
Adding Item Restriction Types	6-32
Editing Item Restriction Types	6-33
Vendors	6-34
Employees	6-35
Taxes	6-38
Tax Elements	6-39
Tax Authorities	6-39
Tax Locations	6-40
Tax Groups	6-41
Tax Brackets	6-42
Tax Rates	6-43
Legal Entities	6-45
Communications	6-47
Store Messages	6-47
Employee Tasks	6-49
Exchange Rates	6-51
Stores	6-52
Viewing and Deploying the Data Changes	6-56
Viewing the Individual Changes in the Data Bundle	6-57
Data Publisher - Redeploying Data	6-58
Transferring Data	6-59
Managing the Organization Hierarchy	6-61
Defining Organization Hierarchy Levels	6-62
Adding an Organization Hierarchy Level	6-62
Editing the Description of an Organization Hierarchy Level	6-63
Deleting an Organization Hierarchy Level	6-63
Maintaining the Organization Hierarchy	6-63
Adding an Organization Hierarchy Level to a Node	6-64
Editing the Value and Manager Information	6-64
Adding Unassigned Stores to an Org Node	6-65
Creating a New Store and Add It to an Org Node	6-65
Deactivating an Org Node	6-65
Moving an Org Node	6-66

Deploying the Organization Hierarchy Changes	6-67
Creating and Maintaining Store Collections	6-67
Adding a Store Collection	6-68
Editing a Store Collection	6-68
Stock Valuation Year End Roll-Up	6-69
Overview	6-69
End-Of-Year Processing	6-69

## 7 Deployment Management

---

The Deployment Process at a Glance	7-1
About this Chapter	7-1
Uploading Files	7-2
File Upload: Removing an Uploaded File From the List	7-4
File Upload: Deploying a File or Files	7-4
Deployment: Using a Single Deployment	7-5
Deployment: Using a Deployment Plan	7-7
Creating a Deployment Plan	7-8
Deleting an Deployment Plan and Waves	7-13
Deleting a Wave from a Plan	7-13
Editing a Deployment Wave and Plan	7-13
Email Notifications	7-13
Viewing Deployments	7-15
Viewing Detail By Store	7-19
Approving a Wave	7-20
Unapproving a Wave	7-21
Purging Files	7-22
To Stop a Deployment	7-22
Cancelling a Deployment	7-23
Automatic External File Delivery	7-24
Setting File Delivery Details	7-25
Line Count [optional]	7-25
Download ID	7-25
Application Date	7-25
Target Org Node	7-25
Deployment Name	7-25
Download Time	7-26
Apply Immediately	7-26

## 8 Electronic Journal

---

About this Chapter	8-1
Using the Xcenter Electronic Journal	8-1

## 9 Reports

---

About this Chapter	9-1
Where To Look For More Information	9-1
Accessing and Running Oracle Retail Xstore Office Reports	9-1
Report Example	9-3
Available Reports By Category	9-3
Dashboard Report	9-3
Custom Reports	9-3
Flash Sales Reports Category	9-3
Sales Reports Category	9-4
Stock Valuation Report	9-4
Airport Reports	9-4
Transaction Audit Reports	9-4
Inventory Reports Category	9-4
Employee Schedule Reports Category	9-5
Customer Account Reports Category	9-5
Misc Reports Category	9-5
Dashboard	9-5
Dashboard Report Example	9-6

## 10 Support Tools

---

About this Chapter	10-1
Alert Console	10-2
About Alerts	10-2
Replication	10-3
Replication Logged Events	10-4
Connectivity	10-4
Connectivity Logged Events	10-5
About Xcenter Register Offline Alert Data	10-6
Application	10-6
Application Logged Events	10-7
Hardware	10-8
Hardware Logged Events	10-8
Updates	10-8
Updates Logged Events	10-9

Versioning	10-9
Versioning Logged Events	10-10
Alert Settings	10-10
Critical Alert Email Settings	10-11
To Set Up Critical Alert Email Recipient Addresses	10-12
Alert Threshold Settings	10-13
To Define Alert Threshold Settings	10-13
About Alert Severity Threshold Levels	10-14
Support Settings: Technical Information	10-15
xcenter.properties	10-15
cfg_critical_alert_email Table	10-15
ctl_event_logTable	10-16
cfg_alert_serverity_threshold Table	10-16
Deployed Oracle Retail Xstore Point-of-Service Versions	10-16
Oracle Retail Xstore Point-of-Service Version by Store Detail	10-17
PosLog Publisher	10-18
PosLog Publisher Search Results Page Layout Examples	10-21
Example 1: Trans Count < 100, Search Results < 5000	10-22
Example 2: Trans Count > 100, Search Results < 5000	10-22
Example 3: Trans Count > 100, Search Results > 5000	10-22
Temporary Store Server Management	10-23
Adding a Request	10-23
Approving/Rejecting a Request or Assigning a Server	10-25
Cancelling a Server Request	10-25
Replication Status	10-26

## A Appendix: About Deployments

---

Application Roles	A-1
Oracle Retail Xstore Office	A-1
Xcenter (a part of Oracle Retail Xstore Office)	A-1
Oracle Retail Xstore Point of Service	A-2
Oracle Retail Xenvironment	A-2
Apache (httpd)	A-2
DataLoader	A-2
Overview: How Files Are Managed	A-2
File Download to Stores	A-3
File Upload from Stores	A-3
Overview: About The Deployment Manifest	A-3
Sample Deployment Manifest	A-4
Examples: Deployment Scenarios	A-5

Deploying an Uploaded File	A-5
Deploying a Data Manager Change	A-5
Deploying a Configuration Manager Change	A-5
Deploying a File Automatically	A-6
Version Tracking of Deployments	A-6
How a Deployment is Downloaded and Applied	A-7
Deployment: Basic Troubleshooting	A-8
Deployments not uploaded successfully to apache	A-8
Deployments not being downloaded and applied by xenvironment	A-8
Deployments downloaded and applied by xenvironment, no status information appears in xstore office	A-8

## B Appendix: Personality Maintenance and Config Paths

---

Config Path Retrieval Process	B-1
At Oracle Retail Xstore Point-of-Service Startup	B-2
Till/Register Data	B-2
Processing Overview	B-2
Xcenter Config Path Properties Assembly	B-3
Global Configuration Path Properties	B-3
xstore.config.path.global.extensions	B-3
xstore.config.path.base.features	B-3
Workstation Overrides Config Path Properties	B-5
xstore.config.path.workstation.overrides.X	B-5
xstore.config.path.overrides.store.Y	B-6
Oracle Retail Xstore Point-of-Service Config Path Assembly	B-6
If Not Using Xcenter to Get the Config Path	B-6
Oracle Retail Xstore Office Security Settings	B-6
Resource Bundle Path Consolidation	B-7
Database Tables	B-7

## C Appendix: User Interface Configurations

---

Reports Menu	C-1
To Reference a Specific Report on the Reports Menu	C-2
Home Page Menu	C-2
Home Page/Main Menu Options	C-2
To Configure the Options on the Home Page	C-3
Panel Information	C-3
Defining Tab Library Properties	C-3
Security Settings	C-4

## D Appendix: Enrollment with Cloud Services

---

Enrolling Xstore Office On-Premise with Retail Cloud Services	D-1
Configuring Xstore Office On-Premise with IDCS	D-1
Configuring Xstore Registers for IDCS	D-2
Enrolling Xstore Stores in Xstore Office Cloud Service	D-3

## E Appendix: Accessibility

---

## F Appendix: Xcenter Attamchent Export

---

Overview	F-1
Property Settings	F-1
Spring Settings	F-1
Configuring an Attachment Export	F-1

## G Appendix: Tax Service Integration Avalara

---

Overview	G-1
Avalara - Scheduled Quartz Jobs	G-1
xcenter.properties Settings	G-2

## H Appendix: Pay By Link (PBL) Integration with Adyen Payment Provider

---

Overview	H-1
Security Considerations	H-1
Tomcat	H-2
Jetty	H-2
Weblogic	H-3
Web Service Changes	H-3
Additional Details	H-3

## Glossary

---

# Send Us Your Comments

Oracle® Retail Xstore Office User Guide, Release 21.0

Oracle welcomes customers' comments and suggestions on the quality and usefulness of this document.

Your feedback is important, and helps us to best meet your needs as a user of our products. For example:

- Are the implementation steps correct and complete?
- Did you understand the context of the procedures?
- Did you find any errors in the information?
- Does the structure of the information help you with your tasks?
- Do you need different information or graphics? If so, where, and in what format?
- Are the examples correct? Do you need more examples?

If you find any errors or have any other suggestions for improvement, then please tell us your name, the name of the company who has licensed our products, the title and part number of the documentation and the chapter, section, and page number (if available).



## Note:

Before sending us your comments, you might like to check that you have the latest version of the document and if any concerns are already addressed. To do this, access the Online Documentation available on the Oracle Technology Network Web site. It contains the most current Documentation Library plus all documents revised or released recently.

Send your comments to us using the electronic mail address: [retail-doc\\_us@oracle.com](mailto:retail-doc_us@oracle.com)

Please give your name, address, electronic mail address, and telephone number (optional).

If you need assistance with Oracle software, then please contact your support representative or Oracle Support Services.

If you require training or instruction in using Oracle software, then please contact your Oracle local office and inquire about our Oracle University offerings. A list of Oracle offices is available on our Web site at <http://www.oracle.com>.

# Preface

The *Oracle® Retail Xstore Office User Guide* describes all available functions of Release 21.0

## Audience

This guide is for technical personnel who configure, maintain and support, or use Oracle Retail Xstore Office.

## Documentation Accessibility

For information about Oracle's commitment to accessibility, visit the Oracle Accessibility Program website at <http://www.oracle.com/pls/topic/lookup?ctx=acc&id=docacc>.

### Access to Oracle Support

Oracle customers that have purchased support have access to electronic support through My Oracle Support. For information, visit <http://www.oracle.com/pls/topic/lookup?ctx=acc&id=info> or visit <http://www.oracle.com/pls/topic/lookup?ctx=acc&id=trs> if you are hearing impaired.

## Related Documents

For more information, see the following documents in the Oracle Retail Xstore Point-of-Service Release Notes.

See the Oracle Retail Xstore Office 21.0 documentation library at the following URL:

<https://docs.oracle.com/en/industries/retail/index.html>

## Customer Support

To contact Oracle Customer Support, access My Oracle Support at the following URL:

<https://support.oracle.com>

When contacting Customer Support, please provide the following:

- Product version and program/module name
- Functional and technical description of the problem (include business impact)
- Detailed step-by-step instructions to re-create
- Exact error message received



- Screen shots of each step you take

## Review Patch Documentation

When you install the application for the first time, you install either a base release (for example, 21.0) or a later patch release (for example, 21.0.1). If you are installing the base release or additional patches, read the documentation for all releases that have occurred since the base release before you begin installation. Documentation for patch releases can contain critical information related to the base release, as well as information about code changes since the base release.

## Improved Process for Oracle Retail Documentation Corrections

To more quickly address critical corrections to Oracle Retail documentation content, Oracle Retail documentation may be republished whenever a critical correction is needed. For critical corrections, the republication of an Oracle Retail document may at times not be attached to a numbered software release; instead, the Oracle Retail document will simply be replaced on the Oracle Help Center (docs.oracle.com) Web site, or, in the case of Data Models, to the applicable My Oracle Support Documentation container where they reside.

This process will prevent delays in making critical corrections available to customers. For the customer, it means that before you begin installation, you must verify that you have the most recent version of the Oracle Retail documentation set. Oracle Retail documentation is available on the Oracle Help Center (docs.oracle.com) at the following URL:

<https://docs.oracle.com/en/industries/retail/index.html>

An updated version of the applicable Oracle Retail document is indicated by Oracle part number, as well as print date (month and year). An updated version uses the same part number, with a higher-numbered suffix. For example, part number E123456-02 is an updated version of a document with part number E123456-01.

If a more recent version of a document is available, that version supersedes all previous versions.

## Oracle Retail Documentation on the Oracle Help Center (docs.oracle.com)

Oracle Retail product documentation is available on the following web site:

<https://docs.oracle.com/en/industries/retail/index.html>

(Data Model documents can be obtained through My Oracle Support.)

## Conventions

The following text conventions are used in this document:

Convention	Meaning
<b>boldface</b>	Boldface type indicates graphical user interface elements associated with an action, or terms defined in text or the glossary.

<b>Convention</b>	<b>Meaning</b>
<i>italic</i>	Italic type indicates book titles, emphasis, or placeholder variables for which you supply particular values.
monospace	Monospace type indicates commands within a paragraph, URLs, code in examples, text that appears on the screen, or text that you enter.

# 1

## Getting Started

Oracle Retail Xstore Office is a web-based application used to administer corporate-based functions such as Oracle Retail Xstore Point-of-Service configuration setup and maintenance, file management for the Oracle Retail Xstore Suite, viewing the electronic journal, viewing store reports, monitoring Oracle Retail Xstore Point-of-Service versions in use at the store and register levels, and monitoring alerts. This guide is intended for technical personnel working with Oracle Retail Xstore Office and requires a working knowledge of Oracle Retail Xstore Point-of-Service POS, XML, SQL Server database, the Windows operating system, and the network system being used

### Note:

Because Oracle Retail Xstore Office UI color schemes and menu options are configurable, the page layouts and functions on your system may appear in a different order or have different text than examples shown in this manual. Since different browsers use different rendering engines, the browser you are using may also affect the way the screens are depicted on your system.

## Prerequisites

This guide assumes:

- You have the privilege-permission level to use Oracle Retail Xstore Office.
- Oracle Retail Xstore Point of Service and Xcenter Database (a part of Oracle Retail Xstore Office) are in use.
- You have purchased Oracle Retail Xstore Office.

## Browser Requirement

This section covers the Client System requirements and products supported for Oracle Retail Xstore Office.

### Note:

Oracle Retail assumes that the retailer has ensured its Operating System has been patched with all applicable Windows updates.

The following web browsers are supported:

- Mozilla Firefox
- Microsoft Edge

- Google Chrome (Desktop)

Microsoft has deprecated Internet Explorer 11 in Windows 10 and recommends using Edge as the default browser. Refer to the [Oracle Software Web Browser Support Policy](#) for additional information.



**Note:**

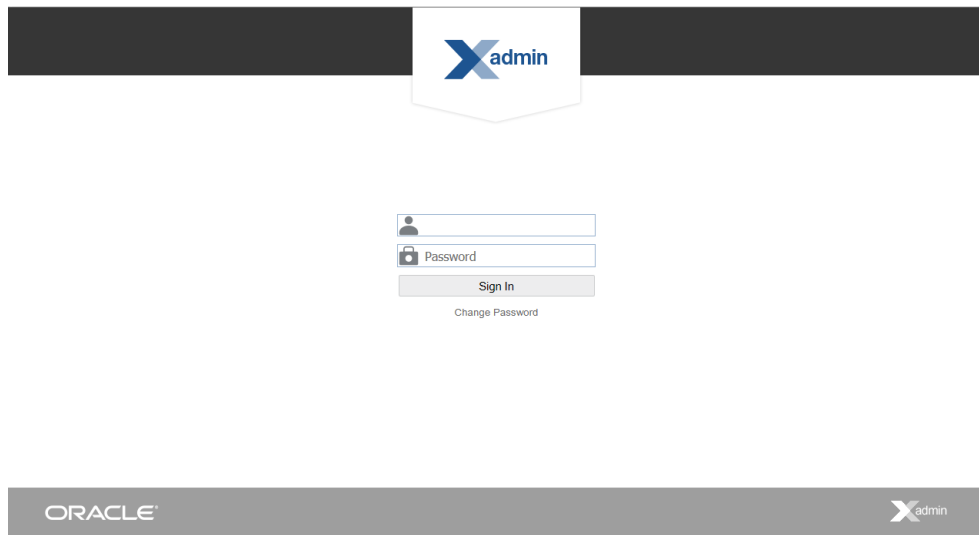
Oracle Retail Xstore Office must be set to 100% zoom.

## Accessing Oracle Retail Xstore Office

Oracle Retail Xstore Office is a web-based application that you can access through an internet browser.

1. Open an internet browser.
2. Enter the server address in the Address field and press **[Enter]**.
3. The login page opens.

**Figure 1-1 Oracle Retail Xstore Office Login Page**



**Note:**

The Forgot Password link is not available in a manually reset password environment and when using LDAP Authentication. You can only request a forgotten password reset in static and algorithm password environments. See [Requesting a Forgotten Password](#) for more information about resetting your password.

 **Note:**

The Xstore Office Login page is displayed in the Default Locale language when you log on for the first time or when you use a new browser. For more information on how to configure the language (default locale code) for Xstore Office, see the [General Category](#) General Category section in the [System Management](#) chapter.

4. Type your user name in the User ID field.
5. Type your password in the Password field.
6. Click the **Sign In** button.

 **Note:**

The first time you log in to Oracle Retail Xstore Office you will be prompted to change your password. Complete the fields as required, then click **Submit**.

7. You are prompted for an organization. Select an organization from the list and click **OK**.

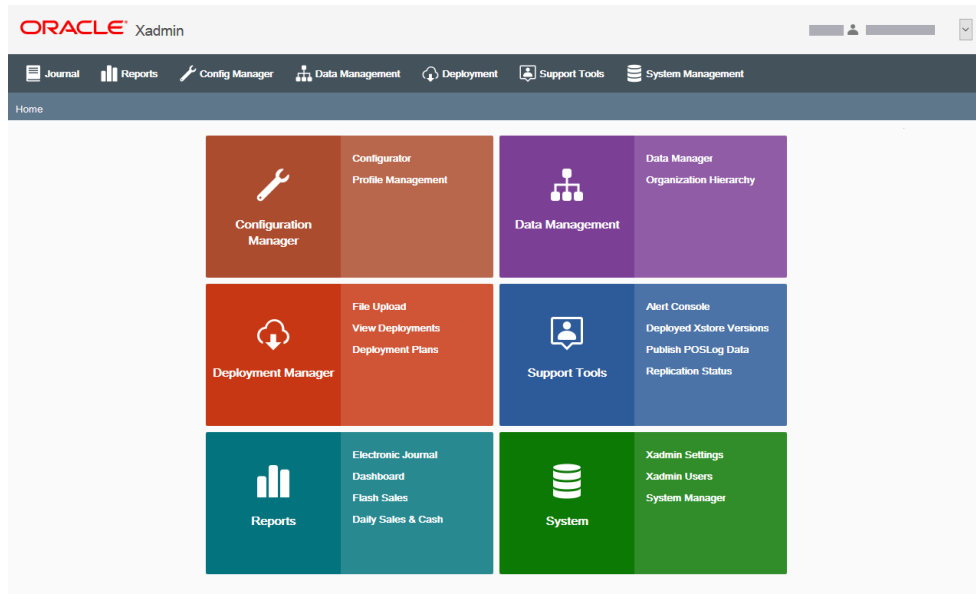
 **Note:**

If only one organization is assigned to your user account, the organization selection is not available.

If you select **Cancel** you are logged out of Xstore Office.

8. The Oracle Retail Xstore Office Home page displays. Select a menu option from the menu bar, or click a link in one of the Oracle Retail Xstore Office Panels to continue.

**Figure 1-2 Oracle Retail Xstore Office Home Page**



Home Page Layout:

**1. Menu Bar**

The top of the page contains the menu bar.

**2. Breadcrumbs Bar**

The breadcrumbs bar is right below the menu bar.

**3. Organization ID, Organization Name (if available) and Logged In User ID**

The selected organization ID and organization name (if available) as well as the logged in user ID are displayed in the top right corner of the page.

**4. Panels**

In the center of the page the available panels are displayed. Possible available panels are:

- Configuration Manager
- Data Manager
- Deployment Manager
- Support Tools
- Reports
- System

**5. More Arrow (when applicable)**

**6. Drop-down menu**

Select the logged in profile name in top right section of the page. A drop down menu is displayed. The following options are available:

- Log Out
  - Select the **Log Out** option.
  - Confirm that you want to log out. The system returns to the login page.

- Change Organization

Use the Change Organization option to switch between organizations.

 **Note:**

If the user has only access to one organization, the Change Organization option is not displayed.

- About Xadmin

Use this feature to view the Oracle Retail Xstore Office version the system is currently running on. This is a view-only window.

 **Note:**

To view the versions of Oracle Retail Xstore Point of Service running in the field, see [Support Tools](#).

The following information is shown:

- The application version number
- Copyright information
- Oracle license information

To close the window, click the Close icon.

Navigation:

- To return to the Oracle Retail Xstore Office Home page at any time, click the Home bread crumb.
- To display more panels (when applicable), click the **More** arrow.

 **Note:**

#### Initial Access Setup Instructions

A default administrator security role account has been set up in the database to allow first-time access to Oracle Retail Xstore Office.

Using this default user account to log in, click the Xadmin Users link in the System panel or select Xadmin Users in the System menu to set up additional Oracle Retail Xstore Office user accounts.

Oracle recommends that you set up at least one ADMINISTRATOR security user account.

Once this Administrator security user has been set up, delete the initial (default) administrator user account for security purposes.

See [Roles, Users, and Security Access](#) for detailed instructions.

## Changing Your Password



### Note:

This change password option is not available if you are using LDAP authentication.

To change the password of another user, see [Roles, Users, and Security Access](#), Editing Oracle Retail Xstore Office User Accounts.

1. To change your password, click the Change Password link on the Oracle Retail Xstore Office Login window ([Figure 1-1](#)).
2. At the Change Password window, enter the information as required and click **Submit**.
3. The Oracle Retail Xstore Office Home page displays and your new password is now in effect.

## Requesting a Forgotten Password

Use the Forgot Password link to request a password reset through email.



### Note:

This option is not available in a manually reset or LDAP password environment. See [Roles, Users, and Security Access Password Options - Non LDAP](#) and [LDAP Authentication](#) for more information about password environments in Oracle Retail Xstore Office.

1. At the Login window, or the Change Password window, click the **Forgot Password** link.
2. When prompted, enter your User ID and email address, then click **OK**.
3. Oracle Retail Xstore Office sends an email to your email address containing a temporary password.
4. When prompted, enter your User ID and the temporary password contained in the email, then click **Sign In**.
5. At the Change Password window, enter the temporary password in the Current Password field, then enter and confirm your new password.
6. Click **Submit**. The Oracle Retail Xstore Office Home page displays.

## About this Guide

Refer to the following chapters for the information you need to use the Oracle Retail Xstore Office components:



- [Roles, Users, and Security Access](#) - This chapter provides information about creating user security roles and managing user access to Oracle Retail Xstore Office.
- [System Management](#) - This chapter provides information about the features used to manage the Oracle Retail Xstore Office application, including setting up the system configuration rules and paths for Oracle Retail Xstore Office itself.
- [Profile Management](#) - This chapter provides information about creating and maintaining profile groups and elements for stores, creating and maintaining the personalities that determine the prioritized profile elements for configuration overrides, and creating and maintaining the store landscapes used for machine (register) configurations. After setting up the groups/elements and personalities/landscapes, this chapter explains how to use the information to create Store Personalities for your stores which allows you to easily maintain portions of your configuration paths.
- [Configurator](#) - This chapter provides information about creating, maintaining, and deploying Oracle Retail Xstore Point-of-Service configuration changes selectively, or globally across the entire organization.
- [Data Management](#) - This chapter provides information about creating, maintaining, and deploying Oracle Retail Xstore Point-of-Service data changes selectively, or globally across the entire organization.
- [Deployment Management](#) - This chapter provides information about using Deployment Manager to upload files for deployment and to track the status of all configuration, data, and file deployments.
- [Reports](#) - This chapter provides information about running and viewing any of the Oracle Retail Xstore Point-of-Service reports against the Xcenter (central) database.
- [Support Tools](#) - This chapter provides information about using the Support Tools component to view issues taking place at the store level, to set up email alerts to be sent to the appropriate personnel when any issues occur, and to compile the PosLog data from within Oracle Retail Xstore Office and save it as a file to a specified location or to rebroadcast the PosLog data.
- [Appendix: About Deployments](#) - This appendix explains how deployments are created by Oracle Retail Xstore Office and applied by Oracle Retail Xstore Point of Service and Oracle Retail Xenvironment.
- [Appendix: Personality Maintenance and Config Paths](#) - This appendix explains how the store personalities set up in Oracle Retail Xstore Office are used to create the config path properties.
- [Appendix: User Interface Configurations](#) - This appendix explains how Oracle Retail Xstore Office can be "personalized" by adding a background image, changing the color scheme, and configuring the panel display order and content.
- [Appendix: Enrollment with Cloud Services](#), - This appendix describes how to enroll Xstore Office On-Premise with cloud services.
- [Glossary](#) - This glossary lists and defines many terms and their definitions used in this guide.

# 2

## Roles, Users, and Security Access

This chapter provides information about creating user security roles and managing user access to Oracle Retail Xstore Office. The User Roles and Users and Security Access features provide the ability to create security roles and to grant privileges to users for one or more areas of Oracle Retail Xstore Office based on these roles.



### Note:

#### Security

Any users in an Org Node higher than the logged-on user will not be displayed in the Admin Users list. In addition, the logged-on user cannot add Org Nodes that are higher than the org nodes he/she is assigned to. Security privileges are associated with Oracle Retail Xstore Office actions.

## Oracle Retail Xstore Office Areas Controlled by Security

- Administration
- Configurator
- Data Manager
- Deployment Manager
- Home Page
- Reports
- Support

## About this Chapter

This chapter contains the following sections:

- See [User Roles](#) for information about creating the roles used to determine user privileges in Oracle Retail Xstore Office. Access to different areas of Oracle Retail Xstore Office is controlled by assigning security Roles to the users.
- See [Admin Users - Using Roles to Grant Access to Oracle Retail Xstore Office](#) for instructions on creating new Oracle Retail Xstore Office User Accounts and controlling user access to Oracle Retail Xstore Office.

 **Note:**

Refer to the Oracle Retail Xstore Suite Implementation and Security Guide for information about using DataLoader to load Oracle Retail Xstore Office user accounts.

- See [Editing Oracle Retail Xstore Office User Accounts](#) for instructions on changing an existing user's account privileges.
- See [Password Options - Non LDAP](#), [Editing Oracle Retail Xstore Office User Accounts](#), [Passwords: Special Characters & Rules](#) and [Resetting a User's Password](#) for instructions on setting up, changing, or resetting a user's password.

 **Note:**

If using LDAP Authentication, refer to [LDAP Authentication](#). LDAP-managed users do not have the ability to manage their passwords from within Oracle Retail Xstore Office, or the ability to use the password reset or password change functionality.

## User Roles

 **Note:**

The Role of ADMINISTRATOR is required. This role defaults to access for every privilege and has a rank of 150.

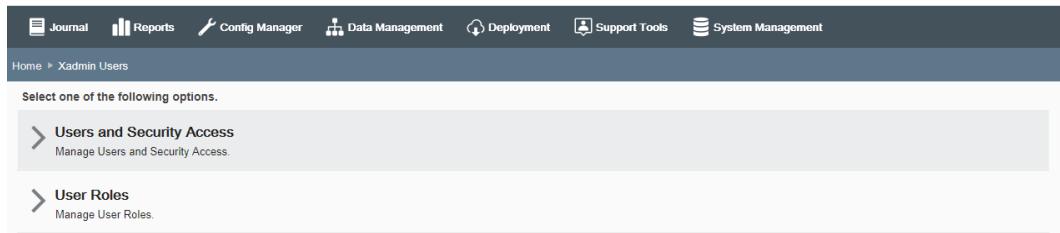
Oracle recommends that you set up at least one ADMINISTRATOR user. Once this administrator user has been set up, delete the initial (default) administrator user account for security purposes.

Access to different areas of Oracle Retail Xstore Office is controlled by assigning security Roles to the users. This section provides information about defining the user roles that will then be used to grant specific privileges to a user.

## Creating/Editing User Roles

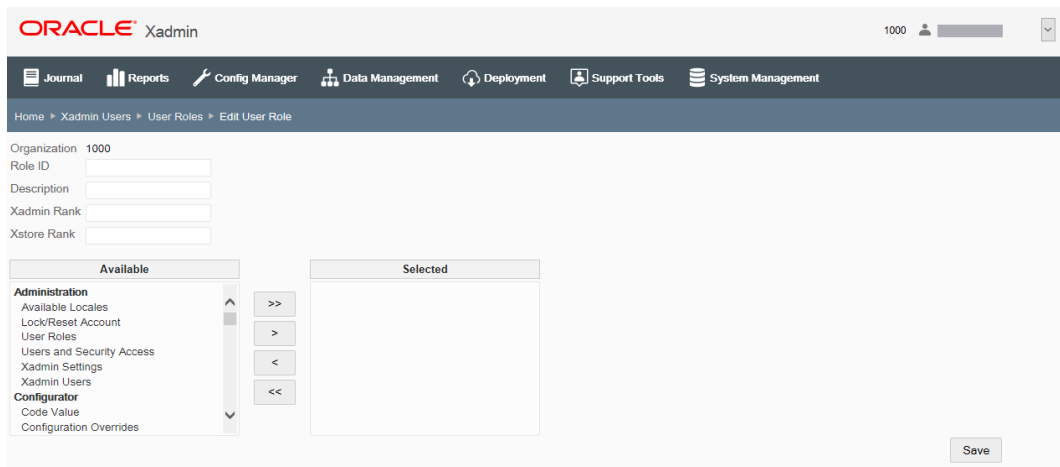
1. From the Oracle Retail Xstore Office menu, select **System**, then **Xadmin Users**, or click the Xadmin Users link in the System panel.
2. At the Xadmin Users page, click **User Roles**.

**Figure 2-1 Xadmin Users Page**



3. At the User Roles page, create a new User Role, edit an existing User Role, or delete an existing User Role:
  - To create a new Role, click **Add New**. The User Roles window displays and the fields are blank.
  - To edit an existing User Role, select the Role from the list. The User Roles window displays and the fields are populated with the current Role information.
  - To delete a User Role, select the Delete icon (X).
4. Complete the required fields. (All fields are required.)

**Figure 2-2 User Roles Window - Add New Role Example**

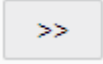
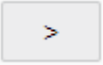
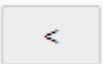
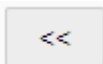


- **Organization** - Select the Organization ID and name from the list.
- **Role ID** - Type the role identifier. Spaces and special characters are not allowed in this field. When editing an existing role, this field cannot be changed.
- **Description** - Type a description for the role.
- **Xadmin Rank** - Type a numeric rank number for Oracle Retail Xstore Office. This rank is evaluated when creating a new Oracle Retail Xstore Office user in User and Security Access. An Oracle Retail Xstore Office user cannot assign a role to a new user that has a greater numeric rank than his/her Xadmin rank. For example, a logged-in user with a rank role of 50 cannot edit or create a rank role of 51 and above.
- **Xstore Rank** - Type a numeric rank number for Oracle Retail Xstore Point of Service. This value is the rank associated to the user within the Oracle Retail Xstore Point-of-Service application and corresponds to the role the user holds within Oracle Retail

Xstore Point of Service. This rank is evaluated when creating or editing an Oracle Retail Xstore Point-of-Service employee in Data Manager - Employees. An Oracle Retail Xstore Office user cannot assign Oracle

Retail Xstore Point-of-Service security groups to an employee that is ranked higher than his/her Oracle Retail Xstore Point-of-Service rank.

- **Privileges** - Select each role privilege from the list of Available options and click the arrow button to move the role or roles to the Selected window:

-  Double right arrows - Add all privileges to the Selected window.
-  Single right arrow - Add selected privilege to the Selected window.
-  Single left arrow - Remove selected privilege from the Selected window.
-  Double left arrows - Remove all privileges from the Selected window.
- To select several privileges at the same time, hold down the **[Ctrl]** key on the keyboard while selecting each privilege you want to assign to the role you are creating or editing. Click the single right arrow button to move the privileges from the Available window to the Selected window.
- You can also hold down the **[Shift]** key in the same manner to select all the privileges between the first privilege you select and the last privilege you select. Click the single right arrow button to move the privileges from the Available window to the Selected window.

5. Click **Save** to create or update the role.

 **Note:**

A Delete icon (X) is available for roles you create. However, if a role has been assigned to a user it cannot be deleted.

## About Privileges

The available privileges for Oracle Retail Xstore Office are grouped by category: Administration, Configurator, DataManager, DeploymentManager, Home Page, Reports, and Support.

Make sure you set up Oracle Retail Xstore Office privileges properly.

- For example, in Deployment Manager, the Deployment Plan privileges for View Deployment Plans and Create/Edit Deployment Plans technically work together. If you just have View privilege, you can only view deployment plans (as expected).

However, you must have both privileges (view and create) in order to Create or Edit.

- The same is true for the Configurator privileges. If you just have Discounts or Menus and so on., you cannot do anything. You must also have the Configurator privilege and the Global Configurations or Configuration Overrides privilege to be able to get to the Discounts/Menus/Receipts selection page.
- If a user does not have the privilege for a specific home page panel, then it will not be displayed when the user logs into Oracle Retail Xstore Office. There are six panels in the Oracle Retail Xstore Office base configuration, so there are six privileges available. Also, if the user has access to the home page panel itself, but not to any of the options contained within it, then the panel will not be displayed.

## Administration

Administration Security Privileges:

- Available Locales
- Credentials Storage
- Lock/Reset Account
- Store Authorization Manager
- Store Enrollment
- System Manager
- User Roles
- Users and Security Access
- Xadmin Settings
- Xadmin Users
- Xoffice Cloud Store Enrollment

## Configurator

Configurator Security Privileges:

- Code Value
- Configuration Overrides
- Configurator
- Copy Store Configurations
- Customer Displays
- Delete Profile Element Configurations
- Discounts
- Global Configurations
- Landscape Maintenance
- Menu Configuration
- Menus
- Personality Maintenance

- Profile Maintenance
- Profile Management
- Reason Codes
- Receipts
- Schedule Deployment
- Security
- Security Groups
- Security Privileges
- Store Personality Maintenance
- Store Specific Overrides
- System Config
- Tab Configuration
- Tender Maintenance
- Tender Options Maintenance
- Tender Security Settings
- Tenders

## Customization

- Delete Customization
- Export Customization
- Upload Customization

## DataManager

DataManager Security Privileges:

- Attached Items
- Avalara Tax Data Refresh
- Currency Exchange
- Data Manager
- Manager Deployment
- Data Publisher
- Employee
- Employee Tasks
- Item Matrix Manager
- Item Message Maintenance
- Item Pricing
- Item Restriction Types

- Item Restrictions
- Items
- Legal Entity [Country Pack ONLY]
- Merchandise Data Refresh
- Merchandise Hierarchy
- Merchandise Items
- Non Merchandise Items
- Organization Hierarchy
- Organization Hierarchy Levels
- Organization Hierarchy Maintenance
- Store Collections
- Store Communications
- Store Messages
- Stores
- Tax Authority
- Tax Brackets
- Tax Elements
- Tax Group
- Tax Location
- Tax Rates
- Taxes
- Vendor

## DeploymentManager

DeploymentManager Security Privileges:

- Approve Deployment Wave
- Cancel Deployment
- Create/Edit Deployment Plans
- File Deploy
- File Upload
- Purge Deployment Files
- Schedule Planned Deployment
- Schedule Single Deployment
- Unapprove Deployment Wave
- Upload File to Deploy
- View Deployment Plans
- View Deployments





**Note:**

The File Deploy privilege should not be assigned to the same role as either the File Upload or Upload File to Deploy privilege.

## Home Page

Home Page Panel Security Privileges:

- Home Page
- Home Page Config Management Panel
- Home Page Data Management Panel
- Home Page Deployment Panel
- Home Page Reports Panel
- Home Page Support Panel
- Home Page System Panel

## Reports

Reports Security Privileges:

- Airport Authority Report
- Best Sellers Reports
- Credit Card Report
- Customer Account Activity Summary Report
- Customer List Report
- Daily Sales Report
- Daily Sales Total Report
- Daily Sales and Cash Report
- Dashboard Report for Sale
- Electronic Journal
- Employee Performance Report
- Employee Tasks Report
- Flash Sales Report
- Gift Certificate Report
- Inventory Stock Cost Report
- Item List Report
- Journal Report
- Layaway Account Activity Report
- Layaway Aging Report

- Line Void Report
- No Sale Report
- Post Void Report
- Post Void Summary Report
- Price Change Report
- Price Override Report
- Receiving Exception Report
- Receiving Report
- Returned Merchandise Report
- Roll-up Stock Valuation Report
- Sales by Department Report
- Sales by Department and Employee Report
- Sales By Hour Analysis Report
- Sales By Hour Report
- Shipping Exception Report
- Special Orders Report
- Stock Valuation Reports
- Store Locations Report
- Suspended Transaction Detail Report
- Suspended Transaction Summary Report
- Tax Exemption Report
- Transaction Cancel Detail Report
- Transaction Cancel Summary Report
- View Reports

## Support

Support Security Privileges:

- Alert Console
- Alert Settings
- Deployed Oracle Retail Xstore Point-of-Service Versions
- PosLog Publisher
- Temporary Store
- Replication Status

# Admin Users - Using Roles to Grant Access to Oracle Retail Xstore Office

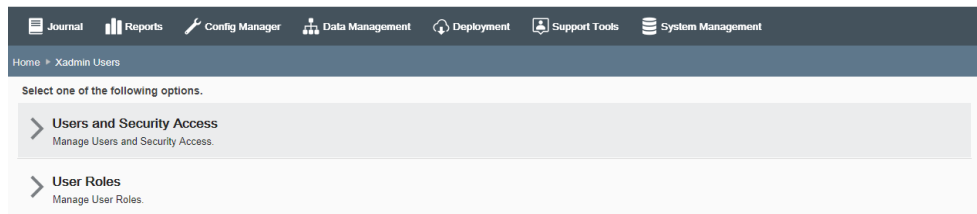
Once you have created Roles, you can grant user access to Oracle Retail Xstore Office by assigning a Role, and its associated privileges, to the user.

## Creating New Oracle Retail Xstore Office User Accounts

Perform the following steps to grant other users access to Oracle Retail Xstore Office components. To change an existing user's account privileges, see [Editing Oracle Retail Xstore Office User Accounts](#).

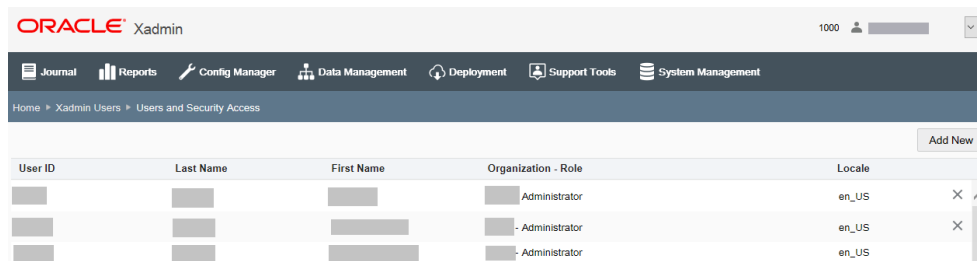
1. From the Oracle Retail Xstore Office menu, select **System**, then **Xadmin Users**, or click the Xadmin Users link in the System panel.
2. At the Xadmin Users page, click **Users and Security Access**.

**Figure 2-3 Xadmin Users Page**



3. At the Users and Security Access page, click **Add New** to create a new user account.

**Figure 2-4 Users and Security Access Page**



 **Note:**

If there are more than 200 Oracle Retail Xstore Office users in your organization, a Search page displays rather than the employee list as shown in Figure 2-5 above. Click **Add New** to create a new user account.

4. Enter the information as required to grant security privileges for new users:

- a. **User ID** - REQUIRED

 **Note:**

The User ID Minimum Length is set in **System - Xadmin Settings - User Account**.

- b. **Authentication Type** - If applicable, select the authentication type, Internal Xadmin directory or LDAP directory.

 **Note:**

Authentication Type is only available if LDAP authentication is enabled. If using LDAP Authentication you are not prompted for password information. Also, password reset and password change functionality is not available. See [LDAP Authentication](#) for more information.

- c. **First Name** - REQUIRED

- d. **Last Name** - REQUIRED

- e. **Password & Confirm Password** - REQUIRED FOR MANUAL PASSWORD METHOD See [Passwords: Special Characters & Rules](#) for more information about password validation.

 **Note:**

The Password and Confirm Password fields are not available if using the Static password method or the Algorithm method when creating new user accounts. See [Password Options - Non LDAP](#) for more information about static passwords and algorithm passwords.

- f. **Locale** - This list contains the available locales defined for your organization; defaults to English United States.
  - g. **Email** - Enter the user's email address, if applicable.
  - h. **Account Locked** check box - After a configurable number of consecutive unsuccessful login attempts, the user's account will be automatically flagged as locked and the user cannot access the system until you reset the lock flag here. You can also select this check box to lock a user out of the system. This functionality is not available for LDAP users.
5. Click **Add New**, to add users organization, role and org nodes. The system displays the Add users organization, role and org nodes window. Select the following.
    - a. **Organization** - Select the organization ID the user has access to from the list.
    - b. **Role** - Select a role for the user.
    - c. **Organization Nodes** - Specify which stores the user has access to:

- Select the globe icon. The system displays a list of organization nodes defined for your organization.
- Select which nodes/stores the user will have access to, and click **Add**. The system displays the selected organization nodes.
- The nodes you selected are shown, along with a **Delete** option you can use if you need to remove access to an Organization Node for the user.

 **Note:**

You can add and delete multiple organization nodes.

- d. **Enable dashboard as home page** check box - Select the check box to enable the Dashboard as your home page.

 **Note:**

The Dashboard can only be enabled as home page, when a single store node is assigned to the user.

- e. Click **OK** to save your entries. The system displays the User screen and updates the list of assigned organizations for the user.

 **Note:**

Multiple organizations and roles can be added to the same user by clicking **Add**.

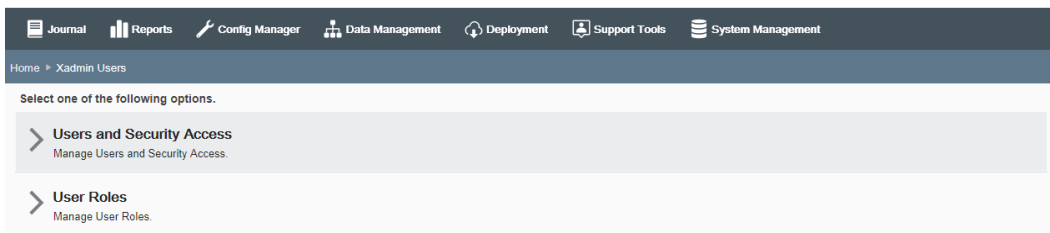
6. Click the **Save** button to create the new user account.

The new user account is added to the list of Oracle Retail Xstore Office Users. When the new user logs in to Oracle Retail Xstore Office, only the components for which the user has been granted access will be active on the Oracle Retail Xstore Office menu and panel links.

## Editing Oracle Retail Xstore Office User Accounts

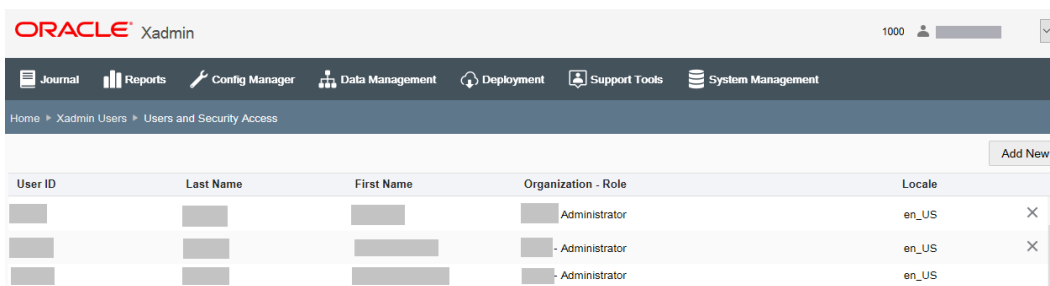
1. From the Oracle Retail Xstore Office menu, select **System**, then **Xadmin Users**, or click the Xadmin Users link in the System panel.
2. At the Xadmin Users page, click **Users and Security Access**.

**Figure 2-5 Xadmin Users Page**



3. At the Users and Security Access page, select a user account from the list.

**Figure 2-6 Users and Security Access Page**



**Note:**

If there are less than 200 Oracle Retail Xstore Office users in your organization, the list of users will be shown automatically without requiring a search. Otherwise, enter search criteria to find an Oracle Retail Xstore Office user account.

**Note:**

A delete option is available to allow you to remove an Oracle Retail Xstore Office user account. If selected, you will be prompted to confirm the user account should be deleted. Always make sure at least one user has access to the ADMINISTRATOR role before deleting user accounts.

**Note:**

Xstore will not be deleting any users in Xadmin as part of the Right to be Forgotten Data Privacy effort. Xadmin users will need to be deleted in a separate process triggered by you, the retailer.

4. The Edit User page provides the fields that can be edited for the selected user account. Refer to step 4 on page 9 for more information about the fields.

About editing fields:

- The User ID cannot be changed.
  - The Authentication Type cannot be changed after setup.
  - When editing existing users, a **Reset Password** option is available for static and algorithm password methods. See [Resetting a User's Password](#).
  - If you changed the Security Role setting, the user's access to Oracle Retail Xstore Office components is updated accordingly. When the user logs in to Oracle Retail Xstore Office, only the components for which the user has been granted access will be active on the Oracle Retail Xstore Office menu and panel links.
5. Click **Save** to apply the changes to the user's account.

## Password Options - Non LDAP

There are three options for creating passwords for new users and/or users that request a password reset. These configuration options are set in Xadmin Settings. See [System Management](#), Oracle Retail Xstore Office Configuration for more information about setting up password options.

- **Manual Setup** - Using this option, the administrator creates each password and then communicates it to the user. When creating a new user, the Password text box must be populated with a password that meets the standards set by other Oracle Retail Xstore Office password configurations defined in Xadmin Settings, User Accounts section.
- **Static Passwords** - Using this option, the administrator first sets up a static (universal) password within Oracle Retail Xstore Office Settings for all new users, for example A@23456. This static password will be temporarily used by new Oracle Retail Xstore Office users, and users that have requested a password reset. A Password text box is not needed on the Edit User page since a static password is used for all new users. The Oracle Retail Xstore Office user will be prompted to change this password the first time he/she logs into the system.
- **Auto-generated Password Via Algorithm** - Using this option, the password is created automatically for the user based on a predetermined algorithm. The algorithm contains aspects of the user profile that can be communicated easily. The algorithm currently used is as follows:
  - The first letter of the user's first name (upper case).
  - The first letter of the user's last name (lower case).
  - The @ symbol.
  - The month and year in which the user record is created (when the password is requested) in MMYYYY format.

The Oracle Retail Xstore Office user will be prompted to change this password the first time he/she logs into the system.

## Passwords: Special Characters & Rules

**Table 2-1 Valid Password Special Characters**

Character	Description
!	exclamation mark
#	pound or number sign
\$	dollar
%	percent
&	ampersand
(	open parenthesis
)	close parenthesis
*	asterisk
-	minus or hyphen
=	equal
?	question mark
@	at
[	open bracket
]	close bracket
^	carat
_	underscore
{	open brace
}	close brace
	pipe or bar
~	tilde
+	plus

**Table 2-2 Invalid Password Special Characters**

Character	Description
'	apostrophe or single quote
`	back quote
\	back slash
:	colon
,	comma
>	greater than
.	period
"	quote
;	semi-colon
/	slash or forward slash



## Password & User ID Configuration

Password & User ID settings are configured in **System - Xadmin Settings - User Account** category. These settings include the following:

**Method of Creating Password for New Users** - The method used to create the password for newly added users. See [Password Options - Non LDAP](#) for more information about the three options available.

**Number of Capital Letters Required for a Password** - The minimum number of capital letters that should appear in a password. The minimum number is zero (0).

**Number of Changes Before a Password Can Be Reused** - The number of password resets within which associates are not allowed to reuse the same password. For example, setting the value to 12 ensures a user's new password cannot match any of his/her 12 previous passwords. A setting of zero (0) means that the same password can always be reused.

**Number of Consecutive Characters Allowed in a Password** - The maximum number of times that any given symbol or character can repeat consecutively within the password string. The minimum number is one (1).

**Number of Login Attempts Before Account Is Locked** - The number of times an invalid password can be entered before the account is locked. The minimum number is one (1).

**Number of Numbers Required for a Password** - The minimum number of digits that should appear in a password (accepted values = 0-9). The minimum number is zero (0).

**Number of Special Characters Required for a Password** - The minimum number of special characters that should appear in a password. The minimum number allowed is zero (0). See [Passwords: Special Characters & Rules](#) for a list of valid special characters.

**Password Expiration Days** - The number of days that a password can be used before it expires. If a user successfully logs into Oracle Retail Xstore Office (enters valid user name and password), but the password is older than the configured number of days, the user will be rerouted to the Change Password screen and will not be able to access the system until the password has been successfully changed.

**Password Length** - The minimum length of a password. If a value of 1 is set, passwords have no minimum length, but cannot be empty/blank.

**User ID Length** - The minimum number of characters that must be used in order for a user ID to be valid.

See [System Management](#) for more information about the password configuration options.

## Additional Password Requirements

- A user's password cannot be the same as his/her user ID.
- Passwords cannot contain null or whitespace characters (space, tab, carriage return, \0, for example). Note that leading or trailing null and whitespace characters are silently trimmed by the UI automatically.

## Resetting a User's Password

Use the Reset Password function to manually reset user passwords when needed. This option is available with Static and Algorithm password generation methods only.

 **Note:**

If Oracle Retail Xstore Office is configured for Manual password generation, simply change the password in the Password field on the Edit User page:

- If you reset your own password, it will not be marked as temporary in Oracle Retail Xstore Office.
- If you (the administrator) manually reset another user's password, it will be marked as temporary in Oracle Retail Xstore Office and the user must change it during the next login.

1. From the Oracle Retail Xstore Office menu, select **System - Xadmin Users**, or click the Xadmin Users link in the System panel.
2. At the Xadmin Users page, click **Users and Security Access**.
3. At the Users and Security Access page, select a user account from the list.
4. Click the Reset Password link.
5. When prompted, verify the user account and email address are correct, then click **Yes** to continue.

 **Note:**

If the user does not have an email address on record, you will be prompted whether or not to continue. Click **No** to return to the Edit User page and enter an email address, or click **Yes** to continue without generating an email for the user.

6. The password is reset based on the configured password method, either the static (universal) password or the algorithm password. An email is generated and sent to the Oracle Retail Xstore Office user with the details.

## LDAP Authentication

LDAP Authentication allows users to log into Oracle Retail Xstore Office using a single sign-on where one password for a user is shared between many services. This feature uses LDAP (Lightweight Directory Access Protocol) and Microsoft's AD (Active Directory) repository to manage the user ID and password access to the application.



**Note:**

LDAP is used for authentication to Oracle Retail Xstore Office, but the user information must be set up in the Oracle Retail Xstore Office database for the users to access the application.

## Assumptions and Requirements for LDAP Users

- LDAP - managed users do not have the ability to manage their passwords from within Oracle Retail Xstore Office, or the ability to use password reset or password change functionality.
- A single LDAP server must be configured for the Oracle Retail Xstore Office instance. Multiple LDAP authentication servers are not supported.
- Account locking (for example, after "X" login attempts) and unlocking is not available through Oracle Retail Xstore Office. It may be available through the LDAP server.

## Additional Details for LDAP Authentication

- The server must be a domain controller, for example, `ldap://localhost:389`.
- Add a user in the Active Directory Users and Computers section of the Server Manager. For example, add the user to the folder Client Services of the main branch.
- When setting up the user, the password entered, is the same password for logging on to Oracle Retail Xstore Office with this user.

## Oracle Retail Xstore Office LDAP Settings

LDAP Authentication settings are configured in **System - Xadmin Settings - User Account** category.

**Default Domain Name for LDAP** - The default domain name to be used when authenticating users using LDAP.

**Enable LDAP Authentication Option?** - The configuration used to enable Oracle Retail Xstore Office to authenticate users using LDAP directory.

**LDAP Provider URL** - The URL to be used to connect to LDAP server.

# 3

## System Management

The System component has many features used to manage the Oracle Retail Xstore Office application itself, including setting up the system configuration rules and paths, setting up the available locales within Oracle Retail Xstore Office, viewing Oracle Retail Xstore Office version information, and setting up Oracle Retail Xstore Office users and user roles.

### About this Chapter

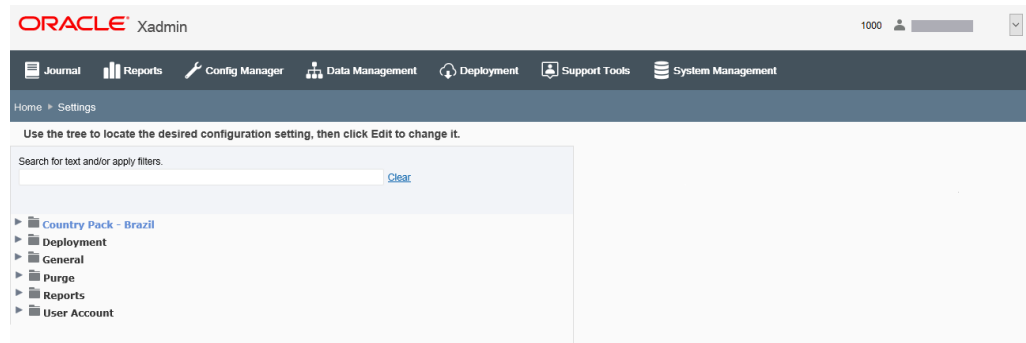
- For information about the Oracle Retail Xstore Office system configuration feature, see [Oracle Retail Xstore Office Configuration](#). This section provides detailed information about setting configuration parameters for the Oracle Retail Xstore Office application itself.
- For more information about how to manage system management options, see [System Manager](#).
- For more information about the Store Authorization Manager option, see [Store Authorization Manager](#).
- For information about controlling the available locales within the Oracle Retail Xstore Office application itself, see [Available Locales](#). These changes are not sent down to Oracle Retail Xstore Point of Service.

### Where To Look For User Settings Information

- For information about the Users and Security Access component, see [Roles, Users, and Security Access](#). This component provides the ability to grant privileges to users for one or more areas of Oracle Retail Xstore Office as needed based on security Roles.
- For information about the User Roles component, see [Roles, Users, and Security Access](#). This component provides the ability to create the security roles that are used to control access to the various areas of Oracle Retail Xstore Office.

### Oracle Retail Xstore Office Configuration

Oracle Retail Xstore Office Configuration provides the ability to set up the configuration options that govern how Oracle Retail Xstore Office works. You cannot add or delete Oracle Retail Xstore Office configuration options.

**Figure 3-1 Xadmin System Settings**

1. From the Oracle Retail Xstore Office menu, select **System Management**, then **Xadmin Settings**, or click the Xadmin Settings link in the System panel.
2. The Settings page displays, showing the configuration options available for Oracle Retail Xstore Office. The configuration options are arranged by category, in a tree view. Edit the values as needed, then click the **Save** button to save the changes.

To find configurations containing specific text, enter the search text in the input box, then press **[Enter]**. The text typed here can be found anywhere within the configuration label or description. The results are shown in the left panel (folder tree). Only those configurations containing the specified text within the label and/or description are displayed. If needed, click **Clear** to remove the search criteria and return to the Oracle Retail Xstore Office Configuration page.

See [Oracle Retail Xstore Office Configuration](#) below for detailed information about the Oracle Retail Xstore Office configuration options.

## Oracle Retail Xstore Office Configuration Options

This section describes the Oracle Retail Xstore Office Configuration Options.

### Country Pack - Brazil

- **Days Back for SPED Export**

The SPED (Sistema Público de Escrituração Digital) export process creates the Brazilian SPED report for a single day. To allow for any delays in replication, the report is generated on a delay. This configuration specifies the number of days to wait before generating the report for a specific date. The task creates a daily XML file for each shop. Each XML file is made available for download through the File REStful resource. For more details on the File resource, see Xstore Office Services in the Oracle Retail Xstore Suite Services Guide.

### Deployment Category

- **Automatically Deploy Data Manager Changes?**

If set to true, Oracle Retail Xstore Office automatically deploys pending Data Manager changes at a specified time each day. The time of day is determined by the Data Manager Automatic Deployment Time setting.

- **Data Manager Automatic Deployment Time**

The time of the day to start the auto deployment of undeployed Data Manager changes. The time should be in the format of HH:MM using the 24 hr clock. This setting is only relevant when the Automatically Deploy Data Manager Changes? setting is enabled.
- **Deployment Download Connection Timeout**

The amount of time, in seconds, that Oracle Retail Xenvironment will spend attempting to connect to Xcenter (part of Oracle Retail Xstore Office) to download a deployment. Once the time has elapsed with no connection detected, the attempt will be considered a failure. This setting is used by Oracle Retail Xenvironment at the store.
- **Deployment Download Retries**

The number of times Oracle Retail Xenvironment will attempt to download updates from Oracle Retail Xstore Office before failing. The default value is 10 attempts. A setting of zero (0) means never retry, which is not recommended. This setting is used by Oracle Retail Xenvironment at the store.
- **Deployment Download Retry Interval**

The time interval, in seconds, that Oracle Retail Xenvironment will wait after a failed deployment download attempt before it tries to download the deployment again.

This setting is used by Oracle Retail Xenvironment at the store.
- **Detection Interval for Automatically Deployed Data Files**

How often (in minutes) the system checks the [Directory for Automatically Deployed Data Files](#) to be deployed automatically to all stores.
- **Directory for Automatically Deployed Data Files**

The directory into which DataLoader files can be placed for automatic deployment. DataLoader files placed in this directory will be automatically detected by Oracle Retail Xstore Office and will be deployed to the appropriate stores that are identified within the file.
- **Interval for Checking for Deployment Waves That Require Approval**

The time interval, in minutes, for running the Wave Approval email service. The default value is 60 minutes. For example, if set to 60 minutes, the service will run every hour to scan for new waves and send emails. An email will be sent for waves that meet the [Number of Days Before Deployment Wave to Send Notification](#) requirement.
- **Number of Days Before Deployment Wave to Send Notification**

The number of days prior to the projected launch date of a wave with a launch type of Approval Required that an email notification goes out. Valid values are from 1 to 365. The default value is 3 days.
- **Number of Records in Deployment Viewer**

The maximum number of Deployment records to display per page in the Deployment Viewer.

## General Category

- **Beginning Time of the Business Day**

To support alert reporting, this is the time-in hours from 00:00 UTC, that denotes the corporate start time of the business day. (For example, 5 is 05:00 UTC.)
- **Default Country Code**

The default country code for use in Xadmin.

- **Default Currency Code**

The default currency code for use in Xadmin. All monetary values entered and displayed across Xadmin are assumed to be of the default currency.

- **Default Deposit Bank Account Number**

When creating a new store, this is the default deposit bank account number.

- **Default Deposit Bank Name**

When creating a new store, this is the default deposit bank name.

- **Default Locale Code**

The default locale code (language) used in Xadmin for automated and system functions. The list of available locales includes all those which are officially part of Xadmin and are included in the list of the available locales for the organization.

- **Delete FIFO data after report generation?**

When enabled (true), FIFO data is deleted after a FIFO report is generated.

- **Enable the Option to Create Store-Specific Configurations?**

When enabled (true), users have the ability to create or override configurations for a specific store in Configurator. See [Configurator](#), section [Managing Configurations](#).

- **Enable the Option to Delete Configurations?**

When enabled (true), configurations for profile or store-specific overrides can be deleted in Configurator. If set to false, all access to this functionality is disabled within Oracle Retail Xstore Office, regardless of the privileges.

- **File Upload Directory**

The directory in which files are stored that are uploaded by users via the File Upload feature.

- **Interval for Checking for Missing Registers**

How frequently Xcenter checks for missing registers, in minutes. The default value is 15 minutes. The value of this setting should be less than the Time Before Register Is Considered Missing setting.

- **Number of Records in POSLog Publisher Result Page**

The maximum number of POSLog records displayed per page on the POSLog publisher result page. The minimum value allowed is 1.

- **POSLog Publish Max Search Results**

The maximum number of POSLog records returned from the database for republishing.

- **Published POSLog Directory**

The directory where the published PosLog file will be saved.

- **Time Before Missing Register Is Ignored**

Once a device has been missing for the amount of time specified here (in hours), it is no longer reported as a problem. The default value is 72 hours.

- **Time Before Register Is Considered Missing**

The amount of time-in minutes- that must elapse since a register's last check-in before it is considered missing. The default value is 61 minutes.

- **Use Till Based Accountability?**

When creating a new store, this option determines whether Till Accountability mode or Register Accountability mode is used as the default setting.

## Omni Channel Data Service



### Note:

The Omni Channel Data Service settings were moved to the xcenter.properties file.

## Purge

- **Enable Data Purge?**

Enable to purge old data and files per the additional settings in this category.

- **Data Purge Execution Time**

The time of day to start the automatic purge of data. Sets UTC time at which the job will occur. Enter this value in HH:MM format.

- **Number of Days to Keep Transactions**

The age in days that all transaction data (including line items, tenders, and so on), Order Broker order data, and inventory control documents that are part of end of year processing is kept in the Xcenter database when the purge process runs.

The number of days specified here should be greater than the number of days to keep customers and customer accounts.

This setting does not affect data kept in stores. If set to 0 all of this data is deleted. If set to -1 the data is kept indefinitely.

The purge setting for transactions must not be more aggressive than the possible period for customer accounts like layaways and special orders to be completed. If one of the transactions related to a customer account is purged before the customer account is closed AND the in-store database is replaced (for example, as part of a hardware refresh) the customer account will not be serviceable. Specifically, the items on the account cannot be picked up, nor can the payments be refunded.

- **Number of Days to Keep POSLogs**

The age in days that all POSLog data is kept in the Xcenter database when the purge process runs. This setting does not affect data kept in stores. If set to 0 all of this data is deleted. If set to -1 the data is kept indefinitely.

- **Number of Days to Keep Customers and Customer Accounts**

The age in days that all identifying customer data, loyalty data, and customer relationship data is kept in the Xcenter database when the purge process runs. This setting does not affect data kept in stores. If set to 0 all of this data is deleted. If set to -1 the data is kept indefinitely.

- **Number of Days to Keep Event Logs**



The age in days that all sourcing and targeting information for application updates to be delivered to/installed on clients is kept in the Xcenter database when the purge process runs. This setting does not affect data kept in stores. If set to 0 all of this data is deleted. If set to -1 the data is kept indefinitely.

- **Number of Days to Keep Cycle Questions**

The age in days that location data involving open/close process questions and answers, business date, workstation status, and retail location status are kept in the Xcenter database when the purge process runs. This setting does not affect data kept in stores. If set to 0 all of this data is deleted. If set to -1 the data is kept indefinitely.

- **Number of Days to Keep Discounts and Deals**

The age in days that discount and deal data, including concurrent discount compatibility data, customer group discount mapping data, item exclusion/inclusion data, eligibility data, deal definition data, customer group deal mapping data, item-based deal rules, matching rules, deal triggers, and time-based deal rules is kept in the Xcenter database when the purge process runs. This setting does not affect data kept in stores. If set to 0 all of this data is deleted. If set to -1 the data is kept indefinitely.

- **Number of Days to Keep Email**

The age in days that all emails associated with transactions is kept in the Xcenter database when the purge process runs. This purge setting does not affect data kept in stores. If set to 0 all of this data is deleted. If set to -1 the data is kept indefinitely.

- **Number of Days to Keep Employee Hours and Payroll**

The age in days that all employee data in the Xcenter database concerning employment dates, pay, vacation, tasks, schedule, and timeclock entries is kept in the Xcenter database when the purge process runs. This setting does not affect data kept in stores. If set to 0 all of this data is deleted. If set to -1 the data is kept indefinitely.

- **Number of Days to Keep Inventory**

The age in days that all inventory data in the Xcenter database concerning inventory buckets, cartons, counts, count sheets, and count snapshots is kept in the Xcenter database when the purge process runs. This setting does not affect data kept in stores. If set to 0 all of this data is deleted. If set to -1 the data is kept indefinitely.

- **Number of Days to Keep Invoices and Documents**

The age in days that all invoice and document data, including country pack related invoices and documents, is kept in the Xcenter database when the purge process runs. This setting does not affect data kept in stores. If set to 0 all of this data is deleted. If set to -1 the data is kept indefinitely.

- **Number of Days to Keep Items**

The age in days that all item data in the Xcenter database such as attached items, item messages, prices, deal properties, restrictions, refund schedule, and warranty information is kept in the Xcenter database when the purge process runs. This purge setting does not affect data kept in stores. If set to 0 all of this data is deleted. If set to -1 the data is kept indefinitely.

- **Number of Days to Keep Orders**

The age in days that all cancelled and completed order data, including customer data associated with the order, fulfillment details, sourcing details, payment information, and balance data is kept in the Xcenter database when the purge process runs. This purge setting does not affect data kept in stores. If set to 0 all of this data is deleted. If set to -1 the data is kept indefinitely.

- **Number of Days to Keep Report and Receipt Output**

The age in days that all report data, including country pack related, and common data such as receipt text, work order service locations, vendor addresses, airport zones, and reason codes is kept in the Xcenter database when the purge process runs. This purge setting does not affect data kept in stores. If set to 0 all of this data is deleted. If set to -1 the data is kept indefinitely.

- **Number of Days to Keep Tax**

The age in days that all tax data in the Xcenter database including exemptions, rules, and rule overrides is kept in the Xcenter database, when the purge process runs. This purge setting does not affect data kept in stores. If set to 0 all of this data is deleted. If set to -1 the data is kept indefinitely.

- **Number of Days to Keep Tender, Voucher and Session Info**

The age in days that all tender, voucher, and session data from the Xcenter database including denominations, availability, user settings, and options is kept in the Xcenter database when the purge process runs. This purge setting does not affect data, kept in stores. If set to 0 all of this data is deleted. If set to -1 the data is kept indefinitely.

- **Number of Days to Keep Flight Info**

The age in days that all flight data is kept in the Xcenter database when the purge process runs. This purge setting does not affect data kept in stores. If set to 0 all of this data is deleted. If set to -1 the data is kept indefinitely.

- **Number of Days to Keep Completed Deployments**

The age in days that completed or canceled deployment files, transferred to the file server, will be kept when the purge process runs. If set to 0 all of these files are deleted. If set to -1 the files are kept indefinitely.

- **Number of Days to Keep File Transfer Archives**

The age in days that archive folders from the AutoFileTransferDirectory will be kept when the purge process runs. If set to 0 all of these files are deleted. If set to -1 the files are kept indefinitely.

- **Number of Days to Keep File Uploads**

The age in days that files uploaded via Xadmin will be kept when the purge process runs. If set to 0 all of these files are deleted. If set to -1 the files are kept indefinitely.

- **Number of Days to Keep POSPoll Files**

The age in days that old files from Xcenter's POSPoll File Directory will be kept when the purge process runs. If set to 0 all of these files are deleted. If set to -1 the files are kept indefinitely.

- **Number of Days to Keep Republished POSLogs**

The age in days that old POSLogs from the POSLog Publisher Remote File Directory will be kept when the purge process runs. If set to 0 all of these files are deleted. If set to -1 the files are kept indefinitely.

- **Number of Days to Keep Temporary Store Requests**

The age in days that all temporary store request data is kept in the Xcenter database when the purge process runs. This purge setting does not affect data kept in stores. If set to 0 all of this data will be deleted. If set to -1 files are kept indefinitely.

## Temporary Store Server Management

- **Temporary Store Employee Message Duration**

Duration (in days) employee message must be on when status of temporary store request changes.

## Reports Category

- **Default Report Output Format.**

The report output format to be used as the default type when running reports. Valid values include:

- PDF (Portable Document Format)
- HTML (Hyper Text Markup Language)
- XLS (Spreadsheet file format created by Microsoft for use with MS Excel)
- XLSX (MS Excel 2007 or newer)
- PPTX (MS PowerPoint)
- RTF (Rich Text Format)
- DOCX (Microsoft Office Open XML Format Document)

- **Enable DOCX (MS Word) as a Report Output Format?**

If true, reports can be produced in DOCX format.

- **Enable HTML (Hyper Text Markup Language) as a Report Output Format?**

If true, reports can be produced in HTML format.

- **Enable PDF (Portable Document Format) as a Report Output Format?**

If true, reports can be produced in PDF format.

- **Enable PPTX (MS PowerPoint) as a Report Output Format?**

If true, reports can be produced in PPTX format.

- **Enable RTF (Rich Text Format) as a Report Output Format?**

If true, reports can be produced in RTF format.

- **Enable XLS (MS Excel) as a Report Output Format?**

If true, reports can be produced in XLS format.

- **Enable XLSX (MS Excel 2007 or Newer) as a Report Output Format?**

If true, reports can be produced in XLSX format.

## User Account Category

- **Default Domain Name for LDAP.**

The default domain name to be used when authenticating users using LDAP.

- **Enable LDAP Authentication Option?**

If set to Yes, enables Oracle Retail Xstore Office to authenticate users using LDAP directory. This is the global on/off switch.

- **LDAP Provider URL.**

The URL to be used to connect to the LDAP server.

- **Method of Creating Password for New Users.**

The method used to create the password for newly added users. See [Password Options - Non LDAP](#) for more information about the three options available.

- **Number of Capital Letters Required for a Password.**

The minimum number of capital letters that should appear in a password. The default value is 1. The minimum number is zero (0).

- **Number of Changes Before a Password Can Be Reused.**

The number of password resets within which associates are not allowed to reuse the same password. For example, setting the value to 12 ensures a user's new password cannot match any of his/her 12 previous passwords. A setting of zero (0) means that the same password can always be reused.

- **Number of Consecutive Characters Allowed in a Password.**

The maximum number of times that any given symbol or character can repeat consecutively within the password string. The default value is 2.

- **Number of Login Attempts Before Account Is Locked.**

The number of times an invalid password can be entered before the Oracle Retail Xstore Office user account is locked.

- **Number of Numbers Required for a Password.**

The minimum number of digits that should appear in a password (accepted values = 0-9). The minimum number is zero (0). The default value is 1.

- **Number of Special Characters Required for a Password.**

The minimum number of special characters that should appear in a password. The default value is 1 special character. See [Passwords: Special Characters & Rules](#) for a list of valid special characters.

- **Password Expiration Days.**

The number of days that a password can be used before it expires. The default value is 90 days.

- **Password Length.**

The minimum length of a password. The default value is 8.

 **Note:**

If this value is set to less than 1, passwords have no minimum length, but cannot be empty/blank.

- **User ID Length.**

The minimum number of characters in an Oracle Retail Xstore Office user ID. Valid values are 1 through 30.

## Customization Management

The Customization Management page allows you to make customizations, for example, to the Xadmin menu structure, or the Xcenter data model.

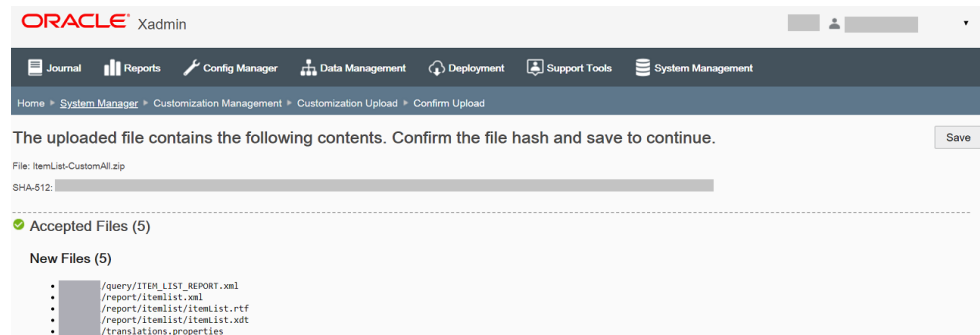
1. From the Oracle Retail Xstore Office menu, select **System Management** then **System Manager**, and **Customizations** or click the **System Manager** link in the System panel, and then select **Customizations**.
2. The Customization Management page displays, showing a list of uploaded configuration files.

## Uploading Configuration Files

To upload a configuration file:

1. Click **Upload New**. The window appears.
2. Click **Choose File**.
3. Select a file and click **OK**.
4. Click **Upload** to upload the selected file.
5. The system displays the Confirm Upload page.

**Figure 3-2**



The Confirm Upload page shows the following sections:

- **SHA Signature**  
The SHA signature is a hash of the file that was uploaded so the user can confirm that the server received what the user uploaded.
- **Failed Validations**  
This section shows files with validation errors. The total number of failed files, the file name and a short description of the error are displayed. The files must be updated and re-uploaded to be accepted.
- **Accepted Files**

This section shows the accepted uploaded files. The total number of accepted files, the file name, along with the information that this file will replace the existing one, are displayed.

- **Unchanged Files**

This section identifies unchanged files. The system will recognize the file contents as unchanged and do not need to be uploaded again, and therefore will bypass them during the upload process.

- **Unacceptable Files**

This section shows files containing an unsupported file type or location. The total number of unacceptable files and the file name are displayed.

6. Click **Save**.
7. You are prompted to confirm the upload. Click **Yes**.
8. The system saves the configurations to the database. On the Customization Management page the accepted files are listed.

**Figure 3-3 Customization Management**

Type	Customization	Last Update	Last Update User
Action Configuration	ActionConfig.xml	Dec 20, 2018, 9:43:39 AM	gerinde.rust@oracle.com
Menu Configuration	MenuConfig.xml	Dec 20, 2018, 9:43:39 AM	gerinde.rust@oracle.com
System Configuration	SysConfig.xml	Dec 20, 2018, 9:43:39 AM	gerinde.rust@oracle.com
System Configuration Metadata	SystemConfigMetadata.properties	Dec 20, 2018, 9:43:39 AM	gerinde.rust@oracle.com
Translations	translations.properties	Dec 20, 2018, 9:43:39 AM	gerinde.rust@oracle.com

## Exporting Active Configuration Files from the Configuration List

To export all active configuration files:



**Note:**

You can only export all active customizations, if you hold the required security privilege. If you do not hold the required privilege the Export button is disabled.

1. On the Customization Management page, select Export.
2. All active customizations are downloaded in a zip file through the browser.

## Deleting Configuration Files from the Configuration List

To delete a configuration file:

1. Select the Delete icon next to the file.

 **Note:**

Only properties files can be deleted from the list of configurations.

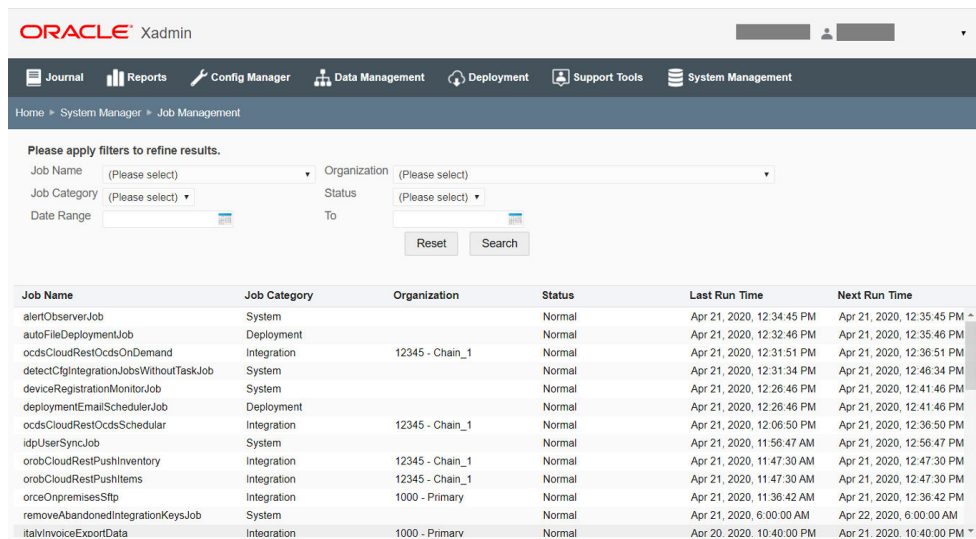
- When prompted, click **Yes** to confirm the deletion. The file is deleted from the list.

## Job Management

The Job Management screen enables you to view scheduled quartz jobs and their status.

- From the Oracle Retail Xstore Office Cloud Service menu, select **System Management**, then **System Manager**, and **Jobs** or click the **System Manager** link in the **System** panel, and then select **Jobs**.
- The Job Management page is displayed, detailing jobs currently scheduled. The jobs displayed in the Job Summary table are only for the organizations the user has access to. By default the jobs are sorted by last run time. If the last run time is null for both comparing jobs, then the jobs are sorted by job name.

**Figure 3-4 Job Management**



Job Name	Job Category	Organization	Status	Last Run Time	Next Run Time
alertObserverJob	System		Normal	Apr 21, 2020, 12:34:45 PM	Apr 21, 2020, 12:35:45 PM
autoFileDeploymentJob	Deployment		Normal	Apr 21, 2020, 12:32:46 PM	Apr 21, 2020, 12:35:46 PM
ocdsCloudRestOcdsOnDemand	Integration	12345 - Chain_1	Normal	Apr 21, 2020, 12:31:51 PM	Apr 21, 2020, 12:36:51 PM
detectCgIntegrationJobsWithoutTaskJob	System		Normal	Apr 21, 2020, 12:31:34 PM	Apr 21, 2020, 12:46:34 PM
deviceRegistrationMonitorJob	System		Normal	Apr 21, 2020, 12:26:46 PM	Apr 21, 2020, 12:41:46 PM
deploymentEmailSchedulerJob	Deployment		Normal	Apr 21, 2020, 12:26:46 PM	Apr 21, 2020, 12:41:46 PM
ocdsCloudRestOcdsScheduler	Integration	12345 - Chain_1	Normal	Apr 21, 2020, 12:06:50 PM	Apr 21, 2020, 12:36:50 PM
idpUserSyncJob	System		Normal	Apr 21, 2020, 11:56:47 AM	Apr 21, 2020, 12:56:47 PM
orobCloudRestPushInventory	Integration	12345 - Chain_1	Normal	Apr 21, 2020, 11:47:30 AM	Apr 21, 2020, 12:47:30 PM
orobCloudRestPushItems	Integration	12345 - Chain_1	Normal	Apr 21, 2020, 11:47:30 AM	Apr 21, 2020, 12:47:30 PM
orceOnpremiseSftp	Integration	1000 - Primary	Normal	Apr 21, 2020, 11:36:42 AM	Apr 21, 2020, 12:36:42 PM
removeAbandonedIntegrationKeysJob	System		Normal	Apr 21, 2020, 6:00:00 AM	Apr 22, 2020, 6:00:00 AM
itaInvoiceExportData	Integration	1000 - Primary	Normal	Apr 20, 2020, 10:40:00 PM	Apr 21, 2020, 10:40:00 PM

- You can filter the jobs by:
  - Job Name**  
The Job Name column displays the defined job description for the scheduled job.
  - Job Category**  
This column displays the job category.
  - Organization**  
The organization column displays the organization ID and organization name in which the job is impacting.

Only jobs for the organization(s) the user has access to are displayed, all other jobs are hidden.

If the job spans across the entire implementation, this field is left blank.

- **Status**

This column displays the status of the job. Possible statuses include:

None

Normal

Complete

Paused

Error

Blocked

- **Last Run Time**

This column displays the UTC date-time stamp of the last run time of the job.

- **Next Run**

This column displays the UTC date-time stamp of the next run time of the job.

4. Select **Search**. The data that matches the filter criteria is displayed in the table.

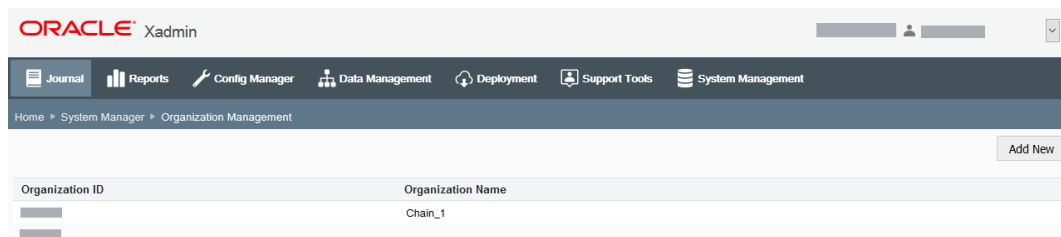
Select **Reset** to reset the filter criteria and update the search result in the table with the latest data.

## Organization Management

The Organization Management screen enables you to create an organization without restarting the application.

1. From the Oracle Retail Xstore Office Cloud Service menu, select **System Management**, then **System Manager**, and **Organizations** or click the **System Manager** link in the **System** panel, and then select **Organizations**.
2. The Organization Management page displays, showing a list of organizations.

**Figure 3-5 Organization Management**



## Adding an Organization

1. To add an organization, select **Add New**.



2. The Organization Details window is displayed.
3. In the Organization ID field, enter the organization ID.
4. In the Organization Name field, enter the organization name.
5. Select **Save**, to save your entries.

## Editing an Organization

To edit an existing organization:

1. On the Organization Management page, select an organization.
2. Click on the organization, the Edit Organization window is displayed.
3. Update the Organization Name.

 **Note:**

When editing an organization, the organization ID cannot be changed.

- Select **Save** to save your updates.
- Select **Previous or Next** to update previous/next organizations.

 **Note:**

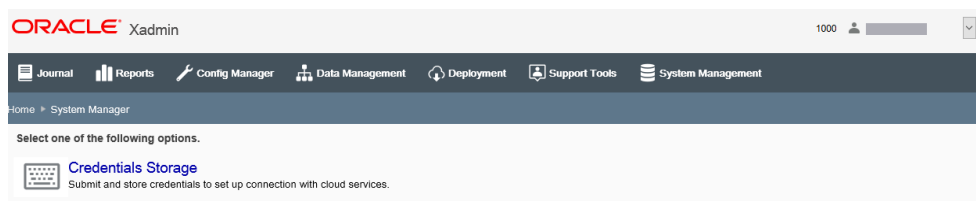
The **Next** and **Previous** options are only available if more than one organization has been defined.

## System Manager

The System Manager menu allows you to manage system management options.

1. From the Oracle Retail Xstore Office menu, select **System Management**, then select **System Manager**.
2. The System Manager menu displays. The following options are available:
  - [Credentials Storage](#)

**Figure 3-6 System Manager**



## Credentials Storage

Use this function to submit and store credentials to set up a connection with cloud services. These credentials will allow Xstore Office On-Premise to communicate with Identity Cloud Service (IDCS).

To store and set up the communication with cloud services, follow the steps below.

1. At the Credentials Storage page, enter the **Client ID**.
2. Then enter the **Client Secret**.
3. Press **Save**. The system validates the credentials. If the validation is successful a message is displayed. Then system regenerates the client secret.
  - If the regeneration was successful, the system saves the client ID and secret to the database.
  - If the regeneration was not successful, a message is displayed.

### Note:

This function is only available if you have sufficient security privilege. See [Appendix: Enrollment with Cloud Services](#) on how to Enroll Xstore Office On-Premise to communicate with Cloud Service applications.

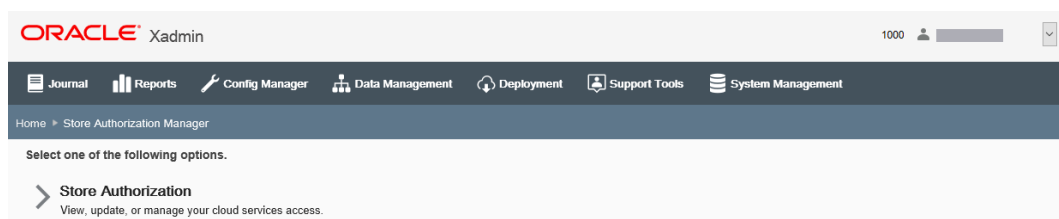
Additionally see the Oracle Retail Omnichannel Web Service Authentication Configuration Guide (Doc ID 2728265.1) on My Oracle Support, for more information about how to configure web service authentication for the Retail Omnichannel products.

## Store Authorization Manager

The Store Authorization Manager screen allows you to access all store related functions from the same menu.

1. From the Oracle Retail Xstore Office menu, select **System Management**, then select **Store Authorization Manager**. The Store Authorization Manager screen displays. You have the following option:
  - Store Authorization Manager

**Figure 3-7 Store Authorization Manager Page**



2. Select **Store Authorization Manager**.

3. Then select an organization node and press **Next**.
4. You have the following option:
  - [Store Enrollment](#)

## Store Enrollment

Use this functionality to register and redirect all stores in the selected organization to your Xstore Office Cloud environment. The Store enrollment functionality offers two options:

- Enroll all stores in the selected organization node with Xstore Office On-Premise to communicate with Cloud Service applications, like Customer Engagement, through Identity Cloud Service (IDCS).

 **Note:**

This function is only available if configured and if you have sufficient security privilege. Xstore Office OnPrem OAuth Client must be generated to enroll stores. See [Appendix: Enrollment with Cloud Services](#) on how to Enroll Xstore Office On-Premise to communicate with Cloud Service applications and how to enroll Xstore Stores in Xstore Office Cloud Service through the Xstore Office UI (On-Premise).

Additionally see the *Oracle Retail Omnichannel Web Service Authentication Configuration Guide* (Doc ID 272825.1) on My Oracle Support, for more information about how to configure web service authentication for the Retail Omnichannel products.

- Enroll all stores in the selected organization node through Xstore Office Cloud Service to communicate with the Cloud Services applications through Identity Cloud Service (IDCS).

 **Note:**

This function is only available if configured and if you have sufficient security privileges. You also need a separate Xstore Office Cloud instance running to migrate your stores to Cloud.

Figure 3-8 Store Enrollment

At the Store Enrollment screen you have two options:

- Enroll all stores in the organization node with cloud services.
  - Select **Enroll**. No connection details are required.

A deployment will be created for each location in the selected organization node to be applied during the next store close.

At the next store close, all POS applications will be configured for IDCS service. All systems will be restarted.
- Enroll all stores in the organization node with an Xstore Office Cloud Service environment.
 

Collect the following data prior to starting the Xoffice Cloud Enroll process.

  - Xstore Office Cloud Hostname and Port. The Customer Administrator can look this up by logging into their Cloud Service Account.
  - IDCS User credentials: Username and Password of any IDCS user belonging to the provisioned IDCS tenant.

Enter the connection details for the Xcenter cloud Xstore Office Cloud URL.

  - Username: Username of an IDCS user (This is typically an email address)
  - Password: Password of an IDCS user
  - Host: Xstore Office Cloud Hostname
  - Port: Xstore Office Cloud Port
  - Provisioning ID: Customer's Provisioning ID
  - Tenancy ID: References the prod, stage or dev environment. It will be of the format `rgbu-omni-<cust>-<env><num>-xocs` and is part of the application url.

 **Note:**

The Tenancy ID filed will only be available with Xstore Office 20.0.1 and environments above.

Then click **Enroll with Xoffice Cloud** to validate credentials and enroll the location(s). A deployment will be created for each location in the selected organization node to be applied during the next store close.

At the next store close, all POS applications will be configured for Xstore Office Cloud service. All systems will be restarted.

## Available Locales

### Note:

This feature is only available from the Oracle Retail Xstore Office System menu, not from the Home Page panel.

This feature controls the available locales within the Oracle Retail Xstore Office application itself.

1. From the Oracle Retail Xstore Office menu, select **System Management**, then select **Available Locales**.
2. The Available Locales page displays. Add a new locale, make changes to an existing locale, or delete a locale:

**Figure 3-9 Available Locales Page**

Locale	Description	Display Order	
en_US	US English	10	X
en_AU	English (Australia)	100	X

- To add a new locale, click the **Add New** button.
- To make changes to an existing locale, click on an existing locale from the list.
- To delete a locale, click the **Delete** icon associated with the locale. If selected, you will be prompted to confirm the locale should be deleted. Any locale currently assigned to a user record cannot be deleted.

### Note:

A sorting component is available for columns, when applicable.

3. Complete the fields as required when adding or editing a locale:
  - Locale - Select a locale from the drop-down list. The locale cannot be changed in edit mode.

- Display Order - Enter the display order for the locale.
4. Click the **Save** button.

## Where Locale Is Used

If more than one available locale has been defined in Oracle Retail Xstore Office, certain fields in Configuration Manager and Data Management will allow the user to enter a translation for any language. This action creates `com_translations` records that will be sent down to stores, along with the configuration data.

# 4

## Profile Management

The goal of the Profile Management component of Configuration Manager is to define Store Personalities for your organization. The Store Personalities allow you to easily maintain portions of your configuration paths using a GUI format in Oracle Retail Xstore Office. Behind the scenes, these Store Personalities are translated into the various configuration paths specified in `configPath.properties`. For more information on Personality Maintenance and configuration paths, see [Appendix: Personality Maintenance and Config Paths](#)

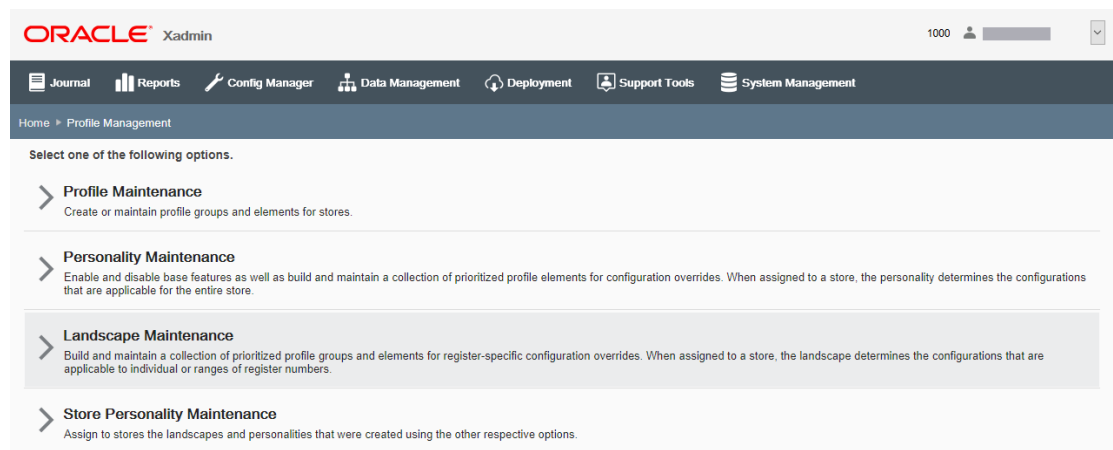
### Note:

The Configurator component of Configuration Manager is used to create, maintain, and deploy Oracle Retail Xstore Point-of-Service configuration changes selectively, or globally across the entire organization. Refer to [Configurator](#) for more information about making configuration changes and deploying the information to your stores.

## About this Chapter

Profile Management includes functions for creating and maintaining profile groups and elements for stores and registers, creating and maintaining the personalities that determine the prioritized profile elements for configuration overrides, and creating and maintaining the store landscapes used for machine (register) configurations. After setting up this information, you can assign Store Personalities to your stores.

**Figure 4-1 Profile Management Page**



## Setup Overview

1. First, create Profile Groups and their associated Elements. Follow the steps outlined in [Profile Maintenance](#) to set up and maintain the Profile Groups.
2. Next, after creating the Profile Group and Element combinations, set up your Personalities and Landscapes.
  - A Personality is a grouping of at least one or many Profile Group and Element combinations in an ordered list that work together to define a store. For example, using the Profile Groups and Elements you set up previously (step 1 above), you can identify a personality as being Canadian, Banner, Outlet, in addition to another personality defined as US, Banner, Flagship, Retail, and so on.
  - A Landscape is a collection of prioritized profile groups and elements for register-specific configuration overrides. When assigned to a store, the landscape determines the configurations that are applicable to individual register numbers or ranges of register numbers (for example, "22-Managers Terminal", "44-Lead Register", and so on).

Follow the steps outlined in [Personality Maintenance](#) and [Landscape Maintenance](#) to create Personalities and Landscapes.
3. Finally, set up each Store Personality by assigning the Personalities and Landscapes you created (step 2 above) to your stores. Follow the steps outlined in [Store Personality Maintenance](#) to create Store Personalities.

## Summary

- The Profile Groups/Elements you create (step 1) will be used to set up Personalities and Landscapes.
- The Personality/Landscape pairs (step 2) will then be used to create a Store Personality (step 3).

## Profile Maintenance

This section describes the profile maintenance functionality.

### Setting Up Profile Groups & Elements

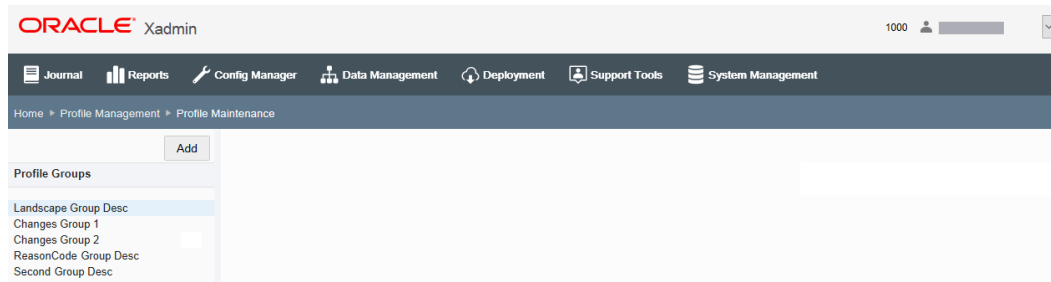
The profiles you set up here will be available as configuration scope overrides for Personality and Landscape group types in the Configurator component, providing the ability to deploy configurations that will override the global layer for specific locations as defined by the Store Personality. Refer to [Configurator](#) for more information about the Configurator component.

Profile Groups are used to associate configuration overrides with specific Profile Elements.

- A Profile Group is simply a collection of configuration elements by type; for example Location, Register Type, Store Type, and so on.
- A Profile Element is the child property associated with the Profile Group; for example, Location= Ohio, California, Iowa, and so on.



1. From the Oracle Retail Xstore Office menu, select **Configuration Manager**, then **Profile Management**, or click the Profile Management link in the Configuration Manager panel.
2. From the Profile Management page (Figure 4-1), select **Profile Maintenance**.
3. The Profile Maintenance page displays. Click **Add** to create a new Profile Group.

**Figure 4-2 Profile Maintenance Page**

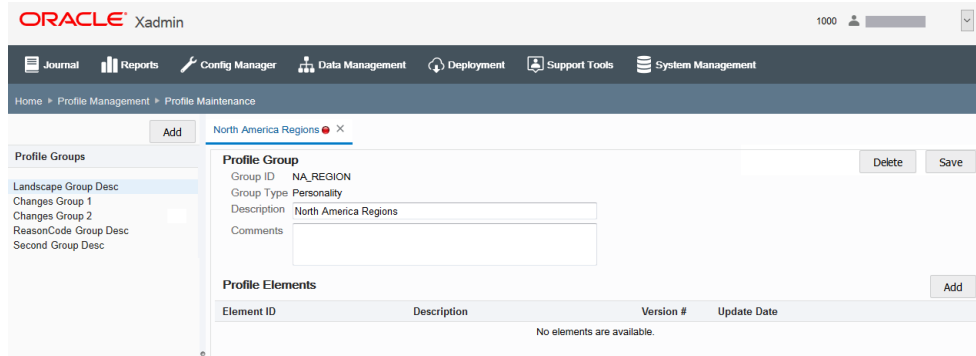
4. At the Create Profile Group window, enter the information required to create a new Profile Group:


**Figure 4-3 Create Profile Group Window**

- a. Group ID - The profile group identifier. Spaces are not allowed here.
  - b. Group Type - The type of profile group: Personality or Landscape  
The Group Type selected here determines where the Profile Group will be available for selection when setting up Personalities and Landscapes. Landscape profile groups will only be available for Menu Configuration and System Configuration overrides.
  - c. Description - The profile group description.
  - d. Comments - [OPTIONAL] A comment associated with the Profile Group.
5. Click **OK**.

- The Profile Maintenance window displays the new Profile Group information you added.

**Figure 4-4 Profile Maintenance Window - Populated**



- The red icon  in the tab header indicates this Profile Group has not been saved.
  - To close the tab, click the close icon. You will be prompted if there are unsaved changes.
  - To delete this Profile Group, click **Delete**. You will be prompted to confirm the deletion.
  - If a Profile Group (and its Elements) is being used by a Personality or Landscape, it cannot be deleted.
- Click **Save** to save the Profile Group to the Profile Group list, or continue with step 8 below before saving.
  - Click **Add** in the Profile Elements section of the window to add elements to this Profile Group.
  - At the Create Profile Element window, enter the information required to create a new Profile Element for the Profile Group:

**Figure 4-5 Create Profile Element Window**



- a. Element ID - The element identifier. (Note: Spaces are not allowed here.)
  - b. Description - The element description.
  - c. Comments - [OPTIONAL] A comment associated with the Profile Element.
10. Click **OK**.
  11. Repeat steps 8 through 10 to add additional Elements to the Profile Group.
  12. When all Elements have been associated with the Profile Group, click **Save**.

**Figure 4-6 Profile Group and Elements - Before Saving Example**

The screenshot shows the Oracle Xadmin interface for Profile Maintenance. The main area displays a Profile Group named 'North America Region' with the following details:

- Group ID: NA\_Region
- Group Type: Personality
- Description: North America Regions
- Comments: (empty text area)

Below the group details is a table of Profile Elements:

Element ID	Description	Version #	Update Date	
EAST	East Region	1	Jul 18, 2018, 10:09:12 AM	✕
NORTH	North Region	1	Jul 18, 2018, 10:08:08 AM	✕
SOUTH	South Region	1	Jul 18, 2018, 10:08:36 AM	✕
WEST	West Region	1	Jul 18, 2018, 10:09:24 AM	✕

The Profile Group created here will now be available in the Overrides feature in the Personality Maintenance and Landscape Maintenance sections of Profile Maintenance where applicable for the group type. (See [Figure 4-1](#))

Delete Options:

- If you need to delete the Profile Group and all the associated Elements, click the **Delete** button.
- If you need to delete an Element, click the Delete icon.
- You will be prompted to confirm your selection.
- If a Profile Group (and its Elements) is being used by a Personality or Landscape, it cannot be deleted.

## Profile Group and Element Versioning

The version number is shown on the Profile Maintenance page for the Profile Group and Element. This value will be increased by one each time the Profile Group/ Element is deployed, or scheduled for deployment, with a new set of configurations.

## About Profile Group and Element Versioning

- The version number is not increased until the configuration is deployed (or scheduled for deployment). Editing an existing profile element does not increment the version number.
- Rollback is not available at this time.

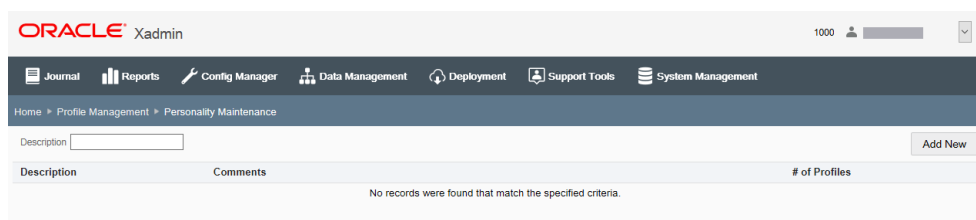
- Audit logging includes who, when, and in which version the change was made.
- See also [Configurator](#).

## Personality Maintenance

Use Personality Maintenance to group one or many Profile Group and Element combinations that will be used to define a store.

1. From the Oracle Retail Xstore Office menu, select **Config Manager - Profile Management**, or click the Profile Management link in the Configuration Manager panel.
2. From the Profile Management page ([Figure 4-1](#)), select **Personality Maintenance**.
3. At the Personality Maintenance page, add a new Personality or edit an existing one:

**Figure 4-7 Personality Maintenance Page**



### Note:

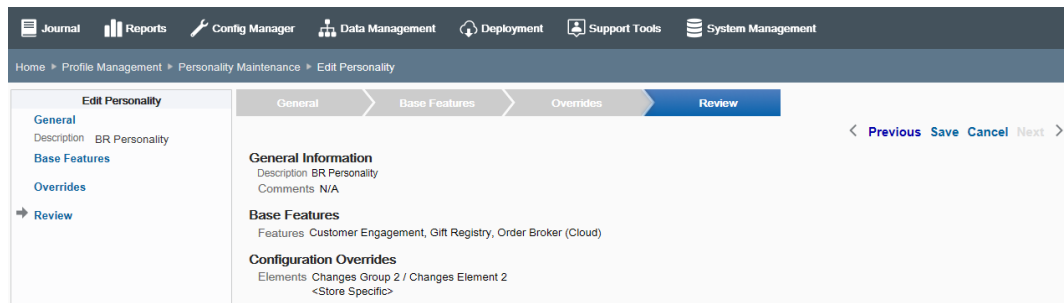
To quickly find a Personality, enter text in the Description field. The list will be filtered to show the Personalities with the text in their descriptions.

If adding a new Personality:

- a. Click **Add New**.
- b. At the Edit Personality page, use the wizard to complete the information on each tab, then click **Next**. See [Personality Setup Options](#) for a list of Personality options.
- c. Skip to step 4 to review your selections.

If editing an existing Personality:

- a. Select the Personality in the list.
  - b. At the Personality Detail window, click **Edit**.
  - c. Complete the fields as required, then click **Next**. See [Personality Setup Options](#) for a list of Personality options.
  - d. Continue with step 4 to review your selections.
4. Review the Personality options you selected:

**Figure 4-8 Personality Options Review**

- To save the Personality, click **Save**. The Personality is added to the list on the Personality Maintenance page.
  - To edit the Personality:
    - Click **Previous** to go back one page, or select a configuration option in the Edit Personality section in the left panel of the window.
    - After making your changes, click **Save**. The new Personality is added to the list on the Personality Maintenance page.
  - To discard the Personality, click **Cancel**. When prompted, click **Yes** to confirm you want to cancel Personality setup.
5. After completing Personality setup, Oracle Retail Xstore Office returns to the Personality Maintenance page.
- To delete a Personality that has been created or updated, click the Delete icon associated with the Personality on the Personality Maintenance page.
  - When prompted, click **Yes** to confirm the deletion.
  - If a Personality has been assigned to a Store, it cannot be deleted.

## Personality Setup Options

This section describes the personality setup options.

### General Information

Define the basic information for the Personality, then click **Next**.

1. Description - Enter the Personality identifier.
2. Comments - [OPTIONAL] Enter additional identifying information for the Personality.

### Base Features

Enable and disable the Oracle Retail Xstore Point-of-Service base features that are active for this Personality, then click **Next**.

For more information on the available base features, see the [xstore.config.path.base.features](#) section in [Appendix: Personality Maintenance and Config Paths](#).

## Overrides

About the Profile Group and Element combinations:

- The Profile Groups and Elements available here are created in Profile Maintenance. See [Profile Maintenance](#) for more information.
- Only the Profile Groups with the type "Personality" are available in the drop-down list. (Profile Groups with the type "Landscape" are not available in Personality Maintenance.)
- A <Store Specific> override entry is available by default in the drop-down list.

Select and prioritize the Profile Group and Element combinations:

1. Select the Profile Group for this Personality.
2. Select the Profile Element for this Personality.
3. Click **Add Element**.
4. Repeat steps a through c as needed to add all the Profile Group and Element combinations to this Personality.
5. If needed, select a Profile Group and Element combination row and use the up/down arrows to change the priority. Elements at the top of the list have higher priority.
6. If needed, click the icon to remove the Profile Group and Element combination from the Personality.
7. Click **Next**.

## Review

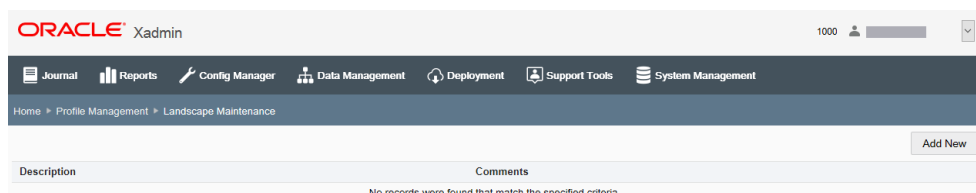
Review the options you selected. Go to step 4 on page 7.

## Landscape Maintenance

Use Landscape Maintenance to create and edit the register layout portion of configuration paths.

1. From the Oracle Retail Xstore Office menu, select **Config Manager - Profile Management**, or click the Profile Management link in the Configuration Manager panel.
2. From the Profile Management page ([Figure 4-1](#)), select **Landscape Maintenance**.
3. At the Landscape Maintenance page, add a new Landscape or edit an existing one.

**Figure 4-9 Landscape Maintenance Page**



- If adding a new Landscape, continue with [Adding a New Landscape](#) below.
- If editing an existing Landscape, skip to [Editing an Existing Landscape](#).

## Adding a New Landscape

1. At the Landscape Maintenance page, click **Add New**.
2. At the Edit Landscape page, complete the following information:

**Figure 4-10 Edit Landscape Page - Add New**

ORACLE Xadmin 1000

Journal Reports Config Manager Data Management Deployment Support Tools System Management

Home > Profile Management > Landscape Maintenance > Edit Landscape

Description  Save

Comments

The list below is used to add, remove, and control the priority of the profile groups for this landscape. Profile groups at the top of the list have higher priority. You may also click a row to edit the register ranges.

(Please select) Add New

Profile Group	Profile Element	Register Range
No records were found that match the specified criteria.		

- a. Description - Enter a short description for the new Landscape.
  - b. Comments - [OPTIONAL] Enter additional information about the new Landscape.
3. Select a Profile Group from the drop-down list, then click **Add New** to add the Profile Group to the Landscape.

### Note:

The Profile Groups and Elements available here are created in Profile Maintenance. See [Profile Maintenance](#) for more information. Only the Profile Groups with the type Landscape are available in the drop-down list. Profile Groups with the type Personality are not available in Landscape Maintenance.

4. At the Profile Group page, click **Add New** to add a Profile Element to the Profile Group.

**Figure 4-11 Profile Group Page - Register Types Example**

ORACLE Xadmin 1000

Journal Reports Config Manager Data Management Deployment Support Tools System Management

Home > Profile Management > Landscape Maintenance > Edit Landscape > Landscape Group Desc

Done Add New


Profile Element	Register Range
No records were found that match the specified criteria.	

5. At the Add Register Range window, complete the fields, then click **OK**.

**Figure 4-12 Add Register Range Window**

- a. Profile Element - Select a Profile Element from the drop-down list.
  - b. Register Range - Enter a starting and ending register range. If there is only one register, enter the register number in both fields.
6. Repeat steps 4 and 5 as needed to add all the Profile Elements and Register Ranges for the Profile Group.
  7. Click **Done** to return to the Edit Landscape page.
  8. You have the following options at the Edit Landscape page before saving the Landscape:

**Figure 4-13 Edit Landscape Page**

- To add additional Profile Groups and Elements to the Landscape, repeat steps 3 through 7.
- To edit the register ranges, select the row to open the Add Register Range window and make changes as needed.
- To change the priority, click the Selector Control icon  to select the row and activate the up and down arrows on the right side of the page.  
With the row selected, use the up/down arrows to move the row up or down in the list. Profile Groups at the top of the list have higher priority.
- To delete a register range, select the row and click the Delete icon.

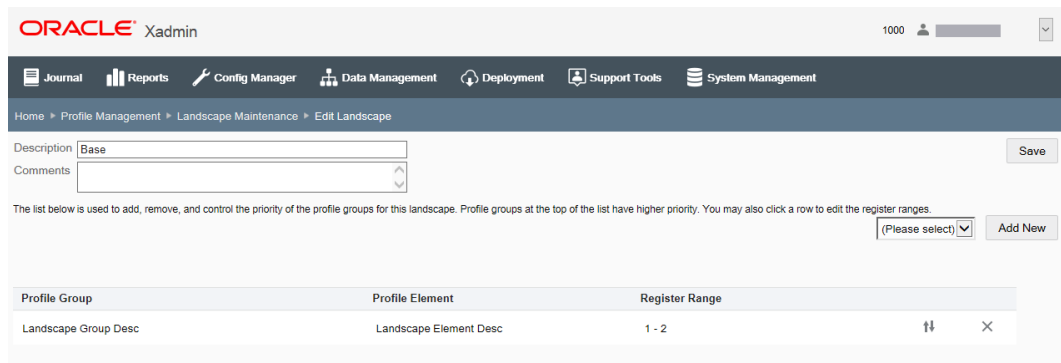


9. When Landscape setup is complete, click **Save** to return to the Landscape Maintenance page.


## Editing an Existing Landscape

1. At the Landscape Maintenance page, select the Landscape in the list.
  - To delete a Landscape, click the Delete icon.
  - When prompted, click **Yes** to confirm the deletion.
  - If a Landscape has been assigned to a Store, it cannot be deleted.
2. At the Edit Landscape page, edit the Landscape as needed:

**Figure 4-14 Edit Landscape Page**



- To change the Description or Comment, enter the information in the appropriate field.
- To add a new profile group perform step 3 on page 8 through step 7 on page 10.
- To edit the register ranges, select the row to open the Add Register Range window and make changes as needed.

- To change the priority, click the Selector Control icon  to select the row and activate the up and down arrows.
 

With the row selected, use the arrows to move the row up or down in the list. Profile Groups at the top of the list have higher priority.

3. Click **Save** when the edits are complete to return to the Landscape Maintenance page.

## Store Personality Maintenance

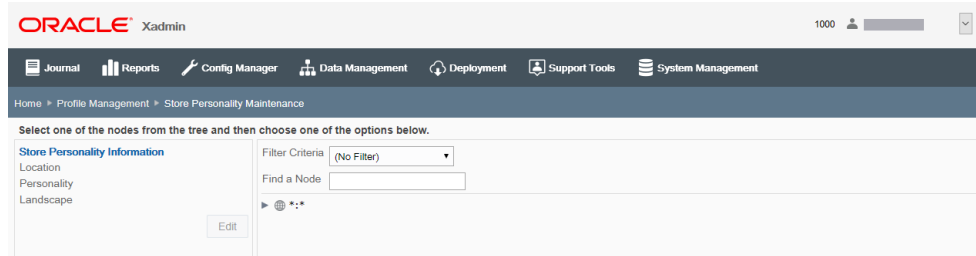
Store Personalities are used to create the configuration paths specified in configPath.properties.

Store Personality Maintenance is where you assign the Personalities (created in Personality Maintenance) and Landscapes (created in Landscape Maintenance) to stores.

1. From the Oracle Retail Xstore Office menu, select **Config Manager - Profile Management**, or click the Profile Management link in the Configuration Manager panel.
2. From the Profile Management page (Figure 4-1), select **Store Personality Maintenance**.

3. [OPTIONAL] At the Store Personality Maintenance page, use the Filter Criteria and Find a Node search options to quickly find a store:

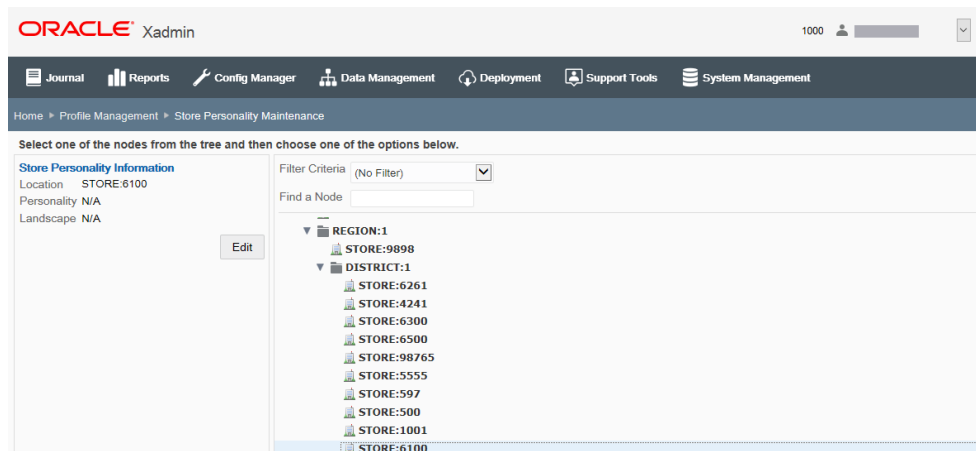
**Figure 4-15 Store Personality Maintenance Page**



To quickly find a store you can:

- Select an option from the Filter Criteria drop-down list to filter the nodes displayed in the org hierarchy tree based on assigned personalities and landscapes. The following filter options are available:
    - No Filter (default): Select this option to remove any filters.
    - No Store Personality - Select this option to display only the stores that do not have store personalities assigned to them.
    - Personalities or Landscapes: All the personalities created on the Personalities Maintenance page are listed under the heading Personalities, and all the landscapes created on the Landscapes Maintenance page are listed under the heading Landscapes. Select a personality or landscape to display only the stores that have the selected personality or landscape assigned to them.
- <OR>
- In the Find a Node field, begin typing the node description to search for a specific node in the org hierarchy tree.
4. From the hierarchy tree, select a node to assign a Personality/Landscape pair.

**Figure 4-16 Store Personality Maintenance Page - Store Node Selected**

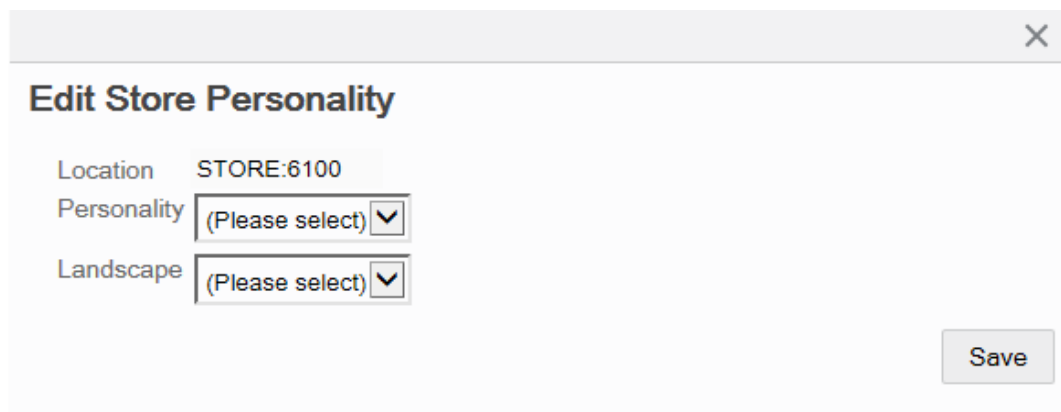


 **Note:**

If you select a non-store node (for example District), all stores contained in that node will be affected by any change made to the personality and landscape. This will remove and replace any personality/landscapes that were previously assigned to stores within that node.

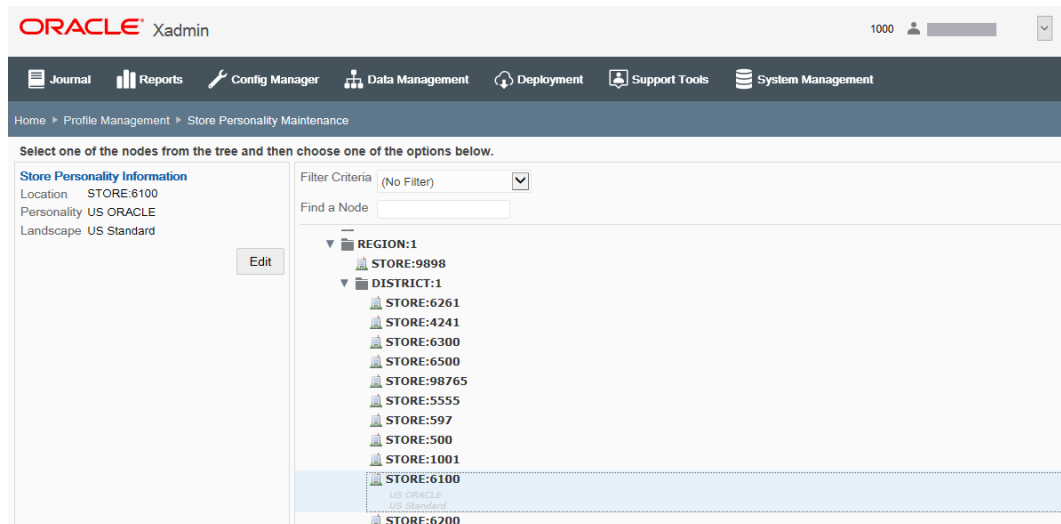
5. Click **Edit** to modify the personality/landscape assignments for the selected store.
6. At the Edit Store Personality window, select a Personality and a Landscape from the drop-down lists. Both a Personality and a Landscape are required.

**Figure 4-17 Edit Sore Personality Window**



7. Click **Save** to assign the selected Personality and Landscape to the store.

**Figure 4-18 Store Personality Maintenance Page - Assignment Complete**



See also [Appendix: Personality Maintenance and Config Paths](#).

# 5

## Configurator

The Configurator component of Configuration Manager is used to create, maintain, and deploy configuration changes selectively, or globally across the entire organization. See [About this Chapter](#) below for a list of the configuration areas described in this chapter.



### Note:

The Profile Management component of Configuration Manager is used to define "store personalities" in order to create configuration paths. Refer to [Profile Management](#) for more information about managing profiles and config paths.

The logged-in user is assumed to represent some tier of the organization. For this reason, the user's assigned org node hierarchy will determine the information he/she has access to. See [Roles, Users, and Security Access](#) for more information about users and security access.

## About this Chapter

The following areas can be configured in Configurator:

- Codes - Add, edit, and delete configurable codes. See [Configuring Codes](#).
- Discounts - Configure different types of discounts that may be manually applied during a sale transaction. See [Configuring Discounts](#).
- Reason Codes - Configure common reason codes. See [Configuring Reason Codes](#).
- Menu Configuration - Add, remove and edit options on Oracle Retail Xstore Point-of-Service menus and tabs. See [Configuring Menus and Tabs](#).
- Receipt Configuration - Configure common text, such as headers and footers, and change the logo for your sales receipts. See [Configuring Receipts](#).
- System Configuration - Configure behaviors/business rules for Oracle Retail Xstore Point of Service. See [Configuring Xstore Point-of-Service System Config Options](#).
- Security - Configure Oracle Retail Xstore Point-of-Service security groups and the privileges that are associated with those groups. This option applies to Global configurations only. See [Configuring Oracle Retail Xstore Point-of-Service Security](#).
- Tenders - Configure the settings and data related to tenders. See [Configuring Tenders](#).
- Customer Displays - Manage the text used on customer-facing displays. See [Configuring Customer Displays](#).

## Configuration Options and Availability Matrix

Configurator is used to create, maintain, and deploy Oracle Retail Xstore Point-of-Service configuration changes selectively, or globally across the entire organization. Not all

configuration options are available for all scopes. The following configuration scopes are available:

- Global Configurations - Change or deploy the global configuration layer which is the foundation for all locations.
- Configuration Overrides - Change or deploy configurations that will override the global layer for specific locations (Profile Groups).
- Store Specific Overrides - Change or deploy configurations that will override the global layer for specific stores.

**Table 5-1 Configuration Options**

Configuration Options	Scope Availability
Configure	<ul style="list-style-type: none"> <li>• Global Configurations</li> <li>• Configuration Overrides</li> <li>• Store Specific Overrides</li> </ul> <p><b>Note:</b> Store Specific Overrides scope is only available if Oracle Retail Xstore Office configuration "Enable the Option to Create Store-Specific Configurations?" is set to <b>Yes</b>.</p>
Deploy	<ul style="list-style-type: none"> <li>• Global Configurations</li> <li>• Configuration Overrides</li> <li>• Store Specific Overrides</li> </ul> <p><b>Note:</b> Store Specific Overrides scope is only available if Oracle Retail Xstore Office configuration "Enable the Option to Create Store-Specific Configurations?" is set to <b>Yes</b>.</p>
View Configuration Changes	<ul style="list-style-type: none"> <li>• Global Configurations</li> <li>• Configuration Overrides</li> <li>• Store Specific Overrides</li> </ul> <p><b>Note:</b> Store Specific Overrides scope is only available if Oracle Retail Xstore Office configuration "Enable the Option to Create Store-Specific Configurations?" is set to <b>Yes</b>.</p>
Delete Profile Configuration Changes	<ul style="list-style-type: none"> <li>• Configuration Overrides</li> <li>• Store Specific Overrides</li> </ul> <p><b>Note:</b> Delete Profile Configuration Changes option is only available if Oracle Retail Xstore Office configuration "Enable the Option to Delete Configurations?" is set to Yes</p>
Copy Store Configurations	<ul style="list-style-type: none"> <li>• Store Specific Overrides</li> </ul> <p><b>Note:</b> Store Specific Overrides scope is only available if Oracle Retail Xstore Office configuration "Enable the Option to Create Store-Specific Configurations?" is set to <b>Yes</b>.</p>

## Configuration Versioning

Oracle Retail Xstore Office creates and tracks version numbers for each set of configurations deployed via a profile group and element, globally, or a store specific group.

When you create a new configuration set, it is given a version number of 1 (one) to start. The next version number will be increased by one for that specific profile group to be used on the next set of configurations.

When a deployment is scheduled for a profile group and element, the `ProfileGroupId`, `ProfileElementId` and `ConfigVersion` are recorded in the manifest of the jar file that is produced. This manifest is then used by Oracle Retail Xstore Point of Service to log the version information.

When Oracle Retail Xstore Point of Service starts up, it reads the `ProfileGroupId`, `ProfileElementId` and `ConfigVersion` from the manifest of the jar file, and logs it in the `ctl_event_log` table with the following information:

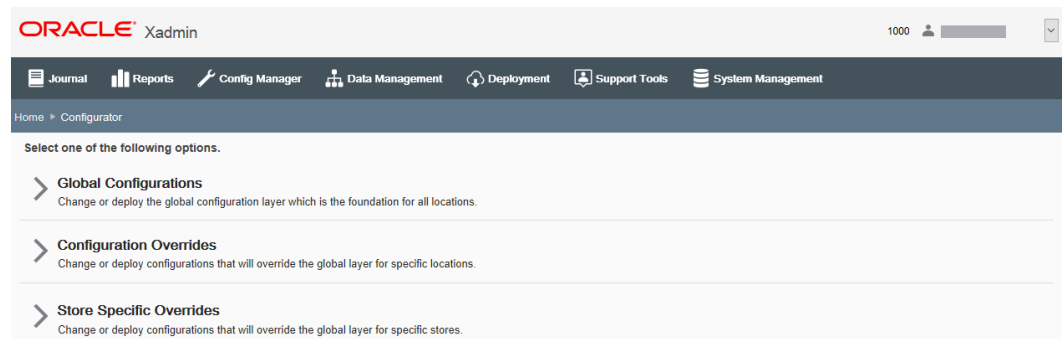
**Table 5-2** `ctl_event_log` Table

Column	Information logged
<code>logger_category</code>	<code>dtv.xstore.configversion</code>
<code>log_message</code>	<code>ProfileGroupId/ProfileElementId /ConfigVersion</code>

## Managing Configurations

1. From the Oracle Retail Xstore Office menu, select **Config Manager - Configurator**, or click the Configurator link in the Configuration Manager panel.
2. Select the Configuration Scope:

**Figure 5-1** Configuration Scope Options Page



- Select **Global Configurations** to change the global configuration layer which affects all locations. Continue with step 3 on page 4.  
<OR>
- Select **Configuration Overrides** to change configurations that will override the global layer for specific locations. The Profile Groups available here are defined in the Profile Maintenance component of Profile Management. See [Profile Management](#) for more information about setting up Profile Groups.
  - a. Select a Profile Group from the list.
  - b. Select an Element from the list.
  - c. Click **Next**.
  - d. Continue with step 3 on page 4.  
<OR>

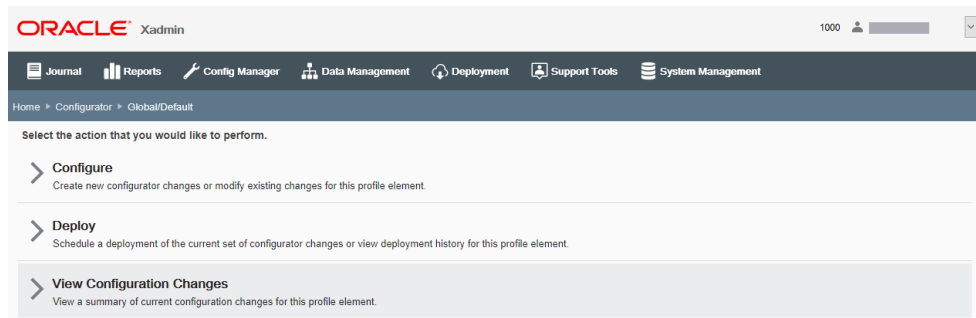
- Select **Store Specific Overrides** to change configurations that will override the global layer for a specific store based on the user's scope.

 **Note:**

Store Specific Overrides scope is only available, if Oracle Retail Xstore Office configuration "Enable the Option to Create Store-Specific Configurations?" is set to **Yes**.

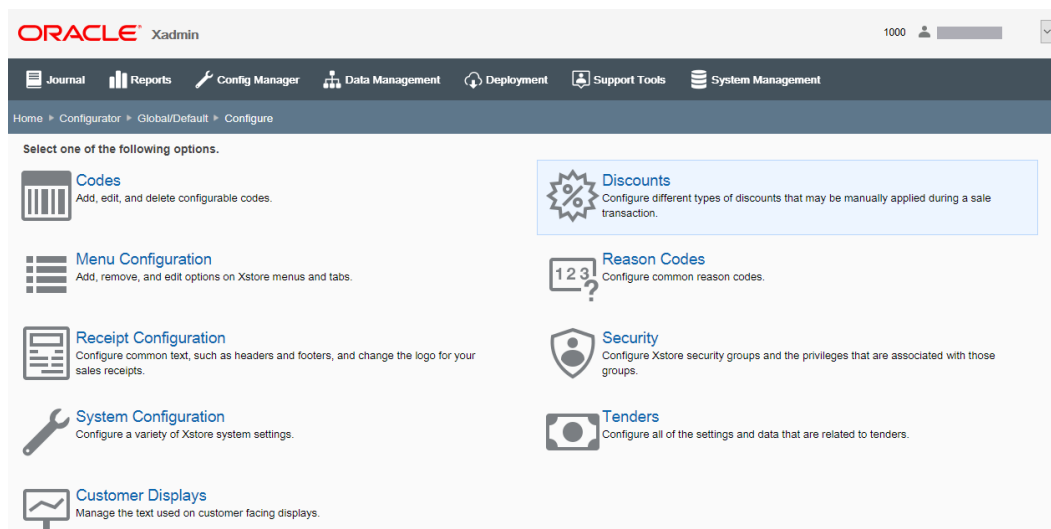
- Type the store number or begin typing a store number or name in the Store # field.
  - Select the store from the store list.
  - Click **Next**.
  - Continue with step 3 below.
- At the Configuration Action page, select the **Configure** option.

**Figure 5-2 Configuration Action Page - Global/Default Scope Example**



- At the Configure Options page, select the area you want to configure:

Figure 5-3 Configure Options Page - Global/Default Scope Example



- If you selected Codes, see [Configuring Codes](#).
- If you selected Discounts, see [Configuring Discounts](#).
- If you selected Reason Codes, see [Configuring Reason Codes](#).
- If you selected Menu Configuration, see [Configuring Menus and Tabs](#).
- If you selected Receipt Configuration, see [Configuring Receipts](#).
- If you selected System Configuration, see [Configuring Xstore Point-of-Service System Config Options](#).
- If you selected Security, see [Configuring Oracle Retail Xstore Point-of-Service Security](#). This option is only available for the Global scope.
- If you selected Tenders, see [Configuring Tenders](#).
- If you selected Customer Displays, see [Configuring Customer Displays](#).

 **Note:**

Use the breadcrumbs, for example Home, Configurator at the top of the page for navigation.

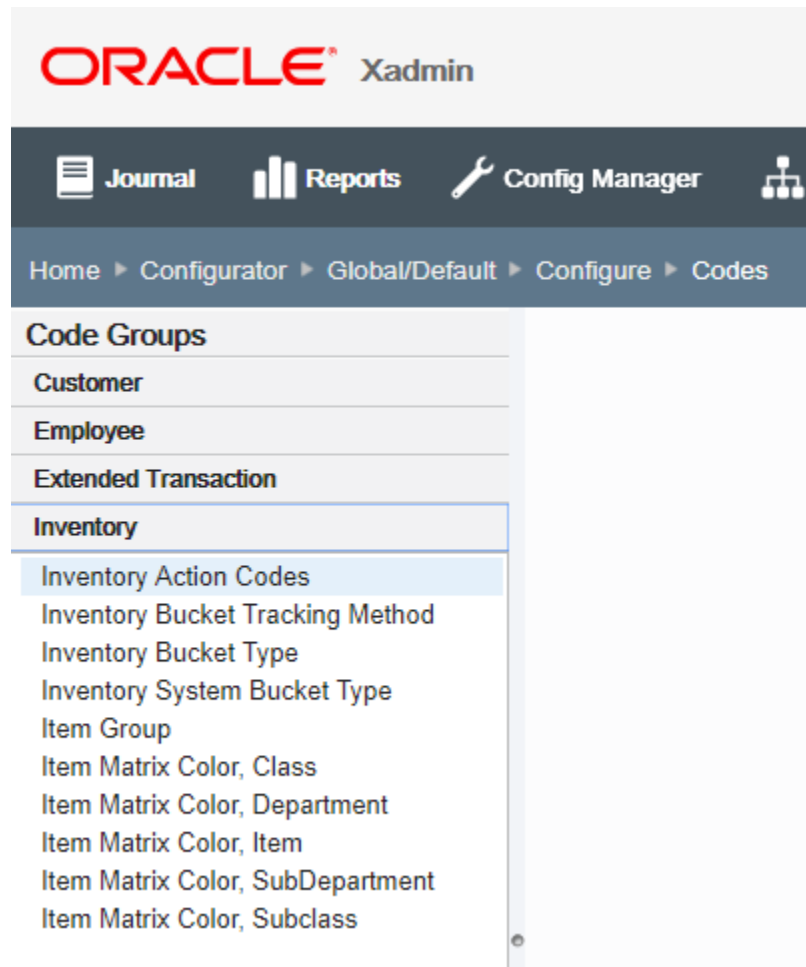
## Configuring Codes

...continued from step 4

1. The Oracle Retail Xstore Point-of-Service codes have been organized by groups. Select a Code Group to view the codes in the group.

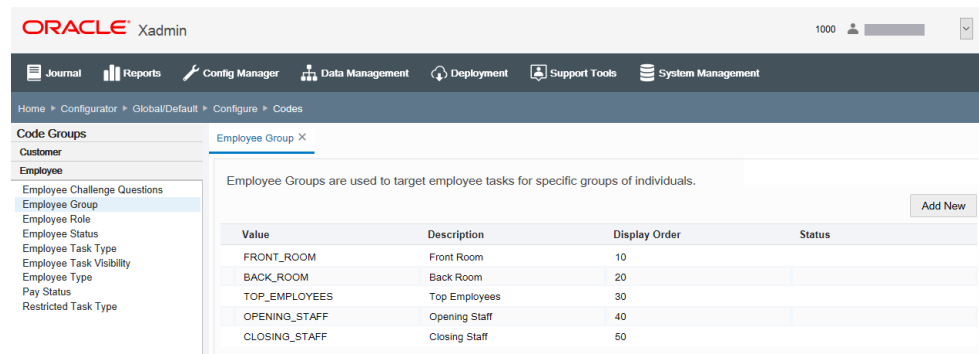


Figure 5-4 Code Groups List - Inventory Codes Group Expanded Example



2. Select a code from the expanded Code Groups list to modify.

Figure 5-5 Configure Codes Page - Employee Group Code Example



3. Add a new code or edit an existing code:

If adding a new code:

- a. Click **Add New**.
- b. Complete the fields as required, then click Save. See [Code Configuration Options](#).

If editing an existing code:

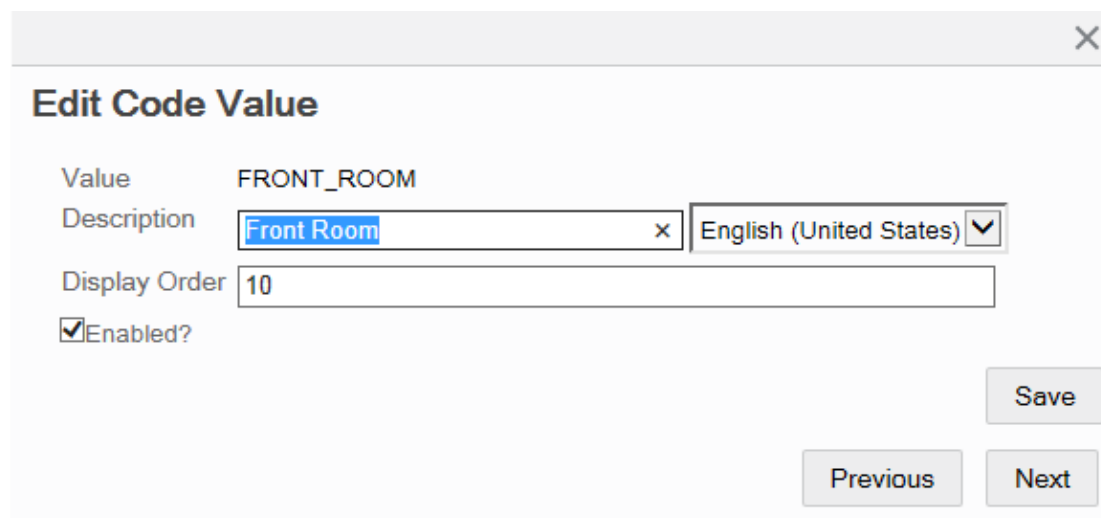
 **Note:**

You can only edit global records if you are in a global configuration.

- a. Select the code in the list.
  - b. Edit the fields as required, then click Save. See [Code Configuration Options](#).
4. After completing code setup, you have the following options:
- To deploy your changes, see [Deploying Configuration Changes](#)
  - To view a summary list of a profile element's configuration changes to identify how it differs from the global configuration, see [Viewing Configuration Changes](#).
  - [CONFIGURATION OVERRIDES & STORE SPECIFIC OVERRIDES ONLY] - To delete the current profile element configuration changes, see [Delete Profile Configuration Overrides](#).
  - [STORE SPECIFIC OVERRIDES ONLY] - To copy store configurations from another store, see [Copy Store Configurations](#).

## Code Configuration Options

**Figure 5-6 Edit Code Value Window**



**Edit Code Value**

Value FRONT\_ROOM

Description

Display Order

Enabled?

Save Previous Next

- Value - The name of the code: required, alphanumeric field. In edit mode, this value cannot be changed.
- Description - A description of the code: not required, alphanumeric field.
- Display Order - Determines the sort order of the code value as compared to other code values for this group.
- Locale - If needed, select a translation locale and enter the description for the locale.

- Image URL - If applicable, specify the URL of the image file. If this does not apply to the selected code, this option is not displayed.
- Rank - If applicable, specify the rank value for this code. If this does not apply to the selected code, this option is not displayed.
- Enabled? - Determines whether this code is available for use. A check mark indicates the code is enabled. The Disabled label in the Status column indicates a code is not available for use.

**Figure 5-7 Configure Codes Page - Disabled Code Example**

The screenshot shows the Oracle Xadmin interface for configuring Employee Challenge Questions. The page title is 'Employee Challenge Questions' and it includes an 'Add New' button. Below the title is a table with the following data:

Value	Description	Display Order	Status
EMP_CHALLENGE_Q1	In what city were you born?	10	Disabled
EMP_CHALLENGE_Q2	What is your mother's maiden name?	20	Disabled

## Configuring Discounts

1. Maintain discounts or set up system configuration options:
  - To maintain discounts, select **Discount Maintenance** and continue with step 2.
  - To set up system configuration options, select **Discount System Configuration** and skip to Discounts System Configuration.
2. Select the type of discount to configure or set up system configuration options:
  - Line Item Discounts - Discounts that apply to an individual line item in a sale transaction.
  - Transaction Discounts - Discounts that apply to all line items in a sale transaction.
  - Group Discounts - Discounts that apply to a selected group of line items in a sale transaction.
3. Add a new discount or edit an existing discount:
 

If adding a new discount:

  - a. Click **Add New**.
  - b. Complete the fields as required, then click **Next**. See [Discount Configuration Options](#) for a list of discount configuration options.
  - c. If editing an existing discount:

Skip to step 4 on page 9 to review your selections.

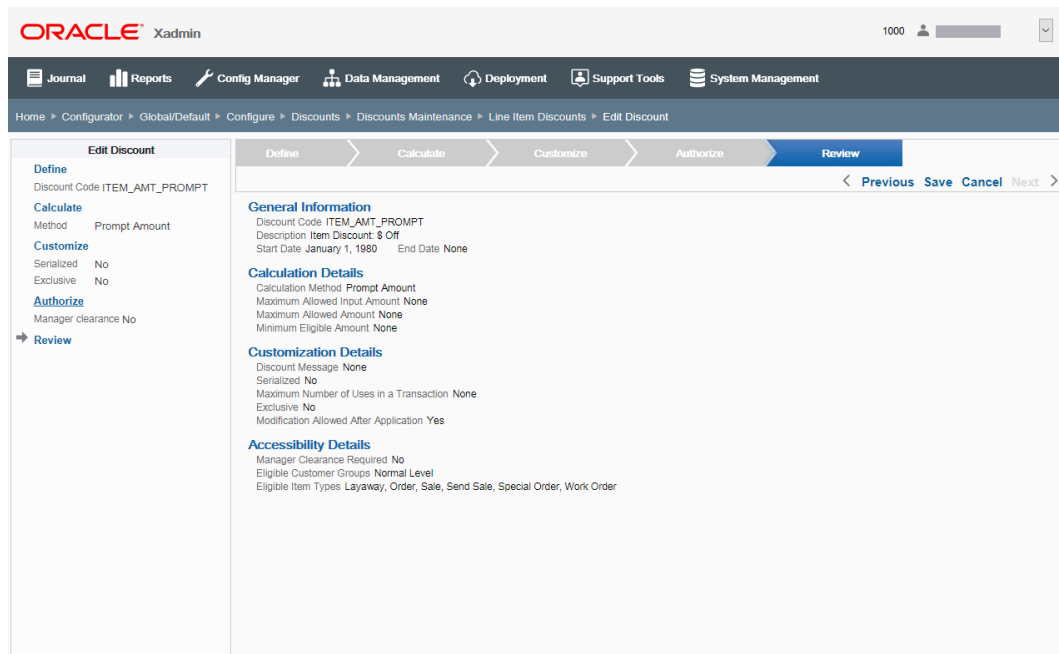
 **Note:**

You can only edit global records if you are in a global configuration.

If you are editing configurations in a specific location (Profile Group or Store), the Edit button in the Discount Detail window will only be available if you have the proper privileges.

- a. Select the discount in the list.
  - b. At the Discount Detail window, click **Edit**.
  - c. Complete the fields as required, then click **Next**. See [Discount Configuration Options](#) for a list of discount configuration options.
  - d. Continue with step 4 on page 9 to review your selections.
4. Review the discount options you selected:

**Figure 5-8 Discount Options Review**



- To save the discount, click **Save**. The discount is added to the Discount list.
  - To edit the discount:
    - Click **Previous** to go back one page.
    - <OR>
  - Select a configuration option in the Edit Discount section in the left panel of the window.
- After making your changes, click **Save**. The new discount is added to the Discount list.

- To discard the discount, click **Cancel**. When prompted, click **Yes** to confirm you want to cancel discount setup.
5. After completing discount setup, Oracle Retail Xstore Office returns to the Discount list page.
    - To deploy your changes, see [Deploying Configuration Changes](#).
    - To view a summary list of a profile element's configuration changes to identify how it differs from the global configuration, see [Viewing Configuration Changes](#).
    - [CONFIGURATION OVERRIDES & STORE SPECIFIC OVERRIDES ONLY] - To delete the current profile element configuration changes, see [Delete Profile Configuration Overrides](#).
    - [STORE SPECIFIC OVERRIDES ONLY] - To copy store configurations from another store, see [Copy Store Configurations](#).

## Discount Configuration Options

This section describes the available discount configuration options.

### Basic Information

1. Define the basic information for the discount, then click **Next**.
  - Discount Code - The code must be unique, and cannot be changed when editing an existing discount.
  - Description - Enter a text description for the discount.
  - Locale for translation - If needed, select a translation locale and enter the description for the locale.
  - Start Date - Enter or select a starting date.
  - End Date - If needed, enter or select an ending date.
  - Discount enabled status check box (enabled by default).

 **Note:**

Discounts cannot be deleted. Disable any discounts you do not want to use.

### Calculation Information

1. Specify how the discount is calculated, then click **Next**.
  - Method - Select a calculation method from the drop-down list.
  - Amount/Percent - If applicable, enter the amount off or percent off. (This field is not active for discounts without a defined amount or percent off).
    - For Prompt Amount discounts, select the "Is there a maximum allowed input amount" option if there is a limit on the free-format discount amount that can be entered in Oracle Retail Xstore Point of Service and enter the amount when prompted.

- For Prompt Percent discounts, select the "Is there a maximum allowed input percentage" option if there is a limit on the free-format discount percentage that can be entered in Oracle Retail Xstore Point of Service and enter the percent when prompted.
- Is there a maximum allowed amount? Select this option if true, and enter the amount when prompted.
- Is there a minimum amount to make this discount eligible? Select this option if true, and enter the amount when prompted.

## Customize Configuration Options

1. Customize the discount features, then click **Next**.
  - Is there a custom message for this discount? - Select this option if true, and enter the custom message when prompted. If needed, select a translation locale and enter the custom message for the locale.
  - Is it serialized? - Select this option if the discount has an associated serial number. For example, it may be used with coupon discounts.
  - Is there a maximum number of times it can be applied in a transaction? - Select this option if true, and enter the maximum number of times it can be applied in a transaction when prompted.
  - Is it exclusive? - Select this option if the discount cannot be used with any other discounts.
  - Can it be modified once it has been applied? - Select this option if the discount can be changed. This option is selected by default (true).

## Discount Accessibility Configuration

1. Configure discount accessibility, then click **Next**.
  - Is manager clearance required to apply this discount? - Select this option if manager override is required to use this discount.
  - Eligible Customer Groups - Select all options that apply. For example:
    - Elite Program Member
    - Employee
    - Employee Family
    - Normal Level
  - Eligible Item Types - Select all options that apply. For example:
    - Layaway
    - Order
    - Sale
    - Send Sale
    - Special Order
    - Work Order

## Discounts System Configuration

 **Note:**

The system configuration options for discounts in this feature are simply a subset of the system configuration options available from Oracle Retail Xstore Point-of-Service System Config Options. See [Configuring Xstore Point-of-Service System Config Options](#) for more information.

The following configurations apply specifically to discounts. The categories have been set up as follows:

- Discount Options
- Returns

### Discount Options

- Enable Discount Threshold Validation? - Determines whether the system validates the total discount amount or percentage against a configured threshold.

 **Note:**

The thresholds establish maximum allowable amounts or percentages used for discounting; beyond these thresholds, the `DISCOUNT_EXCEED_MAX_THRESHOLD` privilege is activated.

- How Should Price Be Rounded After Discount Applied? - The local currency amount rounding method used for determining the price after a discount is applied:
  - Half Up - Round to the nearest neighbor unless equidistant, then round up.
  - Half Down - Round to the nearest neighbor unless equidistant, then round down.
  - Half Even - Round to the nearest neighbor unless equidistant, then round to even neighbor. Example: 2.5 rounds to 2 while 3.5 rounds to 4.
  - Ceiling - Round toward positive infinity. Note: This is the opposite of FLOOR and never decreases the calculated value.
  - Down - Round to the next digit; closer to zero.
  - Floor - Round down toward negative infinity. Note: This is the opposite of CEILING and never increases the calculated value.
  - Up - Round to the next digit; away from zero.
  - Unnecessary - Rounding is not necessary.
- Minimum # of Items That Can Participate In Group Discount - The minimum number of items required in order to allow application of a group discount.

- Minimum Threshold For You Saved Amount? - The minimum amount of customer savings required for the system to print the customer savings information on the sales receipt.
- Precision Decimal Places For Calculating Line Item Discounts - If `LineDiscountUseConfiguredScale` is true, the system uses this scale instead of the local currency scale to round the line item discount amount.
- Print You Saved Amount On Receipts? - Determines whether the system prints customer savings information on the sales receipt.
- Prompt Confirmation On Item Deletion Participating In Group Discount? - Determines whether the system prompts for confirmation if the associate wants to remove an item with a group discount. The group discount will be removed from other items as well.
- Threshold Amount To Measure Line Item Discounts Against - If `DiscountThresholdEnabled` is true, the system validates the total line item discount amount against the threshold amount specified here.
- Threshold Percent To Measure Line Item Discounts Against - If `DiscountThresholdEnabled` is true, the system validates the total line item discount percent against the threshold percent specified here.
- Use Special Precision For Calculating Line Item Discount Amounts? - Determines whether the system uses `LineDiscountPrecision` scale instead of the local currency scale to round the line item discount amount.

## Returns

- Allow Return Items To Be Discounted On Blind Returns? - Determines whether the system allows applying a discount on a blind return (Customer does not present the original sales receipt.) This configuration applies only to line item and group discounts. This configuration does not apply to transaction discounts.
- Allow Return Items To Be Discounted On Unverified Returns? - Determines whether the system allows applying a discount on an unverified return. (Customer presents the original sales receipt but the system is not able to retrieve the original sales transaction.) This configuration applies only to line item and group discounts. This configuration does not apply to transaction discounts.
- Allow Return Items To Be Discounted On Verified Returns? - Determines whether the system allows applying a discount on a verified return. (Customer presents the original sales receipt and the system is able to retrieve the original sales transaction.) This configuration applies only to line item and group discounts. This configuration does not apply to transaction discounts.
- Disable Pro-rated Discounts On Returns? - When this setting is enabled, Oracle Retail Xstore Point of Service will turn off the proration of discounts for returns.

## Configuring Reason Codes

...continued from step 4

1. At the Reason Code Search page, select the Reason Code Type from the list, then click **Next**.
2. The configuration page for the selected reason code type displays. Add a new reason code or edit an existing reason code.

If adding a new reason code:



- a. Click **Add New**.
- b. Complete the fields as required, then click **Next**. See [Reason Code Configuration Options](#) for a list of reason code fields.
- c. Skip to step 3 on page 14.

If editing an existing reason code:

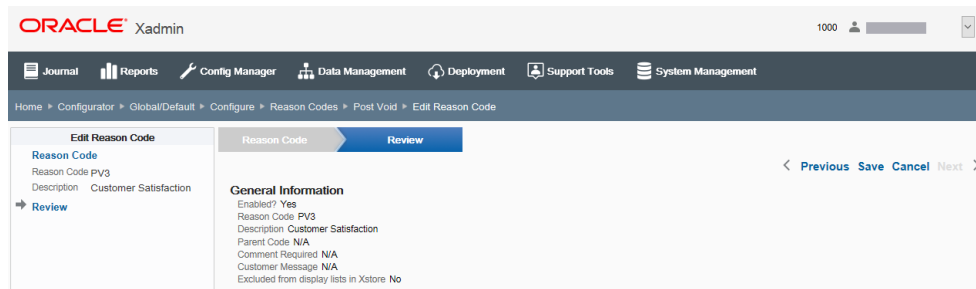
 **Note:**

You can only edit global records if you are editing records in a global configuration.

If you are editing configurations in a specific location (Profile Group or Store), the Edit button in the Reason Code Detail window will only be available if you have the proper privileges.

- a. Select the reason code in the list.
  - b. At the Reason Code Detail window, select **Edit**.
  - c. Complete the fields as required, then click **Next**. See [Reason Code Configuration Options](#) for a list of reason code fields.
  - d. Continue with step 3 below.
3. Review the reason code options you selected:

**Figure 5-9 Reason Code Options Review**



- To save the new reason code, click **save**. The reason code is added to the Reason Codes list.
- To edit the reason code:
  - Click **previous** to go back one screen.
  - <OR>
  - Select a configuration option in the Edit Reason Code section in the left panel of the window.
- After making your changes, click **save**. The new reason code is added to the Reason Codes list.
- To discard the reason code, click **cancel**. Click **Yes** to confirm you want to cancel reason code setup.

4. After completing reason code setup, Oracle Retail Xstore Office returns to the Reason Codes list page.
  - To deploy your changes, see [Deploying Configuration Changes](#).
  - To view a summary list of a profile element's configuration changes to identify how it differs from the global configuration, see [Viewing Configuration Changes](#)
  - [CONFIGURATION OVERRIDES & STORE SPECIFIC OVERRIDES ONLY] - To delete the current profile element configuration changes, see [Delete Profile Configuration Overrides](#).
  - [STORE SPECIFIC OVERRIDES ONLY] - To copy store configurations from another store, see [Copy Store Configurations](#).

## Reason Code Configuration Options

The set of configuration options will vary with the Reason Code Type. This section defines the basic options available for setting up reason codes.

### General Options

- Enabled? - Reason Code enabled status check box. This option is enabled by default. Remove the check mark to disable the reason code.
- Reason Code - The reason code value associated with the reason type code. This value must be unique, and cannot be changed when editing an existing reason code.
- Description - Text description for the reason code.
- Locale for translation - If needed, select a translation locale and enter the description for the locale.
- Does this reason code have a parent code? - If true, select the parent reason code (hierarchy level) upon which the nested reason code is based.
- Does this reason code require that a comment be added? - If true, the POS user will be prompted to add a comment. Specify whether the comment is optional (Prompt to add comment), or if the comment is required (Comment is required).
- Does this reason code need to display a customer message? - If true, enter the customer message to be displayed when the reason code is selected in the POS system. If needed, select a translation locale and enter the customer message for the locale.
- Should this reason code be excluded from reason code lists displayed in Xstore? - Select this option if this reason code will not be available to the Oracle Retail Xstore Point-of-Service POS user.

### Inventory Adjustment Options

- What is the inventory action code for this reason code? - If this reason code has an inventory action code, select the code from the list to specify the inventory action (add or subtract from inventory) to be taken based on the reason code.

### Paid In/Paid Out Options

- Does the reason code have a General Ledger Account Number? - If this reason code is associated with a General Ledger account, enter the General Ledger account number to be recorded when the reason code is selected in Oracle Retail Xstore Point of Service.

- Does the reason code require a minimum amount? - If true, enter the minimum monetary amount allowed for this reason code.
- Does the reason code require a maximum amount? - If true, enter the maximum monetary amount allowed for this reason code.

## Return Reason Code Options

- What inventory location ID is affected by this reason code? - Select the inventory location ID to which the item will be returned.
- What inventory bucket ID is affected by this reason code? - Select the inventory bucket ID within the location to which the item will be returned.

## Properties [Country Pack ONLY]

For the country pack Italy you can associate the Tax Exemption reason code to the country specific exemption code in the Properties tab.

### Note:

This feature is only available for country packs. For more information on country packs, see the *Xstore Suite Configuration Accelerator Guide*.

## Configuring Menus and Tabs

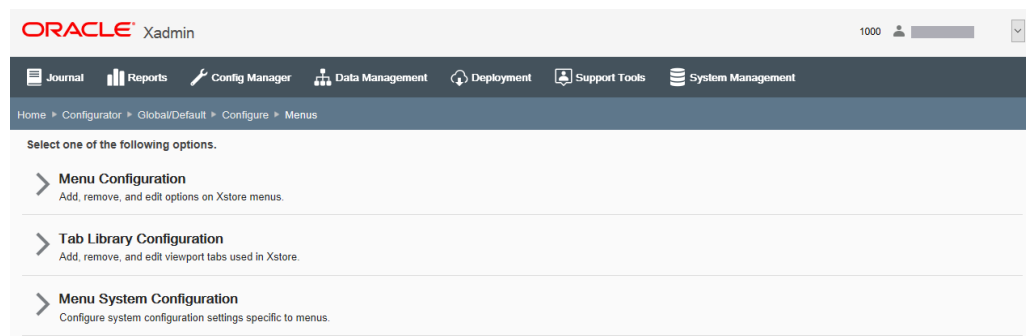
### Note:

Use of the Menu Configuration and Tab Configuration tools assumes some knowledge of the Oracle Retail Xstore Point-of- Service menus and tabs and how they are used in the Oracle Retail Xstore Point-of-Service application.

...continued from step 4

Select a menu option:

**Figure 5-10 Menu Options**



- Select **Menu Configuration** to add, remove, and edit options on Oracle Retail Xstore Point-of-Service menus. Continue with Oracle Retail Xstore Point-of-Service Menu Configuration below.
- Select **Tab Library Configuration** to add or remove message area tabs used in Oracle Retail Xstore Point of Service. Skip to Oracle Retail Xstore Point-of- Service Ta b Configuration.
- Select **Menu System Configuration** to configure the system configuration settings that are specific to menus. Skip to Menu System Configuration.

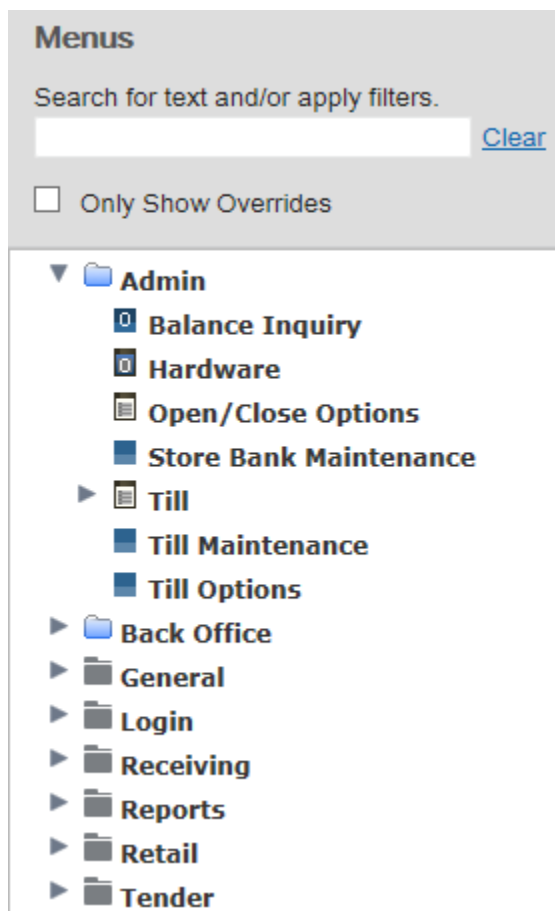
## Oracle Retail Xstore Point-of-Service Menu Configuration










This section describes the Xstore POS Menu configuration.

### About menu categories

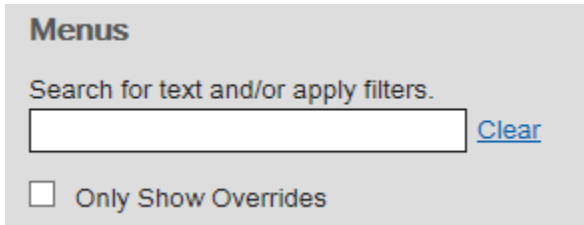
The Oracle Retail Xstore Point-of-Service menus have been organized by categories. For example, all menus with a category of Back Office will be grouped together under the Back Office category name and all menus with the category Tender will be grouped together under the Tender category name.

**Figure 5-11** Menu Categories



-  This is a Menu Category folder. All menus belonging to this category are located in this folder.
-  A blue Menu Category folder indicates a menu within the folder has been modified.
-  This icon indicates there are additional menus nested below this list menu type.
-  This icon indicates there are additional menus nested below this button menu type.
-  This icon indicates this is the lowest level for this list menu type. There are no menus nested below this menu.
-  This icon indicates this is the lowest level for this button menu type. There are no menus nested below this menu.
-  This icon indicates this list menu type has been modified.
-  This icon indicates this button menu type has been modified.
-  This icon indicates that this menu also appears in other Categories. Any changes made to this menu in one category will also be applied to the menu in all the categories where it appears.
- To find menus containing specific text, enter the search text in the input box, then press **[Enter]**. The results are shown in the left panel (folder tree). Only those menus containing the specified text are displayed. If needed, click **Clear** to remove the search criteria and return to the default Menu Configuration page.

**Figure 5-12 Menu Search Area**



**Menu**

Search for text and/or apply filters.

 [Clear](#)

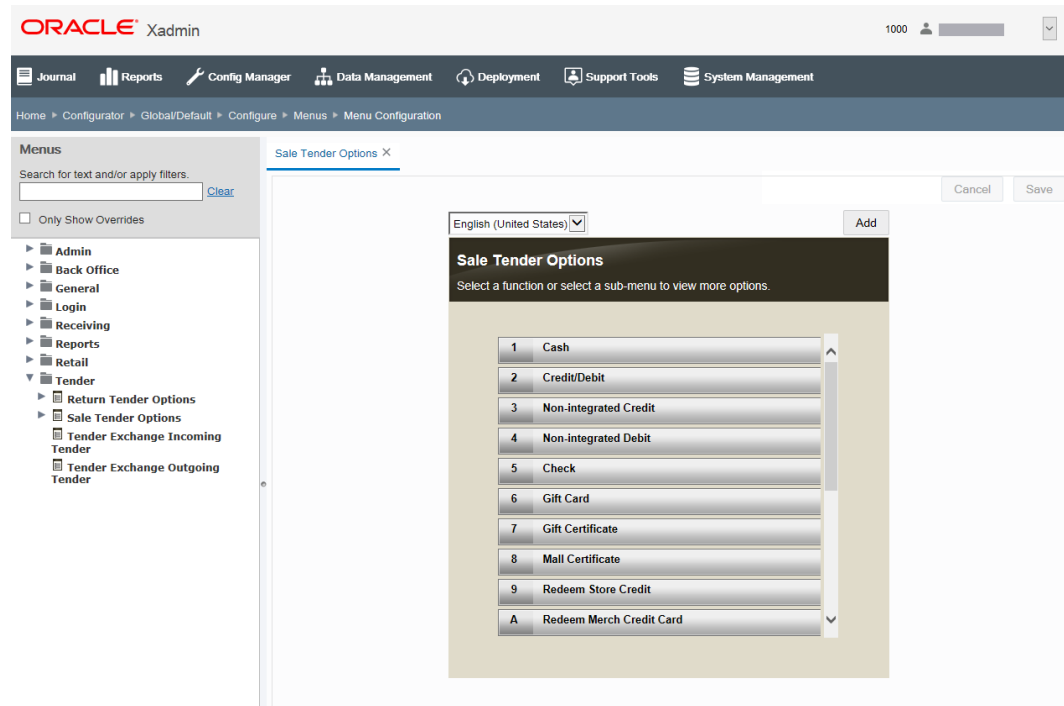
Only Show Overrides

- Click the Only Show Overrides check box to view only the Menu Categories and menus that have been changed.

Perform the following steps to configure Oracle Retail Xstore Point-of-Service menus.

1. After selecting Menu Configuration at the Menu Options page (Figure 5-10), click the menu category from the Menus tree that you want to configure.

**Figure 5-13 Menu Configuration Page - Menu Categories**



2. With the category expanded, click the menu you want to configure.
3. You have the following configuration options:
  - Edit existing menu options:
    - To change the menu text, see [Changing the Menu Text](#).
    - To remove a menu option, see [Removing a menu option](#).
  - To change a menu option location, see [Changing a Menu Option Location](#).
    - Add a new menu option. See [Adding a New Menu Option](#).
4. After completing menu setup, you can perform the following options
  - To deploy your changes, see [Deploying Configuration Changes](#).
  - To view a summary list of a profile element's configuration changes to identify how it differs from the global configuration, see [Viewing Configuration Changes](#).
  - [CONFIGURATION OVERRIDES & STORE SPECIFIC OVERRIDES ONLY] - To delete the current profile element configuration changes, see [Delete Profile Configuration Overrides](#).
  - [STORE SPECIFIC OVERRIDES ONLY] - To copy store configurations from another store, see [Copy Store Configurations](#).

## Editing an Existing Menu

With the menu displayed, edit the menu as needed.

Figure 5-14 Menu List Example

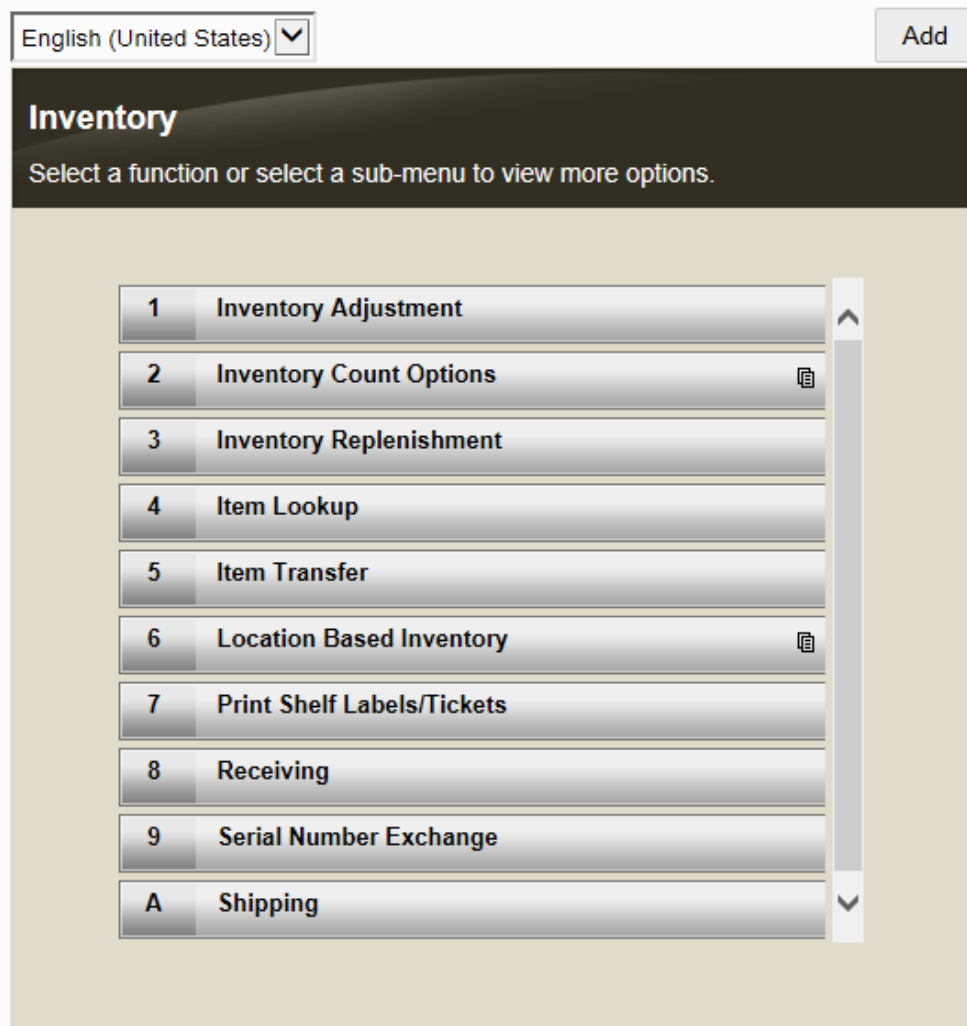
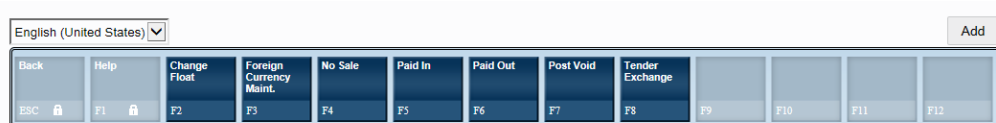


Figure 5-15 Menu Button Example



Refer to the following sections for procedural information.

## Changing the Menu Text

1. Select the menu option to be changed and type the new menu name in the text field below the menu. The old text is replaced by the new text you typed.

Figure 5-16 Menu List Example - New Text

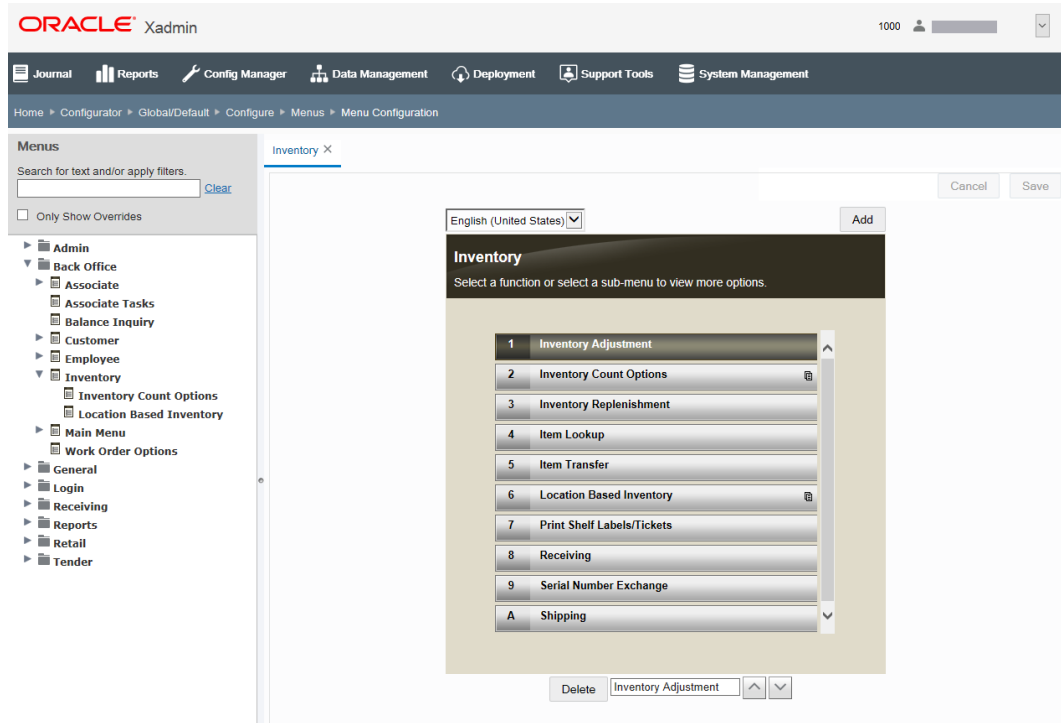
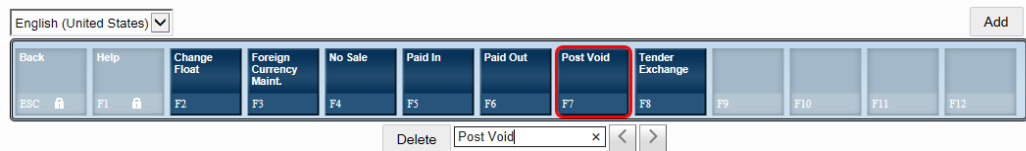
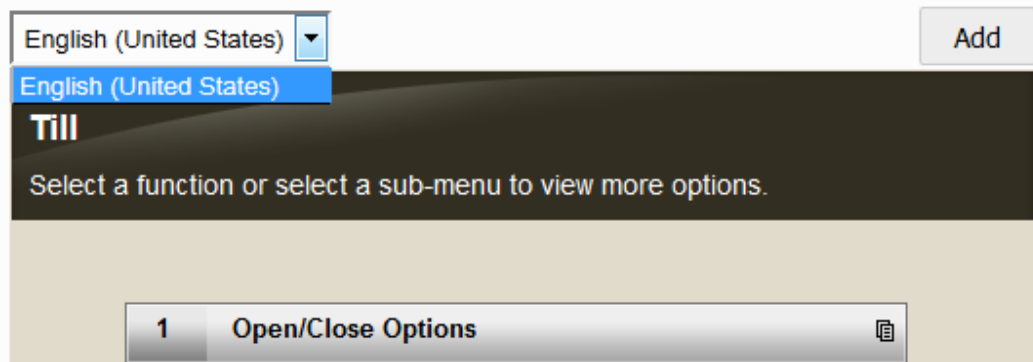


Figure 5-17 Menu Button Example - New Text




- [OPTIONAL] Select a locale to view the menu as it will be displayed in a different locale. This option will only show the locales set up for you organization.

Figure 5-18 Available Locales List



- Click **Save**.

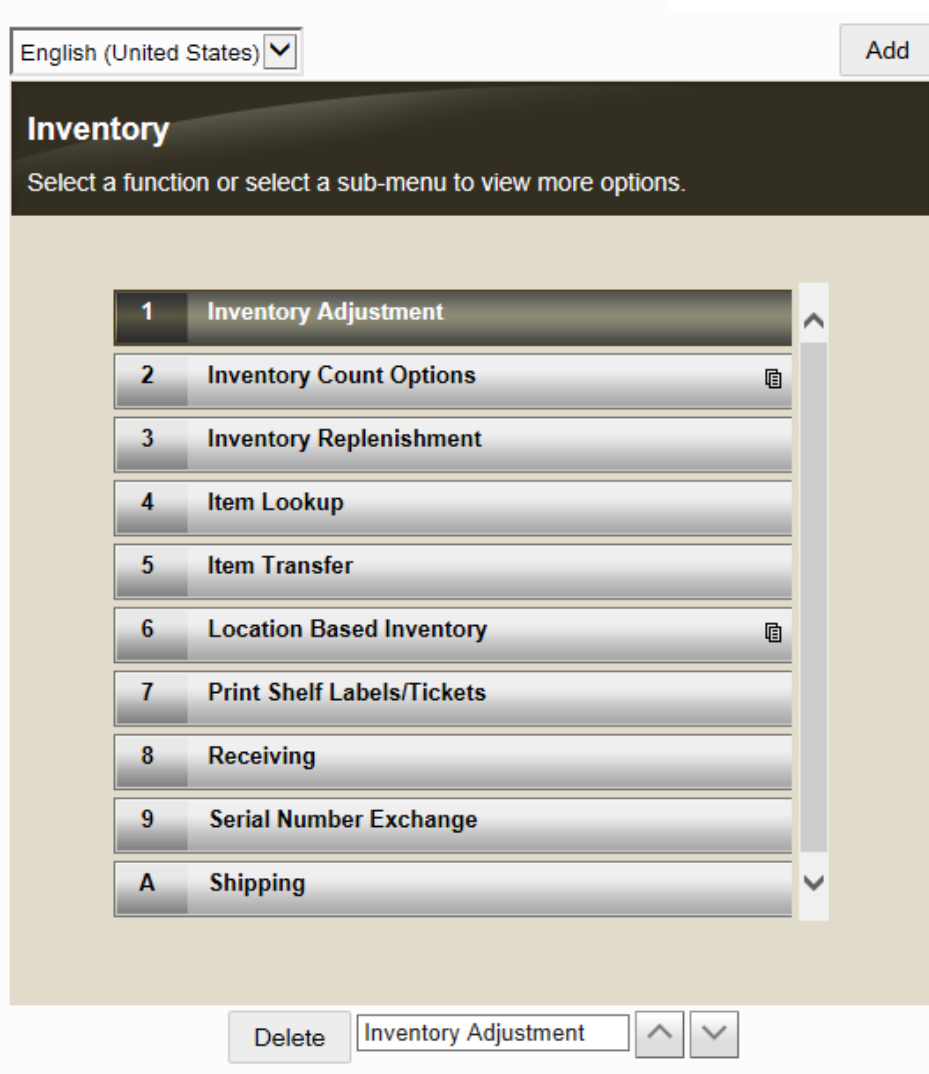


- The  red icon in the tab indicates this configuration change has not been saved
- To close the tab, click the Close icon. You will be prompted if there are unsaved changes.
- Click **Cancel** to discard your changes.

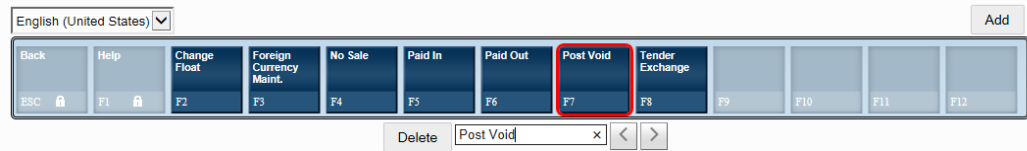
## Removing a menu option

1. Select the menu option to be removed and click the **Delete** button. The menu option will be removed from the menu. The other menus will be shifted accordingly.

**Figure 5-19** Menu List Example - Delete Selected Menu



**Figure 5-20 Menu Button Example - Delete Selected Menu**



 **Note:**

If needed, click **Cancel** if you want to discard your changes before saving.


2. Click **Save**.

## Changing a Menu Option Location

For Menu Buttons:

1. Select the menu button to be moved and click the Left and Right arrows to change the menu button location within the menu. The other menu buttons will be shifted accordingly.

 **Note:**

The Locked icon  associated with a menu button indicates this button is "locked" in this location and cannot be moved. The Left and Right arrows will be disabled since the menu button cannot be moved.

 **Note:**

Click **Cancel**, if you want to discard your changes before saving.

2. Click **Save**.

For Menu Lists:

1. Select the menu option to be moved and click the Up and Down arrows to change the menu option location within the menu. The other menus will be shifted accordingly.

 **Note:**

Click **Cancel**, if you want to discard your changes before saving.

2. Click **Save**.

## Adding a New Menu Option

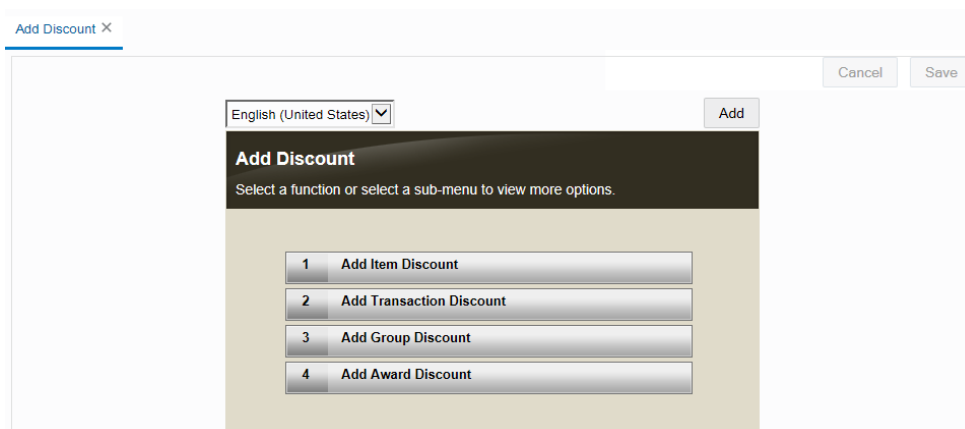


### Note:

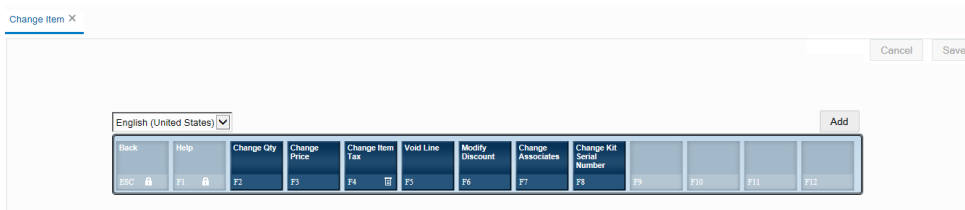
Adding new options to menus assumes you have a working knowledge of how and where the menus are used in the Oracle Retail Xstore Point-of-Service application.

1. With the menu displayed, click **Add**.

**Figure 5-21** Menu List Example

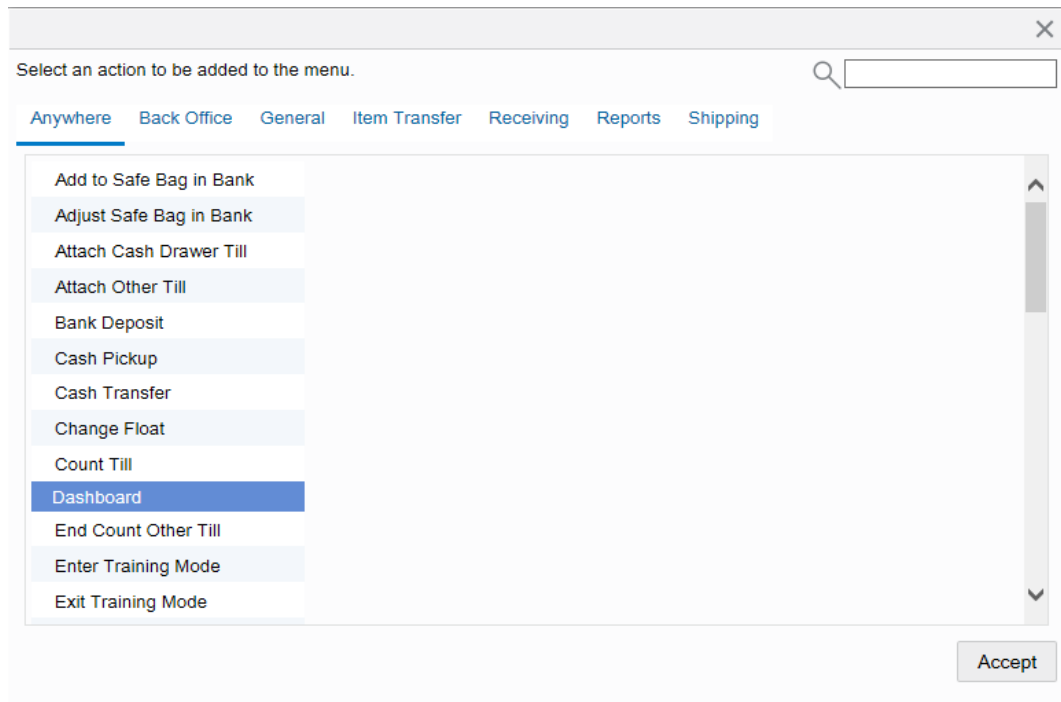


**Figure 5-22** Menu Button Example



2. At the Add Action window, select a menu option to be added to the selected menu and click **Accept**.

**Figure 5-23 Add Action Window**



 **Note:**

To find a menu option quickly, type the name in the search field. Clicking **Cancel** will return to the menu without making any changes.

3. When prompted, click the location for the new menu option. The other menu options will be adjusted accordingly if needed.

Figure 5-24 Menu List Example - New Menu Option Location

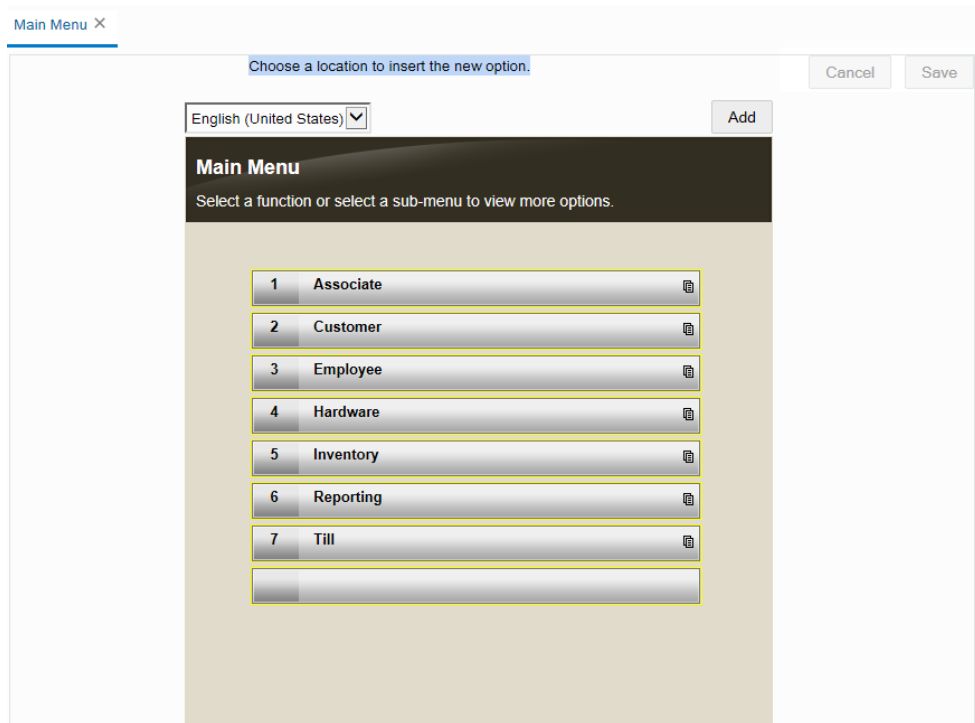
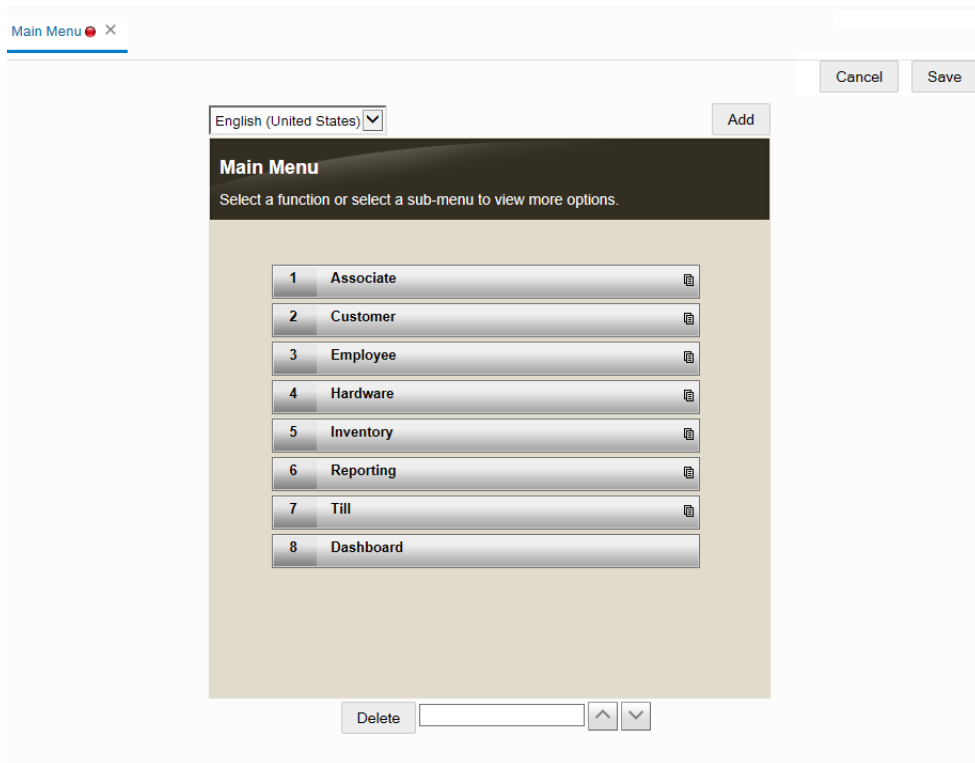


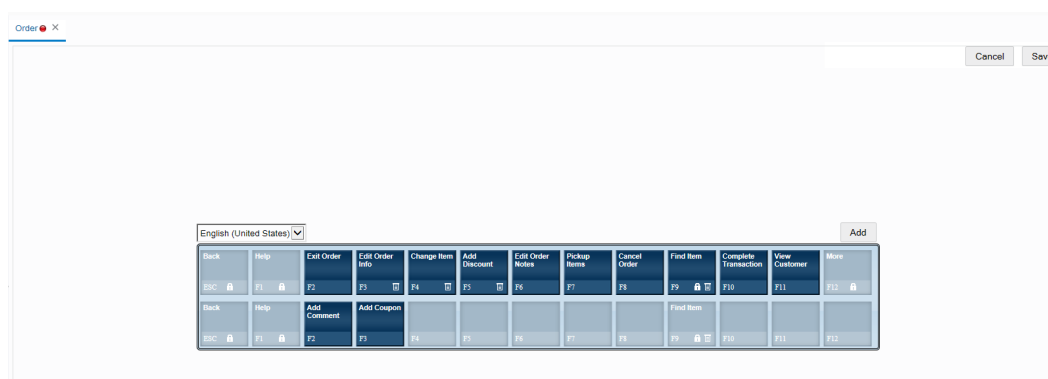
Figure 5-25 Menu List Example - New Menu Option Added



**Figure 5-26 Menu Button Example - New Menu Option Location**



**Figure 5-27 Menu Buttons Example - New Menu Option Added**



**Note:**

In the menu button example shown above, the **More** button was added automatically to accommodate the new menu option.

4. Click **Save**.

## Oracle Retail Xstore Point-of-Service Tab Configuration

The Oracle Retail Xstore Point-of-Service Tab Library contains a set of ready-to- implement tabs and widgets that can be easily incorporated into Oracle Retail Xstore Point of Service to enhance the user experience. The Tab Library provides multiple options for information tabs and web widgets, beyond the five standard tabs traditionally provided in the Information area with base Oracle Retail Xstore Point of Service. You can select from an array of pre-defined widgets and tabs in the library to be displayed in Oracle Retail Xstore Point of Service.

In addition, these tabs can be configured to work in different contexts. For example, tabs that display login mode may not be the same tabs that are available during transaction mode.

 **Note:**

Additional configuration may be required to set up the information found on the various tabs. The tab configuration feature described here is used to manage which pre-defined tabs are used in Oracle Retail Xstore Point of Service and where they will appear.

Security privileges are required to use this feature:

**Table 5-3 Security Privileges**

Security Privilege	Description
Configurator	This privilege allows the user to access the menu config option form the configurator lading page.
Menu Configuration	This privilege allows the user to access the actual menu config feature
Tab Configuration	This privilege allows the user to access the tab library config feature.

The base implementation of Oracle Retail Xstore Point of Service displays five information tabs: Info, Tasks, (Sales) Goals, Messages, and Keypad. The tabs and widgets in the library can be used in place of-or in addition to-the tabs provided with base Oracle Retail Xstore Point of Service.

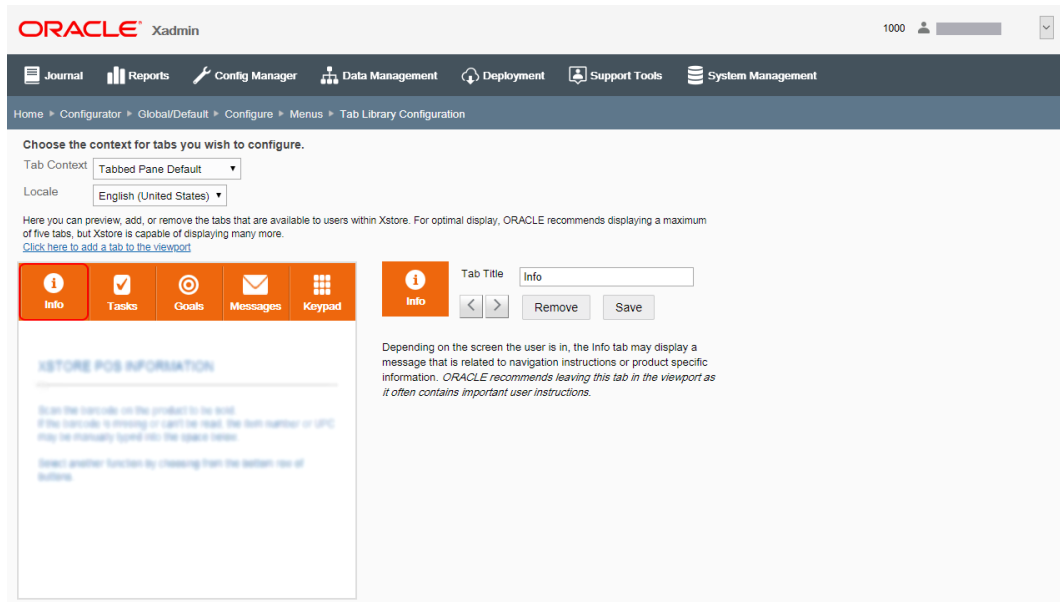
 **Note:**

It is possible to add more or less than the standard five tabs delivered in base Oracle Retail Xstore Point of Service; however, for best results a limit of five tabs per context is recommended.

Perform the following steps to configure which tabs will be in use, and where they will be displayed.

1. After selecting Tab Library Configuration at the Menu Options page, the Tab Library Configuration page displays.

Figure 5-28 Tab Library Configuration Page



 **Note:**

This page shows the current tab layout for the selected context (Default or Transaction). Any text located within the tab area will appear blurred and is simply shown to illustrate the tab's content.

2. At the Tab Library Configuration page, choose the tab context from the drop-down list:
  - Tabbed Pane Default - The tabs that are available when not in a transaction.
  - Tabbed Pane Transaction - The tabs that are available during a transaction.
3. [OPTIONAL] Select a locale to view the tab as it will be displayed in a different locale. This option will only show the locales set up for you organization.
4. Choose from the following options for the selected tab context:
  - To add a new tab, see [Adding a New Tab](#).
  - To remove a tab, see [Adding a New Tab](#).
  - To move a tab, see [Moving a Tab Position](#).
  - To change the tab name, see [Changing a Tab Name](#).
5. After saving the tab configuration, you can perform the following options:
  - To deploy your changes, see [Deploying Configuration Changes](#).
  - To view a summary list of a profile element's configuration changes to identify how it differs from the global configuration, see [Viewing Configuration Changes](#).
  - [CONFIGURATION OVERRIDES & STORE SPECIFIC OVERRIDES ONLY] - To delete the current profile element configuration changes, see [Delete Profile Configuration Overrides](#).



- [STORE SPECIFIC OVERRIDES ONLY] - To copy store configurations from another store, see [Copy Store Configurations](#).

## Adding a New Tab

1. At the Tab Library Configuration page, click the Click here to add a tab to the viewport link.
2. Select a tab from the list and click the **Add** button. The tab is added to the information area image.

 **Note:**

To close the Add Tab window without making any changes, click the Close button.

3. If needed, override the default field(s).

 **Note:**

For the URL tab, the POS Terminal must have rights to view the URL website through security and fire wall settings maintained by the corporate office.

4. Click **Save** to save your changes.

## Removing a Tab

1. At the Tab Library Configuration page, click the tab you want to remove.
2. With the tab selected, click the **Remove** button.
3. When prompted, click **Yes** to confirm you want to remove the selected tab. The tab is removed from the information area image.
4. Click **Save** to save your changes.

## Moving a Tab Position

1. At the Tab Library Configuration page, click the tab you want to move.
2. With the tab selected, click the navigation buttons to move the selected tab's position left or right.
3. Click **Save** to save your changes.

## Changing a Tab Name

1. At the Tab Library Configuration page, click the tab you want to rename.
2. With the tab selected, type a new name for the tab.
3. Click **Save** to save your changes.

 **Note:**

Although the tab name is not a required field in Oracle Retail Xstore Office, Oracle Retail Xstore Point of Service expects a name and will display a translation error if the name is not specified here.

## Menu System Configuration

 **Note:**

The system configuration options for menus in this feature are simply a subset of the system configuration options available from Oracle Retail Xstore Point-of-Service System Config Options. See [Configuring Xstore Point-of-Service System Config Options](#) for more information.

The following configurations apply specifically to menus. The categories have been set up as follows:

- [Help](#)
- [Register Configuration](#)
- [Store Specific](#)

### Help

**Name Of Help Menu** - The menu to be displayed when the Help button is selected. The set of actions to be run for the menu are defined in MenuConfig.xml.

### Register Configuration

**The Number Of Buttons On A Menu** - This determines the number of buttons on a menu. Users are required to make a corresponding change to UIConfig.xml. These settings will not impact the menu layout of the Oracle Retail Xstore Point-of-Service Software Mobile which will remain fixed at a 3 x 2 grid.

### Store Specific

**Hide Menu Options From Users That Lack Access** - This is used to hide menu options the user does not have security privileges to use. Answer yes to hide the menu option completely. Answer no to display the option as disabled.

# Configuring Receipts

**Note:**

Receipt configuration is limited to certain receipts, and to specific areas within those receipts.

...continued from step 4

1. Select a receipt option:
  - Find Receipt By Transaction - Select this option if you want to make your edits based on a specific receipt from a known transaction. See [Finding the Receipt by Transaction](#).
  - Find Receipt By Type - Select this option if you want to make your edits based on a specific type of receipt. See [Finding the Receipt by Type](#).
  - Change Receipt Logo - Select this option to change the logo that displays on your sales receipts. See [Changing the Receipt Logo](#).
  - Receipt System Configuration - Select this option to configure system configuration settings specific to receipts. See [Receipt Configuration: System Configuration Options](#).
2. After completing receipt setup, you can perform the following options:
  - To deploy your changes, see [Deploying Configuration Changes](#).
  - To view a summary list of a profile element's configuration changes to identify how it differs from the global configuration, see [Viewing Configuration Changes](#).
  - [CONFIGURATION OVERRIDES & STORE SPECIFIC OVERRIDES ONLY] - To delete the current profile element configuration changes, see [Delete Profile Configuration Overrides](#).
  - [STORE SPECIFIC OVERRIDES ONLY] - To copy store configurations from another store, see [Copy Store Configurations](#).

## Finding the Receipt by Type

**Note:**

For a receipt type to be available here, an actual transaction must exist that uses the receipt type.

1. Select a receipt type (and a locale if applicable) from the list and click **Search**.

Figure 5-29 Receipt Search by Type

**Find Receipt By Type**  
Find receipts by selecting a specific type of receipt.

Locale English (United States) ▾

Type

- Sale
- Credit Card
- Tax Exemption
- Account Receivable
- Bounce Back Coupon
- Gift Certificate
- Layaway
- Special Order
- Send Sale
- Work Order
- Order
- Rain Check
- Warranty

Search

 **Note:****Searching For Receipts By Type**

The Locale drop-down field defaults to the locale of the current user. Locale is used to find the selected receipt types that match to the selected locale. For example, if Espanol is selected from the Locale list, only those receipts that are assigned to the Espanol locale will be displayed.

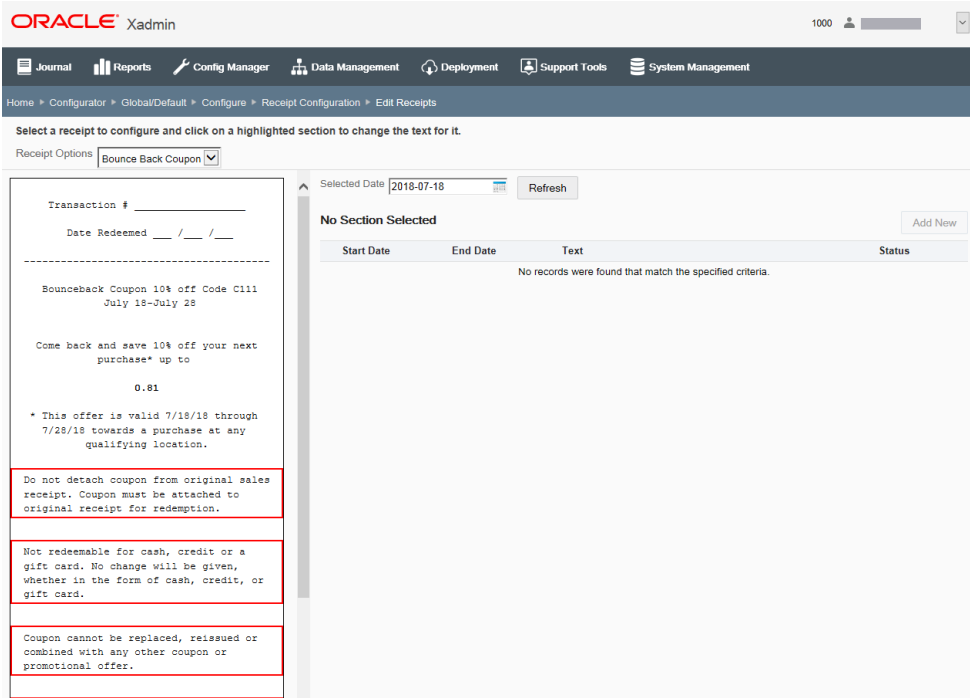
If the search yields no results, a message is shown below the receipt list.

2. At the Receipt Configuration page, select a receipt from the Receipt Options drop-down list. The Receipt Options drop-down list contains the various receipts available for the selected receipt type.
3. The Edit Receipts page displays.

 **Note:**

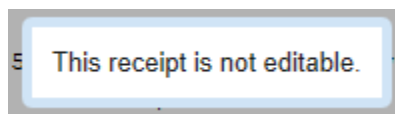
The initial view of the Edit Receipts page automatically displays the first receipt type in the drop-down list.

**Figure 5-30 Edit Receipts Page - Bounce Back Coupon Receipt Example**

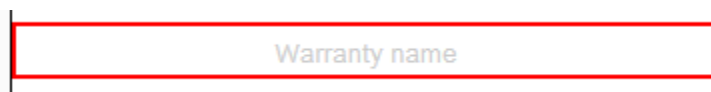


**About the Edit Receipts Page**

- The calendar date and receipt view default to the current day. If applicable, use the calendar to select another date to view the receipt with the text entries for that specific date. Click the Refresh button to update the receipt for the new date.
- If the receipt you selected cannot be edited, you will see this message and the receipt will appear as a gray image. You can select another receipt from the list, or use the navigation breadcrumbs to return to the previous screen.



- Only receipt sections highlighted in red can be edited.
- If a receipt section is not enabled for the current receipt, the section is shown as a watermark with a white background and gray text, but can be edited.



4. Click on an area of a receipt that is highlighted in red to change it. The selected section will be highlighted in green to indicate it is the active section. The text area on the Edit Receipts page shows all existing entries for the selected section and the effective dates if applicable.

5. At the Edit Receipts page, add new text or edit existing text:
  - To edit an existing line of text, click the text line to open the Edit Receipt Text window and make your receipt changes as needed.
  - To add new text, click the **Add New** button to open the Edit Receipt Text window and add new text as needed.

**Figure 5-31 Edit Receipt Text Window**

**Edit Receipt Text**

Text Code Bounce Back 5  
Text Subcode Default

Is this text enabled?

Start Date 2018-09-24 End Date 2018-09-28

**B** / **U** **Wide** **Tall**

English (United States)

Up to two coupons per transaction will be honored this week.

Save

Previous Next

#### Edit Receipt Text Window

- a. Receipt Text - Type the text as it should appear on the selected section of the receipt.
- b. Dates - [OPTIONAL] Date fields are not required. If there are no dates for a row, the text will always be displayed for the selected section. To create date-defined text for the selected section of the receipt, enter a Start Date and End Date for the length of time the text will be printed on the receipt. This provides the ability to set up future text for each section in a receipt without affecting the current receipt. Leave the End Date field blank if there is no ending date. Leave both date fields blank if there are no date restrictions. To view the receipt changes for a specific date, select the date and click **Refresh**.
- c. Locale - [OPTIONAL] To add or edit receipt text for a different locale, select a locale from the locale drop-down list and enter translated text. This option is only available if multiple locales have been set up for your organization.

- d. Text Format - [OPTIONAL] Use the following icons to format the text on the receipt. When an icon is selected, the format will be applied to all of the text in the box, even if only part of the text was selected at the time. When a format option is selected, the icon changes to a blue background. If you need to remove a format from the text, click the blue icon to remove the formatting. The icon will now be white, indicating the format is not applied.

**Table 5-4 Icons**

Icon	Description
Bold icon	Click this icon to make the text bold.
Italic icon	Click this icon to italicize the text.
Underline icon	Click this icon to underline the text. When choosing to underline text, most receipt printers will underline the entire row whether there is text there or not. For example: <u>Thanks for shopping!</u> Oracle Retail Xstore Office displays the full underline on the Receipt view; however, it is not shown in the text area of the page.
Wide icon	Click this icon to make the text double wide. Oracle Retail Xstore Office displays the double-wide text spacing on the Receipt view; however, it is not shown in the text area of the page.
Tall icon	Click this icon to make the text double high. Oracle Retail Xstore Office cannot display the double-high text on the Receipt view or in the text area of the page.

- e. Disabled/Enabled - The receipt text is enabled by default. To disable the receipt text, click the Is this text enabled? check box to remove the check mark. Disabled text is not shown in the receipt view.
6. Click **Save**.
7. The receipt view displays and shows your changes using the updated Start date.

**Figure 5-32 Edit Receipts Page - Modified Receipt Text Example**

Select a receipt to configure and click on a highlighted section to change the text for it.

Receipt Options: Bounce Back Coupon

Selected Date: 2018-09-26 Refresh

**Bounce Back 5** Add New

Start Date	End Date	Text	Status
Sep 24, 2018	Sep 28, 2018	Up to two coupons per transaction will be honored this week.	

Text boxes (from top to bottom):

- Do not detach coupon from original sales receipt. Coupon must be attached to original receipt for redemption.
- Not redeemable for cash, credit or a gift card. No change will be given, whether in the form of cash, credit, or gift card.
- Coupon cannot be replaced, reissued or combined with any other coupon or promotional offer.
- Up to two coupons per transaction will be honored this week.
- Coupon cannot be applied to employee purchases or for the purchase of gift cards.

**Note:**

If there are multiple entries with the same or overlapping dates, the entries will all display on the receipt. Order will be determined by when the row was added. The order on the receipt will match the order in the text area of the Edit Receipts page.

## Finding the Receipt by Transaction

1. Complete all the fields to locate the receipts from a specific transaction: Store number, Date the transaction was completed, Register identifier where the transaction was rung, and the Transaction number.

**Figure 5-33 Receipt Search by Transaction - Input Fields**

**Find Receipt By Transaction**  
Find receipts using the identifying information from a specific transaction.

Store  Register #

Date  Trans #

Search

2. Click **Search** to return a list of the receipts for the transaction.
3. Continue with step 3 on page 31. The process for modifying receipts either by transaction receipt or by receipt type is the same from this point forward.



## Changing the Receipt Logo

About the logo file format

- Only black and white images may be used.
- Only bitmap (.bmp) format is supported.
- File size cannot exceed 100KB.
- Image width cannot exceed 400 pixels.

To change the current logo follow the steps below:

1. With your current logo displayed, click the **Change** button.
2. Click **Browse** to browse for the new logo file for the receipt.
3. After locating the correct file, click **Upload** to import the file.
  - If this is not the logo you want to use, click **Browse** to find a different logo.
  - If the file format for the new logo you selected is not supported, you will received a corresponding message. Click **Browse** to find a different logo.
4. With the new logo displayed, click **Save**.
5. The new logo is now shown in the Current Logo section of the page.

## Receipt Configuration: System Configuration Options

The following configurations apply specifically to receipts. The categories have been set up as follows:

- [Charity](#)
- [Comission Options](#)
- [Discount Options](#)
- [Email Settings](#)
- [Gift Receipts](#)
- [Gift Registry](#)
- [Inventory Location Based](#)
- [Item Options](#)
- [Kit Options](#)
- [Layaway](#)
- [Loyalty Options](#)
- [Send Sale](#)
- [Till Accountability](#)
- [Training Mode](#)
- [Transaction Behavior](#)

 **Note:**

The system configuration options for receipts in this feature are simply a subset of the system configuration options available from Oracle Retail Xstore Point-of-Service System Config Options. See [Configuring Xstore Point-of-Service System Config Options](#) for more information.

## Charity

- **Enable Printing Charitable Contribution Line Item On The Receipts?** - Enable/Disable the donation line item being printed on the receipts.
- **Enable Printing Charity Footer Message On The Receipts?** - Enable/Disable the charity footer message being printed on the receipts.

## Comission Options

- **Print Sales Associate First Name On Receipts?** - Determines whether the system prints the first name of the current transaction's commissioned associates on the sales receipts.
- **Print Sales Associate Last Name On Receipts?** - Determines whether the system prints the last name of the current transaction's commissioned associates on the sales receipts.
- **Print Sales Associates Using Multiple Lines On Receipt?** - Determines whether the system prints each commissioned associate on a new line (Yes) or all commissioned associates on one line (No) on the sales receipts.

## Discount Options

- **Minimum Threshold For You Saved Amount.** - Enter the minimum amount of customer savings required for the system to print the customer savings information on the sales receipt.
- **Print You Saved Amount On Receipts?** - Determines whether the system prints customer savings information on the sales receipt.

## Email Settings

- **Default Email Host?** - Specify the default email host name used for emailing customer receipts.
- **Default Receipt Email Subject.** - Specify the default subject for an emailed receipt. The value is specified in translations\_en.properties.
- **Font Settings For The Email Text Used When Sending Receipts.** - Specify the font family and size for email receipt text.
- **Prompt To Email Receipts?** - Determines whether users are always prompted with the option to email receipts to customers.
  - Select **Yes** to always prompt to ask the customer if they want receipts emailed.
  - Select **No** and the system will check the email permissions for the customer and will only email if the permission is set to yes.

- **Save Updated Email Address To Customer Record?** - Determines whether customer email addresses are updated and saved to the customer record during the process of emailing a transaction receipt.
- **Send Receipts Via Email?** - This is the global on/off switch for sending email receipts. Select **Yes** to enable the functionality. Receipts are emailed to customers if the receipt is configured as an email receipt.
- **Translation Key For The Sender Name Of Emailed Receipts.** - Specify the translation key for the sender name of receipt emails. The value is specified in `translations_en.properties`.

## Gift Receipts

- **Allow User To Choose Gift Receipt Print Method?** - Determines whether the system allows the user to choose to print a gift receipt for each item or one gift receipt for all items.
  - Select **Yes** to allow the user to choose whether to print a gift receipt for each item or one gift receipt for all items.
  - Select **No** to not allow the user to choose a gift receipt type option.
- **Maximum Gift Receipts That Can Be Printed.** - Enter the maximum number of gift receipts allowed to be printed by the system before a manager override is required.
- **Print One Receipt Per Gift Item?** - Used when the quantity of a line item is greater than one. Determines whether the system prints a separate gift receipt for each item (Yes), or prints one gift receipt for the total quantity (No).
- **Prompt User To Group Gift Receipts?** - Determines if the associate is prompted to group items onto one or many gift receipts at the customer's discretion.

## Gift Registry

- **Automatically print gift receipts for items purchased from a gift registry?** - Determines whether the system automatically adds a gift receipt to an item purchased from a gift registry. Select **Yes** to have the gift receipt automatically added to an item purchased from a gift registry.

## Inventory Location Based

- **Print Inventory Location Sold From On Receipt?** - Determines whether the system prints the inventory location from which an item was sold on the receipt.

## Item Options

- **A List Of Non-Merchandise Item Types That Are Included In Item Count.** - Select the non-merchandise item types that will be included in the total item sold count on the sales receipt. Valid Values: Voucher, Loyalty Card.

## Kit Options

- **Link The Component Quantity Of A Kit To The Kit Quantity For Receipts?** - Determines whether the quantity of the kit component rows on the virtual and real receipts are linked to the quantity of the kit item.

- If **Yes**, the component item quantity displayed will be multiplied by the quantity of the parent kit line item.
- If **No**, the component item quantity will not change, regardless of the parent kit line item's quantity.
- **Maximum Number Of Kit Components To Display On A Receipt.** - Enter the maximum number of kit components to display on the virtual receipt for a kit item. If there are more kit components than rows available for display, the last row will be used to display a continuation string, such as an ellipsis (...).

## Layaway

- **Print Layaway Merchandise Ticket Per Item?** - Determines whether the system prints a separate merchandise ticket for each layaway item at setup.
- **Print Layaway Merchandise Ticket With All Items?** - Determines whether the system prints a merchandise ticket for a layaway account.
- **Print Layaway Specific Receipt?** - Determines whether the system prints a layaway receipt that contains only layaway account and item information. Line items belonging to other sale types (that is, sales or returns) will not be included on this receipt.

## Loyalty Options

- **Show Loyalty Card Expiration Date?** - Determines whether to show the loyalty card expiration date in the display and on the receipt.

## Send Sale

- **Print Merchandise Ticket For Send Sale Items?** - Determines whether the system prints a merchandise ticket for each send sale item sold.

## Till Account

- **Print Total Cash Pickup Amounts On Closing Till Receipts?** - Determines whether the system prints the total cash pickup amount on closing till count receipts.

## Training Mode

- **Restrict Printing Of Receipt Confirming Training Mode Enter And Exit?** - Determines whether the system prints receipts for entering and exiting training mode. (Training mode must be enabled on the register for this option to be valid.)
- **Restrict Receipt Printing In Training Mode?** - Determines whether the system prints receipts in training mode. (Training mode must be enabled on the register for this option to be valid.)

## Transaction Behavior

- **Print Store Copy Of Receipt When Sigcap Used?** - Determines whether the system prints a store copy sales receipt if the customer signature is captured by a signature capture device.
- **Print Suspended Transaction Receipt?** - Determines whether the system prints a receipt when suspending a retail transaction.

# Configuring Xstore Point-of-Service System Config Options

## Note:

This option replaces the standard process of manually managing the SysConfig.xml file. If you use this Oracle Retail Xstore Office configuration tool, SysConfig.xml files should not be created manually and installed in any store/register (via config path).

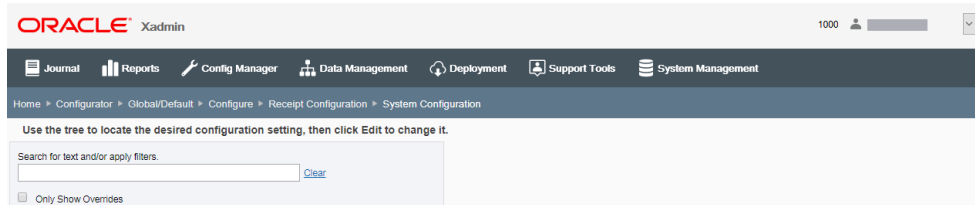
If any SysConfig.xml files are manually created and installed in any store/register (via config path), the changes they contain will work in Oracle Retail Xstore Point of Service as they always have; however, these configurations will be totally unknown to this System Config option and may possibly impair its ability to work properly.

...continued from step 4

## Using the System Config Search Feature

1. At the System Configuration page Search box, do one of the following:

**Figure 5-34 System Configuration Page - System Config Search Box**



- To find system configurations containing specific text, enter the search text in the input box, then press [Enter]. The text typed here can be found anywhere within the configuration: the label, the description, the module, or the config path itself. The results are shown in the left panel (folder tree). Only those configurations containing the specified text within the label, description, module, or config path are displayed. If needed, click Clear to remove the search criteria and return to the default System Configuration page.
- To view only system configuration categories and configuration options with overrides, select the Only Show Overrides check box.

## About Configuration Overrides

A configuration marked as an override differs between scopes:

- Within the Global scope, an override means that the state of the configuration varies from Oracle Retail Xstore Point of Service base configuration.

- Within a Profile Group/Profile Element combination, an override means that the configuration varies from the Global configuration.
  - To return to the default System Configuration page, deselect the check box.
  - To display additional filtering options, click **Show** more filters.Additional filter options display:

**Figure 5-35 Additional Filter Options**

Search for text and/or apply filters. [Clear](#)

Only Show Overrides

[Hide filters](#)

*Include configurations by tag.*

<input checked="" type="checkbox"/> Admin	<input checked="" type="checkbox"/> Loyalty	<a href="#">Include all</a>
<input checked="" type="checkbox"/> Airport	<input checked="" type="checkbox"/> Menu	<a href="#">Exclude all</a>
<input checked="" type="checkbox"/> Associate Tasks	<input checked="" type="checkbox"/> Receipts	
<input checked="" type="checkbox"/> CRM	<input checked="" type="checkbox"/> Register	
<input checked="" type="checkbox"/> Commission	<input checked="" type="checkbox"/> Return	
<input checked="" type="checkbox"/> Country Pack	<input checked="" type="checkbox"/> Sale	
<input checked="" type="checkbox"/> Discounts	<input checked="" type="checkbox"/> Scan Item or UPC	
<input checked="" type="checkbox"/> Fiscal	<input checked="" type="checkbox"/> Security	
<input checked="" type="checkbox"/> Human Resources	<input checked="" type="checkbox"/> Serial Number Exchange	
<input checked="" type="checkbox"/> Interface	<input checked="" type="checkbox"/> Store Specific	
<input checked="" type="checkbox"/> Inventory	<input checked="" type="checkbox"/> Taxes	
<input checked="" type="checkbox"/> Invoice	<input checked="" type="checkbox"/> Tender	
<input checked="" type="checkbox"/> Items	<input checked="" type="checkbox"/> Xenvironment	

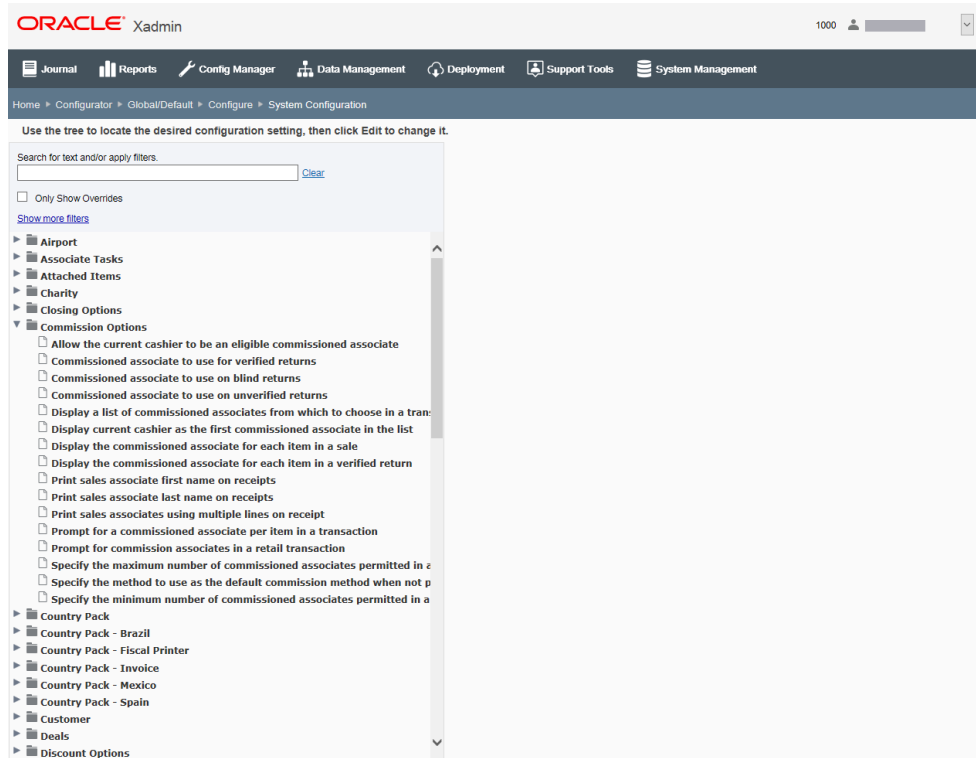
This option provides an extra level of organization for the various configuration options, and also provides the ability to filter on just one or many tags. By default, all tags are selected. Select one or more tags to view only the related category folders. To select all tags at once, click **Include all**. To clear all selected tags, click **Exclude all**. When finished with the filter options, click **Hide filters**.

- Continue with Viewing/Editing System Configurations. Continue with Viewing/Editing System Configurations. Continue with Viewing/Editing System Configurations.

## Viewing/Editing System Configurations

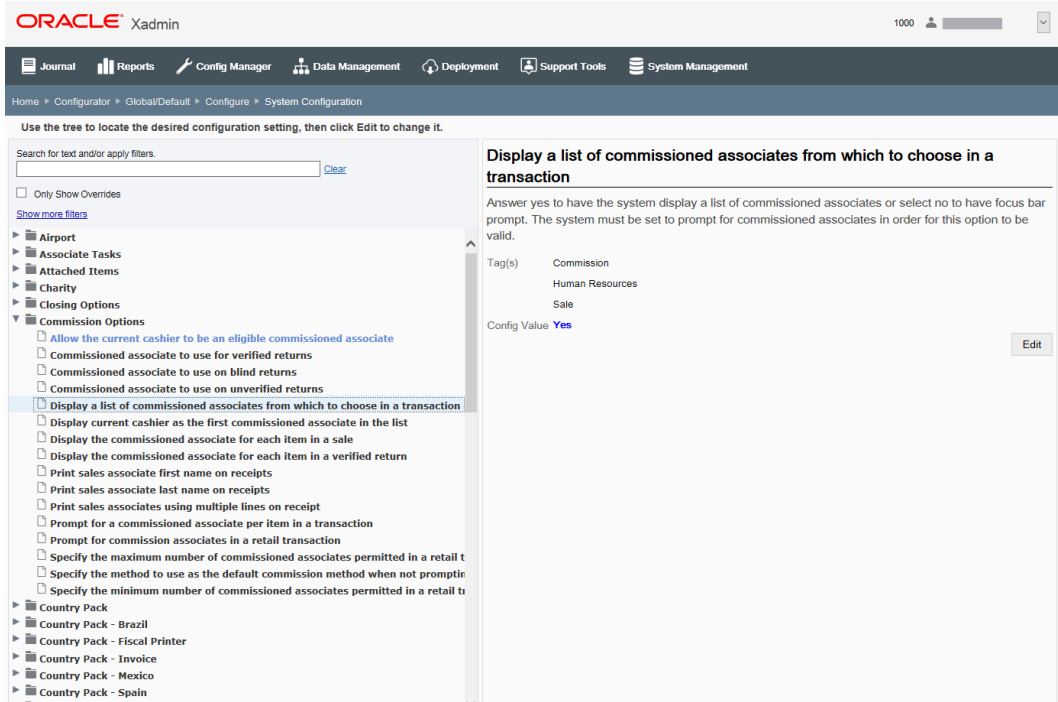
1. On the left side of the System Configuration page, click the arrow associated with a system configuration category to open the folder and show the configuration options within the selected category.

**Figure 5-36 System Configuration Page - Expanded Category Folder**



- If a category contains at least one configuration option that has been overridden, the color of the folder is blue.
  - The overridden configuration option within the category is indicated by an override icon.
  - See [About Configuration Overrides](#) for more information about configuration overrides.
2. Select a configuration option within the selected category to view the configuration details in the right side of the System Configuration page.

Figure 5-37 System Configuration Page - Configuration Option Detail



The following detailed information displays:

- The configuration name (label).
- The configuration description.
- The tag or tags associated with the selected configuration. This information can be used to filter or search for configurations.
- Valid values when applicable.
- Base Value or Global Value if the Configuration has been overridden. See Figure 5-38 below.
- The current value setting of the configuration.

 **Note:**

If this setting is different than its original value (Base for Global scope as shown here, and Global for configuration overrides) the original value is also shown in this section. See [About Configuration Overrides](#).



**Figure 5-38 Global Scope - Base Value Override**

**Specify the method to use as the default commission method when not prompting for commissioned associates**

This configuration only applies if prompting for commissioned associates is turned off. This determines who the default commissioned associate will be for retail transactions.

Tag(s)	Commission Human Resources
Valid Values	Current Cashier - The system will assign the commission for a transaction to the cashier currently logged in House Account - The system will assign all commissions to the account assigned to the entire store None - The system will not assign commissions
Base Value	Current Cashier - The system will assign the commission for a transaction to the cashier currently logged in
Override Value	<b>None - The system will not assign commissions</b>

- The path in SysConfig.xml (at the bottom of the page).

**Figure 5-39 Path SysConfig.xml**

[CommissionedAssociates---DefaultCommissionMethod](#)

3. Click **Edit** to make any changes.
4. At the editing window you have the following options:

**Figure 5-40 System Configuration - Edit Window**

**Specify the method to use as the default commission method when not prompting for commissioned associates**

This configuration only applies if prompting for commissioned associates is turned off. This determines who the default commissioned associate will be for retail transactions.

Tag(s)	Commission Human Resources
Config Value	<b>Current Cashier - The system will assign the commission for a transaction to the cashier currently logged in</b>

*Edit config*

Current Cashier - The system will assign the commission for a transaction to the cashier currently logged in  
 House Account - The system will assign all commissions to the account assigned to the entire store  
 None - The system will not assign commissions

Force to appear as override

[Revert to base value](#)

- **Edit Config** - Select an option or enter information as needed for the configuration.
- **Force to appear as override check box** - Select this option to label the configuration as an override.

Overrides differ between scopes. Within the Global scope, an override means that the state of the configuration varies from Oracle Retail Xstore Point-of-Service base configuration. Within the Profile Group/Profile Element combination scope, an override means that the configuration varies from the Global configuration.

This setting is more than an arbitrary flag. For example, if a Profile Group/ Profile Element is using the same config values as the global configuration, that means that when you change the config values for the global configuration, you are also effectively changing the config values for the profile group/profile element. Using this check box, config values marked as overrides for a Profile Group/Profile Element will not change.

- **Revert to base value1 or Revert to global value link** - Click this link to revert the configuration back to the base value (or global value for Profile Group/Profile Element combination scope).

Edit Form Navigation Options:

- To close the form without saving your changes, click the Close icon.
- To view the previous/next configurations in the category, click Previous/Next button.

5. Click **Save** to save your changes and return to the System Configuration Page.
6. After completing System Configuration setup, you can perform the following options:
  - To deploy your changes, see [Deploying Configuration Changes](#).
  - To view a summary list of a profile element's configuration changes to identify how it differs from the global configuration, see [Viewing Configuration Changes](#).
  - [CONFIGURATION OVERRIDES & STORE SPECIFIC OVERRIDES ONLY] - To delete the current profile element configuration changes, see [Delete Profile Configuration Overrides](#).
  - [STORE SPECIFIC OVERRIDES ONLY] - To copy store configurations from another store, see [Copy Store Configurations](#).

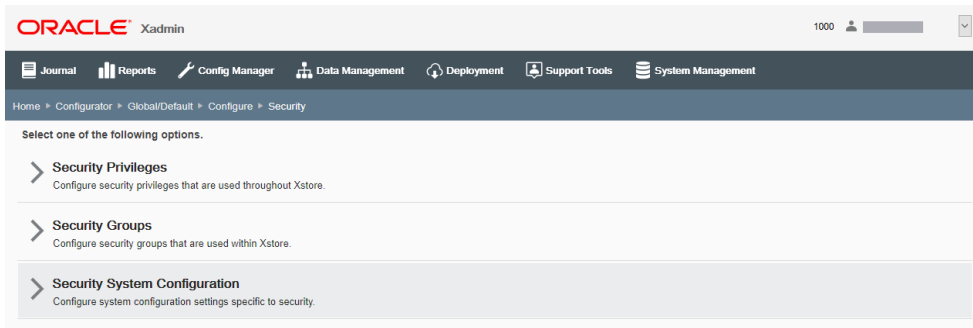
## Configuring Oracle Retail Xstore Point-of-Service Security

...continued from step 4

This option is only available for the Global scope.

1. Select an option from the Security Configuration page:

**Figure 5-41 Security Configuration Page Options**



- Select Security Privileges to set up Oracle Retail Xstore Point-of-Service security privileges. Continue with step 2 below.
  - Select Security Groups to add or edit existing Oracle Retail Xstore Point-of-Service security groups. Skip to [Security Groups Setup](#).  
Select Security System Configuration to configure system configuration settings specific to security. Skip to [Security System Configuration](#).
2. At the Security Privileges page, select a privilege to edit.

 **Note:**

To find a security privilege in the list, type any text that may be part of the privilege in the "Find a Privilege" text box at the top of the page.

3. Edit the Security Privilege as needed:

Figure 5-42 Edit Security Privilege Window

**Edit Privilege**  
**Add Coupon**

Is authentication required?       Is a second set of credentials required?

Can this privilege be overridden?

Security Groups	
<input checked="" type="checkbox"/>	Everyone
<input type="checkbox"/>	Trainee
<input type="checkbox"/>	Cashier
<input type="checkbox"/>	Keyholder
<input type="checkbox"/>	Manager

Save      Previous      Next

Edit Form Navigation Options:

- To close the form without saving your changes, click the close icon.
- To view the previous/next configurations in the category, click the Previous/Next button.
- **Is authentication required?** - Determines if the POS system should either always prompt for authentication, or authenticate against the current POS user. If selected, indicates that authentication is required for this privilege type.
- **Can this privilege be overridden?** - If selected, the privilege can be overridden.
- **Security Groups** - Select all groups that apply. For example:
  - Everyone
  - Trainee
  - Cashier
  - Keyholder
  - Manager
- **Is a second set of credentials required?** - Determines whether a second authorization is required.

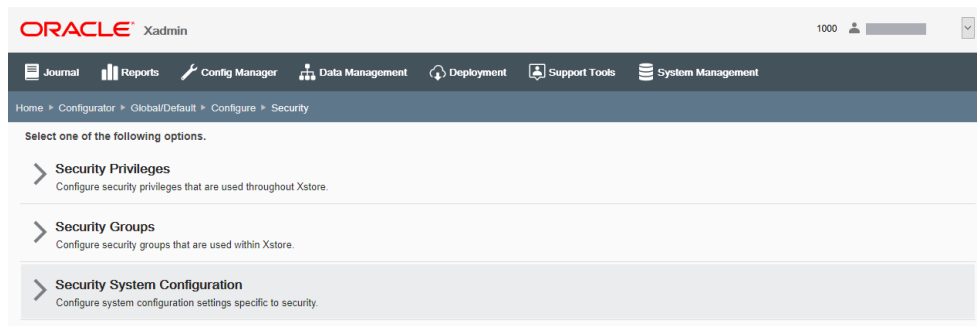
If selected, complete additional information as needed:

- **Do they have to be different than the first set?** - If selected, then the same Employee ID cannot be used in both prompts.
  - **Second Security Groups** - Select all groups that apply.
4. Click Save to return to the Security Configuration page.
  5. After completing Security Privilege setup, you can perform the following options:
    - To deploy your changes, see [Deploying Configuration Changes](#).
    - To view a summary list of a profile element's configuration changes to identify how it differs from the global configuration, see [Viewing Configuration Changes](#).

## Security Groups Setup

1. Select Security Groups from the Security Configuration page.

**Figure 5-43 Security Configuration Page Options**



2. You have the following options at the Security Groups Page:

**Figure 5-44 Security Groups Page**

Group ID	Description	Group Rank
TRAINEE	Trainee	0
MANAGER	Manager	0
KEYHOLDER	Keyholder	0
CASHIER	Cashier	0
EVERYONE	Everyone	0

- To add a new Security Group, click the **Add** a new security group link.
  - a. Enter the information in the Add Security Group window. All fields are required.

**Figure 5-45 Add Security Group Window**

- b. Click **Save**. The new group is added to the Security Groups list.
- To edit an existing Security Group, select it in the Security Groups list, then click **Edit**.
  - a. Enter the information in the Edit Security Group window. Only the rank can be changed.

**Figure 5-46 Edit Security Group Window**

- b. Click **Save**.
- 3. After completing Security Groups setup, you can perform the following options:
  - To deploy your changes, see [Deploying Configuration Changes](#).
  - To view a summary list of a profile element's configuration changes to identify how it differs from the global configuration, see [Viewing Configuration Changes](#).

## Security System Configuration

 **Note:**

The system configuration options for security in this feature are simply a subset of the system configuration options available from Oracle Retail Xstore Point-of-Service System Config Options. See [Configuring Xstore Point-of-Service System Config Options](#) for more information.

The following configurations apply specifically to security. The categories have been set up as follows:

- [House Accounts](#)
- [Sales](#)
- [Security](#)
- [Store Specific](#)
- [Tender Options](#)
- [Till Accountability](#)
- [Warranty](#)

## House Accounts

**Manager override when tender amount exceeds house account balance? -** Determines whether the system prompts for manager override if the tender amount exceeds the remaining balance of the house account. If Yes, and a manager-level user is logged in, the system displays the credit limit and prompts the user to proceed. If a user lower than the manager privilege is logged in, and the user chooses to proceed with exceeding the credit limit, the manager security login displays for approval.

## Sales

**Allow user to ring his/her own sale? -** Determines whether the system allows employees to ring retail transactions for themselves.

## Security

- **Account lockout allowable retry attempts. -** If Account Lockout functionality is enabled, the system locks out the associate's account after this number of failed login retries. Default: Enabled, set to 3 attempts.
- **Allowable retry attempts per challenge question. -** If Account Lockout functionality is enabled, the system locks out the associate's account after this number of failed challenge question retries.
- **Enable Lockout Feature For Failed Login Attempts? -** Turns on/off the Account Lockout functionality where the system locks out the associate's account after a configured number of failed login retries. Default: Enabled
- **Enable password expiration? -** Turns on/off Password Expiration functionality to expire an employee login password after a specified number of days. Default: Enabled
- **Identify the ID to use for employee logon -** Determines the type of identification the associates will use to log into the system; Employee ID or Login ID.
- **Login with employee card does not require password entry -** If enabled, the login to Xstore POS with an MSR-based employee card does not require entering a password. If disabled, the employee card will be used to provide the user ID, but password entry will be required to complete login.
- **Password expiration days. -** If Password Expiration functionality is enabled, the system expires an employee login password after this number of days. Default: 90 days

- **Password re-use restriction count.** - Associates are not allowed to reuse the same password within this number of password resets.
- **Specify the number of minutes to wait before unlocking the previously locked users.** - The system automatically unlocks the previously locked users after this number of minutes from their locked out time stamp.
- **The interval between attempts to unlock previously locked users.** - The interval, in seconds, between attempts to unlock previously locked users.
- **The number of challenge questions required for employee identification.** - This setting provides the ability to dictate how many challenge questions employees must answer before being allowed to reset their password.

 **Note:**

There are ten challenge questions stored within the database, therefore no more than ten questions can be asked.

- **Relate default user ID.** - The default user ID that has access to Oracle Retail Customer Engagement Cloud Services. This user ID must be set up in both Oracle Retail Xstore Point of Service and Oracle Retail Customer Engagement Cloud Services for WSDL version 2.
- **Relate user security type.** - Determines how user data security should be pulled from Oracle Retail Customer Engagement Cloud Services. This will tell whether the security is based on the individual user, the user's role, or a default user.
- **Treat security groups as 'Greater-Than' or 'Greater-Than Or Equal-To'.** - When creating/editing employees, this determines whether higher-ranked in `sec_groups.group_rank` means greater than or greater than or equal.
  - Answer **Yes** to allow a logged in user to edit associates with a rank that is equal to or lower than the logged in associate.
  - Answer **No** if the logged in user can only edit associates with a lower rank than themselves. If set to No, the highest ranking employee in the store will be unable to create or edit an employee of equal rank. In this scenario, the information must be downloaded from the home office rather than created in the store. (For example, if Manager is the highest rank in the store, new managers must be downloaded from the home office rather than created in the store).
- **Use challenge questions for employee password reset?** - Turning this setting on will enable the use of challenge questions to identify an employee for the purpose of resetting the employee's password.

 **Note:**

Once this is turned on, any employee that has yet to select and answer challenge questions will be forced to do so upon successfully logging into back office or register mode.



## Store Specific

- **Default the type of ID required for tenders requiring customer identification.** - The default identification type used for certain tenders that require customer identification information. Valid Values: Drivers License, Social Security, Military Id, Credit Card, Employee Id, Customer Card, Any identification type
- **Hide menu options from users that do not have appropriate security levels?** - This is used to hide menu options the user does not have security privileges to use. Answer yes to hide the menu option completely. Answer no to display the option as disabled.

## Tender Options

- **Authorization method code for BinSmart lookups for Merchant Warehouse.** - This is the authorization method code used to perform the lookup. Valid only for Merchant Warehouse.
- **Display rounded cash total?** - Only applicable for currency rounding, this indicates whether the rounded cash total is displayed below the transaction total in the viewport.
- **Enable merchant Warehouse's BinSmart lookups?** - This determines whether Merchant Warehouse's BinSmart lookups are used for Credit/Debit authorizations.
- **Export hashed account number?** - Determines whether or not to include the hashed account number in PosLog.xml.
- **Inform users with a message that no signature is required?** - This option controls turning off/on the information message displayed when processing a transaction below a configured value.
- **Preferred payment recommendation when errors occur.** - This is the preferred payment recommendation when an error occurs or a failed response is returned; credit or debit.
- **Require pin pad entry for debit tender?** - Determines whether a pin pad device is required for tendering with a debit card.
- **Specify the rounding method to use for local currency.** - The local currency amount rounding method.
  - Half Up - Round to the nearest neighbor unless equidistant, then round up.
  - Half Down - Round to the nearest neighbor unless equidistant, then round down.
  - Half Even - Round to the nearest neighbor unless equidistant, then round to even neighbor. Example: 2.5 rounds to 2 while 3.5 rounds to 4.
  - Ceiling - Round toward positive infinity. This is the opposite of FLOOR and never decreases the calculated value.
  - Down - Round to the next digit; closer to zero.
  - Floor - Round down toward negative infinity. This is the opposite of CEILING and never increases the calculated value
  - Up - Round to the next digit; away from zero.
  - Unnecessary - Rounding is not necessary.

## Till Accountability

- **Adjust store bank balance by deposit discrepancies?** - Determines whether the system automatically adjusts the store bank balance based on the bank deposit discrepancy.
- **Count method used for cash pickup** - The cash count entry method for a cash pickup.
- **Count method used for opening store bank** - The cash count entry method used for counting the store bank.
- **Count method used for store bank deposit** - The store bank deposit till count method. This configuration is only valid if the store requires an end count of the store bank at store close.
- **Count method used for opening a till** - The cash count entry method for a till opening count.
- **Count method used for store bank** - The cash count entry method for a store bank deposit.
- **Display count balance info on till close count?** - Determines whether the system displays the till count balance and discrepancy information after the associate completes the till close count.
- **Display options for cash pickup summary.** - The cash pickup count summary screen display type.
  - Minimum - Declared amount
  - Simple - Declared amount, system amount
  - Detailed - Declared amount, system amount, over/under amount
  - Full - Currently, same as Detailed
- **Display options for mid-day deposit till count summary.** - The mid-day deposit till count summary screen display type.
  - Minimum - Declared amount
  - Simple - Declared amount, system amount
  - Detailed - Declared amount, system amount, over/under amount
  - Full - Currently, same as Detailed
- **Display options for till end count summary.** - The till end count summary screen display type.
  - Minimum - Declared amount
  - Simple - Declared amount, system amount
  - Detailed - Declared amount, system amount, over/under amount
  - Full - Currently, same as Detailed
- **Display options for till reconciliation summary.** - The till reconcile count summary screen display type.
  - Minimum - Declared amount
  - Simple - Declared amount, system amount
  - Detailed - Declared amount, system amount, over/under amount

- Full - Currently, same as Detailed
- **Display options for till start count.** - The cash count entry method used for the start count.
  - Minimum - Declared amount
  - Simple - Declared amount, system amount
  - Detailed - Declared amount, system amount, over/under amount
  - Full - Currently, same as Detailed
- **Force re-count of till with discrepancies over threshold?** - Determines whether the system forces a till recount if the till close count discrepancy exceeds the threshold.
- **Method Of Counting Cash Deposit.** - The cash count entry method for a store bank deposit.
  - Total Short - User enters total cash amount only.
  - Denomination - User enters denominated cash amounts.
- **Method Of Counting For Start Till.** - The cash count entry method for a till opening count.
  - Total Short - User enters total cash amount only.
  - Denomination - User enters denominated cash amounts.
- **Method Of Counting For Store Bank Opening.** - The cash count entry method used for counting the store bank.
  - Total Short - User enters total cash amount only.
  - Denomination - User enters denominated cash amounts.
- **Method Of Counting For Till Cash Transfer.** - The cash count entry method for a cash transfer.
  - Total Short - User enters total cash amount only.
  - Denomination - User enters denominated cash amounts.
- **Method Of Counting For Till Pickup.** - The cash count entry method for a cash pickup.
  - Total Short - User enters total cash amount only.
  - Denomination - User enters denominated cash amounts.
- **Method To Count Store Bank Deposit.** - The store bank deposit till count method. This configuration is only valid if the store requires an end count of the store bank at store close.
  - Storebank Complete - Brings up the entire store bank end count screen for all tenders.
  - Remaining Cash - Prompt the user to enter the total cash NOT to be deposited to the bank institution.
  - Complete Deposit - Deposit all tenders from the store bank to the bank institution.
- **Notify at end of a transaction when cash in drawer is below this threshold.** - When the cash amount in the drawer drops below this amount after a retail

transaction is completed, an acknowledge-only prompt will appear and notify the user.

- **Print total cash pickup amounts on closing till receipts?** - Determines whether the system prints the total cash pickup amount on closing till count receipts.
- **Prompt user to open store bank during store open?** - Determines whether the system automatically prompts the user asking if they wish to open the store bank when the store is opened.
- **Require store bank deposit count at close?** - Determines whether the system requires a store bank deposit count at store close.
- **Skip initial count summary** - When initiating a count, determines whether the system displays the tender summary list or the first tender to be counted.
- **Threshold amount used for suggested cash pickup.** - When the cash amount exceeds this configured maximum amount, the system will prompt the associate to perform a cash pickup with the amount that is the current cash total minus this amount. This is a positive floating point number indicating the minimum amount of cash that should be left in the till following a pickup.
- **Validate cash refund amounts against the current till count?** - Determines whether the system validates refund cash amounts to ensure the current till cash amount is greater than the refund cash amount.
- **Validate store bank deposit amount against system?** - Determines whether the system validates the store bank deposit amount and prompts the associate to accept or recount if there is any discrepancy.

## Warranty

- **Allow warranties not on file?** - Per each context (return or work order), when enabled, the system will allow the user to apply existing warranties that cannot be verified (given appropriate security clearance). When disabled, the application of unverifiable warranties will always be prohibited. Valid Values: Return, Work Order

## Configuring Tenders

### Note:

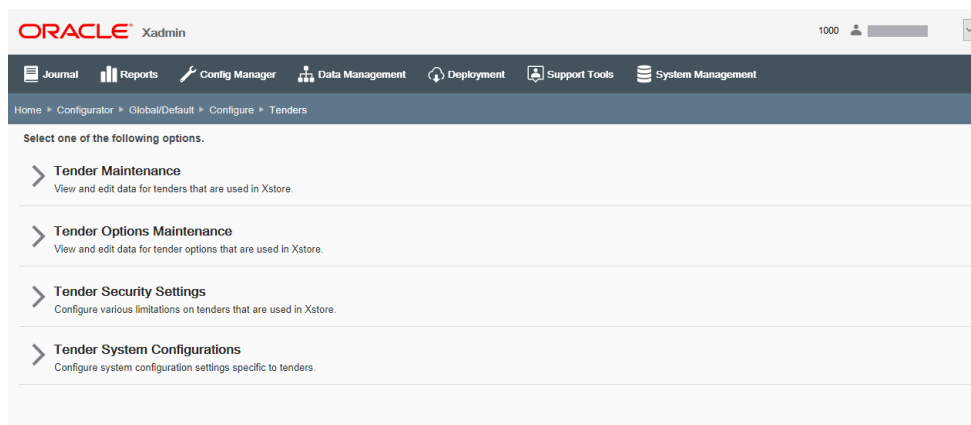
Only tenders of type Miscellaneous, Currency, and Credit Card can be created through Oracle Retail Xstore Office. Tender type codes (tnd\_tndr\_typcode) must be pre-defined in the Xcenter (part of Oracle Retail Xstore Office) database to create tenders.

Base Oracle Retail Xstore Point of Service only supports USD (US Dollar), CAD (Canadian Dollar), EUR (Euro), GBP (British Pound), and JPY (Japanese Yen) without additional Oracle Retail Xstore Point of Service changes. If support for other currencies is required, contact your Oracle representative for more information.

...continued from step 4

1. Select an option from the Tender Configuration page:

Figure 5-47 Tender Configuration Page Options



- Select **Tender Maintenance** to view and edit data for tenders that are used in Oracle Retail Xstore Point of Service. Continue with step 2 below.

 **Note:**

The Tender Maintenance option is only available at the global level.

- Select **Tender Options Maintenance** to view and edit data for tender options that are used in Oracle Retail Xstore Point of Service. Skip to Tender Options Maintenance.
  - Select **Tender Security Settings** to configure tender limitations in Oracle Retail Xstore Point of Service. Skip to Tender Security Settings.
  - Select **Tender System Configurations** to configure the system configuration settings that apply specifically to tenders. Skip to Tender Configuration: System Configuration Options.
2. Select a Tender Type from the list, then click **Next**.
  3. At the Tender Maintenance page, add a new tender or edit an existing tender:

Figure 5-48 Tender Maintenance Page - Currency Example

The screenshot shows the Oracle Xadmin interface with the breadcrumb trail 'Home > Configurator > Global/Default > Configure > Tenders > Currency'. Below the breadcrumb, there is a heading 'Tender Maintenance' and an 'Add New' button. A table displays the following data:

Tender ID	Description	Currency	Status
EUR_CURRENCY	Euro Cash	EUR (Euro)	
USD_CURRENCY	Cash	USD (US Dollar)	
CAD_CURRENCY	Canada Cash	CAD (Canadian Dollar)	
AUD_CURRENCY	Australian Cash	AUD (Australian Dollar)	
BRL_CURRENCY	Brazilian Cash	BRL (Brazilian Real)	
GBP_CURRENCY	British Pound	GBP (British Pound Sterling)	
MXN_CURRENCY	Mexico Cash	MXN (Mexican Peso)	
PLN_CURRENCY	Polish Cash	PLN (Polish Zloty)	
SEK_CURRENCY	Sweden Cash	SEK (Swedish Krona)	

If adding a new tender:

- a. Click **Add New**.

 **Note:**

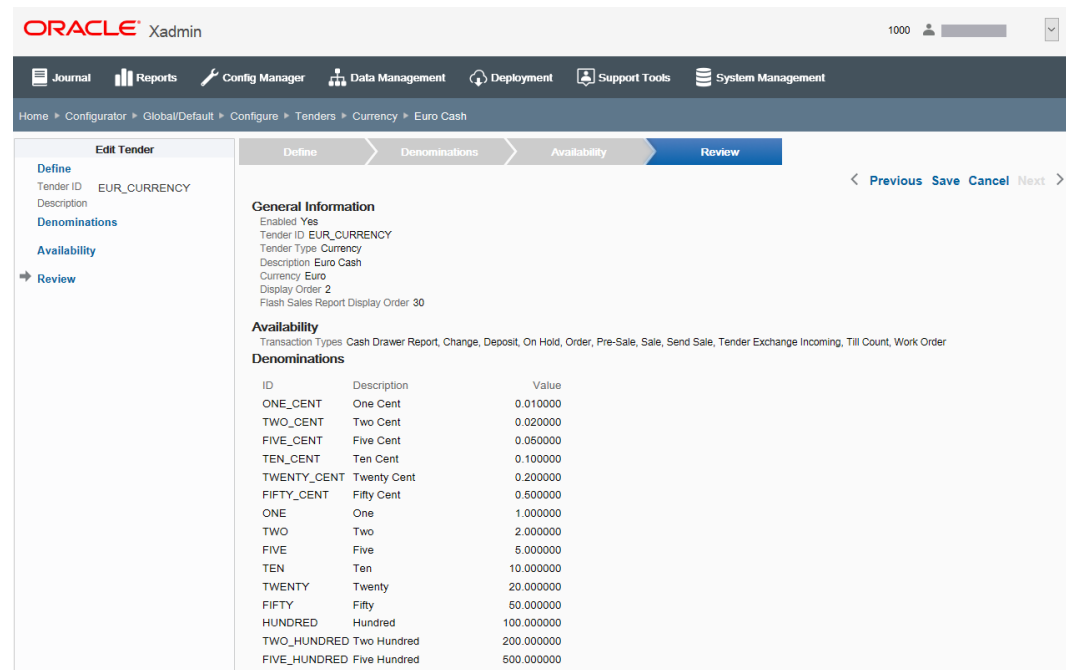
Only tenders of type Miscellaneous, Currency, and Credit Card can be created through Oracle Retail Xstore Office.

- b. Complete the fields as required, then click **Next**. See [Tender Configurations](#) for a list of tender configuration options.
- c. Skip to step 4 on page 54 to review your selections.

If editing an existing tender:

- a. Select the tender in the list.
  - b. At the Tender Detail window, click **Edit**.
  - c. Complete the fields as required, then click **Next**. See [Tender Configurations](#) for a list of tender configuration options.
  - d. Continue with step 4 below to review your selections.
4. Review the tender information you selected:

**Figure 5-49 Tender Information Review**



The screenshot shows the Oracle Xadmin interface for editing a tender. The breadcrumb trail is: Home > Configurator > Global/Default > Configure > Tenders > Currency > Euro Cash. The 'Edit Tender' window has four tabs: Define, Denominations, Availability, and Review. The 'Review' tab is selected, showing the following information:

**General Information**

- Enabled: Yes
- Tender ID: EUR\_CURRENCY
- Tender Type: Currency
- Description: Euro Cash
- Currency: Euro
- Display Order: 2
- Flash Sales Report Display Order: 30

**Availability**

Transaction Types: Cash Drawer Report, Change, Deposit, On Hold, Order, Pre-Sale, Sale, Send Sale, Tender Exchange Incoming, Till Count, Work Order

**Denominations**

ID	Description	Value
ONE_CENT	One Cent	0.010000
TWO_CENT	Two Cent	0.020000
FIVE_CENT	Five Cent	0.050000
TEN_CENT	Ten Cent	0.100000
TWENTY_CENT	Twenty Cent	0.200000
FIFTY_CENT	Fifty Cent	0.500000
ONE	One	1.000000
TWO	Two	2.000000
FIVE	Five	5.000000
TEN	Ten	10.000000
TWENTY	Twenty	20.000000
FIFTY	Fifty	50.000000
HUNDRED	Hundred	100.000000
TWO_HUNDRED	Two Hundred	200.000000
FIVE_HUNDRED	Five Hundred	500.000000

- To save the tender, click **Save**. The tender is added to the Tender list.
- To edit the tender:
  - Click **Previous** to go back one page, or select a configuration option in the Edit Tender section in the left panel of the window.

After making your changes, click **Save**. The new tender is added to the Tender list.

- To discard the tender changes, click cancel. When prompted, click **Yes** to confirm you want to cancel tender setup.
5. After completing tender setup, Oracle Retail Xstore Office returns to the Tender Maintenance page.
- To deploy your changes, see [Deploying Configuration Changes](#).
  - To view a summary list of a profile element's configuration changes to identify how it differs from the global configuration, see [Viewing Configuration Changes](#).
  - [CONFIGURATION OVERRIDES & STORE SPECIFIC OVERRIDES ONLY] - To delete the current profile element configuration changes, see [Delete Profile Configuration Overrides](#).
  - [STORE SPECIFIC OVERRIDES ONLY] - To copy store configurations from another store, see [Copy Store Configurations](#)

## Tender Configurations

This section describes the available tender configurations.

### Basic Information

Define the basic information for the tender, then click Next.

- **Tender ID** - Enter the tender identifier. This value can only be edited in Add mode.
- **Description** - Enter a text description of the tender.
- **Locale** - If needed, select a translation locale and enter the description for the locale.
- **Currency** - Set up the Currency ID:

#### Note:

This option allows you to set the Currency ID on any tender to a keyword "\*" that represents the local currency. For any tenders that have this keyword "\*" set as the currency ID, Oracle Retail Xstore Point of Service will retrieve the local currency ID from SysConfig.xml

This makes it easier to set up tender types to always use the local currency of the store rather than needing to explicitly define each tender with a specific currency ID.

For example, rather than setting up Visa/USD, Visa/CAD, Visa/AUD, and so on., it is possible to simply use the "\*" keyword for the Visa tender to instruct Oracle Retail Xstore Point of Service to retrieve the store's local currency ID automatically for Visa.

- To set the Currency ID to Xstore's local currency, disable the "Does this tender use a specific Currency?" check box. This automatically sets the currency ID

to "\*" . In Oracle Retail Xstore Point of Service, this "\*" value is recognized as a directive to use the local currency for the tender.

- To set the Currency ID to a specific value, enable the "Does this tender use a specific Currency?" check box. When prompted, select a Currency ID from the list of available currencies. Oracle Retail Xstore Point of Service will use the selected Currency ID for the tender.
- **Include in Flash Sales Report?** - If selected, the tender will be included on the Flash Sales Report. When prompted enter the order in which it should appear on the report in the Flash Sales Report Display Order field.
- **Display Order** - Determines the order in which tenders display on the count page during closing.
- **Enabled check box** - When selected, the tender is available for use.

## Denominations Information [DENOMINATION Tender Types Only]

Configure denominations for the tender.

**Figure 5-50 Denomination Information Tab**

Define **Denominations** Availability Review

< Previous Save Cancel Next >

These options are used to configure denominations for the tender.

Denomination ID

Description

Value  [Add Denomination](#)

ID	Description	Value
ONE_CENT	One Cent	0.010000 <a href="#">Delete</a>
TWO_CENT	Two Cent	0.020000 <a href="#">Delete</a>
FIVE_CENT	Five Cent	0.050000 <a href="#">Delete</a>
TEN_CENT	Ten Cent	0.100000 <a href="#">Delete</a>
TWENTY_CENT	Twenty Cent	0.200000 <a href="#">Delete</a>
FIFTY_CENT	Fifty Cent	0.500000 <a href="#">Delete</a>
ONE	One	1.000000 <a href="#">Delete</a>
TWO	Two	2.000000 <a href="#">Delete</a>
FIVE	Five	5.000000 <a href="#">Delete</a>
TEN	Ten	10.000000 <a href="#">Delete</a>
TWENTY	Twenty	20.000000 <a href="#">Delete</a>
FIFTY	Fifty	50.000000 <a href="#">Delete</a>
HUNDRED	Hundred	100.000000 <a href="#">Delete</a>
TWO_HUNDRED	Two Hundred	200.000000 <a href="#">Delete</a>
FIVE_HUNDRED	Five Hundred	500.000000 <a href="#">Delete</a>

- To add a new denomination, enter the following denomination detail, then click **Add Denomination**:
  - Denomination ID - The denomination identifier.
  - Description - The denomination description
  - Value - The denomination value



 **Note:**

A Delete option is available after adding a denomination.

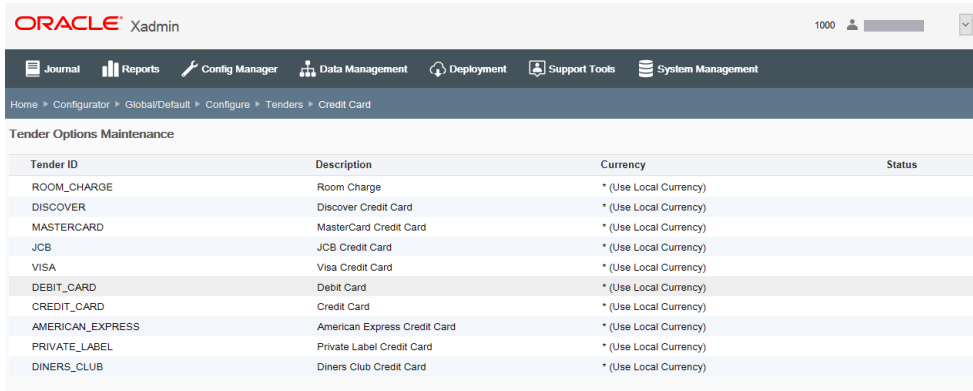
## Availability Information

Select the transaction types this tender is available for. To quickly choose all transaction types at once, click **Select All**.

## Tender Options Maintenance

1. Select Tender Options Maintenance from the Tender Configuration page (Figure 5-47).
2. Select a Tender Type from the list, then click **Next**.
3. At the Tender Options Maintenance page, select a tender from the list.

**Figure 5-51 Tender Options Maintenance Page**



Tender ID	Description	Currency	Status
ROOM_CHARGE	Room Charge	*(Use Local Currency)	
DISCOVER	Discover Credit Card	*(Use Local Currency)	
MASTERCARD	MasterCard Credit Card	*(Use Local Currency)	
JCB	JCB Credit Card	*(Use Local Currency)	
VISA	Visa Credit Card	*(Use Local Currency)	
DEBIT_CARD	Debit Card	*(Use Local Currency)	
CREDIT_CARD	Credit Card	*(Use Local Currency)	
AMERICAN_EXPRESS	American Express Credit Card	*(Use Local Currency)	
PRIVATE_LABEL	Private Label Credit Card	*(Use Local Currency)	
DINERS_CLUB	Diners Club Credit Card	*(Use Local Currency)	

4. At the Tender Options Detail window, click **Edit**.

Figure 5-52 Tender Options Detail Window

**DISCOVER - Discover Credit Card** Edit

**Usage**

- Effective Date *N/A*
- Expiration Date *N/A*
- Default to amount due **Yes**
- Allow overrides on failed over tendering **No**
- Cash Change Limit **\$999,999.00**
- Change Tender ID **Local Currency**
- Allow Split Tender **Yes**
- Serial Number Required **Yes**
- Cash Drawer Open **No**
- Cash Drawer Open on Post Void **No**
- Cash Drawer Assign **No**
- Cash Drawer Assign on Post Void **No**
- Endorsement Required **No**
- Minimum Denomination Amount **\$0.01**
- Rounding Mode *N/A*
- Voidable **Yes**
- Allow Change Back When Used as Foreign Currency *N/A*
- Fiscal Tender ID *N/A*

**Customer**

- Customer ID Type Required *N/A*
- Customer Required **No**

Previous Next

5. Complete the fields as required, then click **Next**. See [Tender Options Configuration](#) for a list of configuration options.
6. Review your selections and skip to step 4 on page 54 to complete tender options setup.

## Tender Options Configuration

This section describes the tender options.

### Usage Information

Define how the tender will be used.

- **Effective Date** - [OPTIONAL] Enter the effective date. Allows entry using the calendar component.
- **Expiration Date** - [OPTIONAL] Enter the expiration date. Allows entry using the calendar component.
- **Does this tender default the tender amount to the amount due?** - If selected, the amount due from the customer is shown as a default value in the focus bar at tendering.
- **Is a failed over tendering attempt allowed to be overridden for this tender?** - If selected, the over tender limit can be overridden.
- **Is there a limit to the amount of cash change?** - If selected, enter the maximum amount of cash that can be given as change when this tender is used as payment.
  - **Is there a required tender to give as change when the cash change limit has been exceeded?** - If selected, choose the tender to be used as change after the cash change limit has been reached.

- **Are split tenders allowed?** - When selected (default), this tender can be used if there are tenders in the current transaction. If this option is not selected, the tender amount entered cannot be less than what is due on the transaction.
- **Is a serial number required?** - If selected, the serial number of the tender type must be captured as part of the tender process.
- **Open cash drawer?** - If selected, the cash drawer opens when the tender type is offered by the customer.
- **Open cash drawer on Post Void?** - If selected, open the cash drawer each time a post void is performed using this tender.
- **Assign cash drawer?** (Networked cash drawers only)
- **Assign cash drawer on Post Void?** (Networked cash drawers only)
- **Is endorsement/franking required?** - If selected, an endorsement or franking is required before this tender can be accepted.
- **Is this tender able to be voided?** - If selected, this tender can be voided.
- **Is there a minimum denomination amount used for currency rounding for this tender?** - If selected, enter the minimum denomination value when prompted.
- **When used as foreign currency, is change allowed back on this tender?** - If selected, giving change in foreign cash currency is allowed. If not selected, any change due is given in the local currency.
- **Is there a required fiscal tender ID?**

## Customer Information

Define how the customer will use the tender.

- **Is customer identification required?** - If selected, choose the type of customer identification required.
- **Is customer association required?** - If selected, a customer must be associated with this tender.
- **Is customer signature required?** - If selected, a customer signature is required before this tender can be accepted.
- **Are there a minimum and maximum days for a return with this tender?** - If selected, enter the minimum number of days and maximum number of days allowed for return of an item to use this tender for refund.

## Authorization Information [AUTH tender types only]

Configure authorization rules for the tender.

- **Is a swipe on a magnetic stripe reader (MSR) required?** - If selected, the tender must be inserted into the magnetic card reader.
- **Is authorization required?** - If selected, authorization is required before the tender can be accepted.

Enter/select authorization information when prompted:

- **Authorization Method** - Select the authorization method from the list.
- **Is postal code entry required?** - If selected, a postal code must be associated with this tender.

- **Is expiration date entry required?** - If selected, this type of tender requires an authorization expiration date and it must be recorded at the time of settlement. (Used to enable expiration date prompting for a major credit tender.)
- **Is CID entry required when swiped?** - If selected, the card ID is required when this card is swiped.
- **Is CID entry required when keyed?** - If selected, the card ID is required when this card is keyed into the system manually.
- **Is PIN entry required?** - If selected, the customer must enter a personal identification number (PIN) to validate the method of payment.

## Count Information [COUNT Tender Types Only]

Specify the options used to configure counting and reporting rules for the tender.

- **Is this tender counted independently from tender type?** - If selected, the tender will be counted separately. When prompted, choose the Till Count Method to be used from the list. If not selected, the tender will be counted as part of its tender category grouping.

 **Note:**

This option is automatically selected for cash currency and cannot be deselected.

- **Is a recount required if tender does not balance?** - If selected, enter the Close Count Discrepancy Threshold value when prompted.
- **Reporting Group** - Select the reporting group for the tender:
  - Tender Summary group
  - Foreign Currency group
- **Is a suggested deposit amount required?** - If selected, enter the Suggested Deposit Threshold value when prompted.
- **Are the counts and amounts pre-populated?** - If selected, the system counts the tender automatically to populate the system tender.

## Tender Security Settings

 **Note:**

The combination of Tender ID, Security Group, Usage Code, and Entry Method must be unique.

1. Select **Tender Security Settings** from the Tender Configuration page (see Figure 5-42).
2. At the Tender Security Settings page, you can add a new security setting or edit an existing one.

Figure 5-53 Tender Security Settings Page

Tender	Security Group	Usage Code	Entry Method Code
Account Credit	Cashier	Sale	Default
Account Credit	Manager	Default	Default
Account Credit	Cashier	Default	Default
Account Credit	Manager	Sale	Default
American Express Credit Card	Cashier	Sale	Default
American Express Credit Card	Cashier	Return (with receipt)	Default
American Express Credit Card	Everyone	Signature Required	Default
American Express Credit Card	Manager	Return (with receipt)	Default
American Express Credit Card	Cashier	Default	Default
American Express Credit Card	Everyone	Signature Required for Return	Default
American Express Credit Card	Manager	Default	Default
American Express Credit Card	Manager	Signature Required for Return	Default
American Express Credit Card	Manager	Sale	Default
American Express Credit Card	Cashier	Signature Required for Return	Default
Australian Cash	Cashier	Default	Default
Australian Cash	Manager	Default	Default
Australian Cash	Cashier	Sale	Default
Australian Cash	Manager	Sale	Default
Brazilian Cash	Manager	Sale	Default
Brazilian Cash	Cashier	Default	Default

**Note:**

Use the Tender ID and Security Group filters to locate a tender/ security group in the list.

If adding a new tender security setting:

- a. Click **Add New**.
- b. At the Security Setting Detail window, complete the fields as required, then click **Save**. See [Tender Security Settings Configuration Options](#) for a list of configuration options.

If editing an existing tender security setting:

- a. Select the tender security setting in the list.
  - b. At the Security Setting Detail window, complete the fields as required, then click **Save**. See [Tender Security Settings Configuration Options](#) for a list of tender configuration options.
3. After completing tender security setting setup, Oracle Retail Xstore Office returns to the Tender Security Settings list page.
    - To deploy your changes, see [Deploying Configuration Changes](#).
    - To view a summary list of a profile element's configuration changes to identify how it differs from the global configuration, see [Viewing Configuration Changes](#).
    - [CONFIGURATION OVERRIDES & STORE SPECIFIC OVERRIDES ONLY] - To delete the current profile element configuration changes, see [Delete Profile Configuration Overrides](#).

- [STORE SPECIFIC OVERRIDES ONLY] - To copy store configurations from another store, see [Copy Store Configurations](#).

## Tender Security Settings Configuration Options

The available configuration options depend upon the selected Tender and Usage Code.

### General Information



#### Note:

The following fields cannot be changed in edit mode.

- **Tender ID** - Select the tender identifier from the list.
- **Security Group** - Select the security group from the list.
- **Usage Code** - Select the usage code from the list.
- **Entry Method Code** - Select the entry method code from the list.

### Limits

- **Maximum amount allowed to over tender** - Enter the maximum amount allowed to over tender.
- **Minimum amount Accepted** - Enter the minimum amount that can be accepted.
- **Maximum amount Accepted** - Enter the maximum amount that can be accepted.

### Online Authorization Rules

[only shown for tenders that require authorization]

- **Authorization needed when amount is above** - Enter the maximum value that can be accepted without authorization.
- **Maximum amount allowed to authorize** - Enter the maximum value of an individual tender type that can be authorized either in-house or by a third party. This especially applies to checks where the check authorization company sets a ceiling by retailer.

### Offline Authorization Rules

[only shown for tenders that require authorization]

- **Authorization needed when amount is above** - Enter the maximum value that can be accepted without authorization when in offline mode.
- **Maximum amount allowed to authorize** - Enter the maximum value of an individual tender that the system accepts without authorization when in offline mode.

### Refund

- **Maximum refund allowed with a receipt** - Enter the maximum refund allowed with a receipt.

- **Maximum refund allowed without a receipt** - Enter the maximum refund allowed without a receipt.

## Tender Configuration: System Configuration Options

### Note:

The system configuration options for tenders in this feature are simply a subset of the system configuration options available from Oracle Retail Xstore Point-of-Service System Config Options. See [Configuring Xstore Point-of-Service System Config Options](#) for more information.

The following configurations apply specifically to tenders. The categories have been set up as follows:

- Charity
- Closing Options
- Discount Options
- House Accounts
- Opening Options
- Returns
- Store Specific
- Tender
- Tender Options
- Till Accountability

### Charity

- **Enable Prompting User When Voiding Charity Line Item?** - Determines whether the system displays the notification message when a charity item is voided if tendering is canceled.

### Closing Options

- **Perform Till Count During Close?** - Determines whether the system prompts the associates to perform a till closing count at register close.

### Discount Options

- Define the rounding method used for the application of discounts - How Should Price Be Rounded After Discount Applied? Select the local currency amount
  - Half Up - Round to the nearest neighbor unless equidistant, then round up.
  - Half Down - Round to the nearest neighbor unless equidistant, then round down.

- Half Even - Round to the nearest neighbor unless equidistant, then round to even neighbor. Example: 2.5 rounds to 2 while 3.5 rounds to 4.
- Ceiling - Round toward positive infinity. Note: This is the opposite of FLOOR and never decreases the calculated value.
- Down - Round to the next digit; closer to zero.
- Floor - Round down toward negative infinity. Note: This is the opposite of CEILING and never increases the calculated value.
- Up - Round to the next digit; away from zero.
- Unnecessary - Rounding is not necessary.
- Tender rounding as transaction discount - Determines whether or not the system allows applying a discount/markup for tender rounding.

## House Accounts

- **Manager Override When Tender Amount Exceeds House Account Balance?** - Determines whether the system prompts for manager override if the tender amount exceeds the remaining balance of the house account.
  - If set to **Yes**, and a manager-level user is logged in, the system displays the credit limit and prompts the user to proceed.
  - If set to **Yes**, and a user lower than the manager privilege is logged in, and the user chooses to proceed with exceeding the credit limit, the manager security login displays for approval.
  - If set to **No**, the system does not prompt for manager override.
- Prompt for user information on house account transaction. - Determines whether or not the system prompts for the account user information on any activity for House Accounts.
- Require the customer to be a House Account owner. -Determines whether or not the system requires the customer of the retail transaction to be the House Account owner in order to access House Account functionality (tender, payment).
- Specify the amount allowed to over tender the House Account tender over the credit limit. - The threshold amount the system allows when the House Account tender amount exceeds the account credit limit.
- Specify the phone number to call for manual authorization of a House Account tender over the credit limit. -The phone number for the associates to call for authorization when the House Account tender amount exceeds the account credit limit and the exceeded amount is below the threshold amount.

## Opening Options

- Bypass Till Counts on Registers without Cash Drawers - This applies to Register Accountability Only. Used for registers that do not have a cash drawer or do not handle cash. Select Yes to prevent the system from prompting for begin or end count during the register open or close. The system automatically moves all tender amounts from the register/handheld to the store bank. This applies to Register Accountability Only. Used for registers that do not have a cash drawer or do not handle cash. Answer Yes to prevent the system from prompting for begin or end count during the register open or close. The system automatically moves all tender amounts from the register to the store safe.



## Returns

- **Prompt For Tender On Credit Card Returns?** - Determines whether the system prompts for refund tender amount to be credited back to the original sale credit card.
  - If **Yes**, the system prompts for the amount to credit back to the original card.
  - If **No**, the entire refund amount will be credited back to the selected original credit card.

## Store Specific

- Default the type of ID for tenders requiring customer identification. - Select the default identification type used for certain tenders that require customer identification information. Valid Values: Drivers License, Social Security, Military ID, Credit Card, Employee ID, Customer Card, Any identification type.

## Tender

- Allow multiple incoming tenders in one transaction. - Determines whether the system allows multiple incoming (exchange from) tenders in a tender exchange transaction.
- Allow multiple outgoing tenders in one transaction. - Determines whether the system allows multiple outgoing (exchange to) tenders in a tender exchange transaction.
- Default tender ID to use for change if not specifically configured. - Select the change tender ID the system will use by default if the system cannot find the valid change tender based on the sale tenders. Valid Values: Issue Store Credit, Issue Gift Card.
- Prompt user to imprint credit card for manual cards. - Determines whether the system prompts the associate to imprint the credit card when there is a manually entered credit card tender in the completed sale transaction.
- Minimum denomination increment value for quick cash buttons. . - The Quick Cash Buttons will display in increments based on this entry for the minimum denomination factor.
- Enable Quick Cash Buttons - Determines whether the Quick Cash Button functionality is enabled.

## Tender Options

- Define the threshold for cash tender to invoke additional information collection. - If the amount of cash paid by a customer exceeds this threshold amount, the system will display the IRS form to gather additional customer information.
- Display rounded cash total. - Only applicable for currency rounding; indicates whether the rounded cash total is displayed below the transaction total in the viewport.
- Export hashed account number. - Determines whether or not to include the hashed account number in PosLog.xml.

- Inform users with a message that no signature is required. - This option controls turning off/on the information message displayed when processing a transaction below a configured value.
- Method used for masking vouchers and gift card numbers.. - Enter the voucher number masking method.
  - CREDITCARD - Mask all but the last 4-digits of the Account Number.
  - MASK\_LAST\_4 - Mask (\*\*\*\*) the last 4-digits of the Account Number.
- Define the minimum check number the system will accept. - Enter the lowest check number the system will accept when the customer pays with a check.
- Prompt for birth date when a check is tendered. - Determines whether the system prompts for the customer's birthdate when the customer pays with a check.
- Require pin pad entry for debit tender. - Determines whether a pin pad device is required for tendering with a debit card.
- Specify the rounding Method to use for local currency. - Select the local currency amount rounding method.
  - Half Up - Round to the nearest neighbor unless equidistant, then round up.
  - Half Down - Round to the nearest neighbor unless equidistant, then round down.
  - Half Even - Round to the nearest neighbor unless equidistant, then round to even neighbor. Example: 2.5 rounds to 2 while 3.5 rounds to 4.
  - Ceiling - Round toward positive infinity. Note: This is the opposite of FLOOR and never decreases the calculated value.
  - Down - Round to the next digit; closer to zero.
  - Floor - Round down toward negative infinity. Note: This is the opposite of CEILING and never increases the calculated value.
  - Up - Round to the next digit; away from zero.
  - Unnecessary - Rounding is not necessary.

## Till Accountability

- Count method used for store safe deposit. - The store bank deposit till count method. This configuration is only valid if the store requires an end count of the store bank at store close. Valid Values:
  - Storebank Complete - Brings up the entire store bank end count screen for all tenders.
  - Remaining Cash - Prompt the user to enter the total cash NOT to be deposited to the bank institution.
  - Complete Deposit - Deposit all tenders from the store bank to the bank institution.
- Skip initial count summary. - When initiating a count, determines whether the system displays the tender summary list or the first tender to be counted.
- Validate cash refund amounts against the current till count. - Determines whether the system validates refund cash amounts to ensure the current till cash amount is greater than the refund cash amount.

# Configuring Customer Displays

...continued from step 4

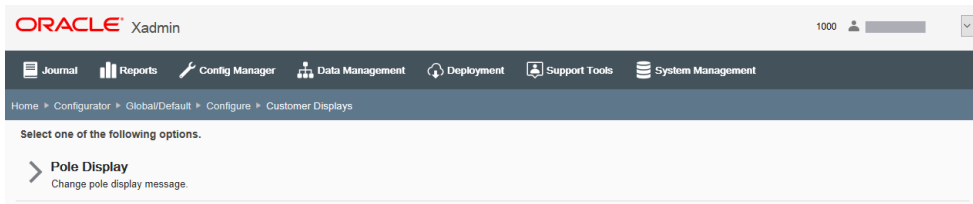


## Note:

Pole Display is the only Customer Display type supported at this time.

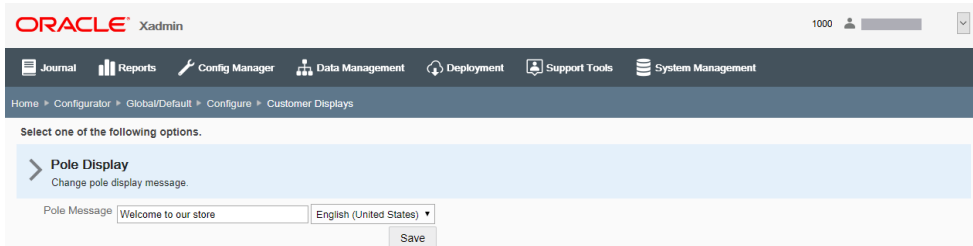
1. At the Customer Display page, click **Pole Display**.

**Figure 5-54 Customer Display Page**



2. The current pole display message is shown in the Pole Message field. Edit the pole display message as needed:

**Figure 5-55 Edit Pole Display Page**



- **Pole Message** - To edit the message text, type the new message. The maximum length is 40 characters.
- **Locale** - If needed, select a translation locale and enter the message text for the locale.



## Note:

A pole message is required for the default locale. A pole message is not required for other locales you may have set up.

3. Click **Save**.

# Deploying Configuration Changes

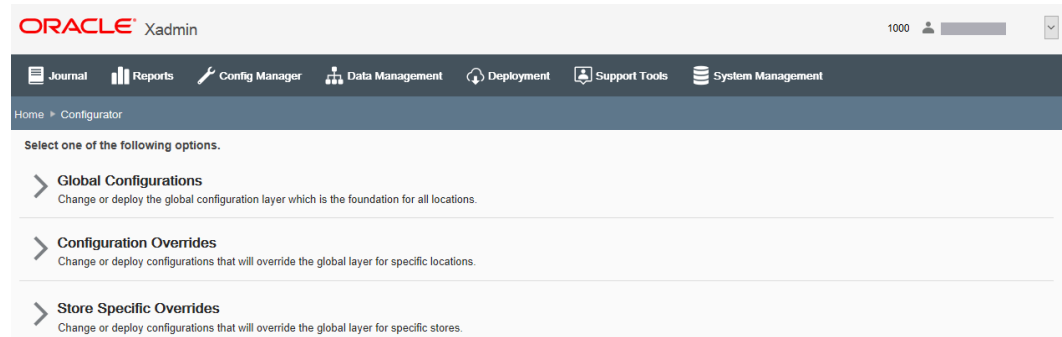


## Note:

See [Appendix: About Deployments](#) for more information about deployments.

1. To begin the deployment process, from the Oracle Retail Xstore Office menu, select **Config Manager - Configurator**, or click the Configurator link in the Configuration Manager panel.
2. Select the configuration scope for the deployment:

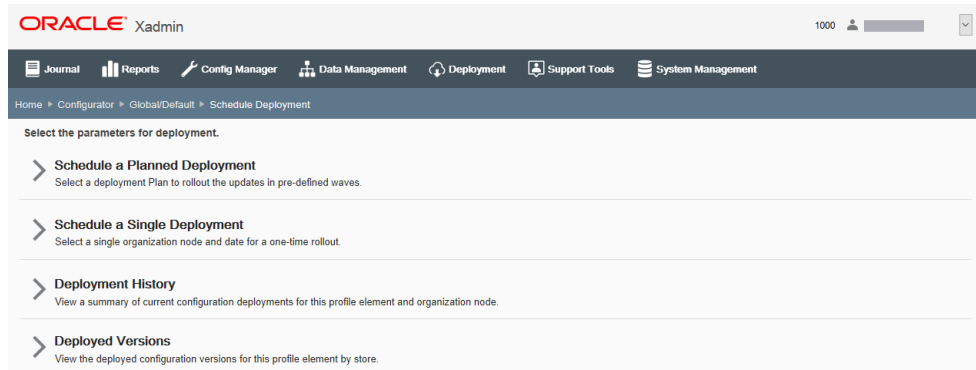
**Figure 5-56 Configuration Scope Options Page**



- Select **Global Configurations** to deploy the global configuration layer which affects all locations. Continue with step 3 below.  
<OR>
- Select **Configuration Overrides** to deploy configurations that will override the global layer for specific locations.
  - a. Select a Profile Group from the list.
  - b. Select an Element from the list.
  - c. Click **Next**.
  - d. Continue with step 3 below.<OR>
- Select **Store Specific Overrides** to change configurations that will override the global layer for a specific store based on the user's scope.
  - a. Type the store number or begin typing a store number or name in the Store # field.
  - b. Select the store from the store list.
  - c. Click **Next**.
  - d. Continue with step 3 below.

3. At the Configuration Action page, select the **Deploy** option.
  - If you try to schedule a deployment for a profile element that has no changes, you will see the following message:  
There are no changes to deploy for this profile element.
  - If you see this message, return to the Configure screen and make your changes before scheduling a deployment.
4. At the Schedule Deployment page, select a deployment type:

**Figure 5-57 Schedule Deployment Page - Global Scope Example**



- Select **Schedule a Planned Deployment** to roll out the updates in pre-defined waves. Continue with Scheduling a Planned Deployment.

 **Note:**

The Planned Deployment option is not available for Store Specific Overrides.

<OR>

- Select **Schedule a Single Deployment** to set up a one-time rollout. Continue with Scheduling a Single Deployment.
  - To view deployment history for this profile element and organization node, select Deployment History. See [Deployment History](#) for more information about this option.
  - To view the deployed configuration versions for this profile element by store, select Deployed Versions. See [Deployed Versions](#).

## Scheduling a Planned Deployment



### Note:

You must create deployment plans before using this option. Refer to [Deployment Management, Creating a Deployment Plan](#) for more information about setting up deployment plans.

1. Complete the following fields to roll out the updates in pre-defined waves:
  - **Deployment Name** -Accept the default name or enter a name for this deployment.
  - **Deployment Plan** - Select a deployment plan from the list.
  - **Target Date** - Select the date the changes will be sent to the store.
2. Click **Next**.
3. Review the deployment schedule.

**Figure 5-58 Review Deployment Schedule Page**

Wave #	Name	Date	Launch Type	Organization Nodes	# of Stores
1	Wave 1	Mon, Sep 17, 2018	Approval Required	STORE:301	1
2	Wave 2	Tue, Sep 18, 2018	Approval Required	STORE:302, STORE:303, STORE:304, STORE:305	4
3	Wave 3	Fri, Sep 21, 2018	Approval Required	STORE:306, STORE:307, STORE:308, STORE:309, STORE:310, STORE:311, STORE:312, STORE:313, STORE:314	9

4. Verify the Email Notification List is correct. If needed, click the View List link to see more detail about the email recipients.
5. Review the deployment information:
  - The "v.x" value in the Deployment Name is the configuration version for this deployment.

**Figure 5-59 Example Deployment Name**

<b>Deployment Name</b>	<b>Various Updates Global Config v.32 2018-09-14 09:16:55</b>
<b>Deployment Plan</b>	<b>Plan 300</b>
<b>Total # of Stores</b>	<b>14</b>

6. If the deployment information is correct, click **Deploy**.

- If a deployment has already been scheduled with an earlier version of configurations, you will be prompted to change the deployment date. Use the breadcrumbs to return to the Schedule Deployment page and change the date for deployment.
  - If the deployment information is not correct, use the breadcrumbs to navigate back to the previous page where you can make changes, and go to step 1 on page 67.
7. When prompted, click **Yes** to confirm you want to schedule deployment.
  8. Click **OK** to close the Deployment was scheduled successfully window. The configuration version is now "locked" for this set of configurations.

## Scheduling a Single Deployment

1. Complete the following fields for a one-time rollout:
  - **Deployment Name** - Accept the default name or enter a name for this deployment.
  - **Organization Node** - Select the organization target for the configuration changes.
  - **Target Date** - Select the date the changes will be sent to the store.
  - **Download Priority** - Select the download priority:
    - **Immediate** - Download the configuration changes now.
    - **Store Close** - Download the configuration changes at end-of-day.
2. Click **Next**.
3. Review the deployment schedule.

**Figure 5-60 Review Deployment Schedule Page**

ORACLE Xadmin 1000

Journal Reports Config Manager Data Management Deployment Support Tools System Management

Home > Configurator > Global/Default > Schedule Deployment > Review Deployment Schedule

Deployment Name: Various Updates Global Config v.2 2018-07-18 15:49:35  
 Deployment Plan: Single Wave  
 Total # of Stores: 1

Waves Deploy

Wave #	Name	Date	Launch Type	Organization Nodes	# of Stores
1	Default Wave	Wed, Jul 18, 2018	Automatic - End of Day	STORE:302	1

4. Review the deployment information:
  - The "v.x" value in the Deployment Name is the configuration version for this deployment.
5. If the deployment information is correct, click **Deploy**.
  - If a deployment has already been scheduled with an earlier version of configurations, you will be prompted to change the deployment date. Use the breadcrumbs to return to the Schedule Deployment page and change the date for deployment.
  - If the deployment information is not correct, use the breadcrumbs to navigate back to the previous page where you can make changes, and go to step 1 on page 67.

6. When prompted, click **Yes** to confirm you want to schedule the deployment.
7. Click **OK** to close the Deployment was scheduled successfully window. The configuration version is now "locked" for this set of configurations.

## Viewing Configuration Changes

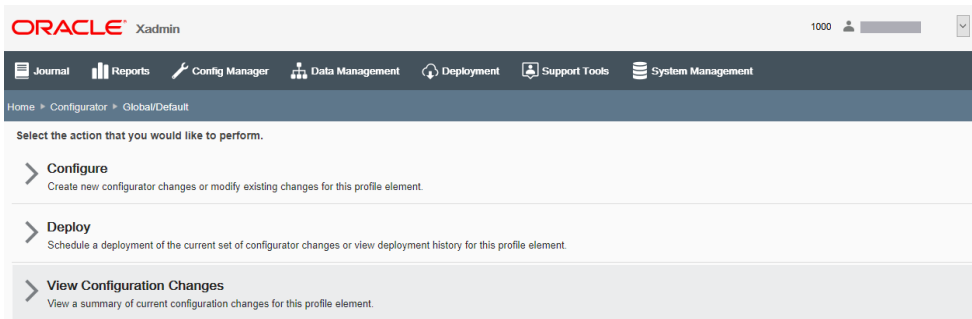
A Configuration Change is recorded when a configurable object has been altered. Multiple alterations of a configurable object does not equate to multiple changes being recorded.

For example, if you change the same reason code three separate times, it counts as one change for the time period that it differs from the global configuration. If you change three different reason codes, that would count as three changes.

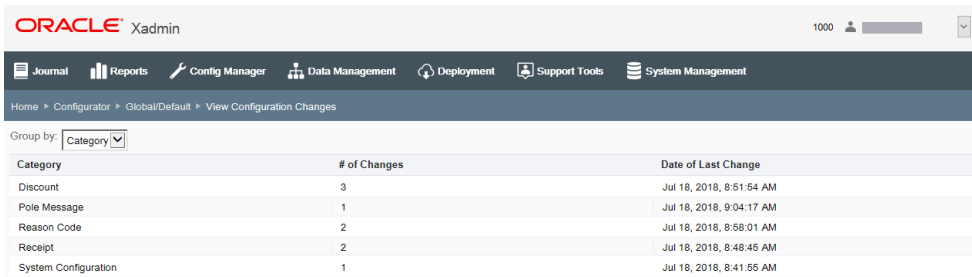
This feature provides a summary list of configuration changes, who made them, and when they were made. This list is only a "snapshot" of time in which it is called up. When viewing configuration changes, you can delete configuration changes that have not been deployed. See [Delete Configuration Changes](#) for more information.

1. From the Oracle Retail Xstore Office menu, select **Config Manager - Configurator**, or click the Configurator link in the Configuration Manager panel.
2. Select the configuration scope for the deployment. The process varies with the scope selected on the Configuration Scope Options page (Figure 5-36):
  - **Global Configurations** - continue with step 3 below.
  - **Configuration Overrides:**
    - Select a Profile Group from the list.
    - Select an Element from the list.
    - Click **Next**.
    - Continue with step 3 below.
  - **Store Specific Overrides:**
    - Type the store number or begin typing a store number or name in the Store # field.
    - Select the store from the store list.
    - Click **Next**.
    - Continue with step 3 below.
3. At the Configuration Scope Actions page, select View Configuration Changes.



**Figure 5-61 Configuration Scope Actions Page - Global Example**


4. View the configuration changes by Category or by Version:

**Figure 5-62 Configuration Changes Page: by Category or Version**


Category	# of Changes	Date of Last Change
Discount	3	Jul 18, 2018, 8:51:54 AM
Pole Message	1	Jul 18, 2018, 9:04:17 AM
Reason Code	2	Jul 18, 2018, 8:58:01 AM
Receipt	2	Jul 18, 2018, 8:48:45 AM
System Configuration	1	Jul 18, 2018, 8:41:55 AM

 **Note:**

Click the sort component to sort the columns as needed.

- **Group By Category:**
  - **Category** - The configuration category. Select the Category row to view more information: Version Number, Change Description, Date of Last Change, and User.
  - **# of Changes** - The number of changes per category.
  - **Date of Last Change** - The date the last configuration change was made for this category.
- **Group By Version:**
  - **Version #** - The configuration version number. Select the Version # row to view the configuration changes made to that version: Category, Change Description, Date of Last Change, and User.
  - **# of Changes** - The number of changes in this version.
  - **Date Created** - The date the version was created.

## Delete Configuration Changes

When viewing configuration changes, you can remove a configuration change (or several changes if applicable) from a configuration update as long as that configuration update has not been deployed.

1. From the Oracle Retail Xstore Office menu, select **Config Manager - Configurator**, or click the Configurator link in the Configuration Manager panel.
2. Select the configuration scope for the deployment.
3. At the Configuration Scope Actions page, select **View Configuration Changes**.
4. View the configuration changes by Category or by Version.
5. Click the Delete icon associated with the configuration change you want to remove.

**Figure 5-63 Configuration Changes Page - Delete Option**

Version #	Change Description	Date of Last Change	User	
2	Discount	Jul 18, 2018, 8:57:49 AM	1	X
2	Discount	Jul 18, 2018, 8:51:54 AM	1	X
2	Discount	Jul 18, 2018, 8:46:23 AM	1	X

6. When prompted to confirm you want to delete this change, click **Yes** to remove the configuration change from the configuration update.

## Delete Profile Configuration Overrides

Use this option to delete group/element level configuration overrides for a specified group/element configurations.



### Note:

To use this feature, "Enable the Option to Delete Configurations?" must be set to true in Oracle Retail Xstore Office Settings.

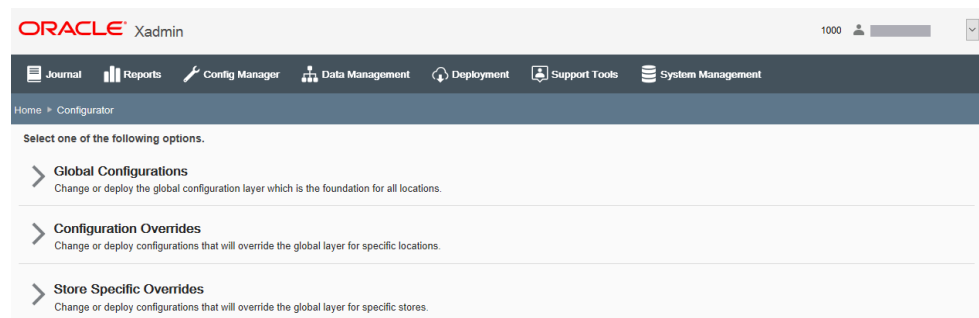
 **Note:**

When you delete store level or profile group/element level configurations, a deployment is scheduled for those locations to be sent immediately.

If there are any pending configuration deployments for the same location at a future date, the location will receive this delete deployment immediately, and then at a later time the scheduled configurations will be deployed. If this scenario occurs, Oracle Retail Xstore Point of Service and Oracle Retail Xstore Office will have different configurations for that location.

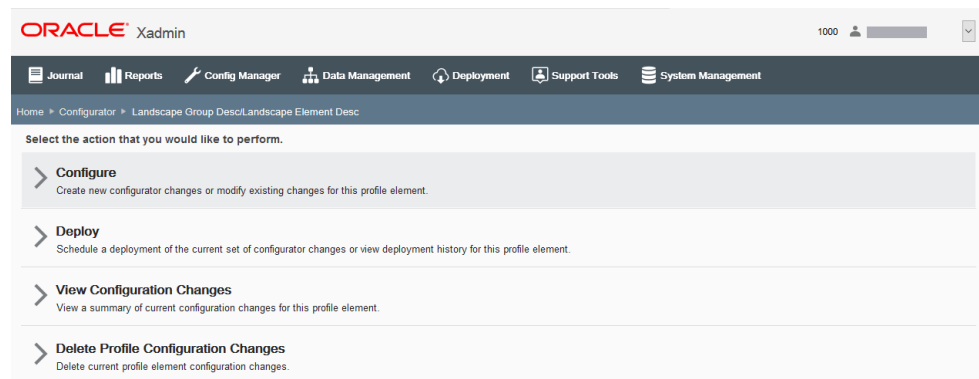
1. At the Configuration Scope Options page, select **Configuration Overrides**.

**Figure 5-64 Configuration Scope Options Page**



2. Select the profile group and element, then click **Next**.
3. At the Configuration Action page, click **Delete Profile Configuration Changes**.

**Figure 5-65 Configuration Action Page - Configuration Overrides Scope Example**



4. When prompted, click **Yes** to confirm the deletion.
5. After the deployment has been scheduled successfully, click **OK** to close the Schedule Delete Configurations Deployment prompt.
6. When prompted, click **OK** to acknowledge all the changes have been removed.

## Delete Store Specific Overrides

Use this option to delete store-specific configuration overrides. Oracle Retail Xstore Office deletes configurations that have not been deployed and marks the deployed profile configuration changes as inactive in the Oracle Retail Xstore Office database. This action retains the history of completed deployments for auditing purposes.

### Note:

To use this feature, "Enable the Option to Delete Configurations?" must be set to true in Xadmin Settings.

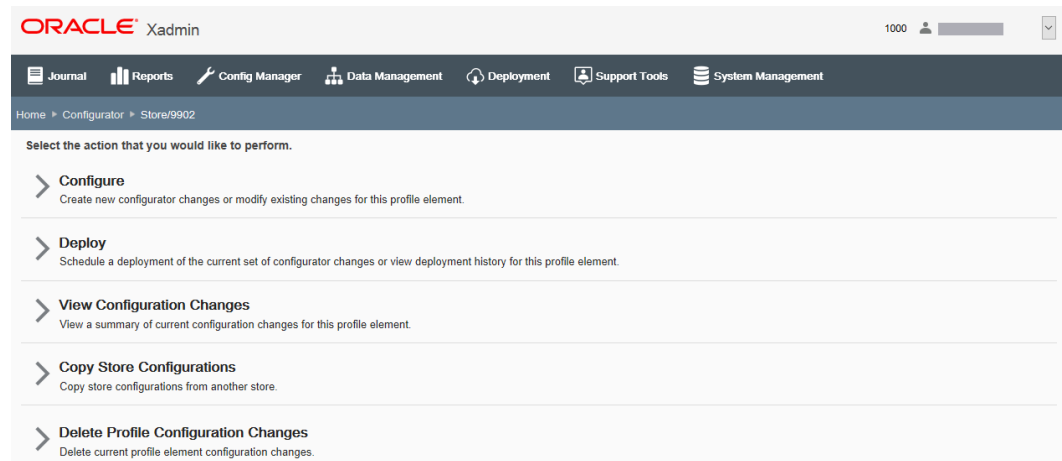
### Note:

When you delete store level or profile group/element level configurations, a deployment is scheduled for those locations to be sent immediately.

If a scheduled deployment for configuration changes is found, you will not be able to delete a profile configuration change.

1. At the Configuration Scope Options page (Figure 5-58), select **Store Specific Overrides**.
2. Select the store number, then click **Next**.
3. At the Configuration Action page, click **Delete Profile Configuration Changes**.

**Figure 5-66 Configuration Action Page - Store Specific Overrides Scope Example**



4. When prompted, click **Yes** to confirm the deletion.
5. After the deployment has been scheduled successfully, click **OK** to close the Schedule Delete Configurations Deployment prompt.
6. When prompted, click **OK** to acknowledge all the changes have been removed.

## Copy Store Configurations



### Note:

To use this feature, "Enable the Option to Create Store? Specific Configurations?" must be set to true in Xadmin Settings.

Use this option to copy configuration information from one store to another. You must have access privileges to both the copy-from store and the copy-to (destination) store in order to use this process. Only stores are valid for the copy-from and destination locations, no other hierarchy or store collections are supported. The target store's previous configurations are retained (but tagged as inactive) for auditing purposes.



### Note:

This option is not allowed when a scheduled deployment is pending.

1. At the Configuration Scope Options page (Figure 5-58), select **Store Specific Overrides**.
2. Enter the target store number in the Store # field and click **Next**.
3. At the Configuration Action page, click **Copy Store Configurations** (Figure 5?62) and enter the store number you want to copy configurations from in the Copy From Store # field.
4. Click **Next**. This action tags any previously implemented changes as inactive in the database.
5. When prompted, click **Yes** to confirm the copy instructions.

**Figure 5-67 Configuration Copy Prompt**

Configuration changes copied to Store/9902. Changes must be deployed to complete the process. Press OK to view your changes.

OK

The configurations are copied to the destination store:

- If the destination store is new, then all the configurations from the copy-from store are now available.
  - If the destination store previously existed, then the system will overwrite the previous data with the new data from the copy-from store.
6. When prompted, click **OK** to view the configuration changes.

**Figure 5-68 Configuration Copy Confirm Prompt**

Configuration changes copied to Store/9902. Changes must be deployed to complete the process. Press OK to view your changes.

OK

7. Review configuration changes by Category or by Version.
8. Continue with Deploying Configuration Changes to deploy the changes.

**Figure 5-69 View Configuration Changes Page**

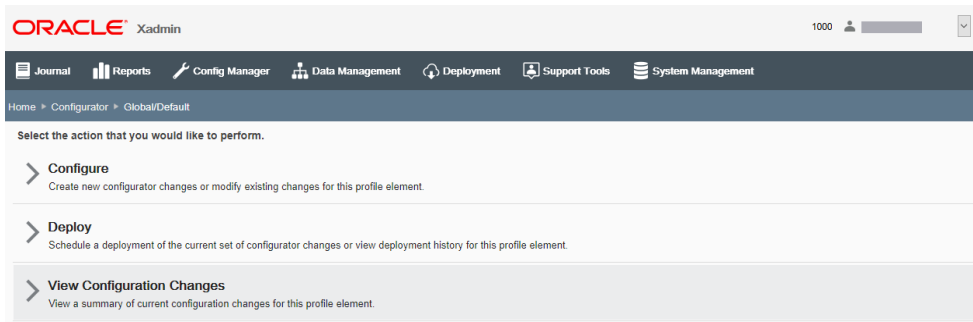
Category	# of Changes	Date of Last Change
System Configuration	1	Sep 14, 2018, 11:41:39 AM

## Deployment History

Use Deployment History to view a summary of current configuration deployments for the profile element and organization node.

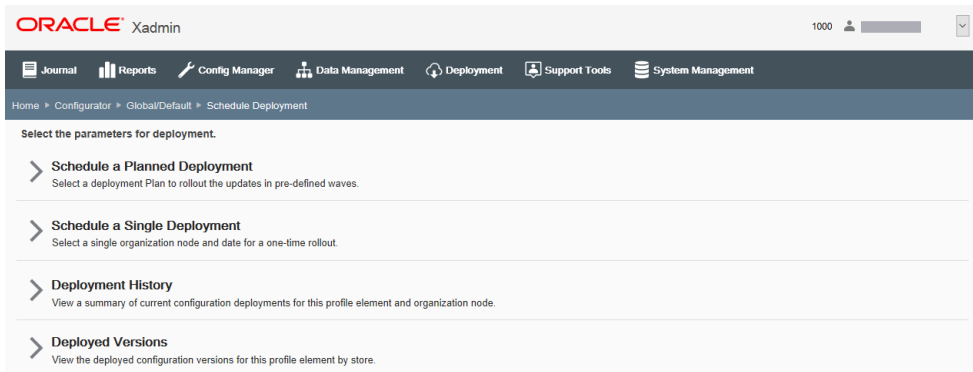
1. From the Oracle Retail Xstore Office menu, select **Config Manager - Configurator**, or click the Configurator link in the Configuration Manager panel.
2. Select the configuration scope for the deployment. The process varies with the scope selected on the Configuration Scope Options page (Figure 5-36):
  - **Global Configurations** - continue with step 3 below.
  - **Configuration Overrides:**
    - Select a Profile Group from the list.
    - Select an Element from the list.
    - Click **Next**.
    - Continue with step 3 below.
  - **Store Specific Overrides:**
    - Type the store number or begin typing a store number or name in the Store # field.
    - Select the store from the store list.
    - Click **Next**.
    - Continue with step 3 below.
3. At the Configuration Scope Actions page, select **Deploy**.

**Figure 5-70 Configuration Scope Actions Page - Global Example**



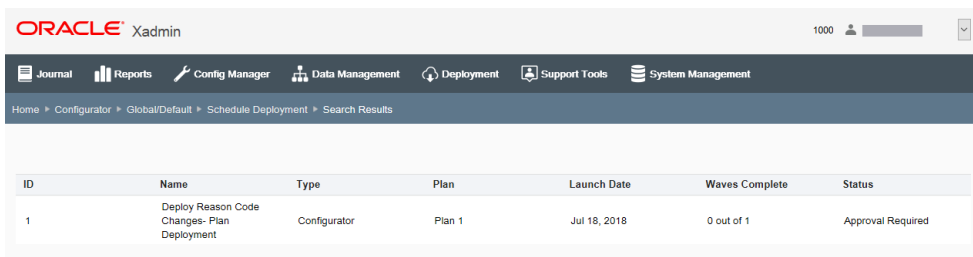
4. At the Schedule Deployment Page, select **Deployment History**:

**Figure 5-71 Schedule Deployment Page - Global Scope Example**



5. The Deployment History search results list shows the other configurator deployments of the same Org Node/Element, along with the status for each.

**Figure 5-72 Deployment History Search Results List**

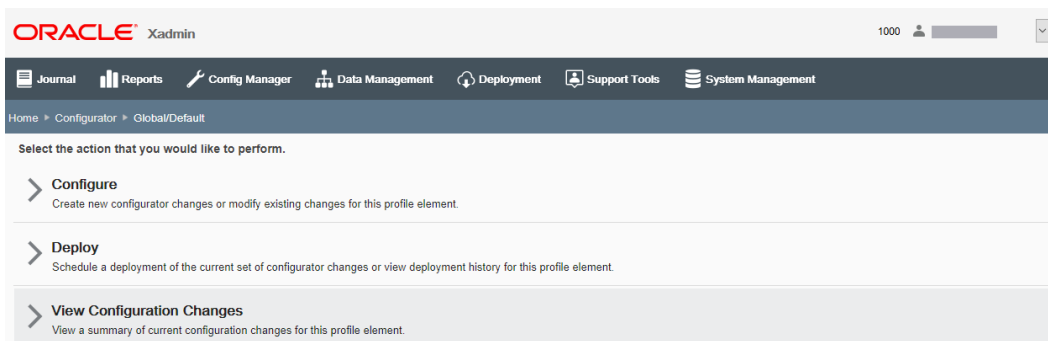


6. Select a deployment to view additional detail. If needed, a deployment can be edited. See [Deployment Management](#), section [Viewing Deployments](#) for more information about Deployment History and editing deployments.

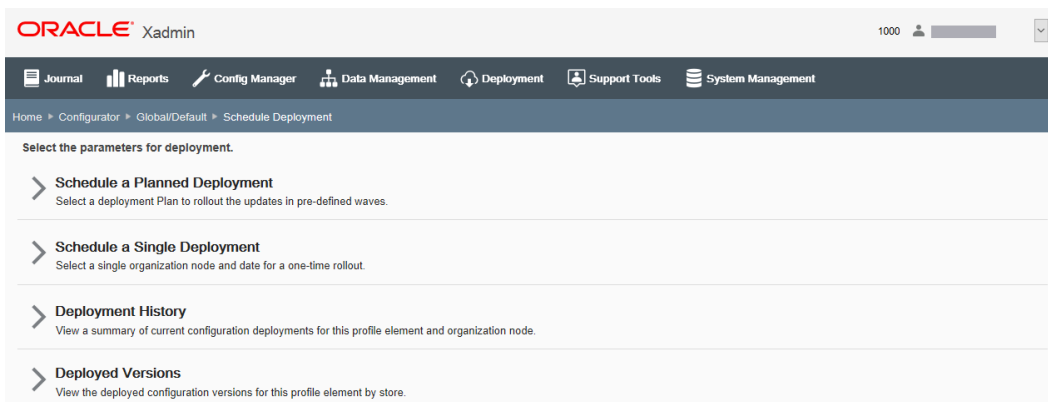
## Deployed Versions

Use Deployed Versions to view the number of stores, and the version numbers deployed to those stores, in a pie chart format. This version information is reported to Oracle Retail Xstore Office by the primary register at the store.

1. From the Oracle Retail Xstore Office menu, select **Config Manager - Configurator**, or click the Configurator link in the Configuration Manager panel.
2. Select the configuration scope for the deployment. The process varies with the scope selected on the Configuration Scope Options page (Figure 5-36):
  - **Global Configurations** - continue with step 3 below.
  - **Configuration Overrides:**
    - Select a Profile Group from the list.
    - Select an Element from the list.
    - Click **Next**.
    - Continue with step 3 below.
  - **Store Specific Overrides:**
    - Type the store number or begin typing a store number or name in the Store # field.
    - Select the store from the store list.
    - Click **Next**.
    - Continue with step 3 below.
3. At the Configuration Scope Actions page, select **Deploy**.

**Figure 5-73 Configuration Scope Actions Page - Global Example**

4. At the Schedule Deployment Page, select **Deployed Versions**:

**Figure 5-74 Schedule Deployment Page - Global Scope Example**



5. With the pie chart displayed, click on a section to display a list of the stores to which the version number was deployed.

The pie chart represents the number of stores, and the version numbers deployed to those stores, based on the version reported from the primary register in the store.

The list includes the Store Name, Store ID, Phone Number, and Address.

# 6

## Data Management

Data Management is used to create, maintain, and deploy Oracle Retail Xstore Office data selectively, or globally across the entire organization. Data Management is also used to set up and maintain your organization hierarchy and store collections, and to initiate the end-of-year process to post the required roll-up data for stock valuation for all items and stores. The logged-in user is assumed to represent some tier of the organization. For this reason, the user's assigned org node hierarchy will determine the data he/she has access to. See [Roles, Users, and Security Access](#) for more information about users and security access. The following data can be configured in Data Management:

### In Data Manager

- Merchandise & Non Merchandise Items
- Vendors
- Employee Records
- Exchange Rates
- Store Information
- Taxes
- Store Messages
- Employee Tasks

### In Organization Hierarchy

- Organization Hierarchy Maintenance
- Organization Hierarchy Levels
- Store Collections

### In Roll-up Stock Valuation

- Stock Valuation Year End Roll-up

## About this Chapter

Data Management allows you to:

- Change or create data for your organization. See [Managing Data](#).
- View or deploy pending data changes for your organization. See [Viewing and Deploying the Data Changes](#).
- Redeploy data from one org node to another. See [Data Publisher - Redeploying Data](#).
- Set up or edit your organization hierarchy, including Store Collections. See [Managing the Organization Hierarchy](#).
- Initiate the end-of-year process to post the required roll-up data for stock valuation for all items and stores. See [Stock Valuation Year End Roll-Up](#).

## Where To Look For Additional Information

- *Oracle Retail Xstore Point of Service Database Dictionary* - The Oracle Retail Xstore Point of Service Database Dictionary Guide provides Oracle Retail Xstore Point of Service database detail and schema information. This dictionary provides a description of each table as well as a listing of all of the columns in each table.
- *Oracle Retail Xstore Office Database Dictionary* - The Oracle Retail Xstore Office Database Dictionary Guide provides Xcenter (a part of Oracle Retail Xstore Office) database detail and schema information. This dictionary provides a description of each table as well as a listing of all of the columns in each table.
- *Oracle Retail Xstore Point-of-Service Host Interface Guide* - The Oracle Retail Xstore Point-of-Service Host Interface guide provides information about the files accepted for processing updates to Oracle Retail Xstore Point of Service operating tables. In addition, this guide also provides information about the DataLoader application that is responsible for translating flat data files into database data that can be used by Oracle Retail Xstore Point of Service.

## About Data Management

Data Manager changes are collected into "data bundles" containing all of the changes made within a particular org level during a given day. The changes collected in the data bundle will be deployed to their targeted stores automatically at the end of the day, or can be deployed immediately if needed. When you make changes in Data Manager and deploy them, they automatically update the Xcenter database; there is no DataLoader file created and no DataLoader processing necessary. If anything fails, it can be found in the Xcenter or Oracle Retail Xstore Office log file.

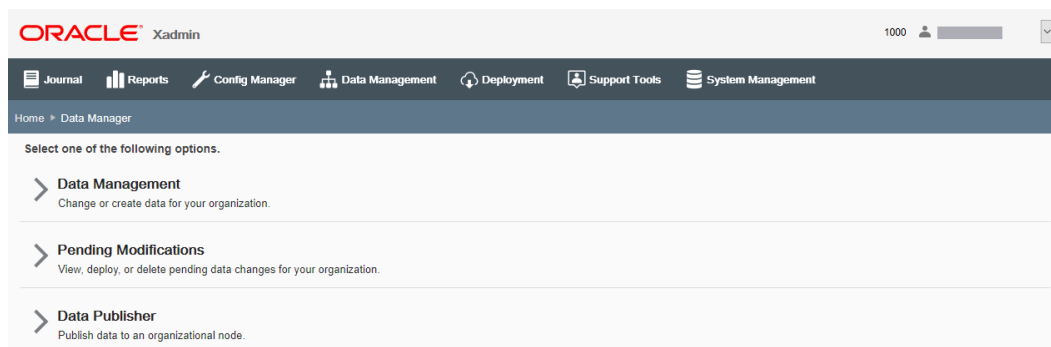
Use the **Pending Modifications** feature of Data Manager to delete or view the details of the data bundles before they are deployed.

Use the **Data Publisher** feature to deploy data from Xcenter to an org node. Deployed data will include all the data available to the targeted org node (within the categories selected by the user) and comes from Xcenter.

## Managing Data

1. From the Oracle Retail Xstore Office menu, select **Data Management - Data Manager**, or click the Data Manager link in the Data Management panel.
2. At the Data Manager page, you have the following options:

Figure 6-1 Data Manager Page



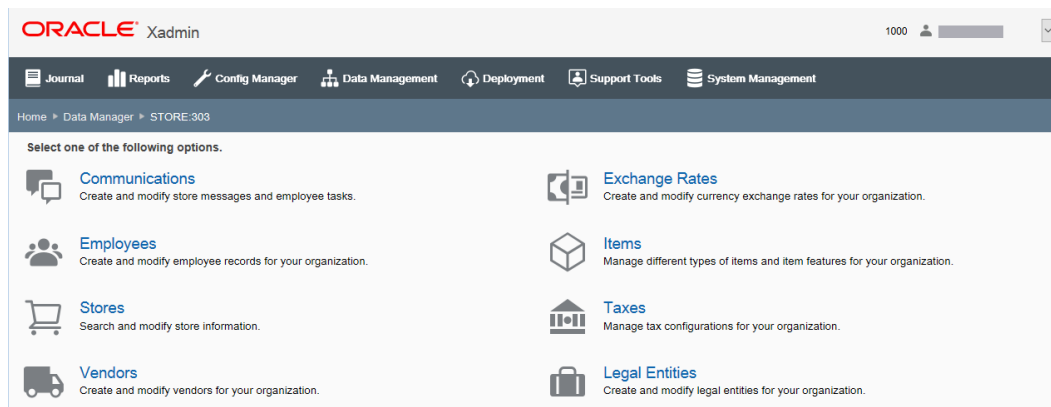
- To change or create data for your organization, click **Data Management**. Continue with step 3 below.
  - To view or deploy pending data changes for your organization, click **Pending Modifications** and skip to Viewing and Deploying the Data Changes.
  - To transfer data from one org node to another, click Data Publisher and skip to Data Publisher - Redeploying Data, step 3.
3. Select the Organization Node for the Data change, then click **Next**.

 **Note:**

Only the Organization Nodes the logged-in user has privileges to use will be listed here.

4. Select a Data option.

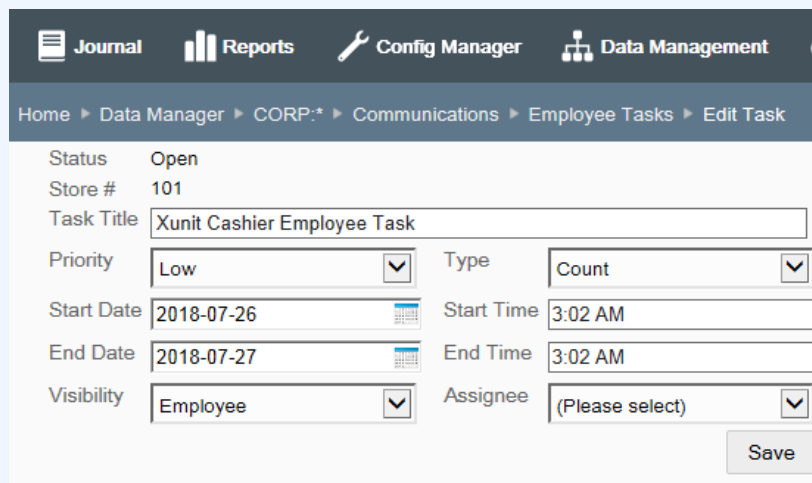
Figure 6-2 Data Manager Options Page



5. At the page for the selected Data option you can add a new record or modify an existing record:
  - To add a new record for the Data option using the wizard format, click **Add New**.

 **Note:**

For Data options that do not use a wizard format, information is added and edited in a Data window. After completing the required fields, click **Save**.



When adding a new record to a Data option, all fields will be blank.

- To edit an existing record for the Data option, click the record to open the editing window. When editing a Data option record, some fields cannot be changed.
6. Follow the prompts to manage the data for the selected option:
    - After completing a page, click **Next** when applicable to navigate to the next page until setup is complete.
    - You can click **Previous** to return to the previous page when applicable.
    - The breadcrumbs displayed at the top of each page can be used to navigate through the various pages of the activity.
    - In addition to the breadcrumbs at the top of each page, the side panel on each page shows where you are in the process and can also be used to navigate the various steps of the process as needed.
    - To exit without saving any changes, click **Cancel**. When prompted, click **Yes** to confirm you do not want to save any changes.
  7. When setup is complete, and you have reviewed your changes, click **Save**.

## Data Manager Options

- **Communications** - Use this feature to create and modify store messages and employee tasks.
- **Employees** - Use this feature to create and modify employee records for your organization.

- [Stores](#) - Use this feature to search for and modify store information.

 **Note:**

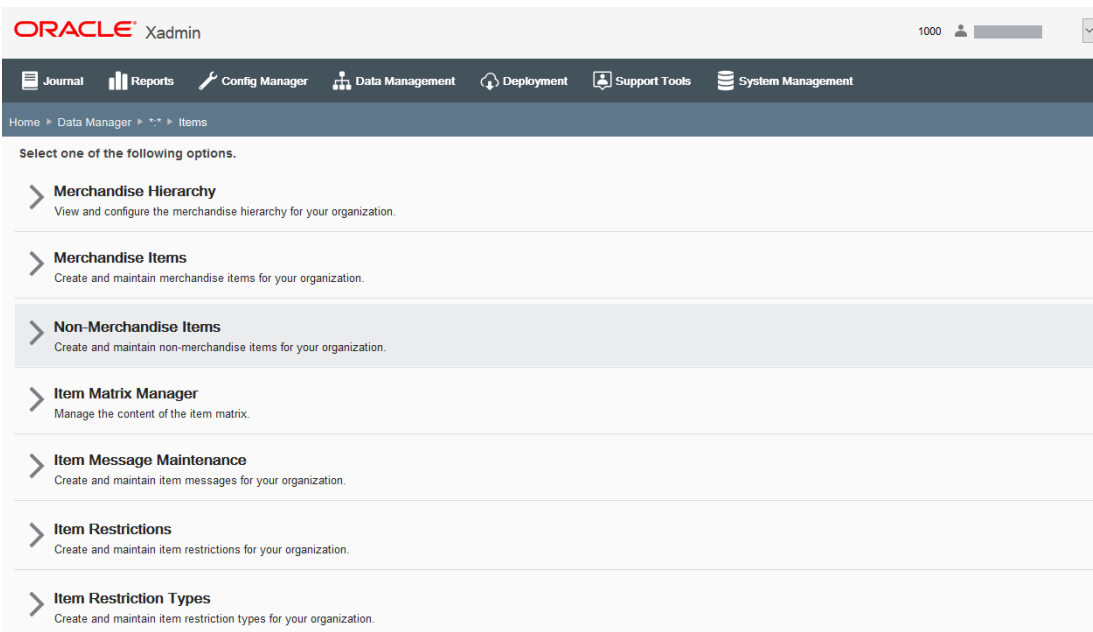
This Data Manager Stores option allows you to search for and modify store information for an existing store only. To set up a new store, see [Managing the Organization Hierarchy](#).

- [Vendors](#) - Use this feature to create and modify vendors for your organization.
- [Exchange Rates](#) - Use this feature to create and modify currency exchange rates for your organization.
- [Items](#) - Use this feature to manage different types of items, non-merchandise items, and item matrix features for your organization and to manage the merchandise hierarchy.
- [Taxes](#) - Use this feature to manage tax configurations for your organization.
- [Legal Entities \[Country Pack ONLY\]](#) - Use this feature to create and modify legal entities for your organization.

## Items

Use this feature to manage different types of items and item features for your organization.

**Figure 6-3 Data Manager - Items Page**



- To manage the merchandise hierarchy, click **Merchandise Hierarchy**. See [Merchandise Hierarchy](#).
- To create and manage merchandise items (including prices and attached items), click **Merchandise Items**. See [Merchandise Items](#).

- To create and manage non-merchandise items (including prices), click **Non-Merchandise Items**. See [Non-Merchandise Items](#).
- To manage the item matrix settings, click **Item Matrix Manager**. See [Item Matrix Manager](#).
- To create and maintain item messages, click Item Message Maintenance. See [Item Message Maintenance](#).
- To create and maintain item restrictions, click **Item Restrictions**. See [Item Restrictions](#).
- To create and maintain item restrictions, click **Item Restriction Types**. See [Item Restriction Types](#).

## Merchandise Items

...continued from [Items](#)

**Figure 6-4** Items Page

ORACLE Xadmin 1000

Journal Reports Config Manager Data Management Deployment Support Tools System Management

Home > Data Manager > \*\* > Items

Select one of the following options.

> Merchandise Hierarchy  
View and configure the merchandise hierarchy for your organization.

> Merchandise Items  
Create and maintain merchandise items for your organization.

Create a new merchandise item.

Add New

Find and edit a merchandise item.

Item ID	Equals	
Description	Equals	
Department	Equals	(Please select)
Subdepartment	Equals	(Please select)
Class	Equals	(Please select)
Subclass	Equals	(Please select)

Search

If adding a new item:

At the Item Maintenance page, click **Add New** to create a new item.

If editing an existing item:

At the Item Maintenance page, enter search criteria and click Search to find/edit an existing item in your organization. If you do not enter any criteria before selecting Search, all items in your organization will be returned in the search. To edit information for an existing item, select the row from the search results list and click Edit at the Item Information window (Figure 6-5).

**Note:**

To view and/or edit item prices, refer to [Item Prices](#) for procedural information.

See step 6 for additional procedural information.

The following Item Maintenance fields are available:

**Table 6-1 Basic Merchandise Information**

Field	Description
Item ID [REQUIRED]	Enter the item identifier. This field cannot be edited for existing items.
Description [REQUIRED]	Enter the item description.
Prompt for Description check box	Select this check box if the item description must be manually entered when this item is sold.
Tax Group [REQUIRED]	Select the item's tax group from the drop-down list. Possible values are from the Tax Group table (tax_tax_group).
Availability	Select the product availability to determine whether or not an item is available for sale: Available, Not Sellable at POS, or Recalled.
Stock Status check box	If applicable, select this option and type the item's status based on its stock availability when prompted for a value. For example, RESTRICTED_QTY, DISCONTINUED, CLEARANCE, and so on.
Commission check box	If applicable, select this option if the item qualifies for commission.
Attached Items check box	Select this option if the item has attached items. (See <a href="#">Attached Items</a> for more information about setting up attached items.)
Serial Number check box	Select this option if a serial number is required.
Selling Group ID	If you assign an item to a selling group, the item can not be sold in any transaction containing items from a different selling group.

**Table 6-2 Merchandise Attributes**

Field	Description
Department	Select the item's department from the drop-down list. Possible values are from the itm_merch_hierarchy table where level code is DEPARTMENT.
Subdepartment	Select the item's subdepartment from the drop-down list. Possible values are from the itm_merch_hierarchy table where level code is SUBDEPARTMENT.
Class	Select the item's class from the drop-down list. Possible values are from the itm_merch_hierarchy table where level code is CLASS.
Subclass	Select the item's subclass from the drop-down list. Possible values are from the itm_merch_hierarchy table where level code is SUBCLASS.
Style check box	Select this option if the item is associated with a style, then enter the style ID when prompted.
Season check box	Select this option if the item is associated with a season, then enter the season code when prompted.



**Table 6-2 (Cont.) Merchandise Attributes**

Field	Description
Vendor check box	Select this option if the item is associated with a vendor, then select the vendor from the drop-down list when prompted.
Item UPCs	Enter the UPC for the item and click Add. You can enter as many UPCs as needed. After adding at least one UPC, a Delete option will be available to remove a UPC if needed.

**Table 6-3 Quantity Attributes**

Field	Description
Sale Quantity check box	Select this option if the item quantity cannot be changed from 1. <b>Note:</b> This option will disable all other item quantity options listed here.
Quantity Prompt check box	Select this option if the item quantity must be manually entered when this item is sold.
Weight Prompt check box	Select this option if the item weight must be manually entered when this item is sold.
Initial Sale Quantity check box	Select this option if the item is sold in a quantity other than one. If selected, enter the initial quantity at which this item must be sold.
Minimum Sale Quantity check box	Select this option if the item has a minimum sale quantity. If selected, enter the minimum quantity of this item that may be sold in a single transaction.
Maximum Sale Quantity check box	Select this option if the item has a maximum sale quantity. If selected, enter the maximum quantity of this item that may be sold in a single transaction.  If a value is not specified, the system configuration for maximum quantity per sale item is used. If a value is specified here and it is greater than the system configuration value, the maximum sale quantity is used.

**Table 6-4 Customer Related Attributes**

Field	Description
Customer Information Required check box	Select this option if the system prompts for customer information when the item is sold. If selected, a prompt for information will be displayed. Select whether the information is required or optional: Prompt, entry is required Prompt, entry is optional
Purchaser Minimum Age Required check box	Select this option if a minimum age is required to purchase the item. If selected, enter the minimum age (in years) required to purchase the item.

**Table 6-5 Item Restriction Attributes**

Field	Description
Inventoried check box	Select this option if inventory levels are tracked for this item.

**Table 6-5 (Cont.) Item Restriction Attributes**

Field	Description
Item Type Restrictions:	
Disallow Layaway check box	Select this option if this item cannot be added to a layaway transaction type.
Disallow Order check box	Select this option if this item cannot be ordered via Oracle Retail Order Broker Cloud Service Order functionality.
Disallow Rain Check check box	Select this option if this item is not eligible for rain check functionality.
Disallow Returns check box	Select this option if this item cannot be added to a return transaction type.
Disallow Send Sale check box	Select this option if this item cannot be added to a send sale transaction type.
Disallow Special Order check box	Select this option if this item cannot be added to a special order transaction type.
Disallow Work Order check box	Select this option if this item cannot be added to a work order transaction type.
Price Change Restrictions:	
Disallow Deal check box	Select this option if this item does not qualify for deals.
Disallow Discount check box	Select this option if this item cannot be discounted.
Disallow Price Change check box	Select this option if this item price cannot be changed.

**Table 6-6 Values Attributes**

Field	Description
Unit Cost	Enter the cost for each retail sale unit of this item.
Initial List Price	Enter the retail price per sale unit of the item.
Prompt for Price check box	Select this option if the retail price must be manually entered when this item is sold.

## Item Prices

When viewing item information, and if the selected item record is within your targeted org node, there is an option available to view and edit item pricing information. You can edit prices for your org node level only. However, you can view prices set above your org node level.

1. At the Item Maintenance page (Figure 6-4), enter search criteria and select Search to find/edit an existing item in your organization.
2. At the Item search results list, select the item row from the list.
3. Click **Prices** at the Item Information window.

**Figure 6-5 Item Information Window**

**Item 514000**
Prices Edit

**General Information**

Item ID 514000  
 Description Summer Cotton Shorts  
 Initial List Price None  
 Style ID N/A  
 Serialized Item Yes  
 Measurement Required No  
 Inventory Levels Tracked Yes  
 Department 510 Subdepartment 510300  
 Class 510300300 Subclass N/A  
 Item UPCs None

**Selling Details**

Prompt for Description No  
 Prompt for Price No  
 Tax Group State/County Tax  
 Selling Group ID N/A  
 Availability N/A  
 Commission Eligible Yes  
 Attached Items No  
 Fiscal Item ID N/A  
 Fiscal Item Description N/A

Previous
Next

- At the Item Prices page you can calculate the price of an item based on specified parameters, add a new price, or edit an existing price as needed.

**Figure 6-6 Item Prices Page**

Journal Reports Config Manager Data Management Deployment Support Tools System Management

Home > Data Manager > GROCERY.AT > Items > Merchandise Items > Item 514001 Prices

Calculate the price of an item based on the parameters below. You can also add a new price or edit an existing one in the list.

**514001**  
Cotton Draw-string Coral Short

Start Date: 2019-10-09

What type of price should be used?  
 Price  
(The lowest price out of REGULAR\_PRICE, PROMO\_PRICE and CLEARANCE\_PRICE)  
 Customer / Other Group Prices (Please select)

Quantity:

List Price N/A

Calculate

Your Price

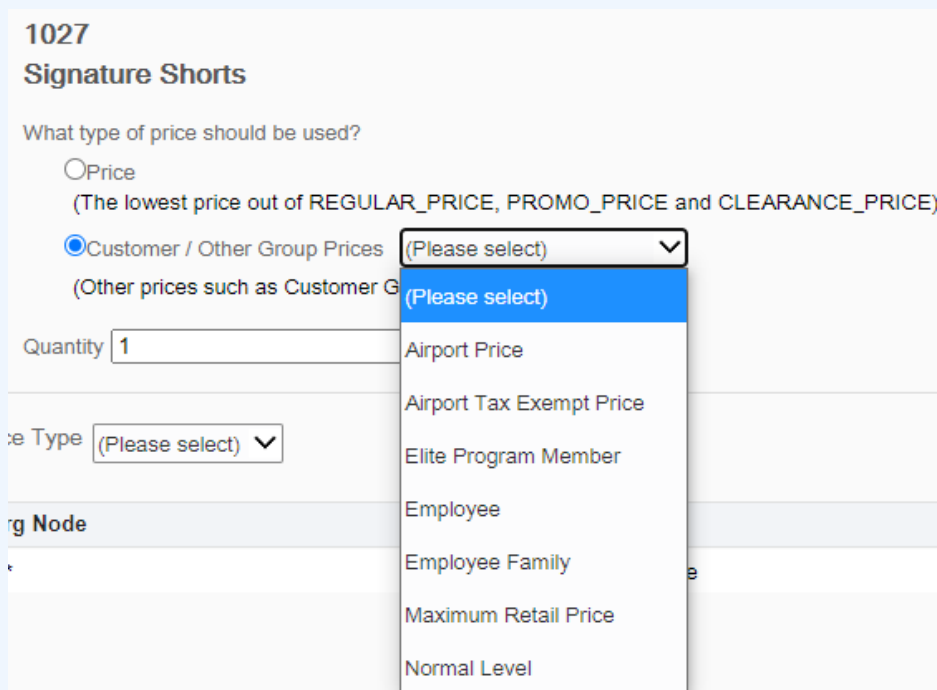
\$19.99

Price Type: (Please select)

Org Node	Price Type	Pricing Qty	Start Date	End Date
**	Regular Price	1	Jan 1, 1900	

 **Note:**


To quickly find an item price in the list at the Item Prices page, select the type of price from the Price Type filter list.




**1027**  
**Signature Shorts**

What type of price should be used?

Price  
(The lowest price out of REGULAR\_PRICE, PROMO\_PRICE and CLEARANCE\_PRICE)

Customer / Other Group Prices (Please select)   
(Other prices such as Customer Group)

Quantity

Price Type (Please select) 

Grouping Node

Price Type dropdown menu options:  
 (Please select)  
 Airport Price  
 Airport Tax Exempt Price  
 Elite Program Member  
 Employee  
 Employee Family  
 Maximum Retail Price  
 Normal Level

## Calculating the Price of an Item

Use this procedure to identify the exact price that exists for an item based on the type of price (regular price or a customer group), the pricing quantity, and date.

1. At the Item Prices page, enter the required information:
  - Price [REQUIRED] - What type of price should be used?
    - Price - The lowest price out of the regular price, promo price and clearance price.
    - Customer/Other Group Prices - Select from the list of available price types for the organization. For example, Airport Price, Airport Tax Exempt Price, Elite Program Member, Employee, Employee Family, Maximum Retail Price, Normal Level
  - Pricing Quantity [REQUIRED] - Enter the quantity of the item you are pricing.
  - Start Date [REQUIRED] when the price is in effect - Use the calendar to select the date for the item you are pricing.
2. Click **Calculate**. The system retrieves the pricing information:
  - If pricing information is found, the price for the item-based on the criteria you entered is displayed.

- If no pricing information is found, the "No Price Found" message displays. If you want to add pricing information, click the "No Price Found" link to open the Add Item Price window.

At the Add Item Price window, the parameters you

entered in the pricing search (Price Type, Pricing Qty, and Start Date) are populated automatically. See [Adding or Editing a Price](#) below for more information about adding/editing prices.

## Adding or Editing a Price

- At the Item Prices page, do one of the following:
  - To add a new price, click **Add New** and complete the fields as required.
  - To edit an existing price, click a row in list and edit the fields as needed.

**Figure 6-7 Item Price Window - Add New Price Example**

**Table 6-7 Add Item Price Fields**

Field	Description
Ord Node	This value cannot be changed.
Price Type [REQUIRED]	Select a price type from the drop-down list of available price types. This value cannot be changed in Edit mode.
Pricing Qty [REQUIRED]	Enter the pricing quantity for this item. This value cannot be changed in Edit mode.
Start Date [REQUIRED]	Enter/select the starting date for this price to be in effect. This value cannot be changed in Edit mode.
End Date	Enter/select the ending date when this price is no longer in effect.
Price [REQUIRED]	Enter the item price.

- Click **Save**.

## Attached Items

When viewing item information, if the selected item record is within your targeted org node and enabled for attached items, there is an option available to view and edit attached item information. You can edit attached items for your org node level only. See [Table 6-1](#) for attached item setup information.

1. At the Item Maintenance page, enter search criteria and select Search to find/edit an existing item in your organization.
2. At the Item search results list, select the item row from the list.

**Figure 6-8 Merchandise Items List Page - With Attached Items**

Item ID	Description	Department	Subdepartment	Class	Subclass
3010	Black/White Sleeveless Dress	25005			

3. Click **Attached Items** at the Item Information window to open the Attached Items page.

**Figure 6-9 Item Information Window - Attached Items Button**

**Item 3010**

Attached Items Prices Edit

**General Information**

Item ID 3010  
 Description Black/White Sleeveless Dress  
 Initial List Price None  
 Style ID N/A  
 Serialized Item No  
 Measurement Required No  
 Inventory Levels Tracked Yes  
 Department 25005 Subdepartment N/A  
 Class N/A Subclass N/A  
 Item UPCs None

**Selling Details**

Prompt for Description No  
 Prompt for Price No  
 Tax Group State/County Tax  
 Selling Group ID N/A  
 Availability N/A  
 Commission Eligible Yes  
 Attached Items Yes  
 Fiscal Item ID N/A  
 Fiscal Item Description N/A

Previous Next

4. The Attached Items page lists the existing attached items for the selected merchandise item.

Figure 6-10 Attached Items Page

ORACLE Xadmin 1000

Journal Reports Config Manager Data Management Deployment Support Tools System Management

Home > Data Manager > CORP.\* > Items > Merchandise Items > Item 3010 Attached Items

Enter the item ID of the attached item or search for it below.

Enter an item ID.

Add

Find an item to attach to the merchandise item.

Item ID  Equals

Description  Equals

Department  Equals  25005 - Womens

Subdepartment  Equals  (Please select)

Class  Equals  (Please select)

Subclass  Equals  (Please select)

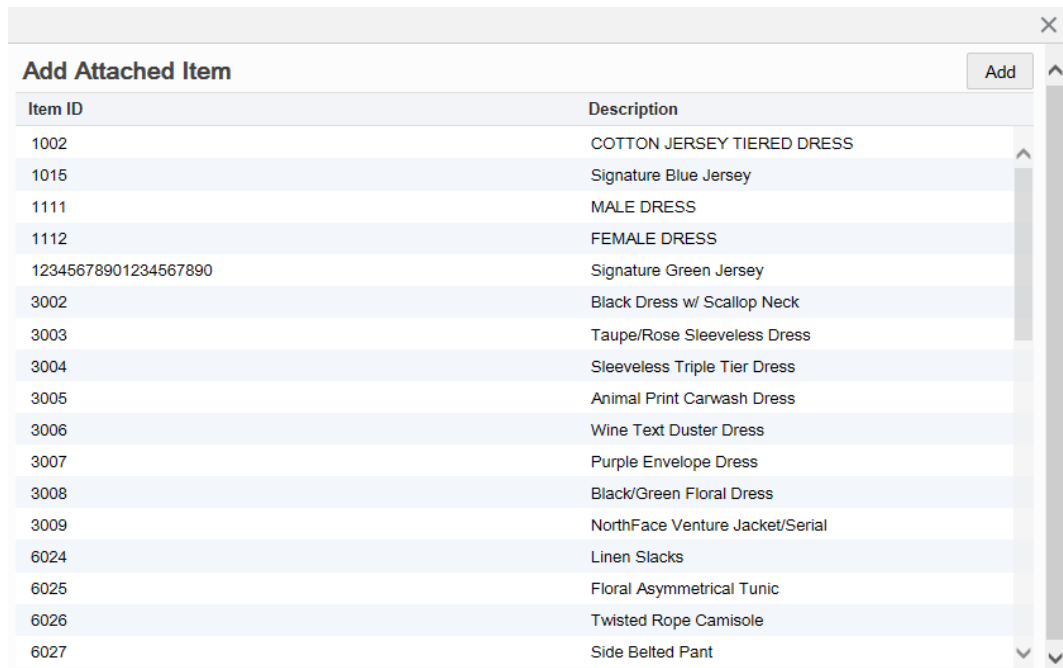
Search

Org Node	Item ID	Description	Start Date	End Date	Prompt to Add?
**	3006	Black/Green Floral Dress	Jan 1, 1900		
**	3007	Purple Envelope Dress	Jan 1, 1900		✓
**	3005	Animal Print Carwash Dress	Jan 1, 1900		✓

- To add an attached item to the sold item:
  - If you know the attached item ID, enter the item ID in the "Enter an item ID" field and click **Add**. Continue with step 2 on page 14.
  - If you do not know the item ID, enter search criteria and then click Search to find an item to attach to the merchandise item. Continue with To Add an Attached Item.
  - To edit an attached item, select the row you want to edit. Continue with To Edit an Attached Item.
  - To delete the relationship between the attached item and the sold item, click the Delete icon associated with the attached item and click Yes when prompted to confirm the deletion.

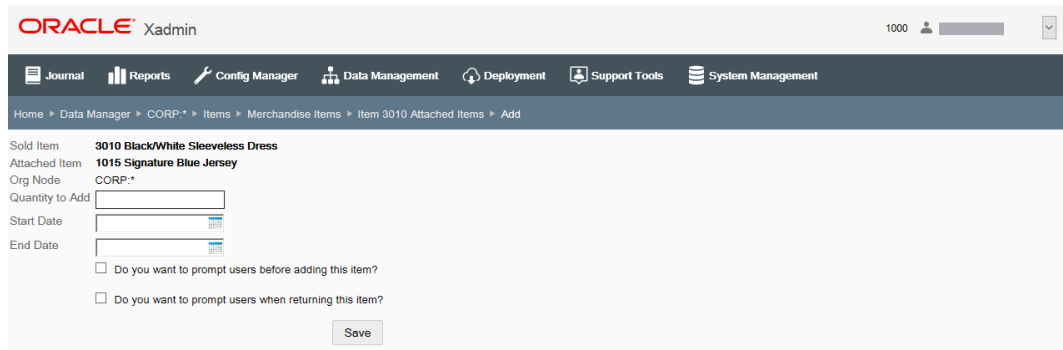
## Adding an Attached Item

1. At the Add Attached Item window, select the item and click **Add**.

**Figure 6-11 Add Attached Item Window**


Item ID	Description
1002	COTTON JERSEY TIERED DRESS
1015	Signature Blue Jersey
1111	MALE DRESS
1112	FEMALE DRESS
12345678901234567890	Signature Green Jersey
3002	Black Dress w/ Scallop Neck
3003	Taupe/Rose Sleeveless Dress
3004	Sleeveless Triple Tier Dress
3005	Animal Print Carwash Dress
3006	Wine Text Duster Dress
3007	Purple Envelope Dress
3008	Black/Green Floral Dress
3009	NorthFace Venture Jacket/Serial
6024	Linen Slacks
6025	Floral Asymmetrical Tunic
6026	Twisted Rope Camisole
6027	Side Belted Pant

2. Enter the attached item information.

**Figure 6-12 Item Information**


ORACLE Xadmin 1000

Journal Reports Config Manager Data Management Deployment Support Tools System Management

Home > Data Manager > CORP-\* > Items > Merchandise Items > Item 3010 Attached Items > Add

Sold Item **3010 Black/White Sleeveless Dress**  
 Attached Item **1015 Signature Blue Jersey**  
 Org Node **CORP-\***  
 Quantity to Add   
 Start Date   
 End Date

Do you want to prompt users before adding this item?  
 Do you want to prompt users when returning this item?

Save

- Sold Item - The merchandise item. [CANNOT BE CHANGED]
- Attached Item - The item attached to the merchandise item. [CANNOT BE CHANGED]
- Org Node - The org node that was targeted when the attached item relationship was originally made. [CANNOT BE CHANGED]
- Quantity to Add - [REQUIRED] The quantity of the item that is to be attached.
- Start Date - [REQUIRED] The starting date for this attached item.
- End Date - The ending date for this attached item.
- Do you want to prompt users before adding this item check box - Select to enable prompting.



- Do you want to prompt users when returning this item check box - Select to enable prompting.
3. Click **Save**. The system returns to the Attached Items page.

## Editing An Attached Item

1. After selecting the row you want to change, edit the attached item information.
  - Sold Item - The merchandise item. [CANNOT BE CHANGED]
  - Attached Item - The item attached to the merchandise item. [CANNOT BE CHANGED]
  - Org Node - The org node that was targeted when the attached item relationship was originally made. [CANNOT BE CHANGED]
  - Quantity to Add - [REQUIRED] The quantity of the item that is to be attached.
  - Start Date - [REQUIRED] The starting date for this attached item.
  - End Date - The ending date for this attached item.
  - Do you want to prompt users before adding this item check box - Select to enable prompting.
  - Do you want to prompt users when returning this item check box - Select to enable prompting.
2. Click **Save**. The system returns to the Attached Items page.

## Merchandise Hierarchy

...continued from [Items](#)

Select the **Merchandise Hierarchy** option ([Figure 6-3](#)) to view and configure the merchandise hierarchy for your organization.

**Figure 6-13 Merchandise Hierarchy Maintenance Page - Dept 300 Selected**

The screenshot displays the Oracle Xadmin interface for the Merchandise Hierarchy Maintenance page. The top navigation bar includes options like Journal, Reports, Config Manager, Data Management, Deployment, Support Tools, and System Management. The breadcrumb trail shows the path: Home > Data Manager > Items > Merchandise Hierarchy. The main content area is divided into two panes. The left pane, titled 'Merchandise Level Info', shows details for the selected node: Parent Level Root, Parent Value N/A, Level Department 300, and Value Footwear. An 'Edit' button is visible below this information. The right pane features a search box labeled 'Find a Node' and a tree view of the hierarchy. The tree view shows various nodes, with '300 - Footwear' highlighted in blue. Other nodes include 25000 - CAREER DRESS, 510 - Womens Moderate, 910 - Grocery, 400 - Technology, 730 - Mens Apparel, 25001 - SEASONAL, 740 - Shoes, 25002 - BEDDING, 25099 - GENERAL CLOTHES, 25003 - Jewelry, 25004 - Business Clothing, 350001 - Mens Shirts, 350002 - Womens Shirts, 350003 - Child Shirts, 350004 - Night Shirts, 25005 - Womens, 350 - Shirts, 630 - Food, SUPPLIES - Office Supplies, 25006 - ITM\_ATTR\_DEALS, and 810 - Pet Services.

The following information is shown on this page:

Merchandise Level Information - This area shows information about the selected level of the merchandise hierarchy, including the Parent Level and Value and the Item Level and Value.

If a level is inactive, it will be indicated as "Hidden".

Use the merchandise hierarchy tree to navigate and understand the hierarchy itself. (By default, the tree displays the Department level). When you select a merchandise hierarchy level in the tree view, the details of the level are displayed in the Merchandise Level Information panel.

Click **Edit** to update the merchandise level information displayed in the panel. See [Editing a Merchandise Hierarchy Level](#) below.

Action Panel - This area contains the link to add to an organization's organization hierarchy. The color legend shown here corresponds to the colors in the tree view for the merchandise hierarchy levels. To add new areas of a merchandise hierarchy, see [Adding to a Merchandise Hierarchy Level](#).

 **Note:**

You cannot add a new merchandise hierarchy level. Levels are restricted to what currently exists in your organization: Department, Subdepartment, Class, and so on.

## Editing a Merchandise Hierarchy Level

1. In the tree view, select the parent hierarchy level for the planned edit to the merchandise hierarchy.

 **Note:**

Use the "Find a Node" search box to quickly locate a node in the merchandise hierarchy tree.

2. With the node selected, click **Edit**.
3. Edit the information as needed:

Figure 6-14 Edit Merchandise Level

✕

### Edit Merchandise Level

Parent Level Root  
Parent Value N/A  
Level Department  
Hierarchy ID 300  
Description   
Display Order   
 Is this merchandise level visible?

- Parent Level - The parent merchandise hierarchy level. [CANNOT BE CHANGED]
- Parent Value - The parent merchandise hierarchy value. [CANNOT BE CHANGED]
- Level - The level type. (For example, if the parent level is a Department, then this level is Subdepartment based on the Merchandise Hierarchy setup shown here). [CANNOT BE CHANGED]
- Hierarchy ID - The identifier for the merchandise hierarchy level. [CANNOT BE CHANGED]
- Description - The description for the merchandise hierarchy level.
- Display Order - The display order for the merchandise hierarchy level.
- Is this merchandise level visible? check box - When selected, the merchandise level is active and visible. To deactivate the merchandise hierarchy level, remove the check mark from the check box. The deactivated level and all sublevels are grayed out on the page and a message displays in the Merchandise Level Information panel indicating that the level is hidden.

 **Note:**

If needed, click the Close icon to close the window without saving your changes. If prompted, click **Yes** to confirm you do not want to save any changes.

4. Click **Save** to close the window. The merchandise hierarchy level is updated as specified.

## Adding to a Merchandise Hierarchy Level

1. In the tree view, select the parent hierarchy level for the planned addition to the merchandise hierarchy.

 **Note:**





Use the "Find a Node" search box to quickly locate a node in the merchandise hierarchy tree.

2. With the node selected, click the link - add a level to the currently selected node.

**Figure 6-15 Add a Level Link**

If a merchandise hierarchy level needs to be added, you can [add a level to the currently selected node](#).

Legend

-  Department
-  Subdepartment
-  Class
-  Subclass

3. Enter the information for the new level:

**Figure 6-16 Add Merchandise Level**

×

### Add Merchandise Level

Parent Level	Department
Parent Value	300 Footwear
Level	Subdepartment
Hierarchy ID	<input type="text"/>
Description	<input type="text"/>
Display Order	<input type="text"/>
<input checked="" type="checkbox"/> Is this merchandise level visible?	

- Parent Level - The parent merchandise hierarchy level. [CANNOT BE CHANGED]
- Parent Value - The parent merchandise hierarchy value. [CANNOT BE CHANGED]
- Level - The level type to be created. (For example, if the parent level is a Department, then this level is Subdepartment based on the Merchandise Hierarchy setup shown here). [CANNOT BE CHANGED]
- Hierarchy ID - The identifier for the new merchandise hierarchy level. [REQUIRED]
- Description - The description for the new merchandise hierarchy level. [REQUIRED]
- Display Order - The display order for the new merchandise hierarchy level.
- **Is this merchandise level visible? check box** - When selected, the merchandise level is active and visible. To deactivate the merchandise hierarchy level, remove the check mark from the check box. The deactivated level and all sublevels are grayed out on the page and a message displays in the Merchandise Level Information panel indicating that the level is hidden.

 **Note:**

If needed, click the Close icon to close the window without saving your changes. When prompted, click Yes to confirm you do not want to save any changes.

4. Click **Save** to close the window. The new merchandise hierarchy level is added to the tree.

## Non-Merchandise Items

...continued from [Items](#)

Select the **Non-Merchandise Items** option ([Figure 6-3](#)) to view and configure the merchandise hierarchy for your organization. The Non-Merchandise Items Maintenance page displays all non-merchandise items available to the targeted org node.

Figure 6-17 Non-Merchandise Items Maintenance Page

Item ID	Description	Type Code	Subtype Code
124	Order Deposit	Order Deposit	Deposit
125	Order Payment	Order Payment	Payment
1500	\$100 Gift Card	Voucher	Gift Card
1501	\$50 Gift Card	Voucher	Gift Card
1502	\$25 Gift Card	Voucher	Gift Card
1503	\$10 Gift Card	Voucher	Gift Card
1504	Gift Card	Voucher	Gift Card
1505	Reload Gift Card	Voucher	Gift Card
1700	Loyalty Card Purchase	Loyalty Card	Loyalty Purchase
1701	Loyalty Card Renewal	Loyalty Card	Loyalty Renewal
2003	\$5 Xstore Gift Certificate	Voucher	Gift Certificate
2004	Send Sale Shipping Fee	DISPLAY	
2005	Restocking Fee	Restocking Fee	Fee
2006	Gift Wrapping	GIFT_WRAP	
2007	Item Alteration	ALTERATIONS	
2008	Item Repair	REPAIR	
2009	House Account Payment	Accounts Receivable Payment	Payment
2010	House Account Reversal	House Account Reversal	
2011	Core Charge	FEE	Fee
2013	Prepaid advertisement 1 description	REPLENISHMENT	PRE_PAID_ADVERTISING
2103	\$10 Xstore Gift Certificate	Voucher	Gift Certificate
2104	\$25 Xstore Gift Certificate	Voucher	Gift Certificate
2105	\$50 Xstore Gift Certificate	Voucher	Gift Certificate
2106	\$75 Xstore Gift Certificate	Voucher	Gift Certificate
5000	Work Order Deposit	Work Order Deposit	Deposit
5001	Replace Bezel	Work Order	TASK

**Note:**

Use the Subtype Code filter to find non-merchandise items within the list of non-merchandise items.

If adding a new non-merchandise item:

At the Non-Merchandise Items Maintenance page, click **Add New** to create a new item.

If editing an existing item:

At the Non-Merchandise Items Maintenance page, select the row from the non-merchandise items list and click **Edit** at the item information window.

**Note:**

To view and/or edit item prices, refer to [Item Prices](#), step 2, for procedural information.

See step 6 for additional procedural information.

The following Non-Merchandise Item Maintenance fields are available:

**Table 6-8 Basic Non-Merchandise Information**

Field	Description
Item ID [REQUIRED]	Enter the item identifier. This field cannot be edited for existing items.
Description [REQUIRED]	Enter the item description.
Prompt for Description check box	Select this check box if the item description must be manually entered when this item is sold.
Tax Group [REQUIRED]	Select the item's tax group from the drop- down list. Possible values are from the Tax Group table (tax_tax_group).
Availability	Select the product availability to determine whether or not an item is available for sale: Available, Not Sellable at POS, or Recalled.
Commission check box	If applicable, select this option if the item qualifies for commission.
Serial Number check box	Select this option if a serial number is required.

**Table 6-9 Quantity Attributes**

Field	Description
Sale Quantity check box	Select this option if the item quantity cannot be changed from 1. <b>Note:</b> This option will disable all other item quantity options listed here.
Quantity Prompt check box	Select this option if the item quantity must be manually entered when this item is sold.
Initial Sale Quantity check box	Select this option if the item is sold in a quantity other than one. If selected, enter the initial quantity at which this item must be sold.
Maximum Sale Quantity check box	Select this option if the item has a maximum sale quantity. If selected, enter the maximum quantity of this item that may be sold in a single transaction.
Customer Information Required check box	Select this option if the system prompts for customer information when the item is sold. If selected, a prompt for information will be displayed. Select whether the information is required or optional: Prompt, entry is required Prompt, entry is optional
Purchaser Minimum Age Required check box	Select this option if a minimum age is required to purchase the item. If selected, enter the minimum age (in years) required to purchase the item.

**Table 6-10 Item Restriction Attributes**

Field	Description
Inventoried check box	Select this option if inventory levels are tracked for this item.
Item Type Restrictions:	
Disallow Layaway check box	Select this option if this item cannot be added to a layaway transaction type.

**Table 6-10 (Cont.) Item Restriction Attributes**

Field	Description
Disallow Order check box	Select this option if item cannot be ordered via Oracle Retail Order Broker Cloud Service Order functionality.
Disallow Returns check box	Select this option if this item cannot be added to a return transaction type.
Disallow Send Sale check box	Select this option if this item cannot be added to a send sale transaction type.
Disallow Special Order check box	Select this option if this item cannot be added to a special order transaction type.
Disallow Work Order check box	Select this option if this item cannot be added to a work order transaction type.
Price Change Restrictions:	
Disallow Deal check box	Select this option if this item does not qualify for deals.
Disallow Discount check box	Select this option if this item cannot be discounted.
Disallow Price Change check box	Select this option if this item price cannot be changed.

**Table 6-11 Specific Non-Merchandise Item Attributes**

Field	Description
Type Code [REQUIRED]	Select the type code for the non-merchandise item. If needed, select Other to create a new type code and enter new type code in the Type Code field. <b>Note:</b> A new type code created here will only be for this non-merchandise item and will not be available for any other items.
Subtype Code [REQUIRED]	Select the subtype code for the non-merchandise item.
Exclude From Net Sales check box	Select this option if the non-merchandise item will not be attributed as revenue.
Prompt for Price check box	Select this option if the retail price must be manually entered when this item is sold.

## Item Matrix Manager

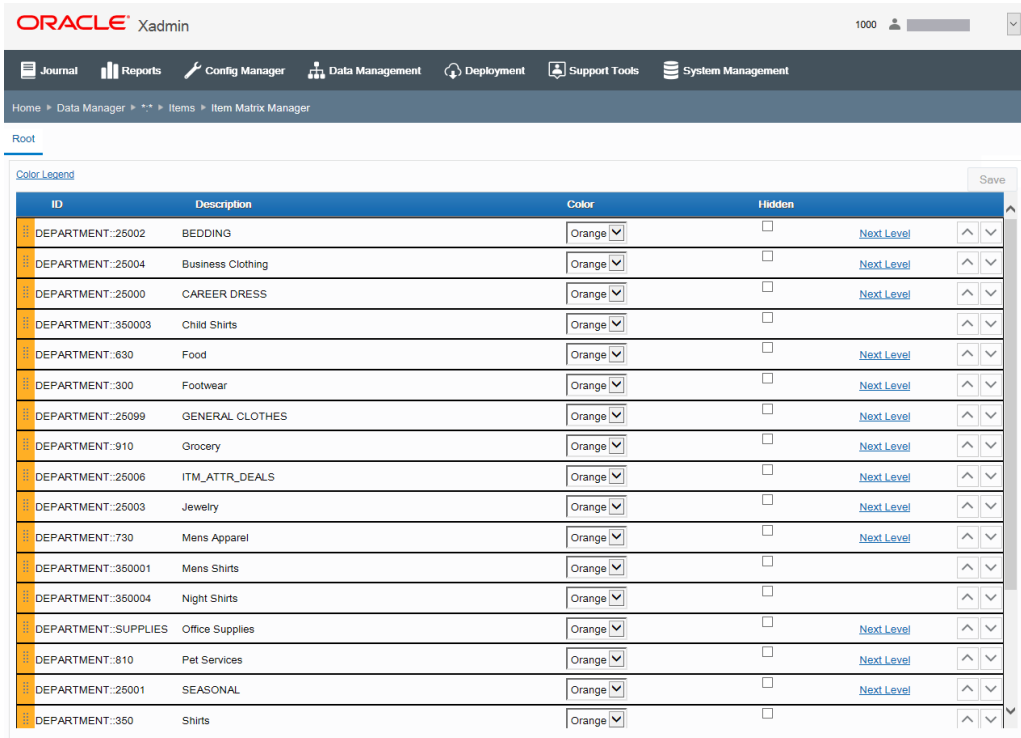
...continued from [Items](#)

Select the **Item Matrix Manager** option ([Figure 6-3](#)) to manage the item matrix information for your organization.


At the Item Matrix Manager page, manage the look and feel of the item matrix in Oracle Retail Xstore Point of Service. Use this feature to assign matrix colors to merchandise hierarchy and/or item records, mark merchandise hierarchy and/or item records as hidden (items labeled as hidden will not show in the item matrix in Oracle Retail Xstore Point of Service), and change the sort order of merchandise hierarchy and/or item records to specify how they will display within the item matrix in Oracle Retail Xstore Point of Service.



**Figure 6-18** Item Matrix Manager Page



**Table 6-12** Fields on the Item Matrix Screen

Field	Description
 Color Area	Shows the color currently associated with the merchandise hierarchy or item and is used to drag and drop the selection to another location in the list.
ID	The merchandise hierarchy or item identifier.
Description	The merchandise hierarchy or item description.
Color	The color associated with the merchandise hierarchy or item for display in the item matrix in Oracle Retail Xstore Point of Service.
Hidden	If the check box is selected, the merchandise hierarchy or item will not show in the item matrix in Oracle Retail Xstore Point of Service.

**Table 6-13** Links and Buttons the Item Matrix Screen

Link	Description
Color Legend	Opens a window showing the available color palette. The link is not available for screen readers.
Next Level	Opens a new page showing the items in next merchandise hierarchy level.
Move Up and Move Down Arrow buttons	Change the sort order of the displayed list.

## Assigning Matrix Colors To Merchandise Hierarchy And/Or Item Records

1. Select a color from the Color drop-down list for the merchandise hierarchy or item record you want to change.

The color in the Color Area associated with the item is changed to the selected color.

### Note:

To view the available colors, click the Color Legend link.

The color Gray shown in the legend is not available from the drop-down list of available colors. Gray is used to denote "Hidden" buttons only.



2. Click **Save** to save your changes.

## Changing the Sort Order

There are two ways to change the sort order of the items:

Drag and Drop:

1. Hover over the shaded area of the row you want to move.
2. With the move icon showing for the selected item row, drag and drop the item to a new location in the list to change the sort order.
3. Click **Save** to save your changes.

Move Up and Down Arrow buttons:

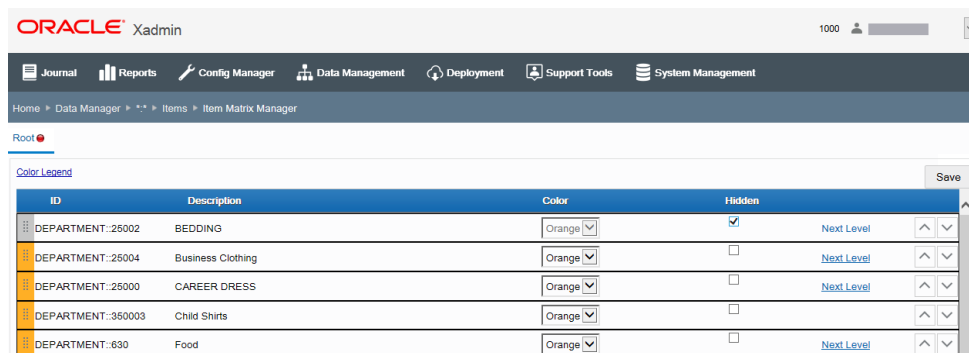
1. Select the row you want to move.
2. Use the **Move Up** and **Move Down** Arrow buttons of the selected row to change the sort order in the list.

3. Click **Save** to save your changes.

## Specifying Merchandise Hierarchy And/Or Item Records As Hidden

1. Click the Hidden check box for the merchandise hierarchy or item record.

**Figure 6-19 Hidden Check Box Selected**



ID	Description	Color	Hidden	Next Level
DEPARTMENT:26002	BEDDING	Orange	<input checked="" type="checkbox"/>	Next Level
DEPARTMENT:26004	Business Clothing	Orange	<input type="checkbox"/>	Next Level
DEPARTMENT:25000	CAREER DRESS	Orange	<input type="checkbox"/>	Next Level
DEPARTMENT:360003	Child Shirts	Orange	<input type="checkbox"/>	Next Level
DEPARTMENT:630	Food	Orange	<input type="checkbox"/>	Next Level

When the Hidden check box is selected, the color drop-down list and the Next Level link are no longer available for selection. In addition, the color in the shaded area associated with the item is changed to gray.

2. Click **Save** to save your changes.

## Item Message Maintenance

...continued from [Items](#)

The **Item Message Maintenance** option ([Figure 6-3](#)) allows you to add, edit or delete a message to/from a number of items. The message is then displayed in the Info tab in the Xstore POS during a sale transaction.

### Note:

Only one message per item is displayed in the Info tab in the Xstore POS. If you want to display multiple messages per item you need to enable the `DisplayMessageAsNotify` configuration in the database.

To add messages for a large number of items, use the `DataLoader`. For more information about the `DataLoader`, see the *Oracle Retail Xstore Point of Service Host Interface Guide*.

There are four message types that can be displayed in the Xstore POS Info tab:

- Text messages
- HTML messages - HTML messages may include graphics and text.
- Titled image messages - Titled image messages contain an image along with a title.

- Composite messages - Composite messages include graphics and text. The image and text message are displayed together in the Info tab.

**Figure 6-20 Item Message Maintenance**

ORACLE Xadmin 1000

Journal Reports Config Manager Data Management Deployment Support Tools System Management

Home > Data Manager > \*\* > Items

Select one of the following options.

- > **Merchandise Hierarchy**  
View and configure the merchandise hierarchy for your organization.
- > **Merchandise Items**  
Create and maintain merchandise Items for your organization.
- > **Non-Merchandise Items**  
Create and maintain non-merchandise items for your organization.
- > **Item Matrix Manager**  
Manage the content of the item matrix.
- > **Item Message Maintenance**  
Create and maintain item messages for your organization.

Create a new message.

Find a message.

Message ID

Message Title

## Adding an Item Message

To add an item message:

1. Click **Add New**. The Edit Item Message page appears.
2. Select one of the following message types from the list:
  - Text
  - HTML
  - Composite
  - Titled Image

### Note:

If an item has more than one message type, the message types are display in the following order:

- a. Composite
- b. Text
- c. HTML
- d. Titled Image

3. Depending on the selected message type, enter the following fields:

**Figure 6-21 Edit Item Message Window**

**Table 6-14 Item Messages Fields**

Field	Description
Message ID [REQUIRED]	Enter a message ID.
Message Text [REQUIRED]	Enter a message text.
Message Title	Enter a message title.
Message HTML File	<p>Only available for message type HTML</p> <p>To upload a file:</p> <ul style="list-style-type: none"> <li>Click <b>Browse</b> to select the HTML file you want to upload.</li> <li>The file name is displayed with a Delete link next to it.</li> <li>If you want to remove the message file, select the Delete link.</li> </ul> <p><b>Note:</b> You can only upload one HTML file per message.</p>
Message HTML	<p>Only available for message type HTML</p> <p>Enter the message in HTML format. ?</p>

**Table 6-14 (Cont.) Item Messages Fields**

Field	Description
Image	<p>Only available for message type Composite and Titled Image</p> <p>You can upload the following file formats.png, .jpg, and .gif</p> <p>To upload an image file:</p> <ul style="list-style-type: none"> <li>• Click <b>Browse</b> to select the file you want to upload.</li> <li>• The file name is displayed with a Delete link next to it.</li> <li>• If you want to remove the image file, select the Delete link.</li> </ul> <p><b>Note:</b> You can only upload one image file per message.</p>
Effective Date	Enter or use the Calendar icon to select an effective date for the message.
Expiry Date	Enter or use the Calendar icon to select an expiry Date for the message.
Item ID	<p>To add an item to the message:</p> <ul style="list-style-type: none"> <li>• In the Item ID field, enter the item ID to which you want to add the message.</li> <li>• Click the <b>Add</b> link next to the Item ID field.</li> <li>• The item ID is displayed below the Item ID field.</li> </ul> <p>To delete the item from the message:</p> <ul style="list-style-type: none"> <li>• Click the <b>Delete</b> link next to the item ID.</li> <li>• The item is removed.</li> </ul>

4. Click **Save** to save the message for the selected items.

## Editing an Item Message

To edit an item message:

1. Enter search criteria and click **Search** to find/edit an item message. If you do not enter any criteria before selecting **Search**, all item messages will be displayed in the Search Results page.
2. To edit information for an existing message, select the row from the search results list and edit the information as needed. You can also create a new message by clicking **Add New** at the Search Results page.
3. Complete the fields as required, then click **Save**.

### Note:

To delete an existing message, click the Delete icon associated with the record at the search results list. When prompted, click **Yes** to confirm the deletion.

See step 6 for additional procedural information.

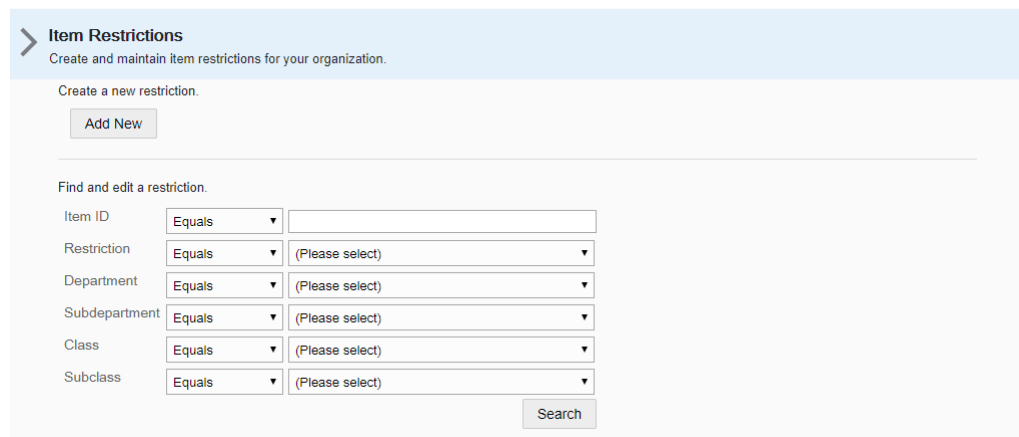
## Item Restrictions

...continued from [Items](#)

Select the **Item Restrictions** option ([Figure 6-3](#)) to add and/or edit item restrictions.

 **Note:**

You need to create at least one item restriction, before you can define item restrictions types. For more information on item restriction types, see the [Item Restriction Types](#) section.

**Figure 6-22 Item Restrictions Maintenance**


**Item Restrictions**  
Create and maintain item restrictions for your organization.

Create a new restriction.

---

Find and edit a restriction.

Item ID

Restriction

Department

Subdepartment

Class

Subclass

## Adding an Item Restriction

To add an item restriction:

1. Click **Add New**. The Edit Restriction page appears.
2. In the Define tab, enter the following information:
  - Restriction ID [REQUIRED]- Enter the ID for the item restriction.
  - Description [REQUIRED] - Enter a short description for the item restriction.
3. Then click **Next** to open the Associate tab.
4. In the Associate tab, select or enter the merchandise hierarchy information for the item restriction.
  - Select the desired merchandise level from the list:

**Table 6-15 Merchandise Level Fields - Associate Tab**

Field	Description
Department	Select the item's department from the drop-down list.
Subdepartment	Select the item's subdepartment from the drop-down list.
Class	Select the item's class from the drop-down list.
Subclass	Select the item's subclass from the drop-down list.

- Then click the **Add** link, to add the merchandise hierarchy level to the list below the entry fields.

- and/or go to the Item ID field and enter the item ID for the restriction.
  - Then select the **Add** link, to add the item to the list.

 **Note:**

To delete a merchandise hierarchy or item from the restriction, click the Delete (X) icon associated with the record at the list. When prompted, click **Yes** to confirm the deletion.

5. Click **Next** to open the Review tab.
6. Review your entries and click **Save** to save the item restriction.

## Editing an Item Restriction

To edit an item restriction:

1. Enter search criteria and click **Search** to find/edit an item restriction. If you do not enter any criteria before selecting **Search**, all item restrictions will be displayed in the Search Results page.
2. To edit information for an existing restriction, select the row from the search results list. The Item Restriction window appears.

 **Note:**

You can also create a new item restriction by clicking **Add New** at the Search Results page.

3. Click **Edit**. The Edit Item Restriction page opens.
4. Complete the fields in the tabs as required, then click **Save**.

 **Note:**

To delete an existing restriction, click the Delete (X) icon associated with the record at the search results list. When prompted, click **Yes** to confirm the deletion.

See step 6 for additional procedural information.

## Item Restriction Types

...continued from [Items](#)

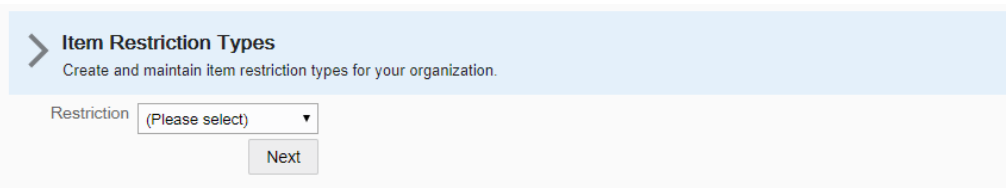


 **Note:**

You need to create at least one item restriction, before you can define item restrictions types. For more information on item restriction types, see the [Item Restriction Types](#) section.

Select the **Item Restrictions Types** option ([Figure 6-3](#)) to create item restrictions for the days and time frame in which certain items are sold. You can also configure the minimum required customer age to purchase an item, and the minimum required cashier age to sell an item.

**Figure 6-23 Item Restriction Types**



## Searching for Item Restriction Types

To search for an item restriction type:

1. In the Item Restriction Type section, select the Restriction from the list.
2. Then click **Next**. The Item Restriction Type Search Results are displayed.

In the Search Results page you can:

- Add an item restriction type. For more information, see [Adding Item Restriction Types](#).
- Edit an item restriction type. For more information, see [Editing an Item Restriction](#)

## Adding Item Restriction Types

To add an item restriction type:

1. Click **Add New**. The Edit Restriction Type page appears.
2. In the Define tab, enter the following information:

**Table 6-16 Item Restriction Type - Define Tab**

Field	Description
Restriction [REQUIRED]	Select the restriction.
Restriction ID [REQUIRED]	Select restriction ID.
Effective Date [REQUIRED]	Enter an effective date or use the Calendar icon to select a date.

**Table 6-16 (Cont.) Item Restriction Type - Define Tab**

Field	Description
Expiration Date [REQUIRED]	Enter an expiration date or use the Calendar icon to select a date.
Is this restriction type excluded during returns? check box	If you want to exclude this restriction types for returns, select the check box.

3. Then click **Next** to open the Restriction Type tab.
4. Depending on the selected Restriction Type in the Define tab, complete the fields as following:
  - If you selected Minimum Customer Age, enter the minimum required customer age to purchase the item(s).
  - If you selected Minimum Cashier Age, enter the minimum required cashier age to sell the item(s).
  - If you selected Day Restriction, select a day check box. Then enter a start and end time to define the restriction period.

**Figure 6-24 Day Restriction**

This page is used to maintain restriction information specific for the item restriction type.

Are there specific days and timeframes in which this restriction should be applied?

<input type="checkbox"/>	Sunday	Enter time	To	Enter time
<input type="checkbox"/>	Monday	Enter time	To	Enter time
<input type="checkbox"/>	Tuesday	Enter time	To	Enter time
<input type="checkbox"/>	Wednesday	Enter time	To	Enter time
<input type="checkbox"/>	Thursday	Enter time	To	Enter time
<input type="checkbox"/>	Friday	Enter time	To	Enter time
<input type="checkbox"/>	Saturday	Enter time	To	Enter time

5. Click **Next** to open the Review tab.
6. Review your entries and click **Save** to save the item restriction type.

## Editing Item Restriction Types

To edit an item restriction type:

1. To edit information for an existing restriction type, select the row from the search results list. The Item Restriction Types window opens.
2. Click **Edit**. The Edit Item Restriction Types page opens.
3. Complete the fields in the tabs as required, then click **Save**.

 **Note:**

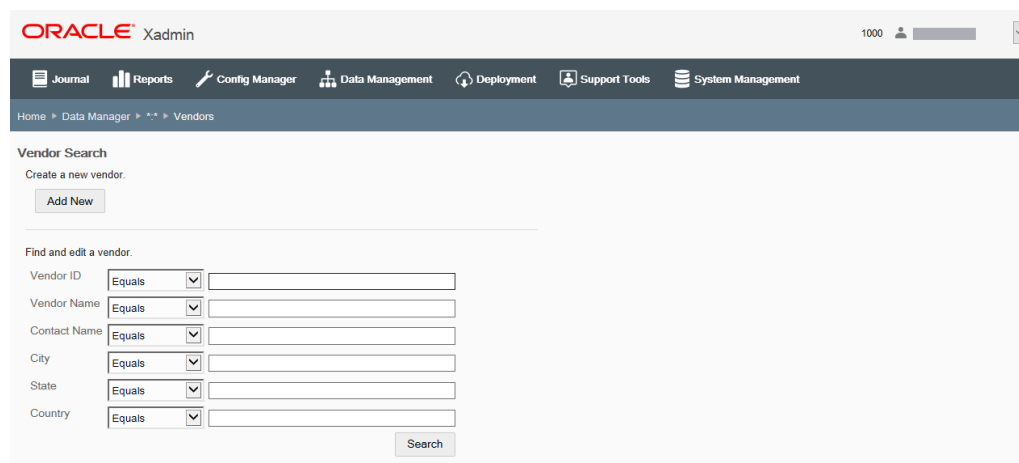
To delete an existing restriction type, click the Delete (X) icon associated with the record at the search results list. When prompted, click **Yes** to confirm the deletion.

See step 6 for additional procedural information.

## Vendors

Use this feature to create and modify vendors for your organization.

**Figure 6-25 Vendor Maintenance Page**



The screenshot shows the Oracle Xadmin interface for Vendor Maintenance. At the top, there is a navigation bar with icons for Journal, Reports, Config Manager, Data Management, Deployment, Support Tools, and System Management. Below this is a breadcrumb trail: Home > Data Manager > Vendors. The main content area is titled "Vendor Search" and includes a sub-header "Create a new vendor." with an "Add New" button. Below that, there is a section titled "Find and edit a vendor." which contains a search form. The form has six rows, each with a dropdown menu set to "Equals" and a text input field. The rows are labeled: Vendor ID, Vendor Name, Contact Name, City, State, and Country. A "Search" button is located at the bottom right of the form.

If adding a new vendor:

At the Vendor Maintenance page, click **Add New** to create a new vendor.

If editing an existing vendor:

Enter search criteria and click **Search** to find/edit a vendor in your organization. If you do not enter any criteria before selecting **Search**, all vendors in your organization will be returned in the search. To edit information for an existing vendor, select the row from the search results list and click **Edit** at the vendor information screen.

**Note:**

To delete an existing vendor, click the **Delete** icon associated with the record at the search results list.

See step 6 for additional procedural information.

Complete the following Vendor Maintenance fields, then click **Save**.

**Table 6-17 Basic Vendor Attributes**

Field	Description
Vendor ID [REQUIRED]	Enter a unique identifier assigned to a vendor. This value cannot be changed in Edit mode.
Vendor Name [REQUIRED]	Enter the name of the vendor.
Contact Name	Enter the primary contact person for the vendor.
Contact Telephone	Enter the primary telephone number of the primary contact.
Buyer Name	Enter the name of the buyer associated with the vendor.

**Table 6-18 Vendor Address Attributes**

Field	Description
Address 1	Enter the first line of the mailing address.
Address 2	Enter the second line of the mailing address.
City	Enter the city component of the mailing address.
State	Enter the State/Province component of the mailing address.
Postal Code	Enter the Postal or ZIP code component of the mailing address.
Country	Enter the country component of the address.
Vendor Telephone	Enter the primary telephone number.

## Employees

Use this feature to create and modify employee records for your organization.

**Figure 6-26 Employee Maintenance Page**

If adding a new employee record:

At the Employee Maintenance page, click **Add New** to create a new employee record.

If editing an existing employee record:

Enter search criteria and click **Search** to find/edit an existing employee record in your organization. If you do not enter any criteria before selecting Search, all employee records in your organization will be returned in the search. To edit information for an existing employee record, select the row from the search results list and click Edit at the employee information screen.



#### Note:

To delete an existing employee record, click the Delete icon associated with the record at the search results list.

See step 6 for additional procedural information.

The following Employee Record Maintenance fields are available:

**Table 6-19 Basic Employee Attributes**

Field	Description
Employee ID [REQUIRED]	Enter the unique number used to identify a store employee. This field cannot be changed in edit mode.
Login ID	If used, enter the employee's user ID for logging in to the system. (Only displayed if Oracle Retail Xstore Point of Service is configured to use a Login ID.)
First Name [REQUIRED]	Enter the employee's first name.
Middle Name	Enter the employee's middle name.
Last Name [REQUIRED]	Enter the employee's last name. <b>Note:</b> Select a suffix from the drop-down list if applicable.
Language	Select the employee's preferred language.

**Table 6-19 (Cont.) Basic Employee Attributes**

Field	Description
Gender	Select the employee's gender, Male or Female.
Employment Status	Select the employee's status: Active, Inactive, Terminated. <b>Note:</b> If Terminated status is selected, the termination date is required. Enter the termination date in the Termination Date field.
Activation Date	Enter the date on which the employee became active.

**Table 6-20 Detailed HR Information Attributes**

Field	Description
Job Title	Enter the employee's job title.
Birth Date	Enter the employee's date of birth.
Base Pay	Enter the employee's base pay.
Pay Status	Select the employee's pay status; hourly or salaried.
Hire Date	Enter the date the employee was hired.
Last Review	Enter the date of the employee's last review.
Next Review	Enter the date of the employee's next review.
Extra Withholding check box	Select this option if the employee wants to have extra money withheld from his/her pay. Type the dollar amount to be withheld in the Amount field.
Overtime Eligible check box	Select this option if the employee is eligible for overtime.
Clock In Required check box	Select this option if the employee is required to clock in and out.

**Table 6-21 Contact Information**

Field	Description
Address 1	Enter the first line of the mailing address.
Address 2	Enter the second line of the mailing address.
City	Enter the city component of the mailing address.
State	Enter the State/Province component of the mailing address.
Postal Code	Enter the Postal or ZIP code component of the mailing address.
Country	Enter the country component of the address.
Primary Phone	Enter the employee's primary phone number.
Other Phone	Enter the employee's alternate phone number.
Email	Enter the employee's email address.
Emergency Contact	Enter the name of an emergency contact for the employee.
Emergency Phone	Enter the phone number of the emergency contact for the employee.

**Table 6-22 Oracle Retail Xstore Point of Service Security Attributes**

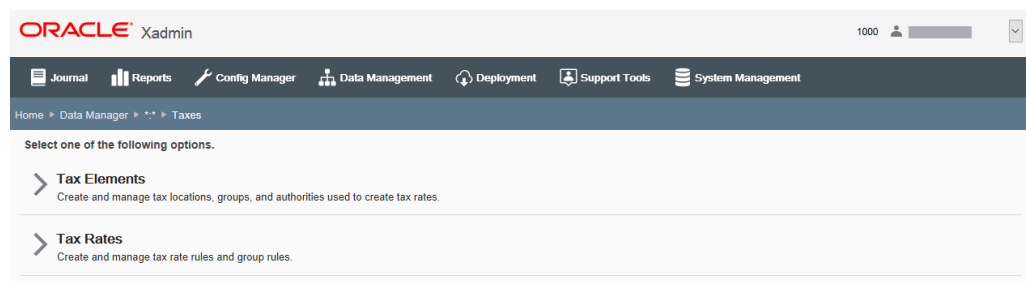
Field	Description
Primary Security Group [REQUIRED]	Select the fundamental security group to which this employee belongs.
Security Groups check box	Select any other security groups to which this employee belongs: Trainee, Cashier, Keyholder, Manager. Select all that apply. By default, the "Everyone" security group is required for all employees. This value cannot be changed.
Customer Groups check box	Select the customer groups to which this employee belongs. Select all that apply.

**Table 6-23 Assigned Stores Attributes**

Field	Description
Store #	Enter the specific retail store within the organization the employee is assigned to.
Start Date	Enter the date the employee assignment begins at the store. Click <b>Add Store</b> to assign the employee to this store on the start date. Add as many stores/start dates as needed. <b>Note:</b> Click <b>Add All Stores</b> to assign the employee to all stores in the organization. The store information is added to the screen. Repeat until all stores where the employee works are listed. If needed, click <b>Delete</b> to remove an assigned store..
Temporary Assignment check box	Select this option if the assignment is temporary. Enter the ending date for this temporary assignment.

## Taxes

Use this feature to manage tax configurations for your organization.

**Figure 6-27 Data Manager - Taxes Page**

- To set up and manage Tax Authorities, Tax Locations, Tax Brackets, and Tax Groups used to create the tax rates, click Tax Elements. See [Tax Elements](#) below.
- To set up and manage Tax Rates, click Tax Rates. See [Tax Rates](#).

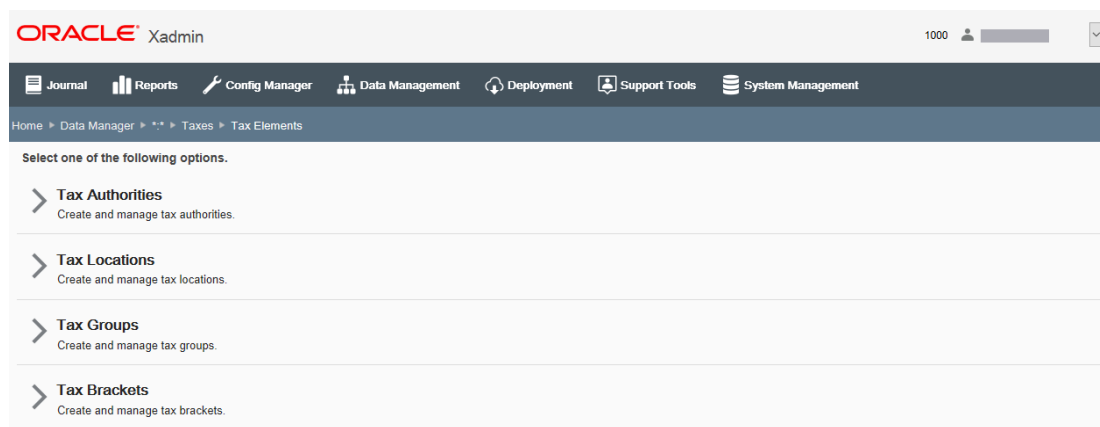
 **Note:**

The Tax Elements must be set up before you can set up the Tax Rates.

## Tax Elements

Set up the basic tax elements here before setting up the tax rate rules.

**Figure 6-28 Tax Elements Page**



- **Tax Authorities** - Identifies the name of the authority that imposes the tax, and also supplies the rounding rules that are used in the calculation. See [Tax Authorities](#).
- **Tax Locations** - Defines the tax locations that can be assigned to individual stores. See [Tax Locations](#)
- **Tax Groups** - Defines tax groups for items that are taxed according to the same rules. For example, certain food products may belong to the same tax group. After defining the tax groups, they may be assigned to individual items. See [Tax Groups](#).
- **Tax Brackets** - Defines the tax brackets used to calculate the sales tax for an item or transaction. See [Tax Brackets](#).

## Tax Authorities

If adding a new tax authority:

1. At the Tax Authorities Maintenance page, click **Add New** to create a new tax authority.
2. Complete the fields as required, then click **Save**.

If editing an existing tax authority:

1. At the Tax Authorities Maintenance page, select a tax authority from the list of tax authorities that are currently available for the targeted org node.
2. Edit the fields as required, then click **Save**. The following Tax Authority fields are available:



**Table 6-24 Tax Authorities Fields**

Field	Description
ID [REQUIRED]	Enter a unique identifier of a tax authority. The ID cannot be changed in edit mode.
Name [REQUIRED]	Enter the name of the tax authority.
Rounding Code	Select from the drop-down list of rounding codes. Codes indicate how tax is to be rounded when calculated. The list is populated using <code>TaxAuthorityUiContainer</code> . Values: Always round down Always round up Round ceiling Round floor Round half down Round half even Round half up
Rounding Digits	Enter the number of digits to which rounding is to be calculated.

## Tax Locations

If adding a new tax location:

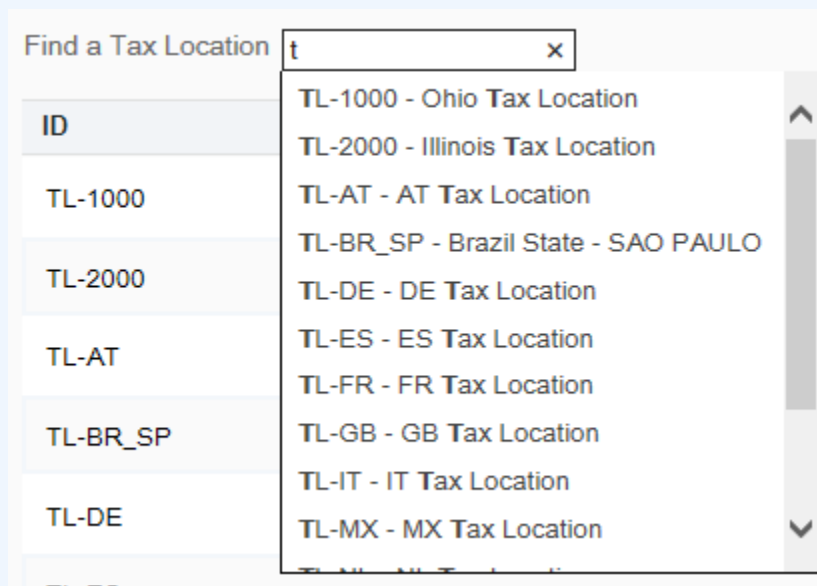
1. At the Tax Locations Maintenance page, click **Add New** to create a new tax location.
2. Complete the fields as required, then click **Save**.

If editing an existing tax location:

1. At the Tax Locations Maintenance page, select a tax location from the list.
2. Edit the fields as required, then click **Save**.

 **Note:**

To search for a specific tax location, begin typing the tax location description in the Find a Tax Location field.



The following Tax Location fields are available:

**Table 6-25 Tax Location Fields**

Field	Description
ID [REQUIRED]	Enter a unique identifier of a tax location. The ID cannot be changed in edit mode.
Name [REQUIRED]	Enter the name of the tax location.
Description	Enter a text description of the tax location.

 **Note:**

Any Tax Locations created here will be "pending deployment"; however, these locations will be available for use within the other areas of the Taxes feature.

## Tax Groups

If adding a new tax group:

1. At the Tax Groups Maintenance page, click **Add New** to create a new tax group.
2. Complete the fields as required, then click **Save**.

If editing an existing tax group:

1. At the Tax Groups Maintenance page, select a tax group from the list.
2. Edit the fields as required, then click **Save**. The following Tax Group fields are available:

**Table 6-26 Tax Group Fields**

Field	Description
ID [REQUIRED]	Enter a unique identifier of a tax group. The ID cannot be changed in edit mode.
Name [REQUIRED]	Enter the name of the tax group.
Description	Enter a text description of the tax group.

 **Note:**

Any Tax Groups created here will be "pending deployment"; however, these groups will be available for use within the other areas of the Taxes feature.

## Tax Brackets

If adding a new tax bracket:

1. At the Tax Brackets Maintenance page, click **Add** to create a new tax bracket.
2. Complete the fields as required in step 3 below.

If editing an existing tax bracket:

1. At the Tax Brackets Maintenance page, select a tax bracket from the list.
2. Edit the fields as required in step 3 below.
3. Complete the following Tax Bracket fields:

**Table 6-27 Tax Bracket Fields**

Field	Description
Bracket ID [REQUIRED]	Enter a unique identifier of a tax bracket. The ID cannot be changed in edit mode.
Tax Breakpoint [REQUIRED]	Enter the tax breakpoint, up to 6 decimal places.
Tax Amount [REQUIRED]	Enter the tax amount, up to 6 decimal places.

4. Click **Add** to add the tax breakpoint and tax amount to the Tax Bracket.

Continue adding all tax breakpoints and tax amounts for the Tax Bracket, and click **Add** after each addition to add the values to the Tax Bracket. The entered values are sorted in ascending order based on the breakpoint as they are added.

5. Click **Save** to save the Tax Bracket.

 **Note:**

Any Tax Brackets created here will be "pending deployment"; however, these brackets will be available for use within the other areas of the Taxes feature.

### Deleting a Tax Breakpoint and Tax Amount from the Tax Bracket:

- Click the Delete link associated with the tax breakpoint and tax amount.

**Figure 6-29 Delete Link - Tax Breakpoint And Tax Amount**

Bracket ID

Tax Breakpoint	Tax Amount	
<input type="text"/>	<input type="text"/>	<a href="#">Add</a>
1.00	0.050000	<a href="#">Delete</a>
1.50	0.060000	<a href="#">Delete</a>
2.00	0.070000	<a href="#">Delete</a>

### Deleting a Tax Bracket:

- In the Tax Bracket displayed, click **Delete**.

**Figure 6-30 Delete Tax Bracket**

Bracket ID 1

Tax Breakpoint	Tax Amount	
<input type="text"/>	<input type="text"/>	<a href="#">Add</a>
1.00	0.050000	<a href="#">Delete</a>
1.50	0.060000	<a href="#">Delete</a>
2.00	0.070000	<a href="#">Delete</a>

- When prompted, click **Yes** to confirm the deletion

## Tax Rates

After setting up the basic tax elements (see [Tax Elements](#)), perform the following steps to set up and manage tax rate rules and group rules.

- Select **Tax Rates** at the Taxes page ([Figure 6-27](#)), then enter/select a Tax Location and click **Next**.
- Add a new tax rate, or edit an existing tax rate for the selected tax location:

If adding a new Tax Group Rule:

- a. At the Tax Location Group Rules page, click **Add New** to create a new Tax Group Rule for the selected tax location.
- b. Complete the fields as required, then click **Save**.

If editing an existing Tax Group Rule:

- a. At the Tax Location Group Rules page, select a Tax Location Group Rule from the list.
- b. Edit the fields as required, then click **Save**. The following Tax Group Rule fields are available:

**Table 6-28 Tax Group Rule Fields**

Field	Description
Tax Group [REQUIRED]	Select the ID assigned to the tax group. The ID cannot be changed in edit mode.
Name [REQUIRED]	Enter the name assigned to the tax group.
Tax Authority [REQUIRED]	Select the Tax Authority.
Tax Type [REQUIRED]	Select the Tax Type.
Transaction Level check box	Select this check box to use this group rule at the transaction level.
Compound Tax check box	Select this check box to compound this group rule.  A compound tax is a special kind of tax that is calculated by applying it to a previously taxed item. The value of the compound tax is based on the sum of an item's price plus the tax that was previously applied to it.
Fiscal Tax ID [Country Pack ONLY]	Add the tax authority specific fiscal tax ID to the selected tax group rule.  <b>Note:</b> This field is only available for country packs. For more information on country packs, see the <i>Xstore Suite Configuration Accelerator Guide</i> .

If adding or editing a Tax Rate Rule:

- a. At the Tax Location Group Rules page, click **Edit Rates**.
  - b. Do one of the following:
    - To create a new Tax Rate Rule, click **Add New**.
    - To edit an existing Tax Rate Rule, select it in the list.
3. Complete the following Tax Rate Rules fields:

**Table 6-29 Tax Rate Rules Fields**

Field	Description
Minimum Taxable Amt	Specify the starting value amount at which the tax rate rule is first applied if the tax rate rule is applied at different thresholds.
Maximum Taxable Amt	Specify the highest value amount at which the tax rate rule is applied if the tax rate rule is applied at different thresholds.

**Table 6-29 (Cont.) Tax Rate Rules Fields**

Field	Description
Tax Rate [REQUIRED]	Select the tax rate and enter the amount, percent, or select a tax bracket.
Effective Date	Enter the date on which the tax rate rule becomes operative.
Expiration Date	Enter the date on which the tax rate rule is no longer operative.
Breakpoint	Select the breakpoint from the list.  This value determines if the tax rate rule is applied to the entire value of the transaction or only to a portion of it, if the rule has threshold values defined.

 **Note:**

The Seq. Number determines the order in which a tax is applied in a transaction. The rule with sequence number "1" is first, "2" is second, and so on.

**4. Click **Save**.**

To delete a Tax Rate Rule:

- a. Click the Delete icon associated with the Tax Rate Rule.
- b. When prompted, click **Yes** to confirm the deletion.

If adding or editing a Tax Rate Rule Override:

See If adding or editing a Tax Rate Rule. The process for Tax Rate Rule Overrides is the same as the process for Tax Rate Rules.

## Legal Entities

Use this feature to search, create and modify legal entities.

 **Note:**

This feature is mainly used for country packs. For more information on country packs, see the *Xstore Suite Country Accelerator User Guide*.

**Figure 6-31** Legal Entities Maintenance Page

If adding a new legal entity:

At the Legal Entity Maintenance page, click **Add New** to create a new legal entity.

If editing an existing legal entity:

Enter search criteria and click **Search** to find/edit a legal entity in your organization. If you do not enter any criteria before selecting **Search**, all legal entities in your organization will be returned in the search. To edit information for an existing legal entity, select the row from the search results list and click **Edit** at the legal entity information screen.

See step 6 for additional procedural information.

Complete the following Legal Entity Maintenance fields, then click **Save**.

**Table 6-30** Basic Legal Entity Attributes

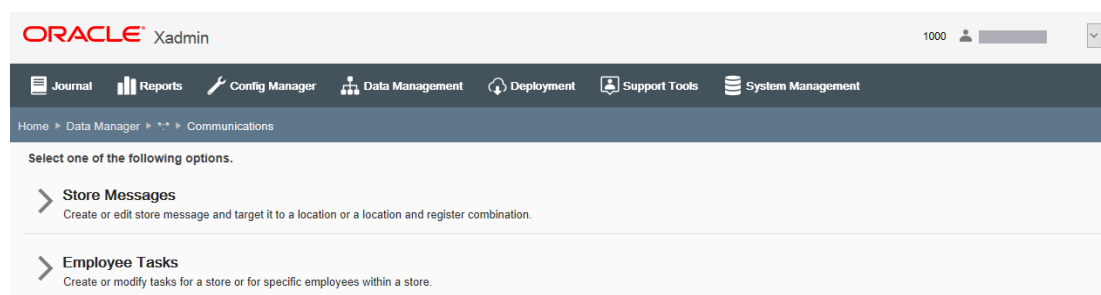
Field	Description
Legal Entity ID [REQUIRED]	Enter the ID of the Legal Entity.
Legal Entity Description [REQUIRED]	Enter a short description of the Legal Entity.
Address 1 and Address 2	Enter the address information of the Legal Entity.
City	Enter the city.
State	Enter the state.
Postal Code	Enter the postal code.
Country [REQUIRED]	Enter the country.
Tax ID	Enter the Tax ID of the Legal Entity.
Fiscal Code	Enter the Fiscal Code of the Legal Entity.
Taxation Regime	Enter the invoice issuer fiscal regime, defined by the government.
Employer ID	Enter the ID with which the company is known by the Chamber of Commerce.

**Table 6-30 (Cont.) Basic Legal Entity Attributes**

Field	Description
Activity Code	Enter the business activity code for a business in a determined country. For example, used in France where every business is classified under an activity code entitled APE (Activite Principale de l'Entreprise).
Tax Office Code and Statistical Code [Country Pack Poland ONLY]	Enter the Tax Office Code and Statistical Code for stores.

## Communications

Use this feature to create and modify store messages and employee tasks.

**Figure 6-32 Communications Options Page**

- To create or edit a store message and target it to a location, or a location and register combination, click [Store Messages](#). See [Store Messages](#) below.
- To create or modify tasks for a store or for specific employees within a store, click [Employee Tasks](#). See [Employee Tasks](#).

## Store Messages

Use this feature to create or edit a store message and target it to a location, or a location and register combination.



Figure 6-33 Store Messages Page

If adding a new message:

1. At the Store Messages page, click **Add New** to create a new message.
2. Complete the fields as required, then click **Save**.

If editing an existing message:

1. Enter search criteria and click **Search** to find/edit a store message in your organization. If you do not enter any criteria before selecting **Search**, all messages in your organization will be returned in the search.
2. To edit information for an existing message, select the row from the search results list and edit the information as needed. You also have the option here to create a new message by clicking **Add New** at the search results page.
3. Complete the fields as required, then click **Save**.

 **Note:**

To delete an existing message, click the Delete icon associated with the record at the search results list. When prompted, click **Yes** to confirm the deletion.

See step 6 for additional procedural information.

The following Store Messages fields are available:

Table 6-31 Store Messages Attributes

Field	Description
Message Scope	Identifies the scope and number of stores that will be receiving this message. The message scope is the node selected for the Data Manager session and cannot be changed here.

**Table 6-31 (Cont.) Store Messages Attributes**

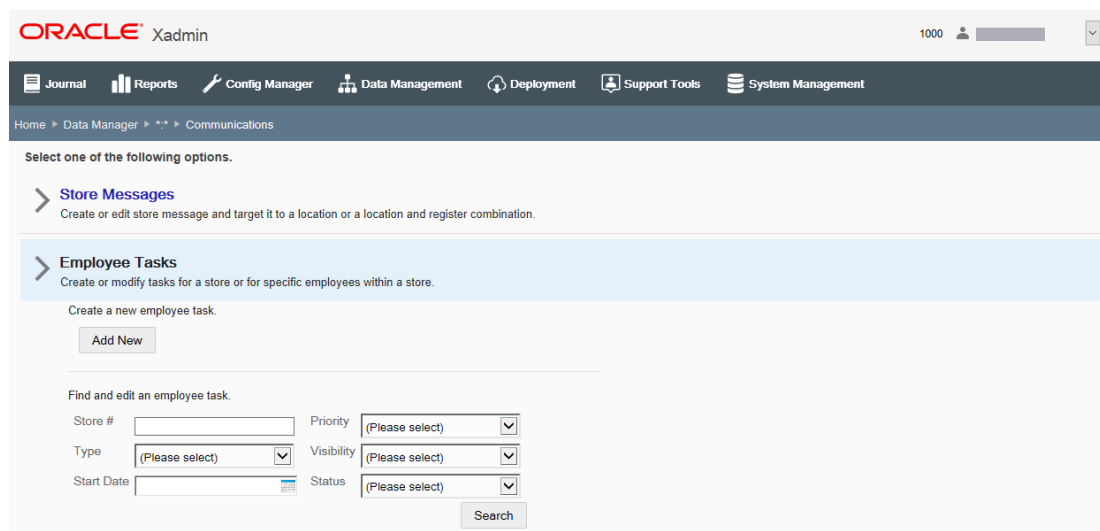
Field	Description
Register Specific check box	Select this option if the message is targeted to a specific register and enter the register number in the Register # field when prompted. <b>Note:</b> If you select this option, the message displays on only the specified workstation. If you do not select this option, the message displays on all workstations.
URL check box	Select this option if there is a URL associated with this message and enter the URL when prompted. The hyperlink will display with the message in Oracle Retail Xstore Point of Service.
Priority [REQUIRED]	Select the message priority: High, Medium, Low.
Start Date [REQUIRED]	Enter the date the message is to be displayed.
End Date [REQUIRED]	Enter the date the message is no longer displayed.
Message [REQUIRED]	Enter the message text.

## Employee Tasks

Use this feature to create or modify tasks for a store, or for specific employees within a store.

### Note:

If the store is integrated with Customer Engagement, it becomes the system of record for Employee Tasks. Therefore, Employee Tasks should be assigned from Customer Engagement, not using Xstore Office Employee Tasks functionality. If changes are completed in Xstore Office, they will be disregarded.

**Figure 6-34 Employee Tasks Page**


ORACLE Xadmin 1000

Journal Reports Config Manager Data Management Deployment Support Tools System Management

Home > Data Manager > \*\* > Communications

Select one of the following options.

> **Store Messages**  
Create or edit store message and target it to a location or a location and register combination.

> **Employee Tasks**  
Create or modify tasks for a store or for specific employees within a store.

Create a new employee task.

Add New

Find and edit an employee task.

Store #  Priority (Please select)

Type (Please select)  Visibility (Please select)

Start Date  Status (Please select)

Search

If adding a new employee task:

1. At the Employee Tasks page, click **Add New** to create a new employee task.
2. Complete the fields as required, then click **Save**.

If editing an existing employee task:

1. Enter search criteria and click **Search** to find/edit an existing employee task in your organization. If you do not enter any criteria before selecting **Search**, all employee tasks in your organization will be returned in the search.
2. To edit information for an existing employee task, select the row from the search results list and edit the information as needed. You also have the option here to create a new task by clicking **Add New** at the search results page.

 **Note:**

To delete an existing employee task, click the Delete icon associated with the record at the search results list. When prompted, click Yes to confirm the deletion.

3. Complete the fields as required, then click **Save**.

See step 6 for additional procedural information.

The following Employee Tasks fields are available:

**Table 6-32 Employee Tasks Attributes**

Field	Description
Status	This field cannot be changed. Indicates the status of the task (Open, In Process, Cancelled, and Closed).
Store # [Required]	Enter the store number. This value can only be edited in Add mode.
Task Title [Required]	Enter a short summary description of the task.
Priority [Required]	Select the task priority: High, Medium, Low.
Type [Required]	Select the type that best fits the task (General, Mailing, Display, Housekeeping, Receiving, Shipping, or Count).
Start Date [Required]	Enter the date the task should be started.
End Date [Required]	Enter the date the task should be completed.
Start Time [Required]	Enter the time the task should begin.
End Time [Required]	Enter the time the task should end.
Visibility [Required]	Select who can view this task: Store, Employee Group, or Employee.
Assignee	If the visibility selection is <b>Employee Group</b> or <b>Employee</b> , select the target assignee from the drop-down list. [REQUIRED] <b>Note:</b> The visibility field determines the drop-down list for the Assignee field. If you select Store for visibility this field will not be available.
Description [Required]	Enter a detailed description of the task.

## Exchange Rates

Use this feature to create and modify currency exchange rates for your organization.

**Figure 6-35 Exchange Rates Maintenance Page**

Base Currency	Exchange Currency	Exchange Rate	Create Date	Last Update	Last Update User	
US Dollar	Australian Dollar	1.120000	Jul 19, 2018	Jul 19, 2018	BASEDATA	×
US Dollar	Brazilian Real	3.300000	Jul 19, 2018	Jul 19, 2018	BASEDATA	×
US Dollar	British Pound Sterling	0.750000	Jul 19, 2018	Jul 19, 2018	BASEDATA	×
US Dollar	Canadian Dollar	1.450000	Jul 19, 2018	Jul 19, 2018	BASEDATA	×
US Dollar	Euro	0.850000	Jul 19, 2018	Jul 19, 2018	BASEDATA	×
US Dollar	Mexican Peso	18.800000	Jul 19, 2018	Jul 19, 2018	BASEDATA	×
US Dollar	Polish Zloty	3.670000	Jul 19, 2018	Jul 19, 2018	BASEDATA	×
US Dollar	Swedish Krona	8.560000	Jul 19, 2018	Jul 19, 2018	BASEDATA	×

If adding a new currency exchange rate record:

1. At the Exchange Rates maintenance page, click **Add New**.
2. Enter information required to create a new currency exchange rate record.
3. Click **Save**.

If editing an existing currency exchange rate record:

1. Select the record from the list to open the Edit window.
2. Make your changes, then click **Save**.

 **Note:**

To delete a currency exchange rate record, click the Delete icon associated with the record. When prompted, click **Yes** to confirm the deletion.

The following Currency Exchange Rates fields are available:

**Table 6-33 Currency Exchange Rate Attributes**

Field	Description
Base Currency	Select the local/home currency. This value can only be edited in Add mode.
Exchange Currency	Select the non-local currency used in the exchange of tenders. This value can only be edited in Add mode.

**Table 6-33 (Cont.) Currency Exchange Rate Attributes**

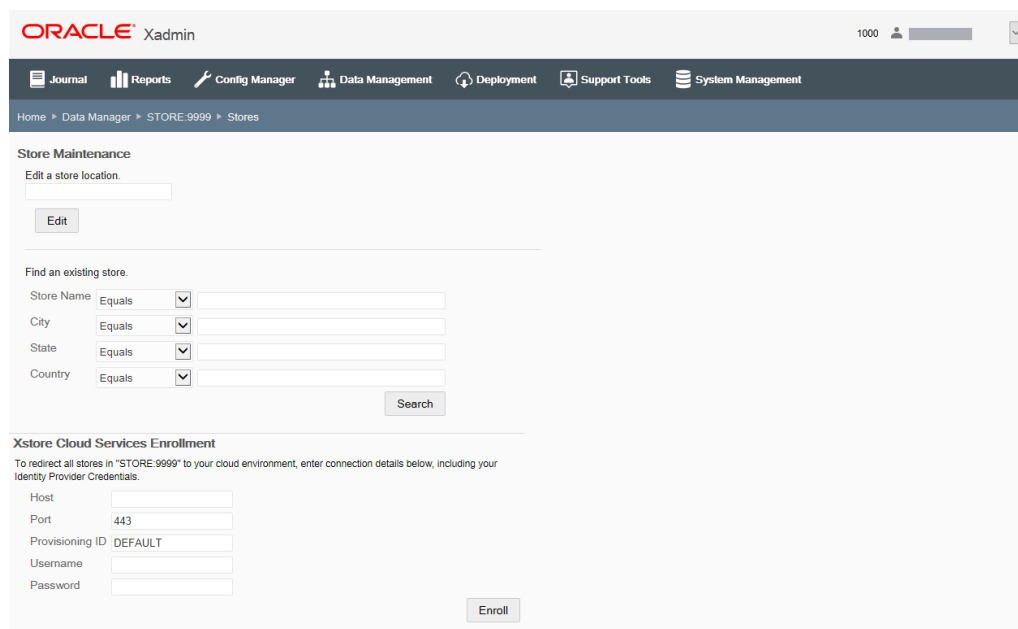
Field	Description
Exchange Rate	Enter the quantitative conversion factor between the base currency and the exchange currency.
Print As Inverted check box	Set exchange rate to Print As Inverted, to indicate that the exchange rate is printed as inverted on the receipt, so that foreign currencies whose standard exchange rate is a very small decimal number can be print on the receipt as inverted and to deal in larger numbers that are easier to understand for the customer and satisfy local conventions for showing the exchange rate.  Allows to use the 1/n value of the exchange rate in the receipts.


## Stores

### Note:

This Data Manager Stores option allows you to search for and modify store information for an existing store only. To set up a new store, see [Managing the Organization Hierarchy](#).

Use this feature to search for and modify store information.

**Figure 6-36 Stores Maintenance Page**


**ORACLE** Xadmin 1000 

Journal Reports Config Manager Data Management Deployment Support Tools System Management

Home > Data Manager > STORE-9999 > Stores

#### Store Maintenance

Edit a store location.

---

Find an existing store.

Store Name Equals

City Equals

State Equals

Country Equals

---

#### Xstore Cloud Services Enrollment

To redirect all stores in "STORE 9999" to your cloud environment, enter connection details below, including your Identity Provider Credentials.

Host

Port

Provisioning ID

Username

Password

To edit an existing store:

1. Find the store to be edited:
  - If you know the store ID, enter the store ID in the Edit a Store Location field at the Stores Maintenance page.
  - To search for a store, enter search criteria and click **Search** to find/edit an existing store in your organization. If you do not enter any criteria before selecting Search, all stores in your organization will be returned in the search. To edit information for an existing store, select the row from the search results list.
2. Click **Edit** at the Store Information screen.
3. Complete the fields as required, then click **Save**.

See step 6 on page 4 for additional procedural information. The following Stores fields are available:

**Table 6-34 Store Location Attributes**

Field	Description
Store #	The store identifier. This value cannot be changed.
Store Name [Required]	Edit the store name.
Alternate Store #	Enter the Shop ID (alternate store number) assigned to a store number as a reference to an outside/downstream integration.
Airport code	Select the airport code (IATA) assigned to a store number as a reference to calculate the TAX_FREE, TAX_NORMAL, and PRICE_SPECIAL amounts for transactions in an Airside location. Valid values are derived from data from the com_airport table in the Xcenter database.
Store Description check box	Select this option to enter a text description for the store. Type the description in the description field when prompted.
Address 1	Enter the first line of the mailing address.
Address 2	Enter the second line of the mailing address.
City	Enter the city component of the mailing address.
State	Enter the State/Province component of the mailing address.
Postal Code	Enter the Postal or ZIP code component of the mailing address.
Country	Enter/select the country component of the address.
Geographic Parameters check box	Select this option to enter the latitude and longitude values for this location.

**Table 6-35 Store Detail Attributes**

Field	Description
Tax Location	Select the identifier of the tax location.
Currency	Select the base currency used in the store.
Locale	Select the base locale for the store.
Organization Hierarchy Position	View only. This shows the store's position in the organizational hierarchy.

**Table 6-35 (Cont.) Store Detail Attributes**

Field	Description
Legal Entity	Select a legal entity associated to the country of the store. <b>Note:</b> This field is only available for country packs. Additionally,

The table below describes Store Detail fields, which are only available for country packs. The Store Detail fields may differ depending on your local fiscal requirements.


**Table 6-36 Store Detail Attributes [Country Pack ONLY]**

Field	Description
Legal Entity	Select a legal entity associated to the country of the store.
State Tax ID	Enter the Tax ID. <b>Note:</b> Only available for country pack Brazil. For more information on country packs, see the <i>Xstore Suite Configuration Accelerator Guide</i> .
City Tax ID	Enter the Tax ID of the city. <b>Note:</b> Only available for country pack Brazil. For more information on country packs, see the <i>Xstore Suite Configuration Accelerator Guide</i> .
Official Name	Enter the official name of the store. <b>Note:</b> Only available for country pack Brazil. For more information on country packs, see the <i>Xstore Suite Configuration Accelerator Guide</i> .
NFe Fiscal Regime Code	Enter the Nota Fiscal Eletrônica regime code. <b>Note:</b> Only available for country pack Brazil. For more information on country packs, see the <i>Xstore Suite Configuration Accelerator Guide</i> .
SIRET number	Enter the SIRET number. The SIRET number identifies the store and must be used in the invoices. <b>Note:</b> Only available for country pack France. For more information on country packs, see the <i>Xstore Suite Configuration Accelerator Guide</i> .

**Table 6-37 Registers/Tills Attributes**

Field	Description
Deposit Bank Name	Enter the deposit bank name to be printed when franking. The default value here is from Xadmin Settings.
Deposit Bank Account Number	Enter the deposit bank account number to be printed when franking. The default value here is from Xadmin Settings.
Number of Registers in the Store	Enter the number of registers in the store.

Table 6-37 (Cont.) Registers/Tills Attributes

Field	Description
Use Till Accountability check box	<p>IMPORTANT] If this setting is changed, you must deploy the changes at the end of the day, during the store close.</p> <p>Downloading this change during the day, while the store is open, will cause problems in Oracle Retail Xstore Point of Service.</p> <p>This setting determines whether the store uses Till Accountability mode or Register mode. Select the check box to use Till Accountability mode. The default value here is from Oracle Retail Xstore Office System Settings.</p>
Default Float Amount check box	<p>In Register Mode:</p> <ul style="list-style-type: none"> <li>If the default float amount is the same for every register/till (check box selected), enter the default float amount that applies to all registers/tills.</li> <li>If the default float amount is not the same for every register/till (check box not selected), enter an amount for the till and click <b>Add</b>. Repeat this step for all registers/tills in the store.</li> </ul> <p>A <b>Delete</b> option is available if you need to make a change.</p> <p><b>Note:</b> In Register Mode, the number of tills cannot be greater than the number of registers.</p> <p>In Till Accountability Mode:</p>  <ul style="list-style-type: none"> <li>If the default float amount is the same for every till (check box selected), enter the default float amount that applies to all tills, then enter the number of tills used in the store.</li> <li>If the default float amount is not the same for every till (check box not selected), enter an amount for the till and click <b>Add</b>. Repeat this step for all registers/tills in the store.</li> </ul> <p>A <b>Delete</b> option is available if you need to make a change.</p> <p><b>Note:</b> The store bank float amount is auto-calculated as the sum of all till float amounts.</p>
Store Manager	Enter the store manager's name.
Telephone 1 through 4	Enter the telephone numbers for the store. Telephone 1 is the primary telephone number for the store.
Store Email	Enter the store's email address.



## Viewing and Deploying the Data Changes

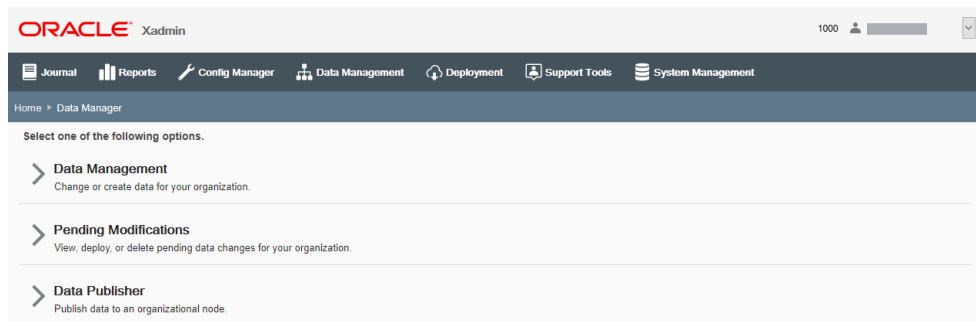
Data Manager changes are collected into "data bundles" containing all of the changes made within a particular org level during a given day. The changes collected in the data bundle will be deployed to their targeted stores automatically at the end of the day (as configured), or can be deployed immediately using the Pending Modifications option described here if needed.

 **Note:**

Any changes made after the configured time of day will collect and deploy during the next day (and the next configured time) unless the change(s) are deployed manually.

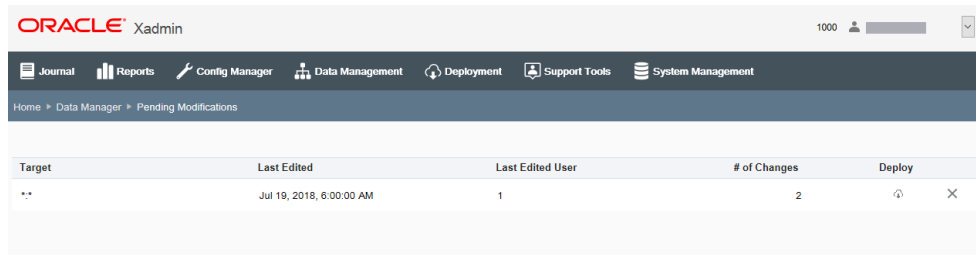
1. Click **Pending Modifications** at the Data Manager page to view and/or deploy data changes.

**Figure 6-37 Data Manager Page**



2. The Pending Modifications page shows the data bundles within the logged on user's org hierarchy level that have not been deployed. There is one row per target.

**Figure 6-38 Pending Modifications Page**



Options at the Pending Modifications page include the ability to view, deploy, or delete the changes as a whole (data bundle) including all the individual data changes that they contain.

 **Note:**

To delete only an individual data change or changes within a data bundle, see [Viewing the Individual Changes in the Data Bundle](#) in the Data Bundle.

 **Note:**

If you choose to deploy the changes here, the deployment will happen immediately. Once deployed, it is no longer possible to view or edit the data changes, (that is the group of changes will not be available to be deployed again). If an error was deployed, you must create a new data change and deploy it to fix the error.

Any deployments manually initiated from the Pending Modifications page will be shown on the Deployments page. See [Deployment Management](#) for more information.

The following information is shown on the Pending Modifications page:

**Table 6-38 Pending Modifications Page Fields**

Field	Description
Target	The org node targeted for the data bundle.
Last Edited	The date the data bundle was most recently edited.
Last Edited User	The user who last edited the data bundle.
# of Changes	The number of individual changes in this data bundle for the targeted org node.
Deploy Icon	<ul style="list-style-type: none"> <li>To deploy the Data changes as a whole (data bundle), click the Deploy icon associated with the row in the search results list.</li> <li>When prompted, click <b>Yes</b> to confirm you want to deploy the selected Data change.</li> <li>Click <b>OK</b> at the deployment scheduled successfully prompt and the row is removed from the pending modification list.</li> </ul>
Delete Icon	<ul style="list-style-type: none"> <li>To delete the Data changes as a whole (data bundle), click the Delete icon associated with the row in the search results list.</li> <li>When prompted, click <b>Yes</b> to confirm you want to delete the selected Data change and the row is removed from the pending modification list.</li> </ul>

## Viewing the Individual Changes in the Data Bundle

To view the individual changes in the data bundle, click the row in the search results list at the Pending Modifications page ([Figure 6-38](#)). The Pending Modifications Detail page lists the individual data changes that have been made within the selected group of undeployed data changes. Options here include the ability to view or delete the individual changes.

**Figure 6-39 Pending Modifications Detail Page**

Action	Area	Data Element	Last Edited	Last Edited User
Add	Tax Authority	FFTEST1, FFTest Authority Name	Jul 19, 2018, 9:12:09 AM	1
Update	Store	102, Oriole Park	Jul 19, 2018, 9:11:58 AM	1

**Note:**

To filter the list based on an Area within the group of undeployed data changes, select the Area from the drop-down list.

**Table 6-39 Pending Modifications Details Fields**

Field	Description
Action	The action that will be taken when sent to Oracle Retail Xstore Point of Service; Add, Update, or Delete.
Area	The type of data manager change.
Data Element	A description of the data manager change.
Last Edited	The date the modification was most recently edited.
Last Edited User	The user who last edited the modification.
Delete Icon	To delete the individual Data change within the data bundle, click the Delete icon associated with the row. When prompted, click Yes to confirm you want to delete the selected Data change and the row is removed from the data bundle.

## Data Publisher - Redeploying Data

This feature provides the ability to deploy data from Xcenter (a part of Oracle Retail Xstore Office) to an org node so that all data within the selected org node's scope is transferred to the selected org node.

For example, when opening a new store, use this feature to send Xcenter data to the new store.

**Note:**

The intended use of this feature is for franchise retailers that have a need to republish small amounts of data to the store. Retailers with thousands of items will likely use a merchandising system to republish items. Using this feature for a large number of items could perform slowly and could encounter out-of-memory errors.

Valid data for redeployment includes: Items, Exchange Rates, Store Messages, Taxes, Employees, and Vendors.

**Note:**

Tasks and Stores data cannot be redeployed.

Data intended for the selected node will be deployed as follows:

- A transfer to a single store may require data from a store-level, district-level, and corporate-level. In this example, all of this data will be included in the deployment.
- A transfer to a region or district may result in multiple deployments to accommodate the multiple stores within the node. For example, if transferring to a district, the district may contain a total of 10 stores, and the stores may all receive different data which will result in 10 deployments.

Depending on your security privileges, this feature also allows you to create an Omnichannel Data Service (OCDS) on demand job. On demand jobs generate `.mnt` files, containing instructions and data, necessary to refresh the Xstore and Xcenter database tables. On demand jobs are for one-time-only execution.

**Note:**

OCDS on demand jobs are only available, if the OCDS is integrated with Xstore Office,.

## Transferring Data

1. From the Oracle Retail Xstore Office menu, select **Data Management**, then **Data Manager**, or click the Data Manager link in the Data Management panel.
2. Click **Data Publisher**.
3. Select the **Target Organization Node**.

**Note:**

Only the Organization Nodes the logged-in user has privileges to use will be listed here.

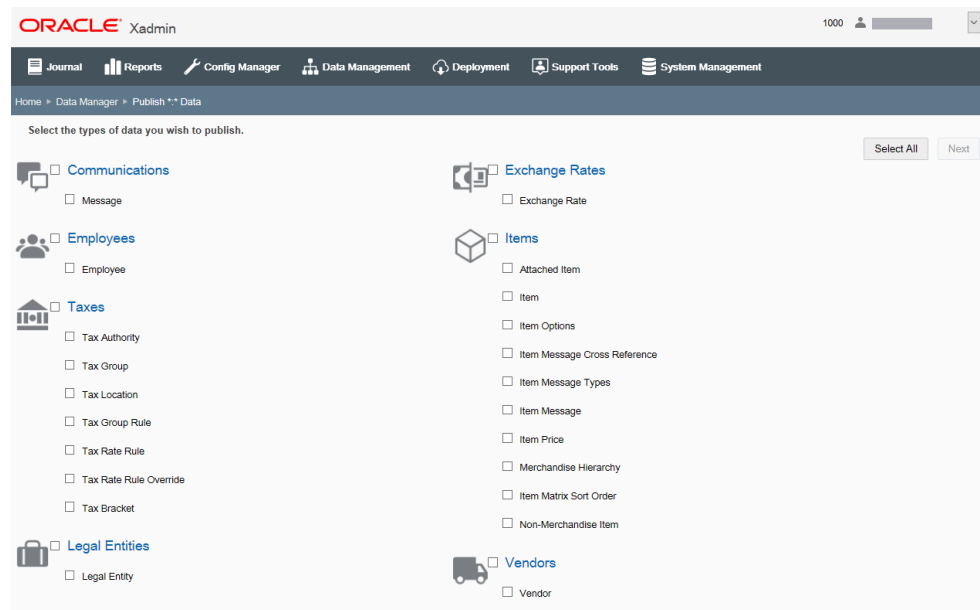
4. Select the **Data Source** option. Available options are Xstore Office or OCDS (Omni Channel Data Service).

 **Note:**

The **Data Source** option is only available, if you hold the necessary security privileges and if Omni Channel Data Service is integrated with Xstore Office..

5. Then click **Next**.
6. At the Publish Data page, select the types of data to be transferred from Xcenter (a part of Oracle Retail Xstore Office) to the targeted org node:

**Figure 6-40 Publish Data Page**



- To transfer all data listed here to the targeted org node, click the **Select All** button.

 **Note:**

When all categories are selected, the button toggles to "Select None". If selected, all check marks will be removed.

- To transfer all data in a category, select the check box next to the category name.
  - To transfer specific data within a category, select the check box next to the data item.
7. Click **Next**.
  8. At the Target Node Information window, review your changes and select a download priority option - Immediate or Store Close - from the drop-down list.

**Figure 6-41 Target Node Information Window**



9. Click **Deploy**.
10. When prompted that the deployment was scheduled successfully, click **OK** to close the window.

 **Note:**

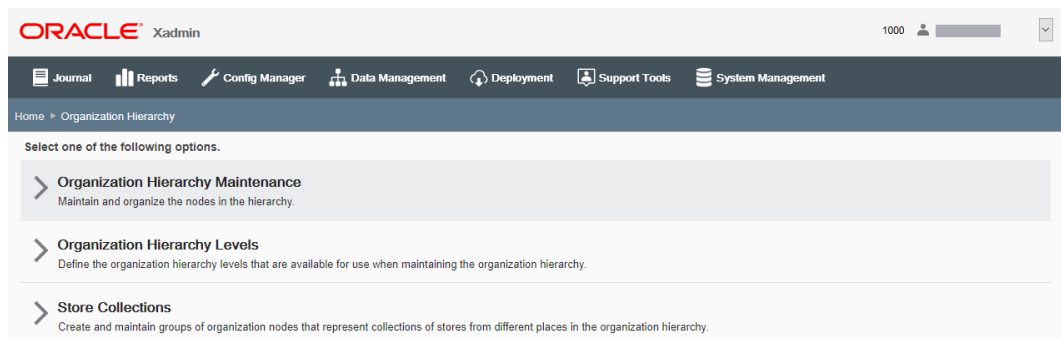
about Deployment If the deployment of data should fail for one (or more) nodes within the target, the entire deployment will not fail. In this case, the progress bar turns red, indicating an error. At the end of the transfer, a failure count is shown above the progress bar (that is 5/250), and you can click a provided link to see more information at the "View Deployments" page.

## Managing the Organization Hierarchy

Organization Hierarchy management includes both defining the hierarchy levels in your organization, as well as organizing and maintaining the nodes in the hierarchy.

1. From the Oracle Retail Xstore Office menu, select **Data Management**, then **Organization Hierarchy**, or click the Organization Hierarchy link in the Data Management panel.
2. At the Organization Hierarchy page, you have the following options:.

**Figure 6-42 Organization Hierarchy Page**



- To define organization hierarchy levels, click Organization Hierarchy Levels. Refer to [Defining Organization Hierarchy Levels](#) below for procedural information.
- To maintain and organize the nodes in the hierarchy, click Organization Hierarchy Maintenance. Refer to [Managing the Organization Hierarchy](#) for procedural information.
- To create and maintain store collections, click Store Collections. Refer to [Creating and Maintaining Store Collections](#).

## Defining Organization Hierarchy Levels

Use this feature to define the Organization Hierarchy levels in your organization. Once set up, these levels will be available for use in Organization Hierarchy Maintenance.

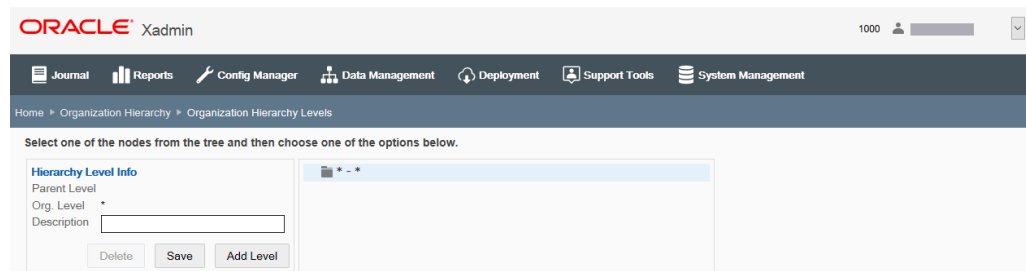
The Parent (root) Level field cannot be edited, and only one root level (\*) is allowed.



### Note:

STORE is a reserved word within organization hierarchy maintenance and cannot be added as an organization level.

**Figure 6-43 Organization Hierarchy Levels Page**



## Adding an Organization Hierarchy Level

1. Select an org node within the org hierarchy tree.
2. With the node selected, click **Add Level** to add an org level to the selected node.
3. Complete the fields as required and click **Save**.

**Table 6-40 Organization Hierarchy Levels Fields**

Field	Description
Parent Level	Defaults to the currently selected node and cannot be changed.
Org Level [Required]	Enter the name of the new org level.
Description	Enter a description for the new org level.

## Editing the Description of an Organization Hierarchy Level

1. Select an org node within the org hierarchy tree.
2. With the node selected, enter the description in the Description field.
3. Click **Save**. The tree view description is updated with the new description.

## Deleting an Organization Hierarchy Level

1. Select an org node within the org hierarchy tree.
2. With the node selected, click **Delete**.

 **Note:**

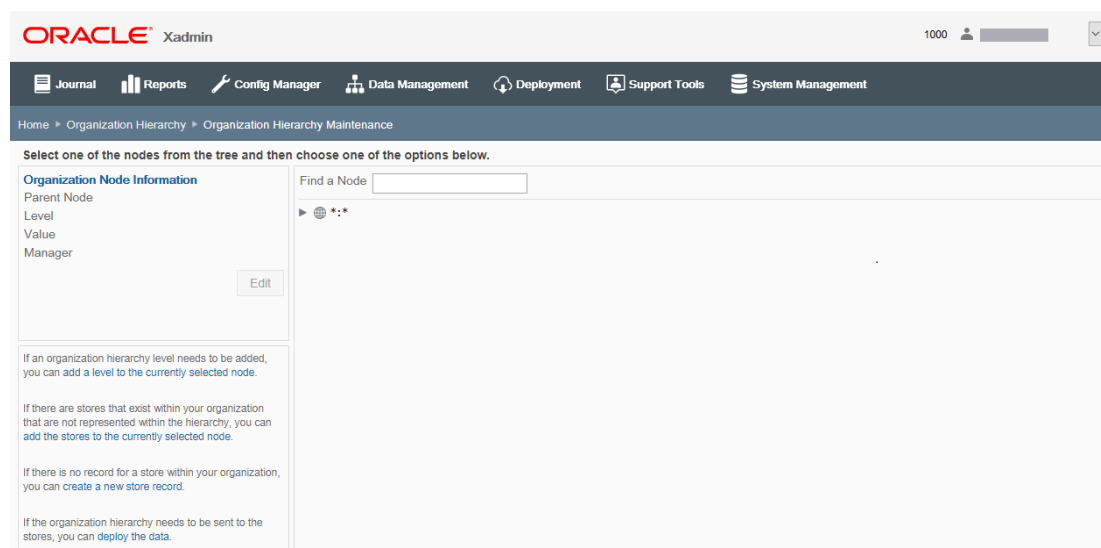
Levels that are currently being used, that is, levels with children, cannot be deleted.

3. When prompted, click **Yes** to confirm you want to delete the selected hierarchy level.

## Maintaining the Organization Hierarchy

The Organization Hierarchy Maintenance feature provides the ability to add an organization hierarchy level to a node, create a new store and add it to an org node, add an existing, unassigned store to an org node, temporarily deactivate an org node, and deploy the changes.

**Figure 6-44** Organization Hierarchy Maintenance Page







**Note:**

To search for a specific node, begin typing the node description in the Find a Node field.

## Adding an Organization Hierarchy Level to a Node



**Note:**

Organization Hierarchy levels must be defined before they can be used in Organization Hierarchy Maintenance. See [Defining Organization Hierarchy Levels](#) for more information about setting up Organization Hierarchy levels for your organization.

Perform the following steps to add an organization hierarchy level to a node.

1. From the Organization Hierarchy Maintenance page, select an org node within the org hierarchy tree.
2. With the node selected, click the add a level to the currently selected node link.
3. In the Add Hierarchy Level Node window, complete the fields as required:

**Table 6-41 Add Hierarchy Level Node Window**

Field	Description
Parent Node	Defaults to the currently selected node.
Level [Required]	Select the new level from the drop-down list. Organization Hierarchy levels must be defined before they can be used in Organization Hierarchy Maintenance. See <a href="#">Defining Organization Hierarchy Levels</a> for more information about setting up Organization Hierarchy levels for your organization.
Value [Required]	Enter a value for the new level.
Manager	Enter the manager for the new level. This is a level manager or an org node manager (for example, district manager). The value is stored in the org hierarchy table along with the node info.
Active Node check box	Selected by default, indicating the organization hierarchy level is active and available. To deactivate the org node, deselect the <b>Is this node active?</b> check box. Refer to <a href="#">Deactivating an Org Node</a> for more information.

4. Click **Save**.

## Editing the Value and Manager Information

Perform the following steps to edit an organization hierarchy level value and/or manager.

1. Select an org node within the org hierarchy tree.
2. With the node selected, click **Edit**.
3. Make changes to the level Value and/or Manager as needed.
4. Click **Save**.

 **Note:**

To deactivate the org node, deselect the Is this node active? check box. Refer to [Deactivating an Org Node](#) for more information.

## Adding Unassigned Stores to an Org Node

Perform the following steps to add any unassigned stores to the organization hierarchy. This process does not create new stores, it is used to add existing stores to the Organization Hierarchy tree.

1. Select an org node within the org hierarchy tree.
2. With the node selected, click the **Add** the stores to the currently selected node link to display a list of all unassigned stores.
3. Select the check box for one (or more) stores from the list, then click **Add** to add the selected stores to the selected org node.
4. The stores are added to the selected org node and the system returns to the Organization Hierarchy Maintenance page.

## Creating a New Store and Add It to an Org Node

Perform the following steps to create a new store and place it within the organization hierarchy. This process is not used to add existing stores to an org hierarchy node.

1. Select the node where the new store will be placed.
2. With the node selected, click the Create a new store record link.
3. Complete the required fields in the Store wizard, then click **Save**.  
This is the same wizard used to edit stores within Data Manager; see [Stores](#) for detailed information about the fields.
4. When prompted, click **OK** to close the "Store created successfully" prompt. A deployment of this record to all stores will now be scheduled.
5. When prompted, click **OK** to close the "Deployment was scheduled successfully" prompt.
6. The system returns to the Organization Hierarchy Maintenance page. The new store is added to the selected org node.

## Deactivating an Org Node

Perform the following steps to deactivate an org node. Deactivated org nodes will not appear in drop-down pick lists throughout Oracle Retail Xstore Office. Making an org node inactive does not stop the stores within that node from functioning. This inactive setting simply prevents users from making data changes and deployments to the node. For example, this feature may be used when creating new districts or reorganizing the hierarchy. Deactivating

an org node ensures that other users cannot make data changes or deployments to the stores that fall within that node.

Perform the following steps to deactivate an org node.

1. Select an org node within the org hierarchy tree.
2. With the node selected, click **Edit**.
3. Deselect the Is this node active? check box.
4. Click **Save**.
5. The org node information shows the node is Inactive and the org node is grayed-out in the tree view.

**Figure 6-45 Inactive Org Node Example**

The screenshot displays the Oracle Organization Hierarchy Maintenance interface. At the top, there is a navigation bar with icons for Journal, Reports, Config Manager, Data Management, and Deployment. Below this is a breadcrumb trail: Home > Organization Hierarchy > Organization Hierarchy Maintenance. A message reads: "Select one of the nodes from the tree and then choose one of the options below." The interface is split into two main sections. On the left, the "Organization Node Information" panel shows details for a selected node: Parent Node: GROCERY:AT, Level: STORE, Value: 9902, Manager: Store 9902 Manager, and a status of "Inactive" which is highlighted with a red box. An "Edit" button is visible. On the right, a "Find a Node" search box is present above a tree view. The tree view shows a hierarchy: CORP:\* (expanded), REGION:1, REGION:2, REGION:3, REGION:4 (expanded), GROCERY:AT (expanded), STORE:9901, STORE:9902 (highlighted with a red arrow), and FRANCHISE:\*. Below the information panel, a note states: "If an organization hierarchy level needs to be added, you can add a level to the currently selected node."

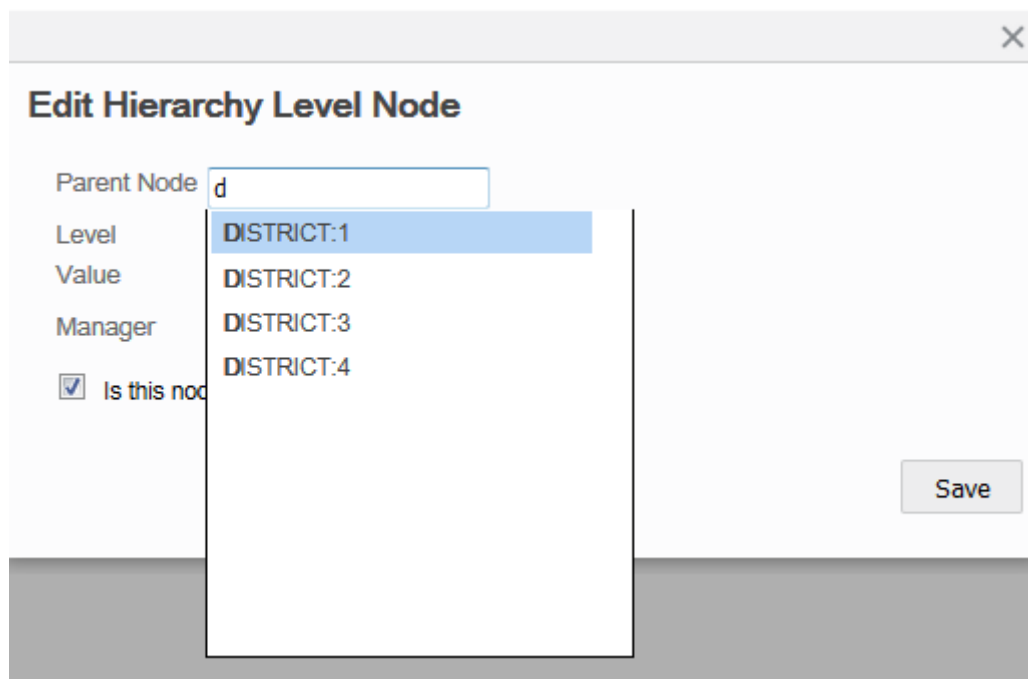
 **Note:**

To activate an inactive org node, select the Is this node active? check box.

## Moving an Org Node

Perform the following steps to move org nodes throughout the org hierarchy. For example, this feature can be used if redistributing actions are needed within the organization. This type of movement may be as simple as: Move STORE:101 from DISTRICT:2 to DISTRICT:3, or it may be more complicated and involve multiple moves. In either case, the process is the same.

1. Select an org node (other than the root node) within the org hierarchy tree.
2. With the node selected, click **Edit**.
3. To change the selected node's parent level, begin typing the node identifier in the Parent Node field. The suggested parent nodes are displayed in a list.

**Figure 6-46** Parent Node Suggestion List

4. Select the new parent level, then click **Save**.  
The previously selected node is now shown under its new parent level.

## Deploying the Organization Hierarchy Changes

Perform the following steps to deploy the organization hierarchy data to the stores.

1. Click the deploy the data link.
2. When prompted, click **Yes** to deploy the organization hierarchy to all stores.
3. Click **OK** to close the deployment successful window.

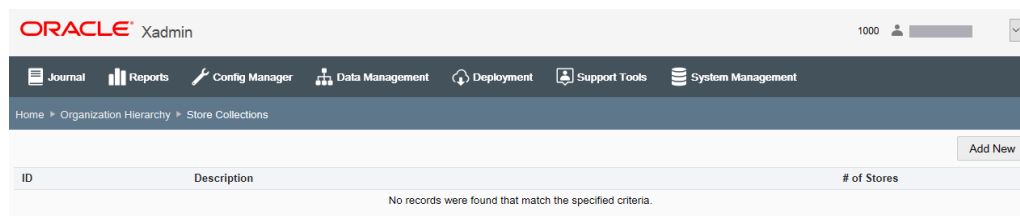
## Creating and Maintaining Store Collections

Use Store Collections to create and maintain groups of organization nodes that represent collections of stores from different places in the organization hierarchy.

Store Collections are user-defined store groups. Once defined and set up, these Store Collections are made available to be used as target areas for configuration and data changes.

The Store Collections page shows your current Store Collections and the number of stores in each collection. In the example below, two store collections have been defined. If no collections have been defined this page will be blank. Click a column header to sort the column as needed.

Figure 6-47 Store Collections Page



## Adding a Store Collection

1. At the Store Collections page, click **Add New** to create a new store collection.
2. Complete the fields as required:
  - ID - Enter the collection identifier. This field can only be edited when adding a new Store Collection. A store collection ID must be letters or numbers only and cannot include a colon (:), underscore (\_), or comma (,) in the name.
  - Description - Enter the collection description. This field can be changed when adding a new Store Collection, and when editing an existing Store Collection.
  - Organization Nodes - Specify the node belonging to this store collection, then click Add. Repeat this step for each node that is part of this collection.
3. Click **Save**.
4. Oracle Retail Xstore Office returns to the Store Collections page.

## Editing a Store Collection

1. At the Store Collections page, select a Store Collection from the list.

### Note:

To delete a store collection, at the Store Collections page, select the Delete icon associated with the Store collection. When prompted, click **Yes** to confirm the deletion

2. Complete the fields as required:
  - ID - This field cannot be changed.
  - Description - Edit the collection description.
  - Organization Nodes
    - To add a node, specify the node belonging to this store collection, then click **Add**. Repeat this step for each node to be added to this collection.
    - To remove a node from the collection, click the Delete link associated with the node.
3. Click **Save**.
4. Oracle Retail Xstore Office returns to the Store Collections page.

# Stock Valuation Year End Roll-Up

The end-of-year process is used to post the required rollup data for stock valuation for all items and stores. This closes the item's quantity and value for the specified fiscal year. The consolidated inventory totals are used for the stock valuation (PWAC) reports.

## Note:

The `inv_cst_item_yearend` table must be populated with data for the previous year. For new retailers with no previous years' data, a record must be added for the previous year with quantity zero (0).

## Overview

Stock Valuation is a process that allows you to track the item stock value for receivables at the store for both corporate-created receiving documents and store-created receiving documents. This inventory valuation allows you to determine a monetary value for items that make up your inventory, and is dependent on a year-end process for the company. Stock valuation is based on the fiscal calendar.

All receiving documents must contain the items' cost to be used to calculate the stock valuation. The cost is the amount charged to the franchisee/store. When merchandise is received from the warehouse, the cost on the ASN/receiving document must be accepted or adjusted by the store in order to receive merchandise into inventory.

## End-Of-Year Processing

To access Stock Valuation Year End Roll-up, select **Roll-up Stock Valuation** from the Data Management menu.

Perform the following steps to post the required rollup data for stock valuation for all items and stores.

1. Enter the Fiscal year that is being closed.
2. Click **Roll-up Data**.

The system will perform the following validation checks on the Fiscal Year entered:

- Must be less than the current fiscal year.
- Cannot be greater than the last consolidated year + 1. (The sequence must be respected; if 2011 has been consolidated, you can only consolidate 2012.)
- Cannot be less than the last consolidated year. (If 2012 has been consolidated you cannot select 2010, but you can select 2012.)
- If there are no previous consolidations, the system can accept any value less than the current year. (In this case, if there are any documents in the database for the year before the selected year, all documents will be consolidated in the selected year.)

Example:

Current year=2014

Documents exist in the database for 2009, 2010, 2011, 2012, and 2013

No consolidations have been done to date

If 2012 is selected as the closing year, the system will prompt to close previous years (2009, 2010, 2011) first before continuing.

# 7

## Deployment Management

Deployment Manager is used to upload files for deployment, create deployment plans for scheduling updates, and track the status of configuration and file deployments. For additional technical information about Deployments, see [Appendix: About Deployments](#) .

### The Deployment Process at a Glance

1. Oracle Retail Xenvironment contacts Xcenter (a part of Oracle Retail Xstore Office) at a pre-defined interval, asking for any updates.
2. If updates are available, Oracle Retail Xstore Office downloads the files specified by the manifest either immediately or at the daily maintenance.
3. Oracle Retail Xenvironment then applies the files per the instructions in the manifest either immediately or at the daily maintenance.

### About this Chapter

The File Upload feature provides the ability to upload files from your local PC into Oracle Retail Xstore Office so the files can be deployed to stores. A deployment is automatically scheduled based on the targeting information in the file header. Oracle Retail Xstore Point-of-Service software updates, standard DataLoader files (.dat, .mnt,

.reo, .rep), Oracle Retail Xstore Point-of-Service .cip files, .zip files for JRE/JCE, .tar.gz files, and Oracle Retail Xstore Point-of-Service debit.txt files are supported for upload. See [Uploading Files](#) below.

The View Deployments feature provides both the ability to view detailed information about a deployment and the ability to cancel a deployment before it has been deployed if it meets the eligibility criteria. The current status of all deployments made from Oracle Retail Xstore Office can be tracked down to the store level. You can view summary level data for each deployment, down to the status of delivering and loading each update at each target store. See [Viewing Deployments](#).

The Deployment Plans feature provides the ability to define phased Deployment Plans (such as templates) that can be used to schedule Configurator updates or File Uploads to save time when scheduling roll-outs. See [Deployment: Using a Deployment Plan](#).

The Automatic External File Delivery feature provides the ability to have any standard DataLoader files (.dat, .mnt, .reo, .rep) left by any external system in a file drop directory so the files can be deployed to stores. See [Automatic External File Delivery](#).



# Uploading Files

## Note:

Only the uploaded files that fall within the current user's org node are shown on the File Upload page. Files must have been uploaded by a user with the same, or lower, org node as the current user.

## Note:

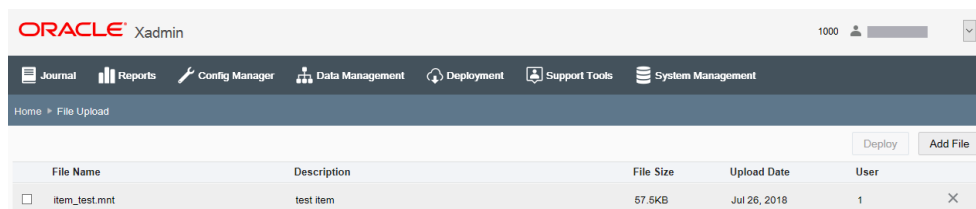
In Oracle Retail Xstore Office certain privileges are available which control the users who have the ability to access the file upload feature and who can upload files which are to be deployed.

Additionally, it is possible to control the ability to deploy one or more of the uploaded files.

The 'File Deploy' privilege should not be assigned to a user who has either the 'File Upload' or the 'Upload File to Deploy' privilege. One user should be restricted to have only the right to upload files for deployment, while another user is required to deploy the uploaded files. As a result critical deployments need to be independently approved, before they are made available to other systems.

1. From the Oracle Retail Xstore Office menu, select **Deployment - File Upload**, or click the File Upload link in the Deployment Manager panel.
2. At the File Upload page, click **Add File** to browse for the file you want to upload.

**Figure 7-1 File Upload Page**



File Name	Description	File Size	Upload Date	User	
<input type="checkbox"/> item_test.mnt	test item	57.5KB	Jul 26, 2018	1	X

## Note:

Only files with the following valid extensions can be uploaded: .cip, .jar, .mnt, .rep, .reo, .dat, debit.txt (bin file), .tar.gz, and .zip. All uploaded files are compressed when a deployment is scheduled and are decompresses once they are deployed.

- When prompted, click **Browse** to search for the file.

**Figure 7-2 Select File to Upload Window**

- [OPTIONAL] Type a description for the file.
- Click **Upload**. Uploaded file records are stored in the `cfg_upload_record` table.

 **Note:**

If you try to upload a file that has been previously uploaded, you are prompted that this new upload will overwrite the previous one. Click **Overwrite** to overwrite the previous file or **Cancel** to return to the File Upload page without uploading the file.

- At the Upload Successful progress bar, choose whether to deploy the file now or deploy the file later:

**Figure 7-3 Upload Successful Progress Bar**

- Click **Yes** to deploy the file now. Skip to File Upload: Deploying a File or Files, step 3.

- Click **No** to return to the File Upload page without deploying the file.
7. Perform actions as needed:
    - To upload additional files, repeat steps 2 through 6.
    - To deploy an uploaded file, see [File Upload: Deploying a File or Files](#).
    - To remove a file from the Upload File list, see [File Upload: Removing an Uploaded File From the List](#).

## File Upload: Removing an Uploaded File From the List

Follow the instructions in this section if you need to remove an uploaded file from the list.

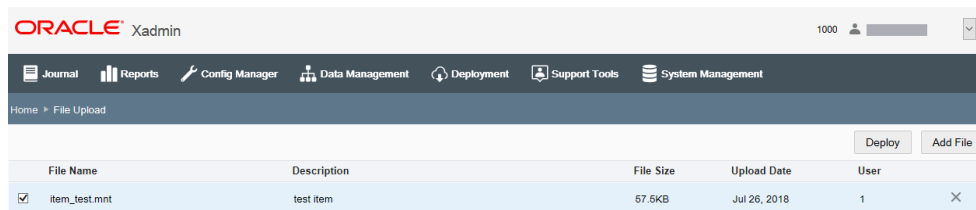
1. At the File Upload page, click the Delete icon to remove the selected file from the list.
2. At the confirmation prompt, click **Yes** to remove the selected file.

## File Upload: Deploying a File or Files

Follow the instructions in this section to deploy a file or multiple files.

1. At the File Upload page, select the file, or files, you want to deploy.

**Figure 7-4 File Upload Page - File Selected**

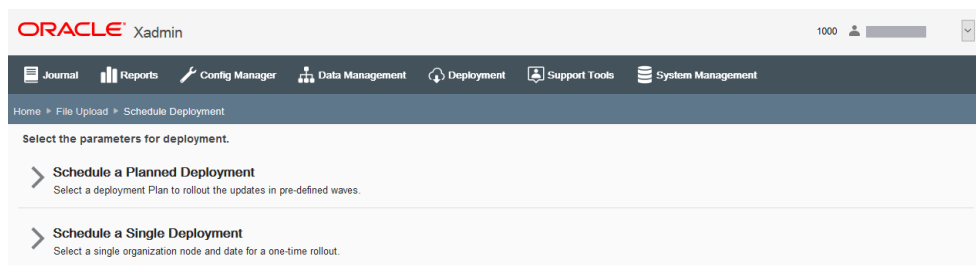


The screenshot shows the Oracle Xadmin interface. The breadcrumb trail is 'Home > File Upload'. There are 'Deploy' and 'Add File' buttons. A table lists the uploaded files:

File Name	Description	File Size	Upload Date	User
<input checked="" type="checkbox"/> item_test.mnt	test item	57.5KB	Jul 26, 2018	1

2. Click **Deploy**.
3. At the Schedule Deployment page, select a deployment option:

**Figure 7-5 Schedule Deployment Page**



- **Schedule a Planned Deployment** -Select this option to use a pre-defined Deployment Plan to roll out the updates in waves. Skip to [Deployment: Using a Deployment Plan](#).

 **Note:**

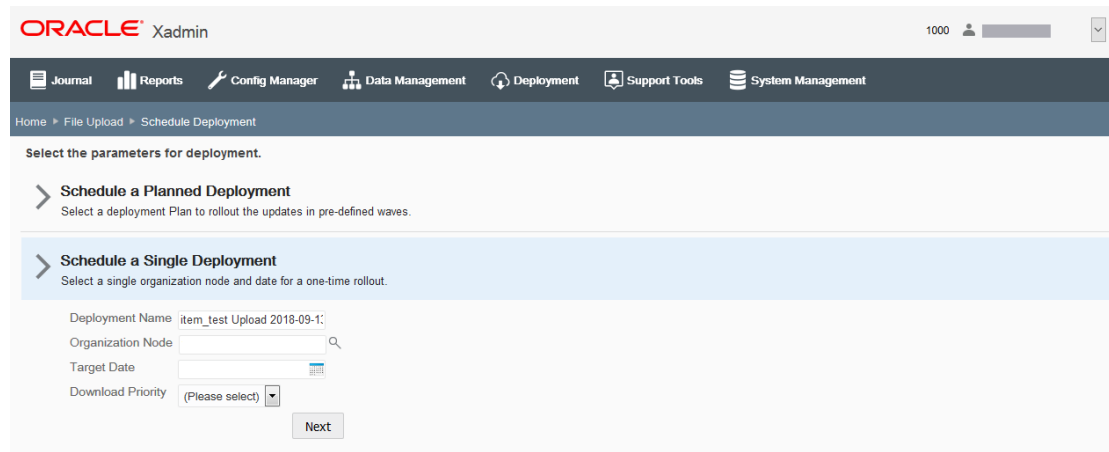
This option assumes at least one Deployment Plan has been defined. See [Creating a Deployment Plan](#) for more information about setting up a Deployment Plan.

- Schedule a Single Deployment - Select this option for a one-time rollout to a single organization node and date. Continue with Deployment: Using a Single Deployment.

## Deployment: Using a Single Deployment

If you selected Schedule a Single Deployment in step 3 on page 4, the Single Deployment section of the screen expands to show the required fields.

**Figure 7-6 Single Deployment Fields**



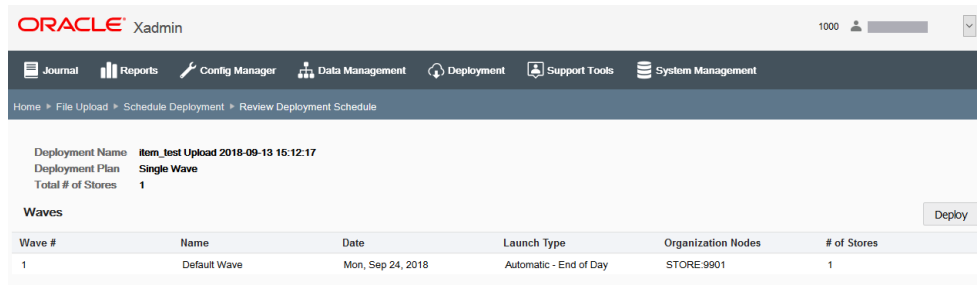
1. Complete the following fields, then click **Next**. All fields are required.


**Table 7-1 Single Deployment Fields**

Field	Description
Deployment Name	This field defaults to the file name and date it was uploaded. Accept this default or enter a name to identify this deployment.
Organization Node	Select the organization target for the configuration changes.
Target Date	Select the date the changes will be sent to the store.
Download Priority	Select the download priority to be specified in the manifest: Immediate - Download the files now. End of Day - Download the files at end-of-day.

2. Review the deployment information:

**Figure 7-7 Single Wave: Review Deployment Schedule**



 **Note:**  
Waves Section - For Single Deployments, the Wave Name defaults to Default Wave and the Launch Type defaults to Automatic. These values cannot be changed.

The following Wave information is shown on the Review Deployment Schedule page:

**Table 7-2 Review Deployment Schedule Fields**

Field	Description
Wave #	The wave identifier.
Name	For Single Deployments, the Wave Name defaults to Default Wave and cannot be changed.
Date	The date the changes will be sent to the store.
Launch Type	The launch type, defaults to Automatic.
Organization Nodes	The targeted org node or nodes.
# of Stores	The number of stores affected by this single deployment.

- If all information is correct, go to step 6 below.
  - If you need to change the launch date, select the wave and enter the new date at the Edit Wave window, then click **OK**.
  - If you need to make any other changes, click the Schedule Deployment breadcrumb to return to the previous page where you can edit the information. Go to step 4 on page 5.
3. Click **Deploy**.
  4. When prompted, click **Yes** to confirm you want to schedule the deployment.
  5. Click **OK** to close the Deployment Scheduler status bar window.

The deployment file is placed in the root directory of Apache Server with a file name of

`{org}_{deployment id}_!_{filename}` and a record is written to the `dpl_deployment` table.

See [Viewing Deployments](#) for more information about the deployed file.

## Deployment: Using a Deployment Plan

Templates, known as Deployment Plans, can be set up in advance and then reused whenever needed. These Deployment Plans are used to distribute changes to stores for configuration and file uploads. See [Creating a Deployment Plan](#).

If you selected Schedule a Planned Deployment in File Upload: Deploying a File or Files, the Deployment Plan section of the screen expands to show the required fields.

**Figure 7-8 Planned Deployment Fields**

The screenshot shows the Oracle Xadmin interface for scheduling a deployment. The breadcrumb trail is Home > File Upload > Schedule Deployment. The main heading is 'Schedule a Planned Deployment' with the instruction 'Select a deployment Plan to rollout the updates in pre-defined waves.' The form contains three input fields: 'Deployment Name' with the value 'item\_test Upload 2018-09-13 15:11:57', 'Deployment Plan' with a dropdown menu showing '(Please select)', and 'Target Date' with a date picker icon. A 'Next' button is located to the right of the 'Target Date' field. Below this section is another option, 'Schedule a Single Deployment', with the instruction 'Select a single organization node and date for a one-time rollout.'

1. Complete the following fields.

**Table 7-3 Planned Deployment Fields**

Field	Description
Deployment Name	This field defaults to the file name and date it was uploaded. Accept this default or enter a name to identify this deployment.
Deployment Plan	Select the deployment plan from the list.
Target Date	Select the date the changes will be sent to the store.

2. Click **Next**.

**Note:**

All deployments using a Plan will start at the Daily Maintenance.

3. Review the deployment schedule and Email Notification list, then click **Deploy**.

Figure 7-9 Review Deployment Schedule Page

ORACLE Xadmin 1000

Journal Reports Config Manager Data Management Deployment Support Tools System Management

Home > File Upload > Schedule Deployment > Review Deployment Schedule

Deployment Name: **Item\_test Upload 2018-09-14 12:41:22** Email Notifications: [View List](#)

Deployment Plan: **Plan 300**

Total # of Stores: **1**

Waves Deploy

Wave #	Name	Date	Launch Type	Organization Nodes	# of Stores
1	Wave 1	Mon, Sep 24, 2018	Approval Required	STORE:9901	1

**Note:**

If you are not ready to deploy, use the breadcrumbs at the top of the page to navigate to a previous page.

4. When prompted, click **Yes** to confirm you want to schedule the deployment.
5. Click **OK** to close the Deployment Scheduler status bar window.

See also [Viewing Deployments](#) for more information about tracking the current status of all deployments.

## Creating a Deployment Plan

Use a Deployment Plan to roll out updates on a pre-defined schedule when setting up a Configurator or File Upload deployment. Scheduled roll-outs are created by defining phased plans (that is templates) containing Waves. The plans created here will be available when you schedule a deployment. See [Deployment: Using a Deployment Plan](#).

1. From the Oracle Retail Xstore Office menu, select **Deployment - Deployment Plans**, or click the Deployment Plans link in the Deployment Manager panel.
2. At the Deployment Plans page, click **Add New** to create a new Deployment Plan.

Figure 7-10 Deployment Plans Page

ORACLE Xadmin 1000

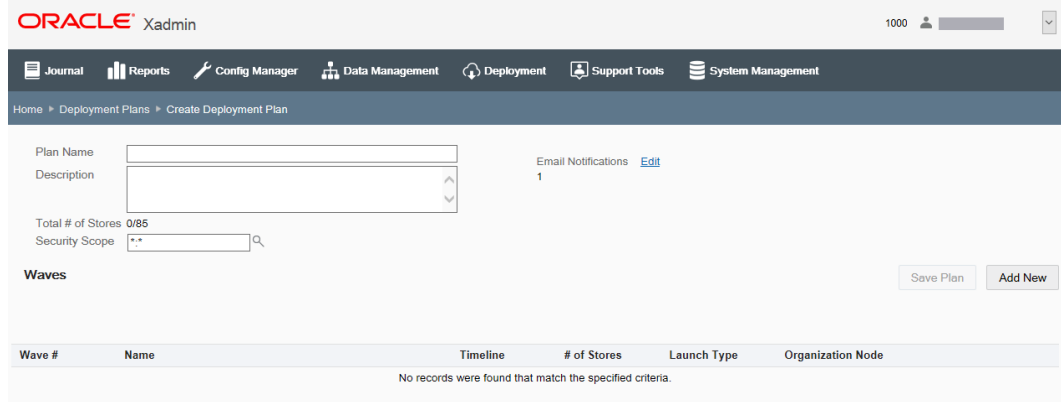
Journal Reports Config Manager Data Management Deployment Support Tools System Management

Home > Deployment Plans Add New

Plan ID	Plan Name	Security Scope	# of Waves	Created On	Description
No records were found that match the specified criteria.					

3. At the Create Deployment Plan page, complete the fields as required to identify this plan and to define the scope:

**Figure 7-11 Creating Deployment Plan Page**

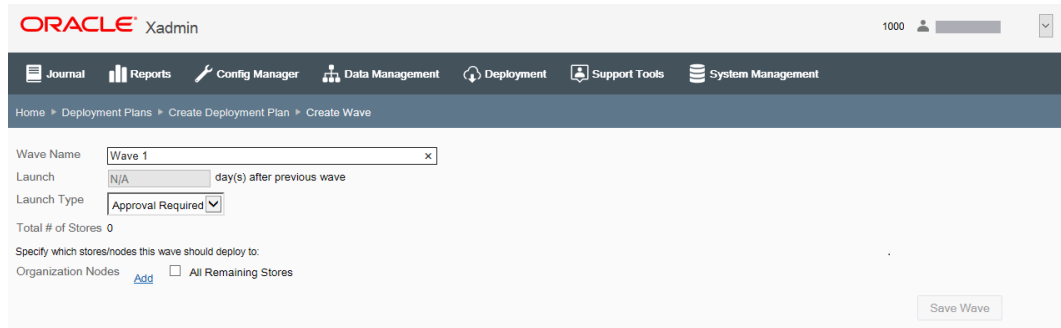


**Table 7-4 Creating a Deployment Pan Fields**

Field	Description
Plan Name	Enter a name for the plan, up to 60 characters.
Description	Enter a description for the plan, up to 255 characters. This name can be changed after the plan has been created and saved.
Security Scope	Select the target level (store or org node) for this plan. This value defaults to the highest level of the logged-on user. If a user has more than one hierarchy node assigned, there is no default.
Email Notifications	Review/edit the email addresses for emails to be sent for Wave Approval reminders and Wave Approval waiting notifications. See <a href="#">Email Notifications</a> for more information about this feature.

4. Click **Add New** to define the Waves for this plan at the Create Wave page:

**Figure 7-12 Create Wave Page**





 **Note:**

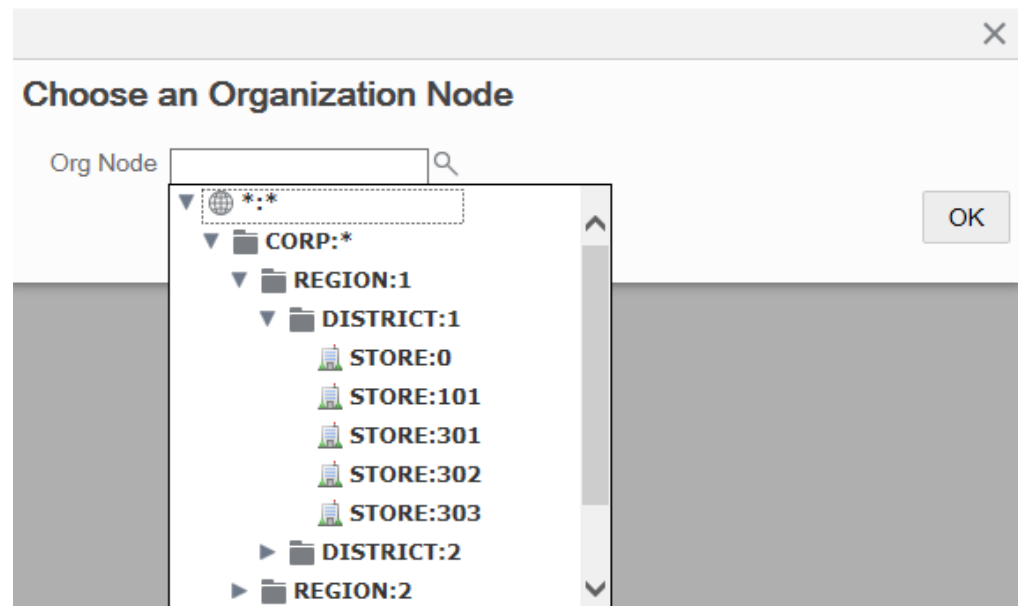
To be valid, a Deployment Plan must have a minimum of one Wave. You can add any number of Waves to the Deployment Plan. For global scope only, you can select the All Remaining Stores check box to quickly add all stores in the node that have not been included in any previous waves. This can be used to make sure there are no missing stores in the Deployment Plan.

**Table 7-5 Create Waves Fields**

Field	Description
Wave Name	Enter the Wave name or accept the default name. By default, each Wave is numbered automatically to track the number of waves in the plan. You can append additional text to the wave number (for example, Wave 1: Reg1) or change the text (for example, First Wave - Reg1), up to 60 characters.
Launch (day(s) after previous wave)	For Wave 1, this will default to NA since the first wave is the baseline date used to calculate all subsequent days. For Waves 2 and above, enter the interval between waves, up to 4 digits maximum. <b>Note:</b> Zero (0) is a valid entry for the number of days after the previous wave. This allows multiple waves to start on the same day, possibly with different launch types.
Launch Type	Approval Required [DEFAULT] - User approval is needed before the Wave launches. Automatic - The Wave launches automatically on the set number of days after the previous wave completes.

5. To specify which stores/nodes this Wave should deploy to:
  - a. Click **Add Organization Nodes**.
  - b. Expand the org hierarchy node tree as needed to select the stores/nodes for this Wave.

**Figure 7-13** Org Hierarchy Node Tree



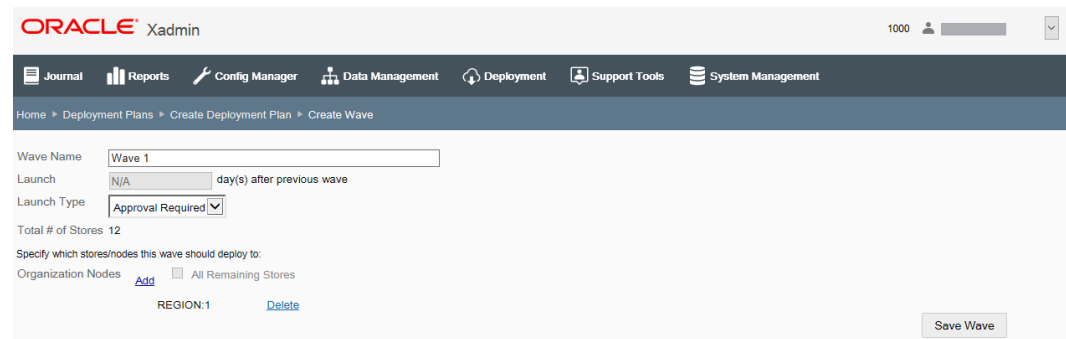
**Note:**

The nodes returned in this list are filtered based on the Scope you selected for the Plan. Store collections are not included in this list.

- c. Click **OK**.

The selected store/node is listed on the Create Wave page along with a Delete link. If needed, you can click **Delete** to remove the store/node from the Wave.

**Figure 7-14** Wave 1 - First Store/Node Added Example



6. [OPTIONAL] Repeat step 5 to add additional stores/nodes to this Wave.
7. After adding all stores/nodes to this Wave, click **Save Wave**. The Wave is added to the Deployment Plan and you are returned to the Create Deployment Plan page.

About Wave Validation:

The same node cannot be selected in multiple Waves (for example, District 1 in Wave 1 and District 1 in Wave 2). If you try to add an org node in multiple Waves, a message

displays. Click **OK** to close the message box and then click **Delete** to remove the duplicate Organization Node from the Wave.

Overlap within a Wave or between Waves is not allowed. If you try to add overlapping stores/nodes between two waves, a message displays. Click **Yes** to continue. Click **No** to return to the Create Wave page and then click **Delete** to remove the duplicate store from the Wave.

8. [OPTIONAL] To create additional Waves for the Deployment Plan, return to step 4 on page 10. Repeat as often as needed.
  - The next wave defaults to the next higher number, for example, Wave 2 follows Wave 1.
  - Enter the number of days this wave should be launched after the previous wave. For example, schedule Wave 2 to launch 7 days after Wave 1 is launched, and schedule Wave 3 to launch 5 days after Wave 2 is launched, and so on.
  - Select the launch type, Approval Required or Automatic.
9. When all Waves have been added to the Deployment Plan, click **Save Plan** to save all plan changes and return to the Deployment Plans page.

About Deployment Plan Validation:

If the Deployment Plan does not cover all stores within the selected scope, a message displays. Click **Yes** to save the plan even though not all stores in the selected scope are included. Click **No** to return to the Create Deployment Plan where you can make changes as needed.

10. The Deployment Plans page displays information about each plan.

**Figure 7-15 Deployment Plans Page**

Plan ID	Plan Name	Security Scope	# of Waves	Created On	Description
3	Plan 300	STORE:9901	1	Sep 14, 2018	Various Updates for Store

**Table 7-6 Deployment Plans Fields**

Field	Description
Plan ID	The auto-generated plan Identifier.
Plan Name	The name of the plan.
Security Scope	The target level (store or org node) for this plan.
# of Waves	The number of waves in the Deployment Plan.
Created On	The date the plan was created.
Description	The plan description.
Delete Icon	See <a href="#">Deleting an Deployment Plan and Waves</a> below.

## Deleting an Deployment Plan and Waves

1. From the Oracle Retail Xstore Office menu, select **Deployment - Deployment Plans**, or click the Deployment Plans link in the Deployment Manager panel.
2. At the Deployment Plans page, click the Delete icon to delete a plan.
3. When prompted, click **Yes** to delete the selected plan and all of its waves.

## Deleting a Wave from a Plan

1. From the Oracle Retail Xstore Office menu, select **Deployment - Deployment Plans**, or click the Deployment Plans link in the Deployment Manager panel.
2. At the Deployment Plans page, select a Deployment Plan from the list of plans.
3. With the Waves page displayed, click the Delete icon to delete a selected Wave.
4. When prompted, click **Yes** to delete the selected wave.

## Editing a Deployment Wave and Plan

Editing a Deployment Wave and Plan is similar to the process used to create a new Deployment Wave and Plan.

See [Creating a Deployment Plan](#) for more information about the fields on the Create Deployment Plan and Create Wave page.

1. From the Oracle Retail Xstore Office menu, select **Deployment - Deployment Plans**, or click the Deployment Plans link in the Deployment Manager panel.
2. At the Deployment Plans page, select a plan from the list.
3. Edit the Wave information as needed:
  - a. Select a Wave from the list and edit the fields as needed.
  - b. To add a Wave, select **Add New** to add a new Wave to the Plan.

 **Note:**

If all stores are covered in this plan, the **Add New** option will not be available.

- c. Click **Save Wave** to save your changes.
4. If needed, edit the Plan information.
  5. Click **Save Plan** to save all plan changes and return to the Deployment Plans page.

## Email Notifications

Set up an email notification list for emails to be sent for Wave Approval reminders and Wave Approval waiting notifications. The Approval Needed email notification will be sent out a configurable number of days before the projected launch date of a wave that is launch type Approval Required

The number of days is set up in Oracle Retail Xstore Office Configuration (Number of Days Before Deployment Wave to Send Notification). See [System Management, Oracle Retail Xstore Office Configuration Options](#).

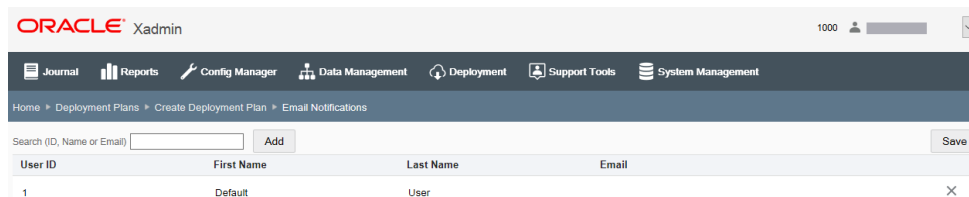
A Wave On Hold email notification will be sent out when the projected launch date has passed and a wave is still waiting to be approved.

The email includes a link that will direct the recipient to the Deployment Summary page for the deployment that needs approval. See [Figure 7-17](#) for a sample email message.

Perform the following steps to add and remove users from the Email Notification list of a Deployment Plan.

1. From the Oracle Retail Xstore Office menu, select **Deployment - Deployment Plans**, or click the Deployment Plans link in the Deployment Manager panel.
2. At the Deployment Plans page, click **Add New** to create a new Deployment Plan or select a Deployment Plan from the list.
3. At the Create Deployment Plan page ([Figure 7-11](#)), click the Email Notifications Edit link.
4. At the Email Notifications page, add or remove email information as needed:

**Figure 7-16 Email Notifications Page**



 **Note:**

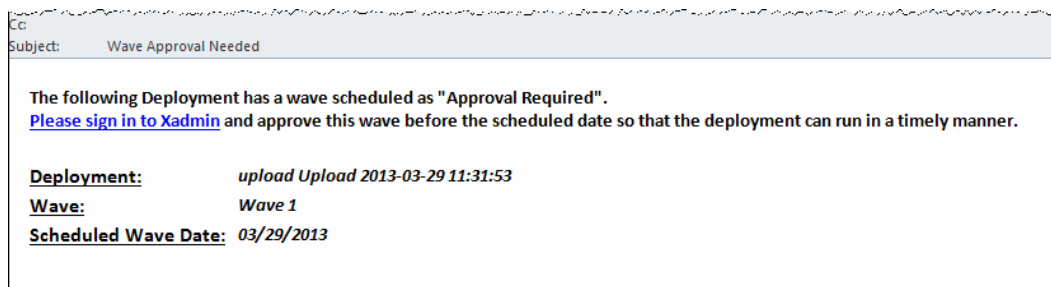
Email addresses listed in the search results are set up in System - Xadmin Users - Users and Security Access. See [Roles, Users, and Security Access, Admin Users - Using Roles to Grant Access to Oracle Retail Xstore Office](#) for more information.

To add a new user email to the Deployment Plan:

- a. Enter search information (ID, Name or Email) in the Search field to find the user's email.
- b. Select the email from the list, then click **Add**.

To remove a user email from the Deployment Plan, click the Delete icon associated with the email you want to remove.

5. Click **Save**.
6. Click **Save Plan** to save changes to the plan.

**Figure 7-17 Approval Needed Email Notification Example**

## Viewing Deployments

The current status of all deployments made from Oracle Retail Xstore Office can be tracked down to the store level. A drill-down style interface is provided to view summary level data for each deployment, down to the status of delivering and loading each update at each target store.

1. From the Oracle Retail Xstore Office menu, select **Deployment - View Deployments**, or click the View Deployments link in the Deployment Manager panel.
2. At the Deployments page, enter criteria for the Deployment you are searching for and then click **Search**.

### Note:

To return a list of all deployments, leave the fields blank and click **Search**. To view additional deployments, select a date range from the View More Deployments drop-down list.

The Deployments page shows the summary list of deployments. By default, this list is sorted with the latest deployment shown at the top. Click on a field heading ( ) to re-sort the list as needed.

**Figure 7-18 Deployments Page - Search Results**

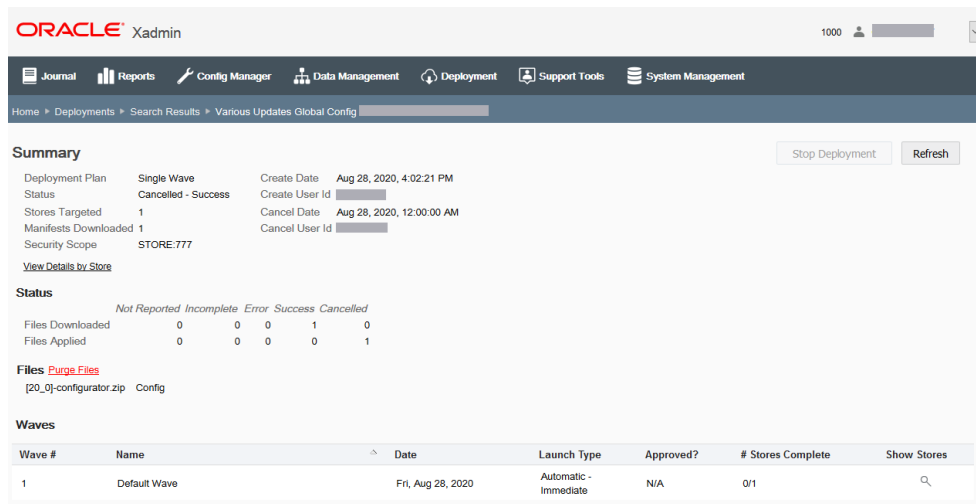
ID	Name	Type	Plan	Launch Date	Waves Complete	Status
6	Delete Store/102 Config v.1 2018-07-19 03:02:36	Configurator	Single Wave	Jul 19, 2018	0 out of 1	Scheduled
5	Multiple Data Changes	Data Manager	Single Wave	Jul 19, 2018	1 out of 1	Complete
4	Vendor	Data Manager	Single Wave	Jul 19, 2018	1 out of 1	Complete
2	Deploy Reason Code Changes - Single Deployment	Configurator	Single Wave	Jul 19, 2018	0 out of 1	In Process

 **Note:**

Deployment information is stored in the `dpl_deployment` database table.  
The "v.x" designation in the deployment name indicates the config version for this set of configurations.

- Deployment ID - The auto-assigned deployment identifier.
  - Name - The deployment name.
  - Type - The deployment type; Configurator, Data Manager, File Upload, or Auto Deploy.
  - Plan - The deployment plan name.
  - Launch Date - The deployment launch date.
  - Waves Complete - The number of waves completed compared to the total number scheduled.
  - Status - The deployment status; Approval Required, Complete, In Process, Cancelled, Scheduled, Error
3. Select a row in the Deployments page summary list (Figure 7-17) to view additional information about the selected deployment.
  4. The Deployment Summary page displays and shows the current status of the selected deployment as reported by all of the stores via Oracle Retail Xenvironment.

**Figure 7-19 Deployment Summary Page**



**Summary**

Deployment Plan	Single Wave	Create Date	Aug 28, 2020, 4:02:21 PM
Status	Cancelled - Success	Create User Id	[REDACTED]
Stores Targeted	1	Cancel Date	Aug 28, 2020, 12:00:00 AM
Manifests Downloaded	1	Cancel User Id	[REDACTED]
Security Scope	STORE:777		

[View Details by Store](#)


**Status**

	<i>Not Reported</i>	<i>Incomplete</i>	<i>Error</i>	<i>Success</i>	<i>Cancelled</i>
Files Downloaded	0	0	0	1	0
Files Applied	0	0	0	0	1

**Files** [Purge Files](#)

[20\_0]-configurator.zip Config

**Waves**

Wave #	Name	Date	Launch Type	Approved?	# Stores Complete	Show Stores
1	Default Wave	Fri, Aug 28, 2020	Automatic - Immediate	N/A	0/1	

The information shown here is a collection of aggregate counts for all of the possible deployment statuses; such as the number of stores that have downloaded the manifest, the number of stores that have downloaded the deployment's files (successfully or in error), and the number of stores that have applied the deployment's files (successfully or in error). If needed, click **Refresh** at any time to update the page and see current changes.

Perform the following functions as needed:

- Approve Waves - If approval is required before a Wave can begin, an authorized user must review and approve the Wave. See [Approving a Wave](#).
- View store details - This page also provides a link to a per-store list of status data (View Details By Store). See [Viewing Detail By Store](#) for more information.
- Stop or cancel a deployment

A Stop Deployment button on this page is available once the deployment is under way or as soon as the first wave's date is today. Stop Deployment will cancel the deployment before the next wave begins. See [To Stop a Deployment](#).

A **Cancel Deployment** button on this page is only available if you are viewing a deployment before the deployment has started. Once the deployment is under way it cannot be cancelled. See [Cancelling a Deployment](#) for more information about cancelling a deployment.

- Purge Files - If applicable, a Purge Files link is available to delete the files. See [Purging Files](#).

**Table 7-7 Deployment Summary Section - Fields**

Field	Description
Deployment Plan	The name of the plan that used in this deployment, It will contain Single Wave if the Single Wave option was selected.
Status	The deployment status: Error, Complete, In process, Approval Required, Scheduled, Cancelled
Stores Targeted	The total number of stores targeted in all waves.
Manifests Downloaded	The number of stores that have downloaded the manifest. There will be one manifest per store.
Security Scope	The hierarchy node level of the deployment.
Create Date	The date the deployment was created.
Create User ID	The user who created this deployment.
Cancel Date	The date the deployment was cancelled. This field is only displayed if the deployment was stopped or cancelled. See <a href="#">Cancelling a Deployment</a> and <a href="#">To Stop a Deployment</a> .
Cancel User ID	The user who cancelled the deployment. This field is only displayed if the deployment was stopped or cancelled. See <a href="#">Cancelling a Deployment</a> and <a href="#">To Stop a Deployment</a> .
View Details By Store link	Opens a window showing a per-store list of status data. See <a href="#">Viewing Detail By Store</a> .

**Table 7-8 Status Section - File Status Code**

File Status Code	Description
Files Downloaded	
Not Reported	No status available yet.
Incomplete	Only occurs if multiple files are downloaded and the files currently have different statuses during the download process.
Error	File download errors.



**Table 7-8 (Cont.) Status Section - File Status Code**

File Status Code	Description
Success	File download successful.
Cancelled	File download cancelled.
Files Applied	
Not Reported	No status available yet.
Incomplete	Only occurs if multiple files are downloaded and the files currently have different statuses during the application process.
Error	File application process has errors.
Success	Files applied successfully.
Cancelled	File applied cancelled.

**Table 7-9 Files Section - File Categories and File Types**

File Category	File Type	Description
Config	configurator.zip	The zip file contains the manifest and configuration information.
Compressed data	datamanager.zip	The zip file contains the manifest and data manager information.
Data	.mnt, .reo, .dat, .rep	The standard Dataloader files.
App update	updater.jar	The executable jar file contains software update information.
debit.txt	debit.txt	The debit bin file containing BIN range values for authorized card tenders.
CIP	.cip	Contains cipher keys information.
JRE/JCE	XST-jre-windows.zip XST-jce-windows.zip	Contains the JRE/JCE file types.
Purge Files link	See <a href="#">Purging Files</a> .	NA

**Table 7-10 Wave Section - Fields**

Field	Description
Wave #	The Wave number.
Name	The Wave name.
Date	The launch date.
Launch Type	The launch type; Approval Required or Automatic.
Approved?	For Automatic launch type, this does not apply. For Approval Required launch type, indicates whether or not the wave has been approved. See <a href="#">Approving a Wave</a> for more information about approving a wave.
# Stores Complete	The number of complete stores.

Table 7-10 (Cont.) Wave Section - Fields

Field	Description
Show Stores icon	Click the Show Stores icon to view detailed information about the files downloaded and files applied to the targeted stores for the Wave.

## Viewing Detail By Store

The Detail by Store page is accessed from the Deployment Summary page and displays a per-store list of status data.

- To view store details, click the View Details By Store link in the Deployment Summary page.

### Note:

By default, the initial page filter is set to show any errors. Use the filter selections to filter the records based on the status code values. If a value of 0 (zero) is associated with a status, the option to enable or disable it is not available since there are no records to filter.

Figure 7-20 Detail by Store Page - Targeted Store Detail

Store	Manifest Downloaded	Files Downloaded	Files Applied
101	Jul 19, 2018, 8:58:21 AM	Success	Success

These status codes show each individual store's deployment statuses and are an aggregation of all the statuses across all the files defined in the deployment.

- Manifest Downloaded - If the manifest was downloaded, the date and time will be shown in this column. If the manifest has not been downloaded, this column will show Not Reported.
- Files Downloaded - If the file(s) were downloaded successfully, Success will be shown in this column. If the file(s) were downloaded with an error, Error will be shown in this column. If the file(s) have not been downloaded, Not Reported will be shown in this column. If multiple files are currently being downloaded and the files have different statuses at this moment, Incomplete will be shown in this column. If the download has been cancelled, Cancelled will be shown in this column.
- Files Applied - If the file(s) were applied successfully, Success will be shown in this column. If the file(s) were applied with an error, Error will be shown in this column. If the file(s) have not been applied, Not Reported will be shown in this column. If

multiple files are currently being applied and the files have different statuses at this moment, Incomplete will be shown in this column. If the file(s) applied have been cancelled, Cancelled will be shown in this column.

2. Use the filters to view data as needed.
3. Select a row in the list to view additional information about a specific store.

**Figure 7-21 Store Detail Window**

**Store #777**

**Deployment Manifest**  
Downloaded Time Aug 28, 2020, 4:03:01 PM

<b>[20_0]-configurator.zip</b>		Details
Downloaded Status	Success	File downloaded.
Time	Aug 28, 2020, 4:03:01 PM	
Applied Status	Cancelled	Details
Time	Sep 3, 2020, 2:39:34 PM	Deployment cancelled, file not applied.

Previous Next

 **Note:**

If an error is reported, detailed information about the error is provided in the Details section of the Store Detail window.

4. If needed, use the **Previous** and **Next** buttons to view detail for other stores in the list.
5. Click the Close icon to close the window and return to the Detail by Store page.

## Approving a Wave

For Approval Required waves, perform the following steps to approve a wave.

1. At the Deployment Summary page (Figure 7-19), select the row of the Wave that needs to be approved.
2. At the Wave Approval window, click the Approve link to change the approval status to approved.

**Figure 7-22 Wave Approval Window - Approve Wave**

**Wave 1**

Target Date

Permission **Approval Required**

Approved? **No** [Approve?](#)

# Stores Complete **0** out of **1**

3. Click **Save**. The Wave Approval Window closes and the system returns to the Deployment Summary page where the Wave now shows it has been approved.

## Unapproving a Wave

### Note:

You cannot unapprove a Wave if the wave has started, for example, if the target date is today's date. Only a wave that has not started yet can be unapproved.

1. At the Deployment Summary page (Figure 7-19), select the row of the Wave that needs to be unapproved.
2. At the Wave Approval window, click the Unapprove link to change the approval status to unapproved.

**Figure 7-23 Wave Approval Window - Unapprove Wave**

**Wave 1**

Target Date

Permission **Approval Required**

Approved? **Yes** Approved Default User 9/17/18, 10:52 AM [Unapprove?](#)

# Stores Complete **0** out of **1**

3. Click **Save**. The Wave Approval Window closes and the system returns to the Deployment Summary page where the Wave now shows it has not been approved.

Once a wave has been unapproved, the date can be changed and then the wave can be approved again.

## Purging Files

Use this option to purge old deployment files from the Apache Server. This option is only available for Deployments that have a status of Complete or Cancelled.

1. At the Deployment Summary page, click the Purge Files link.

**Figure 7-24** Deployment Summary Page

**Summary**

Deployment Plan: Single Wave  
 Status: Cancelled - Success  
 Stores Targeted: 1  
 Manifests Downloaded: 1  
 Security Scope: STORE:777

Create Date: Aug 28, 2020, 4:02:21 PM  
 Create User Id: [redacted]  
 Cancel Date: Aug 28, 2020, 12:00:00 AM  
 Cancel User Id: [redacted]

**Status**

	Not Reported	Incomplete	Error	Success	Cancelled
Files Downloaded	0	0	0	1	0
Files Applied	0	0	0	0	1

**Files** [Purge Files](#)

[20\_0]-configurator.zip Config

**Waves**

Wave #	Name	Date	Launch Type	Approved?	# Stores Complete	Show Stores
1	Default Wave	Fri, Aug 28, 2020	Automatic - Immediate	N/A	0/1	<a href="#">Show Stores</a>

2. When prompted, click **Yes** to confirm you want to delete the files from Apache Server.
3. Click **OK** to close the Successful Purge window and the Purge Status is updated to Success.

At the Deployments page, the status indicates the deployment file has been purged.

## To Stop a Deployment

Follow the instructions in this section if you need to stop a deployment that is under way. The Stop Deployment process will cancel the deployment before the next wave begins.

### Note:

There is no way to determine where within a wave (for example, which store it is on) the deployment will be stopped. Once the **Stop Deployment** button is selected, the wave is stopped immediately and the remaining stores will not be updated.

Once a deployment has been stopped it cannot be restarted. It must be re-created to run again.

1. From the Oracle Retail Xstore Office menu, select **Deployment - View Deployments** or click the View Deployments link in the Deployment Manager panel.
2. At the Deployments page select the deployment you want to stop from the summary list of deployments.
3. At the Deployment Summary page, click **Stop Deployment**.

**Figure 7-25 Deployment Summary Page - Stop Deployment**

The screenshot shows the Oracle Xadmin interface. The top navigation bar includes Journal, Reports, Config Manager, Data Management, Deployment, Support Tools, and System Management. The breadcrumb trail is Home > Deployments > Search Results > STORE:605-Multiple Data Changes. The main content area is titled 'Summary' and includes a 'Stop Deployment' button and a 'Refresh' button. The summary details are as follows:

Deployment Plan	Single Wave	Create Date	Jul 27, 2018, 4:17:46 PM
Status	Scheduled - Success	Create User Id	1
Stores Targeted	1		
Manifests Downloaded	0		
Security Scope	STORE:605		

Below the summary, there is a 'View Details by Store' link. The 'Status' section shows a table with columns: Not Reported, Incomplete, Error, Success. The 'Files' section shows a file named 'datamanager.zip' with the description 'Compressed data'. The 'Waves' section contains a table with the following data:

Wave #	Name	Date	Launch Type	Approved?	# Stores Complete	Show Stores
1	Default Wave	Fri, Jul 27, 2018	Automatic - Immediate	N/A	0/1	

4. When prompted, select **Yes** to stop the deployment, and click **OK** when prompted to acknowledge the deployment has been stopped.

If you decide not to stop the deployment by clicking **No**, you are returned to the Deployment Summary page without making any changes.

## Cancelling a Deployment



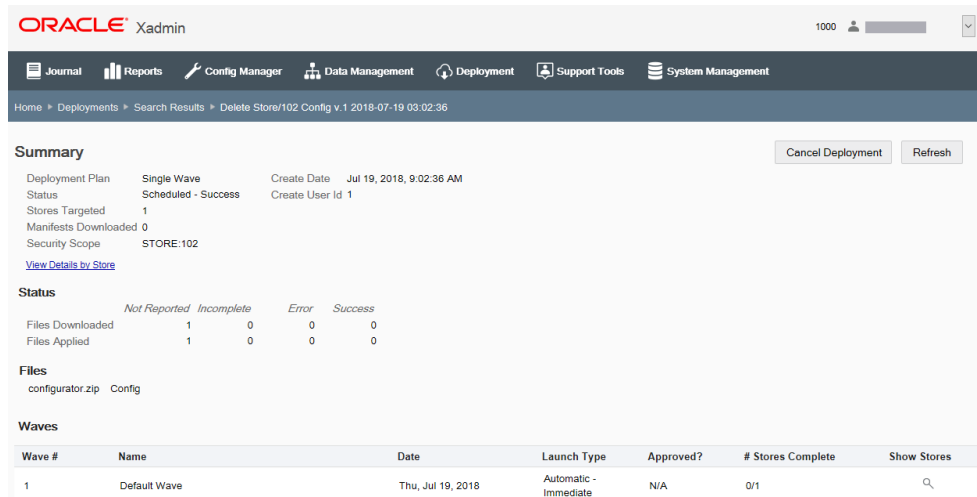
### Note:

Once a deployment has been cancelled it cannot be restarted. It must be re-created to run again.

Follow the instructions in this section if you need to cancel a deployment. You can only cancel a deployment if no manifests have been downloaded, and all statuses are unreported.

1. From the Oracle Retail Xstore Office menu, select **Deployment - View Deployments** or click the View Deployments link in the Deployment Manager panel.
2. At the Deployments page select the deployment you want to cancel from the summary list of deployments.
3. At the Deployment Summary page, click **Cancel Deployment**.

Figure 7-26 Deployment Summary Page - Cancel Deployment Example



**Note:**

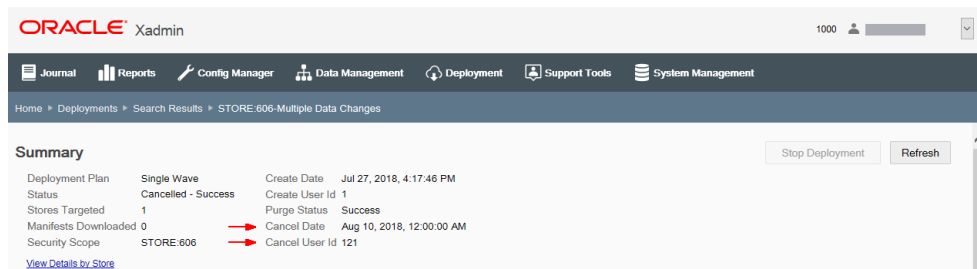
The **Cancel Deployment** button will only be available if no manifests have been downloaded and all statuses are unreported for the deployment. Once the Deployment is under way, the **Stop Deployment** button will be available here. The Stop Deployment option cancels the deployment before the next wave begins.

4. When prompted, select **Yes** to cancel the deployment, and click **OK** when prompted to acknowledge the deployment has been cancelled.

If you decide not to cancel the deployment by clicking **No**, you are returned to the Deployment Summary page without making any changes.

5. The date the deployment was cancelled and the user who cancelled the deployment are shown on the Deployment Summary page.

Figure 7-27 Deployment Summary Page - Cancelled Deployment



## Automatic External File Delivery

The Automatic External File Delivery feature provides the ability to have any standard DataLoader files (.dat, .mnt, .reo, .rep) left by any external system in a file drop directory so the files can be deployed to stores.

Oracle Retail Xstore Office monitors a specific directory for files. This directory is configured in **System - Xadmin Settings - Directory for Automatically Deployed Data Files** (AutoFileTransferDirectory).

The interval at which the directory is checked is also configured in **System - Oracle Retail Xstore Office Settings - Detection Interval for Automatically Deployed Data Files** (AutoFileTransferSchedulerInterval). See [System Management, Oracle Retail Xstore Office Configuration Options](#).

Any files placed in the auto directory, in the appropriate **org** directory, (/ filetransfer/auto/org\${organizationId}/) will be picked up and a deployment will be created for that file. No user intervention is required to move the files to the stores.

The order in which files are consumed by Oracle Retail Xstore Office is not guaranteed. If a specific ordering of records across multiple files is required, Oracle recommends that those files be combined in a single file, in the appropriate order, before dropping them off in this directory.

## Setting File Delivery Details

Each file must contain an XML header line that will dictate when and where the file is delivered.

```
<Header line_count="3" download_id="configurator::7::72::0"
application_date="2013-05-26" target_org_node="STORE:102"
deployment_name="specified_name" download_time="IMMEDIATE" apply_immediately="true" />
```

### Line Count [optional]

The `line_count` attribute is used to indicate how many lines of data are in the file (not including the header). If it is not present, the DataLoader will not validate total line count when loading the file, but will still load the file.

### Download ID

The `download_id` attribute is used to identify the download.

### Application Date

The `application_date` attribute is used to determine the date on which the file will be deployed. If the application date attribute is not present, the date that the file is picked up will be used which means the file will be deployed on the same day.

### Target Org Node

The `target_org_node` attribute is used to determine to what org node or store collection the file will be deployed. Its format is `<org code>:<org value>` (for example, `STORE:102`) or `<CollectionName>` (for example, `My Collection`). If the target org node attribute is not present, `**` will be used which means the file will be delivered to all stores in the organization.

### Deployment Name

If the `deployment_name` field is populated, the value will be used as the name for the deployment, otherwise the auto-suggestion name will be used.



## Download Time

The `download_time` attribute is used to indicate when the file will be downloaded. Possible values are `IMMEDIATE` and `STORE_CLOSE`.

If a deployment is scheduled for immediate download, Oracle Retail Xenvironment will begin to download the file immediately. If a deployment is scheduled for download during the daily maintenance, Oracle Retail Xenvironment will wait until the nightly closing process is initiated to begin downloading the file.

If `download_time` is not present, the deployment will be scheduled with `STORE_CLOSE`.

## Apply Immediately

The `apply_immediately` attribute is used to indicate when the file will be applied. Possible values are `true` and `false`. If set to `true`, the file is loaded immediately. If set to `false`, the file is scheduled to be applied during the closing process. If `apply_immediately` is not present, the deployment will be scheduled with `false`. See [Appendix: About Deployments](#) for more information.

# 8

## Electronic Journal

The Electronic Journal component is used to view transactional data from the Xcenter (a part of Oracle Retail Xstore Office) database in a receipt format. The Oracle Retail Xstore Office Electronic Journal is similar to the Oracle Retail Xstore Point-of-Service POS Electronic Journal, and provides the ability to search for and review transactional activity within your store hierarchy. This application runs against the Xcenter database and provides visibility for transactions across all stores. The search capabilities allow you to quickly locate any transaction across the chain. You can view the detail in a receipt format that mirrors the receipt generated at the store, including the customer's signature (if captured). This feature is commonly used for credit dispute (chargeback) resolution, as well as loss prevention investigation.

Additionally, you can reprint the invoices and reports that are associated to the current transaction through the Electronic Journal function.

### About this Chapter

This chapter contains instructions on starting the Electronic Journal function and searching for transaction data.

### Using the Xcenter Electronic Journal

1. From the Oracle Retail Xstore Office menu, select **Journal - Electronic Journal**, or click the Electronic Journal link in the Reports panel.

The Electronic Journal page displays, showing the search parameters.

2. Enter your search criteria to limit the amount of data returned. The following search parameters are available:

- Org Node - Enter a node ID or click the Globe icon to select a node from the hierarchy tree to restrict the search to a store (or stores) in the organization. [REQUIRED]
- Register # - Enter the identifier for a specific register or leave blank for all registers.
- Customer Number - Enter a customer's ID number to view information about a specific customer, or leave blank for all customers.
- Customer Last Name - Enter a customer's last name to search for and view information about a specific customer, or leave blank for all customers.
- Credit Card Last 4 # - Enter the last 4 digits of the credit card.

 **Note:**

Entry is restricted to only 4 digits.

- Tender Type - Select a tender from the list to search for a specific type of tender, or accept the default value <ALL> to view information for all tenders.
  - Transaction Type - Select the type of transaction from the drop-down list; the default is Retail Sale. The value <ALL> allows you to search for all transaction types.
  - Business Date - Enter a start date and end date, accept the default, or click the calendar icon to choose the dates. The default is the previous 30 days.
  - Transaction ID - Enter a transaction identifier for a specific transaction, a range of transactions, or leave these fields blank to view information for all transactions. Enter the same transaction number in both fields to locate a specific transaction number.
  - Cashier ID - Enter the identifier for the ringing associate's ID, a range of ringing associate IDs, or leave blank for all associates.
  - Fiscal Number - Enter the fiscal number.
3. Click the **Search** button to execute the search:
    - The information returned from the search shows the store ID, register ID, transaction ID, transaction type, transaction status, cashier ID, business date, customer name, and transaction total.
    - The first 200 results are displayed on the page. If the desired result is not listed, click Electronic Journal in the breadcrumb at the top of the page to return to the search parameters. Refine the search criteria and search again.
    - A sorting component is available for a column, when applicable.
    - If a single transaction matches the search criteria, only one row is returned.
  4. Click a transaction in the list to view additional information.

**Figure 8-1 Electronic Journal Viewer Page - Transaction List**

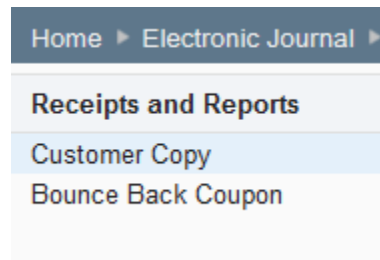
The screenshot shows the Oracle Xadmin interface. At the top, there is a navigation bar with icons for Journal, Reports, Config Manager, Data Management, Deployment, Support Tools, and System Management. Below the navigation bar is a breadcrumb trail: Home > Electronic Journal > REGION:1. The main content area displays a table with the following columns: Store, Register #, Transaction ID, Transaction Type, Status, Cashier ID, Date, Customer Name, and Total. The table contains seven rows of transaction data.

Store	Register #	Transaction ID	Transaction Type	Status	Cashier ID	Date	Customer Name	Total
101	1	657	Retail Sale	Complete	100	Jul 19, 2018	Teresa Hall	\$1.49
101	1	524	Retail Sale	Complete	100	Jul 19, 2018	Teresa Hall	-\$27.00
101	1	314	Retail Sale	Complete	100	Jul 19, 2018	Teresa Hall	\$5.00
101	1	311	Retail Sale	Complete	100	Jul 19, 2018	Teresa Hall	\$49.00
101	1	156	Retail Sale	Complete	100	Jul 19, 2018	Teresa Hall	\$26.60
101	1	124	Retail Sale	Complete	100	Jul 19, 2018	Teresa Hall	\$63.90
101	1	123	Retail Sale	Complete	100	Jul 19, 2018	Teresa Hall	\$0.00

5. If multiple receipt and report types exist for this transaction, select a receipt/reports type from the list.

For example, if you selected a Store Close transaction and a Daily Report is attached to it, select Daily Report to view and reprint it.

**Figure 8-2 Receipt and Reports Type List**



6. The selected receipt or report displays. Choose one of the following options:
  - Click the **Print** button to print a copy of this receipt or report.
  - Select a different receipt or report type from the list (Figure 8-2) to view a different receipt or report from this transaction.
  - Click the breadcrumbs to navigate to a previous page:
    - To return to the transaction list for this location, click the location breadcrumb (for example, `STORE:101`).
    - To return to the Ejournal search parameters, click the Electronic Journal breadcrumb.
    - To return to the Home page, click the Home breadcrumb.

# 9

## Reports

The Reports component is used to run and view Oracle Retail Xstore Point-of-Service reports against the Xcenter (central) database. Oracle Retail Xstore Office Reports provides a wide variety of reports to help you monitor and analyze a store's operations and sales. The reports are grouped by functionality, similar to their configuration in base Oracle Retail Xstore Point-of-Service POS reporting.

### About this Chapter

This chapter contains the following sections:

- For information on starting the Reports function, see [Accessing and Running Oracle Retail Xstore Office Reports](#).
- For a list of reports, see [Available Reports By Category](#)

### Where To Look For More Information

A system configuration allows you to turn off and on any of the valid file format types available to be used when viewing/saving reports. You can also select the default format to be selected from the list of enabled file formats.

For instructions on specifying the report formats to be available to the user, see [System Management](#), section [Reports Category](#).

## Accessing and Running Oracle Retail Xstore Office Reports



#### Note:

Only reports the user has privileges to access (based on the user's role) will be available.

1. From the Oracle Retail Xstore Office menu select Reports - Reporting category option (Flash Sales Summary or All Reports), or from the Reports panel, click the Flash Sales Summary link or the Daily Sales & Cash Report link.
  - If you selected the All Reports link, use the report tree structure to select the specific report, then continue with step 2 below.
  - If you selected the Flash Sales Summary link or the Daily Sales & Cash Report link, the specific report parameters page displays. Continue with step 2 below.
  - If you selected the Electronic Journal link in the Reports panel, refer to [Electronic Journal](#) for more information.
2. Enter the report parameters to be used to run the report.

 **Note:**

The report parameters are the same options that are available when running the identical report within Oracle Retail Xstore Point-of-Service POS, and are specific to each report.

Refer to the *Oracle Retail Xstore Point-of-Service Reports Guide* for detailed information about the standard reports available in Oracle Retail Xstore Office.

3. In addition to the reporting parameters, specify an output type:

 **Note:**

The output types available here are configured in Oracle Retail Xstore Office Settings. See [System Management](#), [Reports Category](#).

- PDF - Portable Document Format
- HTML - HyperText Markup Language (The predominant markup language for web pages.)
- CSV - Comma Separated Values (A common import and export format for spreadsheet layout).
- XLS - MS Excel
- XLSX - MS Excel 2007 or newer
- PPTX - MS PowerPoint
- RTF - Rich Text Format
- DOCX - MS Word

 **Note:**

Known Firefox Limitations

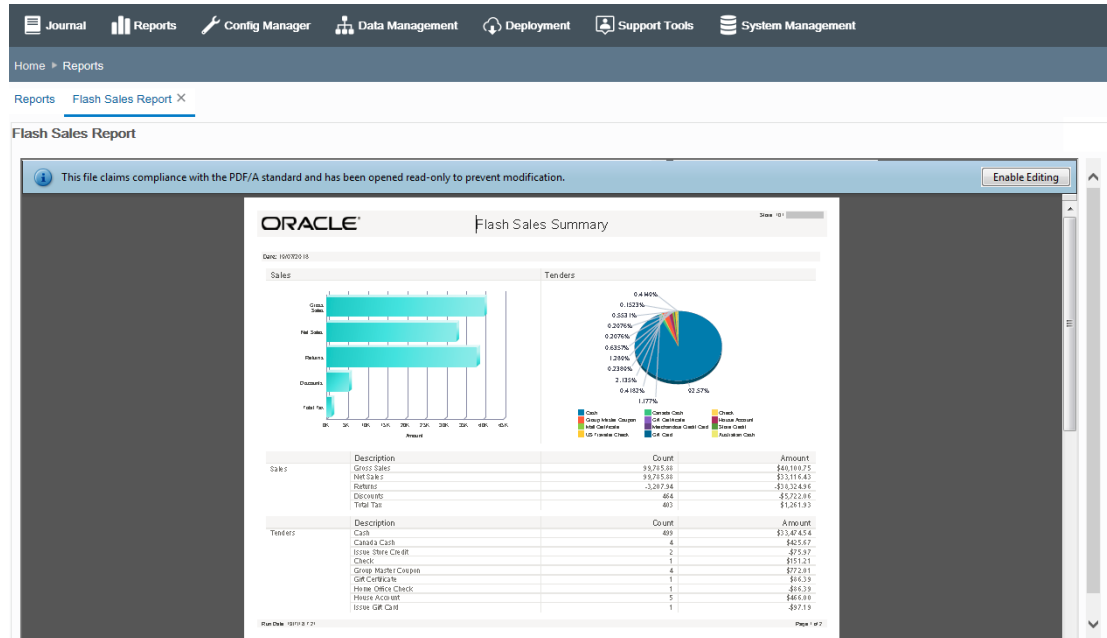
XLSX, PPTX, and DOCX output types may not open properly in FireFox. The work-around for this is as follows:

- Right-click on the Click To Download Report link.
- Select **save as...** and save the report to the local file system.
- Open the report outside of the browser.

4. Click **Run Report** to create the report. The report will be displayed in the format you selected, or you may need to click the Download link ( ) when applicable.

# Report Example

Figure 9-1 Flash Sales Report Example - PDF Format



- To close the report, click the close icon on the tab.
- To return to the report parameters, click the Reports tab.

## Available Reports By Category

The following reports are available in base Oracle Retail Xstore Office. Refer to the *Oracle Retail Xstore Point-of-Service Reports Guide* for detailed information about these reports.

### Dashboard Report

Dashboard

### Custom Reports

- Custom Report(s)

If a custom report is uploaded the Custom Reports category will be created. All new custom reports uploaded to the application will be accessible in the Custom Reports category.

### Flash Sales Reports Category

- Flash Sales Report

## Sales Reports Category

- Daily Sales & Cash Report
- Sales By Hour Report
- Sales By Hour Analysis Report
- Sales By Department Report
- Returned Merchandise Report
- Best Sellers Report
- Credit Card Report
- Daily Sales Report

## Stock Valuation Report

- WAC Reports
  - WAC Stock Valuation Report
  - WAC Detail Report
- PWAC Reports
  - PWAC Stock Valuation Report
  - PWAC Detail Report

## Airport Reports

- Airport Authority Report

## Transaction Audit Reports

- No Sale Report
- Price Override Report
- Line Void Report
- Post Void Transaction Report
- Suspended Transaction Report
- Cancelled Transaction Report
- Gift Certificate Report
- Tax Exemption Report

## Inventory Reports Category

- Shipping Exception Report
- Receiving Exception Report
- Inventory Stock Cost
- Receiving Report



## Employee Schedule Reports Category

- Employee Performance Report

## Customer Account Reports Category

- Layaway Aging Report
- Layaway Account Activity Report
- Customer Account Activity Summary Report

## Misc Reports Category

- Journal Report
- Store Locations Report
- Customer List Report
- Special Orders Report
- Price Change Report
- Item List Report
- Employee Tasks Report

## Dashboard

Use the dashboard report to view sale data for individual stores. The dashboard shows enterprise data for a single store, as a static page. If you want to refresh the data, you need to re-run the report.

The header displays the store number, the store name as well as the current business date.

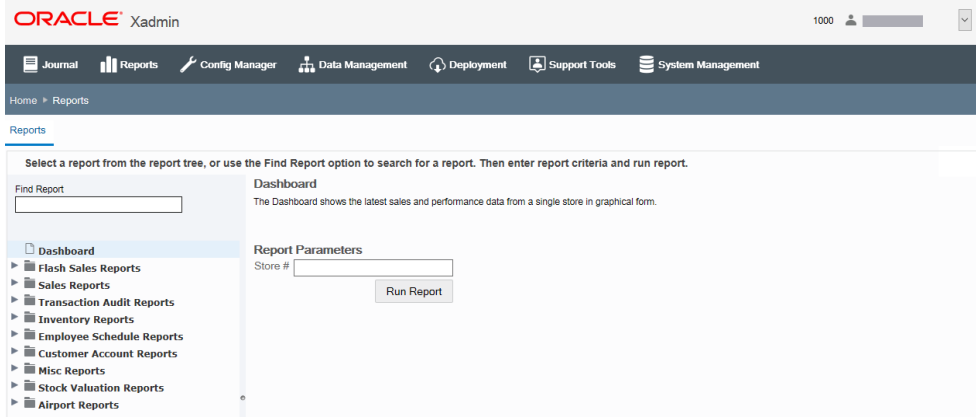
The following data is displayed for the selected store:

- Total Sales (Gross Sales, Net Sales, Returns, Discounts, Total Tax)
- Sales by Department (top 10)
- Sales by Hour
- Number of Items (by hour)
- Number of Transactions (by hour)

To create the Dashboard report follow the steps below:

1. In the Oracle Retail Xstore Office, select **Reports** and then select **Dashboard**.

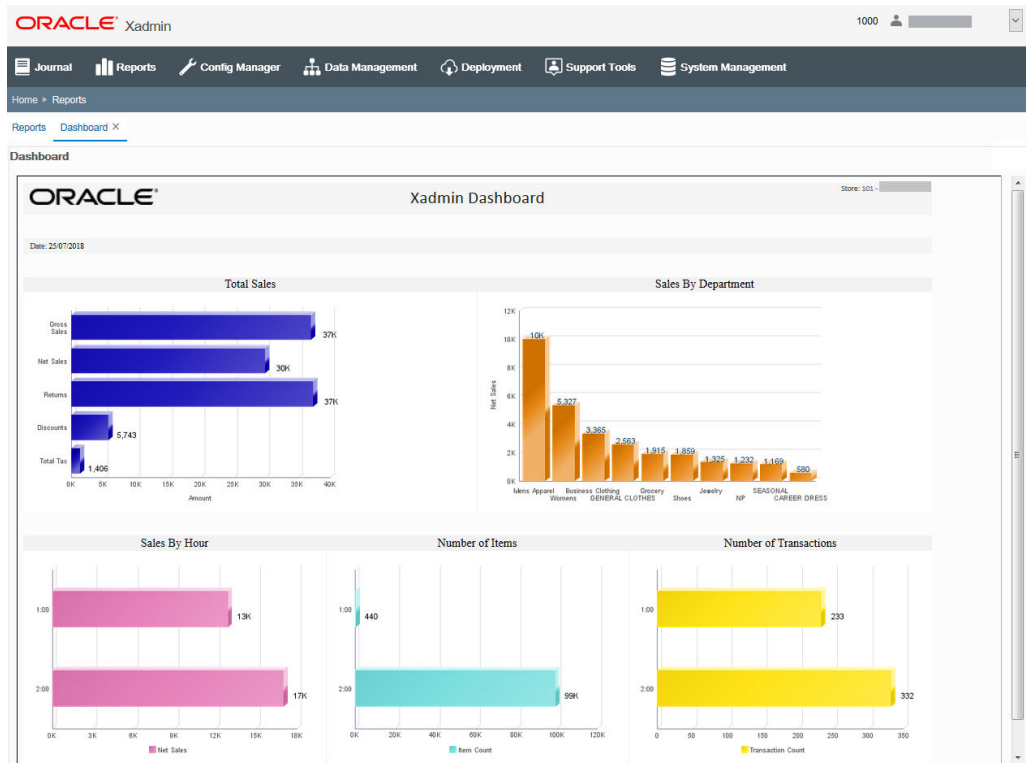
Figure 9-2 Reports - Dashboard



2. In the Store # field, enter the number of the store you want to create the report for.
3. Then click **Run Report**.

## Dashboard Report Example

Figure 9-3 Dashboard Report Example



# 10

## Support Tools

The Support Tools component allows you to view issues taking place at the store level, and to set up email alerts to be sent to the appropriate personnel when any issues occur. The Alert Console shows logged events for replication errors, connectivity errors, application errors, hardware errors, update errors, and version errors. Using Alert Settings it is also possible to customize the alert severity threshold level values for your organization, providing the ability to set your organization's tolerance levels for the various alert events. The Deployed Xstore Versions support tool allows you to view the Oracle Retail Xstore Point of Service versions deployed throughout your organization, in a pie chart view. You can quickly see the number of stores running each version of Oracle Retail Xstore Point-of-Service, and to get additional store-level information. The Publish PosLog Data support tool provides the ability to compile the PosLog data from within Xcenter (a part of Oracle Retail Xstore Office) and save it as a file to a specified location, or to rebroadcast the PosLog data to specified broadcasters in order to post to a 3rd party system (Oracle Retail Customer Engagement Cloud Services, Oracle Retail Order Management System Cloud Service, and so on) through platform independent technologies such as Web services. This allows you to manage this information centrally, without having to connect remotely to stores. The Replication Status support tool provides the ability to view and act on replication errors. Replication is the process used to copy and distribute data from one database to another, and to synchronize between the databases to maintain consistency.

### About this Chapter

- The Alert Console feature allows corporate users to view an Alerts console showing logged events for replication errors, connectivity errors, application errors, hardware errors, update errors, and version errors. See [About Alerts](#).
  - [Replication](#) - describes the logged events for replication errors.
  - [Connectivity](#) - describes the logged events for connectivity errors.
  - [Application](#) - describes the logged events for application errors.
  - [Hardware](#) - describes the logged events for hardware errors.
  - [Updates](#) - describes the logged events for update errors.
  - [Versioning](#) - describes the logged events for version errors
- The Alert Settings feature provides the ability to set up an email notification list to be used when critical alerts occur, and provides the ability to modify and customize the alert severity threshold values for your organization. For information about the Alert Settings feature, see [Alert Settings](#).
- The Deployed Xstore Versions feature shows Oracle Retail Xstore Point-of-Service version information by store in a pie chart format. For information about the Deployed Oracle Retail Xstore Point-of-Service Versions, see [Deployed Oracle Retail Xstore Point-of-Service Versions](#).
- The Publish PosLog Data feature provides the ability to publish transaction and related files from Xcenter as an alternative to polling existing files from the store. For information about publishing a PosLog, see [PosLog Publisher](#)

- The Replication Status feature provides the ability to view and act on replication errors reported here. For information about the Replication Status feature, see [Replication Status](#).

## Alert Console

The Alert Console feature allows corporate users to view an Alert page showing logged events for replication errors, connectivity errors, application errors, hardware errors, update errors, and version errors.

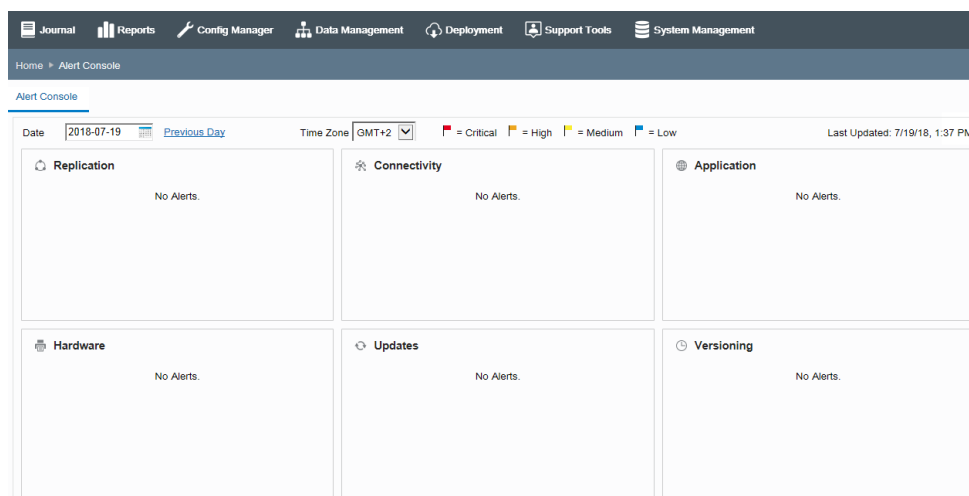
If you set up email alerts (see [To Set Up Critical Alert Email Recipient Addresses](#)), an email with critical alerts details will be sent to the designated recipients. To define severity-level thresholds, see [Alert Threshold Settings](#).

You must have the Alert Console privilege to use this feature.

1. From the Oracle Retail Xstore Office menu, select **Support Tools - Alert Console**, or click the Alert Console link in the Support Tools panel.
2. The initial Alert Console page provides summary-level information at a glance about any issues at the stores in your organization requiring your attention.

The system defaults to the current date and shows the date and time the Alerts Console was last updated.

**Figure 10-1 Alert Console Page - Business Date Field**



To review alerts from previous dates:

- enter the date in the Date field, or select a date from the calendar,
- or use the **Previous Day** and **Next** option.

## About Alerts

A background process is responsible for reviewing events published to Xcenter (a part of Oracle Retail Xstore Office) and determining whether to create a new alert, or update an existing alert based on currently configured severity thresholds and rules.

If there are any alerts, the console window will show the following information:

- The severity of the event: Critical, High, Medium, Low.
- The time the event was logged.
- The store where the event occurred.
- The type of event.
- The number (#) of times the event occurred.

**Figure 10-2 Alert Console With Alerts**

The screenshot shows the Oracle Xadmin Alert Console interface. The top navigation bar includes links for Journal, Reports, Config Manager, Data Management, Deployment, Support Tools, and System Management. The main content area is titled 'Alert Console' and displays a grid of alert categories. The 'Replication' category shows one alert: a Critical event at 08:22:52 on store 101, 'Replication Queue Block', occurring 200 times. The 'Connectivity' category shows three alerts: a Critical event at 08:32:21 on store 101, 'Database Offline', occurring 10 times; a Critical event at 08:31:17 on store 101, 'Xpay Offline', occurring 108 times; and a High event at 07:41:46 on store 102, 'Database Offline', occurring 3 times. The 'Application' category shows one alert: a Low event at 08:41:19 on store 101, 'Xenvironment Task', occurring 1 time. Other categories like Hardware, Updates, and Versioning show 'No Alerts'.

Category	Time	Store	Type	#
Replication	08:22:52	101	Replication Queue Block	200
Connectivity	08:32:21	101	Database Offline	10
	08:31:17	101	Xpay Offline	108
	07:41:46	102	Database Offline	3
Application	08:41:19	101	Xenvironment Task	1
Hardware	No Alerts.			
Updates	No Alerts.			
Versioning	No Alerts.			

## Replication

Click a logged event in the list to view additional details.

The logged events, "Xstore replication queue errors" and "Xstore replication backlog" and "Xcenter persistence failure" are sourced from Xcenter's `rpl_replication_data` table.

**Figure 10-3 Replication Logged Events Detail**

The screenshot displays the Oracle Alert Console interface. At the top, there are navigation tabs: Journal, Reports, Config Manager, Data Management, Deployment, Support Tools, and System Management. Below these, the breadcrumb path is 'Home > Alert Console'. The current view is 'Alert Console > Replication X'. The date is set to 'Jul 18, 2018'. A table lists replication events with columns for Timestamp, Store, Type, Severity, and Occurrences. One event is highlighted: Timestamp '7/19/18, 8:22 AM', Store '101', Type 'Xstore replication backlog', Severity 'Critical', and Occurrences '200'. Below this, a detailed view for 'Store 101 - Xstore replication backlog' is shown. It contains a table with columns 'Timestamp' and 'Workstation'. The timestamps range from 8:22:21 AM to 8:22:52 AM, and all workstation IDs are '1'. To the right of this table, additional details are provided: 'Timestamp Jul 19, 2018, 8:22:52 AM', 'Workstation ID 1', 'Operator ID 0', and 'Details PENDING REPLICATION RECORDS: 109'.

Timestamp	Store	Type	Severity	Occurrences
7/19/18, 8:22 AM	101	Xstore replication backlog	Critical	200

Timestamp	Workstation
8:22:52 AM	1
8:22:52 AM	1
8:22:52 AM	1
8:22:52 AM	1
8:22:42 AM	1
8:22:42 AM	1
8:22:42 AM	1
8:22:42 AM	1
8:22:42 AM	1
8:22:42 AM	1
8:22:32 AM	1
8:22:32 AM	1
8:22:32 AM	1
8:22:32 AM	1
8:22:21 AM	1

Timestamp Jul 19, 2018, 8:22:52 AM  
 Workstation ID 1  
 Operator ID 0  
 Details PENDING REPLICATION RECORDS: 109

## Replication Logged Events

- Xcenter persistence failure: A replication request was delivered to Xcenter but could not be persisted to the Xcenter DB. As a result, a record was written to the `rpl_replication_data` table. Information returned includes replication payload and meta data. (Xcenter)
- Xcenter replication crash: These errors are event Log error codes reported by the replication system. (Repl Crash)
- Xstore replication queue errors: An error failure occurred during replication. As a result, records are still in the register's replication queue. Information returned includes replication payload and meta data. (RepQ Process)
- Xstore replication backlog: There are more than "X" records in the replication queue that have not been tried, indicating a backlog or potential mis-configuration. Information returned includes replication payload and meta data. (RepQ Block)
- Xstore replication queue read errors: An error occurred when pulling data from the local replication queue. (RepQ Read)

## Connectivity

Click a logged event in the list to view additional details.

The logged events shown here are sourced from Xcenter's `ctl_event_log` table.

Figure 10-4 Connectivity Logged Events Detail

Journal Reports Config Manager Data Management Deployment Support Tools System Management

Home > Alert Console

Alert Console Connectivity ×

Date: Jul 18, 2018

Timestamp	Store	Type	Severity	Occurrences
7/19/18, 8:32 AM	101	Xstore database offline	Critical	10
7/19/18, 8:31 AM	101	Xpay auths offline	Critical	108
7/19/18, 7:41 AM	102	Xstore database offline	Medium	3

Store 101 - Xpay auths offline

Timestamp	Workstation
8:31:17 AM	1
8:31:17 AM	1
8:31:16 AM	1
8:31:14 AM	1
8:31:14 AM	1
8:31:13 AM	1
8:31:06 AM	1
8:31:06 AM	1
8:31:05 AM	1
8:30:50 AM	1
8:30:50 AM	1
8:30:49 AM	1
8:30:49 AM	1
8:30:44 AM	1

Timestamp Jul 19, 2018, 8:31:17 AM  
Workstation ID 1  
Operator ID 0  
Details CAUGHT EXCEPTION: dtv.tenderauth.OfflineException: no more hosts

## Connectivity Logged Events

- Data source offline: A ping failure or data access error occurred. As a result the data source will not be used. Information returned includes datasource name, scope (WAN/LAN), and cause. (DB Offline)
- Payment system offline: A payment systems host (Xpay) could not be reached. Information returned includes the message, stack trace, and destination IP/Host. (Xpay Offline)
- Order broker service offline: The order broker host (Oracle Retail Order Broker Cloud Service) could not be reached. Information returned includes the message, stack trace, and destination IP/Host. (Oracle Retail Order Broker Cloud Service Offline)
- Order broker service error: An error occurred during the order update process. Information returned includes message and stack trace. (Oracle Retail Order Broker Cloud Service Error)
- Service error: An error occurred while calling a web service. Information returned includes message, stack trace, and destination IP/Host. (Service Offline)
- Event log reporting error: An error occurred with the end-point Oracle Retail Xenvironment uses to report event log errors to Xcenter/Oracle Retail Xstore Office. (Evtlog Error)

### Note:

Oracle Retail Xenvironment uses this end-point to communicate any problems directly to Xcenter.

- Xstore register offline: A register (Xcenter client) has not sent a status update in "X" minutes. Information returned includes Store # and Reg #.

## About Xcenter Register Offline Alert Data

Xcenter register offline alert data is sourced from the `ctl_event_log` table as noted above, and also has a technical relationship to the `ctl_device_registration` table.

There is a process that runs in Oracle Retail Xstore Office which periodically observes the `ctl_device_registration` table. It notices when registers stop checking-in within certain configurable time limits. When the process notices a register has failed to check in, it adds a record to Xcenter's `ctl_event_log` (which then gets reported as an alert just like all the other alerts).

The process that observes `ctl_device_registration` can be configured as follows:

- Interval for Checking for Missing Registers - controls how frequently the process inspects `ctl_device_registration` for missing registers. Default is 15 (minutes).
- Time Before Register Is Considered Missing- how much time must elapse since a device last checked in before it is considered missing. Default is 61 (minutes).
- Time Before Missing Register Is Ignored - once a device has been missing for the amount of time specified here, it is no longer reported as a problem. Default is 72 (hours, aka 3 days).
- See also [System Management](#) for more information about Oracle Retail Xstore Office Configuration.

## Application

Click a logged event in the list to view additional details.

The logged events shown here are sourced from Xcenter's `ctl_event_log` table.



Figure 10-5 Application Logged Events Detail

The screenshot shows the Oracle Xadmin interface. At the top, there's a navigation bar with 'ORACLE Xadmin' and a user profile icon. Below that, a menu bar contains 'Journal', 'Reports', 'Config Manager', 'Data Management', 'Deployment', 'Support Tools', and 'System Management'. The breadcrumb trail is 'Home > Alert Console'. The main content area is titled 'Alert Console Application' and shows a table of events for the date 'Jul 18, 2018'. The table has columns for 'Timestamp', 'Store', 'Type', 'Severity', and 'Occurrences'. One event is listed: '7/19/18, 8:41 AM' for 'Store 101', 'Type: Xenvironment task error', 'Severity: Low', and 'Occurrences: 1'. Below the table, there's a section for 'Store 101 - Xenvironment task error' with a sub-table for 'Timestamp' and 'Workstation' showing '8:41:19 AM' and '1'. To the right of this sub-table, details are provided: 'Timestamp: Jul 19, 2018, 8:41:19 AM', 'Workstation ID: 1', 'Operator ID: 0', and 'Details: Source C:\xstorelog\relate does not exist, aborting.'

## Application Logged Events

- **Pre-flight error:** (Data, ciphers, SSL, and so on) A pre-flight error or errors occurred during application startup. All errors are included in this single message. Information returned includes pre-flight error names and descriptions. (Pre-Flight)
- **SSL expiration check:** An SSL certification used for communication with Xcenter or Xpayer other services is nearing, or has reached, its expiration date. Information returned includes a message. (SSL Cert)
- **Out of memory error:** The JVM ran out of memory, terminating the application. Information returned includes stack trace. (Crash)
- **Helpdesk error:** An unexpected error (helpdesk error) occurred. Information returned includes stack trace. (Helpdesk)
- **Legal Compliance Exceptions:** A number of errors related to country specific issues are notified here. For more details about legal compliance exceptions, see the *Oracle Retail Xstore Suite Country Accelerator User Guide* and the *Oracle Retail Xstore Suite Country Accelerator Technical Guide*.
- **Restart:** A mid-day restart was performed. (Restart)
- **Xenvironment Task:** Error message from Oracle Retail Xenvironment related to atoms and chains. (Xenv Task)
- **Xenvironment Database:** Error message from Oracle Retail Xenvironment related to database backups/restores. (Xenv DB)
- **Xenvironment IPC:** Error message from Oracle Retail Xenvironment for IPC errors with the IPC server. For example, when the SSL certificate is nearing expiration. (Xenv IPC)

## Hardware

Click a logged event in the list to view additional details.

The logged events shown here are sourced from Xcenter's `ctl_event_log` table

**Figure 10-6 Hardware Logged Events Details**

ORACLE Xadmin 1000

Journal Reports Config Manager Data Management Deployment Support Tools System Management

Home > Alert Console

Alert Console Hardware X

Date: Nov 15, 2018

Timestamp	Store	Type	Severity	Occurrences
11/15/18, 2:50 PM	570	Hardware device initialization error	Low	1
11/15/18, 2:49 PM	7	Hardware device initialization error	Low	1

Store 570 - Hardware device initialization error

Timestamp	Workstation
2:50:02 PM	55

Timestamp Nov 15, 2018, 2:50:02 PM  
Workstation ID 55  
Operator ID 0  
Details 55 WARN [] 2018-11-15 08:50:02.312 There was a problem claiming the fingerprint reader. (FAILURE) : Using default output context :: dtv.i18n.formatable.AbstractFormattable [qtp116203674-3501] There was a problem claiming the fingerprint reader. (FAILURE)  
Source dtv.pos.hardware.op.WaitForHardwareSetupOp.handleStartupMessages(WaitForHardwareSetupOp.java:106)

## Hardware Logged Events

- Hardware device initialization errors: A configured hardware device or devices could not be initialized. Information returned includes device names. (Initialization)
- Register disk space: The register's disk is nearing capacity and has less than 10% free. Information returned includes % free remaining. (Low Disk)
- JPOS hardware device error: A configured hardware device had a failure. (JPOS Error)

## Updates

Click a logged event in the list to view additional details.

The logged events shown here are sourced from Xcenter's `ctl_event_log` table.

Figure 10-7 Updates Logged Events Details

ORACLE Xadmin 1000

Journal Reports Config Manager Data Management Deployment Support Tools System Management

Home Alert Console

Alert Console Updates X

Date: Nov 8, 2018

Timestamp	Store	Type	Severity	Occurrences
11/8/18, 10:12 PM	0	DataLoader error	Low	1

Store 0 - DataLoader error

Timestamp	Workstation
10:12:03 PM	0

Timestamp Nov 8, 2018, 10:12:03 PM  
 Workstation ID 0  
 Operator ID 0  
 Details DataLoader processed data file\\fileuploads\org1000\Quick\_Items-badrow.mnt in 0 seconds with 3 persistables. Successful persistables: 2. Failed persistables: 1. success\_flag=false

## Updates Logged Events

- Update service offline: Cannot reach update service. Information returned includes stack trace. (Update Service)
- DataLoader error: A failure occurred while loading a download file. Information returned includes the message. (DataLoader)
- Config updates error: A failure occurred while applying updates. (Apply Update)
- Xenvironment update error: An error occurred related to Oracle Retail Xenvironment updates. (Xenv Update)

## Versioning

Click a logged event in the list to view additional details.

The logged events shown here are sourced from Xcenter's `ctl_event_log` table.

Figure 10-8 Versioning Logged Events Details

ORACLE Xadmin 1000

Journal Reports Config Manager Data Management Deployment Support Tools System Management

Home » Alert Console

Alert Console Versioning X

Date: Sep 17, 2018

Timestamp	Store	Type	Severity	Occurrences
9/17/18, 9:36 AM	761	Xenvironment version conflict	Medium	3

Store 761 - Xenvironment version conflict

Timestamp	Workstation
9:36:28 AM	1
9:21:28 AM	1
9:06:28 AM	1

Timestamp Sep 17, 2018, 9:36:28 AM  
 Workstation ID 1  
 Operator ID 0  
 Details \*\* XENV VERSION CONFLICT (env18.0.0.0.459 - ts00000) \*\* REG 1 :: env18.0.0.0.459 - ts00000 REG 60 :: env18.0.0.0.447 - ts00000

## Versioning Logged Events

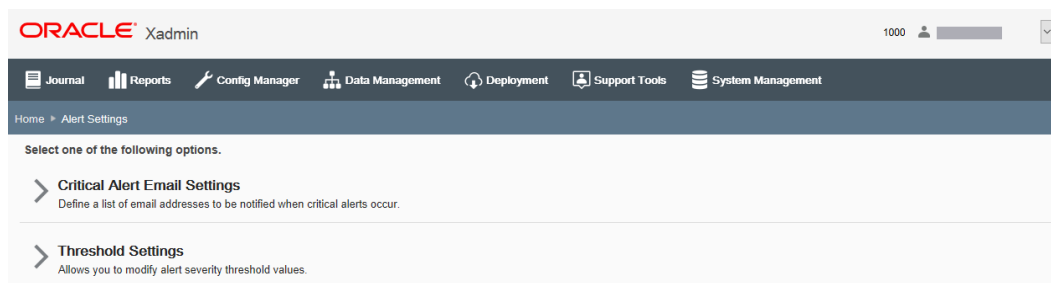
- In store version conflict for Xstore: A single retail location has multiple versions of the Oracle Retail Xstore Point-of-Service application running at the same time. Information returned includes versions by register. (Xstore Conflict)
- In store version conflict for Xenvironment: A single retail location has multiple versions of Oracle Retail Xenvironment running at the same time. Information returned includes versions by register. (Xenv Conflict)
- In store version conflict for Oracle Retail Xstore Office configs: A single retail location has multiple versions of configs running at the same time. Information returned includes versions by register. (Config Conflict)

## Alert Settings

The Alert Settings feature provides the ability to set up an email notification list to be used when critical alerts occur. Email recipients will receive an email that lists each active alert in which an event has occurred since the last email, without logging into Oracle Retail Xstore Office.

This feature also provides the ability to modify and customize the alert severity threshold level values for your organization. This provides the ability to set your organization's tolerance levels for the various alert events.

1. From the Oracle Retail Xstore Office menu, select **Support Tools** and then **Alert Settings**.
2. The Alert Settings page has two options, Critical Alert Email Settings and Threshold Settings

**Figure 10-9 Alert Settings Page**

- To set up recipients for critical alert emails, see [Critical Alert Email Settings](#) below.
- To set up alert threshold settings, see [Alert Threshold Settings](#).

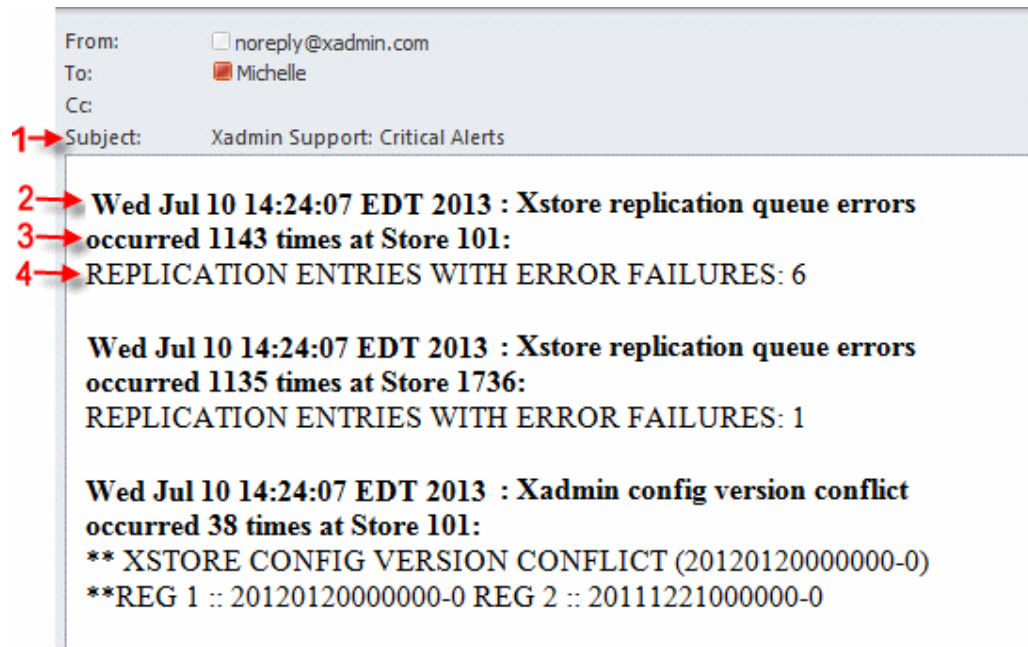
## Critical Alert Email Settings

Use this feature to define a list of email addresses to be notified when critical alerts occur. When set up, an email will automatically be sent to the specified recipients, without requiring logging in to Oracle Retail Xstore Office. The critical alert email will include all alerts that have gone critical since the previous polling interval. (The polling interval is once per minute).

### Note:

A unique alert (alertable event type/store) will be reported no more than one time in a single business day.

The email content includes the alert, alert type, store #, timestamp, and detail for the last critical alert. A critical alert email can contain one or more alerts.

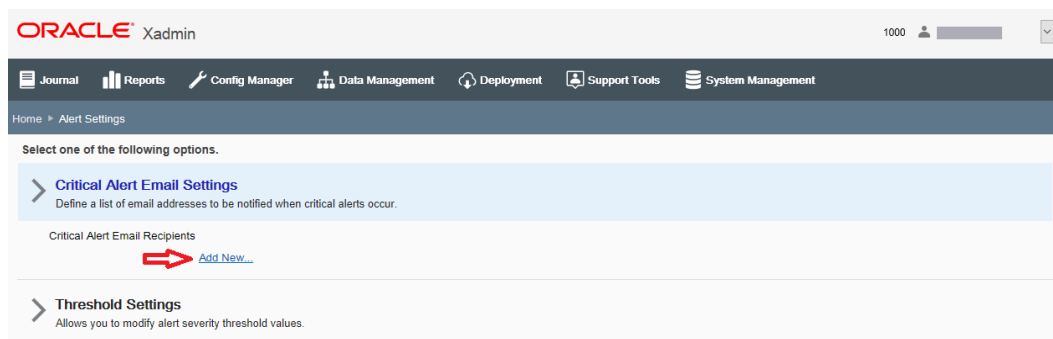
**Figure 10-10 Critical Alert Email Example**

1. Subject - Email subject line
2. Event Timestamp - Timestamp of when the precipitating event occurred  
Alert Name - Name of the alertable event type
3. Event Count - Number of events that have occurred  
Rtl Loc Id - Retail Location Id of the event
4. Event Details - A description of the event

## To Set Up Critical Alert Email Recipient Addresses

Perform the following steps to set up critical email alerts.

1. From the Oracle Retail Xstore Office menu, select **Support Tools - Alert Settings**.
2. At the Alert Settings page, click **Critical Alert Email Settings**.
3. Click the Add New link to define a new email address.

**Figure 10-11 Critical Alert Email - Add New Email Address**

4. When prompted, enter the recipient's email address and click **Save**.  
The email address is displayed on the screen and persisted to the database.

 **Note:**

To delete an email address, click the Delete link next to the email address you want to remove.

See [Alert Console](#) for more information about critical alerts.

## Alert Threshold Settings

Use the Thresholds Settings feature to manage system-wide alert threshold settings in your organization.

### To Define Alert Threshold Settings

Perform the following steps to define the threshold settings for alerts.

1. From the Oracle Retail Xstore Office menu, select **Support Tools - Alert Settings**.
2. At the Alert Settings page, click **Thresholds Settings**.

Figure 10-12 Alert Preferences Screen

The screenshot shows the Oracle Xadmin interface for Alert Settings. The page title is "Threshold Settings" and it includes a "Save" button. Below the title, there are two sections: "Replication" and "Connectivity". Each section has a table of alert types with columns for Medium, High, and Critical severity levels. The values in the tables are as follows:

Alert Type	Medium	High	Critical
Xcenter replication crash	3	5	10
Replication Queue Block	3	5	10
Xcenter	3	5	10
Replication Queue Read	3	120	170
Replication Queue Process	3	5	10

Alert Type	Medium	High	Critical
Xpay Offline	3	5	10
Register Offline	3	5	10
Locate Offline	3	5	10
SAF Queue Not Empty	3	5	10
Database Offline	3	5	10
Service Offline	3	5	10

- The alert preferences screen shows all alert types and their current thresholds. Edit the values as needed and click **Save**.

## About Alert Severity Threshold Levels

- Alert type severity threshold levels include Medium, High, and Critical options. See [Alert Console](#) for more information about the alert types.

### Note:

There is no column for LOW threshold because Low is always considered to be 0. If there is even one alertable event, the severity must at least be considered Low.

- When setting the alert severity threshold values, the relative magnitude values between alert levels must be respected, (that is Critical level cannot be lower than High level).
- To see the alert type description, use the mouse to hover over the alert type label.
- When an alert type value is changed, a web service call sends the alert value to the `cfg_alert_severity_threshold` table.
- Changes to a critical alert threshold are not retroactive.

For example, consider the scenario where there have been 10 "register offline" events, and the critical alert threshold for "register offline" is 20. If the critical alert threshold is changed to 5, a critical alert email will not be sent until the next "register offline" event occurs (#11). So in this scenario, when the 11th "register offline" event occurs, a critical email will be sent.



- A system-wide configuration parameter defines the start of a business day in hours past GMT 00:00. See [System Management](#), [Oracle Retail Xstore Office Configuration Options](#) for more information about this configuration option.

## Support Settings: Technical Information

This section deals with support settings.

### xcenter.properties

**Table 10-1 Xcenter Properties Information**

Setting	Valid Values	Description
dtv.xadmin.smtp.host	String	The email host name.
dtv.xadmin.smtp.port	Integer	The email port name.
dtv.xadmin.smtp.auth	Boolean	If true, Oracle Retail Xstore Point of Service will make secure SMTP connections (smtps) for email operations. This usually requires a user name and password (DefaultMailUser & DefaultMailPassword). If false, Oracle Retail Xstore Point of Service will use unsecured SMTP connections (smtp) for email operations, and username and password will be ignored.
dtv.xadmin.smtp.user	String	Username to use if making secure SMTP connections.
dtv.xadmin.smtp.password	String	Password to use if making secure SMTP connections.
dtv.xadmin.smtp.sender	String	The email sender.
dtv.xadmin.support.criticalAlertEmails.enabled	Boolean	True or false.

### cfg\_critical\_alert\_email Table

**Table 10-2 cfg\_critical\_alert\_email Table**

Column	Valid Values	Description
cfg_critical_alert_email.organization_id	Integer	Organization ID
cfg_critical_alert_email.email_address	Varchar(60)	Critical alert email address
cfg_critical_alert_email.create_date	Datetime	Create date
cfg_critical_alert_email.create_user_id	Varchar(30)	Create User ID
cfg_critical_alert_email.update_date	Datetime	Update date
cfg_critical_alert_email.update_user_id	Varchar(30)	Update user ID

## ctl\_event\_logTable

**Table 10-3** ctl\_event\_logTable

Column	Valid Values	Description
ctl_event_log.arrival_timestamp	Datetime	The arrival time of the event log database record into Xcenter.

## cfg\_alert\_serverity\_threshold Table

See the *Oracle Retail Xstore Office Database Dictionary Guide* for more information.

## Deployed Oracle Retail Xstore Point-of-Service Versions

The Deployed Xstore Versions feature shows Oracle Retail Xstore Point of Service version information by store in a pie chart format. The store's primary register is responsible for reporting the version of the store to Oracle Retail Xstore Office (`ctl_device_registration.primary_register_flag = True`). The size of each section of the chart is proportional to the corresponding number of stores running the Oracle Retail Xstore Point-of-Service version.

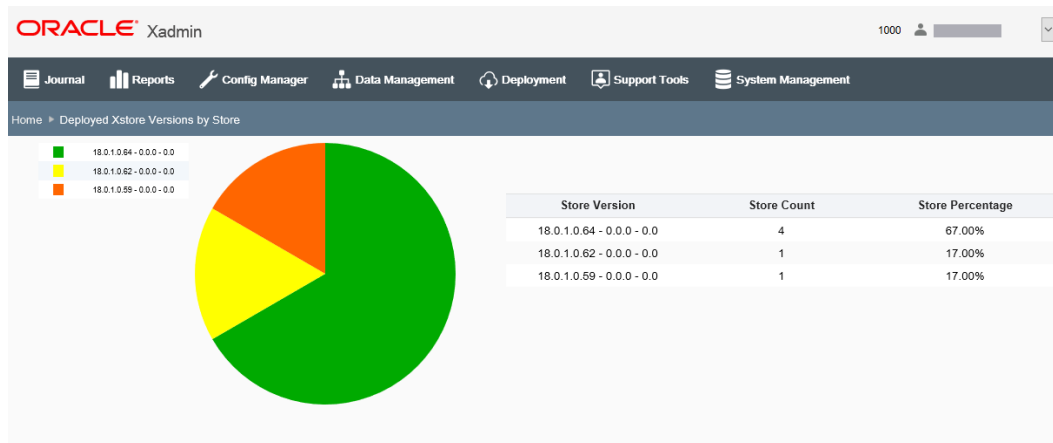
 **Note:**

Due to rounding, the totals shown on the Version Information charts may not add up to 100%.

You must have the Deployed Xstore Versions privilege to use this feature.

1. From the Oracle Retail Xstore Office menu, select **Support Tools - Deployed Xstore Versions**, or click the Deployed Xstore Versions link in the Support Tools panel.
2. The Deployed Xstore Versions by Store page displays.

**Figure 10-13** Deployed Oracle Retail Xstore Point of Service Versions by Store Page



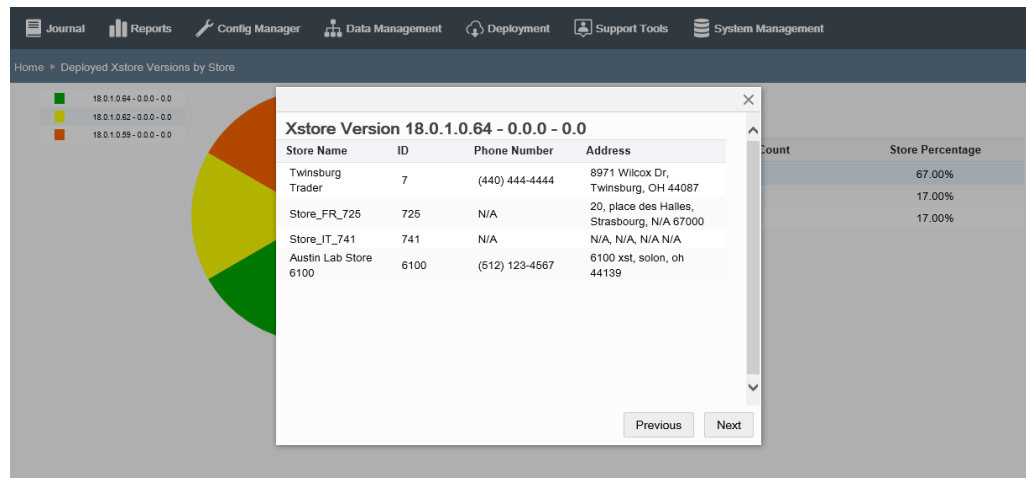
This chart shows the Oracle Retail Xstore Point-of-Service versions currently running in the stores in your organization.

- Each Oracle Retail Xstore Point-of-Service version is shown as a color-coded section of the chart.
- The key to the right of the chart indicates the Oracle Retail Xstore Point-of-Service versions included on the chart, and which color represents each version.
- The percentage of stores in your organization running each version of Oracle Retail Xstore Point of Service is shown below the version number.
- The most-recent Oracle Retail Xstore Point-of-Service version is shown in the green section of chart, located on the right side of the chart. (Version 7.0.0.296 -0.0.0 - 0.0 in this example).
- Using the mouse, hover over a section of the chart to display the Oracle Retail Xstore Point-of-Service version and percentage of stores running the version compared to all stores.
- To view additional detail, select a section of the chart and click on it. See [Oracle Retail Xstore Point-of-Service Version by Store Detail](#) below.

## Oracle Retail Xstore Point-of-Service Version by Store Detail

The detailed information available by clicking on a section of the chart shows the Store Name, Retail Location ID, Phone Number, and Address.

**Figure 10-14 Oracle Retail Xstore Point-of-Service Version by Store Detail**



- Use the Up and Down arrows to view detail about the chart section above and below the currently selected section.
- To close the Detail window, click the **Close** button.
- If needed, a scroll bar is provided on the right side of the window.

## PosLog Publisher

The PosLog Publisher feature provides the ability to compile the PosLog data from within Oracle Retail Xstore Office and save it as a file to a specified location. This allows you to manage this information centrally, without having to connect remotely to stores. Xcenter data can be generated for an org node, store, or only specific registers within a store, for a specific date range.

1. From the Oracle Retail Xstore Office menu, select **Support Tools - Publish PosLog Data**, or click the Publish PosLog Data link in the Support Tools panel.
2. At the PosLog Search page, enter search criteria to find the PosLog data, then click **Search**.

**Figure 10-15 PosLog Search Page**

ORACLE Xadmin 1000

Journal Reports Config Manager Data Management Deployment Support Tools System Management

Home > POSLog Search

Search for POSLogs that you would like to publish.

Org Node

Trans #

Register #

Business Date: 2018-07-19 To 2018-07-19

Search

- Org Node - The org node, selected from the drop-down list. [REQUIRED]
- Trans # - The transaction identifier.

- Register # -The register identifier.
  - Business Date range - The transaction date range. [REQUIRED]
3. The Search Results page displays the summary results of the search. The maximum number of results returned by the search is controlled by configuration.

See also POSLog Publish Max Search Results and Number of Records in POSLog Publisher Result Page configuration options in [System Management](#) for more information about these configuration settings.

The PosLog Publisher Search Results page layout will vary depending on the Oracle Retail Xstore Office configuration setup for PosLog Publisher. See [PosLog Publisher Search Results Page Layout Examples](#) for additional information about the search results page options.

**Figure 10-16 Search Results Page - Summary View**

ORACLE Xadmin 1000

Journal Reports Config Manager Data Management Deployment Support Tools System Management

Home > POSLog Search > Search Results

Org Node CORP:\*  
Date Sep 13, 2018 To Sep 17, 2018  
Trans Count 293

View More POSLogs: Store 7, Reg 1, Trans 4471 (Sep 12, 2018)

Publish All Publish

Trans #	Type	Register #	Store #	Date	
4476	Inventory Control	1	7	Sep 12, 2018	<input checked="" type="checkbox"/>
4477	Order	1	7	Sep 12, 2018	<input checked="" type="checkbox"/>
4478	Tender Control	1	7	Sep 12, 2018	<input checked="" type="checkbox"/>
4479	Workstation Close	1	7	Sep 12, 2018	<input checked="" type="checkbox"/>
4480	Tender Control	1	7	Sep 12, 2018	<input checked="" type="checkbox"/>
4481	System Close	1	7	Sep 12, 2018	<input checked="" type="checkbox"/>
4482	System Open	1	7	Sep 13, 2018	<input checked="" type="checkbox"/>

- If no transactions match your search criteria, Trans Count will show No results found.

**Figure 10-17 POSLog Search - No Results**

Journal Reports Config Manager Data Management Deployment Support Tools System Management

Home > POSLog Search > Search Results

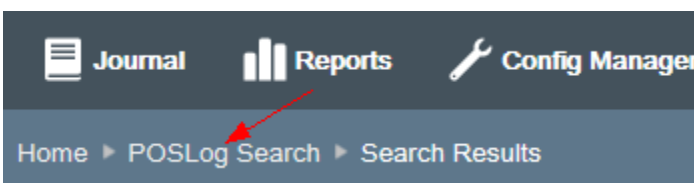
Org Node CORP:\*  
Date Jun 5, 2018 To Jul 26, 2018  
Trans Count: No results found.

Publish All Publish

Trans #	Type	Register #	Store #	Date	
No results found.					

- Click PosLog Search in the navigation breadcrumb to return to the PosLog Search page.

**Figure 10-18 POSLog Breadcrumb**

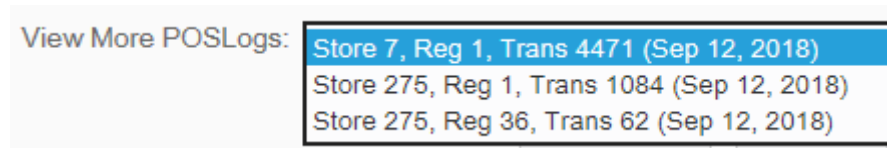


By default, all transactions returned in the search are selected as indicated by the check mark in the right-most column.

You have the following options available to indicate which PosLogs are to be published:

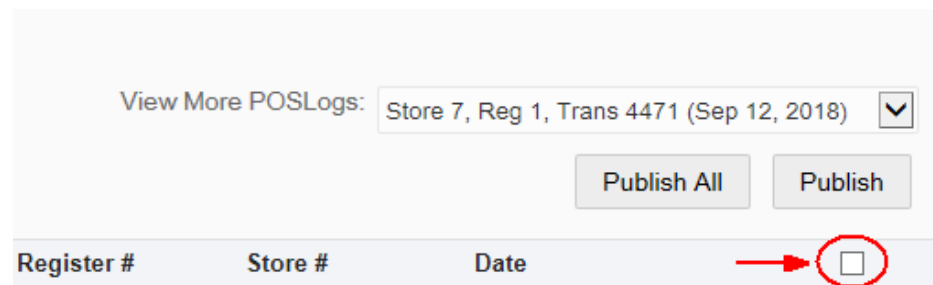
- If applicable, select the group from the View More POSLogs drop-down list to view more PosLogs.

**Figure 10-19 View More POSLogs - Dropdown List**

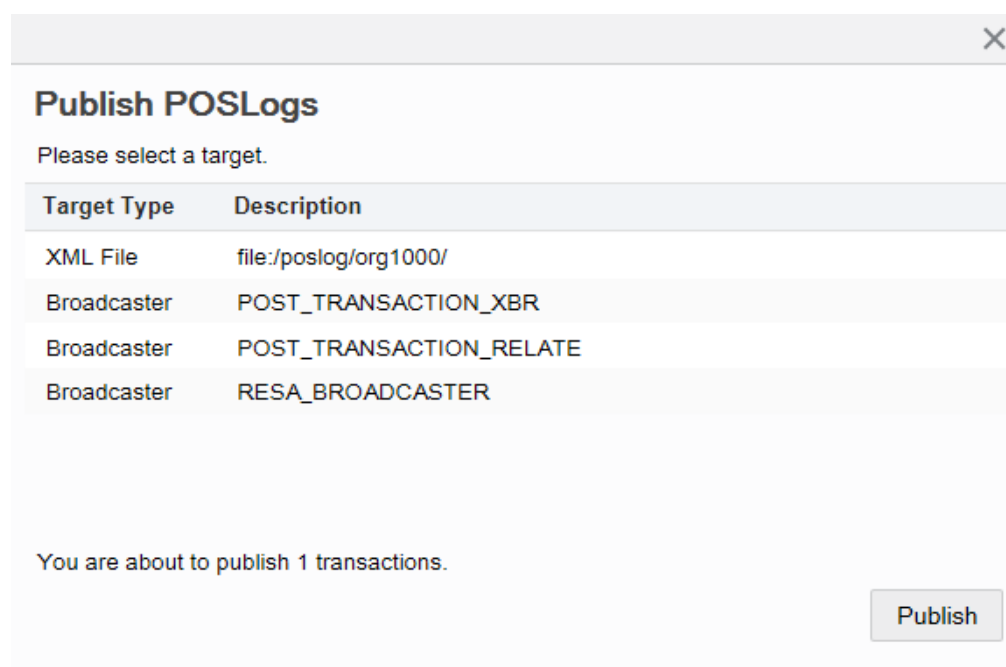


- To select a small sub-set of transactions, un-check the header check box to remove the check marks, then select each transaction on this page to be published.

**Figure 10-20 Header Check Box - Unchecked**



- If you want to publish most of the transactions on the page, selectively un-check the transactions you do not want to publish.
4. Actions on this page include Publish and Publish All:
    - Click **Publish All** to publish all transactions returned by the search, up to the maximum search results limit. This option overrides any selective changes you may have made to the check marks in the right-most column.
    - Click **Publish** to publish the transaction or transactions you selected on the page.
  5. When prompted, select the target from the list of targets available for publishing and rebroadcasting:
    - At the Publish POSLogs prompt, select how you want to export the POSLogs.

**Figure 10-21 Publish PosLogs Target Prompt**

- Publish the PosLog data from within Oracle Retail Xstore Office and save it as an XML file to the specified directory configured in Published POSLog Directory. See [System Management, Oracle Retail Xstore Office Configuration Options](#) for more information about specifying the directory where the published PosLog file will be saved.

<OR>

- Publish the PosLog data to the Broadcaster system in Xcenter through Web services.

 **Note:**

Click the Close icon if you do not want to publish the selected PosLog. You will be returned to the Search Results page.

- Click **Publish**.
- At the confirmation prompt, click **OK** to close the window.

## PosLog Publisher Search Results Page Layout Examples

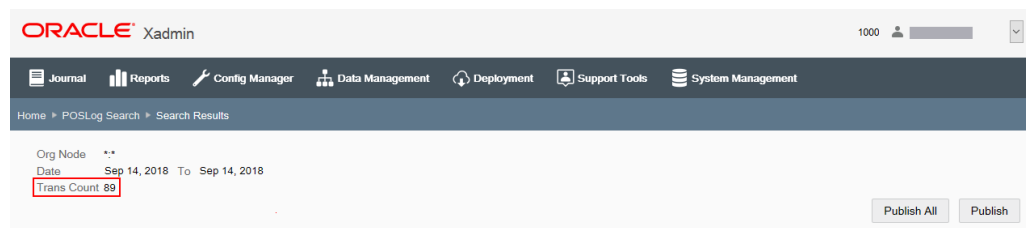
The PosLog Publisher Search Results Page page layout will vary depending on the Oracle Retail Xstore Office configuration setup for PosLog Publisher. The following examples show the different page layouts based on the following configuration settings:

- Number of Records in POSLog Publisher Result Page = 100
- POSLog Publish Max Search Results =5000

## Example 1: Trans Count < 100, Search Results < 5000

You will see these results since the transaction count of 89 is less than 100. In this example, both the number of records shown per page (up to 100) and the maximum search results limit (up to 5000) have not been reached.

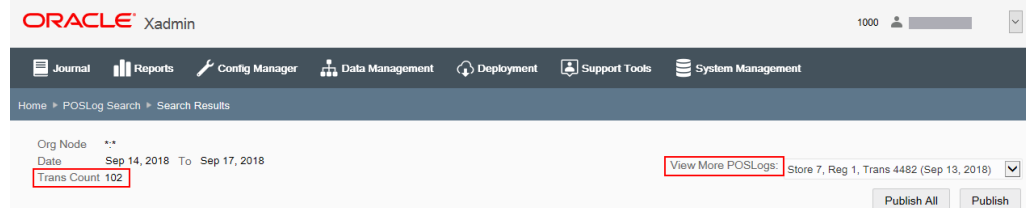
**Figure 10-22 Example 1 - Trans Count < 100, Search Results < 5000**



## Example 2: Trans Count > 100, Search Results < 5000

In this scenario you will have the option to View More Poslogs since the transaction count exceeds the limit of 100 records shown per page, but is less than the maximum search results limit of 5000.

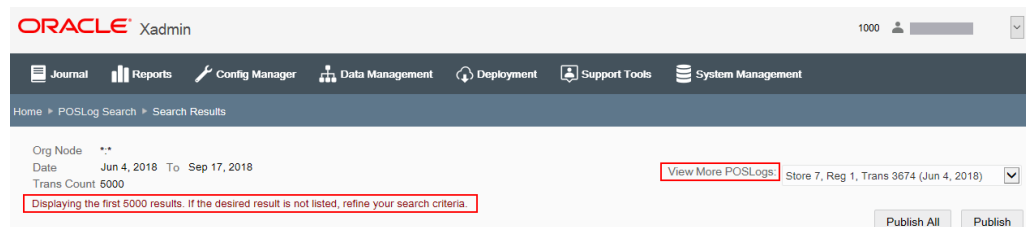
**Figure 10-23 Example 2 -Trans Count > 100, Search Results < 5000**



## Example 3: Trans Count > 100, Search Results > 5000

In this scenario you will have the option to View More Poslogs since the transaction count exceeds the limit of 100 records shown per page. Also, a message displays indicating the maximum search results limit of 5000 has been exceeded. If the desired result is not listed in the View More PosLogs drop-down list, you must refine your search criteria and search again.

**Figure 10-24 Example 3 - Trans Count > 100, Search Results > 5000**





# Temporary Store Server Management

The Temporary Store Server Management page allows you to view, approve or reject mobile server requests for temporary stores. There are two types of temporary stores.

- **Event Store**  
An event store has a separate store number from all brick-and-mortar locations.
- **Extension Store**  
An extension store shares a store number with a specific brick-and-mortar location.

You can also create new event or extension temporary store requests, or cancel a server by using this function.

1. From the Oracle Retail Xstore Office menu, select Support Tools - Temporary Store Server Management, or click the Temporary Store Server Management link in the Support Tools panel.
2. At the Temporary Store Request page you can view, approve/reject requests, cancel a server or create new event or extension temporary store requests.

All available temporary store mobile servers are displayed. When a server is setup and Xstore Mobile is installed, Xcenter receives the server information.

**Figure 10-25 Temporary Store Request**

Request Type	Description	Request Status	Store	Event Start Date	Event End Date	Assigned Server
Extension		Approved	101	2020-09-23	2020-09-30	
Event		Approved	102	2020-09-08		
Event		Cancelled	103	2020-09-24		
Event		Approved	301	2020-09-08	2020-09-22	
Extension		Cancelled	2020	2020-09-01		
Event		Approved	2020	2020-09-04		
Extension		Approved	2020	2020-09-11	2020-09-14	
Extension		Approved	2020	2020-09-16		
Extension		Approved	2020	2020-09-23		
Extension		Approved	2020	2020-09-08	2020-09-12	
Extension		Approved	2020	2020-09-08		
Extension		Approved	2020	2020-09-08		
Extension		Submitted	2020	2020-08-27	2020-08-30	
Extension		Approved	2020	2020-08-08		
Extension		Cancelled	2020	2010-10-01	2028-10-01	
Extension		Rejected	2020	2019-09-01		
Extension		Submitted	2020	2020-01-01	2022-01-03	
Extension		Approved	2020	2020-09-11	2020-09-18	
Extension		Submitted	2020	2020-09-01		

## Adding a Request

To add temporary store requests:

1. Select **Add New**. The Temporary Store Request window is displayed.
2. Enter/select the following fields:
  - Request Type  
Select the request type event or extension from the list.
  - Description  
Enter a description for the request.
  - Store  
Enter or search for a store number.
  - Event Start Date  
Enter a start date for the event.
  - Sever Active Date  
Enter the active date for the server. This field is optional. Connections to the temporary store will be restricted to the start date unless a server active date is set here.
  - Event End Date  
Enter a start date for the event.
  - Is the temporary store in the same tax location? checkbox  
If checked, the temporary store will use the same tax location as the brick-and-mortar tax location.  
If unchecked, you will be prompted for a tax location for the temporary store during the register open process.

 **Note:**

The checkbox is only available for the request type extension.

- Available Servers  
Select a server from the list.
- Is the server not in this list? checkbox  
If you select this checkbox, the following fields are displayed:
- Server Hostname  
Enter the hostname of the new server.
  - Server Port  
Enter the port of the new server.
  - Register Range Start
  - Register Range End
- Comments  
Enter comments for the request, if necessary.

3. Click **Save** to store the temporary store request. The request is displayed on the Temporary Store Request page. The status of the request is submitted. The request can now be approved or rejected. For more information about how to approve or reject a request, see the [Approving/Rejecting a Request or Assigning a Server](#) section.

## Approving/Rejecting a Request or Assigning a Server

To approve/reject a request or assign different server:

1. Select a request in the table. The Temporary Store Request window is displayed.
  - Select **Approve** to approve the current request. A message is displayed. Confirm with **OK**. The request is displayed on the Temporary Store Request page with the status **Approved**.
  - Select **Reject** to reject the current request. A message is displayed. Select **Yes** to continue. The request is displayed on the Temporary Store Request page with the status **Rejected**.
  - To assign a different server, select the **Is the server not in this list?** checkbox.

The following fields are displayed:

- **Server Hostname**  
Enter the hostname of the new server.
- **Server Port**  
Enter the port of the new server.
- **Register Range Start**
- **Register Range End**
- **Select Approve**. The approved request with the new server is shown in the table.

### **Note:**

When an Xadmin user approves, or rejects an extension store request, a store message is generated and displayed in the target store along with the event request update.

## Cancelling a Server Request

Once a server is assigned to the temporary store request, you can cancel the request. To cancel a server request:

1. Select a request in the table. The Temporary Store Request window is displayed.
2. Then click **Cancel Request**. The selected server is removed from the store. You can add comments for cancelling the request. The comments are communicated to the store and a notification is created in Xstore.

 **Note:**

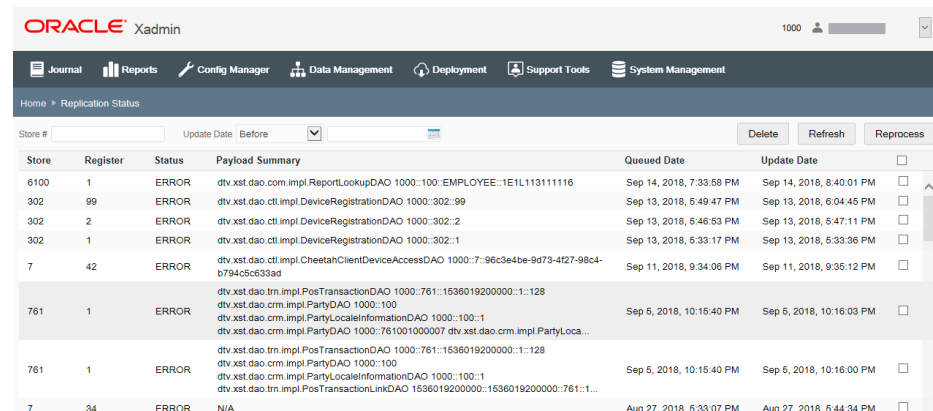
The server will also be removed from the store, when the date range expired.

## Replication Status

The Replication Status page shows ERROR status information related to the `rpl_replication_data` table.

1. From the Oracle Retail Xstore Office menu, select Support Tools - Replication Status, or click the Replication Status link in the Support Tools panel.
2. At the Replication Status page, the first 500 results are displayed automatically:
  - If the desired result is not listed, go to step 3 below to refine your search criteria.
  - If the desired result is listed, skip to step 5 below.


**Figure 10-26 Replication Status Page**



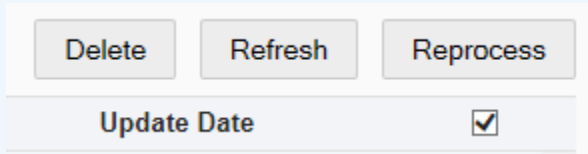
Store	Register	Status	Payload Summary	Queued Date	Update Date
6100	1	ERROR	dtv.xst.dao.com.impl.ReportLookupDAO 1000:100:EMPLOYEE:1E1L113111116	Sep 14, 2018, 7:33:58 PM	Sep 14, 2018, 8:40:01 PM
302	99	ERROR	dtv.xst.dao.cti.impl.DeviceRegistrationDAO 1000:302:99	Sep 13, 2018, 5:49:47 PM	Sep 13, 2018, 6:04:45 PM
302	2	ERROR	dtv.xst.dao.cti.impl.DeviceRegistrationDAO 1000:302:2	Sep 13, 2018, 5:46:53 PM	Sep 13, 2018, 6:47:11 PM
302	1	ERROR	dtv.xst.dao.cti.impl.DeviceRegistrationDAO 1000:302:1	Sep 13, 2018, 5:33:17 PM	Sep 13, 2018, 6:33:36 PM
7	42	ERROR	dtv.xst.dao.cti.impl.CheetahClientDeviceAccessDAO 1000:7:96c3e4be-9d73-4f27-98cd-b794c5c633ad	Sep 11, 2018, 9:34:06 PM	Sep 11, 2018, 9:35:12 PM
761	1	ERROR	dtv.xst.dao.trn.impl.PosTransactionDAO 1000:761:1536019200000:1:128 dtv.xst.dao.crm.impl.PartyDAO 1000:100 dtv.xst.dao.crm.impl.PartyLocaleInformationDAO 1000:100:1 dtv.xst.dao.crm.impl.PartyDAO 1000:761001000007 dtv.xst.dao.crm.impl.PartyLoca...	Sep 5, 2018, 10:15:40 PM	Sep 5, 2018, 10:16:03 PM
761	1	ERROR	dtv.xst.dao.trn.impl.PosTransactionDAO 1000:761:1536019200000:1:128 dtv.xst.dao.crm.impl.PartyDAO 1000:100 dtv.xst.dao.crm.impl.PartyLocaleInformationDAO 1000:100:1 dtv.xst.dao.trn.impl.PosTransactionLinkDAO 1536019200000:761:1...	Sep 5, 2018, 10:15:40 PM	Sep 5, 2018, 10:16:00 PM
7	34	ERROR	N/A	Aug 27, 2018, 5:33:07 PM	Aug 27, 2018, 5:44:34 PM

3. To search for replication failures based store IDs and/or last update date, complete the following fields as needed:
  - **Store #** - Enter/select the store number.  
If specified, the application only accepts valid store number inputs. A validation error will display if the specified store number is invalid.
  - **Update Date** - From the drop-down list, select Before, After, or Equal to, then select or enter a date.  
The update date criterion will be ignored if the input is not valid. Future dates are considered invalid.
4. Click **Refresh**.  
The records in the data table are sorted by update date (the last modified date) by default. To reorder the list, click on a column header.
5. With a record displayed you have the following options:

- **Delete** - Select the check box associated with the record (or records) and click the **Delete** button to delete the selected replication error. When prompted, click **Yes** to confirm you want to delete the record. Click **OK** to close the confirmation box.
- **Reprocess** - Select the check box associated with the record (or records) and click the **Reprocess** button to reprocess the replication error record(s). When prompted, click **Yes** to confirm you want to reprocess the record(s). Click **OK** to close the confirmation box.

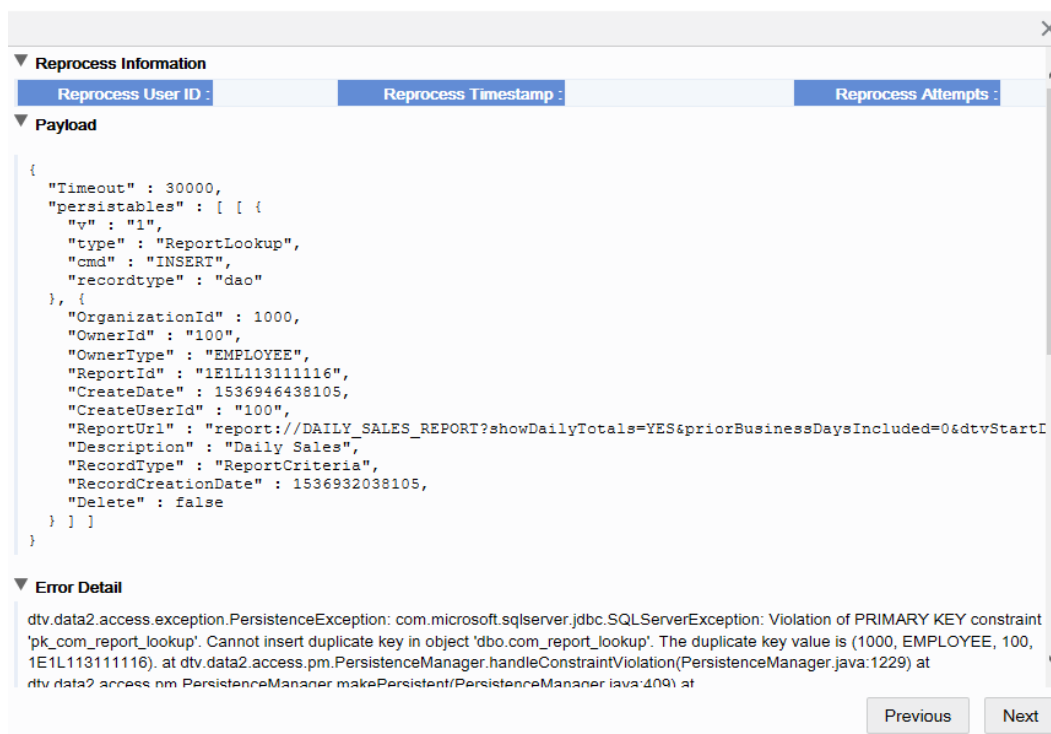
 **Note:**

To select all records at once, click the check box in the table header.



- **View** - Click a record to view the detail information about the selected record.

**Figure 10-27 Record Detail Window**



**Reprocess Information**

Reprocess User ID	Reprocess Timestamp	Reprocess Attempts

**Payload**

```
{
  "Timeout" : 30000,
  "persistables" : [ [ {
    "v" : "1",
    "type" : "ReportLookup",
    "cmd" : "INSERT",
    "recordtype" : "dao"
  }, {
    "OrganizationId" : 1000,
    "OwnerId" : "100",
    "OwnerType" : "EMPLOYEE",
    "ReportId" : "1E1L113111116",
    "CreateDate" : 1536946438105,
    "CreateUserId" : "100",
    "ReportUrl" : "report://DAILY_SALES_REPORT?showDailyTotals=YES&priorBusinessDaysIncluded=0&dtvStartI",
    "Description" : "Daily Sales",
    "RecordType" : "ReportCriteria",
    "RecordCreationDate" : 1536932038105,
    "Delete" : false
  } ] ]
}
```

**Error Detail**

dtv.data2.access.exception.PersistenceException: com.microsoft.sqlserver.jdbc.SqlServerException: Violation of PRIMARY KEY constraint 'pk\_com\_report\_lookup'. Cannot insert duplicate key in object 'dbo.com\_report\_lookup'. The duplicate key value is (1000, EMPLOYEE, 100, 1E1L113111116), at dtv.data2.access.pm.PersistenceManager.handleConstraintViolation(PersistenceManager.java:1229) at dtv.data2.access.nm.PersistenceManager.makePersistent(PersistenceManager.java:409) at

Previous Next

The following information is shown in the Record Detail window:

- **Reprocess Information** - (Populated when applicable) This section shows the ID of the user who reprocessed the record, the last reprocess date and time, and the total number of reprocess attempts.
- **Payload** - This section shows the entire contents of the replication data sent by an Oracle Retail Xstore Point-of-Service register.
- **Error Detail** - This section shows the technical details (like a java stack trace) of the error.

 **Note:**

See the *Oracle Retail Xstore Suite Implementation and Security Guide* for more information about replication.

# A

## Appendix: About Deployments

This chapter explains how deployments are created and tracked by Oracle Retail Xstore Office and applied by Oracle Retail Xstore Point of Service and Oracle Retail Xenvironment. To allow corporate users to easily maintain store systems, Oracle Retail Xstore Office provides the ability to deploy changes directly to retail locations or sets of retail locations. A deployment consists of a file, or set of files, and information dictating how and when it will be processed. Deployments may include Dataloader download files, configuration jar files, debit bin files, encryption cipher files, or update jar files. See [Glossary](#) for additional details about these types of files. In this appendix, the file, or files, that will be deployed are referred to as deployment files. In addition to these deployment files, a deployment includes information that allows for precise distribution to the desired target group. This information includes the locations within the hierarchy that will receive the deployment, the date upon which they will be notified of its availability, when they should begin to download it, and when they should apply it

### Application Roles

This section describes application roles.

### Oracle Retail Xstore Office

Oracle Retail Xstore Office provides an interface for creating deployments. The Configuration Manager and Data Management features are used to create configuration and data changes, and can also be used to upload files of supported types to be included in deployments. Functionality for automatically creating deployments for files that are placed in a location on the file system using header information to determine the target group and target application date is also provided.

Whenever a deployment is created, Oracle Retail Xstore Office is responsible for saving the deployment details in the form of a manifest and uploading any deployment files to the Apache file server. Once a deployment is created, its status can be monitored in real-time using Oracle Retail Xstore Office's Deployment Viewer feature.

### Xcenter (a part of Oracle Retail Xstore Office)

Xcenter assumes two critical roles in the deployment process: responsibility for communicating deployments to stores, and responsibility for accepting status-related feedback pertaining to those deployments.

When a store queries for any available deployments, Xcenter assembles a package that includes deployment manifests for deployments that haven't yet been acknowledged as having been received, and connectivity details for the Apache server that is hosting the files related to those deployments.

It also receives and stores status feedback from the store systems when the manifest for a deployment has been received successfully, when a deployment has been downloaded, and when a deployment has been applied.

## Oracle Retail Xstore Point of Service

The downloaded deployments from Oracle Retail Xenvironment are applied to Oracle Retail Xstore Point of Service.

## Oracle Retail Xenvironment

Oracle Retail Xenvironment is responsible for querying Xcenter for new deployments and then downloading and applying deployments. It is responsible for forwarding the details of the deployment to the Oracle Retail Xenvironment lead, retaining the details pertaining to it, downloading any necessary deployment files, and properly applying those files. It also reports the status of each of those steps back to Xcenter so that the status of each deployment can be tracked in real-time from Oracle Retail Xstore Office.

## Apache (httpd)

Apache is an HTTP server that hosts deployed files so they can be retrieved for application on store systems. When a deployment is initiated from Oracle Retail Xstore Office, files are uploaded to it and stored for later retrieval by Oracle Retail Xenvironment.

## DataLoader

DataLoader is responsible for applying any Configuration Manager changes that impact the database, and any other DataLoader download files that have been deployed to stores. It translates data changes from delimited text to database table data.



### Note:

When you make changes in Data Manager and deploy them, they automatically update the Xcenter database. There is no DataLoader file created and no DataLoader processing necessary. The Xcenter database is updated directly. If anything fails, it can be found in the Xcenter or Oracle Retail Xstore Office log file.

## Overview: How Files Are Managed

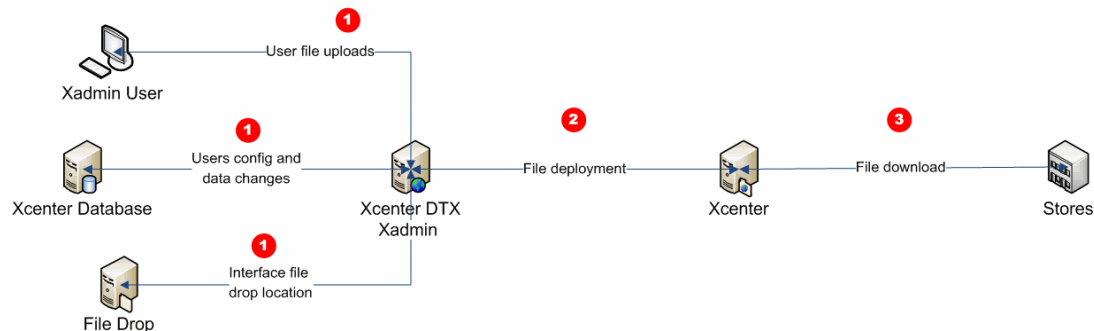
Oracle Retail Xstore Office's file management capabilities can be used to transfer files to and from the store and corporate environments. Xcenter file management transfers only files required by the Oracle Retail Xstore Suite.

The file management capabilities in Xcenter leverage the Apache Web Server for file downloading and posting.



## File Download to Stores

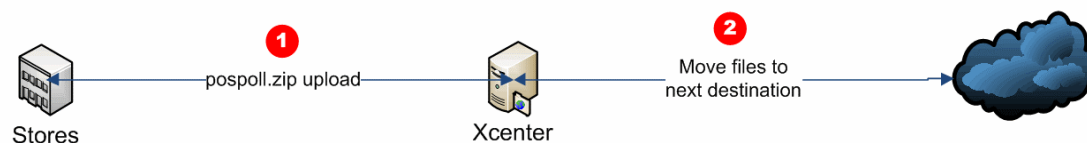
**Figure A-1 File Download to Stores**



- Multiple incoming channels are used to target file deliveries to stores: file uploads and configuration changes made through the Oracle Retail Xstore Office UI and files dropped by external systems.
- Oracle Retail Xenvironment retrieves deployments during closing and on a scheduled interval throughout the day. A back office menu option within Oracle Retail Xstore Point of Service can also be used to check for updates.
- Feedback on deployments is published to Xcenter and can be reviewed in Oracle Retail Xstore Office.

## File Upload from Stores

**Figure A-2 File Upload from Stores**



- Oracle Retail Xenvironment collects logs from in-store systems (pospoll.zip) and uploads to Xcenter.
- The files are left in a configurable directory location.
- A customer-specific script can be written to retrieve files from Xcenter in order to move files to their next destination. That process is not provided as part of the Oracle Retail Xstore Suite.

## Overview: About The Deployment Manifest

The deployment manifest is an XML-encoded representation of the deployment file and contains instructions Oracle Retail Xenvironment uses for handling the deployment files. The

manifest contains no configuration information itself, and is simply a set of instructions to be used by Oracle Retail Xenvironment.

## Sample Deployment Manifest

```
<?xml version="1.0" encoding="UTF-8"?>
<deploymentManifest xmlns:xsi="http://www.w3.org/2001/XMLSchema-instance"
xsi:noNamespaceSchemaLocation="DeploymentManifest.xsd">
<deployment-id>12345</deployment-id>
<deployment-manifest-version>1</deployment-manifest-version>
<updates>
<update>
<relative-url>/path-to-file</relative-url>
<type>APPUPD</type>
<download-priority>IMMEDIATE</download-priority>
<apply-priority>STORE_CLOSE</apply-priority>
<file-hash>asdadasdasd</file-hash>
</update>
<update>
<relative-url>/path2</relative-url>
<type>DEBITBIN</type>
<download-priority>IMMEDIATE</download-priority>
<apply-priority>IMMEDIATE</apply-priority>
<file-hash>hashhashhash</file-hash>
</update>
</updates>
</deploymentManifest>
```

`deployment-id` - The numeric deployment ID from Xcenter. May be included twice:

- Once on the manifest (generated by Oracle Retail Xstore Office)
- And once - [OPTIONAL] - on each update

`deployment-manifest-version` - The version of the deployment manifest.

`updates`

- `relative-url` - The relative path to download the update from. The path is relative to the URL specified in configuration.
- `type` - Enumeration values include: CONFIG, APPUPD, DATA, COMPRESSED\_DATA, CIP, and DEBITBIN.
- `download-priority` - STORE\_CLOSE = Download during the close, IMMEDIATE = Download immediately.
- `apply-priority` - STORE\_CLOSE = Wait until the store close to apply, IMMEDIATE = apply immediately
- `file-hash` - The MD5 hash of the file being downloaded.
- If Oracle Retail Xenvironment receives configs/manifests on a nonlead, they will be forwarded to the lead.
- If Oracle Retail Xenvironment receives a manifest during the close.
- Oracle Retail Xenvironment will not attempt to process IMMEDIATE deployments while a close is in progress. They will be processed after the close has completed.
- The manifest data will be saved to disk.

- The IMMEDIATE deployments will be processed sometime after the close has completed.
- The STORE\_CLOSE deployments will be processed during that close if the manifest is sent before that point in the close, otherwise they will wait until the next close.
- A RSS feed named immediate is used for the immediate deployments.

## Examples: Deployment Scenarios

This section describes different deployment scenarios.

### Deploying an Uploaded File

1. A file of a supported type is uploaded via the Oracle Retail Xstore Office File Upload feature.
  - Supported files include Dataloader download files, configuration jar files, debit bin files, encryption cipher files, and update jar files.
  - The file is stored on the Oracle Retail Xstore Office server so that it can be deployed.
2. A file is deployed using the deployment functionality in the File Upload feature.
  - A deployment manifest is created and stored.
  - The file is uploaded to Apache.
3. The deployment is downloaded and applied at each applicable store. See [How a Deployment is Downloaded and Applied](#) for more details.

### Deploying a Data Manager Change

1. A data change, or set of data changes, is made within Oracle Retail Xstore Office's Data Manager feature.
2. The deployment function within the Data Manager feature is used to schedule a deployment of the session.
  - A deployment manifest is created and stored.
  - An update zip file containing a Dataloader download file with the changes made in the Data Manager session is created and uploaded to Apache.
3. The deployment is downloaded and applied at each applicable store. See [How a Deployment is Downloaded and Applied](#) for more details.

### Deploying a Configuration Manager Change

1. A configuration change is made in Oracle Retail Xstore Office's Configuration Manager feature.
  - Changes can be made at a Master Profile (Global) level, at a more granular Profile Group/Profile Element level, or at a Store-Specific level.
2. A deployment of the configurations is scheduled via the Configuration Manager.
  - The configuration change is versioned. See [Version Tracking of Deployments](#).
    - A deployment manifest is created and stored.

- An update zip file is created and uploaded to Apache.

If XML configuration changes are included, they will be transmitted in the form of a jar file containing all XML configuration changes for all profiles.

If data configuration changes are included, they will be transmitted in the form of a DataLoader download file including data changes for the target profile.

3. The deployment is downloaded and applied at each applicable store. See [How a Deployment is Downloaded and Applied](#) for more details.
4. The Master Profile (Global) and any assigned Profile Group/Profile Element details are represented on the store system as configuration path entries (for example, Profile Group: COUNTRY/Profile Element: CANADA would be represented as :COUNTRY/CANADA), and determine which of the configurations in the configuration jar apply to the location.

## Deploying a File Automatically

1. A DataLoader download file, including header details that describe the deployment target area and deployment date, is placed in an automatic deployment location on the Oracle Retail Xstore Office server.
2. Oracle Retail Xstore Office automatically detects the presence of the file and creates a deployment for it, using the provided target details to target the appropriate systems on the appropriate date.
  - A deployment manifest is created and stored.
  - The download file is uploaded to Apache.
3. The deployment is downloaded and applied at each applicable store. See [How a Deployment is Downloaded and Applied](#) for more details.

## Version Tracking of Deployments

Oracle Retail Xstore Office creates and tracks version numbers for each set of configurations that are deployed at the Master Profile (Global) level, at a more granular Profile Group/Profile Element level, or at a Store-Specific level.

1. When a configuration change is saved to a profile (this could be Master/Default, a specific profile element, or a store-specific profile), a version number is assigned to the change.
  - a. Version numbers start at 1 and increment by 1. 1 is the first version for a profile element, 2 is the second version, and so on.
  - b. Additional changes made to the same profile will continue to accumulate with the same version number until deployment for the profile is scheduled.
2. When deployment for a profile is scheduled, the current profile version is "locked" to ensure that no new changes can be made to the version.
3. After a profile version is locked, new changes made to the profile will use a new version number. If version 3 of a profile was locked, new changes will be assigned to version 4 up until the point where deployment for profile version 4 is scheduled.

## How a Deployment is Downloaded and Applied

1. Oracle Retail Xenvironment queries Xcenter for any open deployments at a fixed interval.
2. When Oracle Retail Xenvironment receives deployment details, it processes them in an appropriate manner.
  - An update message is sent to Xcenter to indicate that each manifest has been successfully received.
  - Connectivity details are stored so they can be used to download deployed files.
3. Oracle Retail Xenvironment stores each deployment either for immediate download or download during the closing process.
  - If a deployment is scheduled for immediate download, Oracle Retail Xenvironment will begin to download the file immediately.
  - If a deployment is scheduled for download during the close, Oracle Retail Xenvironment will wait until the nightly closing process is initiated to begin downloading the file.
4. Oracle Retail Xenvironment applies each downloaded deployment at the appropriate time.
  - If a deployment is scheduled to be applied immediately (applies to MNT files, DAT files, and application updates only), Oracle Retail Xenvironment executes the jar. (DataLoader is not used to apply immediate application updates).

### Note:

Oracle Retail Xenvironment will stop Oracle Retail Xstore Point of Service before applying an immediate application update, but it is the responsibility of the code within the jar file to restart Oracle Retail Xstore Point of Service, not Oracle Retail Xenvironment.

- If a deployment is scheduled to be applied during the closing process, it will be handled properly during that process.
  - Dataloader download files are applied via the Dataloader on the lead Oracle Retail Xenvironment register.

If the download data was provided by any feature other than the Configuration Manager, it is loaded into the DB.

If the download data was provided by the Configuration Manager, it is loaded into the DB only if the system's configuration path includes the associated profile.
  - Update jar files are applied by distributing them to each system and executing them.
  - Encryption cipher files are applied by distributing them to each system.
  - Debit bin files are applied by distributing them to each system.
  - Configuration Manager jar files are applied by distributing them to each system.

## Deployment: Basic Troubleshooting

This section describes basic deployment troubleshooting scenarios.

### Deployments not uploaded successfully to apache

When a deployment cannot be uploaded successfully to Apache, the cause will typically be one or more of the following four issues. See the `xcenter-admin.log` and `server.log` files on the Oracle Retail Xstore Office server to determine which of the issues is the cause for the failure.

1. The Apache URL configured in the `xcenter.properties` file is incorrect.
2. The Apache credentials configured in the `xcenter.properties` file are incorrect.
3. The SSL certificate for the Apache server is not located in the truststore file in the `xcenter-config\res\ssl` folder.
4. The Apache server cannot be reached from the Oracle Retail Xstore Office system.

### Deployments not being downloaded and applied by xenvironment

When Oracle Retail Xenvironment is unable to download a deployment from the Apache server, the cause will typically be one or more of the following three issues. See the environment's `process.log` file to determine which of the issues is the cause for the failure.

1. The URL provided in the manifest cannot be reached from the store.
2. The SSL certificate needed to communicate with the Apache server is not present in the `trusted.ca-bundle` file.
3. The Oracle Retail Xenvironment role of one or more of the registers in the store is incorrectly configured.

### Deployments downloaded and applied by xenvironment, no status information appears in xstore office

When Oracle Retail Xenvironment is unable to transmit status information to Xcenter, the cause is typically related to the `DataSourceConfig` file's Xcenter `DataSource` not including a `GetUpdates` context path. Confirm that this path is present and accurate, and add it if it is missing.

# B

## Appendix: Personality Maintenance and Config Paths

This appendix explains how the store personalities set up in Oracle Retail Xstore Office are used to create the config path properties. See [Profile Management](#) for more information about setting up store personalities.

### Config Path Retrieval Process

An empty `configPath.properties` file is part of the POS overlay and can be found in `xstore/configPath.properties` after the installation. When Xenvironment is started for the first time after Xstore Point of Service is installed, the `configPath.properties` file is copied to `environment/res/data/configPath.properties`.

When Xenvironment is used to start Xstore POS or Xstore Mobile (including during Xenvironment startup), Xenvironment will contact Xcenter to check for any updates to the config path settings. If any changes are found, the file in `environment/res/data` will be updated. Xenvironment will update copies of the file in `xstore/configPath.properties` and `xstore-mobile/configPath.properties`. Before retrieving updates, Xenvironment will read the values of `xstore.location.mobile.workstationId.range.start` and `xstore.location.mobile.workstationId.range.end` from `xstore-mobile/system_mobile.properties`. This range will be forwarded to Xcenter to retrieve settings for mobile registers in addition to the current register.

Retrieving updates to `configPath.properties` from Xcenter is enabled by default. To disable the feature, the following setting can be added to the Xenvironment overlay in `version1/actions.properties`:

```
chain.RETRIEVE_CONFIG_PATH.disabled=true
```

If set to true, Oracle Retail Xstore Point of Service will use its current values, for more information, see the [If Not Using Xcenter to Get the Config Path](#) section.

Retrieving config path properties from Xcenter will overwrite any of the same-named properties that already were present in the `configPath.properties` file.

- For the desktop application, the global config path properties and the workstation overrides property for the specific workstation the system represents are retrieved from Xcenter and written to the `configPath.properties` file.
- For the Xstore Mobile server, the global config path properties and the workstation overrides properties for the entire range of mobile device workstations is retrieved from Xcenter and written to the `configPath.properties` file. The range of mobile device workstation IDs is defined in the `system.properties` file using the properties `xstore.location.mobile.workstationId.range.start` and `xstore.location.mobile.workstationId.range.end`.

## At Oracle Retail Xstore Point-of-Service Startup

When Oracle Retail Xstore Point of Service starts, it sends a request to the URL that contains parameters indicating the organization ID, store number, and workstation ID of the machine that is sending the request. (See [Config Path Retrieval Process](#).)

In Xcenter, the config path lookup end-point looks up the store personality based on those parameters and assembles the config path properties from the assigned personality and landscape. The response from Xcenter contains a serialized Java Properties object that contains the appropriate values.

### Note:

If no personality and landscape are assigned to the store, then the specific properties will not be present. Note that in this case, blank values will be used for the `xstore.config.path.base.features` and `xstore.config.path.overrides.workstation.#` properties.

Once the property values from Xcenter are obtained, they are compared to the existing values from the `configPath.properties` files. If either of the property values from Xcenter are different than the property values from the file, the values from Xcenter will be written to the `configPath.properties` file, the `last.updated.date` property will be set to the current date and time, and Oracle Retail Xstore Point of Service will shut itself down and be restarted by the wrapper.

## Till/Register Data

Also during the startup process, till/register data from Xcenter is synchronized with Oracle Retail Xstore Point-of-Service's lead register. Any till/register data that was updated on the store primary is also updated on other workstation databases when the nightly backup and restore process occurs (in an off-line scenario). With this process, it is no longer necessary to manually run till/register setup scripts before starting up the lead register.

## Processing Overview

1. Oracle Retail Xstore Point of Service starts up on the lead register or store primary.
2. During the startup process Oracle Retail Xstore Point of Service compares the till/register data from Xcenter and synchronizes the data on the store primary.

The following data objects are synchronized:

- Store record
- Tax location mapping record
- Corresponding org hierarchy records
- Workstation records
- Tender repository records (till and register records)
- Inventory buckets



- Inventory location buckets

## Xcenter Config Path Properties Assembly

This section describes the assembly of the config path properties.

### Global Configuration Path Properties

Global config path elements are configurations that are loaded once for the entire application and do not differ from workstation to workstation. They define the standard features and functionality for instances of the application.

The global config path is made up by the elements of the `GlobalConfigPathElement` enumeration. This enumeration contains both, the individual global config element definitions as well as the ability to build the currently applicable global config path.

The enum instances `BASE_FEATURES` and `GLOBAL_CONFIG_PATH_EXTENSIONS` point to properties in the `configPath.properties` file. The instances substitute their values with the properties `xstore.config.path.base.features` and `xstore.config.path.global.extensions` when building the global config path.

For more information about the properties `xstore.config.path.base.features` and `xstore.config.path.global.extensions`, see the [xstore.config.path.global.extensions](#) section and the [xstore.config.path.base.features](#) section below.

For more information about all available base global config path elements, see the *Oracle Retail Xstore Point of Service Technical Guide*.

#### `xstore.config.path.global.extensions`

Config path global extensions indicate non-standard config directories that are applied globally and are included in the config path between static retailer global overrides (version1) and Xstore Office-controlled global overrides (MASTER/DEFAULT). The config path global extensions are controlled by the `xstore.config.path.global.extensions` property in the `configPath.properties` file. Since the global extensions property is more of a hidden feature, the property is not maintainable through Xstore Office and must be set manually on any workstation that uses it.

#### `xstore.config.path.base.features`

Base features represent config path elements that are used to enable a certain functionality or feature within the application such as loyalty, a payment processor or integration with external applications such as Customer Engagement, Order Broker, and others.

The base features can be enabled and disabled through the Personality Maintenance feature in Xstore Office. For more information on Personality Maintenance, see the [Personality Maintenance](#) section.

The table below lists all Xstore Point of Service base features that can be enabled and disabled as well as their corresponding config path entries. The enabled base features are represented in the `xstore.config.path.base.features` property in the `configPath.properties` file.

**Table B-1 Base Features and Config Path Entries**

Feature	Sub-Feature	Config Path Entries
Loyalty	NA	:cust/loyalty
	Loyalty Awards	:cust/loyalty/award
Customer Engagement	NA	:relate
	Gift Registry	:cust/registry
	Use IDCS (Identity Cloud Service) for Authorization	:idcs/relate
Order Broker (Cloud)	NA	:order:locate
	Use IDCS (Identity Cloud Service) for Authorization	:idcs/locate
Order Management System	NA	:crosschannelreturn:serenade
	Use IDCS (Identity Cloud Service) for Authorization	:idcs/serenade
Enterprise Inventory Cloud Service(EICS)		:sim:sim/\$FORM_FACTOR\$
	Use IDCS (Identity Cloud Service) for Authorization	:idcs/sim
Retail Extension Module (RXM)	NA	:rxm:rxm/\$FORM_FACTOR\$
Experian Address Verification	NA	:avs
	Experian AddressVerification (Manual) (For SOAP version)	:qas/addressmanual
	Experian Phone Number Verification	:qas/phone
	Experian Email Address Verification	:qas/email
	Experian Address Verification (Auto) (For REST version)	:qas/addressauto
Xcommerce	NA	:xcommerce
Opera Guest Services	NA	:opera
Microsoft SQL Server Support	NA	:dtv/sql/mssql
EFTLink Authorizations	NA	:authprocessor/eftlink
	EFT Link Gift Cards	:authprocessor/eftlink/giftcard
24 x 7 (No Store Closing) Functionality	NA	:24x7
Item Selection Grid (cannot be used with Self Checkout)	NA	:buttonmatrix
Financial Daily Report	NA	:dailyreport
Invoice	NA	:invoice

**Table B-1 (Cont.) Base Features and Config Path Entries**

Feature	Sub-Feature	Config Path Entries
	Global Blue Tax Free (cannot be combined with Planet Tax Free)	:invoice/globalblue
	Panet Tax Free (cannot be combined with Global Blue Tax Free)	:invoice/fintrax
Luxury receipts	NA	:luxuryreceipt
Taxed vouchers	NA	:vouchers

## Workstation Overrides Config Path Properties

The elements for workstation-level configuration overrides are controlled by another property, or a set of properties for mobile servers in the `configPath.properties` file. Since one of these properties indicates all of the override elements for a particular workstation, each override path property name contains the workstation ID to which it applies. The primary purpose of workstation overrides is to support profile group/element pairs that are defined in Xstore Office as part of the profile maintenance. Profile groups and elements are defined and associated with personalities, landscapes, and store personalities in Xstore Office and then each register (or mobile server) in a store downloads its own workstation override config path properties from Xcenter just prior to startup.

### `xstore.config.path.workstation.overrides.X`

The properties containing the workstation overrides config path are `xstore.config.path.workstation.overrides.X` where X is the workstation ID to which the property applies.

The following configuration files support workstation-level overrides. All other configurations will load files only from global config path elements.

- `SysConfig.xml`
- `ActionConfig.xml`
- `OpChainConfig.xml`
- `MenuConfig.xml`
- `PromptConfig.xml`
- `DataFieldConfig.xml`
- forms" directory-based configurations
- `FieldLayoutConfig.xml`
- `FieldDefinitionConfig.xml`
- `FontConfig.xml`
- `ListViewConfig.xml`
- `ContextConfig.xml`
- "componentPropertySet" directory-based configurations

- translations.properties

## xstore.config.path.overrides.store.Y

The config path property, `xstore.config.path.overrides.store.Y`, where Y is the store number, is created. This property contains the profile group and element pairs that make up the personality for a particular store. The files that are located in any of the config path entries defined in this property will be loaded at the global (application) level.

## Oracle Retail Xstore Point-of-Service Config Path Assembly

The default file Xstore Point of Service uses for its config path properties is called `configPath.properties`. The file is located in the root directory on an installed register. As mentioned in the section above, the following three properties form the config path for a given register:

- `xstore.config.path.base.feature`
- `xstore.config.path.global.extensions`
- `xstore.config.path.overrides.workstation.[workstation ID]`

## If Not Using Xcenter to Get the Config Path

If retrieval of the config path from Xcenter is not being used the config path is still assembled in the same manner outlined above. The difference is that the properties `xstore.config.path.base.features` and `xstore.config.path.overrides.workstation.#` (where # is a workstation ID) are not retrieved from Xcenter.

### Note:

If Oracle Retail Xstore Point of Service ever used Xcenter to obtain the config path, and the `configPath.properties` file contains properties those properties will continue to be used even if updating from Xcenter is turned off. They will no longer be updated from Xcenter.

## Oracle Retail Xstore Office Security Settings

**Table B-2 Oracle Retail Xstore Office Security Settings**

Privilege	Description
CFG_PERSONALITY_MAIN TENANCE	Personality maintenance privilege.
CFG_PROFILE_MANAGEM ENT	Top Level profile management menu privilege.
CFG_LANDSCAPE_MAINT ENANCE	Landscape maintenance privilege.

**Table B-2 (Cont.) Oracle Retail Xstore Office Security Settings**

Privilege	Description
CFG_PROFILE_GROUPS	This privilege was renamed from ADMIN_PROFILE_GROUPS in previous versions.
CFG_STORE_PERSONALITY_TIES	Controls access to the store personality maintenance page.

## Resource Bundle Path Consolidation

Resource bundles are loaded based on the config path instead of separate bundle-specific paths. When upgrading to a new Oracle Retail Xstore Point-of-Service version, move any resource bundle files to a config path location or adjust the config path accordingly.

- Translations (was dtv.pos.i18n.translation)
- Phone numbers (was dtv.pos.i18n.phone)
- Hardware (was dtv.pos.i18n.hardware)
- Help (was dtv.pos.i18n.help)
- Email (was dtv.pos.i18n.email)
- Format display (was dtv.i18n.formatDisplay)

## Database Tables

Refer to the *Oracle Retail Xstore Office Database Dictionary Guide* for a complete list of the Oracle Retail Xstore Office database tables.

**Table B-3 cfg\_landscape**

Column	Valid Values	Description
organization_id	int (PK)	Store's organization identifier.
landscape_id	int (PK)	A unique identifier for a landscape.
description	string	A description of the store landscape that is assigned by the user.
comments	string	A comment field for more details.

**Table B-4 cfg\_landscape\_group**

Column	Valid Values	Description
organization_id	int (PK)	Store's organization identifier
landscape_id	int (PK)	The unique ID of the landscape that this register range belongs to.

**Table B-4 (Cont.) cfg\_landscape\_group**

Column	Valid Values	Description
profile_group_id	string(PK)	The profile group ID that this range is assigned to.
profile_group_order	int	Designates the sort order of the groups (profile_group_id) within this landscape. The order affects how the config path is later generated

**Table B-5 cfg\_landscape\_range**

Column	Valid Values	Description
organization_id	int (PK)	Store's organization identifier.
landscape_id	int (PK)	The unique ID of the landscape that this register range belongs to.
profile_group_id	string (PK)	The profile group ID that this range is assigned to.
range_seq	int (PK)	The sequence number of the range for the landscape.
profile_element_id	string	The profile element ID that this range is assigned to.
range_start	int	The start of the register range.
range_end	int	The end of the register range (if only one register is in the range, then this will be the same as range_start).

**Table B-6 cfg\_personality**

Column	Valid Values	Description
organization_id	int	Store's organization identifier.
personality_id	int	A unique identifier for a store's personality.
description	string	A description of the personality that is assigned by the user.
comments	string	A comment field for more details.

**Table B-7 cfg\_personality\_element**

Column	Valid Values	Description
organization_id	int	Store's organization identifier.

**Table B-7 (Cont.) cfg\_personality\_element**

Column	Valid Values	Description
personality_id	int	The unique ID of the personality that this personality profile belongs to.
element_id	varchar(60)	The profile element ID with which this personality is associated.
group_id	varchar(60)	The profile group ID with which this personality is associated.
sort_order	int	The order of elements in the list that will be followed when generating the new configuration path for the store that is assigned to this personality.

**Table B-8 cfg\_store\_personality**

Column	Valid Values	Description
organization_id	int	Store's organization identifier.
personality_id	int	The unique ID of the personality that this personality profile belongs to.
landscape_id	int (PK)	The unique ID of the landscape that this register range belongs to.

**Table B-9 cfg\_personality\_base\_feature**

Column	Valid Values	Description
organization_id (PK)	int	Store's organization identifier.
personality_id (PK)	int	A unique identifier for a store's personality. An alphanumeric field used to enter the short name of the personality.
feature_id (PK)	varchar (200)	A unique identifier for a feature.
sort_order	int	Sort order when displaying code values.

# C

## Appendix: User Interface Configurations

The JSF (JavaServer Faces) technology has been removed from the Oracle Retail Xstore Office application. With the conversion from JSF to GWT (Google Web Toolkit), no new user-modifiable Oracle Retail Xstore Office settings were added to the application. However, Oracle Retail Xstore Office can be "personalized" by adding a background image, changing the color scheme, and configuring the panel display order and content. All menu changes are to data in the `cfg_menu_config` table in the Oracle Retail Xstore Office database. See [Table C-2](#).

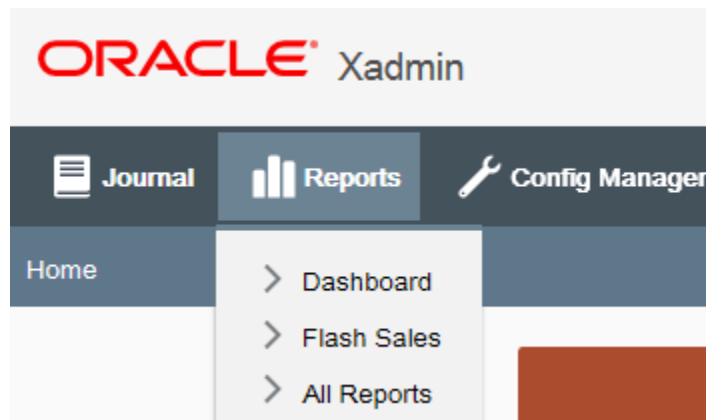
The following changes are documented in this appendix:

- Reports Menu
- Home Page Menu
- Defining Tab Library Properties
- Security Settings

### Reports Menu

The Reports menu (main menu) was restructured as follows:

**Figure C-1 Reports Menu Expanded**



Each report is no longer individually listed under the Reports menu. This was replaced by an All Reports option since the reports are now indexed and searchable within the reports feature. However, it is possible to place a reference to a specific report on the Reports menu. To do this, concatenate the report ID with the standard reports menu name inside of the value of the `cfg_menu_config.menu_name` column for the specific report option. Selecting that specific option will then open the reports feature with the specified report pre-selected and the parameter tab for that report displayed.



## To Reference a Specific Report on the Reports Menu

Any report that is available within the reports feature can be configured as a specific menu option.

1. In the `cfg_menu_config` table, find the report ID for any report by looking for the record in the "REPORT\_VIEWER\_MENU" category with a `menu_type` of "ACTION". The `menu_name` for any record meeting those criteria is the report ID.
2. Concatenate the standard reports menu name with the desired report ID and separate the two with the vertical pipe symbol (|).

Example:

In the following example, assume you want to add the Daily Cash and Sales Report option to the Reports menu.

- The `menu_name` for the "All Reports" option is "REPORT\_VIEWER". This opens the reports feature with nothing selected.
- The report ID for the Daily Cash and Sales Report is "DAILY\_SALES\_CASH\_REPORT".

To create the menu option that opens the Daily Cash and Sales Report, concatenate the standard reports menu name (REPORT\_VIEWER) with the desired report ID (DAILY\_SALES\_CASH\_REPORT) and separate the two with the vertical pipe symbol (|).

The value of the `menu_name` column for the menu option is:

```
REPORT_VIEWER|DAILY_SALES_CASH_REPORT
```

## Home Page Menu

With the removal of JSF, the Oracle Retail Xstore Office user interface was updated throughout to have a new look and feel to enhance the user's experience. With this update, the options available on the Home page are completely configurable. Like the main menu, the contents of the Home page are configurable via the `cfg_menu_config` table in the Oracle Retail Xstore Office database.

## Home Page/Main Menu Options

The grouping and availability of options on the Home page are completely unrelated to the options on the main menu, and are not meant to be the same. The main menu contains all possible options, while the Home page is designed to contain the options that should be readily available to the user upon login.

From a technical perspective, the options that can be configured on the Home page and the main menu each share a value for `menu_name` and, at least in the base, a `security_privilege`.

**Note:**

Sharing a menu name is required. Sharing a privilege, while recommended, is technically optional.

## To Configure the Options on the Home Page

The category for the home page options is "HOME\_PAGE\_MENU". Any record in the `cfg_menu_config` table that has a category of "HOME\_PAGE\_MENU" and a `parent_menu_name` of "ROOT" constitutes a "Home page panel" on the home page. However, simply configuring a root record is not sufficient to make it display.

Following are the requirements to make a panel display on the home page:

- The record for the panel must have either no privilege or a privilege that is part of the current user's role. Each of the six panels in base data have a privilege associated with them. Those privileges are defined in Security Settings below.
- At least one option must be configured as a child of the root option.
- Of the child options that are configured, the user must have access (privilege) to at least one of them. Every individual menu option has a privilege associated with it.

If any of the above conditions are not met, the panel will not be displayed on the home page.

## Panel Information

- The `menu_small_icon` column on the root record controls the image on top of the panel. The value of this column is a relative path to an image that follows the port number in the URL of the application.
- The title column on the root record controls the name of the panel.
- The title column of each child menu option controls the text that shows for each option on a panel.

## Defining Tab Library Properties

The `cfg_tab_property` table defines all configurable tab properties. If the tab property is not defined in this table, then it is not configurable and not displayed on the Oracle Retail Xstore Office Tab Library Configuration page.

**Note:**

To set the default URL, use the `URL_NAVIGATOR` property set in the Oracle Retail Xstore Point of Service `TabConfig.xml`. The default title on the tab is Oracle and the default URL is <http://www.oracle.com>.

**Table C-1** `cfg_tab_property`

Column	Valid Values	Description
<code>tab_id</code>	VARCHAR	Tab ID.
<code>property_id</code>	VARCHAR	Property ID (tab or tabTitle).
<code>display_component</code>	VARCHAR	Widget used to display configurable tab property (TextBox, CompoBox and so on).
<code>value_type</code>	VARCHAR	Determines whether the configurable value is defined in Value or ComplexValue XML tag.
<code>label</code>	VARCHAR	Translation key for label that describes what configurable value is. The label is placed on the left of each display component.
<code>create_date</code>	DATE	Created Date.
<code>create_user_id</code>	VARCHAR	Created User ID.
<code>update_date</code>	DATE	Updated Date.
<code>update_user_id</code>	VARCHAR	Updated User ID.

## Security Settings

The following privileges apply to the home page panels.

**Table C-2** Privileges

Privilege	Description
<code>HOME_PAGE_CONFIG</code>	The privilege that controls access to the Configuration Manager home page panel.
<code>HOME_PAGE_DATA</code>	The privilege that controls access to the Data Management home page panel.
<code>HOME_PAGE_DEPLOY</code>	The privilege that controls access to the Deployment Manager home page panel.
<code>HOME_PAGE_SUPPORT</code>	The privilege that controls access to the Support Tools home page panel.
<code>HOME_PAGE_REPORTS</code>	The privilege that controls access to the Reports home page panel.
<code>HOME_PAGE_SYSTEM</code>	The privilege that controls access to the System home page panel.
<code>RPT_GENERAL_ACCESS</code>	The privilege that controls access to the All Reports menu option.

Table C-3 `cfg_menu_config`

PK	Attribute/ Logical Rolename	Datatype	NULL?	Definition
X	category	VARCHAR (60)	NO	Menu category.
X	menu_name	VARCHAR (100)	NO	Name of menu.
NA	parent_menu_name	VARCHAR (100)	YES	Name of parent menu.
NA	config_type	VARCHAR (120)	YES	Configuration type for menu (if applicable).
NA	title	VARCHAR (60)	YES	Translation key for display title of menu.
NA	menu_type	VARCHAR (30)	YES	Specifies the type of menu (REDIRECT_ACTION, LINK, ACTION, or LINK_GROUP).
NA	sort_order	INTEGER	YES	Sort order for menu display.
NA	view_id	VARCHAR (200)	YES	Relative path to view file associated with menu (only applicable to menus with menu_type of REDIRECT_ACTION and LINK).
NA	action_expression	VARCHAR (200)	YES	EL or method chain to execute when menu is selected.
NA	active_flag	BIT	YES	Determines whether menu is active or not.
NA	propagation	VARCHAR (30)	YES	Seam conversation propagation strategy to use when linking to another view.
NA	security_privilege	VARCHAR (30)	YES	Security privilege required to access menu.
NA	custom_datasource_class	VARCHAR (200)	YES	Custom data source to use with report associated with menu (if applicable).
NA	custom_datasource_method	VARCHAR (30)	YES	Custom data source to use with report associated with menu (if applicable).
NA	menu_small_icon	VARCHAR (254)	YES	Relative path to image file to use as an icon for menu.
NA	menu_separator	BIT	YES	Unused

**Table C-3 (Cont.) cfg\_menu\_config**

<b>PK</b>	<b>Attribute/ Logical Rolename</b>	<b>Datotyp</b>	<b>NULL?</b>	<b>Definition</b>
NA	description	VARCHAR (MAX)	YES	Text description of Menu Item.
NA	create_date	DATETIME	YES	Date the table row was created.
NA	create_user_id	VARCHAR (30)	YES	User responsible for creating the table row.
NA	update_date	DATETIME	YES	Date the table row was most recently updated.
NA	update_user_id	VARCHAR (30)	YES	User responsible for updating the table row.

# D

## Appendix: Enrollment with Cloud Services

This chapter describes how to enroll Xstore Office On-Premise with other Retail Cloud Services and how to enroll Xstore Stores in Xstore Office Cloud Service through the Xstore Office UI (On-Premise).



### Note:

For more information about how to configure web service authentication for the Retail Omnichannel products, like Order Management System Cloud Service, Order Broker Cloud Service and Customer Engagement Cloud Services, see the *Oracle Retail Omnichannel Web Service Authentication Configuration Guide* (Doc ID 2728265.1) on My Oracle Support.

## Enrolling Xstore Office On-Premise with Retail Cloud Services

This section describes how to enroll Xstore Office On-Premise with other Retail Cloud Services.

## Configuring Xstore Office On-Premise with IDCS

To configure Xstore Office On-Premise with IDCS follow the steps listed below:

1. Add the following entries to the `xcenter.properties` file:
  - Add `:idcs` to the config path `global.extensions`.
  - Configure the `idp.connectionURL`.
  - Add `:idcs/relate` to the config path `base.features` to broadcast poslog data to Customer Engagement using IDCS.
  - Add `:idcs/locate` to the config path `base.features` to send item and inventory data to Order Broker using IDCS.
  - For Order Broker configurations, `cloud.http.locate.oauth2` needs to be set to `true` in the `xcenter.properties` file.
2. For Customer Engagement configurations, the `relateAuthHandlerResolver` bean needs to be commented out in the `xcenter-spring-beans.xml` file:

```
<!--  
  <bean id="relateAuthHandlerResolver"  
  
  class="com.micros_retail.xcenter.broadcast.relate.RelateAuthHandlerResolver">  
    <property name="relateOrgCode" value="ORGCODE" />  
    <property name="encryptedUsername" value="encryptedUsername" />  
    <property name="encryptedPassword" value="encryptedPassword" />  
  </bean>  
-->
```

```
</bean>
-->
```

3. Then submit and store credentials which will allow Xstore Office On-Premise to communicate with Identity Cloud Service (IDCS).

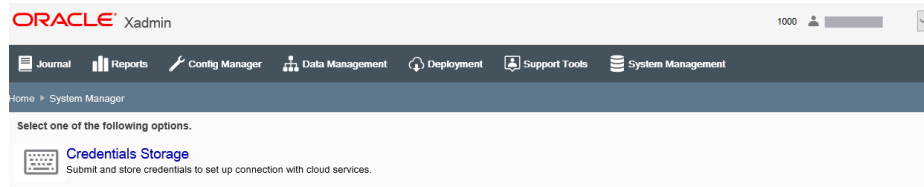
 **Note:**

These credentials need to be generated in another cloud application. The cloud application needs to grant access to Xstore Office On-Premise to complete the communication setup.

- a. From the Oracle Retail Xstore Office menu, select **System Management**, and then select **System Manager**. From the System Manager menu, select **Credentials Storage**.

For more information on how to submit and store credentials, see the [Credentials Storage](#) section in chapter [System Management](#).

**Figure D-1 Credentials Storage**

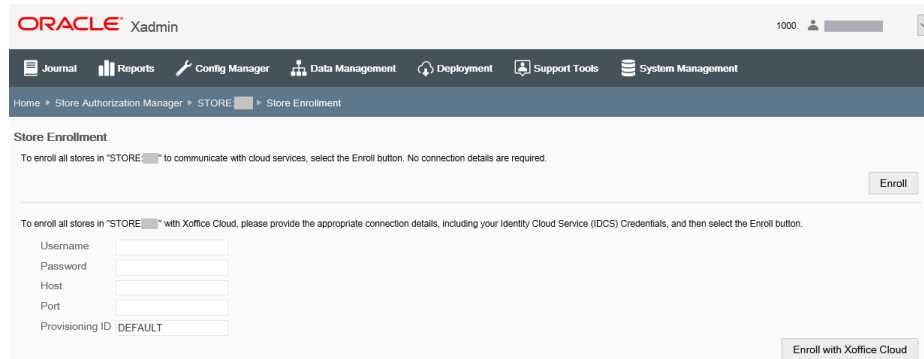


## Configuring Xstore Registers for IDCS

To configure Xstore registers for IDCS follow the steps listed below:

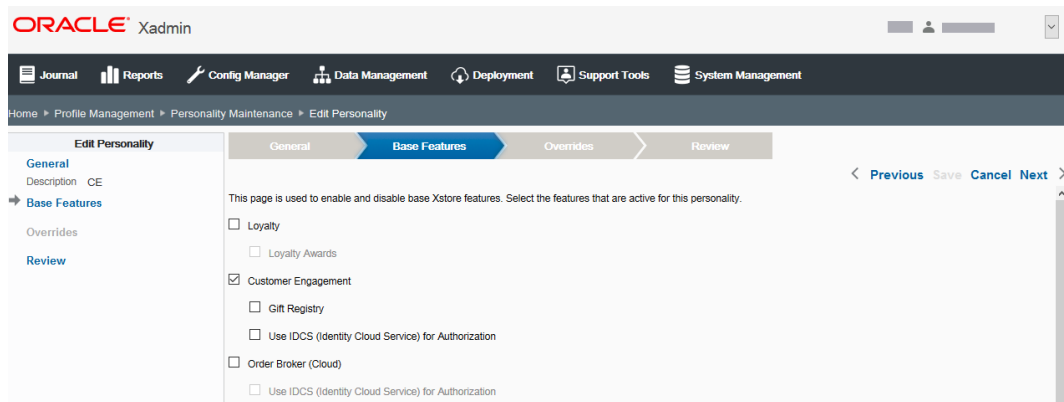
1. Enroll one or all stores in an organization node with cloud services.
  - a. From the Oracle Retail Xstore Office menu, select **System Management**, then select **Store Authorization Manager**. From the Store Authorization Manager menu, select **Store Authorization Manager**. Select an organization node and press **Next**. The Store Enrollment Screen is displayed.

**Figure D-2 Store Enrollment — Configure Registers for IDCS**



- b. Select **Enroll** to enroll the selected stores to communicate with Cloud Services. No connection details are required.  
  
For more information on how to enroll stores with cloud services, see the [Store Enrollment](#) section in chapter [System Management](#).
2. After the deployment of the store enrollment is complete, use the Personality Maintenance functionality to configure IDCS access for a service, for example Customer Engagement or Order Broker.
  - a. From the Oracle Retail Xstore Office menu, select **Config Manager — Profile Management**, or click the Profile Management link in the Configuration Manager panel. From the Profile Management page, select **Personality Maintenance** add a new personality.
  - b. At the Base Features tab, enable IDCS access for a service.

**Figure D-3 Personality Maintenance Screen — Base Features Enable IDCS**



For more detailed information on how to enable IDCS access for a service, see the [Personality Maintenance](#) section in chapter [Configurator](#).

3. The Xservices must be manually configured with the correct configuration path to use IDCS for the various services. Add the following entries to the `xservices.properties` file:
  - For IDCS Access to Customer Engagement add `:idcs/relate` to the config path base features.
  - For IDCS Access to Order Broker add `:idcs/locate` to the config path base features.

## Enrolling Xstore Stores in Xstore Office Cloud Service

Xstore Stores can be enrolled in Xstore Office Cloud Service through the Xstore Office On-Premise UI.



 **Note:**

Xstore Office Cloud Service is provisioned with IDCS and has a client ID/provisioning ID. For more information on Xstore Office Cloud Service provisioning, see the *Oracle Retail Xstore Office Cloud Service Security Guide* and the *Oracle Retail Xstore Office Cloud Service Administration Guide*. You need to grant access to the parent client ID in each integrating application before enrolling stores.

1. Enroll all stores in the organization node with an Xstore Office Cloud Service environment.
  - a. From the Oracle Retail Xstore Office menu, select **System Management**, then select **Store Authorization Manager**. From the Store Authorization Manager menu, select **Store Authorization Manager**. Select an organization node and press **Next**. The Store Enrollment Screen is displayed.
  - b. Enroll all stores in the organization node with an Xstore Office Cloud Service environment.

Collect the following data prior to starting the Xoffice Cloud Enroll process.

    - Xstore Office Cloud Hostname and Port. The Customer Administrator can look this up by logging into their Cloud Service Account.
    - IDCS User credentials: Username and Password of any IDCS user belonging to the provisioned IDCS tenant.
  - c. Enter the connection details for the Xcenter cloud Xstore Office Cloud URL.
  - d. Then select Enroll with Xoffice Cloud to validate credentials and enroll the location(s). A deployment will be created for each location in the selected organization node to be applied during the next store close.

At the next store close, all POS applications will be configured for Xstore Office Cloud service. All systems will be restarted.

For more detailed information on how to enroll stores with an Xstore Office Cloud service environment, see the [Store Enrollment](#) in the [System Management](#) chapter.
2. Additionally, use the Personality Maintenance functionality to configure IDCS access for a service, for example Customer Engagement or Order Broker.
  - a. From the Oracle Retail Xstore Office menu, select **Config Manager - Profile Management**, or click the Profile Management link in the Configuration Manager panel. From the Profile Management page, select **Personality Maintenance** add a new personality.
  - b. At the Base Features tab, enable IDCS access for a service.

 **Note:**

For more detailed information on how to enable IDCS access for a service, see the [Personality Maintenance](#) section in chapter [Configurator](#).

# E

## Appendix: Accessibility

For more information about the accessibility features available in Oracle Retail Xstore Office, see the *Oracle Retail Xstore Suite Implementation and Security Guide*.

# F

## Appendix: Xcenter Attachment Export

This section describes the Xcenter Attachment Export feature.

### Overview

This Xcenter feature extracts files from the `trn_trans_attachments` table and places them in a configured location on the filesystem.

The retailer can access the exported files in the file system via REST webservice call.

Several functions are exporting data in the `trn_trans_attachments` table. As base we are providing a basic configuration for Germany TSE data as reference. The retailer can configure the export filename, export directory and separate configuration to trigger each attachment type export. These configuration will be maintained in `xcenter-spring-bean.xml`.

### Property Settings

The property `xst.fileresource.path.attachment` in the `xcenter.properties` file defines the directory location, which will be the root directory for all attachment export.

### Spring Settings

All configurations for attachment exports are carried out by using Spring beans.

### Configuring an Attachment Export

An attachment type is configured by the class `AttachmentExportConfig` for each attachment type and passed as a property to the class `AttachmentExportDataTask` along with export URI and the organization id which are configured in `xcenter.properties` file.

`AttachmentExportDataTask` bean id is the value for the key "integrationConfigId" to schedule the spring job.

**Table F-1 AttachmentExportConfig Settings**

Type	Position	Type	Meaning
Property	<code>attachmentType</code>	String	The <code>attachmentType</code> value should map the <code>ATTACHMENT_TYPE</code> column value of the <code>TRN_TRANS_ATTACHMENT</code> table.

**Table F-1 (Cont.) AttachmentExportConfig Settings**

Type	Position	Type	Meaning
Property	fileName	String	The file name for the extracted attachment. The name can be generated using the transaction attributes, tokens which are enclosed within parenthesis i.e \$ {PosTransactionModel Property} are replaced with values from PosTransactionModel object and other tokens are treated as a static value. For organization ID 1000 and store ID 703 and transaction sequence 1539 the following file name configuration will generate file name 1000-703-1-TSE_STORAGE_BYTES-1539.tar.gz
Property	extractDirectory	String	The attachment extract directory is relative to the path {xst.filesresource.path.attachment} configured in xcenter.properties file.

**Table F-2 AttachmentExportData Task Settings**

Type	Position	Type	Meaning
Property	organizationId	String	Organization id property {xcenter.org.id} configured in xcenter.properties file.
Property	attachmentConfig	bean	The value of this property should be the same as the bean name for the relevant AttachmentExportConfig

**Table F-2 (Cont.) AttachmentExportData Task Settings**

Type	Position	Type	Meaning
Property	exportUri	String	The export URI property {xst.filesresource.path.attachment} configured in xcenter.properties file.

**Table F-3 Trigger Settings**

Type	Position	Type	Meaning
Property		String	The value of this property should be the same as the bean name for the relevant AttachmentExportDataTask.
Property		String	Cron expression. By default Configured to run once every 24 hours at 06:00.
Property		String	Time zone property. Timezones are set to UTC/GMT and cronExpressions are expected to represent that time..

To enable the attachment export, add the configured JobDetailFactoryBean to jobsList and CronTriggerFactoryBean to triggersList as reference property list for relevant attachment type.

Export URI:

```
https://{hostname}:{port}/xcenter/rest/attachment
```

Example: The following are configurations which need to be done for each attachment type to export it to filesystem in xcenter-spring-beans.xml. The configuration below is for Germany TSE export.

```
<bean id="tseAttachmentExportConfig"
class="com.micros_retail.xcenter.fiscalization.attachment.AttachmentExportCon
fig">
  <!-- The attachmentType value should maps to the ATTACHMENT_TYPE column
value of the TRN_TRANS_ATTACHMENT table. -->
  <property name="attachmentType" value="TSE_STORAGE_BYTES" />
  <!-- The file name for the extracted attachment. The name can be
generated using the transaction attributes,
```

```

        tokens which are enclosed within parenthesis i.e $
        {PosTransactionModelProperty} are replaced with values from
        PosTransactionModel
        object and other tokens are treated as a static value. For
        organization ID 1000 and store ID 703 and transaction
        sequence 1539 the following file name configuration will
        generate file name 1000-703-1-TSE_STORAGE_BYTES-1539.tar.gz -->
        <property name="fileName" value="{organizationId}-${
        {retailLocationId}-${workstationId}-${attachmentType}-${
        {transactionSequence}-${TSE_FISCAL_NUMBER}.tar.gz" />
        <!-- The attachment extract directory is relative to the path
        {xst.fileresource.path.attachment} configured in xcenter.properties -->
        <property name="extractDirectory" value="{organizationId}/${
        {retailLocationId}/${workstationId}/${attachmentType}" />
    </bean>

    <bean id="tseAttachmentExportDataTrigger"
    class="org.springframework.scheduling.quartz.CronTriggerFactoryBean">
        <property name="jobDetail" ref="tseAttachmentExportDataJob" />
        <!-- Configured to run once every 24 hours at 06:00. -->
        <property name="cronExpression" value="0 0 6 * * ?" />
        <!-- Timezones are set to UTC/GMT and cronExpressions are expected
        to represent that time. -->
        <property name="timeZone" value="UTC" />
    </bean>

    <bean id="tseAttachmentExportDataTask"
    class="com.micros_retail.xcenter.fiscalization.attachment.AttachmentExp
    ortDataTask">
        <property name="organizationId"
        value="#{T(com.micros_retail.xcenter.bootstrap.XcenterProperties).getSt
        ring('xcenter.org.id')}" />
        <!-- The value of this property should be the same as the bean
        name for the relevant tseAttachmentExportConfig -->
        <property name="attachmentConfig"
        ref="tseAttachmentExportConfig" />
        <property name="exportUri"
        value="#{T(com.micros_retail.xcenter.bootstrap.XcenterProperties).getSt
        ring('xst.fileresource.path.attachment')}" />
    </bean>

    <bean id="tseAttachmentExportDataJob"
    class="org.springframework.scheduling.quartz.JobDetailFactoryBean">
        <property name="jobClass"
        value="com.micros_retail.xcenter.integration.IntegrationJob" />
        <property name="jobDataAsMap">
            <map>
                <entry key="category" value="INTEGRATION" />
                <!-- The value of this property should be the same as the
                bean name for the relevant tseAttachmentExportDataTask -->
                <entry key="integrationConfigId"
                value="tseAttachmentExportDataTask" />
            </map>
        </property>
        <property name="durability" value="true" />

```

```
    <property name="description" value="Export Transaction Attachment  
Data" />  
</bean>
```

# G

## Appendix: Tax Service Integration Avalara

This section describes the configurations for the tax service integration Avalara.

### Overview

Avalara is the external tax service for Xstore. Avalara provides tax data in mnt data format. Xstore Office reaches out to this external tax service to fetch data periodically or on-demand. Xstore Office uses auto drop file deployments to send this data across all stores in the organization.

### Avalara - Scheduled Quartz Jobs

The `scheduledAvataxDatFetchJob` quartz job fetches data from the Avalara tax service and auto-deploys the data to stores in the organization.

```
<bean id="scheduledAvataxDatFetchJob_1000"
class="org.springframework.scheduling.quartz.JobDetailFactoryBean">
  <property name="jobClass"
value="com.micros_retail.xcenter.integration.IntegrationJob" />
  <property name="jobDataAsMap">
    <map>
      <entry key="category" value="INTEGRATION"/>
      <!-- The value of this property should be the same as the bean
name for the relevant scheduledAvataxDatFetchTask -->
      <entry key="integrationConfigId"
value="scheduledAvataxDatFetchTask" />
    </map>
  </property>
  <property name="durability" value="true"/>
  <property name="requestsRecovery" value="true"/>
  <property name="description" value="Scheduled fetch Tax Data from
Avalara"/>
</bean>
```

The `ExecScheduledAvataxDatFetchTask` quartz job is the integration task that fetches the Avalara tax data and propagates it to stores of the organization.

```
<bean id="scheduledAvataxDatFetchTask_1000"
class="com.micros_retail.xcenter.avatax.ExecScheduledAvataxDatFetchTask">
  <property name="organizationId" value="1000" />
  <property name="avataxProperties" ref="avataxProperties" />
</bean>
```



The `scheduledAvataxDATAFetchTrigger` quartz job schedules the job to trigger on a certain date and time.

```
<bean id="scheduledAvataxDATAFetchTrigger_1000"
class="org.springframework.scheduling.quartz.CronTriggerFactoryBean">
  <property name="jobDetail"
ref="scheduledAvataxDATAFetchJob_1000" />
  <!-- Configured to run on 25th of every month at 21:00. -->
  <property name="cronExpression" value="0 0 21 25 * ?" />
  <!-- Timezones are set to UTC/GMT and cronExpressions are
expected to represent that time. -->
  <property name="timeZone" value="UTC" />
</bean>
```

## xcenter.properties Settings

This section lists the `xcenter.properties` settings for the Avalara tax data service.

(Continued)xcenter.properties - Avalara Tax Data Service

**Table G-1** xcenter.properties Settings

Setting	Valid Values	Description
<code>avataxDATA.connectionURL</code>	<code>https://avalara-host</code>	Endpoint for Avalara tax data service
<code>avataxDATA.connection.servicePath.prefix</code>	<code>/api/v2/content/data/companies</code>	REST GET web method's @uri
<code>avataxDATA.connection.username</code>	<code>username</code>	AccountId provided by Avalara
<code>avataxDATA.connection.password</code>	<code>password</code>	License key provided by Avalara
<code>avataxDATA.orgCompanyIds</code>	<code>1000:257638,2000:27648</code>	Mapping of Xstore Office organization to Avalara <code>companyId</code> . It is comma separated entries for each mapping.
<code>avataxDATA.onDemand.enabled</code>	<code>true/false</code>	Is Avalara On-Demand functionality enabled for Xadmin.
<code>avataxDATA.config.getDelta</code>	<code>true/false</code>	If true, the Xcenter will fetch Delta of the Tax Data from External integration on scheduled basis.
<code>avataxDATA.ping.servicePath.prefix</code>	<code>/api/v2/utilities/ping</code>	
<code>avataxDATA.config.download_time</code>	<code>STORE_CLOSE</code> or <code>IMMEDIATE</code>	
<code>avataxDATA.config.accountId</code>	<code>2001508678</code>	

# H

## Appendix: Pay By Link (PBL) Integration with Adyen Payment Provider

This section describes the Pay By Link (PBL) Integration with Adyen Payment Provider.

### Overview

Xstore can now support Pay By Link tenders, allowing customers to tender for transactions remotely and also allowing payment using a number of alternative payment types as supported by the payment provider and retailer.

The Pay by Link functionality allows a sales associate to provide a way for a customer to pay for merchandise without ever handing over any sort of payment item or communicating any sort of payment information to the sales associate.

Instead, the customer will be presented with a link (url) which they can visit in order to enter their payment information securely on the payment providers payment checkout webpage, and pay for their merchandise.

Two types of Pay By Link tenders are supported:

- **PBL Customer Not Present** This tender is typically used when the customer is not present in the store, but is instead on the phone to the sales assistant, creating an order such as Send Sale. The PBL link (url) is emailed to the customer, which the customer will click, taking them to the payment providers payment checkout webpage.

- **PBL On the Payment Terminal**

This tender is typically used when the customer is in the store and wishes to pay with an alternative tender such as various wallet or other payment types.

The PBL link (url) is displayed on the payment terminal as a QR Code, that the customer can scan using their cell phone, taking them to the payment providers payment checkout webpage.

An Xcenter webservice needs to be enabled and configured, to process completed PBL Customer Not Present payments in Xstore. This service processes PBL payment result notifications from the payment provider.

### Security Considerations

The new REST service mentioned in the Web Service Changes section below is exposed for On-Premise installations of Xcenter.

On-Premise installations of Xcenter use basic authentication. For the basic authentication for the Adyen service, a new user role and a new user will need to be setup in the application server container.

This new user is the one that will be given to Adyen, so that Adyen may contact the service that is exposed for them (and only the service that is exposed for them).

A security role named AdyenUsers has been defined in Xcenter's web.xml file and associated with authentication for the Adyen notification service. The role and the user will need to be setup depending on the container that a retailer is using. Below are some basic directions on how to do that setup. More specific information about each container can be found in the container's own documentation.

## Tomcat

In the directory where Tomcat is installed, go to the conf directory and add the new role and user to the tomcat-users.xml file.



### Note:

AdyenUsers is the name of the role that must be used.

```
tomcat-users.xml excerpt:  
<role rolename="AdyenUsers"/>  
<user username="adyen" password="adyen" roles="AdyenUsers"/>
```

## Jetty

Run the following command from a command prompt, where <path-to-dtv-password.jar> is the directory where the file dtv-password.jar exists.

title Prompt for New Jetty Password:

```
java -cp <path-to-dtv-password.jar>/dtv-password.jar  
oracle.retail.xstore.passwd.impl.Ssha2Hasher
```

That will prompt you for your Adyen user's password. Type your new password and press Enter.

The output will be a hashed password that you need to copy into the passwd file in the etc directory where Jetty is installed, along with other user information.

The format of the line that should be added to the file is as follows, with \$ {adyenAuthUserName} being replaced with the Adyen user name and \$ {xcenterAuthPasswordHash} being replaced with the hashed password that was output by the command above.

AdyenUsers is the name of the security role and that is the value that must be used for it.

title Line Format for Jetty passwd File:

```
${xcenterAuthUserName}:$  
{xcenterAuthPasswordHash}:92464520400:0:0:AdyenUsers
```

## Weblogic

The *Xstore Suite Implementation and Security Guide*, section Install an Application Server: WebLogic, Jetty, or Tomcat, has instructions on how to use WebLogic's admin tools to add users and groups for the standard Xcenter users.

The same instructions can be followed to add the appropriate Ayden user, substituting AdyenUsers for XcenterUsers as the name of the group.

## Web Service Changes

In order to be notified when a PBL payment has been made, Adyen requires that a service be exposed to which payment result notifications can be sent. This service has been added to Xcenter.

Service Name: PayByLinkNotificationResource

Version: V1

Description: A RESTful web service endpoint that receives notifications from Adyen about payments that have been made using payment links. The service URL that needs to be configured in Adyen is:

```
<xcenter_protocol>://<xcenter_host>:<xcenter_port>/xcenter/rest/adyen/v1/  
<organization_id>/notification
```

## Additional Details

The Pay By Link notification service in Xcenter is currently only available for On-Premise Xcenter installations, since they use basic auth and not OAuth.

Pay By Link tenders are not available in Xstore by default. In order to make the Pay By Link tenders available for use within Xstore, the "Payment By Link Tendents" base feature must be enabled in Xadmin.

At a technical level, this adds the config path entry ":paybylink" to the xstore.config.path.base.features property in configPath.properties.

Xstore queries Xcenter periodically for payment results. The interval for this result polling is specified on a Spring scheduled task configuration.

A copy of the base version of the Spring bean definition is included below.

If you wish to override it to change the polling interval, you can copy this entire bean definition to a "spring" sub-directory in a config override directory (like :localconfig/spring/local-overrides.xml or whatever your local override directory is).

Spring Scheduled Tasks Bean Definition for Xstore:

```
<task:scheduled-tasks scheduler="springTaskScheduler">  
  <task:scheduled ref="xenvPasswordFileCreationTask" method="run" fixed-  
delay="900000" initial-delay="0" />  
  <task:scheduled ref="autoClockOutTask" method="reclockFromMidnight"
```

```
cron="0 0 0 * * ?" />
  <task:scheduled ref="environmentHelper"
method="hasUpdateGracePeriodExpired" initial-delay="60000" fixed-
delay="20000" />
  <!-- 86400000 millis is 24 hours -->
  <task:scheduled ref="sensitiveDataLoggingCheck" method="check" fixed-
rate="86400000" initial-delay="0" />
  <!-- 3600000 is once per hour -->
  <task:scheduled ref="extensionStoreConnectivityCheck" method="check"
fixed-delay="3600000" initial-delay="10000" />
  <task:scheduled ref="payByLinkAdyenResultCheckTask"
method="checkAndProcessResults" fixed-delay="900000" initial-
delay="120000" />
</task:scheduled-tasks>
```

# Glossary

**airside locations**

Retail locations inside the secured area of the airport.

**configuration jar file**

A Java jar file containing a set of Oracle Retail Xstore Point-of-Service configuration files.

**dataloader download file**

A file containing data in delimited text format, which will be loaded into database tables using the DataLoader application.

**debit bin file**

A text file containing a set of range and format data for accepted debit cards.

**deployment manifest**

An XML document containing details for a deployment. These details include the location of the deployed file, a type distinction for the file, and instructions to indicate when the file should be downloaded and when it should be applied.

**encryption cipher file**

An encryption key file.

**event store**

An event store has a separate store number from all brick-and-mortar locations.

**extension store**

An extension store shares a store number with a specific brick-and-mortar location.

**httpd**

The Apache HyperText Transfer Protocol (HTTP) server program.

**landscape**

Defines the registers used within a store and specifies the register numbers and functions.

**personality**

A grouping of at least one or many Profile Group and Profile Element combinations in an ordered list that work together to define a store.

**profile**

A target group for configurations. A profile may either be the Master profile, which represents the default set of configurations for all store systems, or a Profile Group/ Profile element combination that includes configurations for a specific group of store systems.

**profile element**

The child property associated with the Profile Group; for example, Location= Ohio, California, Iowa, and so on.

**profile group**

A collection of configuration elements by type; for example Location, Register Type, Store Type, and so on.

**store personality**

A personality/landscape pairing to define a store; used to create the configuration paths specified in configPath.properties.

**target group**

The location, or set of locations, that will receive a deployment.

**update jar file**

An executable application update.

**Oracle Retail Xenvironment lead register**

The Oracle Retail Xenvironment lead register system controls the store closing process and is responsible for querying Xcenter (a part of Oracle Retail Xstore Office) for new deployments, downloading deployments and distributing them to other

registers in the store, and for sending feedback pertaining to the status of deployments to Xcenter.

**Oracle Retail Xstore Point-of-Service primary register**

The Oracle Retail Xstore Point-of-Service lead register system is used to open and close the retail location.

**Xcenter (a part of Oracle Retail Xstore Office)**

The Xcenter application (a part of Oracle Retail Xstore Office) is a Java and XML/SOAPbased messaging framework that runs on the Jetty application server, available to Oracle Retail Xstore Point of Service for reading and writing of data. Xcenter provides Xcenter data access through Jetty. The Xcenter server interfaces to Xcenter (Home Office server) and to the point-of-sale client module (Store).

The Xcenter Database is a central data repository containing consolidated data from specified database tables in every store.