

# Oracle Server X9-2 Service Manual



F23495-04  
August 2023



Oracle Server X9-2 Service Manual,

F23495-04

Copyright © 2022, 2023, Oracle and/or its affiliates.

Primary Author: Mark McGothigan

This software and related documentation are provided under a license agreement containing restrictions on use and disclosure and are protected by intellectual property laws. Except as expressly permitted in your license agreement or allowed by law, you may not use, copy, reproduce, translate, broadcast, modify, license, transmit, distribute, exhibit, perform, publish, or display any part, in any form, or by any means. Reverse engineering, disassembly, or decompilation of this software, unless required by law for interoperability, is prohibited.

The information contained herein is subject to change without notice and is not warranted to be error-free. If you find any errors, please report them to us in writing.

If this is software, software documentation, data (as defined in the Federal Acquisition Regulation), or related documentation that is delivered to the U.S. Government or anyone licensing it on behalf of the U.S. Government, then the following notice is applicable:

U.S. GOVERNMENT END USERS: Oracle programs (including any operating system, integrated software, any programs embedded, installed, or activated on delivered hardware, and modifications of such programs) and Oracle computer documentation or other Oracle data delivered to or accessed by U.S. Government end users are "commercial computer software," "commercial computer software documentation," or "limited rights data" pursuant to the applicable Federal Acquisition Regulation and agency-specific supplemental regulations. As such, the use, reproduction, duplication, release, display, disclosure, modification, preparation of derivative works, and/or adaptation of i) Oracle programs (including any operating system, integrated software, any programs embedded, installed, or activated on delivered hardware, and modifications of such programs), ii) Oracle computer documentation and/or iii) other Oracle data, is subject to the rights and limitations specified in the license contained in the applicable contract. The terms governing the U.S. Government's use of Oracle cloud services are defined by the applicable contract for such services. No other rights are granted to the U.S. Government.

This software or hardware is developed for general use in a variety of information management applications. It is not developed or intended for use in any inherently dangerous applications, including applications that may create a risk of personal injury. If you use this software or hardware in dangerous applications, then you shall be responsible to take all appropriate fail-safe, backup, redundancy, and other measures to ensure its safe use. Oracle Corporation and its affiliates disclaim any liability for any damages caused by use of this software or hardware in dangerous applications.

Oracle®, Java, and MySQL are registered trademarks of Oracle and/or its affiliates. Other names may be trademarks of their respective owners.

Intel and Intel Inside are trademarks or registered trademarks of Intel Corporation. All SPARC trademarks are used under license and are trademarks or registered trademarks of SPARC International, Inc. AMD, Epyc, and the AMD logo are trademarks or registered trademarks of Advanced Micro Devices. UNIX is a registered trademark of The Open Group.

This software or hardware and documentation may provide access to or information about content, products, and services from third parties. Oracle Corporation and its affiliates are not responsible for and expressly disclaim all warranties of any kind with respect to third-party content, products, and services unless otherwise set forth in an applicable agreement between you and Oracle. Oracle Corporation and its affiliates will not be responsible for any loss, costs, or damages incurred due to your access to or use of third-party content, products, or services, except as set forth in an applicable agreement between you and Oracle.

# Contents

## Using This Documentation

---

Product Documentation Library	xi
Feedback	xi

## 1 About the Oracle Server X9-2

---

Product Description	1-1
Front and Back Panel Components	1-2
Front Panel Controls and Indicators	1-2
Back Panel Components and Cable Connections	1-3
About System Components	1-4
Illustrated Parts Breakdown	1-4
Customer-Replaceable Units	1-6
Field-Replaceable Units	1-6

## 2 Troubleshooting and Diagnostics

---

Troubleshooting Server Component Hardware Faults	2-1
Troubleshooting Server Hardware Faults	2-1
Basic Troubleshooting Process	2-1
Troubleshoot Hardware Faults Using the Oracle ILOM Web Interface	2-2
Troubleshooting and Diagnostic Information	2-4
Troubleshooting Using the Server Front and Back Panel Status Indicators	2-4
Server Boot Process and Normal Operating State Indicators	2-4
Server System-Level Status Indicators	2-5
Server Fan Status Indicators	2-7
Storage Drive Status Indicators	2-7
Power Supply Status Indicators	2-8
Network Management Port Status Indicators	2-8
Ethernet Ports Status Indicators	2-9
Motherboard Status Indicators	2-9
Troubleshooting System Cooling Issues	2-10
Troubleshooting Power Issues	2-12

Managing Server Hardware Faults Through the Oracle ILOM Fault Management Shell	2-14
Troubleshooting With Diagnostic Tools	2-14
Diagnostic Tools	2-14
Diagnostic Tool Documentation	2-15
Attaching Devices to the Server	2-16
Attach Devices to the Server	2-16
Back Panel Connector Locations	2-17
Configuring Serial Port Sharing	2-18
Assign Serial Port Output Using the Oracle ILOM CLI	2-18
Assign Serial Port Output Using the Oracle ILOM Web Interface	2-19
Server Operating System Names for the NVMe Storage Drives	2-19
Ethernet Device Naming	2-20
Ethernet Port Device Naming	2-20
MAC Address Mapping to Ethernet Ports	2-21
Back Panel Pinhole Switch	2-21
Getting Help	2-21
Contacting Support	2-22
Locating the Chassis Serial Number	2-22
Auto Service Requests	2-23

### 3 Preparing for Service

---

Safety Precautions	3-1
Safety Symbols	3-1
Electrostatic Discharge Safety	3-2
FRU Key Identity Properties (KIP) Automated Update	3-3
Required Tools	3-4
Preparing the Server for Component Replacement	3-4
Powering Down the Server	3-4
Power Down Server Gracefully Using the Oracle ILOM CLI	3-5
Power Down Server Gracefully Using the Oracle ILOM Web Interface	3-6
Power Down Server Gracefully Using the On/Standby Button	3-7
Power Down the Server for Immediate Shutdown Using the On/Standby Button	3-7
Power Down the Server for Immediate Shutdown Using the Oracle ILOM CLI	3-8
Power Down the Server for Immediate Shutdown Using the Oracle ILOM Web Interface	3-9
Disconnect Cables From the Server	3-10
Extend the Server to the Maintenance Position	3-10
Remove the Server From the Rack	3-12
Take Antistatic Measures	3-12

## 4 Servicing Storage Drives (CRU)

---

Storage Drives Hot-Plug Conditions	4-1
Storage Drive Failure and RAID	4-2
Storage Drive Locations and Numbering	4-2
Removing and Replacing a Storage Drive	4-3
Remove a Storage Drive	4-3
Install a Storage Drive	4-4
Removing and Replacing an NVMe Storage Drive Using Oracle Solaris	4-5
Unmount an NVMe Storage Drive	4-6
Remove an NVMe Storage Drive	4-6
Verify Removal of an NVMe Storage Drive	4-7
Install an NVMe Storage Drive	4-7
Power On an NVMe Storage Drive and Attach a Device Driver	4-7
Removing and Replacing an NVMe Storage Drive Using Oracle Linux	4-8
Unmount an NVMe Storage Drive	4-8
Remove an NVMe Storage Drive	4-9
Verify Removal of an NVMe Storage Drive	4-10
Install an NVMe Storage Drive	4-10
Power On an NVMe Storage Drive and Attach a Device Driver	4-11
Verify Operation of an NVMe Storage Drive	4-11
Removing and Replacing an NVMe Storage Drive Using Microsoft Windows Server	4-11
Remove an NVMe Storage Drive	4-11
Install an NVMe Storage Drive	4-12

## 5 Servicing Fan Modules (CRU)

---

Remove a Fan Module	5-1
Install a Fan Module	5-3

## 6 Servicing Power Supplies (CRU)

---

Power Supply Overview	6-1
Remove a Power Supply	6-2
Install a Power Supply	6-4

## 7 Servicing the DIMMs (CRU)

---

DIMM and Processor Physical Layout	7-2
DIMM Population Scenarios	7-3

DIMM Population Rules	7-3
Populating DIMMs for Optimal System Performance	7-4
Populating DIMMs in Single-Processor Systems for Optimal System Performance	7-4
Populating DIMMs in Dual-Processor Systems for Optimal System Performance	7-5
DIMM Operating Speeds	7-8
DIMM Rank Classification Labels	7-8
Inconsistencies Between DIMM Fault Indicators and the BIOS Isolation of Failed DIMMs	7-8
Using the Server Fault Remind Button	7-9
Identify and Remove a DIMM	7-9
Install a DIMM	7-11

## 8 Servicing PCIe Risers (CRU)

---

PCIe Riser Locations	8-1
Remove a PCIe Riser	8-2
Install a PCIe Riser	8-3

## 9 Servicing PCIe Cards (CRU)

---

PCIe Slot Locations	9-1
Remove a PCIe Card	9-2
Install a PCIe Card	9-3

## 10 Servicing the Internal M.2 Flash SSDs (CRU)

---

Remove an M.2 Mezzanine	10-1
Install an M.2 Mezzanine	10-3
Remove an M.2 Flash SSD	10-4
Install an M.2 Flash SSD	10-5

## 11 Servicing the Battery (CRU)

---

Remove the Battery	11-1
Install the Battery	11-2

## 12 Servicing Processors (FRU)

---

Identify and Remove a Processor	12-2
Install a Processor	12-8

<b>13</b>	<b>Servicing the Disk Backplane (FRU)</b>	
	Remove the Disk Backplane	13-1
	Install the Disk Backplane	13-3
<b>14</b>	<b>Servicing the Front LED Indicator Module (FRU)</b>	
	Remove the Front LED Indicator Module	14-1
	Install the Front LED Indicator Module	14-3
<b>15</b>	<b>Servicing the Temperature Sensor (FRU)</b>	
	Remove the Temperature Sensor	15-1
	Install the Temperature Sensor	15-4
<b>16</b>	<b>Servicing the NVMe Cables</b>	
	Remove NVMe Cables	16-1
	Install NVMe Cables	16-3
<b>17</b>	<b>Servicing Other Cables (FRU)</b>	
	Remove the FIM, Temperature Sensor, and Disk Backplane Data and Power Cables	17-1
	Install the FIM, Temperature Sensor, and Disk Backplane Data and Power Cables	17-4
<b>18</b>	<b>Servicing the OCP Network Interface Card (FRU)</b>	
	Remove the OCP Network Interface Card	18-1
	Install the OCP Network Interface Card	18-3
<b>19</b>	<b>Servicing the Motherboard Assembly (FRU)</b>	
	Remove the Motherboard	19-2
	Install the Motherboard	19-7
<b>20</b>	<b>Returning the Server to Operation</b>	
	Server Filler Panel Requirements	20-1
	Remove and Install Filler Panels	20-1
	Install the Server Top Cover	20-2
	Remove Antistatic Measures	20-3
	Reinstall the Server Into the Rack	20-3

Return the Server to the Normal Rack Position	20-4
Reconnect Data Cables and Power Cords	20-5
Power On the Server	20-6

## 21 Identifying the Server Ports

---

Gigabit Ethernet Ports	21-1
Network Management Port	21-1
Serial Management Port	21-2
USB Port	21-3

## 22 Setting Up BIOS Configuration Parameters

---

Manage the BIOS Configuration	22-1
Accessing the BIOS Setup Utility	22-1
BIOS Setup Utility Menus	22-1
BIOS Key Mappings	22-2
Access BIOS Setup Utility Menus	22-2
Navigate BIOS Setup Utility Menus	22-3
Using UEFI BIOS	22-4
Configuration Utilities for Add-In Cards	22-4
Configure and Manage BIOS Using Oracle ILOM	22-5
UEFI Secure Boot	22-5
Trusted Execution Technology	22-5
Common BIOS Setup Utility Tasks	22-5
Verify BIOS Factory Default Settings	22-6
Select a Temporary Boot Device	22-6
Configure TPM Support	22-7
Configure UEFI Driver Settings	22-8
Configure I/O Resource Allocation	22-8
Configure UEFI Secure Boot	22-9
Configure Trusted Execution Technology	22-10
Exit BIOS Setup Utility	22-10

## 23 BIOS Setup Utility Menu Options

---

Main Menu	23-1
Advanced Menu	23-2
Trusted Computing 2.0 Options	23-2
Serial Port Console Redirection	23-3
NVMe Configuration	23-4
Network Stack Configuration	23-4



PCI Subsystem Settings	23-4
SATA Configuration	23-5
Disk Freeze Lock	23-5
Processor Configuration	23-5
Intel Platform Configuration	23-5
Intel Socket Configuration	23-6
MD SSD Ports Configuration	23-7
USB Port	23-8
All CPU Information	23-8
RAM Disk Configuration	23-8
iSCSI Configuration	23-9
Driver Health	23-10
Intel VROC SATA Controller	23-11
Intel Virtual RAID on CPU	23-11
IO Menu	23-11
Internal Devices	23-11
Add-in Cards	23-11
PCIe Connector Configuration Settings	23-12
Security Menu	23-12
Boot Menu	23-13
Exit Menu	23-13

## 24 Monitoring Components and Identifying SNMP Messages

---

Monitoring Component Health and Faults Using Oracle ILOM	24-1
Monitoring System Components	24-1
System Chassis Components	24-2
Cooling Unit Components	24-4
Disk Backplane Components	24-4
Memory Device Components	24-5
Power Unit Components	24-6
Processor Components	24-6
System Motherboard Components	24-7
System Firmware Components	24-8
Disk Drive Components	24-8
Identifying SNMP Trap Messages	24-9
Environmental Events	24-10
Hard Disk Drive Events	24-11
Power Events	24-11
Fan Events	24-16
Memory Events	24-17

# Index

---

# Using This Documentation

- **Overview** – Describes how to troubleshoot and maintain the Oracle Server X9-2.
- **Audience** – Technicians, system administrators, authorized service providers, and trained hardware service personnel who have been instructed on the hazards within the equipment and are qualified to remove and replace hardware.
- **Required knowledge** – Advanced experience troubleshooting and replacing hardware.

Copyright© 1994, 2022, Oracle et/ou ses affiliés.

## Product Documentation Library

Documentation and resources for this product and related products are available at [Oracle Server X9-2 Documentation](#).

## Feedback

Provide feedback about this documentation at <http://www.oracle.com/goto/docfeedback> .

# 1

## About the Oracle Server X9-2

These sections describe the controls, connectors, status indicators, system components, and replaceable components of the server:

- [Product Description](#)
- [Front and Back Panel Components](#)
- [About System Components](#)



### Note:

Always update the server with the latest firmware, drivers, and other hardware-related software by downloading the latest software release package when you first receive the server, and for every new software release. For information about the software release packages and how to download the software, refer to *Getting Firmware and Software in Oracle Servers X9-2 and X9-2L Installation Guide at Oracle Server X9-2 Documentation*.

## Product Description

The Oracle Server X9-2 is an enterprise-class, one rack unit (1U) server. It supports the following components:

- Up to two Intel processors with the following capabilities are supported:
  - Intel Xeon Platinum, 32-core, 2.6 GHz, 250 W processors
  - Intel Xeon Gold, 24-core, 2.0 GHz, 165 W processors
  - Intel Xeon Gold, 18-core, 3.0 GHz, 205 W processors
  - Intel Xeon Silver, 16-core, 2.3 GHz, 135 W processors
- Up to sixteen DDR4 DIMMs per processor for a maximum of thirty-two 32-GB and 64-GB RDIMMs with speeds up to 3200 MT/sec are supported in dual-processor systems. Total supported memory is 2 TB.
- Up to three x16 PCIe Gen4 slots in dual-processor systems. PCIe slot 1 is nonfunctional in single-processor systems.
- Storage drive configurations can include the following:
  - Up to four 2-5-inch hot-pluggable NVM-Express (NVMe) solid-state disk drives (SSDs)
  - Two internal M.2 Gen3 SATA or PCIe Gen3 NVMe flash SSDs
- Two hot-pluggable, redundant 1200W (or 1400W) power supplies.
- Four hot-swappable fan modules, each containing two 40x56 mm counter-rotating fans.

- An on-board Oracle Integrated Lights Out Manager (Oracle ILOM) service processor (SP) based on the ASPEED Pilot 4 chip.

## Front and Back Panel Components

The following sections describe the controls, indicators, connectors, and drives located on the front and back panels.

- [Front Panel Controls and Indicators](#)
- [Back Panel Components and Cable Connections](#)

### Related Topics

- [About System Components](#)
- [Illustrated Parts Breakdown](#)

## Front Panel Controls and Indicators

The following figure shows the controls, status indicators (LEDs), connectors, and drives on the front panel of the Oracle Server X9-2.

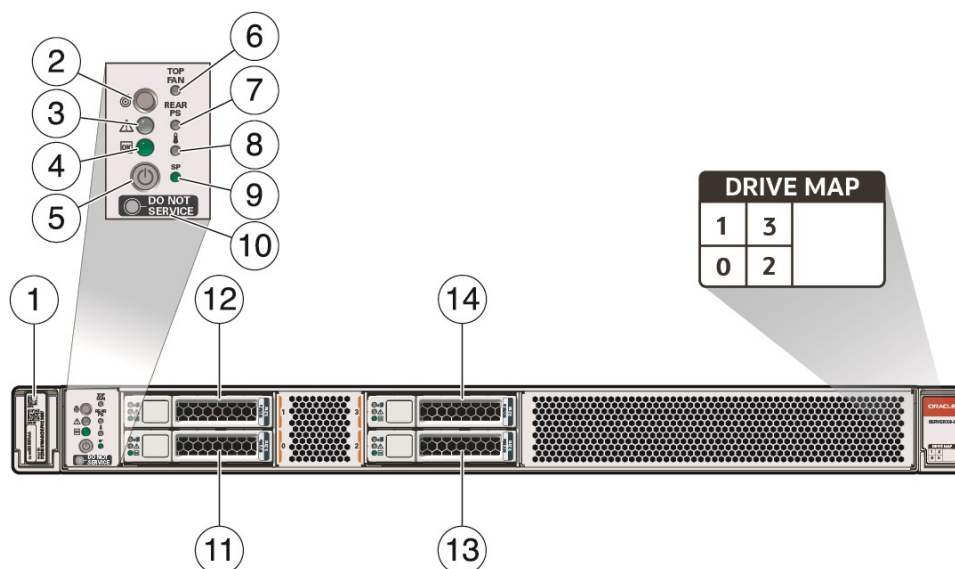

Callout	Description
1	Product Serial Number (PSN) label and Radio Frequency Identification (RFID) tag
2	Locate Button/LED: white
3	Fault-Service Required LED: amber
4	System OK LED: green
5	On/Standby button
6	Fault-Service Required LED: Top: Fan Module (amber)

Callout	Description
7	Fault-Service Required LED: Rear: Power Supply (amber)
8	Fault-Service Required LED: Overtemp Icon: System Over Temperature Warning (amber)
9	SP OK LED: green
10	DO NOT SERVICE LED: white
11	Storage drive 0 NVMe
12	Storage drive 1 NVMe
13	Storage drive 2 NVMe
14	Storage drive 3 NVMe

### Related Topics

- [Back Panel Components and Cable Connections](#)
- [About System Components](#)

## Back Panel Components and Cable Connections

The following figure shows the Oracle Server X9-2 back panel and the location of power supplies, status indicators (LEDs), connectors, and PCIe slots.

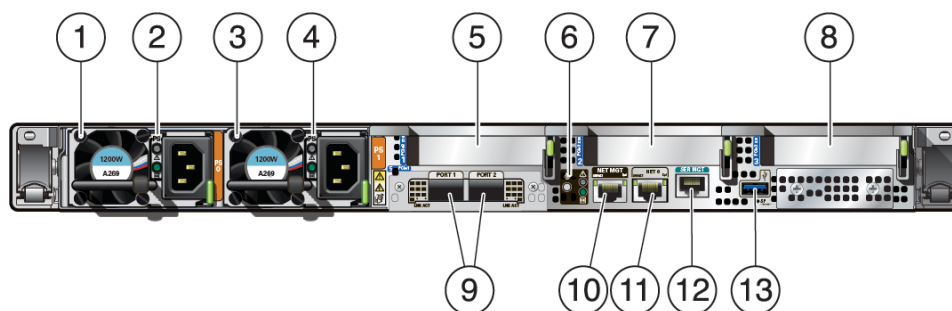

Callout	Description
1	Power Supply (PS) 0
2	Power Supply (PS) 0 status indicators: Fault-Service Required LED: amber; AC OK LED: green
3	Power Supply (PS) 1
4	Power Supply (PS) 1 status indicators: Fault-Service Required LED: amber; AC OK LED: green
5	PCIe card slot 1 (Nonfunctional in single-processor systems)
6	System status indicators: Locate Button/LED: white; Fault-Service Required LED: amber; System OK LED: green
7	PCIe card slot 2
8	PCIe card slot 3

Callout	Description
9	(Optional) 10/25/50/100/200 Gbs Open Compute Project (OCP) Version 3.0 (V3) Network Interface Card (NIC) with two QSFP ports (PORT 1 and PORT 2)
10	Oracle Integrated Lights Out Manager (ILOM) service processor (SP) network management (NET MGT) RJ-45 100/1000BASE-T port
11	Network (NET) 100/1000BASE-T RJ-45 Gigabit Ethernet (GbE) port: NET 0
12	Serial management (SER MGT) RJ-45 serial port
13	USB 3.0 connector



**Note:**

For more information on back panel components and connections, see [Back Panel Connector Locations](#). See also [Back Panel Pinhole Switch](#).

**Related Topics**

- [Front Panel Controls and Indicators](#)
- [About System Components](#)

## About System Components

These sections describe the components of the server:

- [Illustrated Parts Breakdown](#)
- [Customer-Replaceable Units](#)
- [Field-Replaceable Units](#)

## Illustrated Parts Breakdown

The following figure identifies the major components of the server.

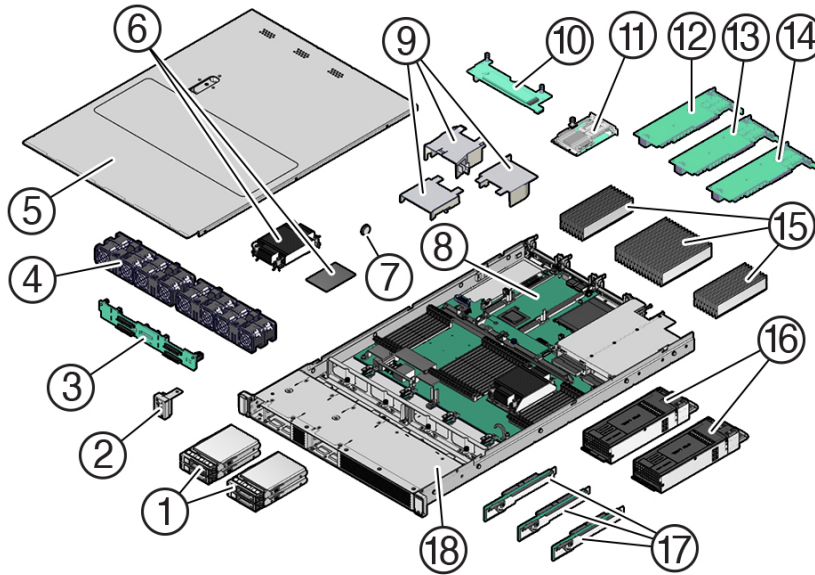

Callout	Description
1	Four storage drives
2	Front LED indicator module
3	Disk backplane
4	Fan modules
5	Top cover
6	Processors and heatsinks (Single-processor systems contain only a single processor in socket P0; socket P1 contains a cover to protect processor socket pins.)
7	Battery
8	Motherboard
9	Air baffles (P0, P1, and P1 exhaust)
10	Internal M.2 riser mezzanine and M.2 flash SSDs
11	(Optional) OCP V3 NIC
12	(Optional) PCIe card in slot 3
13	(Optional) PCIe card in slot 2
14	(Optional) PCIe card in slot 1 <b>Note:</b> PCIe slot 1 is nonfunctional in single-processor systems.
15	DIMMs (Sixteen DIMMs are supported in single-processor systems and the DIMMs must be installed in P0 DIMM sockets.)
16	Power supplies
17	PCIe risers (3)
18	Server chassis



## Customer-Replaceable Units

The following table lists the customer-replaceable units (CRUs) in the server and directs you to the replacement instructions.

CRU (Service Level)	Description	Replacement Instructions
Battery (Cold service)	Lithium coin-cell battery that powers the CMOS BIOS and real-time clock.	<a href="#">Servicing the Battery (CRU)</a>
DIMMs (Cold service)	Add or replace memory modules in the system.	<a href="#">Servicing the DIMMs (CRU)</a>
Storage drives (Hot service)	Supports NVMe SSDs.	<a href="#">Servicing Storage Drives (CRU)</a>
Internal M.2 flash SSDs (Cold service)	Supports up to two internal M.2 Gen3 SATA or PCIe Gen3 NVMe flash SSDs.	<a href="#">Servicing the Internal M.2 Flash SSDs (CRU)</a>
Fan modules (Hot service)	Four fan modules for cooling the motherboard assembly and installed components.	<a href="#">Servicing Fan Modules (CRU)</a>
PCIe cards (Cold service)	Optional add-on PCIe cards that can expand the functionality of the server.	<a href="#">Servicing PCIe Cards (CRU)</a>
PCIe risers (Cold service)	Houses and connects the PCIe cards.	<a href="#">Servicing PCIe Risers (CRU)</a>
Power supplies (Hot service)	Two fully redundant AC power supplies.	<a href="#">Servicing Power Supplies (CRU)</a>

### Related Topics

- [Field-Replaceable Units](#)
- [Illustrated Parts Breakdown](#)

## Field-Replaceable Units

The following table lists the field-replaceable units (FRUs) in the server and directs you to the replacement instructions.

FRU (Service Level)	Description	Replacement Instructions
Processor and heatsink (Cold service)	Processor that carries out the instructions of the system.	<a href="#">Servicing Processors (FRU)</a>
Disk backplane (Cold service)	Serves as the interface between storage drives and the PCIe NVMe signals from the motherboard.	<a href="#">Servicing the Disk Backplane (FRU)</a>
Front LED indicator module (Cold service)	Contains the push-button circuitry and LEDs that are displayed on the front panel.	<a href="#">Servicing the Front LED Indicator Module (FRU)</a>
Temperature sensor (Cold service)	Provides temperature information for the system.	<a href="#">Servicing the Temperature Sensor (FRU)</a>

FRU (Service Level)	Description	Replacement Instructions
OCP V3 NIC (Cold service)	(Optional) Provides two Gigabit Ethernet QSFP ports (PORT 1 and PORT 2) on the server rear panel.	<a href="#">Servicing the OCP Network Interface Card (FRU)</a>
Motherboard assembly (Cold service)	Provides connectors for the fans, DIMMs, processors, PCIe risers, and power supplies.	<a href="#">Servicing the Motherboard Assembly (FRU)</a>
NVMe cables (Cold service)	Provide signals between the disk backplane and the motherboard NVMe connectors.	<a href="#">Servicing the NVMe Cables</a>

### Related Topics

- [Customer-Replaceable Units](#)
- [Illustrated Parts Breakdown](#)

# 2

## Troubleshooting and Diagnostics

This section includes information about troubleshooting hardware component faults for Oracle Server X9-2. It contains the following topics:

- [Troubleshooting Server Component Hardware Faults](#)
- [Troubleshooting With Diagnostic Tools](#)
- [Attaching Devices to the Server](#)
- [Getting Help](#)
- [Auto Service Requests](#)

For more information about server troubleshooting and diagnostics, refer to the *Oracle x86 Servers Diagnostics and Troubleshooting Guide* at [Oracle x86 Servers Administration, Diagnostics, and Applications Documentation](#).

### Troubleshooting Server Component Hardware Faults

This section contains maintenance-related information and procedures that you can use to troubleshoot and repair server hardware issues. The following topics are covered.

- [Troubleshooting Server Hardware Faults](#)
- [Troubleshooting and Diagnostic Information](#)
- [Troubleshooting Using the Server Front and Back Panel Status Indicators](#)
- [Troubleshooting System Cooling Issues](#)
- [Troubleshooting Power Issues](#)

### Troubleshooting Server Hardware Faults

When a server hardware fault event occurs, the system lights the Fault-Service Required LED and captures the event in the Oracle ILOM event log. If you set up notifications through Oracle ILOM, you also receive an alert through the notification method you choose. When you become aware of a hardware fault, address it immediately.

To investigate a hardware fault, see the following:

- [Basic Troubleshooting Process](#)
- [Troubleshoot Hardware Faults Using the Oracle ILOM Web Interface](#)

### Basic Troubleshooting Process

Use the following process to address a hardware fault (for the step-by-step procedure, see [Troubleshoot Hardware Faults Using the Oracle ILOM Web Interface](#)).

1. **Identify the server subsystem containing the fault.**

You can use Oracle ILOM to identify the failed component.

2. **Review the** *Oracle Server X9-2 Product Notes* at [Oracle Server X9-2 Documentation](#).

The product notes contain up-to-date information about the server, including hardware-related issues.

3. **Prepare the server for service using Oracle ILOM.**

If you determined that the hardware fault requires service (physical access to the server), use Oracle ILOM to take the server offline, activate the Locate button/LED, and if necessary, power off the server.

4. **Prepare the service work space.**

Before servicing the server, prepare the work space, ensuring Electrostatic Discharge Safety (ESD) protection for the server and components.

See [Preparing for Service](#).

5. **Service the components.**

To service the components, see the removal, installation, and replacement procedures in this document.

 **Note:**

A component designated as a field-replaceable unit (FRU) must be replaced by Oracle Service personnel. Contact Oracle Service.

6. **Clear the fault in Oracle ILOM.**

Depending on the component, you might need to clear the fault in Oracle ILOM. Generally, components that have a FRU ID, clear the fault automatically.

## Troubleshoot Hardware Faults Using the Oracle ILOM Web Interface

 **Note:**

The screens shown in this procedure might differ from those for your server.

This procedure uses the basic troubleshooting steps described in [Basic Troubleshooting Process](#).

Use this procedure to troubleshoot hardware faults using the Oracle ILOM web interface and, if necessary, prepare the server for service.

 **Note:**

This procedure provides one basic approach to troubleshooting hardware faults. It uses the Oracle ILOM web interface. However, the procedure can be performed using the Oracle ILOM command-line interface (CLI). For more information about the Oracle ILOM web interface and CLI, refer to the Oracle ILOM documentation.

1. Log in to the server SP Oracle ILOM web interface.

Open a browser and direct it using the IP address of the server SP. On the Login screen, enter a user name (with administrator privileges) and password. The Summary Information page appears.

The Status section of the Summary Information page provides information about the server subsystems, including:

- Processors
- Memory
- Power
- Cooling
- Storage
- Networking
- PCI Devices
- Firmware

2. In the Status section of the Oracle ILOM Summary Information page, identify the server subsystem that requires service.

For example, if a hardware component in the subsystem is in a fault state, the Status column notes the status as Service Required.

3. To identify the faulty component, click the component in the Status section.

The Oracle ILOM page showing the faulty component appears.

4. To get more information, click the Open Problems link.

The Open Problems page provides detailed information, such as the time the event occurred, the component and subsystem name, and a description of the issue. It also includes a link to an Oracle Knowledge Base article.

 **Tip:**

The System Log provides a chronological list of all the system events and faults that occurred since the log was last reset and includes additional information, such as severity levels and error counts. The System Log also includes information on the devices not reported in the Status section. To access the System Log, in the left panel, click System Log.

5. Before going to the server, review the Oracle Server X9-2 Product Notes for information related to the issue or the component.

The Product Notes contain up-to-date information about the server, including hardware-related issues. To access the Product Notes, go to [Oracle Server X9-2 Documentation](#).

6. To prepare the server for service, see Preparing for Service.

After servicing the component, you might need to clear the fault in Oracle ILOM. For more information, refer to the service procedure for the component.

7. Service the component.

## Troubleshooting and Diagnostic Information

The following list displays diagnostic and troubleshooting-related procedures and references that can assist you with resolving server issues.

- [Oracle x86 Servers Diagnostics and Troubleshooting Guide at Oracle x86 Servers Administration, Diagnostics, and Applications Documentation](#)
- [Oracle X9 Series Servers Administration Guide at Oracle x86 Servers Administration, Diagnostics, and Applications Documentation](#)
- [Troubleshooting Using the Server Front and Back Panel Status Indicators](#)
- [Managing Server Hardware Faults Through the Oracle ILOM Fault Management Shell](#)

## Troubleshooting Using the Server Front and Back Panel Status Indicators

These sections describe the status indicators (LEDs) located on the front and back of the server, including those found on components and ports. This section includes the following topics:

- [Server Boot Process and Normal Operating State Indicators](#)
- [Server System-Level Status Indicators](#)
- [Server Fan Status Indicators](#)
- [Storage Drive Status Indicators](#)
- [Power Supply Status Indicators](#)
- [Network Management Port Status Indicators](#)
- [Ethernet Ports Status Indicators](#)
- [Motherboard Status Indicators](#)

### Related Topics

- [Front Panel Controls and Indicators](#)
- [Back Panel Components and Cable Connections](#)

## Server Boot Process and Normal Operating State Indicators

A normal server boot process involves two indicators, the service processor SP OK LED indicator and the System OK LED indicator.

When AC power is connected to the server, the server boots into standby power mode:

1. The SP OK LED blinks slowly (0.5 seconds on, 0.5 seconds off) while the SP is starting, and the System OK LED remains off until the SP is ready.
2. After a few minutes, the main System OK LED slowly flashes the standby blink pattern (0.1 seconds on, 2.9 seconds off), indicating that the SP (and Oracle ILOM) is ready for use. In Standby power mode, the server is not initialized or fully powered on at this point.

When powering on the server (either by the On/Standby button or Oracle ILOM), the server boots to full power mode:



1. The System OK LED blinks slowly (0.5 seconds on, 0.5 seconds off), and the SP OK LED remains lit (no blinking).
2. When the server successfully boots, the System OK LED remains lit. When the System OK LED and the SP OK LED indicators remain lit, the server is in Main power mode.

 **Note:**

The green System OK LED indicator and the green SP OK indicator remain lit (no blinking) when the server is in a normal operating state.



## Server System-Level Status Indicators

There are seven system-level status indicators (LEDs), some of which are located on both the server front panel and the back panel. For the location of the status indicators, see [Front and Back Panel Components](#). The following table describes these indicators.

Status Indicator Name	Icon	Color	State and Meaning
Locate Button/LED		White	Indicates the location of the server. <ul style="list-style-type: none"> <li>• OFF – Server is operating normally.</li> <li>• FAST BLINK (250 ms) – Use Oracle ILOM to activate this LED indicator to enable you to locate a particular system quickly and easily.</li> <li>• Pressing the Locate button toggles the LED indicator fast blink on or off.</li> </ul>
Fault-Service Required		Amber	Indicates the fault state of the server. <ul style="list-style-type: none"> <li>• OFF – The server is operating normally.</li> <li>• STEADY ON – A fault is present on the server. This LED indicator lights whenever a fault indicator lights for a replaceable component on the server.</li> </ul> <p><b>Note:</b> When this LED indicator is lit, a system console message might appear that includes a recommended service action.</p>

Status Indicator Name	Icon	Color	State and Meaning
System OK		Green	<p>Indicates the operational state of the chassis.</p> <ul style="list-style-type: none"> <li>• OFF – AC power is not present or the Oracle ILOM boot is not complete.</li> <li>• STANDBY BLINK (on for 100 ms, off for 2900 ms) – Standby power is on, but the chassis power is off and the Oracle ILOM SP is running.</li> <li>• SLOW BLINK (1000 ms) – Startup sequence was initiated on the host. This pattern begins soon after you power on the server. This status indicates either: power-on self-test (POST) code checkpoint tests are running on the server host system, or the host is transitioning from the powered-on state to the standby state on shutdown.</li> <li>• STEADY ON – The server is powered on, and all host POST code checkpoint tests are complete. The server is in one of the following states: the server host is booting the operating system (OS), or the server host is running the OS.</li> </ul>
SP OK	<b>SP</b>	Green	<p>Indicates the state of the service processor.</p> <ul style="list-style-type: none"> <li>• OFF – Service processor (SP) is not running.</li> <li>• SLOW BLINK – SP is booting.</li> <li>• STEADY ON – SP is fully operational.</li> </ul>
Top Fan	<b>TOP FAN</b>	Amber	<p>Indicates that one or more of the internal fan modules failed.</p> <ul style="list-style-type: none"> <li>• OFF – Indicates steady state; no service is required.</li> <li>• STEADY ON – Indicates service required.</li> </ul>
Back Power Supply Fault	<b>REAR PS</b>	Amber	<p>Indicates that one of the server power supplies failed.</p> <ul style="list-style-type: none"> <li>• OFF – Indicates steady state; no service is required.</li> <li>• STEADY ON – Indicates service required; service the power supply.</li> </ul>



Status Indicator Name	Icon	Color	State and Meaning
System Over Temperature Warning		Amber	<p>Indicates a warning for an overtemperature condition.</p> <ul style="list-style-type: none"> <li>• OFF – Normal operation; no service is required.</li> <li>• STEADY ON – The system is experiencing an overtemperature warning condition.</li> </ul> <p><b>Note:</b> This is a warning indication, not a fatal overtemperature. Failure to correct this might result in the system overheating and shutting down unexpectedly.</p>
DO NOT SERVICE		White	<p>Indicates that the system is not ready to service.</p> <ul style="list-style-type: none"> <li>• OFF – Normal operation.</li> <li>• STEADY ON – The system is not ready for service.</li> </ul> <p><b>Note:</b> The DO NOT SERVICE indicator is application specific. This indicator is only illuminated on demand by the Host application.</p>



## Server Fan Status Indicators

Each fan module has one status indicator (LED). The LEDs are located on the fan modules, and are visible when the server top cover is removed.

Status Indicator Name	Icon	Color	State and Meaning
Fan Status		Amber	<ul style="list-style-type: none"> <li>• Off – The fan module is correctly installed and operating within specification.</li> <li>• Amber – The fan module is faulty. The front TOP FAN LED and the front and back panel Fault-Service Required LEDs are also lit if the system detects a fan module fault.</li> </ul>

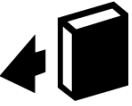

## Storage Drive Status Indicators

There are three status indicators (LEDs) on each drive.

Status Indicator Name	Icon	Color	State and Meaning
OK/Activity		Green	<ul style="list-style-type: none"> <li>• OFF – Power is off or installed drive is not recognized by the system.</li> <li>• STEADY ON – The drive is engaged and is receiving power.</li> <li>• RANDOM BLINK – There is disk activity. Status indicator LED blinks on and off to indicate activity.</li> </ul>
Fault-Service Required		Amber	<ul style="list-style-type: none"> <li>• OFF – The storage drive is operating normally.</li> <li>• STEADY ON – The system detected a fault with the storage drive.</li> </ul>
OK to Remove		Blue	<ul style="list-style-type: none"> <li>• STEADY ON – The storage drive can be removed safely during a hot-plug operation.</li> <li>• OFF – The storage drive is not prepared for removal.</li> </ul>

## Power Supply Status Indicators

There are two status indicators (LEDs) on each power supply. These indicators are visible from the back of the server.

Status Indicator Name	Icon	Color	State and Meaning
AC OK/ DC OK		Green	<ul style="list-style-type: none"> <li>• OFF – No AC power is present.</li> <li>• SLOW BLINK – Normal operation. Input power is within specification. DC output voltage is not enabled.</li> <li>• STEADY ON – Normal operation. Input AC power and DC output voltage are within specification.</li> </ul>
Fault-Service Required		Amber	<ul style="list-style-type: none"> <li>• OFF – Normal operation. No service action is required.</li> <li>• STEADY ON – The power supply (PS) detected a PS fan failure, PS overtemperature, PS over current, or PS over or under voltage.</li> </ul>

## Network Management Port Status Indicators

The server has one 100/1000BASE-T Ethernet management domain interface, labeled NET MGT. There are two status indicators (LEDs) on this port. These indicators are visible from the back of the server.

Status Indicator Name	Location	Color	State and Meaning
Activity	Top left	Green	<ul style="list-style-type: none"> <li>ON – Link up.</li> <li>OFF – No link or down link.</li> <li>BLINKING – Packet activity.</li> </ul>
Link speed	Top right	Green	<ul style="list-style-type: none"> <li>ON – 100BASE-T link.</li> <li>OFF – 10BASE-T link.</li> </ul>

## Ethernet Ports Status Indicators

The server has three Gigabit Ethernet (GbE) ports:

- One 100/1000BASE-T RJ-45 GbE port, labeled NET 0
- (Optional) Two 10/25/50/100/200 GbE quad small form-factor pluggable (QSFP) ports, labeled PORT 1 and PORT 2

There are two status indicators (LEDs) on each port. These indicators are visible from the rear of the server.

Status Indicator Name	Location	Color	State and Meaning
<b>RJ-45 1GbE Port (NET 0)</b>			
Activity	Top left	Green	<ul style="list-style-type: none"> <li>ON – Link up.</li> <li>OFF – No activity.</li> <li>BLINKING – Packet activity.</li> </ul>
Link speed	Top right	Green	<ul style="list-style-type: none"> <li>OFF – 100BASE-T link (if link up).</li> <li>Green ON – 1000BASE-T link.</li> </ul>
<b>QSFP 10/25/50/100/200 GbE Ports (PORT 1 and PORT 2)</b>			
Activity	Bottom (Right)	Green	<ul style="list-style-type: none"> <li>OFF – No activity.</li> <li>BLINKING – Packet activity.</li> </ul>
Link Speed	Bottom (Left)	Bi-colored: Amber/ Green	<ul style="list-style-type: none"> <li>OFF – No activity.</li> <li>Amber ON – 10GbE link.</li> <li>Green ON – 25GbE link.</li> </ul>

## Motherboard Status Indicators

The motherboard contains the following status indicators (LEDs).

Status Indicator	Description
DIMM Fault Status Indicators	<ul style="list-style-type: none"> <li>• Each of the 32 DIMM slots on the motherboard has an amber fault status indicator (LED) associated with it.</li> <li>• If Oracle ILOM determines that a DIMM is faulty, pressing the Fault Remind button on the motherboard I/O card signals the service processor to light the fault LED associated with the failed DIMM.</li> <li>• For more information on DIMM fault status indicators and the location of the Fault Remind button, see <a href="#">Servicing the DIMMs (CRU)</a>.</li> </ul>

Status Indicator	Description
Processor Fault Status Indicators	<ul style="list-style-type: none"> <li>The motherboard includes a fault status indicator (LED) adjacent to each of the two processor sockets.</li> <li>These LEDs indicate when a processor fails.</li> <li>Pressing the Fault Remind button on the motherboard I/O card signals the service processor to light the fault status indicators associated with the failed processors.</li> <li>For more information on processor fault status indicators and the location of the Fault Remind button, see <a href="#">Servicing Processors (FRU)</a>.</li> </ul>
Fault Remind Status Indicator	<ul style="list-style-type: none"> <li>This status indicator (LED) is located next to the Fault Remind button and is powered from the super capacitor that powers the fault LEDs on the motherboard.</li> <li>This LED lights to indicate that the fault remind circuitry is working properly in cases where no components failed and, as a result, none of the component fault LEDs illuminate.</li> <li>For more information on the fault remind status indicator and the location of the Fault Remind button, see <a href="#">Using the Server Fault Remind Button</a>.</li> </ul>
STBY PWRGD Status Indicator	<ul style="list-style-type: none"> <li>This green status indicator (LED) is labeled STBY PWRGD and is located on the motherboard near the back of the server.</li> <li>This LED lights to inform a service technician that the motherboard is receiving Standby power from at least one of the power supplies.</li> <li>This LED is provided to help prevent service actions on the server internal components while the AC power cords are installed and power is being supplied to the server.</li> </ul>

## Troubleshooting System Cooling Issues

Maintaining the proper internal operating temperature of the server is crucial to the health of the server. To prevent server shutdown and damage to components, address over temperature and hardware-related issues as soon as they occur. If your server has a temperature-related fault, use the information in the following table to troubleshoot the issue.

Cooling Issue	Description	Action	Prevention
External Ambient Temperature Too High	The server fans pull cool air into the server from its external environment. If the ambient temperature is too high, the internal temperature of the server and its components increases. This can cause poor performance and component failure.	Verify the ambient temperature of the server space against the environmental specifications for the server. If the temperature is not within the required operating range, remedy the situation immediately.	Periodically verify the ambient temperature of the server space to ensure that it is within the required range, especially if you made any changes to the server space (for example, added additional servers). The temperature must be consistent and stable.

<b>Cooling Issue</b>	<b>Description</b>	<b>Action</b>	<b>Prevention</b>
Airflow Blockage	The server cooling system uses fans to pull cool air in from the server front intake vents and exhaust warm air out the server back panel vents. If the front or back vents are blocked, the airflow through the server is disrupted and the cooling system fails to function properly causing the server internal temperature to rise.	Inspect the server front and back panel vents for blockage from dust or debris. Additionally, inspect the server interior for improperly installed components or cables that can block the flow of air through the server.	Periodically inspect and clean the server vents using an ESD certified vacuum cleaner. Ensure that all components, such as cards, cables, fans, air baffles and dividers are properly installed. Never operate the server without the top cover installed.
Cooling Areas Compromised	The air baffle, component filler panels, and server top cover maintain and direct the flow of cool air through the server. These server components must be in place for the server to function as a sealed system. If these components are not installed correctly, the airflow inside the server can become chaotic and non-directional, which can cause server components to overheat and fail.	Inspect the server interior to ensure that the air baffle is properly installed. Ensure that all external-facing slots (storage drive, PCIe) are occupied with either a component or a component filler panel. Ensure that the server top cover is in place and sits flat and snug on top of the server.	When servicing the server, ensure that the air baffle is installed correctly and that the server has no unoccupied external-facing slots. Never operate the server without the top cover installed.

Cooling Issue	Description	Action	Prevention
Hardware Component Failure	<ul style="list-style-type: none"> <li>Components, such as power supplies and fan modules, are an integral part of the server cooling system. When one of these components fails, the server internal temperature can rise. This rise in temperature can cause other components to enter into an over-temperature state. Additionally, some components, such as processors, might overheat when they are failing, which can also generate an over-temperature event.</li> <li>To reduce the risk related to component failure, power supplies and fan modules are installed in pairs to provide redundancy. Redundancy ensures that if one component in the pair fails, the other functioning component can continue to maintain the subsystem.</li> </ul>	Investigate the cause of the overtemperature event, and replace failed components <i>immediately</i> . For hardware troubleshooting information, see <a href="#">Troubleshooting Server Hardware Faults</a> .	Component redundancy is provided to allow for component failure in critical subsystems, such as the cooling subsystem. However, once a component in a redundant system fails, the redundancy no longer exists, and the risk for server shutdown and component failures increases. Therefore, it is important to maintain redundant systems and replace failed components <i>immediately</i> .

## Troubleshooting Power Issues

If your server does not power on, use the information in the following table to troubleshoot the issue.

Power Issue	Description	Action	Prevention
AC Power Connection	The AC power cords are the direct connection between the server power supplies and the power sources. The server power supplies need separate stable AC circuits. Insufficient voltage levels or fluctuations in power can cause server power problems. The power supplies are designed to operate at a particular voltage and within an acceptable range of voltage fluctuations (refer to <i>Electrical Requirements in Oracle Servers X9-2 and X9-2L Installation Guide</i> ).	Verify that both AC power cords are connected to the server. Verify that the correct power is present at the outlets and monitor the power to verify that it is within the acceptable range. You can verify proper connection and operation by verifying the power supply (PS) indicator panels, which are located at the back of the server on the power supplies. Lit green AC OK indicators show a properly functioning power supply. An amber AC OK indicator indicates that the AC power to the power supply is insufficient.	Use the AC power cord Velcro retaining clips and position the cords to minimize the risk of accidental disconnection. Ensure that the AC circuits that supply power to the server are stable and not overburdened.
Power Supplies (PSUs)	The server power supply units (PSUs) provide the necessary server voltages from the AC power outlets. If the power supplies are inoperable, unplugged, or disengaged from the internal connectors, the server cannot power on.  <b>Note:</b> Use the Velcro straps on the back of the server to secure the power cord connectors to the back of the power supplies. The Velcro retaining straps minimize the risk of accidental disconnection.	Verify that the AC cables are connected to both power supplies. Verify that the power supplies are operational (the PSU indicator panel must have a lit green AC OK indicator). Ensure that the power supply is properly installed. A power supply that is not fully engaged with its internal connector does not have power applied and does not have a lit green AC OK indicator.	When a power supply fails, replace it immediately. To ensure redundancy, the server has two power supplies. This redundant configuration prevents server downtime, or an unexpected shutdown, due to a failed power supply. The redundancy allows the server to continue to operate if one of the power supplies fails. However, when a server is being powered by a single power supply, the redundancy no longer exists, and the risk for downtime or an unexpected shutdown increases. When installing a power supply, ensure that it is fully seated and engaged with its connector inside the drive bay. A properly installed power supply has a lit green AC OK indicator.

Power Issue	Description	Action	Prevention
Top Cover	The server top cover maintains the air pressures inside the server, prevents accidental exposure to hazardous voltages, and protects internal components from physical and environmental damage.	Do not operate the server without the top cover installed unless you are hot-plugging a fan module, and then ensure that you complete the operation and replace the cover within 20 seconds. For instructions for properly replacing fan modules, see <a href="#">Servicing Fan Modules (CRU)</a> . For instructions for installing the server top cover, see <a href="#">Install the Server Top Cover</a> .	Be careful to avoid bending or otherwise warping the top cover.

## Managing Server Hardware Faults Through the Oracle ILOM Fault Management Shell

The Oracle ILOM Fault Management Shell enables you to view and manage fault activity on managed servers and other types of devices.

For more information about how to use the Oracle ILOM Fault Management Shell, refer to the *Oracle ILOM User's Guide for System Monitoring and Diagnostics Firmware Release 5.0.x* at [Oracle Integrated Lights Out Manager \(ILOM\) 5.0 Documentation](#).

## Troubleshooting With Diagnostic Tools

The server and its accompanying software and firmware contain diagnostic tools and features that can help you isolate component problems, monitor the status of a functioning system, and exercise one or more subsystem to disclose more subtle or intermittent hardware-related problems.

Each diagnostic tool has its own specific strength and application. Review the tools listed in this section and determine which tool might be best to use for your situation. After you determine the tool to use, you can access it locally, while at the server, or remotely.

- [Diagnostic Tools](#)
- [Diagnostic Tool Documentation](#)

## Diagnostic Tools

The selection of diagnostic tools available for your server range in complexity from a comprehensive validation test suite (Oracle VTS) to a chronological event log (Oracle ILOM event Log). The selection of diagnostic tools also includes standalone software packages, firmware-based tests, and hardware-based LED indicators.

The following table summarizes the diagnostic tools that you can use when troubleshooting or monitoring your server.



Diagnostic Tool	Type	What It Does	Accessibility	Remote Capability
Oracle ILOM	SP firmware	Monitors environmental condition and component functionality sensors, generates alerts, performs fault isolation, and provides remote access.	Can function on either Standby power mode or Main power mode and is not OS dependent.	Designed for remote and local access.
Hardware-based LED indicators	Hardware and SP firmware	Indicates status of overall system and particular components.	Available when system power is available.	Local, but sensor and indicators are accessible from Oracle ILOM web interface or command-line interface (CLI).
Power-On Self-Test (POST)	Host firmware	Tests core components of system: CPUs, memory, and motherboard I/O bridge integrated circuits.	Runs on startup. Available when the operating system is not running.	Local, but can be accessed through Oracle ILOM Remote System Console Plus.
UEFI Diagnostics	SP firmware	UEFI diagnostics can test and detect problems on all processors, memory, disk drives, and network ports.	You can use either the Oracle ILOM web interface or the command-line interface (CLI) to run UEFI diagnostics.	Remote access through Oracle ILOM Remote System Console Plus.
HWdiag	SP firmware	The HWdiag utility checks the status of a system and its components. You run the HWdiag utility within the Oracle ILOM Diag shell.	Can function on Standby power and when operating system is not running.	Local, but remote serial access is possible if the SP serial port is connected to a network-accessible terminal server.
Oracle Solaris commands	Operating system software	Displays various kinds of system information.	Requires operating system.	Local, and over network.
Oracle Linux commands	Operating system software	Displays various kinds of system information.	Requires operating system.	Local, and over network.
Oracle VTS	Diagnostic tool standalone software	Exercises and stresses the system, running tests in parallel.	Requires the Solaris operating system. Install Oracle VTS software separately.	View and control over network.

## Diagnostic Tool Documentation

The following table identifies where you can find more information about diagnostic tools.

Diagnostic Tool	Documentation	Location
Oracle ILOM	Oracle Integrated Lights Out Manager 5.0 Documentation Library	<a href="#">Oracle Integrated Lights Out Manager (ILOM) 5.0 Documentation</a>
UEFI Diagnostics or HWdiag	<i>Oracle x86 Servers Diagnostics and Troubleshooting Guide</i>	<a href="#">Oracle x86 Servers Administration, Diagnostics, and Applications Documentation</a>
System indicators and sensors	This document	<a href="#">Troubleshooting Using the Server Front and Back Panel Status Indicators</a>
Oracle VTS	Oracle VTS software and documentation	<a href="#">Oracle VTS 8.2.0 Documentation Library</a>

## Attaching Devices to the Server

The following sections contain procedural information for attaching devices to the server so you can access diagnostic tools when troubleshooting and servicing the server:

- [Attach Devices to the Server](#)
- [Back Panel Connector Locations](#)
- [Configuring Serial Port Sharing](#)
- [Server Operating System Names for the NVMe Storage Drives](#)
- [Ethernet Device Naming](#)
- [MAC Address Mapping to Ethernet Ports](#)
- [Back Panel Pinhole Switch](#)

### Attach Devices to the Server

This procedure explains how to connect devices to the server (remotely and locally), so that you can interact with the service processor (SP) and the server console.

1. Connect an Ethernet cable to the Gigabit Ethernet (NET 0) connector as needed for OS support.  
See [Back Panel Connector Locations](#).
2. To connect to the Oracle ILOM service processor over the network, connect an Ethernet cable to the Ethernet port labeled NET MGT.  
See [Back Panel Connector Locations](#).
3. To access the Oracle ILOM command-line interface (CLI) locally, connect a serial null modem cable to the RJ-45 serial port labeled SER MGT.

To access the system console, connect the RJ-45 cable to a terminal or terminal emulator, log on to Oracle ILOM, and type `start /HOST/console`.

See [Back Panel Connector Locations](#).

## Back Panel Connector Locations

The following illustration shows and describes the locations of the back panel connectors. Use this information to set up the server, so that you can access diagnostic tools and manage the server during service.

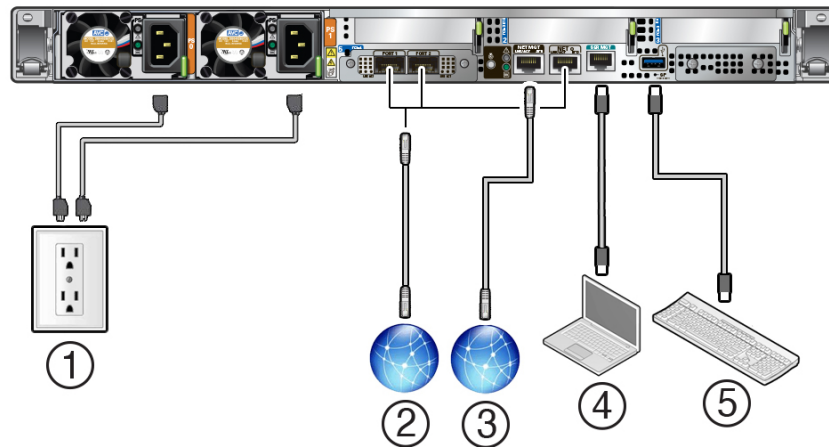

Callout	Cable Port or Expansion Slot	Description
1	Power supply 0 input power Power supply 1 input power	The server has two power supply connectors, one for each power supply. Do not attach power cables to the power supplies until you finish connecting the data cables to the server. The server goes into Standby power mode, and the Oracle ILOM service processor initializes when the AC power cables are connected to the power source. System messages might be lost after 60 seconds if the server is not connected to a terminal, PC, or workstation. <b>Note:</b> Oracle ILOM signals a fault on any installed power supply that is not connected to an AC power source, since it might indicate a loss of redundancy.
2	Ethernet ports: <ul style="list-style-type: none"> <li>(Optional) PORT 1 and PORT 2, 10/25/50/100/200 GbE QSFP ports</li> <li>NET 0, 100/1000BASE-T RJ-45 GbE port</li> </ul>	The three Gigabit Ethernet (GbE) ports enable you to connect the system to the network.

Callout	Cable Port or Expansion Slot	Description
3	Network management port (NET MGT)	The service processor NET MGT port is the optional connection to the Oracle ILOM service processor. The NET MGT port is configured by default to use Dynamic Host Configuration Protocol (DHCP). The service processor NET MGT port uses an RJ-45 cable for a 100/1000BASE-T connection.
4	Serial management port (SER MGT)	The service processor SER MGT port uses an RJ-45 cable and terminal (or emulator) to provide access to the Oracle ILOM command-line interface (CLI). Using Oracle ILOM, you can configure it to connect to the system console. <b>Note:</b> The serial management port does not support network connections.
5	USB port	The USB port supports hot-plugging. You can connect and disconnect a USB cable or a peripheral device while the server is running without affecting system operations.

## Configuring Serial Port Sharing

By default, the service processor (SP) controls the serial management (SER MGT) port and uses it to redirect the host serial console output. Using Oracle ILOM, you can assign the host console (COM1) as owner of the SER MGT port output, which allows the host console to output information directly to the SER MGT port. Serial port sharing is useful for Windows kernel debugging, because you can view non-ASCII character traffic output from the host console.

Set up the network on the SP before attempting to change the serial port owner to the host server. If the network is not set up first, and you switch the serial port owner to the host server, you cannot connect using the CLI or web interface to change the serial port owner back to the SP. To return the serial port owner setting to the SP, restore access to the serial port on the server. For details, refer to the Oracle Integrated Lights Out Manager (ILOM) 5.0 Documentation Library at [Oracle Integrated Lights Out Manager \(ILOM\) 5.0 Documentation](#).

If you accidentally lose access to Oracle ILOM, contact Oracle Service and follow the process to return the serial port ownership back to the SP.

You can assign serial port output using either the Oracle ILOM CLI interface or web interface, as described in the following sections:

- [Assign Serial Port Output Using the Oracle ILOM CLI](#)
- [Assign Serial Port Output Using the Oracle ILOM Web Interface](#)

### Assign Serial Port Output Using the Oracle ILOM CLI

1. Open an SSH session, and at the command line, log in to the SP Oracle ILOM CLI.

Log in as a user with root or administrator privileges. For example:

```
ssh root@ ipaddress
```

Where *ipaddress* is the IP address of the server SP.

For more information, see *Accessing Oracle ILOM in Oracle X9 Series Servers Administration Guide* at [Oracle x86 Servers Administration, Diagnostics, and Applications Documentation](#).

The Oracle ILOM CLI prompt (->) appears.

2. To set the serial port owner, type:

```
-> set System/SP/serial/portsharing owner=host
```

 **Note:**

The serial port sharing value, by default, is `owner=SP`.

3. Connect a serial host to the server.

## Assign Serial Port Output Using the Oracle ILOM Web Interface

1. Log in to the SP Oracle ILOM web interface.

Open a web browser and direct it using the IP address of the server SP. Log in as root or a user with administrator privileges. See *Accessing Oracle ILOM in Oracle X9 Series Servers Administration Guide* at [Oracle x86 Servers Administration, Diagnostics, and Applications Documentation](#).

2. On the Summary Information page, select ILOM Administration → Connectivity from the navigation menu on the left side of the screen.
3. Select the Serial Port tab.

 **Note:**

The serial port sharing setting, by default, is `Service Processor`.

4. In the Serial Port Settings page, select Host Server as the serial port owner.
5. Click Save for the changes to take effect.
6. Connect a serial host to the server.

## Server Operating System Names for the NVMe Storage Drives

If NVMe storage drives are installed in the server front panel, they are labeled NVMe0 through NVMe3. The server operating systems assign these storage drives different names. For the corresponding names assigned by the operating systems, see the following table.

 **Note:**

The drive names provided in the table assume that NVMe cabling between the motherboard NVMe connectors and the disk backplane is correct.

Storage Drive Labels	Names Assigned by the Server Operating Systems
NVMe0	PCIe Slot 100
NVMe1	PCIe Slot 101
NVMe2	PCIe Slot 102
NVMe3	PCIe Slot 103

## Ethernet Device Naming

This section contains information about the Gigabit Ethernet port (labeled NET 0) on the back panel of the server. For location information, see [Back Panel Connector Locations](#).

### Ethernet Port Device Naming

The device naming for the Ethernet interface is reported differently by different interfaces and operating systems. The following table shows the BIOS (physical) and operating system (logical) naming convention for the interface. This naming convention might vary depending on the conventions of your operating system and which devices are installed in the server.

 **Note:**

Naming used by the interfaces might vary from that listed below depending on which devices are installed in the system.

Port	Oracle Solaris	Oracle Linux 7 and 8	Windows (example default name, see note below)
Net 0	igb0	eno1	Ethernet

 **Note:**

For Windows, a port name such as Ethernet is used by default. However, actual port naming is based on the order of enumeration, typically during operating system installation. Additionally, Windows allows you to rename the ports to meet application-specific needs.

## MAC Address Mapping to Ethernet Ports

A system serial label that displays the MAC ID (and the associated barcode) for the server is attached to the top, front left side of the Oracle Server X9-2 server disk cage bezel.

This MAC ID (and barcode) corresponds to a hexadecimal (base 16) MAC address for a sequence of six consecutive MAC addresses. These six MAC addresses correspond to the server's network ports as shown in the following table.

Base MAC Address	Corresponding Ethernet Port
"base" + 0	NET 0
"base" + 1	Unassigned
"base" + 2	Unassigned
"base" + 3	Unassigned
"base" + 4	SP (NET MGT)
"base" + 5	Used only when Network Controller-Sideband Interface (NC-SI) sideband management is configured.

## Back Panel Pinhole Switch

Oracle Service personnel might instruct you to use the back panel pinhole switch to reset the SP, as shown in the following figure.

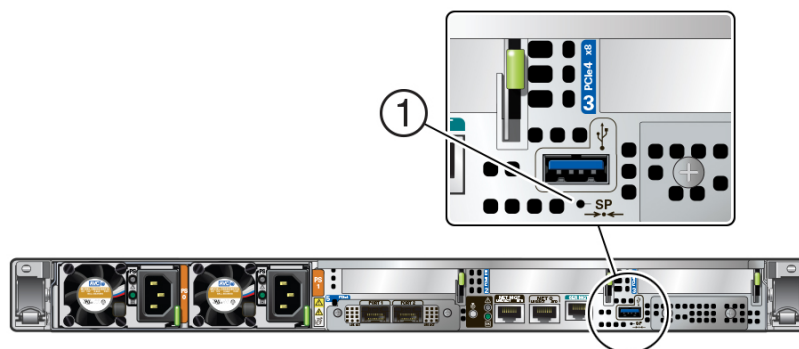

Callout	Icon	Description
1		SP Reset

## Getting Help

The following sections describe how to get additional help to resolve server-related problems.

- [Contacting Support](#)

- [Locating the Chassis Serial Number](#)

## Contacting Support

If the troubleshooting procedures in this chapter fail to solve your problem, use the following table to collect information that you might need to communicate to support personnel.

<b>System Configuration Information Needed</b>	<b>Your Information</b>
Service contract number	
System model	
Operating environment	
System serial number	
Peripherals attached to the system	
Email address and phone number for you and a secondary contact	
Street address where the system is located	
Superuser password	
Summary of the problem and the work being done when the problem occurred	
<b>Other Useful Information</b>	
IP address	
Server name (system host name)	
Network or internet domain name	
Proxy server configuration	

### Related Information

- [Locating the Chassis Serial Number](#)

## Locating the Chassis Serial Number

You might need your server serial number when you ask for service on your system. Record this number for future use. Use one of the following resources or methods to locate your server serial number.



- The serial number is located on the Radio-frequency Identification (RFID) label on the bottom left side of the front panel bezel, below the general status LEDs.  
For illustrations of the server front panel, see [Front and Back Panel Components](#).
- The serial number is recorded on a label that is attached to the top front surface of the system.
- The serial number is recorded on the yellow Customer Information Sheet (CIS) that is attached to your server packaging.
- Using Oracle ILOM:
  - From the command-line interface (CLI), type the command: `show /System`
  - From the web interface, view the serial number on the System Information screen.

## Auto Service Requests

Oracle Auto Service Requests (ASR) is available at no additional cost to customers with Oracle Premier Support. Oracle ASR is the fastest way to restore system availability if a hardware fault occurs. Oracle ASR software is secure and customer installable, with the software and documentation downloadable at [My Oracle Support](#). When you log in to My Oracle Support, refer to the "Oracle Auto Service Request" knowledge article document (ID 1185493.1) for instructions on downloading the Oracle ASR software.

When a hardware fault is detected, Oracle ASR opens a service request with Oracle and transfers electronic fault telemetry data to help expedite the diagnostic process. Oracle diagnostic capabilities then analyze the telemetry data for known issues and delivers immediate corrective actions. For security, the electronic diagnostic data sent to Oracle includes only what is needed to solve the problem. The software does not use any incoming Internet connections and does not include any remote access mechanisms.

For more information about Oracle ASR, go to [Oracle Premier Support](#).

# 3

## Preparing for Service

These sections describe safety considerations and provide prerequisite procedures and information to replace components in the server:

- [Safety Precautions](#)
- [Safety Symbols](#)
- [Electrostatic Discharge Safety](#)
- [FRU Key Identity Properties \(KIP\) Automated Update](#)
- [Required Tools](#)
- [Preparing the Server for Component Replacement](#)

### Related Topics

- [Returning the Server to Operation](#)

## Safety Precautions

For your protection, observe the following safety precautions when setting up your equipment:

- Follow all standard cautions, warnings, and instructions marked on the equipment and described in the *Oracle Server X9-2 Safety and Compliance Guide* and in the printed *Important Safety Information for Oracle's Hardware Systems*.
- Ensure that the voltage and frequency of your power source match the voltage and frequency that appear on the equipment's electrical rating label.
- Follow the electrostatic discharge safety practices as described in [Electrostatic Discharge Safety](#).
- Disconnect both power supply cords (if necessary) before servicing components.

 **Note:**

Power cords must be disconnected when servicing components that require cold service.

### Related Topics

- [Safety Symbols](#)
- [Electrostatic Discharge Safety](#)

## Safety Symbols

The following symbols might appear in this book. Note their meanings.

 **Caution:**

**Risk of personal injury or equipment damage.** To avoid personal injury or equipment damage, follow the instructions.

 **Caution:**

**Hot surface.** Avoid contact. Surfaces are hot and might cause personal injury if touched.

 **Caution:**

**Hazardous voltages are present.** To reduce the risk of electric shock and danger to personal health, follow the instructions.

**Related Topics**

- [Safety Precautions](#)
- [Electrostatic Discharge Safety](#)

## Electrostatic Discharge Safety

Devices that are sensitive to electrostatic discharge (ESD), such as the motherboard, PCIe cards, drives, processors, and memory cards require special handling.

 **Caution:**

The boards and drives contain electronic components that are extremely sensitive to static electricity. Ordinary amounts of static electricity from clothing or the work environment can destroy components. Do not touch the components along their connector edges.

Do the following when handling ESD-sensitive components:

- Use an antistatic wrist strap.  
Wear an antistatic wrist strap when handling components such as drive assemblies, boards, or cards. When servicing or removing server components, disconnect the power cords from the server. Attach an antistatic strap to your wrist and to a metal area on the chassis. Following this practice equalizes the electrical potentials between you and the server.

 **Note:**

An antistatic wrist strap is not included in the Ship Kit for the server. However, antistatic wrist straps are included with optional components.

- Use an antistatic mat.  
Place ESD-sensitive components such as the motherboard, DIMMs (memory modules), and other printed circuit boards on an antistatic mat. The following items can be used as an antistatic mat:
  - Antistatic bag used to wrap an Oracle replacement part
  - Oracle ESD mat (orderable item)
  - Disposable ESD mat (shipped with some replacement parts or optional system components)

#### Related Topics

- [Safety Precautions](#)
- [Safety Symbols](#)
- [Preparing the Server for Component Replacement](#)
- [Returning the Server to Operation](#)

## FRU Key Identity Properties (KIP) Automated Update

Oracle ILOM includes a key identity properties (KIP) auto-update feature that ensures product information that is used for service entitlement and warranty coverage is accurately maintained by the server at all times, including during hardware replacement activities.

The KIP includes the server product name, product part number (PPN), and product serial number (PSN). The KIP is stored in the FRUID (field-replaceable unit identifiers) container of the three server FRUs that are designated quorum members.

The quorum members include:

- Disk backplane (DBP), designated as a primary quorum member.
- Motherboard (MB), designated as a backup quorum member.
- Power supply (PS) 0, designated as a backup quorum member.

When a server FRU that contains the KIP is removed and a replacement component is installed, the KIP of the replacement component is programmed by Oracle ILOM to contain the same KIP as the other two components.



#### Note:

Only one of the quorum members can be replaced at a time. Automated updates can be completed only when two of the three quorum members contain matching key identity properties.

#### Related Topics

- [Servicing Power Supplies \(CRU\)](#)
- [Servicing the Disk Backplane \(FRU\)](#)
- [Servicing the Motherboard Assembly \(FRU\)](#)

## Required Tools

The server can be serviced with the following tools:

- Antistatic wrist strap
- Antistatic mat
- No. 2 Phillips screwdriver
- Torx (6 lobe) T10, T15, T25, and T30 screwdrivers
- 12.0 in-lbs/ft (inch-pounds/foot) torque driver

### Related Topics

- [Preparing for Service](#)

## Preparing the Server for Component Replacement

Before you can remove and install components that are inside the server, you must perform the procedures in some or all of the following tasks:

### Note:

When you are replace the storage drives or power supplies, not all of the procedures in this section are necessary. For more information, see the replacement procedures for those components.

- [Powering Down the Server](#)
- [Disconnect Cables From the Server](#)
- [Extend the Server to the Maintenance Position](#)
- [Remove the Server From the Rack](#)
- [Take Antistatic Measures](#)
- [Remove the Server Top Cover](#)

### Related Topics

- [Returning the Server to Operation](#)

## Powering Down the Server

To determine how you want to power off the server, view the options in the following table.

### Note:

Some server components, such as storage drives, power supplies, and fan modules are hot-pluggable. Components that are hot-pluggable do not require the server to be powered down when performing service procedures.

Description	Link
Power down the server gracefully to save all data and to prevent data from being corrupted. Performing a graceful shutdown ensures that the system is ready for restart.	<ul style="list-style-type: none"> <li>• <a href="#">Power Down Server Gracefully Using the Oracle ILOM CLI</a></li> <li>• <a href="#">Power Down Server Gracefully Using the Oracle ILOM Web Interface</a></li> <li>• <a href="#">Power Down Server Gracefully Using the On/Standby Button</a></li> </ul>
If the server is not responding, or you must shut down the server quickly, perform an immediate shutdown.	<ul style="list-style-type: none"> <li>• <a href="#">Power Down the Server for Immediate Shutdown Using the On/Standby Button</a></li> <li>• <a href="#">Power Down the Server for Immediate Shutdown Using the Oracle ILOM CLI</a></li> <li>• <a href="#">Power Down the Server for Immediate Shutdown Using the Oracle ILOM Web Interface</a></li> </ul>

### Related Topics

- [Power On the Server](#)

## Power Down Server Gracefully Using the Oracle ILOM CLI

Performing a graceful shutdown ensures that all of your data is saved and the system is ready for restart.

1. Log in to the server as superuser or equivalent.

Depending on the nature of the problem, you might want to view the system status or the log files or run diagnostics before you shut down the system. For more information, see the Oracle ILOM 5.0 Documentation Library at [Oracle Integrated Lights Out Manager \(ILOM\) 5.0 Documentation](#).

2. Notify affected users that the server will be powered down.
3. Save any open files, and quit all running applications.  
Refer to your application documentation for specific information on these processes.
4. Log in to the Oracle ILOM command-line interface (CLI) using an Administrator account.  
Refer to *Accessing Oracle ILOM in Oracle Servers X9-2 and X9-2L Installation Guide* at [Oracle Server X9-2 Documentation](#).
5. At the Oracle ILOM prompt, shut down the operating system: stop command

```
-> stop /System
```

### Note:

The `stop /System` command does not guarantee a system shutdown. This command is only a request to the host operating system (OS) to perform a system shutdown. To ensure a system shutdown, see [Power Down the Server for Immediate Shutdown Using the Oracle ILOM CLI](#).

If the system is running Oracle Solaris OS, refer to the Oracle Solaris system administration documentation for additional information.

The host server performs an orderly power shutdown to Standby power mode, and the System OK LED on the front panel begins blinking. See [Server System-Level Status Indicators](#).

6. Disconnect the power and cables from the server.  
See [Disconnect Cables From the Server](#).

**▲ Caution:**

When you power down the server using Oracle ILOM, the server enters Standby power mode. Power is still directed to the service processor remote management subsystem and power supply fans. To completely power off the server, you must disconnect the power cords from the power supplies.

**Related Topics**

- [Power Down Server Gracefully Using the Oracle ILOM Web Interface](#)
- [Power Down Server Gracefully Using the On/Standby Button](#)
- [Power Down the Server for Immediate Shutdown Using the On/Standby Button](#)
- [Power On the Server](#)

## Power Down Server Gracefully Using the Oracle ILOM Web Interface

1. Log in to the server as superuser or equivalent.  
Depending on the nature of the problem, you might want to view the system status or the log files or run diagnostics before you shut down the system. For more information, see the Oracle ILOM 5.0 Documentation Library at [Oracle Integrated Lights Out Manager \(ILOM\) 5.0 Documentation](#).
2. Notify affected users that the server will be powered down.
3. Save any open files and quit all running applications.  
Refer to your application documentation for specific information about these processes.
4. Log in to the Oracle ILOM web interface using an Administrator account.  
Refer to *Accessing Oracle ILOM in Oracle Servers X9-2 and X9-2L Installation Guide* at [Oracle Server X9-2 Documentation](#).  
The Oracle ILOM web interface System Information → Summary Information page appears.
5. In the left pane, click Host Management → Power Control, and select Graceful Shutdown and Power Off from the Action list.
6. Click Save and then click OK.  
The host server performs an orderly power shutdown to Standby power mode, and the System OK LED on the front panel begins blinking. See [Server System-Level Status Indicators](#).
7. Disconnect the power cords and data cables from the server.  
See [Disconnect Cables From the Server](#).

 **Caution:**

When you power down the server using Oracle ILOM, the server enters Standby power mode. Power is still directed to the service processor and power supply fans. To completely power off the server, you must disconnect the power cords from the power supplies.

**Related Topics**

- [Power Down Server Gracefully Using the Oracle ILOM CLI](#)
- [Power Down Server Gracefully Using the On/Standby Button](#)
- [Power Down the Server for Immediate Shutdown Using the On/Standby Button](#)
- [Power On the Server](#)

## Power Down Server Gracefully Using the On/Standby Button

1. Press and quickly release the On/Standby button on the front panel.

This action causes ACPI-enabled operating systems to perform an orderly shutdown of the operating system. Servers not running ACPI-enabled operating systems shut down to Standby power mode immediately.

When main power is off, the System OK LED on the front panel begins blinking, indicating that the server is in Standby power mode. See [Server System-Level Status Indicators](#).

2. Disconnect the power cords and data cables from the server.

See [Disconnect Cables From the Server](#).

 **Caution:**

When you power down the server using the On/Standby button, the server enters Standby power mode. Power is still directed to the service processor and power supply fans. To completely power off the server, you must disconnect the power cords from the power supplies.

**Related Topics**

- [Power Down Server Gracefully Using the Oracle ILOM CLI](#)
- [Power Down Server Gracefully Using the Oracle ILOM Web Interface](#)
- [Power Down the Server for Immediate Shutdown Using the On/Standby Button](#)
- [Power On the Server](#)

## Power Down the Server for Immediate Shutdown Using the On/Standby Button

 **Caution:**

An immediate power-off might corrupt system data, therefore, use this procedure to power down the server only after attempting the graceful power down procedure.



1. Press and hold the On/Standby button for four seconds to force the Main power off and to enter Standby power mode.

When the Main power is off, the System OK LED on the front panel begins blinking, indicating that the server is in Standby power mode. See [Server System-Level Status Indicators](#).

2. Disconnect the power and data cables from the server.

See [Disconnect Cables From the Server](#).

**▲ Caution:**

When you press the On/Standby button to enter Standby power mode, power is still directed to the service processor and power supply fans. To completely power off the server, you must disconnect the power cords from the power supplies.

**Related Topics**

- [Power Down Server Gracefully Using the Oracle ILOM CLI](#)
- [Power Down Server Gracefully Using the Oracle ILOM Web Interface](#)
- [Power Down Server Gracefully Using the On/Standby Button](#)
- [Power Down the Server for Immediate Shutdown Using the Oracle ILOM CLI](#)
- [Power Down the Server for Immediate Shutdown Using the Oracle ILOM Web Interface](#)
- [Power On the Server](#)

## Power Down the Server for Immediate Shutdown Using the Oracle ILOM CLI

**▲ Caution:**

An immediate power-off might corrupt system data, therefore, use this procedure to power down the server only after attempting the graceful power down procedure.

1. Log in to the Oracle ILOM command-line interface (CLI) using an Administrator account.

Oracle ILOM displays the default command prompt (->), indicating that you have successfully logged in to Oracle ILOM.

2. At the CLI prompt, type the following command:

```
-> stop -f /System
```

The server powers down immediately to Standby power mode.

3. Disconnect the power and data cables from the server.

See [Disconnect Cables From the Server](#).

**▲ Caution:**

When the server is powered down, it enters Standby power mode. In standby power mode, power is still directed to the service processor and power supply fans. To completely power off the server, you must disconnect the power cords from the power supplies.

**Related Topics**

- [Power Down the Server for Immediate Shutdown Using the On/Standby Button](#)
- [Power Down the Server for Immediate Shutdown Using the Oracle ILOM Web Interface](#)
- [Power On the Server](#)

## Power Down the Server for Immediate Shutdown Using the Oracle ILOM Web Interface

**▲ Caution:**

An immediate power-off might corrupt system data, therefore, use this procedure to power down the server only after attempting the graceful power down procedure.

1. Log in to the Oracle ILOM web interface using an Administrator account.  
The Oracle ILOM web interface System Information page appears.
2. In the left pane, click Host Management → Power Control, and select Immediate Power Off in the Select Action list.
3. Click Save, then click OK.  
The server powers down immediately to Standby power mode.
4. Disconnect the power and data cables from the server.  
See [Disconnect Cables From the Server](#).

**▲ Caution:**

When the server is powered down, it enters Standby power mode. In standby power mode, power is still directed to the service processor and power supply fans. To completely power off the server, you must disconnect the power cords from the power supplies.

**Related Topics**

- [Power Down the Server for Immediate Shutdown Using the On/Standby Button](#)
- [Power Down Server Gracefully Using the Oracle ILOM CLI](#)
- [Power On the Server](#)

## Disconnect Cables From the Server

### **Caution:**

The system supplies Standby power to the circuit boards when the power cords are connected even when the system is powered off.

1. Label all cables connected to the server. cables data and power disconnecting
2. Power down the server.  
See [Powering Down the Server](#).
3. Disconnect the power cords from the rear of the server.
4. Disconnect all data cables from the rear of the server.

### **Related Topics**

- [Back Panel Components and Cable Connections](#)
- [Powering Down the Server](#)
- [Remove the Server From the Rack](#)
- [Reconnect Data Cables and Power Cords](#)

## Extend the Server to the Maintenance Position

The following components can be serviced with the server in the maintenance position:

- Storage drives
- Fan modules
- Power supplies
- PCIe risers
- PCIe cards and cables
- NVMe cables
- DDR4 DIMMs
- M.2 flash SSDs
- System battery
- OCP NIC
- Processors
- Disk backplane
- Motherboard assembly

If the server is installed in a rack with extendable slide-rails, use this procedure to extend the server to the maintenance position.

1. To prevent the rack from tipping forward when the server is extended, extend all rack anti-tilt mechanisms.

Refer to *Stabilize the Rack* in *Oracle Servers X9-2 and X9-2L Installation Guide* at [Oracle Server X9-2 Documentation](#). Also refer to the *Oracle Rack Cabinet 1242 User's Guide* at [Oracle Rack Cabinet 1242 Documentation Library](#).

2. Verify that no cables will be damaged or will interfere when the server is extended.

Although the cable management arm (CMA) that is supplied with the server is hinged to accommodate extending the server, ensure that all cables and cords are capable of extending.

3. From the front of the server, open and hold the left and right release latch covers in the open position [1].

When in an open position, the release latch covers engage the slide-rail release latches [1].

**▲ Caution:**

Deploy any rack anti-tilt mechanism before releasing the slide-rail release latches.

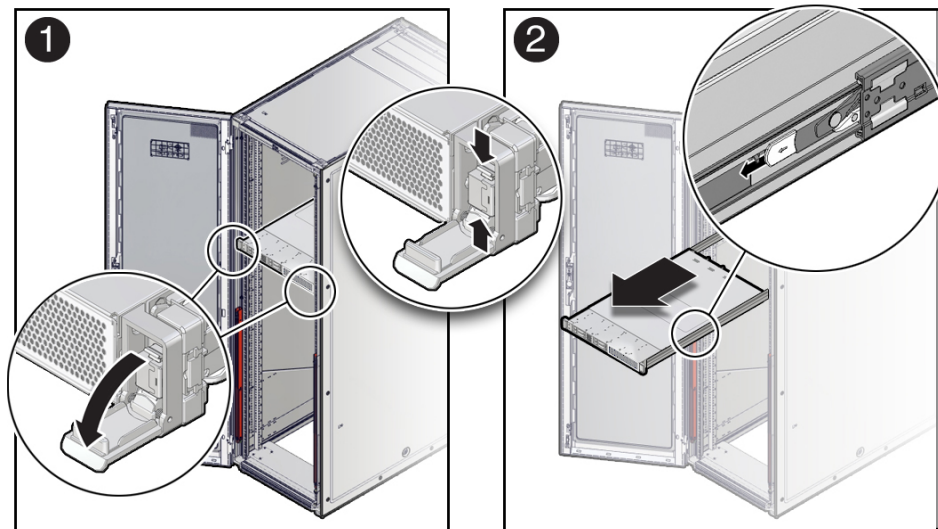

4. While the release latch covers are in the open position, slowly pull the server forward until the slide-rails latch into a locked position [2].

The server is now in the extended maintenance position.

**Related Topics**

- [Disconnect Cables From the Server](#)
- [Remove the Server From the Rack](#)
- [Reinstall the Server Into the Rack](#)

## Remove the Server From the Rack

### **Caution:**

The server weighs approximately 35.0 lbs (15.88 kg). Two people are required to dismount and carry the chassis.

1. Disconnect all the cables and power cords from the server.
2. Remove the cable management arm (CMA).  
Refer to *Remove the Cable Management Arm in Oracle Servers X9-2 and X9-2L Installation Guide* at [Oracle Server X9-2 Documentation](#).
3. Extend the server to the maintenance position.  
See [Extend the Server to the Maintenance Position](#).
4. From the front of the server, pull the gray slide-rail release tabs toward the front of the server, and pull the server out of the rack until it is free of the rack rails.  
A slide-rail release tab is located on each slide-rail.

### **Note:**

To pull the gray slide-rail release tab, place your finger in the center of the tab, not on the end, and apply pressure as you pull the tab toward the front of the server.

5. Set the server on a sturdy work surface.

### **Related Topics**

- [Disconnect Cables From the Server](#)
- [Take Antistatic Measures](#)
- [Extend the Server to the Maintenance Position](#)
- [Reinstall the Server Into the Rack](#)

## Take Antistatic Measures

1. Prepare an antistatic surface on which to set parts during removal and installation.  
Place electrostatic discharge ESD-sensitive components such as the printed circuit boards on an antistatic mat. You can use the following items as an antistatic mat:
  - Antistatic bag used to wrap a replacement part
  - Oracle ESD mat (orderable item)
  - Disposable ESD mat (shipped with some replacement parts or optional system components)
2. Attach an antistatic wrist strap.

When servicing or removing server components, attach an antistatic strap to your wrist and then to a metal area on the chassis. Then disconnect the power cords from the server.

 **Note:**

An antistatic wrist strap is not included in the Ship Kit for the server. However, antistatic wrist straps might be included with options and components.

**Related Topics**

- [Remove Antistatic Measures](#)

## Remove the Server Top Cover

Servicing some components requires that the top cover be removed.

1. Ensure that the AC power cords are disconnected from the server power supplies.

 **Note:**

Fan modules are hot-pluggable and do not require AC power cables to be disconnected from the server power supplies.

2. If the release button latch is in the locked position, use a Torx T15 screwdriver to turn the release button latch clockwise to the unlocked position.

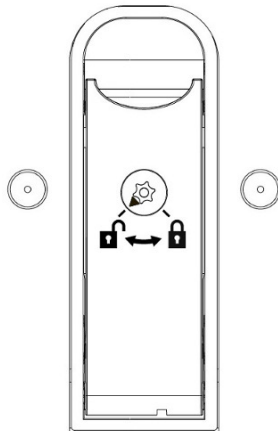

3. Unlatch the top cover [1].

Lift up on the release button on top of the server cover. Lifting the release button slides the server cover toward the rear of the chassis for easy removal.

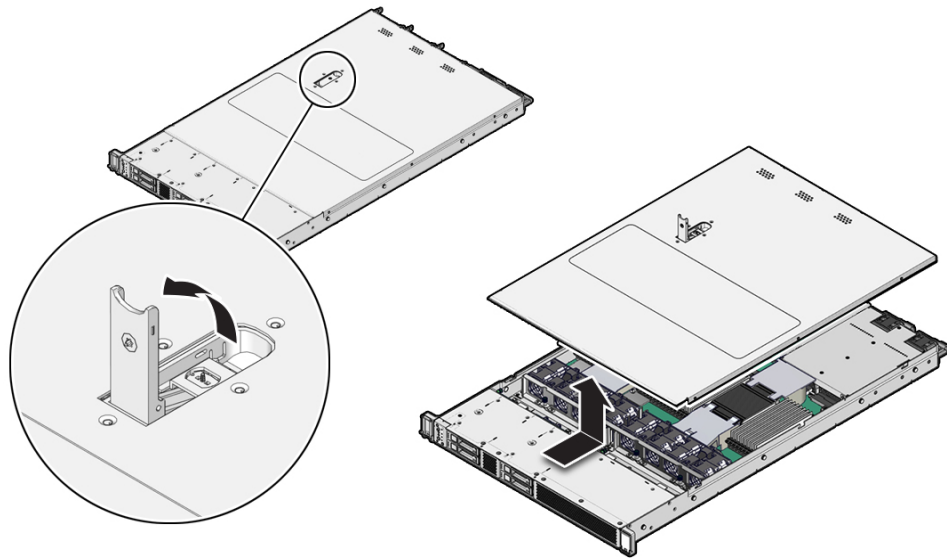

4. Lift up and remove the top cover [2].

**Related Topics**

- [Take Antistatic Measures](#)
- [Install the Server Top Cover](#)

# 4

## Servicing Storage Drives (CRU)

This section describes how to service storage drives. Storage drives are customer-replaceable units (CRUs) that do not require you to power off the server. For more information about CRUs, see [Illustrated Parts Breakdown](#) and [Customer-Replaceable Units](#).

- [Storage Drives Hot-Plug Conditions](#)
- [Storage Drive Failure and RAID](#)
- [Storage Drive Locations and Numbering](#)
- [Removing and Replacing a Storage Drive](#)
- [Removing and Replacing an NVMe Storage Drive Using Oracle Solaris](#)
- [Removing and Replacing an NVMe Storage Drive Using Oracle Linux](#)
- [Removing and Replacing an NVMe Storage Drive Using Microsoft Windows Server](#)

### Related Topics

- [Remove and Install Filler Panels](#)

## Storage Drives Hot-Plug Conditions

The hard-disk drives (HDDs), solid-state drives (SSDs), or NVMe SSD drives that are installed in the server are in most cases hot-pluggable. The hot-plug capability depends on how the drives are configured and whether the drive is an NVMe device. To hot-plug a drive you must take the drive offline before you can remove it. When you take the drive offline, you prevent any application from accessing the drive and remove the logical software links to the drive. For an NVMe storage drive, you must not only take the drive offline, but also power down the drive slot.

The following conditions inhibit the ability to perform hot-plugging of a drive:

- The drive provides the operating system, and the operating system is not mirrored on another drive.
- The drive cannot be logically isolated from the online operations of the server.
- The operating system does not support hot plug for the drive.

If any of these disk drive conditions are true, then you must shut down the system before you replace the drive. See [Powering Down the Server](#).

### Note:

Replacing a storage drive does not require removing the server from a rack.



### Related Topics

- [Storage Drive Status Indicators](#)
- [Removing and Replacing a Storage Drive](#)
- [Removing and Replacing an NVMe Storage Drive Using Oracle Solaris](#)
- [Removing and Replacing an NVMe Storage Drive Using Oracle Linux](#)
- [Removing and Replacing an NVMe Storage Drive Using Microsoft Windows Server](#)

## Storage Drive Failure and RAID

A single storage drive failure does not cause a data failure if you configure the storage drives as a mirrored RAID 1 volume (optional). The storage drive can be removed, and when a new storage drive is inserted, the contents are automatically rebuilt from the rest of the array with no need to reconfigure the RAID parameters. If you configured the replaced storage drive as a hot-spare, the new storage drive is automatically configured as a new hot-spare.

For instructions for configuring RAID on the server, refer to *Configuring Storage Devices for Operating System Installation in Oracle Servers X9-2 and X9-2L Installation Guide* at [Oracle Server X9-2 Documentation](#).

## Storage Drive Locations and Numbering

The following illustration shows the location of the drives and the internal system software designations for the drives. For information on storage drive status indicators (LEDs), see [Storage Drive Status Indicators](#).

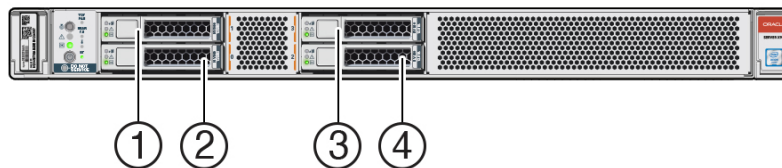

Callout	Description
1	Storage drive 1 NVMe
2	Storage drive 0 NVMe
3	Storage drive 3 NVMe
4	Storage drive 2 NVMe



**Note:**

The NVMe storage drives are labeled NVMe0 through NVMe3; however, operating systems installed on the server assign different names to the NVMe storage drives. For the corresponding names assigned to the NVMe storage drives by server operating systems, see [Server Operating System Names for the NVMe Storage Drives](#).

## Removing and Replacing a Storage Drive

The following sections describe how to remove and replace an HDD or SSD storage drive.

- [Remove a Storage Drive](#)
- [Install a Storage Drive](#)

### Remove a Storage Drive

1. Prepare the system for the drive removal.  
See [Take Antistatic Measures](#).
2. Identify the location of the drive that you want to remove.  
For storage drive locations, see [Storage Drive Locations and Numbering](#).
3. Remove the storage drive.  
See the procedures for your operating system.



**Note:**

NVMe storage drives are supported only on servers that are running Oracle Solaris, Oracle Linux, or Microsoft Windows Server.

- [Removing and Replacing an NVMe Storage Drive Using Oracle Solaris](#)
  - [Removing and Replacing an NVMe Storage Drive Using Oracle Linux](#)
  - [Removing and Replacing an NVMe Storage Drive Using Microsoft Windows Server](#)
4. Push the latch release button to open the drive latch [1]. latch release button storage drive storage drives latch release button

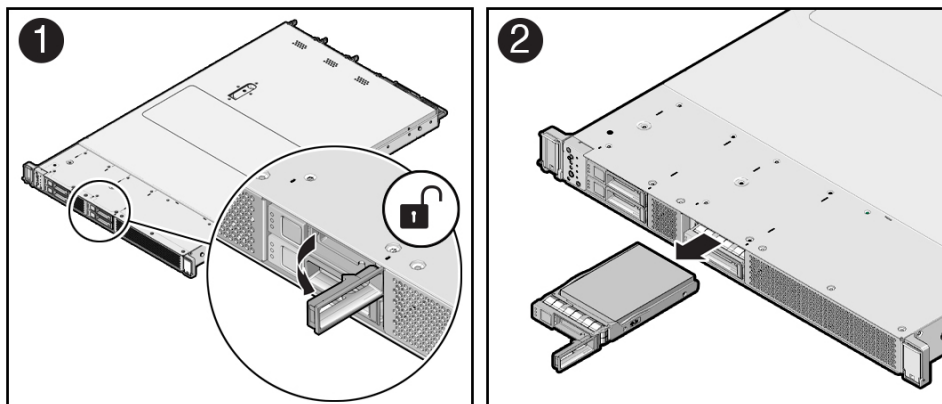

**▲ Caution:**

The latch is not an ejector. Do not open the latch too far to the right. Doing so can damage the latch.

5. Grasp the latch and pull the drive out of the drive slot [2].
6. Consider your next steps:
  - If you are replacing the drive, continue to [Install a Storage Drive](#).
  - If you are not replacing the drive, install a filler panel in the empty drive slot to maintain proper airflow and perform administrative tasks to configure the server to operate without the drive.

For information on how to install a storage drive filler panel, see [Remove and Install Filler Panels](#).

**Related Topics**

- [Storage Drive Status Indicators](#)
- [Storage Drives Hot-Plug Conditions](#)
- [Storage Drive Failure and RAID](#)
- [Install a Storage Drive](#)

## Install a Storage Drive

1. Remove the replacement drive from its packaging and place the drive on an antistatic mat.
2. If necessary, remove the drive filler panel.

See [Remove and Install Filler Panels](#).

3. Align the replacement drive with the drive slot.

The drive is physically addressed according to the slot in which it is installed. It is important to install a replacement drive in the same slot as the drive that you removed.

4. Slide the drive into the slot until the drive is fully seated [1].

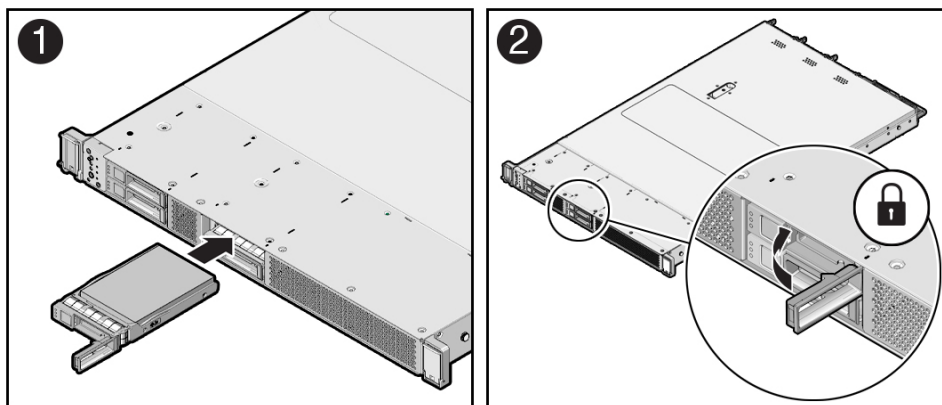

5. Close the drive latch to lock the drive in place [2].
6. Perform administrative tasks to reconfigure the drive.

The procedures that you perform at this point depend on how your data is configured. You might need to partition the drive, create file systems, load data from backups, or have the drive updated from a RAID configuration.

#### Related Topics

- [Storage Drive Status Indicators](#)
- [Storage Drives Hot-Plug Conditions](#)
- [Storage Drive Failure and RAID](#)
- [Remove a Storage Drive](#)

## Removing and Replacing an NVMe Storage Drive Using Oracle Solaris

The following sections describe how to remove and replace an NVMe storage drive on a server that is running the Oracle Solaris operating system.

- [Unmount an NVMe Storage Drive](#)
- [Remove an NVMe Storage Drive](#)
- [Verify Removal of an NVMe Storage Drive](#)
- [Install an NVMe Storage Drive](#)
- [Power On an NVMe Storage Drive and Attach a Device Driver](#)

#### Related Topics

- [Storage Drive Status Indicators](#)
- [Storage Drives Hot-Plug Conditions](#)
- [Storage Drive Failure and RAID](#)
- [Storage Drive Locations and Numbering](#)

## Unmount an NVMe Storage Drive

1. Log in to Oracle Solaris that is running on the server.
2. To find the NVMe drive slot number, type:

```
# hotplug list -lc
```

This command produces output similar to the following for each of the NVMe drives installed in the server:

```
# hotplug list -lc
Connection          State          Description Path
-----
Slot0               EMPTY         PCIe-Native /pci@0,0/pci8086,a190@1c
/SYS/DBP/HDD2/NVME  EMPTY         PCIe-Native /pci@4,0/pci8086,347a@2
/SYS/DBP/HDD3/NVME  EMPTY         PCIe-Native /pci@4,0/pci8086,347b@3
/SYS/DBP/HDD0/NVME  ENABLED       PCIe-Native /pci@4,0/pci8086,347c@4
/SYS/DBP/HDD1/NVME  EMPTY         PCIe-Native /pci@4,0/pci8086,347d@5
```

3. To prepare the NVMe drive for removal, that is, to detach the device driver and power off the drive slot, type the following commands:

```
# hotplug poweroff /SYS/DBP/HDD0/NVME
```

```
# hotplug list -lc
```

The following output appears for the NVMe drive that has been unmounted:

```
# hotplug poweroff /SYS/DBP/HDD0/NVME
# hotplug list -lc
Connection          State          Description Path
-----
Slot0               EMPTY         PCIe-Native /pci@0,0/pci8086,a190@1c
/SYS/DBP/HDD2/NVME  EMPTY         PCIe-Native /pci@4,0/pci8086,347a@2
/SYS/DBP/HDD3/NVME  EMPTY         PCIe-Native /pci@4,0/pci8086,347b@3
/SYS/DBP/HDD0/NVME  PRESENT       PCIe-Native /pci@4,0/pci8086,347c@4
/SYS/DBP/HDD1/NVME  EMPTY         PCIe-Native /pci@4,0/pci8086,347d@5
```

4. Verify that the OK to Remove indicator (LED) on the NVMe storage drive is lit.

## Remove an NVMe Storage Drive

Perform this procedure to physically remove an NVMe storage drive from the server.

1. Identify the physical location of the NVMe drive that you want to remove.  
For storage drive locations, see [Storage Drive Locations and Numbering](#).
2. Verify that the OK to Remove indicator (LED) on the NVMe storage drive is lit.
3. On the drive that you plan to remove, push the latch release button to open the drive latch.
4. Grasp the latch and pull the drive out of the drive slot.  
See [Remove a Storage Drive](#).
5. Consider your next steps:
  - If you are replacing the drive, continue to [Install an NVMe Storage Drive](#).

- If you are not replacing the drive, install a filler panel in the empty drive slot to maintain proper airflow and perform administrative tasks to configure the server to operate without the drive.

For information on how to install a storage drive filler panel, see [Remove and Install Filler Panels](#).

## Verify Removal of an NVMe Storage Drive

- To verify that the NVMe drive has been removed, type:

```
# hotplug list -lc
```

The following output appears for the NVMe drive that you removed:

```
# hotplug list -lc
Connection          State          Description Path
-----
Slot0               EMPTY         PCIe-Native /pci@0,0/pci8086,a190@1c
/SYS/DBP/HDD2/NVME  EMPTY         PCIe-Native /pci@4,0/pci8086,347a@2
/SYS/DBP/HDD3/NVME  EMPTY         PCIe-Native /pci@4,0/pci8086,347b@3
/SYS/DBP/HDD0/NVME  EMPTY         PCIe-Native /pci@4,0/pci8086,347c@4
/SYS/DBP/HDD1/NVME  EMPTY         PCIe-Native /pci@4,0/pci8086,347d@5
```

## Install an NVMe Storage Drive

Perform this procedure to physically install an NVMe storage drive into the server.

### Note:

After you physically remove an NVMe storage drive from the server, wait at least 10 seconds before installing a replacement drive.

1. Remove the replacement drive from its packaging and place the drive on an antistatic mat.
2. If necessary, remove the drive filler panel.
3. Align the replacement drive with the drive slot.

The drive is physically addressed according to the slot in which it is installed. It is important to install a replacement drive in the same slot as the drive that you removed.

4. Slide the drive into the slot until the drive is fully seated.  
See [Install a Storage Drive](#).
5. Close the drive latch to lock the drive in place.  
See [Install a Storage Drive](#).

## Power On an NVMe Storage Drive and Attach a Device Driver

1. Type: `# hotplug enable /SYS/DBP/HDD0/NVME`
2. Type: `# hotplug list -lc`

The following status is displayed for the NVMe storage drive.

```
# hotplug enable /SYS/DBP/HDD0/NVME
# hotplug list -lc
Connection          State          Description Path
-----
Slot0               EMPTY         PCIe-Native /pci0,0/pci8086,a190@1c
/SYS/DBP/HDD2/NVME  EMPTY         PCIe-Native /pci4,0/pci8086,347a@2
/SYS/DBP/HDD3/NVME  EMPTY         PCIe-Native /pci4,0/pci8086,347b@3
/SYS/DBP/HDD0/NVME  ENABLED       PCIe-Native /pci4,0/pci8086,347c@4
/SYS/DBP/HDD1/NVME  EMPTY         PCIe-Native /pci4,0/pci8086,347d@5
```

3. To check the NVMe drive health, firmware level, temperature, get error log, SMART data, security erase, low level format, and other data, type:

```
# nvmeadm --help
```

## Removing and Replacing an NVMe Storage Drive Using Oracle Linux

The following sections describe how to remove and replace an NVMe storage drive on a server that is running the Oracle Linux operating system.

- [Unmount an NVMe Storage Drive](#)
- [Remove an NVMe Storage Drive](#)
- [Verify Removal of an NVMe Storage Drive](#)
- [Install an NVMe Storage Drive](#)
- [Power On an NVMe Storage Drive and Attach a Device Driver](#)
- [Verify Operation of an NVMe Storage Drive](#)

### Related Topics

- [Storage Drive Status Indicators](#)
- [Storage Drives Hot-Plug Conditions](#)
- [Storage Drive Failure and RAID](#)
- [Storage Drive Locations and Numbering](#)

## Unmount an NVMe Storage Drive

1. Log in to Oracle Linux that is running on the server.
2. Remove the NVMe storage device path.
  - a. To find the PCIe addresses (Bus Device Function), type:

```
# find /sys/devices | egrep `nvme[0-9][0-9]?$`
```

This command returns output similar to the following example, with the PCIe addresses in bold text:

```
/sys/devices/
pci0000:80/0000:80:03.0/0000:b0:00.0/0000:b1:04.0/0000:b2:00.0/misc/nvme0
/sys/devices/
pci0000:80/0000:80:03.0/0000:b0:00.0/0000:b1:05.0/0000:b4:00.0/misc/nvme1
```

- b. To obtain the slot number (APIC ID) for the bus address, type the following command to list the PCIe slot numbers with corresponding bus addresses:

```
# egrep -H `.*` /sys/bus/pci/slots/*/address
```

This command returns output similar to the following example, with the bus addresses for the corresponding NVMe instances in bold text.:

 **Note:**

In the above output, notice that the instance names for the NVMe drives do not correspond to the NVMe drive labels on the front of the server. That is, `pci/slots/12/address: 0000:b2:00` corresponds to instance `nvme0`; however, on the front of the server, this drive is labeled `NVMe2`. For a table that shows the relationship between the `pci/slot#` and the NVMe storage drive label on the front of the server, see [Server Operating System Names for the NVMe Storage Drives](#).

```
/sys/bus/pci/slots/10/address:0000:b8:00
/sys/bus/pci/slots/11/address:0000:b6:00
/sys/bus/pci/slots/12/address:0000:b2:00 (instance nvme0, pcie slot 12,
drive label nvme2)
/sys/bus/pci/slots/13/address:0000:b4:00 (instance nvme1, pcie slot 13,
drive label nvme3)
```

- c. Disconnect all users from the NVMe drive and back up the NVMe drive data, as needed.
- i. Use the `umount` command to unmount any file systems that are mounted on the device.
  - ii. Remove the device from any multiple device (md) and Logical Volume Manager (LVM) volume using the device.
 

If the device is a member of an LVM Volume group, then it might be necessary to move data off the device using the `pvmove` command. Use the `vgreduce` command to remove the physical volume. Optionally, use the `pvremove` command to remove the LVM metadata from the disk.
  - iii. If the device uses multipathing, run `multipath -l` and note all the paths to the device. Then, remove the multipathed device using the `multipath -f device` command.
  - iv. Run the `blockdev --flushbufs device` command to flush any outstanding I/O to all paths to the device.
3. To prepare the NVMe drive for removal, that is, to detach the NVMe device driver and power off the NVMe drive slot, type:

```
# echo 0 > /sys/bus/pci/slots/$slot/power
```

Where `$slot` is the slot number obtained in [Step 2.b](#) above.

4. Verify that the OK to Remove indicator (LED) on the NVMe drive is lit.

## Remove an NVMe Storage Drive

Perform this procedure to physically remove an NVMe storage drive from the server.

1. Identify the location of the NVMe drive that you want to remove.



For storage drive locations, see [Storage Drive Locations and Numbering](#).

2. Verify that the OK to Remove indicator (LED) on the NVMe drive is lit.
3. On the NVMe drive you plan to remove, push the latch release button to open the drive latch.
4. Grasp the latch and pull the drive out of the drive slot.

[Remove a Storage Drive](#).

5. Consider your next steps:
  - If you are replacing the drive, continue to [Verify Removal of an NVMe Storage Drive](#).
  - If you are not replacing the drive, install a filler panel in the empty drive slot to maintain proper airflow and perform administrative tasks to configure the server to operate without the drive.

For information on how to install a storage drive filler panel, see [Remove and Install Filler Panels](#).

## Verify Removal of an NVMe Storage Drive

1. To check the NVMe drive enumeration to verify that the NVMe drive has been removed, type:

```
# lspci -nnd :0a54
```

2. View the command output and verify that the entry for the slot number that was disabled no longer appears.

This command returns output similar to the following:

```
86:00.0 Non-Volatile memory controller [0108]: Intel Corporation Device [8086:0a54]
8d:00.0 Non-Volatile memory controller [0108]: Intel Corporation Device [8086:0a54]
d9:00.0 Non-Volatile memory controller [0108]: Intel Corporation Device [8086:0a54]
e0:00.0 Non-Volatile memory controller [0108]: Intel Corporation Device [8086:0a54]
```

## Install an NVMe Storage Drive

Perform this procedure to physically install an NVMe storage drive into the server.

After you physically remove an NVMe drive from the server, wait at least 10 seconds before installing a replacement drive.

1. Remove the replacement drive from its packaging and place the drive on an antistatic mat.
2. If necessary, remove the drive filler panel.
3. Align the replacement drive with the drive slot.

The drive is physically addressed according to the slot in which it is installed. It is important to install a replacement drive in the same slot as the drive that was removed.

4. Slide the drive into the slot until the drive is fully seated.

See [Install a Storage Drive](#).

5. Close the drive latch to lock the drive in place [2].

See [Install a Storage Drive](#).

## Power On an NVMe Storage Drive and Attach a Device Driver

- To power on the slot and attach the device driver, type:

```
# echo 1 > /sys/bus/pci/slots/$slot/power
```

Where *\$slot* is the slot number for the NVMe storage drive.

## Verify Operation of an NVMe Storage Drive

- To verify that an NVMe drive is operating properly, do one of the following:
  - Check the `/var/log/messages` log file.
  - Type: `# ls -l /dev/nvme*`

# Removing and Replacing an NVMe Storage Drive Using Microsoft Windows Server

The following sections describe how to remove and replace an NVMe storage drive on a server that is running the Microsoft Windows Server operating system.



### Note:

NVMe storage drive hot plug is not supported for an Oracle Server X9-2 running Microsoft Windows Server. The system must be powered down before removing and replacing an NVMe storage drive.

- [Remove an NVMe Storage Drive](#)
- [Install an NVMe Storage Drive](#)

### Related Topics

- [Storage Drive Status Indicators](#)
- [Storage Drives Hot-Plug Conditions](#)
- [Storage Drive Failure and RAID](#)
- [Storage Drive Locations and Numbering](#)

## Remove an NVMe Storage Drive

Perform this procedure to physically remove an NVMe storage drive from the server.

1. Power down the server that contains the storage drive to be removed.

See [Powering Down the Server](#).

2. On the NVMe drive you plan to remove, push the latch release button to open the drive latch.  
See [Remove a Storage Drive](#).
3. Grasp the latch and pull the drive out of the drive slot.
4. Consider your next steps:
  - If you are replacing the drive, continue to [Install an NVMe Storage Drive](#).
  - If you are not replacing the drive, install a filler panel in the empty drive slot to maintain proper airflow and perform administrative tasks to configure the server to operate without the drive.

For information on how to install a storage drive filler panel, see [Remove and Install Filler Panels](#).

## Install an NVMe Storage Drive

Perform this procedure to physically install an NVMe storage drive into the server.

1. Remove the replacement drive from its packaging and place the drive on an antistatic mat.
2. If necessary, remove the drive filler panel.
3. Align the replacement drive with the drive slot.

The drive is physically addressed according to the slot in which it is installed. It is important to install a replacement drive in the same slot as the drive that was removed.

4. Slide the drive into the slot until the drive is fully seated.

See [Install a Storage Drive](#).

5. Close the drive latch to lock the drive in place.

6. Power on the server.

See [Power On the Server](#).

# 5

## Servicing Fan Modules (CRU)

This section describes how to service fan modules. Fan modules are customer-replaceable units (CRUs) that do not require you to power off the server. For more information about CRUs, see [Illustrated Parts Breakdown](#) and [Customer-Replaceable Units](#).

The fan modules are located in the front of the server. See the following procedures:

- [Remove a Fan Module](#)
- [Install a Fan Module](#)

### Related Topics

- [Remove the Server Top Cover](#)

## Remove a Fan Module

You do not have to power off the server to service the fan modules.

### **Caution:**

When removing and replacing a fan module in the Oracle Server X9-2, you must complete the entire procedure within 60 seconds to maintain adequate cooling in the system. Remove and replace only one fan module at a time. Ensure that you have obtained the replacement fan module and that it is ready for installation before starting the replacement procedure. Each fan module contains two fans, with two fan motors per fan. The four fan motors provide separate tachometer signals so that the fan module reports four tach signals to Oracle ILOM. Even if only one fan motor is faulted within the fan module, the Oracle ILOM service processor detects that four fan motors have failed to spin while the fan module is removed. If the fan module is not replaced within 60 seconds of removal, Oracle ILOM will take the protective action to shut down the system to prevent thermal damage to the system.

1. Extend the server to the maintenance position.  
See [Extend the Server to the Maintenance Position](#).
2. To access the fan modules, remove the server top cover.  
See [Remove the Server Top Cover](#).
3. Identify the faulty fan module.

Each fan module has a fan status indicator (LED) that is located on the module. If the LED is amber, the fan has failed. The location of the fan status LED is shown in the following figure.

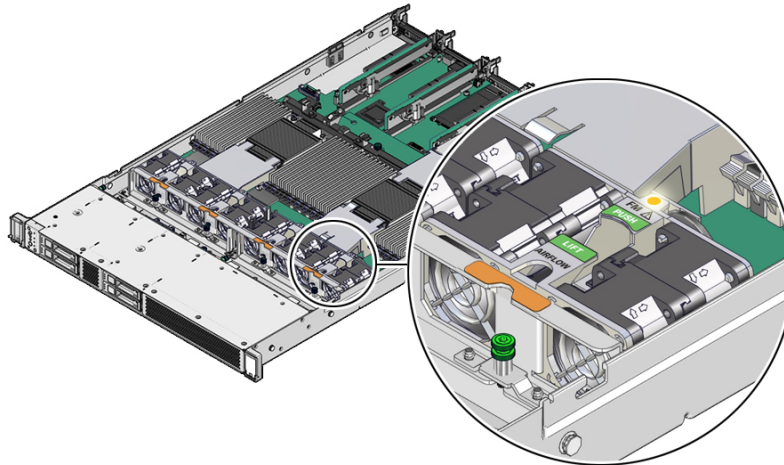

---

#### LED Color and State Meaning

---

Amber – The fan module is faulty. The front Top Fan LED and the front and back panel Fault-Service Required LEDs are also lit if the system detects a fan module fault.

---

4. Remove the faulty fan module.
  - a. Using your thumb and forefinger, grasp the fan module in the finger recesses located in the plastic between the fans.
  - b. Lift the fan module straight up and out of the chassis.

**▲ Caution:**

When removing a fan module, do not rock it back and forth. Rocking a fan module can cause damage to the motherboard connectors.

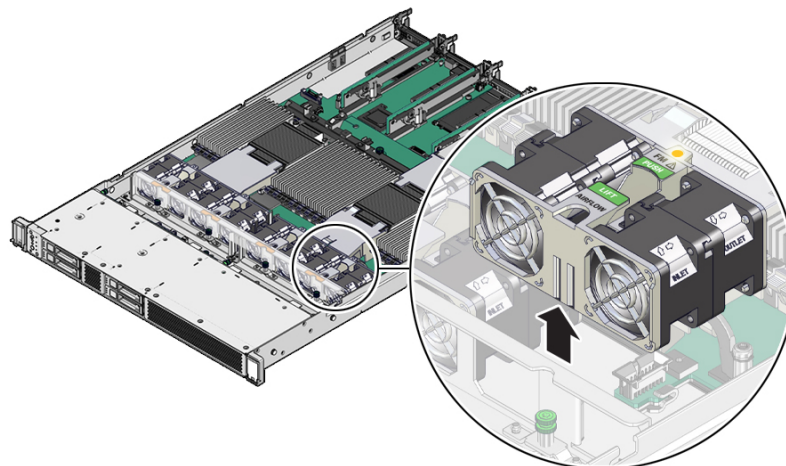

5. Set the fan module aside.

**▲ Caution:**

Do not service any other components in the fan compartment unless the system is shut down and the power cords are removed.

6. Consider your next step:
  - If you removed the fan assembly as part of another procedure, return to that procedure.
  - Otherwise, continue to [Install a Fan Module](#).

**Related Topics**

- [Install a Fan Module](#)

## Install a Fan Module

1. Remove the replacement fan module from its packaging and place it on an antistatic mat.
2. With the server top cover removed, position the replacement fan module into the server. The fan modules are keyed to ensure that they are installed in the correct orientation.

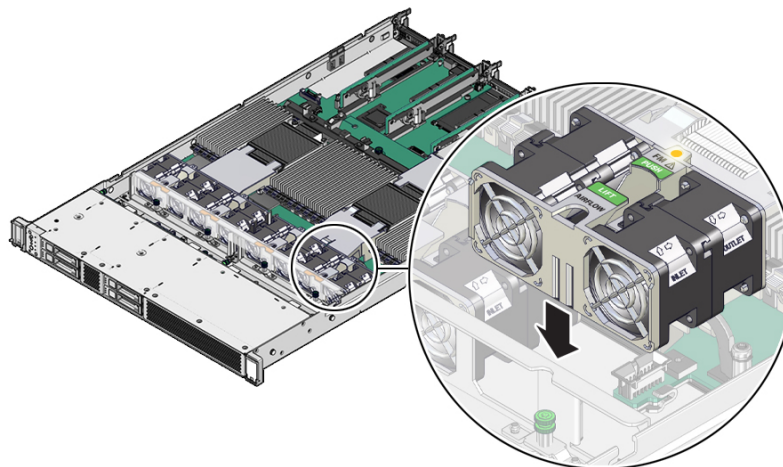

3. Press down on the fan module and apply firm pressure to fully seat the fan module.
4. Verify that the fan module status indicator (LED) that aligns with the replaced fan module is extinguished.
5. Install the server top cover.  
See [Install the Server Top Cover](#).
6. Verify that the Top Fan Fault LED on the front of the server and the Fault-Service Required LEDs on the front and back of the server are extinguished.  
See [Troubleshooting Using the Server Front and Back Panel Status Indicators](#) for more information about identifying and interpreting system indicators.
7. Consider your next step:
  - If you installed the fan module as part of another procedure, return to that procedure.

- Otherwise, return the server to operation. See [Returning the Server to Operation](#).

**Related Topics**

- [Remove a Fan Module](#)

# 6

## Servicing Power Supplies (CRU)

This section describes how to service power supplies. Power supplies are customer-replaceable units (CRUs) that do not require you to power off the server. For more information about CRUs, see [Illustrated Parts Breakdown](#) and [Customer-Replaceable Units](#).

The power supplies are located at the back of the server. See the following procedures:

- [Power Supply Overview](#)
- [Remove a Power Supply](#)
- [Install a Power Supply](#)

### Power Supply Overview

The redundant power supply in the server supports concurrent maintenance, which enables you to remove and replace a power supply without shutting down the server, if the other power supply is online and working.



#### Note:

Two hot-swappable and highly-redundant 1200W A269.2 or 1400W A271 power supplies.

Two A271 1400W power supplies or two A269 1200W power supplies are included in the base configuration. Up to two power supplies are supported. Power supplies for the system are redundant (N+N) and hot-pluggable. A271 1400W power supplies require high-line 200-240 VAC sources. Mixing A271 and A269.2 power supplies within the same chassis is not supported.

The server supports model A269.2 (1200 watt) power supplies. The A269.2 power supply unit (PSU) provides conversion from the AC lines to the system, accepting ranges from 100-240 volts AC (VAC). The PSUs are hot-pluggable, and in most cases provide fully redundant “1+1” power, allowing the system to suffer the loss of a PSU or an AC feed with no loss to system availability.

In maximally configured systems, it is possible that the worst-case power consumption of the system could exceed the capacity of a single PSU. The PSUs provide an over-subscription mode (always enabled), which allows the system to operate with fault-tolerance, even with modest excursions beyond the rated capacity of a single PSU. This over-subscription support is accomplished using hardware signaling between the PSU and motherboard circuitry, which can force the system to throttle processor (CPU) and memory power in the event that a PSU is lost. The resulting power savings is enough to allow the system to continue to run (in a lower-performance state) until the power problem is resolved.

The following status indicators (LEDs) are lit when a power supply fault is detected:



- Front and back Fault-Service Required LEDs
- Amber Fault-Service Required LED on the faulty power supply
- Rear Power Supply Fault-Service Required LED located on the server front panel

For more information, see [Power Supply Status Indicators](#).

If a power supply fails and you do not have a replacement available, leave the failed power supply installed to ensure proper airflow in the server.

#### Related Topics

- [Troubleshooting Using the Server Front and Back Panel Status Indicators](#)

## Remove a Power Supply

1. Prepare the system for power supply removal.  
See [Take Antistatic Measures](#).
2. Identify which power supply requires replacement.

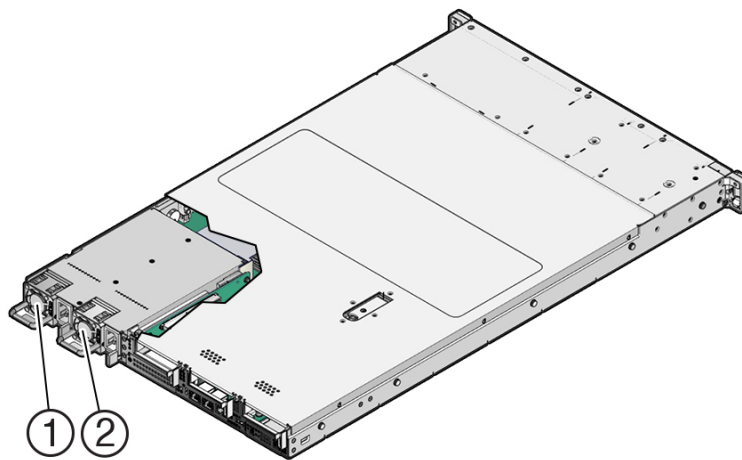

Callout	Description
1	Power supply 0
2	Power supply 1

A lit amber Fault-Service Required LED on a power supply indicates that a failure was detected. You also can use the Oracle ILOM `show faulty` command at the Oracle ILOM command line prompt (->) to identify a power supply failure.

Alternatively, to list all known faults in the server, log in to Oracle Solaris and issue the `fmadm faulty` command (Solaris root privileges required), or log in to the Oracle ILOM Fault Management Shell from the Oracle ILOM service processor and issue the `fmadm faulty` command. For more information about how to use the Oracle ILOM Fault Management Shell and supported commands, refer to the *Oracle ILOM User's Guide for System Monitoring and Diagnostics Firmware*

Release 5.0.x at [Oracle Integrated Lights Out Manager \(ILOM\) 5.0 Documentation](#).

 **Note:**

The fans of a failed power supply still might be spinning when the system is powered on. You can remove a power supply while the fans are still spinning.

3. Gain access to the rear of the server where the failed power supply is located.
4. If the cable management arm (CMA) is installed, disconnect both CMA left-side connectors and move the CMA out of the way.

Refer to *Remove the Cable Management Arm in Oracle Servers X9-2 and X9-2L Installation Guide* at [Oracle Server X9-2 Documentation](#).

 **Caution:**

When disconnecting the CMA left-side connectors, be sure to use your arm to support the CMA so that it does not hang down under its own weight and stress the right-side connectors; otherwise, the CMA might get damaged. You must continue to support the CMA until you have reconnected both left-side connectors.

5. Disconnect the power cord from the failed power supply.
6. Grasp the power supply handle and push the power supply latch to the left [1].

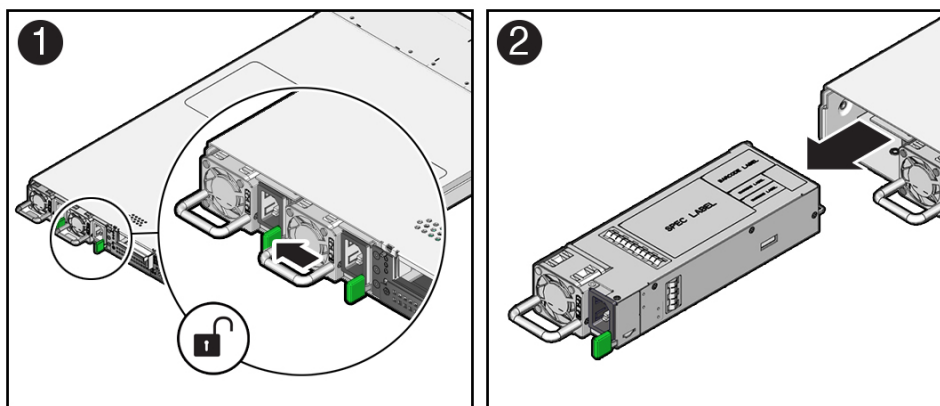

7. Pull the power supply out of the chassis [2].

 **Caution:**

When you remove a power supply, be sure to replace it with another power supply; otherwise, the server might overheat due to improper airflow.

8. Continue to Install a Power Supply.

### Related Topics

- [Back Panel Components and Cable Connections](#)
- [Power Supply Status Indicators](#)
- [Install a Power Supply](#)

## Install a Power Supply

### ▲ Caution:

Always replace a failed power supply with a power supply of the same type (model).

1. Remove the replacement power supply from its packaging and place it on an antistatic mat.
2. Align the replacement power supply with the empty power supply slot [1].
3. Slide the power supply into the bay until it is fully seated [2].  
You will hear an audible click when the power supply fully seats.

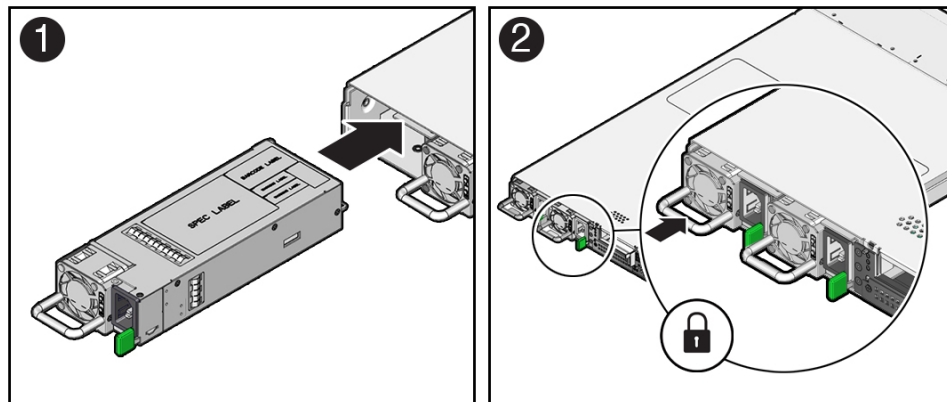

4. Reconnect the power cord to the power supply.
5. Verify that the amber Fault-Service Required LED on the replaced power supply and the Fault-Service Required LEDs on the front and back panels of the server are not lit.

 **Note:**

After you replace Power Supply 0, you must reset the Oracle ILOM service processor (SP) to propagate the key identity properties (KIP) data to the new power supply. For instructions on resetting the SP, refer to the *Oracle Integrated Lights Out Manager (ILOM) 5.0 Configuration and Maintenance Guide Firmware Release 5.0.x* at [Oracle Integrated Lights Out Manager \(ILOM\) 5.0 Documentation](#). Power Supply 1 does not contain KIP data, and therefore does not require an SP reset after replacement.

6. If you disconnected the two CMA left-side connectors, reconnect the connectors.

Refer to *Install the Cable Management Arm (Optional)* in *Oracle Servers X9-2 and X9-2L Installation Guide* at [Oracle Server X9-2 Documentation](#).

**Related Topics**

- [Back Panel Components and Cable Connections](#)
- [Power Supply Status Indicators](#)
- [Remove a Power Supply](#)

# 7

## Servicing the DIMMs (CRU)

This section describes how to service memory modules (DIMMs). DIMMs are customer-replaceable units (CRUs) that require you to power off the server. For more information about CRUs, see [Illustrated Parts Breakdown](#) and [Customer-Replaceable Units](#).

### ▲ Caution:

These procedures require that you handle components that are sensitive to electrostatic discharge. This sensitivity can cause the components to fail. To avoid damage, ensure that you follow antistatic practices as described in [Electrostatic Discharge Safety](#).

### ▲ Caution:

Ensure that all power is removed from the server before removing or installing DIMMs, or damage to the DIMMs might occur. You must disconnect all power cables from the system before performing these procedures.

The following topics and procedures provide information to assist you when replacing a DIMM or upgrading DIMMs:

- [DIMM and Processor Physical Layout](#)
- [DIMM Population Scenarios](#)
- [DIMM Population Rules](#)
- [Populating DIMMs for Optimal System Performance](#)
- [Populating DIMMs in Single-Processor Systems for Optimal System Performance](#)
- [Populating DIMMs in Dual-Processor Systems for Optimal System Performance](#)
- [DIMM Operating Speeds](#)
- [DIMM Rank Classification Labels](#)
- [Inconsistencies Between DIMM Fault Indicators and the BIOS Isolation of Failed DIMMs](#)
- [Using the Server Fault Remind Button](#)
- [Identify and Remove a DIMM](#)
- [Install a DIMM](#)

### Related Topics

- [Servicing Processors \(FRU\)](#)

## DIMM and Processor Physical Layout

Each processor, P0 and P1, has sixteen DIMM slots organized into eight memory channels. Each memory channel contains two DIMM slots: a black DIMM slot (channel slot 0) and a white DIMM slot (channel slot 1).

The physical layout of the DIMMs and processor(s) is shown in the following figure. When viewing the server from the front, processor 0 (P0) is on the left.

Memory Channels	DIMM Slot 0 (Black)	DIMM Slot 1 (White)
0	D13	D12
1	D15	D14
2	D9	D8
3	D11	D10
4	D2	D3
5	D0	D1
6	D6	D7
7	D4	D5

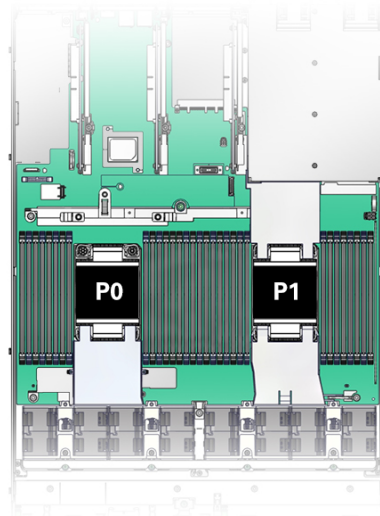

 **Note:**

In single-processor systems, the DIMM slots associated with processor 1 (P1) are nonfunctional and should not be populated with DIMMs.

**Related Topics**

- [DIMM Population Scenarios](#)
- [DIMM Population Rules](#)

- [Populating DIMMs for Optimal System Performance](#)
- [DIMM Operating Speeds](#)
- [DIMM Rank Classification Labels](#)
- [Inconsistencies Between DIMM Fault Indicators and the BIOS Isolation of Failed DIMMs](#)

## DIMM Population Scenarios

There are two scenarios in which you are required to populate DIMMs:

- A DIMM fails and needs to be replaced.  
In this scenario, you can use the Fault Remind button to determine the failed DIMM, then remove the failed DIMM and replace it. To ensure that system performance is maintained, you must replace the failed DIMM with a DIMM of the same size (in gigabytes) and type (quad-rank or dual-rank). In this scenario, you should not change the DIMM configuration.
- You have purchased new DIMMs and you want to use them to upgrade the server memory.  
In this scenario, you must adhere to the DIMM population rules and follow the recommended DIMM population order for optimal system performance.

### Related Topics

- [DIMM Population Rules](#)
- [Populating DIMMs for Optimal System Performance](#)
- [Using the Server Fault Remind Button](#)
- [Identify and Remove a DIMM](#)
- [Install a DIMM](#)

## DIMM Population Rules

The population rules for adding DIMMs to the server are as follows:

- The server supports 64-GB and 32-GB dual-rank Registered DIMMs (RDIMMs).
- Each memory channel is composed of a black slot (channel slot 0) and a white slot (channel slot 1). Populate the black slot first, and then populate the white slot.

 **Note:**

The black slot for each channel must be populated first because it is considered furthest away from the processor.

- The server supports either one DIMM per channel (1DPC) or two DIMMs per channel (2DPC).
- The server operates properly with a minimum of one DIMM installed per processor.
- The server does not support lockstep memory mode, which is also known as double device data correction, or Extended ECC.
- Mixing of single-rank and dual-rank DIMMs in Oracle Server X9-2 is not supported.

## Populating DIMMs for Optimal System Performance

Optimal performance is generally achieved by populating the DIMMs so that the memory is symmetrical, or balanced. Symmetry is achieved by adhering to the following guidelines:

- In single-processor systems, populate DIMMs of the same size in multiples of eight.
- In dual-processor systems, populate DIMMs of the same size in multiples of sixteen.
- Populate the DIMM slots in the order described in the following sections, which provide an example of how to populate the DIMM slots to achieve optimal system performance.

 **Note:**

Not all possible configurations are provided in this section.

- [Populating DIMMs in Single-Processor Systems for Optimal System Performance](#)
- [Populating DIMMs in Dual-Processor Systems for Optimal System Performance](#)

## Populating DIMMs in Single-Processor Systems for Optimal System Performance

In single-processor systems, install DIMMs only into DIMM slots associated with processor 0 (P0). Starting with slot P0 D0, first fill the black slots, and then fill the white slots, as shown in the following figure.

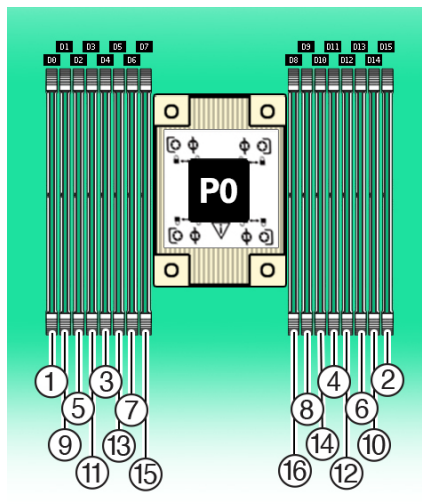



The following table describes the proper order in which to populate DIMMs in a single-processor system using the numbered callouts in the above figure, and the DIMM slot labels (D0 through D15).

Population Order	Processor/DIMM Slot
Populate black slots first in the following order:	<ol style="list-style-type: none"> <li>1. P0/D0</li> <li>2. P0/D15</li> <li>3. P0/D4</li> <li>4. P0/D11</li> <li>5. P0/D2</li> <li>6. P0/D13</li> <li>7. P0/D6</li> <li>8. P0/D9</li> </ol>
After black slots have been populated, populate white slots in the following order:	<ol style="list-style-type: none"> <li>1. P0/D1</li> <li>2. P0/D14</li> <li>3. P0/D3</li> <li>4. P0/D12</li> <li>5. P0/D5</li> <li>6. P0/D10</li> <li>7. P0/D7</li> <li>8. P0/D8</li> </ol>

## Populating DIMMs in Dual-Processor Systems for Optimal System Performance

In dual-processor systems, populate DIMMs into DIMM slots starting with processor 0 (P0) D7, alternating between slots associated with processor 0 (P0) and matching slots for processor 1 (P1). Fill the black slots, and then the white slots, as shown in the following figure.

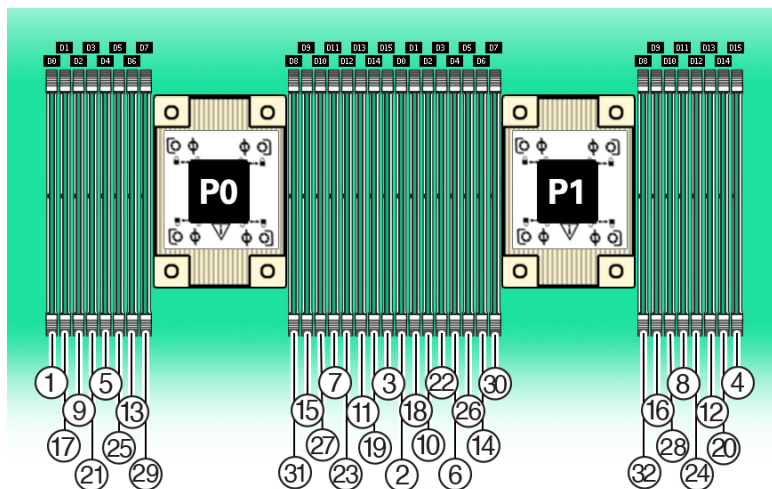

The following table describes the proper order in which to install DIMMs in a dual-processor system using the numbered callouts in the above figure, and the DIMM slot labels (D0 through D15).

Population Order	Processor/DIMM Slot
Populate black slots first in the following order:	1. P0/D0
	2. P1/D0
	3. P0/D15
	4. P1/D15
	5. P0/D4
	6. P1/D4
	7. P0/D11
	8. P1/D11
	9. P0/D2
	10. P1/D2
	11. P0/D13
	12. P1/D13
	13. P0/D6
	14. P1/D6
	15. P0/D9
	16. P1/D9

Population Order	Processor/DIMM Slot
After black slots have been populated, populate white slots in the following order:	1. P0/D1
	2. P1/D1
	3. P0/D14
	4. P1/D14
	5. P0/D3
	6. P1/D3
	7. P0/D12
	8. P1/D12
	9. P0/D5
	10. P1/D5
	11. P0/D10
	12. P1/D10
	13. P0/D7
	14. P1/D7
	15. P0/D8
	16. P1/D8

The DIMM population for each processor (P0 and P1) must be identical.

**Table 7-1 DIMM Memory Slot Population Requirements**

DIMMs per CPU	Channel Population Order	DIMM Memory Slots CPU-0/1
16 DIMMs per CPU	Number Installed	D0 D1 D2 D3 D4 D5 D6 D7 D8 D9 D10 D11 D12 D13 D14 D15 X X X X X X X X X X X X X X X X
12 DIMMs per CPU	Number Installed	D0 D1 D2 D3 D4 D5 D6 D7 D8 D9 D10 D11 D12 D13 D14 D15 X X X X X X E E E E X X X X X X
8 DIMMs per CPU	Number Installed	D0 D1 D2 D3 D4 D5 D6 D7 D8 D9 D10 D11 D12 D13 D14 D15 X E X E X E X E E X E X E X E X
6 DIMMs per CPU	Number Installed	D0 D1 D2 D3 D4 D5 D6 D7 D8 D9 D10 D11 D12 D13 D14 D15 X E X E X E E E E E E X E X E X

**Table 7-1 (Cont.) DIMM Memory Slot Population Requirements**

DIMMs per CPU	Channel Population Order	DIMM Memory Slots CPU-0/1
4 DIMMs per CPU	Number Installed	D0 D1 D2 D3 D4 D5 D6 D7 D8 D9 D10 D11 D12 D13 D14 D15 X E E E X E E E E E E X E E E X
2 DIMMs per CPU	Number Installed	D0 D1 D2 D3 D4 D5 D6 D7 D8 D9 D10 D11 D12 D13 D14 D15 X E E E E E E E E E E E E E E E
1 DIMM per CPU	Number Installed	D0 D1 D2 D3 D4 D5 D6 D7 D8 D9 D10 D11 D12 D13 D14 D15 X E E E E E E E E E E E E E E E

## DIMM Operating Speeds

The maximum supported memory speed is 3200 MT/s. However, not all system configurations support operation at this speed. The maximum attainable memory speed is limited by the maximum speed supported by the specific type of processor. All memory installed in the system operates at the same speed, or frequency.

## DIMM Rank Classification Labels

DIMMs come in a variety of ranks: dual or quad. Each DIMM is shipped with a label identifying its rank classification. The following table identifies the label corresponding to each DIMM rank classification:

**Table 7-2 DIMM Rank Classification Labels**

Rank Classification	Label
Quad-rank LRDIMM	4Rx4
Dual-rank RDIMM	2Rx4

## Inconsistencies Between DIMM Fault Indicators and the BIOS Isolation of Failed DIMMs

When a single DIMM is marked as failed by Oracle ILOM (for example, `fault.memory.intel.dimm.training-failed` is listed in the service processor Oracle ILOM event log), BIOS might disable the entire memory channel that contains the failed DIMM, up to two DIMMs. As a result, none of the memory installed in the disabled channel is available to the operating system. However, when the Fault Remind button is pressed, only the fault status indicator (LED) associated with the

failed DIMM lights. The fault LEDs for the other DIMMs in the memory channel remain off. Therefore, you can correctly identify the failed DIMM using the lit LED.

## Using the Server Fault Remind Button

When the server Fault Remind button [1] is pressed, an LED located next to the Fault Remind button lights green to indicate that there is sufficient voltage present in the fault remind circuit to light any fault LEDs that were lit due to a component failure. If this LED does not light when you press the Fault Remind button, it is likely that the capacitor powering the fault remind circuit has lost its charge. This can happen if the Fault Remind button is pressed for several minutes with fault LEDs lit or if power has been removed from the server for more than 15 minutes.

The following figure shows the location of the Fault Remind button.

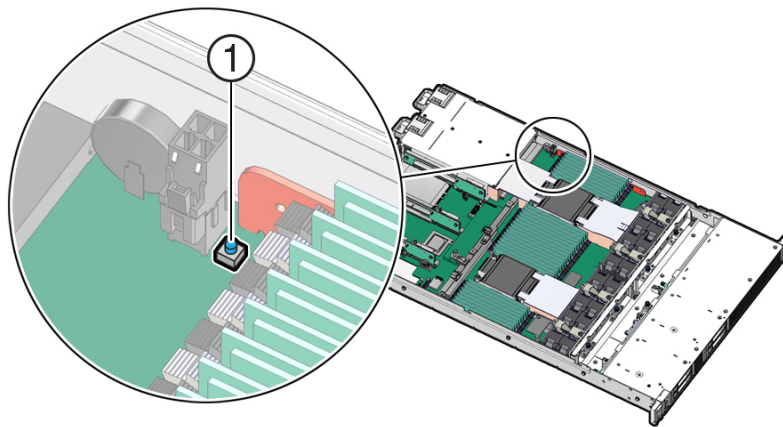

## Identify and Remove a DIMM

1. Prepare the server for service.
  - a. Power off the server, and disconnect the power cords from the power supplies.  
See [Powering Down the Server](#).
  - b. Extend the server to the maintenance position.  
See [Extend the Server to the Maintenance Position](#).
  - c. Attach an antistatic wrist strap to your wrist and then to a metal area on the chassis.  
See [Take Antistatic Measures](#).
  - d. Remove the server top cover.  
See [Remove the Server Top Cover](#).
2. Identify and note the location of the failed DIMM by pressing the Fault Remind button on the motherboard.  
See [Using the Server Fault Remind Button](#).  
Failed DIMMs are identified with a corresponding amber LED on the motherboard.

- If the DIMM Fault LED is off, then the DIMM is operating properly.
- If the DIMM Fault LED is on (amber), then the DIMM is failed and must be replaced [1].

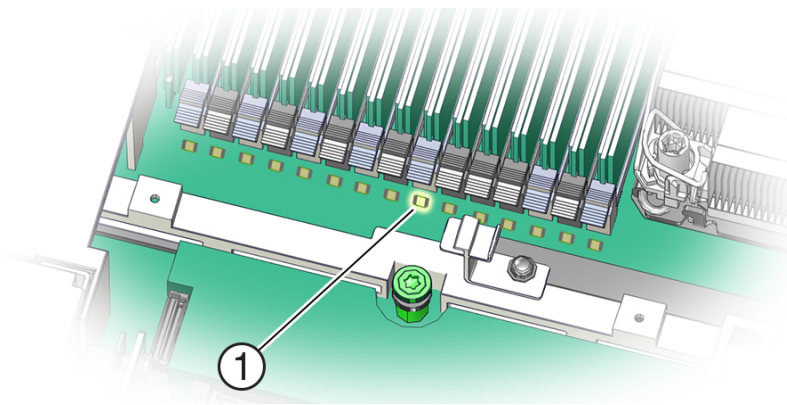

3. To remove the failed DIMM do the following:
  - a. Rotate both DIMM slot ejectors outward as far as they go.  
The DIMM is partially ejected from the slot.
  - b. Carefully lift the DIMM straight up to remove it from the slot.

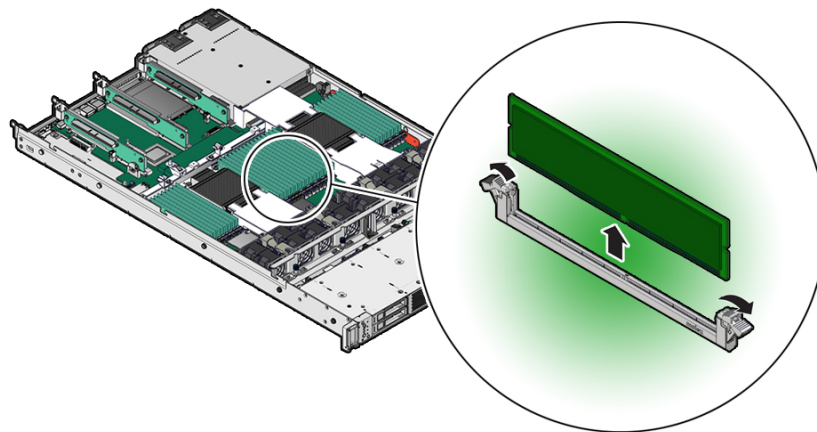

4. Replace each failed DIMM with either another DIMM of the same rank size (quad-rank or dual-rank) or leave the slot empty.

For DIMM replacement instructions, see [Install a DIMM](#).

#### Related Topics

- [DIMM and Processor Physical Layout](#)
- [DIMM Population Rules](#)
- [Populating DIMMs for Optimal System Performance](#)
- [Install a DIMM](#)

## Install a DIMM

1. Unpack the replacement DIMM and place it on an antistatic mat.
2. Ensure that the replacement DIMM matches the size, type, and rank of the DIMM it is replacing.

**▲ Caution:**

You must not replace a dual-rank DIMM with a quad-rank DIMM and vice versa. If you violate this rule, the performance of the server might be adversely affected. For DIMM slot population rules, see [DIMM Population Rules](#).

3. Install a DIMM.
  - a. Ensure that the ejector tabs are in the open position.
  - b. Align the notch in the replacement DIMM with the connector key in the connector slot. The notch ensures that the DIMM is oriented correctly.
  - c. Push the DIMM into the connector slot until the ejector tabs lock the DIMM in place. If the DIMM does not easily seat into the connector slot, verify that the notch in the DIMM is aligned with the connector key in the connector slot.

**▲ Caution:**

If the notch is not aligned, damage to the DIMM might occur.

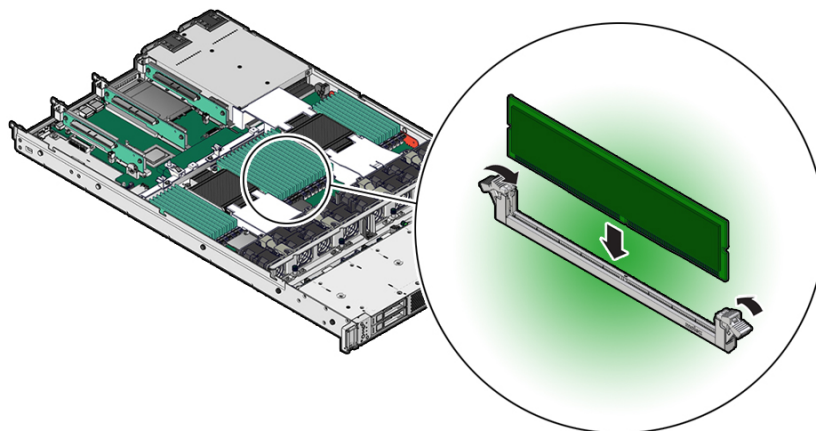

4. Repeat [Step 3](#) until all replacement DIMMs are installed.
5. Return the server to operation.
  - a. Install the server top cover. See [Install the Server Top Cover](#).

- b. Return the server to the normal rack position.  
See [Return the Server to the Normal Rack Position](#).
  - c. Reconnect the power cords to the server power supplies and reconnect the data cables.  
See [Reconnect Data Cables and Power Cords](#).
  - d. Power on the server.  
See [Power On the Server](#).
  - e. Verify that the power supply AC OK LED is lit.
6. (Optional) Use Oracle ILOM to clear server DIMM faults.
- DIMM faults are automatically cleared after a new DIMM has been installed. If you need to manually clear DIMM faults, refer to [Oracle Integrated Lights Out Manager \(ILOM\) 5.0 Documentation](#).

 **Note:**

If you want to move a failed DIMM to a new DIMM slot or re-seat a DIMM for troubleshooting, you must first manually clear the associated DIMM fault. Otherwise, the DIMM fault might follow the DIMM to the new slot location or reoccur in the current slot location, causing a false DIMM fault condition.

**Related Topics**

- [DIMM and Processor Physical Layout](#)
- [DIMM Population Rules](#)
- [Populating DIMMs for Optimal System Performance](#)
- [Identify and Remove a DIMM](#)



# 8

## Servicing PCIe Risers (CRU)

This section describes how to service PCIe risers. PCIe risers are customer-replaceable units (CRUs) that require you to power off the server. For more information about CRUs, see [Illustrated Parts Breakdown](#) and [Customer-Replaceable Units](#).

PCIe cards in all slots are installed on vertical risers. You must remove the associated riser to remove and replace a PCIe card. You must remove all three PCIe risers when replacing the motherboard.

### ▲ Caution:

These procedures require that you handle components that are sensitive to electrostatic discharge. This sensitivity can cause the components to fail. To avoid damage, ensure that you follow antistatic practices as described in [Electrostatic Discharge Safety](#).

### ▲ Caution:

Ensure that all power is removed from the server before removing or installing PCIe risers, or damage to the PCIe cards installed in the risers might occur. You must disconnect all power cables from the system before performing these procedures.

The following sections provide information to assist you in servicing PCIe risers:

- [PCIe Riser Locations](#)
- [Remove a PCIe Riser](#)
- [Install a PCIe Riser](#)

### Related Topics

- [Servicing PCIe Cards \(CRU\)](#)

## PCIe Riser Locations

There are three PCIe risers available for PCIe cards. The following figure shows the PCIe riser numbers and locations.

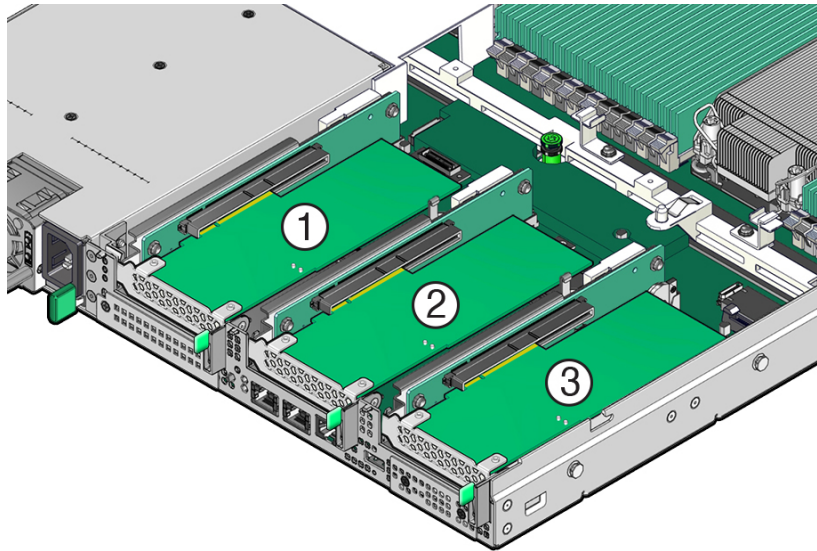

Callout	Description
1	PCIe riser with installed PCIe card in slot 1 (This slot is nonfunctional in single-processor systems.)
2	PCIe riser with installed PCIe card in slot 2
3	PCIe riser with installed PCIe card in slot 3.

#### Related Topics

- [PCIe Slot Locations](#)

## Remove a PCIe Riser



#### Note:

PCIe slot 1 is nonfunctional in single-processor systems.

1. Prepare the server for service.
  - a. Power off the server and disconnect the power cords from the power supplies.  
See [Powering Down the Server](#).
  - b. Extend the server to the maintenance position.  
See [Extend the Server to the Maintenance Position](#).
  - c. Attach an antistatic wrist strap to your wrist and then to a metal area on the chassis.  
See [Take Antistatic Measures](#).
  - d. Remove the server top cover.  
See [Remove the Server Top Cover](#).

2. Select the PCIe riser that you want to remove.  
See [PCIe Slot Locations](#).
3. If a PCIe card is installed in the riser, disconnect any external cables from the card.
4. Lift the green-tabbed latch on the rear of the server chassis next to the applicable PCIe slot to release the rear bracket on the PCIe card [1].

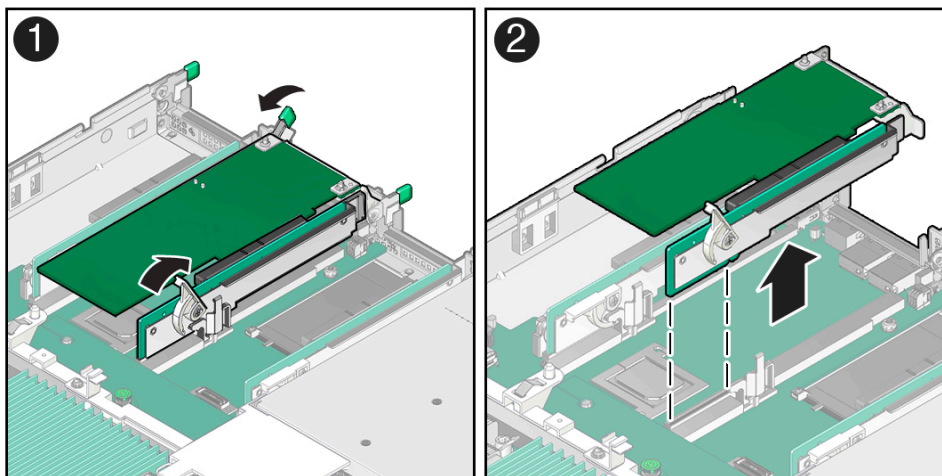

 **Note:**

If the riser does not have a PCIe card installed, lift the latch to release the PCIe slot filler panel.

5. Lift the green-tabbed riser release lever on the PCIe riser with one hand and use your other hand to remove the riser from the motherboard connector [1, 2].
6. If there is a PCIe card installed in the riser, place the riser on an antistatic mat and note the slot in which the PCIe riser was originally installed; otherwise, set the PCIe riser aside.

**Related Topics**

- [Install a PCIe Riser](#)
- [Install a PCIe Card](#)

## Install a PCIe Riser

 **Note:**

PCIe slot 1 is nonfunctional in single-processor systems.

1. Determine into which slot you will install the PCIe riser.
2. Retrieve the PCIe riser and any PCIe cards attached to it.

3. Raise the green-tabbed release lever on the PCIe riser to the open (up) position [1].
4. Gently press the riser into the motherboard connector until it is seated, and then press the green-tabbed release lever on the PCIe riser to the closed (down) position [1, 2].

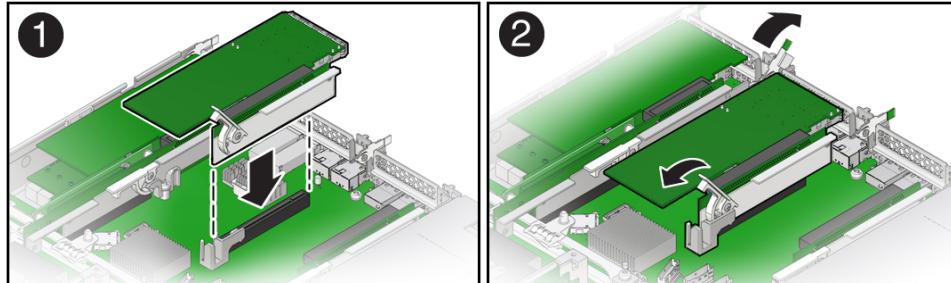

5. Close the green-tabbed latch on the rear of the server chassis next to the applicable PCIe slot to secure the rear bracket on the PCIe card to the server chassis [2].

 **Note:**

If the riser does not have a PCIe card installed, install a PCIe slot filler panel and close the green-tabbed latch to secure the filler panel.

6. If there were any external cables connected to the PCIe card, reconnect them.
7. Return the server to operation.
  - a. Install the server top cover.  
See [Install the Server Top Cover](#).
  - b. Return the server to the normal rack position.  
See [Return the Server to the Normal Rack Position](#).
  - c. Reconnect the power cords to the server power supplies and reconnect the data cables.  
See [Reconnect Data Cables and Power Cords](#).
  - d. Power on the server.  
See [Power On the Server](#).
  - e. Verify that the System OK status indicator is steady on.

8. Use Oracle ILOM to clear the server PCIe riser fault.

If the PCIe riser fault message in Oracle ILOM is not cleared under Open Problems, you must manually clear the fault in Oracle ILOM. Refer to "Clear Faults for Undetected Replaced or Repaired Hardware Components" in the *Oracle ILOM User's Guide for System Monitoring and Diagnostics Firmware Release 5.0.x* at [Oracle Integrated Lights Out Manager \(ILOM\) 5.0 Documentation](#).

**Related Topics**

- [Remove a PCIe Riser](#)

- [Remove a PCIe Card](#)

# 9

## Servicing PCIe Cards (CRU)

This section describes how to service PCIe cards. PCIe cards are customer-replaceable units (CRUs) that require you to power off the server. For more information about CRUs, see [Illustrated Parts Breakdown](#) and [Customer-Replaceable Units](#).

### **Caution:**

These procedures require that you handle components that are sensitive to electrostatic discharge. This sensitivity can cause the components to fail. To avoid damage, ensure that you follow antistatic practices as described in [Electrostatic Discharge Safety](#).

### **Caution:**

Ensure that all power is removed from the server before removing or installing PCIe cards. You must disconnect all power cables from the system before performing these procedures.

### **Note:**

For a complete list of supported PCIe cards, refer to the *Oracle Server X9-2 Product Notes* at [Oracle Server X9-2 Documentation](#).

This section covers the following topics and procedures:

- [PCIe Slot Locations](#)
- [Remove a PCIe Card](#)
- [Install a PCIe Card](#)

#### **Related Topics**

- [Servicing PCIe Risers \(CRU\)](#)

## PCIe Slot Locations

There are three PCIe slots available for PCIe cards. The following figure shows the PCIe slot numbering.

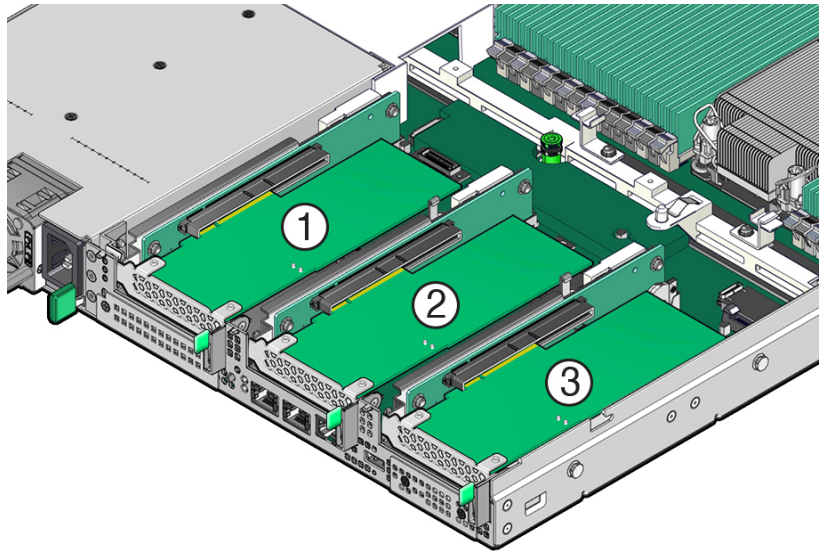

Call Out	Description
1	PCIe slot 1 (Nonfunctional in single-processor systems.)
2	PCIe slot 2
3	PCIe slot 3

 **Note:**

All of the PCIe slots comply with the PCI Express 4.0 specification and can accommodate 75 Watt PCIe cards.

**Related Topics**

- [Back Panel Components and Cable Connections](#)

## Remove a PCIe Card

 **Note:**

PCIe slot 1 is nonfunctional in single-processor systems.

 **Note:**

Before replacing or installing a PCIe card, refer to the card documentation for specific installation and cabling instructions.

1. Remove the PCIe riser from the server.

See [Remove a PCIe Riser](#).

2. Remove the PCIe card from the PCIe riser.
  - Hold the riser in one hand and use your other hand to carefully pull the PCIe card connector out of the riser.

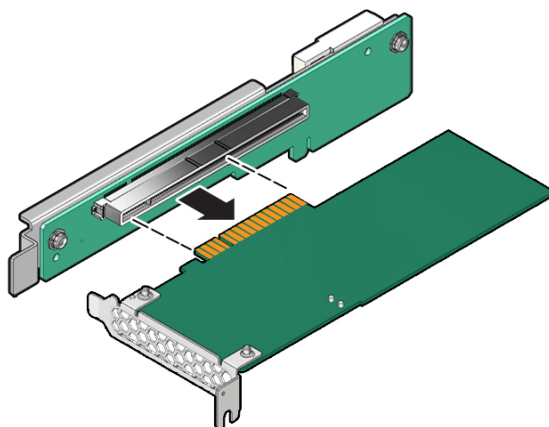

3. Place the PCIe card on an antistatic mat.

**⚠ Caution:**

Whenever you remove a PCIe card, you should replace it with another PCIe card or a PCIe filler panel. Installing PCIe filler panels in vacant PCIe slots helps reduce the level of electromagnetic interference (EMI) emitted by the server and provides proper airflow across all server components. See [Remove and Install Filler Panels](#).

## Install a PCIe Card

**✎ Note:**

PCIe slot 1 is nonfunctional in single-processor systems.

1. Retrieve the PCIe card and riser you want to install.
2. Install the PCIe card into the PCIe riser.
  - Hold the riser in one hand and use your other hand to carefully insert the PCIe card connector into the riser.



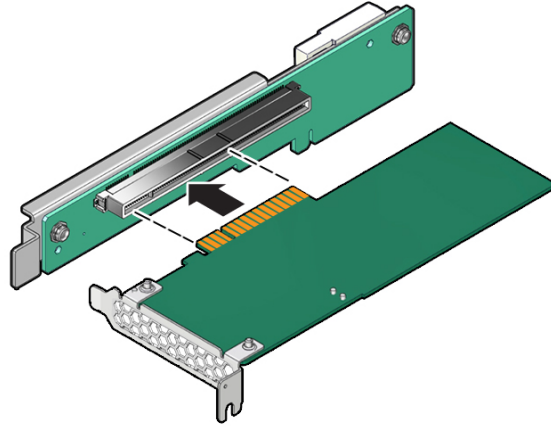

3. Install the PCIe riser into the server.  
See [Install a PCIe Riser](#).

# 10

## Servicing the Internal M.2 Flash SSDs (CRU)

This section describes how to service M.2 flash solid-state drives (SSDs). M.2 flash SSDs are customer-replaceable units (CRUs) that require you to power off the server. For more information about CRUs, see [Illustrated Parts Breakdown](#) and [Customer-Replaceable Units](#).

### ▲ Caution:

These procedures require that you handle components that are sensitive to electrostatic discharge. This sensitivity can cause the component to fail. To avoid damage, ensure that you follow antistatic practices as described in [Electrostatic Discharge Safety](#).

### ▲ Caution:

Ensure that all power is removed from the server before removing or installing M.2 flash SSDs. You must disconnect all power cables from the system before performing these procedures.

This section covers the following procedures:

- [Remove an M.2 Mezzanine](#)
- [Install an M.2 Mezzanine](#)
- [Remove an M.2 Flash SSD](#)
- [Install an M.2 Flash SSD](#)

### Related Topics

- [Servicing Storage Drives \(CRU\)](#)

## Remove an M.2 Mezzanine

1. Prepare the server for service.
  - a. Power off the server and disconnect the power cords from the power supplies.  
See [Powering Down the Server](#).
  - b. Extend the server to the maintenance position.  
See [Extend the Server to the Maintenance Position](#).
  - c. Attach an antistatic wrist strap to your wrist and then to a metal area on the chassis.  
See [Take Antistatic Measures](#).
  - d. Remove the server top cover.

See [Remove the Server Top Cover](#).

2. Remove the M.2 mezzanine containing the M.2 flash SSDs from the server.
  - a. Using a T15 Torx screwdriver, loosen the two captive SSSDR screws that secure the M.2 mezzanine to the mid wall chassis stiffener [1].

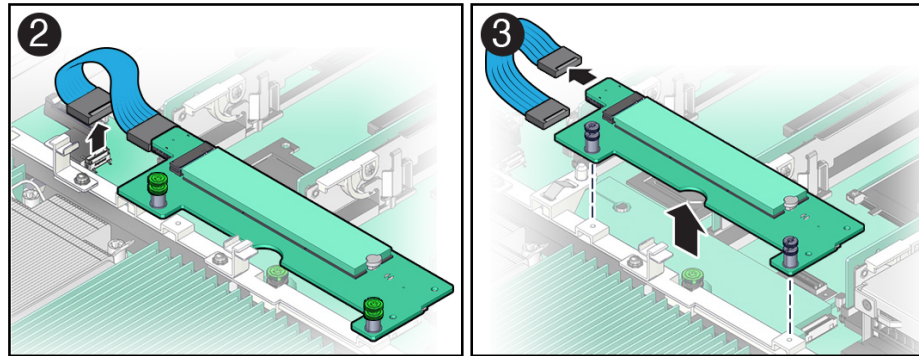
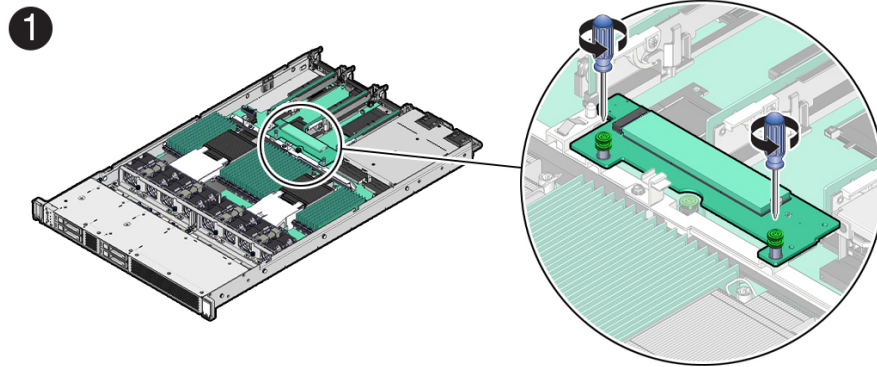

- b. Disconnect the SATA/PCIe data cable from the motherboard [2].
    - c. Lift the M.2 mezzanine straight up and out of the server to disconnect the mezzanine SSSDR power connector from the motherboard SSSDR power connector [3].
    - d. (Optional) Disconnect the SATA/PCIe data cable from the M.2 mezzanine [3].

 **Note:**

You do not need to disconnect the SATA/PCIe data cable from the mezzanine if you are servicing only the M.2 flash SSDs.

- e. Place the M.2 mezzanine on an antistatic mat. If required, perform the procedures for removing the M.2 flash SSDs from the mezzanine.

See [Remove an M.2 Flash SSD](#).

**Related Topics**

- [Install an M.2 Mezzanine](#)

## Install an M.2 Mezzanine

1. Unpack the replacement M.2 mezzanine and place it on an antistatic mat.  
If required, ensure that you have installed the M.2 flash SSDs on to the M.2 mezzanine before installing the mezzanine in the server. See [Install an M.2 Flash SSD](#).
2. Install the M.2 mezzanine containing the M.2 flash SSDs in the server.
  - a. (Optional) Reconnect the SATA/PCIe data cable to the M.2 mezzanine [1].

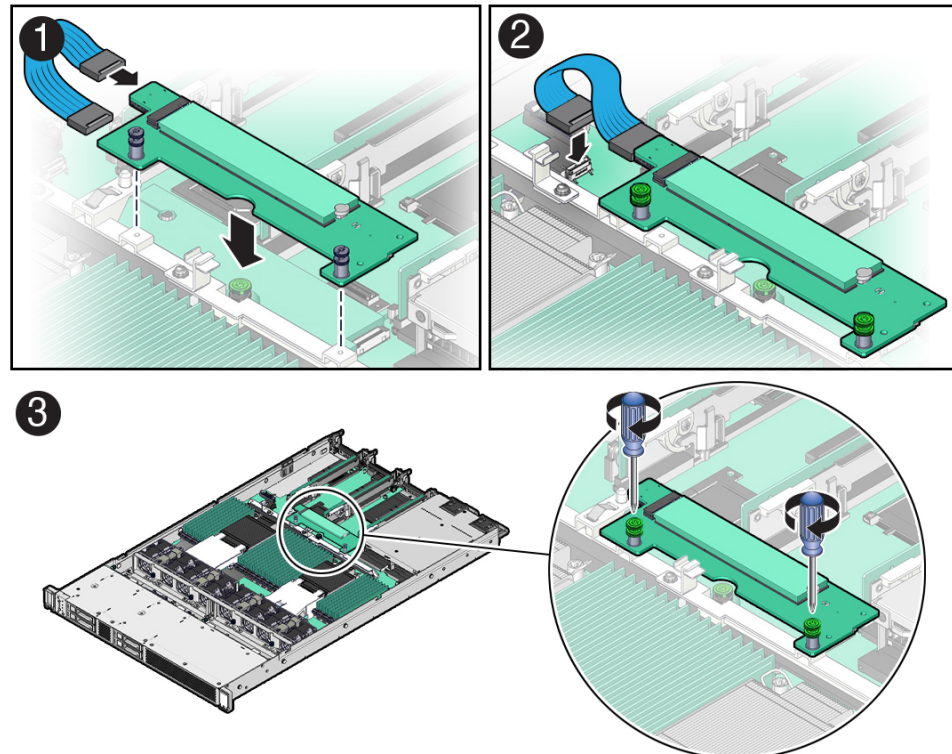

- b. Align the M.2 mezzanine with the SSSDR screw holds and the motherboard SSSDR power connector, then lower the M.2 mezzanine straight down in to the server to connect the mezzanine and motherboard SSSDR power connectors [2].
  - c. Reconnect the SATA/PCIe data cable to the motherboard [2].
  - d. Using a T15 Torx screwdriver, tighten the two captive SSSDR screws to secure the M.2 mezzanine to the chassis mid wall [3].
3. Return the server to operation.
    - a. Install the server top cover.  
See [Install the Server Top Cover](#).
    - b. Return the server to the normal rack position.  
See [Return the Server to the Normal Rack Position](#).
    - c. Reconnect the power cords to the server power supplies and reconnect the data cables.

See [Reconnect Data Cables and Power Cords](#).

- d. Power on the server.  
See [Power On the Server](#).
- e. Verify that the System OK status indicator is steady on.

#### Related Topics

- [Remove an M.2 Mezzanine](#)

## Remove an M.2 Flash SSD

1. Perform the steps to remove the M.2 mezzanine containing the M.2 flash SSDs.  
See [Remove an M.2 Mezzanine](#). Place the M.2 mezzanine on an antistatic mat.
2. Using your fingers, push the plastic retainer clip through the M.2 mezzanine to release the M.2 flash SSD from the mezzanine. [1].

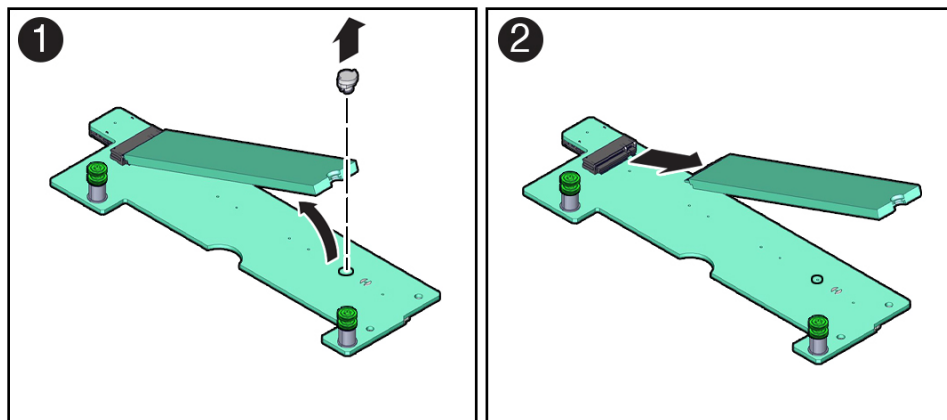

3. Remove the plastic retainer clip from the M.2 flash SSD.
4. Remove the M.2 flash SSD from the mezzanine [2].
  - a. Lift up on the end of the M.2 flash SSD where the plastic retainer clip was removed by one-half to one inch.
  - b. Gently slide the M.2 flash SSD card rearward and out of the connector to disengage the SSD contacts from the mezzanine socket.
  - c. Place the M.2 flash SSD on an antistatic mat.
5. Repeat [Step 2](#) through [Step 4](#) to remove the second M.2 flash SSD from the opposite side of the M.2 mezzanine.

#### Related Topics

- [Install an M.2 Flash SSD](#)

# Install an M.2 Flash SSD

 **Note:**

The M.2 mezzanine contains two M.2 flash SSD sockets (labeled SSD0 and SSD1). If you are installing a single M.2 flash SSD on to the mezzanine, install the M.2 flash SSD into socket SSD0.

1. Unpack the replacement M.2 flash SSD.
2. Install the M.2 flash SSD.
  - a. Align and then insert the plastic retainer clip into the slot on the M.2 flash SSD.
  - b. Hold the M.2 flash SSD so that the end of the card containing the plastic retainer clip is approximately one-half to one inch above the M.2 mezzanine and the other end is adjacent to the mezzanine SSD socket [1].

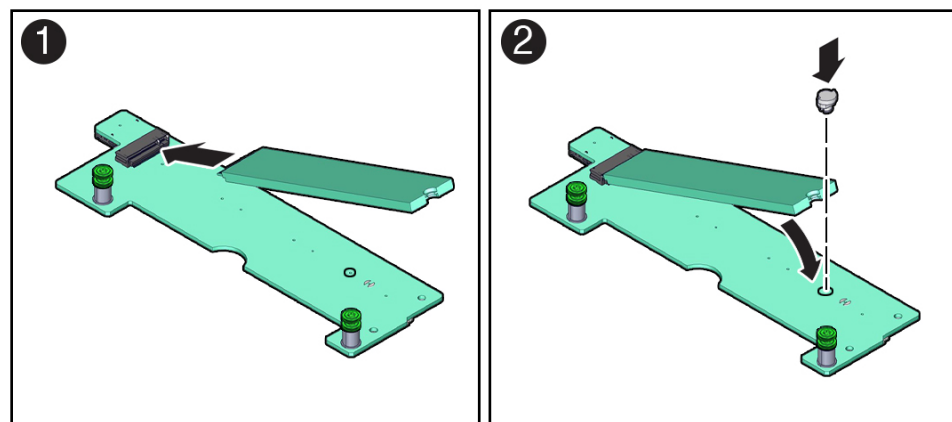

- c. Gently slide the M.2 flash SSD forward and into the connector to engage the flash SSD contacts with the M.2 mezzanine socket [2].
  - d. Using your fingers, push down on the end of the card containing the plastic retainer clip until the M.2 flash SSD snaps into place on the mezzanine [2].

You will hear an audible click when the M.2 flash SSD is secured to the mezzanine.
3. Repeat [Step 2](#) to install the second M.2 flash SSD on to the opposite side of the M.2 mezzanine.
  4. Perform the steps to install the M.2 mezzanine with the replacement M.2 flash SSDs in the server.

See [Install an M.2 Mezzanine](#).

## Related Topics

- [Remove an M.2 Flash SSD](#)

# 11

## Servicing the Battery (CRU)

This section describes how to service the system battery. The system battery is a customer-replaceable unit (CRU) that requires you to power off the server. For more information about CRUs, see [Illustrated Parts Breakdown](#) and [Customer-Replaceable Units](#).

The real-time clock (RTC) battery maintains system time when the server is powered off and a time server is unavailable. If the server fails to maintain the proper time when the system is powered off and not connected to a network, replace the battery.

### ▲ Caution:

These procedures require that you handle components that are sensitive to electrostatic discharge. This sensitivity can cause the components to fail. To avoid damage, ensure that you follow antistatic practices as described in [Electrostatic Discharge Safety](#).

### ▲ Caution:

Ensure that all power is removed from the server before removing or installing the battery. You must disconnect the power cables from the system before performing this procedure.

This section covers the following procedures:

- [Remove the Battery](#)
- [Install the Battery](#)

### Related Topics

- [Extend the Server to the Maintenance Position](#)
- [Remove the Server Top Cover](#)

## Remove the Battery

1. Prepare the server for service.
  - a. Power off the server and disconnect the power cords from the power supplies.  
See [Powering Down the Server](#).
  - b. Extend the server to the maintenance position.  
See [Extend the Server to the Maintenance Position](#).
  - c. Attach an antistatic wrist strap to your wrist and then to a metal area on the chassis.

- See [Take Antistatic Measures](#).
- d. Remove the server top cover.  
See [Remove the Server Top Cover](#).
2. To dislodge the battery from its retainer, use your finger to gently push the top edge of the battery away from the retainer.

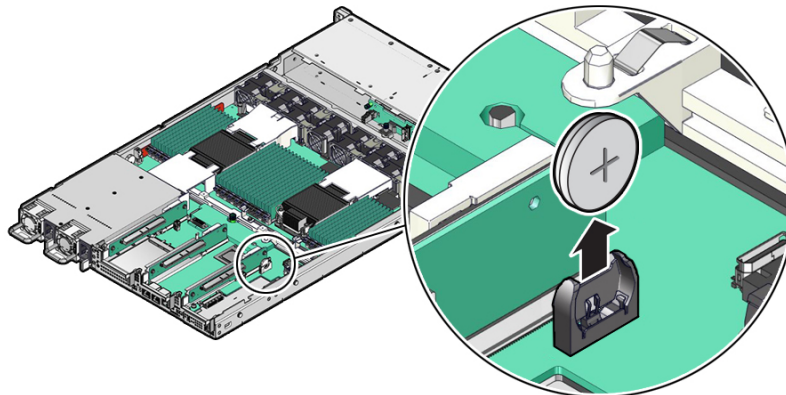

## Install the Battery

1. Unpack the replacement battery.
2. Press the new battery into the battery retainer.
3. Return the server to operation.
  - a. Install the server top cover.  
See [Install the Server Top Cover](#).
  - b. Return the server to the normal rack position.  
See [Return the Server to the Normal Rack Position](#).
  - c. Reconnect the power cords to the server power supplies and reconnect the data cables.  
See [Reconnect Data Cables and Power Cords](#).
  - d. Power on the server.  
See [Power On the Server](#).
  - e. Verify that the System OK LED indicator is lit.

 **Note:**

If the service processor is configured to synchronize with a network time server using the Network Time Protocol (NTP), the Oracle ILOM SP clock is reset as soon as the server is powered on and connected to the network. Otherwise, proceed to the next step.

4. If the service processor is not configured to use NTP, do one of the following:



- Reset the Oracle ILOM clock using the Oracle ILOM CLI or the web interface.  
Refer to the Oracle Integrated Lights Out Manager (ILOM) 5.0 Documentation Library at [Oracle Integrated Lights Out Manager \(ILOM\) 5.0 Documentation](#).
- Use the BIOS Setup Utility to reprogram the host clock.  
Refer to the *Oracle X9 Series Servers Administration Guide* at [Oracle x86 Servers Administration, Diagnostics, and Applications Documentation](#).

# 12

## Servicing Processors (FRU)

The following section describes how to service processors. Processors are field-replaceable units (FRUs). For more information about FRUs, see [Illustrated Parts Breakdown](#) and [Field-Replaceable Units](#).

### **Caution:**

Processors must be removed and replaced only by authorized Oracle Service personnel.

### **Caution:**

Ensure that all power is removed from the server before removing or installing a processor. You must disconnect the power cables from the system before performing these procedures.

### **Caution:**

These procedures require that you handle components that are sensitive to electrostatic discharge. This sensitivity can cause the component to fail. To avoid damage, ensure that you follow electrostatic discharge safety measures and antistatic practices. See [Electrostatic Discharge Safety](#).

### **Note:**

On single-processor systems, processor socket 1 (P1) is shipped without a heatsink and processor filler cover. To protect the delicate processor socket pins, do not remove the processor cover that was installed on the motherboard.

This section covers the following topics:

- [Identify and Remove a Processor](#)
- [Install a Processor](#)

### **Related Topics**

- [Servicing the DIMMs \(CRU\)](#)

## Identify and Remove a Processor

### ▲ Caution:

Whenever you remove a processor, replace it with another processor and reinstall the processor heatsink; otherwise, the server might overheat due to improper airflow. See [Install a Processor](#).

- Use an antistatic wrist strap and a work space with an antistatic mat. See [Electrostatic Discharge Safety](#).
- Use ESD (not latex or vinyl) gloves, if possible, when handling the processor.
- Be careful not to touch the processor socket pins.

### ▲ Caution:

The processor socket pins are very fragile. A light touch can bend the processor socket pins beyond repair.

- Obtain a medium flat blade screwdriver
  - Obtain a T30 Torx driver or bit
1. Prepare the server for service.
    - a. Power off the server and disconnect the power cords from the power supplies. See [Powering Down the Server](#).
    - b. Extend the server to the maintenance position. See [Extend the Server to the Maintenance Position](#).
    - c. Attach an antistatic wrist strap to your wrist, and then to a metal area on the chassis. See [Take Antistatic Measures](#).
    - d. Remove the server top cover. See [Remove the Server Top Cover](#).
    - e. Lift the P0, P1, and power supply air baffles up and out of the server and set them aside.
  2. Identify the location of the failed processor by pressing the Fault Remind button on the motherboard. Fault Remind button identifying failed processors buttons Fault Remind Fault Remind button location processors identifying faulty processor fault identification processors processors Fault Remind button

 **Note:**

When you press the Fault Remind button, an LED located next to the Fault Remind button lights green, which indicates that there is sufficient voltage in the fault remind circuit to light any fault LEDs that were lit due to a failure. If this LED fails to light when you press the Fault Remind button, it is likely that the capacitor powering the fault remind circuit lost its charge. This can happen if you press the Fault Remind button for a long time with fault LEDs lit, or if power was removed from the server for more than 15 minutes.

The processor fault LED for the failed processor lights. The processor fault LEDs are located next to the processors. See [Motherboard Status Indicators](#).

- If the processor fault LED is off, the processor is operating properly.
- If the processor fault LED is on (amber), the processor failed and must be replaced.

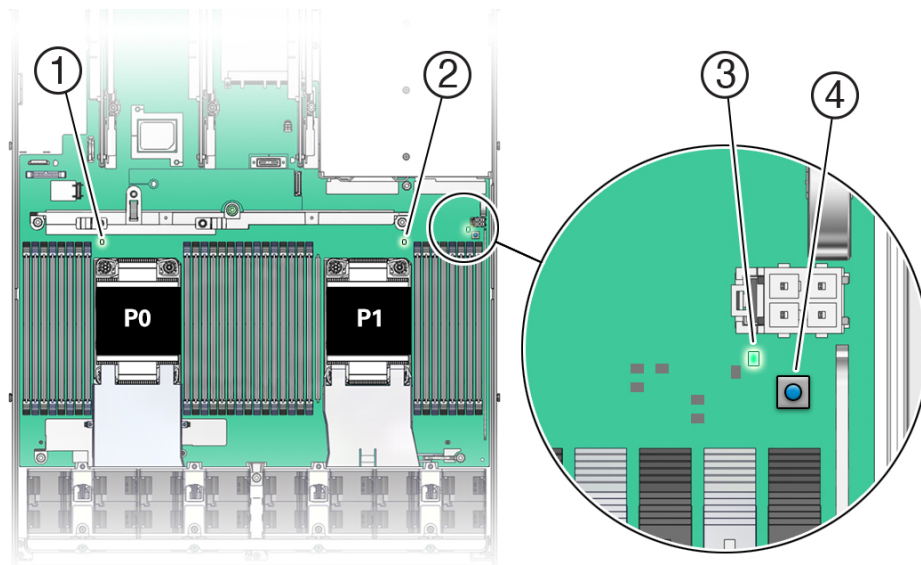

Callout	Description
1	Processor 0 fault LED
2	Processor 1 fault LED
3	Fault Remind Circuit Good LED
4	Fault Remind button

3. Using a Torx T30 screwdriver, loosen the four captive load nuts that secure the processor-heatsink module to the socket. The nuts can be loosened in any order. Do not attempt to remove the processor-heatsink with the anti-tilt wires locked.

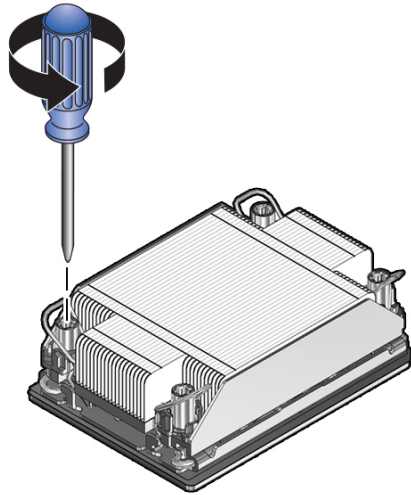

4. Pivot the anti-tilt wire around each of the four captive heatsink load nuts to the unlocked position.

Leave the anti-tilt wires in the unlocked position until installation.

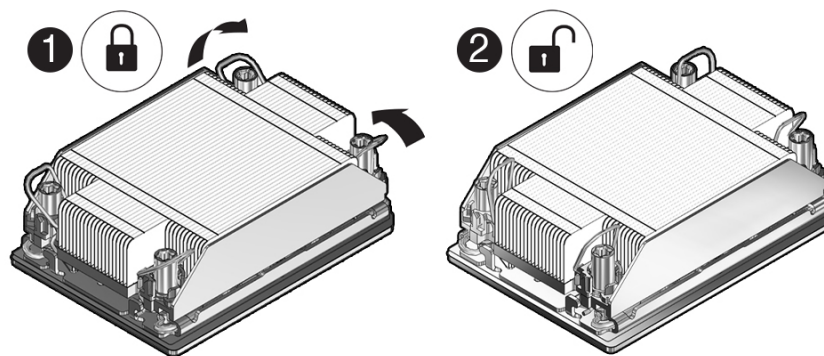

5. Lift the processor-heat sink module straight up from the socket.

 **Note:**

Always hold the processor-heat sink module along the axis of the fins to prevent damage.

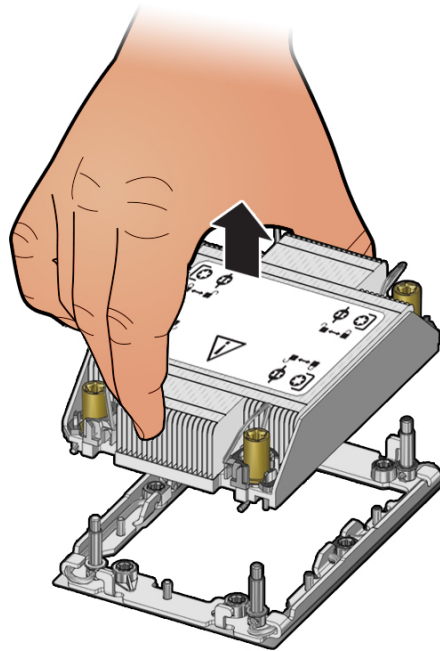

6. Separate the processor from the heatsink.
  - a. Flip over the processor-heatsink module, place it on a flat surface, and locate the thermal interface material (TIM) breaker slot.

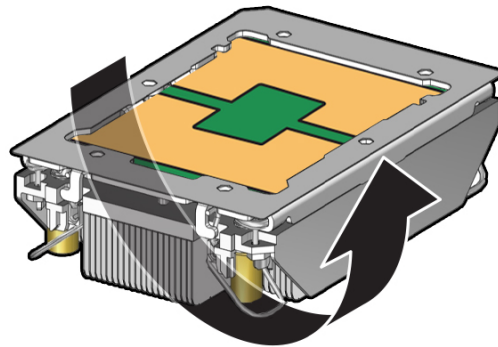

- b. While holding down the heatsink by its edges, insert a flat blade screwdriver into the TIM breaker slot. Using a rocking motion, gently pry the corner of the processor carrier away from the heatsink.

 **Note:**

The blade of the screwdriver should go in to the slot between the heatsink and processor carrier, not the processor and processor carrier.

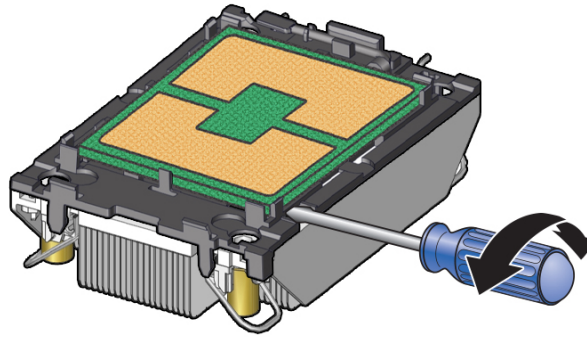

**▲ Caution:**

There is a thin layer of thermal grease between the heatsink and the processor. Do not allow the thermal grease to contaminate the work space or other components.

- c. Remove the processor carrier (with processor still attached) from the heatsink. The carrier has plastic latch tabs that attach it to the heatsink, pry or pinch the tabs as appropriate to detach the carrier from the heatsink.

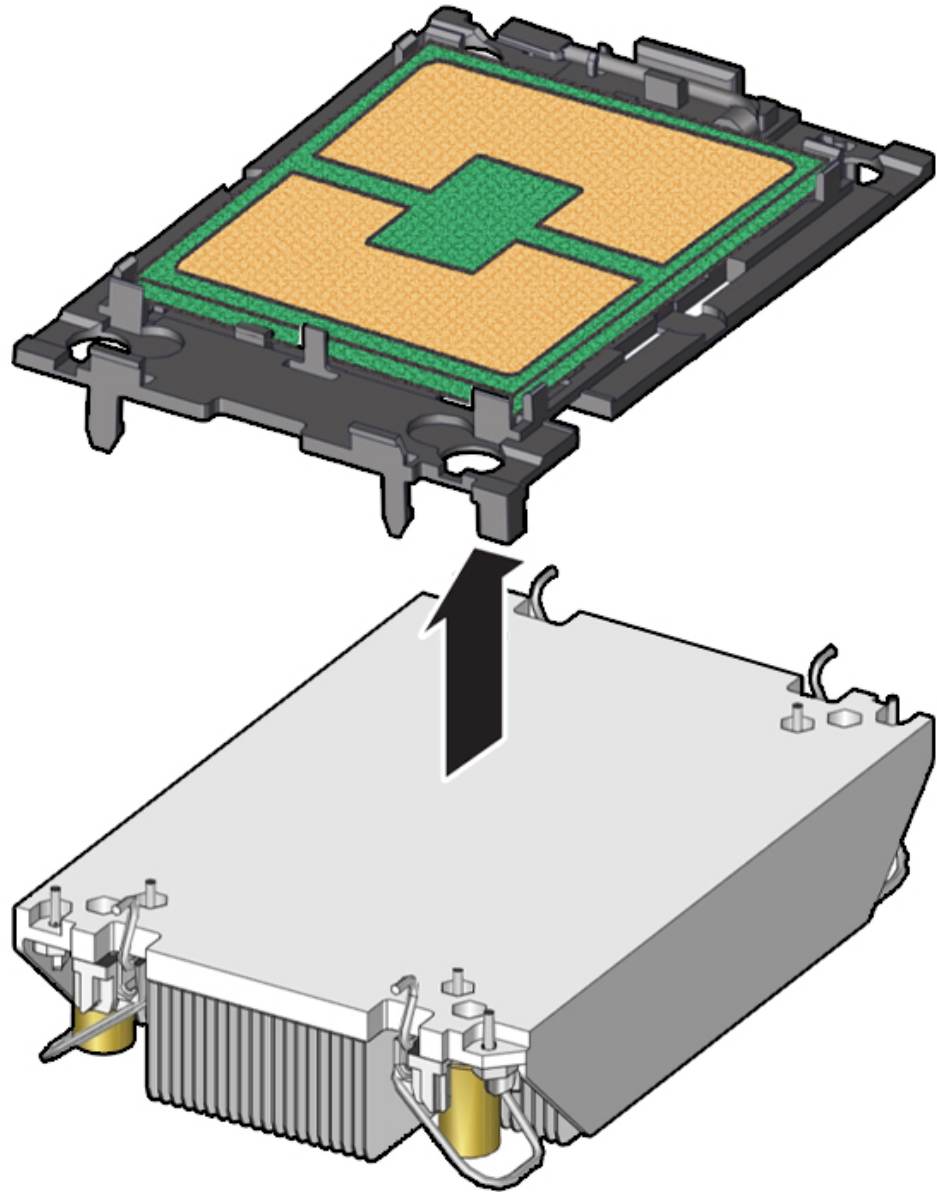

7. If you plan on reusing either the heatsink or processor, clean off the thermal interface material (TIM) using the supplied alcohol wipes. If reusing a processor, do not remove it from the processor carrier.



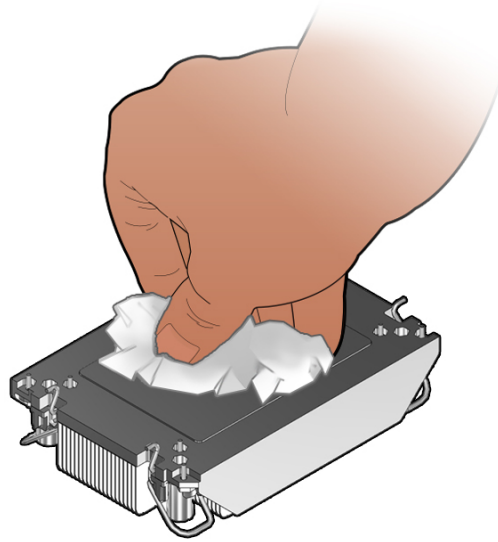

**▲ Caution:**

Failure to clean thermal grease from the heatsink could result in the accidental contamination of the processor socket or other components. Also, be careful not to get the grease on your fingers, as this could result in contamination of components.

**Related Topics**

- [Install a Processor](#)

## Install a Processor

- Use an antistatic wrist strap and a work space with an antistatic mat. See [Electrostatic Discharge Safety](#).
- Use ESD (not latex or vinyl) gloves, if possible, when handling the processor.
- Be careful not to touch the processor socket pins.

**▲ Caution:**

The processor socket pins are very fragile. A light touch can bend the processor socket pins beyond repair.

- Obtain a preset or adjustable torque driver set to 8 in-lbf (inch-pound force) with a T30 Torx bit.

**▲ Caution:**

Using an incorrect torque setting or driver can damage a processor-heatsink module.

- If you are replacing a processor, ensure that the replacement processor is identical to the processor that was removed. For a list of supported processors, see [Product Description](#).
1. Use the syringe supplied with the new or replacement processor [1] to apply 0.3 cc of thermal interface material (TIM) in an "X" pattern to the processor contact area of the heatsink [2].

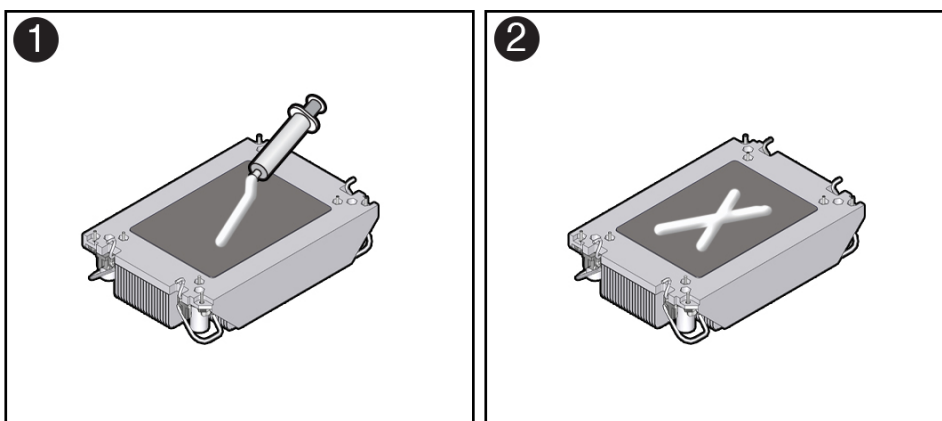
**✎ Note:**

Do not spread the TIM all over the processor contact area of the heatsink; the pressure of the heatsink will do so for you when you install the heatsink.

2. Install the new processor.
  - a. Open the box that contains the new processor but do not remove it from its ESD-safe packaging tray.
  - b. Place the heatsink (TIM adhesive side down) onto the processor carrier until the latch tabs at each corner of the processor carrier attach to the heatsink [1].

**✎ Note:**

There is a die-cut triangle in the processor carrier that points to the pin 1 corner of the processor.

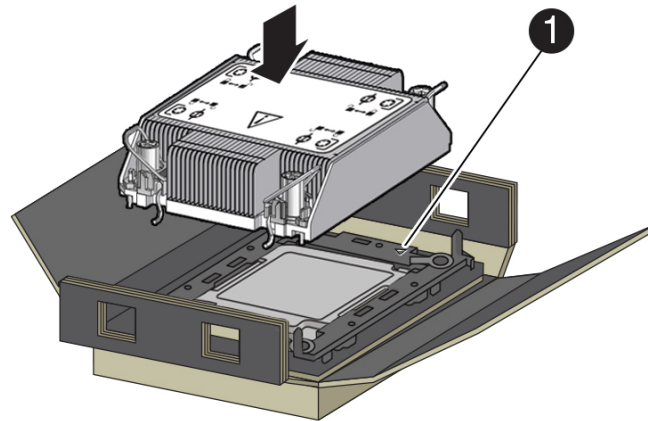

- c. Lift the assembled processor-heatsink module out of the packaging tray.

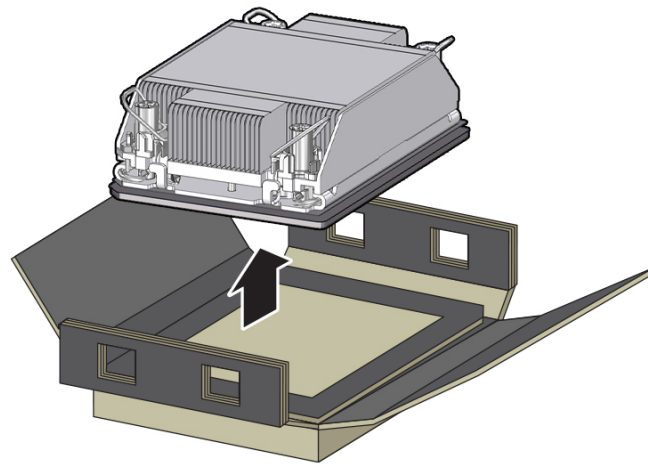

- d. Align the processor-heatsink module with the processor socket bolster plate on the motherboard by matching up the pin 1 corner of the processor (indicated by a gold triangle on the underside of the processor [2]) with the pin 1 corner (indicated by an etched triangle) of the bolster plate [1].

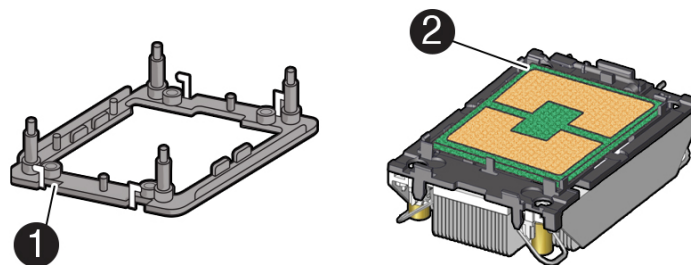

- e. Carefully, place the processor-heatsink module on the socket bolster plate on the motherboard. The bolster plate has four threaded posts, one at each corner to ensure proper alignment.

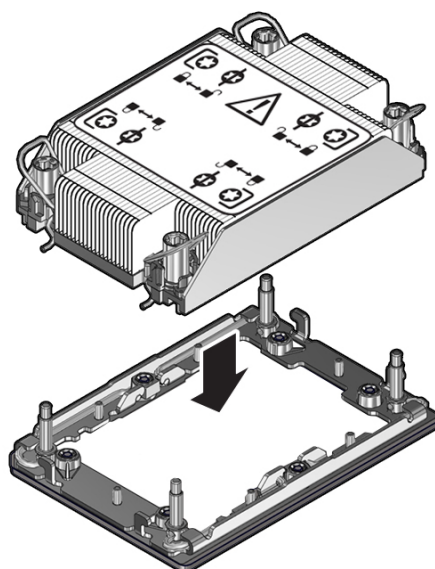

- f. Pivot the anti-tilt wire around each of the four captive heatsink load nuts to the locked position [1] away from the heatsink, engaging the wire with the lock tab on the bolster plate [2].

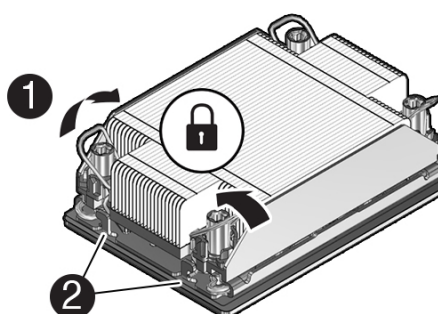

- g. Using a torque driver adjusted to 8 in-lbf with a Torx T30 bit, tighten the four processor heatsink captive load nuts in any order.
3. Return the server to operation.
- a. Install the P0, P1, and power supply air baffles.
  - b. Install the server top cover.  
See [Install the Server Top Cover](#).
  - c. Return the server to the normal rack position.  
See [Return the Server to the Normal Rack Position](#).
  - d. Reconnect the power cords to the power supplies, and power on the server.  
See [Reconnect Data Cables and Power Cords](#) and [Power On the Server](#).
  - e. Verify that the power supply AC OK LED is lit.

4. Use Oracle ILOM to clear the server processor faults.
  - a. To show server faults, log in to Oracle ILOM as root. Using the Oracle ILOM CLI, type the following command to list all known faults on the server:

```
-> show /SP/faultmgmt
```

The server lists all known faults, for example:

```
-> show /SP/faultmgmt
Targets:
  shell
  0 (/SYS/MB/P0)
Properties:
Commands:
  cd
  show
```

Alternatively, log in to the Oracle ILOM service processor from the Oracle ILOM Fault Management Shell and issue the `fmadm faulty` command. For more information about how to use the Oracle ILOM Fault Management Shell and supported commands, see the *Oracle ILOM User's Guide for System Monitoring and Diagnostics* at [Oracle Integrated Lights Out Manager \(ILOM\) 5.0 Documentation](#).

- b. To clear the fault, type the following command:

```
-> set /SYS/MB/P0 clear_fault_action=true
```

For example:

```
-> set /SYS/MB/P0 clear_fault_action=true
Are you sure you want to clear /SYS/MB/P0 (y/n)? y
Set 'clear_fault_action' to 'true'
```

For more information about how to use the Oracle ILOM Fault Management Shell and supported commands, see the *Oracle ILOM User's Guide for System Monitoring and Diagnostics* at [Oracle Integrated Lights Out Manager \(ILOM\) 5.0 Documentation](#).

#### Related Topics

- [Identify and Remove a Processor](#)

# 13

## Servicing the Disk Backplane (FRU)

The following section describes how to service the disk backplane. The disk backplane is a field-replaceable unit (FRU). For more information about FRUs, see [Illustrated Parts Breakdown](#) and [Field-Replaceable Units](#).

**▲ Caution:**

The disk backplane must be removed and replaced only by authorized Oracle Service personnel.

**▲ Caution:**

Ensure that all power is removed from the server before removing or installing the disk backplane. You must disconnect the power cables before performing this procedure.

**▲ Caution:**

These procedures require that you handle components that are sensitive to electrostatic discharge. This sensitivity can cause the component to fail. To avoid damage, ensure that you follow electrostatic discharge safety measures and antistatic practices. See [Electrostatic Discharge Safety](#).

To remove and install the disk backplane, follow these procedures:

- [Remove the Disk Backplane](#)
- [Install the Disk Backplane](#)

**Related Topics**

- [Disconnect Cables From the Server](#)
- [Take Antistatic Measures](#)
- [Extend the Server to the Maintenance Position](#)

## Remove the Disk Backplane

1. Prepare the server for service.
  - a. Power off the server and disconnect the power cords from the power supplies.  
See [Powering Down the Server](#).

- b. Extend the server to the maintenance position.  
See [Extend the Server to the Maintenance Position](#).
        - c. Attach an antistatic wrist strap to your wrist, and then to a metal area on the chassis.  
See [Take Antistatic Measures](#).
        - d. Remove the server top cover.  
See [Remove the Server Top Cover](#).
2. Pull all storage drives out far enough to disengage them from the disk backplane.  
See [Remove a Storage Drive](#).

 **Note:**

It is not necessary to completely remove the storage drives from the server; simply pull them out far enough to disengage them from the disk backplane. If you do remove the storage drives from the server, record their locations so that you can reinstall them in the same locations.

3. Disconnect the following cables from the disk backplane [1]:
  - NVMe cables
  - Disk backplane data cable
  - Temperature sensor cable
  - Disk backplane power cable

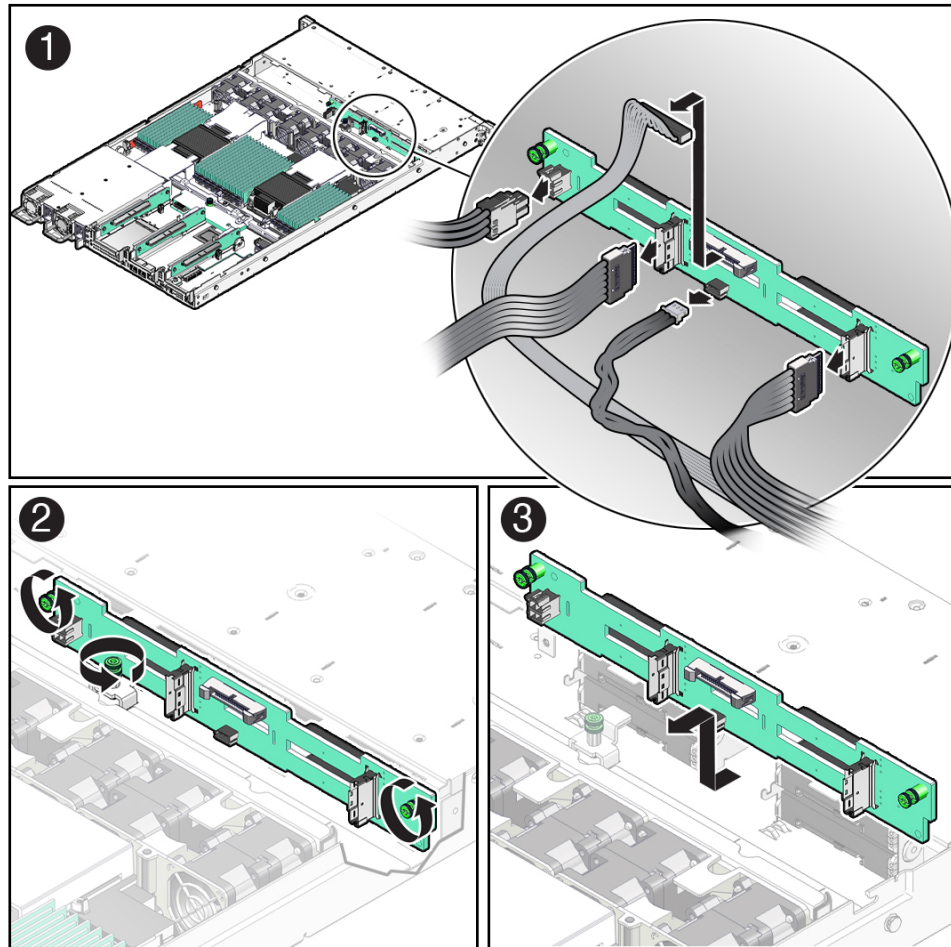

4. Using a Torx T15 screwdriver, loosen the three captive screws that secure the disk backplane to the chassis [2].
5. Lift the backplane up and tilt it toward the rear of the server to free it from the hooks, and lift it out of the server [3].
6. Place the disk backplane on an antistatic mat.

#### Related Topics

- [Install the Disk Backplane](#)

## Install the Disk Backplane

1. Install the disk backplane into the server so that it engages the two metal hooks and also sits behind the metal tabs located on the chassis bottom [1].



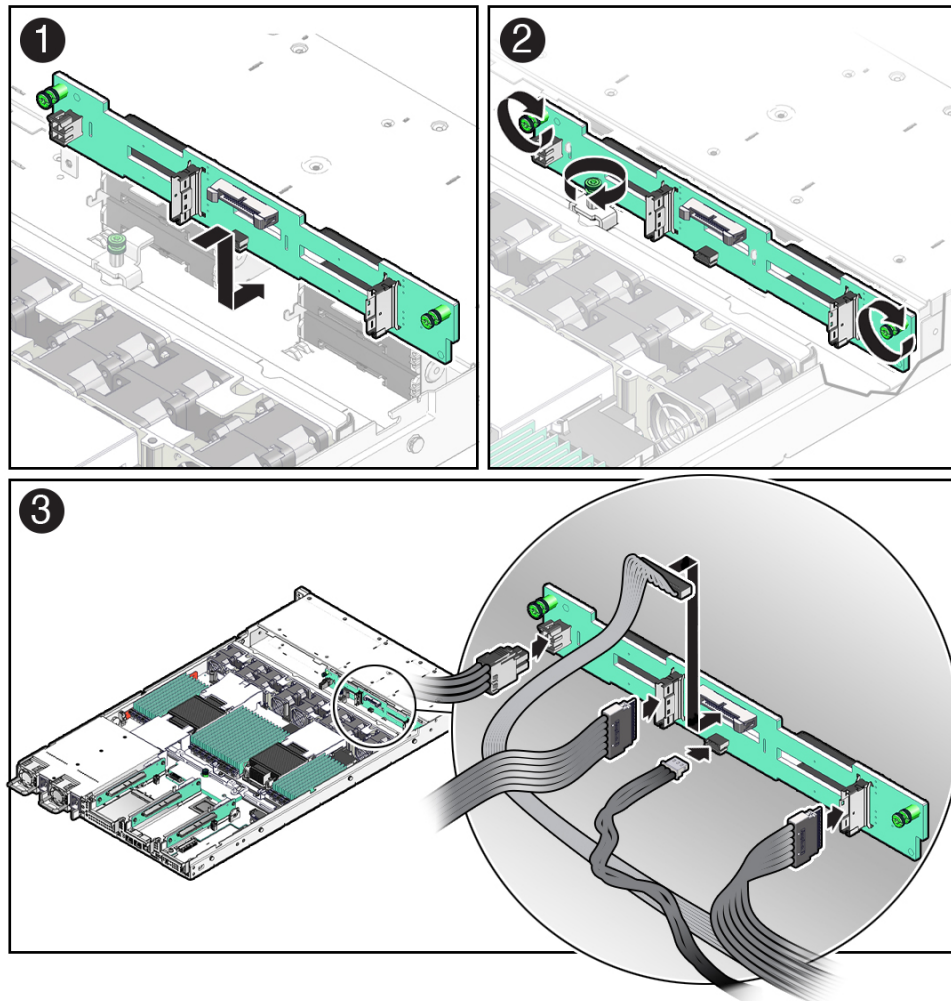

2. Using a Torx T15 screwdriver, tighten the three storage drive backplane captive screws clockwise until the disk backplane is secure [2].
3. Reconnect the following cables to the disk backplane [3]:
  - Disk backplane data cable
  - Temperature sensor cable
  - Disk backplane power cable
  - NVMe cables
4. Reinstall all of the storage drives into the server.  
See [Install a Storage Drive](#).
5. Return the server to operation.
  - a. Install the server top cover.  
See [Install the Server Top Cover](#)
  - b. Return the server to the normal rack position.  
See [Return the Server to the Normal Rack Position](#).
  - c. Reconnect the power cords to the power supplies, and power on the server.

See [Reconnect Data Cables and Power Cords](#) and [Power On the Server](#).

- d. Verify that the System OK status indicator is lit.

 **Note:**

**IMPORTANT:** When the disk backplane is replaced, the key identity properties (KIP) of the backplane is programmed by Oracle ILOM to contain the same KIP as the other quorum member components. If you removed other quorum member components, you might need to manually program the product serial number (PSN) into the new backplane. For more information, see [FRU Key Identity Properties \(KIP\) Automated Update](#).

**Related Topics**

- [Remove the Disk Backplane](#)

# 14

## Servicing the Front LED Indicator Module (FRU)

The following section describes how to service the front indicator module. The front indicator module is a field-replaceable unit (FRU). For more information about FRUs, see [Illustrated Parts Breakdown](#) and [Field-Replaceable Units](#).

### ▲ Caution:

The front indicator module must be removed and replaced only by authorized Oracle Service personnel.

### ▲ Caution:

Ensure that all power is removed from the server before removing or installing the front indicator module. You must disconnect the power cables before performing this procedure.

### ▲ Caution:

These procedures require that you handle components that are sensitive to electrostatic discharge. This sensitivity can cause the component to fail. To avoid damage, ensure that you follow electrostatic discharge safety measures and antistatic practices. See [Electrostatic Discharge Safety](#).

Follow these procedures to remove and install the front indicator module (FIM).

- [Remove the Front LED Indicator Module](#)
- [Install the Front LED Indicator Module](#)

### Related Topics

- [Disconnect Cables From the Server](#)
- [Remove the Server From the Rack](#)
- [Take Antistatic Measures](#)

## Remove the Front LED Indicator Module

1. Prepare the server for service.
  - a. Power off the server and disconnect the power cords from the power supplies.

See [Powering Down the Server](#).

- b. Remove the server from the rack.

See [Remove the Server From the Rack](#).

- c. Attach an antistatic wrist strap to your wrist, and then to a metal area on the chassis.

See [Take Antistatic Measures](#).

2. If attached, remove the left-side mounting bracket from the server chassis.

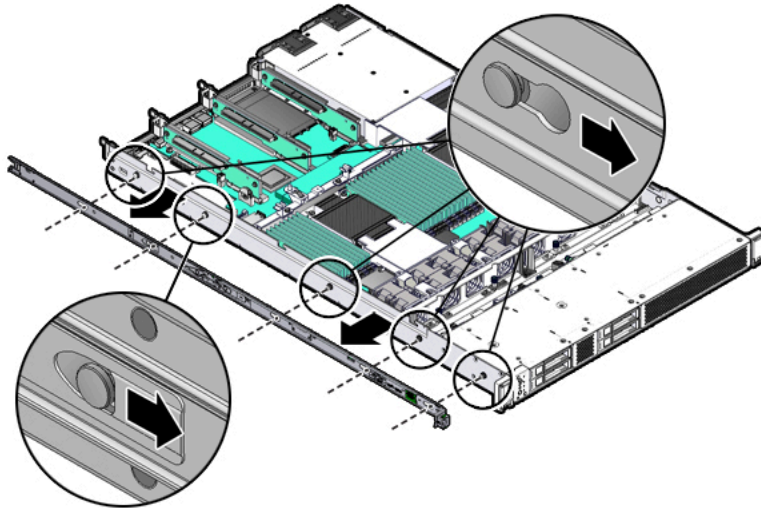

- a. Lift up on the mounting bracket clip to disengage the clip from the chassis locating pin.
  - b. Pull the mounting bracket toward the rear of the chassis until all five chassis locating pins protrude through the five keyhole openings in the mounting bracket.
  - c. Lift the mounting bracket off the locating pins and set it aside.
3. Using a Philips screwdriver, remove the two screws that secure the front indicator module (FIM) assembly to the server chassis [1].

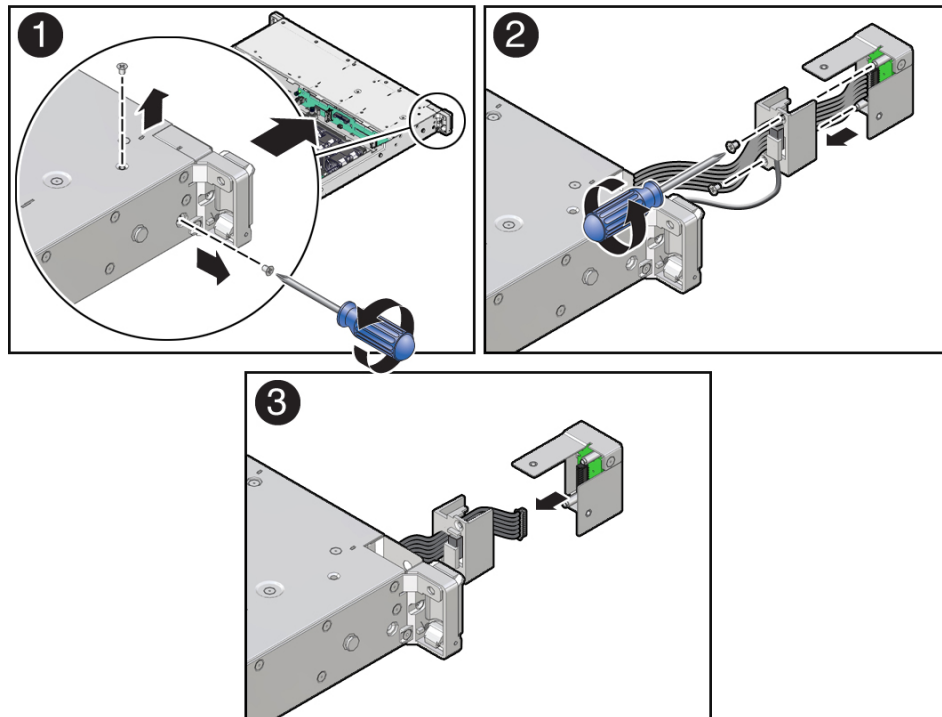

4. Carefully slide the FIM assembly toward the front of the server to remove it from the chassis [2].
5. Using a Phillips screwdriver, remove the two screws that secure the plastic temperature sensor housing to the FIM assembly, and then detach the housing from the FIM assembly [2].

 **Note:**

You do not need to remove the temperature sensor from the housing.

6. Disconnect the FIM cable from the FIM assembly and set the FIM assembly aside [3].
7. Continue to Install the Front LED Indicator Module.

**Related Topics**

- [Install the Front LED Indicator Module](#)

## Install the Front LED Indicator Module

1. Attach an antistatic wrist strap to your wrist, and then to a metal area on the chassis. See [Take Antistatic Measures](#).
2. Unpack the replacement FIM and place it on an antistatic mat.
3. If not installed, install the FIM cable through the plastic temperature sensor housing [1].

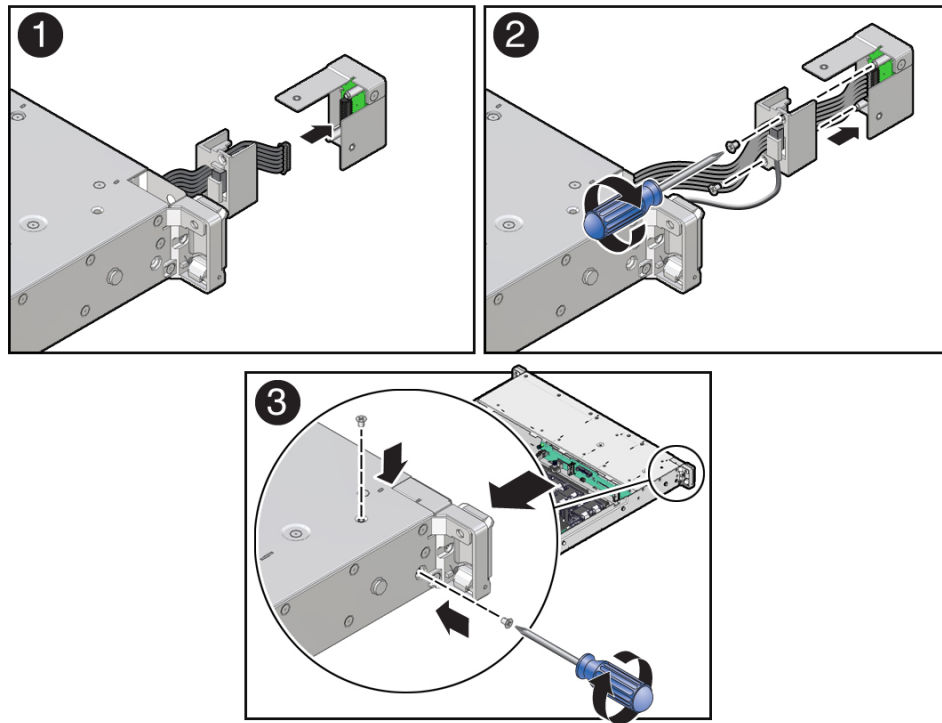

4. Connect the FIM cable to the replacement FIM assembly [1, 2].
5. Using a Phillips screwdriver, tighten the two screws to secure the temperature sensor housing to the FIM assembly [2].
6. Carefully insert the FIM assembly into the front panel of the server chassis [3].
7. Install and tighten the two Phillips screws to secure the FIM assembly to the server chassis [3].
8. (Optional) If required, reattach the left-side mounting bracket to the server chassis.

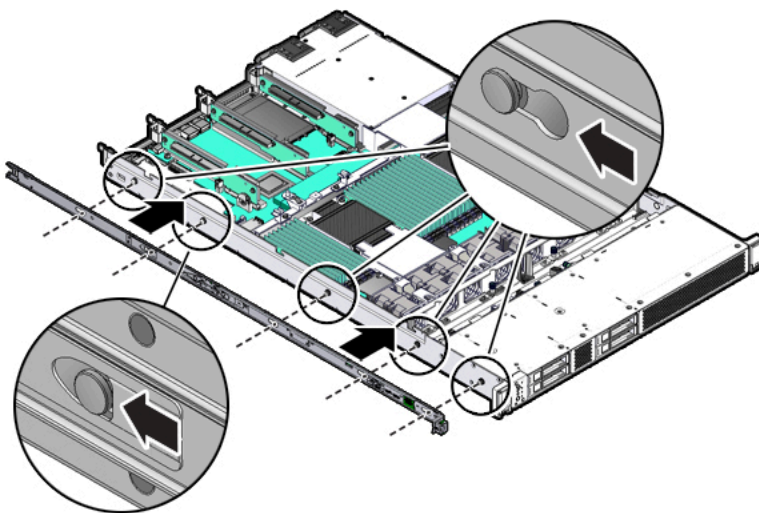

- a. Position the mounting bracket against the chassis so that the five keyhole openings on the mounting bracket are aligned with the five locating pins on the side of the chassis.
  - b. When the heads of the five chassis locating pins protrude through the five keyhole openings in the mounting bracket, pull the mounting bracket toward the front of the chassis until the mounting bracket clip locks into place with an audible click.
  - c. Verify that the locating pin is engaged with the mounting bracket clip.
9. Return the server to operation.
  - a. Reinstall the server into the rack.  
See [Reinstall the Server Into the Rack](#).
  - b. Reconnect the power cords to the power supplies, and power on the server.  
See [Reconnect Data Cables and Power Cords](#) and [Power On the Server](#).
  - c. Verify that the System OK status indicator is lit.

#### Related Topics

- [Remove the Front LED Indicator Module](#)

# Servicing the Temperature Sensor (FRU)

The following section describes how to service the temperature sensor. The temperature sensor is a field-replaceable unit (FRU). For more information about FRUs, see [Illustrated Parts Breakdown](#) and [Field-Replaceable Units](#).

**▲ Caution:**

The temperature sensor must be removed and replaced only by authorized Oracle Service personnel.

**▲ Caution:**

Ensure that all power is removed from the server before removing or installing the temperature sensor. You must disconnect the power cables before performing this procedure.

**▲ Caution:**

These procedures require that you handle components that are sensitive to electrostatic discharge. This sensitivity can cause the component to fail. To avoid damage, ensure that you follow electrostatic discharge safety measures and antistatic practices. See [Electrostatic Discharge Safety](#).

This section covers the following procedures:

- [Remove the Temperature Sensor](#)
- [Install the Temperature Sensor](#)

**Related Topics**

- [Disconnect Cables From the Server](#)
- [Remove the Server From the Rack](#)
- [Take Antistatic Measures](#)

## Remove the Temperature Sensor

1. Prepare the server for service.
  - a. Power off the server and disconnect the power cords from the power supplies.  
See [Powering Down the Server](#).





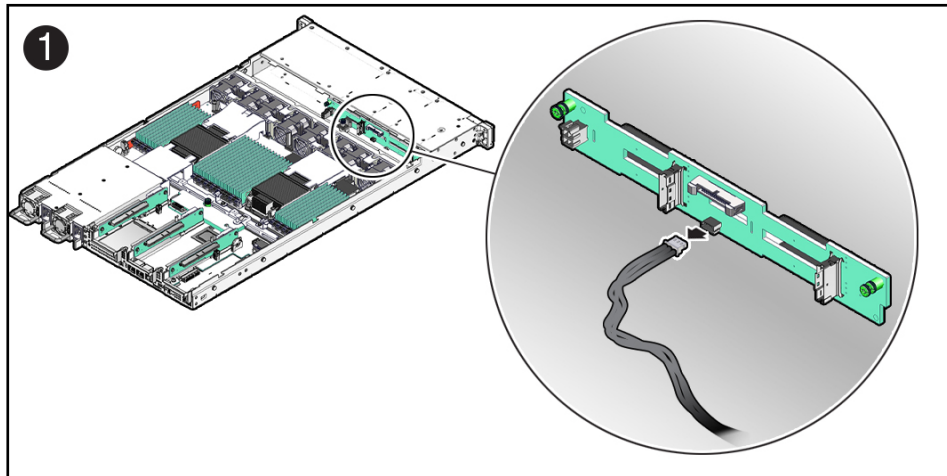

4. Using a Phillips screwdriver, remove the two screws that secure the front indicator module (FIM) assembly to the server chassis [1].

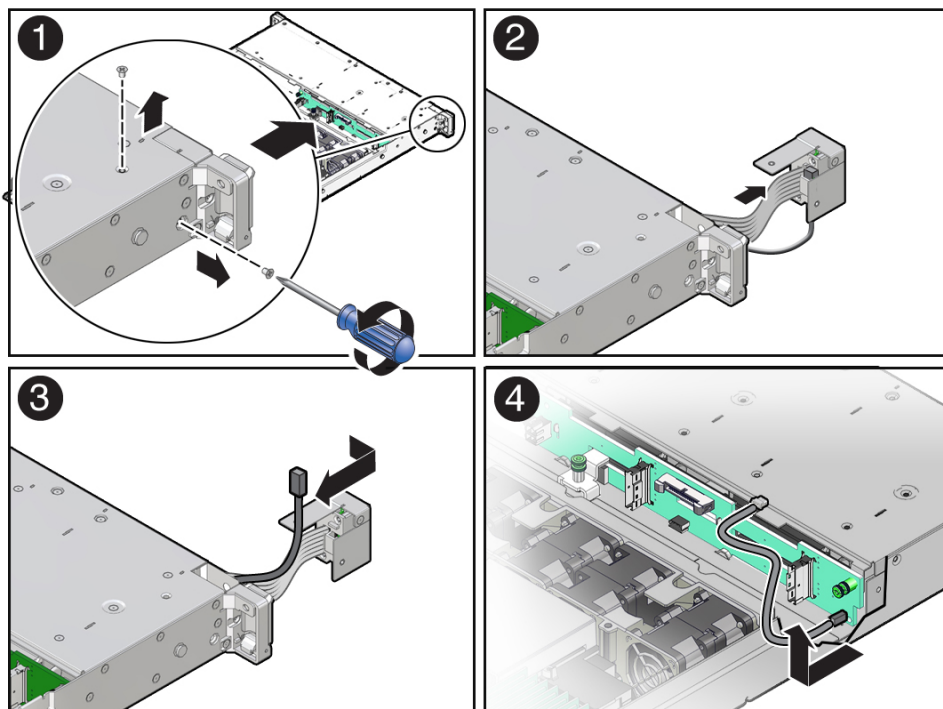

5. Carefully slide the FIM assembly toward the front of the server to remove it from the chassis [2].
6. Remove the temperature sensor from the plastic housing by pulling the sensor from its seated location, and remove the sensor cable by pulling it through the slit in the housing [2, 3].
7. Remove the temperature sensor and cable by carefully pulling the sensor cable rearward and through the left-front chassis sidewall, and lift the temperature sensor from the chassis [4].

### Related Topics

- [Install the Temperature Sensor](#)

## Install the Temperature Sensor

1. Install the temperature sensor by carefully inserting the sensor-end of the cable through the rear opening directly under the left side of the disk backplane, and push/pull the sensor cable through the left-front chassis sidewall [1].

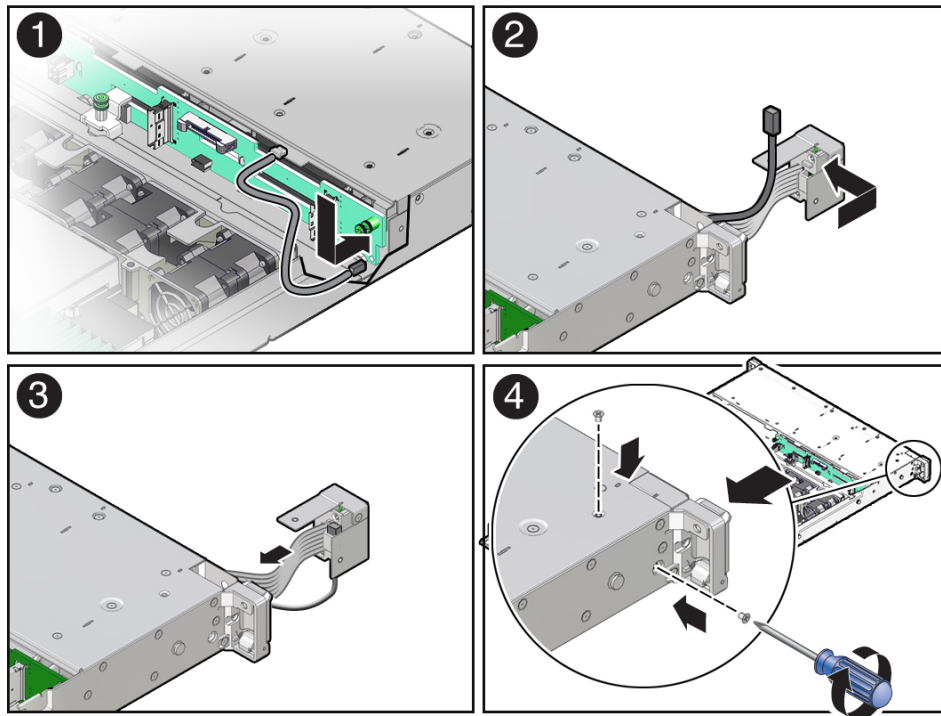

2. Install the temperature sensor into the plastic housing by inserting the cable through the slit in the housing, and ensure that the temperature sensor is properly seated into the housing [2, 3].
3. Carefully insert the FIM assembly into the front panel of the server chassis [3].
4. Install and tighten the two Phillips screws to secure the FIM assembly to the server chassis [4].
5. Reconnect the temperature sensor cable to the disk backplane.

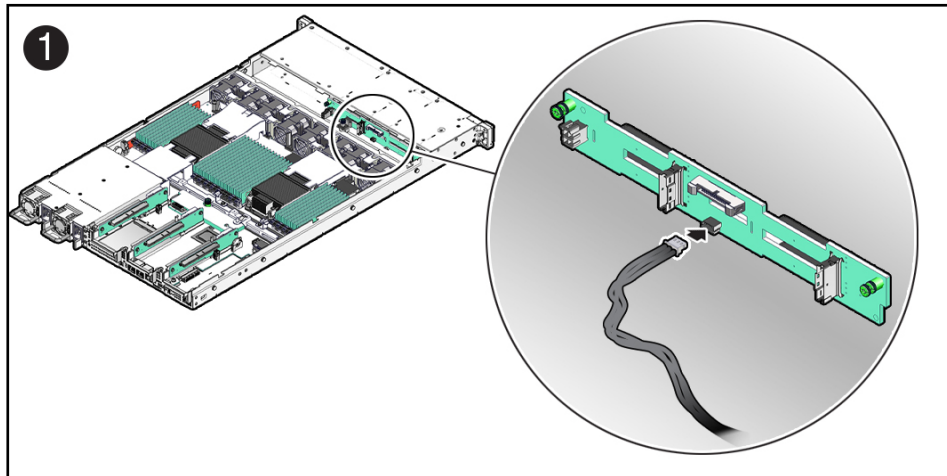

6. If required, reattach the left-side mounting bracket to the server chassis.

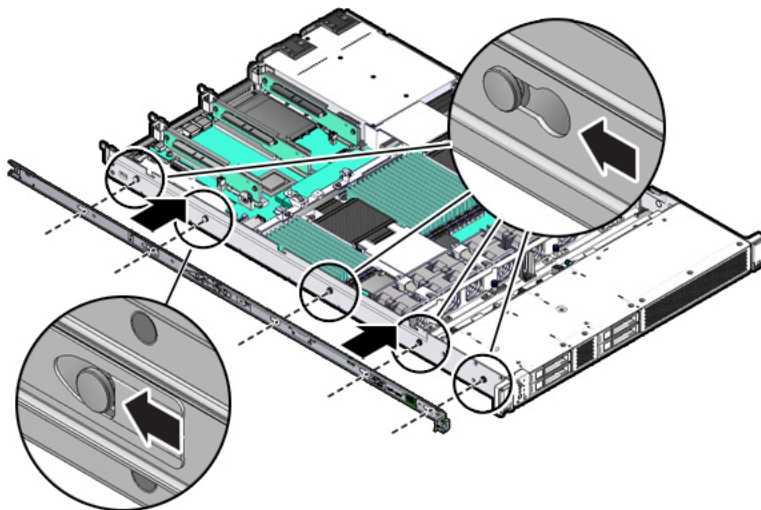

- a. Position the mounting bracket against the chassis so that the five keyhole openings on the mounting bracket are aligned with the five locating pins on the side of the chassis.
  - b. When the heads of the five chassis locating pins protrude through the five keyhole openings in the mounting bracket, pull the mounting bracket toward the front of the chassis until the mounting bracket clip locks into place with an audible click.
  - c. Verify that the locating pin is engaged with the mounting bracket clip.
7. Return the server to operation.
  - a. Install the server top cover.  
See [Install the Server Top Cover](#).
  - b. Reinstall the server into the rack.  
See [Reinstall the Server Into the Rack](#).

- c. Reconnect the power cords to the power supplies, and power on the server.  
See [Reconnect Data Cables and Power Cords](#) and [Power On the Server](#).
- d. Verify that the power supply AC OK LED is lit.

**Related Topics**

- [Remove the Temperature Sensor](#)

# 16

## Servicing the NVMe Cables

The following section describes how to service the NVMe cables. The NVMe cables are field-replaceable units (FRUs). For more information about FRUs, see [Illustrated Parts Breakdown](#) and [Field-Replaceable Units](#).

### ▲ Caution:

The NVMe cables must be removed and replaced only by authorized Oracle Service personnel.

### ▲ Caution:

Ensure that all power is removed from the server before removing or installing the NVMe cables. You must disconnect the power cables before performing this procedure.

### ▲ Caution:

These procedures require that you handle components that are sensitive to electrostatic discharge. This sensitivity can cause the component to fail. To avoid damage, ensure that you follow electrostatic discharge safety measures and antistatic practices. See [Electrostatic Discharge Safety](#).

This section covers the following procedures:

- [Remove NVMe Cables](#)
- [Install NVMe Cables](#)

#### Related Topics

- [Extend the Server to the Maintenance Position](#)
- [Take Antistatic Measures](#)
- [Remove the Server Top Cover](#)

## Remove NVMe Cables

1. Prepare the server for service.
  - a. Power off the server and disconnect the power cords from the power supplies.  
See [Powering Down the Server](#).

- b. Extend the server to the maintenance position.  
See [Extend the Server to the Maintenance Position](#).
  - c. Attach an antistatic wrist strap to your wrist, and then to a metal area on the chassis.  
See [Take Antistatic Measures](#).
  - d. Remove the server top cover.  
See [Remove the Server Top Cover](#).
  - e. Remove the P0 upper air baffle [1].  
Lift the air baffle up and out of the chassis and set it aside.
2. Disconnect the NVMe A and B cables from the disk backplane by pressing the latch on the cable connector and then pulling out the connector [2].

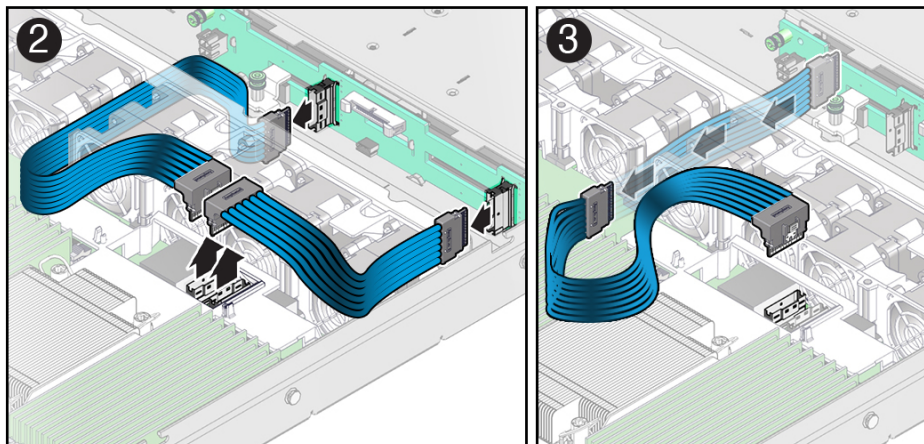
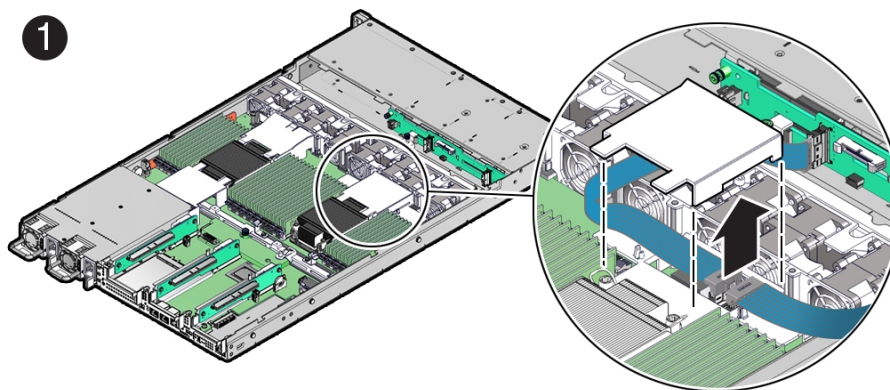

3. Disconnect the NVMe A and B cables from the motherboard NVMe connectors [2].

 **Note:**

(Optional) To ease the disconnecting of cables, you might need to remove the FM0 fan module. See [Remove a Fan Module](#).

- Carefully lift the NVMe A cable from the left-side trough and gently pull the NVMe B cable through the center cable trough and remove them from the server [2, 3].

#### Related Topics

- [Install NVMe Cables](#)

## Install NVMe Cables

- Carefully install the NVMe A cable into the left-side trough and pull the NVMe B cable through the center cable trough [1, 2].

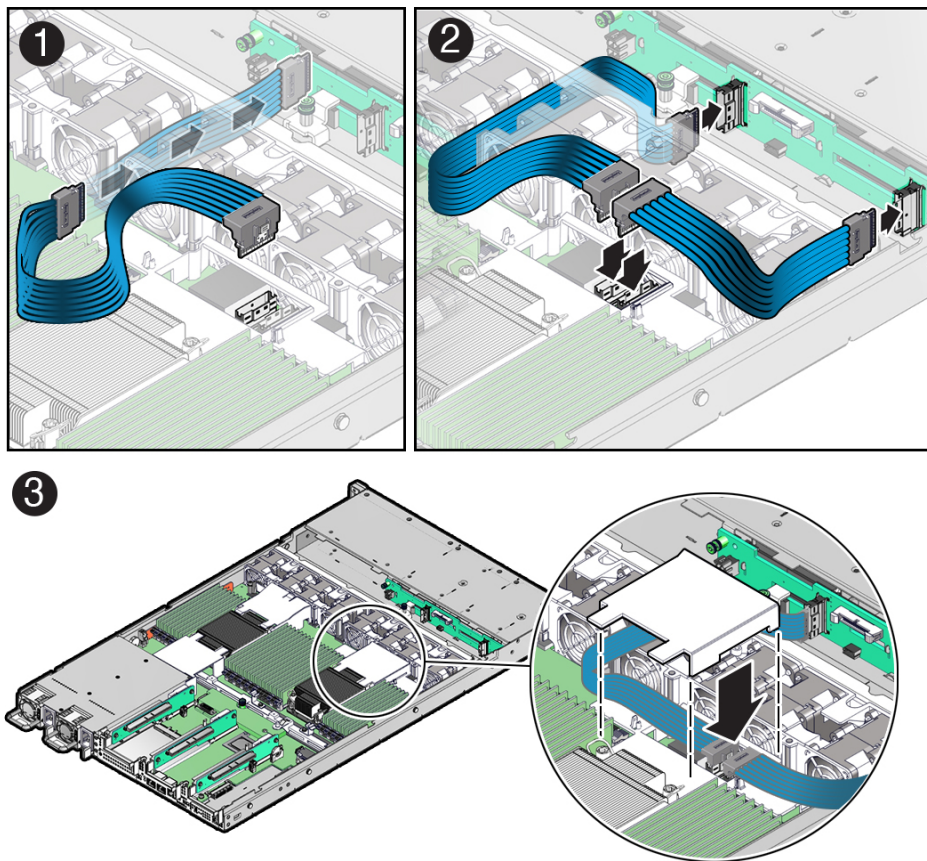

- Connect the NVMe A and B cables to the motherboard NVMe connectors [2].

#### Note:

An NVMe A cable (part number 7363957) and NVMe B cable (part number 8201504) are required to connect the motherboard NVMe connectors to the disk backplane.



 **Note:**

Each NVMe cable contains a matching label that corresponds to connectors on the motherboard and the disk backplane. For example, the NVMe cable labeled A, plugs into motherboard NVMe A connector and the disk backplane NVMe A connector.

Use the following table to ensure proper NVMe cable connections.

Motherboard NVMe Connector	Disk Backplane Connector	Storage Drives
A	A	0, 1
B	B	2, 3

3. Connect the NVMe cables to the disk backplane [2].  
To ensure proper connections, see the NVMe cable connections table in [Step 2](#).
4. Return the server to operation.
  - a. Install the P0 upper air baffle [3].  
Position the P0 upper air baffle into the chassis and place it on top of the adjoining P0 lower baffle.
  - b. Install the server top cover.  
See [Install the Server Top Cover](#).
  - c. Return the server to the normal rack position.  
See [Return the Server to the Normal Rack Position](#).
  - d. Reconnect the power cords to the power supplies, and power on the server.  
See [Reconnect Data Cables and Power Cords](#) and [Power On the Server](#).
  - e. Verify that the System OK status indicator is lit.

**Related Topics**

- [Remove NVMe Cables](#)

# 17

## Servicing Other Cables (FRU)

The following section describes how to service the front indicator module (FIM), temperature sensor, and disk backplane data and power cables. These cables are field-replaceable units (FRUs). For more information about FRUs, see [Illustrated Parts Breakdown](#) and [Field-Replaceable Units](#).

### ▲ Caution:

The FIM, temperature sensor, and disk backplane data and power cables must be removed and replaced only by authorized Oracle Service personnel.

### ▲ Caution:

Ensure that all power is removed from the server before removing or installing these cables. You must disconnect the power cables before performing this procedure.

### ▲ Caution:

These procedures require that you handle components that are sensitive to electrostatic discharge. This sensitivity can cause the component to fail. To avoid damage, ensure that you follow electrostatic discharge safety measures and antistatic practices. See [Electrostatic Discharge Safety](#).

This section covers the following procedures:

- [Remove the FIM, Temperature Sensor, and Disk Backplane Data and Power Cables](#)
- [Install the FIM, Temperature Sensor, and Disk Backplane Data and Power Cables](#)

### Related Topics

- [Extend the Server to the Maintenance Position](#)
- [Take Antistatic Measures](#)
- [Remove the Server Top Cover](#)

## Remove the FIM, Temperature Sensor, and Disk Backplane Data and Power Cables

1. Prepare the server for service.
  - a. Power off the server and disconnect the power cords from the power supplies.

See [Powering Down the Server](#).

- b.** Extend the server to the maintenance position.

See [Extend the Server to the Maintenance Position](#).

- c.** Attach an antistatic wrist strap to your wrist, and then to a metal area on the chassis.

See [Take Antistatic Measures](#).

- d.** Remove the server top cover.

See [Remove the Server Top Cover](#).

- 2.** Remove the disk backplane power cable.

- a.** Disconnect the disk backplane power cable from the motherboard by pressing the release latch on the side of the cable connector and pulling out the connector [1].

- b.** Disconnect the disk backplane power cable from the disk backplane by pressing the release latch on the side of the cable connector and pulling out the connector [2].

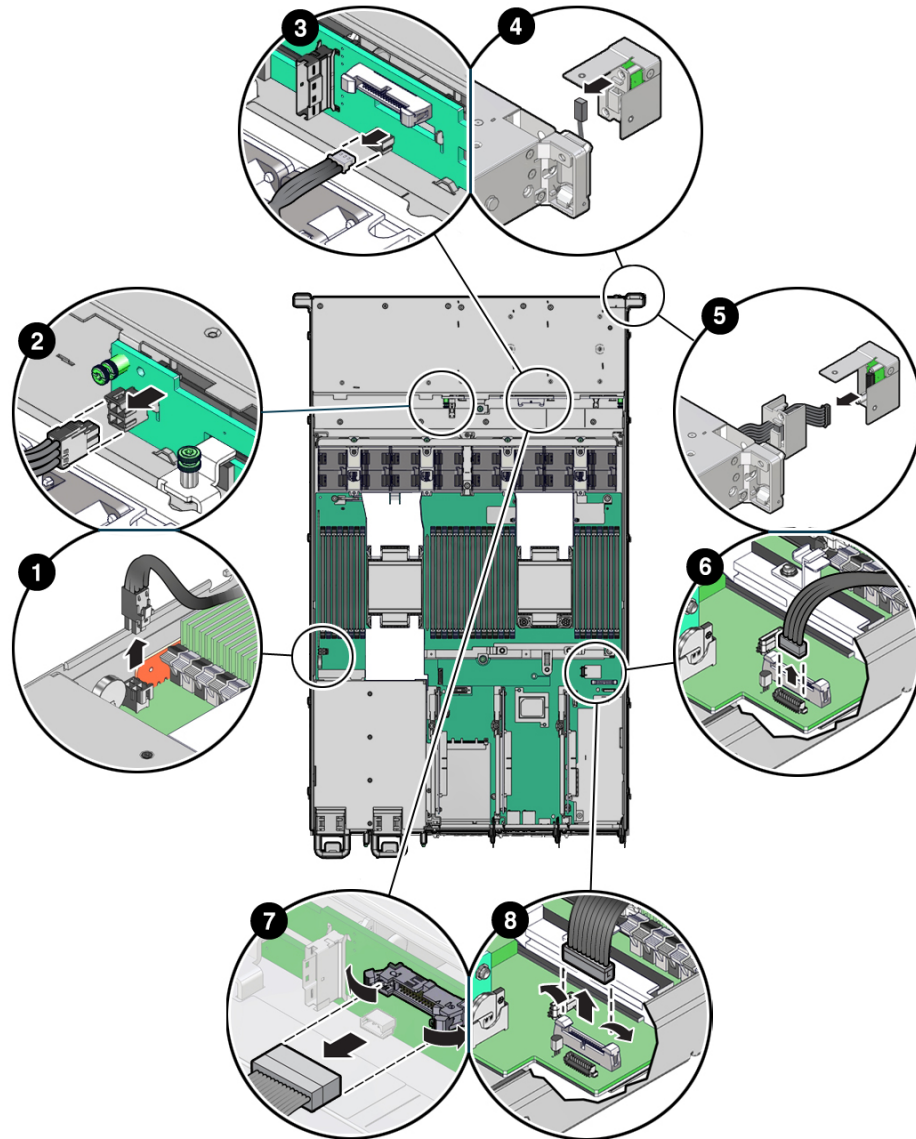

3. Remove the temperature sensor cable.
  - a. Remove the FIM from the server.  
See [Remove the Temperature Sensor](#).
  - b. Disconnect the temperature sensor cable from the disk backplane by pulling the cable from the connector [3].

 **Note:**

To ease extraction, you might need to disconnect the disk backplane data cable from the disk backplane before disconnecting this cable.

- c. Remove the temperature sensor and cable from the FIM housing, then pull the cable and sensor through the left-front chassis sidewall [4].
4. Remove the FIM cable.

- a. Remove the FIM from the server.  
See [Remove the Front LED Indicator Module](#)
- b. Disconnect the FIM cable from the FIM by pulling the cable from the connector [5].
- c. Eject the FIM cable from the motherboard by pulling the cable from the connector [6].

 **Note:**

To ease extraction, you might need to disconnect the disk backplane data cable from the motherboard before disconnecting this cable.

5. Remove the disk backplane data cable.
  - a. Eject the disk backplane data cable from the disk backplane by opening both side latches on the connector [7].
  - b. Eject the disk backplane data cable from the motherboard by opening both side latches on the connector [8].

**Related Topics**

- [Install the FIM, Temperature Sensor, and Disk Backplane Data and Power Cables](#)

## Install the FIM, Temperature Sensor, and Disk Backplane Data and Power Cables

1. Install the disk backplane data cable.
  - a. Connect the disk backplane data cable to the motherboard by opening both side latches and plugging the data cable connector into the motherboard connector [8].

The motherboard connector side latches will close, locking the disk backplane data cable connector in place.
  - b. Connect the disk backplane data cable to the disk backplane by opening both side latches and plugging the data cable connector into the disk backplane connector [7].

The disk backplane connector side latches will close, locking the disk backplane data cable connector in place.
2. Install the FIM cable.
  - a. Install the FIM cable into the motherboard by plugging the FIM connector into the motherboard connector [6].
  - b. Connect the FIM cable to the FIM by plugging the cable connector into the FIM [5].
  - c. Install the FIM into the server.  
See [Install the Front LED Indicator Module](#).
3. Install the temperature sensor cable.
  - a. Route the temperature sensor cable through the left-front chassis sidewall and install the sensor into the FIM housing [4].



# 18

## Servicing the OCP Network Interface Card (FRU)

The following section describes how to service and install the Open Compute Project (OCP) version 3.0 (V3) Network Interface Card (NIC). The OCP V3 NIC is a field-replaceable unit (FRU). For more information about FRUs, see [Illustrated Parts Breakdown](#) and [Field-Replaceable Units](#).

### ▲ Caution:

The OCP NIC must be removed and replaced only by authorized Oracle Service personnel.

### ▲ Caution:

Ensure that all power is removed from the server before removing or installing the OCP NIC. You must disconnect all power cables from the system before performing these procedures.

### ▲ Caution:

These procedures require that you handle components that are sensitive to electrostatic discharge. This sensitivity can cause the component to fail. To avoid damage, ensure that you follow electrostatic discharge safety measures and antistatic practices. See [Electrostatic Discharge Safety](#).

This section covers the following procedures:

- [Remove the OCP Network Interface Card](#)
- [Install the OCP Network Interface Card](#)

### Related Topics

- [Disconnect Cables From the Server](#)
- [Take Antistatic Measures](#)
- [Extend the Server to the Maintenance Position](#)

## Remove the OCP Network Interface Card

1. Prepare the server for service.

- a. Power off the server and disconnect the power cords from the power supplies.  
See [Powering Down the Server](#).
  - b. Disconnect data cables from the OCP NIC QSFP ports (PORT 1 and PORT 2).
  - c. Extend the server to the maintenance position.  
See [Extend the Server to the Maintenance Position](#).
  - d. Attach an antistatic wrist strap to your wrist, and then to a metal area on the chassis.  
See [Take Antistatic Measures](#).
  - e. Remove the server top cover.  
See [Remove the Server Top Cover](#).
2. Remove the following components:
- Air baffles

 **Note:**

You need to remove only the P1 rear air baffle from the server. All other air baffles can remain in the server.

- Fan modules  
See [Remove a Fan Module](#).
- PCIe risers with attached PCIe cards  
See [Servicing PCIe Risers \(CRU\)](#).

 **Note:**

You do not need to remove attached PCIe cards from risers, as it is necessary to lift only the PCIe risers from the server to disengage the attached PCIe card rear brackets from the server chassis.

- Power supplies  
See [Remove a Power Supply](#).

 **Note:**

It is not necessary to completely remove the power supplies from the server; simply pull them out far enough to disengage them from the motherboard connectors.

3. Using a Torx T25 screwdriver, loosen the green captive screw that secures the motherboard to the server chassis [1].



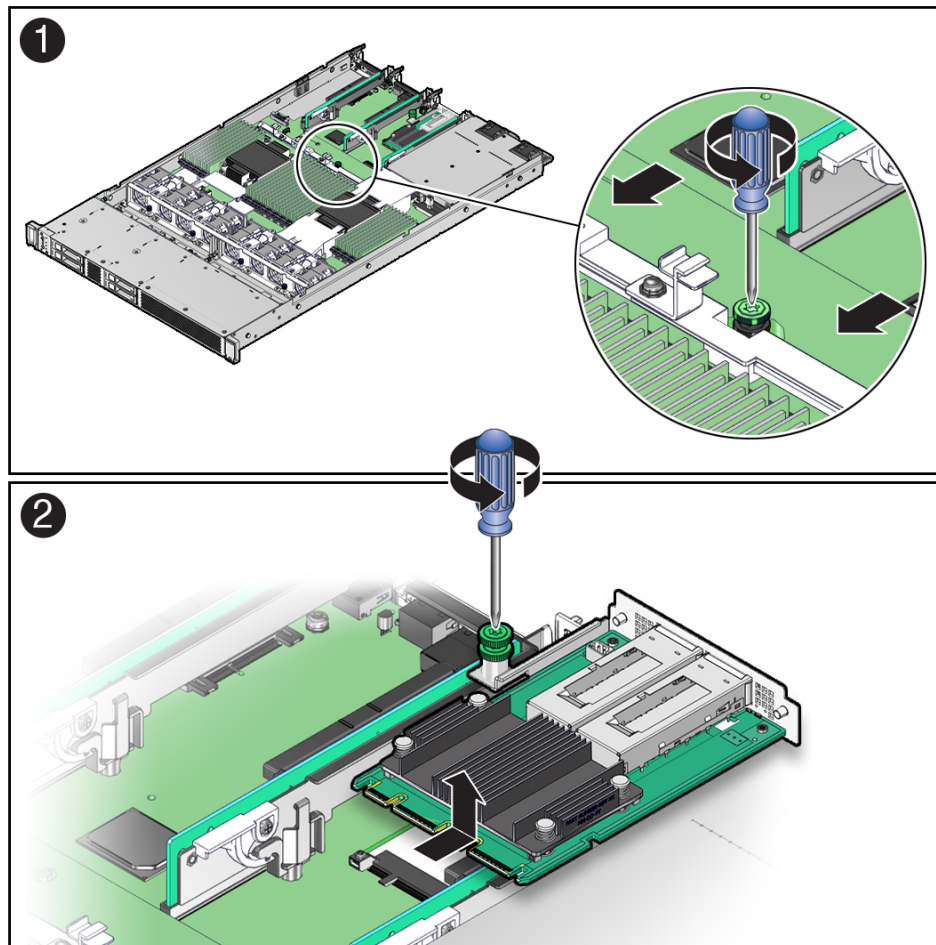

4. Grasp the motherboard handle and the motherboard front finger loop, and slide the motherboard toward the front of the server until the OCP NIC QSFP connectors have cleared the rear panel cutouts [1].
5. Using a Torx T25 screwdriver, loosen the green captive (retention) screw that secures the OCP NIC to the motherboard [2].
6. Grasp the OCP NIC and pull it toward the rear of the chassis to disengage the OCP NIC connector from the motherboard connector slot [2].
7. Lift the OCP NIC from the motherboard and out of the server chassis [2].

#### Related Topics

- [Field-Replaceable Units](#)
- [Install the OCP Network Interface Card](#)

## Install the OCP Network Interface Card

1. Unpack the replacement OCP NIC.
2. Insert the OCP NIC into the server chassis [1].

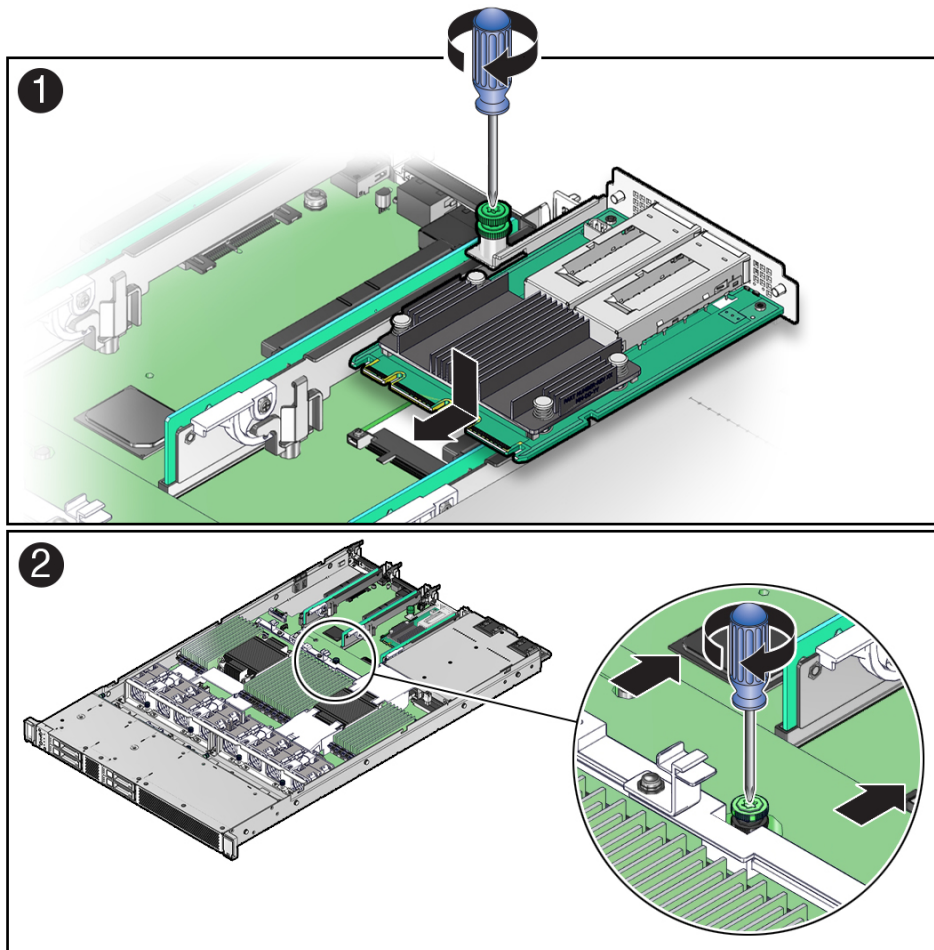

3. Align the OCP NIC connector with the motherboard connector slot, and gently push the OCP NIC connector into the motherboard connector slot [1].
4. Using a Torx T25 screwdriver, tighten the green captive (retention) screw to secure the OCP NIC to the motherboard [1].
5. Grasp the motherboard handle and the motherboard front finger loop, and slide the motherboard toward the rear of the server until the OCP NIC QSFP connectors fit correctly into the rear panel cutouts [2].

 **Note:**

Ensure that all indicators, controls, and connectors on the rear of the motherboard fit correctly into the rear panel cutouts.

6. Using a Torx T25 screwdriver, tighten the green captive screw to secure the motherboard to the server chassis [2].
7. Reinstall the following reusable components:
  - Power supplies  
See [Install a Power Supply](#).
  - PCIe risers with attached PCIe cards

See [Servicing PCIe Risers \(CRU\)](#).

- Fan modules

See [Install a Fan Module](#).

- Air baffles

8. Return the server to operation.

- a. Install the server top cover.

See [Install the Server Top Cover](#).

- b. Return the server to the normal rack position.

See [Return the Server to the Normal Rack Position](#).

- c. Reconnect the data cables to the OCP NIC QSFP ports (PORT 1 and PORT 2).

- d. Reconnect the power cords to the power supplies, and power on the server.

See [Reconnect Data Cables and Power Cords](#) and [Power On the Server](#).

- e. Verify that the System OK status indicator is lit.

#### **Related Topics**

- [Field-Replaceable Units](#)
- [Remove the OCP Network Interface Card](#)

# 19

## Servicing the Motherboard Assembly (FRU)

The following section describes how to service the motherboard assembly. The motherboard assembly is a field-replaceable unit (FRU). For more information about FRUs, see [Illustrated Parts Breakdown](#) and [Field-Replaceable Units](#).

### ▲ Caution:

The motherboard assembly must be removed and replaced only by authorized Oracle Service personnel.

### ▲ Caution:

Ensure that all power is removed from the server before removing or installing the motherboard. You must disconnect the power cables before performing these procedures.

### ▲ Caution:

These procedures require that you handle components that are sensitive to electrostatic discharge. This sensitivity can cause the component to fail. To avoid damage, ensure that you follow electrostatic discharge safety measures and antistatic practices. See [Electrostatic Discharge Safety](#).

- [Remove the Motherboard](#)
- [Install the Motherboard](#)

#### Related Topics

- [Remove the Server From the Rack](#)
- [Take Antistatic Measures](#)
- [Remove the Server Top Cover](#)

## Remove the Motherboard

### ▲ Caution:

Use the Oracle ILOM backup utility prior to removing the motherboard. This utility backs up the Oracle ILOM configuration of the service processor. For more information, see the [Oracle Integrated Lights Out Manager \(ILOM\) 5.0 Documentation](#).

1. Prepare the server for service.
  - a. Power off the server and disconnect the power cords from the power supplies.  
See [Powering Down the Server](#).
  - b. Extend the server to the maintenance position.  
See [Extend the Server to the Maintenance Position](#).
  - c. Attach an antistatic wrist strap to your wrist, and then to a metal area on the chassis.  
See [Take Antistatic Measures](#).
  - d. Remove the server top cover.  
See [Remove the Server Top Cover](#).
2. Remove the following reusable components:

### ▲ Caution:

During the motherboard removal procedure, it is important to label power supplies with the slot numbers from which they were removed (PS0, PS1). This is required because the power supplies must be reinstalled into the slots from which they were removed; otherwise, the server key identity properties (KIP) data might be lost. When a server requires service, the KIP is used by Oracle to verify that the warranty on the server has not expired. For more information on KIP, see [FRU Key Identity Properties \(KIP\) Automated Update](#).

- Air baffles
  - Fan modules  
See [Remove a Fan Module](#).
  - Power supplies  
See [Remove a Power Supply](#).
  - PCIe risers and attached PCIe cards  
See [Servicing PCIe Risers \(CRU\)](#) and [Servicing PCIe Cards \(CRU\)](#).
3. Remove cables from the motherboard.

- a. Disconnect the disk backplane power cable from the motherboard by pressing in on the connector latch and then pulling out the cable connector [1].

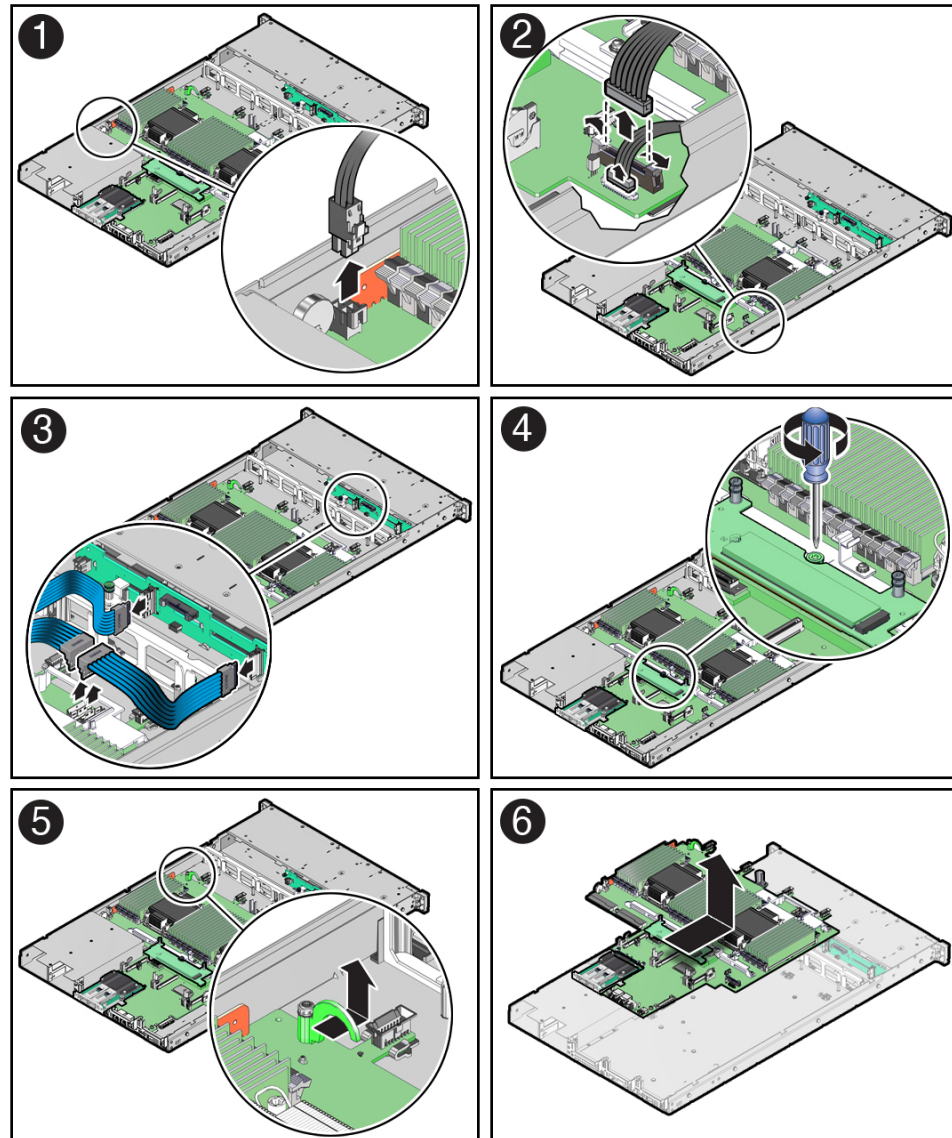

- b. Disconnect the disk backplane data cable by opening the ejectors and pulling out the cable connector [2].
- c. Disconnect the front indicator module (FIM) cable connector by opening the ejectors and pulling out the cable connector [2].
- d. Disconnect the NVMe cables and carefully lift them from the left-side and center cable troughs and set them aside [3].

 **Note:**

You do not need to remove the NVMe cables or the chassis mid-wall when removing the motherboard from the server chassis.

4. Remove the motherboard from the server chassis.
  - a. Using a Torx T25 screwdriver, loosen the green captive screw that secures the motherboard bracket/handle to the server chassis [4].
  - b. Grasp the motherboard handle located just to the rear of the DIMM slots and the finger loop, and then slide the motherboard toward the front of the server and lift it slightly to disengage it from the eight mushroom-shaped standoffs located on the server chassis under the motherboard [5].
  - c. Lift the motherboard out of the server chassis and place it on an antistatic mat and next to the replacement motherboard [6].
5. Remove the following reusable components from the motherboard and install them onto the replacement motherboard.
  - DIMMs  
See [Servicing the DIMMs \(CRU\)](#).

 **Note:**

Install the DIMMs only in the slots (connectors) that correspond to the slots from which they were removed. Performing a one-to-one replacement of the DIMMs significantly reduces the possibility that the DIMMs will be installed in the wrong slots. If you do not reinstall the DIMMs in the same slots, server performance might suffer and some DIMMs might not be used by the server.

- M.2 mezzanine and attached M.2 flash SSDs  
See [Servicing the Internal M.2 Flash SSDs \(CRU\)](#).
  - OCP Network Interface Card  
See [Servicing the OCP Network Interface Card \(FRU\)](#).
6. Remove the processors from the failed motherboard.  
See [Identify and Remove a Processor](#).
  7. Remove the processor socket covers from the replacement motherboard and install the processors.
    - a. Grasp the processor socket cover finger grips (labeled REMOVE) and lift the socket cover up and off the processor socket.







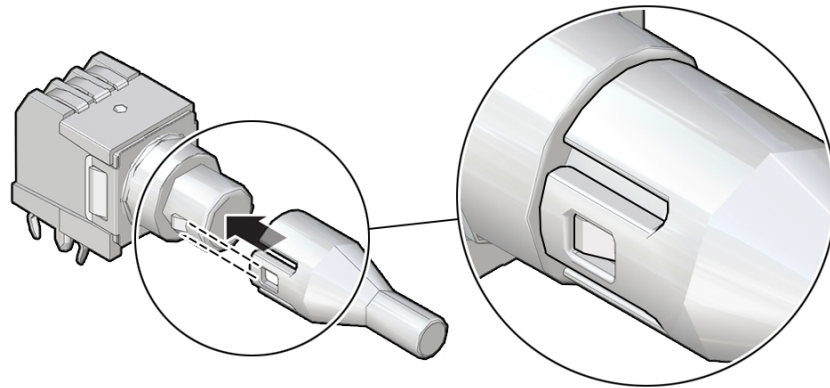

- ii. Push the light pipe onto the housing until the clips latch in the holes.

#### Related Topics

- [Customer-Replaceable Units](#)
- [Field-Replaceable Units](#)
- [Install the Motherboard](#)

## Install the Motherboard

1. Attach an antistatic wrist strap to your wrist, and then to a metal area on the chassis.  
See [Take Antistatic Measures](#).
2. Insert the motherboard into the server chassis.
  - a. Grasp the motherboard handle located to the rear of the DIMMs and the finger grasp, and then tilt the front of the motherboard up slightly and push it into the opening in the rear of the server chassis [1].
  - b. Lower the motherboard into the server chassis and slide it to the rear until it engages the eight mushroom-shaped standoffs located on the server chassis under the motherboard [2].
  - c. Ensure that the indicators, controls, and connectors on the rear of the motherboard fit correctly into the rear of the server chassis.

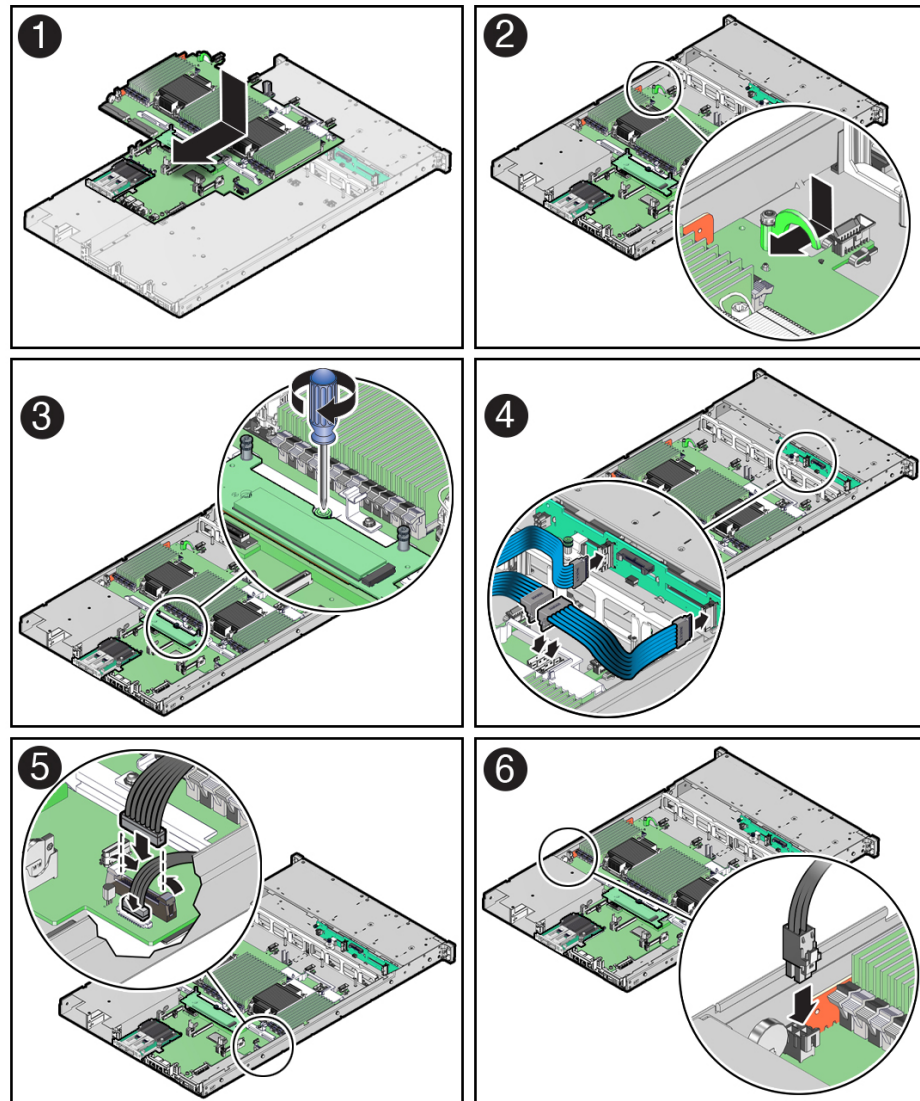

- d. Using a Torx T25 screwdriver, tighten the green captive screw to secure the motherboard bracket/handle to the server chassis [3].
3. Reinstall cables on to the motherboard.
  - a. Carefully reinstall the NVMe cables into the left-side and center cable troughs and then reconnect the cables to the motherboard NVMe connectors [4].
  - b. Reconnect the front indicator module (FIM) cable to the motherboard connector [5].
  - c. Reconnect the disk backplane data cable to the motherboard connector [5].
  - d. Reconnect the disk backplane power cable to the motherboard connector [6].
4. Reinstall the following reusable components:
  - PCIe risers and attached PCIe cards  
See [Servicing PCIe Risers \(CRU\)](#) and [Servicing PCIe Cards \(CRU\)](#).
  - Power supplies

 **Caution:**

When reinstalling power supplies, it is important to reinstall them into the slots from which they were removed during the motherboard removal procedure; otherwise, the server key identity properties (KIP) data might be lost. When a server requires service, the KIP is used by Oracle to verify that the warranty on the server has not expired. For more information on KIP, see [FRU Key Identity Properties \(KIP\) Automated Update](#).

See [Install a Power Supply](#).

- Fan modules

See [Install a Fan Module](#).

- Air baffles

5. Return the server to operation.

- a. Install the server top cover.

See [Install the Server Top Cover](#).

- b. Return the server to the normal rack position.

See [Return the Server to the Normal Rack Position](#).

- c. Reconnect the power cords to the power supplies, and power on the server.

See [Reconnect Data Cables and Power Cords](#) and [Power On the Server](#).

- d. Verify that the System OK status indicator is lit.

 **Note:**

**IMPORTANT:** After replacing the motherboard, you might need to manually program the product serial number (PSN) into the new motherboard. This is necessary because the motherboard is a secondary member of a select group (or quorum) of components used for maintaining the PSN for service entitlement. If you replace more than one of the quorum members during a service procedure, a secondary quorum member might need to be programmed with the PSN. See [FRU Key Identity Properties \(KIP\) Automated Update](#).

**Related Topics**

- [Customer-Replaceable Units](#)
- [Field-Replaceable Units](#)
- [Remove the Motherboard](#)

# Returning the Server to Operation

After replacing components inside of the server, perform the procedures in the following sections:

- [Server Filler Panel Requirements](#)
- [Remove and Install Filler Panels](#)
- [Install the Server Top Cover](#)
- [Remove Antistatic Measures](#)
- [Reinstall the Server Into the Rack](#)
- [Return the Server to the Normal Rack Position](#)
- [Reconnect Data Cables and Power Cords](#)
- [Power On the Server](#)

## Server Filler Panel Requirements

The server might be shipped with module-replacement filler panels for storage drives and PCIe cards. These filler panels are installed at the factory and must remain in the server until you replace them with a purchased option.

Before you can install an optional server component into the server, you must remove the filler panel from the location into which you intend to install the component. When you remove a storage drive or a PCIe card from the server, you must install either a replacement for the component removed or a filler panel.

## Remove and Install Filler Panels

- See the procedures in the following table to remove and install filler panels for storage drives and PCIe cards.

Filler Panel Type	Removal Procedure	Installation Procedure
Storage drive	<ol style="list-style-type: none"> <li>1. Locate the storage drive filler panel to be removed from the server.</li> <li>2. To unlatch the storage drive filler panel, pull the release lever, and tilt the lever out into a fully opened position.</li> <li>3. To remove the filler panel from the slot, hold the opened release lever, and gently slide the filler panel toward you.</li> </ol>	<ol style="list-style-type: none"> <li>1. Locate the vacant storage drive module slot in the server, and ensure that the release lever on the filler panel is fully opened.</li> <li>2. Slide the filler panel into the vacant slot by pressing the middle of the filler panel faceplate with your thumb or finger. The release lever will close as it makes contact with the chassis. Do not slide the filler panel in all the way. Leave the filler panel out approximately 0.25 to 0.50 inch (6 to 12 mm) from the opening.</li> <li>3. Using your thumb or finger, press on the middle of the filler panel faceplate until the release lever engages with the chassis.</li> <li>4. Close the release lever until it clicks into place and is flush with the front of the server</li> </ol>
PCIe slot	<ol style="list-style-type: none"> <li>1. Remove the server top cover.</li> <li>2. To remove the PCIe slot filler panel, rotate the PCIe locking mechanism, and lift and remove the PCIe slot filler panel from the location where you want to install the PCIe card.</li> </ol> <p><b>Note:</b> In single-processor systems, PCIe slot 1 is nonfunctional. Therefore, you do not need to remove the filler panel for slot 1.</p>	<ol style="list-style-type: none"> <li>1. Remove the server top cover.</li> <li>2. Press the PCIe filler panel into the vacant PCIe slot, and rotate the PCIe locking mechanism to secure the PCIe slot filler panel.</li> </ol> <p><b>Note:</b> In single-processor systems, PCIe slot 1 is nonfunctional. The server ships with this filler panel installed.</p>

## Install the Server Top Cover

1. Place the top cover on the chassis [1].

Set the cover down so that it hangs over the back of the server by about 1 inch (25 mm) and the side latches align with the cutouts in the chassis.

2. Check both sides of the chassis to ensure that the top cover is fully down and flush with the chassis.

If the cover is not fully down and flush with the chassis, slide the cover towards the back of the chassis to position the cover in the correct position.

3. Gently slide the cover toward the front of the chassis until it latches into place with an audible click [2].

As you slide the cover toward the front of the server, the release button on the top of the server automatically rotates downward to the closed position. Latch the top cover by pushing down on the button until it is flush with the cover and you hear an audible click. An audible click indicates that the cover is latched.

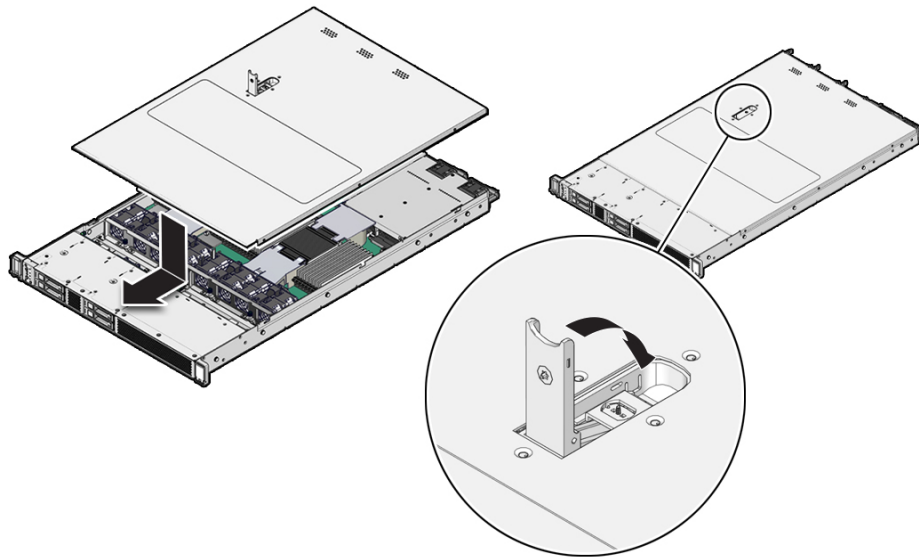

4. Use a Torx T15 screwdriver to turn the release button latch counter-clockwise to the locked position.

#### Related Topics

- [Remove the Server Top Cover](#)

## Remove Antistatic Measures

- Remove any antistatic straps or conductors from the server chassis. removing components antistatic measures

#### Related Topics

- [Take Antistatic Measures](#)

## Reinstall the Server Into the Rack

After servicing the system, reinstall it into the rack.

**▲ Caution:**

Deploy any rack anti-tilt mechanisms before installing the server into the rack.

**▲ Caution:**

The server weighs approximately 35.0 lbs (15.88 kg). Two people are required to carry the chassis and install it into the rack.

1. Lift the server from the antistatic mat, and reinstall the server into the rack.  
For the installation instructions specific to your rackmount kit, refer to *Installing the Server Into a Rack* in *Oracle Servers X9-2 and X9-2L Installation Guide* at [Oracle Server X9-2 Documentation](#).
2. If the cable management arm (CMA) is not installed, because you removed the server completely out of the rack, install the CMA.  
For installation instructions for the CMA, refer to *Install the Cable Management Arm (Optional)* in *Oracle Servers X9-2 and X9-2L Installation Guide* at [Oracle Server X9-2 Documentation](#).
3. If the cables are disconnected from the back of the server, because you removed the server completely out of the rack, reconnect the cables.
  - For instructions to reconnect cables to the back of the server, see [Reconnect Data Cables and Power Cords](#).
  - To identify the location of cable connectors on the back of the server, refer to [Back Panel Connector Locations](#).

**Related Topics**

- [Remove the Server From the Rack](#)
- [Reconnect Data Cables and Power Cords](#)

## Return the Server to the Normal Rack Position

If the server is in the extended maintenance position, use this procedure to return the server to the normal rack position.

1. Push the server back into the rack, as described in the following steps.
  - a. Simultaneously pull and hold the two green release tabs (one on each side of the slide rails on the server) toward the front of the server, while you push the server into the rack.  
Verify that the cable management arm (CMA) retracts without binding.





 **Note:**

If the cable management arm (CMA) is in the way, extend the server approximately 13 cm (5 inches) out of the front of the rack.

2. Reconnect the power cables to the power supplies.
3. If necessary, reinstall the cables into the cable management arm and secure them with Velcro straps.
4. Power on the server.  
See [Power On the Server](#).

**Related Topics**

- [Disconnect Cables From the Server](#)
- [Reinstall the Server Into the Rack](#)
- [Return the Server to the Normal Rack Position](#)
- [Power On the Server](#)

## Power On the Server

As soon as the power cords are connected, Standby power is applied. In Standby power mode:

- The System OK LED on the server front panel blinks slowly.
- The SP OK LED indicator is steady on.
- The AC power supply LED indicator lights are steady on.

Depending on the firmware configuration, the system might boot. If it does not boot, perform the following procedure.

- Power on the server to Main power mode by performing one of the following actions:
  - Press the On/Standby button on the front bezel.
  - Log in to the Oracle ILOM web interface, click Host Management → Power Control, and select Power On from the Select Action list.
  - Log in to the Oracle ILOM command-line interface (CLI), and type the following command at the Oracle ILOM prompt:

```
->  
start /System
```

When the server is powered on to Main power mode and the power-on self-test (POST) code checkpoint tests are complete, the green System OK LED status indicator on the front panel of the server lights and remains lit.

**Related Topics**

- [Powering Down the Server](#)
- [Reconnect Data Cables and Power Cords](#)

# 21

## Identifying the Server Ports

This section describes the pinouts of the server connectors:

- [Gigabit Ethernet Ports](#)
- [Network Management Port](#)
- [Serial Management Port](#)
- [USB Ports](#)

### Gigabit Ethernet Ports

The server has five auto-negotiating gigabit Ethernet (GbE) ports. Three Ethernet ports use standard RJ-45 connectors, and two use enhanced small form-factor pluggable (SFP+) or quad (4-channel) small form-factor pluggable (QSFP) port connectors. The transfer rates are shown in the following table.

**Table 21-1 Ethernet Port Transfer Rates**

Connection Type	IEEE Terminology	Transfer Rate
Gigabit Ethernet	1000BASE-T	1,000 Mbps
10 Gigabit Ethernet	10GBASE-T	10,000 Mbps
10/25 Gigabit Ethernet (SFP+)	10/25GbE	10,000/25,000 Mbps
50/100 Gigabit Ethernet (QSFP)	50/100GbE	50,000/100,000 Mbps

#### Related Topics

- [Back Panel Components and Cable Connections](#)
- [Disconnect Cables From the Server](#)
- [Reconnect Data Cables and Power Cords](#)

### Network Management Port

The server has one 100/1000BASE-T Ethernet management domain interface, labeled NET MGT. For information on configuring this port for managing the server with Oracle ILOM, refer to the [Oracle Integrated Lights Out Manager \(ILOM\) 5.0 Documentation](#).

#### Related Topics

- [Back Panel Components and Cable Connections](#)
- [Disconnect Cables From the Server](#)
- [Reconnect Data Cables and Power Cords](#)

## Serial Management Port

The serial management connector, labeled SER MGT, is an RJ-45 connector that can be accessed from the back panel. This port is the default connection to the server Oracle ILOM SP. Use *only* the SER MGT port for server management.

**Table 21-2 Default Serial Connections for Serial Port**

Parameter	Setting
Connector	SER MGT
Rate	115200 baud
Parity	None
Stop bits	1
Data bits	8

The following figure and table describe the SER MGT port pin signals.



**Table 21-3 Serial Management Port Signals**

Pin	Signal Description	Pin	Signal Description
1	Request to Send	5	Ground
2	Data Terminal Ready	6	Receive Data
3	Transmit Data	7	Data Set Ready
4	Ground	8	Clear to Send

If you need to connect to the SER MGT port using a cable with either a DB-9 or a DB-25 connector, use the pin descriptions in the following tables to create a crossover adapter appropriate for your serial connection.

**Table 21-4 RJ-45 to DB-9 Adapter Crossover Wiring Reference**

Serial Port (RJ-45 Connector) Pin	Serial Port (RJ-45 Connector) Signal Description	DB-9 Adapter Pin	DB-9 Adapter Signal Description
1	RTS	8	CTS
2	DTR	6	DSR
3	TXD	2	RXD
4	Signal Ground	5	Signal Ground
5	Signal Ground	5	Signal Ground

Table 21-4 (Cont.) RJ-45 to DB-9 Adapter Crossover Wiring Reference

Serial Port (RJ-45 Connector) Pin	Serial Port (RJ-45 Connector) Signal Description	DB-9 Adapter Pin	DB-9 Adapter Signal Description
6	RXD	3	TXD
7	DSR	4	DTR
8	CTS	7	RTS

Table 21-5 RJ-45 to DB-25 Adapter Crossover Wiring Reference

Serial Port (RJ-45 Connector) Pin	Serial Port (RJ-45 Connector) Signal Description	DB-25 Adapter Pin	DB-25 Adapter Signal Description
1	RTS	5	CTS
2	DTR	6	DSR
3	TXD	3	RXD
4	Signal Ground	7	Signal Ground
5	Signal Ground	7	Signal Ground
6	RXD	2	TXD
7	DSR	20	DTR
8	CTS	4	RTS

**Related Topics**

- [Back Panel Components and Cable Connections](#)
- [Disconnect Cables From the Server](#)
- [Reconnect Data Cables and Power Cords](#)

## USB Port

The server has a single USB port located on the server back panel for attaching supported USB 3.0-compliant devices.

**Related Topics**

- [Back Panel Components and Cable Connections](#)
- [Disconnect Cables From the Server](#)
- [Reconnect Data Cables and Power Cords](#)

# Setting Up BIOS Configuration Parameters

This section provides an overview of BIOS configuration management, UEFI BIOS, and the BIOS Setup Utility:

- [Manage the BIOS Configuration](#)
- [Accessing the BIOS Setup Utility](#)
- [Using UEFI BIOS](#)
- [Common BIOS Setup Utility Tasks](#)

## Related Topics

- [BIOS Setup Utility Menus](#)

## Manage the BIOS Configuration

The BIOS configuration parameters on an Oracle x86 server are manageable from the BIOS Setup Utility and Oracle ILOM. For information about using these tools to manage the BIOS configuration, refer to:

- **Oracle ILOM** – “Maintaining x86 BIOS Configuration Parameters” in the *Oracle ILOM Administrator's Guide for Configuration and Maintenance Firmware Release 5.0* at [Oracle Integrated Lights Out Manager \(ILOM\) 5.0 Documentation](#).
- **BIOS Setup Utility** – [Common BIOS Setup Utility Tasks](#)

## Accessing the BIOS Setup Utility

The BIOS Setup Utility allows you to view product information, and to configure, enable, and disable, or manage system components.

This section provides the following information:

- [BIOS Setup Utility Menus](#)
- [BIOS Key Mappings](#)
- [Access BIOS Setup Utility Menus](#)
- [Navigate BIOS Setup Utility Menus](#)

## BIOS Setup Utility Menus

The following table provides descriptions for the top-level BIOS Setup Utility menus.

Menu	Description
Main	View general BIOS information, including version, build date and time, platform and processor, memory, and system date and time.
Advanced	Configure NVMe, network stack, PCI subsystem, SATA, disk freeze lock, processor, MD SSD and USB port, Intel platform, Intel socket, CPU, RAM disk, iSCSI, and driver health.
IO	Configure internal I/O devices, add-in cards, and PCIe connectors.
Security	Configure secure boot.
Boot	Configure the retry boot list, network boot retry, boot option priorities.
Save & Exit	Save changes and exit, discard changes and exit, discard changes, or restore the default BIOS settings.

#### Related Topics

- [Navigate BIOS Setup Utility Menus](#)

## BIOS Key Mappings

When viewing the BIOS output from a terminal using the serial console redirection feature, some terminals do not support function keys. BIOS supports the mapping of function keys to Control key sequences when serial redirection is enabled. The following table provides a description of the function key to Control key sequence mappings.

Function Key	Control Key Sequence	BIOS Setup Function
F1	Ctrl+Q	Activate the Setup Utility Help menu.
F2	Ctrl+E	Enter BIOS Setup Utility while the system is performing power-on self-test (POST).
F8	Ctrl+P	Activate the BIOS Boot Menu.
F10	Ctrl+S	Save and Exit changes.
F12	Ctrl+N	Activate Network boot.

#### Related Topics

- [Access BIOS Setup Utility Menus](#)
- [Navigate BIOS Setup Utility Menus](#)

## Access BIOS Setup Utility Menus

You can access the BIOS Setup Utility screens from the following interfaces:

- Use a terminal (or terminal emulator connected to a computer) through the serial port on the back panel of the server.

- Connect to the server using the Oracle ILOM Remote System Console Plus application.
1. server, power on Reset or power on the server.

For example, to reset the server:

- **From the local server**, press the On/Standby button on the front panel of the server to power off the server, and then press the On/Standby button again to power on the server.
  - **From the Oracle ILOM web interface**, click Host Management → Power Control and select Reset from the Select Action list. Click Save, and then click OK.
  - **From the Oracle ILOM CLI**, type `reset /System`
2. After the server resets, to enter the BIOS Setup Utility, press the F2 key (Ctrl+E from a serial connection) when prompted and while the BIOS is running the power-on self-tests (POST).

The BIOS Setup Utility Main Menu screen appears.

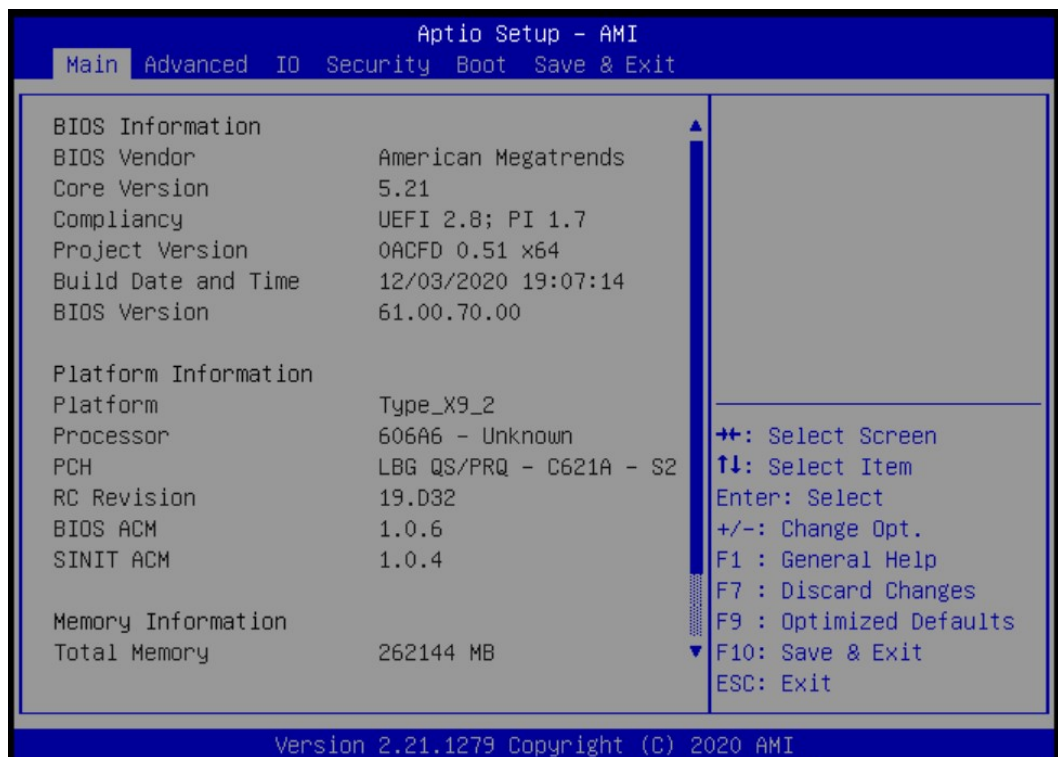

### Related Topics

- [BIOS Setup Utility Menus](#)
- [BIOS Key Mappings](#)

## Navigate BIOS Setup Utility Menus

1. In the BIOS Setup Utility, press the left and right arrow keys to select the menu options. As you select a menu option, the top-level menu for that menu option appears.
2. To navigate options in a top-level menu, press the up and down arrow keys.



Options that you can modify appear highlighted in the menu. User instructions for a selected menu option appear on the upper right side of the screen.

3. Modify an option by pressing the + or - (plus or minus) keys, or by pressing Enter and selecting the option from the menu.

The navigation keys appear on the lower right side of the BIOS screen.

4. Press the Esc key to return from a sub-menu to the previous menu.

Pressing Esc from a top-level menu is equivalent to selecting the Discard Changes and Exit option in the Save Menu.

5. Modify parameters, as needed.
6. Press the F10 key to save your changes and exit the BIOS Setup Utility.

Alternatively, you can select the Save menu, and select Save Changes and Exit to save your changes and exit the BIOS Setup Utility.

 **Note:**

After modifying any BIOS settings, the subsequent reboot might take longer than a typical reboot where you did not change any settings. The delay occurs because the changes to the BIOS settings are synchronized with Oracle ILOM.

**Related Topics**

- [BIOS Setup Utility Menus](#)
- [BIOS Key Mappings](#)

## Using UEFI BIOS

Oracle Server X9-2 has a Unified Extensible Firmware Interface (UEFI)-compatible BIOS, which runs with all operating systems that are supported on the server. The BIOS firmware controls the system from power-on until an operating system is booted and allows you to configure, enable, disable, or manage system components.

This section includes the following information:

- [Configuration Utilities for Add-In Cards](#)
- [Configure and Manage BIOS Using Oracle ILOM](#)
- [UEFI Secure Boot](#)
- [Trusted Execution Technology](#)

## Configuration Utilities for Add-In Cards

In UEFI BIOS, the configuration screens for the add-in cards appear as menu items in the BIOS Advanced Menu as part of the standard BIOS Setup Utility screens. For example, if the Oracle Storage 12 Gb SAS PCIe RAID HBA, Internal card is installed in the server, the configuration utility for the HBA appears as a menu selection.

## Configure and Manage BIOS Using Oracle ILOM

Oracle Integrated Lights Out Manager (ILOM) includes BIOS configuration and management tools. You can perform the following BIOS configuration tasks using Oracle ILOM:

- View the BIOS configuration synchronization status and synchronize the configuration parameters
- Reset the factory defaults for the service processor (SP) and Oracle ILOM BIOS
- Backup or restore the BIOS configuration
- Enable UEFI diagnostics to run at system boot

For more information about Oracle ILOM BIOS configuration and management tools, refer to the [Oracle Integrated Lights Out Manager \(ILOM\) 5.0 Documentation](#).

## UEFI Secure Boot

Oracle Server X9-2 UEFI BIOS supports UEFI Secure Boot. UEFI Secure Boot defines how platform firmware can authenticate a digitally signed UEFI image, such as an operating system loader or a UEFI driver.

When enabled, UEFI Secure Boot provides a policy-based invocation of various UEFI executable images, using cryptographic signatures to identify the software publishers. UEFI Secure Boot also requires all third-party UEFI drivers and operating system boot loaders to be signed by Microsoft or with Key Exchange Key (KEK) by using BIOS setup.

UEFI Secure Boot is disabled by default. For configuration information, see [Configure UEFI Secure Boot](#).

## Trusted Execution Technology

Oracle Server X9-2 uses Trusted Execution Technology (TXT), which provides authenticity of a platform and its operating system.

When enabled, TXT ensures that the operating system (OS) starts in a trusted environment, and provides the OS with additional security capabilities not available to an untrusted OS. Using cryptographic techniques, TXT provides measurements of software and platform components so that system software as well as local and remote management applications may use those measurements to make trust decisions. Trusted Execution Technology defends against software-based attacks aimed at stealing sensitive information by corrupting system or BIOS code, or modifying a platform's configuration.

Trusted Execution Technology is disabled by default. For configuration information, see [Configure Trusted Execution Technology](#).

## Common BIOS Setup Utility Tasks

This section presents the procedures for some of the BIOS setup tasks that you typically perform when setting up and managing the server.

For additional information about BIOS setup tasks, refer to the *Oracle X9 Series Servers Administration Guide* at [Oracle x86 Servers Administration, Diagnostics, and Applications Documentation](#).

- [Verify BIOS Factory Default Settings](#)
- [Select a Temporary Boot Device](#)
- [Configure TPM Support](#)
- [Configure UEFI Driver Settings](#)
- [Configure I/O Resource Allocation](#)
- [Configure UEFI Secure Boot](#)
- [Configure Trusted Execution Technology](#)
- [Exit BIOS Setup Utility](#)

## Verify BIOS Factory Default Settings

In the BIOS Setup Utility, you can return the BIOS settings to the optimal factory default values, as well as view and edit settings as needed. Any changes that you make in the BIOS Setup Utility (using the F2 key) persist until the next time you change the settings.

1. Ensure that a console connection is established to the server.
2. Reset or power on the server.

For example, to reset the server:

- **From the local server**, press the On/Standby button on the front panel of the server to power off the server, and then press the On/Standby button again to power on the server.
  - **From the Oracle ILOM web interface**, click Host Management → Power Control and select Reset from the Select Action list. Click Save, and then click OK.
  - **From the Oracle ILOM CLI**, type `reset /System`
3. After the server resets and begins the initialization process, when prompted, press the F2 key to access the BIOS Setup Utility.
  4. To ensure that the factory defaults are set, do the following:
    - a. Press the F9 key to automatically load the optimal factory default settings.
    - b. To confirm, highlight OK, and press Enter.
  5. Press the F10 key to save the changes and exit the BIOS Setup Utility.

### Related Topics

- [Access BIOS Setup Utility Menus](#)
- [BIOS Setup Utility Menus](#)
- [BIOS Key Mappings](#)
- [Exit BIOS Setup Utility](#)

## Select a Temporary Boot Device

1. Reset or power on the server.  
For example, to reset the server:

- **From the local server**, press the On/Standby button on the front panel of the server to power off the server, and then press the On/Standby button again to power on the server.
  - **From the Oracle ILOM web interface**, click Host Management → Power Control and select Reset from the Select Action list. Click Save, and then click OK
  - **From the Oracle ILOM CLI**, type `reset /System`
2. After the server resets and begins the initialization process, press the F8 key (or Ctrl+P from a serial connection) when prompted, while the UEFI BIOS is running the power-on self-test (POST) to access the boot device menu.
  3. In the Please Select Boot Device dialog box, select the boot device according to the operating system you are running, and press Enter.  

The boot device you select is in effect only for the current system boot. The permanent boot device specified using the F2 key is in effect after booting from the temporary boot device.
  4. Follow the onscreen instructions to install the operating system from the selected boot device.

#### Related Topics

- [Access BIOS Setup Utility Menus](#)
- [BIOS Setup Utility Menus](#)
- [BIOS Key Mappings](#)
- [Exit BIOS Setup Utility](#)

## Configure TPM Support

The Trusted Platform Module (TPM) feature set is enabled by default. If you want to disable it, or to enable it after it has been disabled, perform the procedure in this section.

#### Note:

TPM enables you to administer the TPM security hardware in your server. For additional information about implementing this feature, refer to the Windows Trusted Platform Module Management documentation provided by your operating system or third-party software vendor.

If you intend to use the TPM, configure the server to support TPM, which is enabled by default on Oracle Server X9-2.

1. Access the BIOS Setup Utility menus.  
See [Access BIOS Setup Utility Menus](#).
2. Navigate to the Security Menu.
3. On the Advanced Menu screen, select Trusted Computing 2.0.
4. On the Trusted Computing 2.0 Configuration screen, select Security TPM Device Support and press Enter. Do one of the following:
  - Select `Disable` to disable Security TPM Device Support.

- Select `Enable` to enable Security TPM Device Support.
5. On the updated Trusted Computing 2.0 Configuration screen, press the F10 key to save the changes and exit the BIOS Setup Utility.

#### Related Topics

- [Access BIOS Setup Utility Menus](#)
- [BIOS Setup Utility Menus](#)
- [Exit BIOS Setup Utility](#)

## Configure UEFI Driver Settings

1. Access the BIOS Setup Utility menus.  
See [Access BIOS Setup Utility Menus](#).
2. In the BIOS Setup Utility menus, navigate to the IO Menu.
3. On the IO Menu screen, select either Internal Devices or Add In Cards and press Enter to display the internal device or add-in card slot for which you want to enable or disable the PCI-E UEFI Driver.
4. On the Internal Devices screen, select the internal device or add In card slot that you want to configure.
5. On the PCI-E UEFI Driver Enable screen, select PCI-E UEFI Driver Enable and press Enter. Do one of the following:
  - Select `Enabled` to enable the PCI-E UEFI Driver setting.
  - Select `Disabled` to disable the PCI-E UEFI Driver setting.
6. Press the F10 key to save the changes and exit the BIOS Setup Utility.

#### Related Topics

- [Access BIOS Setup Utility Menus](#)
- [BIOS Setup Utility Menus](#)
- [Exit BIOS Setup Utility](#)

## Configure I/O Resource Allocation

1. Access the BIOS Setup Utility menus.  
See [Access BIOS Setup Utility Menus](#).
2. In the BIOS Setup Utility menus, navigate to the IO Menu.
3. On the IO Menu screen, select Add In Cards and press Enter to display the add-in card slots.
4. On the Add In Cards screen, select the slot in which you want to configure the card and press Enter.
5. On the IO resource allocation screen for that card, select IO Enable and press Enter. Do one of the following:
  - Select `Enabled` to enable I/O resource allocation for the I/O card.
  - Select `Disabled` to disable I/O resource allocation for the I/O card.

6. Press the F10 key to save the changes and exit the BIOS Setup Utility.

#### Related Topics

- [Access BIOS Setup Utility Menu](#)
- [BIOS Setup Utility Menu](#)
- [Exit BIOS Setup Utility](#)

## Configure UEFI Secure Boot

1. Access the BIOS Setup Utility menus.  
See [Access BIOS Setup Utility Menu](#).
2. On the Main Menu screen, select Security and press Enter.
3. On the Security Settings screen, select Secure Boot and press Enter.
4. On the Secure Boot screen, select Attempt Secure Boot and press Enter. Do one of the following:
  - Select `Enabled` to enable UEFI Secure Boot. Continue with the next step to manage policy variables.
  - Select `Disabled` to disable UEFI Secure Boot. Continue with [Step 8](#) to save changes and exit from the BIOS Setup Utility.

When enabled, Secure Boot allows you to manage Secure Boot policy variables.

5. To manage Secure Boot policy variables, select Key Management and press Enter.  
The Key Management screen provides options to provision factory default Secure Boot keys or to enroll an Extensible Firmware Interface (EFI) image.
  - To provision factory default keys – See [Step 6](#).
  - To enroll an EFI image – See [Step 7](#).
6. If you want to provision factory default keys, select Factory Key Provision and press Enter. Do one of the following:
  - Select `Enabled` to allow the provisioning of factory default Secure Boot keys when the system is in Setup Mode. When enabled, you can select `Restore Factory Keys` to force the system to User Mode and install all the factory default Secure Boot keys.
  - Select `Disabled` to disable the provisioning of factory default Secure Boot keys. When disabled, you can select `Delete all Secure Boot Variables` to remove all Secure Boot keys from the system. Selecting this option also resets the system to Setup Mode.
7. If you want to enroll an EFI image, select Enroll Efi Image and press Enter.
  - a. On the Select a File System screen, scroll through the list and select the file system that contains the EFI file, and press Enter.
  - b. On the Select File screen, scroll through the list and select the EFI file (or another available file), and press Enter.
  - c. On the next Select File screen, scroll through the list and select the image file that you want to run in Secure Boot mode, and press Enter.
  - d. To save all Secure Boot policy variables, select Save all Secure Boot variables and press Enter.

- e. On the Select a File System screen, select the file system where you want to save the EFI file, and press Enter.

The Secure Boot policy variables are saved to the root folder in the target file system.

8. Press the F10 key to save the changes and exit the BIOS Setup Utility.

#### Related Topics

- [Access BIOS Setup Utility Menus](#)
- [BIOS Setup Utility Menus](#)
- [UEFI Secure Boot](#)
- [Exit BIOS Setup Utility](#)

## Configure Trusted Execution Technology

1. Verify that TPM is enabled.
2. Access the BIOS Setup Utility menus.  
See [Access BIOS Setup Utility Menus](#).
3. On the Main Menu screen, select Advanced, and press Enter.
4. On the Advanced screen, select Intel Socket Configuration, and press Enter.
5. On the Intel Socket Configuration screen, select Enable Intel(R) TXT and press Enter. Do one of the following:
  - Select `Enabled` to enable TXT.
  - Select `Disabled` to disable TXT.
6. Press the F10 key to save the changes and exit the BIOS Setup Utility.

#### Related Topics

- [Access BIOS Setup Utility Menus](#)
- [BIOS Setup Utility Menus](#)
- [Trusted Execution Technology](#)
- [Configure TPM Support](#)
- [Exit BIOS Setup Utility](#)

## Exit BIOS Setup Utility

1. Use the left and right arrow keys to navigate to the top-level Save & Exit Menu.
2. Use the up and down arrow keys to select an action.
3. Press Enter to select the option.
4. In the confirmation dialog box, select Yes to proceed and exit the BIOS Setup Utility, or select No to stop the exit process.

 **Note:**

After modifying any BIOS settings, the subsequent reboot might take longer than a typical reboot where no settings were modified. The additional delay is required to ensure that changes to the BIOS settings are synchronized with Oracle ILOM.

**Related Topics**

- [Access BIOS Setup Utility Menus](#)
- [BIOS Setup Utility Menus](#)



# 23

## BIOS Setup Utility Menu Options

This section includes screens of the main menus in the BIOS Setup Utility for Oracle Server X9-2. Following the screen for each menu is a table of the options available from that menu.



### Note:

For more information on the BIOS Setup Utility, refer to the *Oracle X9 Series Servers Administration Guide* at: [Oracle x86 Servers Administration, Diagnostics, and Applications Documentation](#).

- [Main Menu](#)
- [Advanced Menu](#)
- [IO Menu](#)
- [Security Menu](#)
- [Boot Menu](#)
- [Exit Menu](#)

### Related Topics

- [Setting Up BIOS Configuration Parameters](#)

## Main Menu

Main Menu Option	Description
<b>BIOS Information</b>	
BIOS Vendor	American Megatrends
Core Version	Core version number for a specific release. Format is XX.YY, where: <ul style="list-style-type: none"><li>• XX - Core major release.</li><li>• YY - Core minor release.</li></ul> Example: 5.20
Compliance	Compliance version number for a specific release. Format is UEFI version number and Platform Initialization (PI) version number. Example: UEFI 2.8; PI 1.7
Project Version	BIOS project version number for a specific release. Example: 0ACFD 0.47 X64
Build Date and Time	The date and time the build for the BIOS version was created.

Main Menu Option	Description
BIOS Version	BIOS release version. Format is XXYYZZPP, which indicates: <ul style="list-style-type: none"> <li>XX - Unique project/platform code.</li> <li>YY - BIOS major release.</li> <li>ZZ - BIOS minor release.</li> <li>PP - Build number.</li> </ul> Example: 62.00.64.01
<b>Platform Information</b>	
Platform	Server platform type. Example: X9-2L
Processor	Processor type. Example: 606A0 – ICX L0
PCH	Platform Controller Hub. Example: LBG QS/PRQ – C621A – S2
RC Revision	Reference Code revision number. Example: 18.D52
BIOS ACM	Authenticated code module number for using Intel Trusted Execution Technology (TXT). Example: 1.0.3
SINIT ACM	Authenticated code module number for using Intel Trusted Execution Technology (TXT). Example: 1.0.3
<b>Memory Information</b>	
Total Memory	Total amount of memory in megabytes. Example: 65536 MB
System Date	Allows you to change the current system date. Example: Thu 06/20/2021
System Time	Allows you to change the current system time. Example: 13:38:27

## Advanced Menu

The following section provides descriptions for the Advanced menu.

### Trusted Computing 2.0 Options



**Note:**

The Trusted Computing 2.0 options are available only when you enable the Security TPM Device Support option.

Setup Options	Description
TPM 2.0 Device Found	Displays the firmware version and vendor for the TPM device.

Setup Options	Description
Security TPM Device Support	Enable (default) or disable Trusted Platform Module (TPM) support. If disabled, the OS will not show TPM. Reset of the platform is required.
Active PCR banks	Displays active Platform Configuration Register (PCR) banks.
Available PCR banks	Displays available Platform PCR banks.
SHA-1 PCR Bank	Displays if the SHA-1 PCR bank is enabled (default) or disabled.
SHA256 Bank	Displays if the SHA256 PCR bank is enabled (default) or disabled.
Pending Operation	Schedule an operation for the security device. <b>Note:</b> Your computer reboots during restart to change the state of a security device. None (default), TPM Clear
Platform Hierarchy	Enable (default) or disable platform hierarchy.
Storage Hierarchy	Enable (default) or disable storage hierarchy.
Endorsement Hierarchy	Enable (default) or disable endorsement hierarchy.
TPM 2.0 UEFI Spec Version	Displays the TPM 2.0 UEFI spec version. Example: TCG_2
Physical Presence Spec Version	Select the physical presence spec version. 1.2, 1.3 (default)
TPM 20 Interface Type	Displays the TPM 20 interface type. Example: TIS
Display Block SID	Enable override to allow SID authentication in TCG storage device. Default is Disable.

## Serial Port Console Redirection

Serial Port Console Redirection Option	Description
<b>COM0 Console Redirection Settings</b>	
Console Redirection EMS	Enable (default) or disable console redirection EMS.
Console Redirection	Enable (default) or disable console redirection.
Terminal Type	VT100, VT100+ (default), VT-UFT8, ANSI
Bits Per Second	9600, 19200, 38400, 57600, 115200 (default)
Data Bits	7, 8 (default)
Parity	None (default), Even, Odd, Mark, Space
Stop Bits	1, 2 (default)
Flow Control	None (default), Hardware, RTS/CTS

## NVMe Configuration

NVMe Configuration Option	Description
NVMe Configuration	Displays the model number, size, vendor ID, device ID, and namespace for the NVMe controller.
NVMe Device Self Test	Allows you to change the type of self test, Short (default) or Extended, change the self test action, Controller Only Test (default) or Controller and Namespace, and run a self test based on the option and action you selected.

## Network Stack Configuration

Network Stack Option	Description
Network Stack	Enables (default) the UEFI network stack and prevents users from performing single-user network boots and network installations. If disabled, the host does not use the network interface.
IPv4 PXE Support	Enables (default) IPv4 PXE Boot support. If disabled, the IPv4 PXE Boot Option is not supported.
IPv4 HTTP Support	Enables IPv4 HTTP Boot support. If disabled (default), the IPv4 HTTP Boot Option is not supported.
IPv6 PXE Support	Enables IPv6 PXE Boot support. If disabled (default), the IPv6 PXE Boot Option is not supported.
IPv6 HTTP Support	Enables IPv6 HTTP Boot support. If disabled (default), the IPv6 HTTP Boot Option is not supported.
PXE Boot Wait Time	Specifies the wait time to press the ESC key to abort the PXE boot. Default is 0.
Media Detect Count	Specifies the number of times the presence of physical storage devices are verified on a system reset or power cycle. Default is 1.

## PCI Subsystem Settings

PCI Subsystem Option	Description
PCI Driver Version	Version number of the PCI driver. Example: A5.01.23
<b>PCI Settings Common for All Devices</b>	<b>Caution:</b> If you change the PCI settings common to all devices, there might be unwanted results, such as the system might freeze.
Above 4G Decoding	Enable (default) or disable above 4G decoding.
SR-IOV Support	Enable (default) or disable Single Root I/O Virtualization (SR-IOV) to configure devices into multiple virtual devices that can be used on virtual OS installations. If supported by the hardware and set to enabled, all devices on the system that are SR-IOV capable are configured to support SR-IOV and I/O resources are allocated to the device as normal. If set to disabled, I/O resources are not allocated to the device.

PCI Subsystem Option	Description
BME DMA Mitigation	Enable or disable (default) Bus Master Attribute that is disabled after PCI enumeration for PCI bridges after SMM is locked.

## SATA Configuration

SATA Configuration Option	Description
SATA Controller	Displays the SATA controller BUS device and function, and installed media devices.

## Disk Freeze Lock

Disk Freeze Lock Settings Option	Description
Disk Freeze Lock Settings	
Disk Freeze Lock	Enables or disables (default) disk freeze lock, which prevents disks from being sanitized. Disk types include NVMe and M.2.

## Processor Configuration

Processor Configuration Option	Description
Active Processor Cores	Number of cores to enable in each processor package. A minimum of one core up to the maximum number of cores are available in the processor package. All (default)

## Intel Platform Configuration

Intel Platform Option	Description
<b>PCH Configuration</b>	
SATA Controller	Enable (default) or disable the SATA controller.
Configure SATA As	Identify the type of SATA controller configuration. RAID, AHCI (default)
<b>Miscellaneous Platform Configuration</b>	
ARI Support	If Alternate Routing ID (ARI) is supported by the hardware and set to enabled (default), devices are permitted to locate virtual functions (VFs) in function numbers 8 to 255 of the captured bus number, instead of normal function numbers 0 to 7.
ARI Forward	Enable (default) or disable ARI forward.
<b>Runtime Error Logging</b>	
Error Injection Settings	Enable or disable (default) Windows Hardware Error Architecture (WHEA), which discovers errors and preserves the error records.

## Intel Socket Configuration

Intel Socket Option	Description
<b>Processor Configuration</b>	
Enable Intel(R) TXT	Enable or disable (default) Intel Trusted Execution Technology (TXT), which ensures that an installed OS is verified and considered secure.
VMX	Enable (default) or disable VMX.
Enable SMX	Enable SMX. Disable is the default.
Hyper-Threading (ALL)	Enable (default) or disable Hyper Threading. When enabled, two threads are available per enabled core. When disabled, only one thread per enabled core is available.
Extended APIC	Enable or disable (default) extended APIC.
Limit CPU PA to 46 Bits	Enable (default) or disable limiting the CPU PA to 46 bits.
<b>Common RefCode Configuration</b>	
NUMA	Enable (default) or disable non-uniform memory access (NUMA) for faster memory access, where memory is local to the processor and not controlled by a different processor.
Total Memory Encryption (TME)	Enable or disable (default) total memory encryption (TME).
UMA-Based Clustering	Disable (All2All), Hemisphere (2-clusters (default))
Mirror Mode	Enable or disable (default) Mirror mode.
Durability Domain	Memory Controller (default), CPU Cache Hierarchy
CPU Flex Ratio Override	Enable or disable (default) CPU flex ratio override.
CPU Core Flex Ratio	Default ratio is 0.
Publish SRAT	Enable (default) or disable publishing SRAT.
Attempt Fast Boot	Enable (default) or disable attempting a fast boot.
Attempt Fast Cold Boot	Enable (default) or disable attempting a fast cold boot.
<b>I/O Configuration</b>	
Intel VT for Directed I/O (VT-d)	Intel Virtualization Technology for directed I/O (VT-d) reports the I/O device assignment to VMM through DMA remapping reporting (DMAR) Advance Configuration Power Interface (ACPI) tables. Yes (default) or No.

Intel Socket Option	Description
Intel VMD technology	Enable or disable (default) Intel Volume Management Device for sockets and IOUs.
EV DFX Features	Enable to expose IIO DFX or other CPU devices such as PMON, or disable (default).
PCIe Max Read Request Size	Set the maximum read request size in Endpoints to Auto (default), 128B, 256B, 512B, 1024B, 2048B, or 4096B.
<b>Memory Configuration</b>	
NGN Configuration	Enable or disable (default) the Next Generation Network factory settings.
Volatile Memory Mode	Select whether 1LM or 2LM memory mode must be enabled for Data Center Persistent Memory Modules (DCPMMs). <ul style="list-style-type: none"> <li>• 1LM</li> <li>• 2LM</li> <li>• Auto (default)</li> </ul>
Memory Frequency	Specify the maximum memory frequency as Auto (default), or select a value in MHz based on DIMM support.
Turnaround Time Optimization PMEM	Enable (default) or disable the turnaround time for optimizing PMEM.
Multi-Threaded MRC	Enable (default) or disable multi-threaded Memory Reference Code.
Secure Erase DIMMs	Enable or disable (default) securely erasing the persistent memory region of all PMEM in the system.
200 Series PMEM Average Power Limit (in Mw)	Specify the power limit used for average power in milliwatts (Mw). Starts from 10000 Mw in increments of 250 mw. Default is 15000 Mw.
<b>Advanced Power Management Configuration</b>	
CPU P State Control	Enable (default) or disable Turbo Mode, and set the boot performance for BIOS before handoff to the operating system to Max Performance (default), Max Efficient, or Set by Intel Node Manager. <b>Note:</b> When you enable Turbo Mode, you also must enable Enhanced Multi Threaded Thermal Monitoring (EMTTM).
Package C State Control	Specify the Package C-State to C0/C1 state, C2 state, C6 (non Retention) state, Auto (default)
Turbo Ratio Limit <X>	Specify the turbo ratio limit MSR 0x1AD for 0-7 limits. Default is 0.
Turbo Ratio Cores <Y>	Specify the number of cores for the turbo ratio MSR 0x1AE for 0-7 cores. Default is FF.

## MD SSD Ports Configuration

MD SSD Ports Configuration Option	Description
MD SSD Ports Configuration	

MD SSD Ports Configuration Option	Description
Onboard SSD	Enable (default) or disable the onboard MD SSD ports.

## USB Port

USB Port Option	Description
Rear Port	Enable (default) or disable the USB rear port.

## All CPU Information

All CPU Information Option	Description
Total CPU Number	Total number of CPUs on the server.
CPU (xxx)	Displays the number of the CPU thread.
CPUID	Displays the CPU ID. Example: 000606A0
Stepping	Displays the revision number for the CPU.
Microcode Rev	Displays the revision number for the microcode.
Platform ID	Displays the ID for the platform.
CPU Core Freq (MHz)	Displays the core frequency for the CPU in MHz.
Actual CPU Freq (MHz)	Displays the actual frequency for the CPU in MHz.

## RAM Disk Configuration

RAM Disk Configuration Option	Description
Disk Memory Type	Specifies the type of memory to use from the available memory pool in system to create a disk. Boot Service Data (default) Reserved
Create raw	Creates a blank RAM disk by allocating a portion of the host memory to appear as a disk, which is a bootable image if the disk contains a valid boot image.
Create from file	Creates a RAM disk from a file you select. Select Storage Device
Remove Selected RAM Disk(s)	Removes the selected RAM disk(s).



## iSCSI Configuration

iSCSI Configuration Option	Description
iSCSI Initiator Name	Worldwide unique name of the iSCSI Initiator. Only the iSCSI Qualified Name (IQN) format is accepted. None (default) NA (must be specified)
Add an Attempt	
iSCSI Attempt Name	Human-readable name for the iSCSI attempt, where the name is an alias that simplifies the boot process. None (default) NA (must be specified)
iSCSI Mode	Set to Enabled or Enabled for multipath I/O (MPIO). MPIO can boost the performance of an application by load-balancing traffic across multiple ports. Disabled (default)/Enabled/Enabled for MPIO
Internet Protocol	Can be set to IP4, IP6, or Autoconfigure. The initiator IP address is assigned by the system to IP6. In Autoconfigure mode, the iSCSI driver attempts to connect to the iSCSI target using the IPv4 stack. If this fails, then the iSCSI driver attempt to connect using the IPv6 stack. IP4 (default)/IP6/Autoconfigure
Connection Retry Count	Count range is 0 (default) to 16. If set to 0, there are no retries. 0 to 16
Connection Establishing Timeout	Timeout value in milliseconds. Minimum is 100 milliseconds and maximum is 20 seconds. NA 1,000 (default)
Configure ISID	iSCSI Session IDentifier (ISID) specifies the iSCSI initiator during login. OUI-format ISID is 6 bytes. Default value is derived from the MAC address. Only the last 3 bytes are configurable. Example: Update 0ABBCCDDEEFF to 0ABBCCF07901 by inputting F07901
Enable DHCP	Enable or disable (default) DHCP.
Initiator IP Address	Set initiator IP address in dotted-decimal notation. 0.0.0.0 (default)
Initiator Subnet Mask	Set initiator subnet mask IP address in dotted-decimal notation. 0.0.0.0 (default)
Gateway	Set initiator gateway IP address in dotted-decimal notation. 0.0.0.0 (default)
Target Name	Worldwide unique name of the target. Only IQN format is accepted.
Target IP Address	Set target IP address in dotted-decimal notation. For example, 0.0.0.0. None (default)

iSCSI Configuration Option	Description
Target Port	Change target port number. 3260 (default)
Boot LUN	Set the hexadecimal representation of the boot logical unit number (LUN). Example: 4752-3A4F-6b7e-2F99 0 (default)
Authentication Type	Define the Challenge-Handshake Authentication Protocol (CHAP). CHAP (default)/None
CHAP Type	Set CHAP type to either One Way or Mutual. One Way (default)/Mutual
CHAP Name	Set CHAP name. None (default)
CHAP Secret	Set the CHAP secret password. The secret length range is 12 to 16 bytes. None (default)
Delete Attempts	Delete one or more attempts.
Change Attempt Order	Change the order of attempts. Use arrow keys to select the attempt, then press plus or minus (+/-) keys to move the attempt up/down in the attempt order list.

## Driver Health



### Note:

Depending on the devices that populate the PCIe slots, some devices display their driver health status.

Menu Driver Health Option	Description
Mellanox ConnectX Driver	Displays the health status of Mellanox ConnectX driver. Healthy (default)
Intel PRO/1000 PCI-E	
Broadcom NXE Gigabit Ethernet Driver Health	Displays the health status of the Broadcom NXE gigabit Ethernet driver. Healthy (default)
Intel DCPMM Driver Health	Displays the health status of Intel DCPMM driver. Healthy (default)
AVAGO EFI SAS Driver Health	Displays the health status of the AVAGO EFI SAS driver. Healthy (default)

## Intel VROC SATA Controller

Intel VROC SATA Controller Option	Description
Intel VROC SATA Driver	Displays the RAID driver name.
Create RAID Volume	Allows you to create a RAID volume, including a volume name and level. You can assign disks to ports, and specify the stripe size and capacity.
Non-RAID Physical Disks	Allows you to assign non-raid disks to ports.

## Intel Virtual RAID on CPU

Intel Virtual RAID on CPU Option	Description
Intel VROC Managed Controllers	Allows you to manage virtual RAID on the CPU.
All Intel VMD Controllers	Allows you to create a RAID volume and view the non-RAID physical disks.
Create RAID Volume	Allows you to create a RAID volume name, select a RAID stripe level, enable RAID spanned over VMD controllers, and select disks.

## IO Menu

This section provides descriptions of the IO Menu.

### Internal Devices

Internal Devices Option	Description
NET0	Displays and provides options to change the internal device settings.
PCI-E UEFI Driver Enable	Enable (default) or disable PCI-E UEFI Driver. If set to enabled, UEFI Driver for the card executes as normal. If set to disabled, UEFI Driver for the card is not copied into memory and the execution of the UEFI Driver is inhibited.

### Add-in Cards

Add-in Cards Option	Description
Slot 1-Slot 3	Displays and provides options to change the settings of the devices in PCIe slots. <b>Note:</b> For each physical slot, there could be two or four slot numbers available, depending on the add-in cards.
PCIe UEFI Driver Enable	Enable (default) or disable PCI-E UEFI Driver. If set to enabled, UEFI Driver for the card executes as normal. If set to disabled, UEFI Driver for the card is not copied into memory and the execution of the UEFI Driver is inhibited.
Slot 5	Displays the internal PCIe slot.

Add-in Cards Option	Description
Slot 100-Slot 103	Displays the slot numbers for SSDs on the front panel.

## PCIe Connector Configuration Settings

PCIe Connector	Description
PCIe Connector Configuration	Specify the connector to control PCIe bifurcation and hotplug.

## Security Menu

Security Menu Option	Description
<b>HDD Security Configuration</b>	
<b>Secure Boot</b>	
System Mode	Secure Boot is activated when Platform Key (PK) is enrolled, System mode is User (default) or Deployed, and the Compatibility Support Module (CSM) function is disabled.
Attempt Secure Boot	When enabled (default), Secure Boot is activated when Platform Key (PK) is enrolled, System mode is User or Deployed, and the Compatibility Support Module (CSM) function is disabled.
Secure Boot Mode	Specifies Standard or Custom (default) Secure Boot mode.
Restore Factory Keys	Forces system to User mode. Installs factory default Secure Boot key databases.
Reset to Setup Mode	Removes platform key and resets system to Setup mode.
Enter Audit Mode	Resets the system to Audit Mode and erases the PK variable.
Key Management	
Factory Key Provision	Disables (default) provisioning factory default Secure Boot keys when the system is in Setup Mode.
Restore Factory Keys	Forces system to User mode. Installs factory default Secure Boot key databases.
Export Secure Boot variables	Select a file system to copy the NVRAM content of Secure Boot variables to files in a root folder on a file system device.
Enroll EFI Image	Enrolls an EFI image to run in Secure Boot mode.
Secure Boot Variable   Size   Keys   Key Source	Displays the size, platform keys, key exchange keys, and signatures.
<b>Image Execution Policy</b>	
Option ROM	Deny Execute (default), Query User

Security Menu Option	Description
Removable Media	Deny Execute (default), Query User
Fixed Media	Deny Execute (default), Query User

## Boot Menu

Boot Menu Option	Description
Retry Boot List	Disable or enable (default) automatic retries of the Boot List when all devices fail.
Network Boot Retry	If enabled (default), BIOS automatically retries the PXE list present in the system when all PXE attempts have failed. If set to disabled, the system halts and displays the error message "Network Boot Failed" when all PXE boots fail. If set to Boot List, fail over to the main Boot Options Priority list.
Boot Option Priorities	Displays and sets the system boot order.

## Exit Menu

Save and Exit Option	Description
Save Changes and Exit	Save changes and exit the BIOS Setup Utility.
Discard Changes and Exit	Exit the BIOS Setup Utility without saving changes.
Discard Changes	Discard any changes made to the setup options.
Restore Defaults	Restore and load the optimal default values for all of the setup options.

# Monitoring Components and Identifying SNMP Messages

This section includes information about monitoring components and identifying SNMP messages for Oracle Server X9-2.

- [Monitoring Component Health and Faults Using Oracle ILOM](#)
- [Monitoring System Components](#)
- [Identifying SNMP Trap Messages](#)

## Monitoring Component Health and Faults Using Oracle ILOM

The Oracle ILOM 5.0 interfaces provide easy-to-view information about the health status of system components. From the Oracle ILOM web interface or in the Oracle ILOM command-line interface (CLI), you can collect system-specific information about the server, determine the health state of discrete components, and view any open problems on the server. Oracle ILOM automatically detects system hardware faults and environmental conditions on the server. If a problem occurs on the server, Oracle ILOM automatically does the following:

- Illuminate the Fault-Service Required LED status indicator on the server front and back panels. See [Troubleshooting Using the Server Front and Back Panel Status Indicators](#) and [Monitoring System Components](#).
- Identify the faulted component in the Open Problems table. Open problems detected on a host server or system chassis are viewable from either the Open Problems web page or the `/System/Open_problems` CLI target. Refer to *View Open Problems Detected on a Managed Device* in the *Oracle ILOM User's Guide for System Monitoring and Diagnostics Firmware Release 5.0.x* at [Oracle Integrated Lights Out Manager \(ILOM\) 5.0 Documentation](#).
- Record system information about the faulted component or condition in the Oracle ILOM event log. Refer to *Managing ILOM Log Entries* in the *Oracle ILOM User's Guide for System Monitoring and Diagnostics Firmware Release 5.0.x* at [Oracle Integrated Lights Out Manager \(ILOM\) 5.0 Documentation](#).

For further information about administering open problems that are detected and reported by Oracle ILOM, refer to *Administering Open Problems* in the *Oracle ILOM Administrator's Guide for Configuration and Maintenance Firmware Release 5.0.x* at [Oracle Integrated Lights Out Manager \(ILOM\) 5.0 Documentation](#).

## Monitoring System Components

The tables in this section identify the system components and describe the naming conventions applied to the components of Oracle Server X9-2.

Each section corresponds to an IPMI entity ID and lists sensors, indicators, and field-replaceable units (FRUs) related to that entity. The tables contain the following fields:

- **Component Name** – Shows the user-visible component name used in management interfaces to refer to a specific sensor, indicator, or FRU. The IPMI name is a shortened form of the component name, and is indicated by the **boldface** portion of the component name.
- **IPMI Type** – Indicates the type of sensor, indicator, or FRU represented.
- **Description** – Describes the particular component name reference.
- **Values** – Defines the states of the sensor, indicator, or FRU entity, and any specific units or values that are expected, if applicable.

 **Note:**

Some component names are hidden in the Oracle ILOM user interfaces. As of Oracle ILOM 3.2, the Oracle ILOM 3.0 legacy targets `/SYS` and `/STORAGE` were replaced by `/System`. Even though these legacy targets might be hidden, you can still use them to issue commands. For information on legacy targets, see the ILOM 3.2 Documentation Library at [Systems Management and Diagnostics Documentation](#).

This section includes information for the following server components:

- [System Chassis Components](#)
- [Cooling Unit Components](#)
- [Disk Backplane Components](#)
- [Memory Device Components](#)
- [Power Unit Components](#)
- [Processor Components](#)
- [System Motherboard Components](#)
- [System Firmware Components](#)
- [Disk Drive Components](#)

## System Chassis Components

The following table lists the system chassis components.

Component Name (Oracle ILOM CLI Targets)	IPMI Type	Description	Values (if applicable)
<b>/SYS</b>	FRU	Product information only	
<b>/SYS/UUID</b>	FRU	Unique system ID	Derived from host MAC address. Used for PXE boot and licensing.
<b>/SYS/ACPI</b>	State sensor	Advanced Configuration and Power Interface	01h-ACPI_ON_WORKING 20h-ACPI_SOFT_OFF
<b>/SYS/VPS</b>	Threshold sensor	Virtual power sensor	Watts

Component Name (Oracle ILOM CLI Targets)	IPMI Type	Description	Values (if applicable)
/SYS/VPS_CPUS	Threshold sensor	Virtual power sensor (CPUs)	Watts
/SYS/VPS_MEMORY	Threshold sensor	Virtual power sensor (Memory)	Watts
/SYS/VPS_FANS	Threshold sensor	Virtual power sensor (Fans)	Watts
/SYS/T_AMB	Threshold sensor	Ambient temperature on system motherboard	Degrees Celsius
/SYS/TEMP_FAULT	Indicator	Temperature Fault LED	Color: Amber Location: Front panel Off: Normal On: Chassis overtemp fault
/SYS/OK	Indicator	System OK LED	Color: Green Location: Front and back panels Off: Power is off. Standby blink: The host is off, awaiting Power On. Slow blink: Startup sequence initiated on host. On: Host is booting OS or running the OS.
/SYS/SERVICE	Indicator	Fault-Service Required LED	Color: Amber Location: Front and back panels Off: Normal On: Server requires service.
/SYS/LOCATE	Indicator	Locate Button/LED	Color: White Location: Front and back panels Off: Normal Fast blink: Locate function is activated; self- extinguishes after 30 minutes.
/SYS/PS_FAULT	Indicator	Rear Power Supply Fault LED	Color: Amber Location: Front panel Off: Normal On: General power supply fault
/SYS/FAN_FAULT	Indicator	Top Fan Fault LED	Color: Amber Location: Front panel Off: Normal On: General fan fault



Component Name (Oracle ILOM CLI Targets)	IPMI Type	Description	Values (if applicable)
/SYS/DO_NOT_SERVICE	Indicator	Do Not Service LED	Color: White Location: Front panel Off: Normal On: Do not service

## Cooling Unit Components

The system has four 40-mm fan modules with two fans in each module. The following table lists the system cooling unit components.

Component Name (Oracle ILOM CLI Targets)	IPMI Type	Description	Values (if applicable)
/SYS/MB/FM[0-3]	FRU	Fan module FRU	
/SYS/MB/FM[0-3]/F[0-x]	FRU	Individual fan	
/SYS/MB/FM[0-3] /PRSENT	Discrete sensor	Fan module is present.	01h-ENTITY_ABSENT 02h-ENTITY_PRESENT
/SYS/MB/FM[0-3] /F[0-x]/ TACH	Threshold sensor	Fan module fan speed	RPM
/SYS/MB/FM[0-3] / SERVICE	Indicator	Fan Fault-Service Required LED	Color: Amber Location: Motherboard Off: Normal On: Fan module was diagnosed as faulty.

## Disk Backplane Components

The following table lists the disk backplane (DBP) components.

Component Name (Oracle ILOM CLI Targets)	IPMI Type	Description	Values (if applicable)
/SYS/DBP	FRU	Disk backplane FRU	
/SYS/DBP/CPLD	FRU	Disk backplane complex programmable logic device (CPLD)/field programmable gate array (FPGA) firmware FRU	
/SYS/DBP/PRSENT	Discrete sensor	Disk backplane presence (Hidden)	01h-ENTITY_ABSENT 02h-ENTITY_PRESENT
/SYS/DBP/HDD[0- x ]	Pseudo	Hard disk drives (HDD)	
/SYS/DBP/HDD[0- x ]/ PRSENT	Discrete sensor	Hard disk drive presence (Hidden)	01h-ENTITY_ABSENT 02h-ENTITY_PRESENT

Component Name (Oracle ILOM CLI Targets)	IPMI Type	Description	Values (if applicable)
/SYS/DBP/HDD[0- x ]/ STATE	State sensor	Hard disk drive state	01h-FAULT_STATUS 02h-IDENTITY 04h-INSTALLED 20h-SLOT_POWER_OFF
/SYS/DBP/HDD[0- x ]/ SERVICE	Indicator	Fault-Service Required LED	Color: Amber Location: HDD Off: Normal On: HDD was diagnosed as failed
/SYS/DBP/HDD[0- x ]/ OK2RM	Indicator	Hard disk drive OK to remove	Color: Blue Location: HDD Off: Normal On: HDD is OK to remove
/SYS/DBP/HDD[0- x ]/ NVME	FRU	NVMe drive FRU	
/SYS/DBP/HDD[0- x ]/ NVME/PRSNT	Discrete sensor	NVMe device presence	01h-ENTITY_ABSENT 02h-ENTITY_PRESENT
/SYS/VREG_DBP_ERR	Discrete sensor	Disk backplane voltage regulator-down (VRD) error (Hidden)	01h-DEASSERTED 02h-ASSERTED
/SYS/VREG_USB_ERR	Discrete sensor	Universal Serial Bus (USB) VRD error (Hidden)	01h-DEASSERTED 02h-ASSERTED

## Memory Device Components

The following table lists the memory device components.

Component Name (Oracle ILOM CLI Targets)	IPMI Type	Description	Values (if applicable)
/SYS/MB/P[0- x ]/D[0-15]	FRU	Host CPU DIMM FRU	
/SYS/MB/P[0- x ]/D[0-11]/ PRSNT	Discrete sensor	Host CPU DIMM is present.	01h-ENTITY_ABSENT 02h-ENTITY_PRESENT
/SYS/MB/P[0- x ]/D[0-15]/ SERVICE	Indicator	Host CPU DIMM Fault- Service Required LED	Color: Amber Location: Motherboard Off: Normal On: DIMM was diagnosed as faulty.
/SYS/MB/P[0-1]/D[0-11]/ TEMP	Discrete sensor	Host CPU DIMM temperature sensor (Hidden)	

## Power Unit Components

The following table lists the power unit components.

Component Name (Oracle ILOM CLI Targets)	IPMI Type	Description	Values (if applicable)
/SYS/PDB	FRU	Power distribution board FRU	
/SYS/PS[0-1]	FRU	Power supply FRU	
/SYS/PS[0-1]/PRSNT	Discrete sensor	Power supply is present. (Hidden)	01h-ENTITY_ABSENT 02h-ENTITY_PRESENT
/SYS/PS[0-1]/STATE	State sensor	Power supply state sensor Multistate, power supply sensor type, per IPMI	Presence detected Failure detected Predictive failure Power supply input lost Power supply input lost or out-of-range Power supply input out-of- range Configuration error
/SYS/PS[0-1]/P_IN	Threshold sensor	Input power draw	Watts
/SYS/PS[0-1]/P_OUT	Threshold sensor	Output power	Watts
/SYS/PS[0-1]/V_IN	Threshold sensor	Power supply input voltage	Volts
/SYS/PS[0-1]/V_12V	Threshold sensor	Power supply 12V output voltage	Volts
/SYS/PS[0-1]/ V_12V_STBY	Threshold sensor	Power supply 12V standby output voltage	Volts
/SYS/PS[0-1]/T_IN	Threshold sensor	PSU input temperature	Degrees Celsius
/SYS/PS[0-1]/T_OUT	Threshold sensor	PSU output temperature	Degrees Celsius

## Processor Components

The following table lists the processor (CPU) components.

Component Name (Oracle ILOM CLI Targets)	IPMI Type	Description	Values (if applicable)
/SYS/MB/P[0- x]	FRU	Host CPU FRU	
/SYS/MB/P[0- x]/PRSNT	Discrete sensor	Host CPU is present.	01h-ENTITY_PRESENT 02h-ENTITY_ABSENT
/SYS/MB/P[0- x]/ SERVICE	Indicator	Host CPU Fault-Service Required LED	Color: Amber Location: Motherboard Off: Normal On: Processor was diagnosed as faulty.

## System Motherboard Components

The following table lists the system motherboard components.

Component Name (Oracle ILOM CLI Targets)	IPMI Type	Description	Values (if applicable)
/SYS/MB	FRU	General host system motherboard FRU	
/SYS/MB/NET[0- x]	FRU	Host Ethernet FRU	
/SYS/MB/PCIE5	FRU	Internal PCIe slot on for OCP NIC card	
/SYS/MB/PCIE5/POWER	Indicator	PCIe slot power LED (internal slot for OCP NIC card)	Color: Green Location: Motherboard On: Internal PCIe slot power is on. Off: Internal PCIe slot power is off.
/SYS/MB/PCIE5/SERVICE	Indicator	PCIe slot service LED (internal slot for OCP NIC card)	Color: Amber Location: Motherboard On: Service required Off: Normal
/SYS/MB/RISER[1-3]	FRU	PCIe riser card FRU	
/SYS/MB/RISER[1-3 ]/ PCIE[ x ]	FRU	PCIe slot on riser FRU	
/SYS/MB/RISER[1-3]/ PCIE[ x ]/ POWER	Indicator	PCIe slot power LED	Color: Green Location: Motherboard On: Slot power is on Off: Slot power is off
/SYS/MB/RISER[1-3 ]/ PCIE[ x ]/PRSENT	Discrete sensor	PCIe slot on riser 1-3 is present.	01h-ENTITY_ABSENT 02h-ENTITY_PRESENT
/SYS/MB/RISER[1-3]/ PCIE[ x ]/SERVICE	Indicator	PCIe slot service LED	Color: Amber Location: Motherboard On: Service Required Off: Normal
/SYS/MB/RISER[1-3]/ PRSENT	Discrete sensor	PCIe slot riser is present	01h-ENTITY_ABSENT 02h-ENTITY_PRESENT
/SYS/MB/ROT	FRU	Root of trust FRU	
/SYS/MB/T_IN_ZONE[01, 1, 23]	Threshold sensor	Cooling zone chassis inlet temperature, located in front of the specified PCIe slots <ul style="list-style-type: none"> <li>• Slot 01 – PCIe slot 01</li> <li>• Slot 1 – PCIe slot 1</li> <li>• Slot 23 – PCIe slot 23</li> </ul>	Degrees Celsius

Component Name (Oracle ILOM CLI Targets)	IPMI Type	Description	Values (if applicable)
/SYS/MB/T_OUT_ZONE[2]	Threshold sensor	Cooling zone chassis exhaust temperature, located behind the PCIe slot 2	Degrees Celsius
/SYS/SP	FRU	Service processor FRU	
/SYS/SP/OK	Indicator	SP OK LED	Color: Green Location: Front panel On: SP is operating. Off: SP requires service.
/SYS/SP/NET[0-1]	FRU	SP Ethernet FRU	

## System Firmware Components

The following table lists the system firmware components.

Component Name (Oracle ILOM CLI Target)	IPMI Type	Description
/SYS/MB/BIOS	FRU	BIOS FRU
/SYS/MB/CPLD	FRU	Motherboard complex programmable logic device (CPLD)/field programmable gate array (FPGA) firmware version

## Disk Drive Components

The following table lists the hard disk drive (HDD) and solid state drive (SSD) components.

Component Name (Oracle ILOM CLI Targets)	IPMI Type	Description	Values (if applicable)
/SYS/DBP/HDD[0- x ]	FRU	Hard disk drive FRU	From host
/SYS/DBP/HDD[0- x ]/PRSNT	Discrete sensor	Hard disk drive presence	01h-ENTITY_ABSENT 02h-ENTITY_PRESENT
/SYS/DBP/HDD[0- x ]/STATE	Discrete sensor	Writable multistate, slot/connector sensor type, per IPMI	01h-FAULT_STATUS 02h-IDENTITY 04h-INSTALLED 20h-SLOT_POWER_OFF
/SYS/DBP/HDD[0- x ]/SERVICE	Indicator	Hard disk drive Fault-Service Required LED	Color: Amber Location: HDD Off: Normal On: Hard disk drive was diagnosed as faulty.

Component Name (Oracle ILOM CLI Targets)	IPMI Type	Description	Values (if applicable)
/SYS/DBP/HDD[0- x ]/ OK2RM	Indicator	Hard disk drive OK to Remove LED	Color: Blue Location: HDD Off: Normal On: Drive is ready to remove.
/SYS/DBP/HDD[0- x ]/ NVME	FRU	NVMe drive FRU	
/SYS/DBP/HDD[0- x ]/ NVME/PRSNT	Discrete sensor	NVMe device presence	01h-ENTITY_ABSENT 02h-ENTITY_PRESENT
/SYS/MB/SSDR[0-1]	FRU	Internal SSD riser (1 on 1U, 2 on 2U) FRU	
/SYS/MB/SSDR[0-1]/ PRSNT	Discrete sensor	Solid-state drive (SSD) riser presence (1 riser on 1U)	01h-ENTITY_ABSENT 02h-ENTITY_PRESENT
/SYS/MB/SSDR[0-1]/ SSD[0-1]	FRU	Internal SSD drive FRU	
/SYS/MB/SSDR[0-1]/ SSD[0-1]/PRSNT	Discrete sensor	SSD drive presence (2 SSDs per riser) ( <i>Hidden</i> )	01h-ENTITY_ABSENT 02h-ENTITY_PRESENT
/SYS/MB/SSDR[0-1]/ SSD[0-1]/STATE	State sensor	SSD drive state	04h-INSTALLED 20h-SLOT POWER OFF
/SYS/MB/SSDR[0-1]/ SSD[0-1]/NVME	FRU	Internal SSD that is NVM Express FRU	
/SYS/MB/SSDR[0-1]/ SSD[0-1]/NVME/PRSNT	Discrete sensor	Indicates the SSD is PCIe (NVMeExpress)	01h-ENTITY_ABSENT 02h-ENTITY_PRESENT

## Identifying SNMP Trap Messages

You can configure Oracle ILOM to generate Simple Network Management Protocol (SNMP) traps when hardware problems occur. For information about how to configure SNMP alert rule destinations to start receiving these traps, refer to the [Oracle Integrated Lights Out Manager \(ILOM\) 5.0 Documentation](#).

The tables in these sections list the set of SNMP traps that are generated from Oracle ILOM.

- [Environmental Events](#)
- [Hard Disk Drive Events](#)
- [Power Events](#)
- [Fan Events](#)
- [Memory Events](#)
- [Entity Presence Events](#)

## Environmental Events

The following table lists environmental events.

Messages and Descriptions	Component Name
<p><b>SNMP Trap:</b> sunHwTrapTempFatalThresholdExceeded</p> <p><b>Oracle ILOM Event Message:</b> Lower fatal threshold exceeded</p> <p><b>Severity and Description:</b> Critical; A temperature sensor has reported that its value has gone above an upper fatal threshold setting or below a lower fatal threshold setting.</p> <p>The sunHwTrapThresholdType object indicates whether the threshold was an upper or lower threshold.</p>	<p>/SYS/PS[0-1]/T_OUT</p> <p>/SYS/PS[0-1]/T_IN</p> <p>/SYS/MB/T_IN_SLOT[1-3]</p> <p>/SYS/MB/T_OUT_SLOT[1-3]</p>
<p><b>SNMP Trap:</b> sunHwTrapTempFatalThresholdDeasserted</p> <p><b>Oracle ILOM Event Message:</b> Lower fatal threshold no longer exceeded</p> <p><b>Severity and Description:</b> Informational; A temperature sensor has reported that its value has gone below an upper fatal threshold setting or above a lower fatal threshold setting.</p> <p>The sunHwTrapThresholdType object indicates whether the threshold was an upper or lower threshold.</p>	<p>/SYS/PS[0-1]/T_OUT</p> <p>/SYS/PS[0-1]/T_IN</p> <p>/SYS/MB/T_IN_SLOT[1-3]</p> <p>/SYS/MB/T_OUT_SLOT[1-3]</p>
<p><b>SNMP Trap:</b> sunHwTrapTempCritThresholdExceeded</p> <p><b>Oracle ILOM Event Message:</b> Upper critical threshold exceeded</p> <p><b>Severity and Description:</b> Critical; A temperature sensor has reported that its value has gone above an upper critical threshold setting or below a lower critical threshold setting.</p> <p>The sunHwTrapThresholdType object indicates whether the threshold was an upper or lower threshold.</p>	<p>/SYS/PS[0-1]/T_OUT</p> <p>/SYS/PS[0-1]/T_IN</p> <p>/SYS/MB/T_IN_SLOT[1-3]</p> <p>/SYS/MB/T_OUT_SLOT[1-3]</p>
<p><b>SNMP Trap:</b> sunHwTrapTempCritThresholdDeasserted</p> <p><b>Oracle ILOM Event Message:</b> Upper critical threshold no longer exceeded</p> <p><b>Severity and Description:</b> Informational; A temperature sensor has reported that its value has gone below an upper critical threshold setting or above a lower critical threshold setting.</p> <p>The sunHwTrapThresholdType object indicates whether the threshold was an upper or lower threshold.</p>	<p>/SYS/PS[0-1]/T_OUT</p> <p>/SYS/PS[0-1]/T_IN</p> <p>/SYS/MB/T_IN_SLOT[1-3]</p> <p>/SYS/MB/T_OUT_SLOT[1-3]</p>
<p><b>SNMP Trap:</b> sunHwTrapTempFatalThresholdExceeded</p> <p><b>Oracle ILOM Event Message:</b> Lower fatal threshold exceeded</p> <p><b>Severity and Description:</b> Critical; A temperature sensor has reported that its value has gone above an upper fatal threshold setting or below a lower fatal threshold setting.</p> <p>The sunHwTrapThresholdType object indicates whether the threshold was an upper or lower threshold.</p>	<p>/SYS/T_AMB</p>

Messages and Descriptions	Component Name
<p><b>SNMP Trap:</b> sunHwTrapTempFatalThresholdDeasserted</p> <p><b>Oracle ILOM Event Message:</b> Lower fatal threshold no longer exceeded</p> <p><b>Severity and Description:</b> Informational; A temperature sensor has reported that its value has gone below an upper fatal threshold setting or above a lower fatal threshold setting.</p> <p>The sunHwTrapThresholdType object indicates whether the threshold was an upper or lower threshold.</p>	/SYS/T_AMB

## Hard Disk Drive Events

The following table lists hard disk drive events.

Messages and Descriptions	Component Name
<p><b>SNMP Trap:</b> sunHwTrapSlotOrConnectorError</p> <p><b>Oracle ILOM Event Message:</b> Assert</p> <p><b>Severity and Description:</b> Major; A sensor associated with a slot or connector has detected an error.</p>	/SYS/DBP/HDD[0-x]/STATE
<p><b>SNMP Trap:</b> sunHwTrapSlotOrConnectorOk</p> <p><b>Oracle ILOM Event Message:</b> Deassert</p> <p><b>Severity and Description:</b> Informational; A sensor associated with a slot or connector has returned to its normal state.</p>	/SYS/DBP/HDD[0-x]/STATE

## Power Events

The following table lists power events.

Messages and Descriptions	Component Name
<p><b>SNMP Trap:</b> sunHwTrapPowerSupplyError</p> <p><b>Oracle ILOM Event Message:</b> PS_PRESENCE ASSERT</p> <p><b>Severity and Description:</b> Major; A power supply sensor has detected an error.</p>	/SYS/PS[0-1]/STATE
<p><b>SNMP Trap:</b> sunHwTrapPowerSupplyOk</p> <p><b>Oracle ILOM Event Message:</b> PS_PRESENCE DEASSERT</p> <p><b>Severity and Description:</b> Major; A power supply sensor has detected an error.</p>	/SYS/PS[0-1]/STATE
<p><b>SNMP Trap:</b> sunHwTrapPowerSupplyError</p> <p><b>Oracle ILOM Event Message:</b> PS_FAILURE ASSERT</p> <p><b>Severity and Description:</b> Major; A power supply sensor has detected an error.</p>	/SYS/PS[0-1]/STATE



Messages and Descriptions	Component Name
<b>SNMP Trap:</b> sunHwTrapPowerSupplyOk <b>Oracle ILOM Event Message:</b> PS_FAILURE DEASSERT <b>Severity and Description:</b> Major; A power supply sensor has detected an error.	/SYS/PS[0-1]/STATE
<b>SNMP Trap:</b> sunHwTrapPowerSupplyError <b>Oracle ILOM Event Message:</b> PS_PREDICTIVE_FAILURE ASSERT <b>Severity and Description:</b> Major; A power supply sensor has detected an error.	/SYS/PS[0-1]/STATE
<b>SNMP Trap:</b> sunHwTrapPowerSupplyOk <b>Oracle ILOM Event Message:</b> PS_PREDICTIVE_FAILURE DEASSERT <b>Severity and Description:</b> Major; A power supply sensor has detected an error.	/SYS/PS[0-1]/STATE
<b>SNMP Trap:</b> sunHwTrapPowerSupplyError <b>Oracle ILOM Event Message:</b> PS_INPUT_LOST ASSERT <b>Severity and Description:</b> Major; A power supply sensor has detected an error.	/SYS/PS[0-1]/STATE
<b>SNMP Trap:</b> sunHwTrapPowerSupplyOk <b>Oracle ILOM Event Message:</b> PS_INPUT_LOST DEASSERT <b>Severity and Description:</b> Major; A power supply sensor has detected an error.	/SYS/PS[0-1]/STATE
<b>SNMP Trap:</b> sunHwTrapPowerSupplyError <b>Oracle ILOM Event Message:</b> PS_INPUT_ERROR ASSERT <b>Severity and Description:</b> Major; A power supply sensor has detected an error.	/SYS/PS[0-1]/STATE
<b>SNMP Trap:</b> sunHwTrapPowerSupplyOk <b>Oracle ILOM Event Message:</b> PS_INPUT_ERROR DEASSERT <b>Severity and Description:</b> Major; A power supply sensor has detected an error.	/SYS/PS[0-1]/STATE
<b>SNMP Trap:</b> sunHwTrapPowerSupplyError <b>Oracle ILOM Event Message:</b> PS_INPUT_RANGE_ERROR ASSERT <b>Severity and Description:</b> Major; A power supply sensor has detected an error.	/SYS/PS[0-1]/STATE
<b>SNMP Trap:</b> sunHwTrapPowerSupplyOk <b>Oracle ILOM Event Message:</b> PS_INPUT_RANGE_ERROR DEASSERT <b>Severity and Description:</b> Major; A power supply sensor has detected an error.	/SYS/PS[0-1]/STATE

Messages and Descriptions	Component Name
<p><b>SNMP Trap:</b> sunHwTrapPowerSupplyError</p> <p><b>Oracle ILOM Event Message:</b> PS_CONFIG_ERROR ASSERT</p> <p><b>Severity and Description:</b> Major; A power supply sensor has detected an error.</p>	/SYS/PS[0-1]/STATE
<p><b>SNMP Trap:</b> sunHwTrapPowerSupplyOk</p> <p><b>Oracle ILOM Event Message:</b> PS_CONFIG_ERROR DEASSERT</p> <p><b>Severity and Description:</b> Major; A power supply sensor has detected an error.</p>	/SYS/PS[0-1]/STATE
<p><b>SNMP Trap:</b> sunHwTrapSensorNonCritThresholdExceeded</p> <p><b>Oracle ILOM Event Message:</b> Upper noncritical threshold exceeded</p> <p><b>Severity and Description:</b> Minor; A sensor has reported that its value has gone above an upper non critical threshold setting or below a lower non critical threshold setting. This generic 'sensor' trap is generated when the SNMP agent does not recognize the component type.</p> <p>The sunHwTrapThresholdType object indicates whether the threshold was an upper or lower threshold.</p>	/SYS/VPS
<p><b>SNMP Trap:</b> sunHwTrapSensorThresholdOk</p> <p><b>Oracle ILOM Event Message:</b> Upper noncritical threshold no longer exceeded</p> <p><b>Severity and Description:</b> Informational; A sensor has reported that its value is in the normal operating range. This generic 'sensor' trap is generated when the SNMP agent does not recognize the component type.</p>	/SYS/VPS
<p><b>SNMP Trap:</b> sunHwTrapSensorNonCritThresholdExceeded</p> <p><b>Oracle ILOM Event Message:</b> Upper noncritical threshold exceeded</p> <p><b>Severity and Description:</b> Minor; A sensor has reported that its value has gone above an upper noncritical threshold setting or below a lower noncritical threshold setting. This generic 'sensor' trap is generated when the SNMP agent does not recognize the component type.</p> <p>The sunHwTrapThresholdType object indicates whether the threshold was an upper or lower threshold.</p>	/SYS/VPS_FANS /SYS/PS[0-1]/P_IN /SYS/PS[0-1]/P_OUT
<p><b>SNMP Trap:</b> sunHwTrapSensorThresholdOk</p> <p><b>Oracle ILOM Event Message:</b> Upper noncritical threshold no longer exceeded</p> <p><b>Severity and Description:</b> Informational; A sensor has reported that its value is in the normal operating range. This generic 'sensor' trap is generated when the SNMP agent does not recognize the component type.</p>	/SYS/VPS_FANS /SYS/PS[0-1]/P_IN /SYS/PS[0-1]/P_OUT

Messages and Descriptions	Component Name
<p><b>SNMP Trap:</b> sunHwTrapSensorFatalThresholdExceeded</p> <p><b>Oracle ILOM Event Message:</b> Lower fatal threshold exceeded</p> <p><b>Severity and Description:</b> Critical; A power supply sensor has reported that its value has gone above an upper fatal threshold setting or below a lower fatal threshold setting.</p> <p>The sunHwTrapThresholdType object indicates whether the threshold was an upper or lower threshold.</p>	<p>/SYS/PS[0-1]/P_IN /SYS/PS[0-1]/P_OUT</p>
<p><b>SNMP Trap:</b> sunHwTrapSensorFatalThresholdDeasserted</p> <p><b>Oracle ILOM Event Message:</b> Lower fatal threshold no longer exceeded</p> <p><b>Severity and Description:</b> Informational; A power supply sensor has reported that its value has gone below an upper fatal threshold setting or above a lower fatal threshold setting.</p> <p>The sunHwTrapThresholdType object indicates whether the threshold was an upper or lower threshold.</p>	<p>/SYS/PS[0-1]/P_IN /SYS/PS[0-1]/P_OUT</p>
<p><b>SNMP Trap:</b> sunHwTrapSensorCritThresholdExceeded</p> <p><b>Oracle ILOM Event Message:</b> Lower critical threshold exceeded</p> <p><b>Severity and Description:</b> Major; A power supply sensor has reported that its value has gone above an upper critical threshold setting or below a lower critical threshold setting.</p> <p>The sunHwTrapThresholdType object indicates whether the threshold was an upper or lower threshold.</p>	<p>/SYS/PS[0-1]/P_IN /SYS/PS[0-1]/P_OUT</p>
<p><b>SNMP Trap:</b> sunHwTrapSensorCritThresholdDeasserted</p> <p><b>Oracle ILOM Event Message:</b> Lower critical threshold no longer exceeded</p> <p><b>Severity and Description:</b> Informational; A power supply sensor has reported that its value has gone below an upper critical threshold setting or above a lower critical threshold setting.</p> <p>The sunHwTrapThresholdType object indicates whether the threshold was an upper or lower threshold.</p>	<p>/SYS/PS[0-1]/P_IN /SYS/PS[0-1]/P_OUT</p>
<p><b>SNMP Trap:</b> sunHwTrapVoltageFatalThresholdExceeded</p> <p><b>Oracle ILOM Event Message:</b> Lower fatal threshold exceeded</p> <p><b>Severity and Description:</b> Critical; A voltage sensor has reported that its value has gone above an upper fatal threshold setting or below a lower fatal threshold setting.</p> <p>The sunHwTrapThresholdType object indicates whether the threshold was an upper or lower threshold.</p>	<p>/SYS/PS[0-1]/V_12V /SYS/PS[0-1]/V_12V_STBY /SYS/PS[0-1]/V_IN</p>

Messages and Descriptions	Component Name
<p><b>SNMP Trap:</b> sunHwTrapVoltageFatalThresholdDeasserted</p> <p><b>Oracle ILOM Event Message:</b> Lower fatal threshold no longer exceeded</p> <p><b>Severity and Description:</b> Informational; A voltage sensor has reported that its value has gone below an upper fatal threshold setting or above a lower fatal threshold setting.</p> <p>The sunHwTrapThresholdType object indicates whether the threshold was an upper or lower threshold.</p>	<p>/SYS/PS[0-1]/V_12V</p> <p>/SYS/PS[0-1]/V_12V_STBY</p> <p>/SYS/PS[0-1]/V_IN</p>
<p><b>SNMP Trap:</b> sunHwTrapVoltageCritThresholdExceeded</p> <p><b>Oracle ILOM Event Message:</b> Upper critical threshold exceeded</p> <p><b>Severity and Description:</b> Critical; A voltage sensor has reported that its value has gone above an upper critical threshold setting or below a lower critical threshold setting.</p> <p>The sunHwTrapThresholdType object indicates whether the threshold was an upper or lower threshold.</p>	<p>/SYS/PS[0-1]/V_12V</p> <p>/SYS/PS[0-1]/V_12V_STBY</p> <p>/SYS/PS[0-1]/V_IN</p>
<p><b>SNMP Trap:</b> sunHwTrapVoltageCritThresholdDeasserted</p> <p><b>Oracle ILOM Event Message:</b> Upper critical threshold no longer exceeded</p> <p><b>Severity and Description:</b> Informational; A voltage sensor has reported that its value has gone below an upper critical threshold setting or above a lower critical threshold setting.</p> <p>The sunHwTrapThresholdType object indicates whether the threshold was an upper or lower threshold.</p>	<p>/SYS/PS[0-1]/V_12V</p> <p>/SYS/PS[0-1]/V_12V_STBY</p> <p>/SYS/PS[0-1]/V_IN</p>
<p><b>SNMP Trap:</b> sunHwTrapVoltageNonCritThresholdExceeded</p> <p><b>Oracle ILOM Event Message:</b> Upper noncritical threshold exceeded</p> <p><b>Severity and Description:</b> Minor; A voltage sensor has reported that its value has gone above an upper noncritical threshold setting or below a lower noncritical threshold setting.</p> <p>The sunHwTrapThresholdType object indicates whether the threshold was an upper or lower threshold.</p>	<p>/SYS/PS[0-1]/V_12V</p> <p>/SYS/PS[0-1]/V_12V_STBY</p> <p>/SYS/PS[0-1]/V_IN</p>
<p><b>SNMP Trap:</b> sunHwTrapVoltageOk</p> <p><b>Oracle ILOM Event Message:</b> Upper noncritical threshold no longer exceeded</p> <p><b>Severity and Description:</b> Informational; A voltage sensor has reported that its value is in the normal operating range.</p>	<p>/SYS/PS[0-1]/V_12V</p> <p>/SYS/PS[0-1]/V_12V_STBY</p> <p>/SYS/PS[0-1]/V_IN</p>

Messages and Descriptions	Component Name
<p><b>SNMP Trap:</b> sunHwTrapSensorNonCritThresholdExceeded</p> <p><b>Oracle ILOM Event Message:</b> Upper noncritical threshold exceeded</p> <p><b>Severity and Description:</b> Minor; A sensor has reported that its value has gone above an upper noncritical threshold setting or below a lower noncritical threshold setting. This generic 'sensor' trap is generated when the SNMP agent does not recognize the component type.</p> <p>The sunHwTrapThresholdType object indicates whether the threshold was an upper or lower threshold.</p>	<p>/SYS/VPS_CPUS /SYS/VPS_MEMORY</p>
<p><b>SNMP Trap:</b> sunHwTrapSensorThresholdOk</p> <p><b>Oracle ILOM Event Message:</b> Upper noncritical threshold no longer exceeded</p> <p><b>Severity and Description:</b> Informational; A sensor has reported that its value is in the normal operating range. This generic 'sensor' trap is generated when the SNMP agent does not recognize the component type.</p>	<p>/SYS/VPS_CPUS /SYS/VPS_MEMORY</p>

## Fan Events

The following table lists fan events.

Messages and Descriptions	Component Name
<p><b>SNMP Trap:</b> sunHwTrapFanSpeedCritThresholdExceeded</p> <p><b>Oracle ILOM Event Message:</b> Lower critical threshold exceeded</p> <p><b>Severity and Description:</b> Major; A fan speed sensor has reported that its value has gone above an upper critical threshold setting or below a lower critical threshold setting.</p> <p>The sunHwTrapThresholdType object indicates whether the threshold was an upper or lower threshold.</p>	<p>/SYS/MB/FM[0-3]/F[0-x]/TACH</p>
<p><b>SNMP Trap:</b> sunHwTrapFanSpeedCritThresholdDeasserted</p> <p><b>Oracle ILOM Event Message:</b> Lower critical threshold no longer exceeded</p> <p><b>Severity and Description:</b> Informational; A fan speed sensor has reported that its value has gone below an upper critical threshold setting or above a lower critical threshold setting.</p> <p>The sunHwTrapThresholdType object indicates whether the threshold was an upper or lower threshold.</p>	<p>/SYS/MB/FM[0-3]/F[0-x]/TACH</p>

Messages and Descriptions	Component Name
<p><b>SNMP Trap:</b> sunHwTrapFanSpeedFatalThresholdExceeded</p> <p><b>Oracle ILOM Event Message:</b> Lower fatal threshold exceeded</p> <p><b>Severity and Description:</b> Critical; A fan speed sensor has reported that its value has gone above an upper fatal threshold setting or below a lower fatal threshold setting.</p> <p>The sunHwTrapThresholdType object indicates whether the threshold was an upper or lower threshold.</p>	/SYS/MB/FM[0-3]/F[0-x]/TACH
<p><b>SNMP Trap:</b> sunHwTrapFanSpeedFatalThresholdDeasserted</p> <p><b>Oracle ILOM Event Message:</b> Lower fatal threshold no longer exceeded</p> <p><b>Severity and Description:</b> Informational; A fan speed sensor has reported that its value has gone below an upper fatal threshold setting or above a lower fatal threshold setting.</p> <p>The sunHwTrapThresholdType object indicates whether the threshold was an upper or lower threshold.</p>	/SYS/MB/FM[0-3]/F[0-x]/TACH

## Memory Events

The following table lists memory events.

Messages and Descriptions	Component Name
<p><b>SNMP Trap:</b> sunHwTrapMemoryFault</p> <p><b>Oracle ILOM Event Message:</b> event fault.cpu.intel.quickpath.link_slow "The Quickpath Interconnect (QPI) link is operating below normal speed."</p> <p><b>Severity and Description:</b> Major; A memory component is suspected of causing a fault.</p>	/SYS/MB
<p><b>SNMP Trap:</b> sunHwTrapMemoryFaultCleared</p> <p><b>Oracle ILOM Event Message:</b> event fault.cpu.intel.quickpath.link_slow "The Quickpath Interconnect (QPI) link is operating below normal speed."</p> <p><b>Severity and Description:</b> Informational; A memory component fault has been cleared.</p>	/SYS/MB
<p><b>SNMP Trap:</b> sunHwTrapMemoryFault</p> <p><b>Oracle ILOM Event Message:</b> event fault.cpu.intel.quickpath.unknown-errcode "An unknown error code from the Quickpath Interconnect (QPI) reference code has been detected."</p> <p><b>Severity and Description:</b> Major; A memory component is suspected of causing a fault.</p>	/SYS/MB

Messages and Descriptions	Component Name
<b>SNMP Trap:</b> sunHwTrapMemoryFaultCleared <b>Oracle ILOM Event Message:</b> event fault.cpu.intel.quickpath.unknown-errcode "An unknown error code from the Quickpath Interconnect (QPI) reference code has been detected." <b>Severity and Description:</b> Informational; A memory component fault has been cleared.	/SYS/MB

## Entity Presence Events

The following table lists entity presence events.

Messages and Descriptions	Component Name
<b>SNMP Trap:</b> sunHwTrapProcessorError <b>Oracle ILOM Event Message:</b> ENTITY_PRESENT ASSERT <b>Severity and Description:</b> Major; A processor sensor has detected an error. Device absent.	/SYS/MB/P[0-x]/PRSNT
<b>SNMP Trap:</b> sunHwTrapProcessorOk <b>Oracle ILOM Event Message:</b> ENTITY_PRESENT DEASSERT <b>Severity and Description:</b> Major; A processor sensor has returned to its normal state. Device present.	/SYS/MB/P[0-x]/PRSNT
<b>SNMP Trap:</b> sunHwTrapProcessorError <b>Oracle ILOM Event Message:</b> ENTITY_DISABLED ASSERT <b>Severity and Description:</b> Major; A processor sensor has detected an error. Device disabled.	/SYS/MB/P[0-x]/PRSNT
<b>SNMP Trap:</b> sunHwTrapProcessorOk <b>Oracle ILOM Event Message:</b> ENTITY_DISABLED DEASSERT <b>Severity and Description:</b> Major; A processor sensor has returned to its normal state. Device enabled.	/SYS/MB/P[0-x]/PRSNT

# Index

## A

---

- A271 1400W power supplies, [6-1](#)
- activity indicator, [2-5](#)
- add-in cards
  - configuration utilities in UEFI BIOS, [22-4](#)
- Advanced BIOS screen, [23-2](#)
- antistatic
  - using wrist strap and mat, [3-2](#)
- attaching devices to server, [2-16](#)
- Auto Service Request, [2-23](#)

## B

---

- battery
  - description, [1-6](#)
  - installing, [11-2](#)
  - removing, [11-1](#)
- BIOS factory defaults, verifying, [22-6](#)
- BIOS Setup Utility
  - accessing, [22-2](#)
  - Advanced screen, [23-2](#)
  - Boot screen, [23-13](#)
  - Exit screen, [23-13](#)
  - exiting from, [22-10](#)
  - function keys, [22-2](#)
  - IO screen, [23-11](#)
  - Main screen, [23-1](#)
  - menus, accessing, [22-2](#)
  - navigating menu options, [22-3](#)
  - Security screen, [23-12](#)
  - setup screens summary, [22-1](#)
  - shortcut key sequences, [22-2](#)
  - TPM support, [22-7](#)
  - UEFI BIOS, [22-4](#)
- board components, [24-2](#)
- boot device, selecting, [22-6](#)
- boot drive
  - LEDs, [2-7](#)
- boot process
  - power modes, [2-4](#)
- buttons
  - On/Standby, [3-7](#)

## C

---

- cable part number
  - NVMe cables, [16-3](#)
- cables
  - data and power
    - connecting, [20-5](#)
- cabling the server, [2-16](#)
- chassis components, [24-2](#)
- chassis serial number, locating, [2-22](#)
- components and nomenclature, [24-2](#)
- connecting devices to server, [2-16](#)
- connector locations, [2-16](#)
- cooling
  - troubleshooting issues, [2-10](#)
- cooling unit components, [24-4](#)

## D

---

- diagnostics
  - available tools, [2-14](#)
  - documentation, [2-15](#)
- DIMM channel population order, [7-5](#)
- DIMMs
  - description, [1-6](#)
  - fault LEDs
    - inconsistencies with BIOS, [7-8](#)
  - Fault Remind button, [7-9](#)
  - identifying a failed DIMM, [7-9](#)
  - installing, [7-11](#)
  - labels, [7-8](#)
  - physical layout, [7-2](#)
  - population for optimal performance, [7-4](#)
  - population rules, [7-3](#)
  - rank classification labels, [7-8](#)
  - removing, [7-9](#)
  - replacing, [7-1](#)
  - speed, [7-8](#)
  - supported configurations, [7-3](#)
- disk backplane
  - components, [24-4](#)
  - description, [1-6](#)
  - installing, [13-3](#)
  - removing, [13-1](#)
  - replacing, [13-1](#)



disk backplane cables  
 installing, [17-4](#)  
 removing, [17-1](#)  
 servicing, [17-1](#)  
 disk components, [24-8](#)  
 disk drives, [4-1](#)

## E

---

electrostatic discharge  
 prevention, [3-12](#)  
 safety precautions, [3-2](#)  
 See ESD, [3-12](#)  
 entity presence events, [24-18](#)  
 environmental events, [24-10](#)  
 Ethernet cables, connecting, [2-16](#)  
 Ethernet ports  
 device and driver naming, [2-20](#)  
 pinouts, [21-1](#)  
 status indicators, [2-9](#)  
 Exit BIOS screen, [23-13](#)  
 exploded view of server, [1-4](#)  
 external cables, connecting, [2-16](#)

## F

---

fan events, [24-16](#)  
 fan module  
 status indicators, [2-7](#)  
 fan modules  
 description, [1-6](#)  
 installing, [5-3](#)  
 removing, [5-1](#)  
 fault identification  
 DIMMs, [7-9](#)  
 storage drives, [2-7](#)  
 Fault Remind button  
 location, [7-9](#)  
 using, [7-9](#)  
 Fault-Service Required LED, [2-5](#)  
 FIM  
 installing, [14-3](#)  
 removing, [14-1](#)  
 servicing, [14-1](#)  
 FIM cable  
 installing, [17-4](#)  
 removing, [17-1](#)  
 servicing, [17-1](#)  
 firmware components, [24-2](#)  
 Front Indicator Module, [14-1](#)  
 front panel indicators, [1-2](#)  
 FRU key identity properties (KIP), [3-3](#)  
 function keys within BIOS Setup Utility, [22-2](#)

## G

---

Gigabit Ethernet ports  
 pinouts, [21-1](#)

## H

---

hard disk drive components, [24-8](#)  
 hard disk drive events, [24-11](#)  
 hard drives, [4-1](#)  
 hardware faults  
 diagnosing, [2-4](#)  
 HBA super capacitor  
 replacing, [18-1](#)  
 hot-plugging storage drives, [4-1](#)

## I

---

identifying Simple Network Management Protocol (SNMP) Trap messages, [24-9](#)  
 illustrated parts breakdown, [1-4](#)  
 installing components  
 battery, [11-2](#)  
 DIMMs, [7-11](#)  
 disk backplane cables, [17-4](#)  
 fan modules, [5-3](#)  
 FIM, [14-3](#)  
 FIM cable, [17-4](#)  
 M.2 flash SSD, [10-5](#)  
 M.2 mezzanine, [10-3](#)  
 NVMe cables, [16-3](#)  
 OCP NIC, [18-3](#)  
 PCIe risers, [8-3](#)  
 power cable, [17-4](#)  
 power supply, [6-4](#)  
 processors, [12-8](#)  
 server into rack, [20-3](#)  
 storage drives, [4-4](#), [4-7](#), [4-10](#)  
 temperature sensor, [15-4](#)  
 temperature sensor cable, [17-4](#)  
 internal HBA card  
 replacing, [18-1](#)  
 internal M.2 flash SSDs  
 description, [1-6](#)  
 IO allocation  
 enabling and disabling resources, [22-8](#)  
 IO BIOS screen, [23-11](#)  
 IPMI type, [24-1](#)

## L

---

latch release button  
 storage drive, [4-6](#), [4-9](#)

LED indicator module  
description, [1-6](#)

LEDs  
boot drive, [2-7](#)  
power supply, [2-8](#), [6-2](#)  
storage drive, [2-7](#)  
system status, [2-5](#)

Locate Button/LED, [2-5](#)

locating chassis serial number, [2-22](#)

## M

---

M.2 flash SSD  
installing, [10-5](#)  
removing, [10-4](#)

M.2 mezzanine  
installing, [10-3](#)  
removing, [10-1](#)

Main BIOS screen, [23-1](#)

memory, [7-1](#)

memory device components, [24-5](#)

memory events, [24-17](#)

menus, BIOS Setup Utility, [22-2](#)

motherboard assembly  
description, [1-6](#)  
removing, [19-2](#)  
servicing, [19-1](#)

## N

---

NET MGT port  
pinout, [2-8](#), [21-1](#)

NVMe cables  
description, [1-6](#)  
installing, [16-3](#)  
removing, [16-1](#)

NVMe storage drives  
removing and replacing using Oracle Linux,  
[4-8](#)  
removing and replacing using Oracle Solaris,  
[4-5](#)

## O

---

OCP NIC  
installing, [18-3](#)  
removing, [18-1](#)

OCP V3 NIC  
description, [1-6](#)

OK to Remove indicator  
storage drives, [2-7](#)

open problems, [24-1](#)

Oracle Integrated Lights Out Manager (ILOM)  
key identity properties (KIP) for FRUID auto-  
update feature, [3-3](#)

## P

---

PCIe cards  
description, [1-6](#)  
installing, [9-3](#)  
removing, [9-2](#)  
servicing, [9-1](#)  
slot characteristics, [9-1](#)

PCIe risers  
description, [1-6](#)  
installing, [8-3](#)  
location and differences, [8-1](#)  
removing, [8-2](#)

PCIe slot numbering, [9-1](#)

pinout  
USB port, [21-3](#)

pinouts  
Ethernet ports, [21-1](#)  
Gigabit Ethernet ports, [21-1](#)  
RJ-45 to DB-9 crossover wiring, [21-2](#)  
serial management (SER MGT), [21-2](#)

population rules  
DIMMs, [7-3](#)

ports  
Ethernet, [21-1](#)  
Gigabit Ethernet, [21-1](#)  
NET MGT, [21-1](#)  
network management (NET MGT), [2-8](#)  
serial management, [21-2](#)  
serial management (SER MGT), [21-2](#)  
USB, [21-3](#)

power  
standby mode, [3-7](#), [3-9](#)  
standby power mode, [3-10](#)  
troubleshooting issues, [2-12](#)

power cable  
installing, [17-4](#)  
removing, [17-1](#)  
servicing, [17-1](#)

power down server  
gracefully, [3-5](#)  
with On/Standby button, [3-7](#)

power events, [24-11](#)

power supply  
description, [1-6](#)  
installing, [6-4](#)  
LEDs, [2-8](#), [6-2](#)  
removing, [6-2](#)  
servicing, [6-1](#)

power unit components, [24-6](#)

power-on self-test (POST) code checkpoint tests,  
[2-6](#)

powering off the system, [3-4](#)

processor components, [24-6](#)

processors  
 description, [1-6](#)  
 installing, [12-8](#)  
 maximum DIMMs supported, [7-3](#)  
 physical layout, [7-2](#)  
 removing, [12-2](#)  
 replacing, [12-1](#)

PSU, [6-1](#)

## R

---

removing components  
 battery, [11-1](#)  
 DIMMs, [7-9](#)  
 disk backplane, [13-1](#), [13-3](#)  
 disk backplane cables, [17-1](#)  
 fan modules, [5-1](#)  
 FIM, [14-1](#)  
 FIM cable, [17-1](#)  
 M.2 flash SSD, [10-4](#)  
 M.2 mezzanine, [10-1](#)  
 motherboard assembly, [19-2](#)  
 NVMe cables, [16-1](#)  
 OCP NIC, [18-1](#)  
 power cable, [17-1](#)  
 power supply, [6-2](#)  
 processors, [12-2](#)  
 server from rack, [3-12](#)  
 storage drives, [4-3](#)  
 temperature sensor, [15-1](#)  
 temperature sensor cable, [17-1](#)

returning server to operation, [20-1](#)

## S

---

safety  
 ESD precautions, [3-2](#)  
 precautions, [3-1](#)  
 symbols, [3-1](#)

screens, BIOS Setup Utility, [22-1](#), [22-2](#)

Security screen, [23-12](#)

serial management (SER MGT) port  
 configuring serial port sharing, [2-18](#)  
 pinouts, [21-2](#)  
 RJ-45 to DB-9 crossover pinouts, [21-2](#)

serial number, locating, [2-22](#)

serial port sharing  
 configuring, [2-18](#)

server  
 diagnosing, [2-4](#)  
 installing into rack, [20-3](#)  
 removing from rack, [3-12](#)  
 troubleshooting, [2-1](#)

Server hardware faults  
 managing, [2-14](#)

server top cover  
 installing, [20-2](#)  
 removing, [3-13](#)

server troubleshooting, information when  
 contacting support, [2-22](#)

service, [20-1](#)  
 Auto Service Request, [2-23](#)  
 preparing server, [3-4](#)

service processor  
 resetting using pinhole switch, [2-21](#)

shortcut key sequences in BIOS Setup Utility,  
[22-2](#)

shutting down the system  
 gracefully, [3-4](#)  
 gracefully using Oracle ILOM CLI, [3-5](#)  
 gracefully using Oracle ILOM web interface,  
[3-6](#)  
 gracefully using the On/Standby button, [3-7](#)  
 immediately, [3-4](#)  
 immediately using Oracle ILOM CLI, [3-8](#)  
 immediately using Oracle ILOM web  
 interface, [3-9](#)  
 immediately using the On/Standby button,  
[3-7](#), [3-9](#)  
 immediately using the Oracle ILOM CLI, [3-8](#)

Simple Network Management Protocol (SNMP)  
 Traps  
 entity presence events, [24-18](#)  
 environmental events, [24-10](#)  
 fan events, [24-16](#)  
 hard disk drive events, [24-11](#)  
 memory events, [24-17](#)  
 power events, [24-11](#)

standby power, [3-7](#), [3-9](#)

storage drives  
 description, [1-6](#)  
 hot-plugging, [4-1](#)  
 identification, [4-3](#), [4-6](#)  
 installing, [4-4](#), [4-7](#), [4-10](#)  
 latch release button, [4-6](#), [4-9](#)  
 LEDs, [2-7](#)  
 removing, [4-3](#)  
 storage drives  
 identification, [4-9](#)

support for product, [2-22](#)

system chassis components, [24-2](#)

system components and nomenclature, [24-1](#)

system firmware components, [24-8](#)

system motherboard components, [24-7](#)

System OK indicator, [2-6](#)

## T

---

technical support, [2-22](#)

temperature sensor  
installing, [15-4](#)  
removing, [15-1](#)  
replacing, [15-1](#)

temperature sensor cable  
installing, [17-4](#)  
removing, [17-1](#)  
servicing, [17-1](#)

tools required, [3-4](#)

troubleshooting  
information when contacting support, [2-22](#)  
overview, [2-14](#)  
server, [2-1](#)  
using diagnostic tools, [2-14](#)  
using LED status indicators, [2-4](#)  
using Oracle ILOM, [2-1](#)

Trusted Execution Technology (TXT)  
description, [22-5](#)

Trusted Execution Technology (TXT) (*continued*)  
enabling and disabling, [22-10](#)

Trusted Platform Module (TPM)  
enabling and disabling, [22-7](#)

## U

---

UEFI driver  
enabling and disabling, [22-8](#)

UEFI Secure Boot  
description, [22-5](#)  
enabling and disabling, [22-9](#)

USB port  
pinout, [21-3](#)

## W

---

weight of server, [3-12](#)